

DIRECTIONS FOR USE

Trigenflex R96

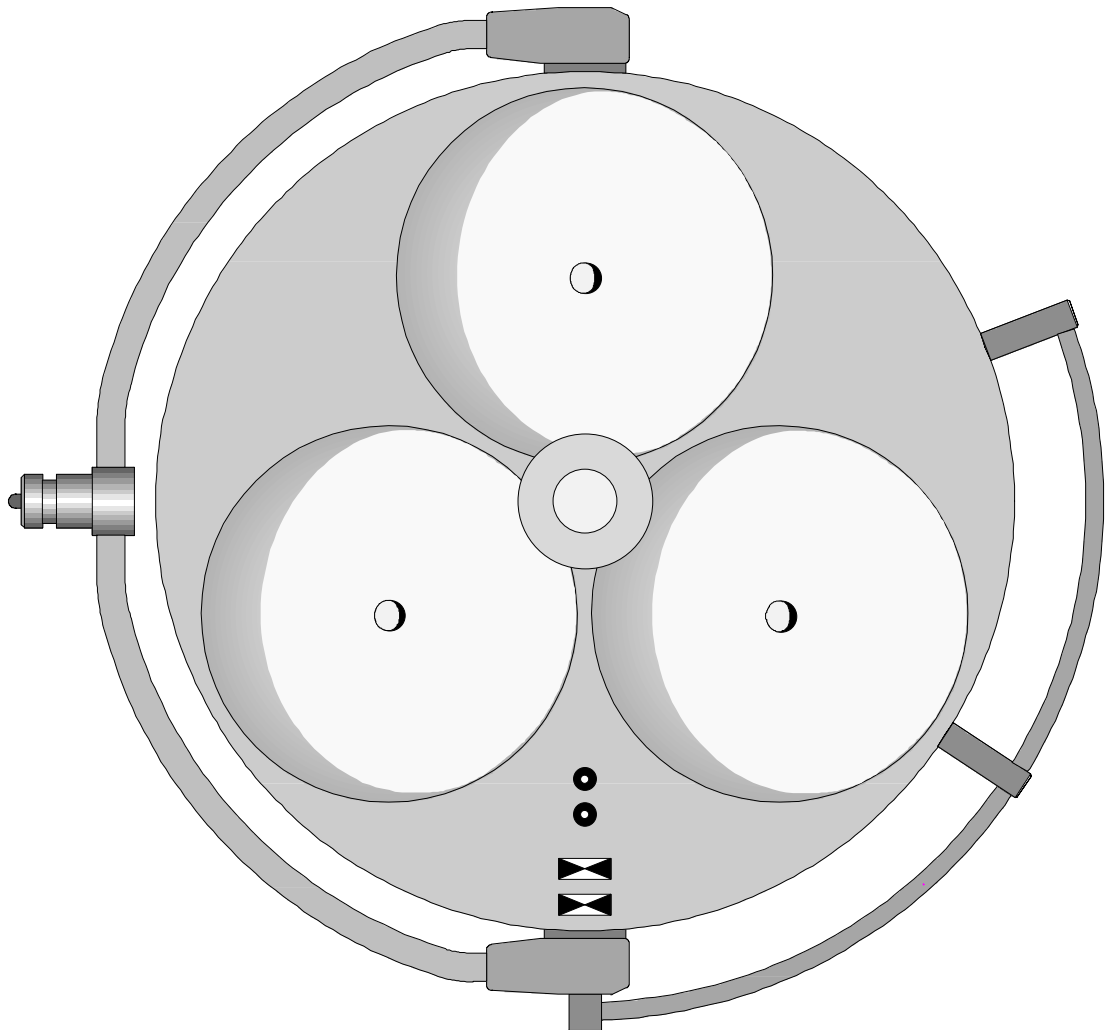

Stand-Lamp _____	Order. No. 3502 3012 00
Wall-Lamp _____	Order. No. 3502 3021 00
Single-Ceiling-Lamp _____	Order. No. 3502 3031 25
	Order. No. 3502 3031 30

Ceiling-Lamps - Combinations

Dr. Mach GmbH u. Co., Flossmannstrasse 28, D-85560 Ebersberg
Tel.: +49 (0)8092 2093 0, Fax +49 (0)8092 2093 50
Internet: www.dr-mach.com, E-mail: info@dr-mach.de

List of contents

1. Safety instructions	Page 3
2. Operating the lamp Trigenflex R96.....	Page 4
2.1 Checking the lamp Trigenflex R96 with light intensity control.....	Page 4
2.2 ON/OFF switch, light intensity adjustment.....	Page 6
2.3 Positioning.....	Page 7
2.4 Light field adjustment (merging of lightfields)	Page 7
3. Cleaning	Page 8
3.1 Sterilizable handle	Page 8
3.2 Lamp head, splinter protection disk.....	Page 8
4. Maintenance.....	Page 9
4.1 Adjustments at the ceiling/ wall attachment.....	Page 9
4.2 Adjustments at the stand model	Page 10
4.3 Adjustments at the lamp head.....	Page 10
4.4 Changing of spare parts	Page 11
4.4.1 Changing the halogen bulbs	Page 11
4.4.2 Changing the fuses	Page 12
4.4.3 Changing the filter disk.....	Page 13
4.4.4 Changing the splinter protection disk	Page 13
5. Data.....	Page 14
5.1 Technical data	Page 14
5.2 Wiring	Page 15
5.3 Environmental conditions	Page 16
6. Marking.....	Page 16
6.1 Specification of bulb	Page 16
6.2 Specification of fuse	Page 17
6.3 CE-mark	Page 17
7. Disposal.....	Page 17
8. Spare parts	Page 18
8.1 Design with power supply 230V/120V	Page 18
8.2 Design with power supply 24V	Page 19
8.3 Swivel arm - stand model	Page 19
8.4 Spare parts list	Page 20

Dear customer!

Congratulations! You have just bought Dr. Mach's newly developed light system R96. The outstanding feature of this light system is its general colour rendition factor $R_a = 96.5$ which had hitherto been unattainable for examination and surgery purposes. This means that the colours are rendered **naturally** and in **full contrast**, with a **pleasant** light around the operating site.

In particular, the differing red shades in the operating field can be recognised with accuracy. For the doctor, this means considerably improved **recognition of detail features in the operating site**.

The light system R 96 uses newly computer optimised cold light filter which **minimise unwanted heat congestion in the head and reduce the radiation of heat onto the illuminated operating site**.

With this product, you have acquired many of the latest developments in lighting technology and mechanics in combination with more than 40 years of experience in manufacturing lights for operating theatres and general medical use.

Please **read the safety instructions and product description carefully** before working with these lights for the first time.

Please follow the separate mounting instructions for ceiling- and wall-mounted lamps, and for fitting the stand foot and pipe.

1. Safety instructions

Please pay attention to the directions for use when handling the lamp.

Attention:

This device is not suitable for use in hazardous locations. The lamp is classified as a Group 1 device according to the Regulations for EEMP.

Repairs to the lamp and special installation work on the reflector or plug-in socket should only be carried out by ourselves or a company expressly authorised by ourselves.

The manufacturer is only responsible for the safety of the lamp if repairs and alterations have been carried out by themselves or a company who can guarantee that the safety regulations have been observed.

The manufacturer is not liable for personal or material damages if the lamp is misappropriately or incorrectly operated or misused.

Make sure that the light is in perfect working order before use.

2. Operating the lamp Trigenflex R96

The dielectric filter disk between reflector and splinter protection disk prevents a damaging heating of the illuminated area.

The lamp may not be used without the dielectric filter.

2.1 Checking the lamp Trigenflex R96 with light intensity control

- **Voltage measurement and setting**

Before using the OT-lamps, a voltage measurement and, if necessary, a voltage setting has to be done. Only in this way a perfect functioning can be ensured. If the location of the lamp is changed, the voltage measurement and setting must be repeated.

- ◆ **Voltage measurement at the halogen bulbs**

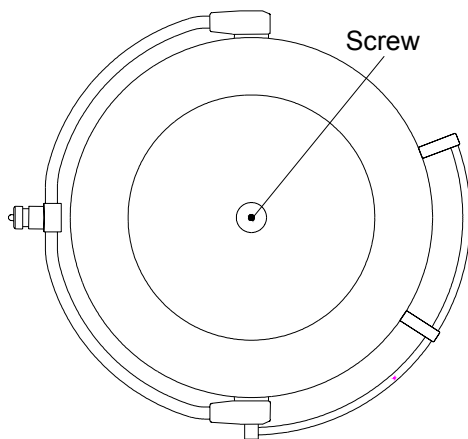

To measure the voltage proceed as follows:
Mount the lamp to the ceiling or wall attachment.
Switch on the lamp.
In order to make the measurement remove the **cover**. Remove the screw in the middle of the cover and take off the cover.

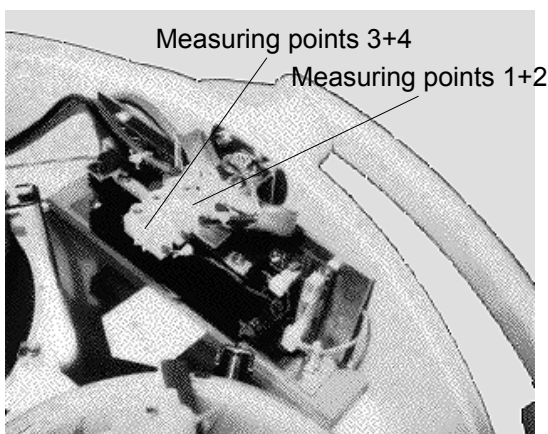

The measuring points for checking the voltage are in the same position on all Trigenflex-lamps. The measuring points are shown in the figure.

At measuring points 1 + 2 measure the voltage applied at the halogen bulbs. **The lamp is set to the maximum light intensity.**

The AC or DC voltage depends on the external power supply.
Rated voltage 22,8-23,8V.

- ◆ **Voltage setting at the halogen bulbs**

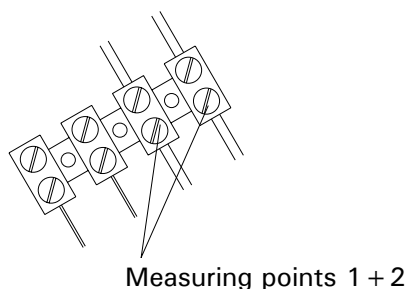

If the voltage measured is too high or too low, the value must be adjusted at the power supply. The setting at the transformer is made by reconnecting the wires on the secondary side.

◆ Voltage measurement at the control board

Please check, whether the power supply is supplying AC or DC.

Voltage measurement at DC

Pay attention to the polarisation during the installation.

If the light intensity control does not function as desired, the PLUS- and MINUS-pole at the power supply have to be changed.

Voltage measurement at AC

For installation at AC proceed as described below:

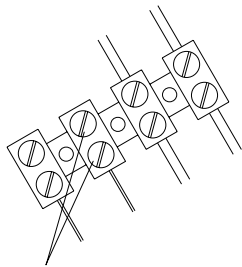

Measuring points 3 + 4

• Preparation

The lamp is already switched on. Set the lamp to the **lowest light intensity**.

• Measurement

Measure the voltage at measuring points 3 + 4. The voltage must be less than 40V DC.

If this value is exceeded, reset it as described below:

◆ Voltage setting at the control board

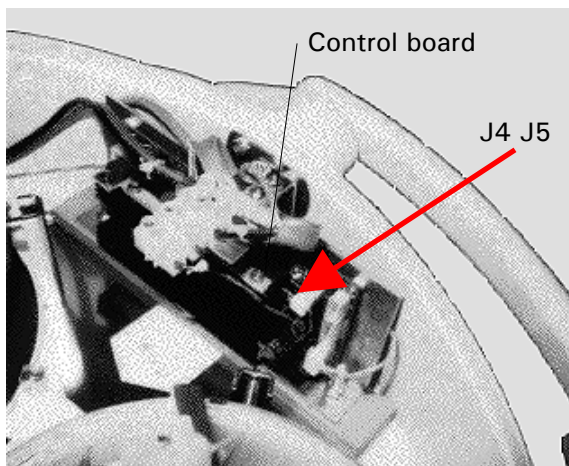

Switch the lamp off.

The position of the control board is shown in the figure.

Adjust the standard setting by changing the jumpers (see arrow).

Three settings enable you to ideally set your lamp system (J4 and J5).

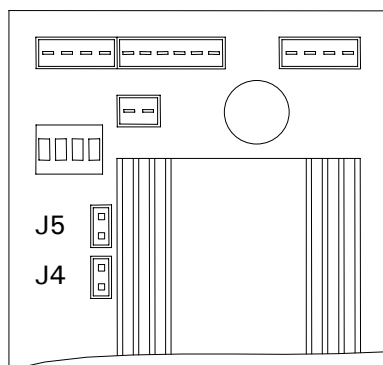
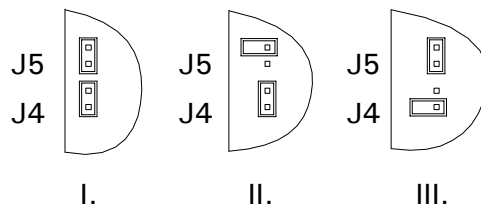

Take off one jumper and put it into position as shown figure II. or III.

Switch on the lamp. Set the lamp to the **lowest light intensity**.

Repeat the voltage measurement at measuring points 3 + 4.

If the voltage is less than 40V DC, keep the chosen setting.

If you measure a voltage in excess of 40V DC, switch off the lamp.
Return the first jumper to the initial position.
Take off the second jumper and place it back on one of the two pins.

Switch on the lamp again. Finally repeat the voltage measurement. The voltage is now adjusted.
Close the lamp by replacing the cover.

2.2 ON/OFF switch, light intensity adjustment

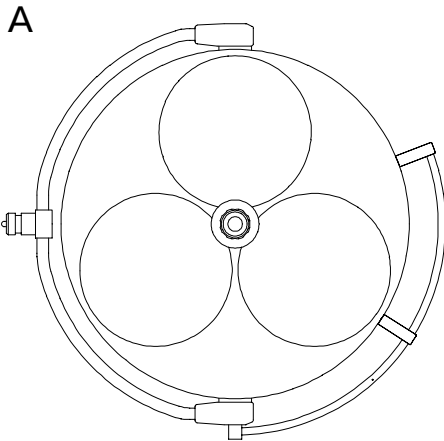

◆ Design for power supply 24V (Figure A) Ceiling/ wall model

There are no ON/OFF switches on the lamp.
The customer must provide a two-pole ON/OFF switch
(see also point 5 of the mounting instructions).

Remark: In case of Trigenflex R96 lights for power supply 24V there is no switch for two-step light intensity adjustment.

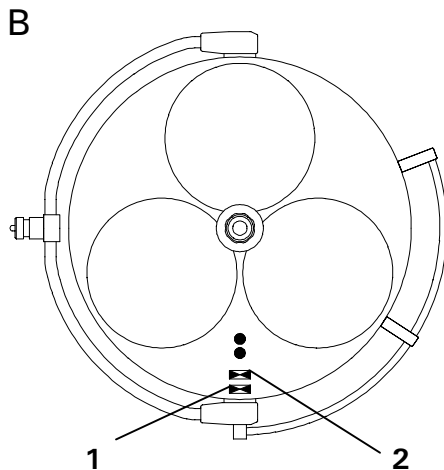

◆ Toroid transformer design for power supply 230V/120V AC (Figure B) Ceiling/ wall model

The rocker switch 1 switches the lamp ON and OFF.
The rocker switch 2 adjusts the light intensity from
bright to dark.

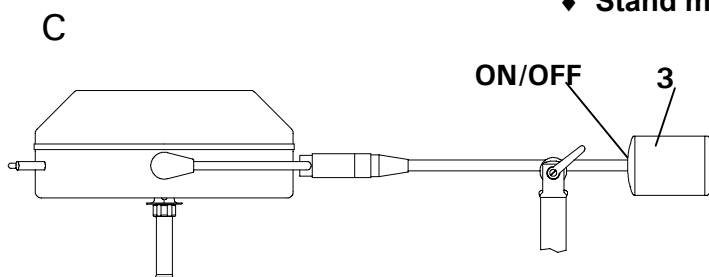

◆ Stand model (Figure C)

The ON/OFF switch is in the counter
balance 3.
There are no ON/OFF switches on the
lamp.

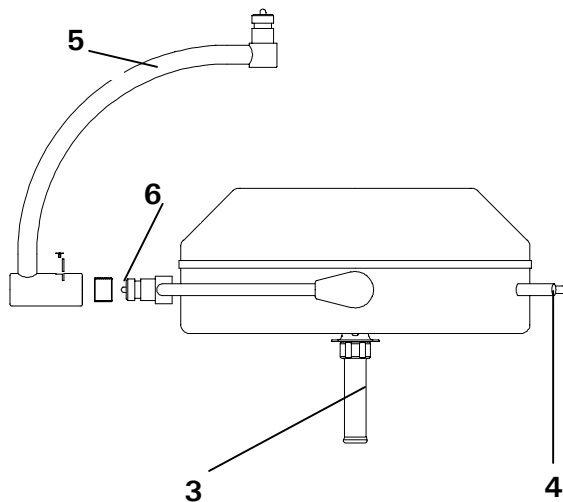

2.3 Positioning

◆ Ceiling/ wall model

For positioning use sterilizable handle **3**.
Handle rail **4** is used for adjusting the lights from the outside.

The cardan bow **5** is used for convenient, fully cardanic adjustment of the lamp.

The cardan bow is delivered separately.

The coupling for the bow of the lamp body is fitted with a needle bearing. The inner ring **6** of this needle bearing has already been pushed onto the axis of the lamp body bow.

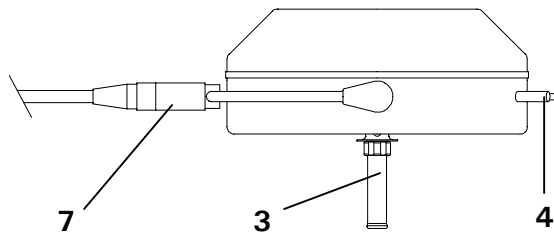

◆ Stand model

For positioning use sterilizable handle **3**.
Handle rail **4** is used for adjusting the lights from the outside.

For free-standing models, the bow of the lamp body is directly coupled to the bracket **7**. Neither part **5** or **6** are used in this case.

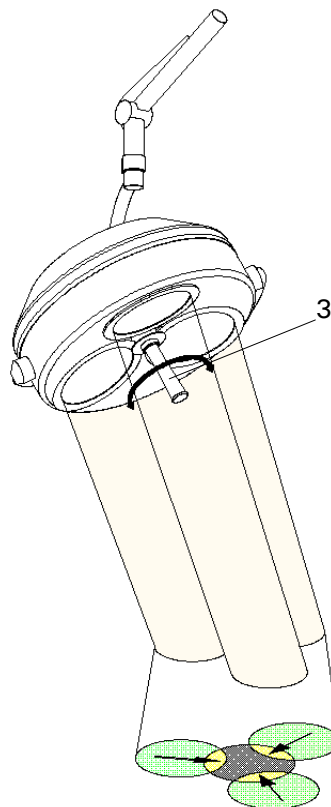

2.4 Light field adjustment (merging of lightfields)

The lights Trigenflex R96 are equipped with the function of lightfield-realignment.
That means, you can merge the separated lightfields to one spot as shown in the figure.

To activate the merging of lightfields turn the handle **3**.

3. Cleaning

3.1 Sterilisable handle

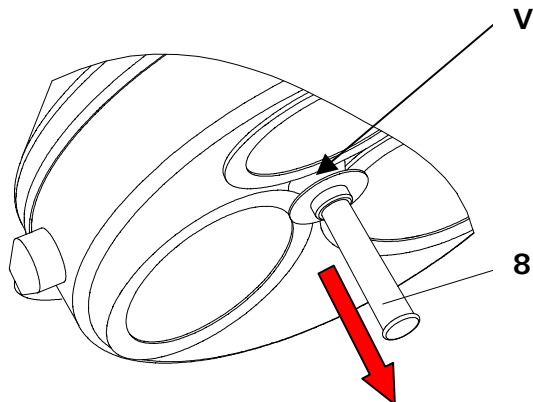

At delivery the lamp is equipped with the **handle sleeve 1**. The handle sleeve is removable and sterilisable. Before using the first time and before every use the handle sleeve must be cleaned, disinfected and sterilised.

The handle sleeve must be removed for sterilisation:

- To remove press the **lock V** and pull off the sterilisable handle sleeve **1** while keeping the lock pressed.
- To attach, push on and slightly twist the handle until the **lock V** engages securely.

Handles often become unsterile during an OP; therefore always keep additional handles available for exchange.

Cleaning / disinfection and sterilisation

Basics

Efficient cleaning / disinfection is an essential requirement for effective sterilisation of the handle. Within the scope of responsibility for the sterility of the products it should be noted that only sufficiently validated equipment and product specific processes are used for cleaning / disinfection and that the validated parameters are complied with in every cycle. In addition, the hospital / clinic hygiene regulations must be observed.

Cleaning / disinfection

Cleaning and disinfection must be carried out immediately after use. A mechanised process (disinfector) should be used for cleaning / disinfection. The efficiency of the process used must be recognised and validated in principle (e.g. listed under disinfectants and disinfection procedures tested and recognised by Robert-Koch-Institute / DGHM). When using other procedures (e.g. a manual procedure), proof and process efficiency in principle must be provided within the scope of validation. Proof in principle of the suitability of the handles for efficient cleaning / disinfection was provided using a cyclic cleaning system (Netsch-Bellmed T-600-IUDT/AN, programme 2 for small parts; code B).

It is not allowed to use agents / disinfectants, which contain the following substances, as these may cause changes in the material:

- High-concentration organic and inorganic acids
- Chlorinated hydrocarbons
- 2-ethoxyethanol

When cleaning / disinfecting, the following procedures must be followed:

	Process	Time (sec.)
Zone 1	Pre-rinse, external, cold, 10 – 15°C Washing, acidic, external 35°C Draining time Re-rinse, external approx. 80°C Draining time Re-rinse, external approx. 80°C Draining time	45 120 10 *10 *15 *15 15
Zone 2	Washing, alkaline, external, 93°C Draining time Re-rinse, external, acidic, 90°C Draining time Re-rinse, external 90°C Draining time	135 10 10 15 15 15
Zone 3	Drying, external 100 – 120°C	200
Zone 4	Drying, external 100 – 120°C	200
	Door open / close & transport (sluice discharge)	60
	Cycle time overall ca.	290 ≈ 5 minutes

* When occupying the disinfection zone (washing zone 2), the re-rinse and draining times will depend on the respective objects being washed therein!

Sterilisation

Only previously cleaned and disinfected handles may be sterilised.

The handles are placed in a suitable sterilisation pack (one-way sterilisation pack, e.g. foil / paper sterilisation bags, single or double pack) in accordance with DIN EN 868 / ISO 11607 for steam sterilisation and then sterilised.

Use only the sterilisation procedure listed below for sterilisation. Other sterilisation procedures (e.g. ethylene oxide, formaldehyde and low-temperature plasma sterilisation) are not permissible.

Steam sterilisation procedure

Validated in accordance with DIN EN 554/ISO 11134

Maximum sterilisation temperature 134°C

Proof in principle of the handles' suitability for effective sterilisation was provided using a fractional vacuum process (Euroselectomat 666 by MMM Münchner Medizin Mechanik GmbH, sterilising temperature 134°C, holding time 7 min.)

Inspection / durability

The handles should be inspected for damage and changed before re-use, if required.

The handles may be cleaned / disinfected, sterilised and re-used for a maximum of 1000 times. If the handles are re-used more than 1000 times, then this will be the responsibility of the hospital / clinic.

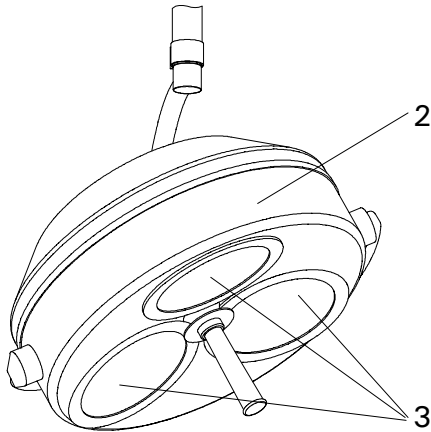

3.2 Lamp head, splinter protection disk

The lamp head **2** has a high-quality surface, which can be cleaned with conventional cleaning agents.

The splinter protection disks **3** are made of a high-quality plastic. Pay attention to the following during cleaning:

- Wipe the splinter protection disks **3** always with a wet cloth. (Do not wipe dry!)
- Only use disinfectant with less than 20% alcohol.

Wipe the splinter protection disks **3** after cleaning with an antistatic, non-fluffy cloth.



Alc. ≤ 20 %

4. Maintenance

The light has been designed and built so that regular maintenance intervals are not necessary. In order to keep the system easy running throughout its life span we recommend that the hinges be greased once a year with an acid-free grease.

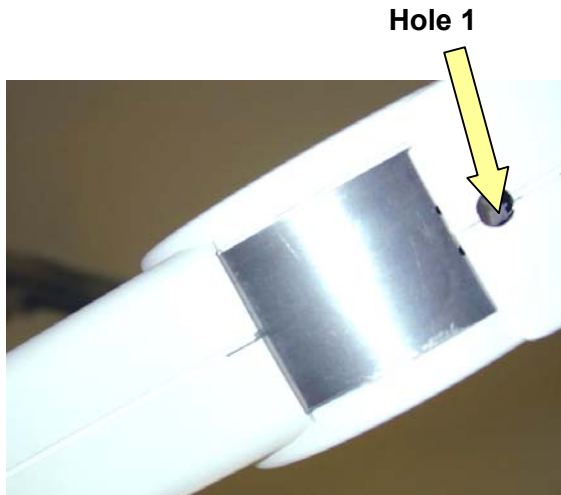

4.1 Adjustments at the ceiling / wall attachment

◆ Adjusting the spring arm

Note:

Maximum additional load at spring arms: Spring arms are equipped with different springs to compensate the lamp / device weight.

To adjust the spring force make sure that the spring arm with the lamp / device can come to rest in any desired position.

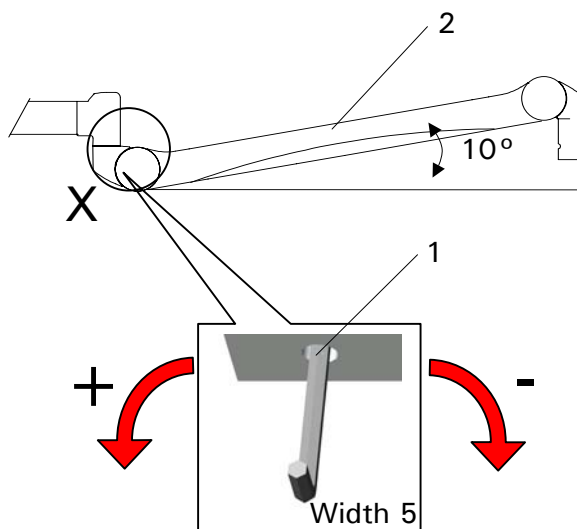

- A hole 1 is located at the position marked by detail X.
- Position the spring arm 2 with the lamp / device approximately 10° above horizontal.
- Insert Allan key (width 5, included in the scope of supply) into the hole 1.

If the spring arm drops, the spring force is too low:

- Rotate the adjustment screw to the **left** (counter clockwise) in the + direction.

If the spring arm rises, the spring force is too high:

- Rotate the adjustment screw to the **right** (clockwise) in the - direction.

If the spring arm with the lamp / device cannot come to rest in any desired position after the spring force has been adjusted, the springs must be replaced by a service technician.

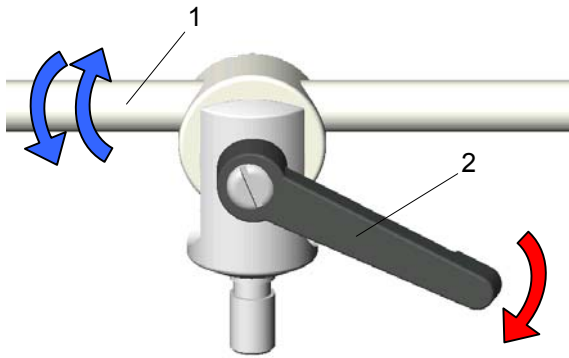

4.2 Adjustments at the standmodel

◆ Swivel arm

You can fasten the move of the swivel arm 1 by adjusting lever 2.

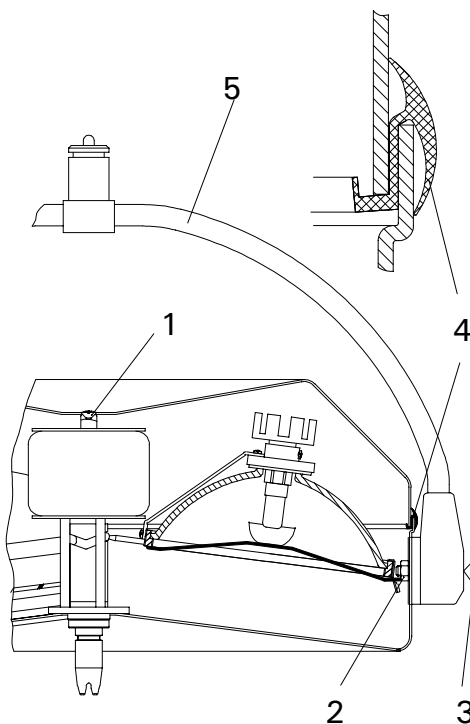

4.3 Adjustments at the lamp head

◆ Adjusting the lamp bow

In case you notice that the light no longer remains at its set position, it may be necessary to adjust the lamp bow 5.

For adjusting proceed as follows:

- Turn off the light.
- Unscrew the raised countersunk screw 1 using a cross screwdriver.
- Remove the upper part of the lamp housing.
- Screw the nuts 2 on both sides a little tighter using an open-ended or ring wrench SW 14, or loosen these nuts while at the same time holding the screw slot 3 in each case with a screw driver.
- Once the adjustment has been made, place seal 4 correctly on the housing lower part and position the upper part of the lamp housing slightly diagonally from one side so that the seal lies cleanly around the circumference.
- Using a round object (drawing pin or small screwdriver) lift the seal and lower the lamp housing upper part until it sits evenly around the whole circumference.
- Tighten using the raised countersunk screw 1.

4.4 Changing of spare parts

4.4.1 Changing the halogen bulbs

Dr. Mach uses special halogen bulbs as illuminants.

Only original Dr. Mach replacement bulbs may be used.

The use of other bulbs can lead to a considerable reduction of the light power and increase in the thermal load.

To change the halogen bulbs proceed as follows:

- Turn off the light.
- Rotate the three quick-release fasteners **1** half a turn anticlockwise so that the corresponding disk bearer can be removed from the bottom part of the lamp housing.
- Press outward security clip **2** and turn shadeholder **3** down.
- Carefully remove the halogen bulb (22,8-24V/50W) from its socket, change and replace.
- Replace shadeholder and the disk bearer onto the bottom part of the lamp housing and rotate the quick-release fasteners **1** clockwise.

Do not touch the halogen bulb with naked hands. Remove stains with a clean cloth and alcohol since otherwise these can burn into the glass and lead to early failures.

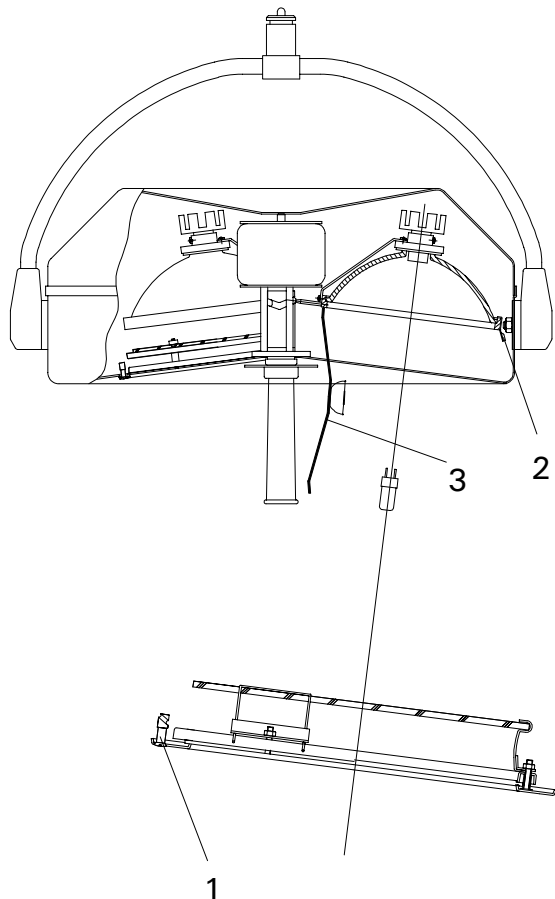

Attention

The halogen bulbs have a service life of approx. 1200 hours without any deterioration in their luminosity.

If after approx. 1/2 year of average use of 8 hours daily one of the halogen light bulbs should fail, we recommend that the whole set should be replaced.

4.4.2 Changing the fuses

◆ Ceiling/ wall/ stand model Power supply with 24V AC/DC

In the case of designs for power supply with 24V AC/DC the necessary fuses are provided by the customer.

◆ Ceiling/ wall model Power supply with 230V/120V AC - built in toroid transformer

The fuses in the lamp housing (in the toroid transformer design) prevent the transformer burning through in the event of a short circuit.

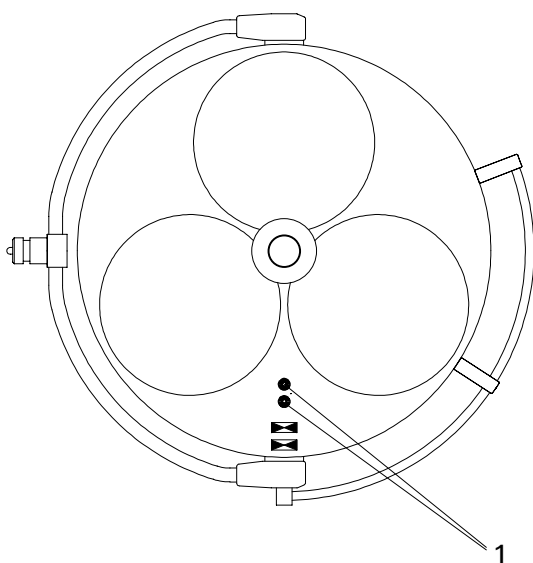

Visible type 5x20/2,00A/250V/T for 230 V
Visible type 5x20/4,00A/250V/T for 120 V

If the bulb is no longer on, check the bulb first, then the fuses.

To change the fuses proceed as follows:

- Turn off the light.
- Turn the black fuse holder 1 1/4 of a rotation anticlockwise with a screwdriver.
- Change the fuses.
- Insert the fuse holder under slight pressure and rotate in a clockwise direction (bayonet catch).

Pay attention to the instructions from the local installer.

◆ Stand model Power supply with 230V AC

The fuses are in the counter balance 2 as shown in the figure.

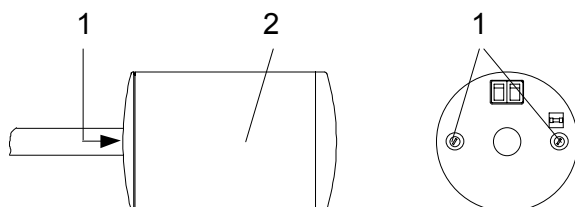

Visible type 5x20/2,00A/250V/T for 230 V

To change the fuses proceed as follows:

- Turn off the light.
- Turn the black fuse holder 1 1/4 of a rotation anticlockwise with a screwdriver.
- Change the fuses.
- Insert the fuse holder under slight pressure and rotate in a clockwise direction (bayonet catch).

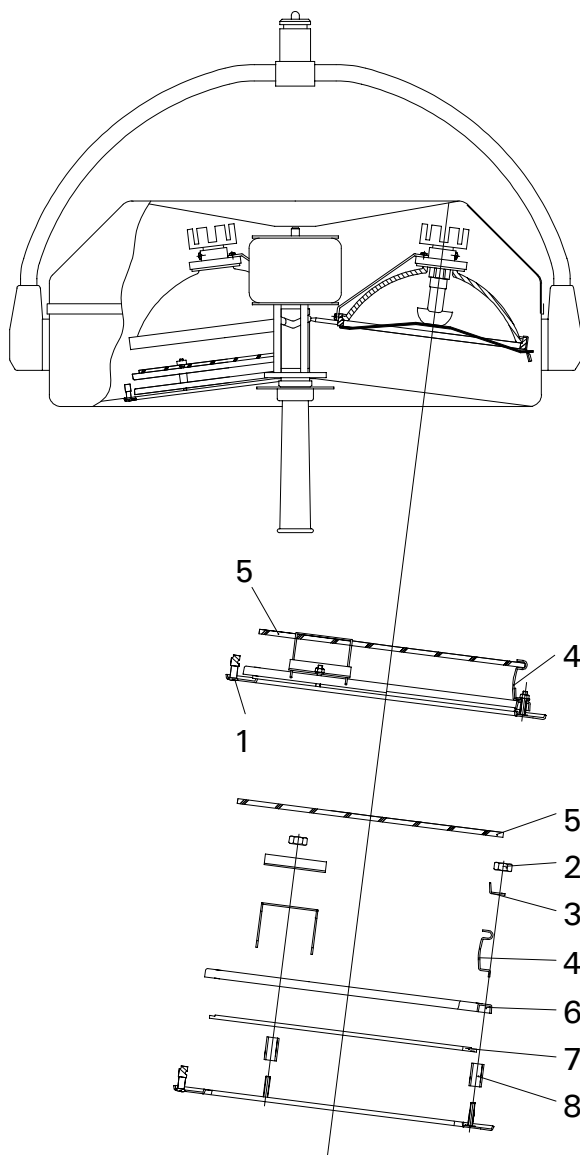

4.4.3 Changing the filter disk

The dielectric filter disk between reflector and splinter protection disk prevents a damaging heating of the illuminated area.

The lamp may not be used without this filter

To change the filter disk proceed as follows:

- Turn off the lamp.
- Rotate the three quick-release fasteners **1** half a turn anticlockwise so that the corresponding disk bearer can be removed from the bottom part of the lamp housing.
- Slightly loosen nuts **2**, carefully bend the retaining springs **4** apart and replace the filter disk **5**.

Only use filter disks which have been cleaned accordingly.

4.4.4 Changing the splinter protection disk

In case the light quality is getting worse because of a dull splinter protection disk, it may be necessary to change the disk.

To change the splinter protection disk proceed as follows:

- Turn off the lamp.
- Rotate the three quick-release fasteners **1** half a turn anticlockwise so that the corresponding disk bearer can be removed from the bottom part of the lamp housing.
- Remove filter disk **5** as described under 4.4.3.
- Loosen the three M3 nuts **2**, remove retaining spring **4** and retaining ring **6**.
- Replace splinter protection disk **7** and lay stay tube **8**, retaining ring, retaining spring and clamp in the correct order on the disk bearer according to the illustration.
- Place nuts **2** onto the threaded bolts according to the illustration and tighten.
- Carefully bend the retaining springs **4** apart and replace filter disk.



Only use filter disks which have been cleaned accordingly.

- Replace disk bearer and fasten by turning the three quick-release fasteners **1**.



5. Data

5.1 Technical data



Design with 24 Volt

~	Wechselstrom		alternating current
	Nennspannung	22,8V AC/DC	rated voltage
	Nennstrom	6.57A	rated current
Hz	Hertz-Frequenz	50/60Hz	frequency Hertz
	Sicherung		fuse
	Schutzgrad	Typ"B"	class of protection

Design with 230 Volt

~	Wechselstrom		alternating current
Pr	Primaerseitig	230V / 0,83A	primary side
Sek	Sekundaerseitig	22,8V / 6,57A	secondary side
Hz	Hertz-Frequenz	50/60Hz	frequency Hertz
	Sicherung		fuse
	Schutzgrad	Typ"B"	class of protection

Design with 120 Volt

~	Wechselstrom		alternating current
Pr	Primaerseitig	120V / 1,63A	primary side
Sek	Sekundaerseitig	22,8V / 6,57A	secondary side
Hz	Hertz-Frequenz	50/60Hz	frequency Hertz
	Sicherung		fuse
	Schutzgrad	Typ"B"	class of protection

5.2 Wiring

Design with 24 Volt

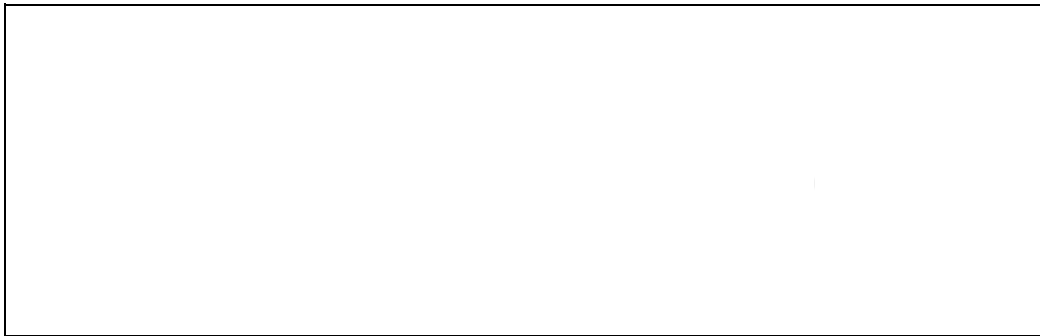

Design with 230 Volt

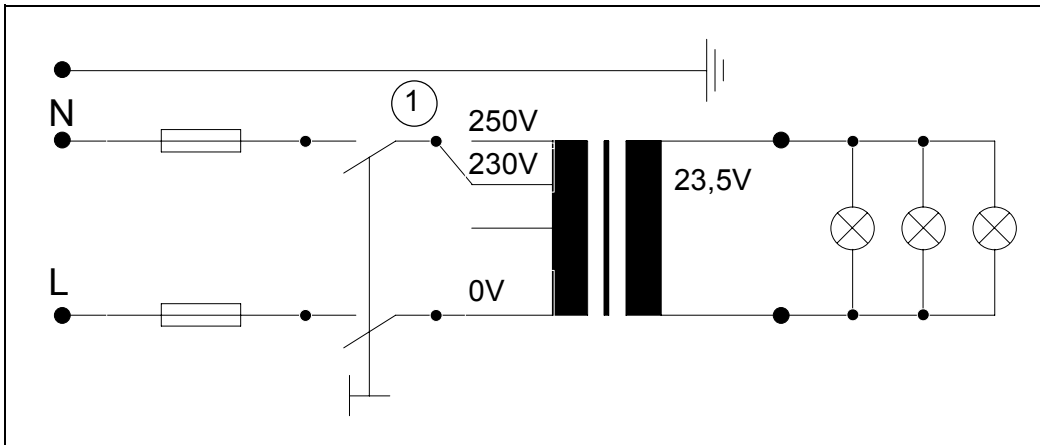

1 - two-step switch, depending on design

Design with 120 Volt

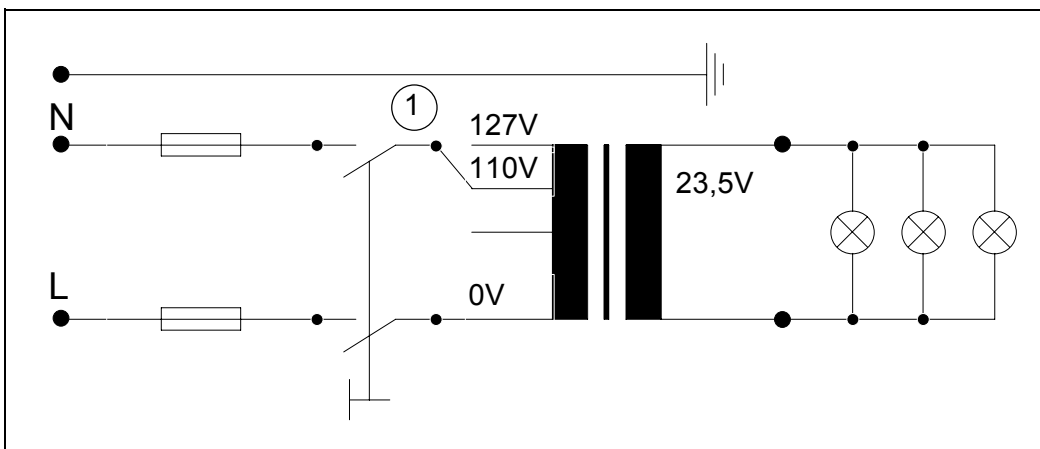

1 - two-step switch, depending on design

5.3 Environmental conditions

Operation

	Min.	Max.
Temperature	+10°C	+40°C
Relative atmospheric humidity	30%	75%
Air pressure	700 hPa	1060 hPa

Transport / Storage

	Min.	Max.
Temperature	-10°C	+50°C
Relative atmospheric humidity	20%	90%
Air pressure	700 hPa	1060 hPa

6. Marking



Protective conductor



Switch "ON/OFF "

6.1 Specification of bulb

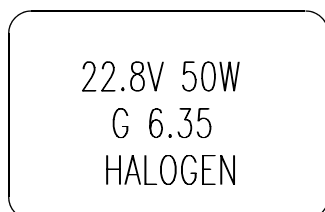

Voltage , power
Socket
Mode of operation

6.2 Specification of fuse

Design with 24 Volt

The lights do not have fuses in the lamp housing.

Design with 230 Volt

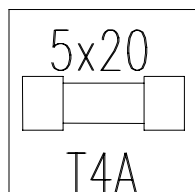

Visible fuse 5x20
Delay action 2,00A

Design with 120 Volt

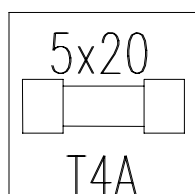

Visible fuse 5x20
Delay action 4,00A

6.3 CE-mark



The products Trigenflex R96 comply to the standards 93/42/EEC for medical products of the European Community's Council.

7. Disposal

The OT- light Trigenflex R96 does not contain any danger goods.
The components of the OT- light should be properly disposed at the end of their shelf life.
Make sure, that the materials are separated accordingly.

For disposal proceed as follows:

- PC-boards should be submitted to an appropriate recycling.
- The rest of the components should be disposed according to the contained materials.

8. Spare parts

8.1 Design with 230/120 Volt - built in transformer (Ceiling/ wall model)

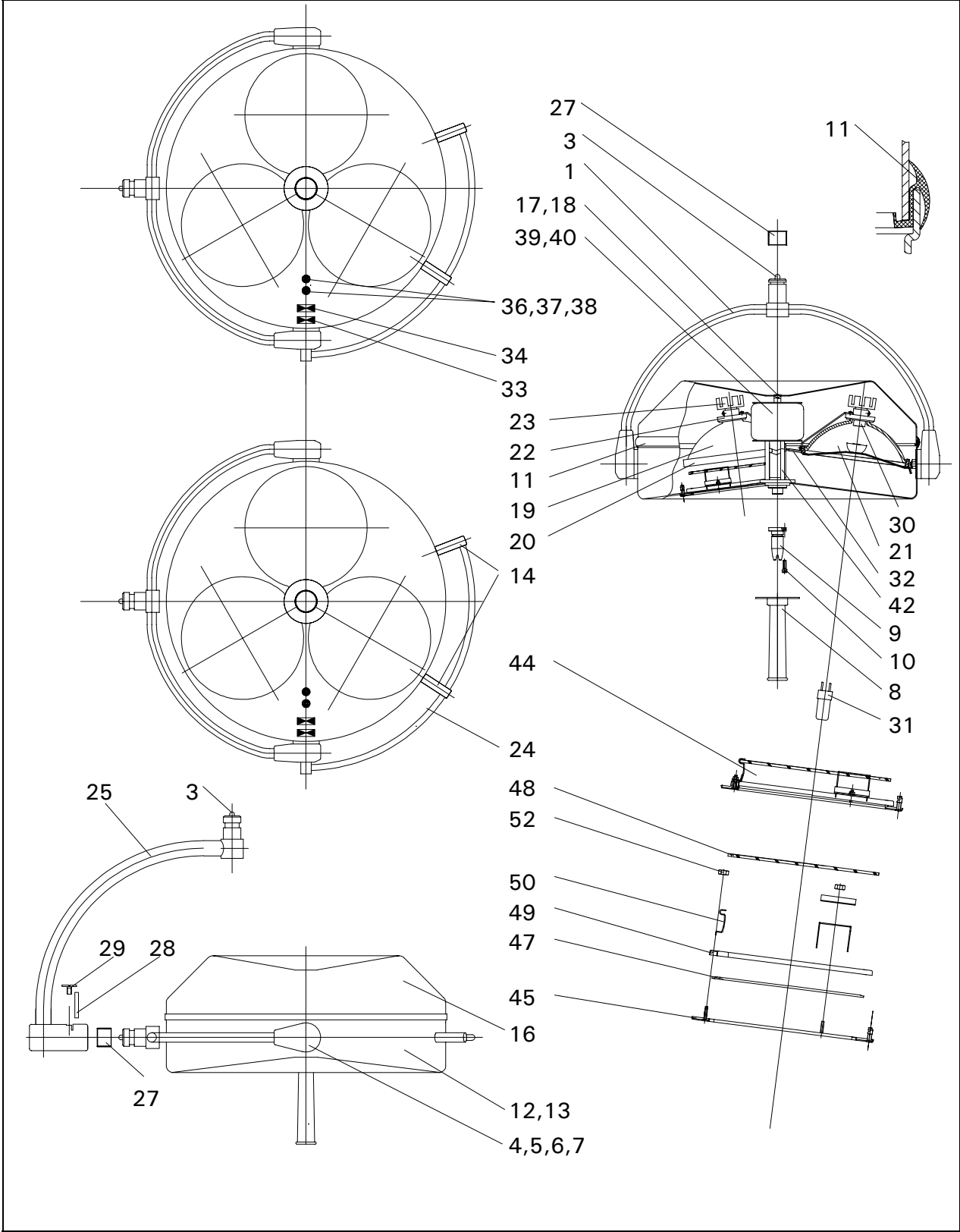

8.2 Design for power supply 24 Volt (Ceiling/ wall/ stand model)

The light does not have a built in transformer, fuses, ON/OFF switch and change-over switch.
For spare parts see point 8.1, excluding the parts mentioned above.

8.3 Swivel arm (stand model)

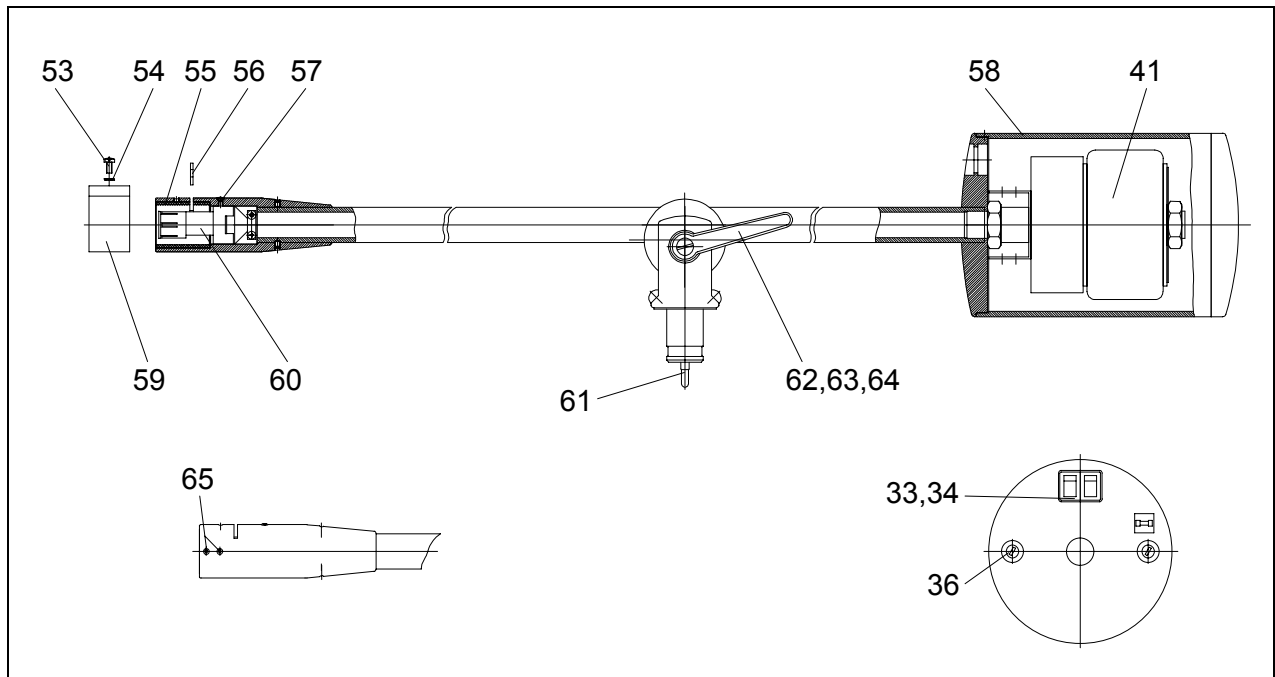

8.3 Spare parts list

Item	Qty.	Name	EDVNO	Remarks
01	1	Lamp bow complete	23100002	alternative
02				
03	2	Sliding contact -pin	67330002	1x in 1 and 25 or 26
04	2	Bolt	22080203	
05	2	Corrugated washer	65542002	
06	2	Pressure washer	07011204	
07	2	Hexagonal nut M10x1 DIN 439	67500001	
08	1	Sterilisable handle sleeve	21150002	
09	1	Handle coupling	23052001	
10				
11	1	Seal	23000201	
12	1	Housing lower part for toroid transformer	23012007	230V/120V
13	1	Housing lower part for ext. transformer	23012008	24V
14	2	Bolt, complete	23082202	
15				
16	1	Housing upper part	23011202	
17	1	Raised countersunk screw M4x12 DIN 966	65112007	
18	1	Washer	22080206	
19	3	Reflector, complete	23060002	
20	3	Reflector support with shade	23061003	
21	3	Glass reflector	10060201	
22	3	Flange	23060208	
23	3	Cooling body	23060214	
24	1	Handle bow, complete	23040001	
25	1	Cardan bow, complete	23110001	
26				
27	1	Inner ring for needle bearing in part 25	23110202	
28	1	Semi-circular spring	23110203	
29	1	Locking screw for semi-circular spring		
30	3	Socket	67320001	
31	3	Halogen bulb 22,8-24V/50W	67100202	
32	3	Tracer pin	23060207	
33	1	Change-over STRONG/WEAK	67340001	230V/120V
34	1	Two-pole illuminated ON/OFF switch	67340002	230V/120V
35				
36	2	Fuse holder	67370001	230V/120V, Stand model
37	2	Visible fuse 5x20 2,00A/250V/t	67370005	230V
38	2	Visible fuse 5x20 4,00A/250V/t	67370007	120V
39	1	Toroid transformer 150VA/prim.230V AC /sec.22/24V AC	23051001	230V RFT BV381187
40	1	Toroid transformer 150VA/prim.120V AC /sec.22/24V AC	23051002	120V
41	1	Toroid transformer 150VA	53238001	Stand model
42	1	Central-axle complete	23050002	
43				

Item	Qty.	Name	EDVNO	Remarks
44	3	Disk bearer complete	23160002	
45	3	Disk bearer ring with quick-release fastener	23161001	
46				
47	3	Splinter protection disk	23200201	
48	3	Dielectric filter disk	23250201	
49	3	Retaining ring	23160205	
50	9	Retaining spring	23160202	
51				
52	9	Nut M3 DIN 934	65332002	
53	1	Raised head screw DIN7985 HM4x10 -4,8Ni	65152010	
54	2	Lock washer A4,3 DIN6797 -Zn	65582004	
55	1	Brake ring	07100202	
56	1	Semi-circular spring	74011001	
57	1	Countersunk screw DIN966 HM3x12 -4,8Zn	65112004	
58	1	Housing	53237210	
59	1	Sliding sleeve for semi-circular spring	53070208	
60	1	Sliding contact -receptacle	67330001	
61	1	Sliding contact -pin	67330002	
62	1	Washer A8,4 DIN125 -Zn	65512008	
63	2	Brake disk	53237212	
64	1	Adjusting lever	74503002	
65	4	Thread pin DIN551 M4x4 14H	65212002	
66	1	Acrylic glass box for transformer 300VA	67610101	Not shown

