

Operating Instructions

Ecoline

Immersion thermostats E 200
Bath/ Circulation thermostats
E 206 T, E 212 T, E 215 T, E 220 T
E 203, E 211, E 219, E 225

From Series Z 01
from software version 3.4
01/02
YAEE0013

LAUDA DR. R. WOBSE
GMBH & CO. KG
P.O. Box 1251
97912 Lauda-Königshofen
Germany
Phone: (+49) (0) 9343/ 503-0
Fax: (+49) (0) 9343/ 503-222
e-mail info@lauda.de
Internet <http://www.lauda.de>

Safety notes



Before operating the equipment please read carefully all the instructions and safety notes.

If you have any questions please phone us!

Follow the instructions on setting up, operation etc. This is the only way to avoid incorrect operation of the equipment and to ensure full warranty protection.

- Transport the equipment with care!
- Equipment and its internal parts can be damaged:
 - by dropping
 - by shock.
- Equipment should only be operated by technically qualified personnel!
- Never operate the equipment without the bath liquid!
- Do not start up the equipment if
 - it is damaged or leaking
 - the supply cable is damaged.
- Switch off the equipment and pull out the mains plug for
 - servicing or repair
 - the supply cable is damaged!
- Drain the bath before moving the equipment!
- Have the equipment serviced or repaired by properly qualified personnel only!

The Operating Instructions include additional safety notes which are identified by a triangle with an exclamation mark. Carefully read the instructions and follow them accurately! Disregarding the instructions may have serious consequences, such as damage to the equipment, damage to property or injury to personnel

We reserve the right to make technical alterations!

1	BRIEF OPERATING INSTRUCTIONS	1
2	CONTROL AND FUNCTIONAL ELEMENTS	3
3	UNIT DESCRIPTION	4
3.1	Unit description	4
3.2	Pumps.....	4
3.3	Temperature indication, control, and safety circuit	5
3.4	Materials	5
3.5	Serial Interfaces RS 232, RS 485	6
3.5.1	RS 232 Interface	6
3.5.2	RS 485 Interface	8
3.5.3	Write commands (data commands to the thermostat).....	10
3.5.4	Read commands (data requested from thermostat).....	11
3.5.5	Error messages	12
3.5.6	Driver software for LABVIEW®	12
4	UNPACKING	13
5	PREPARATIONS	14
5.1	Assembly and setting up.....	14
5.2	Filling and emptying	16
5.3	Bath liquids and hose connections.....	18
5.4	Connection of external circuits	20
5.5	Cooling the thermostats.....	22
6	STARTING UP	23
6.1	Connection to the supply	23
6.2	Switching on	23
6.3	Setpoint selection (level 0)	24
6.4	Menu functions	25
6.4.1	Pump output	25
6.4.2	Setting the setpoint resolution	26
6.4.3	Parameters.....	27
6.4.3.1	Setting the proportional band of the PID-controller	27
6.4.3.2	Setting the reset time of the PID-controller.....	28

6.4.3.3	Selection of the interface	29
6.4.3.4	Setting the Baud rate/ transfer rate (serial interface)	30
6.4.3.5	User calibration.....	31
6.5	Warning and safety functions	33
6.5.1	Overtemperature protection and testing	33
6.5.2	Low-level protection and testing.....	34
6.5.3	Pump motor monitoring	35
6.5.4	Connection floating contact "Combination fault" 31 N	35
6.5.5	Other error messages.....	36
7	SAFETY NOTES	37
7.1	General safety notes.....	37
7.2	Other safety notes	37
8	MAINTENANCE	39
8.1	Cleaning.....	39
8.2	Maintenance and repair	39
8.3	Ordering spares	40
9	TECHNICAL DATA(TO DIN 58966)	41
10	ACCESSORIES	45
11	CIRCUIT DIAGRAM.....	47

Explanation of signs



Danger:

This sign is used where there may be injury to personnel if a recommendation is not followed accurately or is disregarded.



Note

Here special attention is drawn to some aspect. May include reference to danger.



Reference:

Refers to other information in different Sections.

1 Brief operating instructions



This brief instruction shall give you the possibility to operate the unit quickly. For safe operation of the unit it is absolutely necessary to read carefully all the instructions and safety notes!

1. Assemble unit and add items as appropriate (➤ Section 5).
Take care of the hose tubing connections (➤ Section 5.1. and 5.4.).
2. Fill the unit with corresponding liquid. (➤ Section 5.3.).
The units are designed for operation with non-flammable and flammable liquids to EN 61010-2-010. ➔ Take care of the level of the bath liquid! (➤ Section 5.2.)
3. Connect the unit only to a socket with a protective earth (PE) connection.
Compare the information on the rating label with the supply details.

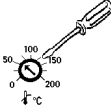
4.  Using a screwdriver, set the overtemperature cut-out point to a value clearly above ambient temperature (➤ Section 6.5.1.).



5. Switch on at the mains switch
6. Setting of the functions

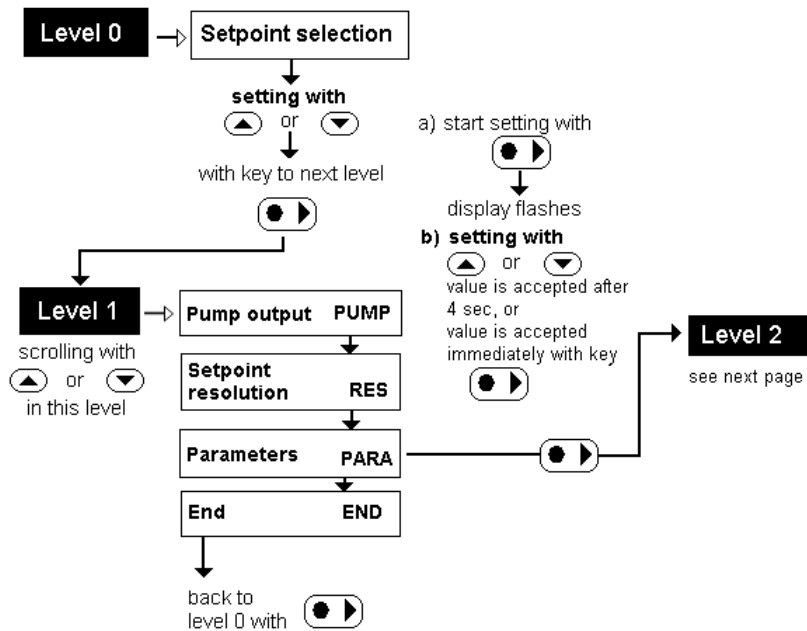

Brief operating instructions

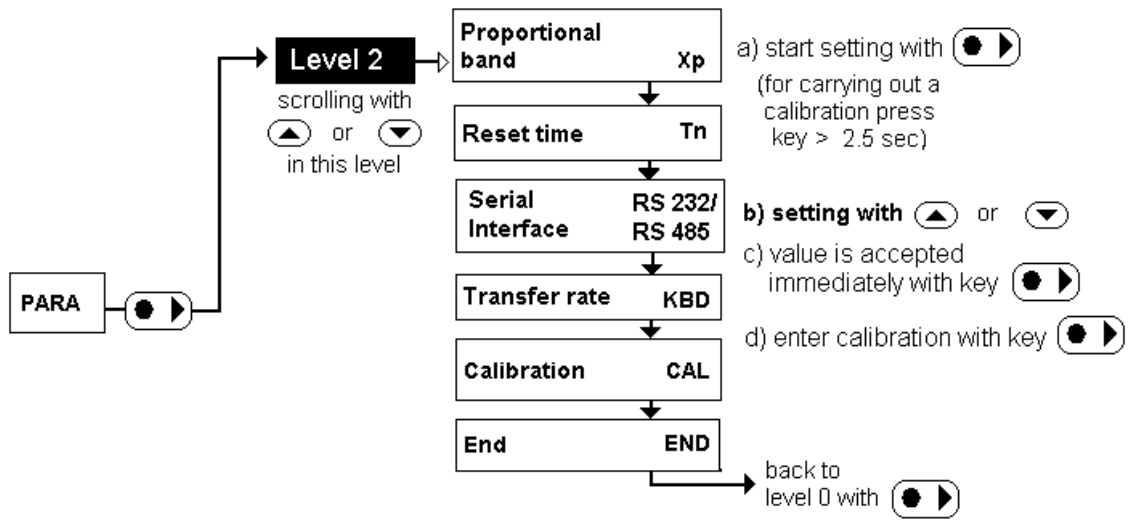

2 Control and functional elements

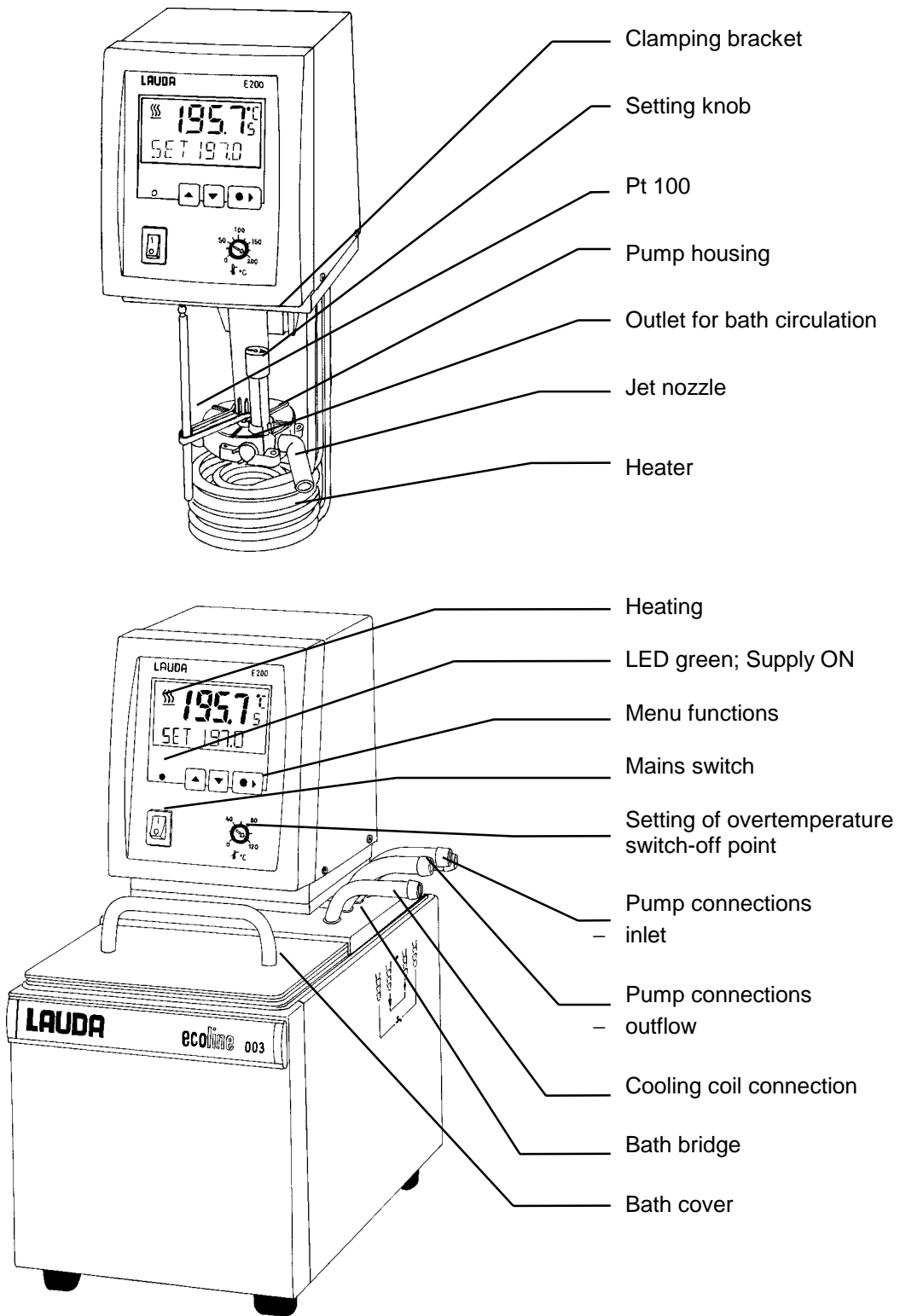

Unit description

3 Unit description

3.1 Unit description

The immersion thermostats E 200 have a device for fixing the immersion thermostat to the bath vessel (clamping bracket). An adapter is supplied for the deep-drawn LAUDA baths 003, 011, 019 and 025.

The type designation of the Ecoline bath/circulation thermostats consists of the control unit E 200 and the type of bath.

Example: Control unit E 200 and bath 003 produces Thermostat Type E 203ö.

The letter T (for "Transparent") refers to the baths made of polycarbonate. Type E 203 are supplied with bath cover. For other baths made of stainless steel bath covers are available as accessory.
(> Section 10. Accessories)

3.2 Pumps

All units are supplied with a pressure pump with vario-drive. The pump has an outlet with a rotatable bend (immersion thermostat) which is connected to the pump nipple for external thermostating circuits (bath/circulation thermostats). An additional outlet provides circulation within the bath. By turning the setting knob you can choose between both outlets or divide the flows.

The pump chamber of immersion thermostats is rotatable in a restricted way to reach an optimal circulation. The pump can be used up to viscosities of 150 mm²/s during heating up. To get an optimum accuracy of control a viscosity of < 30 mm²/s is recommended.

One of five pump output steps can be selected using the operating menu.

On small bath thermostats (e.g. E 203 or E 206 T) and with operation as bath thermostat it is advisable to use output step 1. The advantage is a low heat generation while having a uniform circulation, that means, that the unit can work without cooling down to just above ambient temperature.

When operating as circulation thermostat with an external circuit it is preferable to use a larger flow setting in order to ensure a small temperature difference, especially at higher temperatures and in conjunction with oil as the bath liquid.

The pump outflow connection can be closed off without causing any damage to the pump.

Pump characteristics (> Section 9. Technical data)

3.3 Temperature indication, control and safety circuit

The unit is provided with a 2-line LCD-Display with additional symbols for indicating bath temperature and settings as well as operating states. The setpoint is input and additional adjustments can be made using either two or three keys.

Remote operation is possible via an isolated RS 232 interface

A Pt 100 temperature probe is used for measuring the actual temperature and for control. A second Pt 100 serves as temperature probe for the safety circuit (overtemperature protection) which is independent of the control function

A low-level cut-out switches off the heating on both poles in order to prevent dry operation of the heater. The pump is switched off through the electronics. The setting of the overtemperature cut-out is adjusted with a tool on a potentiometer and is always limited to 5 °C above the operating temperature range. A floating contact "Combination fault" is available (➤ Section 6.5.4.).

All settings and fault messages are stored in the memory on supply failure or when the mains switch is set to OFF

The tubular heater is controlled from a modified PID controller through a triac circuit specially designed to be unaffected by supply variations and interference.

3.4 Materials

All parts which come into contact with the bath liquid are made from high-grade materials appropriate to the operating temperature. These are rust-free stainless steel, the plastics PPS, polycarbonate (bath 006 T, 015 T, 012 T, 020 T) and fluoride rubber.

Unit description

3.5 Serial Interfaces RS 232, RS 485

3.5.1 RS 232 Interface

Computer				Thermostat RS 232 Interface			
Data	9-pin sub-D socket		25-pin sub-D socket		9-pin sub-D socket		Data
	①	②	①	②	①	②	
R x D	2	2	3	3	2	2	T x D
T x D	3	3	2	2	3	3	R x D
DTR	4		20		4		DSR
Signal Ground	5	5	7	7	5	5	Signal Ground
DSR	6		6		6		DTR
RTS	7		4		7	┌7	CTS
CTS	8		5		8	└8	RTS

① with hardware handshake: When connecting the thermostat to the computer please use a 1:1 cable and not a zero-modem cable!

② without hardware handshake: The computer needs an operating mode: "without hardware handshake". In the plug of the thermostat a bridge has to be inserted between Pin 7 and 8.

- Use screened connecting cables.



- Connect the screen to the plug case.
- The lines are electrically isolated from the remaining electronics.
- Unoccupied pins must not be connected!

The RS 232 Interface can easily be tested with the PC connected, using the MS-Windows operating system.

On Windows 3.11 with the programme "Terminal" and on Windows 95 with the programme "Hyper Terminal".

Protokoll:



- The interface operates with 1 stop bit, no parity bit and 8 data bits.
- Transfer rate either 2400, 4800, 9600 (factory setting) or 19200 baud as selected.
- The RS232 interface can be operated with or without hardware handshake (RTS/CTS).
- The command from the computer must be terminated with CR, CRLF or LFCR.
- The response of the thermostat is always terminated with CRLF.

CR = carriage return (hex: 0D)

LF = line feed (hex: 0A)

Example:: Transfer of setpoint 30.5°C to the thermostat.

Computer	Thermostat
„OUT_SP_00_30.5“CRLF	⇒
⇐	„OK“CRLF

Unit description

3.5.2 RS 485 Interface

Connecting cable:

Thermostat	
9-pin sub-D-socket	
pin	Data
1	Data A
5	SG (Signal Ground) optional
6	Data B



- Use screened connecting cables.
- Connect the screen to the plug case.
- The lines are electrically isolated from the remaining electronics.
- Unoccupied pins must not be connected!

The **RS 485** bus absolutely needs a bus termination in form of a terminating network which ensures a defined unattended time in the high-resistance phases. The bus terminal is defined as follows:

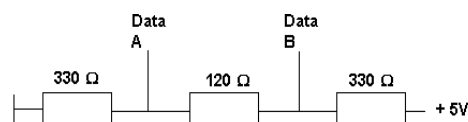

Generally this network is integrated on the plug-in card of the computer (RS 485).

Protocol:



- The interface operates with 1 stop bit, no parity bit and 8 data bits.
- Transfer rate either 2400, 4800, 9600 (factory setting) or 19200 baud as selected.
- The RS485 commands are always preceded by the device address. There is provision for 127 addresses. The address must always have 3 digits. (A000_... to A127_...).
- The command from the computer must be terminated with CR.

- The response of the thermostat is always terminated with CR.
- CR = carriage return (hex: 0D).

Example: Transfer of setpoint 30.5°C to the thermostat with address 15.

Computer	Thermostat
„A015_OUT_SP_00_30.5“CR	⇒
⇐	„A015_OK“CR

Unit description

3.5.3 Write commands (data commands to the thermostat)

Command	Explanation
OUT_SP_00_XXX.XX	Setpoint transfer with up to 3 places before the decimal point and up to 2 places behind
OUT_SP_01_XXX	Pump output step 1, 2, 3, 4, or 5; 0 = Stop (Standby)
OUT_PAR_00_XXX.XX	Setting of control parameter Xp for controller (0.1 – 10°C)
OUT_PAR_01_XXX	Setting of control parameter Tn (5 - 60 sec)
OUT_MODE_00_X	Keys: 0 = free / 1 = inhibited (corresponds to "KEY")
START	Switches thermostat on (from standby).
STOP	Switches thermostat to standby (pump, heating, refrigerator off).



- For "_" use also " " (blank character).
- Response from thermostat "OK" or in case of error "ERR_X" (RS485 interface e.g. "A015_OK" or in case of error "A015_ERR_X").

Permitted data formats:

-XXX.XX	-XXX.X	-XXX.	-XXX	XXX.XX	XXX.X	XXX.	XXX
-XX.XX	-XX.X	-XX.	-XX	XX.XX	XX.X	XX.	XX
-X.XX	-X.X	-X.	-X	X.XX	X.X	X.	X
-.XX	-.X	.XX	.X				

3.5.4 Read commands (data requested from thermostat)

Command	Explanation
IN_PV_00	Read bath temperature (outflow temperature)
IN_PV_01	Read external temperature TE.
IN_SP_00	Read temperature setpoint
IN_SP_01	Read pump output step
IN_SP_03	Read current overtemperature switch-off point
IN_SP_04	Read current outflow temperature limit TiH.
IN_SP_05	Read current outflow temperature limit TiL.
IN_PAR_00	Read current value of Xp
IN_PAR_01	Read current value of Tn (201 = OFF)
IN_PAR_04	Read current value of KPE
IN_PAR_05	Read current value of TNE (201 = OFF)
IN_MODE_00	Keys: 0 = free / 1 = inhibited
IN_MODE_01	Control: 0 = internal / 1 = external
TYPE	Read thermostat type
VERSION	Read software version number
STATUS	Read thermostat status 0 = OK, -1 = error
STAT	Read error diagnosis response: XXXXXXXX → X = 0 no error, X = 1 error Char. 1 = error (Exx) Char. 2 = pump error Char. 3 = low level error Char. 4 = overtemperature error Char. 5 = 0 Char. 6 = no external temp. probe (TE FAIL) Char. 7 = error analogue inputs 0 = OK / 1 = current analogue setpoint input < 4 mA / 2 = current analogue act. temperature input < 4 mA / 3 both current inputs < 4 mA



For "_" use also " " (blank character).

The thermostat response is always in the fixed decimal format "XXX.XX" or for negative values "-XXX.XX" or "ERR_X". (RS485 interface e.g. "A015_XXX.XX" or "A015_-XXX.XX" or "A015_ERR_X").

Unit description

3.5.5 Error messages

Message	Explanation
ERR_2	Wrong input (e.g. buffer overflow)
ERR_3	Wrong command
ERR_5	Syntax error in value
ERR_6	Illegal value
ERR_8	Channel (ext. temperature) not available
ERR_30	Programmer, all segments occupied

3.5.6 Driver software for LABVIEW®

An individual, easy-to-use control and automation software for operating the ECOLINE, INTEGRA and WK/WKL units can be programmed with the aid of the National Instruments program development tool LABVIEW® (<http://sine.ni.com/apps/we/nioc.vp?cid=1381&lang=US>). In order to make program operation possible on the RS 232/ RS 485 interface, LAUDA provides drivers specially designed for LABVIEW® which can be downloaded free of charge under www.lauda.de/spec-e.htm.

4 Unpacking

After the unit and accessories have been unpacked they have to be examined for possible transport damage. If there is any damage visible on the unit, the forwarding agent or the post office has to be notified so that the shipment can be examined.

Standard accessories:

Bath cover	E 203 and on all bath/circulation thermostats E 3xx
Closing plugs	on all bath/circulation thermostats
Warning label 	on all bath/circulation thermostats
Operating Instructions	on all immersion and bath/circulation thermostats

Preparations

5 Preparations

5.1 Assembly and setting up

a) Immersion Thermostat

- Hang the thermostat into the bath to be thermostated (baths > Section 10. Accessories)



- In baths made of plastic the heater should not have contact to the sides of the bath!
- Do not cover the ventilation opening at the back of the unit.
Keep clear distance of at least 20 cm.

Adjustment of the pump chamber

- The fixation of the temperature probe has to be moved upwards approx. 15 mm.
- Adjust the pump chamber.
- Move the fixation of the temperature probe downwards again (see ill. on the left)

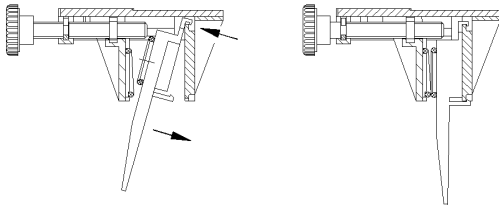
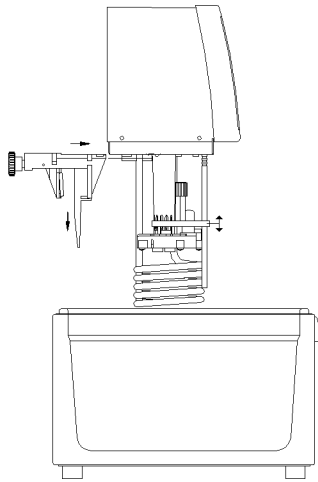

- For all LAUDA baths (plastic and deep-drawn baths), please fix the adapter (standard accessory) on the clamping bracket.
- Turn the jet nozzle to face diagonally into the bath. The outflow for the bath circulation can then be closed.
- Turn the setting knob to the left (see. ill. 1.)

Adjustments of the pump outflows

ill 1

Setting knob turned anticlockwise

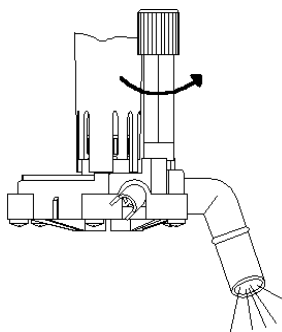

ill 2

Setting knob medium position

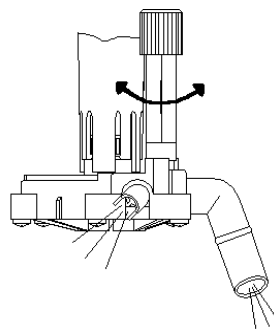

ill 3.

Setting knob turned clockwise

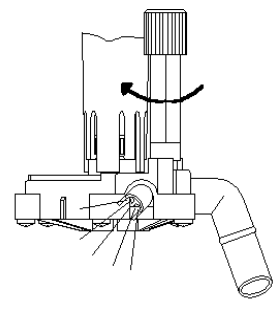

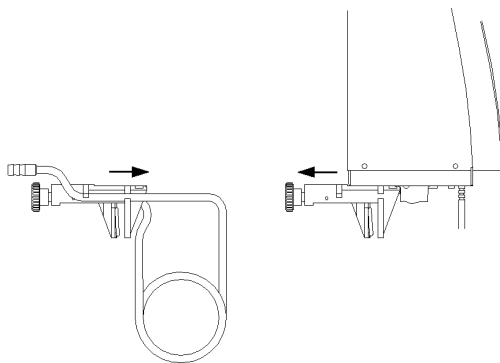

Operation with cooling coil (≥ Section 10. Accessories)

- Pull the clamping bracket to the back for fixing the cooling coil while releasing it with a screwdriver.
- Push the cooling coil on the clamping bracket.
- Install the clamping bracket again.

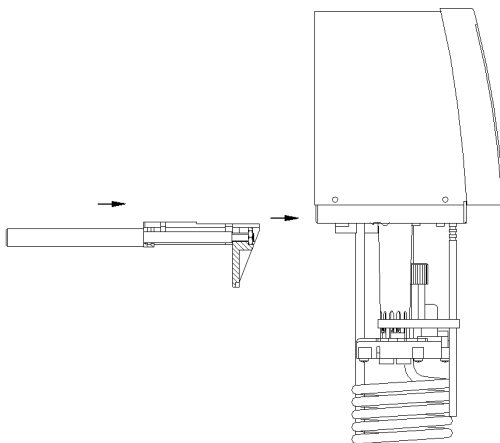

Operation with fixing rod (≥ Section 10. Accessories)

- Pull the clamping bracket to the back while releasing it with a screwdriver.
- Install the fixing rod together with the clamping bracket.

Operation with external circuit (≥ Section 5.4.)



- The immersion thermostats have to be fixed carefully at the bath, for they must not fall into the bath.
- In that case don't touch the bath liquid! Pull out mains plug immediately!

a) Bath/Circulation thermostats

- Place the unit on a flat surface.
-  - Do not cover the ventilation openings at the back.
- Keep a clear distance of at least 20 cm.
- Put the control unit with the bath bridge on the bath
- When operating without an external consumer (bath thermostat) the setting knob has to be turned so that the flow comes out of the outlet for bath circulation (≥ ill. 3, Section 5.1.).

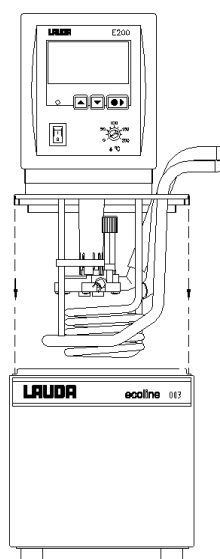

Preparations

b) Operation with external consumer (Circulation thermostat) (≥ Section 5.4.)



- At bath temperature above 70°C the label  supplied must be affixed on the bath in a clearly visible position.
- When operating as bath thermostat without external consumer the pump pressure outflow has to be closed (use closing plugs) or linked to the return.

5.2 Filling and emptying

Filling

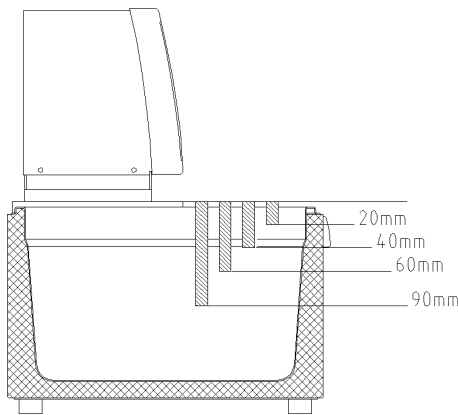

- Fill baths up to a maximum level of 20 mm below the bath bridge.
- Optimum operation at 20-40 mm below the bath bridge.
- Operation is possible down to 60 mm below the bath bridge.
- The low-level cut-out operates at approx. 90 mm below the bath bridge



- When using thermal oils it is necessary to allow an expansion of approx. 8 %/100 °C.
- When operating with an external consumer the total expansion takes place in the bath.

Emptying

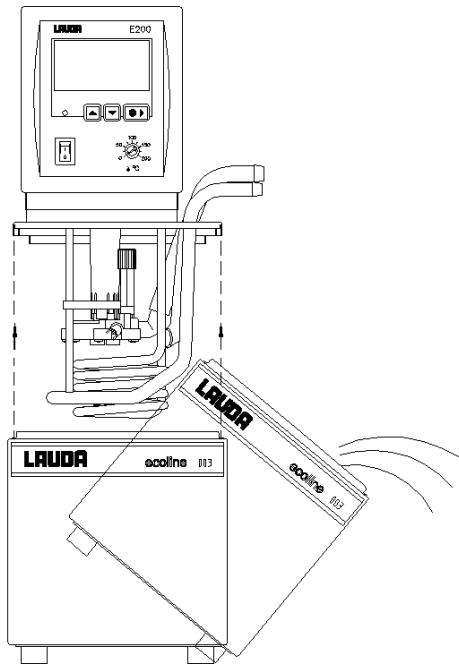

- Switch off the thermostat, pull out the mains plug!
- a) Immersion thermostat, Bath/ Circulation thermostat
- Unscrew the immersion thermostat or take off the control unit with the bath bridge.
- Drain the bath.



- The units are designed for operation with non-flammable and flammable liquids to EN 61010-2-010! Flammable liquids can be operated up to no more than 25°C below the firepoint (≥ Section 5.3).
- Observe the appropriate regulation when disposing used thermostating liquid.
- When connecting an external consumer take care that the level of the bath liquid does not drop too much → fill in bath liquid if necessary.



Do not drain the thermostating liquid when it is hot or very cold (below 0°C)!

Preparations

5.3 Bath liquids and hose connections

Bath liquids

LAUDA Designation		Working temperature range	Chemical Designation	Viscosity (kin)	Viscosity (kin) at Temperature	Fire-point	Ref.No. Quantity		
	Former designation						from °C to °C	at 20°C	mm ² /s
	water	+5...+90	deionised water ①	--	--	--			
Kryo 30 ②	G 100 ②	-30...+90	Mono-ethylene-glycol/water	4	50 at -25°C	--	LZB 109	LZB 209	LZB 309
Kryo 51	---	-50...+120	Silicone oil	5	34 at -50°C	> 160	LZB 121	LZB 221	LZB 321
Kryo 20	160 MS	-20...+180	Silicone oil	11	28 at -20°C	> 230	LZB 116	LZB 216	LZB 316
Ultra 350	330 SCB	+30...+200	synthetic thermal oil	47	28 at +30°C	> 240	LZB 107	LZB 207	LZB 307
Therm 230	RDS 50	+60...+230	Silicone oil	44	28 ... +60°C	> 362	LZB 117	LZB 217	LZB 317



① At higher temperatures → Evaporation losses → Use bath covers (➤ Section 10. Accessories).

Distilled water or fully deionised water must only be used with the addition of 0,1g sodium carbonate (Na₂CO₃) /l water, otherwise → danger of corrosion!

② Water content falls after prolonged operation at higher temperatures

→ mixture becomes flammable (flash point 128°C).

→ Check the mixture ratio with a densiometer.

– When selecting bath liquids it should be noted that performance must be expected to worsen at the lower limit of the operating temperature range due to increasing viscosity. The full operating range should only be utilised if really necessary.

– The operating ranges of the bath liquids and tubing represent general data which may be limited by the operating temperature range of the unit.



Silicone oil causes pronounced swelling of Silicone rubber → never use Silicone oil with Silicone tubing!

DIN Safety data sheets are available on request

Hose connections

a) Elastomer tubing

Tubing type	Int. dia. Ø mm	Temperature range °C	Application	Ref. No.
EPDM-tubing, uninsulated	9	10 to 120	for all bath liquids except for Ultra 350 and mineral oils	RKJ 111
EPDM-tubing, uninsulated	12	10 to 120	for all bath liquids except for Ultra 350 and mineral oils	RKJ 112
EPDM-tubing insulated	12 ext. dia. 35mm approx.	-60 to 120	for all bath liquids except for Ultra 350 and mineral oils	LZS 021
Silicone tubing, uninsulated	11	-30 to 100	water, water/glycol mixture	RKJ 059
Silicone tubing insulated	11 ext. dia. 35mm approx.	-60 to 100	water, water/glycol mixture	LZS 007
Viton	11	-60 to 200	for all bath liquids	RKJ 091



- EPDM-tube, not for Ultra 350 and mineral oils!
- Silicone oil causes pronounced swelling of Silicone rubber → never use Silicone oil with Silicone tubing!
- Protect tubing with hose clips against slipping off.

Preparations

5.4 Connection of external circuits

a) Immersion thermostats

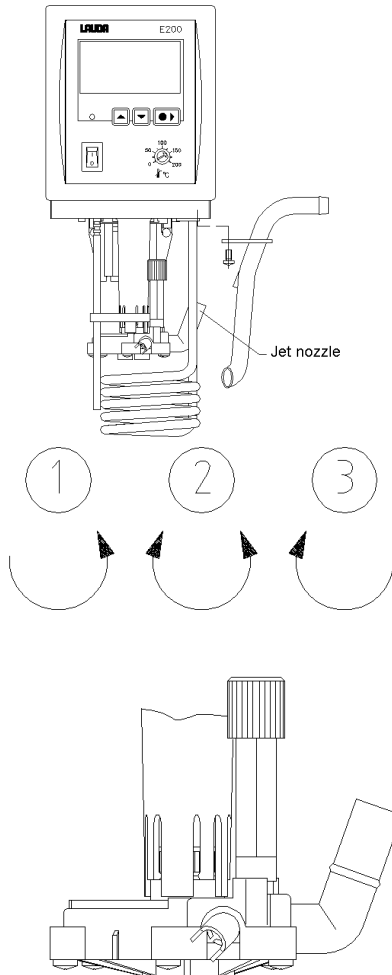

- Push 11-12 mm int. dia. tubing (≥ Section 5.3.) directly onto the jet nozzle and connect it to the external circuit.
- Hang the return tubing into the bath and fix it!
- We recommend to use the pump set (≥ Section 10. Accessories). In this case
- screw on the pump connectors.
- install the connecting tube.
- Using the setting knob at the pump outflows, divide up the pump flow in accordance to the thermostating task.(≥ Section 5.1)
- Position ① → maximum flow in the external circuit, the setting knob is turned anticlockwise.
- Position ② → flow passes through pump outflow and outlet for bath circulation, the setting knob is in medium position.
- Position ③ → external circuit is closed and the outlet for bath circulation fully open, the setting knob is turned clockwise.



- Operate the setting knob only when the bath contents are near ambient temperature.
- When no tubing is connected, close the pump outflow with closing plugs even in position ③.

b) Bath/Circulation thermostat

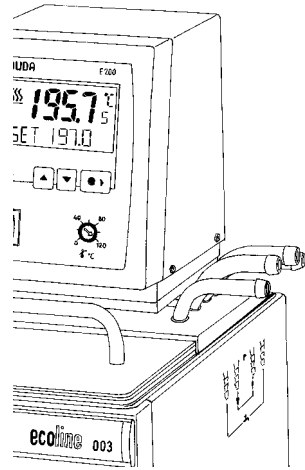

- Connect 11-12 mm int. dia. tubing (➤ Section 5.3.) to the pump connector.
- Pump outflow connection always in front, return connection always at the back.



- If the cross-section of the tubing is too small → temperature drop between bath and external system due to low flow rate. Increase the bath temperature appropriately.
- Always ensure the maximum possible flow cross-section in the external circuit!



- When the external consumer is placed at a higher level than the thermostat, the pump is stopped and air penetrates into the thermostating circuit the external liquid may drain down into the bath even with a closed system → danger of flooding the thermostat!
- Protect tubing with hose clips against slipping off!
- When no external circuit is connected to the thermostat, the outflow connection must be closed (use closing plugs) or linked to the return!

5.5 Cooling the thermostats

At bath temperatures down to just above ambient temperature (approx. 2 – 10°C) it is possible to work without cooling. Additional cooling is required for lower temperatures

Immersion thermostat. → attach the cooling coil (➤ Section 5.1.).

Bath/Circulation thermostats → fitted with cooling coil, as standard..

Cooling possibilities

- . down to 20 °C Mains water → keep the water consumption as low as possible!
- . down to –30°C flow-through cooler DLK 10/ DLK 25 (depending on bath size and temperature) ➤ Section 10. Accessories
→ use water/glycol mixture (ratio 1:1).

Mains supply 230V will be switched off in case of fault. Consumption of current 2A max.



- Use insulated tubing!
- When thermostating an external system the equipment must be arranged in the following order: thermostat → external circuit → flow-through cooler → thermostat

6 Starting up

6.1 Connection to the supply

Compare the supply voltage against the data on the rating label.

Model according to EMC directive EN 61326-1 Class B.*

	<ul style="list-style-type: none"> – Connect the unit only to a grounded mains power socket (PE). – No warranty when the thermostat is connected to a wrong supply! – Without external circuit ensure that the pump pressure outflow is closed or linked to the pump return. – Ensure that the unit is filled in accordance with Section 5.2.!
---	--

6.2 Switching on

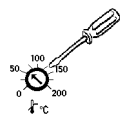

0,25s

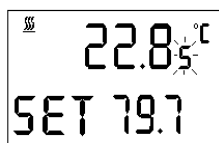

- Using a screwdriver set the overtemperature switch-off point to a value clearly above ambient temperature.
- Switch on at the mains switch.
The green LED for "Supply ON" lights up.
- A tone sounds for approx. 0,25 s.
- The unit self-test starts up. All display segments and symbols light up for approx. 1 s. Then the software version is indicated for approx. 1 s.
- Display shows the actual bath temperature (above) (resolution 0,05 °) and the setpoint. The pump starts up. The values which were active before switching off are entered.
- If necessary add more bath liquid to replace the amount pumped out to the external circuit.
- If the pump does not purge the system immediately. The unit may switch off again although it is filled sufficiently (only when starting up for the first time)..

* Notic only valid for EU countries

Starting up

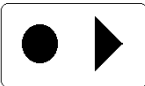

- A double signal tone sounds.
- The display for low-level (LEVEL) appears.
- The fault triangle is flashing
- Press the key. If necessary repeat several times.
- Also press the key if the unit had switched off under a fault condition.

6.3 Setpoint selection (level 0)

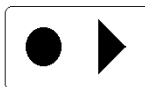
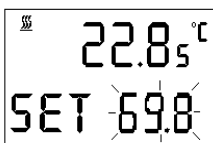
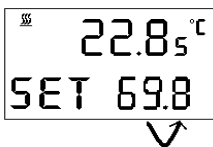
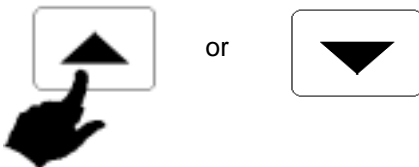

- Input the setpoint with one of the keys.
- Speeding the setting process by:
 - a) continuous pressing the keys or
 - b) pressing one key (holding it down) and shortly pressing the other key.
- Briefly releasing (1 s) the key (s) and again pressing one of the keys moves the cursor one place to the right.
- Display flashes 4 s → the new value is accepted automatically, or
- Value is entered immediately with this key.
- For safety reasons the setpoint can only be adjusted up to 2 °C above the upper limit of the operating temperature range of the particular unit type

6.4 Menu functions

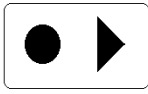

- Switching from setpoint selection (level 0) to level 1 using the key



or



- Within one level it is possible to scroll using the keys.
- **In principle**, after each setting has been made it is entered automatically after approx. 4 s or

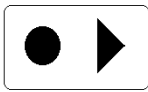

- Settings are entered immediately on operating this key

6.4.1 Pump output

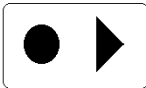

- For setting the pump output starting from level 0, press the key shown on the left.

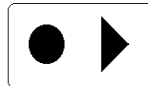
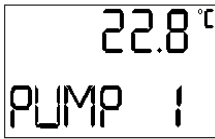

- The display shows the current bath temperature, PUMP and the current output step. To alter the setting press the key shown on the left.

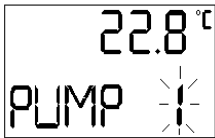

- Display flashes (approx. 4 s).



or

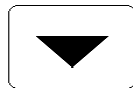

- During this time start to set the required step with one of the keys.
 0 = pump stopped, heating off
 1 = low pump output
 2 , 3 , 4 = medium pump output
 5 = maximum pump output

- The pump responds immediately (can be heard). (Setting is entered after approx. 4 s > Section 6.4.)









- Move forward with key to "Selecting the setpoint resolution" **or**

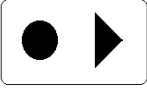

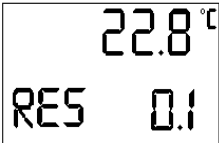
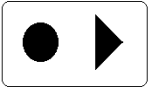
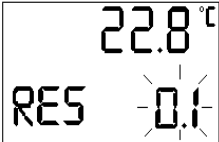

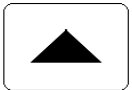

- back with the key to "Setpoint selection".



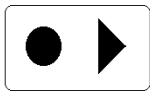
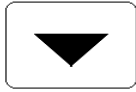

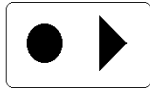
6.4.2 Setting the setpoint resolution

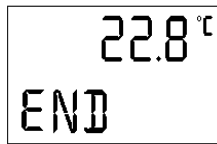
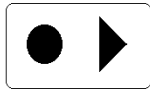
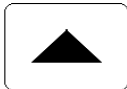
-  and 1x 
- 
-  
- 
-  or 
- 
- 
- To set the setpoint resolution from level 0 press the key combination on the left **or**
 - move forward with the key from the PUMP-function.
 - The current bath temperature, RES and the current setpoint resolution are indicated.
 - To alter the setting, press the key on the left.
 - Display flashes (approx. 4 s).
 - During this time, start to set the required resolution with one of the two keys.
normal setting → 0,1 = 0,1 °C setpoint resolution, **or**
0,01 = 0,01 °C setpoint resolution. During setpoint input only S is indicated instead of SET.
 - Forward with the key to "parameter level" **or**
 - with key back to "PUMP".

6.4.3 Parameters

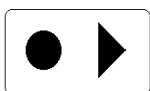
-  and 2x 
 - Directly from level 0 (setpoint selection) press the key combination on the left, **or**
 - forward with the key from setpoint resolution function.
- 
 - forward with the key from setpoint resolution function.
-  
 - Here it is possible to switch over to level 2. Press the key on the left, continue with Section 6.4.3.1. **or**
- 
 - with key to step END.
-  
 - End of the menu.
 - Return to level 0 (setpoint selection) with the key on the left, **or**
 - with key back to "Setting the setpoint resolution".
- 

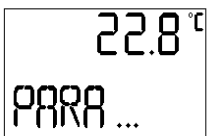
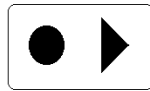
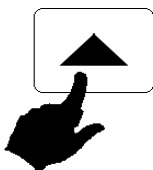
6.4.3.1 Setting the proportional band of the PID-controller

-  and 2x 
 - Directly from level 0 (setpoint selection), press the key combination on the left, until the PARA -function is reached, **then**
-  
 - switch to level 2 from PARA (see above) with key on the left.
-  **or** 
 - Within this level it is possible to scroll with the keys.

Starting up

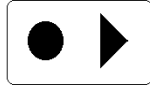

- The display shows the current bath temperature Xp and the current setting. To alter the setting press the key on the left. Available settings from 0,5 to 9,9 °C .
(> Section 6.4.3.2. Note).
(> Section 9. Technical data)



- Display flashes (approx. ca. 4 s).

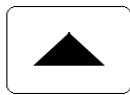

or

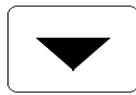

- During this time start to set the required value with one of the two keys.



- Forward with the key to "Setting the reset time" **or**

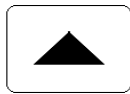

- with the key back to "PARA".

6.4.3.2 Setting the reset time of the PID-controller

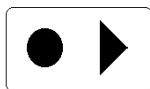

and 2x



- Directly from level 0 (setpoint selection), press the key combination on the left (top one on E 3xx, bottom one E 2xx), until the PARA function is reached, then

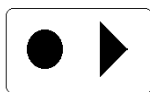

and 1x



- switch to level 2 and move forward with the keys on the left.

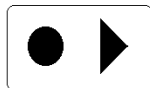
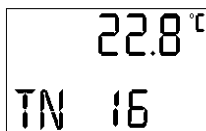

- The display shows the current bath temperature, Tn and the current setting. To alter the setting, press the key on the left. → Possible adjustment from 5 to 60 s

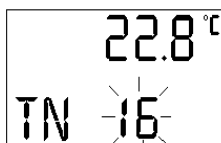

- The display is flashing (approx. 4 s).

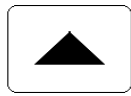

or

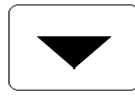

- During this time, start to set the required value with one of the two keys.



- Forward with the key to "Selection of the interface" **or**

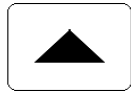

- with key back to "Setting the proportional band".



- The control parameters are pre-set to suit the unit type.

Normally no change is required. Some adjustment is necessary only when using Silicone oil and with very stringent demands on short-term stability. If there are control fluctuations, increase the values for Xp and Tn. If the setpoint is not reached → select smaller values. The derivative time Tv (D-part) is altered automatically through a fixed factor to Tn.

(Standard settings of control parameters and pump ➤ Section 9. Technical data)

6.4.3.3 Selection of the interface

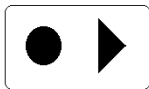

and 2x



- Directly from level 0 (setpoint selection), press the key combination on the left, until the PARA function is reached, **then**

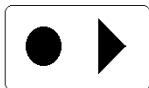

and 2x



- switch to level 2 and move forward with key on the left.

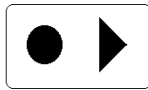
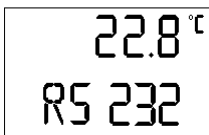

- The display shows the current bath temperature and the currently set interface. To alter the setting press the key.

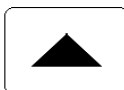

or



- Display flashes (approx. 4 s.). During this time start to set the required interface with one of the keys.

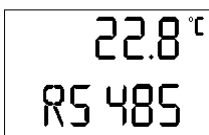

- Having chosen the RS 485 interface press the key.

Starting up

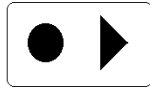
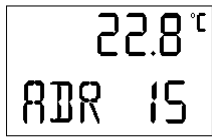

- The display shows the current bath temperature, ADR and the current unit address (e.g.. 15). Press the key, display flashes (approx. 4 s.).

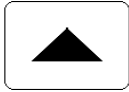

or

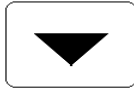

- During this time start to set the required unit address. (possible setting: 000...127)



- Forward with key to "Setting the baud rate" or

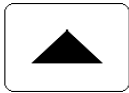

- back with key to "Selection of the interface" resp. when pressing the key twice you return to "Setting the reset time..."

6.4.3.4 Setting the Baud rate/ transfer rate (serial interface)

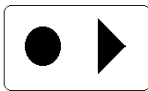

and 2x



- Directly from level 0 (setpoint selection), press the key combination on the left, until the PARA function is reached, **then**

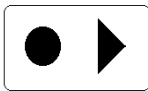

and 3x

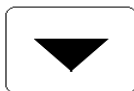

- switch to level 2 and move forward with key on the left.

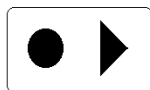
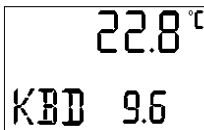

- The display shows the current bath temperature, KBD and the current setting. To alter the setting press the key.

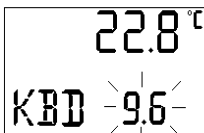

- Display flashes (approx. 4 s).



or



- During this time, start to set the required value with one of the two keys. Settings available: 2400, 4800, 9600 or 19200 baud



- Forward with key to "user calibration" or

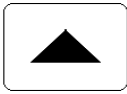

- with key back to "Selection of the interface".

6.4.3.5 User calibration



- Remove the external consumers and switch the setting knob of the pump to right side. (>Section 5.4).
- A reference thermometer with necessary accuracy is required. Otherwise the factory calibration should not be altered. The reference thermometer has to be inserted far enough and long enough into the bath.
- It is not allowed to calibrate to more than ± 3 °C. Multiple calibration to more than ± 3 °C cause internal faults (after 2 min "E1006" or "e16").
- **The factory calibration will be lost through overwriting → please work carefully!!!**

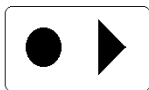

and 2x



- Directly from level 0 (setpoint selection), press the key combination on the left, until the PARA-function is reached, **then**

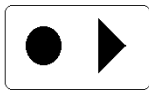

and 4x



- switch to level 2 and move forward with key on the left.

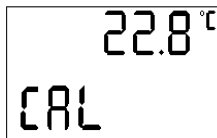

>2,5 s

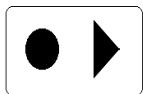

1. The display shows CAL and the current bath temperature. To carry out a calibration, press the key longer than 2.5 s.

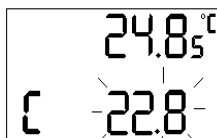

2. The actual value appears.



or

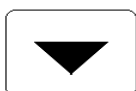

3. Input the value indicated on the reference thermometer with one to the two keys.

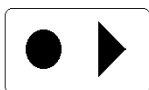

4. The additive calibration must be entered with the key shown on the left.

Starting up



5. Forward with key to "END", then

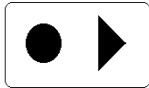

6. Switch back to level 0 or

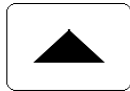

7. with key back to "Setting the transfer rate".

Example

- a) Insert a suitable thermometer into the bath (long enough and far enough).
- b) Remove the external consumers and turn the setting knob of the pump outflows to the right side.
- c) Set the setpoint to a temperature where you use to work (e.g. set the setpoint to 45°C (≥ Section 6.3.))
- d) Wait until the actual bath temperature has reached the setpoint temperature of 45°C and until the indication on the reference thermometer does not change any more.
- e) The reference thermometer shows e.g. 44,8 °C.
- f) Select CAL on the display and go forward as mentioned under point 1-7 (see above). The actual bath temperature switches from 45°C to 44,8°C and the unit starts to heat up until the actual bath temperature has reached 45°C. (→ the reference thermometer should also indicate 45°C).

6.5 Warning and safety functions

6.5.1 Overtemperature protection and testing



- The units are designed for operation with non-flammable and flammable liquids to EN 61010-2-010!

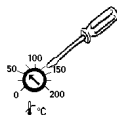

- Set the overtemperature switch-off point. Recommended setting 5°C above required bath temperature.



- Not higher than 25 °C below the firepoint of the bath liquid (≥ Section 5.3.).

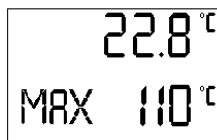

- The actual switch-off point is indicated on the display, e.g. 110°C.



- When the switch-off point is being adjusted by more than 2°C → display shows MAX and actual overtemperature switch-off point with 1°C resolution for approx. 4 s.
- The position of the potentiometer is decisive for the setting. The display is just a help for the setting.
- Setting is possible only up to a upper limit of the operating temperature range + 5 °C.



- When the bath temperature arises above the overtemperature switch-off point.

1. Double signal tone sounds.
2. The display shows the indication for overtemperature (TEMP) the fault triangle is flashing
→ heating is switched off on both poles,
→ pump is switched off by the electronics

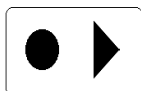
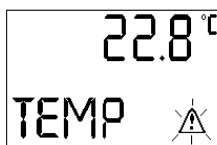

- Rectify the cause of the fault.
- Wait until the bath temperature has cooled down below the switch-off point or set the switch-off point at a higher value.
- When the display shows TEMP, reset with the key.



- Before the unit is run is running unattended for longer periods **overtemperature protection** should be tested. **Therefore:**

Starting up

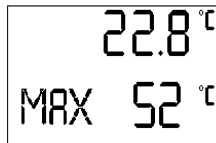
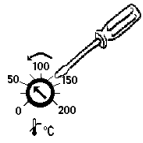

- Turn the potentiometer slowly anticlockwise. → The unit must switch off at the bath temperature.

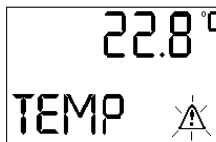
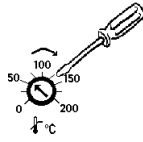

- Step 1 - 2 (see above) must follow.
- Set the overtemperature switch-off point again above the bath temperature and wait until the indication TEMP appears on the display, then

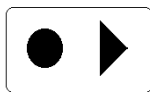

- reset with the key.

6.5.2 Low-level protection and testing



- Double signal tone sounds, if the bath liquid falls so much that the heater is no longer covered with liquid completely.

1. The display shows LEVEL (low-level) and the fault triangle is flashing
 - heating is switched off on both poles,
 - pump is switched off by the electronics

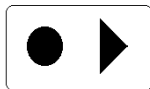

2. Top up the bath > Section 5.2 and reset with the key.



- If necessary repeat several times in case that the pump does not purge immediately.
- Testing at regular intervals by lowering the bath level. Place a hose on the pump connector and pump some of the bath liquid into a suitable container.
- Step 1 - 2 must follow.



- Bath temperature during this test not below 0°C or higher than 50°C, otherwise danger of burn injuries !
- If there is any irregularity when testing the safety devices, switch off the unit immediately and pull out the mains plug !
- Have the unit checked by the LAUDA service or the local service organisation!

6.5.3 Pump motor monitoring



- In case of pump motor overload or a blockage the heating and the pump are switched off.



- Double signal tone sounds.

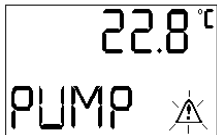

- The display shows PUMP and the fault triangle is flashing
- Rectify the cause of the fault, i.g. clean the pump or check the viscosity, then

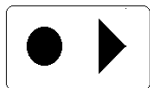

- reset with the key.
- If several faults appear simultaneously, they have to be reset individually

6.5.4 Connection floating contact "Combination fault" 31 N

(Alarm out) 3-pole locking connector

1 = common, 2 = n.c. (break) , 3 = n.o. (make). When the unit is o.k. 1 and 3 are closed (see ill.). Max contact rating: 0.2A 24 V. 3-pin plug (➤ Section 10. Accessories).

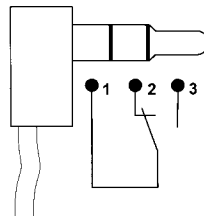

- Contact operates in case of error at overtemperature protection, low-level protection, pump monitoring or any other error message.

Starting up

6.5.5 Other error messages

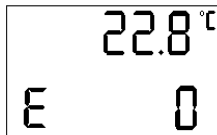

– E 0 etc. is flashing in the bottom line.

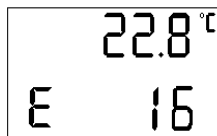
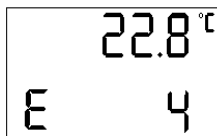

→ various temperature probe faults.

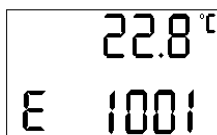
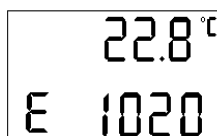
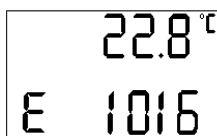
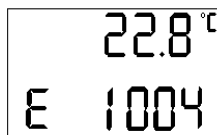
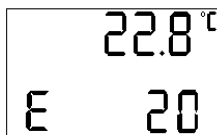

→ pump fault, proceed as in Section 6.5.3.



- If the fault report is repeated → pull out the mains plug and try whether the motor can be rotated by the fan blade inserting a screwdriver into the ventilation opening at the back of the unit.
- Error code 0 ...255 → microprocessor error.
- Error code 1000...1255 → slave processor error.
- Indication can be used for remote diagnosis.

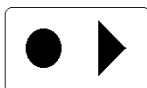

– After rectifying the fault, reset with the key.

7 Safety notes

7.1 General safety notes

A laboratory thermostat is intended for heating and pumping liquids according to the needs of the user. This leads to hazards by high temperatures, fire, and the general hazards by the use of electrical energy.

The user is largely protected through the application of the appropriate standard specifications.

Additional hazards may arise from the type of material being thermostated, e.g. when going above or below certain temperature levels or through breaking of the container and reaction with the thermostating liquid.

It is not possible to cover all possibilities; they remain largely within the responsibility and the judgement of the user.

The unit must only be used as intended and as described in these Operating Instructions. This includes operation by suitably instructed qualified personnel

The units are not designed for use under medical conditions according to EN 60601-1 or IEC 601-1 !

7.2 Other safety notes

- Connect the unit to a grounded mains power socket.
- Parts of the bath cover may reach surface temperatures above 70 °C when operating at higher temperatures. Take care when touching it!
- Use suitable hoses ➤ Section 5.3.
- Protect tubing with hose clips against slipping off. Prevent kinking of tubing!
- Check tubing from time to time for possible material defects.
- Heat transfer tubing and other hot parts must not come into contact with the supply cable!
- When using the thermostat as circulation thermostat, failure of tubing may lead to leaking of hot liquid and become a danger to personnel and objects.
- When no external consumer is connected to the thermostat the pump outflow connection must be closed (use closing plugs) or linked to the return.
- Don't change the pump connections with the connections of the cooling coil!
- Allow for expansion of the bath oil at elevated temperatures
- Depending on the bath liquid used and the mode of operation it is possible for toxic vapours to be

Safety notes

produced. Ensure appropriate ventilation!

- Immersion thermostats have to be fixed carefully at the bath vessels!
- Only use bath vessels which are appropriate for the intended operating temperatures!
- When changing the bath liquid from water to oil, for temperatures above 100 °C, carefully remove all traces of water, also from tubing and from the external consumer, otherwise → danger of burns through delayed boiling!
- The cooling coil with the cooling water has only to be used for operating temperatures below 100°C. At higher temperatures → danger of hot vapour to be produced!
- Always pull out the mains plug before cleaning, maintenance or moving the thermostat!
- Repairs on the control unit and the refrigeration system must be carried out by properly qualified personnel only!
- Values for temperature control and indicating accuracy apply under normal conditions according to DIN 58966. High-frequency electromagnetic fields may under special conditions lead to unfavourable values. This does not affect the safety.

8 Maintenance

8.1 Cleaning

	Before cleaning the unit, pull out the mains plug!
---	--

The unit can be cleaned with water adding a few drops of detergent (washing up liquid), using a moist cloth.

	Water must not enter the control unit!
---	--



- Carry out appropriate detoxification if dangerous material has been spilled on or inside the unit.
- Method of cleaning and detoxification are decided by the special knowledge of the user. In case of doubt please contact the manufacturer!

8.2 Maintenance and repair

	<ul style="list-style-type: none"> - Before any maintenance and repair work pull out the mains plug! - Repair on the control unit must only be carried out by properly qualified personnel!
---	---

LAUDA thermostats are largely maintenance-free. If the thermostating liquid becomes dirty it has to be replaced (> Section 5.2.).



- If a fuse blows (→ supply indication not alight) fit only fuses as specified (2 x T 16 A; 1 x T 2,5 A, size 5 x 20 → fuses are inside the unit).

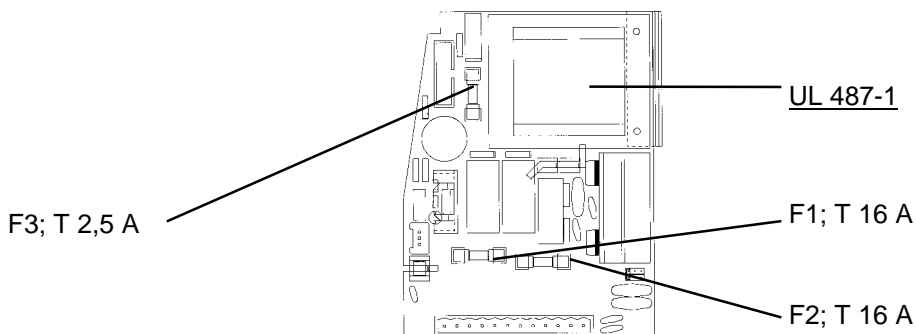

8.3 Ordering spares

When ordering spares please quote instrument type and serial number from the rating label. This avoids queries and supply of incorrect items.

We shall always be happy to deal with queries and to receive suggestions and criticism

LAUDA DR. R. WOBSE
GMBH & CO.KG
P.O. Box 1251
97912 Lauda-Königshofen
GERMANY
Phone: (+49) (0) 9343/ 503-0
Fax: (+49) (0) 9343/ 503-222
E-mail info@lauda.de
Internet <http://www.lauda.de>

9 Technical data (to DIN 58966)

Common technical data

			E 200
Ambient temperature range		°C	5 to 40
Setting resolution		°C	0.1/ 0.01
Indication resolution		°C	0.05
Indication accuracy		°C	± 0,2 °C additive re-calibration ②
Temperature control		± °C	0,01
Safety features ①			FL
Additional functions			LCD Display two line
Power consumption	230 V;50/60 Hz	kW	2.3
	115 V; 60 Hz		1.4
	100 V:50/60 Hz		1.1

① FL: suitable for flammable and non-flammable liquids; NFL: only suitable for non-flammable liquids

② > Section 7.2. last item

Immersion thermostats

			E 200
Operating temperature range ①		°C	25 to 200
" with water cooling		°C	20 to 200
Operating temperature range ②		°C	-20 to 200
Interface			RS 232, RS 485
Heater power	230 V; 50/60 Hz		2.25
	115 V; 60 Hz		1.3
	100 V; 50/60 Hz		1.0
Pump type			pressure pump with choice of 5 output steps
Max. discharge pressure ③		bar	0.4
Max. flow rate③		l/min	20
Pump connections		mm	nipples 13 mm dia.
Bath depth ④		mm	min 150
Usable depth ④		mm	min 100
Overall size (WxD)		mm	125x133
Height (H)		mm	315
Weight		kg	3
Ref. No.	230 V; 50/60 Hz		LCE 0222
	115 V; 60 Hz		LCE 4222
	100 V; 50/ 60Hz		LCE 6222

① at pump output step 1

② with additional cooling

③ at pump output step 5

④ baths > section 10. Accessories

Bath/Circulation thermostats

Technical data

			E 203	E 211	E 219	E 225
Operating temperature range ①		0	23 to 150			
"with water cooling		°C	20 to 150			
Operating temperature range ②		°C	-20 to 150			
Heater power	230 V; 50/60 Hz	kW	2.25			
	115 V; 60 Hz		1.3			
	100 V; 50/60 Hz		1.0			
Pump type			pressure pump with choice of 5 output steps			
Max. discharge pressure ③		bar	0.4			
Max. flow rate ③		l/min	17			
Pump connections		mm	nipples 13 mm dia.			
Max. bath volume		l	3.5	12	18	25
Bath			deep-drawn inner vessel, steel casing painted			
Bath opening (WxD)		mm	135x105	300x190	300x365	300x365
Bath depth ④		mm	150	150	150	200
Usable depth ④		mm	130	130	130	180
Height top edge of bath		mm	178	178	178	228
Overall size (WxD)		mm	168x271	331x360	331x536	331x536
Height		mm	349	349	349	399
Weight		kg	6	9	10	12
Ref. No.	230 V; 50/60 Hz		LCB 0692	LCB 0694	LCB 0696	LCB 0698
	115 V; 60 Hz		LCB 4692	LCB 4694	LCB 4696	LCB 4698
	100 V; 50/ 60Hz		LCB 6692	LCB 6694	LCB 6696	LCB 6698

			E 206 T	E 212 T	E 215 T	E 220 T
Operating temperature range ①		°C	23 to 100			
" with water cooling		°C	20 to 100			
Operating temperature range ②		°C	-20 to 100			
Heater power	230 V; 50/60 Hz	kW	2.25			
	115 V; 60 Hz		1.3			
	100 V; 50/60 Hz		1.0			
Pump type			pressure pump with choice of 5 output steps			
Max. discharge pressure ③		bar	0.4			
Max. flow rate ③		l/min	17			
Pump connections		mm	nipples 13 mm dia.			
Max. bath volume		l	7	13	15	20
Baths			polycarbonate			
Bath opening (WxD)		mm	130x285	300x175	275x130	300x350
Bath depth ④		mm	160	160	310	160
Usable depth ④		mm	140	140	290	140
Height top edge of bath		mm	170	208	356	208
Overall size (WxD)		mm	145x435	316x330	428x142	316x506
Height		mm	330	369	517	369
Weight		kg	4	7	6	8
Ref. No.	230 V; 50/60 Hz		LCM 0092	LCD 0262	LCD 0264	LCD 0266
	115 V; 60 Hz		LCM 4092	LCM 4262	LCM 4264	LCM 4266
	100 V; 50/ 60Hz		LCM 6092	LCM 6262	LCM 6264	LCM 6266

① at pump output step 1

② with additional cooling

③ at pump output step 5

④ baths > section 10. Accessories

Units to EU-Directive 89/ 336/ EWG (EMC) and 73/ 23/ EWG (low-voltage) with CE-mark.

Standard settings of control parameters > Section 6.4.3.1. and 6.4.3.2. and 6.4.2.

Equipment types	Xp (°C)	Tn (s)	Pump output step
E 200	3,0	30	2
E 203	6,0	20	1
E 211, E 212 T	2,5	25	2
E 206 T	4,0	25	2
E 215 T	2,0	25	3
E 219	2,0	30	3
E 225, E 220 T	2,0	30	4

We reserve the right to make technical alterations!

Pump characteristics

Immersion thermostats

measured with water

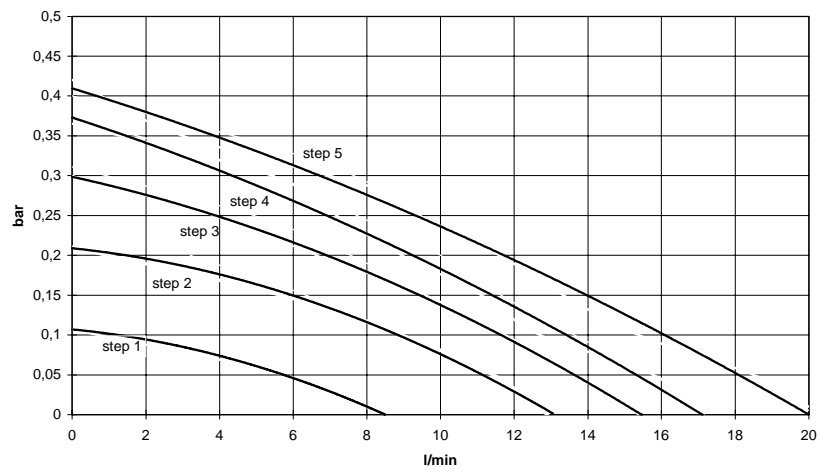

Bath/ Circulation thermostats

measured with water

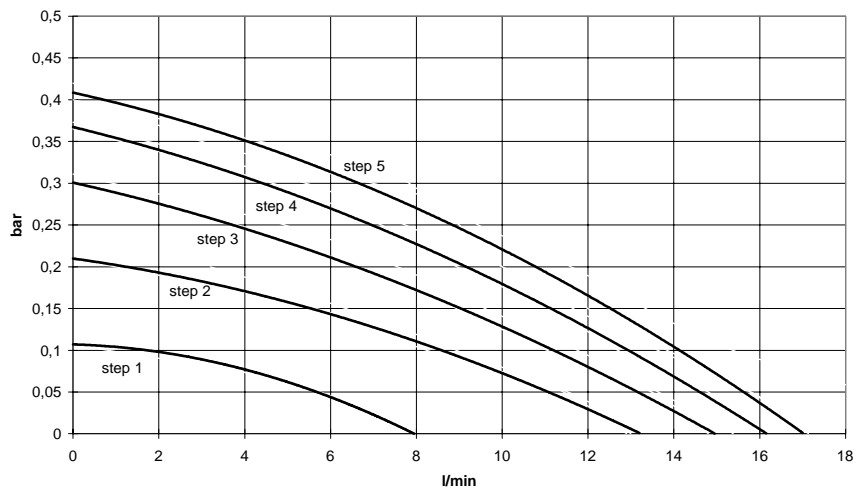

10 Accessories

Immersion thermostats

Accessories	Ref. No.
Cooling coil	HOK 064
Pump set (outflow and return connection)	LCZ 0638
Fixing rod	LCZ 0637

Bath	Materials	Max. Temp (°C)	Volume (l)	Inner size (WxDxH)	Ref. No.
006 T	polycarbonate	100	5 to 7	130x420x160 *	LCZ 0628
015 T	polycarbonate	100	10 to 5	416x130x310	LCZ 0630
020 T	polycarbonate	100	14 to 20	300x490x160	LCZ 0631
012 T	polycarbonate	100	9 to 13	300x315x160	LCZ 0629
003	deep-drawn stainless steel	150	2.5 to 3.5	135x240x150 *	LCZ 0620
011	deep-drawn stainless steel	150	9 to 12	300x329x150 *	LCZ 0621
019	deep-drawn stainless steel	150	12 to 18	300x505x150 *	LCZ 0622
025	deep-drawn stainless steel	150	19 to 25	300x505x200 *	LCZ 0623
006	stainless steel	200	3.5 to 5.5	150x260x160	LCZ 0624
012	stainless steel	200	8 to 13	300x305x160	LCZ 0625
020	stainless steel	200	13. to 20	300x480x160	LCZ 0626
026	stainless steel	200	19 to 26	300x480x200	LCZ 0627
040	stainless steel	200	30 to 40	300x750x200	LCZ 029

Accessories

Bath / Circulation thermostats

Accessories	suitable for	Ref. No.
Bath cover	E 211	HDQ 079
Bath cover two parts	E 219, E 225	LCZ 0632
Gable cover	E 220 T	LCZ 011
Gable cover	E 219, E 225	LCZ 0634
Cover plate MD 15 K	E 215 T	LSZ 0115
Cover plate MD 15 V	E 215 T	LCZ 041
Cover plate MD 15 V/K	E 215 T	LCZ 040
Rising platform 8 steps	E 203	LCZ 0645
Rising platform 8 steps	E 206 T	LCZ 0648
Rising platform 8 steps	E 212 T, E 211, E 312, E 120 T, E 220 T, E 219, E 225	LCZ 0635
Through-flow cooler DLK 10 to -10 °C		LFD 005
Through-flow cooler DLK 25 to -30 °C		LFD 108
3-pole locking connector (floating contact „Combination fault“ 31 N)		EQS 054
Wintherm Software under Windows	for all units	LDSE 4001

For further information please contact us.

11 Circuit diagram

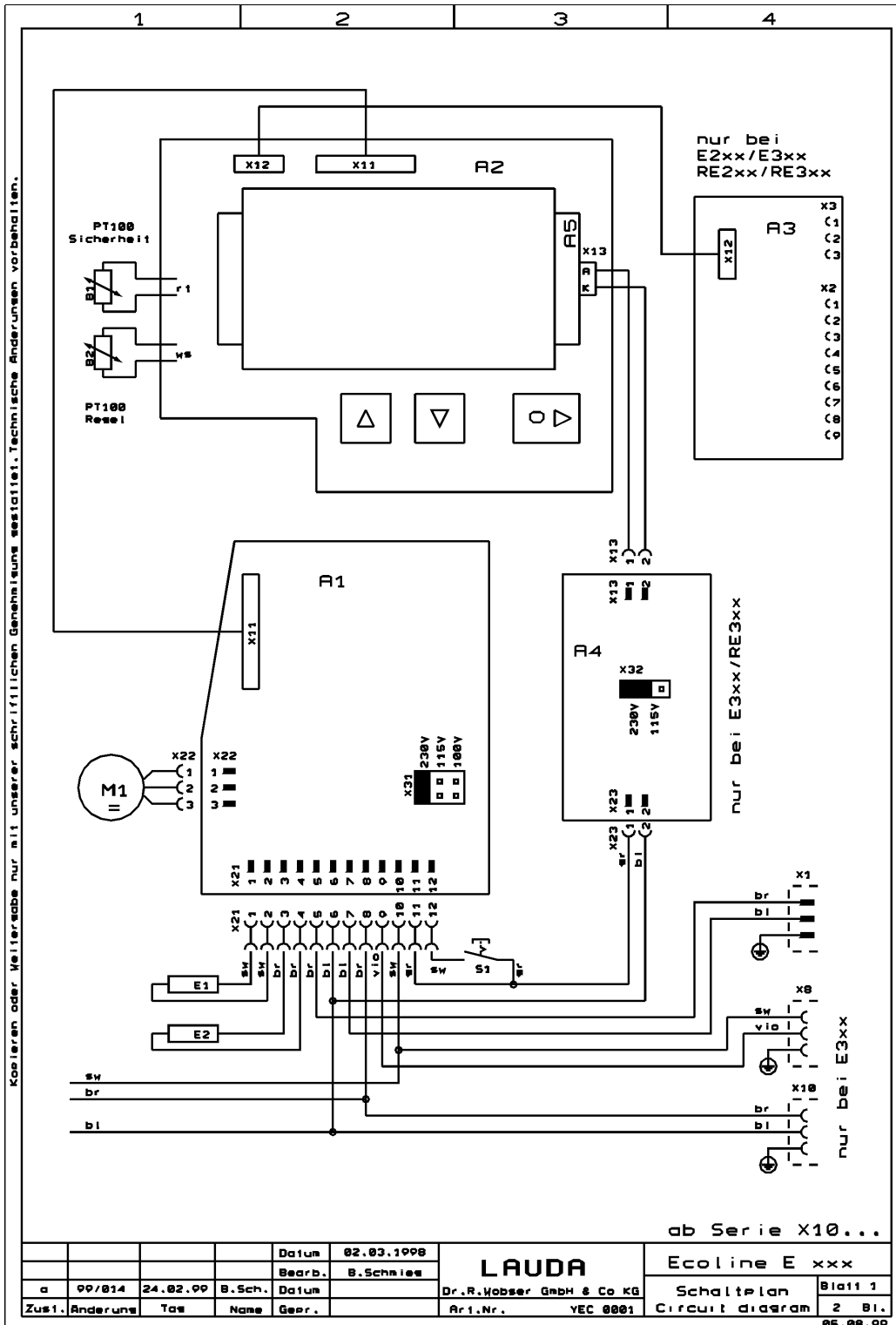

Circuit diagram

230V; 50Hz ◆ 230V; 50/60Hz ◆ [230V; 60Hz]

at serial no: X01

		E 1xx	E 2xx
A 1	Printed circuit board „Mains“	UL 487-1	UL 487-1
A 2	Printed circuit board „Display“	UL 488-1A	UL 488-1B
A 3	Printed circuit board serial interface RS 232/RS 485	-----	UL 490
A 4	Printed circuit board Mains LED-Backlight	-----	-----
A 5	Printed circuit board Display LED-Backlight	-----	-----
B 1	Pt100 probe safety circuit	ETP 057	ETP 057
B 2	Pt100 probe actual value		
E 1	Heater 1,5 kW	EH 168	-----
E 2	Heater 2,25 kW	-----	EH 169
M 1	Pump motor	EM 109	EM 109
S 1	Mains switch	EST 101	EST 101
U 3	SSR (BRT22H) Y 1 output A1	-----	EYI 158
X 1	Mains connection	EKN 001	EKN 001
X 2	Lock screw	-----	2x EQZ 048
X 8	Connection socket Cooling (Stakei 2)	-----	-----
X 10	Connection socket Cooling unit (Stakei 200)	-----	-----
X 13	Housing 2pol.	-----	-----
X 21	Plug strip terminal 12pol.	EQF 079	EQF 079
X 23	Line up terminal 2pol.	-----	-----

115V; 60Hz ◆ [100V; 50/60Hz]

at serial no: X01

		E 1xx	E 2xx
A 1	Printed circuit board „Mains“	UL 499	UL 499
A 2	Printed circuit board „Display“	UL 488-1A	UL 488-1B
A 3	Printed circuit board serial interface RS 232/RS 485	-----	UL 490
A 4	Printed circuit board Mains LED-Backlight	-----	-----
A 5	Printed circuit board Display LED-Backlight	-----	-----
B 1	Pt100 probe safety circuit	ETP 057	ETP 057
B 2	Pt100 probe actual value		
E 1	Heater 1,3 kW at 115V 1,0 kW at 100V	EH 171	EH 171
M 1	Pump motor	EM 109	EM 109
S 1	Mains switch	EST 101	EST 101
U 3	SSR (BRT22H) Y 1 output A1	-----	EYI 158
X 1	Mains connection	EKN 003	EKN 003
X 2	Lock screw	-----	2x EQZ 048
X 8	Connection socket Cooling (Stakei 2)	-----	-----
X 10	Connection socket Cooling unit (Stakei 200)	-----	-----
X 13	Housing 2pol.	-----	-----
X 21	Plug strip terminal 12pol.	EQF 079	EQF 079
X 23	Line up terminal 2pol.	-----	-----

An / To / A:

LAUDA Dr. R. Wobser • LAUDA Service Center • Fax: +49 (0) 9343 - 503-222

Von / From / De :

Firma / Company / Entreprise: _____

Straße / Street / Rue: _____

Ort / City / Ville: _____

Tel.: _____

Fax: _____

Betreiber / Responsible person / Personne responsable: _____

Hiermit bestätigen wir, daß nachfolgend aufgeführtes LAUDA-Gerät (Daten vom Typenschild):

We herewith confirm that the following LAUDA-equipment (see label):

Par la présente nous confirmons que l'appareil LAUDA (voir plaque signalétique):

Typ / Type / Type :	Serien-Nr. / Serial no. / No. de série:

mit folgendem Medium betrieben wurde

was used with the below mentioned media

a été utilisé avec le liquide suivant

Darüber hinaus bestätigen wir, daß das oben aufgeführte Gerät sorgfältig gereinigt wurde, die Anschlüsse verschlossen sind, und sich weder giftige, aggressive, radioaktive noch andere gefährliche Medien in dem Gerät befinden.

Additionally we confirm that the above mentioned equipment has been cleaned, that all connectors are closed and that there are no poisonous, aggressive, radioactive or other dangerous media inside the equipment.

D'autre part, nous confirmons que l'appareil mentionné ci-dessus a été nettoyé correctement, que les tubulures sont fermées et qu'il n'y a aucun produit toxique, agressif, radioactif ou autre produit nocif ou dangereux dans la cuve.

Stempel Seal / Cachet.	Datum Date / Date	Betreiber Responsible person / Personne responsable

Formblatt / Form / Formulaire:

Unbedenk.doc

Erstellt / published / établi:

LSC

Änd.-Stand / config-level / Version:

0.1

Datum / date:

30.10.1998

LAUDA DR. R. WOBSE GmbH & Co. KG

Pfarrstraße 41/43

D - 97922 Lauda-Königshofen

Internet: <http://www.lauda.de>

Tel: +49 (0)9343 / 503-0

Fax: +49 (0)9343 / 503-222

E-mail: info@lauda.de