

# Sartorius Master<sup>pro</sup> Series

LA Models  
Electronic Analytical and Precision Balances  
Operating Instructions

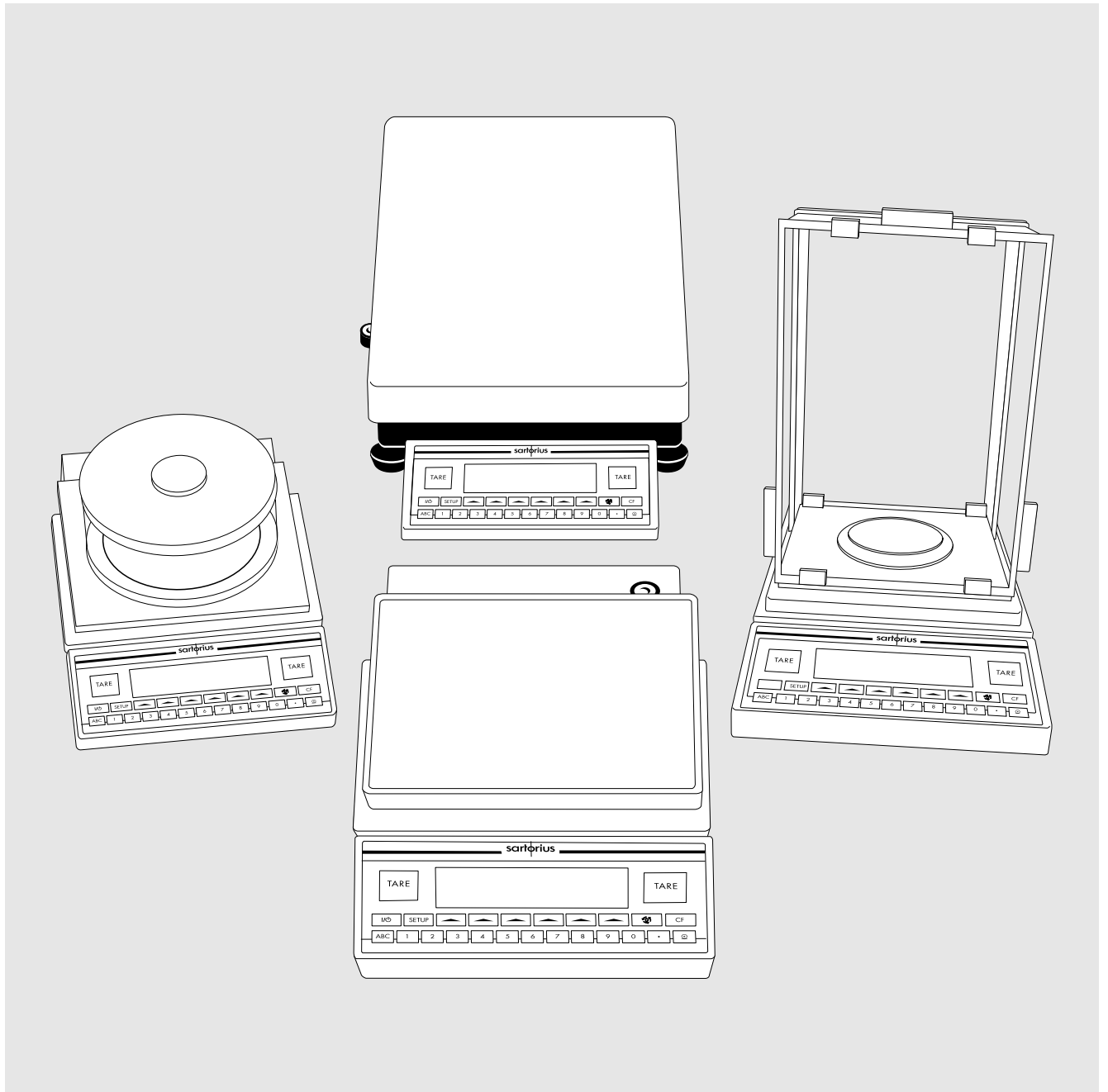

## Intended Use

The Master<sup>PRO</sup> Series from Sartorius offers precision balances for measurement of mass (weight). The balances in this series have capacities ranging from 0.1 mg to 64 kg.

A broad range of special performance features make the Master<sup>PRO</sup> balances ideal for use as measuring and test equipment in ISO or GLP quality management systems. These features include:

- The fully automatic self-calibrating and adjustment function, isoCAL (time- and temperature-dependent)
- reproTEST for quick determination of the standard deviation to check the reproducibility of results
- ISO/GLP-compliant recording capability for printouts
- Password-protected menu lock

Master<sup>PRO</sup> balances meet the highest requirements on the accuracy and reliability of weighing results through the following features:

- Efficient filtering-out of vibration
- Stable and reproducible results
- Excellent readability under any lighting conditions
- Rugged, durable weighing system

Master<sup>PRO</sup> balances save work and speed up simple routine applications through:

- Ultrafast response times
- Built-in application programs, including

### Application 1:

- Toggling between two weight units
- Counting
- Weighing in percent
- Animal weighing
- Recalculation
- Calculation
- Density determination

### Application 2:

- Checkweighing
- Time-controlled functions

### Application 3:

- Totalizing
- Formulation
- Statistics

with the following additional functions:

- Second tare memory
- Identification Codes
- Product data memory
- Manual data storage in Application 3
- Automatic initialization when you switch on the balance
- Easy input of alphanumeric sample, lot and balance IDs
- Flexible, easy-to-use display and control unit
- Connectivity for control through an on-line computer

## Contents

<b>Intended Use</b> .....	2
<b>Safety Precautions</b> .....	3
<b>Operating Design</b> .....	3
<b>Getting Started</b> .....	7
<b>Configuring the Balance</b>	
Setting the Language .....	12
Entering User Data (Input) .....	13
Entering Date and Time .....	15
Application Menu Settings .....	17
Balance Operating Menu .....	28
Configuring the Printout .....	33
Displaying "Info" .....	36
<b>Operating the Balance</b>	
Basic Weighing Function .....	37
Calibration/Adjustment .....	40
Application Programs	
Toggle between	
Two Weight Units .....	48
Counting .....	50
Weighing in Percent .....	53
Animal Weighing .....	57
Recalculation .....	61
Calculation .....	66
Density Determination .....	69
Checkweighing .....	78
Time-controlled Functions .....	83
Totalizing .....	86
Formulation .....	90
Statistics .....	94
Additional Functions	
(App. Menu) .....	98
Second Tare Memory .....	98
Individual Identification Codes .....	100
Saving Values Manually .....	104
Product Data Memory .....	105
Basic Settings .....	108
"FlexPrint" Printout Function .....	109
Additional Functions	
(Balance Menu) .....	111
Combining Applications .....	113
Examples of Application	
Combinations .....	114
Data Output Functions .....	120
Pin Assignment Chart .....	133
MP8 Interface Emulation .....	135
<b>Error Codes and Messages</b> .....	136
<b>Care and Maintenance</b> .....	138
<b>Instructions for Recycling</b> .....	139
<b>Overview</b>	
General Views .....	140
Description of the Keys .....	144
Specifications .....	145
Accessories (Options) .....	154
Declaration of Conformity .....	156
EC Type Approval .....	159
Plates and Markings .....	162
Index .....	163

## Appendix

Entering the User Password

## Safety Precautions

This balance has been constructed in accordance with the European Directives as well as international regulations and standards for operation of electrical equipment, electromagnetic compatibility, and stipulated safety requirements. Improper use or handling, however, can result in damage and/or injury.

Read these operating instructions thoroughly before using your balance to prevent damage to the equipment. Keep these instructions in a safe place.

Follow the instructions below to ensure safe and trouble-free operation of your balance:

- ▲ Do not use this balance in a hazardous area/location
- ▲ Make sure that the voltage rating printed on the AC adapter is identical to your local line voltage
  - The only way to switch the power off completely is to disconnect the AC adapter
  - Type of protection for the housing:
    - Balances with a readability  $\leq 0.1$  mg comply with IP42
    - LA64001S, LA34001S, LA16001S, LA34001P and LA34000 meet IP44 requirements
    - Additional balances with a readability  $\geq 1$  mg comply with IP54
    - AC adapters meet IP20 requirements
  - Protect the AC adapter from contact with liquid.
  - Connect only Sartorius accessories and options, as these are optimally designed for use with your Master<sup>pro</sup> balance.

When cleaning your balance, make sure that no liquid enters the balance housing; use only a slightly moistened cloth to clean the balance.

Do not open the balance housing. If the seal is broken, this will result in forfeiture of all claims under the manufacturer's warranty.

In case you have any problems with your balance:

- contact your local Sartorius office, dealer or service center

## Operating Design

The balances in the Master<sup>pro</sup> Series consist of a weighing cell and a display and control unit. In addition to the choice of power supply (via AC adapter or external rechargeable battery pack), your balance also has an interface port for connecting a printer, computer or universal remote control switch.

The display and control unit and the weighing cell can be set up separately. Operation of Master<sup>pro</sup> balances follows a uniform "philosophy" which is described in this manual.

Where not expressly indicated otherwise, the uses described in this manual apply to verified and verifiable balance versions (indicated by the suffix "-OCE" in the model number), as well as the standard version.

### Combination of Several Applications

You can combine the use of various application programs to meet your more complicated requirements.

To select application programs one after the other, press  (toggle function).

## Keys

Your Master<sup>pro</sup> balance is operated either by using the keys on the display and control unit or via a connected PC. Operation by means of the balance keys is described in the following.

### Function Keys (Soft Keys)

The current function of a soft key is indicated in the bottom line of the display. In the example shown below,

- <<: Exit the setup menu
- Confis: Printout
- App: Application menu
- Info: Balance data
- Menu: Balance operating menu
- Input: Input all user data



The function keys are numbered F1 through F6, from right to left.

### Labeled Keys

These keys always have the function indicated, but are not available at all times. Availability of these functions depends on the current operating status and menu settings.

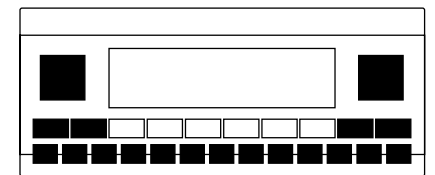

## Display

There are two fundamentally different types of display:

- display of measured and calculated values
- display for menu parameter settings (setup)

### Display of Measured and Calculated Values

This display is divided into nine sections.

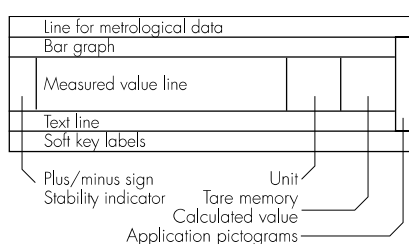

#### Line for Metrological Data:

When used in legal metrology, the following metrological specifications are shown here:

- Max** Maximum capacity of the balance
- Min** Minimum capacity of the balance; i.e., the minimum weight allowed when the balance is used in legal metrology
- e** Verification scale interval of the balance
- d** Readability: indicates the scale interval of the balance

On standard balances, only **Max** and **d** are shown.

#### Bar Graph:

The bar graph indicates how much of the balance's capacity is "used up" by the current load; during checkweighing, it indicates the control limits.

The following symbols may be displayed here:

- 0%** Lower load limit
- 100%** Upper load limit
- Bar graph showing 10% intervals
- Minimum for checkweighing
- = Target for checkweighing
- + Maximum for checkweighing

#### Plus/Minus Sign, Stability Symbol:

A plus or minus sign (+ or -) is shown here for a weight value (e.g., a calculated value when weighing in percent) or the symbol, indicating that the verified or verifiable balance has been zeroed or tared.

#### Measured Value Line:

This section shows the weighed or calculated value or alphanumeric input.

Note Concerning Verified Balances Approved for Use as Legal Measuring Instruments in the EU\*:

For verified balances that have a verification scale interval **e** which is greater than the scale interval **d**, the last digit on the display is bordered.

#### Unit and Stability:

When the balance reaches stability, the weight unit or calculation unit is displayed here.

When the symbol is displayed here, the value indicated in the readout cannot be used in legal metrology.

#### Tare Memory, Calculated Values:

The symbols displayed here indicate when there is a value in one of the tare memory modules or when the value shown is a result of calculation rather than direct measurement.

These symbols are as follows:

- Calculated value
- NET1** Tare memory used by an application program (e.g., formulation, second tare)
- NET2**

#### Application Pictograms:

The pictograms displayed here indicate the application(s) selected. The pictogram is displayed inversely when the corresponding application is active.

For example, the following symbols may be displayed simultaneously:

- The counting application is active
- Checkweighing is also active
- Print
- Data record

#### Text Line:

Additional information is displayed here (e.g., operator guidance prompts, name of the active program, etc.)

#### Soft Key Labels:

The current functions of the soft keys are indicated here; during calibration/adjustment, this line shows up- and down-arrows ( and ) for selecting calibration and adjustment functions.

\* including the Signatories of the Agreement on the European Economic Area

## Display for Menu Parameter Settings (Setup)

This display is divided into three sections.

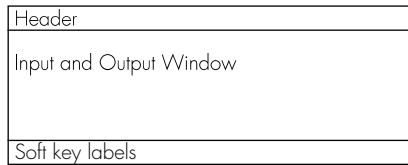

### Header

The header indicates the function of the current screen page. In the Setup program, the current menu path is shown here.

Example in the Path "Setup/Menu":

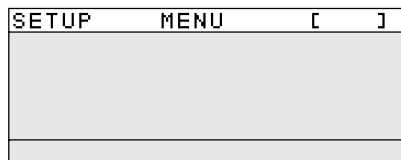

### Input and Output Window

This window contains either detailed information (e.g., on the active application) or a pick list. A selected item is displayed inversely. You can also enter information in an active field in this window using the alphanumeric keys.

Example in the Path "Setup/Menu":

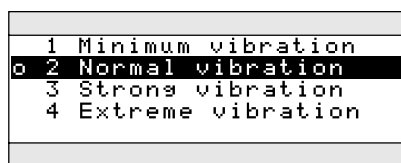

The **o** symbol in this window indicates the current menu setting.

## Soft Key Labels

The labels are symbols and/or abbreviations to indicate soft key functions. The abbreviations are usually self-explanatory.

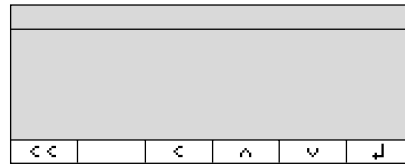

The arrows indicate the following functions:

- << Return to Setup menu (in the Setup menu: save settings and exit the Setup program)
- < Go back to the higher selection level
- > Show sub-items under the active item
- ^ Move upward in the input/output window
- v Move downward in the input/output window
- ↓ Set the selected menu parameter

## Input

### Numeric Input

To enter numbers: Press the **[1]** **[2]** ... **[0]** **[.]** keys

To store numbers entered: Press the corresponding soft key (i.e., the arrow key under the appropriate abbreviation in the bottom line of the display)

To interrupt/cancel numeric input: Press **[CF]**

### Alphabetic Input

(see also the example given on page 39)

- To enter letters or characters: first press the **[ABC]** key
- > Letters are displayed in the bottom line
- To select a different letter: press the corresponding soft key to change the letter shown (i.e., the arrow key under the letter displayed)
- To select the letter/character shown: press the corresponding soft key
- > The selected letter is shown in the display
- Enter the next letter/character, if desired, as above.
- To store a word: press the corresponding soft key (e.g., **[S ID]**)
- To delete a word: press **[CF]**

### Parameter Settings

The parameters for configuration are in the application menu and the balance operating menu. These menus have several levels.

- To set parameters: press **[SETUP]** and then the appropriate soft key (e.g., **[APP]** for the application menu)
- To move within a menu level: use the **^** and **v** soft keys

To select a parameter:

- Press  $\blacktriangle$  or  $\blacktriangledown$  repeatedly until the desired setting is selected (displayed inversely)
- Confirm your selection by pressing the  $\blacktriangledown$  soft key

To change the numeric value of a parameter:

- Press  $\blacktriangle$  or  $\blacktriangledown$  repeatedly until the desired setting is selected (displayed inversely)
- Enter the desired number using the  $\boxed{1}$   $\boxed{2}$  ...  $\boxed{0}$   $\boxed{\cdot}$  keys
- Confirm your selection by pressing the  $\blacktriangledown$  soft key

To return to the Setup/Select level:

- Press the  $\blacktriangleleft$   $\blacktriangleleft$  soft key

See the chapter entitled "Configuring the Balance" for a complete description of all parameters.

To save the parameter settings and exit the Setup menu: press the  $\blacktriangleleft$   $\blacktriangleleft$  soft key

To cancel the parameter setting operation: press  $\boxed{1/0}$

## Data Output

Your Master<sup>PRO</sup> balance is equipped with an interface port for connecting your choice of the following:

- Printer
- Peripheral device (e.g., computer)
- Universal remote control switch

### Printer

You can configure the print functions to meet your individual requirements by selecting the corresponding menu code.

You can have printouts generated automatically, or by pressing  $\boxed{\text{Q}}$ ; dependent on or independent of the stability or time parameters; with or without IDs; and as standard or ISO/GLP-compliant printouts.

ISO: International Organization for Standardization

GLP: Good Laboratory Practice

See the section on "Data Output Functions" in the chapter entitled "Operating the Balance" for a detailed description of data output options.

### Interface Port

Instead of a printer, you may choose to connect a different peripheral device, e.g. a computer (PC). With an on-line PC you can control both the weighing cell and the display unit of the Master<sup>PRO</sup> balance.

Request messages are sent via the interface to initiate functions in the weighing cell and in the display unit. Some of the functions generate response messages.

See the chapter entitled "Operating the Balance" under the section on "Data Output" for a detailed description of the interface port.

## Error Codes

If you press a key that has no function, or which is blocked at a certain point in an application program, this error is indicated as follows:

- a double-beep is sounded as an acoustic signal if the key has no function
- a double-beep is sounded and a message is displayed for 2 seconds in the text line if the key function is not available at that time

The response to an operator error is identical in all models of the Master<sup>PRO</sup> series. See the chapter entitled "Error Codes" for a detailed description.

## Storing Settings

### Storing Parameter Settings

The settings configured are stored in the balance's non-volatile memory. The most recent parameter settings are active when you switch on the balance.

### Saving Parameter Settings

You can assign passwords in order to block access to:

- printing function **Confis**
- the application menu **App**
- the balance operating menu **Menu** and
- user data input functions **Input**

## Getting Started

### Storage and Shipping Conditions

Allowable storage temperature:  
+0 °C ...+40 °C (+32°F ...+104°F)

The packaging has been designed to ensure that the balance will not be damaged even if it is dropped from a height of 80 centimeters (about 31 inches).

### Unpacking the Balance

- After unpacking the balance, check it immediately for any visible damage as a result of rough handling during shipment.
- If this is the case, proceed as directed in the chapter entitled "Care and Maintenance," under the section on "Safety Inspection."

It is a good idea to save the box and all parts of the packaging until you have successfully installed your balance. Only the original packaging provides the best protection for shipment. Before packing your balance, unplug all connected cables to prevent damage. The strip of cardboard between the display and control unit and the weighing platform is important for protecting the equipment during shipment!

#### Important Note Concerning Verified Balances Approved for Use as Legal Measuring Instruments in the EU\*:

Provided that an official seal is required for the verified balance, a control seal is affixed to the balance. This seal will be irreparably damaged if you attempt to remove it. If the seal is broken, the validity of the verification will become void and you must have your balance re-verified.

\* including the Signatories of the Agreement on the European Economic Area

### Warranty

Do not miss out on the benefits of our full warranty. Complete the warranty registration card, indicating the date of installation, and return the card to your Sartorius office or dealer.

### Equipment Supplied

The equipment supplied includes the components listed below:

#### LA balances with a readability of 0.1 mg

- Balance with display and control unit
- AC adapter
- Dust cover
- Bushing
- Shield plate
- Shield disk
- Weighing pan

#### LA balances with a readability of 1 mg

- Balance with display and control unit
- AC adapter
- Dust cover
- Shield disk
- Pan support
- Weighing pan
- Glass draft shield cylinder
- Draft shield cover

#### LA8200S, LA8200P, LA 6200S, LA 4200S, LA 2200S, LA 820, LA 420, LA 2200P, LA 5200P

- Balance with display and control unit
- AC adapter
- Dust cover
- Pan draft shield
- Weighing pan

#### LA 12000S, LA 6200, LA 4200, LA 2200, LA 12000P

- Balance with display and control unit
- AC adapter
- Dust cover
- Weighing pan

#### LA balances with a capacity $\geq 16$ kg

- Balance with display and control unit
- AC adapter
- Dust cover
- Weighing pan
- Dust cover for the display and control unit

### Installation Instructions

The Sartorius Master<sup>PRO</sup> balances are designed to provide reliable weighing results under normal ambient conditions in the laboratory and in industry. When choosing a location to set up your balance, observe the following so that you will be able to work with added speed and accuracy:

- Set up the balance on a stable, even surface
- Avoid placing the balance in close proximity to a heater or otherwise exposing the balance to heat or direct sunlight
- Protect the balance from drafts that come from open windows or doors
- Avoid exposing the balance to extreme vibrations during weighing
- Protect the balance from aggressive chemical vapors
- Do not expose the balance to extreme moisture over long periods

### Conditioning the Balance

Moisture in the air can condense on the surfaces of a cold balance whenever it is brought into a substantially warmer place. If you transfer the balance to a warmer area, make sure to condition it for about 2 hours at room temperature, leaving it unplugged from AC power. Afterwards, if you keep the balance connected to AC power, the continuous positive difference in temperature between the inside of the balance and the outside will practically rule out the effects of moisture condensation.

#### Monitoring Ambient Conditions When Using Verified Balances Approved for Use as Legal Measuring Instruments in the EU\*:

- For balances of accuracy class  $\text{I}$ , a thermometer and barometer are recommended for monitoring ambient conditions.

## Setting up the Balance

### Preparing Balances with Analytical Draft Shield Chambers

- Place the components listed below on the balance in the order given:
  - Bushing (pan adapter)
  - Shield plate
  - Shield disk
  - Weighing pan

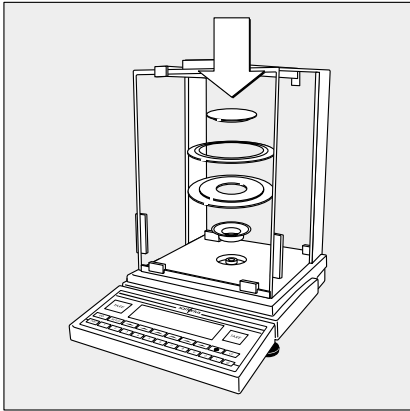

### Preparing Balances with a Round Glass Draft Shield

- Place the components listed below on the balance in the order given:
  - Dust cover
  - Protective disk; turn counter-clockwise until it stops and is secure
  - Pan support
  - Weighing pan
  - Glass draft shield cylinder
  - Draft shield cover

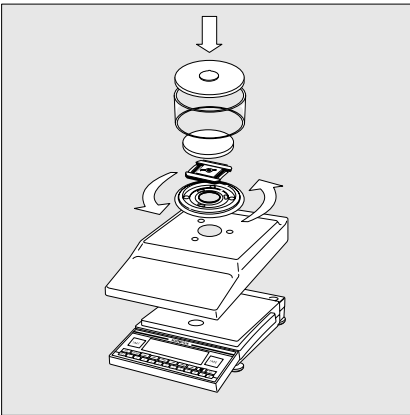

### Preparing Balances with a Rectangular Weighing Pan and a Weighing Capacity $\leq 12$ kg

- Place the components listed below on the balance in the order given:
  - Dust cover
  - Weighing pan draft shield (only for balances with a readability of 0.01 g)
  - Weighing pan

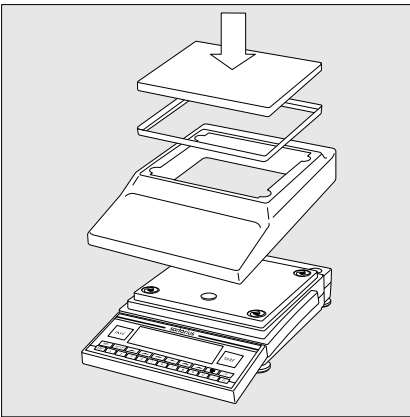

### Preparing Balances with a Rectangular Weighing Pan and a Weighing Capacity $\geq 16$ kg

- Place the weighing pan on the balance

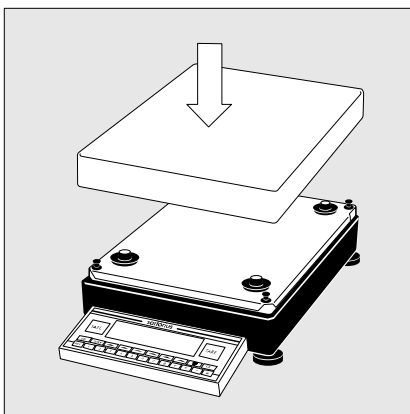

## Separate Operation of the Display Unit

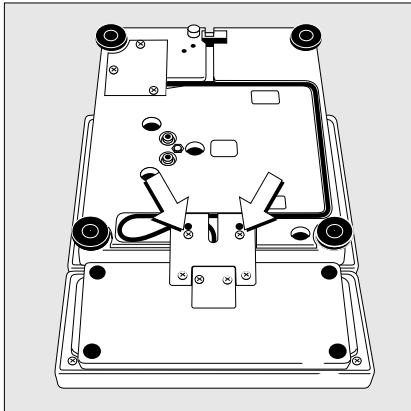

- Turn the balance on its side and lay it on a padded surface to avoid damage to the weighing system
- Use a screwdriver to remove the 2 screws from the display unit retainer
- Remove the display unit
- > Cable lengths
  - LA balances with a weighing capacity  $\leq 12$  kg: 55 cm
  - LA balances with a weighing capacity  $> 12$  kg: 80 cm
- See the chapter entitled “Accessories” for information on longer cables
- If you wish to use a longer cable, it must be installed by an authorized Sartorius service technician

## Options for Mounting the Display Unit for LA Balances with a Weighing Capacity $\geq 16$ kg

The display unit can be mounted as follows:

- on the short side of the weighing cell (factory mounting)
- on the back (long side) of the weighing cell

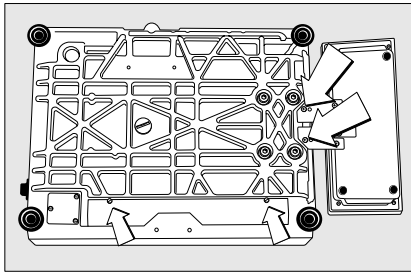

- Turn the weighing cell over
- Remove the fastening screws from the display unit retainer
- Remove the fastening screws from the plate that covers the cable raceway (channel) and remove the plate

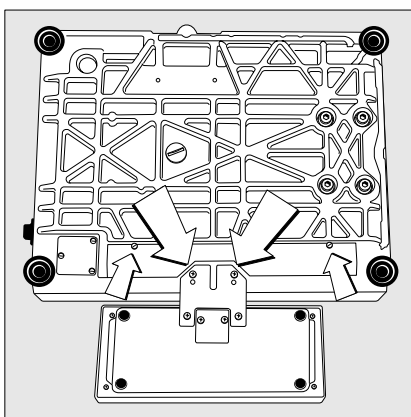

- Fasten the display retainer onto the back of the weighing cell with the 2 Allen screws
- Thread the cable through the raceway and replace the cover plate

## Connecting the Balance to AC Power

- Check the voltage rating and the plug design
  - If they do not match the rating or standard you use, contact your Sartorius office or dealer

Use only

- Original Sartorius AC adapters
- AC adapters with a registered approval rating from a national testing laboratory
- To use a main feeder cable from the ceiling or to mount a CEE plug, you will have to make arrangements
- See the chapter entitled "Accessories" for information on using an IP65-protected industrial AC adapter or an external rechargeable battery pack with your balance

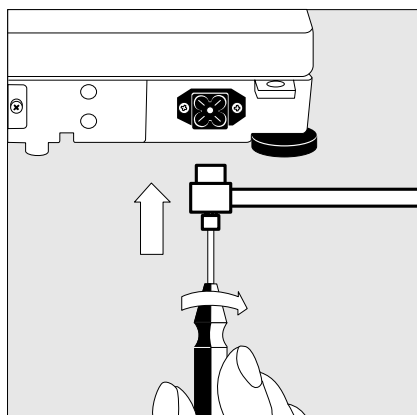

- Insert the right-angle plug into the jack and then tighten the screws
- Then insert the plug of the AC adapter into a wall outlet (mains)

### Safety Precautions

The AC adapter rated to Class 2 can be plugged into any wall outlet without requiring any additional safety precautions. The pole of the output voltage is connected to the balance housing, which can be grounded for operation. The data interface is also electrically connected to the balance housing (ground).

Note:

This equipment has been tested and found to comply with the limits for a Class A digital device, pursuant to Part 15 of the FCC rules. These limits are designed to provide reasonable protection against harmful interference when the equipment is operated in a commercial environment. This equipment generates, uses and can radiate radio frequency energy and, if not installed and used in accordance with the instruction manual, may cause harmful interference to radio communications. Operation of this equipment in a residential area is likely to cause harmful interference in which case the user will be required to correct the interference at his own expense. Changes or modifications not expressly approved by Sartorius AG could void the user's authority to operate the equipment.

### Connecting Electronic Peripheral Devices

- Make absolutely sure to unplug the balance from AC power before you connect or disconnect a peripheral device (printer or PC) to or from the interface port.

### Warmup Time

To deliver exact results, the balance must warm up for at least 30 minutes after initial connection to AC power. Only after this time will the balance have reached the required operating temperature.

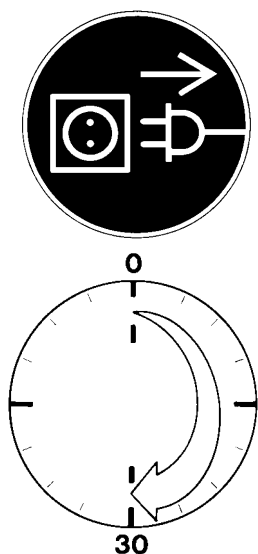

Using Verified Balances Approved for Use as Legal Measuring Instruments in the EU\*:

- The balance must warm up for at least 24 hours after initial connection to AC power or after a relatively long power outage.
- For balances with a readability of  $\leq 0.1$  mg:  
wait until the automatic calibration/adjustment routine has ended.

\* including the Signatories of the Agreement on the European Economic Area

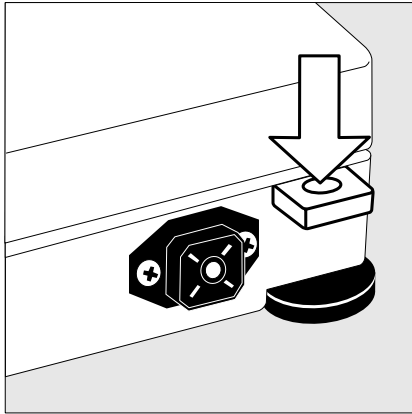

## Fastening an Antitheft Locking Device: Balances with a Weighing Capacity $\leq 12$ kg

To fasten an antitheft locking device, use the lug located on the rear panel of the balance.

- Secure the balance at the place of installation, e.g., with a chain or a lock.

## Leveling the Balance

Purpose:

- To compensate for unevenness at the place of installation
- To achieve perfectly horizontal positioning of the balance for consistent reproducibility

Always level the balance again any time it is moved

### Leveling Balances with a Weighing Capacity $\leq 12$ kg

Only the 2 front feet are used for leveling.

- Retract the 2 rear feet (only for models with rectangular weighing pan)
  - Turn the 2 front feet as shown in the illustration until the air bubble is centered within the circle of the level indicator
- > Several leveling steps are usually required.
- When weighing heavy samples (or when the YDH 01 LP display arm is attached):  
Extend the 2 rear feet until they touch the surface on which the balance rests

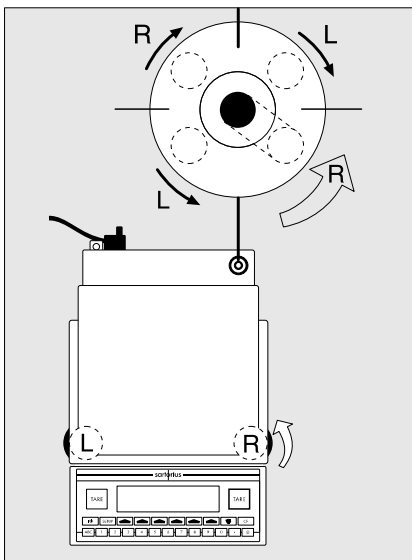

### Leveling Balances with a Weighing Capacity $\geq 16$ kg

- Adjust the four leveling feet until the air bubble is centered within the circle of the level indicator

## Setting the Language

- > See the "Setting the Language" section in the chapter entitled "Configuring the Balance"

## Setting the Date and Time

- > See the "Entering User Data" section in the chapter entitled "Configuring the Balance"

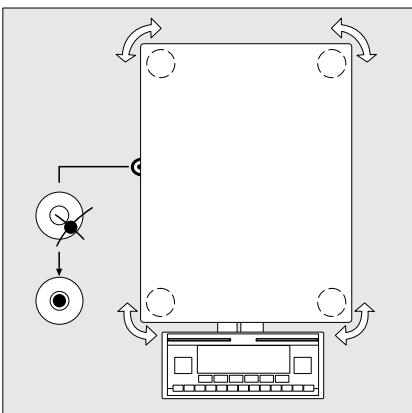

## Configuring the Balance

### Purpose

You can configure your Master<sup>PRO</sup> balance to meet individual requirements by entering user data and setting parameters in the Setup menu.

The Setup menu is divided into three functions: the application menu, balance data and user data input.

You can also configure the display to show specific information about the balance (serial no., etc.).

### Configuring the Balance for Use in Legal Metrology

Set the switch as described below to configure the following functions for use of the balance in legal metrology:

- Display: Verification scale interval: **e**;  
lower limit of the weighing capacity: **Min**
- External calibration blocked
- MP8-interface emulation blocked
- Remove the covering plate from the back of the balance housing
- Move Switch 1 in the direction of the arrow

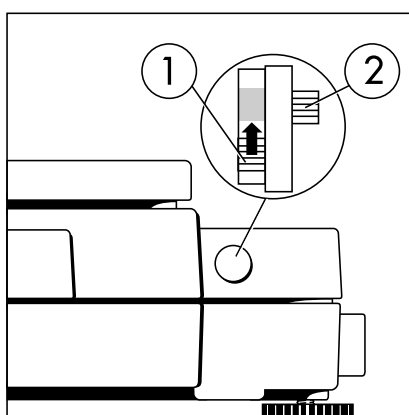

- > Switch up: external calibration blocked (factory setting on verified balances)  
Switch down: external calibration accessible
- > Note:  
Do not move Switch 2

## Setting the Language

### Features

You can choose from 5 languages for the information display:

- 1 German
- 2 English (factory setting)
- 3 English with US date/time format
- 4 French
- 5 Italian
- 6 Spanish

### Selecting the Language

- Enter the corresponding number
- Press **SETUP**
- Exit the Setup menu:  
Press the **◀** soft key

## Entering User Data (Input)

### Purpose

To display, input or change user data. You can block access to these data by assigning a password.

### Features

You can display, input or change the following user data:

- Workstation number for the balance: ID (balance ID; max. 20 characters)\*
- Weighing series number, to designate a series or lot: L ID (Lot ID; max. 20 characters)\*
- Weight set number for calibration/adjustment: W ID (weight ID; max. 14 characters)\*
- Exact calibration weight value for calibration/adjustment of the balance, e.g. for adjustment according to a DKD certificate (see the section on "Calibration/Adjustment" in the chapter entitled "Operating the Balance")
- Time (hh.mm.ss; hh can be entered without a preceding zero)

- Date (dd.mm.yy, or mm.dd.yy when you select "English with US date/time" as the language)
- Contrast/angle of the display (enter a number from 0 to 4; factory setting: 2)
- Password for access to the Setup menu, which contains the Input, Application and Balance Menu functions (max. 8 characters)\*
- ID codes (20 characters max.): the factory-set designations for these codes are ID1, ID2, ID3 and ID4\*  
The ID codes are left-justified on the printout.
- Three calibration/adjustment times (hh.mm; hh can be entered without a preceding zero)  
Calibration/adjustment is repeated every day at the selected time settings (up to 3 maximum: for example, at 7:30, 12:00 and 18:15)

\*: If the last character of user data is a letter: conclude input by pressing **ABC**

To delete user data: Enter a **.** (decimal point) or a space and confirm

To delete the last character entered: Press **CF** (see the section on "Basic Settings" in the chapter entitled "Operating the Balance")

## Factory Settings

Password: No designation

If no password has been assigned, anyone can access the Setup:Input, Setup:App and Setup:Menu functions without entering a password.

If you assign a password and then forget what the word is, you can use the User Password (see Appendix) to access these menus.

## Preparation

Display existing user data

- Select the Setup program:  
Press **SETUP**
- > "SETUP SELECTION" is displayed.

SETUP	SELECTION
Config =>	Printout configuration
App =>	Application menu
Info =>	Balance parameters
Menu =>	Balance menu
Input =>	User data
<<	Config App Info Menu Input

- Select User Data:  
Press the **Input** soft key  
If you have already assigned a password:  
> The password prompt is displayed
- If access is blocked by a password: enter the password using the alphanumeric keys
- If the last character of the password is a letter: conclude input by pressing **ABC**
- Press **↓** to confirm the password  
> User data is displayed:

SETUP	INPUT
Identific. (ID):	12345678901234567890
Lot (CL ID):	
Wt. ID (W ID):	WT.23 "F1"
Cal./adj. wt.:	2000.00 g
Time:	10.34.10
<<	v ↓

## Enter/Change Password

- Select the Setup program:  
Press **SETUP**
- > **SETUP SELECTION** is displayed
- Select Information:  
Press the **Input** soft key  
If you have already assigned a password:  
> The password prompt is displayed

SETUP	PASSM.CHECK
Enter password:	██████████
<<	↓

- Enter the password
- Press **↓** to confirm the password  
> User data is displayed:
- Write down the password here for easy reference:  
Password = .....
- If you assign a password and then forget what the word is:
- Enter the User Password (see Appendix)
- Press **↓** to confirm the password  
> User data is displayed:
- Select the password-setting function:  
Press the **v** soft key repeatedly until  
> **Enter password:** and any existing password are displayed
- New password: Enter the letters/numbers for the new password (max. 8 characters)\*  
If "none" is displayed as the password, this means no password has been assigned  
To delete the password:  
Enter **·** and confirm
- To confirm:  
press the **↓** soft key
- Exit the Setup menu:  
Press the **<<** soft key  
> Restart the application

## Practical Example 1:

Enter "Workstation 234" as Balance ID; display and print other User data

Step	Key (or instruction)	Display/Output
1. Select Setup:Input Display workstation ID (in this example: no ID assigned)	Press <b>SETUP</b> , then the <b>Input</b> soft key	<pre> SETUP      INPUT Identific. (ID): Lot      (L ID):      LOT 23 Wt. ID   (W ID):      WEIGHT 23"F1" Cal./adj. wt.:      2000.00 g Time:      09.00.26           &lt;&lt;          v          ↓         </pre>
2. Before entering letters –	Press <b>ABC</b>	<pre> SETUP      INPUT Identific. (ID): Lot      (L ID):      LOT 23 Wt. ID   (W ID):      WEIGHT 23"F1" Cal./adj. wt.:      2000.00 g Time:      09.00.26 ABCDEF GHIJKL MNOPQR STUWVX YZ/=-? :##"&amp;          </pre>
3. Select the letters group	Press the <b>STUWVX</b> soft key	<pre> SETUP      INPUT Identific. (ID): Lot      (L ID):      LOT 23 Wt. ID   (W ID):      WEIGHT 23"F1" Cal./adj. wt.:      2000.00 g Time:      09.00.26           S          T          U          V          W          X         </pre>
4. Set the letter "W"	Press the <b>W</b> soft key	<pre> SETUP      INPUT Identific. (ID): Lot      (L ID):      LOT 23 Wt. ID   (W ID):      WEIGHT 23"F1" Cal./adj. wt.:      2000.00 g Time:      09.00.26 ABCDEF GHIJKL MNOPQR STUWVX YZ/=-? :##"&amp;          </pre>
5. Enter the next letters of the – balance ID	Press the <b>MNOPQR</b> soft key	<pre> SETUP      INPUT Identific. (ID): Lot      (L ID):      LOT 23 Wt. ID   (W ID):      WEIGHT 23"F1" Cal./adj. wt.:      2000.00 g Time:      09.00.26           M          N          O          P          Q          R         </pre>
6. Set the letter "O"	Press the <b>O</b> soft key	<pre> SETUP      INPUT Identific. (ID): Lot      (L ID):      LOT 23 Wt. ID   (W ID):      WEIGHT 23"F1" Cal./adj. wt.:      2000.00 g Time:      09.00.26 ABCDEF GHIJKL MNOPQR STUWVX YZ/=-? :##"&amp;          </pre>
7. Repeat steps 5 and 6 to enter the required letters	Soft key ...	
8. Enter the numbers 234	<b>2</b> <b>3</b> <b>4</b>	<pre> SETUP      INPUT Identific. (ID):      WORKSTATION 234 Lot      (L ID):      LOT 23 Wt. ID   (W ID):      WEIGHT 23"F1" Cal./adj. wt.:      2000.00 g Time:      09.00.26           &lt;&lt;          v          ↓         </pre>
If the last character entered is a letter: Conclude input of letters	<b>ABC</b>	
9. Store balance ID	Press the <b>↓</b> soft key	<pre> SETUP      INPUT Identific. (ID):      WORKSTATION 234 Lot      (L ID):      LOT 23 Wt. ID   (W ID):      WEIGHT 23"F1" Cal./adj. wt.:      2000.00 g Time:      09.00.26           &lt;&lt;          v          ↓         </pre>

Step	Key (or instruction)	Display/Output														
10. Display other user data - Lot number - Weight set ID - Calibration weight - Time - Date - Display contrast - Password - ID code - Three calibration/ adjustment times	Press the $\nabla$ soft key repeatedly	<table border="1"> <thead> <tr> <th>SETUP</th> <th>INPUT</th> </tr> </thead> <tbody> <tr> <td>Cal./adj. wt.:</td> <td>2000.02 g</td> </tr> <tr> <td>Time:</td> <td>18.47.41</td> </tr> <tr> <td>Date:</td> <td>13.03.97</td> </tr> <tr> <td>Contrast(0-4):</td> <td>2</td> </tr> <tr> <td>Password:</td> <td>██████████</td> </tr> <tr> <td>&lt;&lt;</td> <td>↵</td> </tr> </tbody> </table>	SETUP	INPUT	Cal./adj. wt.:	2000.02 g	Time:	18.47.41	Date:	13.03.97	Contrast(0-4):	2	Password:	██████████	<<	↵
SETUP	INPUT															
Cal./adj. wt.:	2000.02 g															
Time:	18.47.41															
Date:	13.03.97															
Contrast(0-4):	2															
Password:	██████████															
<<	↵															
11. Print user data (example)		<table border="1"> <tbody> <tr> <td>ID</td> <td>WORKSTATION</td> <td>234</td> </tr> <tr> <td>L ID</td> <td></td> <td>LOT 23</td> </tr> <tr> <td>W ID</td> <td>WEIGHT</td> <td>23"F1"</td> </tr> <tr> <td>Cal. wt.</td> <td></td> <td>+2000.00</td> </tr> </tbody> </table>	ID	WORKSTATION	234	L ID		LOT 23	W ID	WEIGHT	23"F1"	Cal. wt.		+2000.00		
ID	WORKSTATION	234														
L ID		LOT 23														
W ID	WEIGHT	23"F1"														
Cal. wt.		+2000.00														
12. Exit Setup:Input	Press the << soft key															

## Practical Example 2:

Setting the date and time

Step	Key (or instruction)	Display/Output										
1. Select Setup:Input Display workstation ID	Press <b>SETUP</b> , then the <b>Input</b> soft key	<pre> SETUP      INPUT Identific. (ID): ██████████ Lot      (L ID): Wt. ID   (W ID): Cal./adj. wt.:      2000.00 g Time:                00.04.03 &lt;&lt;   </pre>										
2. Select the time	Press the <b>v</b> soft key repeatedly	<pre> SETUP      INPUT Identific. (ID): ██████████ Lot      (L ID): Wt. ID   (W ID): Cal./adj. wt.:      2000.00 g Time:                00.01.10 &lt;&lt;   </pre>										
3. Enter the time	<table border="1" style="display: inline-table; vertical-align: middle;"> <tr><td>1</td><td>1</td><td>.</td><td>1</td><td>2</td></tr> <tr><td>.</td><td>3</td><td>0</td><td></td><td></td></tr> </table>	1	1	.	1	2	.	3	0			<pre> SETUP      INPUT Identific. (ID): ██████████ Lot      (L ID): Wt. ID   (W ID): Cal./adj. wt.:      2000.00 g Time:                11.12.30 &lt;&lt;   </pre>
1	1	.	1	2								
.	3	0										
4. Set the selected time and restart the clock. The date is selected automatically.	Press the <b>↓</b> soft key	<pre> SETUP      INPUT Lot      (L ID): Wt. ID   (W ID): Cal./adj. wt.:      2000.00 g Time:                11.12.30 Date:                01.01.97 &lt;&lt;   </pre>										
5. Enter the date	<table border="1" style="display: inline-table; vertical-align: middle;"> <tr><td>1</td><td>3</td><td>.</td><td>0</td><td>3</td></tr> <tr><td>.</td><td>9</td><td>7</td><td></td><td></td></tr> </table>	1	3	.	0	3	.	9	7			<pre> SETUP      INPUT Lot      (L ID): Wt. ID   (W ID): Cal./adj. wt.:      2000.00 g Time:                11.13.46 Date:                13.03.97 &lt;&lt;   </pre>
1	3	.	0	3								
.	9	7										
6. Store the date	Press the <b>↓</b> soft key	<pre> SETUP      INPUT Lot      (L ID): Wt. ID   (W ID): Cal./adj. wt.:      2000.00 g Time:                11.13.46 Date:                13.03.97 &lt;&lt;   </pre>										
7. Display other user data – Lot number – Weight set ID – Calibration weight – Time – Date – Display contrast – Password – ID code – Three calibration/ adjustment times	Press the <b>v</b> or <b>^</b> soft key											
8. Exit Setup:Input	Press the <b>&lt;&lt;</b> soft key											

## Application Menu Settings (APP)

### Purpose

To configure the balance, i.e., adapt the balance to individual requirements by selecting from a list of parameter options in a menu. You can block access to this menu by assigning a password.

### Features

The simple weighing function is available at all times. You can select one from each of the following application groups. This means a number of combinations are possible.

#### Application 1

- Toggle between 2 weight units
- Counting
- Weighing in percent
- Animal weighing
- Recalculation
- Calculation
- Density determination

#### Application 2

- Checkweighing
- Time-controlled functions

#### Application 3

- Totalizing
- Formulation
- Statistics

In addition, you can assign 2 extra functions to each of the soft keys, in some cases (depends on the Setup configuration):

- 2nd tare memory
- Identification code
- Manual totalizing
- Product data memory

### Factory Settings

The factory-set configurations are marked with an "o" in the list starting on page 20.

### Preparation

- Select the Setup program:  
Press **SETUP**
- > **SETUP SELECTION** is displayed
- Select the application menu:  
Press the **APP** soft key
- If a password has been assigned:  
> The password prompt is displayed
- Enter the password
- Confirm the password entered:  
Press the **↓** soft key
- > The application menu is displayed (1st menu level):

SETUP	APPLICATION
Application 1	Toggle wt.units
Application 2	Counting
Application 3	Percent weigh.
Extra func. (F4)	Animal weigh.
Extra func. (F5)	Calculation
<< Menu	v

- Select the next group:  
Press the **↓** soft key (arrow down)
- To select the previous item in the group: press **↑** soft key (arrow up)
- To select one item lower in the group: Press the **→** soft key (arrow right)
- To return to the next level up: Press the **←** soft key (arrow left)
- Confirm the selected menu item:  
Press the **↓** soft key
- Move the highlight bar to the first menu item on the list: Press **CF**
- Toggle to the Setup:Balance menu (see also page 28):  
Press the **Menu** soft key

### Additional Functions

- Save settings and exit the application menu:  
Press the **←←** soft key
- > Restart the application
- Print parameter settings:
  - When the application menu is displayed: Press **☺**
  - > Printout (Example)

#### Application 1

```

-----
Toggle wt. units
Weight unit 1
Grams /g
Display accuracy 1
All digits
Weight unit 2
Grams /g
Display accuracy 2
All digits
    
```

#### Application 2

```

-----
Off
    
```

etc.

- To reset parameters to the factory settings: see the following chapter, entitled "Balance Operating Menu," and set menu code **9 1 1**

## Practical Example

Make every printout a ISO/GLP-compliant printout

Step	Key (or instruction)	Display/Output
1. Select Setup	<b>SETUP</b>	<pre> SETUP          SELECTION Config =&gt; Printout configuration App   =&gt; Application menu Info  =&gt; Balance parameters Menu  =&gt; Balance menu Input =&gt; User data &lt;&lt;  ConfigApp  Info  Menu  Input           </pre>
2. Select the application menu	Press the <b>APP</b> soft key	<pre> SETUP          APPLICATION Application 1 =&gt; Tossle wt.units Application 2      Countins Application 3      Percent weigh. Extra func. (F4)   Animal weigh. Extra func. (F5)   Calc., density &lt;&lt;  Menu        v        &gt;           </pre>
3. Menu level 1: Select Basic Settings	Press the <b>v</b> soft key repeatedly	<pre> SETUP          APPLICATION Application 2 =&gt; Keypad Application 3      Display Extra func. (F4)   Printout Extra func. (F5)   Auto-start app. Basic settings &lt;&lt;  Menu        ^        &gt;           </pre>
4. Confirm selection	Press the <b>➤</b> soft key	<pre> SETUP          APPLICATION BASIC SET. Keypad Display Printout configuration Auto-start app. when power goes on &lt;&lt;  Menu        &lt;        v        &gt;           </pre>
5. Menu level 2: Select Printout Configuration	Press the <b>v</b> soft key twice	<pre> SETUP          APPLICATION BASIC SET. Keypad Display Printout configuration Auto-start app. when power goes on &lt;&lt;  Menu        &lt;        ^        v        &gt;           </pre>
6. Confirm selection and go to menu level 3	Press the <b>➤</b> soft key	<pre> APPLICATION BASIC SET. PRINT CONF. Auto print upon initialization Line format ISO/GLP/GMP printout &lt;&lt;  Menu        &lt;        v        &gt;           </pre>
7. Menu level 3: Select "ISO/GLP/GMP Printout"	Press the <b>v</b> soft key twice	<pre> APPLICATION BASIC SET. PRINT CONF. Auto print upon initialization Line format ISO/GLP/GMP printout &lt;&lt;  Menu        &lt;        ^        &gt;           </pre>
8. Confirm selection and go to menu level 4	Press the <b>➤</b> soft key	<pre> BASIC SET. PRINT CONF. ISO/GLP/GMP Off Only for calibration/adjustment Always on &lt;&lt;  Menu        &lt;        v        ↓           </pre>

Step	Key (or instruction)	Display/Output
9. Menu level 4: Select "Always"	Press the $\nabla$ soft key twice	<pre> BASIC SET. PRINT CONF. ISO/GLP/GMP Off Only for calibration/adjustment Always on           </pre>
10. Confirm selection	Press the $\downarrow$ soft key	<pre> BASIC SET. PRINT CONF. ISO/GLP/GMP Off Only for calibration/adjustment Always on           </pre>
11. Set other menu codes, if desired	$\nabla \wedge$ soft key	
12. Confirm setting and exit Setup	Press the $\llcorner \llcorner$ soft key	

## Setup Parameters, "Application Menu" (Overview)

- Factory setting
- ✓ User setting

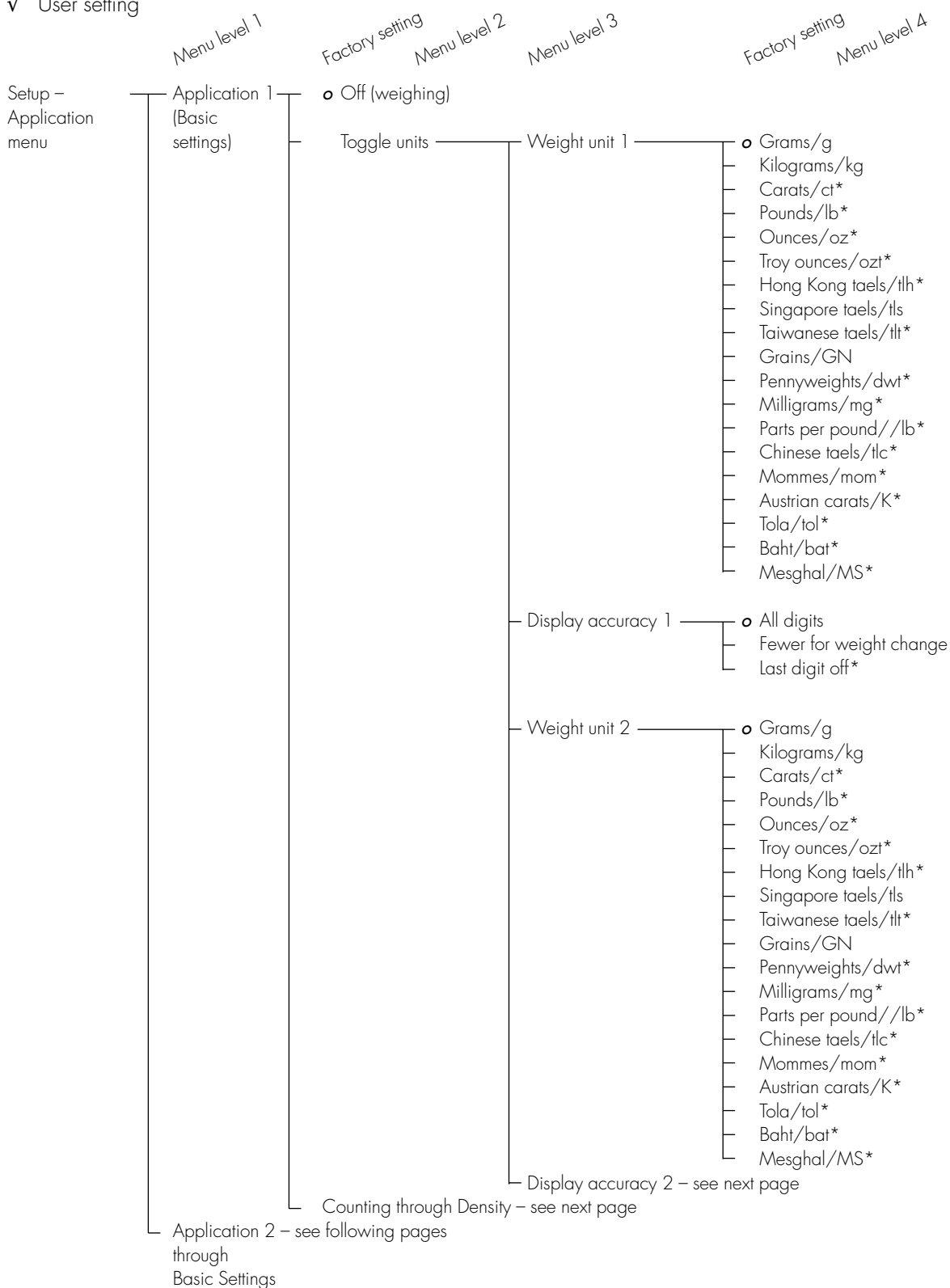

\* = not applicable to verified balances

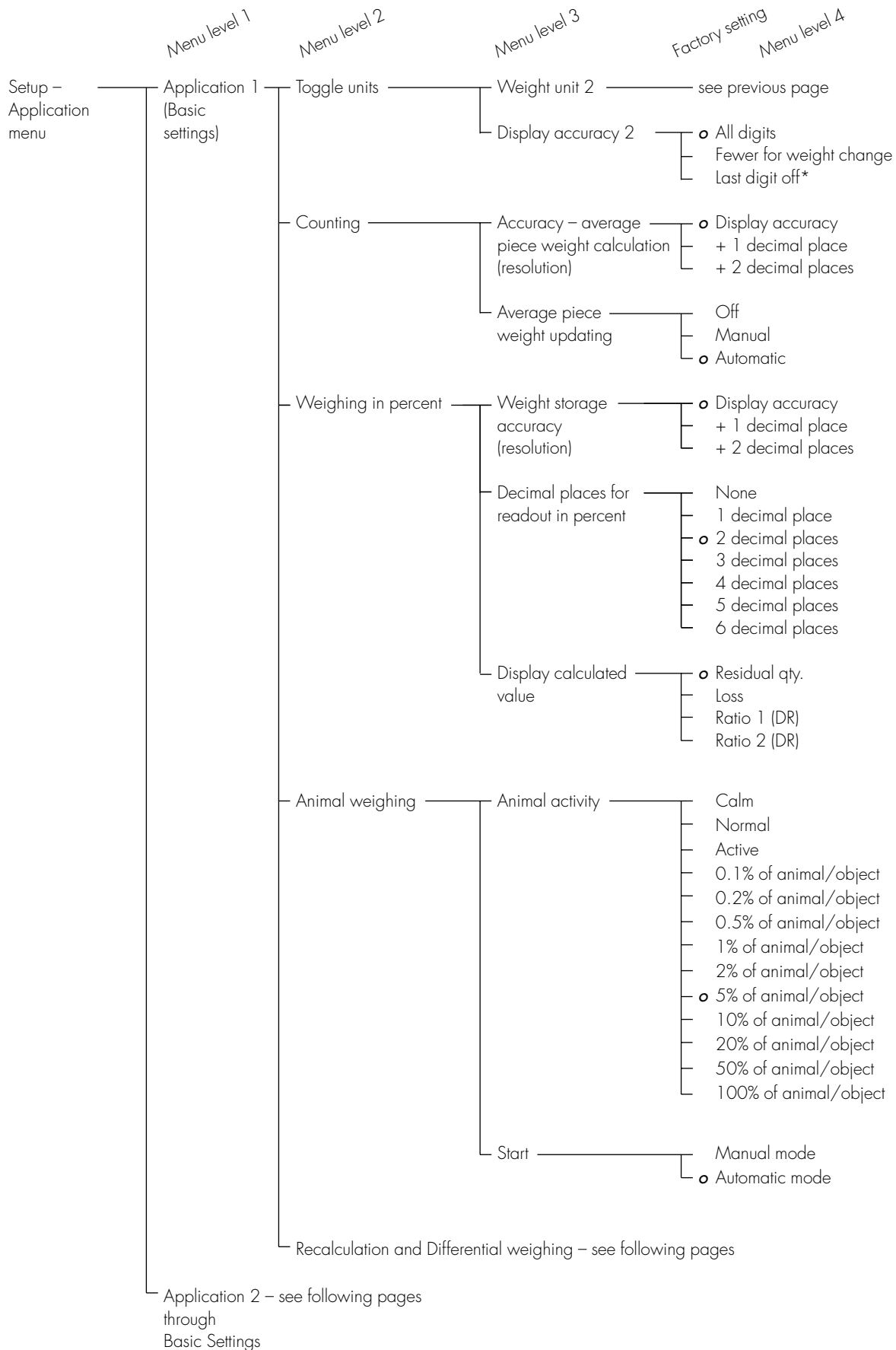

\* = not applicable to verified balances

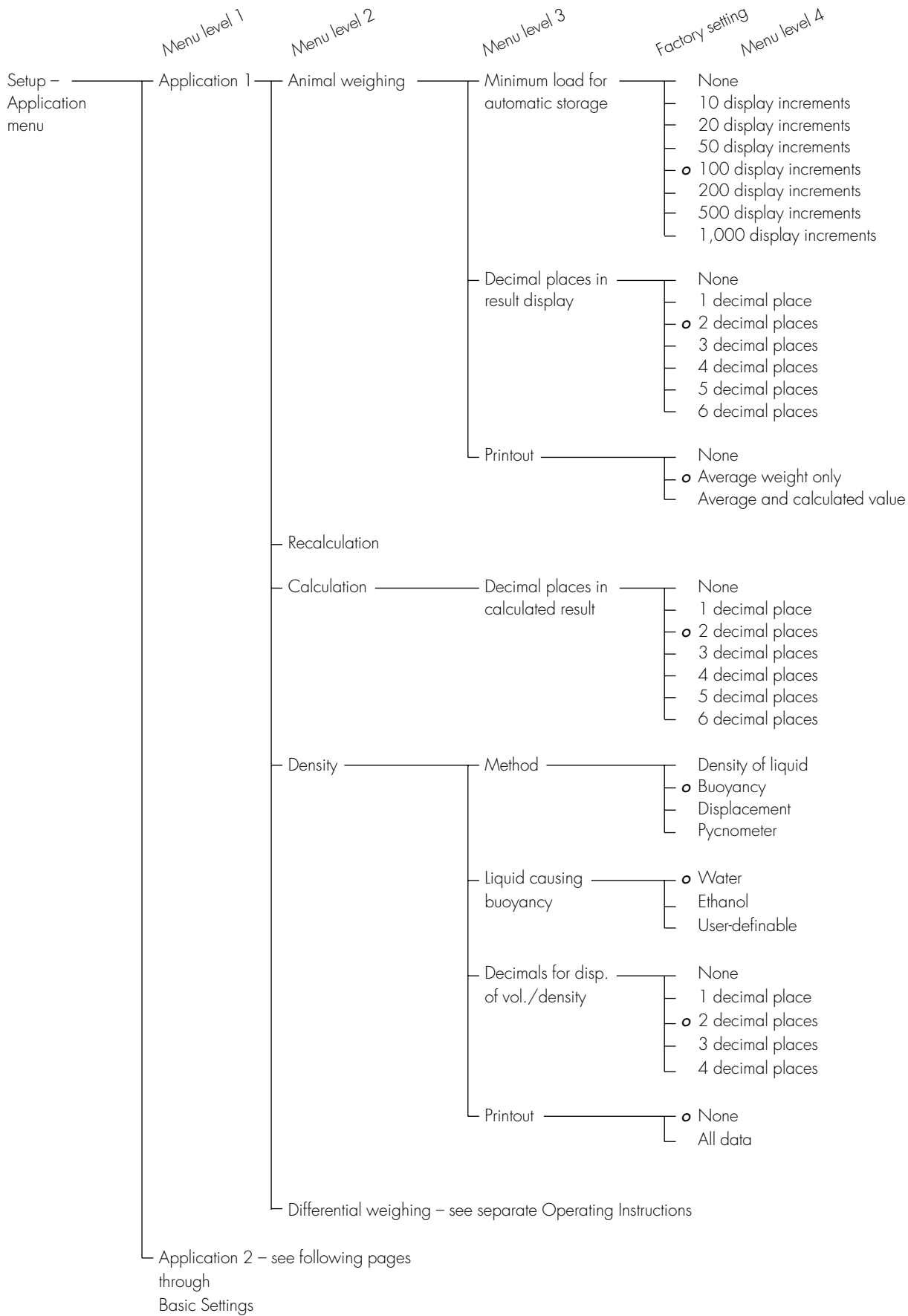

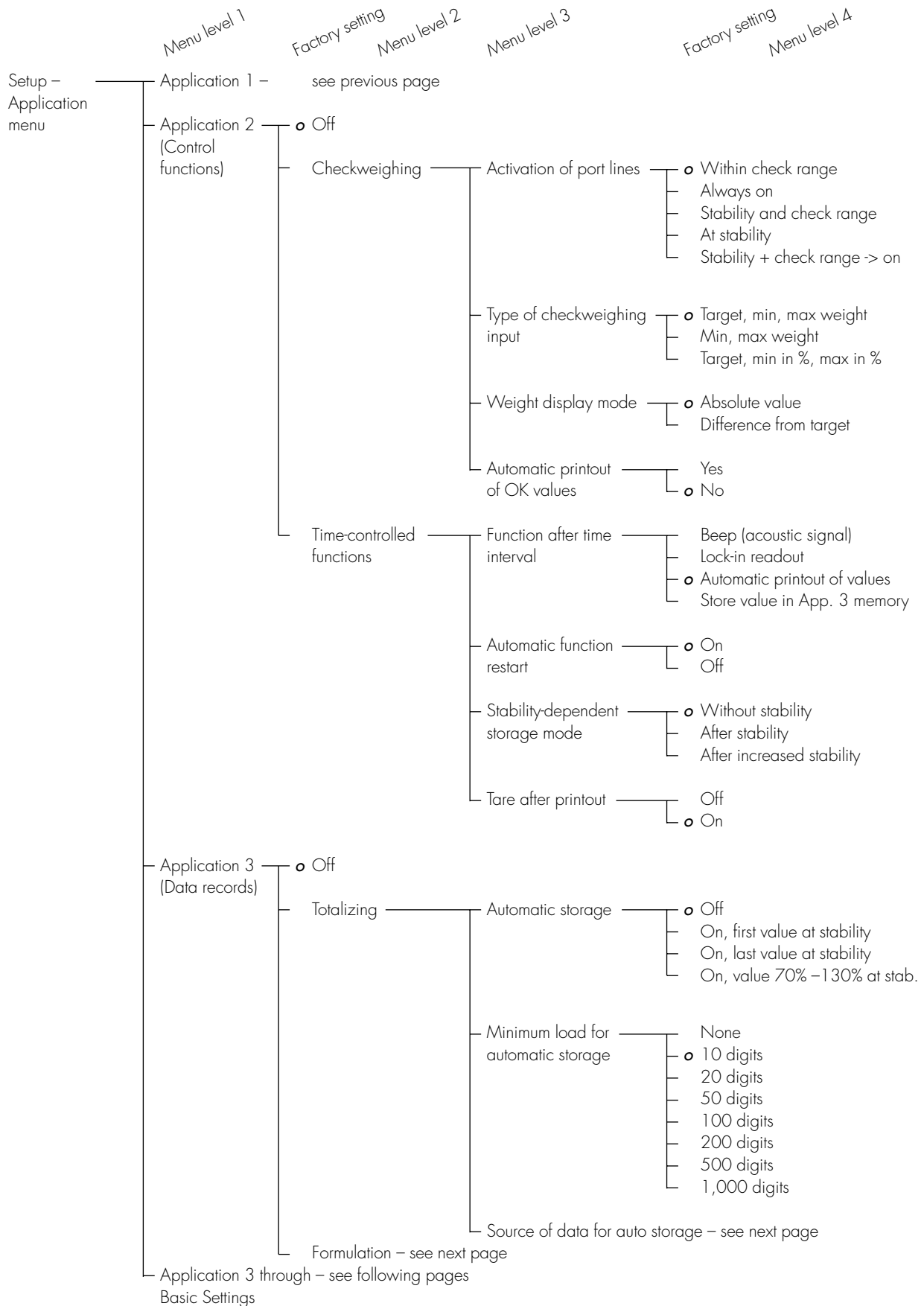

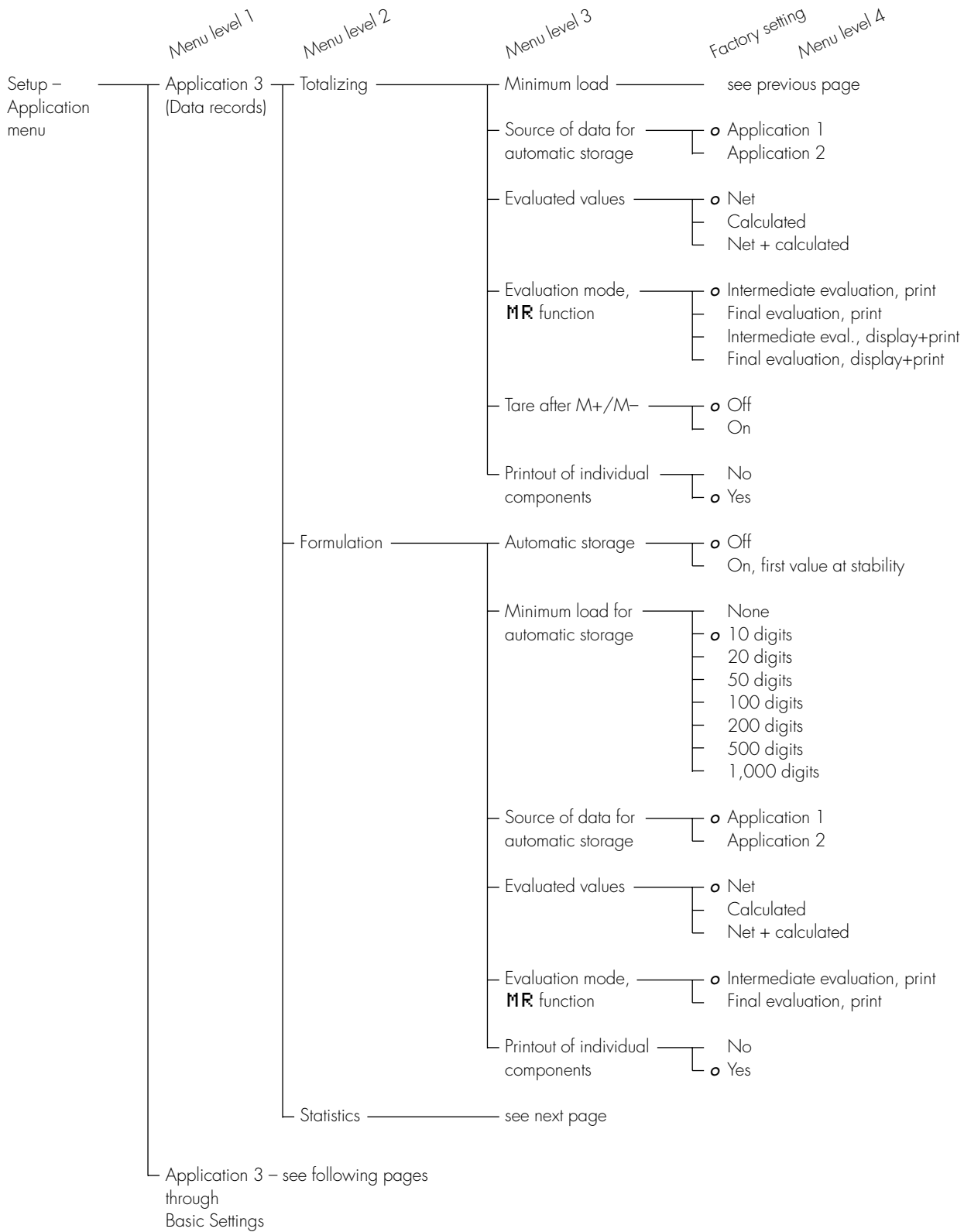

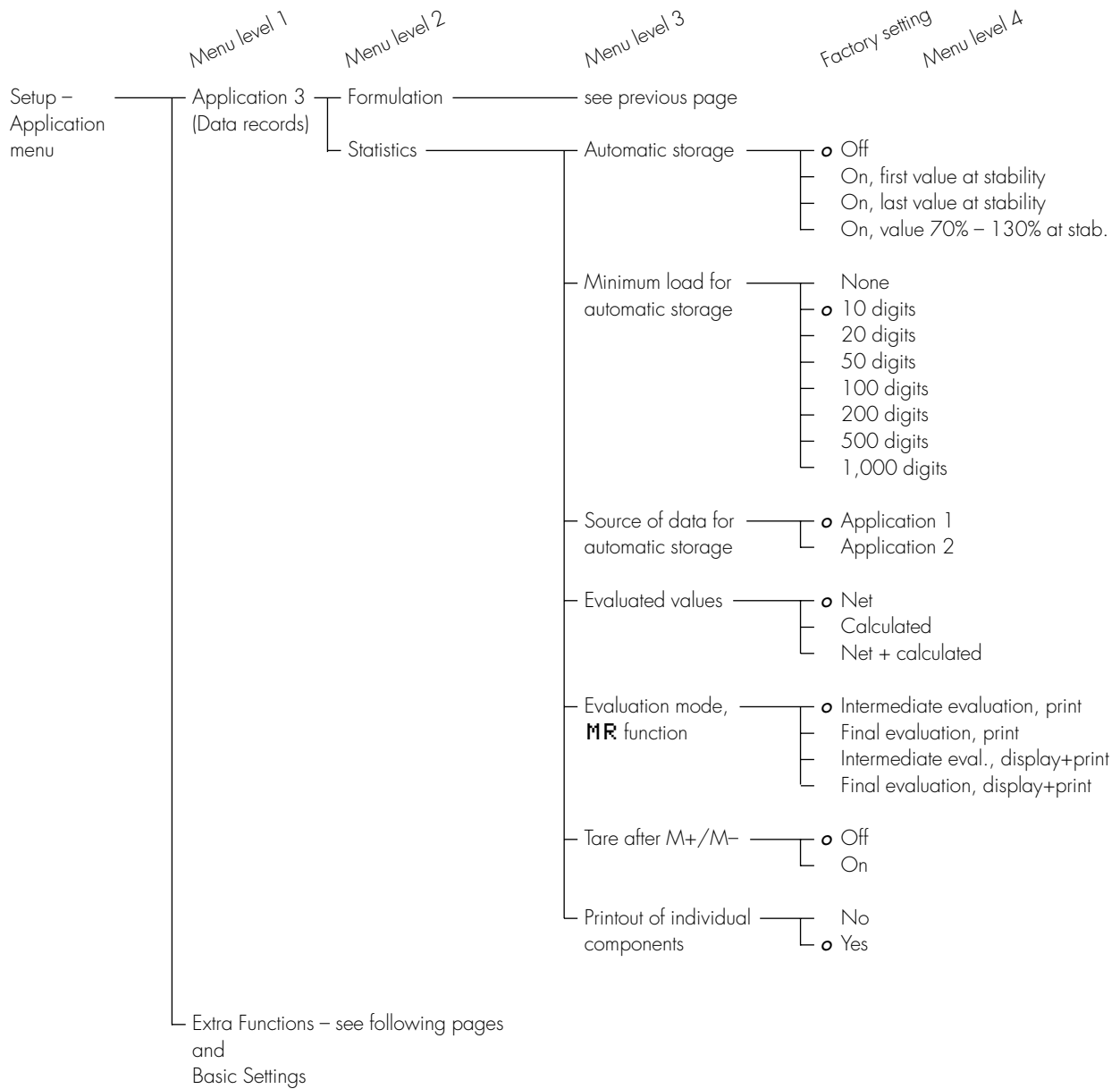

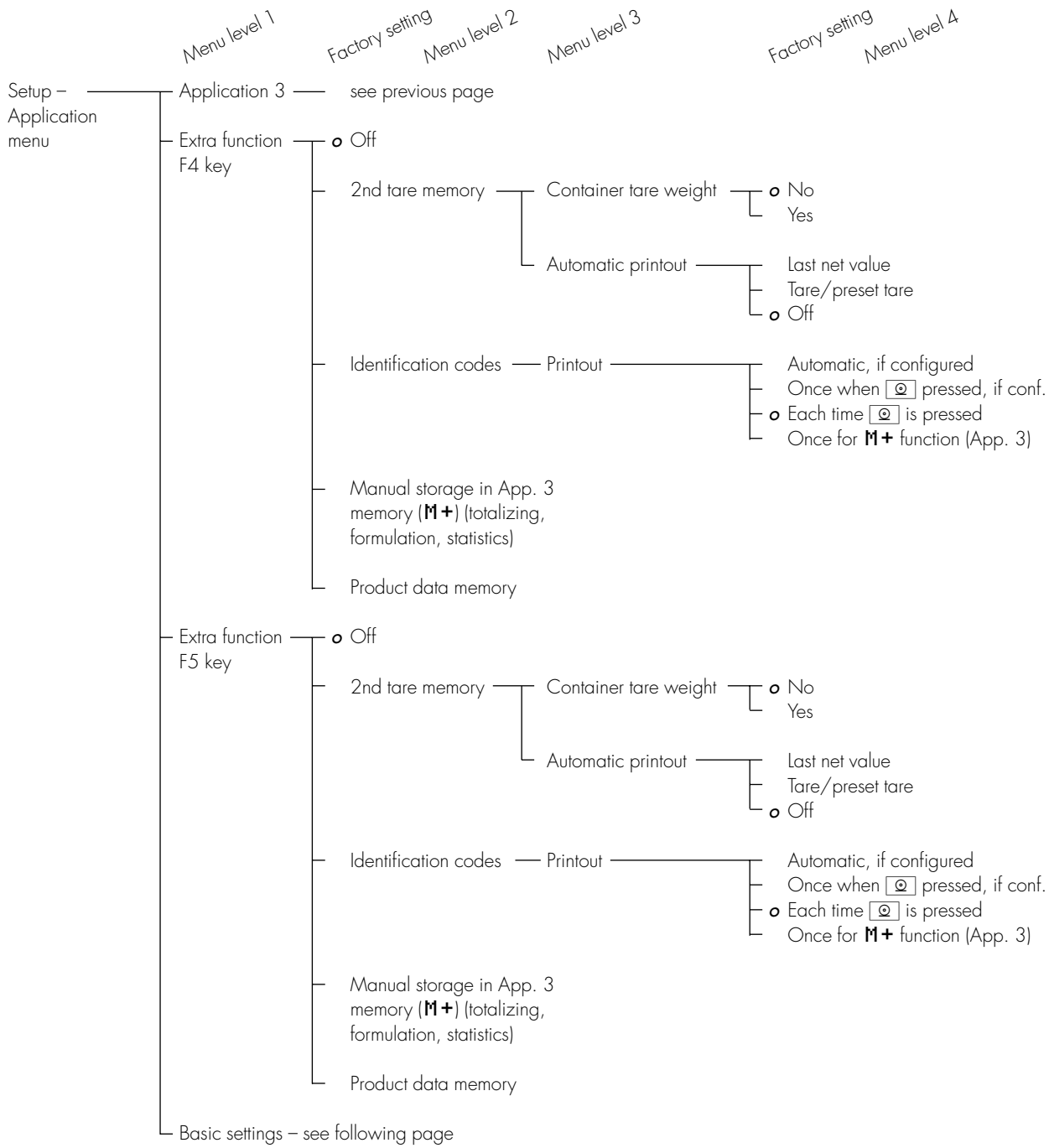

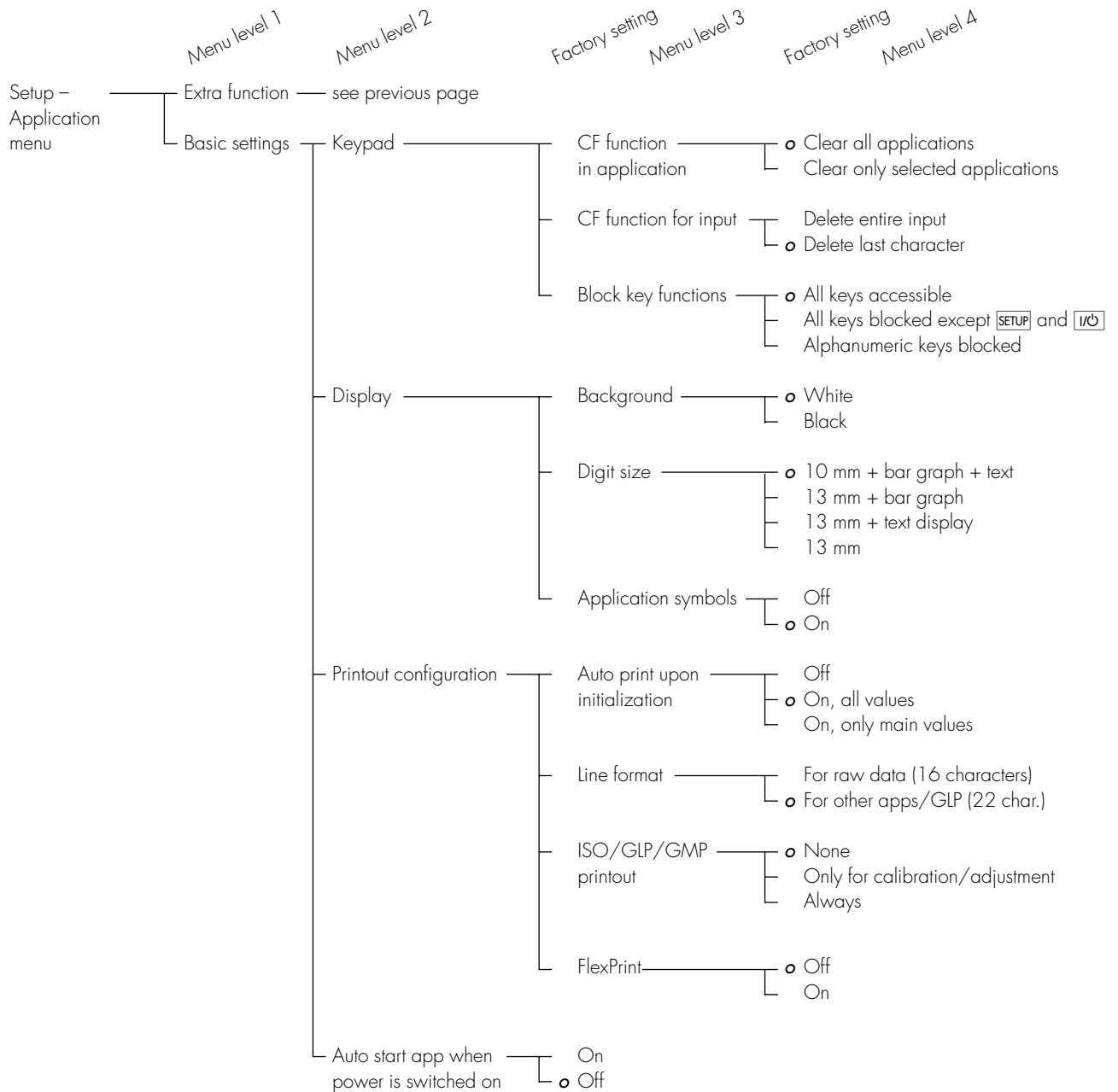

## Balance Operating Menu (Menu)

### Purpose

To configure the balance, i.e., adapt the balance to individual requirements by selecting from a list of parameter options in a menu. You can block access to this menu by assigning a password.

### Features

The parameters are grouped together as follows (menu level 1):

- 1 Balance functions
- 5 Interface
- 6 Print in weighing mode
- 8 Extra functions
- 9 Reset menu

### Factory Settings

The factory-set configurations are marked with an "o" in the list starting on page 30.

### Preparation

- Select the Setup program:  
Press **SETUP**
- > **SETUP SELECTION** is displayed
- Select the balance menu:  
Press the **Menu** soft key  
If a password has been assigned:  
> The password prompt is displayed
- Enter the password
- Confirm the password entered:  
Press the **↓** soft key
- > The balance menu is displayed (1st menu level):



- Select the next group:  
Press the **↓** soft key (arrow down)
- To select the previous item in the group: press **↑** soft key (arrow up)
- To select one item lower in the group: Press the **→** soft key (arrow right)
- To return to the next level up: Press the **←** soft key (arrow left)
- Confirm the selected menu item:  
Press the **↓** soft key
- Toggle to the Setup:Application menu (see also page 17):  
Press the **App** soft key

### Additional Functions

- Save settings and exit the application menu:  
Press the **←←** soft key
- > Restart the application
- Print parameter settings:
  - When the 3rd menu level is displayed: Press **☉**
  - > Printout (Example)  
**6 1 Manual/auto pr**  
**2 Manual with s**
  - When the 3rd menu level is displayed: Press **☉**
  - > Printout (Example)  
**6 Print in weighing**  
-----  
**6 1 Manual/auto pr**  
**2 Manual with s**  
**6 2 Stop auto prin**  
**2 Not possible**  
**6 3 Time-dependent**  
**1 1 display upd**  
**6 4 Print on reque**  
**1 Off**
  - When the 1st menu level is displayed: Press **☉**
  - > All current parameters settings are printed

## Practical Example

Adapt the balance to ambient conditions of "extreme vibration."

Step	Key (or instruction)	Display/Output
1. Select Setup	<b>SETUP</b>	<pre> SETUP          SELECTION Confis =&gt; Printout configuration App    =&gt; Application menu Info   =&gt; Balance parameters Menu   =&gt; Balance menu Ineut  =&gt; User data &lt;&lt;    ConfisApp  Info  Menu  Ineut           </pre>
2. Select the balance menu	Press the <b>Menu</b> soft key	<pre> SETUP          MENU [  ] 1 Balance functions 5 Interface 6 Print in weishins mode 8 Extra functions 9 Reset menu &lt;&lt;     App                      v        &gt;           </pre>
3. Confirm selection of balance function menu	Press the <b>➤</b> soft key	<pre> MENU          BAL.FUNC. [ 1- ] 1 Adapt filter 2 Application filter 3 Stability range 5 Tarins 6 Auto zero &lt;&lt;     App        &lt;             v        &gt;           </pre>
4. Confirm selection of filter adaptation menu item	Press the <b>➤</b> soft key	<pre> BAL.FUNC.    ADAPT FILT. [ 1- 1- ] 1 Minimum vibration o 2 Normal vibration 3 Strongs vibration 4 Extreme vibration &lt;&lt;     App        &lt;      ^      v        ↓           </pre>
5. Menu level 3: Select the desired item	Press the <b>▼</b> soft key twice	<pre> BAL.FUNC.    ADAPT FILT. [ 1- 1- ] 1 Minimum vibration o 2 Normal vibration 3 Strongs vibration o 4 Extreme vibration &lt;&lt;     App        &lt;      ^             ↓           </pre>
6. Confirm selection	Press the <b>↓</b> soft key	<pre> BAL.FUNC.    ADAPT FILT. [ 1- 1- ] 1 Minimum vibration 2 Normal vibration 3 Strongs vibration o 4 Extreme vibration &lt;&lt;     App        &lt;      ^             ↓           </pre>
7. Set other menu codes, if desired	<b>▼ ^</b> soft keys	
8. Confirm setting and exit Setup	Press the <b>&lt;&lt;</b> soft key	

## Setup Parameters, "Balance Menu" (Overview)

- Factory setting
- ✓ User setting

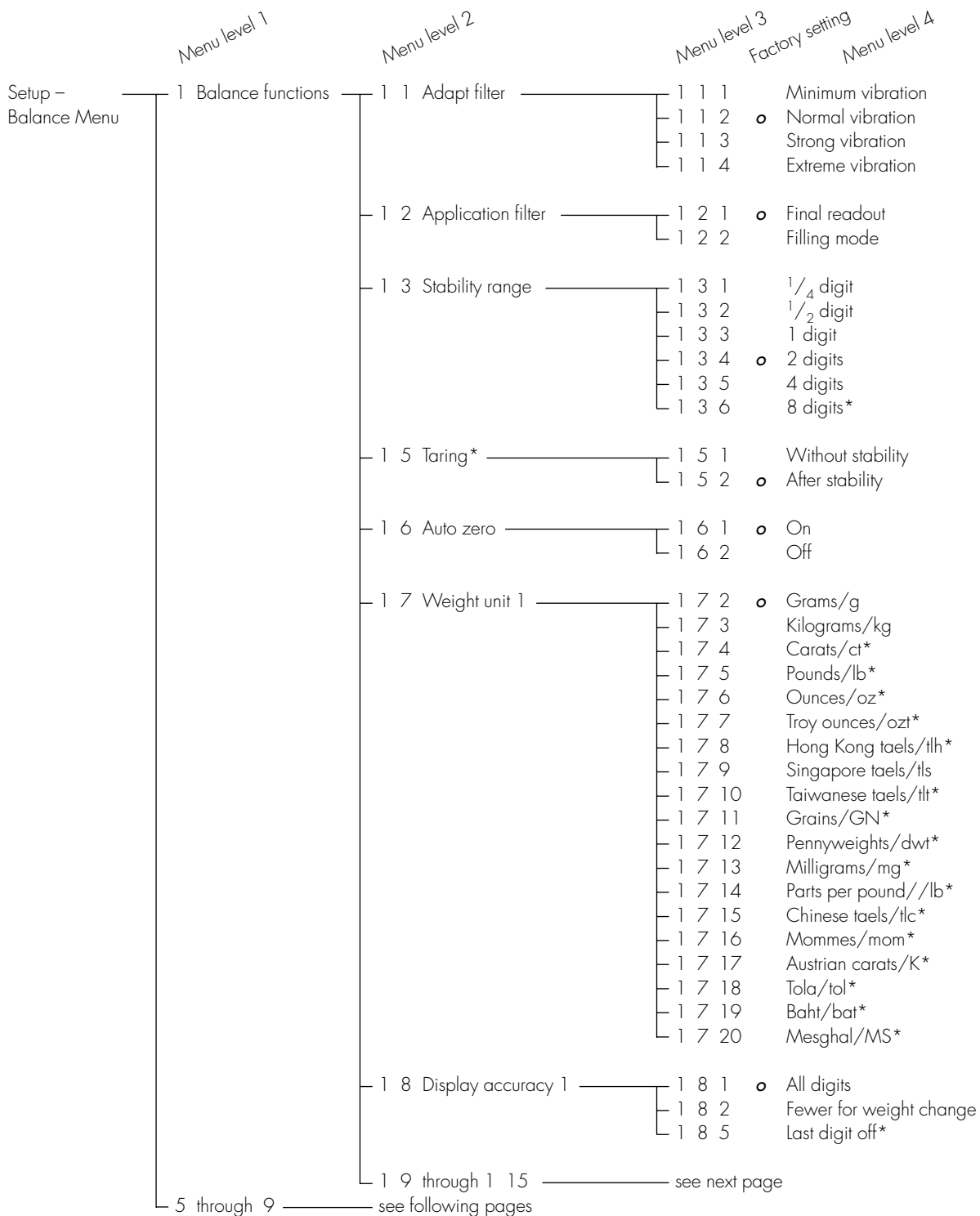

\* = not applicable to verified balances

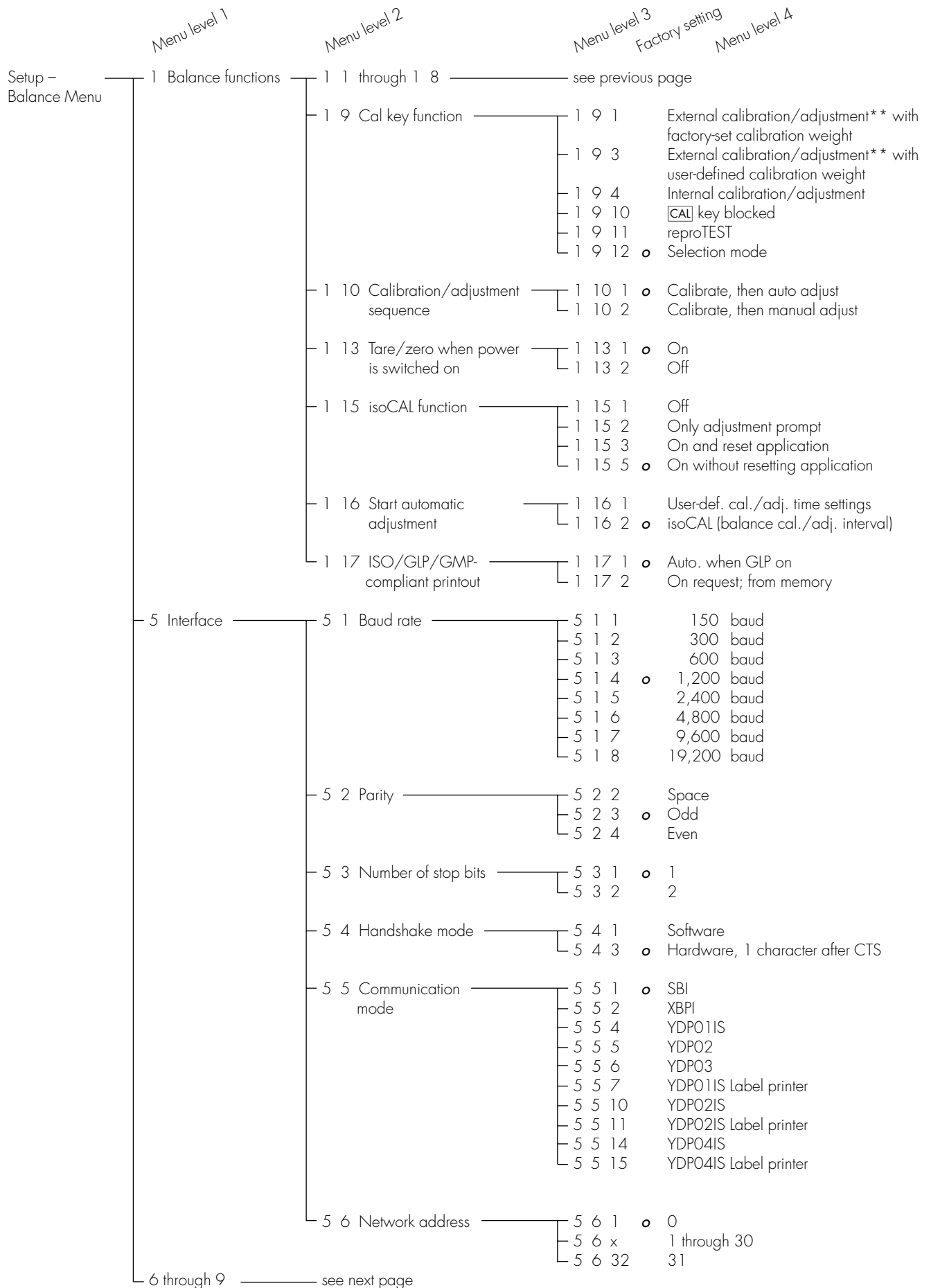

\* = not applicable to verified balances

\*\* = verified balances of accuracy class **II** cannot be adjusted, only calibrated

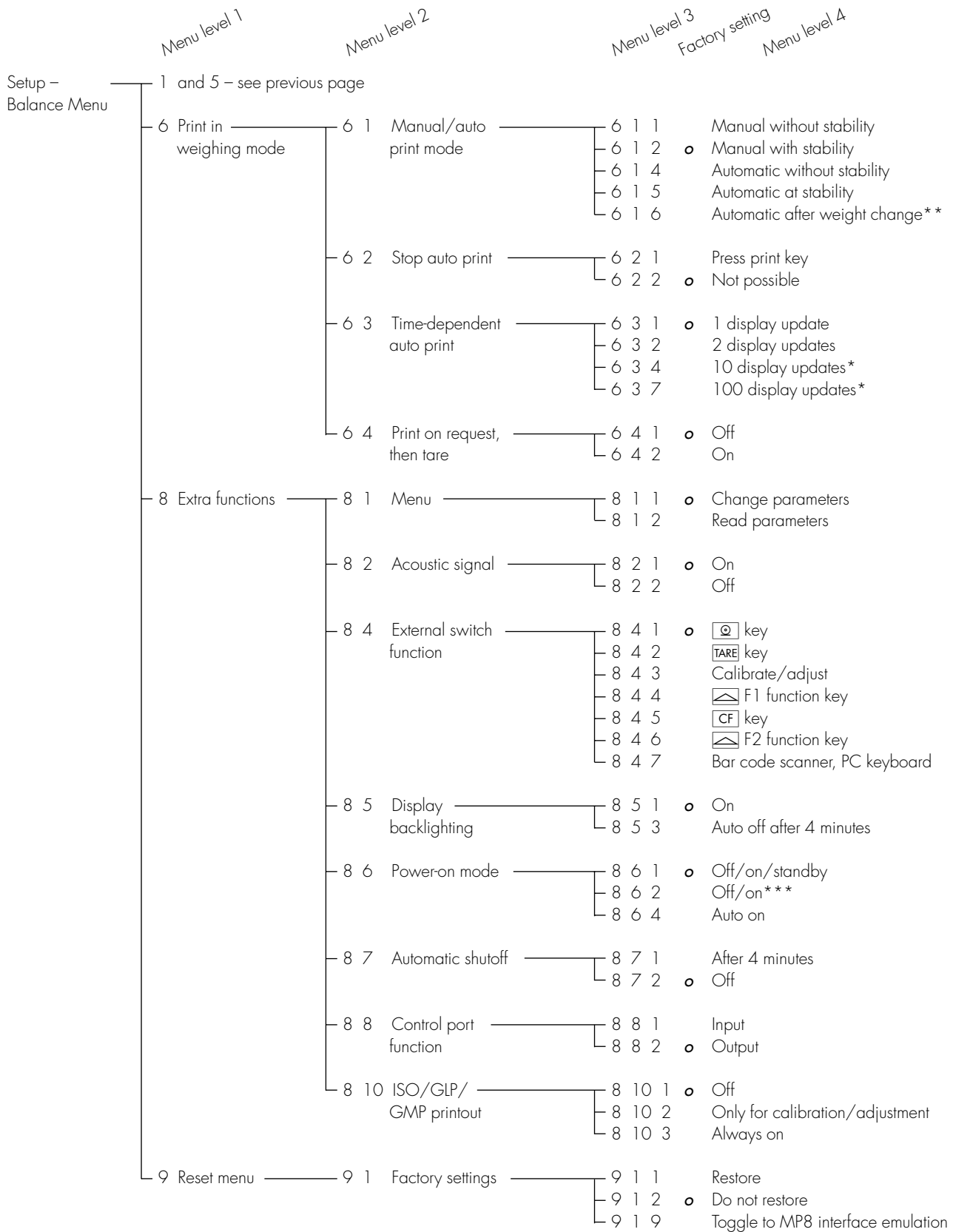

\* = not applicable to verified balances

\*\* = auto print when load change is >10 d; no printout until residual difference in load value is < 5 d

\*\*\* = not applicable to balances with a weighing capacity of ≥ 16 kg

## Configuring the Printout (Conf 3)

### Purpose

You can configure individual printout formats for each application. With the formulation, totalizing and statistics application, you can also define the values to be printed on the total printout when the **MR** key is pressed.

In the Setup menu you can configure individual, component or total data records that contain the items available for printouts in each application. Configure these records after you have configured the applications, because some entries in the data record are application-dependent.

### Features

- Maximum items in a data record: 60
- Individual, component and total records can be configured separately
- Output individual record:  
Press **Ⓞ**  
Automatic printout of application data:  
Results from animal weighing or density application (Setup: Application: Density: Printout: All data)  
OK values from checkweighing application, time-controlled printouts, 2nd tare memory data
- Output component printout:  
Totalizing, formulation or statistics by pressing **M+** or **M-** (Setup: Application 3: ..., Printout components: On)
- Output total record:  
For totalizing, formulation or statistics by pressing **MR**
- Data records are deleted after an application or an extra function is activated or ended in the application menu
- A new pick list is created based on the currently active application programs and extra functions
- Printout items can be deleted individually
- No printout is generated when the following settings are configured:  
Menu: Print in weighing mode: automatic  
(6 - 1 - 4, 6 - 1 - 5, 6 - 1 - 6)  
Application: printout configuration:  
Line format: For raw data  
(16 characters)
- Form feed:  
Select the "YDPO2IS-label" print mode (menu code 5 - 5 - 11) to configure automatic form feed to the beginning of the next label

### Additional Functions

- Save settings and exit printout configuration:  
Press the **◀◀** soft key
- > Start application
- Print parameter settings:
  - When the select bar is on **List** or **Select**:  
Press **Ⓞ**
  - > Printout (example)

```

-----
Date/time
S ID
Ref. weight
Piece count
Minimum
Nom.no.weighs
etc.
  
```

Data Items for the Printout:

Parameter	Display text	Indiv.	Comp.	Total
Blank line**	Blank line	x	x	x
Dotted line**	-----	x	x	x
Form feed*	Form feed	x	x	x
Date/time*	Date/time	x	x	x
Time with seconds*	Time	x	x	x
GLP/GMP-header*	GLP header	x	x	x
GLP/GMP-footer*	GLP footer	x	x	x
Sample ID*	S ID	x	x	x
ID 1*	ID1	x	x	x
ID 2*	ID2	x	x	x
ID 3*	ID3	x	x	x
ID 4*	ID4	x	x	x
Net weight*	Net	x		
Gross weight*	Gross	x	x	x
Tare weight*	Tare	x		
Preset tare/ Tare 1 weight*	Tare1 (T1/PT1)	x	x	x
<b>With the "Counting" application:</b>				
Reference quantity	Ref. quantity	x	x	x
Reference weight	Ref. weight	x	x	x
Piece count	Piece count	x		
<b>With the "Weighing In Percent" application:</b>				
Reference percentage	Ref. percent	x	x	x
Reference weight	Ref. weight	x	x	x
Percentage	Percent	x		
<b>With the "Animal Weighing" application:</b>				
Number of weighing operations	No. of weighs	x	x	x
Calculation factor	Factor	x	x	x
Average animal weight	Mean value	x		
Calculated average	Mean factor	x		
<b>With the "Calculation" application:</b>				
Equation	Equation	x	x	x
Calculated result	Calc. result	x		
<b>With the "Density" application:</b>				
Temperature	Temperature	x	x	x
Imm. liquid	Liquid	x	x	x
Weight in air	Wt. in air	x		
Weight in liquid	Wt. in liquid	x		
Weight of sample and liquid	Total wt.	x		
Calculated density	Calc. density	x		
Calculated volume	Calc. volume	x		
Buoyancy correction	Buoyancy corr.	x		
Air buoyancy correction	Air buoy. corr.	x		
Expansion coefficient	Exp. coeff.	x		
Volume of the plummet	Plummet vol.	x		

Parameter	Display text	Indiv.	Comp.	Total
<b>With the "Checkweighing" application:</b>				
Target value	Target	x	x	x
Minimum value	Minimum	x	x	x
Maximum	Maximum	x	x	x
<b>With the "Time-Controlled Functions" application:</b>				
Time/interval	Time interval	x		
<b>With the "Totalizing/Statistics" application:</b>				
No. of weights	No. of wts.		x	x
Weight of trans.	Trans.wt.		x	
Average weight	Average wt.			x
Standard deviation – weight	Std.dev.wt.			x
Variation coefficient – weight	Var.coeff.wt.			x
Weight total	Wt. total			x
Minimum weight	Min. wt.			x
Maximum weight	Max. wt.			x
Difference weight	Diff. wt.			x
No. of calc. values	No. of calc.val.		x	x
Calc. value – transactions	Calc.val.trans.		x	
Mean calc. value	Mean calc.val			x
Standard deviation – calculated values	Std.dev.calc.			x
Variation coefficient – calc. values	Var.coeff.calc.			x
Total – calc. values	Total calc.			x
Minimum – calc. values	Min. calc.			x
Maximum – calc. values	Max. calc.			x
Difference – calc. values	Diff. calc.			x
Target no. of weighing operations	Nom.no.wghs		x	x
<b>With the "Formulation" application:</b>				
Number of components	Number		x	x
Net components	Net component		x	
Components – calculated	Net transact.		x	
Total net components	Net/comp.calc.			x
Total calc. components	Tot.comp.calc.			x
Preset tare/ Tare 2 weight	Tare2	x	x	x
Target no. of weighing operations	Nom.no.wghs		x	x

\*= Items are available independent of the applications selected

\*\*= Items are available independent of the applications selected and can be selected more than once (60 items per data record max.)

## Example:

Configure an Individual Printout for the Counting Application to include Dotted Line, Date/Time, Piece Count and Net Weight

Step	Key (or instruction)	Display/Output
1. Access the Setup menu and select "Configuration"	<b>SETUP</b> , then the <b>Config</b> soft key	<pre> SETUP          CONFIG Total =&gt; Printout after pressing MR Comp. =&gt; Printout after M+/M- Indiv. =&gt; Printout f. app./weighing           </pre>
2. Select "Individual printout"	<b>Indiv.</b> soft key	<pre> LIST          INDIV.PRT  SELECTION ----- Blank line Form feed Date/time Time           </pre>
3. Select "Blank line"	<b>&gt;</b> , <b>v</b> , <b>↓</b> soft key	<pre> LIST          INDIV.PRT  SELECTION ----- Blank line Form feed Date/time Time           </pre>
4. Select "Date/time"	<b>v</b> soft key twice, then <b>↓</b> soft key	<pre> LIST          INDIV.PRT  SELECTION ----- Date/time Form feed Time GLP header           </pre>
5. Select "Piece count"	<b>v</b> soft key repeatedly, then <b>↓</b> soft key	<pre> LIST          INDIV.PRT  SELECTION ----- Date/time Piece count Net (N) Gross (G#) Ref. quantity Ref. weight Tare set           </pre>
6. Select "Net weight"	<b>^</b> soft key repeatedly, then <b>↓</b> soft key	<pre> LIST          INDIV.PRT  SELECTION ----- Date/time Piece count Net (N) Gross (G#)           </pre>
7. Exit Setup "Configuration"	Press the <b>&lt;&lt;</b> soft key	
8. Perform weighing operations, then press	<b>⊙</b>	<pre> ----- 14.05.1997      09:19 Qnt   +      598 pcs N     +    2003.13 g           </pre>

## "Info" Display (Info)

### Purpose

To have information about the specific balance ("device") and "FlexPrint" displayed

### Display specific information about the balance

- Select the Setup program:

Press **SETUP**

> "SETUP SELECTION" is displayed.

SETUP	SELECTION
Config =>	Printout configuration
App =>	Application menu
Info =>	Balance parameters
Menu =>	Balance menu
Input =>	User data
<<	ConfigApp Info Menu Input

- Select information:

Press the **Info** soft key

- Press **➤** soft key to confirm "Device information"

> Specific information about the balance is displayed (see also the "Data Output Functions" section in the chapter entitled "Operating the Balance"):

SETUP	INFO
Version no.:	01-35-16
Bal. ver. no.:	00-20-13
Model:	LA5200P
Serial no.:	70906913
<<	

- Print information:

Press **Ⓞ**

> Example of a printout

**Mod.** LA5200P  
**Ser. no.** 70906913  
**Ver. no.** 01-35-16

(Software version, display and control unit)

**Ver. no.** 00-20-13

(Software version, weighing platform)

- Return to

**SETUP SELECTION:**

Press the **◀◀** soft key

### Exiting the Setup menu

If you use the **◀◀** soft key:

- The software will be restarted if you have changed a setting.
- The software will not be restarted if you have kept the same settings. In this case, the program will return to its initial state before you press the **SETUP** key.

If you press the **SETUP** key:

- When you exit the Setup menu, the software is generally restarted.

> Balance returns to previous status

### Displaying "FlexPrint" Information

- Select the Setup menu:

press the **SETUP** key

> "SETUP" is displayed:

SETUP	SELECTION
Config =>	Printout configuration
App =>	Application menu
Info =>	Balance parameters
Menu =>	Balance menu
Input =>	User data
<<	ConfigApp Info Menu Input

- To select information:

press "**Info**" soft key

SETUP	INFO
Device Information	
FlexInfo	
<<	

- Select "FlexInfo":

press **⏴** soft key and **➤** soft key

> FlexPrint information is displayed:

with print instruction file name, software ID and version number:

SETUP	INFO	FLEXINFO
PDIRECT	ID---	U.---
PGMFOOT	ID403	U.000001
PGMHEAD	ID403	U.000001
<<		

- To select and view a particular print file name with software ID (for example, ID403), if desired: press key **⏴** or **⏵** as required

> If the display shows **ID---**:  
 The weight block for legal metrology is not printed by this print file.

> Display of version number:

**U. xx. xx. xx**

created by Sartorius:

**U.S. xx. xx. xx**

- Return to SETUP overview:

press the **◀** soft key

- Exit Setup menu:

press the **◀◀** soft key

> The device returns to the previous mode.

## Operating the Balance

### Basic Weighing Function

#### Purpose

The basic weighing function is always accessible and can be used alone or in combination with an application program (Toggle between Weight Units, Counting, Weighing in Percent, etc.).

#### Features

- Taring the balance
- Assigning IDs to weights
- Printing weights
- Printing ID codes for weights

#### Factory Settings

Tare: **After stability**

Manual/auto print mode:  
**Manual with stability**

Line format:  
**For other apps/GLP  
(22 characters)**

#### Soft Key Functions

**Cal** Initiate calibration/adjustment routine

**isoCAL** Press to start isoCAL routine

**S ID** Store ID entered

#### Below-Balance Weighing

A port for a below-balance weighing hanger is located on the bottom of the balance.

Balances with a capacity  $\leq 12$  kg:

- Open cover plate (1) on the bottom of the balance

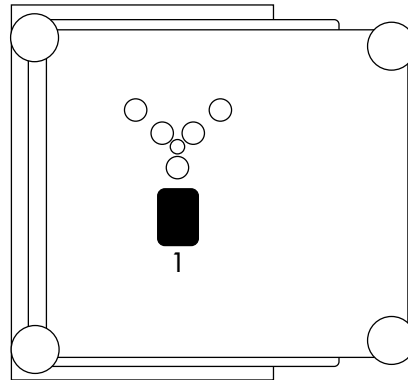

- Attach the sample (e.g., using a suspension wire) to the hook (2).

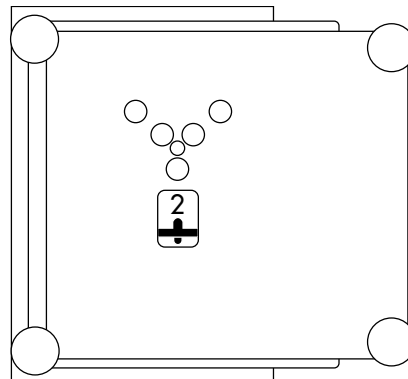

Balances with a weighing capacity  $\geq 16$  kg:

- Use a screwdriver to open the cover plate on the bottom of the balance

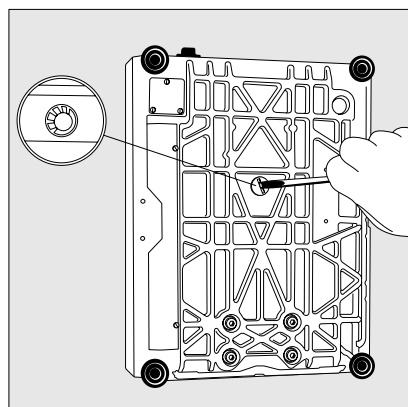

- Attach the hook ordered directly from Sartorius
- If necessary, install a shield for protection against drafts

Important Note Concerning Verified Balances Approved for Use as Legal Measuring Instruments in the EU\*:

The below-balance weighing port may not be opened or used when an approved balance is being operated as a legal measuring instrument.

#### Preparation

- Turn on the balance:  
Press **II/O**
- > The Sartorius logo is displayed
- To tare the balance, if desired:  
Press **TARE**
- > The **o** symbol is displayed when a verified balance is tared or zeroed ( $\pm 0.25$  digits).

Important Note Concerning Verified Balances Approved for Use as Legal Measuring Instruments in the EU\*:

The type-approval certificate for verification applies only to non-automatic weighing instruments; for automatic operation with or without auxiliary measuring devices, you must comply with the regulations of your country applicable to the place of installation of your balance.

- The temperature range indicated on the verification ID label must not be exceeded during operation

Example:  
MD BF 100  
**o** 0...+40 °C

\* including the Signatories of the Agreement on the European Economic Area

ID for weight value (if desired):

- Select the parameters "Line format" and "For other app./GLP" from the Setup menu: Press **SETUP**
- Select mode:  
Press the **APP** softkey
- Select Basic settings: Printout configuration: Line format  
See the chapter entitled "Configuring the Balance"
- Exit the Setup program:  
Press **<<** soft key

### Additional Functions

In addition to the functions:

- alphanumeric input
- taring (not during alphanumeric input)
- printing

you can also access the following functions from the weighing application:

- calibration (not during alphanumeric input)
- setup
- turning off the balance

#### Calibration

- Press **Cal**
- > See the section on "Calibration/Adjustment" for further instructions.

#### Setup

- Press **SETUP**
- > See the chapter entitled "Configuring the Balance" for further instructions.

#### Turning Off the Balance

- Press **OFF**
- > The balance shuts off
- > The display goes blank

#### Important Note Concerning Verified Balances of Accuracy Class $\text{I}$ :



To avoid measuring errors, the respective air density must be allowed for. The following formula is used to calculate the mass of the sample:

$$m = n_w \frac{1 - \rho_l / 8000 \text{ kg m}^{-3}}{1 - \rho_l / \rho}$$

$m$  = mass of the sample  
 $n_w$  = weight readout  
 $\rho_l$  = air density during weighing  
 $\rho$  = density of the sample

### Practical Examples

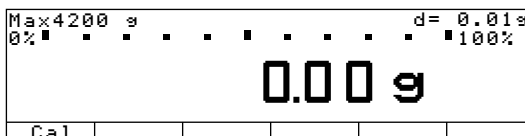
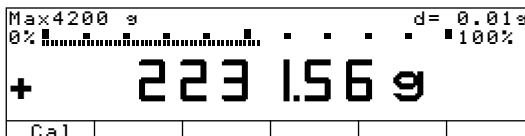
Example W1: Simple weighing

Step	Key (or instruction)	Display/Output
1. If necessary, tare the balance ( $\odot$ symbol: balance is tared, - verified balances only)	<b>TARE</b>	
2. Enter sample ID	see Example W2	
3. Determine sample weight (Example)	Place load on balance	
4. Print weight value	<b>PRINT</b>	

## Example W2

Enter "ABC123" as sample ID

Note:

- The sample ID generally applies to one weighing operation only
- The ID is deleted after data output

Step	Key (or instruction)	Display/Output
Initial status (balance unloaded) (ID can also be entered while balance is loaded)		
1. Select alphabetic input	<b>ABC</b>	
2. Select the required letter group	<b>ABCDEF</b> soft key	
3. Enter the letter "A" (To delete a letter:	<b>A</b> soft key <b>CF</b> )	
4. Select the letter group and enter "B"	<b>ABCDEF</b> soft key <b>B</b> soft key	
5. Select the letter group and enter "C"  (If only letters are entered, conclude input:	<b>ABCDEF</b> soft key <b>C</b> soft key  <b>ABC</b> )	
6. Enter the numbers 1, 2 and 3	<b>1</b> <b>2</b> <b>3</b>	
7. Store the ID (max. 20 characters)  - The next printout will include the sample ID	<b>S ID</b> soft key	

## Calibration, Adjustment, Linearization

### Purpose

Calibration is the determination of the difference between the weight readout and the true weight (mass) of a sample. Calibration does not entail making any changes within the balance.

Adjustment is the correction of this difference between the measured value displayed and the true weight (mass) of the sample, or the reduction of the difference to an allowable level within maximum permissible error limits.

Linearization is the procedure used to eliminate the deviation from weight readout plotted on the balance's ideal characteristic calibration curve and the actual weight readout. In other words, linearization reduces the amount of error of a weight displayed to its maximum permissible error limits. The ideal characteristic curve is a straight line plotted between zero load and maximum load.

### Available Features

Your balance can be calibrated externally (Balance menu: CAL key function; menu item **Ext. cal./adj.:** **factory-def. wt.** or **Ext. cal./adj.:** **user-defined wt.**) or internally (**Internal cal./adjustment**).

External calibration can be performed

- using a preset weight value **Ext. cal./adj.:** **factory-def. wt.**, or
- with a user-defined weight **Ext. cal./adj.:** **user-defined wt.**

The adjustment can be performed

- automatically following calibration: **Cal., then auto adjust.** or
- if desired, the adjustment operation can be started manually after calibration: **Cal., then manual adjust**

You can also configure whether the calibration mode

- will be activated according to the specific setting (external/internal) or
- can be selected by the user after pressing the **Cal** soft key: **Selection mode.**

You can have the balance automatically display an adjustment prompt after a certain time interval has elapsed since the last calibration/adjustment or when the ambient temperature changes by a defined amount.

You can also configure the balance to perform calibration and adjustment automatically (isoCAL) when the pre-set time and/or temperature limit is reached **On and reset application** and **On without resetting app.**

You can have the calibration/adjustment results documented in a ISO/GLP/GMP-compliant printout; see page 126.

### Factory Settings

Calibration/adjustment mode:  
**Selection mode**

Calibration/adjustment sequence:  
**Calibrate, then auto adjust**

isoCAL function (automatic initiation of cal./adj. sequence):  
**On without resetting app.**

### Releasing Access to External Calibration in Verified Balances of Accuracy Class (I)

- Remove the covering plate from the back of the balance housing
- Move switch 1 in the direction of the arrow

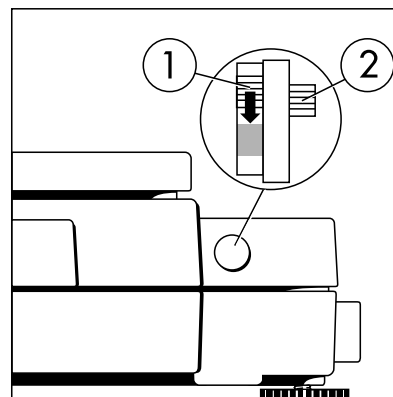

- > Switch down:  
external calibration accessible
- Switch up:  
external calibration blocked
- > Note:  
Do not move Switch 2

### For service technicians only:

#### External Calibration in Verified Balances of Accuracy Class (II)

- External calibration is blocked when the balance is used in legal metrology
- > External calibration can only be released after removing the verification control seal, in which case the validity of the verification becomes void and the balance must be re-verified
- External calibration can now be performed

## Preparation

Set the parameters for calibration and adjustment; e.g., with manual calibration/adjustment, isoCAL off

Step	Key (or instruction)	Display/Output
1. Switch on the balance		Sartorius logo Self test  
2. Select the Setup menu		
3. Select the Balance menu	<b>Menu</b> soft key	
4. Confirm selection of Balance functions	<b>&gt;</b> soft key	
5. Select CAL key function	<b>v</b> soft key repeatedly	
and confirm	<b>&gt;</b> soft key	 ○ = last setting selected
6. Select desired function and confirm (e.g., item 4)	<b>^</b> soft key, repeatedly, if necessary <b>↓</b> soft key	
7. Exit CAL key function	<b>&lt;</b> soft key	



## Selecting the Calibration/Adjustment Parameter

The setting **Selection mode** must be selected in the Setup menu (factory setting).

After pressing the **Cal** soft key, you can choose from among the following settings by pressing the **Select** soft key:

- External calibration/adjustment with the preset calibration weight:  
**Ext. cal./adj.:  
factory-def. wt.**
- External calibration/adjustment with a calibration weight determined by the user:  
**Ext. cal./adj.:  
userdefined wt.**
- Internal calibration/adjustment  
**Internal cal./  
adjustment**
- Reproducibility test  
**reproTEST**
- Start the desired routine:  
Press the **Cal** soft key again

In the selection mode: Perform external calibration followed by automatic adjustment with the factory-set weight

Configuration:  
factory settings

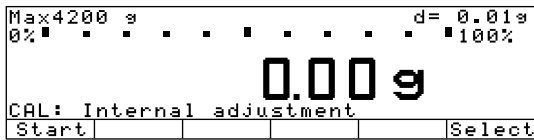
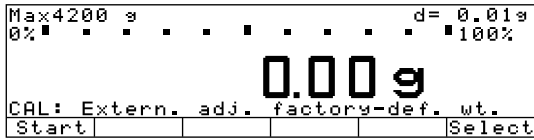
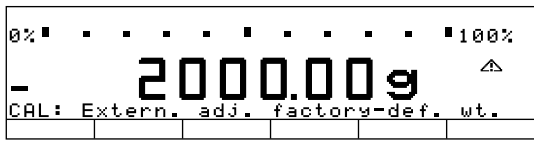
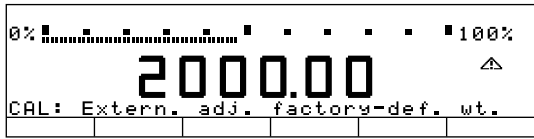
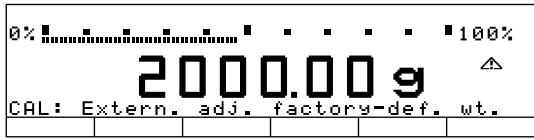
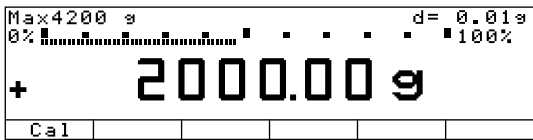
Step	Key(s) (or instruction)	Display/Output
1. Select Calibration	<b>Cal</b> soft key	
2. Select external calibration/adjustment with factory-defined weight  (for balances of accuracy class <b>II</b> , only "external adjustment" is possible)	2 x <b>Select</b> soft key	
3. Start external calibration/adjustment	<b>Start</b> soft key	
4. Place the weight on the balance (e.g., 2,000.00 g) Minus sign -: Weight too low Plus sign + Weight too high no plus/minus sign: Weight o.k.  This is displayed after calibration, for approx. 10 seconds:  (on verified balances, the difference between the displayed weight and the true weight (mass) is displayed)	Place weight on balance	 
5. Unload the balance (ISO/GLP/GMP printout: see page 126)		

## Internal Calibration/Adjustment

First set either **Internal cal. adjustment** or **Selection mode** (factory setting) in the Setup menu (Balance menu: Balance functions).

Inside the balance housing is a built-in motorized calibration weight.

The internal calibration/adjustment sequence is as follows:

- Select the calibration function:  
Press the **Cal** soft key and then the **Start** soft key
- > The internal calibration weight is applied automatically
- > The balance is calibrated
- > If the setting **Calibrate, then auto adjust** is selected in the Balance menu, the balance is now automatically adjusted
- > If the setting **Calibrate, then manual adjust** is selected in the Balance menu, you can end "Internal cal/adjustment" now; to start it, press the **Start** soft key without adjusting the balance (see "Calibration and Adjustment Sequence", next column)
- > The internal calibration weight is removed
- > (ISO/GLP/GMP printout: see page 126)

## Calibration and Adjustment Sequence

In the Setup menu, you can configure the balance so that:

- calibration is always followed automatically by adjustment  
**Calibrate, then auto adjust** (factory setting) or
- you have the choice of ending the sequence or starting adjustment after calibration  
**Calibrate, then manual adjust**

If no deviation is determined in calibration, or the deviation is within the tolerance limits dictated by the degree of accuracy you require, it is not necessary to adjust the balance. In this case, you can end the calibration/adjustment sequence after calibration. There are 2 softkeys active at this point:

- **Start** to start adjustment
- **End** to end the sequence



## isoCAL: Automatic Calibration and Adjustment

First set either **On and reset the application** or **On without resetting the app.** (factory setting) in the Setup: Balance menu. The "isoCAL" display automatically begins flashing if the ambient temperature changes in relation to the temperature at the time of the last calibration/adjustment, or after a defined time interval has elapsed. The balance is telling you that it wants to adjust itself.

This automatic calibration prompt is triggered when:

- The change in temperature or the elapsed time interval is greater than that shown in the table at the right
- The balance status does not correspond to Setup configurations
- No number or letter input is active
- The load has not been changed within the last 2 minutes
- The balance has not been operated within the last 2 minutes
- The load on the balance does not exceed 2% of the maximum capacity

- When you turn on the balance after it had been disconnected from power (only on verified balances with a readability of  $\leq 0.1$  mg)

When these requirements are met, **C** is displayed in the measured value line. If the balance is not operated and the load is not changed, internal calibration and adjustment starts after 15 seconds have elapsed.

### Automatic Calibration and Adjustment at Set Times\*

Select either **On and reset application** or **On without resetting app.** (factory setting) in the Setup menu.

In the Setup: Input menu, you can now enter up to three different times of day for automatic calibration/adjustment. When one of these times is reached, the balance will display the flashing calibration prompt ("isoCAL"). Calibration/adjustment is not performed if the balance is

\* not applicable to verified balances

off or in the Setup mode at the time set for calibration.

If the balance is being operated at the time set for automatic calibration/adjustment, the calibration/adjustment sequence is prompted afterward.

Automatic calibration/adjustment is prompted at set times when:

- The set time is reached
- The balance status does not correspond to Setup configurations
- No alphanumeric input is active (e.g., equation for calculation)
- The load has not been changed within the last 2 minutes
- The balance has not been operated within the last 2 minutes
- The load on the balance does not exceed 2% of the maximum capacity

When these requirements are met, **C** is displayed in the measured value line.

If the balance is not operated and the load is not changed, internal calibration and adjustment starts after 15 seconds have elapsed.

In the Setup menu, you can configure the balance so that after calibration and adjustment

- the application program is restarted **On and reset the application**
- the application program remains at its previous status **On without resetting the app.**

Also in Setup, you can configure the balance so that it displays a calibration prompt, but does not perform the calibration/adjustment functions automatically **Only adjustment prompt**

### Switching Off the isoCAL Function

in Precision Balances with a Readability  $\geq 1$  mg Used as Legal Measuring Instruments in the EU\*:

Automatic calibration and adjustment is also performed even when **Off** or **Only adjustment prompt** is set in the Setup menu.

Limited temperature range:

- Balances of accuracy class **(I)**:  $+15^{\circ}\text{C}$  to  $+25^{\circ}\text{C}$  ( $59^{\circ}\text{F}$  to  $77^{\circ}\text{F}$ )
- Balances of accuracy class **(II)**:  $+10^{\circ}\text{C}$  to  $+30^{\circ}\text{C}$  ( $50^{\circ}\text{C}$  to  $86^{\circ}\text{C}$ )

Extended temperature range:

- $0^{\circ}\text{C}$  to  $+40^{\circ}\text{C}$  ( $32^{\circ}\text{F}$  to  $104^{\circ}\text{F}$ )

You can switch off the automatic adjustment function on verified balances with a readability  $\geq 1$  mg:

- after modification by the Sartorius Customer Service
- > Subsequently the balance can only be used when the ambient temperature range is within legally defined limits.
- The isoCAL function cannot be switched off on balances with a readability  $\leq 0.1$  mg

\* including the Signatories of the Agreement on the European Economic Area

Fully automatic adjustment is initiated under the following conditions:

Model	when the temperature changes by	after a time interval of
LA310S, LA230S, LA230P, LA120S, LA3200D, LA1200S, LA2000P	1.5°C	4 h
LA620S, LA620P, LA6200S, LA4200S, LA5200P, LA8200S, LA8200P	2°C	6 h
LA220S, LA2200S, LA2200P, LA34001P, LA34001S, LA64001S	4°C	12 h
LA820, LA420, LA16001S, LA12000S, LA12000P, LA6200, LA4200, LA2200, LA34000	4°C	24 h

These values are also factory set in the verified or verifiable models (with the model number suffix -OCE).

## Determination of the Repeatability (reproTEST)

### Definition

Repeatability is the ability of the balance to display identical readouts when it is loaded several times with the same weight under constant ambient conditions.

The standard deviation for a given number of measurements is used to quantify the repeatability.

### Purpose

The "reproTEST" function automatically determines the reproducibility of results (based on 6 individual measurements). In this way, the balance determines one of the most important quantities in relation to the place of installation. The results are displayed with the balance's accuracy.

### Preparation

- Turn on the balance:  
Press **ON**
- > The Sartorius logo is displayed
- > The balance performs a self-test
- Select reproTEST in the Setup menu: Press **SETUP**
- Select the Balance menu:  
Press the **Menu** soft key
- Select either **reproTEST** or **Selection mode** (factory setting): see "Configuring the Balance"
- Exit the Setup menu:  
Press **<<** soft key

### Check the Reproducibility of the Balance

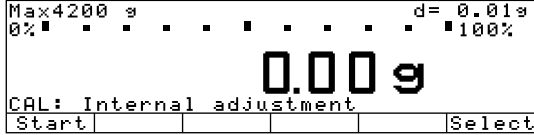
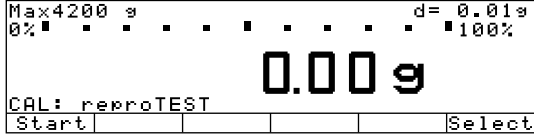
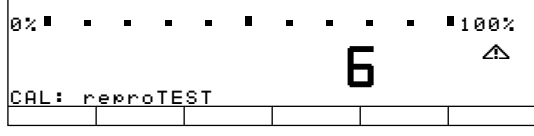
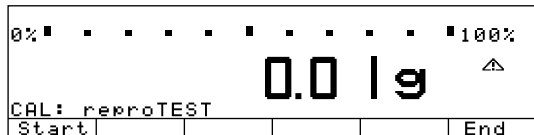
Step	Key(s) (or instruction)	Display/Output
1. If <b>reproTEST</b> is set: and proceed with step 4.  If <b>Selection mode</b> is set:	<b>Cal</b> soft key  <b>Cal</b> soft key	
2. Select reproTEST	<b>Select</b> soft key	
3. Start reproTEST	<b>Start</b> soft key	
4. Number of measurements is displayed; 6 measurements will now be performed		
The standard deviation is displayed		
5. End reproTEST or restart reproTEST	<b>End</b> soft key <b>Start</b> soft key	

## Application Programs

Using Verified Balances as Legal Measuring Instruments in the EU\*:

All application programs can be selected on balances verified for use in legal metrology. Calculated values can be indicated as follows:

- Percent = %
- Piece counting (Counting) = pcs
- Computed value = o, 

### Soft Key Functions

**Start** Start application program

**Weigh.** Toggle to basic weighing functions

### Toggle between Two Weight Units R1 R2

#### Purpose

With this application program you can switch the display of a weight value back and forth between two weight units by pressing a soft key.

You can use the "Toggle between Two Weights" application in combination with a program chosen from Application 2 (checkweighing, time-controlled functions) and one from Application 3 (totalizing, formulation, statistics) as well as with the extra functions.

#### Available Features

- Toggling the displayed weight
- Setting the display accuracy
- Other features as for the basic weighing function

#### Factory Settings

Weight unit 1: **Grams** 

Display accuracy 1:

**All digits**

Weight unit 2: **Grams** 

Display accuracy 2:

**All digits**







\* including the Signatories of the Agreement on the European Economic Area

## Preparation

Balances used as legal measuring instruments: grams and kilograms are the only weight units available

Standard balances: The following weight units are available in both ranges:

Unit	Conversion factor	Display/ Printout	Line for metrological data
Grams	1.000000000000	g	g
Kilograms	0.001000000000	kg	kg
Carats	5.000000000000	ct	ct
Pounds	0.00220462260	lb	lb
Ounces	0.03527396200	oz	oz
Troy ounces	0.03215074700	ozt	ozt
Hong Kong taels	0.02671725000	tlh	tlh
Singapore taels	0.02645544638	tls	tls
Taiwanese taels	0.02666666000	tlt	tlt
Grains	15.43235835000	GN	GN
Pennyweights	0.64301493100	dwt	dwt
Milligrams	1000.000000000000	mg	mg
Parts per pound	1.12876677120	/lb	lb
Chinese taels	0.02645547175	tlc	tlc
Mommes	0.266700000000	mom	M
Austrian carats	5.000000000000	K	K
Tola	0.08573333810	tol	tol
Baht	0.06578947437	bat	bat
Mesghal	0.217000000000	MS	MS

- Turn on the balance: Press 
- > Sartorius logo is displayed, self-test is performed
- Select the "Toggle weight units" program in the Setup menu: Press 
- Select the Application menu: **APP** soft key
- Select **Application 1**:  soft key
- Select **Toggle wt. units**:  or  soft key (repeatedly)
- Confirm **Toggle wt. units**:  soft key
- Select and confirm:
  - **Weight unit 1**: see above
  - **Display accuracy 1**:  
**All digits** or  
**Fewer for weight change** or  
**Last digit off** (for non-verified balances)
  - **Weight unit 2**: see above
  - **Display accuracy 2**:  
**All digits** or  
**Fewer for weight change** or  
**Last digit off** (for non-verified balances)
- see also the "Application Menu (Overview)" in the chapter entitled "Configuring the Balance"
- Save settings and exit the Setup menu: Press the  soft key

## Additional Functions

In addition to the functions for:

- alphanumeric input,
- taring (not during alphanumeric input),
- printing (NUM print; S ID),

you can also access the following functions from this application:

- calibration (not during alphanumeric input),
- toggling to the next application (e.g., checkweighing),
- setup,
- turning off the balance.

## Calibration/Adjustment

- Press the **Cal** soft key
- > See "Calibration/Adjustment" for further instructions

## Toggling to the Next Application

- Press 
- > See the section on the corresponding application program for further instructions

## Setup (setting parameters)

- Press 
- > See "Configuring the Balance" for further instructions

## Turning Off the Balance



- Press 
- > The balance shuts off
- > The display goes blank, then OFF/Standby is displayed with backlighting.

## Practical Example

Toggle the Display From Grams [g] (1st Unit) to Troy Ounces [ozt] (2nd Unit)

Settings (changes in the factory settings required for this example):

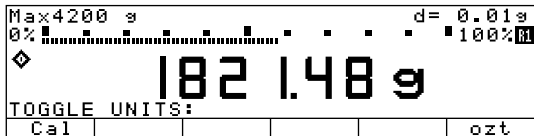
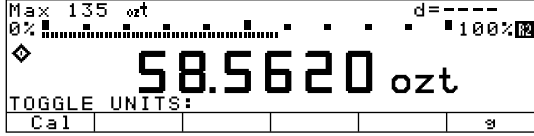
Setup: App: Application 1: Toggle wt. units: Weight unit 2: Troy ounces /ozt

Step	Key (or instruction)	Display/Output
1. Toggle back to weight unit 1, if necessary (R1: Weight unit 1)		 <p>Max 4200 g d= 0.01g 0% 100% R1 182.148 g TOGGLE UNITS: Cal ozt</p>
2. Change weight unit to Troy ounces [ozt] (R2: Weight unit 2)	ozt soft key	 <p>Max 135 ozt d=---- 0% 100% R2 58.5620 ozt TOGGLE UNITS: Cal g</p>
3. Change weight unit to Grams [g]		

## Counting

### Purpose

With the Counting program you can determine the number of pieces of approximately equal weight.

You can use this application program in combination with a program chosen from Application 2 (checkweighing, time-controlled functions) and one from Application 3 (totalizing, formulation, statistics) as well as with the extra functions.

### Features

- Optional balance configuration in Setup for automatically initializing this application and loading the most recent reference sample quantity “nRef” and average piece weight “wRef” when you switch on the balance (this is the automatic setting when the balance is initialized; Setup menu: Application parameters: Auto-start app. when power goes on: On)
- Reference sample quantity “nRef” entered manually
- Average piece weight “wRef” entered manually
- Storage of the current weight value for the preset reference sample quantity “nRef”, to be loaded when the Counting program is initialized
- Setting the accuracy when the reference sample weight “wRef” is stored for calculating a piece count
- Automatic output of the quantity and sample weight via the data interface port after initialization or reference sample updating while running the Counting program (Select Setup: App: Basic settings: Printout configuration: Auto print upon initialization: All values)
- Toggling between piece count and weight value by pressing the **Count.** or **Weigh.** soft key
- Toggling between counting and additional applications using the  key (for example, checkweighing)

### Factory Settings

Accuracy when calculating piece weight: **Display accuracy**

Reference sample updating:  
**Automatic**

### Soft Key Functions

- |               |  |
|---------------|--|
| <b>nRef</b>   | Store value input as reference sample quantity                       |
| <b>wRef</b>   | Store input value as reference sample weight                         |
| <b>Opt.</b>   | Reference updating criteria met; reference updating can be performed |
| <b>Count.</b> | Toggle to the Counting application                                   |

## Preparation

To calculate a piece count, the average weight of one piece must be known. This average piece weight can be entered into the Counting program in one of three ways:

- Enter the average piece weight using the numeric keys and store it;
- The last reference sample quantity entered is loaded and displayed when you turn on the balance. Place the same number of parts on the balance and initialize the Counting program;
- With automatic initialization parameter on (Setup: App: Basic settings: Auto start app when power is switched on: On), the balance goes into the "Counting" mode when you turn it on and loads the last average piece weight and corresponding reference sample quantity that were entered or calculated.

## Reference Sample Updating

You can have the average piece weight updated during counting (with the piece count displayed) if "AWP update" is set to "manual" or "automatic" in the Setup menu. Manual updating can only be performed when the **Update** soft key is displayed. Reference sample updating must be completed before using an application program from Application 3.

The **Update** soft key is displayed when:

- the balance has reached stability (stability symbol displayed)
- the current piece count is less than double the original piece count
- the current piece count is less than 100
- the internally calculated piece count (e.g., 17.24) differs from the nearest whole number (here: 17) by less than 0.3

Reference updating can be repeated several times with an approximately doubled piece count.

- To perform reference updating: Press the **Update** soft key

- Turn on the balance: Press **II/O**

> Sartorius logo is displayed

- Select the Counting program in the Setup menu: Press **SETUP**

- Select the Application menu: Press the **APP** soft key

- Select **Application 1: >** soft key

- Select **Counting: ^** or **v** soft key, repeatedly

- Confirm **Counting: >** soft key

- Select and confirm:

- **Average piece weight calculation**  
**Display accuracy** or **+1 decimal place** or **+2 decimal places**

- **Average piece weight updating:**  
**Off** or **Manual** or **Automatic**

see also the "Application Menu (Overview)" in the chapter entitled "Configuring the Balance"

- Save settings and exit the Setup menu: Press the **<<** soft key

## Additional Functions

In addition to the functions for:

- alphanumeric input,
- taring (not during alphanumeric input),
- printing,

you can also access the following functions from this application:

### Calibration/Adjustment

- Press the **Cal** soft key
- > See "Calibration/Adjustment" for further instructions

### Toggle to the Next Application

- Press **↔**
- > See the section on the corresponding application program for further instructions

### Setup (setting parameters)

- Press **SETUP**
- > See "Configuring the Balance" for further instructions

### Turning Off the Balance

- Press **II/O**
- > The balance shuts off
- > The display goes blank, then OFF or Standby is displayed with backlighting



## Weighing in Percent %

### Purpose

This application program allows you to obtain weight readouts in percent which are in proportion to a reference weight.

Alternatively, you can have the value displayed as a difference in percent between the weight on the balance and the reference weight, or as a special ratio1 or ratio2.

You can use the "Weighing in Percent" application in combination with a program chosen from Application 2 (checkweighing, time-controlled functions) and one from Application 3 (totalizing, formulation, statistics) as well as with the extra functions.

### Available Features

- Reference percentage "pRef" loaded from long-term memory when you turn on the balance
- Optional balance configuration in Setup for automatically initializing this application and loading the most recent reference percentage "pRef" entered with reference weight "Wxx%" when you turn on the balance (Setup: App: Basic settings: Auto start app when power is switched on: On).
- Value displayed as:
  - Residual quantity (portion)
  - Difference (deviation)
  - Ratio1
  - Ratio2
 depending on the selected Setup menu code.
- Reference percentage "pRef" entered manually
- Store the current weight as the reference percentage weight "Wxx%" for initializing the weighing-in-percent application program
- Reference weight "Wxx%" entered manually
- Storage parameter (rounding-off factor) for storing the reference weight "W100%" in percentage calculation can be configured
- Configuration of decimal places displayed with a percentage
- Optional configuration for having the reference weight "Wxx%" and reference percentage automatically output via the data interface port after initialization (print application parameters) (Select Setup: App: Basic settings: Printout configuration: Auto print upon initialization: On, all values)
- Toggle the display between percentage and weight readout by pressing the **Weigh.** or **Perc.** soft key
- Toggle between the weighing-in-percent program and other applications (e.g., checkweighing) by pressing 

### Factory Settings

Storage parameter:

**Display accuracy**

Digits displayed with percentage:

**2 digits**

Display calculated value:

**Residue**

### Soft Key Functions

- |               |   |
|---------------|---|
| <b>pRef</b>   | Store value input as reference percentage     |
| <b>Wxx%</b>   | Store input value as reference sample weight  |
| <b>Perc.</b>  | Toggle to the Weighing-in-percent application |
| <b>Restar</b> | Start next weighing operation                 |

## Preparation

To calculate a value in percent, the reference percentage must be known. This value can be entered into the weighing-in-percent program in one of three ways:

- The last reference percentage entered is loaded and displayed when you turn on the balance. Place the corresponding weight on the balance and initialize the weighing-in-percent program;
- With automatic initialization switched on (Setup: App: Basic settings: Auto start app when power is switched on: On), the balance goes into the "weighing in percent" mode when you turn it on and loads the last reference percentage entered as well as the corresponding reference weight;
- Enter the reference weight using the numeric keys and store it (**Wxx%** soft key).

- Turn on the balance: Press **I/O**
- > Sartorius logo is displayed
- Select the Weighing in percent application in the Setup menu: Press **SETUP**
- Select the Application menu: **APP** soft key
- Select **Application 1: >** soft key
- Select **Percent weigh.: ^** or **v** soft key repeatedly
- Confirm **Percent weigh.: >** soft key
- Select and confirm:
  - **Weight storage accuracy:**  
**Display accuracy** or  
**+1 decimal place** or  
**+2 decimal places**
  - **Decimal places for readout in pct.:**  
**None** or  
**1 decimal place** or  
**2 decimal places** or  
**3 decimal places** or  
**4 decimal places** or  
**5 decimal places** or  
**6 decimal places**
  - **Display calculated value:**  
**Residue** or  
**Loss** or  
**Ratio1 (DR)** or  
**Ratio2 (OR)** or
- see also the "Application Menu (Overview)" in the chapter entitled "Configuring the Balance"
- Save settings and exit the Setup menu: Press the **<<** soft key

## Equations

The following equations are used for the corresponding calculations:

$$\text{Residue} = \text{Current weight} \div 100\% \text{ weight} \times 100\%$$

$$\text{Loss} = (\text{Current weight} - 100\% \text{ weight}) \div 100\% \text{ weight} \times 100\%$$

$$\text{Ratio1} = (100\% \text{ weight} - \text{current weight}) \div \text{current weight} \times 100\%$$

$$\text{Ratio2} = 100\% \text{ weight} \div \text{current weight} \times 100\%$$

## Additional Functions

In addition to the functions for:

- alphanumeric input,
- taring (not during alphanumeric input),
- printing,

you can also access the following functions from this application:

### Calibration/Adjustment

- Press the **Cal** soft key
- > See "Calibration/Adjustment" for further instructions

### Toggle to the Next Application

- Press **↔**
- > See the section on the corresponding application program for further instructions

### Setup (setting parameters)

- Press **SETUP**
- > See "Configuring the Balance" for further instructions

### Turning Off the Balance

- Press **I/O**
- > The balance shuts off
- > The display goes blank, then OFF/Standby is displayed with backlighting

## Examples

Practical Example P1: Weighing in Percent with Reference Weight Taken From Weight on Balance

Settings (changes in the factory settings required for this example):

Setup: App: Application 1: Weighing in percent

Setup: App: Basic settings: Printout configuration: Auto print upon initialization: On, all values

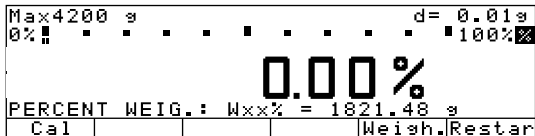
Step	Key (or instruction)	Display/Output
1. Delete previous setting if necessary	<b>[CF]</b>	
2. Prepare a container for the parts	Place the empty container on the balance	 <p>Max4200 g d= 0.01g 0% 100% + 50.06 g PERCENT WEIG.: pRef = 100 % Cal Start</p>
3. Tare the balance	<b>[TARE]</b>	 <p>Max4200 g d= 0.01g 0% 100% + 0.00 g PERCENT WEIG.: pRef = 100 % Cal Start</p>
4. Place the reference weight on the balance (here: 1821.48 g = 100%)	Place weight equal to reference weight in the container	 <p>Max4200 g d= 0.01g 0% 100% + 1821.48 g PERCENT WEIG.: pRef = 100 % Cal Start</p>
5. Initialize the balance	<b>Start</b> soft key	 <p>Max4200 g d= 0.01g 0% 100% + 100.00 % PERCENT WEIG.: Wxx% = 1821.48 g Cal Weigh. Restar</p> <p>pRef + 100 % Wxx% + 1821.48 g</p>
6. Unload the balance	Remove reference sample from the container	 <p>Max4200 g d= 0.01g 0% 100% + 0.00 % PERCENT WEIG.: Wxx% = 1821.48 g Cal Weigh. Restar</p>
7. Determine the percentage of an unknown weight	Place sample to be measured in the container	 <p>Max4200 g d= 0.01g 0% 100% + 98.37 % PERCENT WEIG.: Wxx% = 1821.48 g Cal Weigh. Restar</p>
8. If desired, print percentage	<b>[Ⓞ]</b>	 <p>Prc + 98.37 %</p>

(here: 98.37%)

Practical Example P2: Weighing in Percent with Reference Weight Entered Using the Numeric Keys

Settings (changes in the factory settings required for this example):

Setup: App: Application 1: Weighing in percent

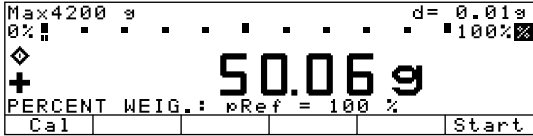
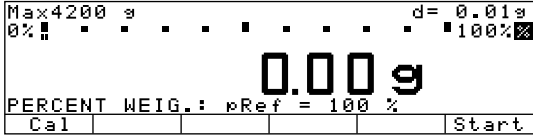
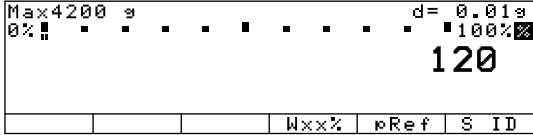
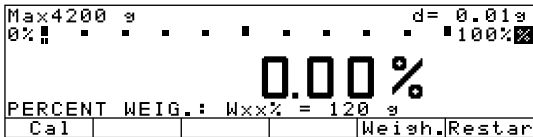
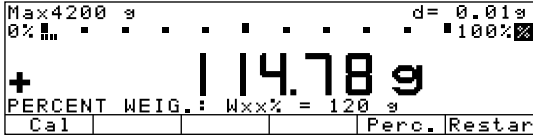
Step	Key (or instruction)	Display/Output
1. Delete previous setting if necessary	<b>CF</b>	
2. Prepare a container for the parts	Place the empty container on the balance	
3. Tare the balance	<b>TARE</b>	
4. Enter the reference weight using the numeric keys (here: 120 g)	<b>1 2 0</b>	
5. Store the reference weight	<b>Wxx%</b> soft key	
6. Determine the percentage of an unknown weight	Place sample to be measured in the container (in the case: 114.78 g)	
7. Toggle to weight display	<b>Weigh.</b> soft key	

## Animal Weighing

### Purpose

Use this program to determine the weights of unstable samples (e.g., live animals) or to determine weights under unstable ambient conditions. In this program, the balance calculates the weight as the average of a defined number of individual weighing operations. These weighing operations are also known as "subweighing operations."

You can use the "Animal Weighing" application in combination with a program chosen from Application 2 (checkweighing, time-controlled functions) and one from Application 3 (totalizing, formulation, statistics) as well as with the extra functions.

### Available Features

- Animal weighing started manually or automatically
- Automatic start:
  - when a defined threshold has been exceeded (Minimum load threshold: 10; 20; ...; 500; 1,000 display increments)
  - when three successive sub-weights lie within a user-defined tolerance range (calm; normal; active; 0.1%; 0.2%; ...; 50%; 100% of the animal/object)
- Manual start:
  - also possible when the load is under the minimum load threshold
  - when three successive sub-weights lie within a user-defined tolerance range (calm; normal; active; 0.1%; 0.2%; ...; 50%; 100% of the animal/object)

- Optional balance configuration in the Setup menu for automatically initializing this application when you turn on the balance
- Number of weighing operations for calculation of an average (**mDef**) can be entered before the beginning of each animal weighing operation
- The factor for calculation of the result can be entered before the beginning of each animal weighing operation
- The number of subweighs remaining to be performed is indicated in the text display during weighing
- Arithmetic average displayed as a result in the pre-set weight unit (identified by the  symbol).
- Optional multiplication of the arithmetic average by a user-defined factor **Mu1**. A circle "o" is displayed as weight unit and **Mu1 = xxx** is shown in the text line
- Toggling between the animal weight and the calculated value by pressing the **xNet** soft key and the **xRes** soft key
- Automatic output of results via the interface port:
  - Number of weighing operations **mDef**
  - Multiplication factor **Mu1**
- Automatic output of results (printout) via the interface port:
  - Weighing result **xNet**
  - Calculated result **xRes**

The following options have to be selected: Setup: Basic settings: Printout configuration: Auto print upon initialization: On, all values
- The unload threshold is equal to one-half the minimum balance capacity
- Return to weighing mode by unloading the balance; i.e., when the load is below the unload threshold

### Factory Settings

Animal activity: **5% of the animal/object**  
 Start: **Automatic**  
 Minimum load for automatic storage: **100 display increments**  
 Decimal places in result display: **2 decimal places**  
 Printout: **Average weight only**

### Soft Key Functions

**New** Automatic start:  
 - Unload balance and weigh next animal, if desired  
 - Press key to start next subweigh  
 Manual start:  
 Start next subweigh

**mDef** Store user-defined number of subweighs for averaging

**Mu1** Store user-defined factor as multiplication factor for calculated the arithmetic mean

**xNet** Toggle to the animal weight

**xRes** Toggle to the calculated animal weighing result

### Printout for Animal Weighing

Upon completion of the averaging process, you can have the results printed out automatically. You can also have both the weight and the calculated result printed.



```

mDef          10
Mu1           0.347
xNet  +153.00 g
xRes   +  5.30 o
    
```

mDef: Numbers of subweighing operations for averaging

Mu1: Multiplication factor

## Preparation

- Turn on the balance: Press 
- > Sartorius logo is displayed
- Select the Animal weighing application in the Setup menu: Press 
- Select the Application menu: **APP** soft key
- Select **Application 1: >** soft key
- Select **Animal weigh.:** **↕** or **↘** soft key repeatedly
- Confirm **Animal weigh.:** **>** soft key
- Select and confirm:
  - **Animal activity:**  
Calm or  
Normal or  
Active or  
0.1% of animal/object or  
0.2% of animal/object or  
0.5% of animal/object or  
1% of animal/object or  
2% of animal/object or  
5% of animal/object or  
10% of animal/object or  
20% of animal/object or  
50% of animal/object or  
100% of animal/object
  - **Start:**  
Manual mode or  
Automatic mode
  - **Minimum load for automatic storage:**  
None or  
10 display increments or  
20 display increments or  
50 display increments or  
100 display increments or  
200 display increments or  
500 display increments or  
1,000 display increments
  - **Decimal places in result display:**  
None or  
1 decimal place or  
2 decimal places or  
3 decimal places or  
4 decimal places or  
5 decimal places or  
6 decimal places
  - **Printout:**  
None or  
Average weight only or  
Average and calculated value
- see also the "Application Menu (Overview)" in the chapter entitled "Configuring the Balance"
- Save settings and exit the Setup menu: Press the **<<** soft key

## Additional Functions

In addition to the functions for:

- alphanumeric input,
- taring (not during alphanumeric input),
- printing,

you can also access the following functions from this application:

### Calibration/Adjustment

- Press the **Cal** soft key
- > See "Calibration/Adjustment" for further instructions

### Toggle to the Next Application

- Press 
- > See the section on the corresponding application program for further instructions

### Setup (setting parameters)

- Press 
- > See "Configuring the Balance" for further instructions

### Turning Off the Balance

- Press 
- > The balance shuts off
- > The display goes blank, then OFF/Standby is displayed with backlighting

## Practical Example

Determining Animal Weight With Automatic Start of 20 Subweighing Operations for Averaging; Automatic Printout of the Number of Subweighing Operations and of the Animal Weight

Settings (changes in the factory settings required for this example):

Setup: App: Application 1: Animal weighing: Animal activity: Active

Setup: App: Application 1: Animal weighing: Printout: Average and calculated values

Setup: App: Basic settings: Printout configuration: Auto print upon initialization: On, all values

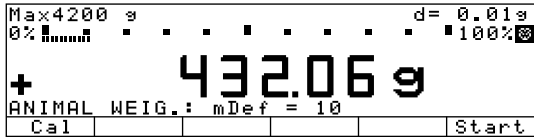
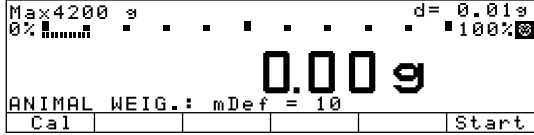
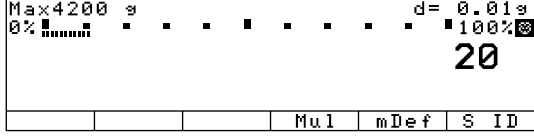
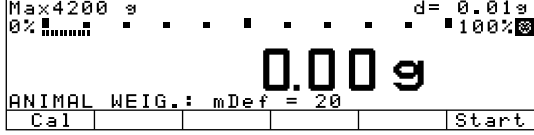
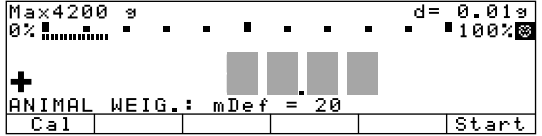
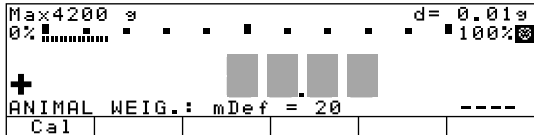
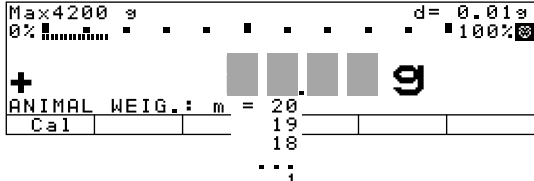
Step	Key (or instruction)	Display/Output
1. Delete previous setting if necessary	<b>CF</b>	
2. Prepare a container (cage)	Place empty cage on the balance	 <p>Max4200 g d= 0.01g 0% 100% + 432.06 g ANIMAL WEIG.: mDef = 10 Cal Start</p>
3. Tare the balance	<b>TARE</b>	 <p>Max4200 g d= 0.01g 0% 100% 0.00 g ANIMAL WEIG.: mDef = 10 Cal Start</p>
4. Enter number of subweighing operations for averaging	<b>2</b> <b>0</b>	 <p>Max4200 g d= 0.01g 0% 100% 20 Mul mDef S ID</p>
5. Save number	<b>mDef</b> soft key	 <p>Max4200 g d= 0.01g 0% 100% 0.00 g ANIMAL WEIG.: mDef = 20 Cal Start</p>
6. Weigh the first animal	Place 1st animal in cage	weight value fluctuates due to animal activity  <p>Max4200 g d= 0.01g 0% 100% + ANIMAL WEIG.: mDef = 20 Cal Start</p>
7. Start automatic animal weighing	<b>Start</b> soft key	 <p>Max4200 g d= 0.01g 0% 100% + ANIMAL WEIG.: mDef = 20 Cal Start</p>
The balance delays starting the subweighing operation until three successive subweights lie within the range defined for an "active" animal	When this criterion is met, the subweighing series begins	 <p>Max4200 g d= 0.01g 0% 100% + ANIMAL WEIG.: m = 20 Cal 19 18 1 1</p>

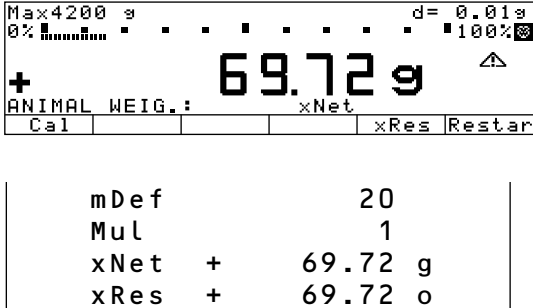
Step	Key (or instruction)	Display/Output												
<p>After 20 subweighing operations the arithmetic average (xNet) is display  <b>mDef</b>: no. of subweighs  <b>Mul</b>: calculation factor  <b>xNet</b>: arithm. average, net value  <b>xRes</b>: calculated value)</p>		 <p>Max4200 g d= 0.01g  0% 100%  + 69.72 g  ANIMAL WEIG.: xNet  Cal xRes Restar</p> <table border="1"> <tr><td>mDef</td><td></td><td>20</td></tr> <tr><td>Mul</td><td></td><td>1</td></tr> <tr><td>xNet</td><td>+</td><td>69.72 g</td></tr> <tr><td>xRes</td><td>+</td><td>69.72 o</td></tr> </table>	mDef		20	Mul		1	xNet	+	69.72 g	xRes	+	69.72 o
mDef		20												
Mul		1												
xNet	+	69.72 g												
xRes	+	69.72 o												

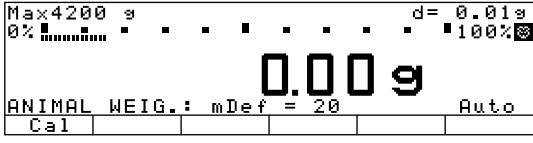
8. Unload the balance	Remove animal from cage	 <p>Max4200 g d= 0.01g  0% 100%  0.00 g  ANIMAL WEIG.: mDef = 20 Auto  Cal</p>
-----------------------	-------------------------	--

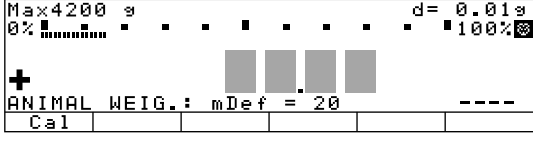
9. If desired, weigh next animal	Place animal in cage	 <p>Max4200 g d= 0.01g  0% 100%  + ANIMAL WEIG.: mDef = 20  Cal</p>
----------------------------------	----------------------	--

Next weighing series begins automatically		 <p>Max4200 g d= 0.01g  0% 100%  + ANIMAL WEIG.: m = 20  Cal 19 18 ... 1</p>
---	--	--

## Recalculation

### Purpose

With this application program you can compensate for over-poured components in formulation.

If a component is over-poured when weighing in the individual formulation components, the mixture already poured cannot be used in its current composition. To avoid having to discard the materials weighed, you can adjust the proportions of the formulation to compensate for the over-pour.

When you use this application, the recalculation procedure is mainly performed by the scale.

You can use the "Recalculation" application in combination with a program chosen from Application 2 (checkweighing, time-controlled functions) and one from Application 3 (totalizing, formulation, statistics) as well as with the extra functions.

### Available Features

- Individual components (up to 99) weighed in with a readout showing from "0" to the desired component weight
- Transaction counter shows the next component expected
- Weighed components are stored, followed by automatic printout and taring
- Additive weighing of components with printout
- Toggle the display between component weight and total formulation weight (additive mode) after first component is stored
- Stored component weight displayed as true net weight for 2 seconds
- Enter a divisor before or during component weighing. For example, if the formulation has a total weight of 100 g, enter the divisor 10 to weigh in a total formulation of 1,000 g.
- If a component is over-poured, you can use the recalculation function to change the amount of this component indicated in the formulation by using plus or minus keys or numeric input. The balance calculates a factor by which all other component amounts will then be adjusted according to the desired component value.
- Recalculation factor displayed in the text line, with a warning symbol if the factor is not equal to 1.
- All components displayed with number and the amount (by weight) to be added in follow-on filling. Components displayed in sequence by the scale.
- Display of actual net weight during follow-on filling
- After the amounts of the components already weighed have been corrected, weighing continues according to the adjusted formulation amount. The readout is recalculated (updated) according to the divisor.
- You can repeat the over-pour correction procedure as often as necessary, in case other components are over-poured.
- After follow-on (corrective) filling, the total amount differs from that given for the formulation, but the proportion of components in relation to each other is the same.
- You can have the weight printed after each measurement
- Individual component weights are printed as "Compxx."
- Press **[CF]** to exit the application program. The component memory is cleared and the sum of components printed as "S-Comp."
- Toggle between the recalculation program and other applications (e.g., checkweighing) by pressing **[D]**.

## Factory Settings

Print application parameters (automatic output of application parameters): **ALL VALUES (7 1 1)**

Printout configuration:

Line format: **For other APPS: GLP (7 2 2)**

## Soft Key Functions

<b>Comp.xx</b>	Store component
<b>Add.xx</b>	Store component in additive weighing mode
<b>Div.</b>	Store divisor before or during component weighing
<b>Recalc</b>	Start correction procedure for recalculation
<b>→Add./Comp.</b>	Toggle display between component weight and total weight (additive mode)
<b>Comp.</b>	Store numeric input for recalculation
<b>Minus</b>	Set value given for the formulation
<b>Plus</b>	Set value given for the formulation

## Preparation

- Turn on the balance: Press **[I/O]**
  - > Sartorius logo is displayed
- Select the Recalculation application in the Setup menu: Press **[SETUP]**
- Select the Application menu: Press **APP** soft key
- Select **Application 1: >** soft key
- Select **Recalculation: ^** or **v** soft key repeatedly
- Confirm **Recalculation: <** soft key
- Save settings and exit the Setup menu: Press the **<<** soft key

## Additional Functions

In addition to the functions for:

- alphanumeric input,
- taring (not during alphanumeric input), and
- printing,

you can also access the following functions from this application:

### Calibration/Adjustment

- Press the **Cal** soft key
  - > See “Calibration/Adjustment” for further instructions

### Toggling to the Next Application

- Press **[↔]**
  - > See the section on the corresponding application program for further instructions

### Setup (setting parameters)

- Press **[SETUP]**
  - > See “Configuring the Balance” for further instructions

### Turning Off the Balance

- Press **[I/O]**
  - > The balance shuts off
  - > The display goes blank, then OFF/Standby is displayed with backlighting







## Practical Example

When weighing in formulation components, the second component is over-poured.

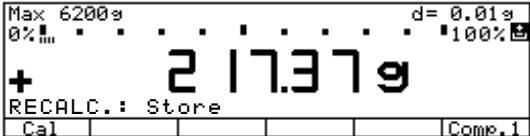

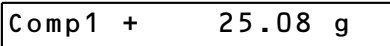
Settings (changes in the factory settings required for this example):

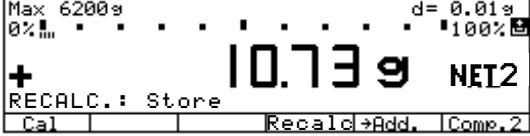
Setup: App: Application 1: Recalculation

Setup: App: Basic settings: Printout configuration: Auto print upon initialization: On, only main values

Step	Key (or instruction)	Display/Output
1. Delete previously stored values, if necessary	<b>CF</b>	
2. Place container for filling components on the balance	Place empty container on the balance	
3. Tare	<b>TARE</b>	
4. Add the first component	Weigh the first component into the container	
5. Store component	Press the <b>Comp. 1</b> soft key	 
6. Add the second component	Weigh the second component into the container	
7. Start recalculation, because 10.73 g were poured rather than 10.60 g	<b>Recalc</b> soft key	
8. Either press the minus key to correct the value ...	<b>Minus</b> soft key repeatedly	

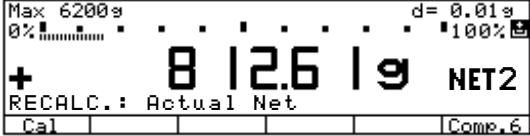
Step	Key (or instruction)	Display/Output
... or enter the desired value	1 0 . 6 0	
9. Confirm the new value	Comp. soft key	
Follow-on filling amount for first component is displayed		
10. Follow-on filling of 1st component and store	Weigh the first component up to 0 Comp. 1 soft key	
The true net value is displayed for 2 seconds		
11. Weigh in further components, if called for in the formulation	Repeat steps 4 and 5 as needed	
12. Toggle to the additive mode, if required	→Add. soft key	
13. Add further components, as required ... (here, e.g., up to the total weight of the formulation: 1,000 g)	Add components to container	

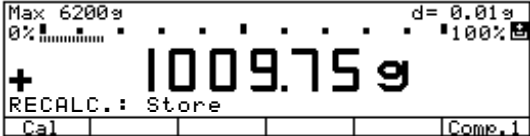
Step	Key (or instruction)	Display/Output
14. ... and store (here, e.g., the 6th component)	<b>Add. 6</b> soft key	<pre> Comp1 + 25.08 g Comp2 + 10.73 g R.div.+ 1.01226 RCom1 + 25.39 g Comp3 + 22.03 g Comp4 + 31.49 g Comp5 + 107.50 g Comp6 + 812.61 g           </pre>
The true net value (of the 6th component) is displayed for 2 seconds		 <p>Max 6200g d= 0.01g 0% 100% + 812.61g NET2 RECALC.: Actual Net Cal Comp. 6</p>
Then the total weight is displayed		 <p>Max 6200g d= 0.01g 0% 100% + 1000.00g NET2 RECALC.: Store Cal Recalc → Comp. Add. 7</p>
15. End the weighing procedure Total weight is printed	<b>CF</b>	<pre> Comp1 + 25.08 g Comp2 + 10.73 g R.div.+ 1.01226 RCom1 + 25.39 g Comp3 + 22.03 g Comp4 + 31.49 g Comp5 + 107.50 g Comp6 + 812.61 g Tot.cp+ 1009.75 g           </pre>
Total weight is displayed Component memory is cleared		 <p>Max 6200g d= 0.01g 0% 100% + 1009.75g RECALC.: Store Cal Comp. 1</p>



## Calculation

### Purpose

With this application program you can calculate a weight value using an algebraic equation. This can be used, for example, to determine the gsm weight (grams per square meter) of paper.

You can use the "Calculation" application in combination with a program chosen from Application 2 (checkweighing, time-controlled functions) and one from Application 3 (totalizing, formulation, statistics) as well as the extra functions.

### Available Features

- You can store an equation and configure the Setup menu to initialize this program automatically with the stored equation (Setup: App: Basic settings : Auto start upon initialization: On)
- The  symbol is displayed to indicate a calculated value. The equation used is displayed in the text line
- If no equation was entered, the weight value is displayed
- Toggle between the weight readout, equation input and display of the calculated result by pressing the corresponding soft keys (or press  to toggle between weight and calculated value)
- There are four operators (+, -, \*, /) and one factor (weight value) available when you enter an equation
- Max. equation length: 28 characters
- Pressing  will delete either the equation or the last character entered, depending on the configuration in the Setup menu (Setup: App: Basic settings: Keypad: CF function for input: Delete last character)
- The calculated result is displayed with the number of decimal places configured in the Setup menu. Not all decimal places are displayed if the result is longer than the display allows. If there are more digits before the decimal point than the display can show, an error message is displayed.
- The equation is stored in non-volatile memory



### Factory Settings

Decimal places in calculated result:  
**2 decimal places**

### Soft Key Functions

<b>Equat.</b>	Toggle to equation
<b>+</b>	Enter an addition operator in the equation
<b>-</b>	Enter a subtraction operator in the equation
<b>*</b>	Enter a multiplication operator in the equation
<b>/</b>	Enter a division operator in the equation
<b>Weight</b>	Enter a weight value in the equation
<b>Start</b>	Start calculation
<b>Weigh</b>	Toggle to the weighing mode

## Preparation

- Turn on the balance: Press 
- > Sartorius logo is displayed, self-test is performed
- Select the Calculation application program in the Setup menu: Press 
- Select the Application menu: **APP** soft key
- Select **Application 1: >** soft key
- Select **Calculation: ^** or **v** soft key repeatedly
- Confirm **Calculation: >** soft key
- Select and confirm:
  - **Decimal places in calculated result:**  
**None** or  
**1 decimal place** or  
**2 decimal places** or  
**3 decimal places** or  
**4 decimal places** or  
**5 decimal places** or  
**6 decimal places**
- see also the "Application Menu (Overview)" in the chapter entitled "Configuring the Balance"
- Save settings and exit the Setup menu: Press the **<<** soft key

## Additional Functions

In addition to the functions for:

- alphanumeric input,
- taring (not during alphanumeric input),
- printing,

you can also access the following functions from this application:

### Calibration/Adjustment

- Press the **Cal** soft key
- > See "Calibration/Adjustment" for further instructions

### Toggle to the Next Application

- Press 
- > See the section on the corresponding application program for further instructions

### Setup (setting parameters)

- Press 
- > See "Configuring the Balance" for further instructions

### Turning Off the Balance





- Press 
- > The balance shuts off
- > The display goes blank, then OFF/Standby is displayed with backlighting

## Practical Example

Calculate the gsm weight of paper: determine the gsm of a sheet of A4 paper with the dimensions  $0.210\text{ m} \times 0.297\text{ m} = 0.06237\text{ m}^2$ . The gsm weight is a product of the division of the weight by the surface area.

Settings (changes in the factory settings required for this example):

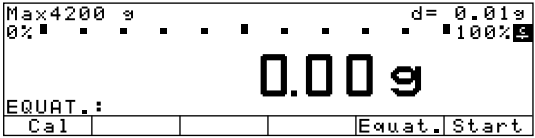
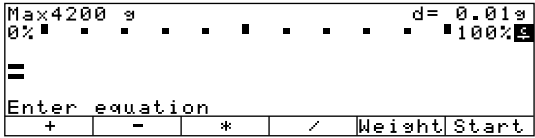
Setup: App: Application 1: Calculation

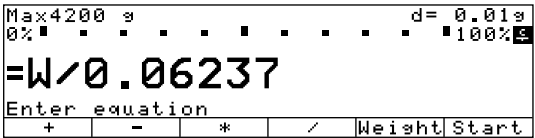
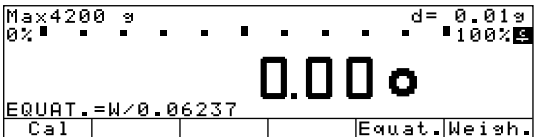
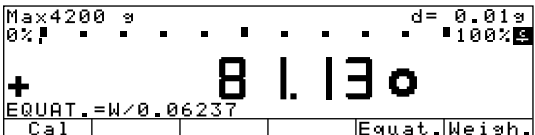
Step	Key (or instruction)	Display/Output
1. Turn on the balance and configure the settings as indicated above		
2. Delete previous setting if necessary		
3. Tare the balance		
4. Select equation input	<b>Equat.</b> soft key	
5. Enter weight value Enter division sign Enter the surface area of a sheet of A4 paper	<b>Weight</b> soft key / soft key 	
6. Turn on the calculated result display	<b>Start</b> soft key	
7. Determine the gsm weight	Place A4 sheet on the balance	

## Density Determination

### Purpose

With this application you can determine the density and volume of solid, pasty, liquid or powdered samples.

You can use the "Density Determination" application in combination with a program chosen from Application 2 (e.g., checkweighing, timer functions) and one from Application 3 (totalizing, formulation, statistics) as well as the extra functions.

### Available Features

- Choose from 2 methods for determining density of solids:
  - Buoyancy, or

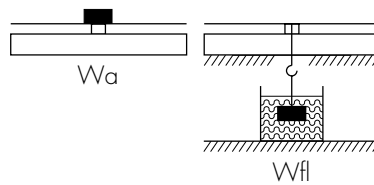

- displacement.

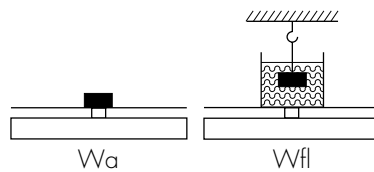

- Density determination on pasty or powdered samples using the pycnometer method

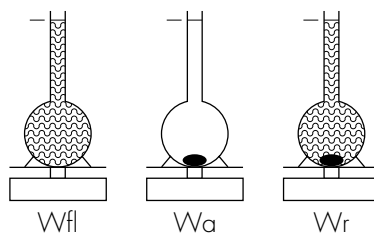

- Density determination on liquids using the liquid density method
- Choice of liquids for buoyancy:
  - Water
  - Ethanol
  - Other liquids (user-definable)
- Reference values can be entered using the numeric keys
  - Weight of sample in air ( $W_a$ )
  - Weight of sample in liquid, or weight of reference liquid when using the pycnometer ( $W_{fl}$ )
  - Weight of sample and reference liquid when using the pycnometer ( $W_r$ )
- Long-term storage of parameters:
  - Temperature
  - Buoyancy correction
  - Air density
  - Density of reference liquid
  - Expansion coefficient
  - Plummets volume

### Factory Settings

Method: **Buoyancy**

Liquid causing buoyancy: **Water**

No. of decimals for display of vol. density: **2 decimals**

Printout: **None**

### Soft Key Assignments

- W<sub>a</sub>** Store weight of sample in air
- W<sub>fl</sub>** With liquid density, buoyancy and displacement methods:
  - Store weight of sample in liquid
  - With pycnometer method:
    - Store weight of reference liquid
- W<sub>r</sub>** With pycnometer method: Store weight of sample and liquid
- Start** Start a new measurement routine
- Param.** Toggle to parameter input mode (depending on method selected)
- Densit.** Display the density (the parameters set remain effective for the next measurement)
- Weigh** Display the weight (the parameters set remain effective for the next measurement)
- Vol.** Display the volume (the parameters set remain effective for the next measurement)

## Equations Used to Determine Density:

Buoyancy:  $\text{Rho} = (\text{Wa} \times (\text{Rho}_{\text{fl}} - \text{LA})) \div ((\text{Wa} - \text{Wfl}) \times \text{Corr}) + \text{LA}$

For the buoyancy method, a factor of 0.99983 (factory setting) is used to allow for the buoyancy caused by the bars of the sample holder of the YDK 01 (LP) Density Determination Kit. This factor is yielded by allowing for this equation:

$$\text{buoyancy of bars} = 2 \times d^2 \div D^2 (\text{Wa} - \text{Wfl})$$

The equation takes the following variables into consideration: the number of wires or bars, the wire/bar diameter of the sample holder, and the inner diameter of the vessel used.

The factor 0.99983 is yielded by  $1 - 2 \times d^2 \div D^2$

where:  $2$  = number of wires/bars  
 $d$  = wire/bar diameter (0.7 mm\*)  
 $D$  = inner diameter of the vessel (76 mm\*)

If you are using different vessels or other density kits, press the **Param.** soft key to enter any necessary changes in this calculation factor.

To determine the density of a solid according to the buoyancy method with our YDK 01 (LP) Density Determination Kit, make sure to use the beaker with a 76 mm diameter.

Displacement:  $\text{Rho} = (\text{Wa} \times (\text{Rho}_{\text{fl}} - \text{LA})) \div (\text{Wfl} \times \text{Corr}) + \text{LA}$

For the displacement method, a factor of 1.00000 (factory setting) is used to allow for the buoyancy caused by a wire suspended in the liquid.

If you are using different vessels or other density kits, press the **Param.** soft key to enter any necessary changes in this calculation factor.

The equation takes the following variables into consideration: the number of wires or bars, the wire/bar diameter of the sample holder, and the inner diameter of the vessel used.

This factor is yielded by:  $\text{Corr} = 1 - \chi \times d^2 \div D^2$

where:  $\chi$  = number of wires  
 $d$  = wire diameter  
 $D$  = inner diameter of the vessel



with:  $\text{Rho}_{\text{fl}}$  = density of the reference liquid  
 $\text{Wa}$  = weight of sample in air  
 $\text{Wfl}$  = weight of the sample in liquid/buoyancy of sample  
 $\text{Corr}$  = correction for buoyancy produced by the immersed wires or bars of the sample holder:  
0.99983 for the buoyancy method  
1 for the displacement method  
 $\text{LA}$  = correction for air buoyancy = 0.0012 g/ccm

Pycnometer:  $\text{Rho} = (\text{Wa} \times (\text{Rho}_{\text{fl}} - \text{LA})) \div (\text{Wfl} + \text{Wa} - \text{Wr}) + \text{LA}$

where:  $\text{Rho}_{\text{fl}}$  = density of the reference liquid  
 $\text{Wa}$  = weight of the sample  
 $\text{Wfl}$  = weight of the reference liquid  
 $\text{Wr}$  = weight of sample + the reference liquid  
 $\text{LA}$  = correction for air buoyancy = 0.0012 g/ccm

\* For the YDK 01 (LP) Density Determination Kit

## Preparation

- Turn on the balance: Press 
- > Sartorius logo is displayed
- Select the Density application in the Setup menu: Press 
- Select the Application menu: **APP** soft key
- **Application 1** Select: **➤** soft key
- Select **Density**: **▲** or **▼** soft key repeatedly
- Confirm **Density**: **➤** soft key
- Select and confirm:
  - **Method:**  
**Density of liquid** or  
**Buoyancy** or  
**Displacement** or  
**Pycnometer**
  - **Liquid causing buoyancy:**  
**Water** or  
**Ethanol** or  
**User-definable**
  - **Decimals for disp. of vol./density:**  
**None** or  
**1 decimal place** or  
**2 decimals places** or  
**3 decimals places** or  
**4 decimals places**
  - **Printout:**  
**None** or  
**All data**
- see also the "Application Menu (Overview)" in the chapter entitled "Configuring the Balance"
- Save settings and exit the Setup menu: Press the **◀◀** soft key

## Additional Functions

In addition to the functions for:

- alphanumeric input,
  - taring (not during alphanumeric input),
  - printing,
- you can also access the following functions from this application:
- calibration (not during alphanumeric input),
  - toggling to the next application (e.g., checkweighing),
  - setup,
  - turning off the balance.

## Calibration/Adjustment

- Press the **Cal** soft key
- > See "Calibration/Adjustment" for further instructions

## Toggling to the Next Application

- Press 
- > See the section on the corresponding application program for further instructions

## Setup (setting parameters)

- Press 
- > See "Configuring the Balance" for further instructions

## Turning Off the Balance

- Press 
- > The balance shuts off
- > The display goes blank, then OFF/Standby is displayed with backlighting

## Practical Example

Buoyancy: Determine the Density of Samples of a Solid Using the Buoyancy Method. Reference Liquid: Water.

Settings (changes in the factory settings required for this example):

Setup: App: Application 1: Density

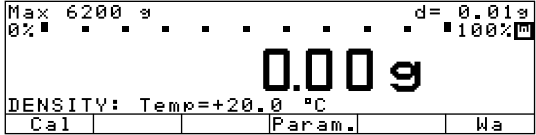
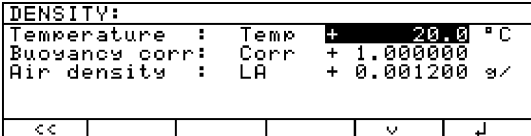
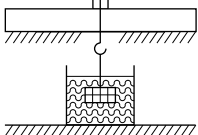
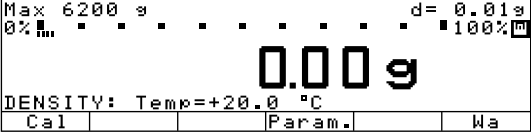
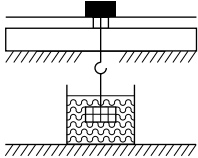
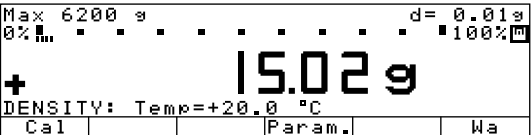
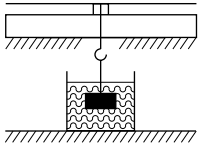
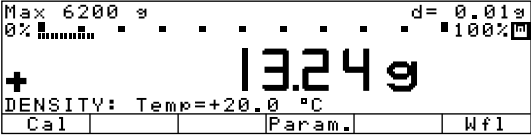
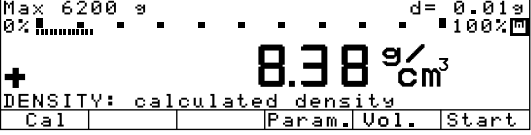
Step	Key (or instruction)	Display/Output
1. Delete previously stored values if necessary	<b>CF</b>	
2. Change configurations, if necessary	<b>Param.</b> soft key	
3. Position the sample holder (immersed)		
4. Tare the balance	<b>TARE</b>	
5. Determine the weight of the sample in air: place sample on the weighing pan		
6. Store weight value	<b>Wa</b> soft key	
7. Determine the weight of the sample in liquid: place sample in the sample holder		
8. Store weight Density of sample is displayed	<b>Wf1</b> soft key	

Step	Key (or instruction)	Display/Output
9. Display volume of sample	<b>Vol.</b> soft key	<p>Max 6200 g d= 0.01g  0% ██████████ 100%  + 1.79 cm<sup>3</sup>  DENSITY: calculated volume  Cal Param. Vol. Start</p>
10. Display weight	<b>Weigh</b> soft key	<p>Max 6200 g d= 0.01g  0% ██████████ 100%  + 13.24 g  DENSITY: buoyancy  Cal Param. Weigh Start</p>
11. Repeat procedure with next sample, if desired	<b>Start</b> soft key	

## Practical Example

Displacement: Determine the Density of Samples of a Solid Using the Displacement Method.

Reference Liquid: Ethylene glycol. Temperature: 23°C (73.4 °F). Set the density at 20°C (68°F) to 1.113 g/cm<sup>3</sup> and the volume expansion coefficient at 20°C (68°F) to 0.00064 grd<sup>-1</sup>.

Settings (changes in the factory settings required for this example):

Setup: App: Application 1: Density: Method: Displacement

Setup: App: Application 1: Density: Liquid for buoyancy: User-definable

Step	Key (or instruction)	Display/Output
1. Delete previously stored values if necessary	<b>CF</b>	
2. Change configurations: Temperature: 23.0 Density of ref. liquid: 1.113 Expansion coefficient: 0.000640	<b>Param.</b> soft key	
3. Place the container with the reference liquid on the balance		
4. Tare the balance	<b>TARE</b>	
5. Determine the weight of the sample in air: place sample on the weighing pan		
6. Store weight value	<b>Wa</b> soft key	
7. Determine the weight of the sample in liquid: place sample in the sample holder		
8. Store weight Density of sample is displayed	<b>Wf1</b> soft key	

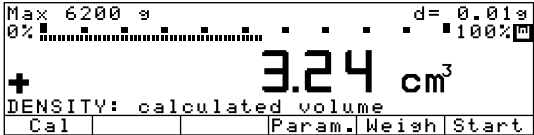
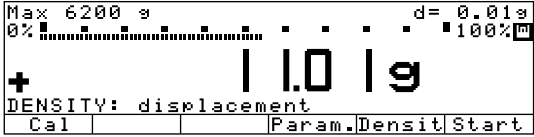
Step	Key (or instruction)	Display/Output
9. Display volume of sample	<b>Vol.</b> soft key	
10. Display weight	<b>Weigh</b> soft key	
11. Repeat procedure with next sample, if desired	<b>Start</b> soft key	

## Practical Example

Sample in a 50-ml Pycnometer. Reference Liquid: Water; Temperature: 22°C (71.6°F)

Pycnometer: Determine the Density of a Granulated Sample



Settings (changes in the factory settings required for this example):

Setup: App: Application 1: Density: Method: Pycnometer

Setup: App: Extra Function (F4): 2nd Tare Memory

Setup: App: Basic Settings: Keypad: CF Function in Application: Clear only selected applications

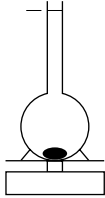
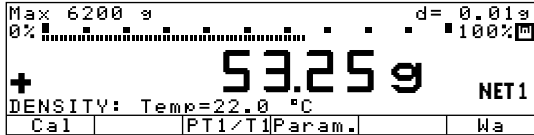
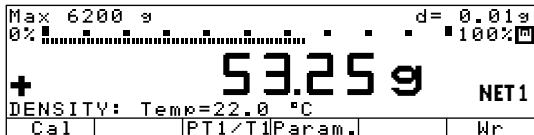
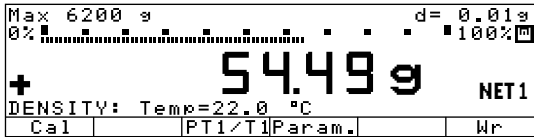
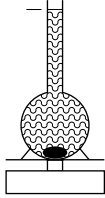
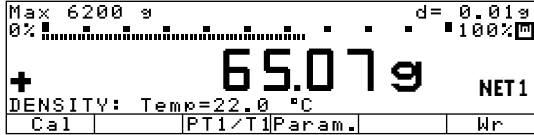
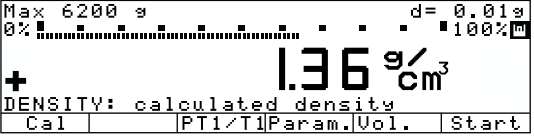
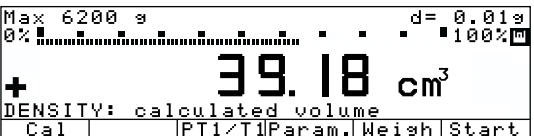
Step	Key (or instruction)	Display/Output
1. Delete previously stored values if necessary	<b>CF</b>	
2. Enter temperature: 22°C	<b>Param.</b> soft key <b>2 2</b> ↓ soft key << soft key	
3. Place the empty pycnometer on the balance		
4. Tare the balance	<b>TARE</b>	
5. Place the pycnometer, filled with water, on the balance		
6. Store the weight of the water	<b>Wf1</b> soft key	
7. Empty the pycnometer and place it on the balance		
8. Tare using the application tare memory	<b>PT1/T1</b> soft key	

Step	Key (or instruction)	Display/Output
9. Put the granulate sample in the pycnometer		
10. Store the weight	<b>Wa</b> soft key	
11. Clear the application tare memory	<b>CF</b> <b>PT1/T1</b> soft key	
12. With the granulate still in the pycnometer, fill the pycnometer with water		
13. Store the weight of the sample and the water; the density of the sample is displayed	<b>Wr</b> soft key	
14. Display volume of sample	<b>Vol.</b> soft key	
15. Display weight	<b>Densit</b> soft key	
16. Repeat procedure with next sample, if desired	<b>Start</b> soft key	

## Checkweighing

### Purpose

This program is used to check whether a sample corresponds to a pre-set target value or is within a specific tolerance range. In addition to the display in the measured value line, the results are shown on the bar graph and can also be routed through the interface port via control lines for further electronic processing.

You can use the "Checkweighing" application in combination with a program chosen from Application 1 (e.g., counting, weighing in percent) and one from Application 3 (totalizing, formulation, statistics).

### Available Features

- Optional configuration in the Setup menu for long-term storage of target value and tolerance limits
- Optional balance configuration in Setup for automatically initializing this application and loading the values stored in long term memory for the target value and the upper and lower tolerance limits when you turn on the balance
- You can perform checkweighing
  - without entering a target value, but only upper and lower tolerance limits;
  - as differential checkweighing;
  - with symmetric or asymmetric limits which can be entered as percentages
- Enter target value and limits by placing a load on the balance or using the numeric keys
- Control in entering target and tolerance values, so that the upper limit  $\geq$  the target  $\geq$  the lower limit  $\geq$  1 display increment
- Accuracy of a weight readout or keyboard input as target/tolerance values corresponds to the display accuracy
- Optional balance configuration in the Setup menu for automatic output to the interface port (print application parameters) of target value and tolerance limits when initialization is completed
- Control range for the balance's data output port lines is 30% to 170% of the target value
- Optional configuration in the Setup menu for activation of control lines dependent on weight value (weight value within control range, stability reached)
- Toggling the display between weight readout and control (checkweighing) display by pressing the corresponding soft key. If the weight value exceeds tolerances, the measured value line shows the weight while the control display shows "LL" for "too low" or "HH" for "too high."

- Press the **Show** soft key to display target value and tolerance limits in the text line after initializing the application.
- Weight value in bar graph displayed in relation to upper and lower limits and target value.
- "OK" value counter displayed in the text line (e.g., **n = 4**). This counter shows the number of measured values that lie within the tolerance range.
- Optional automatic printout of weight value when it is within the control range at stability  
After an automatic printout, the balance is blocked. Before you can generate the next printout, you must unblock the balance by unloading it (weight must be under 30% of the target) or by placing a load on the balance (bringing the weight up to at least 170% of the target).
- Press **[CF]** to delete the initialization parameters and end the Checkweighing program

### Factory Settings

Activation of port lines: **Within checkweighing range**

Type of checkweighing input:

**Target, minimum, maximum weight**

Weight display mode:

**Absolute value**

Automatic printout of OK values: **No**

### Soft Key Functions

- |               |  |
|---------------|--|
| <b>Param.</b> | Begin input of target and tolerance values                           |
| <b>Show</b>   | Display target and tolerance values in turn during checkweighing     |
| <b>LLHH</b>   | Toggle to control display ("LL" for too light and HH" for too heavy) |
| <b>Diff.</b>  | Display difference between current value and target                  |
| <b>Net</b>    | Display net weight   |

## Preparation

The checkweighing program often requires a target value for comparison with the current value. This target has a tolerance range, which is defined by absolute weight values. The tolerance range is defined as either an absolute value or a percentage with upper and lower limits. Percentage values can be symmetric or asymmetric to the target value. These values can be entered either by storing weights on the balance or by key input.

There are four control lines, called data output port lines, which are activated as follows: (see also the diagram at the right):

- lighter
- equal
- heavier
- set

The control range spans 30% to 170% of the target value. You can configure this parameter in the Setup menu (App: Application 2: Checkweighing: Activation of port lines:) to select whether the control lines are:

- activated within the control range
- always on
- activated at stability within the control range
- activated at stability

This makes it possible, for example, to connect a simple indicator for the weighing results (e.g., three different colors, one each for the weighing results: too light, O.K., too heavy).

## Response of Control Lines During Checkweighing

Configurations:

- always on
- activated at stability

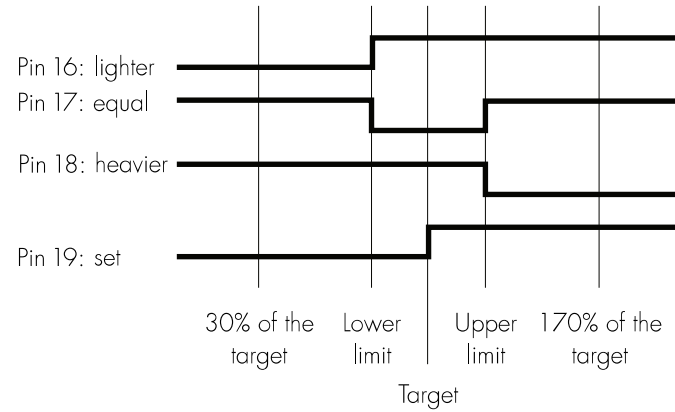

Configurations:

- activated within control range
- activated at stability within control range

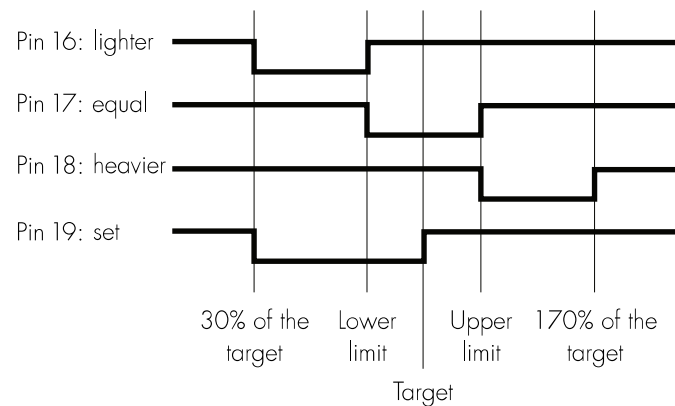



## Output port specifications

When not in use, the voltage level is high:  $>2.4\text{ V}/+2\text{ mA}$ .

When activated, the voltage level is low:  $<0.4\text{ V}/-2\text{ mA}$ .

⚠ The output ports are not protected against short circuits!

## Preparation

- Turn on the balance: Press 
- > Sartorius logo is displayed, self-test is performed
- Select the Checkweighing application in the Setup menu: Press 
- Select the Application menu: **APP** soft key
- Select **Application 2**: Press the **▼** soft key and then the **➤** soft key
- Select **Checkweighing**: **▲** or **▼** soft key repeatedly
- Confirm **Checkweighing**: **➤** soft key
- Select and confirm:
  - **Activation of port lines:**  
**Within checkweighing range** or  
**Always on** or  
**Stability and checkweighing range** or  
**At stability** or  
**Stability + checkweigh range ->on**
  - **Type of checkweighing input:**  
**Target, minimum, maximum weight** or  
**Minimum, maximum weight** or  
**Target, minimum in %, maximum in %**
  - **Weight display mode:**  
**Absolute value** or  
**Difference from the target**
  - **Automatic printout of OK values:**  
**Yes** or  
**No**
- see also the "Application Menu (Overview)" in the chapter entitled "Configuring the Balance"
- Save settings and exit the Setup menu: Press the **◀◀** soft key

## Additional Functions

In addition to the functions for:

- alphanumeric input, (not during initialization),
- taring (not during alphanumeric input)
- printing,

you can also access the following functions from this application:

### Calibration/Adjustment

- Press the **Cal** soft key
- > See "Calibration/Adjustment" for further instructions

### Toggle to Another Application

- Press 
- > See the section on the corresponding application program for further instructions

### Setup (setting parameters)

- Press 
- > See "Configuring the Balance" for further instructions

### Turning Off the Balance



- Press 
- > The balance shuts off
- > The display goes blank



## Practical Example

Checkweighing samples of 170 g, with an allowable tolerance of  $-5$  g and  $+10$  g. Printout of upper and lower tolerance limits. Weighed values are printed out automatically when stability is reached and weight value is within the control range.

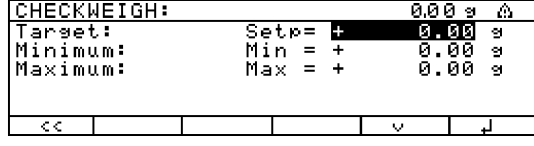
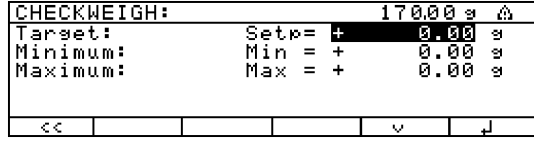
Settings (changes in the factory settings required for this example):

Setup: App: Application 2: Checkweighing: Automatic printout of OK values: Yes

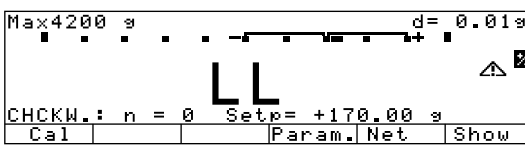
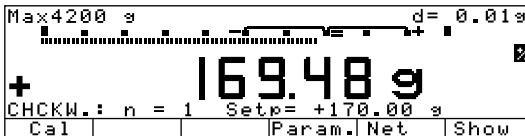
Step	Key (or instruction)	Display/Output
1. Turn on the balance and configure the settings as indicated above	<b>1/0</b>	
2. Delete previous setting if necessary	<b>CF</b>	
3. Prepare a container for the samples	Place empty container on the balance	 <p>Max 4200 g      d = 0.01 g            0% ■■■■■      ■■■■■ 100%  <b>+ 210.00 g</b>            CHECKWEIGH: Initialize            Cal      Param.      Start</p>
4. Tare the balance	<b>TARE</b>	 <p>Max 4200 g      d = 0.01 g            0% ■■■■■      ■■■■■ 100%  <b>0.00 g</b>            CHECKWEIGH: Initialize            Cal      Param.      Start</p>
5. Enter initialization values	<b>Param.</b> soft key	 <p>CHECKWEIGH:      0.00 g <math>\Delta</math>            Target:      Setp = + 0.00 g            Minimum:      Min = + 0.00 g            Maximum:      Max = + 0.00 g            &lt;&lt;      v      ↓</p>
6. Enter target value via the balance (here: 170 g)	Place ideal sample in container	 <p>CHECKWEIGH:      170.00 g <math>\Delta</math>            Target:      Setp = + 0.00 g            Minimum:      Min = + 0.00 g            Maximum:      Max = + 0.00 g            &lt;&lt;      v      ↓</p>
7. Store target value and unload balance	<b>↓</b> soft key Remove ideal sample from balance	 <p>CHECKWEIGH:      0.00 g <math>\Delta</math>            Target:      Setp = + 170.00 g            Minimum:      Min = + 0.00 g            Maximum:      Max = + 0.00 g            &lt;&lt;      ^      v      ↓</p>
8. Enter value for lower limit (170 g - 5 g) and store	<b>1 6 5</b> <b>↓</b> soft key	 <p>CHECKWEIGH:      0.00 g <math>\Delta</math>            Target:      Setp = + 170.00 g            Minimum:      Min = + 165.00 g            Maximum:      Max = + 0.00 g            &lt;&lt;      ^      ↓</p>

Step	Key (or instruction)	Display/Output									
9. Enter value for upper limit (170 g + 10 g) and store	1 8 0 ↓ soft key	 <table border="1" data-bbox="869 481 1404 593"> <tr> <td>Setp</td> <td>+</td> <td>170.00 g</td> </tr> <tr> <td>Min</td> <td>+</td> <td>165.00 g</td> </tr> <tr> <td>Max</td> <td>+</td> <td>180.00 g</td> </tr> </table>	Setp	+	170.00 g	Min	+	165.00 g	Max	+	180.00 g
Setp	+	170.00 g									
Min	+	165.00 g									
Max	+	180.00 g									
10. Weigh sample (in this case 169.48 g)	Place sample in container	 <table border="1" data-bbox="869 806 1404 862"> <tr> <td>N</td> <td>+</td> <td>169.48 g</td> </tr> </table>	N	+	169.48 g						
N	+	169.48 g									
If the weight value had been too low, the display would have shown the following:											
11. In this case, switch to net value display (here: 163.28 g)	<b>Net</b> soft key										
12. Weigh next sample (if any)	Place sample in container										

## Time-Controlled Functions

### Purpose

With this application program, you can configure the balance to perform certain functions (e.g., automatic printout of values, store value in totalization memory) at a given time or after a set interval.

You can use the "Time-Controlled Functions" application in combination with a program chosen from Application 1 (e.g., counting, weighing in percent) and one from Application 3 (e.g., totalizing, formulation).

### Available Features

- Time-controlled activation of balance functions:
  - one time only, at a given time  
(**Settings=** is displayed in the text line)
  - repeatedly, at given intervals  
(**Interval=** is displayed in the text line before the function is started, and **Repeat =** is displayed after the function is started)
- Functions that can be time-controlled include:
  - Acoustic signal
  - Lock in readout
  - Automatic printout of values
  - Store values for totalizing, formulation or statistics
- Print time in addition to weight value
- Store value independent of stability
- Tare the balance after printout of weight values
- Press the corresponding soft key to cancel time-controlled functions

### Factory Settings

Function after time interval:

**Automatic printout of values**

Automatic function restart: **On**

Storage mode:



**Without stability**

Print then tare: **On**

### Soft Key Functions

- Stop** Stop the application
- Quit** Confirm performed function (e.g., "Lock in readout" or "Beep")
- Interv** Store input interval for time-controlled functions
- Set.** Store input time for one-time performance of function

## Preparation

- Turn on the balance: Press 
  - > Sartorius logo is displayed
  - Select the "Time-controlled functions" application in the Setup menu: Press 
  - Select the Application menu: **APP** soft key
  - Select **Application 2**: Press the **▼** soft key and then the **▶** soft key
  - Select **Time-controlled functions**: **▲** or **▼** soft key
  - Confirm **Time-controlled functions**: **▶** soft key
  - Select and confirm:
    - **Function after time interval**:  
**Beep** or  
**Lock in readout** or  
**Automatic printout of values** or  
**Store value in applicat. 3 memory**
    - **Automatic function restart**:  
**On** or  
**Off**
    - **Storage mode**:  
**Without stability** or  
**After stability** or  
**After higher stability**
    - **Print then tare**:  
**Off** or  
**On**
- see also the "Application Menu (Overview)" in the chapter entitled "Configuring the Balance"
- Save settings and exit the Setup menu: Press the **◀◀** soft key

## Print Net Values without Printout of Time

Configuration settings:

Setup: App: Basic settings: Printout configuration: Auto. at init.: Off

## Additional Functions

In addition to the functions for:

- alphanumeric input,
- taring (not during alphanumeric input),
- printing,

you can also access the following functions from this application:

### Calibration/Adjustment

- Press the **Cal** soft key
- > See "Calibration/Adjustment" for further instructions

### Toggle to Another Application

- Press 
- > See the section on the corresponding application program for further instructions

### Setup (setting parameters)

- Press 
- > See "Configuring the Balance" for further instructions

### Turning Off the Balance

- Press 
- > The balance shuts off
- > The display goes blank

## Practical Example

Document the amount of evaporation of a sample with defined surface, temperature and air pressure at preset intervals of 1 minute, 30 seconds.

Settings (changes in the factory settings required for this example):

Setup: App: Application 2: Time-controlled functions

Setup: Menu: Balance functions: Taring: Without stability

Setup: Menu: Print in weighing mode: Manual/auto print mode: Manual without stability

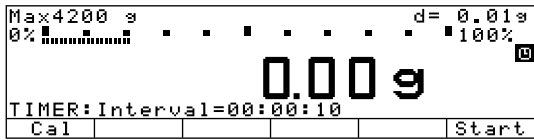
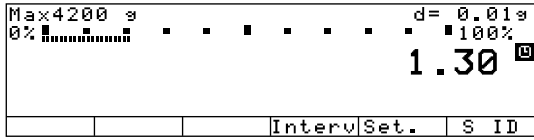
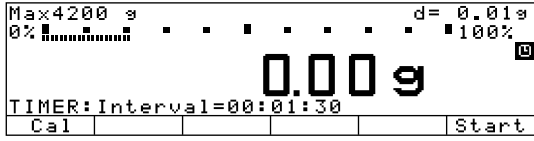
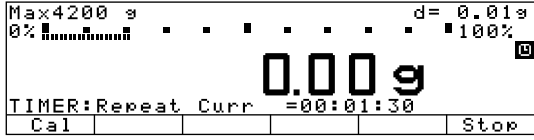
Step	Key (or instruction)	Display/Output
1. Turn on the balance and configure the settings as indicated above	<b>1/0</b>	
2. Delete stored values if necessary	<b>CF</b>	
3. Place container with sample on the balance and tare	<b>TARE</b>	
4. Enter time interval: 1 minute, 30 seconds	<b>1 . 3 0</b>	
5. Store time interval	<b>Interv</b> soft key	
6. Begin documentation (Time remaining until the next printout is displayed in the text line)	<b>Start</b> soft key	
Printout of evaporation amount every 1 1/2 minutes		<pre> Time:      15:19:50 N         -  0.37 g Time:      15:21:20 N         -  0.33 g Time:      15:22:50 N         -  0.30 g Time:      15:24:20 N         -  0.40 g           </pre>
7. Stop the documentation procedure	<b>Stop</b> soft key	

## Totalizing $\Sigma$

### Purpose

This application program acts as a cumulative memory function.

You can use the "Totalizing" application in combination with a program chosen from Application 1 (e.g., counting, weighing in percent) and one from Application 2 (check-weighing, time-controlled functions) as well as with the extra functions.

### Available Features

- Totalization of weight values and calculated values
- Optional configuration in the Setup menu for simultaneous storage of net and calculated values
- Optional configuration in the Setup menu for loading weight values and calculated values either from Application 1 (e.g., counting, weighing in percent) or from Application 2 (check-weighing, time-controlled functions)
- Totalization memory for up to 65535 values
- Simultaneous display in the text line of transaction counter and, e.g., the current total
- Optional configuration in the Setup menu for having the balance tare automatically after a value is stored in the totalization memory, if no preset tare has been entered
- Manual input of the number of individual weighing operations (target no. of operation **nDef**). Result printed and memory cleared after printout of **nDef**.
- Optional configuration in the Setup menu to add the current weight, with display accuracy, to the current total by pressing the **M+** soft key and generate a printout of the result

- Optional configuration in the Setup menu for stability-dependent storage of the measured value:  
**Stability range**

- Optional automatic storage of measured values

Storage of measured value is indicated by  $\rightarrow\leftarrow$ .

$\rightarrow\leftarrow$  indicates that you can place a load on the balance.

- Minimum load threshold for automatic storage
- Press the **M-** soft key to delete the last value added to the totalization memory. The transaction counter value is reduced by one and a printout is generated.
- Press the **MR** soft key for information about number of transactions and the current total. By configuring the Setup menu, you can define whether the information is displayed and printed, or only printed, and whether the information comprises an intermediate or final evaluation (see the example on page 69)
- In the Info window you can choose which value is displayed in the text line during weighing
- Printout of the end result independent of which program is configured for Application 1 or Application 2. Configure the Setup menu to define which values are included on the printout (Printout of individual components)
- Press the key identified by **MR** (soft key label) for a printout of an intermediate evaluation after each addition or a final evaluation
- If you end the totalization process by pressing **[CF]** without having first pressed the **MR** soft key for a printout, a final evaluation is printed when you press **[CF]**
- Optional configuration in the Setup menu to clear the totalization memory and reset the transaction counter by pressing **[CF]** or after an evaluation is printed out

- Totalization data and transaction counter data are stored in non-volatile memory

- Continue totalization after turning the balance off and back on

### Factory Settings

Automatic storage: **Off**

Minimum load for automatic storage:  
**10 digits**

Source of data for auto storage:  
**Application 1**

Evaluated values: **Net**

Evaluation mode, MR key function:  
**Intermediate evaluation, print**

M+/M- function, then tare: **Off**

Printout of individual components: **On**

Balance functions:

Stability range:  
**1-3-4 2 increments**

Tare after individual printout: **No**

### Soft Key Functions

**M+** Add weight values or application values to the total in the totalization memory. The component or transaction counter value increases by one each time you press this key.

**M-** Delete the last value added to memory. The transaction counter value decreases by 1. You cannot delete previous values by repeatedly pressing this key.

**MR** Print or display an intermediate or final evaluation

**nDef** Store the input number of components

### Printout for Totalizing

The transaction or component counter is printed in front of each measured value (weight). When an intermediate or final evaluation is printed out, all results up to this point are included.

**n** 5  
**Total + 151.67 g**

## Preparation

- Turn on the balance: Press **[I/O]**
- > Sartorius logo is displayed, self-test is performed
- Select the Totalizing application program in the Setup menu: Press **[SETUP]**
- Select the Application menu: **App** soft key
- Select **Application 3**: Press the **▼** soft key twice and then press **➤**
- Select **Totalizing**: **▲** or **▼** soft key
- Confirm **Totalizing**: **➤** soft key
- Select and confirm:
  - **Automatic storage**:  
**Off** or  
**On, first value at stability** or  
**On, last value at stability** or  
**On, value bet. 70-130% at stabil.**
  - **Minimum load for automatic storage**:  
**None** or  
**10 digits** or  
**20 digits** or  
**50 digits** or  
**100 digits** or  
**200 digits** or  
**500 digits** or  
**1000 digits**
  - **Source of data for auto storage**:  
**Application 1** or  
**Application 2**
  - **Evaluated values**:  
**Net** or  
**Calculated** or  
**Net + calculated**
  - **Evaluation mode, MR function**:  
**Intermediate evaluation, print** or  
**Final evaluation, print** or  
**Intermediate eval., display+print** or  
**Final evaluation, display+print**
  - **M+ / M- function, then tare**:  
**Off** or  
**On**
  - **Printout of individual components**:  
**No** or  
**Yes**

see also the "Application Menu (Overview)" in the chapter entitled "Configuring the Balance"
- Save settings and exit the Setup menu: Press the **◀◀** soft key

## Additional Functions

In addition to the functions for:

- alphanumeric input,
- taring (not during alphanumeric input),
- printing,

you can also access the following functions from this application:

### Calibration/Adjustment

- Press the **Cal** soft key
- > See "Calibration/Adjustment" for further instructions

### Toggle to Another Application

- Press **[↔]**
- > See the section on the corresponding application program for further instructions

### Setup (setting parameters)

- Press **[SETUP]**
- > See "Configuring the Balance" for further instructions

### Turning Off the Balance

- Press **[I/O]**
- > The balance shuts off
- > The display goes blank, then OFF/Standby is displayed with backlighting

## Practical Example







Totalize counted pieces

Settings (changes in the factory settings required for this example):

Setup: App: Application 1: Counting

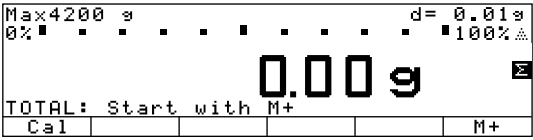
Setup: App: Application 3: Totalizing: Evaluated values: Net + calculated

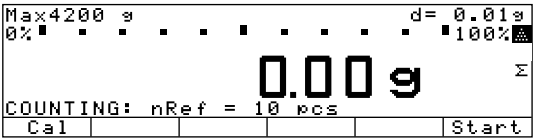
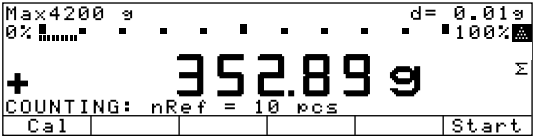
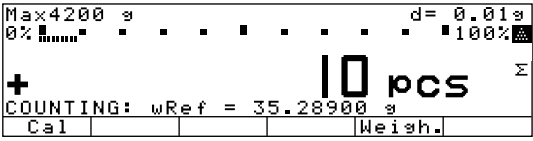
Setup: App: Application 3: Totalizing: Evaluation mode, MR function: Final evaluation, display + print

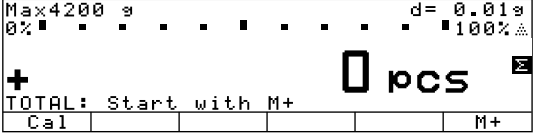
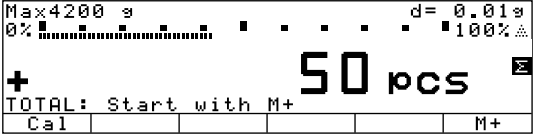
Step	Key (or instruction)	Display/Output				
1. Turn on the balance and configure the settings as indicated above						
2. Delete old totalization data, if necessary						
3. Tare the balance						
4. Toggle to Application 1: Counting						
5. Place the displayed number of parts on the balance (here: 10 pcs)	Place parts to be counted on the balance					
6. Initialize the Counting application	<b>Start</b> soft key	 <table border="1" data-bbox="871 1541 1406 1617"> <tr> <td>nRef</td> <td>10 pcs</td> </tr> <tr> <td>wRef</td> <td>35.28900 g</td> </tr> </table>	nRef	10 pcs	wRef	35.28900 g
nRef	10 pcs					
wRef	35.28900 g					
7. Remove the reference sample quantity and toggle to Totalizing	Unload the balance 					
8. Place a number of parts on the balance (here: 50 pcs)	Place parts on the balance					

Step	Key (or instruction)	Display/Output																																				
9. Store piece count	M+ soft key	<div style="border: 1px solid black; padding: 5px; margin-bottom: 10px;"> <p>Max4200 g <span style="float: right;">d= 0.01g</span>            0% <span style="float: right;">100%</span></p> <p style="text-align: center; font-size: 2em;"><b>+</b> 50 pcs</p> <p>TOTAL: n=1 <math>\Sigma</math> tot= + 100 pcs</p> <table border="1" style="width: 100%; border-collapse: collapse; font-size: 0.8em;"> <tr> <td style="width: 25%;">Cal</td> <td style="width: 25%;"></td> <td style="width: 25%;">MR</td> <td style="width: 25%;">M-</td> <td style="width: 25%;">M+</td> </tr> </table> </div> <div style="border: 1px solid black; padding: 5px; margin-bottom: 10px;"> <p style="text-align: center;">-----</p> <p>16.01.1997 <span style="float: right;">11:06</span></p> <p>n <span style="float: right;">1</span></p> <p>N + 1764.45 g</p> <p>QNT + 50 pcs</p> </div>	Cal		MR	M-	M+																															
Cal		MR	M-	M+																																		
10. Unload the balance	Remove parts from the balance																																					
11. Place another load of parts on the balance (e.g., 60 pcs)	Place parts on the balance	<div style="border: 1px solid black; padding: 5px; margin-bottom: 10px;"> <p>Max4200 g <span style="float: right;">d= 0.01g</span>            0% <span style="float: right;">100%</span></p> <p style="text-align: center; font-size: 2em;"><b>+</b> 60 pcs</p> <p>TOTAL: n=1 <math>\Sigma</math> tot= + 110 pcs</p> <table border="1" style="width: 100%; border-collapse: collapse; font-size: 0.8em;"> <tr> <td style="width: 25%;">Cal</td> <td style="width: 25%;"></td> <td style="width: 25%;">MR</td> <td style="width: 25%;">M-</td> <td style="width: 25%;">M+</td> </tr> </table> </div>	Cal		MR	M-	M+																															
Cal		MR	M-	M+																																		
12. Add piece count to stored total	M+ soft key	<div style="border: 1px solid black; padding: 5px; margin-bottom: 10px;"> <p>Max4200 g <span style="float: right;">d= 0.01g</span>            0% <span style="float: right;">100%</span></p> <p style="text-align: center; font-size: 2em;"><b>+</b> 60 pcs</p> <p>TOTAL: n=2 <math>\Sigma</math> tot= + 170 pcs</p> <table border="1" style="width: 100%; border-collapse: collapse; font-size: 0.8em;"> <tr> <td style="width: 25%;">Cal</td> <td style="width: 25%;"></td> <td style="width: 25%;">MR</td> <td style="width: 25%;">M-</td> <td style="width: 25%;">M+</td> </tr> </table> </div> <div style="border: 1px solid black; padding: 5px; margin-bottom: 10px;"> <p>n <span style="float: right;">2</span></p> <p>N + 2117.34 g</p> <p>Qnt + 60 pcs</p> </div>	Cal		MR	M-	M+																															
Cal		MR	M-	M+																																		
13. Repeat steps 10 and 11 as required																																						
14. Display final evaluation ("Info" window) (here: 5 weighing operations; total weight: 8751.67 g; total quantity: 248) The  indicates which value is displayed in the text line; you can change this selection	MR soft key	<table border="1" style="width: 100%; border-collapse: collapse; font-size: 0.8em;"> <tr> <td colspan="2" style="text-align: left;"><b>TOTAL:</b></td> <td></td> <td></td> <td></td> <td></td> </tr> <tr> <td>oNet: n</td> <td>=</td> <td style="background-color: black; color: white;">5</td> <td></td> <td></td> <td></td> </tr> <tr> <td>Net: <math>\Sigma</math></td> <td>=</td> <td>+ 8751.67 g</td> <td></td> <td></td> <td></td> </tr> <tr> <td>Calculated: n</td> <td>=</td> <td>5</td> <td></td> <td></td> <td></td> </tr> <tr> <td>Calculated: <math>\Sigma</math></td> <td>=</td> <td>+ 248 pcs</td> <td></td> <td></td> <td></td> </tr> <tr> <td>&lt;&lt;</td> <td></td> <td></td> <td></td> <td>v</td> <td>↓</td> </tr> </table>	<b>TOTAL:</b>						oNet: n	=	5				Net: $\Sigma$	=	+ 8751.67 g				Calculated: n	=	5				Calculated: $\Sigma$	=	+ 248 pcs				<<				v	↓
<b>TOTAL:</b>																																						
oNet: n	=	5																																				
Net: $\Sigma$	=	+ 8751.67 g																																				
Calculated: n	=	5																																				
Calculated: $\Sigma$	=	+ 248 pcs																																				
<<				v	↓																																	
15. Print final evaluation		<div style="border: 1px solid black; padding: 5px; margin-bottom: 10px;"> <p style="text-align: center;">-----</p> <p>n <span style="float: right;">5</span></p> <p>Total + 8751.67 g</p> <p>Total + 248 pcs</p> <p>16.01.1997 <span style="float: right;">11:16</span></p> <p style="text-align: center;">-----</p> </div>																																				

## Formulation

### Purpose

With this application program you can add weight values and calculated values to a totalization memory as components of a formula.

You can use the "Formulation" application in combination with a program chosen from Application 1 (except Recalculation) and one from Application 2 (checkweighing, time-controlled functions) as well as with the extra functions.

### Available Features

- Totalization of weight values and calculated values
- Weigh in different components to a total amount defined by pressing the **Nom** soft key and entering the value through the numeric keys
- Simultaneous storage of net and calculated values
- Optional configuration in the Setup menu for loading weight values and calculated values either from Application 1 (e.g., counting, weighing in percent) or from Application 2 (checkweighing, time-controlled functions)
- Totalization memory for up to 65535 values
- Transaction counter and current total displayed in the text line
- Balance tared after a value is stored
- Manual input of the number of individual weighing operations (target no. of operation **nDef**). Result printed and memory cleared after printout of **nDef**.
- Optional configuration in the Setup menu to add the current weight, with display accuracy, to the current total by pressing the **M+** soft key and generating a printout of the result
- Optional configuration in the Setup menu for stability-dependent storage of the measured value:  
**Stability range**
- Optional automatic storage of measured values  
Storage of measured value is indicated by **↔**.  
**↕↕** indicates that you can place a load on the balance.
- Minimum load threshold for automatic storage
- Press the **M-** soft key to delete the last value added to the totalization memory.  
The transaction counter value is reduced by one and a printout is generated.
- Printout of an evaluation of results, depending on the Application 1 or Application 2 parameters.  
Configure the Setup menu to define the information included on this printout.
- Press the key identified by **MR** (soft key) for a printout of an intermediate evaluation after each addition or a final evaluation
- A final evaluation is printed when the formulation routine is ended by pressing **[CF]**, if no final evaluation was generated by pressing **MR**
- Optional configuration in the Setup menu to clear the totalization memory and reset the transaction counter by pressing **[CF]** or after an evaluation is printed out
- Totalization data and transaction counter data are stored in non-volatile memory
- Continue formulation after turning the balance off and back on

## Factory Settings

Automatic storage: **Off**

Minimum load for automatic storage:  
**10 digits**

Source of data for auto storage:  
**Application 1**

Evaluated values: **Net**

Evaluation mode, MR key function:  
**Intermediate evaluation, print**

Printout of individual components: **On**

Balance functions:

Stability range:  
**1-3-4 2 increments**

Print in weighing mode.

Print on request, then tare: **Off**

## Soft Key Functions

**M+** Add weight values or application values to the total in the totalization memory. The component or transaction counter value increases by one each time you press this key.

**M-** Delete the last value added to memory. The transaction counter value decreases by 1. You cannot delete previous values by repeatedly pressing this key.

**MR** Print or display an intermediate or final evaluation

**nDef** Store the input number of components

**Nom** Press to enter target component weight using the numeric keys

## Printout of Formulation Report



When an intermediate or final evaluation is printed out, all results up to this point are included.

**Comp2 + 42.38 g**  
**Tot.cp+184.89 g**

Comp2: Weight of the 2nd component

Tot.cp: Total of all components

## Preparation

- Turn on the balance: Press 
  - > Sartorius logo is displayed, self-test is performed
  - Select the Formulation application program in the Setup menu: Press 
  - Select the Application menu: **APP** soft key
  - Select **Application 3**: Press the **▼** soft key twice and then press **➤**
  - Select **Formulation**: **▲** or **▼** soft key
  - Confirm **Formulation**: **➤** soft key
  - Select and confirm:
    - **Automatic storage**:  
Off or  
On, first value at stability.
    - **Minimum load for automatic storage**:  
None or  
10 digits or  
20 digits or  
50 digits or  
100 digits or  
200 digits or  
500 digits or  
1000 digits
    - **Source of data for auto storage**:  
Application 1 or  
Application 2
    - **Evaluated values**:  
Net or  
Calculated or  
Net + calculated
    - **Evaluation mode, MR function**:  
Intermediate eval., print or  
Final evaluation, print
    - **Printout of individual components**:  
No or  
Yes
- see also the "Application Menu (Overview)" in the chapter entitled "Configuring the Balance"
- Save settings and exit the Setup menu: Press the **◀◀** soft key

## Additional Functions

In addition to the functions for:

- alphanumeric input,
- taring (not during alphanumeric input),
- printing,

you can also access the following functions from this application:

### Calibration/Adjustment

- Press the **Cal** soft key
- > See "Calibration/Adjustment" for further instructions

### Toggling to Another Application

- Press 
- > See the section on the corresponding application program for further instructions

### Setup (setting parameters)

- Press 
- > See "Configuring the Balance" for further instructions

### Turning Off the Balance

- Press 
- > The balance shuts off
- > The display goes blank, then OFF/Standby is displayed with backlighting

## Practical Example





### Weighing in Components

Settings (changes in the factory settings required for this example):

Setup: App: Application 3: Formulation: Automatic storage: On, first value at stability

Setup: App: Application 3: Formulation: Minimum load for automatic storage: 100 digits

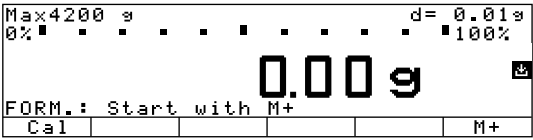
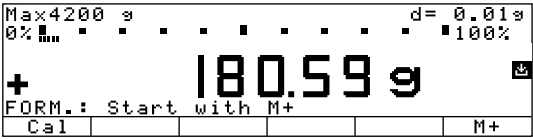
Setup: App: Application 3: Formulation: Evaluation mode, MR function: Final evaluation, print

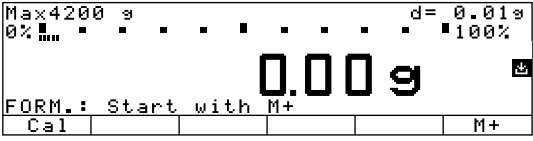
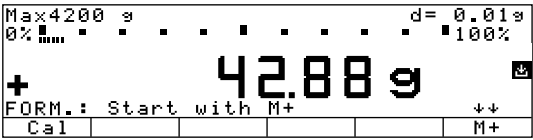
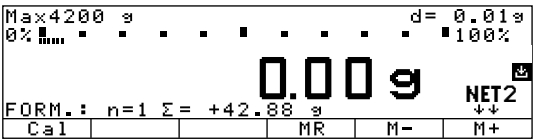
Step	Key (or instruction)	Display/Output
1. Turn on the balance and configure the settings as indicated above		
2. Delete old formulation data, if necessary		
3. Tare the balance		
4. Place the empty container on the balance (here: 180.59 g)	Place load on the balance	
5. Tare the balance		
6. Weigh in the first component (here: 42.88 g)	Place components in container	
7. Store components in the formulation memory Balance is tared automatically	<b>M+</b> soft key	
Components are printed out automatically		<pre> ----- 16.01.1997      14:04 Comp1 +      42.88 g           </pre>

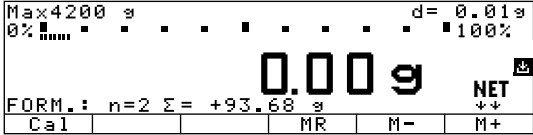
Step	Key (or instruction)	Display/Output
<p>8. Weigh in the next component (here: 50.80 g)</p> <p>Components are stored in the totalization memory at stability and printed out</p> <p>Balance is tared automatically</p>	Place components in container	<p style="text-align: center;"><b>Comp2 + 50.80 g</b></p> 
9. Repeat step 7 as required		
10. Print final evaluation (here: with total weight of all components: 212.43 g)	<b>MR</b> soft key	<pre> ----- n                2 Tot.cp+         212.43 g 16.01.1997      14:10 -----                     </pre>
11. Delete old formulation data, if necessary	<b>CF</b>	

## Statistics

### Purpose

With this application program you can have weight values and calculated values totalized and statistically evaluated.

The values determined for the evaluation are:

- average
- standard deviation
- variation coefficient
- sum of all values
- lowest value (minimum)
- highest value (maximum)
- difference between the minimum and the maximum

You can use the "Statistics" application in combination with a program chosen from Application 1 (e.g., counting, weighing in percent) and one from Application 2 (checkweighing, time-controlled functions) as well as with the extra functions.

### Available Features

- Storage of weight values and calculated values
- Simultaneous storage of net and calculated values
- Optional configuration in the Setup menu for loading weight values and calculated values either from Application 1 (e.g., counting, weighing in percent) or from Application 2 (checkweighing, time-controlled functions)
- Totalization memory for up to 65535 values
- Simultaneous display in the text line of transaction counter and, e.g., the current total
- Optional configuration in the Setup menu for having the balance tare automatically after a value is stored in the totalization memory
- Manual input of the number of individual weighing operations (target no. of operation **nDef**). Result printed and memory cleared after printout of **nDef**.

- Optional configuration in the Setup menu to add the current weight, with display accuracy, to the current total by pressing the **M+** soft key and generate a printout of the result
- Optional configuration in the Setup menu for stability-dependent storage of the measured value:  
Balance functions: **Stability range**
- Optional automatic storage of measured values  
Storage of measured value is indicated by **→←**.  
**++** indicates that you can place a load on the balance.
- Minimum load threshold for automatic storage
- Press the **M-** soft key to delete the last value added to the totalization memory. The transaction counter value is reduced by one and a printout is generated.
- Press the **MR** soft key for information about number of transactions and the current total. By configuring the Setup menu, you can define whether the information is displayed and printed, or only printed, and whether the information comprises an intermediate or final evaluation (see the example on page 96)
- In the Info window you can use the **↕**, **↓** soft keys to choose which value is displayed in the text line during weighing
- Printout of the end result depending on the Application 1 or Application 2 parameters. Configure the Setup menu to define which values are included on the printout (Printout of individual components)
- Press **MR** for a printout of an intermediate evaluation after each addition or a final evaluation
- A final evaluation is printed when the statistics routine is ended by pressing **[CF]**, if no final evaluation was generated by pressing **MR**

- Optional configuration in the Setup menu to clear the totalization memory and reset the transaction counter by pressing **[CF]** or after an evaluation is printed out
- Totalization data and transaction counter data are stored in non-volatile memory
- Continue totalization after turning the balance off and back on

### Factory Settings

Automatic storage: **Off**

Minimum load for automatic storage:  
**10 digits**

Source of data for auto storage:  
**Application 1**

Evaluated values: **Net**

Evaluation mode, MR key function:  
**Intermediate evaluation, print**

M+/M- function, then tare: **Off**

Printout of individual components:  
**Off**

Balance function:  
Stability range:  
**1-3-4 2 increments**

Print in weighing mode: **Off**  
Print on request, then tare

### Soft Key Functions



**M+** Add weight values or application values to the total in the totalization memory. The component or transaction counter value increases by one each time you press this key.

**M-** Delete the last value added to memory. The transaction counter value decreases by 1. You cannot delete previous values by repeatedly pressing this key.

**MR** Print or display an intermediate or final evaluation

**nDef** Store the input number of components

## Preparation

- Turn on the balance: Press 
- > Sartorius logo is displayed
- Select the Statistics application program in the Setup menu: Press 
- Select the Application menu: **App** soft key
- Select **Application 3**: Press the **▼** soft key twice and then press **►**
- Select **Statistics**: **▲** or **▼** soft key
- Confirm **Statistics**: **►** soft key
- Select and confirm:
  - **Automatic storage**:  
 Off or  
 On, first value at stability or  
 On, last value at stability or  
 On, value bet. 70-130% at stabil.
  - **Minimum load for automatic storage**:  
 None or  
 10 digits or  
 20 digits or  
 50 digits or  
 100 digits or  
 200 digits or  
 500 digits or  
 1000 digits
  - **Source of data for auto storage**:  
 Application 1 or  
 Application 2
  - **Evaluated values**:  
 Net or  
 Calculated or  
 Net + calculated
  - **Evaluation mode, MR function**:  
 Intermediate evaluation, print or  
 Final evaluation, print or  
 Intermediate eval., display+print or  
 Final evaluation, display+print
  - **M+ / M- function, then tare**:  
 Off or  
 On
  - **Printout of individual components**:  
 No or  
 Yes

see also the "Application Menu (Overview)" in the chapter entitled "Configuring the Balance"
- Save settings and exit the Setup menu: Press the **◀◀** soft key

## Additional Functions

In addition to the functions for:

- alphanumeric input,
- taring (not during alphanumeric input),
- printing,

you can also access the following functions from this application:

### Calibration/Adjustment

- Press the **Cal** soft key
- > See "Calibration/Adjustment" for further instructions

### Toggle to Another Application

- Press 
- > See the section on the corresponding application program for further instructions

### Setup (setting parameters)

- Press 
- > See "Configuring the Balance" for further instructions

### Turning Off the Balance

- Press 
- > The balance shuts off
- > The display goes blank, then OFF/Standby is displayed with backlighting

## Practical Example







Totalize counted pieces and print out statistics

Settings (changes in the factory settings required for this example):

Setup: App: Application 1: Counting: Average piece weight updating: Manual

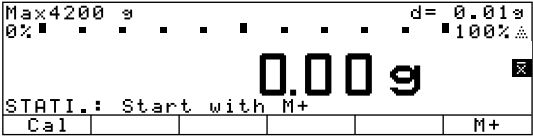
Setup: App: Application 3: Statistics: Evaluated values: Calculated

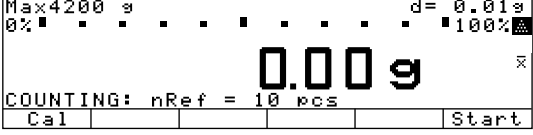
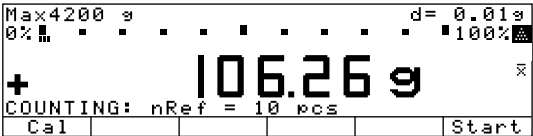
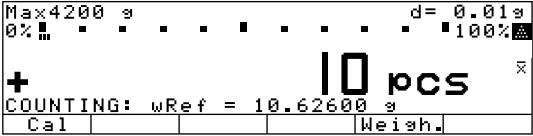
Setup: App: Application 3: Statistics: Evaluation mode, MR function: Final evaluation, display + print

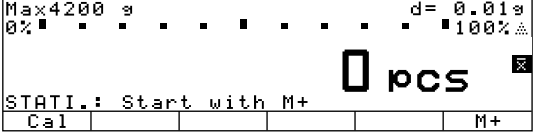
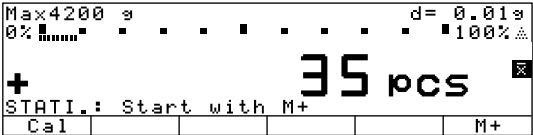
Step	Key (or instruction)	Display/Output				
1. Turn on the balance and configure the settings as indicated above						
2. Delete old statistics data, if necessary						
3. Tare the balance						
4. Toggle to Application 1: Counting						
5. Place the displayed number of parts on the balance (here: 10 pcs)	Place parts to be counted on the balance					
6. Initialize the Counting application	<b>Start</b> soft key	 <table border="1" data-bbox="871 1547 1406 1626"> <tr> <td>nRef</td> <td>10 pcs</td> </tr> <tr> <td>wRef</td> <td>10.62600 g</td> </tr> </table>	nRef	10 pcs	wRef	10.62600 g
nRef	10 pcs					
wRef	10.62600 g					
7. Remove the reference sample quantity and toggle to Statistics	Unload the balance 					
8. Place a number of parts on the balance (here: 35 pcs)	Place parts on the balance					



## Extra Functions (in the Application Menu)

### Second Tare Memory (Preset Tare)

#### Purpose

With this function you can store the weight currently on the balance as a tare weight, or use the numeric keys to enter a number for a preset tare weight.

You can use "Extra Functions" in combination with a program from Application 1 (e.g., counting, weighing in percent), one from Application 2 (checkweighing, time-controlled functions) and one from Application 3 (totalizing, formulation, statistics) as well as with the extra functions.

#### Available Features

- Store a weight on the balance in the second tare memory (without numeric input)
- Store a numeric value in the second tare memory (input using the numeric keys)
- Label a net value as **NET1** when there is a value stored in the second tare
- You can assign this function to the fourth or fifth soft key (from the right), i.e. F4 or F5  
The soft key designation for this function is: **PT1/T1**
- Optional configuration in the Setup menu for storing the current weight readout as the container tare weight. Any load subsequently placed on the scale that is more than 70% of the tare weight is automatically recognized as a container and the scale is tared automatically.
- Automatic printout when a value is stored or input (see "Configuring the Balance")
- Press **[CF]** to delete the (preset) tare value

#### Factory Settings

Container tare weight: **No**

Automatic printout: **Off**

#### Soft Key Functions

**PT1/T1** Store weight as tare value

**PT1** Save tare weight entered using the numeric keys

#### Printout of the Data in the 2nd Tare Memory

The printout shows either

- Net value **N1**
- Tare weight **T1**, or
- Manually entered tare value **PT1**

```
N1      163.48 g
T1      138.73 g
PT1     150.00 g
```

N1: Net weight /value) when a weight is stored in the tare memory

T1: Tare weight

PT1: Preset tare value entered using the numeric keys

#### Preparation

- Turn on the balance: Press **[ON]**
- > Sartorius logo is displayed, self-test is performed
- Select Extra function (F4) or Extra function (F5) in the Setup menu: Press **[SETUP]**
- Select the Application menu: **APP** soft key
- Select **Extra func. (F4)** or **Extra func. (F5)**
- Select **2nd tare memory**
- Confirm **2nd tare memory**
- Select and confirm:
  - **Container tare weight:**  
**No** or  
**Yes**
  - **Automatic printout:**  
**Net value** or  
**Tare/preset tare** or  
**Off**

see also the "Application Menu (Overview)" in the chapter entitled "Configuring the Balance"

- Save settings and exit the Setup menu: Press the **[<<]** soft key

#### Second Tare Memory in Legal Metrology





- Press the **(i)PT1** softkey to enter information about the tare value using the number keys.
- The PT1 tare value is printed out with the net value.

## Practical Example

Determine the Contents of Bottles: Bottle weight = 400 g.

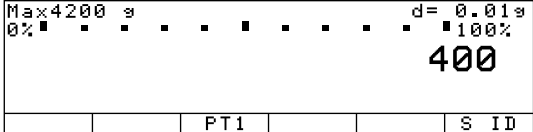
Settings (changes in the factory settings required for this example):

Setup: App: Extra function(F4): 2nd tare memory: Automatic printout: Tare/preset tare

Step	Key (or instruction)	Display/Output
1. If necessary: turn on the balance and enter the settings given above		
2. Enter bottle weight (here: 400 g)	<input type="text" value="4"/> <input type="text" value="0"/> <input type="text" value="0"/>	
3. Store tare value	PT1 soft key	 
4. Determine content weight of bottles (here: contents = 650 g)	Place filled bottles on the balance	

## Individual Identification Codes (ID)

### Purpose

With this function you can assign identifiers to values for documentation and printouts.

You can use this extra function in combination with a program from Application 1 (e.g., counting, weighing in percent), one from Application 2 (checkweighing, time-controlled functions) and one from Application 3 (totalizing, formulation, statistics) as well as with the other extra functions.

### Available Features

- Store up to 4 IDs; these can be stored, changed or deleted individually.
- Each ID consists of a name and a value; both can be defined by the user.
- ID designations are configured in the Setup: Input menu.
- Each ID designation can have up to 20 characters; when you enter the value later, however, no more than 15 characters of the designation are displayed.
- The ID values are entered while the application program is active; press the **ID** soft key to toggle to the ID input mode.
- Each ID value can have up to 20 characters.
- Access 1 of the 4 IDs directly using the numeric keys. The other three can only be accessed by pressing the **ID** soft key to toggle to the identifier input mode.
- You can assign this function to the fourth or fifth soft key (from the right), i.e. F4 or F5.
- You can configure when the ID is included on the printout (see "Preparation," this page).
- You can configure the position of IDs on the individual or total printout.
- The designation is printed flush left; the value flush right. If the name and value together are too long for one line, the data is printed on two lines.
- Optional configuration in the Setup menu to delete a single character when entering an identifier by pressing **[CF]**. Basic settings: Keypad: CF function for input: Delete last character
- Press the **Delete** soft key to delete an ID

### Factory Settings for ID Designations

ID1: **ID1**  
ID2: **ID2**  
ID3: **ID3**  
ID4: **ID4**

### Factory Settings for ID Values

No values set

### Factory Settings for Other Parameters

Printout: **Each time the print key is pressed**

### Soft Key Functions

**ID** Toggle to "Identification codes" menu

**Delete** Delete input of selected ID

## Preparation

- Turn on the balance: Press 
- > Sartorius logo is displayed
- Select Extra function (F4) or Extra function (F5) in the Setup menu:  
Press 
- Select the Application menu: **APP** soft key
- Select **Extra function(F4)** or **Extra function(F5)**
- Select **Identification codes**
- Confirm **Identification codes**
- Select and confirm:
  - **Printout:**  
 Automatic, if configured or  
 Once aft. pressing Print, if config. or  
 Each time the print key is pressed or  
 Once for M+ func. (app.3 memory)

see also the "Application Menu (Overview)" in the chapter entitled  
"Configuring the Balance"
- Save settings for the printout: Press the **<<** soft key
- Enter identifier name: Press the **Input** soft key
- Select **ID1**
- Enter designation for **ID1** and confirm: Use the numeric keys for numbers and/or the soft keys to enter letters
- Enter designations for **ID2**, **ID3** and **ID4**, if desired
- Save settings and exit the Setup menu: Press the **<<** soft key

## Practical Example

See the next page

## Practical Example

Include Company Address and Sample Lot Number on the Printout. Each Identifier Line Begins with the Name. Include This ID on Every Printout of the Net Value.

Settings (changes in the factory settings required for this example):

Setup: App: Extra function (F4): Identification codes

Setup: Input: ID1: COMPANY

Setup: Input: ID2: LOCATION

Setup: Input: ID3: STREET

Setup: Input: ID4: LOT

Step	Key (or instruction)	Display/Output
1. If necessary: turn on the balance		
2. Select "Extra Function (F4)" in the Setup menu	SETUP App soft key v soft key twice > soft key	<pre> SETUP      APPLICATION EXT.FCT.F4 oOff 2nd tare memory Identification codes Man. store in app.3 memory (M+) Product data memory &lt;&lt; Menu &lt; v &gt;           </pre>
3. Select "Identification codes"	v or ^ soft key; repeatedly, if necessary	<pre> SETUP      APPLICATION EXT.FCT.F4 oOff 2nd tare memory Identification codes Man. store in app.3 memory (M+) Product data memory &lt;&lt; Menu &lt; ^ v &gt;           </pre>
4. Confirm	> soft key	<pre> APPLICATION EXT.FCT.F4 ID Printout &lt;&lt; Menu &lt; &gt;           </pre>
5. Store choice of ID and access the main menu	< soft key << soft key	<pre> SETUP      SELECTION Config =&gt; Printout configuration App =&gt; Application menu Info =&gt; Balance/scale parameters Menu =&gt; Balance/scale menu Ineut =&gt; User data &lt;&lt; Config App Info Menu Ineut           </pre>
6. Select "ID1"	Ineut soft key v soft key 8 times	<pre> SETUP      INPUT Time: 13.39.33 Date: 26.07.97 Contrast(0-4): 2 Password: ID1: ID1 &lt;&lt; ^ v &gt;           </pre>
7. Enter name for ID1 (here: COMPANY)	ABC ... see also page 34 ABC	<pre> SETUP      INPUT Time: 13.39.33 Date: 26.07.97 Contrast(0-4): 2 Password: ID1: COMPANY ID2: ID2 &lt;&lt; ^ v &gt;           </pre>
8. Confirm	↓ soft key	<pre> SETUP      INPUT Date: 26.07.97 Contrast(0-4): 2 Password: ID1: COMPANY ID2: ID2 &lt;&lt; ^ v &gt;           </pre>

Step	Key (or instruction)	Display/Output
9. Repeat steps 7 and 8 for: ID2: LOCATION ID3: STREET ID4: LOT		<pre> SETUP      INPUT ID1:                               COMPANY ID2:                               LOCATION ID3:                               STREET ID4:                               LOT Adj. time1: &lt;&lt;      ^      v      ↓           </pre>
10. Save settings, exit the Setup menu and select input mode for ID values	<< soft key twice ID soft key	<pre> ID: COMPANY LOCATION STREET LOT &lt;&lt; Delete      v      ↓           </pre>
11. Enter name of company (here: Sartorius)	[ABC] ... See also page 39	<pre> ID: COMPANY                SARTORIUS LOCATION STREET LOT &lt;&lt; Delete      v      ↓           </pre>
12. Confirm	↓ soft key	<pre> ID: COMPANY                SARTORIUS LOCATION STREET LOT &lt;&lt; Delete      ^      v      ↓           </pre>
13. Repeat steps 11 and 12 for LOCATION: GOETTINGEN STREET: WEENDER LANDSTRASSE LOT: 15		<pre> ID: COMPANY                SARTORIUS LOCATION                GOETTINGEN STREET                WEENDER LANDSTRASSE LOT                    15 &lt;&lt; Delete      ^      v      ↓           </pre>
14. Place the first sample on the balance (here: 210.53 g)	Place load on balance	<pre> Max 6200 g          d= 0.01g 0% 100%            100% +      210.53g Cal      ID           </pre>
15. Print weight value (if desired, perform further weighing operations and print results)	[⊙]	<pre> COMPANY      SARTORIUS LOCATION      GOETTINGEN STREET WEENDER LANDSTRASSE LOT          15 N      +      210.53 g           </pre>
16. When weighing is completed, delete each ID individually	ID soft key Delete soft key 4 times	<pre> ID: COMPANY                SARTORIUS LOCATION                GOETTINGEN STREET                WEENDER LANDSTRASSE LOT                    15 &lt;&lt; Delete      v      ↓           </pre>

## Saving Valves Manually (M+)

### Purpose

With this function you can load weight values and calculation results directly from Application 1 (e.g., counting, weighing in percent) or Application 2 (checkweighing, time-controlled functions) into Application 3 (totalizing, formulation, statistics).



### Available Features

- You can assign this function to the fourth or fifth soft key (from the right), i.e. F4 or F5  
The soft key designation for this function is: **M+**
- An Application 3 program (totalizing, formulation or statistics) must be running so you can display and print the result

### Factory Settings

There are no optional parameters

### Preparation

- Turn on the balance: Press 
- > The Sartorius logo is displayed
- Select Extra function (F4) or Extra function (F5) in the Setup menu: Press 
- Select the Application menu: **APP** soft key
- Select **Extra func. (F4)** or **Extra func. (F5)**
- Select **Man. store in app.3 memory (M+)**
- Confirm **Man. store in app.3 memory (M+)**  
see also the “Application Menu (Overview)” in the chapter entitled “Configuring the Balance”
- Save settings and exit the Setup menu: Press the **◀◀** soft key

## Product Data Memory

### Purpose

With this function you can enter, store and load data records for initialization of applications, including user-defined data.

You can use this extra function in combination with a program from Application 1 (e.g., counting, weighing in percent), one from Application 2 (checkweighing, time-controlled functions) and the other extra functions for F4 and F5 (identification codes, 2nd tare memory).

### Available Features

- Store up to 300 data records.
- Data records can be created, stored or deleted individually.
- Press the **ProDat** soft key to display product data.
- Define a name for each data record of up to 15 alphanumeric characters.
- Optional configuration in the Setup menu to delete a single character when entering a data record name by pressing **[CF]**. Basic settings: Keypad: CF function for input: Delete last character.
- Data records are displayed in alphabetical order.
- Initialization data set for an application (such as wRef, nRef) is saved when you select the Store option. With several applications and extra functions active, you can select the desired parameters before saving the data to define initialization data.
- Use the alphanumeric keypad to search for and display individual data records.
- You can assign this function to the fourth or fifth soft key (from the right), i.e. F4 or F5.
- Error messages are displayed in the text line in plain English.
- Press the **Delete** soft key to delete a data record.

### Data Battery-Backed Data Memory

When the balance is disconnected from AC power, these balance-generated data will remain stored for approx. three months. In the standby mode, data are retained by the power supply.



### Factory Settings

No user-definable parameters.

### Soft Key Functions

- ProDat** Toggle to product data display
- Delete** Delete selected data record
- Load** Overwrite the initialization data with the selected data record
- Change** Change the data in the stored data record
- Store** Store the initialization data of the selected application under the chosen data record name. If data already exist for this data record, a prompt asks whether this data should be overwritten.
- No** Answer no to cancel a "delete" or "overwrite" operation
- Yes** Answer yes to perform the "delete" or "overwrite" operation
- New** Create a new data record (after entering a data record name) and selecting an application, if desired).

## Preparation

- Turn on the balance: Press 
- > Sartorius logo is displayed
- Select Extra function (F4) or Extra function (F5) in the Setup menu:  
Press 
- Select the Application menu: **App** soft key
- Select **Extra function(F4)** or **Extra function(F5)**
- Select **Product data memory**
- Confirm **Product data memory**  
see also the "Application Menu (Overview)" in the chapter entitled  
"Configuring the Balance"
- Save settings and exit the Setup menu: Press the  soft key

## Practical Example

Create a New Base Data Record for Initializing the Checkweighing Program, Including: Target Value, Minimum, Maximum Settings (changes in the factory settings required for this example):

Setup: App: Extra function (F4): Product data memory

Setup: App: Application 2: Checkweighing

Step	Key (or instruction)	Display/Output																					
1. If necessary: turn on the balance and enter the settings given above																							
2. In the Checkweighing application, toggle to the input mode for target, minimum and maximum values	<b>Param.</b> soft key	<table border="1"> <tr><td colspan="2"><b>CHECKWEIGH:</b></td><td>0.00 g</td></tr> <tr><td>Target:</td><td>Setp= +</td><td>0.00 g</td></tr> <tr><td>Minimum:</td><td>Min = +</td><td>0.00 g</td></tr> <tr><td>Maximum:</td><td>Max = +</td><td>0.00 g</td></tr> <tr><td>&lt;&lt;</td><td></td><td>v</td></tr> </table>	<b>CHECKWEIGH:</b>		0.00 g	Target:	Setp= +	0.00 g	Minimum:	Min = +	0.00 g	Maximum:	Max = +	0.00 g	<<		v						
<b>CHECKWEIGH:</b>		0.00 g																					
Target:	Setp= +	0.00 g																					
Minimum:	Min = +	0.00 g																					
Maximum:	Max = +	0.00 g																					
<<		v																					
3. Enter target: 170 g; minimum: 165 g; maximum: 180 g	see the Practical Example for Checkweighing, steps 5 through 9	<table border="1"> <tr><td colspan="2"><b>CHECKWEIGH:</b></td><td>170.00 g</td></tr> <tr><td>Target:</td><td>Setp= +</td><td>0.00 g</td></tr> <tr><td>Minimum:</td><td>Min = +</td><td>0.00 g</td></tr> <tr><td>Maximum:</td><td>Max = +</td><td>0.00 g</td></tr> <tr><td>&lt;&lt;</td><td></td><td>^</td></tr> </table>	<b>CHECKWEIGH:</b>		170.00 g	Target:	Setp= +	0.00 g	Minimum:	Min = +	0.00 g	Maximum:	Max = +	0.00 g	<<		^						
<b>CHECKWEIGH:</b>		170.00 g																					
Target:	Setp= +	0.00 g																					
Minimum:	Min = +	0.00 g																					
Maximum:	Max = +	0.00 g																					
<<		^																					
4. Toggle to display of product data (existing data records are displayed; in this example, 3 data records have been stored)	<b>ProDat</b> soft key	<table border="1"> <tr><td colspan="2"><b>PROD. DATA:</b></td><td><b>PERCENT WGH</b></td></tr> <tr><td><b>PERCENT WGH40</b></td><td>Wxx%</td><td>68.75 g</td></tr> <tr><td><b>CALCULATIONS8</b></td><td>pRef</td><td>100 %</td></tr> <tr><td><b>COUNTING13</b></td><td></td><td></td></tr> <tr><td>&lt;&lt;</td><td>Delete Load</td><td>v Store</td></tr> </table>	<b>PROD. DATA:</b>		<b>PERCENT WGH</b>	<b>PERCENT WGH40</b>	Wxx%	68.75 g	<b>CALCULATIONS8</b>	pRef	100 %	<b>COUNTING13</b>			<<	Delete Load	v Store						
<b>PROD. DATA:</b>		<b>PERCENT WGH</b>																					
<b>PERCENT WGH40</b>	Wxx%	68.75 g																					
<b>CALCULATIONS8</b>	pRef	100 %																					
<b>COUNTING13</b>																							
<<	Delete Load	v Store																					
5. Enter a name for the new data record (here: CHW01)	 <b>ABCDEF</b> soft key, <b>C</b> soft key <b>GHIJKL</b> soft key, <b>H</b> soft key <b>STUUVWX</b> soft key, <b>W</b> soft key 	<table border="1"> <tr><td colspan="2"><b>PROD. DATA:</b></td><td></td></tr> <tr><td><b>CHW01</b></td><td></td><td></td></tr> <tr><td>&lt;&lt;</td><td>&lt;</td><td>New</td></tr> </table>	<b>PROD. DATA:</b>			<b>CHW01</b>			<<	<	New												
<b>PROD. DATA:</b>																							
<b>CHW01</b>																							
<<	<	New																					
6. Store current Checkweighing parameters as a data record	<b>New</b> soft key	<table border="1"> <tr><td colspan="2"><b>PROD. DATA:</b></td><td><b>NEW: KW01</b></td></tr> <tr><td><b>CHECKWEIGH</b></td><td>Setp= +</td><td>170.00 g</td></tr> <tr><td></td><td>Min = +</td><td>165.00 g</td></tr> <tr><td></td><td>Max = +</td><td>180.00 g</td></tr> <tr><td></td><td>Lim-=</td><td>0 %</td></tr> <tr><td></td><td>Lim+=</td><td>0 %</td></tr> <tr><td>&lt;&lt;</td><td>&lt;</td><td>Store</td></tr> </table>	<b>PROD. DATA:</b>		<b>NEW: KW01</b>	<b>CHECKWEIGH</b>	Setp= +	170.00 g		Min = +	165.00 g		Max = +	180.00 g		Lim-=	0 %		Lim+=	0 %	<<	<	Store
<b>PROD. DATA:</b>		<b>NEW: KW01</b>																					
<b>CHECKWEIGH</b>	Setp= +	170.00 g																					
	Min = +	165.00 g																					
	Max = +	180.00 g																					
	Lim-=	0 %																					
	Lim+=	0 %																					
<<	<	Store																					
7. Confirm	<b>Store</b> soft key	<table border="1"> <tr><td colspan="2"><b>PROD. DATA:</b></td><td><b>Data stored</b></td></tr> <tr><td><b>CHW01</b></td><td>Setp= +</td><td>170.00 g</td></tr> <tr><td><b>PERCENT WGH40</b></td><td>Min = +</td><td>165.00 g</td></tr> <tr><td><b>CALCULATIONS8</b></td><td>Max = +</td><td>180.00 g</td></tr> <tr><td><b>COUNTING13</b></td><td>Lim-=</td><td>0 %</td></tr> <tr><td></td><td>Lim+=</td><td>0 %</td></tr> <tr><td>&lt;&lt;</td><td>Delete Load</td><td>v Change</td></tr> </table>	<b>PROD. DATA:</b>		<b>Data stored</b>	<b>CHW01</b>	Setp= +	170.00 g	<b>PERCENT WGH40</b>	Min = +	165.00 g	<b>CALCULATIONS8</b>	Max = +	180.00 g	<b>COUNTING13</b>	Lim-=	0 %		Lim+=	0 %	<<	Delete Load	v Change
<b>PROD. DATA:</b>		<b>Data stored</b>																					
<b>CHW01</b>	Setp= +	170.00 g																					
<b>PERCENT WGH40</b>	Min = +	165.00 g																					
<b>CALCULATIONS8</b>	Max = +	180.00 g																					
<b>COUNTING13</b>	Lim-=	0 %																					
	Lim+=	0 %																					
<<	Delete Load	v Change																					
8. Exit data record display	<b>&lt;&lt;</b> soft key	<table border="1"> <tr><td colspan="2">Max 6200 g</td><td>d= 0.01g</td></tr> <tr><td colspan="3">+ 169.48g</td></tr> <tr><td colspan="2">CHCKW.: n = 1</td><td>Setp= +170.00 g</td></tr> <tr><td>Cal</td><td>ProDat</td><td>Param. Net Show</td></tr> </table>	Max 6200 g		d= 0.01g	+ 169.48g			CHCKW.: n = 1		Setp= +170.00 g	Cal	ProDat	Param. Net Show									
Max 6200 g		d= 0.01g																					
+ 169.48g																							
CHCKW.: n = 1		Setp= +170.00 g																					
Cal	ProDat	Param. Net Show																					

## Basic Settings

### Keypad

You can assign different functions to the **[CF]** key for deleting input and applications.

When you delete applications, you can delete either all data stored for that application or just selected data.

#### CF function in application

When you delete input, you can either delete all the data input in a field, or only the last character entered.

#### CF function for inputs

You can block key functions; you can choose whether to block all keys (except **[ON]** and **[SETUP]**) or just the alphanumeric keys.

#### Block key functions

### Display

You can configure the display for your individual needs.

Characters can be displayed in black on white or vice versa.

#### Background



You can blank out either the bar graph or the text line or both

#### Digit size

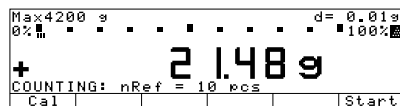

10mm + bar graph + text display



13mm + bar graph

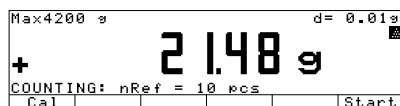

13mm + text display

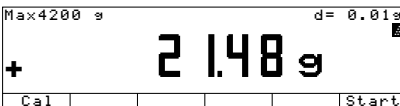

13mm

You can blank out the display of application symbols

#### Application symbols

### Printout Configuration

Many of the application programs require values to be input for initialization. You can configure the balance to print all initialization values, or only the main values, automatically as soon as they are set.

#### Auto print upon initialization

You can have weighed and calculated values printed without an ID code (16 characters) or with an ID code designation (22 characters)

**Line format.** See also "Data Output Functions."

You can have the ISO/GLP/GMP-compliant printout generated each time, only after calibration/adjustment or never. See also "Data Output Functions."

#### ISO/GLP/GMP printout

### Auto-Start Application when the Balance is Switched On

You can configure the balance so that, when you turn on the balance, the application that was running before the balance was turned off is started automatically.

#### Auto-Start app. when power goes on

## “FlexPrint” Printout Function

### Purpose





The YAD02IS “Nice Label Express” software from Sartorius enables you to load user-defined label printing formats and the corresponding print instruction files in your balance. This software lets you connect any of a number of printers, equipped with a variety of printer fonts, to the RS-232 interface on your balance.

### Features

With the “FlexPrint” option activated:

- Print command generates configured printout (if print instruction file exists; see table, next page). Print command generates default printout (if print instruction file does not exist).
- The function that generates an automatic printout upon initialization of an application cannot be used. Initialization data can be output only to a print instruction file.

The following items are output only as standard printouts:

- Calibration/adjustment
- SETUP printouts
-  key in “Identifier:” display page
-  key on “Product data memory:” display page
-  on “Parameter” display page for “Checkweighing” application: print function carried out
- MR function carried out when  is pressed during evaluation (info window) in Totalizing and Statistics applications.
- To recall the file names, Software ID and version numbers, for FlexPrint, see the section on “Basic Settings,” “Info Display.”

- Printout for legal metrology: Weight blocks (special weight value formats that are acceptable in legal metrology) are designated by the following line, which is printed in both header and footer and cannot be edited:

“----- CE [M] -----”

Examples of Weight Block Printouts

Without tare:

```
----- CE [M] -----
N +          348.65 kg
----- CE [M] -----
```











With tare:

```
----- CE [M] -----
G +          459.70 kg
N +          348.65 kg
T1 +         111.05 kg
----- CE [M] -----
```

Balance tare (2nd tare memory):

```
----- CE [M] -----
G +          124.45 kg
N +          100.00 kg
T1 +           24.00 kg
T2 +           0.45 kg
----- CE [M] -----
```

### Preparation

- Turn on the balance: press the  key
- Configure FlexPrint in Setup: press the  key
- Select application menu: **App**
- Select **Basic settings**: press  soft key repeatedly and then  soft key
- Select **Printout**: press  soft key twice and then  soft key
- Select **FlexPrint**: press  soft key 3 times and then  soft key
- Select **On**: press  soft key and then  soft key

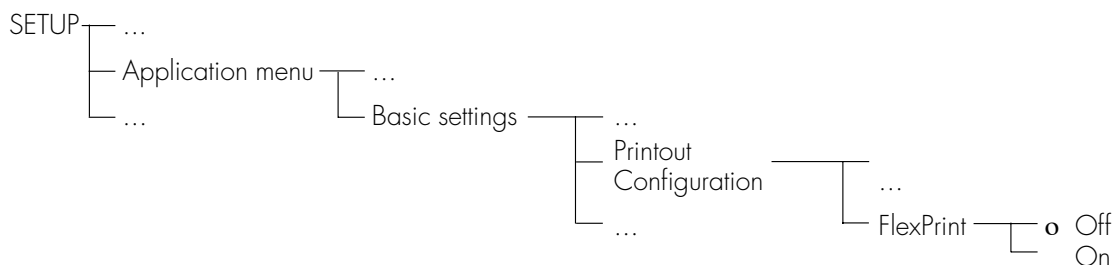



o = factory setting





- Save settings and exit Setup: press  soft key

Printouts generated using the "Nice Label Express" software are divided into two groups:

**Print events with all applications except differential weighing:**

Event	Explanation	File name for event group:
1.  key with individual values	Print key	PPRINT
2.  key with text input	Input and  key	PDIRECT
3. GLP /GMP header	GLP header	PGMPHEAD
4. GLP /GMP footer	GLP footer	PGMPFOOT
5. Results, Application 1	Animal weighing, MR-CF	PA1RES
6. Results, Application 2	OK values, time-controlled print	PA2RES
7. Results, Application 3	MR, MR-CF	PA3RES
8. Components, Application 1	M+ printout	PA1COMP
9. Components, Application 3	M+/M- printout	PA3COMP

**Print events with differential weighing:**

Event	Explanation	File name for event group:
1.  key with individual values	Print key	PPRINT
2.  key with text input	Input and  key	PDIRECT
3. GLP /GMP header	GLP header	PGMPHEAD
4. GLP /GMP footer	GLP footer	PGMPFOOT
5. Automatic printout after tare/initial weighing	Tare soft key, initial weight	PDCOMP
6. Differential weighing, results	Automatic after backweighing Print key while results displayed	PDRES
7. Catalog printout sample	Print key on value/result page	PDSAMP
8.  key with statistics app.	Print key on statistics page	PDSTAT

## Additional Functions (in the Balance Menu)

### Password

You can block access to parameter settings in the Setup menu and to the ID code input function, as well as to the exact calibration weight, by assigning a password.

Enter the password under Setup: Input. See "Configuring the Balance" for a detailed description.

### Protecting Menu Parameters

In the Setup menu, you can define whether menu parameters are

- accessible for changes (**Change parameters, [8-1-1]**)
- can be read only (**Read parameters, [8-1-2]**)

### Acoustic Signal

An acoustic signal is emitted when you press a key. When the key pressed is allowed, the signal is a single beep-tone; when it is not allowed, this is signaled by a double-beep (key does not initiate a function). In the Setup menu, you can configure whether

- the acoustic signal should sound (**On, [8-2-1]**)
- the acoustic signal should not sound (**Off, [8-2-2]**)

### Universal Switch for Remote Control

You can connect an external universal switch to the interface port of your balance (e.g., a foot switch) for remote control of the functions listed below. In the Setup menu, you can configure which function is to be controlled via remote switch:

- 1 (**Print key, [8-4-1]**)
- 2 (**Tare key, [8-4-2]**)
- 3 (**Cal key, [8-4-3]**)



- 4 (**F1 function key, [8-4-4]**)
- 5 (**CF key, [8-4-5]**)
- 6 (**F2 function key, [8-4-6]**)
- 7 (**Bar code scanner, PC keyboard [8-4-7]** special adapter necessary/ Order no. YCC01-0024/M01)

### "PC Keyboard" Functions

The alphanumeric key codes implemented are for a German keyboard layout only ("Z" in the first row instead of "Y", for example). Some of alphanumeric keys are used with the [Shift] key:

a-z, A-Z, 0-9, space  
 ",. \+ # < > ! " \$ % & / ( ) ; = : \_ ? \* "

Function keys:

PC keyboard	Balance
F1	<b>TARE</b> key
F2	<b>SETUP</b> key
F3	Soft key 6
F4	Soft key 5
F5	Soft key 4
F6	Soft key 3
F7	Soft key 2
F8	Soft key 1
F9	Display
F10	Escape
F11	 key (print)
F12	<b>TARE</b> key
Return	Soft key 1
Backspace	Escape
Up cursor	Soft key 3
Left cursor	Soft key 4
Down cursor	Soft key 2
Right cursor	Soft key 1
POS1 (HOME)	Soft key 6
ESC	Escape
PRINT	 key

The "Num Lock" and "Caps Lock" keys are not supported. There is no country-specific option for switching these keys to a different function.

### Display Backlighting

You can have the display backlit for improved readability of displayed values. In the Setup menu, you can configure whether the

- display backlighting is on (**On, [8-5-1]**)
- display backlighting shuts off automatically after 4 minutes without activity (**Auto off after 4 minutes, [8-5-3]**)

### Power-On Mode

You can configure the balance so that when a power supply is connected,

- the balance is off (**Off/on/standby [8-6-1]** or **Off/on [8-6-2]**)
- the balance switches on automatically (**Auto on, [8-6-4]**)

You can also set the configurations so that when the balance is turned off after use, it is

- off (**Off/on, [8-6-2]**) (not possible with balances that have a weighing capacity  $\geq 16$  kg)
- in the standby mode (**Off/on/standby, [8-6-1]**)

After you turn on the balance, a self-test of the functions is run (**TEST** is displayed in the text line; the bar graph is shown)

After the self-test has been completed, the weighing range of the balance is displayed (line for metrological data shows different increments)

### Automatic Shutoff

When parameter **[8-6-2]** is selected in the Setup menu, you can configure whether





- the balance shuts off automatically after 4 minutes without use (**After 4 minutes, [8-7-1]**)
- automatic shutoff is deactivated (**Off, [8-7-2]**)

### Interface Port Input/Output





You can connect a checkweighing display and a remote universal switch to the interface port (factory setting).

When you connect a remote universal switch, you need to change the following parameters.

#### Pin Assignments for the Female Interface Connector

Pin	Input Function [8-8-1]	Output Function [8-8-2]
15	 key	Remote universal switch (see below)
16	 key	Control output port 1: lighter
17	 key	Control output port 2: equal
18	 key	Control output port 3: heavier
19	 key	Control output port 4: "set"

#### Remote Universal Switch

Function	Menu setting
 key	[8-4-1]
 key	[8-4-2]
 key	[8-4-3]
F1 Function key	[8-4-4]
 key	[8-4-5]
F2 Function key	[8-4-6]
Bar code scanner, PC keyboard	[8-4-7]

See "Pin Assignment Chart" in the chapter entitled "Overview" for detailed information.

### Printing an ISO/GLP/GMP-compliant Record

In the Setup menu, you can configure whether

- no ISO/GLP/GMP-compliant record will be printed (**Off**, [8-10-1])
- an ISO/GLP/GMP-compliant record will be printed only after calibration/adjustment (**Only for calibration/adjustment**, [8-10-2])
- every printout will be an ISO/GLP/GMP-compliant record (**Always on**, [8-10-3])

### Undoing All Parameter Changes – Reset Function

There is a factory setting for each parameter. In the Setup menu, you can configure whether

- factory settings will be restored after exiting Setup (**Factory settings**, [9-1-1])

## Combining Applications

The following table summarizes the possibilities for combination of the application programs described here. Each line stands for one combination. The weighing function is generally available, and does not have to be combined with a calculating function.

Application 1 (calculating function)	Application 2 (checkweighing function)	Application 3 (documenting function)
Counting	–	Totalizing
Counting	–	Formulation
Counting	–	Statistics
Weighing in percent	–	Totalizing
Weighing in percent	–	Formulation
Weighing in percent	–	Statistics
Animal weighing	–	Totalizing
Animal weighing	–	Statistics
Recalculation	–	Totalizing
Recalculation	–	Statistics
Calculation	–	Totalizing
Calculation	–	Formulation
Calculation	–	Statistics
Density determination	–	Statistics
Density determination	Time-controlled functions	Statistics
–	Checkweighing	Totalizing
–	Checkweighing	Formulation
–	Checkweighing	Statistics
Counting	Checkweighing	Totalizing
Counting	Checkweighing	Formulation
Counting	Checkweighing	Statistics
Weighing in percent	Checkweighing	Totalizing
Weighing in percent	Checkweighing	Formulation
Weighing in percent	Checkweighing	Statistics
Recalculation	Checkweighing	Totalizing
Recalculation	Checkweighing	Statistics
Calculating	Checkweighing	Totalizing
Calculating	Checkweighing	Formulation
Calculating	Checkweighing	Statistics
–	Time-controlled functions	Totalizing
–	Time-controlled functions	Formulation
–	Time-controlled functions	Statistics
Counting	Time-controlled functions	Totalizing
Counting	Time-controlled functions	Formulation
Counting	Time-controlled functions	Statistics
Weighing in percent	Time-controlled functions	Totalizing
Weighing in percent	Time-controlled functions	Formulation
Weighing in percent	Time-controlled functions	Statistics
Animal weighing	Time-controlled functions	Totalizing
Animal weighing	Time-controlled functions	Statistics
Recalculation	Time-controlled functions	Totalizing
Recalculation	Time-controlled functions	Statistics
Calculating	Time-controlled functions	Totalizing
Calculating	Time-controlled functions	Formulation
Calculating	Time-controlled functions	Statistics

## Examples of Application Combinations

### Example 1: Checkweighing with statistical evaluation

You want to check a piece count, and have the results that lie within the tolerance range statistically evaluated and printed as a ISO/GLP-compliant record.

Settings (changes in the factory settings required for this example):

Setup: App: Application 1: Counting

Setup: App: Application 2: Checkweighing

Setup: App: Application 3: Statistics: Automatic storage: On, first value at stability

Setup: App: Application 3: Statistics: Source of data for auto storage: Application 2

Setup: App: Application 3: Statistics: Evaluated value: Calculated

Setup: App: Application 3: Statistics: Evaluation mode, MR function: Intermediate evaluation, display+print

Setup: App: Basic application: Printout configuration: ISO/GLP/GMP printout: Always

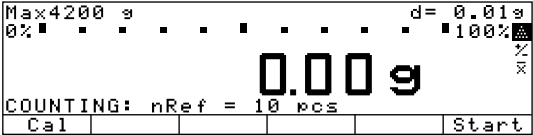
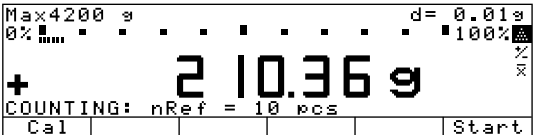
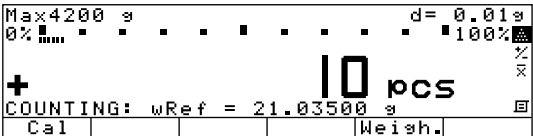
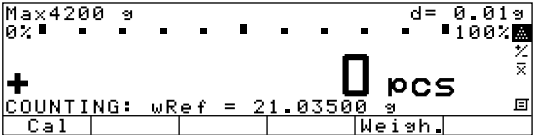
Step	Key (or instruction)	Display/Output
1. If necessary: turn on the balance and enter the settings given above		
2. Place reference sample quantity on the balance	Place parts on the balance	
3. Initialize the balance	<b>Start</b> soft key	 <pre> ----- 18.03.1997    09:41       SARTORIUS Mod.         LA4200S Ser. no.     60419914 Ver. no.     01-35-16 ID ----- L ID nRef         10 pcs wRef        21.03500 g nDef         0 n            1 Cnt +       10 pcs           </pre>
4. Remove reference sample quantity	Unload the balance	

5. Initialize Checkweighing  
Toggle to Checkweighing

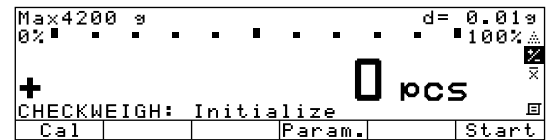

6. Enter target, minimum and maximum values (here: target: 10 pcs; minimum: 7 pcs; maximum: 12 pcs)

Param. soft key  
1 0, ↓ soft key  
7, ↓ soft key  
1 2

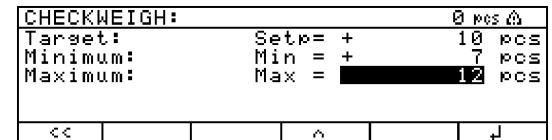

7. Store input

↓ soft key



Setp	+	10 pcs
Min	+	7 pcs
Max	+	12 pcs

8. Determine first unknown quantity

Place uncounted parts on the balance

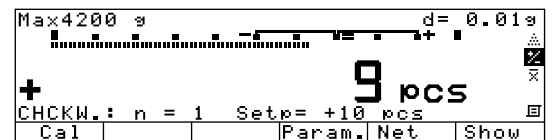

9. Toggle to Statistics

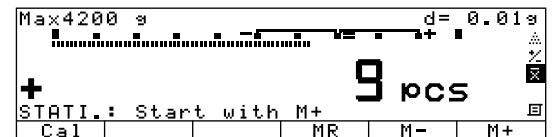

10. Initialize automatic storage

M+ soft key

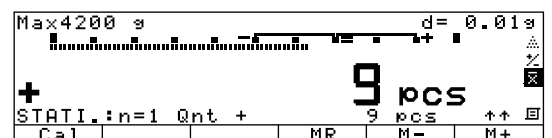

n		1
Qnt	+	9 pcs

11. Determine further unknown quantities

Place parts to be counted on the balance

Printout is generated automatically

12. End weighing series  
Statistics are evaluated  
Final GLP printout is generated

n		4
Avg.	+	10.0 pcs
s	+	0.8 pcs
srel	+	8.00 %
Total	+	40 pcs
Min	+	9 pcs
Max	+	11 pcs
Diff	+	2 pcs

13. Delete initialization of the last application

-----  
18.03.1997 10:26  
Name:  
-----

## Practical Example 2: Animal weighing with statistics

Determine the weights of 7 mice; generate and print a statistical evaluation.

Settings (changes in the factory settings required for this example):

Setup: App: Application 1: Animal weighing: Start: Automatic

Setup: App: Application 1: Animal weighing: Printout: Off

Setup: App: Application 3: Statistics: Automatic storage: On, first value at stability

Setup: App: Application 3: Statistics: Minimum load for automatic storage: 100 digits

Setup: App: Application 3: Statistics: Evaluated value: Calculated

Setup: App: Application 3: Statistics: Evaluation mode, MR function: Intermediate evaluation, display+print

Setup: App: Extra function(F4): Man. store in app. 3 memory (M+)

Step	Key (or instruction)	Display/Output
1. Prepare a container (cage)	Place empty cage on the balance	 <p>Max4200 g d= 0.01g 0% 100% + 432.06 g ANIMAL WEIG.: mDef = 10 Cal M+ Start</p>
2. Tare the balance	TARE	 <p>Max4200 g d= 0.01g 0% 100% 0.00 g ANIMAL WEIG.: mDef = 10 Cal M+ Start</p>
3. Enter number of subweighing operations for averaging	2 0	 <p>Max4200 g d= 0.01g 0% 100% 20 Mul mDef S ID</p>
4. Save number	mDef soft key	 <p>Max4200 g d= 0.01g 0% 100% 0.00 g ANIMAL WEIG.: mDef = 20 Cal M+ Start</p>
5. Weigh the first animal	Place 1st animal in cage	weight value fluctuates due to animal activity  <p>Max4200 g d= 0.01g 0% 100% ANIMAL WEIG.: mDef = 20 Cal M+ Start</p>
6. Start automatic animal weighing	Start soft key	 <p>Max4200 g d= 0.01g 0% 100% + ANIMAL WEIG.: mDef = 20 Cal M+ Start</p>

Step	Key (or instruction)	Display/Output
The balance delays starting the subweighing operation until three successive subweights lie within the range defined for a "calm" animal	When this criterion is met, the subweighing series begins	<p>Max4200 g d= 0.01g 0% 100% + ANIMAL WEIG.: m = 20 Cal M+ 19 18 i</p>
After 20 subweighing operations (n: number of current subweigh x-Net: arithm. average, net value)		<p>Max4200 g d= 0.01g 0% 100% + 31.70g ANIMAL WEIG.: x-Net Cal M+ xRes Restar</p>
7. Store result and activate autom. storage (automatic storage is not active here*)	M+ soft key	<p>n 1 x-Net + 31.70 g</p>
8. Unload the balance	Remove animal from cage	<p>Max4200 g d= 0.01g 0% 100% 0.00g ANIMAL WEIG.: mDef = 20 Auto Cal M+</p>
9. Weigh all 7 animals	Place one animal after another in the cage	<p>Max4200 g d= 0.01g 0% 100% ANIMAL WEIG.: mDef = 20 Cal M+ Start</p>
The next weighing operation starts automatically; the result is stored automatically in the Statistics program		<p>Max4200 g d= 0.01g 0% 100% + ANIMAL WEIG.: mDef = 20 Cal M+ Start</p>
10. View display, then print	 MR soft key 	<p>STATI.: Calculated: n = 7 Calculated: <math>\bar{x}</math> = + 45.347 g Calculated: s = + 23.794 g Calculated: srel = + 52.47 % Calculated: <math>\Sigma</math> = + 317.43 g &lt;&lt; v &gt;&gt;</p>
* The first time you store a value after the Statistics memory has been cleared, storage must be initiated manually, by pressing the M+ soft key. The subsequent values in the statistics series will be stored automatically.		<p>n 6 Avg. + 45.347 g s + 23.794 g srel + 52.47 % Total + 317.43 g Min + 12.85 g Max + 78.99 g Diff + 66.14 g 30.01.1997 08:41</p>

### Practical Example 3: Calculation with statistics

Statistically determine the average gsm weight of A4 paper and document the result with a printout of the results on 10 samples. The gsm weight is a product of the division of the weight by the surface area. One A4 sheet has a surface area of  $0.210 \text{ m} \times 0.297 \text{ m} = 0.06237 \text{ m}^2$ .

Settings (changes in the factory settings required for this example):

Setup: App: Application 1: Calculation: Decimal places in calculated result: 3 decimal places

Setup: App: Application 3: Statistics: Automatic storage: On, first value at stability

Setup: App: Application 3: Statistics: Evaluated value: Calculated

Setup: App: Application 3: Statistics: M+/-M- function, then tare: On

Step	Key (or instruction)	Display/Output
1. If necessary: turn on the balance and enter the settings given above		
2. Clear Statistics memory and equation memory, if necessary		
3. Place a container for the paper on the balance and tare		
4. Toggle to Calculation		
5. Select equation input	<b>Equat.</b> soft key	
6. Enter equation (here: EQUAT.=W÷÷0.06237)	<b>Weight</b> soft key ÷ soft key 0 . 0 6 2 3 7	
7. Quit the equation input mode	<b>Start</b> soft key	
8. Toggle to Application 3: Statistics		

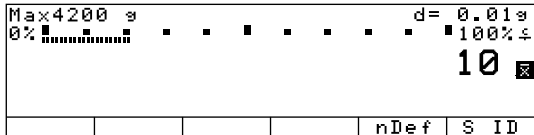
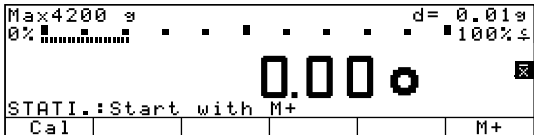
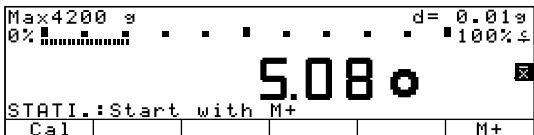
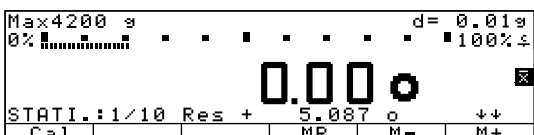
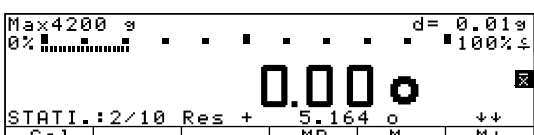
Step	Key (or instruction)	Display/Output
9. Enter no. of samples for Statistics (here: 10 samples)	<span style="border: 1px solid black; padding: 2px;">1</span> <span style="border: 1px solid black; padding: 2px;">0</span>	
10. Store number no. of samples	<b>nDef</b> soft key	
11. Place one sheet of A 4 paper in the container	Place load on balance	
12. Store measured value	<b>M+</b> soft key	
13. Place the next sheet of paper in the container (value is stored automatically)	Place load on balance	
14. Repeat step 13 eight times		<div style="border: 1px solid black; padding: 5px; margin-bottom: 10px;"> <p style="text-align: right;">EQUAT. =W/0.06237</p> <p style="text-align: right;">nDef                    10</p> <hr style="border-top: 1px dashed black;"/> <p style="text-align: right;">27.01.1997            15:04</p> <p style="text-align: right;">n                        1</p> <p style="text-align: right;">Res    +            5.08 o</p> </div> <div style="border: 1px solid black; padding: 5px;"> <p style="text-align: right;">n                        10</p> <p style="text-align: right;">Res    +            4.99 o</p> <hr style="border-top: 1px dashed black;"/> <p style="text-align: right;">n                        10</p> <p style="text-align: right;">Avg.    +            5.0598 o</p> <p style="text-align: right;">s        +            0.1052 o</p> <p style="text-align: right;">srel    +            1.04 %</p> <p style="text-align: right;">Total   +            51.17 o</p> <p style="text-align: right;">Min     +            4.81 o</p> <p style="text-align: right;">Max     +            5.16 o</p> <p style="text-align: right;">Diff    +            0.38 o</p> <p style="text-align: right;">27.01.1997            15:07</p> <hr style="border-top: 1px dashed black;"/> </div>
	The statistical evaluation is printed automatically	

## Data Output Functions

There are 3 options for data output:

- Output to the display and control unit
- Output to a printer (generate a printout)
- Output to a peripheral device (e.g., computer) via the interface port

### Output to the Display and Control Unit

The display is divided into 9 sections. Information about the balance, the application being used and the sample weighed is output in the following sections:

- Line for metrological data
- Bar graph
- Plus/minus sign, stability symbol display
- Measured value line
- Weight unit display
- Data in tare memory; calculated value
- Application symbol display
- Text line
- Soft key labels

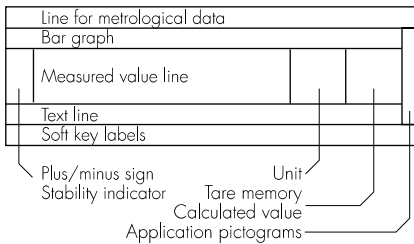

Line for Metrological Data (on balances verified for legal metrology)

This line shows:

- Max 4200 g** - Maximum balance capacity (e.g., 4,200 g)
- Min 0.5 g** - Minimum balance capacity; the weight must not go below this limit when the balance is used in legal metrology
- e = 0.1 g** - Verification interval of the balance; irrelevant if the balance is not used in legal metrology (e.g., 0.1 g)
- d = 0.01 g** - Readability: Indicates the actual scale interval (display increment of the balance) (e.g., 0.01 g)

Bar Graph (overview display)

In the bar graph, weighing results are displayed either

- 0% - as a percentage of the maximum balance capacity, or
- 0% - in relation to a target value, with tolerance limits indicated.

You can turn off (blank) the bar graph display (Setup: App: Basic settings: Display: Digit size: 13 mm + text display or 13 mm)

Plus/Minus Sign, Stability Symbol

This section shows:

- "Busy" symbol
- + -** - Plus or minus sign
- Zero symbol (indicating the scale has been zeroed)

## Measured Value Line

This line shows:

- |  |   |
|--|---|
| <p><b>125.03</b></p> <p><b>35</b></p> <p><b>=W* 18.3*0.9</b></p> | <ul style="list-style-type: none"> <li>- The current weight value (bordered values are invalid in legal metrology)</li> <li>- Calculated values (e.g., piece count)</li> <li>- User input (e.g., lot number, equation)</li> </ul> |
|--|---|

## Weight Unit Display

This section shows:

- |                                    |   |
|------------------------------------|---|
| <p><b>kg</b></p> <p><b>PCS</b></p> | <ul style="list-style-type: none"> <li>- The current weight unit (e.g., kg)</li> <li>- Designation of other values (e.g., "pcs")</li> </ul> |
|------------------------------------|---|

## Tare Memory, Calculated Value

This section shows:

- |   |   |
|---|---|
| <p><b>▲</b></p> <p><b>NET1 NET2</b></p> | <ul style="list-style-type: none"> <li>- Indication that value is calculated (not valid in legal metrology)</li> <li>- Indication that the tare memory contains application data</li> </ul> |
|---|---|

## Application Symbols

This column shows:

- |   |   |
|---|---|
| <p><b>R1</b> <b>▲</b> <b>⊗</b> <b>⊙</b> <b>⊚</b></p> <p><b>⊘</b> <b>⊙</b></p> <p><b>Σ</b> <b>⬇</b> <b>⊗</b></p> <p><b>⊙</b></p> <p><b>⊚</b></p> | <ul style="list-style-type: none"> <li>- Symbol for Application 1 (toggling between weight units, counting, weighing in percent, animal weighing, calculation, recalculation, density)</li> <li>- Symbol for Application 2 (checkweighing, time-controlled functions)</li> <li>- Symbol for Application 3 (totalizing, formulation, statistics)</li> <li>- Symbol for current print job</li> <li>- Symbol for ISO/GLP printout</li> </ul> |
|---|---|

## Text Line

This line contains:

- |   |   |
|---|---|
| <p><b>COUNTING: nRef = 10 pcs</b></p> <p><b>Ref.wt. too light</b></p> | <ul style="list-style-type: none"> <li>- Explanatory text about the application program (e.g., about "Counting")</li> <li>- Explanation of error codes</li> </ul> |
|---|---|

## Soft Key Labels

This line shows

- |  |   |
|--|---|
| <p><b>Cal</b> <b>PT1/T1</b> <b>S</b> <b>ID</b> <b>M+</b></p> <p><b>&lt;&lt;</b> <b>&lt;</b> <b>^</b> <b>v</b> <b>&gt;</b> <b>↓</b></p> | <ul style="list-style-type: none"> <li>- Texts (abbreviations) to indicate the function assigned to each key</li> <li>- Symbol for selecting and confirming parameter settings (see also "Operating Design")</li> </ul> |
|--|---|

## Balance Information

In the Setup menu, you can select **Setup: Info** for a display of balance information. The display includes:

SETUP	INFO
Version no.:	01-35-16
Bal. ver. no.:	00-20-13
Model:	LA5200P
Serial no.:	70906913
<<	

- Software version number
- Balance version number
- Balance model
- Balance serial number

## Printing a Data Record

### Purpose

You can generate a printout of weights, other measured values and identification numbers for documentation purposes. You can format the printout to meet individual requirements.

## Available Features

### Print manually/automatically:

To print the information contained in the measured value line (weight readout, calculated value, numeric input, alphabetic input)

Line format: You can configure a data ID code of up to 6 characters for each of the values printed; this data ID code is printed at the beginning of the line

Sample ID: You can configure an extra line for identification of each weighed or calculated value

### Print application parameters:

You can generate a printout of the values configured for initialization of an application before printing the measured results

### ISO/GLP-compliant printout:

To print out parameters relating to weighing conditions

Auto print: To have a printout generated automatically when certain conditions are met, e.g., time elapsed, stability reached, etc.

Print animal weights: For an automatic printout of animal weight, or of animal weight plus calculated weight after averaging

Print checkweighing results: for automatic printout of a weight when it lies within preset limits at stability

Print with time-controlled functions: for automatic printout of weights after a preset time period has elapsed or at a defined time

Printout of intermediate or final evaluation for totalizing, formulation and statistics by pressing the **MR** soft key

Setting a Printout Acceptable for Legal Metrology

You can configure the balance menu to generate data records on a Sartorius printer that are acceptable for legal metrology (last digit specially identified):

- YDPO1IS:           **[ 5-5-4 ]**
- YDPO2:            **[ 5-5-5 ]**
- YDPO3             **[ 5-5-6 ]**
- YDPO1IS-Label   **[ 5-5-7 ]**
- YDPO2IS          **[ 5-5-10 ]**
- YDPO2IS-Label   **[ 5-5-11 ]**
- YDPO4IS          **[ 5-5-14 ]**
- YDPO4IS-Label   **[ 5-5-15 ]**

## Factory Settings

### Manual/auto print mode:

Individual printout on request, or automatic printing dependent on stability:

Manual with stability **[ 6-1-2 ]**

### Print basic application settings:

Printout of one or more initialization values for the current application: Off

### Line format:

ID code for weighed or calculated value; up to 6 characters:  
For other apps/GLP (22 characters)

### ISO/GLP/GMP printout:

Documentation of weighing conditions for every series of weighing operations: Off

### Auto print:

Automatic printout of weighed values:

No setting; see: Manual/auto print mode **[ 6-1-2 ]**

Stop auto print: not possible **[ 6-2-2 ]**

### Time-dependent auto print:

1 display update **[ 6-3-1 ]**

### Print animal weights:

Automatic printout of average or average and calculated values:  
Average weight only

### Print checkweighing:

Automatic printout of weight values within the checkweighing range at stability: Off

### Print time-controlled functions:

Function after time interval:  
Automatic printout

Evaluation of totalizing, formulation and statistics data:

Evaluation mode, **MR** function:  
Intermediate evaluation, print

- See “Configuring the Balance” for details on how to set parameters

### Print Manually/Automatically

The printout contains the current value in the measured value display (weight readout with weight unit; calculated value; numeric/alphabetic display)

Setting:

Setup: Menu: Print in weighing mode: Manual/auto print mode

### Examples

+	1530.000	g	Weight in grams
+	58.5620	oz t	Weight in Troy ounces
+	253	pcs	Piece count
+	88.23	%	Percentage
+	105.78	o	Calculated value

### Line Format

The current value displayed can be printed with a data ID code of up to 6 characters at the beginning of the line. You can use this data ID code, e.g., to designate a weight readout as a net weight (N) or a calculated value as a piece count (QNT)

Setting:



Setup: App: Basic settings: Printout configuration: Line format: For other apps./GLP (22 characters)

<b>ID</b>	<b>ABC123DEF456GH</b>	Identification number*
<b>L ID</b>	<b>ABC123DEF456GH</b>	Lot number (weighing series)*
<b>W ID</b>	<b>ABC123DEF456GH</b>	Weight set number*
<b>N</b>	<b>+ 1530.000 g</b>	Net value
<b>Qnt</b>	<b>+ 253 pcs</b>	Quantity
<b>Prc</b>	<b>+ 88.23 %</b>	Percentage
<b>Nom.</b>	<b>+ 2000.00 g</b>	Exact calibration weight

\* = only for ISO/GLP-compliant records

### Sample ID

You can have each weighed or calculated value that you print preceded by a line of text containing numbers and/or letters. You can either print this ID immediately as alphanumeric input (press ) or store it as the sample ID (**S ID** soft key) to be included on the next printout, if the "For other apps./GLP (22 characters)" setting is configured.

<b>S ID</b>	<b>ABC123DEF456GH</b>	Sample ID (with less than 15 characters)
	<b>ABC123DEF456GHI789JK</b>	Sample ID (with more than 14 characters)
<b>NUM</b>	<b>12345678</b>	 key (with less than 15 characters)
	<b>ABC123DEF456GHI789JK</b>	Numeric key input when  key pressed (with more than 14 characters)

### Print Application Parameters

You can generate a printout of one or more of the values configured for initialization of an application as soon as you initialize the balance. This can include such values as nRef, wRef, pRef, etc.

Setting:

Setup: App: Basic settings: Printout configuration: Autoprint upon initialization

<b>nRef</b>	<b>10 pcs</b>	Counting: Reference sample quantity
<b>wRef</b>	<b>1.23456 g</b>	Counting: Average piece weight
<b>pRef</b>	<b>80 %</b>	Weighing in percent: Reference percentage
<b>Wxx%</b>	<b>1200.00 g</b>	Weighing in percent: Reference weight
<b>mDef</b>	<b>10</b>	Animal weighing: Number of subweighs for averaging
<b>MuL</b>	<b>0.00347</b>	Animal weighing: Multiplication factor
<b>EQUAT.</b>	<b>=W*18.3*0.9</b>	Calculation: Equation for calculation
<b>Setp</b>	<b>+ 1000.035 g</b>	Checkweighing: Target weight
<b>Min</b>	<b>+ 981.054 g</b>	Checkweighing: Lower limit
<b>Max</b>	<b>+ 1020.063 g</b>	Checkweighing: Upper limit

<p>Auto Print</p> <p>You can have the weight readout printed automatically<sup>1</sup>. This printout can be generated after a certain number of display updates<sup>2</sup>; you can also configure whether or not the auto-print function is dependent on the stability parameter<sup>3</sup>. The display update frequency depends on both the model of the balance and the current operating status.</p> <p>Setting:</p> <p><sup>1</sup>Setup: Menu: Print in weighing mode: Manual/auto print mode</p> <p><sup>2</sup>Setup: Menu: Print in weighing mode: Time-dependent autoprint</p> <p><sup>3</sup>Setup: Menu: Balance functions: Stability range</p>	<pre> <b>N</b>      + 1530.00 g <b>S ID</b>   12345678901234 <b>Stat</b> <b>Stat</b>      L <b>Stat</b>      H           </pre>	<p>Net weight</p> <p>Sample ID</p> <p>Display blank</p> <p>Display underload</p> <p>Display overload</p>
<p>Print Animal Weights</p> <p>When using the animal weighing application, you can have the results printed automatically upon completion of the averaging process. You can also have both the weight and the calculated result printed.</p>	<pre> <b>mDef</b>          10 <b>Mul</b>          0.00347 <b>xNet</b> + 1530.00 g <b>xRes</b> + 5.30 o           </pre>	<p>Number of subweighs for averaging</p> <p>Multiplication factor</p> <p>Result of averaging</p> <p>Calculated result</p>
<p>Print: Calculation</p> <p>The calculation result is printed.</p>	<pre> <b>Res</b> + 693.88 o           </pre>	<p>Result of calculation with equation</p>
<p>Auto Print Checkweighing</p> <p>With the over/under checkweighing application, you can have the result printed automatically as soon as the weight lies within a defined range.</p>	<pre> <b>N</b>      + 1530.000 g <b>Setp</b>  + 1000.035 g <b>Min</b>   + 981.054 g <b>Max</b>   + 1020.063 g <b>N</b>      + 1010.147 g           </pre>	<p>Net weight</p> <p>Target weight</p> <p>Lower limit</p> <p>Upper limit</p> <p>"OK" values-printout</p>
<p>Print: Time-Controlled Functions</p> <p>If the "Automatic printout of values" parameter is set, the time and weight are printed.</p>	<pre> <b>Time:</b>      10:15:00 <b>N</b>      + 3150.00 g           </pre>	<p>Time that values were stored</p> <p>Net weight</p>
<p>Print: Totalizing, Formulation, Statistics</p> <p>The transaction or component counter is printed before the measured value. When an intermediate or final evaluation is printed, all results to that point are included.</p>	<pre> <b>n</b>          5 <b>Comp2+</b>    42.38 g <b>Total</b> + 8751.67 g <b>Tot.cpt+</b> 324.89 g <b>n</b>          5 <b>Avg.</b> + 33.0 pcs <b>s</b> + 3.2 pcs <b>srel</b> + 9.70 % <b>Total</b> + 165 pcs <b>Min</b> + 29 pcs <b>Max</b> + 37 pcs <b>Diff</b> + 8 pcs           </pre>	<p>Totalizing, statistics:</p> <p>Transaction counter</p> <p>Formulation:</p> <p>Weight, 2nd component</p> <p>Totalizing, statistics: Sum of all values</p> <p>Formulation: Total no. of components</p> <p>Statistics: Total no. of transactions</p> <p>Statistics: Average</p> <p>Statistics: Standard deviation</p> <p>Statistics: Variation coefficient</p> <p>Statistics: Sum of all values</p> <p>Statistics: Minimum</p> <p>Statistics: Maximum</p> <p>Statistics: Difference between maximum and minimum</p>

## 2nd Tare Memory/Identifier

Printout shows either

- Net value **N1**,
- Tare weight **T1**, or
- Manually entered tare value **PT1**

Up to 4 identifier lines can be included on the printout

```

N1          63.48 g
T1          138.73 g
PT1         150.00 g
ID1   Batch no. 1234
ID2   Eisenmeier GmbH
ID3    Screws: M4x6
ID4    Mr. Smith
    
```

Net val. with data in 2nd tare memory

```

Tare weight
Manually entered tare weight
Identifier 1
Identifier 2
Identifier 3
Identifier 4
    
```

## ISO/GLP-compliant Printout/Record

You can have the parameters pertaining to weighing conditions printed before (GLP header) and after (GLP footer) the values from the weighing series. These parameters include:

- Date
- Time at the beginning of a weighing series
- Balance manufacturer
- Balance model
- Model serial number
- Software version
- Lot number (weighing series no.)
- Time at the conclusion of the weighing series
- Field for operator signature

```

-----
17.01.1997      16:12
      SARTORIUS
Mod.          LA4200S
Ser. no.       60419914
Ver. no.       01-35-16
ID      12345678901234
-----
L ID 12345678901234
nRef          10 pcs
wRef          1.35274 g
Qnt  +         235 pcs
Qnt  +         4721 pcs
S ID 12345678901234
Qnt  +          567 pcs
    
```

```

Dotted line
Date/time
Balance manufacturer
Balance model
Balance serial number
Software vers. (display and control unit)
Balance ID no.
Dotted line
Weighing series no.
Application initialization value
Application initialization value
Counting result
Counting result
ID for counting result
Counting result
Dotted line
Date/time
Field for operator signature
Blank line
Dotted line
    
```

Operating the Balance with an ISO/GLP-capable Documentation Device (Printer)

ISO/GLP-compliant documentation requires a computer with special software. Contact Sartorius for a detailed description for creating this software.

```

-----
17.01.1997      16:13
Name:
-----
    
```

Record of Internal Calibration/Adjustment:

Setting:  
Setup: App: Basic settings:  
Printout configuration:  
ISO/GLP/GMP printout: Always

The record is output to a Sartorius YDPO3-OCE Data Printer or a computer.

End GLP printout:

- Press **[CF]**

End GLP printout while application is active:

This requires the following settings:  
Setup: App: Basic settings: Keypad:  
CF function in application: Clear only selected applications

- Press **[CF]**

> Text line: CF selected:  
clear application

- Press the **GLP** soft key

```

-----
17.01.1997      16:24
      SARTORIUS
Mod.          LA4200S
Ser. no.       60419914
Ver. no.       01-35-16
ID
-----
L ID 12345678901234
Internal calibration
Start:      manual
-----
Diff. +       0.006 g
Internal calibration
completed
Diff. +       0.000 g
    
```

```

Dotted line
Date/time
Balance manufacturer
Balance model
Balance serial number
Software vers. (display and control unit)
Balance ID no.
Dotted line
Weighing series no.
Calibration adjustment mode
Beginning mode for calibration/adjustment
Difference after calibration/adjustment
Confirmation of completed calibration/adjustment routine
Difference between current and target values after calibration
Dotted line
Date/time
Field for operator signature
Blank line
Dotted line
    
```

## Block Printout

You can have the results of a calibration/adjustment procedure printed out. You can configure whether the printout is generated as soon as the procedure is completed, or whether a number of calibration/adjustment procedures (up to 50) are collected for a block printout.

### Loading Stored Data:

Data for the block printout are stored in battery-backed memory. These data remain in memory for approx. 3 months after the equipment is disconnected from AC power. Make sure to generate a printout before disconnecting the equipment for a long period of time.

### Block Printout of Calibration/Adjustment Data

With the following Setup menu configuration, you can store the data from up to 50 calibration/adjustment procedures and have them printed on request:

- isoCAL printout [1-17-]  
**2 On request, from  
 record memory**

When the memory contains 50 data records:

- additional records are output automatically

If at least one block printout data record has been configured, the following soft keys are available after you press the **Cal** soft key:

- Info** The number of records is displayed in the text line
  - PrtPro** Print accumulated records
  - DelPro** Delete accumulated records; records can only be deleted after a printout has been generated.
- If a password has been assigned in the Setup: Input menu, you must enter either the configured password or the General Password before you can delete the records.

For internal calibration/adjustment, the initialization mode of the procedure is displayed in the **Start** line.

```
-----
13.05.1997      09:17
                SARTORIUS
Mod.           FC6CCE-H
Ser. no.       70419914
Ver. no.       01-35-16
ID
-----
```

GLP header

```
24.04.1997      12:03
Start:         manual
Diff. +        0.01 g
External calibration
                completed
```

List of Calibration/  
Adjustment Procedures:

Example 1:  
External calibration

```
25.04.1997      12:10
Start:         isoCAL/temp
Diff. +        0.01 g
Internal adjustment
                completed
Diff. +        0.00 g
```

Example 2:  
isoCAL triggered by difference  
in temperature

```
25.04.1997      18:30
Start:         Adj.time
Diff. +        0.01 g
Internal adjustment
                completed
Diff. +        0.00 g
```

Example 3:  
isoCAL at defined time

```
26.04.1997      9:37
Start:         manual
Diff. +        0.01 g
Internal adjustment
                completed
Diff. +        0.00 g
```

Example 4:  
Internal calibration/adjustment  
triggered manually

```
27.04.1997      11:53
Start:         Ext.cal.
W I D
Nom. + 2,000.00 g
Diff. +        0.01 g
External calibration
                completed
Diff. +        0.00 g
```

Example 5:  
External calibration/adjustment

```
-----
13.05.1997      09:17
Name:
-----
```

GLP footer

## Interface Description

### Purpose

Your Master<sup>PRO</sup> balance comes equipped with an interface port for connection to a computer or other peripheral devices.

You can use an on-line computer to change, start and/or monitor the functions of the balance and the application programs. The interface port also has four data output port lines for the over/under check-weighing program.

### ⚠ Warning When Using Pre-wired RS-232 Connecting Cables!

RS-232 cables purchased from other manufacturers often have incorrect pin assignments for use with Sartorius balances. Be sure to check the pin assignment against the chart below before connecting the cable, and disconnect any lines marked "Internally Connected" (e.g., pin 6). Failure to do so may damage or even completely ruin your balance and/or peripheral device.

## Available Features

Type of interface:	Serial interface
Operating mode:	Full duplex
Standard:	RS-232
Transmission rates:	150; 300; 600; 1,200; 2,400; 4,800; 9,600; 19,200 baud
Parity:	Space, odd, even
Character format:	1 start bit, 7-bit ASCII, parity, 1 or 2 stop bits
Handshake:	2-wire interface: via software (XON/XOFF); 4-wire interface: via hardware handshake lines (CTS/DTR)
Operating mode:	SBI, xBPI*
Network address*:	0, 1, 2, ..., 30, 31
Data output format of the balance:	16 or 22 characters

\* xBPI operating mode: 9,600 baud, 8 bits, odd parity, 1 stop bit  
Network address is only valid in the xBPI mode

### Factory Settings:

Transmission rate:	1,200 baud	[ 5-1-4 ]
Parity:	Odd	[ 5-2-3 ]
Stop bits:	1 stop bit	[ 5-3-1 ]
Handshake:	Hardware 1 character after CTS	[ 5-4-3 ]
Operating mode:	SBI	[ 5-5-1 ]
Network address:	0	[ 5-6-1 ]
Print manually/automatically:	Manual after stability	[ 6-1-2 ]
Stop automatic printing:	Not possible	[ 6-2-2 ]
Automatic printout, time-dependent:	After 1 display update	[ 6-3-1 ]
Tare after indiv. printout:	Off	[ 6-4-1 ]
Application initialization values:	Off	
Line format:	For other applications/GLP (22 characters)	

### Preparation

- See page 133 for the pin assignment chart

## Line Format (Data Output Format)

You can output the values displayed in the measured value line and the weight unit with or without a data ID code

Example: Without data ID code

**+ 253 pcs**

Example: With data ID code

**Qnt + 253 pcs**

Configure this parameter in the Setup menu (Setup: Basic settings: Printout configuration: Line format).

The output with data ID code has 16 characters; without data ID code, 22 characters.

## Output Format With 16 Characters

Display segments that are not activated are output as spaces. Characters without a decimal point are output without a decimal point.

The following characters can be output, depending on the characters displayed on the balance:

### Normal Operation

Position	1	2	3	4	5	6	7	8	9	10	11	12	13	14	15	16
	+	*	D	D	D	D	D	D	D	D	*	U	U	U	CR	LF
or	-	.	.	.	.	.	.	.	.	.	.	*	*	*		
or	*	*	*	*	*	*	*	*	*	*						
or					0	0	0	0	0	0						

- \*: Space
- D: Digit or letter
- U: Unit symbol
- CR: Carriage return
- LF: Line feed

### Special Codes

Position	1	2	3	4	5	6	7	8	9	10	11	12	13	14	15	16
	*	*	*	*	*	*	-	-	*	*	*	*	*	*	*	CR LF
or								H	H							
or								L	L							
or								C								

- \*: Space
- : Weight
- H: Overload
- H H: Overload in checkweighing
- L: Underload
- L L: Underload in checkweighing
- C: Calibration/adjustment

### Error Codes

Position	1	2	3	4	5	6	7	8	9	10	11	12	13	14	15	16
	*	*	*	E	r	r	*	*	/	#	#	#	*	*	*	CR LF

- \*: Space
- # # #: Error code number

Data output example: + 1255.7 g

Position	1	2	3	4	5	6	7	8	9	10	11	12	13	14	15	16
	+	*	*	*	1	2	5	5	.	7	*	g	*	*	CR	LF

- Position 1: Plus or minus sign or space
- Position 2: Space
- Position 3–10: Weight with a decimal point; leading zeros = space
- Position 11: Space
- Position 12–14: Unit symbol or space
- Position 15: Carriage return
- Position 16: Line feed

### Data Output With ID Code

When data with an ID code is output, the ID code consisting of 6 characters precedes the data with the 16-character format. These 6 characters identify the subsequent value.

1	2	3	4	5	6	7	8	9	10	11	12	13	14	15	16	17	18	19	20	21	22
						+	*	D	D	D	D	D	D	D	*	U	U	U	CR	LF	
*	*	*	*	*	-			.	.	.	.	.	.	.		*	*	*			
					*		*	*	*	*	*	*	*	*							
										0	0	0	0	0	0						

- I: ID code character<sup>1)</sup>
- \*: Space
- D: Digit or letter
- U: Unit symbol<sup>1)</sup> see "Toggling between Weight Units"
- CR: Carriage return
- LF: Line feed

<sup>1)</sup> depends on balance type; e.g., not all units and characters are available on balances verified for use in legal metrology

### Special Codes

1	2	3	4	5	6	7	8	9	10	11	12	13	14	15	16	17	18	19	20	21	22
S	t	a	t	*	*	*	*	*	*	*	*	-	-	*	*	*	*	*	*	CR	LF
												H	H								
												L	L								
												C									

- \*: Space
- : Weight
- H: Overload
- H H: Overload in checkweighing
- L: Underload
- L L: Underload in checkweighing
- C: Calibration/adjustment

### Error Codes

1	2	3	4	5	6	7	8	9	10	11	12	13	14	15	16	17	18	19	20	21	22
S	t	a	t	*	*	*	*	*	E	r	r	*	#	#	#	*	*	*	*	CR	LF

- \*: Space
- ###: Error code number

### ID code characters I<sup>1)</sup>

<b>Stat</b>	Status
<b>ID</b>	Identifier
<b>L ID</b>	Weighing series no.
<b>W ID</b>	Weight set number
<b>Nom.</b>	Exact calibration weight
<b>S ID</b>	Sample ID
<b>NUM</b>	Numeric input
<b>T1</b>	Application tare memory 1
<b>N</b>	Net weight (T1 = 0)
<b>N1</b>	Net weight (T1# 0)
<b>Qnt</b>	Quantity
<b>Prc</b>	Percentage
<b>nRef</b>	Reference sample quantity
<b>pRef</b>	Reference percentage
<b>wRef</b>	Average piece weight
<b>Wxx%</b>	Reference percentage weight
<b>mDef</b>	Target value for animal weighing
<b>Mul</b>	Multiplication factor for animal weighing
<b>x-Net</b>	Result in animal weighing
<b>x-Res</b>	Calculated result in animal weighing
<b>Res</b>	Result using equation (Calculation)
<b>Setp</b>	Target value for checkweighing
<b>Min</b>	Lower limit for checkweighing
<b>Max</b>	Upper limit for checkweighing
<b>Time</b>	Time that a value was stored
<b>Compxx</b>	No. of components in formulation
<b>Tot.cp</b>	Total weight in formulation
<b>n</b>	Transaction counter
<b>Total</b>	Sum of all values
<b>Avg</b>	Average in statistics
<b>s</b>	Standard deviation
<b>srel</b>	Variation coefficient
<b>Diff</b>	Difference between maximum and minimum

## Data Input Format

You can connect a computer to your balance to send commands via the balance interface port to control balance functions and applications.

The commands sent are control commands and may have different formats; e.g., control commands can have up to 26 characters. Each character must be transmitted according to the settings configured in the Setup menu for data transmission.

## Format for Control Commands

Format 1:	Esc	!	CR	LF				
Format 2:	Esc	!	#	_	CR	LF		
Format 3:	Esc	!	#	&	(max. 20 &)	&	_	CR LF
Format 4:	Esc	!		&	(max. 20 &)	&	_	CR LF

Esc:	Escape	_:	Underline (ASCII: 95)
!:	Command character	CR:	Carriage RETURN (optional)
#:	Number	LF:	Line FEED (optional)
&:	Number or letter	max:	depends on command character: i.e. parameter: once the max. length is reached, input received is cut off, rather than discarded as with keyboard input

## Format 1

!	Meaning
I	Weighing mode 1
L	Weighing mode 2
M	Weighing mode 3
N	Weighing mode 4
O	Block keys
P	Print
R	Unblock keys
S	Restart
T	Tare and zero
Z	Internal calibration/adjustment**
Q	Acoustic signal

## Format 2

!#	Meaning
f3	Zero
f4	Tare (without zeroing)
kF1	Soft key 1* Function depends ... on setting in application program
kF6	Soft key 6* Function depends ... on setting in application program
kF7	Function key
kF8	Function key
s3	Function key
x0	Perform internal calibration**
x1	Print balance model
x2	Print weighing platform serial number
x3	Print weighing platform software version
x4	Print display and control unit software version
x5	Print (GLP) balance ID number
x6	Print weight set ("inventory") number
x7	Print weighing series number

## Format 3 (not allowed in the Setup menu)

!#	Meaning
z5	Input (GLP) balance ID no. (20 characters max.)
z6	Input weight set ("inventory") number (14 characters max.)
z7	Input weighing series no. (20 characters max.)

## Format 4

!	Meaning
t	Text input in display

\* numbered from right to left

\*\* Internal calibration weight necessary

## Synchronization

During data communication between the balance and an on-line device (computer), messages consisting of ASCII characters are transmitted via the interface. For error-free data communication, the parameters for baud rate, parity, handshake mode and character format must be the same for both units.

You can set these parameters in the Setup menu so that they match those of the on-line device. You can also define parameters in the balance to make data output dependent on various conditions. The conditions that can be configured are described under each of the application program descriptions.

If you do not plug a peripheral device into the balance interface port, this will not generate an error message.

## Handshake

The balance interface (Sartorius Balance Interface = SBI) has transmit and receive buffers. You can define the handshake parameter in the Setup menu:

- Hardware handshake (CTS/DTR)
- Software handshake (XON, XOFF)

### Hardware Handshake

With a 4-wire interface, 1 more character can be transmitted after CTS (Clear to Send).

### Software Handshake

The software handshake is controlled via XON and XOFF. When a device is switched on, XON must be transmitted to enable any connected device to communicate.

When the software handshake is configured in the Setup menu, the hardware handshake becomes active after the software handshake.

The data transmission sequence is as follows:

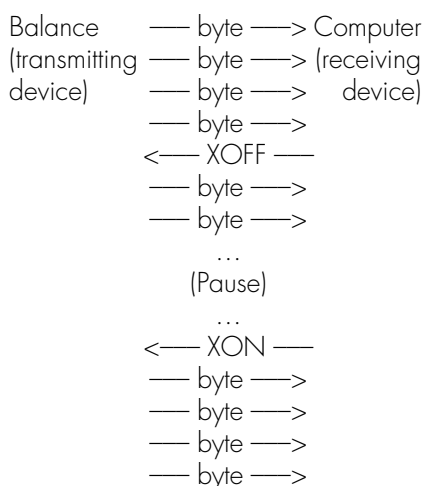

## Transmitting Device:

Once XOFF has been received, it prevents further transmission of characters. When XON is received, it re-enables the transmitting device to send data.

## Receiving Device:

XOFF is transmitted after the 26th character has been stored. To prevent too many control commands from being received at one time, XON is not transmitted until the buffer is almost empty.

## Activating Data Output

You can define the data output parameter so that output is activated either when a print command is received or automatically and synchronous with the balance display or at defined intervals (see application program descriptions and auto-print setting).

## Data Output by Print Command

The print command can be transmitted by pressing  or by a software command (Esc P).

## Automatic Data Output

In the "auto print" operating mode, data is output to the interface port without a print command. You can choose to have data output automatically at defined print intervals with or without the stability parameter. Whichever parameter you select, the data will be output as the readouts appear on the balance display. The display update frequency depends on both the model of the balance and the current operating status.

If you select the auto print setting, data will be transmitted immediately the moment you turn on the balance. In the Setup menu you can configure whether this automatic output can be stopped and started by pressing .

## Pin Assignment Chart

### Female Interface Connector:

25-position D-Submini, DB25S, with screw lock hardware for cable gland

### Male Connector Used:

(please use connectors with the same specifications):

25-pin D-Submini, DB25S, with integrated shielded cable clamp assembly (Amp type 826 985-1C) and fastening screws (Amp type 164 868-1)

### Pin Assignment Chart:

Pin 1:	Signal Ground
Pin 2:	Data Output (TxD)
Pin 3:	Data Input (RxD)
Pin 4:	Signal Return (TxD/RxD)
Pin 5:	Clear to Send (CTS)
Pin 6:	Internally Connected
Pin 7:	Internal Ground
Pin 8:	Internal Ground
Pin 9:	Reset _ In **)
Pin 10:	- 12 V
Pin 11:	+ 12 V
Pin 12:	Reset _ Out **)
Pin 13:	+ 5 V
Pin 14:	Internal Ground
Pin 15:	
Pin 16:	
Pin 17:	
Pin 18:	
Pin 19:	
Pin 20:	Data Terminal Ready (DTR)
Pin 21:	Supply Voltage Ground "COM"
Pin 22:	Not Connected
Pin 23:	Not Connected
Pin 24:	Supply Voltage Input + 1.5 ... 2.5 V
Pin 25:	+5 V

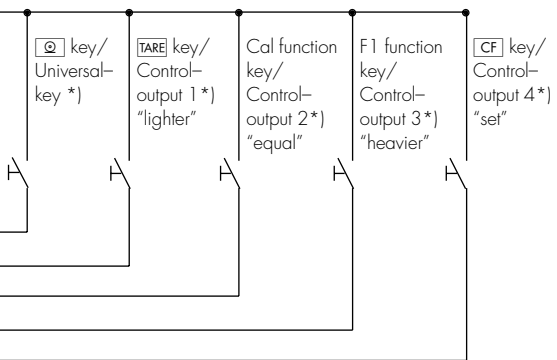

\*) = See "Additional Functions" for information on changing pin assignments

\*\*\*) = Hardware restart

## Cabling Diagram

- Diagram for interfacing a computer or different peripheral devices to the balance using the RS-232/V24 standard and cables up to 15 m (50 ft.) long

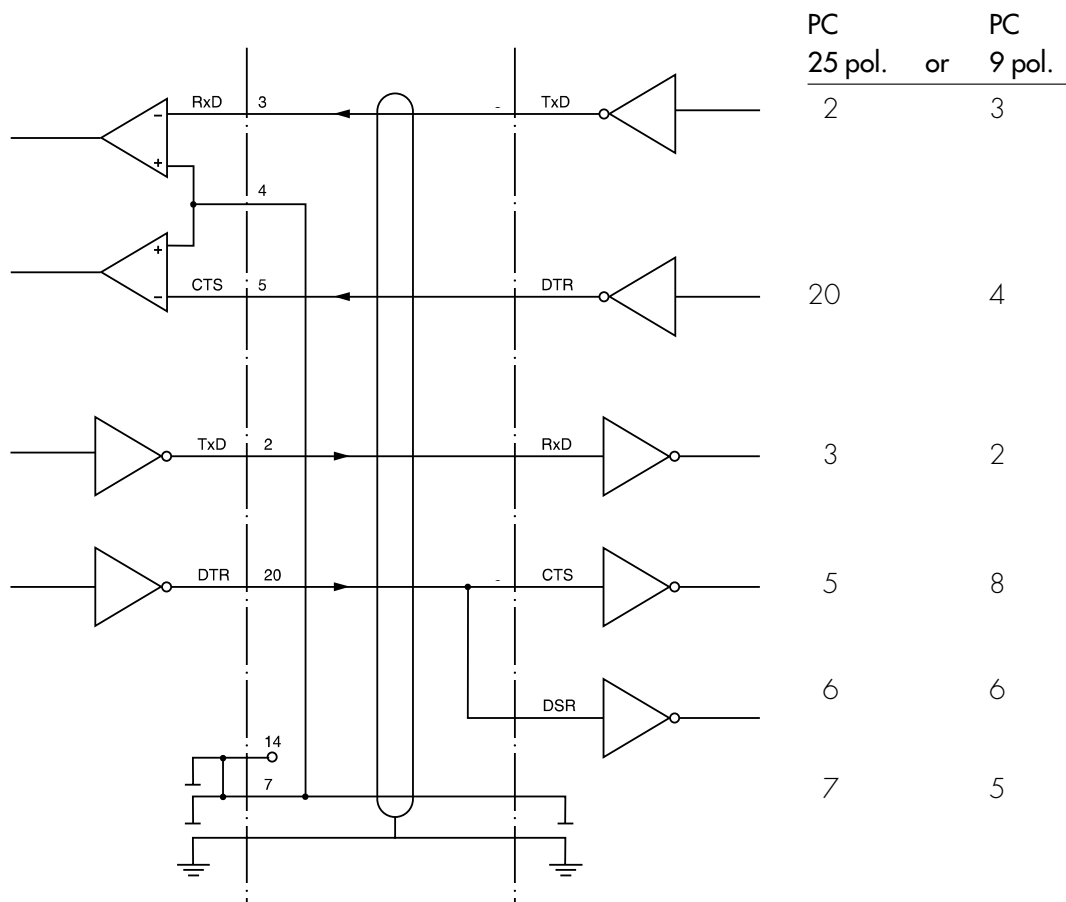
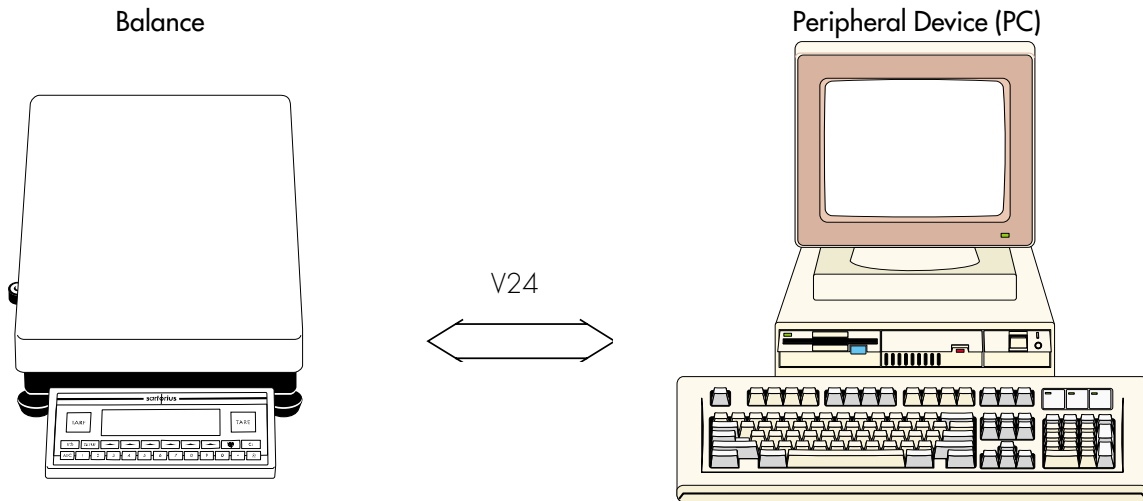

Type of cable: AWG 24 specification

## MP8 Interface Emulation

### Purpose

With the MP8 interface emulation function you can connect peripheral devices of the MP8 generation that have separate AC power supplies (such as the 73822... Data Control terminal, a YFC... Flow Rate Controller, a YDI 50 Z Data Input dedicated keyboard, etc.) to your Master<sup>PRO</sup> balance.

### Available Features

- The balance is only used to determine weights
- The interface communicates exclusively in the MP8 binary protocol.
- You can select application programs for use with the MP8 under item 3 in the balance operating menu.
- You can set the Index 2 program for MP8 can be selected under item 3 of the balance operating menu
- In the application menu, you can only define parameters for the keypad and display.
- The following parameters remain accessible as before:
  - Weighing parameters **[1-x-x]**
  - Extra functions **[8-x-x]**
  - Reset function **[9-x-x]**
 (see "Setup Parameters (Overview)" in the chapter entitled "Configuring the Balance" in the Installation and Operating Instructions)
- MP8 interface emulation is not allowed when you use your balance as a legal measuring instrument (legal for trade). The emulation function is de-activated when the menu access switch is sealed for legal metrology.

### Factory Settings

(for MP8 functions)

MP8 application: **MP8: 3-1-1**

Program index 2: **1 Ind. 2.1**

### Preparation

- Turn on the balance: Press **[I/O]**
- > The Sartorius logo is displayed

Switch to the MP8 interface:

- Press **[SETUP]**
- Select balance operating menu: **Menu** soft key
- Select and confirm the **menu reset function**: **▼** soft key 6 times, then **➤** soft key
- Confirm **factory settings**: **➤** soft key
- Select and confirm **Set to MP8 [9-1-9]**  
**▼** or **▲** soft key, repeatedly if necessary; then **↓** soft key
- Press the **◀◀** soft key

Parameter Settings for the MP8 Interface



- Press **[SETUP]**
- Select the balance operating menu: **Menu** soft key
- Select and confirm:
  - **3 Application: 1 Program selection:**
    - 1 MP8: 3-1-1** or  
...  
**9 MP8: 3-1-9** or  
**10 MP8: 3-2-1** or  
...  
**18 MP8: 3-2-9** or  
**19 MP8: 3-3-1** or  
...  
**27 MP8: 3-3-9**
  - **4 Program index; 2 Ind. 2:**
    - 1 Ind. 2.1** or  
**2 Ind. 2.2** or  
**3 Ind. 2.3** or  
**4 Ind. 2.4**
  - **5 Interface:**
    - 1 Baud rate**
      - 1 150 baud** or  
**2 300 baud** or  
**3 600 baud** or  
**4 1,200 baud** or  
**5 2,400 baud** or  
**6 4,800 baud** or  
**7 9,600 baud** or
    - 2 Parity**
      - 1 Mark** or  
**2 Space** or  
**3 Odd** or  
**4 Even**
  - **6 Print in weighing mode:**
    - 1 Manual/auto print mode**
      - 1 Manual without stability** or  
**2 Manual with stability** or  
**4 Automatic without stability** or  
**5 Automatic at stability**
- Store settings and exit the Setup menu: Press the **◀◀** soft key

## Error Codes and Messages

Error codes and messages are displayed in the main display or text line for 2 seconds.  
The program then returns automatically to the previous status.

Display	Cause	Solution
No segments appear on the display	No AC power is available	Check the AC power supply
	The AC adapter is not plugged in	Plug in the AC adapter
	Automatic shutoff configured in Setup (code <b>B 7 i</b> )	Press <b>[ON]</b> to switch on the balance or select code <b>B 7 2</b> in Setup ("no automatic shutoff")
<b>H</b>	The load exceeds the balance capacity	Unload the balance capacity
<b>L</b> or <b>Err 54</b>	The weighing pan is not in place	Place the weighing pan on the balance
<b>Err 01</b> > Display range	Data output not compatible with output format	Change the configuration in the Setup menu
<b>Err 02</b> Cal. n. possible	Calibration/adjustment condition not met, e.g., – The balance was not tared – The balance is loaded	Calibrate only when zero is displayed Press <b>[TARE]</b> to tare Unload the balance
<b>Err 03</b> Cal./adj. interrupt	Calibration/adjustment could not be completed within a certain time	Allow the balance to warm up again and repeat the adjustment process
<b>Err 06</b> Int. wt. defective	Built-in calibration weight is defective	Contact your local Sartorius Service Center
<b>Err 07</b> Function blocked	Function not allowed in balances verified for use in legal metrology	Contact your local Sartorius Service Center for information on having the settings changed
<b>Err 08*</b> <> zero range	The load on the balance is too heavy to zero the readout	Check whether the "power-on zero range" is set
<b>Err 09*</b> < 0 not allowed	Taring is not possible when the gross weight is $\leq$ zero	Zero the balance
<b>Err 10</b> Tare fct. blocked	Tare key and 2nd tare memory are blocked when there is data in the tare memory for the formulation application Differential weighing: The tare key is blocked when a tare weight is stored for a specific sample	Press <b>[CF]</b> to clear the formulation application; the tare key and 2nd tare memory are then accessible  Differential weighing: Unload the balance or change to a different sample
<b>Err 11</b> Tare2 blocked	Tare memory not allowed – Cannot load the sample tare weight – Total weight in the tare memory exceeds the capacity of the balance – Tare value exceeds the fine range of the verified balance	Check the tare value entered
<b>Err 12</b> Tare2 > Max.	Tare memory greater than weighing range or range limits	Check sample/container
<b>Err 17</b> Adj.-wt. > Max.	Internal adjustment is not possible because preload is too heavy	Reduce the preload or change the configuration
<b>Err 30</b> Print fct. blocked	Interface port for printer output is blocked	Contact your local Sartorius Service Center

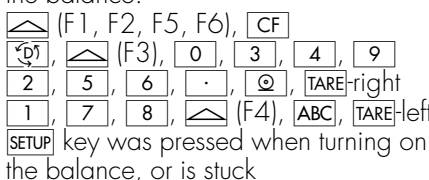
\* = occurs only via the SBI interface (ESC f3\_/f4\_)

Display/Problem	Cause	Solution
<b>Err 31</b> Print fct. blocked	Interface handshake interrupted (XOFF, CTS)	Transmit XON, then CTS
Ref.wt. too light	Error in storing reference weight (with the counting or weighing-in-percent application)	Weight too light or there is no sample on the balance
Cannot update	Reference updating not possible (with the counting application)	See "Counting" in "Operating the Balance" for reference updating criteria
Not a number xxxxx Too low xxxxx Too high	Input wrong (with any application program), e.g., alphabetic input not allowed	Follow the instructions for the application programs
Too many char.	Input text too long	Allowable text lengths, incl. decimal point: – S ID, NUM, L ID, ID: max. 20 characters – W ID: max. 14 characters
Wrong line format	Configured printout, printout memory and 16-character format selected	Select the 22-character format
Limits unequal for unit	Unit entered for tolerance limits in checkweighing different from the appl. used	Adjust tolerance limits
Equation too long	Equation exceeds 28 characters formulation	Limit equation to 28 characters
<b>Err 10x</b>  x = 1 : x = 2 : x = 3 : x = 4 : "Checkerboard" pattern displayed continuously	Key is stuck Key pressed when switching on the balance:  "SETUP" key was pressed when turning on the balance, or is stuck	Release key or Contact your local Sartorius Service Center
<b>Err 320</b>	Operating program memory defective	Contact your local Sartorius Service Center
<b>Err 340</b>	Operating parameter (EEPROM) is wrong RAM lost data Factory settings deleted	Turn the balance off, then back on again. If this error remains displayed, please contact your local Sartorius Service Center
<b>Err 341</b>	Battery needs to be recharged	Leave the balance power on for at least 10 hours
<b>No WP</b>  blocked	Weighing platform is defective  Function blocked	Contact your local Sartorius Service Center  none
The special code  remains displayed	None of the keys has been pressed since the balance was turned on	Press a key
The weight readout changes constantly	Unstable ambient conditions Too much vibration, or the balance is exposed to a draft  A foreign object is caught between the pan and the balance housing	Set up the balance in another area Change Setup configurations to adapt the balance to the ambient conditions  Remove the foreign object
The weight readout is obviously wrong	The balance has not been calibrated/adjusted  The balance was not tared before weighing  The balance is not level  The dust cover is caught under the weighing pan	Calibrate/adjust the balance  Tare before weighing  Level the balance  See "Replacing the Dust Cover" in the chapter "Care and Maintenance"

If any other errors occur, contact your local Sartorius Service Center!

## Care and Maintenance

### Service

Regular servicing by a Sartorius technician will extend the service life of your balance and ensure its continued weighing accuracy. Sartorius can offer you service contracts, with your choice of regular maintenance intervals ranging from 1 month to 2 years.

### Repairs

Repair work must be performed by trained service technicians. Any attempt by untrained persons to perform repairs may lead to hazards for the user.

The replacement backup battery used in the display and control unit (soldered to PCB), type VL2020, is supplied by the manufacturer Panasonic. Only trained service technicians are allowed to replace this battery.

#### Caution:

Danger of explosion if the battery is incorrectly replaced. Replace only with the same or equivalent type recommended by the manufacturer. Dispose of used batteries according to the manufacturer's instructions.

### Cleaning

- ⚠ Make sure that no dust or liquid enters the balance housing
- ⚠ Do not use any aggressive cleaning agents (solvents or similar agents)
- Unplug the AC adapter from the wall outlet (mains supply)
- If you have a data cable connected to the interface, unplug it from the balance
- Carefully remove any sample residue/spilled powder using a brush or a hand-held vacuum cleaner
- Clean the balance using a piece of cloth which has been wet with a mild detergent (soap)
- After cleaning, wipe down the balance with a soft, dry cloth

### Replacing the Dust Cover

- > Instructions for replacing a damaged dust cover

#### For LA Series Balances with a Round Glass Draft Shield

- Remove the following parts from the balance:
  - Draft shield cover
  - Glass draft shield cylinder
  - Weighing pan
  - Pan support
  - Shield disk: turn clockwise and lift off
  - Old dust cover
- Place the new dust cover on the balance and press down on the front and back along the edges until it is seated firmly
- Place the shield disk on the balance and turn it counterclockwise
- Follow the above instructions in reverse order when placing the remaining parts back on the balance.

#### For LA Series Balances with a Rectangular Weighing Pan and a Weighing Capacity $\leq 12$ kg

- Remove the following parts from the balance:
  - Weighing pan
  - Pan draft shield (depending on balance model)
  - Old dust cover
- Place the new dust cover over the balance
- Follow the above instructions in reverse order when placing the remaining parts back on the balance.
- ⚠ The dust cover must not touch the weighing pan

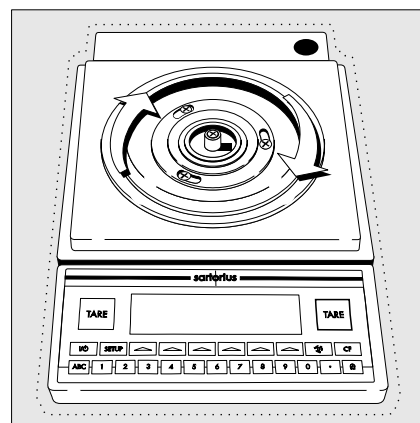

### Safety Inspection

If there is any indication that safe operation of the balance with the AC adapter is no longer warranted:

- Turn off the power and disconnect the equipment from AC power immediately
- > Lock the equipment in a secure place to ensure that it cannot be used during this time

Safe operation of the balance with the AC adapter is no longer ensured when:

- there is visible damage to the AC adapter
- the AC adapter no longer functions properly
- The AC adapter has been stored for a relatively long period under unfavorable conditions

In these cases, notify your nearest Sartorius Service Center or the International Technical Support Unit based in Goettingen, Germany. Maintenance and repair work may only be performed by service technicians who are authorized by Sartorius and who

- have access to the required maintenance manuals
- have attended the relevant service training courses

### Instructions for Recycling the Packaging

To ensure safe shipment, your balance has been packaged using environmentally friendly materials. After successful installation of the balance, you should return this packaging for recycling.

For information on recycling options, including recycling of old weighing equipment and disposal of used batteries contact your municipal waste disposal center or local recycling depot.

# Overview

## General View of the Balances

LA310S (-OCE), LA230S (-OCE), LA230P (-OCE), LA120S (-OCE)

-OCE identifies the precision scales as verified for legal metrology in the EU\*

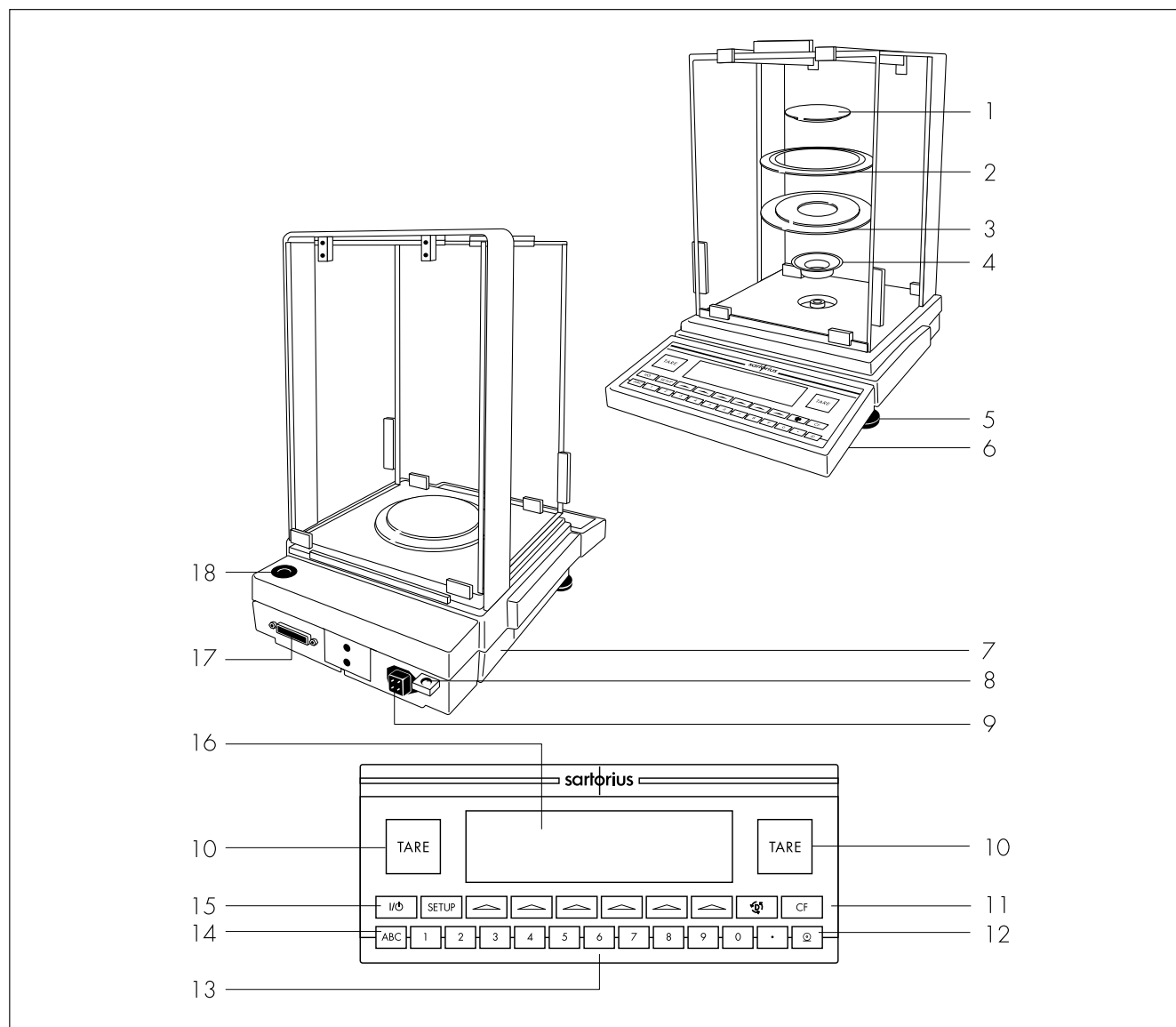

Pos.	Designation	Order No. for replacement	Pos.	Designation	Order No. for replacement
1	Weighing pan	69 LA0006	11	Function keys	
2	Shield disk	69 A20003	12	Print key	
3	Shield plate	69 LA0008	13	Numeric keys	
4	Bushing (pan adapter)	69 LA0007	14	Toggle key for alphabetic input	
5	Leveling foot	69 B20005	15	On/off key	
6	Display and control unit		16	Display	
7	Metrological ID label (only on scales verified for legal metrology)		17	Data interface port	
8	Lug for attaching an anti-theft locking device		18	Level indicator	
9	DC jack		Not shown:		
10	Tare key		Dust cover	69 60LA01	
			Protective caps and plugs (set)	69 B20009	

General Views of the Balances

LA1200S (-OCE), LA620S (-OCE), LA220S (-OCE), LA620P (-OCE), LA3200D

-OCE identifies the precision scales as verified for legal metrology in the EU\*

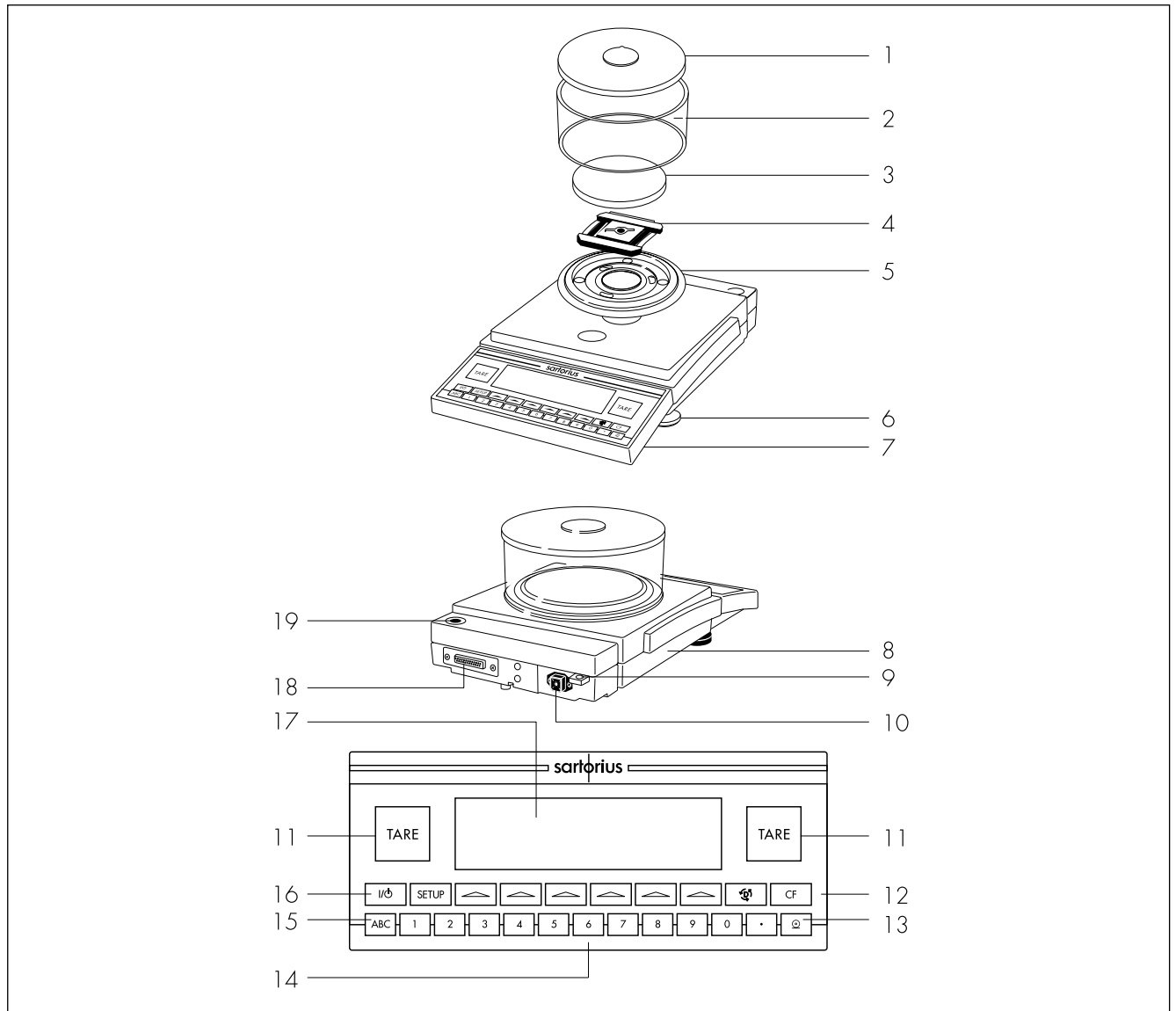

No.	Designation	Order no. for replacement	No.	Designation	Order no. for replacement
1	Draft shield cover	69 LP 0002	11	Tare key	
2	Glass draft shield cylinder	69 14290	12	Function keys	
3	Weighing pan	69 LP 0004	13	Print key	
4	Pan support – LA 3200D: – LA 1200S, LA 620, LA 220S:	69 LP 0006 69 LP 0005	14	Keys for numeric input	
5	Shield disk	69 LP 0003	15	Toggle key for alphabetic input	
6	Leveling foot	69 B20005	16	On/off key	
7	Display and control unit		17	Weight display	
8	Metrological ID label (only on verified models or models acceptable for legal metrological verification)		18	Interface port	
9	Lug for attaching an antitheft locking device		19	Level indicator	
10	DC jack		Not shown:		
			Dust cover		69 60LP 01
			Protective caps and plugs (set)		69 B20009

\* including the Signatories of the Agreement on the European Economic Area

## General Views of the Balances

LA8200S(-OCE), LA8200P(-OCE), LA6200S (-OCE), LA4200S (-OCE), LA2200S (-OCE), LA820 (-OCE), LA420, LA2200P (-OCE), LA5200P (-OCE), LA12000S (-OCE), LA6200 (-OCE), LA4200, LA2200 (-OCE), LA12000P (-OCE)

-OCE identifies the precision scales as verified for legal metrology in the EU\*

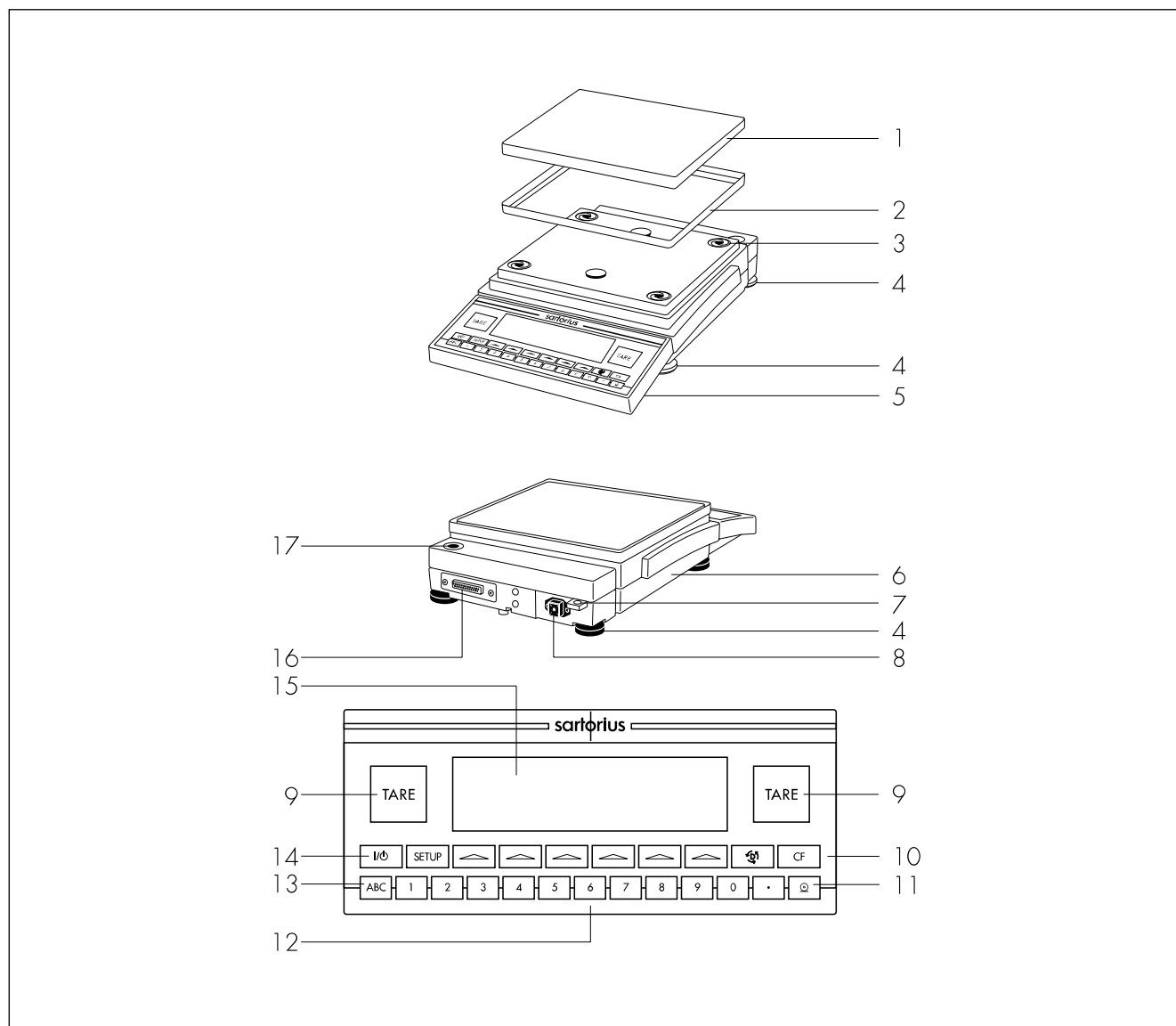

No.	Designation	Order no. for replacement	No.	Designation	Order no. for replacement
1	Weighing pan	69 LP0007	10	Function keys	
2	Pan draft shield (depending on model)	69 LP0008	11	Print key	
3	Shock absorber	69 LP0010	12	Keys for numeric input	
4	Leveling foot	69 B20005	13	Toggle key for alphabetic input	
5	Display and control unit		14	On/off key	
6	Metrological ID label (only on verified models or models acceptable for legal metrological verification)		15	Weight display	
7	Lug for attaching an antitheft locking device		16	Interface port	
8	DC jack		17	Level indicator	
9	Tare key			Not shown:	
				Dust cover	69 60LP02
				Protective caps and plugs (set)	69 B20009

\* including the Signatories of the Agreement on the European Economic Area

### General Views of the Balances

LA64001S, LA34001S, LA16001S, LA34001P, LA34000

-OCE identifies the precision scales as verified for legal metrology in the EU\*

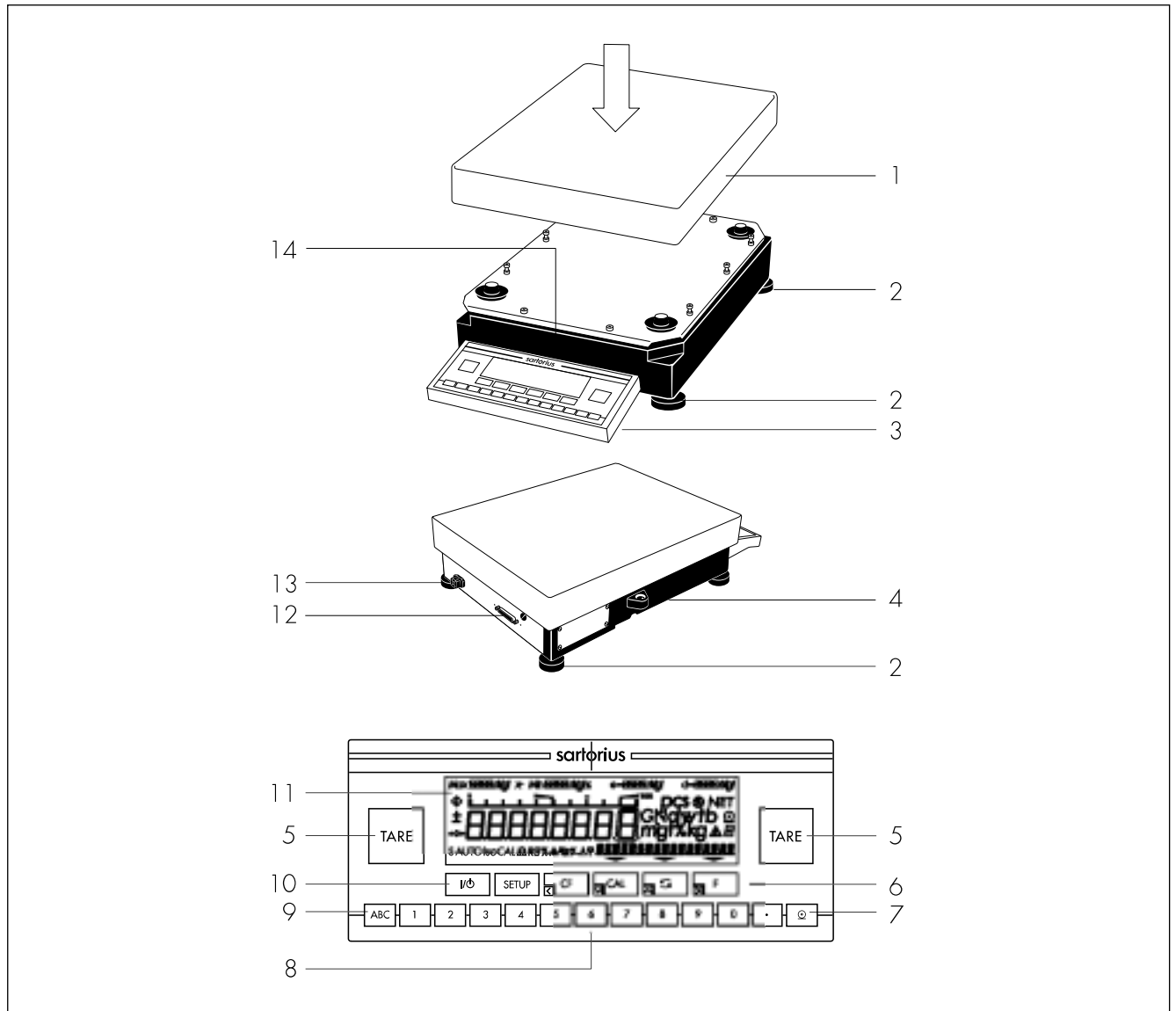

No.	Designation for replacement	Order no.	No.	Designation for replacement	Order no.
1	Weighing pan – LA16000S, LA34000P, LA34001S, LA34001S, LA16001S, LA34001P, LA34000:	69 LC0107 Available on request	8	Keys for numeric input	
2	Leveling foot	69 LC0093	9	Toggle key for alphabetic input	
3	Display and control unit		10	On/off key	
4	Level indicator		11	Weight display	
5	Tare key		12	Interface port	
6	Function keys		13	AC jack	
7	Print key		14	Metrological ID label (only on verified models or models acceptable for legal metrological verification)	
			Not shown:		
			Dust cover for display and control unit	69 60LP03	

\* including the Signatories of the Agreement on the European Economic Area

## Description of the Keys

### Standard Function Keys

 key On/off switch

Switches the display on/off.  
The balance remains in standby mode.

 key Configuring the Balance

- Access to the Setup menu

You can select:

#### **Conf**

You can individually define the number of items to be included on the printout for applications

#### **App**

Application menu with plain English prompts for adapting applications to individual requirements

#### **Info**

Display basic and FlexPrint information about the equipment (e.g., model name, serial no., software version)

#### **Menu**

Balance operating menu with plain English prompts for adapting the scale to individual requirements

#### **Input**

For entering identifying information and device parameters (e.g., balance ID, password)

 key Function Keys (F1–F6)

- Select and start application program functions
- Select and start calibration/adjustment routines
- Navigation within App, Info, Menu and Input parameters in the Setup menu

 key Toggle Application Programs

For toggling the display between applications in the different application groups

 key Clear

This key is generally used to interrupt/cancel functions:

- Delete keyboard input and clear memory
- Interrupt calibration/adjustment routines
- Return application program to previous status

 key Tare

Two large keys for initiating the tare function. Ideally situated for both right-handed and left-handed operation.

Sets the readout to zero. With balances that have the "PolyRange" weighing capacity structure, the fine range is available when this key is pressed.

 key

Press this key to enter alphabetic characters and/or special characters (\*, /, space, etc.).

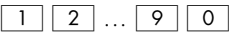
 keys

For numeric input (e.g., ID numbers)

 key

Define the decimal point position (conclude input of digits that come before the decimal point)

 key Data Output

Press this key to output data to via the interface to a Sartorius "DataPrinter" or a computer.

## Specifications

### Standard Models

#### General Specifications

AC power source/power requirements	AC adapter, 230 or 115 V, +15% ... - 20%		
Frequency	48 – 60 Hz		
Allowable ambient operating temperature	0 ... +40 °C (273 ... 313 K, 32 °F ... 104 °F)		
Operating temperature range	+ 10 ... + 30 °C		
Adaptation to ambient conditions	By selection of 1 of 4 optimized filter levels		
Display update (depends on the filter level selected)	0.1 – 0.4		
Power consumption	16 VA: maximum; 9 VA: average		
Hours of operation with fully charged YRB 06 Z external battery pack, approx.	14 h		
Selectable weight units	Grams, kilograms, carats, pounds, ounces, Troy ounces, Hong Kong taels, Singapore taels, Taiwanese taels, grains, pennyweights, milligrams, parts per pound, Chinese taels, Mommies, Austrian carats, Tola, Baht and Mesghal		
Selectable application programs	Mass unit conversion, counting, weighing in percent, animal weighing, recalculation, calculation, density determination, differential weighing, over/under checkweighing, time-controlled functions, totalizing, statistics, 2nd tare memory, IDs, product data memories		
Built-in interface	RS-232C Format: 7-bit ASCII, 1 start bit, 1 or 2 stop bits Parity: odd, even or space Transmission rates: 150 to 19,200 baud Handshake: Software or hardware		

#### Specifications of the Individual Models:

Model		LA310S	LA230S	LA230P	LA120S
Readability	mg	0.1	0.1	0.1/0.2/0.5	0.1
Weighing capacity	g	310	230	60/120/230	120
Tare range (subtractive)	g	- 310	- 230	- 230	- 120
Repeatability	≤±mg	0.2	0.1	0.1/0.2/0.5	0.1
Linearity	≤±mg	0.3	0.2	0.2/0.2/0.5	0.2
Sensitivity drift within +10 ... +30 °C	≤±/K	1 · 10 <sup>-6</sup>			
Response time (average)	s	2			
External calibration weight (of at least accuracy class...)	g	200 + 100 (E2)	200 (E2)	200 (E2)	100 (E2)
Other allowable external calibration weights (of at least accuracy class...)	g	200 (E2)	100, 150 (E2)	100, 150 (E2)	50 (E2)
Pan size	mm	Ø 90			
Dimensions (W x D x H)	mm	240 x 373 x 361			
Clearance above pan	mm	259			
Net weight, approx.	kg	8.7			
Dust and water protection rating according to EN 60529*		IP42			

\* = specially protected dust-tight and washdown resistant AC adapter; see the section on "Accessories"

Model		LA1200S	LA620S	LA220S	LA620P
Readability	g	0.001	0.001	0.001	0.001/0.002/ 0.005
Weighing capacity	g	1,200	620	220	120/240/620
Tare range (subtractive)	g	- 1,200	- 620	- 220	- 620
Repeatability (standard deviation)	≤±g	0.001	0.001	0.001	0.001/0.001 0.003
Linearity	≤±g	0.002	0.002	0.002	0.002/0.002/ 0.005
Sensitivity drift within +10 ... +30 °C	≤±/K	2 · 10 <sup>-6</sup>			
Response time (average)	s	1.5			
External calibration weight (of at least accuracy class...)	g	1,000 (E2)	500 (E2)	200 (E2)	500 (F1)
Other allowable external calibration weights (of at least accuracy class...)	g	-	300, 400, 600 (E2)	100 (E2)	200, 300, 400, 600 (F1)
Pan size	mm	Ø 130			
Dimensions (W x D x H)	mm	240 x 360 x 147			
Net weight, approx.	kg	8.3	6.6	6.6	6.6
Dust and water protection rating according to EN 60529*		IP54			

Model		LA5200D	LA3200D	LA2000P
Readability	g	0.001/0.01	0.001/0.01	0.001/0.01
Weighing capacity	g	1,010/5,200	1,010/3,200	1,010/2,000
Tare range (subtractive)	g	- 5,200	- 3,200	- 2,000
Repeatability	≤±g	0.001/0.01	0.001/0.01	0.001/0.01
Linearity	≤±g	0.002/0.01	0.002/0.01	0.002/0.01
Sensitivity drift within +10 ... +30 °C	≤±/K	2 · 10 <sup>-6</sup>	2 · 10 <sup>-6</sup>	2 · 10 <sup>-6</sup>
Response time (average)	s	2.5	1.5	1.5
External calibration weight (of at least accuracy class...)	g	1,000 (E2)	1,000 (E2)	1,000 (E2)
Other allowable external calibration weights (of at least accuracy class...)	g	2,000, 3,000 (E2)	2,000, 3,000 (E2)	-
Pan size	mm	Ø 130		
Dimensions (W x D x H)	mm	240 x 373 x 147		
Net weight, approx.	kg	8.4		
Dust and water protection rating according to EN 60529*		IP54		

\* = specially protected dust-tight and washdown resistant AC adapter; see the section on "Accessories"

Model		LA8200S	LA8200P	LA6200S	LA4200S	LA2200S
Readability	g	0.01	0.01/0.02/ 0.05	0.01	0.01	0.01
Weighing capacity	g	8,200	2,000/4,000/ 8,200	6,200	4,200	2,200
Tare range (subtractive)	g	- 8,200	- 8,200	- 6,200	- 4,200	- 2,200
Repeatability (standard deviation)	≤±g	0.01	0.01/0.01/ 0.03	0.01	0.01	0.01
Linearity	≤±g	0.02	0.02/0.02/ 0.05	0.02	0.02	0.02
Sensitivity drift within +10 ... +30 °C	≤±/K	2 · 10 <sup>-6</sup>				
Response time (average)	s	2	2	1.5	1.5	1.5
External calibration weight (of at least accuracy class...)	g	5,000 (E2)	5,000 (F1)	5,000 (E2)	2,000 (E2)	2,000 (F1)
Other allowable external calibration weights (of at least accuracy class...)	g	6,000, 7,000, 8,000 (E2)	-	6,000 (E2), 4,000 (E2)	3,000	1,000 (F1)
Pan size	mm	218 x 200				
Dimensions (W x D x H)	mm	240 x 373 x 86				
Net weight, approx.	kg	6.5				
Dust and water protection rating according to EN 60529*		IP54				

Model		LA820	LA420	LA2200P	LA5200P
Readability	g	0.01	0.01	0.01/0.02/ 0.05	0.01/0.02/ 0.05/0.1
Weighing capacity	g	820	420	400/800/ 2,200	1,200/2,400/ 3,800/5,200
Tare range (subtractive)	g	- 820	- 420	- 2,200	- 5,200
Repeatability (standard deviation)	≤±g	0.01	0.01	0.01/0.01/ 0.03	0.01/0.02/ 0.05/0.05
Linearity	≤±g	0.01	0.01	0.02/0.02/ 0.05	0.02/0.02/ 0.05/0.1
Sensitivity drift within +10 ... +30 °C	≤±/K	2 · 10 <sup>-6</sup>			
Response time (average)	s	1.5			
External calibration weight (of at least accuracy class...)	g	500 (F2)	200 (F2)	2,000 (F2)	2,000 (F1)
Other allowable external calibration weights (of at least accuracy class...)	g	600, 700, 800 (F2)	300, 400 (F2)	1,000 (F2)	3,000, 4,000, 5,000 (F1)
Pan size	mm	218 x 200			
Dimensions (W x D x H)	mm	240x373x86			
Net weight, approx.	kg	6.5			
Dust and water protection rating according to EN 60529*		IP54			

\* = specially protected dust-tight and washdown resistant AC adapter; see the section on "Accessories"

Model		LA12000S	LA6200	LA4200	LA2200	LA12000P
Readability	g	0.1	0.1	0.1	0.1	0.1/0.2/0.5
Weighing capacity	g	12,000	6,200	4,200	2,200	3,000/6,000/ 12,000
Tare range (subtractive)	g	- 12,000	- 6,200	- 4,200	- 2,200	-12,000
Repeatability (standard deviation)	≤±g	0.05	0.05	0.05	0.05	0.1/0.1/0.3
Linearity	≤±g	0.2	0.1	0.1	0.1	0.1/0.2/0.5
Sensitivity drift within +10 ... +30 °C	≤±/K	4 · 10 <sup>-6</sup>	4 · 10 <sup>-6</sup>	4 · 10 <sup>-6</sup>	2 · 10 <sup>-6</sup>	4 · 10 <sup>-6</sup>
Response time (average)	s	1	1	1	1	1
External calibration weight (of at least accuracy class...)	kg	5 (F1)	5 (F2)	2 (F2)	2 (F2)	5 (F2)
Other allowable external calibration weights (of at least accuracy class...)	kg	6 to 12 (F1)	4, 6 (F2)	3, 4 (F2)	1 (F2)	6, 7, 8, 9, 10, 11, 12 (F2)
Pan size	mm	218 x 200				
Dimensions (W x D x H)	mm	240x373x86				
Net weight, approx.	kg	6.5				
Dust and water protection rating according to EN 60529*		IP54				

Model		LA16000S	LA34000P	LA34
Readability	g	0.1	0.1/0.2/0.5	1
Weighing capacity	g	16,000	8,000/16,000/ 34,000	34,000
Tare range (subtractive)	g	-16,000	- 34,000	- 34,000
Repeatability (standard deviation)	≤±g	0.1	0.1/0.2/0.5	0.5
Linearity	≤±g	0.2	0.2/0.2/0.5	1
Sensitivity drift within +10 ... +30 °C	≤±/K	3 · 10 <sup>-6</sup>	2 · 10 <sup>-6</sup>	2 · 10 <sup>-6</sup>
Response time (average)	s	1.5	1.5	1
External calibration weight (of at least accuracy class...)	kg	10 (F1)	10 (F2)	10 (F2)
Other allowable external calibration weights (of at least accuracy class...)	kg	11 to 16 (F1)	15, 20, 25, 30 (F2)	15, 20, 25, 30 (F2)
Pan size	mm	307 x 417		
Dimensions (W x D x H)	mm	307x538x121		
Net weight, approx.	kg	13.8		

\* = Specially protected dust-tight and washdown-resistant AC adapter; see the section on "Accessories."

Model		LA64001S	LA34001S	LA16001S	LA34001P	LA34000
Readability	g	0.1	0.1	0.1	0.1/0.2/0.5	1
Weighing capacity	g	64,000	34,000	16,000	8,000/16,000/ 34,000	34,000
Tare range (subtractive)	g	- 64,000	- 34,000	- 16,000	- 34,000	- 34,000
Repeatability	≤±g	0.1	0.1	0.05	0.05/0.05/0.1	0.5
Linearity	≤±g	0.5	0.2	0.2	0.2	0.5
Sensitivity drift within +10 ... +30 °C	≤±/K	3 · 10 <sup>-6</sup>	2 · 10 <sup>-6</sup>	2 · 10 <sup>-6</sup>	2 · 10 <sup>-6</sup>	2 · 10 <sup>-6</sup>
Response time (average)	s	1.5	1.5	1.5	1.5	1
External calibration weight (of at least accuracy class...)	kg	10 (F1)	10 (F1)	10 (F1)	10 (F2)	10 (F2)
Other allowable external calibration weights (of at least accuracy class...)	kg	5, 20, 25, 30 (F1)	15, 20, 25, 30 (F1)	11, 12, 13, 14, 15, 16 (F1)	15, 20, 25, 30 (F2)	15, 20, 25, 30 (F2)
Pan size	mm	300 x 400				
Dimensions (W x D x H)	mm	313x534x120				
Net weight, approx.	kg	16.0				
Dust and water protection rating according to EN 60529*		IP44				

\* = Specially protected dust-tight and washdown-resistant AC adapter; see the section on "Accessories."

## Models Verified by the Manufacturer, with EC Type Approval

### General Specifications

AC power source/power requirements	AC adapter, 230 or 115 V, +15% ... – 20%		
Frequency	48 – 60 Hz		
Adaptation to ambient conditions	By selection of 1 of 4 optimized filter levels		
Power consumption	16 VA: maximum; 9 VA: average		
Hours of operation with fully charged YRB 06 Z external battery pack, approx.	14 h		
Selectable application programs	Mass unit conversion, counting, weighing in percent, animal weighing, recalculation, calculation, density determination, differential weighing, checkweighing, time-controlled functions, totalizing, formulating, statistics, 2nd tare memory, IDs, product data memories		
Built-in interface	RS-232 C		
	Format:	7-bit ASCII, 1 start bit, 1 or 2 stop bits	
	Parity:	odd, even or space	
	Transmission rates:	150 to 19,200 baud	
Handshake:	Software or hardware		

### Specifications of the Individual Models:

Model		LA310S-OCE	LA230S-OCE	LA230P-OCE	LA120S-OCE
Type		isoTEST in conjunction with BC BF			
Accuracy class*		Ⓢ	Ⓢ	Ⓢ	Ⓢ
Scale interval, d*	mg	0.1	0.1	0.1/0.2/0.5	0.1
Maximum weighing capacity, Max. *	g	310	230	60/120/230	120
Verification scale interval, e*	g	0.001			
Minimum capacity, Min. *	g	0.01			
Tare range (subtractive)		≤ 100% of the maximum capacity			
Application range according to CD*	g	0.01 – 310	0.01 – 230	0.01 – 230	0.01 – 120
Response time (average)	s	2			
Allowable operating temperature		273 ... 313 K (0 ... +40 °C, 32 °F ... 104 °F) with isoCAL function			
Selectable weight units		Grams, milligrams			
External calibration weight value (of at least accuracy class...)	g	200 + 100 (E2)	200 (E2)	200 (E2)	100 (E2)
Other permissible external calibration weights (of at least accuracy class...)	g	200 (E2)	100, 150 (E2)	100, 150 (E2)	50 (E2)
Pan size	mm	Ø 90			
Dimensions (W x D x H)	mm	240 x 373 x 361			
Net weight approx.	kg	8.7			
Dust and water protection rating according to EN 60529 1)		IP42			

1) = Specially protected dust-tight and washdown-resistant AC adapter; see the section on "Accessories."

\* CD = Council Directive 90/384/EEC for non-automatic weighing instruments used within the European Economic Area

Model		LA1200S-OCE	LA620S-OCE	LA220S-OCE	LA620P-OCE
Type		isoTEST in conjunction with BD BF			
Accuracy class*		Ⓘ	Ⓜ	Ⓜ	Ⓜ
Scale interval, d*	g	0.001	0.001	0.001	0.001/0.002/ 0.005
Maximum weighing capacity, Max.*	g	1,200	620	220	120/240/620
Verification scale interval, e*	g	0.01	0.01	0.01	0.01
Minimum capacity, Min.*	g	0.1	0.02	0.02	0.02
Tare range (subtractive)		≤ 100% of the max. weighing capacity			
Application range according to CD*	g	0.1 – 1,200	0.02 – 620	0.02 – 220	0.02 – 620
Response time (average)	s	1.5			
Allowable operating temperature range		0 ... +40 °C (273 ... 313 K, 32 °F ... 104 °F) with the isoCAL function <sup>1)</sup>			
Selectable weight units		Grams, kilograms			
External calibration weight value (of at least accuracy class...)	g	1,000 (E2)			
Pan size	mm	Ø 130			
Dimensions (W x D x H)	mm	240 x 373 x 147			
Net weight, approx.	kg	8.3	6.9	6.9	6.9
Dust and water protection rating according to EN 60529 <sup>2)</sup>		IP54			

Model		LA8200S-OCE	LA8200P-OCE	LA6200S-OCE	LA4200S-OCE	LA2200S-OCE
Type		isoTEST in conjunction with BD BF				
Accuracy class*		Ⓜ	Ⓜ	Ⓜ	Ⓜ	Ⓜ
Scale interval, d*	g	0.01	0.01/0.02/ 0.05	0.01	0.01	0.01
Maximum weighing capacity, Max.*	g	8,200	2,000/4,000/ 8,200	6,200	4,200	2,200
Verification scale interval, e*	g	0.1	0.1	0.1	0.1	0.1
Minimum capacity, Min.*	g	0.5	0.5	0.5	0.5	0.5
Tare range (subtractive)		≤ 100% of the max. weighing capacity				
Application range according to CD*	g	0.5 – 8,200	0.5 – 8,200	0.5 – 6,200	0.5 – 4,200	0.5 – 2,200
Response time (average)	s	2	2	1.5	1.5	1.5
Allowable operating temperature range		0 ... +40 °C (273 ... 313 K, 32 °F ... 104 °F) with the isoCAL function <sup>1)</sup>				
Selectable weight units		Grams, kilograms				
Pan size	mm	218 x 200				
Dimensions (W x D x H)	mm	240 x 373 x 86				
Net weight, approx.	kg	6.5				
Dust and water protection rating according to EN 60529 <sup>2)</sup>		IP54				

<sup>1)</sup> = With the isoCAL function deactivated, the verified balance can only be used within the limited temperature range (can only be modified by the Sartorius Service Center): For balances of accuracy class Ⓘ: +15°C to +25°C (+59°F to +77°F)  
For balances of accuracy class Ⓜ: +10°C to +30°C (+50°F to +86°F)

<sup>2)</sup> = Specially protected dust-tight and washdown-resistant AC adapter; see the section on "Accessories."

\* CD = Council Directive 90/384/EEC for non-automatic weighing instruments used within the European Economic Area

Model	LA820-OCE	LA2200P-OCE	LA5200P-OCE	LA12000S-OCE	LA6200-OCE
Type	isoTEST in conjunction with BD BF				
Accuracy class*	Ⓔ				
Scale interval, d*	g 0.01	0.01/0.02/ 0.05	0.01/0.02/ 0.05/0.1	0.1	0.1
Maximum weighing capacity, Max.*	g 820	400/800/ 2,200	1,200/2,400/ 3,800/5,200	12,000	6,200
Verification scale interval, e*	g 0.1	0.1	0.1	1	1
Minimum capacity, Min.*	g 0.5	0.5	0.5	5	5
Tare range (subtractive)	≤ 100% of the max. weighing capacity				
Application range according to CD*	g 0.5 – 820	0.5 – 2,200	0.5 – 5,200	5 – 12,000	5 – 6,200
Response time (average)	s 1.5	1.5	1.5	1	1
Allowable operating temperature range	0 ... +40 °C (273 ... 313 K, 32 °F ... 104 °F) with the isoCAL function <sup>1)</sup>				
Selectable weight units	Grams, kilograms				
Pan size	mm 218 x 200				
Dimensions (W x D x H)	mm 240 x 373x 86				
Net weight, approx.	kg 6.5				
Dust and water protection rating according to EN 60529 <sup>2)</sup>	IP54				

Model	LA2200-OCE	LA12000P-OCE	LA16000S-OCE	LA34000P-OCE	LA34-OCE
Type	isoTEST in conjunction with BD BF				
Accuracy class*	Ⓔ				
Scale interval, d*	g 0.1	0.1/0.2/0.5	0.1	0.1/0.2/0.5	1
Maximum weighing capacity, Max.*	g 2,200	3,000/6,000/ 12,000	16,000	8,000/16,000/ 34,000	34,000
Verification scale interval, e*	g 0.1	1	1	1	1
Minimum capacity, Min.*	g 5	5	5	5	50
Tare range (subtractive)	≤ 100% of the max. weighing capacity				
Application range according to CD*	g 5 – 2,200	5 – 12,000	5 – 16,000	5 – 34,000	50 – 34,000
Response time (average)	s 1	1	1.5	1.5	1
Allowable operating temperature range	0 ... +40 °C (273 ... 313 K, 32 °F ... 104 °F) with the isoCAL function <sup>1)</sup>		+10 ... +30 °C (+50°F to +86°F)		
Selectable weight units	Grams, kilograms	Grams, kilograms	Grams, kilograms	Grams, kilograms	Kilograms
Pan size	mm 218 x 200	218 x 200	307 x 417	307 x 417	307 x 417
Dimensions (W x D x H)	mm 240 x 373 x 86	240 x 373 x 86	307x538x121	307x538x121	307x538x121
Net weight, approx.	kg 6.5	6.5	13.8	13.8	13.8

<sup>1)</sup> = With the isoCAL function deactivated, the verified balance can only be used within the limited temperature range (can only be modified by the Sartorius Service Center): For balances of accuracy class Ⓔ: +15°C to +25°C (+59°F to +77°F)  
For balances of accuracy class Ⓔ: +10°C to +30°C (+50°F to +86°F)

<sup>2)</sup> = Specially protected dust-tight and washdown-resistant AC adapter; see the section on "Accessories."

\* CD = Council Directive 90/384/EEC for non-automatic weighing instruments used within the European Economic Area

Model	LA34001S-OCE	LA16001S-OCE	LA34001P-OCE	LA34000-OCE
Type	isoTEST in conjunction with BF BF			
Accuracy class*	Ⓜ	Ⓜ	Ⓜ	Ⓜ
Scale interval, d*	g 0.1	0.1	0.1/0.2/0.5	1
Maximum weighing capacity, Max.*	kg 34	16	8/16/34	34
Verification scale interval, e*	g 1	1	1	1
Minimum capacity, Min.*	g 5	5	5	50
Tare range (subtractive)	≤ 100% of the max. weighing capacity			
Application range acc. to CD*	g 5 – 34,000	5 – 16,000	5 – 34,000	50 – 34,000
Response time (average)	s 1,5	1,5	1,5	1
Allowable operating temperature range	0 ... +40 °C (273 ... 313 K, 32 °F ... 104 °F) with the isoCAL function 1)			
Selectable weight units	Grams and kilograms	Grams and kilograms	Grams and kilograms	Kilograms and grams
Pan size	mm 300 x 400			
Dimensions (W x D x H)	mm 313x534x120			
Net weight, approx.	kg 16.0			
Dust and water protection rating According to EN 60529 2)	IP44			

1) = With the isoCAL function deactivated, the verified balances can be used within the limited temperature range (can only be modified by the Sartorius Service Center): For balances of accuracy class Ⓜ: +15°C to +25°C (+59°F to 77°F)  
For balances of accuracy class Ⓜ: +10°C to +30°C (+50°F to 86°F)

2) = Specially protected dust-tight and washdown-resistant AC adapter; see the section on "Accessories"

\* CD = Council Directive 90/384/EWG for non-automatic weighing instruments used within the European Economic Area

## Accessories

### Product

Order No.

#### Data Printer

YDP03-OCE

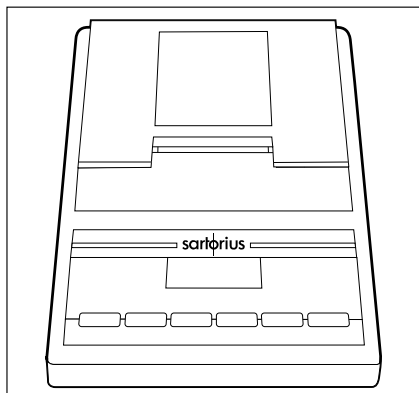

- > with date/time, statistics and transaction counter functions and LCD
- > can be used in legal metrology

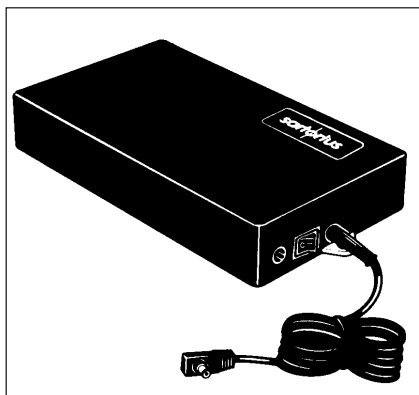

#### External rechargeable battery pack

YRB06Z

- > has a battery-level indicator (LED); can be recharged using the AC adapter (time it takes to charge the discharged battery pack: 15 hours); see "Specifications" for hours of operation
- > can be used in legal metrology

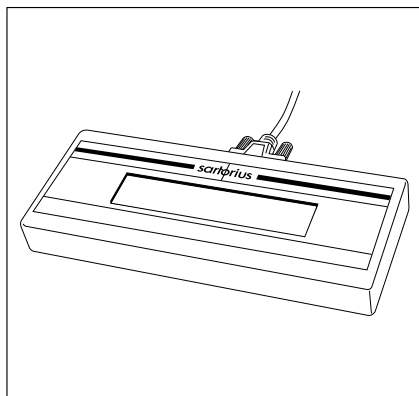

#### Additional remote display (weight readout only)

- > can be connected via the interface port
- LCD, reflective
- LCD for overhead projectors, transmissive
- > can be used in legal metrology

YRD02Z

YRD13Z

#### 3-segment checkweighing display

YRD11Z

- > conveniently shows whether a sample (amount filled) is within the tolerance limits
- > can be used in legal metrology

#### Analytical draft shield chamber

YDS01LP

for the LA2000P, LA1200S, LA 3200D, LA 620S, LA 620P and LA 220S

#### Density determination set

- > for LA310S, LA230S, LA230P and LA120S (-OCE)
- > for LA2000P, LA1200S, LA3200D, LA620S, LA620P and LA220S

YDK01(-OD)

YDK01LP

#### Calibration weights

Information on request

for all LA balances; extensive assortment, available with certification

Product	Order No.
<b>SartoConnect</b> data transfer program for interfacing a Sartorius balance to a PC with a Windows 95/98 or NT operating system This software enables you to transfer the data recorded by your balance to any PC application program (e.g., Excel).	YSC01L
<b>Standard operating instructions</b> for optimal use of your balance in quality management systems	YSL01E
<b>AC adapter ING-2</b> with IP65 protection rating  for 230 V for 120 V	69 71899 69 71500
<b>Antistatic pan</b> for models with a readability of 0.1 mg	YWP01LA
<b>Hook for below-balance weighing</b> for models LA34001S, LA16001S, LA34001P, LA3400	69EA0040
<b>Universal remote control switch</b> for remote control of one of the following functions (configured in the balance Setup): [⊖], [TARE], [CF], Cal soft key, F1 and F2	YFS01
<b>Foot switch with T-connector</b>	YHS02
<b>Hand switch with T-connector</b>	YTC01
<b>Connecting cable to connect the weighing cell to a separate display/control unit (length: 2.70 m)</b> > for balances with a weighing capacity of $\leq 12$ kg > for balances with a weighing capacity of $\geq 16$ kg	YCC01-19M3 Information on request
<b>Support arm (for raised display configuration)</b> > for balances with a weighing capacity $\leq 12$ kg > for balances with a weighing capacity $\geq 16$ kg	YDH01LP YDH02LP
<b>Balance tables</b> > with stone slab insert > made of cast stone	YWT01 YWT03
<b>Carrying case</b> > for balances with a weighing capacity $\leq 12$ kg	YDB01LP

## Declarations of Conformity

### The CE Mark on Sartorius Equipment

In 1985, the Council of the European Community approved a resolution concerning a new approach to the technical harmonization and standardization of national regulations. The organization for monitoring compliance with the directives and standards concerning the CE marking is governed in the individual EU Member States through the implementation of the EC Directives adopted by the respective national laws. As of December 1993, the scope of validity for all EC Directives has been extended to the Member States of the European Union and the Signatories of the Agreement on the European Economic Area.

Sartorius complies with the EC Directives and European Standards in order to supply its customers with weighing instruments that feature the latest advanced technology and provide many years of trouble-free service.

The CE mark may be affixed only to weighing instruments and associated equipment that comply with the applicable Directive(s):

#### **Council Directive 89/336/EEC "Electromagnetic Compatibility (EMC)"**

Acceptable European Standards:

Limitation of emissions:

EN 50081-1

Residential, commercial and light industry

EN 50081-2

Industrial environment

Defined immunity to interference:

EN 50082-1

Residential, commercial and light industry

EN 50082-2

Industrial environment

Important Note:

The operator shall be responsible for any modifications to Sartorius equipment and for any connections of cables or equipment not supplied by Sartorius and must check and, if necessary, correct these modifications and connections. On request, Sartorius will provide information on the minimum operating specifications (in accordance with the Standards listed above for defined immunity to interference).

#### **Council Directive 73/23/EEC "Electrical Equipment Designed for Use within Certain Voltage Limits"**

Applicable European Standards:

EN 60950

Safety of information technology equipment including electrical business equipment

EN 61010

Safety requirements for electrical equipment for measurement, control and laboratory use

Part 1: General requirements

If you use electrical equipment in installations and under ambient conditions requiring higher safety standards, you must comply with the provisions as specified in the applicable regulations for installation in your country.

### **Weighing Instruments for Use in Legal Metrology: Directive 90/384/EEC "Non- automatic Weighing Instruments"**

This Directive regulates the determination of mass in legal metrology.

For the respective Declaration of Conformity for weighing instruments that have been verified by Sartorius for use as legal measuring instruments and that have an EC Type-Approval Certificate, see the page after next.

This Directive also regulates the performance of the EC verification by the manufacturer, provided that an EC Type-Approval Certificate has been issued and the manufacturer has been accredited by an officer or a Notified Body registered at the Commission of the European Community for performing such verification.

The legal basis allowing Sartorius to perform EC verification is constituted by the EC Council Directive No. 90/384/EEC on non-automatic weighing instruments that has been in effect since January 1, 1993, in the Internal Market as well as by the Certificate of Accreditation of the Sartorius AG Quality Management System issued by the Metrology Department of the Regional Administration Office of Lower Saxony, Germany ("Niedersächsisches Landesverwaltungsamt -Eichwesen") on February 15, 1993.

For information on the CE mark on Sartorius equipment and legal regulations currently applicable in your country, and to obtain the names of the persons to contact, please ask your local Sartorius office, dealer or service center.

### **“New Installation” Service**

Initial verification is covered in our “New Installation” service package. In addition to initial verification, this package provides you with a series of important services which will guarantee that you achieve optimal results with your weighing instrument:

- Installation
- Startup
- Inspection
- Training
- Initial verification

If you would like Sartorius to perform initial verification of your weighing instrument, contact an authorized service representative.

### **“EC Verification” – A Service Offered by Sartorius**

Our service technicians are authorized to perform verification\* of your weighing instruments that are acceptable for legal metrological verification and can inspect and verify the metrological specifications at the place of installation within the Member States of the European Union and the Signatories of the Agreement on the European Economic Area.

### **Subsequent Verifications within the European Countries**

The expiration date of the verification depends on the national regulations of the country in which the weighing instrument is used. For information on verification and legal regulations currently applicable in your country, and to obtain the names of the persons to contact, please contact your local Sartorius office, dealer or service center.

\* in accordance with the accreditation certificate issued to Sartorius AG



# Declaration of Type Conformity to Directive No. 90/384/EEC

This declaration is valid for non-automatic electromechanical weighing instruments for use in legal metrology. These weighing instruments accepted for legal metrological verification have an EC Type-Approval Certificate. The model(s) concerned is(are) listed below along with the respective type, accuracy class, and number of the EC Type-Approval Certificate:

Model	Type	Accuracy Class	EC Type Approval No.	In Conjunction with Test Certificate	
				Type	Certificate No.
LA/LP...-OCE	iso-TEST	II or III	D97-09-018	BA BF	D09-96.30
LA/LP...-OCE	iso-TEST	II or III	D97-09-018	BB BD	D09-95.08
LA/LP...-OCE	iso-TEST	I	D97-09-018	BC BF	D09-96.30
LA/LP...-OCE	iso-TEST	I, II or III	D97-09-018	BD BF	D09-96.30
LA/LP...-OCE	iso-TEST	II	D97-09-018	BF BF	D09-96.30

SARTORIUS AG declares that its weighing instrument types comply with the requirements of the Council Directive on non-automatic weighing instruments, no. 90/384/EEC of 20 June 1990; the associated European Standard "Metrological aspects of non-automatic weighing instruments," No. EN 45501; the amended, currently valid versions of the national laws and decrees concerning legal metrology and verification in the Member States of the European Union, the EU, and the Signatories of the Agreement on the European Economic Area, which have adopted this Council Directive into their national laws; and with the requirements stipulated on the Type-Approval Certificate for verification. This Declaration of Type Conformity is valid only if the ID label on the weighing instrument has the CE mark of conformity and the green metrology

sticker with the stamped letter "M" (the two-digit number in large print stands for the year in which the mark has been affixed):



If these marks are not on the ID label, this Declaration of Type Conformity is not valid. Validity can be obtained, for example, by submitting the weighing instrument for final action to be taken by an authorized representative of SARTORIUS AG. The period of validity of this Declaration of Type Conformity shall expire upon any tampering with, repair or modification of this weighing instrument or, in some Member States, on the date of expiration. The operator of this weighing instrument shall be responsible for obtaining an authorized renewal of the verification, such as subsequent or periodic verification, of the weighing instrument for use as a legal measuring instrument.

Sartorius AG  
37070 Goettingen, Germany  
Signed in Göttingen, 17.10.2001

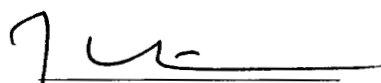
  
M. Warter  
(Executive Board)

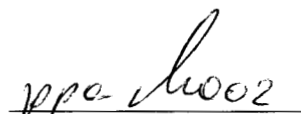
  
Dr. G. Maaz  
(Head of Technical Operations)

OAW-113-2/02.96  
P106eb00.doc

# Physikalisch-Technische Bundesanstalt

Braunschweig und Berlin



## EG-Bauartzulassung

*EC type-approval certificate*

Zulassungsinhaber:

*Issued to:*

Sartorius AG  
Weender Landstraße 94-108  
37075 Göttingen  
Bundesrepublik Deutschland

Rechtsbezug:

*In accordance with:*

§ 13 des Gesetzes über das Meß- und Eichwesen (*verification act*) vom/dated 23. März 1992 (BGBl. I S. 711) in Verbindung mit Richtlinie (*in connection with council directive*) 90/384/EWG, geändert durch (*amended by*) 93/68/EWG

Bauart:

*In respect of:*

Nichtselbsttätige elektromechanische Waage  
*Nonautomatic electromechanical weighing instrument*  
Typ/type: iso-TEST  
Genauigkeitsklasse/class **I**, **II**, **III**, **III** Max 0,05 kg ... 300 t  
Option: Mehrteilungswaage, Mehrbereichswaage  
*Multi-interval instrument, multiple range instrument*

Zulassungsnummer:

*Approval number:*

**D97-09-018 2. Revision**

Gültig bis:

*Valid until:*

26.06.2007

Anzahl der Seiten:

*Number of pages:*

11

Geschäftszeichen:

*Reference No.:*

1.14 – 00035920

Benannte Stelle:

*Notified Body:*

0102

Im Auftrag

*By order*

Link



Braunschweig, 24.07.2000

Siegel

*Seal*

**Physikalisch-Technische Bundesanstalt**

Braunschweig und Berlin

**Prüfschein***Test certificate*

**Ausgestellt für:** Sartorius AG  
*Issued to:* Weender Landstraße 94 – 108  
37075 Göttingen  
Bundesrepublik Deutschland

**Prüfgrundlage:** EN 45501 (1992), Nr.8.1, OIML R 76-1 (1992)  
*In accordance with:*

**Gegenstand:** Lastaufnehmer mit Wägezelle und Auswerteelektronik mit digitalem  
*Object:* geeignete Anzeige- und Bedienterminals  
*Load receptor with load cell and electronic device with digital output as module of an electromechanical weighing instrument for connection to suitable display- and operator-terminals*  
Typ / type **BA BF, BC BF, BD BF, BF BF, MA BF und MD BF**

**Kennnummer:** ---  
*Serial number:*

**Prüfscheinnummer:** D09-96.30 4. Revision / Revision 4  
*Test certificate number:*

**Datum der Prüfung:**  
*Date of Test:*

**Anzahl der Seiten:** 10  
*Number of pages:*

**Geschäftszeichen:** 1.14 – 01052687  
*Reference No.:*

**Benannte Stelle:** 0102  
*Notified Body:*

**Im Auftrag**  
*By order*

Link



Braunschweig, 2001-10-09

**Siegel**  
*Seal*

**Physikalisch-Technische Bundesanstalt**

Braunschweig und Berlin



**Test Certificate**

**N° D09-95.08 Revision 1**

Testing of a  
**Weighing platform with electronic evaluation unit  
of type BB BD**

*issued by:* Physikalisch-Technische Bundesanstalt

*issued to:* Sartorius AG  
Weender Landstraße 94-108  
D-37075 Göttingen  
Federal Republic of Germany

*in accordance with:* EN 45501 (1992)  
(This standard essentially corresponds to OIML Recommendation  
R 76-1, 1992 Edition)

*Object tested:* Weighing platform with load cell and electronic device with digital output  
as module of an electromechanical weighing instrument for connection  
to suitable display and operator terminals

*Manufacturer:* Sartorius AG, Göttingen

The essential functions and characteristics of this module, the conditions to be observed and the specification of the relevant documentation are set out in the Appendix hereto. The module meets the requirements of EN 45501, as far as applicable; it may be used for purposes subject to legal control as module of an electromechanical weighing instrument provided that the conditions stated in EN 45501 and in the Appendix hereto are observed.

The Appendix is an integral part of this Test Certificate and comprises 5 pages.

This Revision 1 replaces Test Certificate D09-95.08 dated 15.03.1995, Reference N° 1.13-5.070.

		<i>By order</i>
<i>Braunschweig,</i>	14.07.1995	
<i>Reference No:</i>	1.13-95.180	<i>(Brandes)</i>
		<i>Seal</i>
Physikalisch-Technische Bundesanstalt Bundesallee 100 D 38116 Braunschweig Federal Republic of Germany		L.S.

*Further information and legal remedy instructions see over-leaf. Test certificates are valid only with signature and seal. This test certificate shall be reproduced only in full. Partial reproduction or modification only upon permission of the Physikalisch-Technische Bundesanstalt.*

This is to certify that the above translation from the German language has been made at the Physikalisch-Technische Bundesanstalt. The original has been produced.

  
(G. Panagiotidis)  
Foreign Languages Department



Braunschweig, May 28, 1998

Z.14-755 320 34-10.93



Index

	Page		Page
Accessories (options)	154	Keypad	108
Acoustic signal	111	Language setting	12
Additional functions (balance menu)	111	Leveling the balance	11
Animal weighing	57	Line format	129
Anti-theft device	11	Manual storage – M+	104
Application filter	30	Manual/automatic print mode	125
Application programs	48	Menu – reset factory settings	112
Applications menu	17	Menu parameters – read only	111
Applications, combining	113	Metrological data, in display	120
Applications, configuring	17	MP8 interface emulation	135
Auto print functions	125	Operating design	3
Auto start application with power-on	108	Operating the balance	37
Auto zero	28	Options	154
Balance menu	28	Overview of Application menu	20
Balance, automatic shutoff	111	Parameter settings	16
Balance, installation	8	Parameters in menu – read only	111
Balance-specific information	12	Password, enter/change	13
Barcode scanner	112	Password, general	Appendix
Bar graph	120	Pin assignment chart	133
Basic settings	108	Plates and Markings	162
Basic weighing functions	32	Power-on mode	111
Below-balance weighing	32	Practical use	2
Block printout	127	Preset tare (2nd tare memory)	98
Cabling diagram	134	Print application parameters	129
Calculation	57	Print manually/automatically	129
Calibration/adjustment	40	Printout	128
Calibration/adjustment, automatic	46	Printout configuration	33, 108
Care and maintenance	138	Printout, animal weighing	125
Checkweighing	78	Printout, calculation	125
Cleaning the balance	138	Printout, time-controlled functions	125
Combining applications	113	Printout, totalizing, formulation, statistics	125
Configuring applications	17	Product data memory	105
Configuring the balance	12	Recalculation	61
Configuring printout	33	Recycling instructions	139
Connecting to AC power	10	Reference sample updating	51
Contents	2	Remote display	4
Contrast, display	13	Repairs	138
Control port	79	Replacing the dust cover	138
Counting	50	Reproducibility test (reproTEST)	47
Data output functions	120	Reset factory settings – menu	112
Data ID codes	130	Safety inspection	138
Data input format	131	Safety precautions	3, 10
Data interface port	128	Second tare memory (preset tare)	98
Data output format	129	Service	138
Data output, following print command	132	Software handshake	132
Data output, initialize	132	Specifications	145
Declaration of conformity	156	Statistics	94
Density determination	69	Storage and shipping conditions	7
Display	4, 108, 120	Symbols in display	120
Display backlighting	111	Synchronization	132
Display, remote	4	Time-controlled functions	83
Dustcover, replacing	138	Toggling between weight units	48
EC type approval certificate	159	Totalizing	86
Emulation MP8 interface	135	Universal remote control switch	111
Enter/change password	13	Unpacking the balance	7
Equipment supplied	7	User data, input	13
Error codes and messages	131	User password	Appendix
External calibration	44	Warmup time	10
Extra functions (application menu)	98	Warnings and safety precautions	3
Factory settings	20	Warranty	7
FlexPrint	109	Weighing in percent	53
Formulation	90	Weighing series number	13
General view of balances	140	Weight set number	13
Handshake mode	132	Workstation number	13
Identifiers	100		
Input	11		
Installation	7		
Interface port	128		
Interface port, input/output	112		
Internal calibration	44		
ISO/GLP printout/record	112, 126		
isoCAL function	46		

# Appendix

## Entering the User Password

### Enter/Change Password

- Select the Setup menu: Press **SETUP**
- > **SETUP SELECTION** is displayed
- Select the user input function: Press the **Input** soft key
- > The password prompt is displayed:

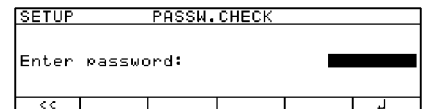

- Enter the User Password (see below)
- Confirm password: Press the **↓** soft key
- > User data is displayed
- Select the password setting function: Press the **↵** soft key repeatedly until
- > **Enter password:** is displayed, together with the current password setting
- Define a new password: Enter letters/numbers for the new password (8 characters max.)  
To delete the current password: press **·** and confirm
- To confirm the new password: press the **↓** soft key
- Exit the Setup menu: Press the **◀◀** soft key
- > Restart your application

User Password: 40414243

## Sartorius AG

✉ 37070 Goettingen, Germany

🏠 Weender Landstrasse 94–108, 37075 Goettingen, Germany

☎ (+49/551) 308-0, 📠 (+49/551) 308-3289

Internet: <http://www.sartorius.com>

Copyright by Sartorius AG, Goettingen, Germany.  
All rights reserved. No part of this publication  
may be reprinted or translated in any form or by any means  
without the prior written permission of Sartorius AG.

The status of the information, specifications and  
illustrations in this manual is indicated by the date  
given below. Sartorius AG reserves the right to  
make changes to the technology, features,  
specifications, and design of the equipment  
without notice.

Status: June 2002, Sartorius AG, Goettingen, Germany

Printed in Germany on paper that has been bleached without any use of chlorine · W1A000 · KT  
Publication No.: W1A6004-e02068

---

The Sartorius logo consists of the word "sartorius" in a bold, lowercase, sans-serif font. A vertical line passes through the center of the letter 'o', which is highlighted with a yellow circle.