



SERVICE GUIDE

M3/M4 Monitors
(M3046A)
Measurement Server
(M3001A and M3000A)
Measurement Server Extensions
(M3015A and M3016A)

PATIENT MONITORING

Printed in Germany 03/05
Sixth Edition



Part Number M3046-9300F
4512 610 07711



**M3046A M2/M3/M4 Monitors
M3000A/M3001A Measurement
Servers
M3015A/M3016A Extensions to the
Measurement Servers**

Service Guide

M3046-9300F
Reordering Number: 4512 610 07711
Printed in Germany. March 2005
Seventh Edition

Notice

This document contains proprietary information which is protected by copyright. All Rights Reserved. Reproduction, adaptation, or translation without prior written permission is prohibited, except as allowed under the copyright laws.

Philips Medizin Systeme Böblingen GmbH
Cardiac and Monitoring Systems
Hewlett-Packard Str. 2
71034 Böblingen
Germany

Printed in Germany

Warranty

The information contained in this document is subject to change without notice.

Philips Medical Systems makes no warranty of any kind with regard to this material, including, but not limited to, the implied warranties or merchantability and fitness for a particular purpose.

Philips Medical Systems shall not be liable for errors contained herein or for incidental or consequential damages in connection with the furnishing, performance, or use of this material.

© 1995-2005 Koninklijke Philips Electronics N.V.

All Rights Reserved. Reproduction in whole or in part is prohibited without the prior written consent of the copyright holder.

Philips Electronics North America Corporation reserves the right to make changes in specifications or to discontinue any product at any time without notice or obligation and will not be liable for any consequences resulting from the use of this publication.

Microsoft, Windows NT and Windows 2000 are trademarks of Microsoft Corporation in the USA and other countries.

Printing History

New editions of this document will incorporate all material updated since the previous edition. Update packages may be issued between editions and contain replacement and additional pages to be merged by a revision date at the bottom of the page. Note that pages which are rearranged due to changes on a previous page are not considered revised.

The documentation printing date and part number indicate its current edition. The printing date changes when a new edition is printed. (Minor corrections and updates which are incorporated at reprint do not cause the date to change.) The document part number changes when extensive technical changes are incorporated.

First Edition July 1997

Second Edition February 1999

Third Edition June 2000

Fourth Edition April 2001

Fifth Edition February 2002

Sixth Edition June 2003

Seventh Edition March 2005

Responsibility of the Manufacturer

Philips Medical Systems only considers itself responsible for any effects on safety, reliability and performance of the equipment if:

- assembly operations, extensions, re-adjustments, modifications or repairs are carried out by persons authorized by Philips, and
- the electrical installation of the relevant room complies with national standards, and
- the instrument is used in accordance with the instructions for use.

To ensure safety, use only those Philips parts and accessories specified for use with the Monitor. If non-Philips parts are used, Philips Medical Systems is not liable for any damage that these parts may cause to the equipment.

In this Book

This Service Guide contains technical details on the Monitor, Measurement Server and Measurement Server Extensions.

The purpose of this book is to provide a technical foundation for the monitoring system in order to support effective troubleshooting and repair. The book is not intended to be a comprehensive, in-depth explanation of the product architecture or technical implementation. Rather, it is developed to offer enough information on the functions and operations of the monitoring systems so that engineers who repair them are better able to understand how they work.

It covers the physiological measurements that the products are designed to provide, the Measurement Server that acquires those measurements, and the monitoring system that displays them.

Who Should Use this Book

If you are a biomedical engineer or a technician responsible for troubleshooting, repairing, and maintaining Philips's patient monitoring systems, this book is designed for you. If you are new to Philips's product line or monitoring systems, you may find this book helpful as an orientation to the equipment. If you have already worked on the systems and now want further details on how they work, you are likely to find much of the information you need here.

Conventions Used in this Book

WARNING

A warning alerts you to a potential serious outcome, adverse event or safety hazard. Failure to observe a warning may result in death or serious injury to the user or patient.

CAUTION

A caution alerts you to circumstances where special care is necessary for the safe and effective use of the product. Failure to observe a caution may result in minor or moderate personal injury, damage to the product or other property, and possibly in a remote risk of more serious injury.

Contents

1 Introduction to the Instrument.	1
Objectives.	1
Concepts.	1
Introducing the Instrument Components	2
Instrument Components	4
A Quick Description of the Monitor	5
Front Panel Keys	5
Front of Monitor	5
Back of Monitor:	6
A Quick Description of the Measurement Server	7
Overview of the Measurement Server	7
Measurement Connectors for the M3000A #C06, M3001A #C06 and #C18 Measurement Servers	7
Measurement Connectors for the Standard M3000A and M3001A Measurement Server	7
A Quick Description of the Measurement Server Extension.	9
Overview of the Measurement Server Extensions M3015A & M3016A	9
Measurement Connectors for the M3015A Measurement Server Extension	9
Measurement Connectors for the M3016A Measurement Server Extension	10
A Quick Description of the Main Screen.	10
Theories of Operation and Functional Descriptions	11
Section 1 - Monitor Description.	11
Monitor Theory of Operation.	12
Display and User Interface Software Module	13
Alarm Manager Software Module	13
Admit / Discharge / Transfer (ADT) Software Module	13
Trend Software Module	13
Events Software Module	13
Printer Manager	14
Recorder Manager	14
IrDA/Serial Communication Manager	15
Communication Software Module	15
Support Services	15
Functional Description of the Monitor Hardware	16
Display Video Controller	17
Human Interface Controller	18
Battery Controller	18
ECG Out/Marker In Controller	18
Infrared (IrDA) Interface	19
Serial Interface	19
Wireless LAN Interface	19
Section 2 - Measurement Server Description and Features	19
M3001A Measurement Server Standard Package	19
M3001A Measurement Server Extended Measurements Packages	20

M3000A Measurement Server Standard Package	20
M3000A #C06 Measurement Server Extended Measurements Package	20
Features	20
Measurement Server Theory of Operation	21
Functional Description of the Measurement Server Hardware	22
Electrocardiogram/Respiration (ECG/Resp) Measurement	23
Description	23
Measurements	23
ECG/Resp Features	24
Block Diagram of the ECG/Resp	25
Theory of Operation	25
Non-invasive Blood Pressure (NBP) Measurement	29
Description	29
Measurements	29
NBP Features	29
Block Diagram for NBP	31
Components	31
NBP Measurement Characteristic	32
Theory of Operation	32
Arterial Oxygen Saturation and Pleth (SpO ₂ /PLETH) Measurement	33
Description	33
Measurements	33
SpO ₂ /PLETH Features	33
Block Diagram of the SpO ₂ /PLETH Circuit	34
Theory of Operation	34
Temperature and Invasive Blood Pressure (Temp/Press) measurement	37
Description	37
Measurements	37
Temp/Press Features	37
Block Diagram	38
Theory of Operation	38
Temperature and Invasive Pressure Software	39
Block Diagram of the Temp/Press Software	40
Invasive Pressure Software Module	41
Temperature Software Module	42
Section 3 - Measurement Server Extensions Description and Features	44
Features	44
M3015A Measurement Server Extension Theory of Operation	45
Functional Description of the M3015A Measurement Server Extension Hardware	46
Hardware Block Diagram	47
Sidestream CO ₂ Measurement	48
Description	48
Measurements	48

Sidestream CO ₂ Features	49
Block Diagram of the Sidestream CO ₂ measurement	51
Theory of Operation for M3015A Sidestream CO ₂	51
M3016A Measurement Server Extension Theory of Operation	53
Functional Description of the M3016A Measurement Server Extension Hardware	54
Hardware Block Diagram	55
Mainstream CO ₂ Measurement	56
Description	56
Measurements	56
Mainstream CO ₂ Features	57
Block Diagram of the Mainstream CO ₂ measurement	59
Theory of Operation for the M3016A Mainstream CO ₂	60
Tutorial for the Introduction to the Instrument	61
Answers to the Tutorial for the Introduction to the Instrument	62
2 Installing the Instrument.	63
Objectives.....	63
Concepts.....	63
Safety	64
Patient Safety	64
Patient Leakage Current	64
Preparing to Install the Monitor.....	64
Power Source Requirements	64
Protecting against Electric Shock	64
.....	65
Equipotential Grounding	65
Combining Equipment	65
Environment	66
Explanation of symbols used:	67
Unpacking the Monitor	70
Installing the Monitor.....	70
Connecting the Measurement Server.....	71
...with the Measurement Server directly on the Monitor	71
...with the Measurement Server Separate from the Monitor	73
...with the Measurement Server Attached to an M3015A/M3016A Measurement Server Extension	74
Attaching the Monitor to a Mount	74
Detaching the Monitor from a Mount	74
Attaching the Measurement Server to a Mount	75
Detaching the Measurement Server from a Mount	75
Positioning the Measurement Server on a Clamp Mount	75
Connecting to the Nurse Call Relay.....	76
Modification for Nurse Call Alarm Relays	76
Verification Procedure	78

Installation of Wireless Infrastructure	78
Configuring the Radio Frequency of the M3/M4 Monitor	78
Connecting to the ECG Output or Marker Input	87
Configuring the Monitor	87
Selecting NBP Measurement Characteristic	87
Installing an Additional Display	90
Displays	90
Safety Specification	92
Installation	92
Installing the 12V Adapter.	93
Using the Battery Charger and Conditioner	93
Connecting a Printer	93
Selecting a Printer	93
Installing the Wireless Infrared Printer Connector (M3080A #H05)	94
Connecting a Local Printer	95
Connecting a Remote Printer.	96
Connecting a Local Recorder	96
Site Preparation Guidelines	97
Mounting Solutions	98
Installing the Table Mount (M3080A #A10).	98
Installing the Universal Bed Hanger (M3080A #A11)	99
Warnings, Cautions, and Safety Precautions Relating to Wall Mount Installation.	100
Installing the Wall Rail (M3080A #A13)	101
Installing the Tilt/Swivel Mount (M3080A #A14)	101
Screwed Directly to a Wall	102
Mounted to the GCX Wall Channel (M3080A #A15)	103
Attached to a Universal Pole Clamp	104
Attached to the Monitor	105
Installing the GCX Wall Channel (M3080A #A15)	106
Installing the Universal Pole Clamp (M3080A #C05)	107
Installing the Measurement Server Mounting Options	108
Server Mounting Plate (M3080A #A01)	108
Server Mounting Plate (M3080A #A02)	111
Mounting Options for the Local Recorder.	111
MSL Cable Termination	112
Disposing of the Monitor, Measurement Server and Measurement Server Extensions	115
Tutorial for Installing the Instrument	116
Answers to the Tutorial for Installing the Instrument	117
3 Maintaining the Instrument.	119
Objectives	119
Concepts	119
Recommendations for Maintenance Frequency	120
Maintenance Checklist.	121

Inspecting the Instrument	122
Inspect Cables and Cords	122
Preventive Maintenance Tasks	123
M3046A	123
M3000A / M3001A	123
Replacement of the Pump and CO ₂ Scrubber	125
Replacement of the Infrared Lamp	125
General Cleaning of the Instrument	125
Cleaning Guidelines	125
Cleaning Agents	126
Battery Handling, Maintenance and Good Practices	127
About the Battery	127
Checking the Battery Status	127
Charging the Battery	129
Conditioning a Battery	130
Accessing the Battery Status Window	132
Battery INOP Messages	134
Tutorial for Maintaining the Instrument	135
Answers to the Tutorial for Maintaining the Instrument	136
4 Testing the Instrument	137
Objectives	137
Concepts	137
Test Reporting	138
Recommendations for Test Frequency	139
Test Map	140
Testing Checklist	141
Serial Numbers	142
Passwords	142
Visual Test	142
Power On Test	142
Functionality Assurance Tests	143
Performance Assurance Test	143
Quick System Check	143
System Self-Test	144
System Self-Test Values	145
Preventive Maintenance Tests	146
NBP Accuracy, Leakage, Linearity and Valve Test	146
Sidestream CO ₂ Performance Test	148
Checking and Resetting Time Counters	153
Documenting CO ₂ Test Results	154
Accuracy and Performance Procedures	155
Temperature Accuracy	155
ECG/Resp Performance	155

Invasive Pressure Performance Test	156
SpO ₂ Performance Test	157
Mainstream CO ₂ Performance Test	157
Nurse Call Relay Performance Test	157
ECG Sync Performance Test	158
Patient Safety Checks	159
Warnings, Cautions, and Safety Precautions	159
Safety Test Procedures	159
Tutorial for Testing the Instrument	163
Answers to the Tutorial for Testing the Instrument	164
5 Troubleshooting the Instrument	165
Objectives	165
Concepts	165
Part 1 Troubleshooting Checklists	166
Checks for Obvious Problems	166
Checks Before Opening the Instrument	166
First Steps	173
Initial Instrument Boot Phase	173
Isolating Problems to the Correct Subassembly	175
Part 2 Isolating and Solving Instrument Problems	177
INOP Messages	177
Isolating the Defective Component	183
Part 3 Using Support Functions	197
The Status Log and Error Codes	197
List of Error Codes	199
Testing Wireless Network Connectivity	204
Antenna Check	204
Using Service Mode	206
Service Mode Hardware Tests	206
How To Access the Monitor and Server Revision Screen	209
Troubleshooting the Installed Instrument	210
Troubleshooting with Self-Test Alarm Messages (When You Switch the Monitor On)	210
Troubleshooting When There is No Message on the Screen	213
Troubleshooting During/After a Software Upgrade	214
Troubleshooting the Printer Connection	214
Troubleshooting the Recorder Connection	215
Tutorial for Troubleshooting the Instrument	217
Answers to the Tutorial for Troubleshooting the Instrument	218
6 Repairing the Instrument	219
Objectives	219
Concepts	219

Warnings, Cautions and Safety Precautions	220
General Reassembly/Refitting Comments	220
Disassembly for the Monitor	221
Removing the Battery	221
Removing the Power Supply	221
Removing the Chassis	222
Removing the System Board	224
Removing the Wireless Assembly (for Monitors with Wireless LAN Interface only)	226
Removing the LCD Assembly and Backlight Tubes	226
Removing the Connector Board	228
Removing the Speaker	229
Refit Procedures for the Monitor	230
Refitting the System Board	230
Refitting the LCD Assembly and Backlight Tubes	230
Refitting the Connector Board	230
Refitting the Speaker	230
Refitting the Power Supply	230
Refitting the Wireless Assembly	231
Refitting the Chassis	231
Refitting the Battery	231
Disassembly Procedures for the M3015A Measurement Server Extension	232
Removing the Front Cover	232
Removing the Extension Bottom Cover	233
Removing the CO ₂ Scrubber	235
Removing the Pump	236
Refit Procedures for the M3015A Measurement Server Extension	237
Refitting the CO ₂ Scrubber	237
Refitting the Pump	238
Refitting the Extension Bottom Cover	238
Refitting the Front Cover	238
Disassembly Procedures for the M8043A Battery Charger and Conditioner	239
Opening the Housing	239
Removing the Cooling Fans	240
Removing the Air Filters	242
Reassembling the Battery Charger and Conditioner	242
Following Reassembly	242
Tutorial for Repairing the Instrument	243
Answers to Tutorial for Repairing the Instrument	244
7 Replacement Parts	245
Objectives	245
Compatibility Matrix - Release A to Release B	245
List of Replacement and Exchange Parts	247
Monitor Parts	248

Bezel Parts	248
Other Monitor Parts	250
Monitor Exchange Parts	251
Small Parts Kit	253
Multi-Measurement Server Parts.....	254
M3001A Part Numbers - Front Bezel	254
M3001A MMS Part Numbers - IntelliVue Software Revision A.05.xx and Lower ..	256
M3001A MMS Part Numbers - IntelliVue Software Revision A.10.xx and Higher ..	259
M3015A Measurement Server Extension Parts.....	266
M3015A Parts	266
M3015A Exchange Parts	268
M3016A Measurement Server Extension Parts.....	270
M3016A Parts	270
M3016A Measurement Server Extension Exchange Parts	271
Support-Related Parts	272
Cables and MSL Through Wall Installation Parts.....	272
MMS Measurement Server Link (MSL) Cable Clamp Kit.....	273
Wireless Assembly Exchange Parts.....	273
Battery and Battery-Related Parts	274
Battery Parts	274
Battery Exchange Parts	274
Battery Charger and Conditioner Parts	274
XE-50p Recorder Exchange Parts	274

1 Introduction to the Instrument

Objectives

In order to meet this chapter's goals, you should become familiar with the Monitor, Measurement Server and the Measurement Server Extensions, and be able to identify their component parts in some detail. As well, you should be able to explain how the Measurement Server and Measurement Server Extensions acquire and process physiological measurements and how the Monitor displays the data.

The following topics are covered in this chapter:

- Introducing the Instrument Components
- Section 1 - Monitor Description
 - Functional Description of the Monitor Hardware
- Section 2 - Measurement Server Description and Features
 - Measurement Server Theory of Operation
 - Functional Description of the Measurement Server Hardware
 - Electrocardiogram/Respiration (ECG/Resp) Measurement
 - Non-invasive Blood Pressure (NBP) Measurement
 - Arterial Oxygen Saturation and Pleth (SpO2/PLETH) Measurement
 - Temperature and Invasive Blood Pressure (Temp/Press) measurement
- Section 3 - Measurement Server Extensions Description and Features
 - M3015A Measurement Server Extension Theory of Operation
 - Functional Description of the M3015A Measurement Server Extension Hardware
 - Sidestream CO2 Measurement
 - M3016A Measurement Server Extension Theory of Operation
 - Functional Description of the M3016A Measurement Server Extension Hardware
 - Mainstream CO2 Measurement

Concepts

The following section contains information that you need to understand in order to competently maintain and repair an M2, M3 or M4 Monitor and Measurement Server with or without a Measurement Server Extension.

Theory of Operation The theory of operation for a component describes the processing of signals within the component.

Functional Description The functional description of a component uses a diagram of the circuitry followed by short, written explanations of the component circuitry.

Introducing the Instrument Components

The M3046A Compact Portable Patient Monitor together with the Multi-Measurement Server (M3000A or M3001A) and the M3015A and M3016A Measurement Server Extensions forms a flexible, portable, battery or line powered patient monitor. The combined devices are referred to as the *Instrument* in this manual.

The M3000A Multi-Measurement Server can be used with M3046A patient monitors up to and including Release D, but is incompatible with Release E monitors. All equipment from Release C and D (M3046A monitors and the Release C M3000A Measurement Server) must be used in monitoring configurations where only Release B, C or D software equipment is included. None of these parts are compatible with Release A software.

The M3001A Multi-Measurement Server is compatible only with the Release E M3046A monitors, and is incompatible with any earlier releases.

The Hemodynamic Extension M3012A is for use together with the Multi-Measurement Server M3001A. This combination supports the transfer of patient data between IntelliVue (M80xxA) and M3/M4 (M3046A, Revision E) monitors. The M3012A's Pressure/Temperature channel works in the same way as that of the M3001A, with which the M3012A shares all specifications, as documented in the M3/M4 *Instructions for Use*, except for the weight, which is 450g (0.99lb). See the table below for supported parameters. The M3012A is not further covered in this Service Guide.

To check which software revisions are on your equipment, enter Setup and select **Revisions**.

The Multi-Measurement Server and Server Extensions acquire the following physiological signals:

Measurement Server/Server Extension with Option	Measurements									Compatible with which M3046A Release?	
	3-Channel ECG	EASI derived ^a 12-Lead ECG	Respiration	Non-Invasive Blood Pressure	Oxygen Saturation SpO ₂	Invasive Blood Pressure	Temperature	Mainstream CO ₂	Sidestream CO ₂	D and lower	E
M3000A	✓	x	✓	✓	✓	x	x	x	x	✓	x
M3000A #C06	✓	x	✓	✓	✓	✓	✓	x	x	✓	x
M3001A	✓	✓	✓	✓	✓	x	x	x	x	x	✓

Measurement Server/Server Extension with Option	Measurements									Compatible with which M3046A Release?	
	3-Channel ECG	EASI derived ^a 12-Lead ECG	Respiration	Non-Invasive Blood Pressure	Oxygen Saturation SpO ₂	Invasive Blood Pressure	Temperature	Mainstream CO ₂	Sidestream CO ₂	D and lower	E
M3001A #C06	✓	✓	✓	✓	✓	✓	✓	x	x	x	✓
M3001A #C12	✓	✓	✓	✓	✓	x	x	x	x	x	✓
M3001A #C18	✓	✓	✓	✓	✓	✓	✓	x	x	x	✓
M3012A ^b	x	x	x	x	x	✓	✓	x	x	x	✓
M3015A ^c	x	x	x	x	x	x	x	x	✓	✓	✓
M3015A #C06 ^c	x	x	x	x	x	✓	✓	x	✓	✓	✓
M3016A #A01 ^c	x	x	x	x	x	✓	✓	✓	x	✓	✓
M3016A #A02 ^c	x	x	x	x	x	✓	✓	x	x	✓	✓
Key:	✓ = supported			x = not supported							

- a. Using a standard 5-electrode lead set. You can connect a 10-electrode lead set (for example, if a patient is transferred from an IntelliVue monitor), but only the standard five electrodes (RA, LA, RL, LL, and V) are used for monitoring. The rest are automatically ignored.
- b. Only Pressure/Temperature supported in M4 monitors.
- c. Support for the CO₂ measurement depends on the monitor option and software revision. Compatible with M3/M4 with software revision E and D (later than D.11). Compatible with M4 only with software revision B to D.11. No support for CO₂ for earlier monitors with software revision A.

The signals are converted into digital data, and processed before being communicated to the Monitor. The server device is referred to as the Measurement Server or simply the *Server* in this manual. All versions of the M3000A and M3001A Measurement Servers are covered by this manual.

When using the M3015A and M3016A, all the signals are converted into digital data, and processed before being communicated to the Monitor. Server extension devices are referred to as the Measurement Server Extensions or simply *Extensions* in this manual.

The M3046A Compact Portable Patient Monitor receives the processed data from the Measurement Server and the Measurement Server Extension, examines it for alarm conditions, and displays it. The Monitor also provides operating controls for the user, and interfaces to other devices. This monitoring device is referred to as the Monitor in this manual.

The M3080A #C32 12V adapter allows use of a vehicle power supply for the instrument and the M8043A Battery Charger and Conditioner allows the recharging and conditioning of batteries of the instrument.

Instrument Components

The Monitor, the Measurement Server, and Measurement Server Extensions are shown in the following diagram:

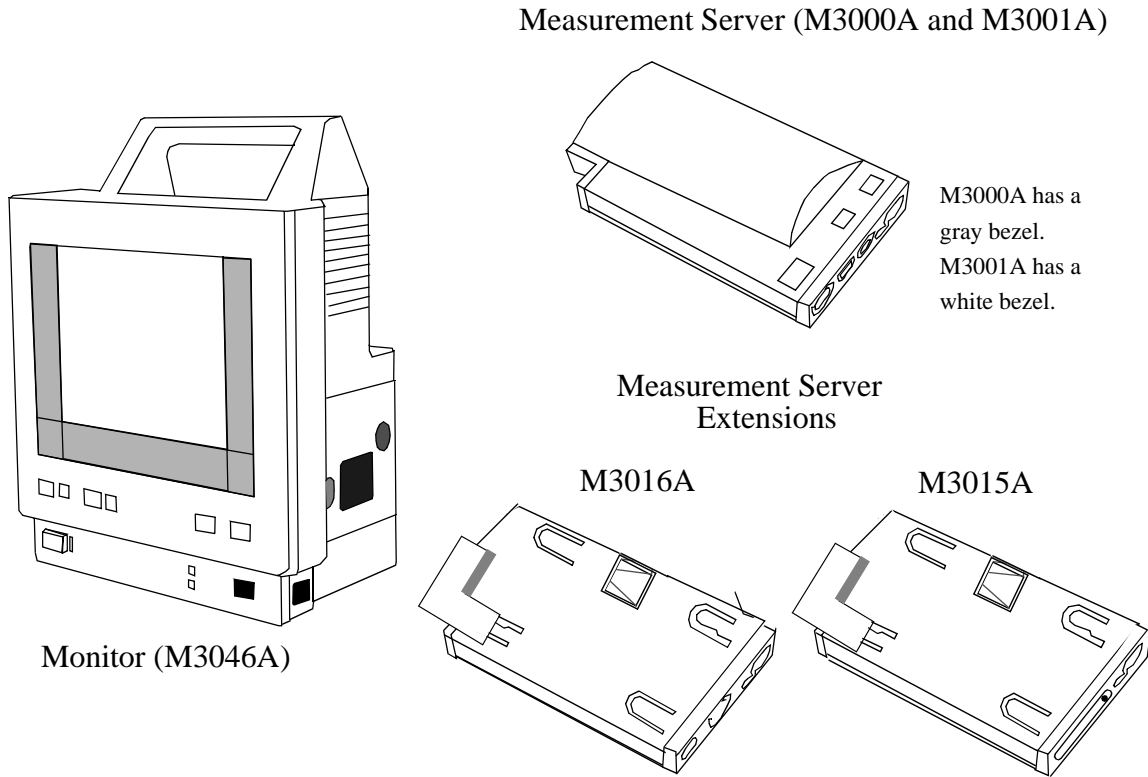

Functional descriptions of these components are to be found later in this chapter.

A Quick Description of the Monitor

Front Panel Keys

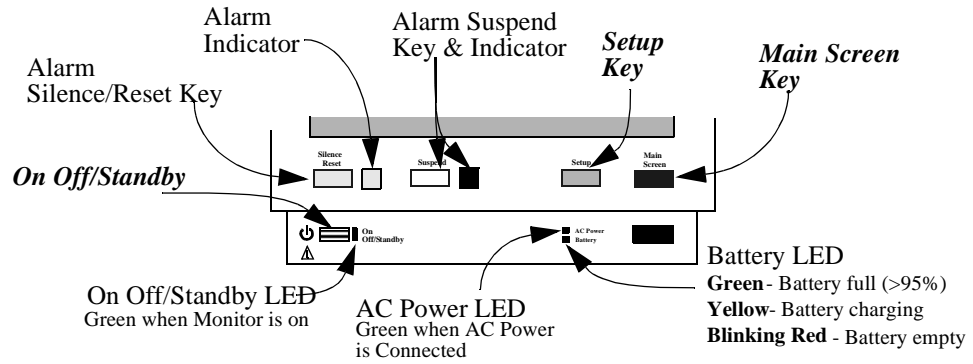

Front of Monitor

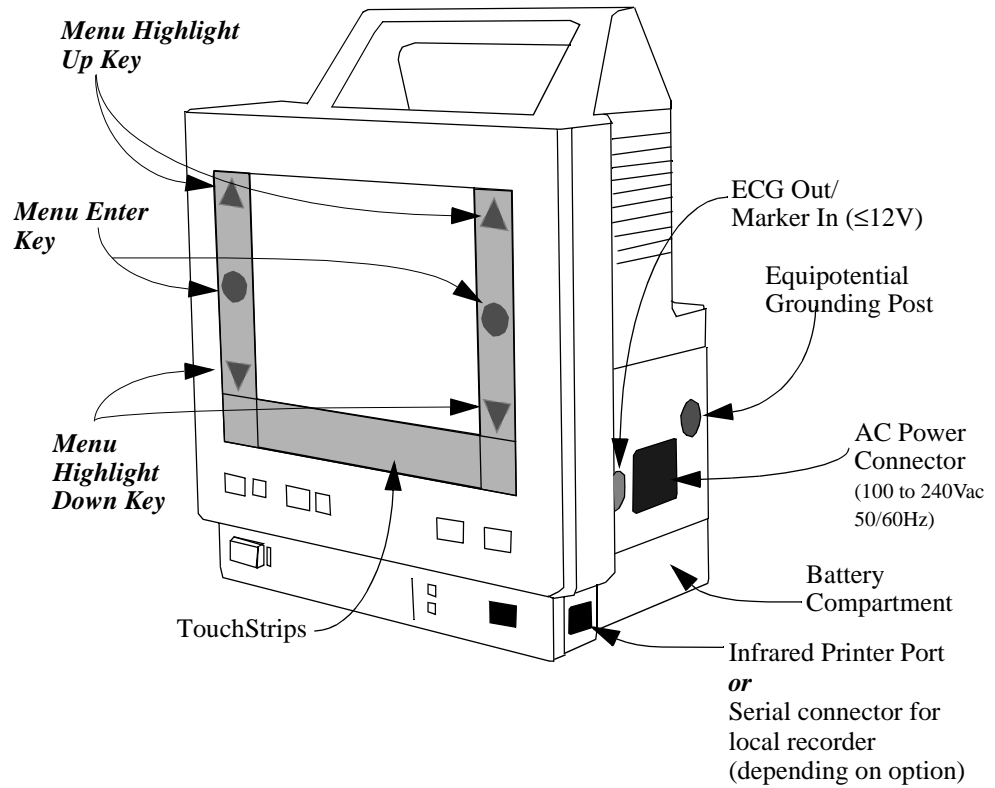

Back of Monitor:

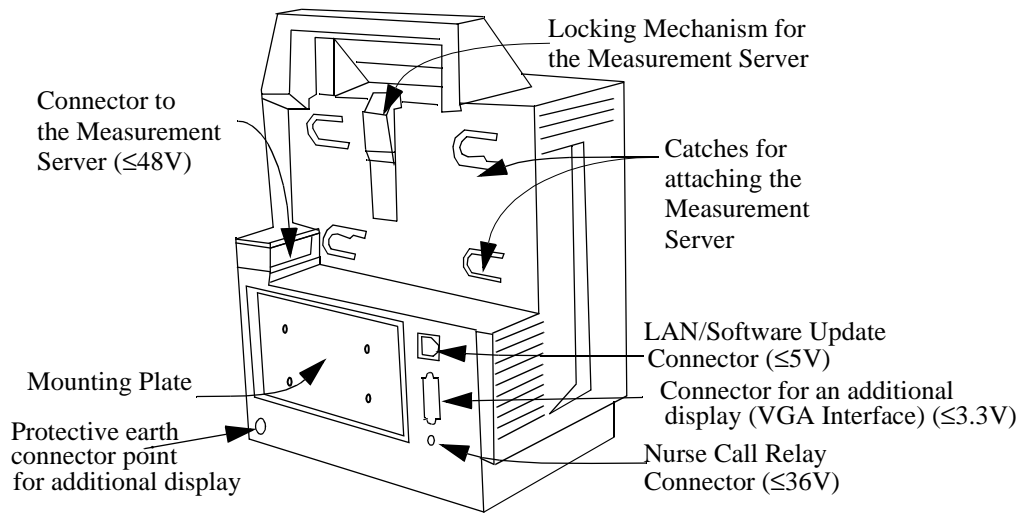

A Quick Description of the Measurement Server

Overview of the Measurement Server

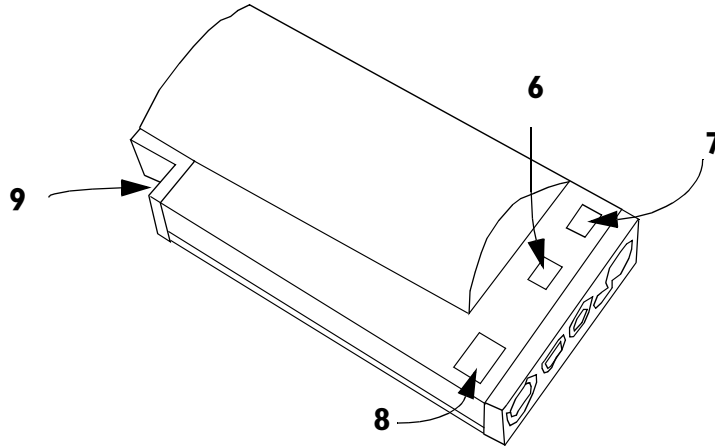

Measurement Connectors for the M3000A #C06, M3001A #C06 and #C18 Measurement Servers

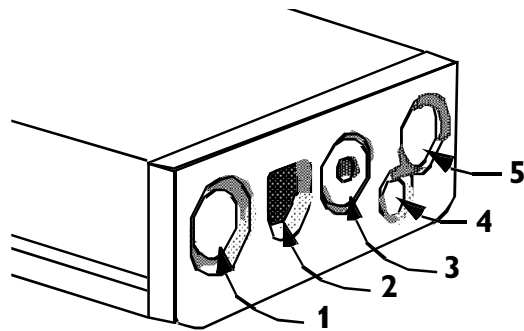

Note:
Press and Temp cannot
be used at the same time.

Measurement Connectors for the Standard M3000A and M3001A Measurement Server

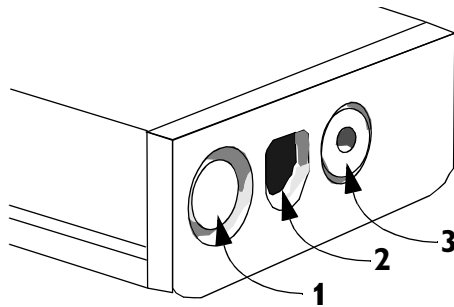

M3001A Connectors and Keys			
1	White ECG/Resp connector.	6	NBP Start/Stop key - starts or stops NBP measurements.
2	Blue SpO ₂ connector	7	<i>Either:</i> NBP STAT key - starts NBP STAT series of measurements. <i>or</i> Zero key - initiates a zero procedure for the connected pressure transducer when pressed and held for a second.
3	Red NBP connector	8	Alarm Silence/Reset
4 & 5	Combined pressure (red) and temperature (brown) connector - connect either invasive pressure transducer or temperature probe (M3000A #C06; M3001A #C06 and #C18 only). Press and temp cannot be used at the same time. You might have a version of the Measurement Server that does not have this connector.	9	MSL cable connector to the monitor.

A Quick Description of the Measurement Server Extension

Overview of the Measurement Server Extensions M3015A & M3016A

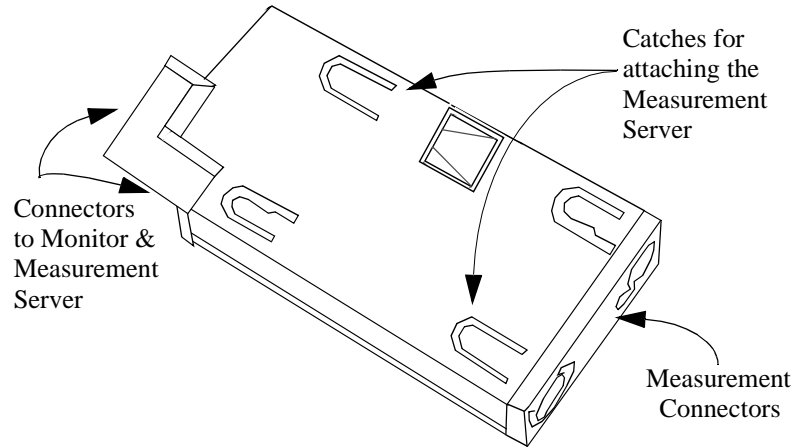

Measurement Connectors for the M3015A Measurement Server Extension

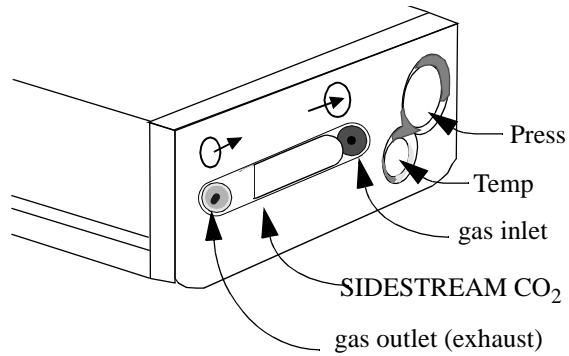

Note:
Press and Temp (M3015A #C06 only)
cannot be used at the same time on
the same Extension.

Measurement Connectors for the M3016A Measurement Server Extension

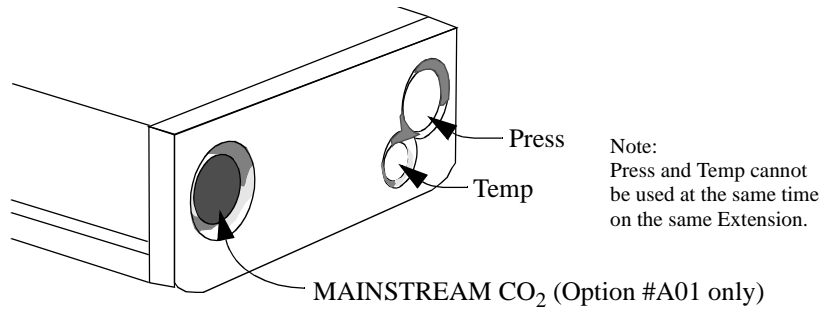

A Quick Description of the Main Screen

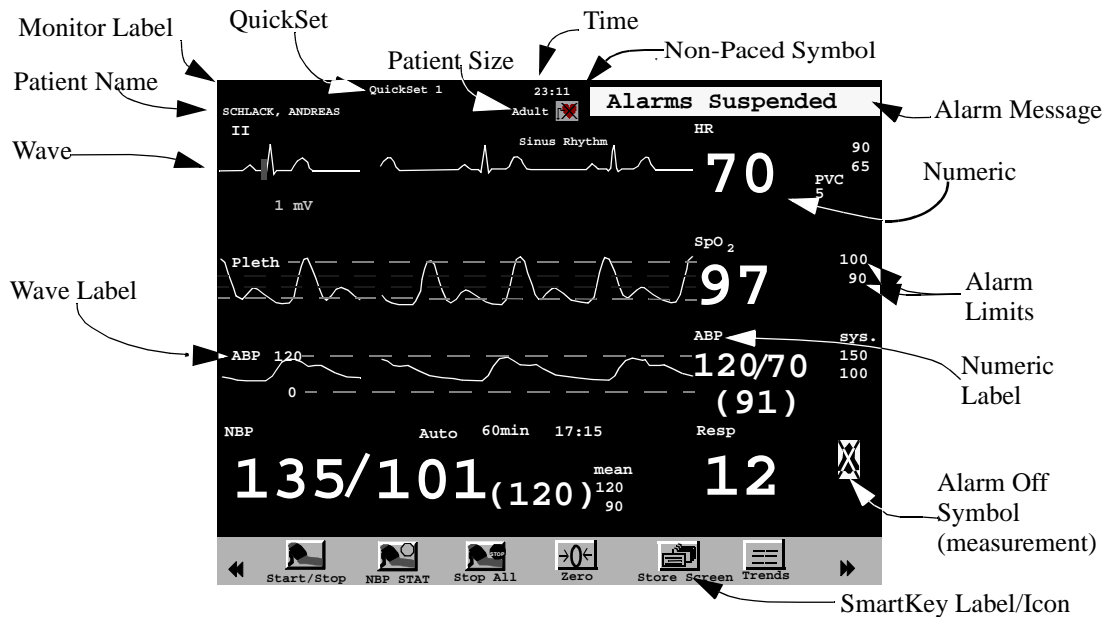

You can return to the display with the waves and the numerics at any time by pressing the blue **Main Screen** key.

Theories of Operation and Functional Descriptions

The theories of operation and functional descriptions are presented in three sections:

Section 1 Monitor Description

- M3046A Monitor Theory of Operation
- Functional Description of the Monitor Hardware

Section 2 M3001A/M3000A Measurement Server Description and Features

- Measurement Server Theory of Operation
- Functional Description of the Measurement Server Hardware
- Electrocardiogram/Respiration (ECG/Resp) Measurement
- Non-invasive Blood Pressure (NBP) Measurement
- Arterial Oxygen Saturation and Pleth (SpO2/PLETH) Measurement
- Temperature and Invasive Blood Pressure (Temp/Press) measurement

Section 3 Measurement Server Extensions Description and Features

- M3015A Measurement Server Extension Theory of Operation
- Functional Description of the M3015A Measurement Server Extension Hardware
- Sidestream CO2 Measurement
- M3016A Measurement Server Extension Theory of Operation
- Functional Description of the M3016A Measurement Server Extension Hardware
- Mainstream CO2 Measurement

Section 1 - Monitor Description

The M3046A Patient Monitor is a small size, lightweight monitor with a TouchBar human interface. The monitor has a color display with a wide viewing angle, and excellent visibility from a distance, so that data can easily be recognized. For applications where a larger display is required, an additional display can be connected to the monitor via the standard VGA output.

Trend data, and manual and automatic event storage, together with a range of report styles are available for tracking and documenting the patient's progress.

The Monitor receives the processed data from the Measurement Server and the Measurement Server Extension, examines it for alarm conditions, and displays it. The Monitor also provides operating controls for the user, and interfaces to other devices.

Monitor Theory of Operation

The Monitor receives data passed from the patient through the Measurement Server and, where present, the Measurement Server Extension. The Monitor displays the data in numerics and waves on the screen.

The Monitor is prepared with a number of software modules, which communicate with each other as shown in the diagram below. The Monitor software communicates with the Measurement Server and, where present, the Measurement Server Extension via a normal local area network (LAN) link. Data from the Monitor can be output to a printer via an infrared serial link or via the LAN connector to a central print server. The Monitor can communicate with an Philips Information Center via the LAN Connector (wired network) or via the Wireless LAN Assembly (wireless network) when the appropriate options are present.

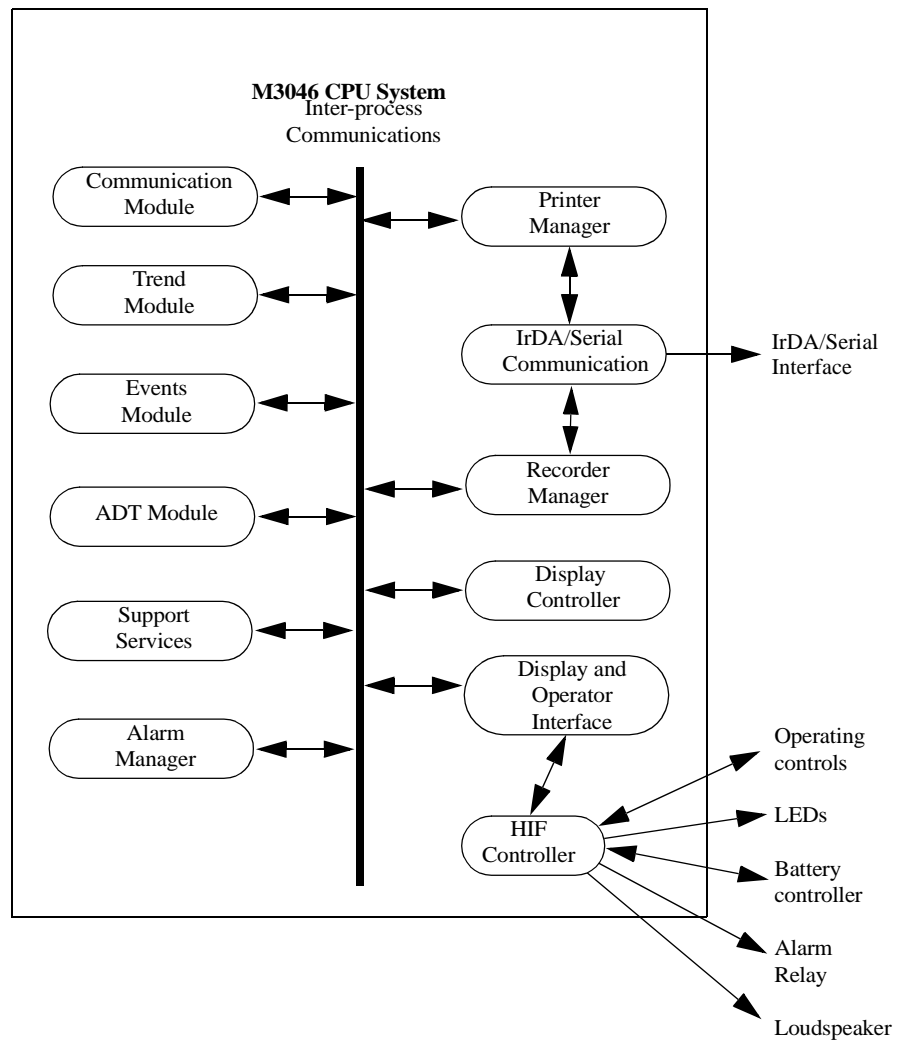

Each of these modules is described in the following sections.

Display and User Interface Software Module

The Display and User Interface Software displays measurement data and status information on the color LCD display, and processes the operator inputs from the HIF Controller. The interface consists of the following sub-modules:

- Screen Configuration.
- Numerics and Wave Presentation.
- Key and TouchStrip Processing.
- Alarm and Status Presentation.

Alarm Manager Software Module

The visual and audible alarms generated by the Measurement Server, the Measurement Server Extension or by the Monitor software modules are assigned priorities by the Alarm Manager. The Alarm Manager also:

- Monitors the “alarm suspended”, “alarm silence” and “alarm reminder” functionality.
- Manages alarm latching (alarms remain in effect until reset or turned off by the user).
- Triggers the Nurse Call Relay.
- Generates alarm event triggers for any user-defined trigger conditions.

Admit / Discharge / Transfer (ADT) Software Module

This module maintains the patient’s demographics and controls the upload of trend data from the Measurement Server and the Measurement Server Extension. It allows the user to:

- Admit a new patient.
- Transfer a patient to another Monitor.
- Discharge a patient.

Trend Software Module

This module manages a trend database. It stores physiological values from the Measurement Server and from the Measurement Server Extension in two separate databases, a short-term and a long-term database. The contents of these databases is battery-buffered, so that no data is lost in the event of a power failure.

Events Software Module

The events software module allows the user to take snapshots of the Monitor state and store them for later viewing or printing. This can be done automatically, triggered by alarms, if the monitor is configured appropriately. The types of data that can be captured are as follows:

- All physiological values.
- All current alarms.
- The last 20 seconds of wave data.

Printer Manager

The printer manager formats and prints the following reports on either a locally attached printer or a remote printer connected to the Instrument via the M3 Print Server:

- **Tabular Trend Report**—The printer manager takes raw data from the trend module and generates a formatted report. The user can specify whether to print short-term or long-term trend data, and the period for which the data should be printed.
- **Event Report**—The printer manager takes raw data from the event module and generates a formatted event report. The user can specify a manual event, an alarm event, or a print screen report.
- **Event List Report**—The printer manager takes the raw event list data from the events module and generates a formatted event list report.

A number of drawing functions support the printer manager and provide it with graphics capabilities. The output from the printer manager is in PCL (Printer Command Language) format, and is fed to the locally attached printer, which is connected via an infrared data link, or to a remote printer. If the link to the printer is interrupted for a certain time, the printer manager displays a prompt of the color LCD display, notifying the user.

Recorder Manager

The recorder manager formats and records the following on a local recorder:

- **Real-time or Delayed Recording**—The user can select between a real-time local recording or a delayed recording.
A real-time recording is started by pressing the **Local Record** SmartKey. When a recording is running, you can stop it by pressing the key again.
A delayed recording can be started by pressing the **Local Delayed** SmartKey. Pressing the key again will extend the recording.
- **Tabular Trend Report**—The recorder manager takes raw data from the trend module and generates a formatted report. The user can specify whether to record short-term or long-term trend data, and the period for which the data should be recorded.
- **Event Report**—The recorder manager takes raw data from the event module and generates a formatted event report, and this is recorded on the local recorder.
- **Alarm Recording**—If a local recorder is connected to the monitor via the optional serial interface, you can make local alarm recordings. In configuration mode, you can select the local recorder or the Information Center, or both, to record alarms. If one of the configured alarms occurs, a recording for that alarm is started automatically at the local recorder (and/or requested from the Information Center).

See Chapter 2, Installing the Instrument for more details on connecting to a recorder.

A number of drawing functions support the recorder manager and provide it with graphics capabilities. The output from the recorder manager supports the GSI Lumonics XE-50p-specific serial protocol, and output is fed to the local recorder, which is connected via a dedicated serial cable. The recorder manager displays prompt and status messages on the monitor's color LCD display.

IrDA/Serial Communication Manager

The IrDA/Serial Communication manager is responsible for sending raw data to the local recorder (serial protocol) or printer (in a format that complies with the IrDA (Infrared Data Association) standard). The IrDA/Serial Communication manager provides a general printer or recorder device interface to the printer or recorder manager, and maps the general printer/recorder services to the device protocol. The general printer services are as follows:

- Establishing and terminating the printer/recorder connection.
- Transferring data to the printer/recorder.
- Retrieving the printer/recorder status.

The IrDA/Serial Communication manager feeds the printer/recorder status (time out, paper out, and so on) back to the printer or recorder manager, which in turn notifies the user of any errors in the print/record process.

Communication Software Module

The communication module maintains a data link between the Monitor, the Measurement Server and the Measurement Server Extension, and controls the exchange of data between them. This data includes the following:

- Measurement data.
- status information.
- Control information.
- Configuration data.

Support Services

The support services software module contains miscellaneous functions that both the Monitor, the Measurement Server and the Measurement Server Extension require. These functions are as follows:

- Date and Time.
- Settings Handler.
- Status Revision and Display.
- Heart Rate Selector.

Functional Description of the Monitor Hardware

The Monitor receives data from the Measurement Server and Measurement Server Extension via the Server-to-Monitor link bar and presents this data on the color LCD display. The following block diagram shows the main functional areas.

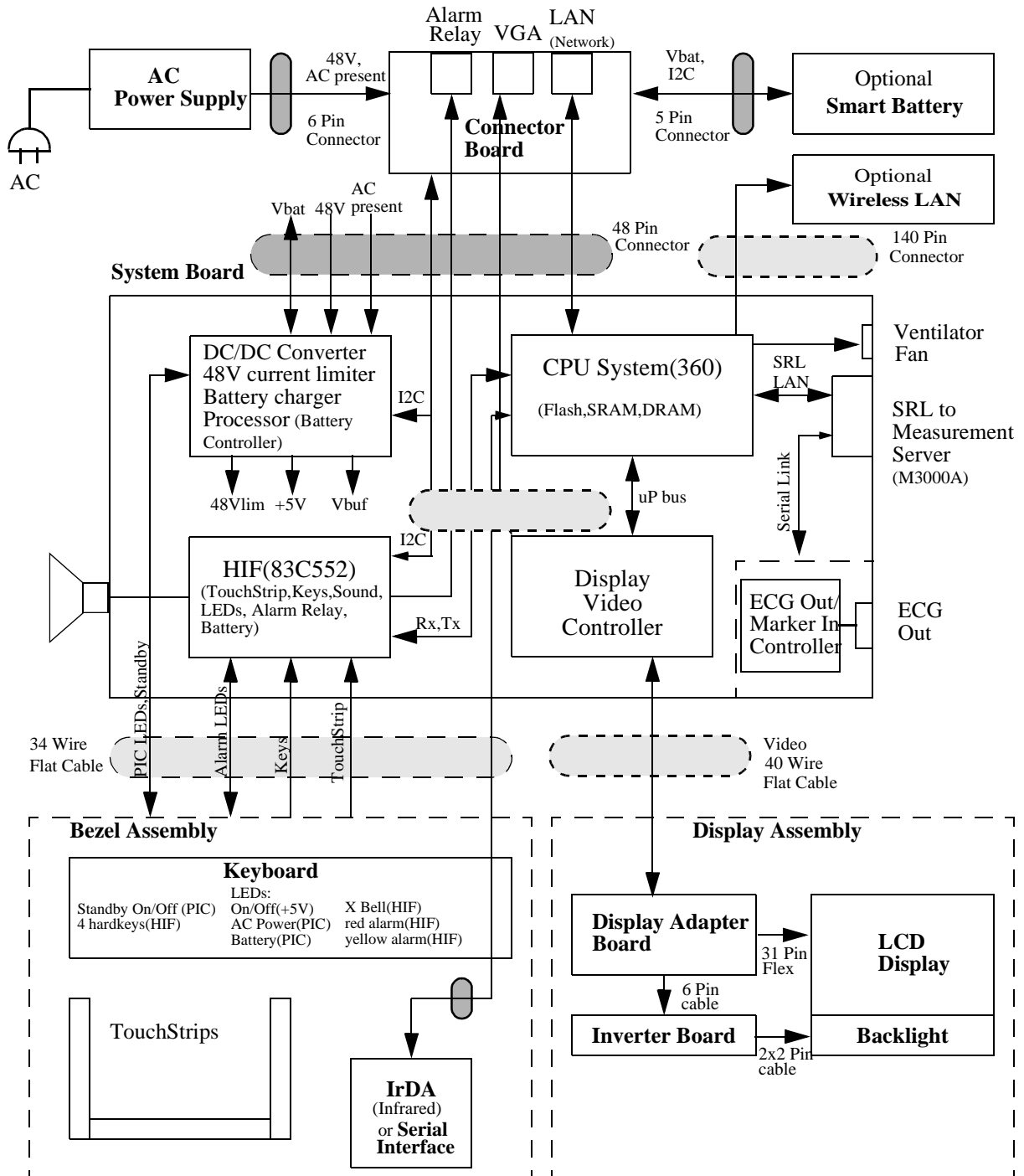

The main functional areas are summarized in the following:

- **System Board**—Comprising a 68360 Controller, the Memory System, the Video System, LAN (network) connector link to Server, ECG-Out, Human Interface and DC/DC Converter.
- **Connector Board**—Connecting the System Board to the AC Power Supply and battery. The LAN (network) filter and connector, the VGA connector and the Alarm Relay Output (Nurse Call) are located on the Connector Board. The Connector Board has a 48-pin connector to the System Board.
- **Display Assembly**—Comprising a 6.5 inch TFT color LCD display (including 2 backlight tubes), the Display Adapter Board and the associated backlight inverter board (generates the high voltage for the tubes). These parts are packed into a soft, rubber-based holder (sometimes referred to as the *cushion*). The LCD display uses *thin-film-technology* and is sometimes referred to as a *TFT* display.
The Display Assembly connects to the System Board via a 40-wire flat ribbon cable.
- **Bezel Assembly**—Comprising the U-shaped TouchStrip, the Keyboard (which includes operating keys, alarm LEDs, On/Off switch and AC and battery indicator LEDs), and the IrDA Board (infrared printer interface) / recorder interface board..
The Bezel Assembly connects to the System Board via a 34-wire flat ribbon cable.
- **Speaker**—Connected to the System Board with a 2-wire cable. The loudspeaker provides the audible output for alarms, and audible feedback when the user presses a manual control.
- **AC Power Supply**—Connected to the Connector Board to power the Instrument and/or charge the battery depending on the operating mode.
- **Smart Battery**—As an option, a standard, intelligent battery with an I2C interface to the DC/DC controller.
- **Wireless LAN Assembly** — Comprising the Wireless LAN CPU Board and the radio frequency (RF) Board. The Wireless LAN Assembly connects to the System Board via a 140-pin extension connector. The RF Board connects to the antenna, which is built into the monitor handle via a coax cable.
- **Ventilator Fan** — Connected to the System Board with a 2-wire cable. The fan controls the temperature inside the Monitor when the Wireless LAN option is installed.

Detailed descriptions are given in the following sections.

Display Video Controller

The Display Video Controller runs the software that controls the display. This software processes the high level display command to generate and format the screen characters, graphics, and wave plots, and also generates the video control signals for the LCD display.

The software continuously checks the functionality of the hardware in the Display Controller, and issues an error indication in the event of a hardware malfunction.

Human Interface Controller

The Human Interface Controller (HIF) is the interface between the operator and the Monitor itself. It monitors the operator controls and the Battery Controller, formats the data, and routes it to the Display & Operator Controls Manager from which it receives commands and status also. As well, the HIF controls the features listed below.

Visual Indicators

The Instrument is fitted with the following front panel indicators:

- **Yellow LED**—This flashes in addition to the visual indication on the LCD display when a yellow-alarm situation occurs (medium severity alarm).
- **Red LED**—This flashes in addition to the visual indication on the LCD display and the audible tone from the loudspeaker when a red-alarm situation occurs (high severity alarm).
- **Crossed Bell LED**—This is illuminated when all alarms have been suspended.

Alarm Relay

In addition to the audible and visual alarms, an alarm relay is provided, which energizes when an alarm condition occurs. This enables a remote alarm indicator (such as a Nurse Call) to be connected to the device.

Battery Controller

The battery controller is the interface to the Smart battery. Signals from the battery inform the battery controller of the most effective charging current with which to load the battery. Two LEDs are mounted on the Battery Controller:

- **Battery LED**—This is illuminated green if the battery is fully charged and yellow if the battery is charging. If the remaining battery-operating time is only 5 minutes, the LED flashes red at a repetition rate of 1.5 flashes per second.
- **AC LED**—This is illuminated green when the power cord is connected and AC power is available. Otherwise it is extinguished. The AC LED is fed directly from the AC power supply.

For a detailed description of the battery, see chapter 3, “Maintaining the Instrument”.

ECG Out/Marker In Controller

The ECG Out/Marker In Controller is the interface between the Monitor and any defibrillator that might be connected. It converts a digital waveform signal received from the Measurement Server ECG/Respiration module into an analog ECG signal, which it feeds to the defibrillator in order to synchronize it. The ECG Out controller also processes the marker information from the defibrillator and feeds the data back to the Measurement Server ECG/Respiration measurement module.

Infrared (IrDA) Interface

The IrDA interface provides a wireless interface to an external printer. This interface functions in the same way as a normal serial interface except that a modulated infrared beam is used to exchange data and status information instead of a wire connection. Both the Monitor and some printers are equipped with infrared transmitter/receiver units.

When using a printer without a built-in infrared interface, an infrared to parallel converter (Jet-Eye, orderable under M3080A Option #H05) is needed. See the *Instructions for Use*, Installation chapter, for details on how to connect the printer using this converter.

Serial Interface

The serial interface allows a local recorder to be connected to the Monitor using a serial cable that supports the GSI Lumonics XE-50p Chart Recorder-specific protocol.

Wireless LAN Interface

The Wireless LAN interface provides a wireless connection to the Philips LAN. The Wireless LAN CPU connects to the wired LAN inside the Monitor and provides the software drivers for the RF Board. The RF Board transforms wired LAN signals into 2.4 GHz signals for transmission. The modulation technique FHSS, frequency hopping spread spectrum, ensures optimum transmission performance.

The 2.4 GHz band is available worldwide for industrial, scientific and medical purposes, and is called the ISM-band.

Section 2 - Measurement Server Description and Features

The Measurement Server is a highly flexible patient measurement unit, which is the base for a variety of systems that enable easy customization to a hospital's requirements. It provides a subset of the most important patient measurements in a convenient, single part.

The Measurement Server is designed to monitor patients in most critical and acute patient care areas of the hospital. Used at the bedside, it is most commonly mounted to a Monitor. It can also be mounted separately on a bed or a roller stand.

There are two different Measurement servers that are used with the M3046A. Compatibility depends on the software revision of the Monitor (see page 2).

M3001A Measurement Server Standard Package

The Measurement Server (M3001A) standard package includes:

- Measurements of ECG (including derived EASI)/Resp, NBP, and SpO₂.
- Signal and alarm processing.

M3001A Measurement Server Extended Measurements Packages

All versions of the M3001A Measurement Server offer EASI lead placement using an EASI 5-electrode cable set. The conventional 12-lead ECG capability of M3001A #C12 and #C18 only works with the IntelliVue family of monitors. You can connect a 10-electrode lead set (for example, if a patient is transferred from an IntelliVue monitor), but only the standard five electrodes (RA, LA, RL, LL, and V) are used for monitoring. The rest are automatically ignored.

M3001A #C06:

- Standard package *plus* Press and Temp.

M3001A #C12:

- As standard package for M3/M4. Conventional 12-Lead ECG when used with IntelliVue.

M3001A #C18:

- As standard package *plus* Press, Temp for M3/M4. Conventional 12-Lead ECG when used with IntelliVue.

M3000A Measurement Server Standard Package

The Measurement Server (M3000A) standard package includes:

- Measurements of ECG/Resp, NBP, and SpO₂,
- Signal and alarm processing.

M3000A #C06 Measurement Server Extended Measurements Package

The Measurement Server (M3000A #C06) optional package includes:

- Measurements of ECG/Resp, NBP, SpO₂, Press, and Temp,
- Signal and alarm processing.

Features

The Measurement Server has the following general features:

Data Management

The Measurement Server features Patient Data Management. This consists of continuous 4-hour storage of patient-related measurement information. This allows you to do the following:

- Manage patient information,
- View patient data in tabular form via the Monitor,
- Print patient information reports via the Monitor,

- Transfer data between Monitors. The M3001A supports data transfer to and from the IntelliVue family of patient monitors.

Settings Transfer

The Measurement Server can be transported from one Monitor to another and still keep its measurement settings. The settings (such as alarm limits) are stored inside the server. This behaviour permits fast and easy transport.

Alarms Reset

The Silence/Reset key on the Measurement Server allows you to silence alarm tones, while retaining visual alarm messages (depending on your Monitor's configuration).

Server-to-Monitor Link Bar

A single connector (sometimes referred to as the *Server-to-Monitor* connector or link bar) allows quick and easy connection to a Monitor. This allows the Monitor to show waves and alarms from the Measurement Server.

The interface subsystem consists of the physical interface to the Monitor or the Measurement Server Extension and controlling software.

Digitized patient information transmitted over the link bar may be waves (for ECG, pressure, respiration, pleth); numeric information (for heart rate/pulse, pressure values, SpO₂ and respiration rate); or alert information (for alarms and assorted status information).

For Service Procedures there is a special Service Link Bar, which is used in place of the standard Link Bar.

Measurement Server Theory of Operation

The Measurement Server is prepared with software divided into four major conceptual layers. The Measurement Server software communicates with the Monitor via a normal local area network (LAN) link. The four conceptual layers of the Server software are divided as follows:

- **The First Layer**—This consists of the operating system which passes messages between the various major sections of the software. As well, the operating system performs system initialization, background error checking, and checking while the software is running.
- **The Second Layer**—This consists of the monitoring management system. This layer includes the following software:
 - . Alarm software.
 - . Record software.
 - . Trend database software.

- Heart rate software.
- **The Third Layer**—This consists of the interface management and interface controllers. This layer contains the date/time, and Server-to-Monitor link managers.
- **The Fourth Layer**—This consists of the monitoring algorithms and software to acquire the physiological signals.

Functional Description of the Measurement Server Hardware

The Server receives information signals (such as ECG, etc.) from the patient, performs some data processing, then transmits the data to the Monitor via the Server-to-Monitor link bar. The following block diagram shows the main functional components of the Measurement Server.

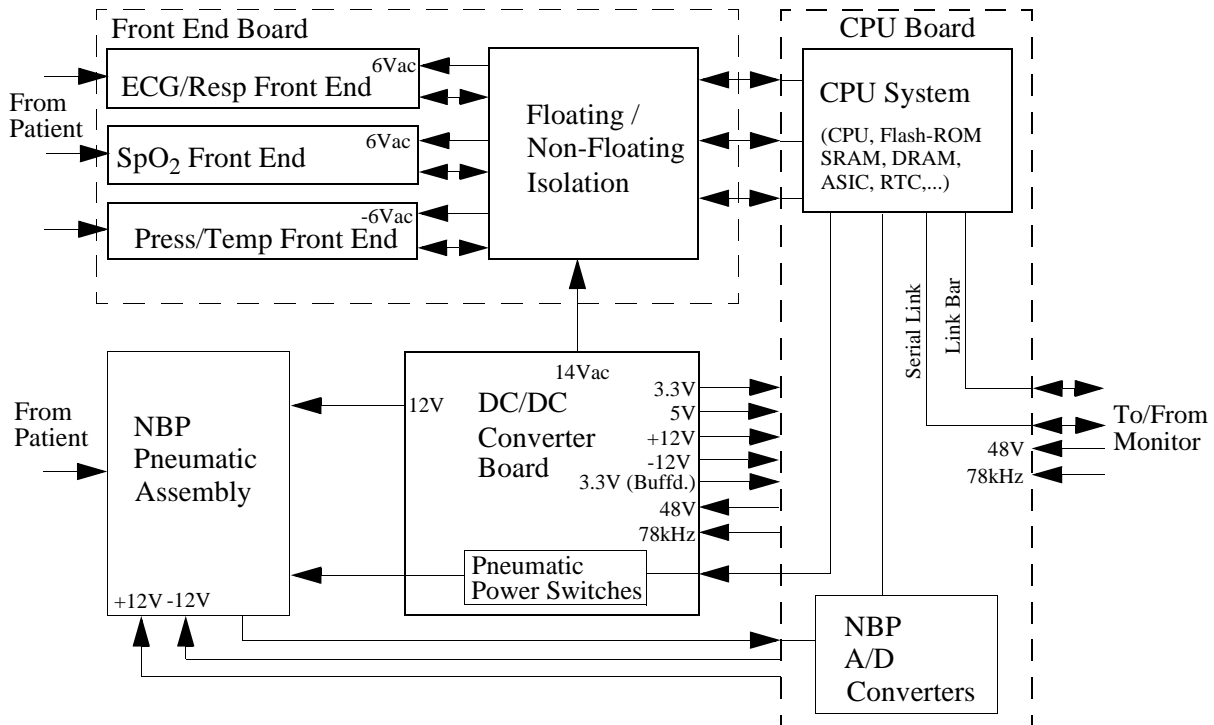

The main functional areas are summarized below:

- **CPU Board**—Consisting of a 68360 Controller, the Memory System (Flash ROM, SRAM, DRAM, ASIC, RTC, etc.), the NBP A/D Converters, and a connector link to a Monitor or an Extension.

- **Front End Board**—Consisting of the ECG/Resp Front End, the SpO₂ Front End, the Press/Temp Front End and the Floating/Non-Floating Isolation area all feeding signals to the CPU Board.
- **NBP Pneumatic Assembly**—Connecting to the DC/DC Converter Board, the Pneumatic Power Switches housed in the DC/DC Converter Board and to the NBP A/D Converters.
- **DC/DC Converter Board**—Connecting to the Floating/Non-Floating Isolation area on the Front End Board, to the NBP Pneumatic Assembly and to the CPU System.

Electrocardiogram/Respiration (ECG/Resp) Measurement

Description

The Measurement Server has a three-channel electrocardiogram and respiration measurement. It is designed to be used with adult, neonatal, or pediatric patients in ICU and OR environments.

Measurements

The ECG/Resp measurement produces continuous real-time waves for both cardiac and pulmonary activity. It also generates numerics for the average heart rate (HR), derived from the ECG, and for the respiration rate (RR).

You can use either standard or EASI lead placements with the M3046A Release E together with the M3001A. Using a standard 5-electrode set in EASI lead placement you can monitor three out of 12 standard ECG leads simultaneously and continuously at the bedside. EASI-derived 12-lead ECGs and their measurements are approximations to conventional 12-lead ECGs. As the 12-lead ECG derived with EASI is not exactly identical to the 12-lead conventional ECG obtained from an electrocardiograph, it should not be used for diagnostic interpretations.

Respiratory monitoring is also possible with the EASI placement; respiration is measured between the I and A electrodes.

ECG/Resp Features

This illustration shows the user controls and connectors for the ECG/Resp.

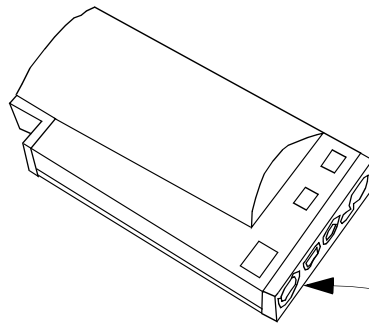

This standard 12-pin connector will accept either a 3-lead or a 5-lead ECG cable.

Features of the ECG/Resp measurements are described in the following paragraphs.

ECG Modes

The QRS complexes are detected automatically.

In non-paced mode, no pace pulses are expected and no pace pulse rejection occurs. In paced mode, pace pulses of channel 1 and 2 are annotated with a small dash on the screen.

Resp Modes

In auto mode, the Monitor measures respiration and adjusts the detection level automatically. In manual mode, the user sets the detection level for measuring respiration.

Safety

To ensure the safety of the patient, the patient-applied parts are isolated from ground by optical isolators and a transformer. The circuit is also encapsulated in plastic.

Block Diagram of the ECG/Resp

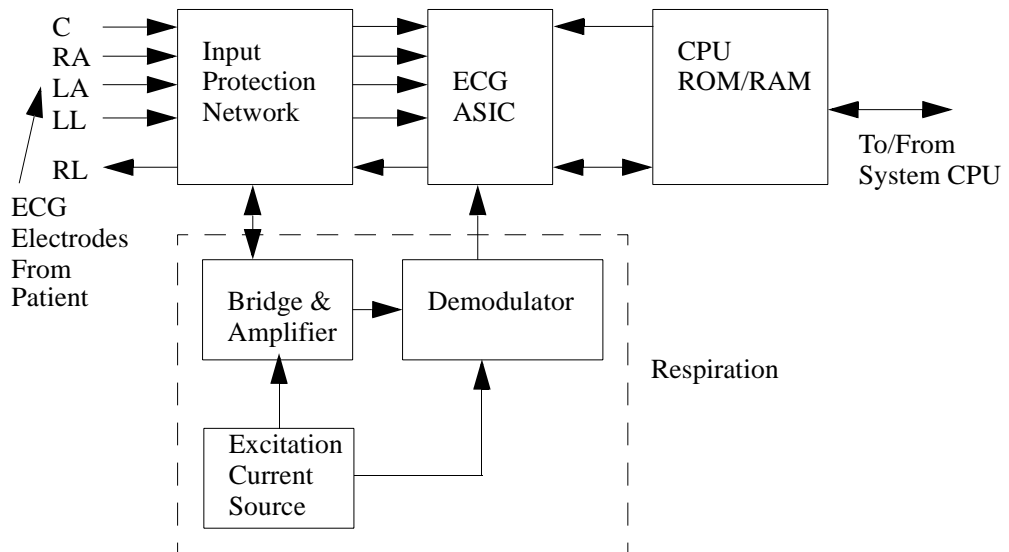

Theory of Operation

As ECG and Resp signals pass from the patient to the Monitor, they progress through stages corresponding to the logical sections of the circuit, as shown in the block diagram. Circuit-related faults can generally be isolated to one of the stages.

Transducer

Signals are received through patient electrodes and lead cables via the input connector.

Input Protection Network

The Input Protection Network and ESU filter eliminate extraneous signals. This protects the rest of the circuitry from defibrillator voltages, high frequency interference signals, and electrostatic discharges.

ECG ASIC

The signals are processed by the ECG Application-Specific Integrated Circuit (ECG ASIC) which has an input amplifier with a fixed gain for each of the four electrodes. They are then passed to a digital-to-analog converter (D/A Converter) for offset compensation and then to an analog-to-digital converter (A/D Converter). The input/output logic (which is controlled

from the CPU) controls the analog-to-digital conversion and reads out the digitized ECG data. The CPU communicates with the ECG ASIC via a built-in serial link.

To prevent interference from the 50/60Hz power line, the common mode signal is used to drive the right leg (RL) drive amplifier. The output from the amplifier is then returned to the patient via the RL electrode.

Excitation Current Source

The excitation current source feeds a small current into the right arm and left leg electrodes. This results in a voltage drop between the right arm and left leg which is proportional to the thorax impedance.

Bridge & Amplifier

The bridge subtracts an offset from the voltage between right arm and left leg. The amplifier amplifies the remaining signal.

The Central Processing Unit (CPU)

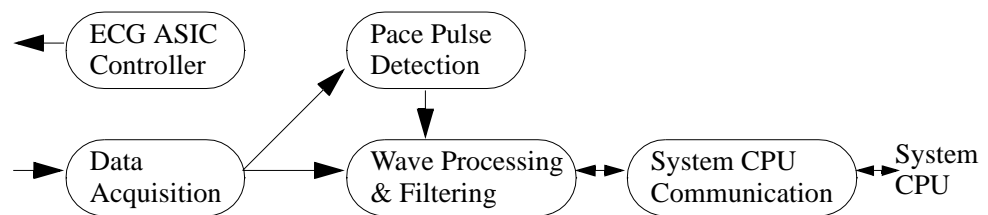

The CPU performs the following functions:

- **Controls the ECG ASIC, and stores ASIC specific calibration and error log data.** This initializes the intended ASIC configurations such as gain, A/D sampling rate, and DAC operation.
- **Acquires the digitized ECG and Resp signals.** Digitized ECG signals are used to calculate 3 ECG leads which are then passed on to the Pace Pulse detecting software, and the wave processing and filtering software.
- **Performs ECG wave filtering.** The waves are digitally filtered and scaled then passed to the software that communicates with the system CPU.
- **Performs pace pulse detection.** A digital high-pass filter acts as a slope detector for the received ECG waves. The output of the slope detector is fed into two comparators comparing the signal to a positive and negative threshold. The output of the comparators indicate the absence or presence of a pace pulse. The threshold of the comparators is moving and adapts itself to the amount of noise present in the ECG wave. Detected pace pulses are communicated to the wave processing and filtering software.
- **Communicates with the system CPU.** Communication is via a serial, bi-directional data link. The ECG/Resp CPU sends the following data to the system CPU:
 - 3 ECG waves,

- A respiration wave,
- Pace pulse data,
- INOP messages, and
- status messages.

The ECG/Resp CPU receives control messages from the system CPU.

ECG Software on the System CPU

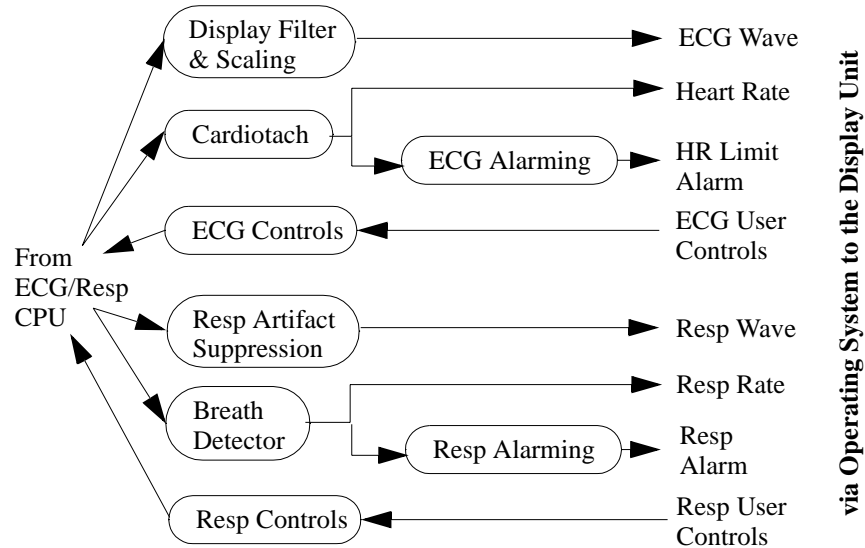

• **Display Filter and Scaling**

This software receives the raw ECG wave with pace pulse information from the ECG/Resp CPU. The pace pulse spikes are removed from the ECG before filtering, and re-inserted after filtering with their original shape (the filtering would distort them otherwise). Software filters remove line frequency (50/60Hz), high frequency noise, artifacts and baseline wander.

The waves are scaled automatically or manually as set by the user.

The defibrillator marker is superimposed on the ECG wave to be displayed.

ECG waves are communicated to the display unit via the operating system.

• **Cardiotach**

This software derives the averaged value of the heart rate. Pace pulses and undershoots are removed from the signal. The multi-channel QRS detector generates beat identification tags for the cardiotach. The detection algorithm weights noisy ECG channels less than channels with clear signals. The cardiotach measures the time between two detected QRS complexes and calculates a beat to beat and averaged heart rate. The heart rate is communicated to the ECG Alarming software, and to the display unit via the operating system.

- **ECG Alarming**

This software receives the averaged heart rate from the cardiotech software and derives alarms by comparing this rate against the limits and the asystole condition. Heart rate alarms are communicated to the display unit via the operating system.

- **ECG Controls**

This software handles:

- selection of ECG leads
- setting of heart rate alarm limits
- selection of ECG display filter characteristics

- **Respiration Artifact Suppression**

This software receives the respiration and ECG waves from the ECG/Resp CPU. A software filter removes any potential ECG overlay from the respiration wave. The filtered respiration waveform is communicated to the display unit via the operating system.

- **Breath Detector**

This software detects the respiration rate using a trigger threshold that is dynamically adjusted according to the amplitude of the wave. The time between breaths is measured and the respiration rate is calculated. This is communicated directly to the Resp alarming, and via the operating system to the display unit.

- **Resp Alarming**

This software receives the respiration rate from the breath detector and derives alarms by comparing this rate against the limits and the apnea condition. Respiration rate alarms are communicated to the display unit via the operating system.

- **Respiration Controls**

This software handles:

- setting of respiration rate alarm limits
- scaling of the display wave for the best fit for the display channel.

Non-invasive Blood Pressure (NBP) Measurement

Description

The Measurement Server has a non-invasive blood pressure measurement for the Monitor monitoring device. It is designed to be used with adult, paediatric, or neonatal patients, in ICU and OR environments.

Measurements

The measurement produces numerics for the systolic, diastolic, and mean blood pressure values. No wave is associated with this measurement.

Three different methods can be used to obtain the measurements, as follows:

- **Manual**—For each request, one measurement of systolic, diastolic, and mean pressures is taken.
- **Auto**—Repeated measurements of the three values are taken at timed intervals specified by the user.
- **Stat**—Measurements of the three values are taken immediately and repeatedly over a period of five minutes. This method uses a faster measurement procedure but produces a less accurate reading.

NBP Features

This illustration shows the user controls and connector for the measurements. The parts are described in the paragraphs following the illustration.

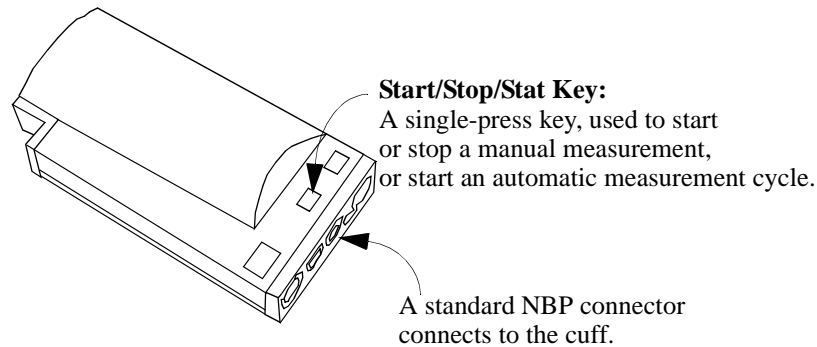

NBP Modes

The measurement offers adult, pediatric, and neonatal modes.

The following table lists the cuff inflation limits for each mode:

Mode	First Inflation	Subsequent Inflations, Above Systolic Pressure	Stat Mode
Adult	165	25	15
Pediatric	130	20	15
Neonatal	100	15	15

The following table lists the measurement ranges for each mode:

Mode	Systolic	Diastolic	Mean
Adult	30 - 270	10 - 245	20 - 255
Pediatric	30 - 180	10 - 150	20 - 160
Neonatal	30 - 130	10 - 100	20 - 120

Safety

The following table lists the maximum limits that ensure patient safety:

Mode	Maximum Measurement Time	Maximum Time/ Pressure	Over-pressure Maximum
Adult	180 seconds	180 seconds for pressure > 15 mmHg	300 mmHg for > 2 seconds
Pediatric	180 seconds	180 seconds for pressure > 15 mmHg	300 mmHg for > 2 seconds
Neonatal	90 seconds	90 seconds for pressure > 5 mmHg	150 mmHg for > 2 seconds

If any one of these safety limits is violated, an INOP is generated and the valve opens.

Block Diagram for NBP

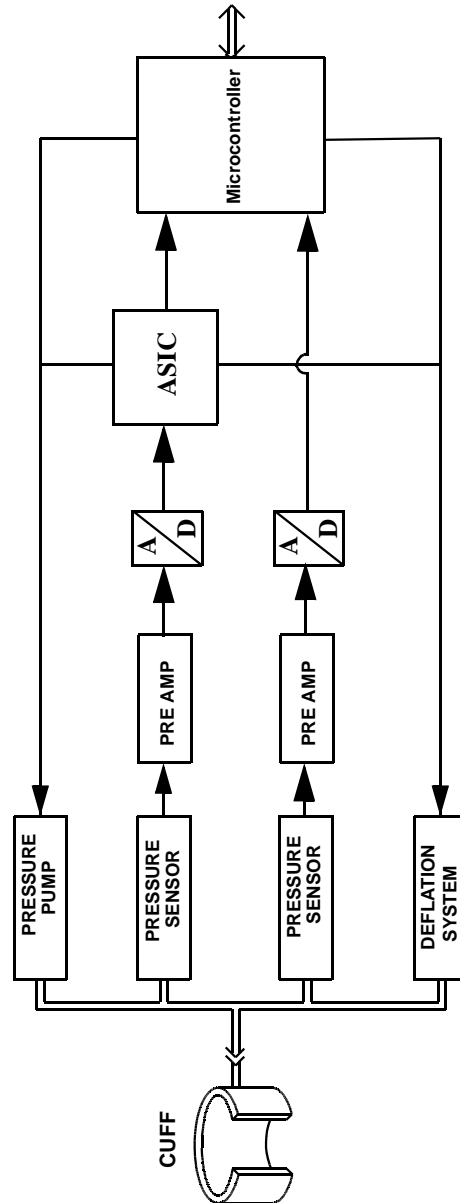

Components

The following components carry out the major signal processing functions within the

measurement.

Pressure Pump—Inflates the cuff to preset limits, once or repeatedly, depending on the measurement method used.

Pressure Sensor—Measures cuff pressure using solid-state technology.

Overpressure Safety System—Triggers alerts at given pressures and time limits, and deflates the cuff.

Bandpass Filter—Extracts arterial pressure oscillations from the cuff pressure.

Deflation System—Automatically deflates the cuff at steps of a given magnitude.

NBP Measurement Characteristic

See “Selecting NBP Measurement Characteristic” on page 87.

Theory of Operation

As NBP signals pass from the patient to the Monitor, they progress through stages corresponding to logical sections of the circuit, as shown in the block diagram. Circuit-related faults can generally be isolated to one of the stages.

- 1 Acquisition**—Signals from the patient are received by the pressure sensor through the cuff, which is connected to the circuit by a single tube. The cuff is inflated, deflated, and monitored by a pump, deflation system, and safety system controlled by a microprocessor.
 - a. Cuff Inflation**—During the initial cuff inflation, the cuff is inflated by the pressure pump to a set pressure which is determined by the patient size. Thereafter the cuff is inflated by the pressure pump to a cuff pressure above the patient’s systolic pressure. Depending on the measurement method used, inflation occurs once or repeatedly. When the cuff pressure is greater than the systolic pressure, the artery is occluded; the pressure sensor then detects only the cuff pressure.
 - b. Cuff Deflation**—Cuff pressure is automatically released by the deflation system in steps until the artery is only partially occluded. At that point, measurement and processing of arterial pressure oscillations begin and continue as the cuff pressure is progressively released.
- 2 Detection**—The arterial pressure oscillations are superimposed on the cuff pressure. They are extracted from the cuff pressure by a digital bandpass filter in the microcontroller.
- 3 Measurement**—As the cuff is deflated, the magnitude of the oscillations as a function of cuff pressure increases until the mean arterial pressure is reached. When cuff pressure falls below the mean arterial pressure, oscillation magnitude begins to decrease.

The systolic and diastolic blood pressure values are deduced from the oscillometric signal by extrapolation. Differences in the results with the standard stethoscope method can be expected. The NBP accuracy complies with AAMI SP-10.

Arterial Oxygen Saturation and Pleth (SpO₂/PLETH) Measurement

Description

The Measurement Server has a pulse, arterial oxygen saturation, and plethysmogram measurement.

Measurements

The measurement produces numerics for the arterial oxygen saturation value and the pulse rate, along with a real-time wave for the plethysmogram.

SpO₂/PLETH Features

This illustration shows the user controls and connector for the SpO₂/PLETH. The parts are described following the illustration below.

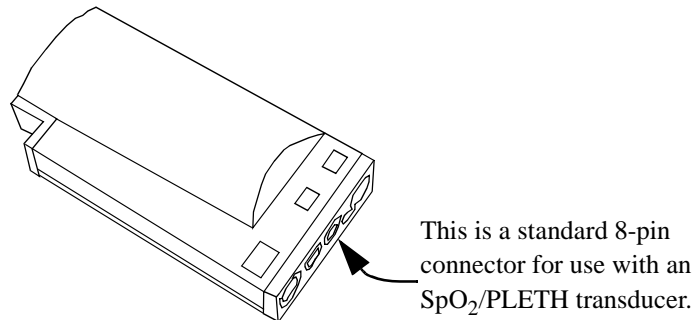

Safety

To ensure the safety of the patient, the patient-applied part is isolated from ground by opto-couplers and a transformer. The circuit is also encapsulated in plastic.

PLETH Wave

The circuit automatically and continuously adjusts the size of the wave, which represents the quality of the SpO₂ measurement signals. Manual wave adjustments in this mode are not possible. If the signal quality becomes weak, the wave becomes progressively smaller. If the signal degrades below an acceptable level, the wave becomes flat and an INOP alarm results. A poor signal may be caused by poor perfusion at the transducer site, or by the transducer; it is *not* related to low oxygen saturation.

This illustration contains an example of a typical wave in SpO₂.

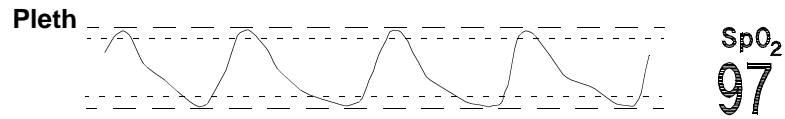

Block Diagram of the SpO₂/PLETH Circuit

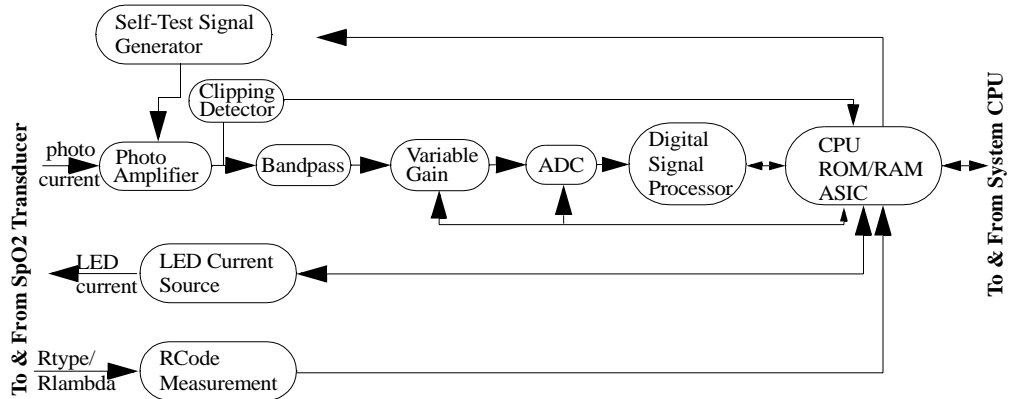

Theory of Operation

The signals progress through the circuit as follows:

LED Current Source

This generates the LED current from a constant voltage provided by the power supply. A bridge consisting of four transistors switches the LED current for driving the red and infrared LEDs. These switching transistors are controlled by the SpO₂ CPU.

Photo Amplifier

The photo amplifier is an active input current to voltage converter. The input signal is filtered by a low pass filter to eliminate higher frequencies generated, for example, by electro-surgery units. Then the input current from the photo diode of the sensor is converted to a voltage.

Clipping Detector

A comparator detects clipping of the photo-amplifier signal caused by, for example, ambient light. The clipping detection is connected directly to the SpO₂ CPU to generate an INOP if necessary.

Bandpass

The bandpass stage contains a bandpass filter for the modulated signals coming in from the photo-amplifier. This filters out noise outside a passband centred on the modulation frequency.

Variable Gain

This section amplifies the incoming signals. The gain is set by a digital to analog converter (DAC) which allows 512 gain settings.

Analog to Digital Converter (ADC)

This is a 12-bit converter. Oversampling is used to get the required resolution. To optimize the ADC input voltage, the variable gain adapts accordingly to the signal quality.

Digital Signal Processor (DSP)

The DSP demodulates and filters the signal from the ADC, and passes it on to the SpO₂ ASIC.

Self-Test Signal Generator

This generates a wave that is similar to a patient signal. It is processed through the complete circuitry starting at the photo amplifier stage. Just before the processing of the patient signal begins, the test signal is switched on to check correct functioning of the circuitry.

RCode Measurement Circuit

This circuit measures the coding resistor of the transducer, digitizes it, and sends it to the SpO₂ CPU.

Each transducer has coding resistors in the connector, so that it can be identified by this measurement.

CPU, ROM/RAM and ASIC

The **ASIC** is the interface between the digital signal processor and the SpO₂ CPU. The ASIC also acts as an interface to the ADC and contains all the frequency generators for the ADC clock, the sampling frequency and the modulation frequency. The main clock for the ASIC is provided by a Pierce oscillator circuit external to the chip.

The **CPU** gets the processed SpO₂ signal from the ASIC, and controls the LED current source, the RCode measurement, the variable gain stage, the clipping detection, the power supply, and the Self-Test circuit. The CPU also detects INOP and error information and handles communication with the system CPU.

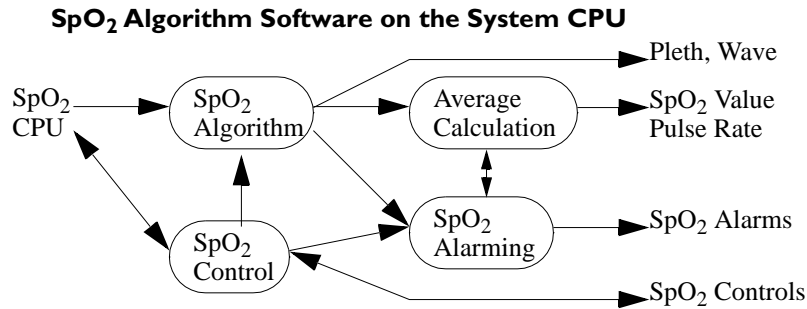

The **SpO₂ Algorithm** receives the demodulated and filtered red and infrared signals, and the transducer coding information from the SpO₂ measurement frontend. The red and infra-red wave is transformed into the frequency domain. An adaptive signal analysis of the frequency information eliminates artifact and noise from the patient signal that is then used to calculate the SpO₂ and Pulse numeric values.

The SpO₂ algorithm also detects non-pulsatile or noisy signals, and generates the appropriate INOPs.

The wave is communicated to the Monitor (via the operating system), the SpO₂ and pulse rate are communicated to the average calculation software, and INOPs are communicated to the alarming software.

- The **Average Calculation** software receives the SpO₂ value for each beat from the SpO₂ algorithm, and calculates the average over the time interval configured by the user. This value is communicated to the Monitor via the operating system, and to the Alarming software.
- The **SpO₂ Alarming** software gets the average SpO₂ value from the average calculation software and compares it against the limits set by the user. This software also gets INOP messages from the SpO₂ algorithm software. Alarms are communicated to the Monitor via the operating software.
- The **SpO₂ Controller** software receives the red and infrared signals, the transducer coding information, the INOP and error messages and the status information from the SpO₂ CPU. It receives the operating controls and the user settings from the Monitor. The user settings are stored in non-volatile memory.

Temperature and Invasive Blood Pressure (Temp/Press) measurement

Description

The Measurement Server has a measurement channel which can measure invasive pressure or temperature.

Measurements

The measurement produces a numeric for temperature; or a real-time pressure wave, together with the pulse rate and numeric readings for the systolic, diastolic, and mean blood pressure values.

Temp/Press Features

This illustration shows the user controls and connector for the Temp/Press.

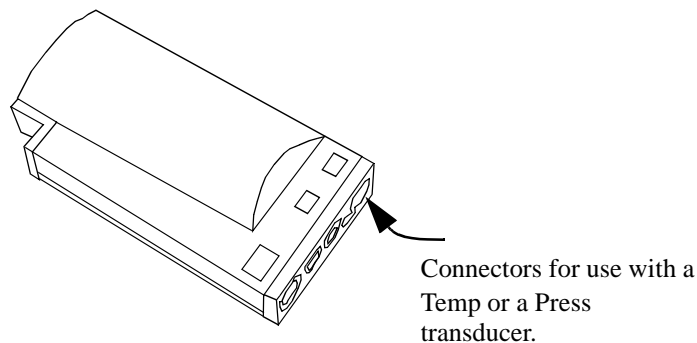

Press Wave

Blood pressure is depicted as a pressure wave with the numerics for systolic, diastolic, and mean pressure values. The blood pressure shows the cycles of contraction and release within the heart and the resultant pressure that is generated to move the blood through the vessels.

This illustration is an example of a typical invasive pressure wave.

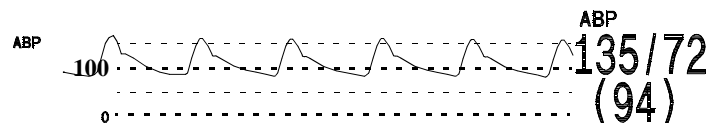

Temp Mode

Measurement Range: -1 to 45°C (30 to 113°F)

Safety

To ensure the safety of the patient, the patient-applied part is isolated from ground by opto-couplers and a transformer. The circuit is also encapsulated in plastic.

Block Diagram

This illustration shows the block diagram of the Temp/Press circuit.

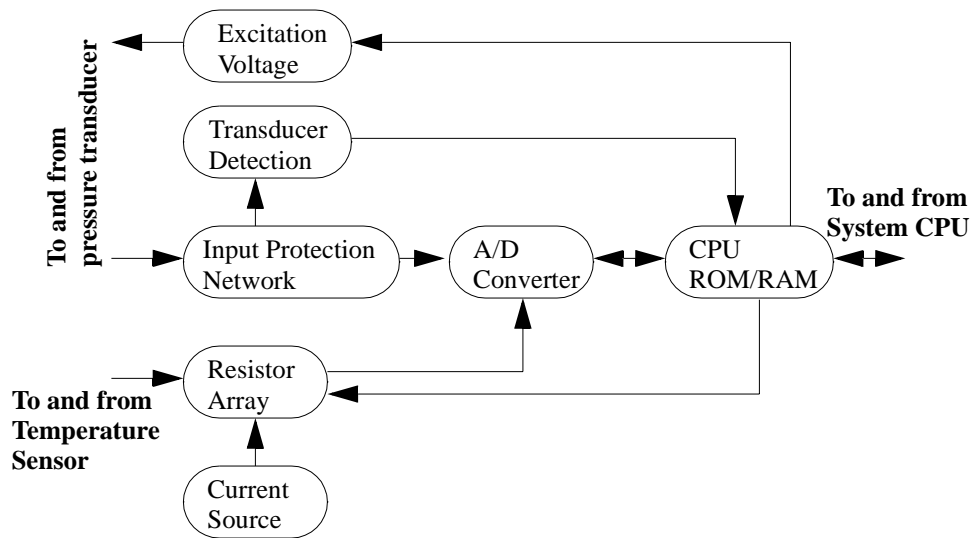

Theory of Operation

The signals progress through the circuit as follows:

Excitation Voltage

This supplies 5V_{DC} to a connected transducer. If a short circuit is detected by this circuit, the CPU switches the voltage source off (to reduce power consumption).

Input Protection Network

This provides protection for the rest of the circuit against defibrillator voltage, electrostatic discharge, and any electromagnetic interference. The signal is passed on to the analog to digital converter, and to the transducer detection circuit.

Transducer Detection

The transducer being used can be determined by recognising the coding in the connector. This is done by the transducer detection circuitry. A window comparator checks the input voltages provided by the transducer against specified limits.

Current Source

The current source generates a constant current for the resistor array that is used to measure the temperature.

Resistor Array

The constant current is fed through four resistors in series: A test resistor, the externally connected temperature probe, a gain calibration resistor, and an offset resistor. The voltage drop across each resistor is sequentially measured and digitized. The CPU controls the measurement of the different voltage drops and the ADC.

Analog to Digital Converter (ADC)

The ADC receives the pressure signal from the Input Protection Network and the temperature signal from the Resistor Array. The ADC amplifies, filters, and digitizes the received pressure or temperature signal. The CPU controls the A/D conversion and accesses the digitized data for further processing.

Central Processing Unit (CPU)

The CPU controls the ADC and receives the digitized pressure or temperature data from the ADC. The CPU calculates the temperature values and scales the raw pressure waveform using stored pressure calibration data. The CPU stores pressure calibration data and user settings into a non-volatile read/write storage device. The scaled pressure waveform and temperature data are communicated to the System CPU via a serial interface. The CPU receives calibration data and user settings from the System CPU.

Temperature and Invasive Pressure Software

The CPU contains software that performs:

- communication with the System CPU
- data acquisition of the invasive pressure signal or temperature
- control of the A/D converter
- pressure wave and temperature numeric filtering
- switching between temperature and pressure measurement depending on the connected transducer
- INOP and error detection and self-tests

The CPU receives control information from the System CPU and transmits the pressure wave or a temperature numeric, INOPs and error and status messages to the System CPU.

The CPU software functionality is structured into the following modules (see block diagram):

- System CPU communication
- ADC controller and data acquisition
- Wave/numeric processing and filtering
- Pressure/temperature mode detection

Block Diagram of the Temp/Press Software

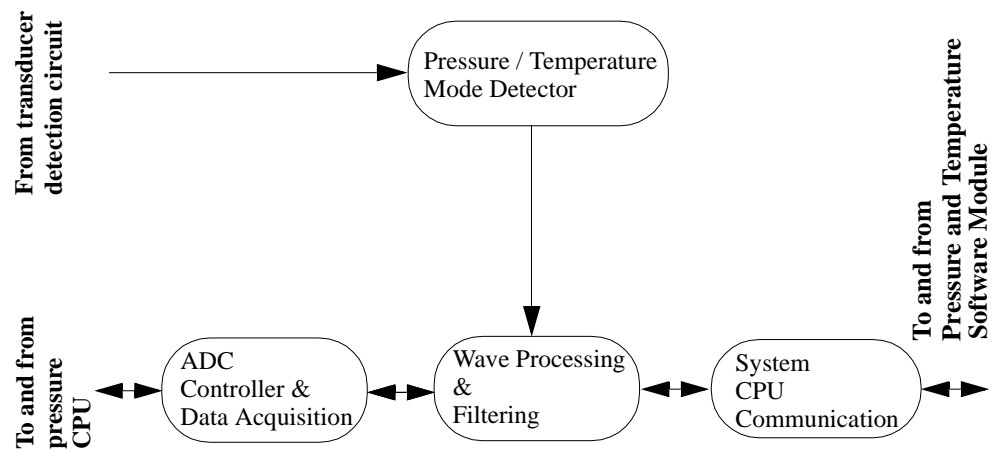

System CPU Communication

The pressure/temperature measurement section of the CPU contains a serial bi-directional data communication link to the pressure/temperature modules of the system CPU.

The following data is transmitted to the system CPU:

- Pressure wave
- Temperature numeric
- INOP and error messages
- Status messages

The following data is received from the CPU:

- Control messages

All messages in both directions are secured by checksums.

ADC Controller and Data Acquisition

The data exchange between the A/D converter and the CPU is based on a serial communication link. The calibration information is periodically refreshed to ensure proper operation of the converter. The converter generates an interrupt each time new data is

available. This forces the CPU to retrieve the data and to calculate the scaled pressure waveform of temperature value.

Wave Processing and Filtering

Pressure measurement: Data from the A/D converter is sent to a single-pole digital filter which generates the specified frequency response. Additionally, the transducer zero value is subtracted from the signal.

Temperature measurement: This is referenced against a high-precision calibration resistor. Each temperature value consists of 16 averaged samples and the test resistor verifies the linearity of the measurement. With an offset resistor all offsets are eliminated.

Pressure & Temperature Mode Detector

The CPU switches between two different A/D converter controls and wave processing algorithms depending on the connected transducer: Pressure or Temperature. To recognize the presence of a pressure transducer, a coding within the transducer is checked. To recognize the presence of a temperature transducer, the transducer's resistance is measured and must be within specified limits. This is only done when no pressure transducer is present.

Invasive Pressure Software Module

The Invasive Blood Pressure Module derives three numerical pressure values (systolic, diastolic, and mean), a blood pressure waveform and a pulse rate. The module is designed to be used with DC pressure transducers ($5 \mu\text{V/V/mmHg}$) only. Alarm limits can be set for pressure and pulse values. Alarm messages are issued if the calculated values are outside the set range or outside the measurement range.

Block diagram of the Invasive Pressure Software Module

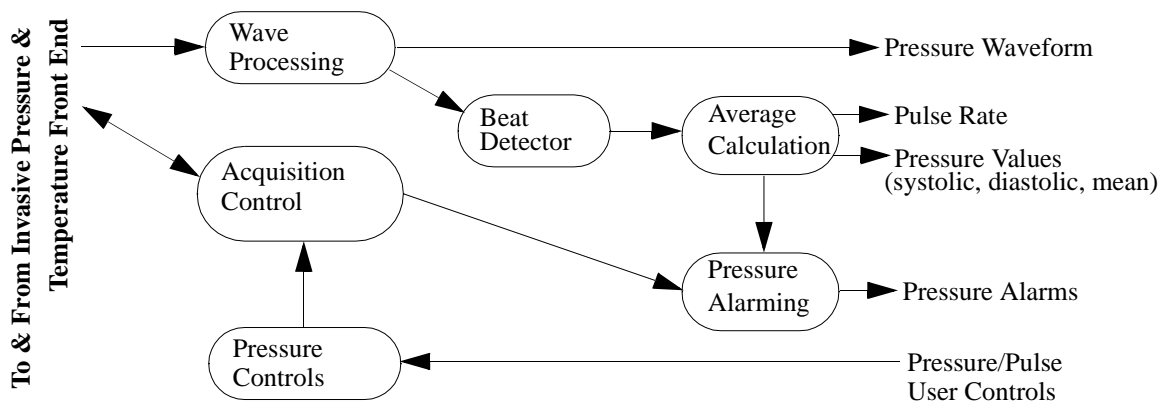

Signal Acquisition

This module is responsible for the A/D conversion of the analog signal from the pressure transducer. The Signal Acquisition module provides a raw pressure waveform to the Wave Processing module. A special test mode and a zero procedure can be enabled and performed on request. The module also performs various self-tests and consistency checks to ensure proper operation and reports errors and failures to the Acquisition Module.

Acquisition Control

This component receives the hardware-related information from the signal acquisition component. This includes status data and error/failure reports.

Wave Processing

The raw waveform from the Signal Acquisition module is filtered. Gain and offset values of the raw waveform are corrected so that the wave sample-values represent absolute values according to the selected scale.

Beat Detector

The Beat Detector determines the position of a beat in the pulsatile pressure waveform. This information is used to calculate systolic, diastolic, and mean beat pressure values and to calculate pulse rate.

Average Calculation

The calculated beat pressure and pulse values are averaged and converted to the user-selected measurement unit (mmHg or kPa).

Pressure Alarming

This component generates the appropriate alarm when the averaged pressure or pulse values exceed the user-selected alarm limits. Technical alarms are generated when the Acquisition Control component detects errors or failures.

Pressure/Pulse User Controls

This component controls the user-selected settings:

- Change the pressure units (mmHg/kPa)
- Change the pressure and pulse-rate alarm limits
- Select the input filter
- Start zero and calibration procedures
- Select the scale of the displayed wave
- Select the displayed pressure label

Temperature Software Module

The Temperature module derives a temperature value from a YSI series 400 thermistor temperature probe. The temperature label is selectable and temperature-related alarm limits can be set. An alarm message is displayed when the measured temperature is outside the set range or outside the measurement range.

Block diagram of the Temperature Software Module

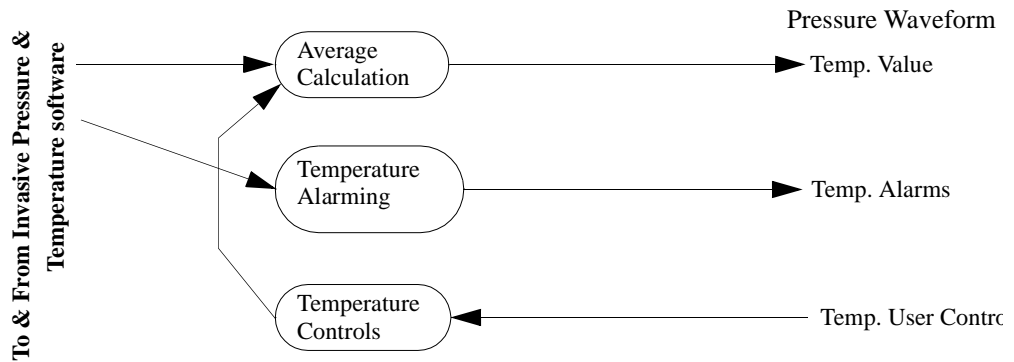

Signal Acquisition

This module is responsible for the A/D conversion of the analog signal from the temperature transducer. The Signal Acquisition module provides a raw temperature value to the Average Calculation module. The module also performs various self-tests and consistency checks to ensure proper operation and reports errors and failures to the Alarming Module.

Average Calculation

This component averages the raw measured temperature values over an interval of 1 second. The averaged values are converted to the user-selected unit.

Temperature Alarming

This component generates high/low alarms if an alarm limit is exceeded. Additionally, a technical alarm is generated if no temperature can be measured.

Temperature User Controls

This component controls the user-selected settings:

- Set temperature alarm limits
- Select the temperature measurement units

Section 3 - Measurement Server Extensions Description and Features

The Measurement Server Extensions (M3015A and M3016A) are flexible patient measurement units which partner with the Measurement Server to form the base for a variety of systems that enable easy customization to a hospital's requirements. Extensions, as convenient parts, expand on the important patient measurements provided by the Measurement Server.

Used with the Measurement Server, the Measurement Server Extension is designed to Monitor patients in most critical and acute patient care areas of the hospital. For bedside use, the Server and Extension are most commonly seen mounted on a Monitor. The Server and an Extension can also be mounted on a bed or a roller stand.

M3015A Measurement Server Extension

The Measurement Server Extension for sidestream CO₂ measurement (M3015A) includes:

- Measurements of sidestream CO₂ , and Press/Temp*
- Signal and alarm processing

* (M3015A #C06 only.)

M3016A Measurement Server Extension

The Measurement Server Extension for mainstream CO₂ measurement (M3016A) includes:

- Measurements of mainstream CO₂** and Press/Temp
- Signal and alarm processing

** (M3016A #A01 only.)

Features

The Measurement Server Extensions have the following general features:

Data Management

The combination of the Measurement Server and the Measurement Server Extension features also Patient Data Management for CO₂ and the second Pressure/Temp. This consists of continuous 4-hour storage of patient-related measurement information. This allows you to do the following:

- Manage patient information.
- View patient data in graphs or tables via the Monitor.
- Print patient information reports to a local printer via the Monitor.
- Transfer data between Monitors.

Settings Transfer

The combination of the Measurement Server and the Measurement Server Extension can be transported from one Monitor to another and still keep its measurement settings. The settings (such as alarm limits) are stored in the Measurement Server. This behaviour permits fast and easy transport

Alarms Reset

The Measurement Server Extension responds to the Silence/Reset key on the Measurement Server which allows you to silence alarm tones, while retaining visual alarm messages (depending on your Monitor's configuration).

Server-to-Monitor Link Bar

A double connector version of the Server-to-Monitor link bar allows quick and easy connection to a Monitor on one side and a Measurement Server on the other. This allows the Monitor to show waves and alarms of interest from both the Measurement Server and the Measurement Server Extension.

The interface subsystem consists of the physical interface to the Monitor and the Measurement Server and controlling software.

Digitized patient information transmitted over the link bar may be waves (e.g. for ECG, pressure, respiration, etc.); numeric information (for heart rate/pulse, pressure values, and respiration rate); or alert information (for alarms and assorted status information).

M3015A Measurement Server Extension Theory of Operation

The application-specific software for the second pressure/temp and CO₂ runs on the main CPU in the Measurement Server (see "Measurement Server Theory of Operation" on page 21). The pressure/temperature and the CO₂ frontends communicate the pre-processed physiological data via the Frontend Link Protocol to the application-specific software on the main CPU of the Measurement Server.

The Temp/Press features available on the Extension are identical to those available on the Server. The Temp/Press selections specific to the Extension are T2 and P2.

If you press the Zero key on the Server, all invasive pressure measurements in use are zeroed. To set independent zero and labels for P2, however, go into the Setup window on the Monitor.

If two temperatures are measured (one with the Server and one with the Extension), the differential temperature (Delta Temp) is calculated by the Server.

For more information, see the section "Temperature and Invasive Blood Pressure (Temp/Press) measurement" on page 37.

Functional Description of the M3015A Measurement Server Extension Hardware

The Extension receives information signals (such as Temp/Press) and a sidestream CO₂ sample from the patient then transmits the data through the Server to the Monitor via the Server-to-Monitor link bar. See the “Functional Description of the Measurement Server Hardware” on page 22 for a description of the normal processing of measurement data.

The sidestream CO₂ Extension is always used with a Server. To function correctly, both the Server and the Extension must have compatible software revisions.

WARNING

Never use a Measurement Extension with a Measurement Server which contains Release A software (A.XX.XX). Since the software required to process data from the Extension is absent, the additional measurements will not be displayed. To view the software revision, press the Setup key and select Revisions.

Pairing the Server with the Extension allows for the following:

- Measurement of both temperature and invasive blood pressure for the same patient.
- Two temperature measurements for the same patient including a Delta Temp calculation feature.
- Two invasive blood pressure measurements for the same patient.

For more information, see the section “Temperature and Invasive Blood Pressure (Temp/Press) measurement” on page 37.

Hardware Block Diagram

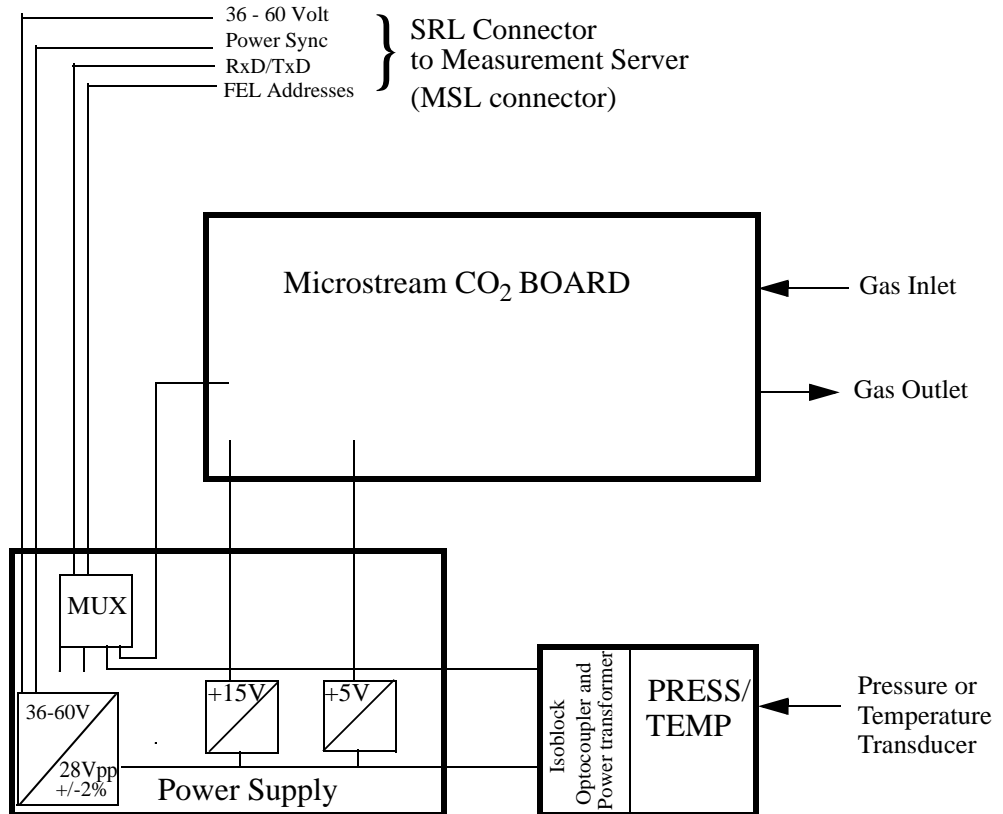

Main Functional Areas

- Microstream CO₂ Board - consisting of an 80C552 Controller, the memory system (Flash ROM, RAM, PLA, etc.), the Flow system (FilterLine recognition system, Inlet, solenoid valve), Measurement Cell (Exciter, IR Source, Detectors and Temp Sensor) and an analog section with ADC.
- DC/DC Converter Board -connecting to the Floating/Non-floating isolation area on the Front-End Board. Consisting also of a multiplexer for Front-End Link communication to the Measurement Server.
- PRESS/TEMP Front-End Board - consisting of the PRESS/TEMP Front-End and the Floating/Non-floating Isolation area, all feeding signals to the DC/DC Board.

Sidestream CO₂ Measurement

Description

The M3015A Measurement Server Extension has a sidestream carbon dioxide respiratory gas measurement for the Monitor monitoring device. It is designed to be used with the M3000A/M3001A Measurement Server for adult, pediatric, or neonatal patients, in a hospital environment and during patient transport in and outside hospitals by clinical users. The patients can be intubated or non-intubated.

CO₂ respiratory gas measurements indicate the efficiency of the transfer of oxygen from alveolar air into pulmonary capillary blood and the elimination of carbon dioxide from pulmonary capillary blood and its transfer into alveolar air.

CO₂ respiratory gas measurements are evaluated as gas passes through the airway adapter on the patient's intubation system. CO₂ respiratory gas measurements are an indication of the patient's overall respiratory status.

Blood Gas concepts important to this section are:

- **Airway Respiration Rate (AwRR)**—The number of inspirations and expirations per minute.
- **End Tidal CO₂ (EtCO₂)**—The highest partial pressure of CO₂ measured during one expiration.
- **Inspired Minimum CO₂ (ImCO₂)**—The lowest partial pressure of CO₂ during inspiration.
- **Instantaneous CO₂**—The CO₂ measurement at any instant.
- **Ventilation**—The movement of air in and out of the lungs by inspiration and expiration.

Measurements

The sidestream CO₂ measurement produces respiratory CO₂ gas readings in a real-time CO₂ waveform together with numerics for End-tidal CO₂ (EtCO₂), Airway Respiration Rate (AwRR), and Inspired Minimum Carbon Dioxide (ImCO₂).

Factors affecting accurate measurement of sidestream CO₂ respiratory gas are as follows:

- Proper connection between the Extension and the patient's respiratory system.
- Temperature of the patient's breath.
- Amount of water vapour in the patient's breath.
- Barometric pressure at the site of measurement acquisition.
- Other gases, most notably N₂O and O₂, in the gas mixture.

The EtCO₂ (End Tidal Carbon Dioxide) measurement for Carbon Dioxide uses a technique based on the absorption of infrared radiation by certain gases.

Infrared light is absorbed by CO₂. The amount of absorption varies according to the CO₂ concentration in the gas mixture. By using an infrared detector to measure the absorption, the CO₂ concentration in a gas can be derived.

Sidestream CO₂ Features

This illustration shows the user controls on the Server and the connector for appropriate tubing for the sidestream CO₂ measurement on the Extension.

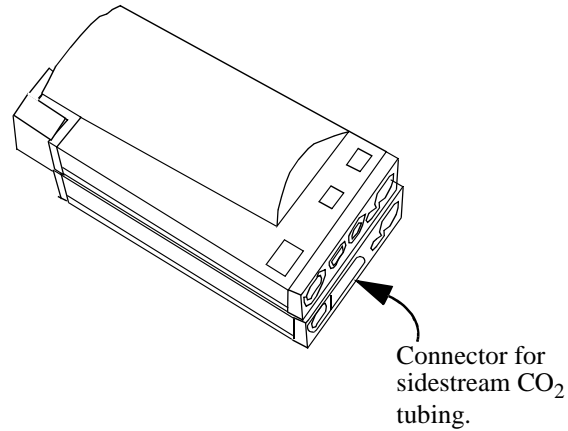

Sidestream CO₂ Wave

The two calibration marks are located at 10% and 60% of wave channel height. The lower calibration mark is labelled 0 mmHg (0.0 kPa) on all scales. The upper one is adjustable from 20 mmHg (2kPa) to 100 mmHg (13 kPa) in steps of 10 mmHg (1kPa).

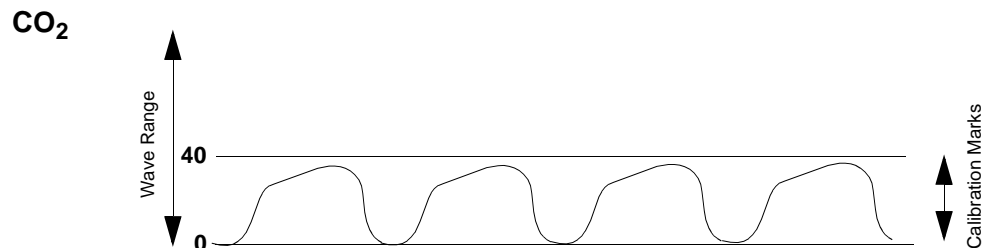

Measurement Mode

In the measurement mode, the Extension continuously measures CO₂ concentration, calculates medical parameters and exchanges information with the Server via FELP.

- **N₂O Correction**—This can be turned on or off. If N₂O correction is off, only oxygen correction to CO₂ is made. In this case, it is assumed that the gas mixture consists mainly of O₂ and N₂ (respiratory intensive care unit conditions).

If N₂O correction is on, oxygen and N₂O correction to the CO₂ value is made. In this case, it is assumed that the gas mixture consists mainly of O₂ and N₂O (operating room conditions).

N₂O correction is required only on M3015A Measurement Server Extensions with CO₂ Data Acquisition hardware revision A.01.09 or lower.

- **N₂O Correction**—This can be turned on or off. If N₂O correction is off, only oxygen correction to CO₂ is made. In this case, it is assumed that the gas mixture consists mainly of O₂ and N₂ (respiratory intensive care unit conditions).

If N₂O correction is on, oxygen and N₂O correction to the CO₂ value is made. In this case, it is assumed that the gas mixture consists mainly of O₂ and N₂O (operating room conditions).

- **O₂ Correction**— There is a fixed correction of 45% O₂.
- **Humidity Correction**—This correction is selectable between Body Temperature Pressure Saturated (BTPS) and Standard Pressure Temperature Dry (STPD). The Extension measures STPD and uses this correction formula:
$$\text{BTPS} = 0.94 \times \text{STPD}$$

- **Max Hold**—There are three possible selections:

- . **Off**—The ETCO₂ and IMCO₂ numerics display the breath-to-breath value.
- . **10 seconds**—The ETCO₂ and IMCO₂ numerics display the highest/lowest value within a moving window over a 10-second period.
- . **20 seconds**—The ETCO₂ and IMCO₂ numerics display the highest/lowest value within a moving window over a 20-second period.

Block Diagram of the Sidestream CO₂ measurement

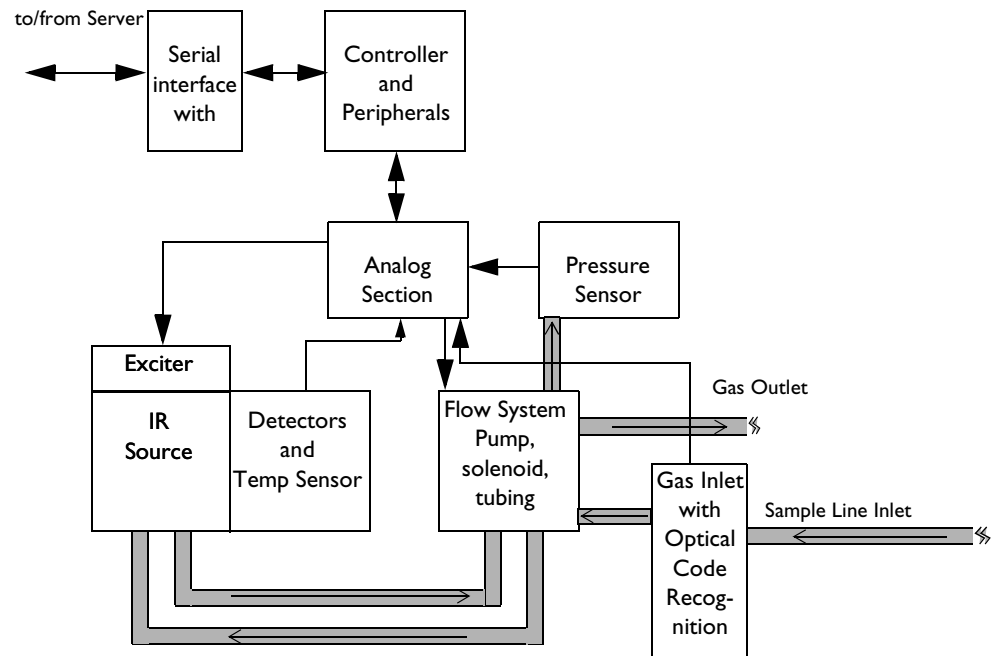

Theory of Operation for M3015A Sidestream CO₂

Sidestream CO₂ is measured based on non-dispersive infrared absorption of breathing gas samples. Signals progress through the circuit as follows:

Flow System

The flow system circulates the sidestream gas sample and pumps out waste gas.

Temperature Sensor

The temperature of the detector is measured and used to compensate temperature drift of the CO₂ reading. Signals from the temperature sensor in the detector are amplified and then passed through an Analog-to-Digital converter.

Exciter and Infrared Source

The exciter generates a high frequency, high voltage signal to ignite the infra-red source and to generate the infrared radiation needed to measure the CO₂ concentration in the measurement cell.

Detectors

The detectors are used to detect the reference signal (the signal which comes directly from the IR source) and the main signal (the signal which passes through the sample cell).

Pressure Sensor

The pressure sensor is used to measure the ambient pressure during the auto zero process and to measure the pressure in the measurement cell during measurement mode.

Analog Section

The analog section amplifies and digitizes the main, reference, pressure and temperature signals.

Controller and Peripherals

The controller reads the digitized values from the analog section and calculates the CO₂ wave and numerics based on the measured main, reference, pressure and temperature signals. The controller also controls the CO₂ frontend based on the control information received from the Measurement Server, the Optical Code Recognition and the measured cell pressure.

Gas Inlet with Optical Code Recognition

The gas inlet allows the connection of Microstream FilterLines. The Microstream FilterLines are detected by the Optical Code Recognition.

Serial Interface with FELP

The Serial Interface and Frontend Link Protocol (FELP) provide the communication interface between the CO₂ frontend and the CO₂ application software module running on the main CPU of the Measurement Server.

M3016A Measurement Server Extension Theory of Operation

The application-specific software for the second pressure/temp and CO₂ runs on the main CPU in the Measurement Server (see “Measurement Server Theory of Operation” on page 21). The pressure/temperature and the CO₂ frontends communicate the pre-processed physiological data via the Frontend Link Protocol to the application-specific software on the main CPU of the Measurement Server.

The Temp/Press features available on the Extension are identical to those available on the Server. The Temp/Press selections specific to the Extension are T2 and P2.

If you press the Zero key on the Server all invasive pressure channels in use are zeroed. To set independent zero and labels for P2, however, use the softkeys on the Monitor.

If two temperatures are measured (one with the Server and one with the Extension), the differential temperature (Delta Temp) is calculated by the Server.

For more information, see the section “Temperature and Invasive Blood Pressure (Temp/Press) measurement” on page 37.

Functional Description of the M3016A Measurement Server Extension Hardware

The Extension receives information signals (such as Temp/Press and mainstream CO₂) from the patient then transmits the data through the Server to the Monitor via the Server-to-Monitor link bar. See the “Functional Description of the Measurement Server Hardware” on page 22 for a description of the normal processing of measurement data.

The mainstream CO₂ Extension is always used with a Server. To function correctly, both the Server and the Extension must have compatible software revisions.

WARNING

Never use a Measurement Extension with a Measurement Server which contains Release A software (A.XX.XX). Since the software required to process data from the Extension is absent, the additional measurements will not be displayed. To view the software revision, press the Setup key and select Revisions.

Pairing the Server with the Extension allows for the following:

- Measurement of both temperature and invasive blood pressure for the same patient.
- Two temperature measurements for the same patient including a Delta Temp calculation feature.
- Two invasive blood pressure measurements for the same patient.

For more information, see the section “Temperature and Invasive Blood Pressure (Temp/Press) measurement” on page 37.

Hardware Block Diagram

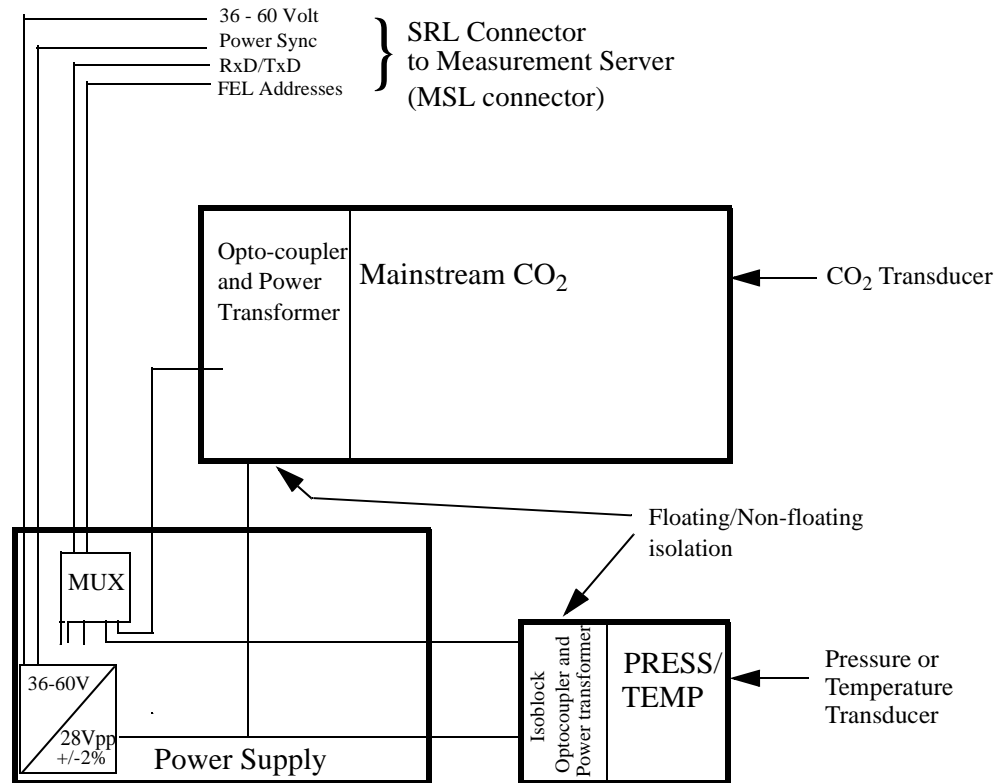

Main Functional Areas

- Front-End Board - consisting of the CO₂ Front-End, PRESS/TEMP Front-End and the Floating/Non-floating isolation area all feeding signals to the DC/DC Converter Board.
- DC/DC Converter Board - connecting to the Floating/Non-floating isolation area on the Front-End Board. Consisting also of a multiplexer for Front-End Link communication to the Measurement Server.

Mainstream CO₂ Measurement

Description

The M3016A Measurement Server Extension has a mainstream carbon dioxide respiratory gas measurement for the Monitor monitoring device. It is designed to be used with the M3000A Measurement Server for adult, pediatric, or neonatal patients, in a hospital environment and during patient transport in and outside hospitals by clinical users.

CO₂ respiratory gas measurements indicate the efficiency of the transfer of oxygen from alveolar air into pulmonary capillary blood and the elimination of carbon dioxide from pulmonary capillary blood and its transfer into alveolar air.

CO₂ respiratory gas measurements are evaluated as gas passes through the airway adapter on the patient's intubation system. CO₂ respiratory gas measurements are an indication of the patient's overall respiratory status.

Blood Gas concepts important to this section are:

- **Airway Respiration Rate (AwRR)**—The number of inspirations and expirations per minute.
- **End Tidal CO₂ (EtCO₂)**—Highest partial pressure of CO₂ measured during one expiration.
- **Inspired Minimum CO₂ (ImCO₂)**—Lowest partial pressure of CO₂ during inspiration.
- **Instantaneous CO₂**—The CO₂ measurement at any instant.
- **Ventilation**—The movement of air in and out of the lungs by inspiration and expiration.

Measurements

The mainstream CO₂ measurement produces respiratory CO₂ gas readings in a real-time CO₂ waveform together with numerics for End Tidal CO₂ (EtCO₂), Airway Respiration Rate (AwRR), and Inspired Minimum Carbon Dioxide (ImCO₂).

Factors affecting accurate measurement of mainstream CO₂ respiratory gas are as follows:

- Correct cleaning of the windows on the airway adapter and the transducer.
- Correct placement of the transducer on the airway adapter.
- Temperature of the patient's breath.
- Amount of water vapour in the patient's breath.
- Barometric pressure at the site of measurement acquisition.
- Other gases, most notably N₂O and O₂, in the gas mixture.

The EtCO₂ (End Tidal Carbon Dioxide) measurement for Carbon Dioxide uses a technique based on the absorption of infrared radiation by certain gases.

Infrared light is absorbed by CO₂. The amount of absorption varies according to the CO₂ concentration in the gas mixture. By using an infrared detector to measure the absorption, the CO₂ concentration in a gas can be derived.

Mainstream CO₂ Features

This illustration shows the user controls on the Server and the connector for the mainstream CO₂ measurement transducer on the Extension. The parts are described in the paragraphs following the illustration:

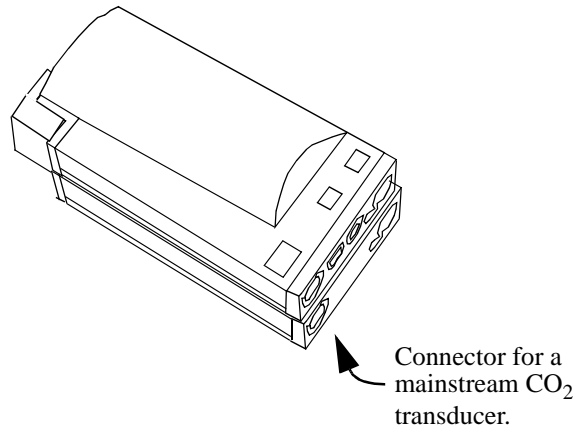

Mainstream CO₂ Wave

The two calibration marks are located at 10% and 60% of wave channel height. The lower calibration mark is labelled 0 mmHg (0.0 kPa) on all scales. The upper one is adjustable from 20 mmHg (2kPa) to 100 mmHg (13 kPa) in steps of 10 mmHg (1kPa).

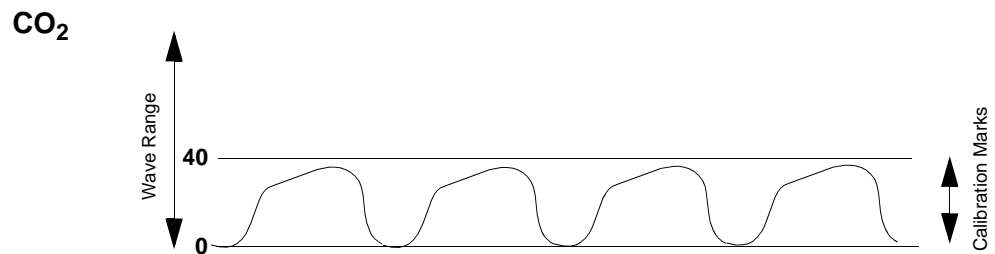

Measurement Mode

In the measurement mode, the Extension continuously measures CO₂ concentration and calculates medical parameters.

- **N₂O Correction**—This can be turned on or off. If N₂O correction is off, only oxygen correction to CO₂ is made. In this case, it is assumed that the gas mixture consists mainly of O₂ and N₂ (respiratory intensive care unit conditions).

If N₂O correction is on, oxygen and N₂O correction to the CO₂ value is made. In this case, it is assumed that the gas mixture consists mainly of O₂ and N₂O (operating room conditions).

- **O₂ Correction**— There is a fixed correction of 45% O₂.
- **Humidity Correction**—This correction is selectable between Body Temperature Pressure Saturated (BTPS) and Standard Pressure Temperature Dry (STPD). The Extension measures BTPS and uses this correction formula:

$$P_{STPD} = P_{BTPS} \cdot \frac{P_{abs}}{P_{abs} - P_{H2O}}$$

where $P_{H2O} = 47\text{mmHg}$

- **Max Hold**—There are three possible selections:
 - **Off**—The EtCO₂ numerics display the breath-to-breath value.
 - **10 seconds**—The EtCO₂ numerics display the highest value within a moving window over a 10-second period.
 - **20 seconds**—The EtCO₂ numerics display the highest value within a moving window over a 20-second period.

Safety

To ensure the safety of the patient, the patient-applied part is isolated from ground by opto-couplers and a transformer. The circuit is also encapsulated in plastic.

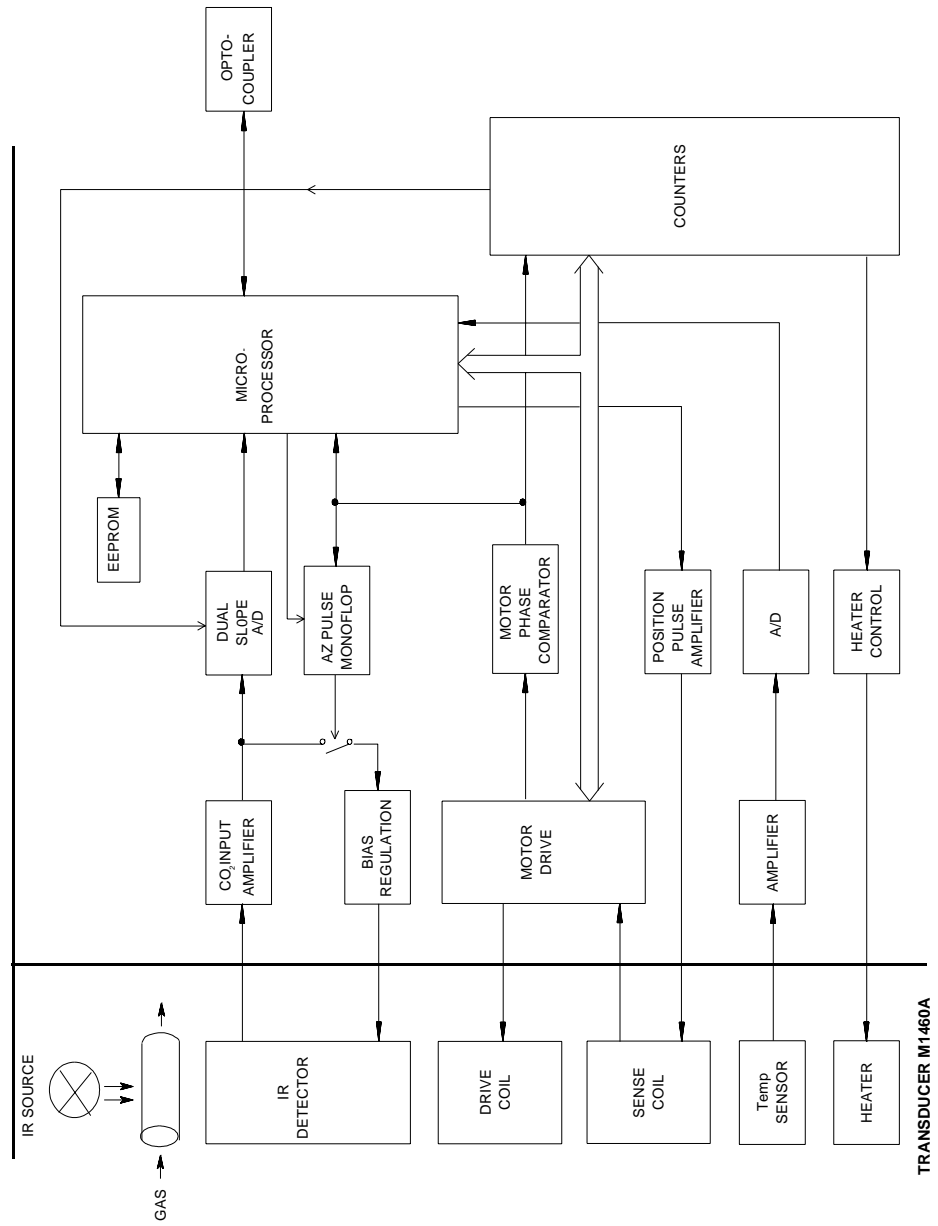
Block Diagram of the Mainstream CO₂ measurement

Theory of Operation for the M3016A Mainstream CO₂

The signals progress through the circuit as follows:

Microprocessor

This is in overall control of the mainstream CO₂ measurement functions. As well, it performs the following functions:

- Serial communication, via optocouplers.
- Calculation of the calibration constants.
- Calculation of the raw data of the mainstream CO₂ waveform.

Temperature Sensor, Amplifier, AIO, Heater Control and Heater

The temperature of the transducer is maintained at approximately 43°C to prevent condensation and to negate any discrepancies due to temperature changes. Signals from the temperature sensor in the transducer are amplified and then passed through an Analog-to-Digital converter. The microprocessor then adjusts the output of the heater control accordingly.

Sense Coil, Motor Phase Comparator, Counters, Motor Drive, Drive Coil

The rotations of the chopper wheel in the transducer are regulated to 40 rotations per second. The sense coil together with the motor phase comparator and the counters are used to measure the actual number of rotations per second. The microprocessor reads the values out of the counters and adjusts the motor drive output accordingly.

Infrared Detector, CO₂ Input Amplifier, Dual Slope A/D, AZ Pulse Monoflop and Bias Regulation

Signals from the infrared detector are amplified and passed through a dual slope Analog-to-Digital converter. This converter is controlled by the microprocessor via the counters. The conversion is started at a predefined time and is performed synchronously with motor rotation.

The following signals are produced and used as the input values for the mainstream CO₂ algorithm:

- Zero (GZ).
- Sample (GS).
- Reference (GR).

An auto zero signal (AZ), which is derived from the output of the motor phase comparator, controls the bias regulation of the infrared detector. The AZ signal is enabled or disabled by the microprocessor.

Tutorial for the Introduction to the Instrument

Question 1: Which is the complete list of what the Measurement Server measure?

- a. The Multi-Measurement Server acquires the physiological signals ECG, respiration, invasive and non-invasive blood pressure, oxygen saturation of the blood, and temperature.
- b. The Multi-Measurement Server acquires the physiological signals ECG, respiration, non-invasive blood pressure, and oxygen saturation of the blood.
- c. The Multi-Measurement Server acquires the physiological signals ECG, invasive and non-invasive blood pressure, oxygen saturation of the blood, and temperature.

Question 2: What is wireless printing? Does the M3046 Monitor support it?

- a. A wireless interface functions in the same way as a normal serial interface except that a modulated infrared beam is used to exchange data and status information instead of a wire connection. Wireless printing is not presently supported on the M3046 Monitor.
- b. A wireless interface functions in the same way as a normal serial interface except that a modulated infrared beam is used to exchange data and status information instead of a wire connection. The IrDA interface in the M3046 Monitor provides a wireless interface to an external printer.
- c. A wireless interface functions in the same way as a normal serial interface except that a modulated infrared beam is used to exchange data and status information instead of a wire connection. There is no such product as yet.

Question 3: According to this Service Guide, how many layers is the Measurement Server software divided into?

- a. 12.
- b. 2.
- c. 4.

Answers to the Tutorial for the Introduction to the Instrument

- 1) a. (See page 2 for more details.)
- 2) b. (See page 15 for more details.)
- 3) c. (See page 21 for more details.)

2 Installing the Instrument

Objectives

In order to meet this chapter's goals, you should be able to complete the installation of the Monitor with a Server and an Extension including all of the following tasks:

- Install the Instrument.
- Configure the hardware.
- Perform post-installation checks.
- Connect a printer.
- Connect a local recorder.
- Comply with safety requirements.

As well, you should be able to perform site preparation and assemble any of the following mounting options:

- Table Mount.
- Universal Bed Hanger.
- Wall Rail.
- Tilt/Swivel Mount.
- Universal Pole Clamp.
- Measurement Server Mounting Plate.
- Infrared Printer Connector.

The appropriate installation procedures are described in this chapter.

Concepts

The following section contains information that you need to understand before attempting an installation of an M3046A Monitor, an M3000A/M3001A Measurement Server and, where present, M3015A/M3016A Measurement Server Extensions.

Instrument Grounding The detachable three-wire power cable grounds the Instrument to the power line ground when plugged into an appropriate three-wire receptacle. This cable protects both the patient and the hospital staff. Do not use any other power cable.

Line Voltage Selection Switch-mode power supply automatically selects the necessary line voltage for the system.

Mounting Surface Analysis The mounting surface frequently dictates the type of screw to be used when mounting the equipment. Ability to analyse the mounting surface protects both the patient and the hospital staff. Do not mount equipment unless the screws are adequate and safe for the purpose.

Safety

Patient Safety

To better secure patient safety, become familiar with the details of the “Monitor and Measurement Server Specifications” chapter of the *Instructions for Use*.

Patient Leakage Current

The patient leakage current is less than 10 μ A at 230V/50Hz. The equipment has floating inputs (Type CF) that are protected against the effects of defibrillation and electrosurgery.

 This symbol indicates that the Instrument is Type CF and is designed to have special protection against electric shocks (particularly regarding allowable leakage currents, having an F-Type applied part, according to the standards IEC 60601-1/EN60601-1/CSAC22.2 601.1/UL 2601-1), and is defibrillator proof.

Preparing to Install the Monitor

WARNING

To avoid contaminating or infecting personnel, the service environment or other equipment, make sure that equipment which has been used before has been appropriately disinfected and decontaminated.

Power Source Requirements

See Electrical Specifications in the Specifications chapter of the Instructions for Use.

Protecting against Electric Shock

The M3046A Monitor is classified as Class I Equipment with an internal power source according to IEC 60601-1/EN 60601-1/CSAC22.2 601.1/UL 2601-1, which means that it is an instrument included in the protective grounding (protective earth) system of the room by way of grounding contacts in the power plug.

To protect the patient and hospital personnel, when operating from an AC source, the cabinet of the Monitor must be grounded. The Monitor is equipped with a detachable 3-wire cable which grounds the Instrument to the power line ground (protective earth) when plugged into an appropriate 3-wire receptacle.

CAUTION

The Monitor uses DOUBLE POLE/NEUTRAL FUSING.

WARNING **Disconnect the Monitor from the AC source by unplugging the power cable from the AC source receptacle or from the AC power connector at the side of the Monitor. The On-Off/Standby button does not disconnect the Monitor from the AC mains supply.**

WARNING **Do not operate the M3046A Monitor on a 2-wire AC supply**

Connect the grounding wire to the equipotential grounding post on the Monitor:

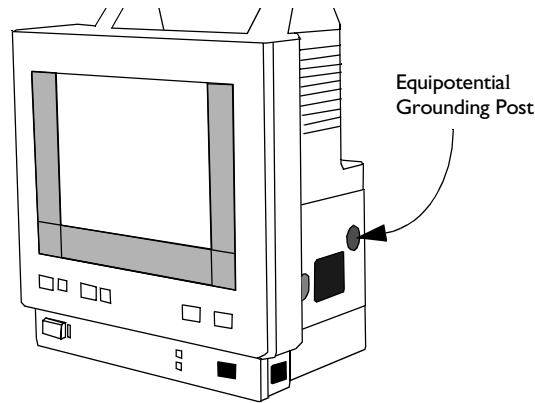

Equipotential Grounding



To eliminate potential differences between different pieces of equipment, in the medically used room, for internal examinations on the heart or the brain, the Monitor must have a separate connection to the equipotential grounding system.

One end of the equipotential grounding cable (potential equalization conductor) is connected to the equipotential grounding post on the side of the Instrument and the other end is connected to one point of the equipotential grounding system.

Examinations in or on the heart (or brain) should only be carried out in medically-used rooms incorporating an equipotential grounding system, according to national standards.

Combining Equipment

All combinations of medical equipment with non-medical equipment must comply with IEC 60601-1-1.

WARNING **If instruments are combined, the summation of the leakage currents can be hazardous to the patient or hospital personnel.**

If it is not evident from the Instrument specifications whether a particular instrument combination is hazardous or not, service personnel must apply measurements and install appropriate IEC 60601-1 compliant means to make sure the combination is safe (see Chapter 4, "Testing the Instrument"). In a likely case, the user must consult the manufacturers to ensure that the summation of leakage currents does not jeopardize patient safety.

Apart from the possible danger caused by leakage currents, no other hazards are known to result from the simultaneous use of the Monitor with other patient-connected equipment.

Environment

To ensure a completely safe electrical installation, follow the instructions described later in “Installing the Monitor”. The environment where the system will be used should be reasonably free from vibration, dust, corrosive or explosive gases, extremes of temperature, humidity, and so on.

Allow at least 2 inches (5cm) clearance around the Instrument for proper air circulation. For a cabinet-mounted installation, allow sufficient room at the front for operation and sufficient room at the rear for servicing with the cabinet access door open.

Approximately 15 minutes after switch on, the Monitor operates within specifications at the ambient temperatures shown in the tables given in Monitor Environmental Specifications and Measurement Server Environmental Specifications in the Specifications chapter of the User’s Guide.













Ambient temperatures that exceed these limits could affect the accuracy of the Monitor and cause damage to the components and circuits.

Make sure that during operation, the Instrument is free of condensation. Condensation can form when equipment is moved from one building to another, thus being exposed to moisture and differences in temperature.

WARNING

Possible explosion hazard if used in the presence of flammable anaesthetics.

Explanation of symbols used:

	Standby for switching the Monitor on and off.
	Attention, consult accompanying documents.
	Infra-red Connector for connection to a printer.
	On the Measurement Server - Defib Data In, that is the ECG marker pulse sent from the defibrillator to the Monitor. The marker pulse is then processed with the ECG signal and displayed on the Monitor. On the M3015A Measurement Server Extension - Gas Input
	<i>On the Measurement Server:</i> ECG Data Out is the analog ECG signal sent out from the Monitor to a defibrillator or other external device, such as an intra-aortic balloon pump. <i>On the M3015A Measurement Server Extension:</i> Gas Outlet/Exhaust. <i>On the Monitor:</i> Data Output to serial recorder
	Serial interface socket for connection to recorder (M3046A #J16 only)
	Alternating Current
	Equipotential Grounding Post (see Equipotential Grounding earlier in this chapter)
	Battery Compartment
	Type CF Applied Part and defibrillator proof with special protection against electric shocks for intracardiac application (regarding allowable leakage currents by having an F-Type isolated or floating section).
	Indicates a Monitor with Wireless LAN Interface (symbol appears on carrying handle)
	Class 2 Radio equipment identifier (1999/5/EC)

Preparing to Install the Monitor

The following are the markings on the back of the Monitor:

This device complies
with FCC part 15
of the FCC rules.

Operation is subject to
the following two conditions:

(1) this device may not
cause harmful interference.

and

(2) this device must accept
any interference received,
including interference that
may cause undesired
operation.

Prod No. M3046A Opt.



Philips

SN: XXXXXXXXXX



Radio module inside
FCC ID IMKRL2630M

CLASS 1
LASER
PRODUCT

D-71034 Boeblingen, Germany

Made in
Germany  2003-05



The printer port uses LED devices for infrared communication with the printer. These LED devices are measured to be AEL Class 1 LED Products per IEC 825-1 and CENELEC EN60825-1 Standards.

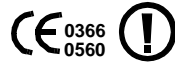

The Philips M3046A Compact Portable Patient Monitor complies with the requirements of the Council Directive 93/42/EEC of 14 June 1993 (Medical Device Directive) and Council Directive 1999/5/EC of 9 March 1999 (Radio and Telecommunications Terminal Equipment Directive).

The following are the markings on the back of the M3001A Measurement Server and the Measurement Server Extension:

Prod No. M30XXA



SN: XXXXXXXXXXXX



Opt: XXX XXX XXXXXX

M30XXA

D-71034 Boeblingen Germany

Shows date
of manufacture →

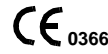

Made in
Germany

CE 0366 The M3001A Multi-Measurement Server and M3015A/M3016A Measurement Server Extension comply with the requirements of the Council Directive 93/42/EEC of 14 June 1993 (Medical Device Directive).

Unpacking the Monitor

The box containing your Monitor comes with the following:

- The Monitor.
- A Power Cord.
- The Instructions for Use and Quick Reference Guide (printed).
- Translation Reference for M3/M4 Monitor Texts (non-Roman-8 languages only).
- Documentation CD-ROM including Instructions for Use, Quick Reference Guide, and Service Guide.

The box containing your Measurement Server contains only the Measurement Server.

The box containing an M3016A Measurement Server Extension contains only the Measurement Server Extension.

The box containing an M3015A Measurement Server Extension contains the Measurement Server Extension and the associated accessories.

In addition you should receive all of the options and accessories that you have ordered.

If anything is missing, contact your Philips Medical Systems representative immediately.

If anything has been damaged in transit, keep the packing material for inspection and contact your Philips Medical Systems representative immediately.

Do not use the Monitor if the casing has been damaged.

If the Monitor is damaged, make sure that the screen is not leaking. There is no known danger from the fluid of irritation to skin or eyes, or by inhalation. The median lethal dose if taken orally is 2.0g/kg.

There are no special procedures necessary for cleaning spilled fluid.

Installing the Monitor

CAUTION

Avoid placing the Monitor, Measurement Server or Measurement Server Extension underneath an infusion bag. Make sure that infusion liquid cannot get into any of the Measurement or Monitor connectors.

Be sure to read the sections on “Preparing to Install the Monitor” on page 64 and “Unpacking the Monitor” on page 70 before continuing.

To install the Monitor you must make sure it has an adequate power supply (see “Preparing to Install the Monitor” on page 64 for information about AC power, and the “Using Your Monitor in Patient Transport” chapter in the *Instructions for Use* for information about using batteries).

Switch the Monitor on using the **On-Off/Standby** button:

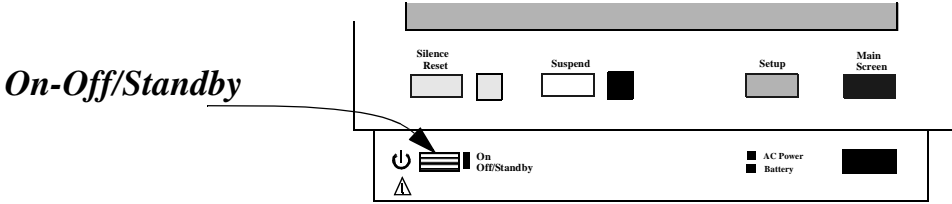

Making the Altitude Setting

A correct altitude setting is important to ensure accurate CO₂ readings.

- Step 1** Enter Config Mode and press the Setup key.
- Step 2** Select Altitude
- Step 3** Select the value from the list which is closest to the altitude of the hospital.

Connecting the Measurement Server...

...with the Measurement Server directly on the Monitor

You can connect the Measurement Server to the Monitor by mounting it directly on the Monitor:

- Step 1** Make sure that your Monitor has a link bar:

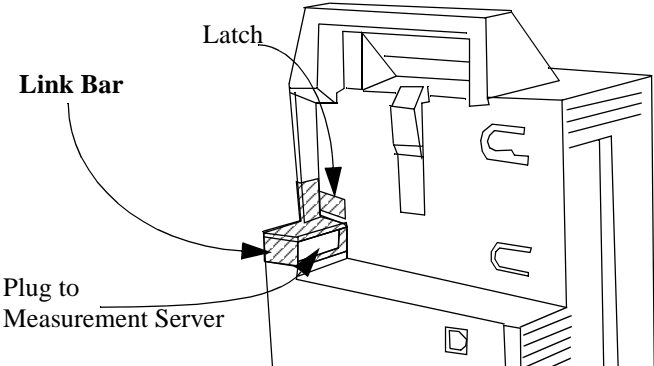

If your Monitor does not have a link bar:

- a. Position the link bar as shown in the diagram above. Make sure that the guide is in the slot under the plug (which connects to the Measurement Server).
- b. Press the Link Bar into position until it clicks.

Connecting the Measurement Server...

c. Turn the latch guard to lie perpendicular across the edge of the latch.

Step 2 Place the Measurement Server on the back of the Monitor.
If it is not tight against the back of the Monitor, slip it away from the link bar until it is.

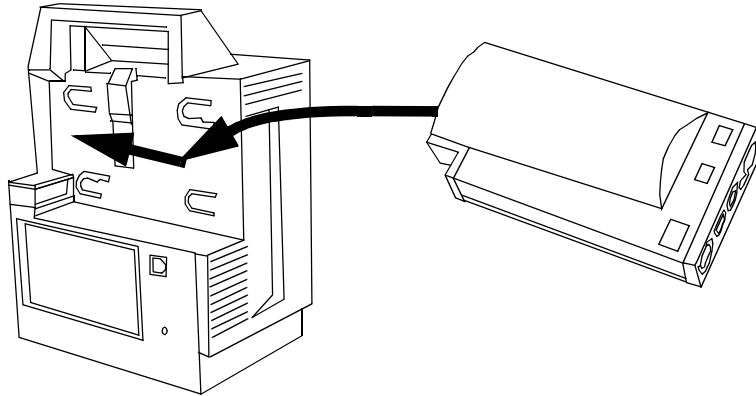

Step 3 Slip the Measurement Server forward until it clicks into place.

To remove the Measurement Server from the Monitor, move the latch (in the middle at the top of the Monitor) toward the front of the Monitor, and slide the Measurement Server away from the link bar:

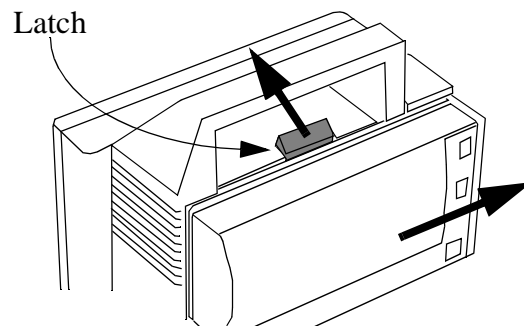

...with the Measurement Server Separate from the Monitor

You can connect the Measurement Server to the Monitor using a server link cable (MSL) as follows:

Step 1 You can connect the cable to the plug on the link bar, or directly to the Monitor as follows:

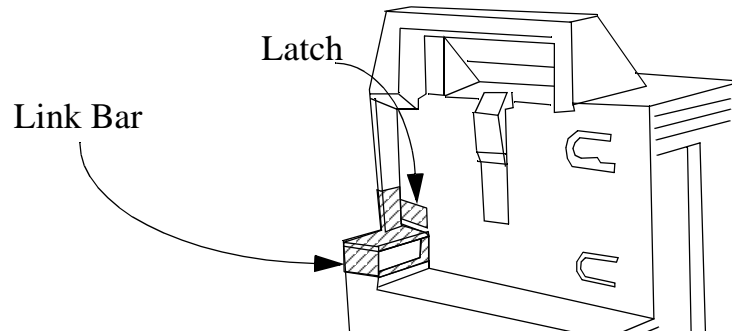

To remove the link bar,

- a. Turn the latch guard away from the edge of the latch.
- b. Unlatch the link bar from the back of the Monitor.
- c. Slide the link bar away from the Monitor.

Step 2 Attach the socket end of the cable to the Monitor.

Step 3 Attach the other end of the cable to the Measurement Server or, if present, the M3015A/M3016A Measurement Server Extension.

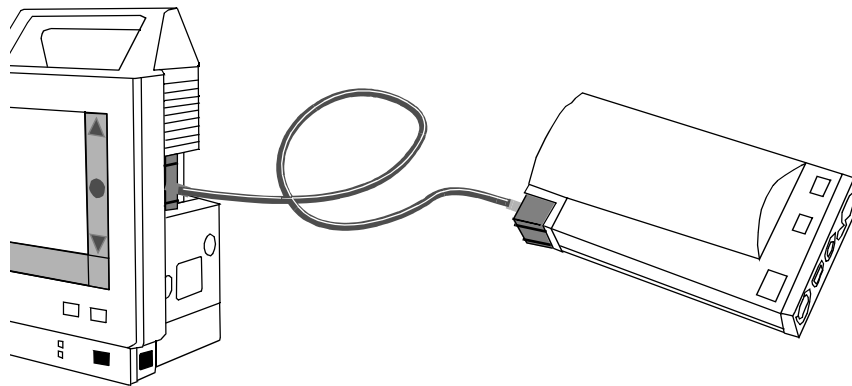

...with the Measurement Server Attached to an M3015A/M3016A Measurement Server Extension

The Measurement Server can be used in conjunction with a Measurement Server Extension. When the Measurement Server is used together with a Measurement Server Extension, CO₂, a second temperature (TEMP) and/or a second invasive pressure (PRESS) may be measured.

An M3015A/M3016A Measurement Server Extension **must** be used with a M3000A/M3001A Measurement Server. The Extension does not function alone.

Attach the Measurement Server to the Measurement Server Extension by sliding it into the grooves on the Measurement Server Extension and clicking it into place.

Attach the combination of Measurement Server Extension and Measurement Server to the Monitor exactly as described above for the Measurement Server, by sliding the Extension into the grooves on the Monitor and clicking it into place.

Attaching the Monitor to a Mount

Step 1 Make sure the front of the Monitor is facing the front of the mount. The front of the mount has a blue button in the center.

Step 2 Lower the Monitor onto the mount until the feet of the Monitor click into the mount.

Detaching the Monitor from a Mount

Step 1 Press and hold in the button (indicated by the arrow) on the front of the mounting .

Step 2 Lift the Monitor away from the mount:

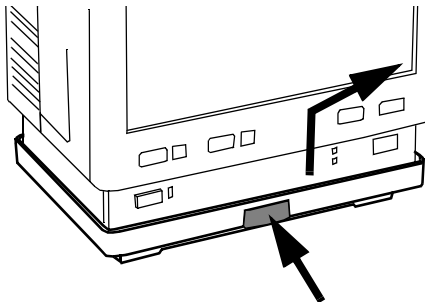

Step 3 Release the button.

Attaching the Measurement Server to a Mount

- Step 1** Make sure the Measurement Server is oriented correctly relative to the mount (see the picture below).
- Step 2** Place the Measurement Server on the back mount.
If it is not tight against the mount, slip it in the direction of the measurement connectors until it is.
- Step 3** Slip the Measurement Server forward until it clicks into place.

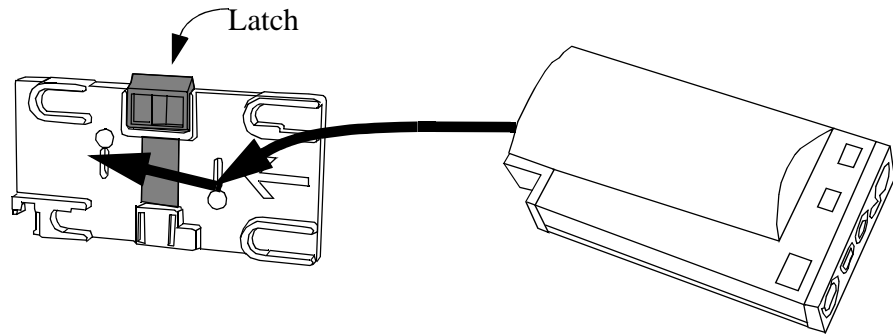

Detaching the Measurement Server from a Mount

- Step 1** Press and hold the latch (in the middle at the top of the mount) away from the Measurement Server.
- Step 2** Slide the Measurement Server off the mount in the direction of the measurement connectors.

Positioning the Measurement Server on a Clamp Mount

For convenience, if you have your Measurement Server on the clamp mount, you can position it with any one of the four edges facing upwards (four positions). Reposition it by completing the following steps:

Step 1 Press and hold the mount latch toward the clamp screw.

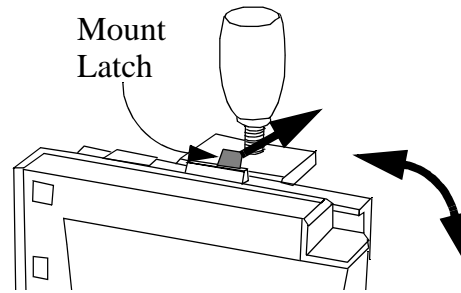

Rotate the Measurement Server and mount until you get it to the position you want.

Step 2 Release the mount latch, and make sure it is clicked into one of the four slots on the back of the mount.

Connecting to the Nurse Call Relay

The nurse call relay is a 3.5mm, mono phone jack socket. It is completely isolated from the rest of the circuitry. Under normal conditions, the tip and sleeve are “open” (not shorted together). When an alarm is indicated, the tip and sleeve are shorted together by a relay.

WARNING

Do not rely exclusively on the Nurse Call Relay for the notification of alarm conditions. The relay output cannot be checked by the Monitor, and the Monitor cannot notify the user of any failure of the relay.

See the specifications for the Nurse Call Relay in the Monitor and Measurement Server Specifications chapter of the *Instructions for Use*, and the documentation for the device you are connecting.

Modification for Nurse Call Alarm Relays

Some customers may want to have an Open-On-Alarm relay instead of a Closed-On-Alarm for their Nurse Call system. Qualified Philips service personnel can modify the connector board, part number M3046-66522.

The modification should be done only on request, in the field. All factory supplied connector boards or monitors have the original board including the Close-On-Alarm Relay.

To make the Open-On-Alarm relay modification, complete the following steps:

Step 1 Cut the existing conductor path on the upper side of the connector board with a sharp implement:

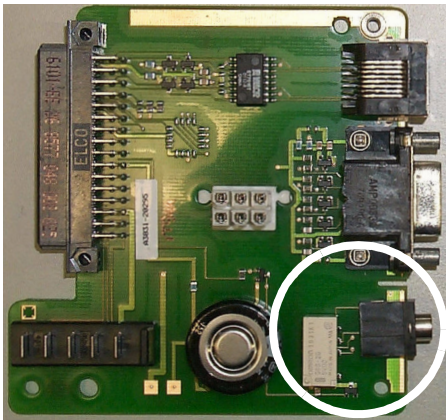

1. Cut connector path

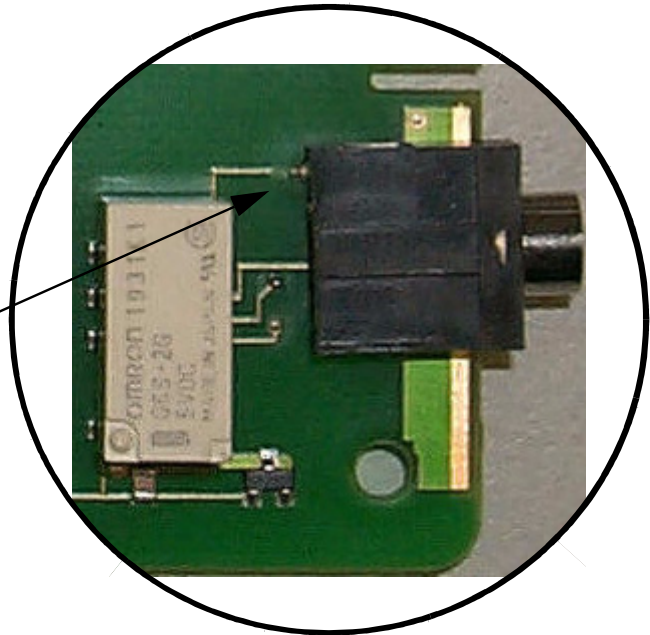

2. Remove Shavings

Step 2 Very carefully remove all copper or plastic shavings from the board.

Step 3 Turn board over.

Step 4 Build the new connection to the Open-On-Alarm contact, shown below.

Using a piece of wire and solder, connect the three (3) points on the bottom of the circuit board as illustrated in the following photographs:

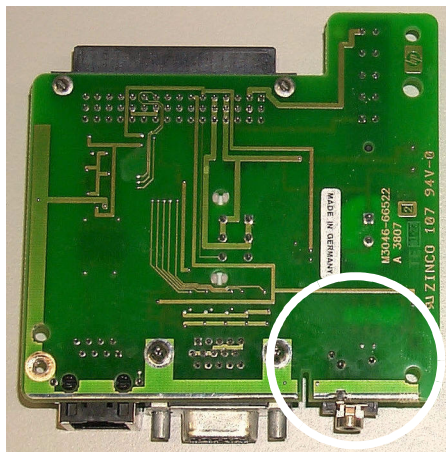

3. Turn board over

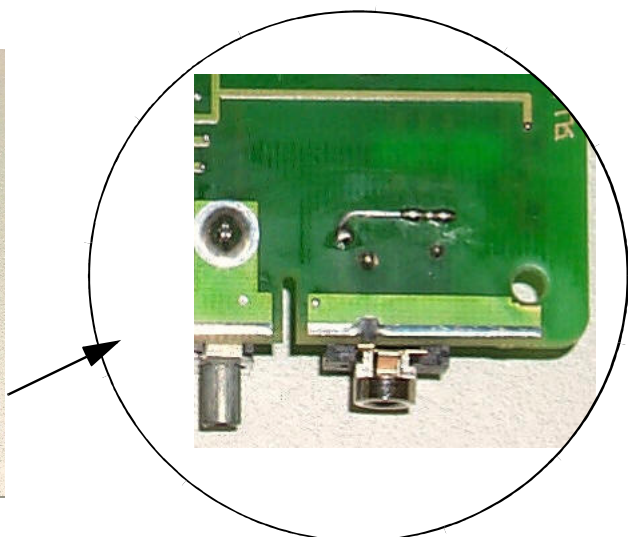

4. Build new connection

Verification Procedure

Perform the following tests.

Step 1 Power on test (see page 142)

Step 2 Nursecall Performance test (see page 157)

Step 3 Safety test (see page 159)

NOTE

You must document the modification for a particular unit, including the verification tests, in the CSO. You must add a printed, dated and signed installation note to the Service documentation of the modified Monitor.

For convenience, we suggest that you attach a label to the instrument next to the output and, using permanent black or blue ink, add localized text similar to:

“Nurse Call is Open-On-Alarm Relay” or “Nurse Call is open”.

Installation of Wireless Infrastructure

See the *IntelliVue Clinical Network Service Manual*.

Please also consult the configuration section of the monitor’s *Instructions for Use* for information on assigning a label to the monitor.

Configuring the Radio Frequency of the M3/M4 Monitor

The **configuration tool** for this procedure is contained on the IntelliVue Information Center Application Software CD ROM that corresponds to your revision of the monitor and Information Center, and must be copied to the PC used for the configuration procedure.

The **configuring PC** must meet the following requirements.

- Microsoft Operating System software (Windows 98 or Windows NT)
- 200 MHz or higher clock speed
- RS 232 serial interface port (9-Pin D type connector)
- contain a CD ROM drive

M3/M4 monitors can have two IP Addresses, one for the monitor itself and one for the Wireless Adapter card that transmits data to the Access Point. The M3/M4 monitor IP Address is set dynamically by the Information or Surveillance Center displaying its monitoring data. This procedure describes how to configure the Wireless Adapter card and set its IP Address.

The following **cable** is required to interconnect the configuring PC to the Wireless LAN adapter in the M3/M4 patient monitor:

- 9-pin D female - 1/8 in. male stereo phono cable (PN M1360-61675)

Copying the Configuration Tools to the Configuring PC

The first step in the procedure is to copy the configuration tool software from the **IntelliVue Information Center Application Software CD ROM** to the configuring PC.

- Step 1** Turn on the configuring PC to display the Windows Main Menu.
- Step 2** Insert the **IntelliVue Information Center Application Software CD ROM** into the CD ROM drive of the configuring PC.
- Step 3** Open **Windows Explorer** as follows:
 - a. Click on **Start** in the lower left of the Windows Main Menu to open the **Windows Workstation** menu.
 - b. Click **Programs** to display the Programs menu.
 - c. Click **Windows Explorer** to display folders in the PC's **CD ROM** drive.

Find the **Viridia** directory on the CD ROM shown in the figure below and click on it to display the **tools** directory.

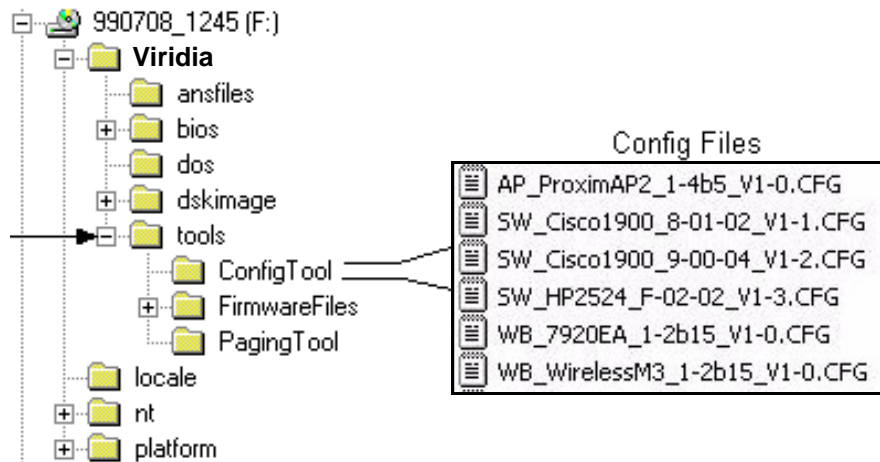

- Step 4** Copy the **Viridia\tools\ConfigTool** directory to the drive on the configuring PC to be used for storing this program as follows:
 - a. Open the directory to be used on the configuring PC
 - b. Click on, hold, and drag the **Viridia\tools\ConfigTool** directory to the open PC directory

NOTE

The Viridia\tools\ConfigTool directory file is less than 1.4 Mb so it can be stored on a 1.4 Mb floppy disk for later use, or for transfer to a PC without a CD ROM drive.

Making the Config Files Writeable

The Config Files are read-only and must be made writeable for the tool to be used for configuration. The following steps describe the procedure after the files have been copied to the configuring computer:

Step 1 Open the **ConfigFiles** directory by clicking on the ConfigFiles folder in the **tools** menu on the configuring PC. The files on the right of the previous figure will be displayed.

NOTE

Step 2 Click on the file labelled **WB_WirelessM3_1-2b15.CFG** to select it. The selected file must be made writeable because settings used in the configuration process are saved to this file so they can be reused when the configuration tool is used again.

Step 3 Place the cursor over either of the highlighted fields and **right-click** the mouse to display a menu listing **Properties**, as shown below:

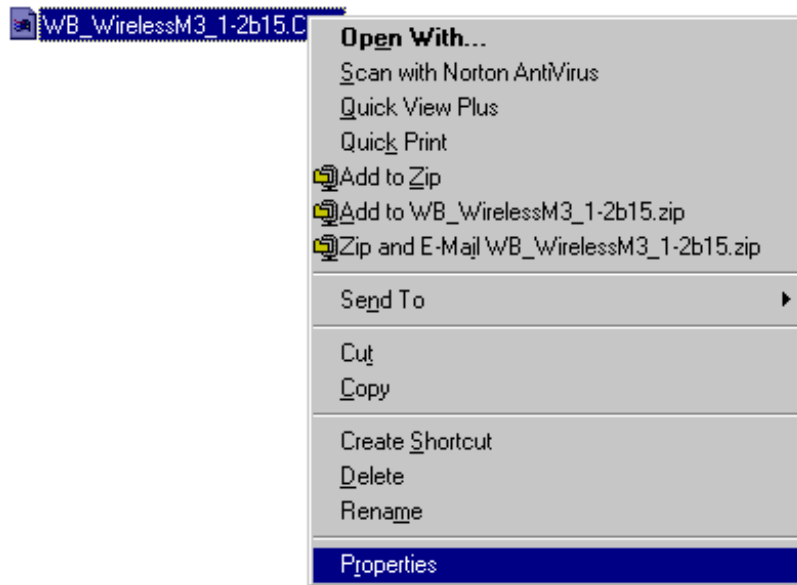

Step 4 Click on **Properties** to display the selected file's **Properties** window.

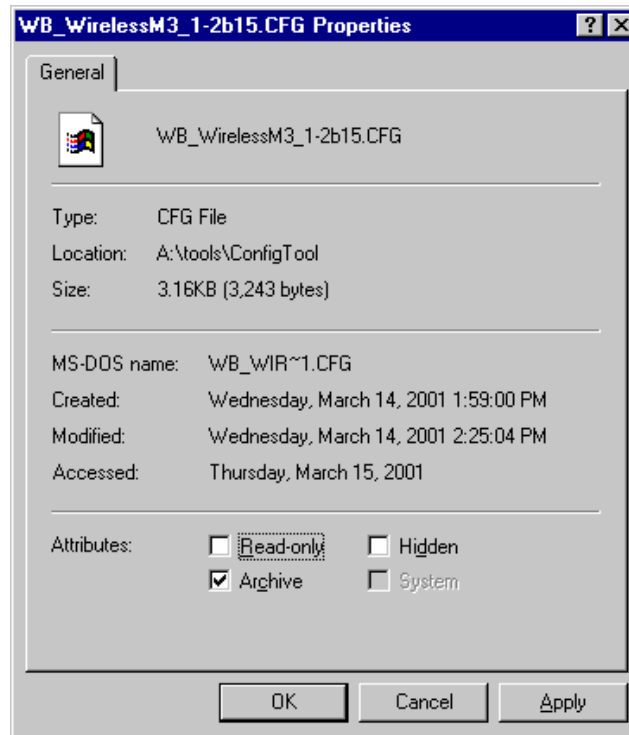

Click in the **Attributes:** box preceding **Read-only** to **remove the check**. This removes Read-only from the selected file.

NOTE

If the configuration tool is run with this file set as Read-only, the following error message will be displayed. Clicking **OK** will exit the tool and the **Read-only** attribute must be removed to clear this condition.



Running the Configuration Tool

Once the tool has been copied and made writeable, it can be run. The first step is to select which device -- Access Point, Switch, or M3/M4 Monitor -- to configure.

Step 5 Run the configuration tools as follows:

- a. select **Start** in the lower left of the Windows Main Menu
- b. select **Run** in the Windows Workstation menu

- c. click **Browse** to access the **Browse** application
- d. select **ConfigTool** in the **tools** menu of the stored configuration tools files
- e. locate the file **ConfigTool.exe** in the ConfigTool directory
- f. double click **ConfigTool.exe** to enter it into the **Open:** field of the **Run** window.
- g. click **OK** to open the **Configuration Tool** window:

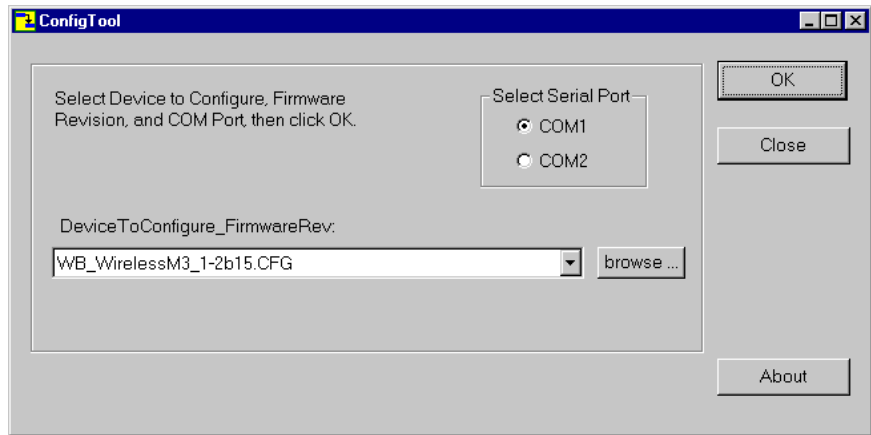

The Configuration Tool Window is used to select the Serial Port (**COM1** or **COM2**) on the configuring PC that will be used to perform the configuration and the configuration file for the device being configured -- **Access Point, Network Switch, or Wireless Bedside.**

- Step 6** Select the Serial Port to be used (**COM1** or **COM2**) in the Select Serial Port field by clicking in the circle preceding the appropriate port.
- Step 7** Select the appropriate Device to Configure in the drop down list in the **Configuration Tool** window of the configuring PC. See previous figure.
- Step 8** Select the file **tools\ConfigTool\WB_WirelessM3_1-2b15.cfg** in the Configuration File fields.
NOTE If this file does not automatically appear in the Configuration File field, click **Browse** and find this file on the computer drive directory where it was stored.
- Step 9** Turn **OFF** the power of the Wireless M3/M4 Monitor and disconnect any cable connected to the RJ-45 port on its rear panel.

- Step 10** Unsnap the gray cover on the upper right side of the M3/M4 Monitor housing to expose the female stereo phono plug on the Wireless Adapter, as shown in the next figure:



- Step 11** Connect the phono plug end of the 9-Pin D female - 1/8 in. male Stereo Phono cable into the phono plug connector on the Wireless Adapter as shown above and the 9-pin D end of the cable into the 9-Pin D Serial Port connector on the configuring PC.
- Step 12** Turn **ON** the M3/M4 Monitor and insure that it passes its self-test.
- Step 13** Select the **WB_WirelessM3_1-2b15.cfg** item in the drop down list in the **Configuration Tool** window.

Step 14 Click **OK** to open the **Wireless Bedside Parameters** window:

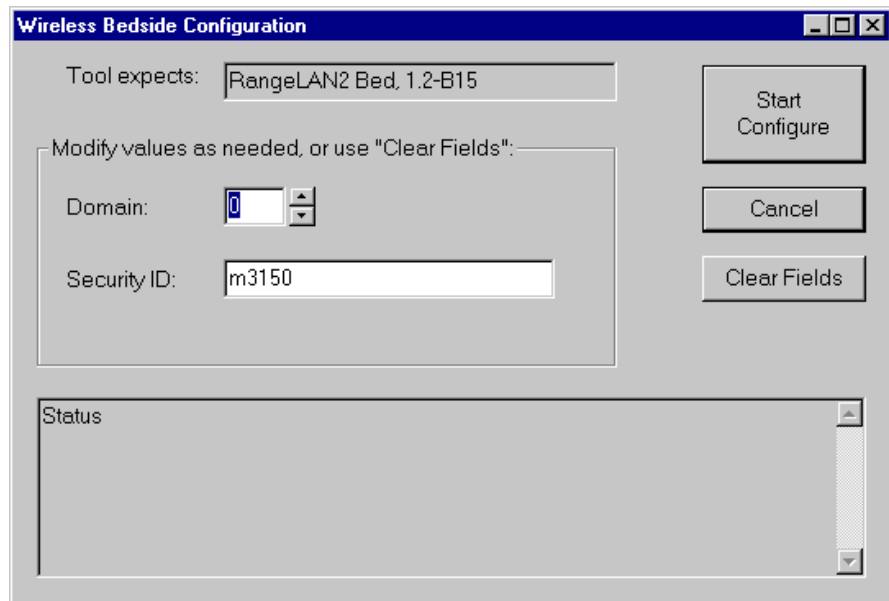

Step 15 Modify the “domain” field according to your design requirements. Refer to Appendix A of the M3185A *IntelliVue Clinical Network Service Manual* for the appropriate wireless configuration worksheets.

NOTE

Security ID: Keep the default entry **m3150**.

If an error message appears, see **Troubleshooting** in the **Access Point** section.

This configuration process takes about 1 minute. During configuration, status messages will be displayed in the field at the bottom of the **Wireless Bedside Parameters** window as the tool resets the configuration to factory default values, sets the configuration parameters, and then resets the Wireless Adapter.

When the tool has successfully completed the configuration, the **Wireless Bedside Configuration is completed successfully** window is displayed:

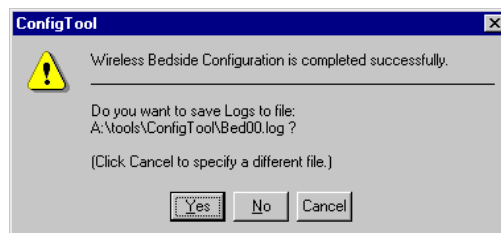

The configuration tool will write the configuration dialog and summary information to a file if you wish. It will create a **Log file** name by combining **Bed** and the **2 digits** of the Domain entered in the **Wireless Bedside Parameters** window.

NOTE

Step 16 Create a **log file** of the Wireless Bedside configuration.

The **log file** is a **.txt** file that contains the menu dialog of the most recent configuration. Near the end of this file is a summary of the device's configuration settings. This file may be viewed in **Notepad** or printed for later reference.

There are several configuration settings for the M3/M4 monitor that are made by the configuration tool that are not site specific but are different from factory default settings. These settings can be seen in the log file, but are not displayed to the user when the tool is used.

- If you want to create a log file with the **Log file** name given, click **Yes** and a **log file** containing the text of the menu dialog between the configuring PC and the Wireless Adapter will be created and stored in the **C:\tools\ConfigTool** directory of the configuring computer's hard drive.
- If you want to specify a **different filename**:
 - a.click **Cancel** and a window will open allowing the specification of a different filename.
 - b.enter the new filename in the field provided.
 - c.click **Yes** to create a logfile with the new filename.
- If you do not want to create a log file, click **No** to close this window.

NOTE

If a **filename** is entered for which a configuration file already exists, that file will be overwritten by the new file.

Configuration of this Wireless Adapter is now complete.

Step 17 Remove the phono plug from the rear of the Wireless Adapter and replace the cover.

Step 18 If there are additional Wireless M3/M4 Monitors to be configured, repeat **Step 1** through **Step 12** for each monitor.

NOTE

The **Configuration Tool** retains the parameter values entered when it was previously run.

For each Wireless Adapter configured, enter the parameters for that Wireless Adapter in the Wireless Bedside Parameters window.

It is possible that all of the Wireless M3/M4 Monitors in a system will have the same configuration parameters.

When all Wireless M3/M4 Monitors have been configured:

Step 19 Click **Close** in the upper right corner of the Configuration Tool window.

Troubleshooting

If an error should occur during the configuration process, one of the following troubleshooting procedures may resolve the problem.

If the **Read-only** attribute has not been removed from the configuration tool files, the following error message will be displayed.



- Click **OK** to exit the tool and remove the **Read-only** attribute following the procedure described in **Making the Config Files Writeable**.

If the serial cable connecting the configuring PC to the device or the PC's **COM** port is inaccessible or not working, one of the following windows will be displayed:



For Wireless Adapter

- Check the serial cable and its connections carefully to assure that a good interconnection is being made
- Ensure that no other applications in the configuring PC have control of its Serial Port (e.g. Hyperterminal). Close all other applications.
- Ensure that the proper **COM** port is selected in the **Configuration Tool** window.

If configuring a **Wireless Adapter**:

Turn the Wireless M3/M4 Monitor **Off** and then **On** and ensure that it passes its self-test. Restart the **Configuration Tool** and try the procedure again.

Connecting to the ECG Output or Marker Input

See the specifications for the ECG Output and for the Marker Input under Interfaces in the Monitor Performance Specifications section of the Specifications chapter of the *Instructions for Use*, and the documentation for the device you are connecting.

Configuring the Monitor

See the Basic Operation chapter and the Configuration chapter of the *Instructions for Use*, as well as the setup sections for each of the measurements for more information on Monitor setup.

There is a second level of configuration for the Monitor which is only available after entering a password. See the Installation chapter and Configuration chapter of the User's Guide for more information.

Selecting NBP Measurement Characteristic

Only software revisions D and later allow the NBP Measurement Characteristic to be changed.

WARNING

Consult technical support before changing the NBP measurement characteristic in Adult or Pediatric mode. Changing the NBP measurement characteristic will significantly change the NBP readings, especially in the elevated pressure range. The setting of NBP Measurement Characteristic is not transferred as part of a cloning operation with the cloning tool. It has to be set on each monitor separately.

NOTE

This setting changes the NBP measurement characteristic in adult and pediatric mode. It has no influence to the NBP measurement characteristic in neonatal mode. In neonatal mode always the intraarterial method is used as reference standard to validate the overall accuracy.

For the M3046A Monitor with software revision E:

Step 1 Highlight the NBP numeric and press on the TouchStrip.
OR

Step 1 Press the **Setup** key.

Step 2 Move the highlight to "NBP".

Step 3 Press on the TouchStrip.
(When you are finished with the NBP Setup, press the **Main Screen** key.)

Step 4 Select **Reference**.

Step 5 Select **Auscult.** or **Invasive**.

For versions of the M3046A Monitor with software revision D or lower, do the following. In service mode:

Step 1 Select 'Setup NBP'

Step 2 Select 'Cal Mode'

Step 3 Select desired NBP measurement characteristic according to the table and graphs below:

Selection	Factory Default	Description
2	NBP measurement characteristic of M3/M4 Rel. B and earlier. Recommended if customer prefers calibration against manual auscultatory reference method.	Auscultatory according to ANSI/AAMI SP10-1992. The blood pressure measurements determined with this device and measurement characteristic set to "2" comply with the American National Standard for Electronic or Automated Sphygmomanometers (ANSI/AAMI SP-10-1992) in relation to mean error and standard deviation, when compared to auscultatory measurements in a representative patient population. For the auscultatory reference the 5th Korotkoff sound was used to determine the diastolic pressure.
3 (Factory Default)	NBP measurement characteristic of M3/M4 Rel. C and D. Recommended if customer prefers calibration against intra-arterial reference method.	Intra-arterial according to ANSI/AAMI SP10-1992. The blood pressure measurements determined with this device and measurement characteristic set to "3" comply with the American National Standard for Electronic or Automated Sphygmomanometers (ANSI/AAMI SP-10-1992) in relation to mean error and standard deviation, when compared to intra-arterial measurements in a representative patient population.

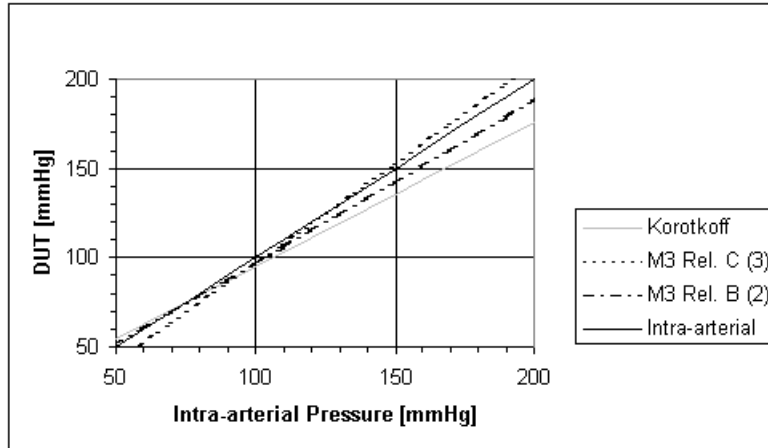

Figure 1 Systolic readings of NBP Measurement Characteristics for M3 Release B and M3 Release C compared to readings obtained using the manual auscultatory method (Korotkoff) and direct arterial measurement.

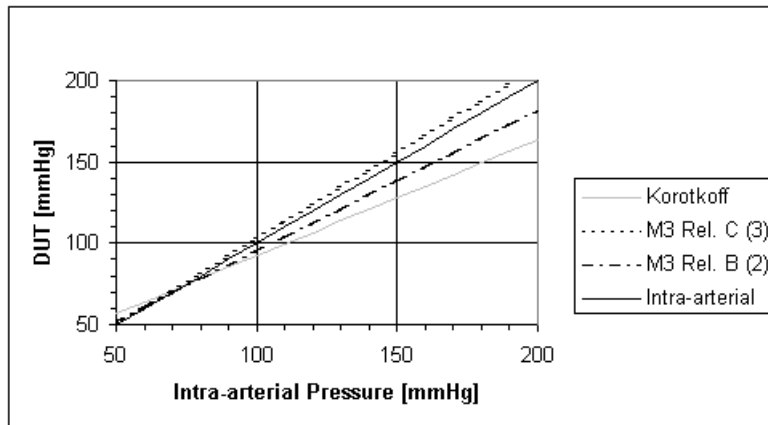

Figure 2 Diastolic readings of NBP Measurement Characteristics for M3 Release B and M3 Release C compared to readings obtained using the manual auscultatory method (Korotkoff) and direct arterial measurement.

The data for Figure 1 and Figure 2 was derived from M3 Clinical Evaluations and “Auscultatory Measurement of Arterial Pressure During Anesthesia: a Reassessment of Korotkoff Sounds”, E. Pereira et al., European Journal of Anesthesiology 1985, 2, II-20.

The setting of NBP Measurement Characteristic is stored in the Measurement Server. If the Measurement server is moved between monitors the setting will travel with the Measurement Server.

Installing an Additional Display

An additional display must be installed by an Philips Medical Systems service engineer or authorized Service Representative. By the addition of a display, the M3/M4 Monitor becomes a system and must be safety-tested as such after installation. The required tests are described in “Testing the Instrument” on page 137.

Displays

WARNING

In situations where the additional display is situated *outside* of the medically-used room (see IEC 60601-1-1), the additional protective earth connection is a *requirement*, or alternatively, electrical isolation must be provided by using a separation device depending on the value of the measured enclosure leakage current.

Any display which meets the specifications for the VGA interface may be used with your monitor. When connected to the patient monitor, these displays (along with any other Class I non-medical equipment) must comply with IEC 60950 and with IEC 60601-1-1 when connected to the M3/M4 Monitor.

If the resulting enclosure leakage current of the display exceeds the value laid down by IEC 60601-1/60601-1-1, then certain action needs to be taken to ensure that the system as a whole meets safety standards that are equivalent to those contained in IEC 60601-1/60601-1-1.

What action to take depends on the measured enclosure leakage current of the display, and where the display is located (is it in the patient vicinity, outside the patient vicinity but still in the medically-used room, or outside of the medically-used room?).

The following two tables show what action to take.

Resulting Earth Leakage Current of the Non-Medical Device		
	Normal Condition	Single Fault Condition
Result 1	$\leq 0.1\text{mA}$	$\leq 0.5\text{mA}$
Result 2	$\leq 0.1\text{mA}$	$\geq 0.5\text{mA}$
Result 3	$\geq 0.1\text{mA}$	$\geq 0.5\text{mA}$

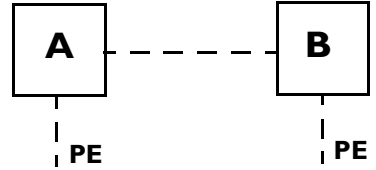
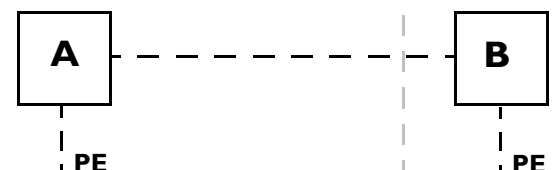
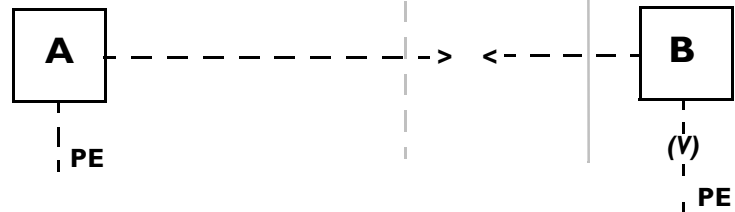
Patient Vicinity	Medically-Used Room	Outside Medically-Used Room	Action Required Following Earth Leakage Current Measurement (See Table above)		
			Result 1	Result 2	Result 3
 <p>Here the patient monitor is connected to a non-medical device (display), and both pieces of equipment are within the patient vicinity (within 1.5m of the patient).</p>			No action required	Additional protective earth OR separation device required	Separation device required
 <p>Here the patient monitor is connected to a non-medical device (display) that is outside the patient vicinity, but within the medically-used room.</p>			No action required	Additional protective earth OR separation device required	Separation device required
 <p>Hazardous situations may occur if the signal line of the patient monitor is connected to equipment outside of the medically-used room (for example, in another building with a different mains supply circuit). A separation device (for example, an separation transformer) included in the signal line prevents a hazard to the patient or user. It should be placed as near as practicable to the medical electrical equipment. The inclusion of a separation device also helps to avoid hazards through malfunction of equipment caused by unwanted ground loop currents flowing through the signal line.</p>			It is recommended to us a separation device, even if the measured enclosure leakage current does not exceed the value laid down by IEC 60601-1-1	Separation device between the medical device and the non-medical device required	Separation device between the medical device and the non-medical device required
Key:	PE = Protective Earth	(V) = Potential difference between different localities	> < = Separation device		

Where **separation transformer** is required, the power cable connection to the display must be secured so that the transformer cannot be disconnected by hand.

Where an additional **protective earth** is required, the grounding cable must be screwed to the protective earth connector on the rear of the Monitor (see the illustration below under “Installation” on page 92). The other end of the grounding cable must be connected to ground (earth) with a screwed connection.

Safety Specification

Enclosure leakage current for the combination of M3046A monitor, additional display and isolation transformer must meet the following requirements:

IEC 60601-1	500 microamps (μ A) rms at 264V, 50/60 Hz
UL 2601-1	300 microamps (μ A) rms at 240V, 60 Hz
CSA C22.2 #601-1	500 microamps (μ A) rms at 264V, 50/60 Hz

Installation

WARNING Do not touch the patient when connecting or disconnecting the cable to the Video Out connector.

CAUTION When an additional display is connected, and an additional protective earth connection is needed to be made to the Monitor, this protective earth connection may only be used if the leakage current does not exceed the limits of IEC 60601-1 in normal condition.

A Video Out connector is provided on the rear of the Monitor for connection to an additional display, as shown below.

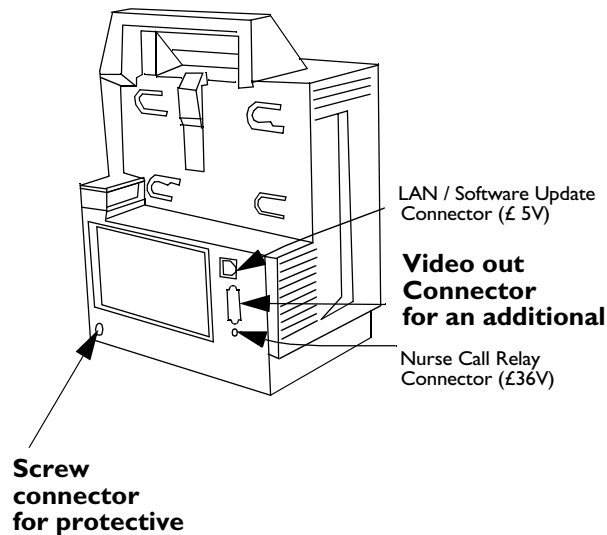

Installing the 12V Adapter

The 12V adapter (option number M3080A #C32) is used with a vehicle 12V supply to power an M3/M4 Monitor. The Adapter must be connected to ground or to the vehicle chassis. Detailed instructions can be found in the Instruction sheet delivered with the Adapter (M3080-9011A). After installation, a safety test must be performed as described in Chapter 4, “Testing and Inspecting”.

Using the Battery Charger and Conditioner

The Battery Charger and Conditioner (M8043A, part number M8043-60000) is an external device used to recharge and condition the monitor’s battery. To use the Battery Charger and Conditioner, follow the instruction sheet delivered with it. For more information on battery use, see the “Using Your Monitor in Patient Transport” chapter in the Instructions for Use.

Connecting a Printer

Selecting a Printer

If you are printing locally, you can use either of the following accessories:

- a PCL 3 or PCL 5 compatible printer, with an infrared-to-parallel converter (JetEye[®] Printer wireless infrared connector), which you can order as M3080A Option #H05, or
- a PCL 3 or PCL 5 compatible with a built-in infrared interface.
You can also use the LaserJet with the JetEye, but then you will also need a Centronics printer extension cable. (Installing the wireless infrared printer connector is covered on page 94).

Make sure that the infrared printer port is at least 50cm (20 inches) from any SpO₂ transducer while you are printing, to avoid disturbing the SpO₂ measurement.

Note that the M3 Print Server is no longer available, but is mentioned here for those who still use it.

Step 1 Press the **Setup** key.

Step 2 Move the highlight to **Printer**.

Step 3 Press on the strip to select the Printer window.

Step 4 Move the highlight to **Printer**.

Step 5 Press on the strip.

Step 6 Select the appropriate setting according to the following table:

None	If there is no printer. All printing operations are disabled.
------	---

Local	To enable a local printer.
Remote ^a 1	To enable a printer connected through the network. ^b
Remote ^a 2	To enable a printer connected through the network. ^b
Remote ^a 3	To enable a printer connected through the network. ^b

- a. The remote printer option is only available when the Monitor is connected to the M3 Print Server.
- b. If any Remote printers are available, there will always be three printers shown irrespective of the actual number of printers connected via the M3 Print Server. The correlation to actual printers on the network is configured at the M3 Print Server.

Installing the Wireless Infrared Printer Connector (M3080A #H05)

If the Monitor is to be used within the patient vicinity when it is connected to a printer, the connection must only be made using the Wireless Infrared Printer Connector. To use this, you need a Centronics printer extension cable.

The Wireless Infrared Printer Connector provides an infrared printer connection from the infrared-equipped Monitor to a parallel printer by attaching to the standard parallel printer connector and providing both a parallel and an infrared interface.

To find out how to install the Wireless Infrared Printer Connector software, refer to the accompanying documentation. Install the device support tray (supplied with kit) and connector as follows:

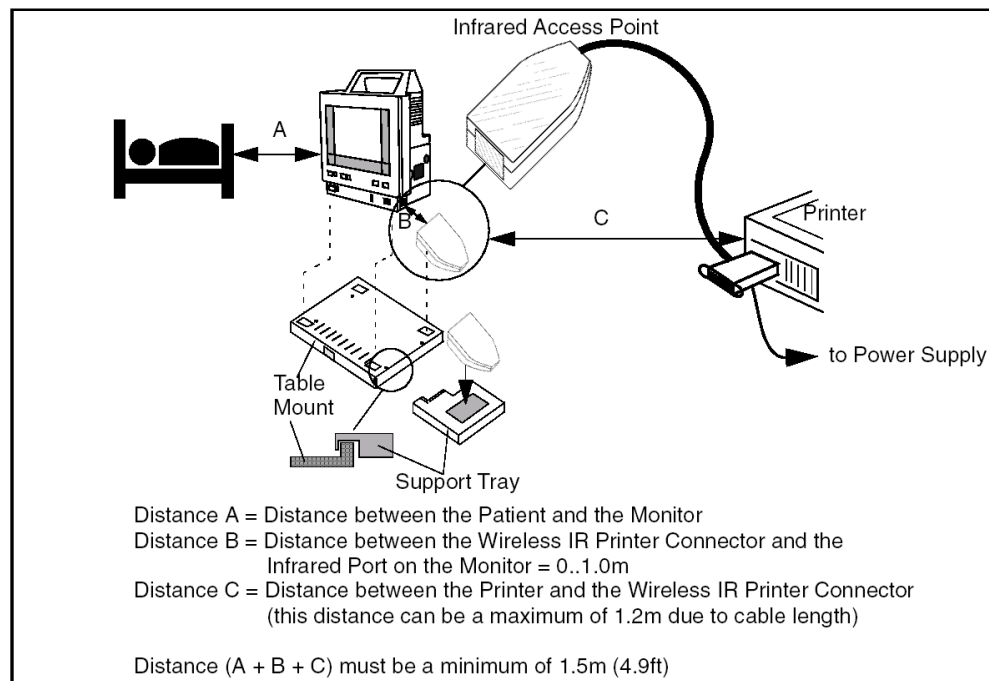

- Step 1** Attach the support tray to the front, right corner of the table mount. The plastic support tray push-fits over the lip of the table mount. Make sure the dove-tail slot on the tray engages with the table mount correctly.
- Step 2** Remove the adhesive protection strip from the support tray and attach one half of the velcro fixing onto it. Attach the other half of the velcro to the bottom of the Wireless Infrared Printer Connector by peeling off the protective label.
- Step 3** Attach the Wireless Infrared Printer Connector firmly onto the support tray, ensuring that the velcro fixings align. (It may be helpful to place the Monitor in position to line-up the infrared devices).

Connecting a Local Printer

WARNING

The printer and any other non-medical equipment (such as the infrared to parallel converter) are not allowed to be used within the patient vicinity (1.5m/4.9 ft).

If you are using an infrared to parallel converter, do the following:

- Step 1** Connect the parallel port to the printer.
- Step 2** Position the converter according to the following guidelines:
- within 100cm (40") of the infrared port, and
 - within 15° of the line perpendicular to the plane of the port.

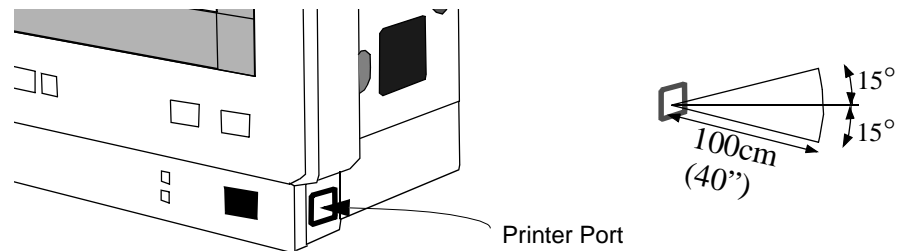

You can use the JetEye holder (which comes with the M3080A Option #H05) for optimal positioning of the JetEye.

Read the documentation supplied with the JetEye for information on the JetEye power supply, the correct connection and so on.

If you are using a printer with a built-in infrared port, position the printer according to the following guidelines:

- within 100cm (40”) of either infrared port, and
- within 15° of the line perpendicular to the plane of the port.

Connecting a Remote Printer

For remote printing on a network printer, the Monitor must be connected to the M3 network. The network cable is connected to the LAN socket on the back of the Monitor.

WARNING

The Monitor must be connected to the dedicated M3 network only. The special network cables supplied by Philips Medical Systems for this purpose must be used (see the *IntelliVue Clinical Network Service Manual* for details).

Connecting a Local Recorder

You can connect a standalone strip chart recorder (option M3080 #H20, GSI Lumonics XE-50p) to your monitor via the serial recorder interface, available as option M3046A #J16. A dedicated cable is supplied with the recorder. Details of how to set up, use and care for the recorder are given in the *Operator's Manual* that accompanies it. Additional information can be found in the Monitor's Instructions for Use.

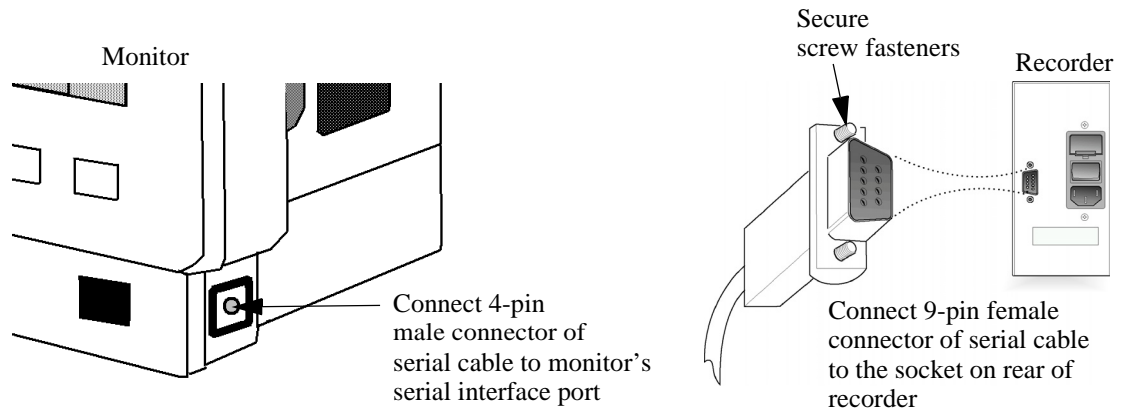

Step 1 Connect the 9-pin female connector of the serial interface cable to the socket on the rear of the recorder. Ensure that the DB9 connector is firmly fitted to the socket and secure it by tightening the screw fasteners.

Step 2 Connect the 4-pin male connector of the serial interface cable to the serial interface port on the monitor marked with the ☺ ➔ symbols.

Order the Roll Stand (M3080A Option #A30) or the Wall Mount (M3080A Option #A31) for a dedicated mounting solution for your recorder. See “Mounting Options for the Local Recorder” on page 111.

The following recordings are supported:

- Start/Stop real-time
- Start/Extend delayed
- Alarm
- Vital signs
- Trends and stored events

The recordings always show the first three displayed wave forms. The height of the wave channels is automatically adjusted according to the number of waves displayed:

Wave Channel	Number of Waves		
	3	2	1
Channel 1	2 cm	2 cm	4 cm
Channel 2	1 cm	2 cm	-
Channel 3	1 cm	-	-

Only Roman-8 characters are shown on the recorder. Monitor texts are sent to the local recorder, printer or Information Center in English for monitors marketed in some East European and Asiatic countries. Refer to the booklet “Translation Reference for M3/M4 Patient Monitor Texts” for a translation of the English text into the localized language.

Site Preparation Guidelines

Although the Instrument (Monitor and Measurement Server or, where present, Measurement Server Extension) is primarily a portable Monitor, some site preparation must be done before using it in certain locations. Additionally, good operating practices are also recommended.

- Check that the operating environment is reasonably free from dust, vibration, corrosive or explosive gases and is within specified temperature and humidity ranges.
- Position the Instrument so that the display is clearly visible and the controls are easy to reach.
- The M3046A **MUST** be grounded during operation. If a three-wire receptacle is not available then a hospital electrician must be consulted to ensure that proper grounding is available on installation. **NEVER** attempt to use a three-wire to a two-wire adapter with the M3046A. The Instrument must be grounded whenever it is connected to the mains power using a 3-pin plug.

Mounting Solutions

The mounting solutions described in this manual are subject to change. For the latest information, please visit the Patient Monitoring section of the Philips Medical Systems website, and follow the links to mounting solutions.

For detailed mounting instructions, refer to the documents supplied with the mounting hardware.

Installing the Table Mount (M3080A #A10)

The Table Mount is intended for any flat, level surface. To mount the plate securely, you need 4 screws. These are not provided because the type of surface dictates the type of screw.

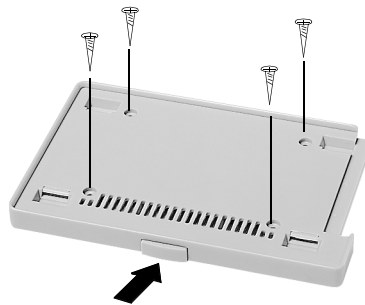

- Step 1** Unpack the Table Mount and check all parts are available.
- Step 2** Select 4 screws (appropriate to surface material).
- Step 3** Insert the 4 screws through the screw holes provided in the plate.
- Step 4** Tighten the screws.

The Monitor snap-fits onto the plate. To release the Monitor, press the button on the front of the plate.

This mount is also:

- available as support part M3080-63201
- used for the Rollstand mount M3080A #A22

Installing the Universal Bed Hanger (M3080A #A11)

The hanging mount is used for hanging the Monitor on the bed footboard/headboard or a rail. It is delivered ready-to-use and does not require installing.

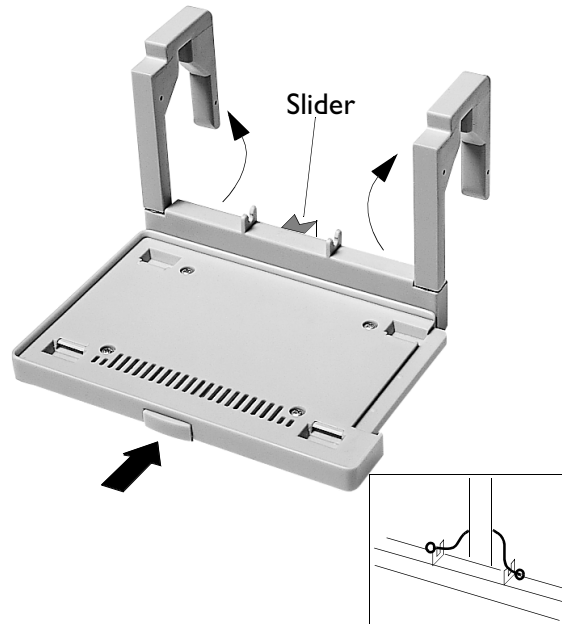

- Step 1** Unpack the Bed Hanger and check all parts are available.
- Step 2** Rotate the arms to their open position.
- Step 3** Hang the hanger on the rail (or as appropriate).
- Step 4** If necessary, adjust the bed hanger to a vertical position by pulling out the slider at the rear of the hanger.
- Step 5** If necessary, fix the bed hanger by hooking the rubber strap around a vertical bar (as shown in the insert).

The Monitor snap-fits onto the plate. To release the Monitor, press the button on the front of the plate.

Warnings, Cautions, and Safety Precautions Relating to Wall Mount Installation

- Make sure that you have read all applicable instructions before attempting to install the wall mount.
- Wall mounts that are intended to support monitors must be capable of supporting four times the weight of the Monitor when properly installed.

If wall mounts are to be installed on plaster board walls, we recommend that the mounts be installed using steel or plywood plates sufficient to distribute the load over a large section of the wall. ***Lead expansion bolts are neither adequate nor safe for this purpose.***

- It is the responsibility of the hospital, institution, or its designated representatives to determine that the wall is adequate to safely mount monitoring instrumentation. This includes the selection of and proper installation of the appropriate fasteners and mounts. In a new construction, or in a remodelled construction where the wall can be completely or partially removed, a 16-gauge steel stud should be mounted for the purpose of attaching the wall channel. This design safety factor is based on four times (4x) the maximum rated load.
- **GCX Wall Channel:** Always reposition the adjustable channel safety stop under the adapter plate when the height of the Instrument is changed.

The channel safety stop prevents the mounting device from inadvertently falling or being pulled out of the wall channel. ***Do not remove this stop while the mount is supporting an Instrument.***

- Do not mount any portion of a monitoring instrument over a patient's bed.
- Do not exceed the maximum rated load specified for each wall mount.
- Ensure that no electrical wiring, utilities, or piping interfere with the selected wall mounting location.
- Do not install wall channel onto solid brick or brick veneer walls. Do not attempt to install wall mounts onto crumbly wall material.
- Check the mounting hardware holding the wall channel or bracket to the wall every 12 months. Tighten if necessary.

Installing the Wall Rail (M3080A #A13)

The wall rail is intended for use with the Universal Bed Hanger (#A11). To mount the rail securely, you need 3 screws. These are not provided because the type of surface dictates the type of screw used.

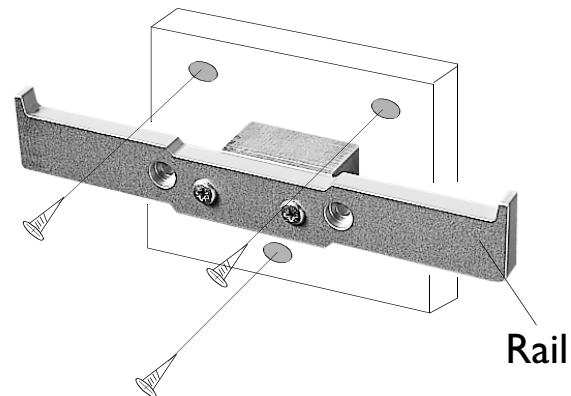

- Step 1** Unpack the Wall Rail and check all parts are available.
- Step 2** Select 3 screws (appropriate to surface material).
- Step 3** Insert the 3 screws through the screw holes provided in the plate.
- Step 4** Tighten the screws.
- Step 5** Hang the bed hanger over the wall rail.

Installing the Tilt/Swivel Mount (M3080A #A14)

The Tilt/Swivel mount can be used in the following situations:

- Screwed directly to a wall.
- Mounted to the GCX Wall Channel #A15 (described in the following section).
- Attached to the Universal Pole Clamp.
- Attached directly to the Monitor.

Screwed Directly to a Wall

This option is used to mount the Monitor on a wall but to also provide tilt and swivel capability. To mount the assembly securely, you need 3 screws. These are not provided because the type of surface dictates the type of screw used.

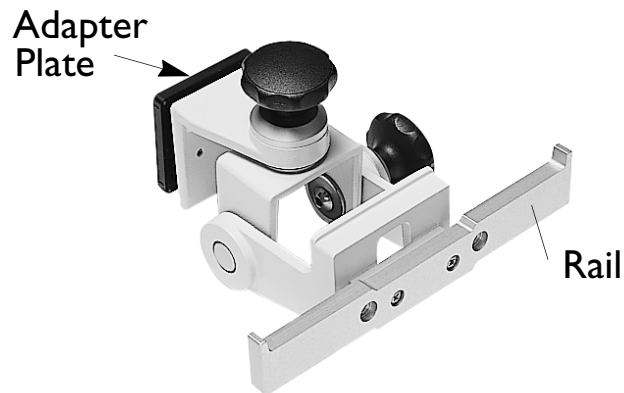

- Step 1** Unpack the Tilt/Swivel mount and check all parts are available.
- Step 2** Remove the adapter plate (this is only necessary for the GCX Wall Channel).
- Step 3** Secure the rail to the Tilt/Swivel mount with the 2 screws provided.
- Step 4** Select 3 screws (appropriate to surface material).
- Step 5** Insert the 3 screws through the screw holes provided in the plate.
- Step 6** Tighten the screws to secure the mount to the wall.
- Step 7** Use adjustment knobs to adjust to the required tilt/swivel angle.

Hang the bed hanger over the rail.

Mounted to the GCX Wall Channel (M3080A #A15)

This option is used to mount the Monitor to a GCX Wall Channel but to also provide tilt and swivel capability.

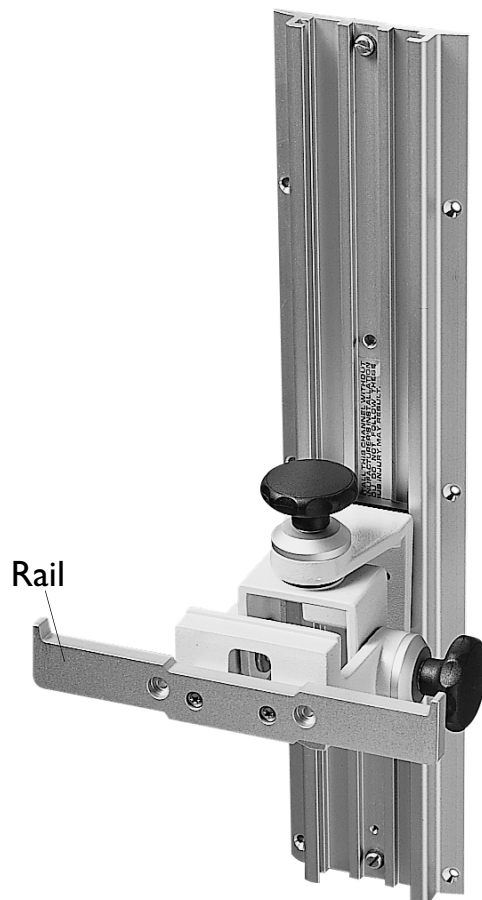

- Step 1** Unpack the Tilt/Swivel mount and check all parts are available.
- Step 2** Make sure the wall channel end-stop has been fitted.
- Step 3** Secure the rail to the Tilt/Swivel mount with the 2 screws provided.
- Step 4** Slide the adapter plate down the wall channel.
- Step 5** Adjust the assembly to the correct height with the adjustable channel stop.
- Step 6** Use adjustment knobs to adjust to the required tilt/swivel angle.

Hang the bed hanger over the rail.

Attached to a Universal Pole Clamp

This option is used to attach the Tilt/Swivel mount to a Universal Pole clamp. The Monitor can then be mounted on a pole or rail and can provide tilt and swivel capability.

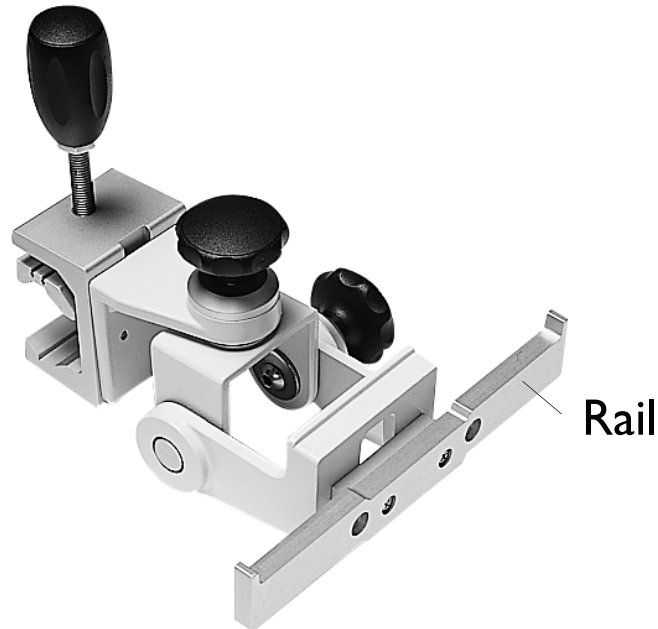

- Step 1** Unpack the Tilt/Swivel mount and check all parts are available.
- Step 2** Remove the adapter plate (this is only necessary for the GCX Wall Channel).
- Step 3** Secure the rail to the Tilt/Swivel mount with the 2 screws provided.
- Step 4** Decide whether the tilt/swivel mounting is to be secured for vertical positioning (on a pole) or for horizontal positioning (on a rail).
- Step 5** Secure the pole clamp to the tilt/swivel mounting with the two screws provided.
- Step 6** Tighten the screws.
- Step 7** Attach the clamp to a pole or rail.
- Step 8** Use adjustment knobs to adjust to the required tilt/swivel angle.

Hang the bed hanger over the rail.

Attached to the Monitor

This option is used to attach the Tilt/Swivel mount directly to the rear of the Monitor. The Monitor can then be mounted on the GCX Wall Channel or can be used together with the Universal Pole Clamp.

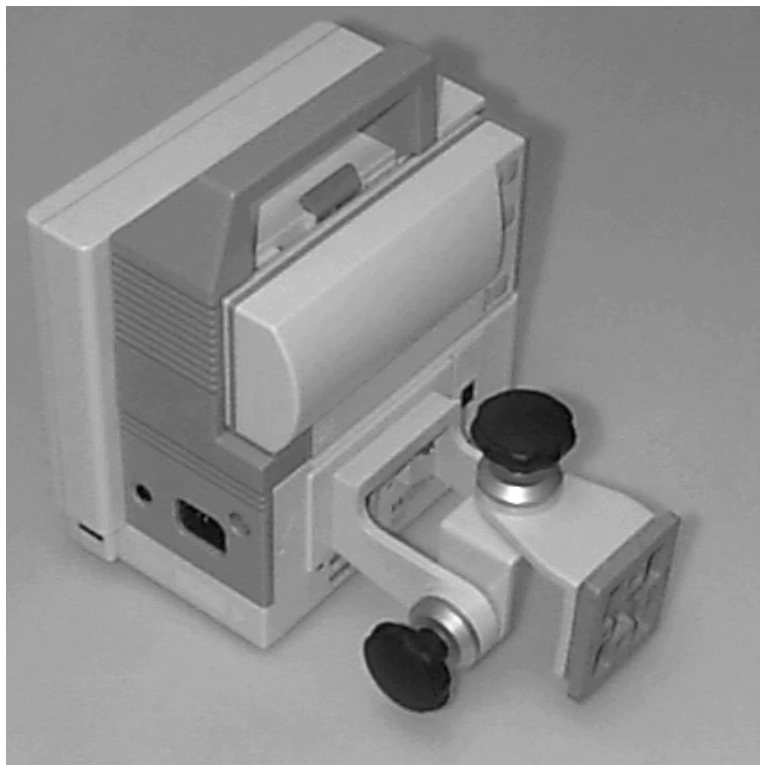

- Step 1** Unpack the Tilt/Swivel mount and check all parts are available.
- Step 2** Secure the tilt/swivel mounting to the Monitor rear panel with the 2 screws provided.
- Step 3** Tighten the screws.

Installing the GCX Wall Channel (M3080A #A15)

This option is the GCX Wall Channel only. To install it, follow the documentation packaged with the channel.

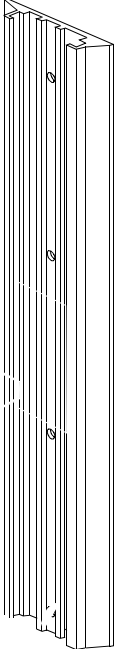

Installing the Universal Pole Clamp (M3080A #C05)

This option is used to mount the Monitor on a pole or rail.



- Step 1** Unpack the clamp and check all parts are available.
 - Step 2** Decide whether the clamp is to be secured for vertical positioning (on a pole) or for horizontal positioning (on a rail). The rear of the Monitor is provided with 4 screw holes to cover both positioning possibilities.
 - Step 3** Secure the clamp to the Monitor with the 2 screws provided.
 - Step 4** Tighten the screws.
- Attach the clamp to the rail or pole as appropriate.

Installing the Measurement Server Mounting Options

To allow the Measurement Server to be mounted remotely from the Monitor, special mounting plates are available. One plate can be used to mount the Server to a wall or other fixture. The second type can be used for vertical or horizontal mounting on a pole or rail.

New mounting plates are supplied with a MSL cable clamp, and are reinforced by a metal plate at the rear. The MSL cable clamp ensures a secure fit between the MSL cable and the mounting plate. **It is important for the customer to decide whether the MSL cable clamp is to be used or not at installation time, as once the decision is taken to fit the clamp, the MSL cable should not be removed from the clamp.**

You **cannot** fit the MSL cable clamp to earlier versions of the mounting plate.

Server Mounting Plate (M3080A #A01)

This option includes a pack of 5 mounting plates. To mount the plate securely, you need two screws per plate. These are not provided because the type of surface dictates the type of screw.

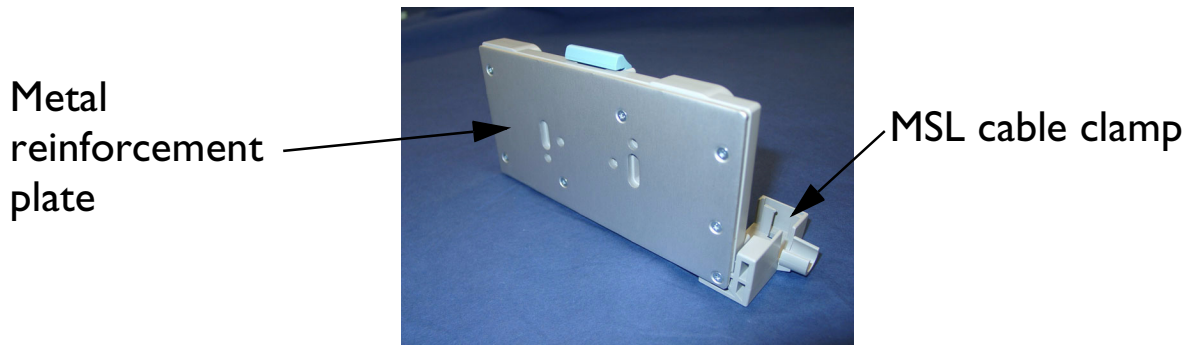

Rear view (new version)

- Step 1** Unpack the plates and check all parts are available.
- Step 2** Select a mounting plate, and if applicable, fit the MSL cable clamp to the mounting plate, using the supplied Torx T-10 screw.

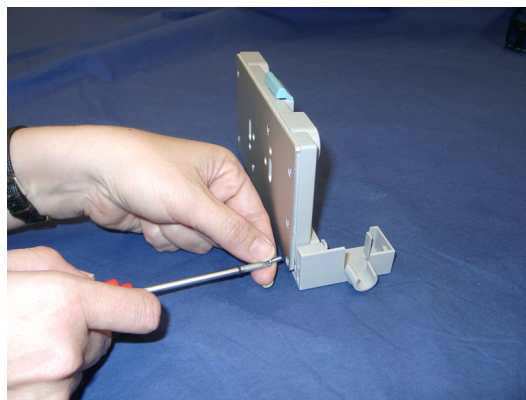

Step 3 Place the cable (1) on the clamp (2), as illustrated. Use the visual guide (3) and the positioning notch (4) to ensure you have the cable correctly positioned.

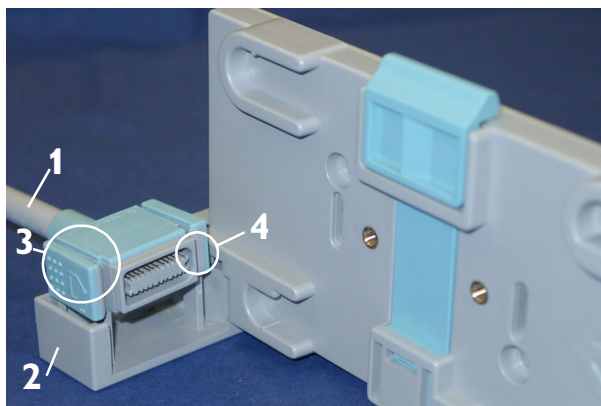

Step 4 Squeeze open the side clips (5) and ease the cable into the clamp so that the clips grip the gray mouldings (6).

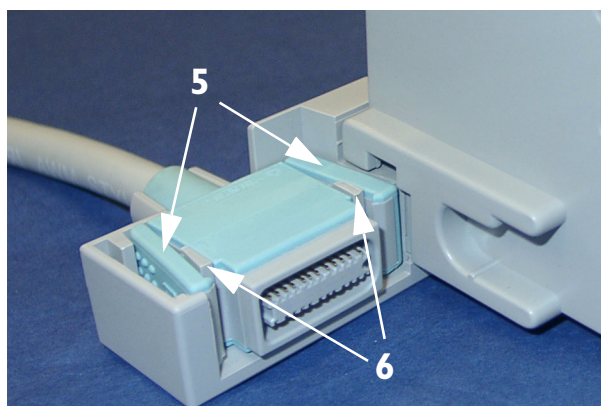

Step 5 Press the cable down firmly to ensure that it is fully seated in the clamp.

NOTE

Once fixed, do not remove the cable from the MSL clamp.

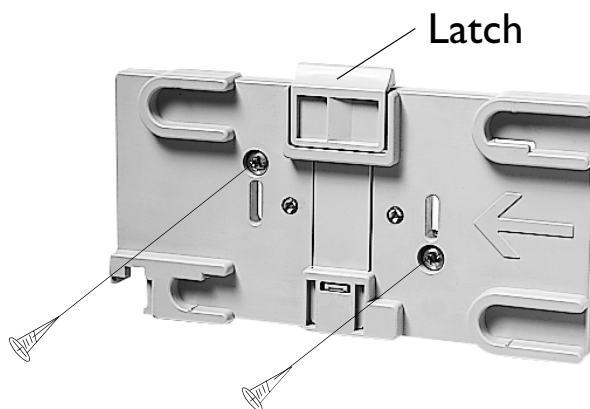

Installing the Measurement Server Mounting Options

- Step 6** Select two screws and suitable fixings appropriate to surface the material. If necessary, mark the screw positions on the surface and drill suitable holes.
- Step 7** Insert the 2 screws through the screw holes provided in the plate.
- Step 8** Tighten the screws.
- Step 9** Align the feet on the MMS with the locating shoes (7) on the mounting plate and slide the MMS onto the mounting plate. The Server snap-fits onto the plate.

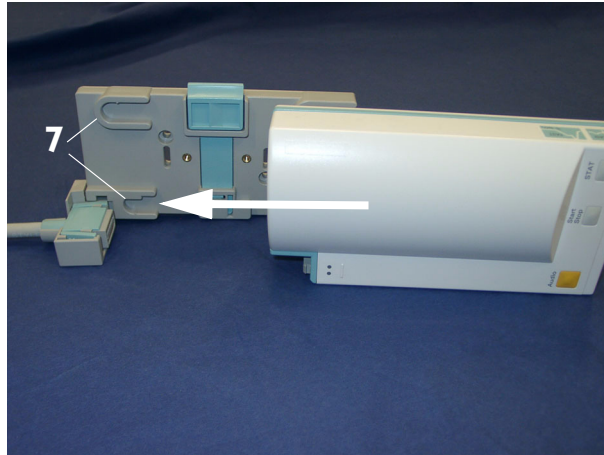

To release the Server, press and hold the latch (in the middle at the top of the mount) away from the Server and slide it out.

Server Mounting Plate (M3080A #A02)

This option is used for mounting the Server on a rail or pole. The rotatable clamp gives 4 fixed positions. It is delivered ready-to-use and does not require installing.

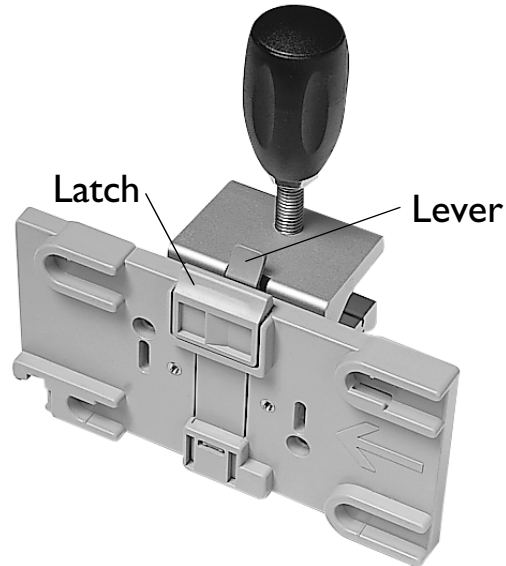

Step 1 Unpack the assembly and check all parts are available.

Step 2 If applicable, fit the MSL cable clamp to the mounting plate, using the supplied Torx T-10 screw, as described for the server mounting plate (M3080A #A02) starting on page 108 (steps 2 to 5).

Step 3 Secure the clamp to a pole or rail.

The Server snap-fits onto the plate. To release the Server, press and hold the latch (in the middle at the top of the mount) away from the Server and slide it out. To rotate the plate, press and hold the lever on the clamp away from plate while rotating the plate.

Mounting Options for the Local Recorder

Two mounting solutions are available for the optional XE-50p strip chart recorder:

- **Roll Stand** including Down-Pole (M3080A #A30)
- **Wall Mount** (M3080A #A31)

Please refer to the installation instructions that accompany the mounting hardware for details of how to mount the recorder.

MSL Cable Termination

The following installation procedure describes how to install the wall installation cable kit when the patient monitor and the measurement server are not located at the same site. The kit consists of two connector boxes and a cable (15m or 25m).

For this procedure you need the Insertion Tool (M3086-43801) and a small screwdriver.

Step 1 Draw the MSL cable through the wall from the site of the monitor to the site of the measurement server.

Each MSL face plate kit contains two connector boxes; one in-going and one out-going. (The US version contains an additional rectangular wall-mounting plate).

NOTE

The installation procedure is the same for both connector boxes. This means you must perform steps 3 to 8 of this procedure twice.

The connectors on each box are different, so you must ensure that the correct box is placed at the correct location. The symbol on the plastic angled cover indicates at which site you should install the box:

Symbol:  is connector box (in) and must be placed at the monitor site.

Symbol:  is connector box (out) and must be placed at the measurement server site.

The correct connector cable (M3081-61601, M3081-61602 or M3081-61603) has the opposite symbol:

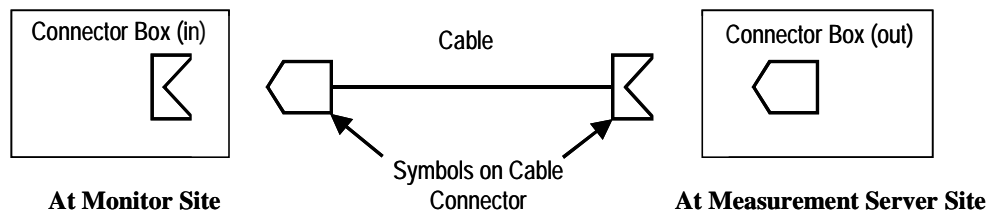

If there are no symbols on the cover, dots are used:

•• ↔ •• and • ↔ •

Step 2 Detach the PCB assembly (in/out) from the metallic mounting flange.

Step 3 Use the Insertion Tool (M3086-43801) to position each wire on the PCB according the following wiring schematic, where each color corresponds to a number.

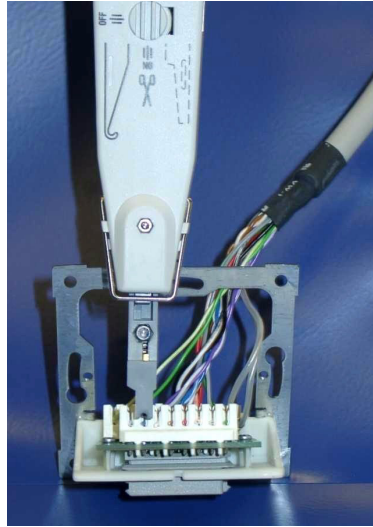

NOTE

The Insertion Tool should be set to cutting mode \times = on. The Insertion Tool automatically removes the insulation at the connection site, clamps the wire in the correct position, and cuts off the excess wire.

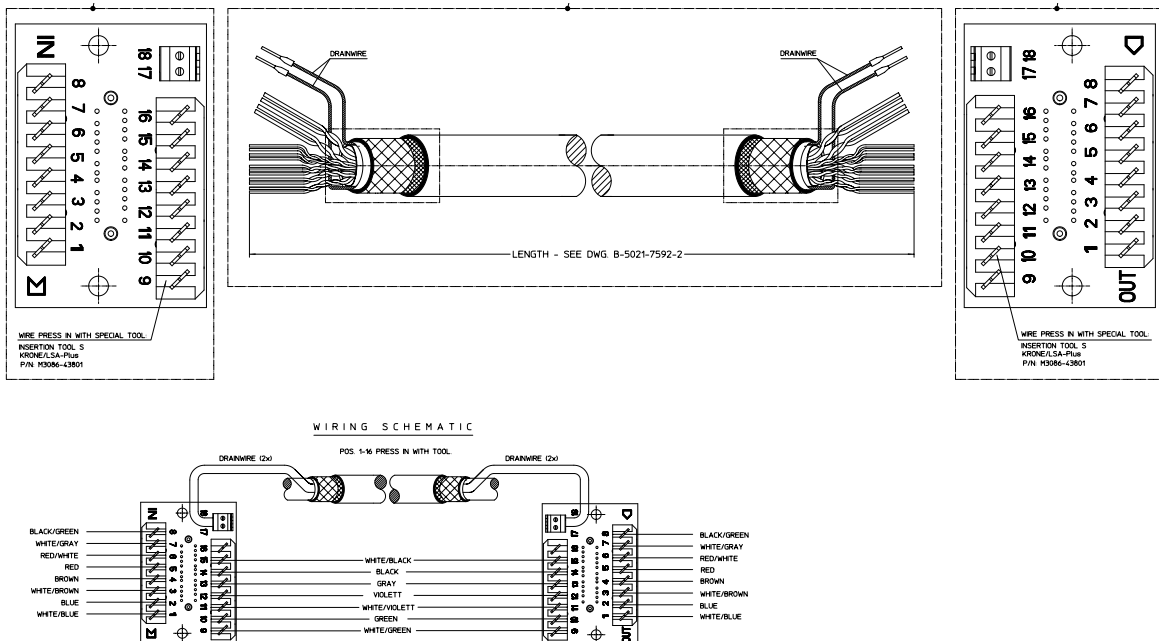

Step 4 Use a small screwdriver to connect the two drain wires to the PCB, see the wiring schematic above.

Step 5 Slide the PCB back on to the metallic mounting flange.

Step 6 Use screws to fasten the mounting flange to the wall.

NOTE

US version only: Fasten the rectangular wall-mounting plate to the wall. Attach the mounting flange to the wall-mounting plate.

Step 7 Mount the plastic cover. The plastic cover consists of two pieces:

Frame

Angled cover

Put the frame over the mounting insert and the PCB. Place the angled cover on top and fasten with two screws.

Step 8 Connect the monitor and the measurement server to the wall installation.

Step 9 Perform the following tests as described in the “Testing the Instrument” section of this manual:

Power-on test blocks

Safety test blocks

ECG Sync Performance Test

Disposing of the Monitor, Measurement Server and Measurement Server Extensions

WARNING

To avoid contaminating or infecting personnel, the service environment or other equipment, make sure the equipment has been appropriately disinfected and decontaminated before disposal.

The battery can be easily removed (see “Maintaining the Instrument” on page 119 as well as the “Using Your Monitor in Patient Transport” chapter in the *Instructions for Use* for information on using batteries), and can be recharged for use with another machine or, when no longer rechargeable, can be returned, free of charge, to the worldwide-recycling program run by the battery manufacturer (contact your local supplier for details).

The Monitor and Measurement Server Extension can be disassembled see “Repairing the Instrument” on page 219.

- There is no metal moulded into the plastic case, and no metal sprays on the plastic.
All plastic parts with a weight greater than 10g (0.35 ounces) are marked with the ISO code for identification.
All labelling on the product has been done by laser printing, so no separation is necessary before recycling.
- The sheet metal card cage uses only one kind of steel.
- The handle is a 2 compound moulding, separable by the application of force.
- The screen has a touch resistor laminate, separable by the application of force.
- User documentation and Service documentation are wire-o bound. The binding is separable by the application of force.
No heavy metals were used in printing the documentation.
- The cardboard and foam used in packaging are 100% recyclable.
No heavy metals were used in printing the packaging.

Tutorial for Installing the Instrument

Question 1: For patient safety, where and how should monitoring equipment be mounted?

- a. Do not mount any portion of monitoring equipment over a patient's bed.
- b. Lead expansion bolts are neither adequate nor safe to use when mounting equipment on plaster board walls.
- c. It is important not to remove the channel safety stop on the GCX Wall Channel while the mount is supporting monitoring equipment.
- d. All of the above examples are correct.

Question 2: When organising power supply for monitoring equipment, which of the following does not contribute to patient safety?

- a. Do not touch the patient when connecting or disconnecting a cable to a Video Out connector.
- b. It is important to read and become familiar with the "Monitor and Measurement Server Specifications" chapter in the *Instructions for Use*.
- c. When connected to an AC power supply (either mains or vehicle), the cabinet of the monitor must be grounded.
- d. If other patient-connected equipment is used simultaneous to the Monitor, the summation of leakage currents can be hazardous to the patient or to hospital personnel.
- e. All of the above examples are correct.

Question 3: How can you eliminate potential differences between different pieces of equipment, for internal examinations on the heart or on the brain?

- a. Do not mount monitoring equipment over the patient's bed.
- b. Connect the Monitor by a separate connection to the equipotential grounding system of the medically-used room.
- c. The Instrument must be kept clear of condensation.
- d. There is nothing in particular that needs to be done.

Answers to the Tutorial for Installing the Instrument

- 1) b. (See page 100 for more details.)
- 2) e. (See entire chapter for more details.)
- 3) b. (See page 65 for more details.)

3 Maintaining the Instrument

Objectives

In order to meet this chapter's objectives, you should be able to perform light maintenance and preventive maintenance for the Monitor, the Measurement Server and, where present, the Measurement Server Extension through the following tasks:

- Inspection of the Instrument.
- Cleaning of the Instrument.
- Replacement of Preventive Maintenance Parts
- Battery Handling, Maintenance, and Good Practices.

This chapter provides an overall maintenance frequency timetable as well as a checklist of maintenance procedures which include, for the sake of completeness, comprehensive reference to the repair procedures found in "Repairing the Instrument" and to the testing procedures found in "Testing the Instrument".

The tests included in "Testing the Instrument" are functionality assurance tests, performance assurance tests (preventive maintenance tests), accuracy and performance procedures, and patient safety checks used to verify that the Instrument is operating properly.

Concepts

Light Maintenance Light maintenance tasks can be defined as those tasks required to maintain the Instrument in clean, functional working order. These include inspection, cleaning practice and battery maintenance as well as the continuous observation of replaceable parts for wear.

Battery Conditioning A rechargeable battery must be conditioned at regular intervals to prepare it for further charge/discharge cycles. Conditioning a battery refers to the complete discharge of a charged battery by allowing it to die out while in non-critical use. The empty battery may then be recharged and put back into use.

Recommendations for Maintenance Frequency

The maintenance checklist appears in the next section of this chapter. The listed procedures should be performed as indicated in the Suggested Maintenance Timetable below. The checklist may be photocopied and should be completed by the maintainer. It should be filed for future reference. The owner of the equipment is responsible for the performance of the maintenance activities in line with the schedule below.

Suggested Maintenance Timetable	Frequency
Inspect the Instrument, and inspect the cables and cords for the entire Instrument.	Daily.
Preventive Maintenance for the M3046A Monitor <ul style="list-style-type: none"> • Cleaning procedures. • Testing Procedures 	<ul style="list-style-type: none"> • Clean as needed. • See "Testing the Instrument".
Preventive Maintenance for the M3000A/M3001A Measurement Server <ul style="list-style-type: none"> • Cleaning procedures. • Non-invasive Blood Pressure Calibration test • Testing procedures. 	<ul style="list-style-type: none"> • Clean as needed. • Once every two years. • See "Testing the Instrument".
Preventive Maintenance for the M3015A Measurement Server Extension <ul style="list-style-type: none"> • Cleaning procedures. • Replace pump and CO₂ scrubber, if required (<i>units with serial number prefix DE020:xxxxx only</i>) • Calibration Procedures • Testing Procedures. 	<ul style="list-style-type: none"> • Clean as needed. • After 15,000 to 20,000 hours of use (max. 20 000 hours) or as needed (typically 3 - 6 years of use). Replace both parts at the same time if both have >15 000 hours of continuous use. • Once a year. • See "Testing the Instrument".
Preventive Maintenance for the M3016A Measurement Server Extension <ul style="list-style-type: none"> • Cleaning procedures. • Testing Procedures. 	<ul style="list-style-type: none"> • Clean as needed. • See "Testing the Instrument".
Battery conditioning (completely discharge the battery)	Approximately every 50 charge/discharge cycles.

Maintenance Checklist

Check Here	Topics in this Chapter	See Page
Inspecting the Instrument		
	Inspect Cables, Cords and Housing	122
Preventive Maintenance Tasks		
	Replacing the Backlight Tube Assembly	123
	M3000A/M3001A NBP Calibration and Performance tests	146
	M3015A	
	<ul style="list-style-type: none"> Replacement of the Pump and CO₂ Scrubber <i>(units with serial number prefix DE020xxxxx only)</i> 	125
	<ul style="list-style-type: none"> Sidestream CO₂ Performance Test 	148
General Cleaning of the Instrument		
	Cleaning Guidelines	125
Battery Handling, Maintenance and Good Practices		
	Checking the Battery Status	127
	Charging the Battery	129
	Conditioning a Battery	130
Instrument Tests for Functionality Assurance, Preventive Maintenance, Performance and Safety Tests		
	Testing the Instrument	137

Inspecting the Instrument

- Step 1** Examine the exterior of the Measurement Server, if present, the Measurement Server Extension, and the Monitor for cleanliness and general physical condition. Ensure that plastic housings are intact, that all hardware is present and tightly-fitted, and that there are no spilled liquids or other serious abuse.
- Step 2** Inspect Server-to-Monitor link for cleanliness and good condition. Ensure that the Measurement Server and/or Measurement Server Extension is locked into place and does not slide out without first releasing the locking plate on the top of the housing.
- Step 3** Ensure all labeling is present and legible.
- Step 4** Inspect all accessories external to the Instrument such as transducers, referring to the manufacturer's documentation. Verify that the backlight tube brightness is adequate. Replace the backlight tube if necessary.

NOTE

Philips recommends replacement of the backlight tube at the latest after 20 000 hours (approximately 3 years) of use.

Inspect Cables and Cords

- Step 1** Examine the line/power plug for damage. Ensure that the prongs of the plug do not move in the casing.
- Step 2** Inspect the line/power cord for signs of damage. If damaged, replace the entire cord. Ensure that any new line/power cord or plug is fitted with the same polarity as the old one.
- Step 3** Inspect the interconnecting cables between the Measurement Server, the Measurement Server Extension and the Monitor for general condition. Clean or replace contacts or housings that are damaged, corroded or dirty. Examine them carefully to detect breaks in the insulation. Ensure that the cable connectors are properly engaged.
- Step 4** Inspect the patient cables and leads and their strain reliefs for general condition. Examine cables carefully to detect breaks in the insulation and to ensure that they are gripped securely in the connectors of each end to prevent rotation or other strain.
- Step 5** Flex the patient cable near each end to verify that there are no intermittent faults.

Preventive Maintenance Tasks

M3046A

Preventive maintenance for the Monitor comprises the following activities:

- Perform visual inspection (see “Inspecting the Instrument” on page 122)
- Replace the Backlight Tube Assembly (if required).

Replacing the Backlight Tube Assembly

The intensity of the fluorescent tube used for backlight illumination of the LCD Display gradually decreases over time. As a result, periodic replacement is necessary.

Philips recommends replacement of the Backlight Tube Assembly after 3 years (20 000 hours) of continuous use or if there is noticeable decrease in the display illumination. (Display illumination decreases by about half after 3 years of continuous use.) The procedure for replacing the Backlight Tube Assembly is found in "Repairing the Instrument".

NOTE

After fitting new tubes, go to Service Mode and reset the Backlight-Tube counter to zero.

M3000A / M3001A

NBP Calibration and Performance tests

The preventative maintenance for the Non-invasive blood pressure measurement consists of the following tests:

- Accuracy Test
- Leakage Test
- Linearity Test
- Valve Test

The tests are described in "Testing the Instrument", see also “NBP Accuracy, Leakage, Linearity and Valve Test” on page 146.

M3015A

NOTE

1. Allow 5 seconds between individual service procedures in order to ensure stable equipment conditions.
2. When certain Monitor procedures are running (for example, AutoZero or purging), service procedures are not possible and trying to start them will result in a message “Service Operation Failed” in the status line on the Monitor. Wait until the Monitor has completed the current operation, then restart the service procedure.

Preventive maintenance comprises the following activities:

- Perform visual inspection (see “Inspecting the Instrument” on page 122)
- Check the operating time for the pump and CO₂ scrubbers (Pump OpTime).
- If required, (operating time >15,000 hours), replace the pump and the CO₂ scrubber (*units with serial number prefix DE020xxxxx only*), and reset the operating time counter.
- Perform barometric pressure check and calibrate, if necessary, see “Barometric Pressure Check and Calibration” on page 149.
- Perform leakage check, see “Leakage Check” on page 150.
- Perform Pump Check
- Perform flow check and calibrate, if necessary, see “Flow Rate Check and Calibration” on page 151.
- Perform Noise Check
- Perform CO₂ calibration check; check the date of the last calibration and calibrate, if necessary, see “CO₂ Gas Measurement Calibration Check” on page 152.
- If calibration done, perform CO₂ calibration verification using 2nd calibration gas
- If M3015A has been opened, perform a system safety test, see “Patient Safety Checks” on page 159.

Tools Required

- Standard tools, e.g. screwdriver, tweezers
- ESD protection equipment
- Electronic flowmeter, M1026-60144
- Gas calibration equipment
 - Cal 1 gas 15210-64010 (5% CO₂)
 - Cal 2 gas 15210-64020 (10% CO₂)
 - Cal gas flow regulator M2267A
 - Cal tube 13907A

Required Replacement Part

- Pump assembly and CO₂ scrubber (M3015-29303)

Replacement of the Pump and CO₂ Scrubber

Replacement of the Pump and CO₂ Scrubber is supported for units with serial number prefix DE020xxxxx only. Where a recommendation is made to replace the Pump and CO₂ Scrubber, this applies only to these earlier units. If the Pump and CO₂ Scrubber are defective in later units with serial number prefix DE435xxxxx, repair is effected by M3015A unit exchange.

The procedure for replacing the Pump and CO₂ Scrubber is found in "Repairing the Instrument".

The effectiveness of the Pump and the CO₂ Scrubber gradually decreases over time. As a result, periodic replacement is necessary.

Philips recommends replacement as follows:

- After 15,000 hours of use (check "Pump Op Time". See "Checking and Resetting Time Counters" on page 153).
- If the Instrument requires repairs, check the time counters, and replace the Pump and CO₂ Scrubber if necessary, in addition to any other repairs.

NOTE

After fitting the new part(s), go to Service Mode and reset the counter for the part(s) you have replaced. The procedure for resetting the counters is found in "Repairing the Instrument".

When the PumpOpTime has been reset an INOP will be generated: "CO₂ OCCLUSION". To clear this INOP you must perform a flow check and store the flow in Service Mode (select "Store Flow").

Replacement of the Infrared Lamp

The infrared lamp can be exchanged only in units with serial number prefix **DE020xxxxx** manufactured before June 2002. The support strategy for later units in case of an infrared lamp failure is M3015A unit exchange.

General Cleaning of the Instrument

The Monitor, the Measurement Server, and the Measurement Server Extension should be kept free of dust and dirt. In particular, exterior cleaning of the Monitor's case and LCD screen is recommended. Clean the case with a lint-free cloth or sponge, moistened with either soap and water, a diluted non-caustic detergent or one of the cleaning agents listed in this chapter. Universal Display Cleaner or window cleaner is recommended for the cleaning of the LCD screen.

Full cleaning instructions are given in the *Instructions for Use*.

Cleaning Guidelines

To avoid damage to the Instrument, follow these cautionary guidelines:

General Cleaning of the Instrument

- Do **NOT** use any Povodine, Sagrotan, Mucocit cleaning agents or strong solvents, for example, acetone or Kohrsolin.
- Dilute cleaning agents—Most cleaning agents must be diluted before use. Always dilute according to the manufacturer’s instructions.
- Never use abrasive materials, such as steel wool or silver polish.
- Do not allow any liquid to enter the case. Never submerge any part of the Instrument.
- Do not pour liquid onto the Instrument during cleaning.
- Do not allow any cleaner to remain on any of the equipment surfaces. Wipe cleaners off immediately.

Cleaning Agents

Any solution categorized under the following generic products, apart from those listed in the cautionary guidelines above, can be used as a cleaning agent:

- Dilute ammonia
- Dilute formaldehyde 35-37%.
- Hydrogen peroxide (3%).
- Ethyl alcohol.
- Isopropyl alcohol.
- Dilute sodium hypochlorite (laundry bleach).

NOTE

Concentrations ranging from approximately 500 ppm sodium hypochlorite (1:100 dilution of household bleach) to 5000 ppm sodium hypochlorite (1:10 dilution of household bleach) are effective depending on the amount of organic material (e.g. blood, mucus) present on the surface to be cleaned and disinfected.

Philips makes no claims regarding the efficacy of these chemicals or this method as means for infection control. Consult your hospital’s Infection Control Officer or Epidemiologist.

For comprehensive details on cleaning agents and their efficacy, refer to “Guidelines for Prevention of Transmission of Human Immunodeficiency Virus and Hepatitis B Virus to Health Care and Public-Safety Workers.” issued by the U.S. Department of Health and Human Services, Public Health Service, Centers for Disease Control, Atlanta, Georgia, February 1989.

Battery Handling, Maintenance and Good Practices

This section provides some information on how to handle and maintain the battery in order to get the best usage from it. Additionally, some good working practices are also given regarding the correct disposal of the battery.

About the Battery

The rechargeable battery used in the Monitor is regarded as a *Smart* battery because it has built-in circuitry. (This circuitry communicates battery-status information to the Monitor.)

NOTE

If an unused battery does not communicate (the LEDs do not light), a MALFUNCTION message will appear when it is inserted in a monitor. In this situation it means that the smart battery is really empty and cannot communicate. Normally the battery is in good order and the message will disappear after 5 to 10 minutes of charging.

To get the most out of a battery, observe the following guidelines:

- **IMPORTANT! Leaving the battery in a monitor running on AC mains power will shorten the life of the battery. ALWAYS remove the battery from the monitor when it is not being used regularly as the main source of power for the monitor.** Recharge the battery every 3 to 4 months.
- The shelf-life of a fully charged battery is about 6 months.
- Once a battery has been activated, keep it charged. If it is not in use, recharge it every 3 to 4 months.
- Condition the battery approximately every 50 recharge cycles.
- **If the battery shows damage or signs of leakage, replace it immediately. Do not use a faulty battery in the Monitor.**
- Charging rate of the battery:
 - Monitor Off: 1.4 Amps.
 - Monitor On: 200 mAmps.
- **Battery maintenance** - We recommend you use the external Battery Charger and Conditioner (M8043A) to maintain and condition your batteries.
- **Battery disposal** - Batteries should be disposed of in an environmentally-responsible manner (see also page 115). Consult the hospital administrator or your local Philips representative for local arrangements.
 - Do not dispose of the battery in normal waste containers.**

Checking the Battery Status

When the Monitor is connected to the AC mains power supply, the battery charges automatically. The battery can be charged externally from the Monitor by using the Battery Charger and Conditioner (M8043A).

Battery status (level of charge) is indicated several ways:

- LEDs on the front panel of the Monitor.
- Battery gauge.
- Battery status menu.
- INOP messages.

The AC Power LED is only on when the power cord is connected and AC power is available to the Monitor. In this case, the battery can be either charging or fully charged.

The battery LED can be green, yellow, or red depending on the following conditions:

AC power	Yes		No	
	on	off	on	off
standby switch	on or off		on	off
battery full ^a (no charging)	green		off	off
battery charging	yellow		not applicable	not applicable
replace battery ^b (>= 5 minutes of operation left)	not applicable		1.5 red flashes per sec.	off
battery empty	yellow		red flash if On-Off / Standby is pressed. ^c	off
no battery	off		off	off
battery malfunction	every 2 second briefly off		red flash if On-Off/ Standby is pressed ^c	off

a. Relative state of charge.

b. Battery voltage less than 11.5V.

c. Restart is attempted if V_{bat} > 11.5V and battery is not registered as being empty or having a malfunction.

If the remaining battery-operating time is only 5 minutes, the LED flashes red at a repetition rate of 1.5 flashes per second.

When the battery is empty, the Monitor switches off automatically (including the green On-Off/Standby LED on the front panel). This switch-off event is memorized together with the serial number of the battery. A restart of the Monitor with this battery is inhibited to prevent deep discharge. Attempts to restart the Monitor (by pressing the On-Off/Standby) causes the red LED to emit a single flash. (The flash may have a delay of up to 2.5 sec after pressing the On-Off/Standby key). Exchanging the battery causes one of the following to happen:

- If the new battery is partly or fully loaded, the Monitor starts operating.
- If the new battery is empty:
 - If the battery voltage (no load) is below 11.5V, a single red flash is emitted (assuming that there is still enough power to emit this single flash).
 - If the battery voltage is higher than 11.5V (no load) the Monitor tries to restart. If the battery voltage falls below 10.5 V during charging, the Monitor registers the battery as empty, and the Monitor switches off automatically. Any attempt to restart the Monitor (by pressing the On-Off/Standby) causes the red LED to emit a single flash. No more restarts can be attempted with this battery.

Charging the Battery

Battery charging should be done in stable temperature conditions within the range 0... 35°C in order to ensure correct and full loading of the battery.

Battery status is displayed by the battery gauge in the bottom right corner of the resting display. The inner white bar shows the charge status of the battery. The longer the bar, the more charge there is in the battery.

NOTE

The battery gauge shows the charge status of the available capacity remaining in the battery. It **does not** indicate the condition of the battery. For example, for an older battery with an available capacity of only half of its original, theoretical capacity, the battery gauge will indicate a “full” charge status after a charge cycle. **Whenever you need to rely on accurate indication of battery operating time, access the Battery Status Window and check the TimeToEmpty field** (see “Accessing the Battery Status Window” on page 132).

High level
of charge

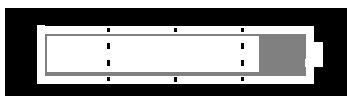

Low level
of charge



If the battery is empty, the inner bar is gray.

If the Monitor cannot access the battery (because of a battery or hardware malfunction) the text string `Malfunction` is displayed on a black background inside the battery gauge and a severe INOP alarm is issued.



Battery conditioning is necessary when the text string `Condit. Battery` is displayed:



In this case, we recommend you remove the battery from the monitor and replace it with a different battery. Condition the battery you removed. The gray bar indicates how much operating capacity remains in the battery, even if it requires conditioning.

You can also charge the battery using an external Battery Charger and Conditioner (M8043A). Refer to the documentation that accompanies the charger for details on charger use.

Conditioning a Battery

What is Battery Conditioning?

Battery conditioning recalibrates the battery to ensure that it has accurate information on the actual battery capacity.

Why is Battery Conditioning Necessary?

The capacity of a battery decreases gradually over the lifetime of a battery. Each time a battery is charged its capacity decreases slightly. Therefore, the operating time of a monitor running off the battery also decreases with each charge cycle.

Battery conditioning ensures that the value stored in the battery for its full capacity takes account of this decrease, so that the remaining battery charge can be calculated accurately, and the low battery warning given at the right time.

When Should Battery Conditioning be Performed?

Battery conditioning should be performed:

- Every 50 charge/discharge cycles, or every three months, whichever comes first.
- When indicated by the Battery Status.

What Causes the Conditioning Message on the Monitor?

In addition to the value for the full capacity, the battery also stores a value for the Max Error. The Max Error tracks the maximum possible deviation of the estimated charge of a battery from the actual charge.

If a battery is charged or discharged partially, or if it is charged while the monitor is being used, the accuracy of the “reference points” for the fully discharged and fully charged states decreases, causing an increase in the value for the Max Error (see diagram, below).

When the Max Error is greater than 20%, a message is displayed prompting the user to condition the battery, as described in “Conditioning a Battery Using the Monitor” on page 131.

WARNING

Never use a monitor that is monitoring a patient to perform battery conditioning.

You can reset the value for the Max Error before the battery needs conditioning, by discharging the battery completely and then recharging it in a monitor that is plugged in but turned off. A conditioning message may also appear if the battery has been stored in a monitor that has not been in use for several weeks. Refer to “Conditioning a Battery” on page 130.

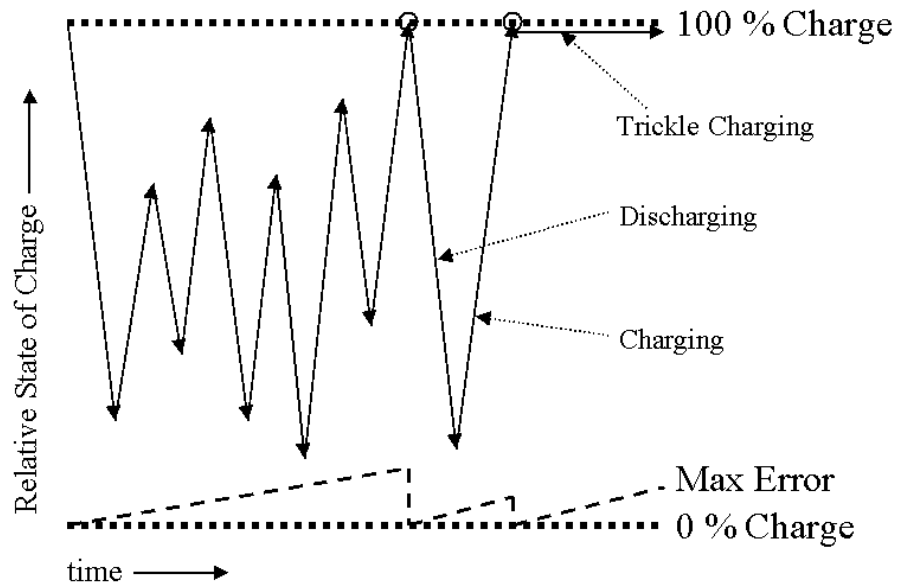

Conditioning a Battery Using the Battery Charger and Conditioner (M8043A)

We recommend you use the Battery Charger and Conditioner (M8043A) for all your battery maintenance needs. The M8043A analyses the battery status, and then charges and/or conditions the battery automatically as required, with no input from the user necessary. You can also start a conditioning cycle manually. After a conditioning cycle, the charger monitors the remaining battery capacity and indicates the status of the battery. Refer to the documentation that accompanies the charger for details on charger use.

You can leave batteries in the Battery Charger and Conditioner (M8043A), as no trickle charging takes place.

Conditioning a Battery Using the Monitor

If you do not have access to a Battery Charger and Conditioner (M8043A), you can condition the batteries using the monitor.

We recommend two full charge and discharge cycles to ensure proper conditioning, independent of the initial condition of the battery.

If you need to continue battery powered monitoring, replace the battery in the monitor with a different charged and conditioned battery. **Do not** condition a battery in a monitor that is being used on patients.

- 1 Insert the battery that is to be conditioned into a monitor that is not currently being used.
- 2 Disconnect the monitor from the AC power supply.

- 3 Turn on the monitor, and leave it on until it switches off automatically.
- 4 Turn the monitor off using the **On/Off/Standby** switch.
- 5 Reconnect the monitor to the AC power supply.
- 6 Charge the battery until it is full (the battery LED on the monitor is green).
- 7 Repeat steps 2 to 6.

A Note on Trickle Charging

Trickle charging means a low current is applied to a fully charged battery to keep the charge at 100%. (The self-discharge of NiMH batteries is in the range of 20-25% per month!).

Trickle charging accelerates the aging of the battery and is not recommended for batteries that are only used occasionally. In such cases the battery should be kept separate from the monitor and charged every three to four months to prevent deep discharge. Deep discharge occurs when the battery has a relative state of charge of 0%.

NOTE

If you cannot avoid trickle charging, use the Battery Charger and Conditioner (M8043A) to recondition the battery once a month. See the instructions that accompany the charger for details on charger use.

Trickle charging only takes place for batteries stored in a monitor connected to AC mains. You can leave batteries in the Battery Charger and Conditioner (M8043A), as no trickle charging takes place.

Accessing the Battery Status Window

The Battery Status window shows additional information about the battery. To access this window, press the Setup key on the front panel and select Battery from the list. The Monitor displays a screen similar to the following:

```

Battery Status
Duracell TR36 12.0V SN 00292 07JUL98 SBM 1.0
TimeToEmpty: 112 min +/- 10%(est. 1 min avg)
Capacity      Current      : 284.0 mAh
remaining    : 1247 mAh Voltage     : 12.9 V
fullCharge   : 1852 mAh Temperature: 23.0 C
designed     : 2400 mAh Cycles       : 234
Exit
    
```

The meaning of the messages are described in the following paragraphs.

Time to Empty—This refers to the approximate (+/- 10%) battery-usage time remaining in the battery. The number is based on the average monitor-loading during the previous minute.

Time to Full—This refers to the approximate (+/- 10%) time remaining to fully charge the battery. The number is based on the average monitor-loading during the previous minute.

When the Time-to-Full shows 0, the battery-charge LED on the front panel remains lit until battery calibration is complete.

Battery INOP Messages

The following battery-related INOP messages are issued by the Monitor. All INOPs continue until the Monitor is plugged into the AC power or the INOP condition is fixed.

BATTERY LOW—This is a hard INOP which indicates that the remaining battery-operating time is less than approximately 20 minutes.

BATTERY EMPTY—This is a hard INOP which indicates that the *resting-state* operating time for the Monitor is guaranteed for a further 5 min only (this information is derived from the voltage of the battery). The battery LED blinks at a rate of 1.5 red flashes per second. A severe INOP switches the main alarms-suspended status back to on, and generates an INOP alarm. If this alarm is silenced, it recurs after 3 minutes.

The previous two INOPs are cleared if AC power is connected, while the following INOP stays no matter whether AC power is connected.

BATTERY MALFUNCTION—This is a severe INOP which indicates a malfunction of the hardware or the battery. A severe INOP switches the main alarms-suspended status back to on, and generates an INOP alarm. If this alarm is silenced, it recurs after 3 minutes.

NOTE

If this INOP occurs after a new battery has been inserted, it may indicate the battery cannot yet communicate because it is still too deeply discharged. In this case the message will disappear after 5 to 10 minutes of charging.

Tutorial for Maintaining the Instrument

Question 1: What is battery conditioning and how often must it be performed?

- a. Conditioning a battery refers to the complete discharge of a charged battery by allowing it to die out while in non-critical use. The empty battery may then be recharged and put back into use. The battery used in the Instrument cannot be conditioned. Discard it after use.
- b. Conditioning a battery refers to the complete discharge of a charged battery by allowing it to die out while in non-critical use. The empty battery may then be recharged and put back into use. The rechargeable battery used in the Instrument must be conditioned every 10 cycles to prepare it for further charge/discharge cycles.
- c. A rechargeable battery must be conditioned at regular intervals to prepare it for further charge/discharge cycles. Conditioning a battery refers to the complete discharge of a charged battery by allowing it to die out while in non-critical use. The empty battery may then be recharged and put back into use. The rechargeable battery used in the Instrument must be conditioned every 50 cycles to prepare it for further charge/discharge cycles.

Question 2: According to this chapter, which of the following statements are part of inspecting the Instrument?

- a. Replaceable parts should be monitored for duration of continuous use. After approximately 15,000 hours of continuous use, the parts should be replaced.
- b. All cables and cords should be inspected for damage and wear on a daily basis.
- c. All Instrument labeling should be present and legible.
- d. All of the above statements are correct according to this chapter.

Question 3: Which of the following cleaners are acceptable for cleaning the Instrument?

- a. Dilute ammonia, dilute sodium hypochlorite, dilute formaldehyde (35-37%), hydrogen peroxide (3%), ethyl alcohol, and isopropyl alcohol
- b. Steel wool.
- c. Povodine, Sagrotan, and Mucocit cleaning agents and acetone.

Answers to the Tutorial for Maintaining the Instrument

- 1) c. (See pages 119 and 127 for more details.)
- 2) d. (See page 122 for more details.)
- 3) a. (See pages 125 and 126 for more details.)

4 Testing the Instrument

Objectives

In order to meet this chapter's objectives, you should be able to test the Monitor, the Measurement Server and, where present, the Measurement Server Extension through the following types of tests:

- Performance Assurance Checks and Tests.
- Accuracy, Calibration and Performance Procedures.
- Patient Safety Checks.

This chapter provides a checklist of testing procedures for the Measurement Server, the Measurement Server Extensions and the Monitor.

For inspection procedures; preventive maintenance procedures; cleaning procedures; and battery handling, maintenance, and good practices used to maintain the Instrument in good working order, see "Maintaining the Instrument".

Concepts

- Functionality Assurance** This refers to the combined Performance Assurance Test and Functionality Testing Procedures to be found in this chapter. These tests verify correct Instrument function in general terms.
- Preventive Maintenance** Preventive Maintenance refers specifically to the service calibration tests required to make sure the Instrument measurement results are accurate. When authorized Philips personnel service the Instrument, they report these results back to Philips. The collected data forms a database to be used in product development. These specific tests are required for the NBP parameter and for the sidestream CO₂ parameter. It is not necessary, however, for hospital personnel to report results.
- Performance & Safety Tests** This concept refers to all the remaining accuracy and performance tests available on the Instrument including safety tests and checks for the Instrument.

Test Reporting

The following table shows what must be recorded on the Service Record after completing the tests in this chapter.

Test	What to record
Visual	V:P or V:F
Power On	PO:P or PO:F
P NIBP	PN:P/X1/X2/X3/X4 or PN:F/X1/X2/X3/X4
P CO ₂	PCO2:P/X1/X2/X3/X4/X5/X6/X7/X8 or PCO2:F/X1/X2/X3/X4/X5/X6/X7/X8
Safety	S(1):P/x1/x2 or S(1):F/x1/x2 S(2): P/x1 or S(2): F/x1 S(3): P/x1 or S(3): F/x1

Where P = Pass, F = Fail and X/x are the measured values as defined in the tests described in this chapter

Test Map

The test map shows which tests are required in which situations.

Service Event (When performing...)	Test Blocks RequiredComplete these tests)
Installation of M3/M4 with no display connected to the VGA output	Perform Visual and Power On test blocks
Installation of M3/M4 with a display connected to the VGA output	Perform Visual, Power On and Safety (1) test blocks
Installation of M3/M4 with a recorder connected to the serial interface	Perform Visual, Power On and Safety (1) test blocks. Perform test print on recorder.
Repairs where the power supply in the M3/M4 is replaced	Perform Power On and Safety (2) Test blocks
Repairs where the monitor has been dropped	Perform Power On and Safety (2) and (3) Test blocks
All other M3046A repairs, Hardware or Software Upgrades	Perform Power On test block
Preventative Maintenance	Perform all Preventative Maintenance Tests
Safety and Performance	Perform all Safety and Performance Test blocks.

Testing Checklist

Check Here	Topics in this Chapter	See Page
Functionality Assurance Tests		
	Performance Assurance Test	143
	Quick System Check	143
	System Self-Test	144
Preventive Maintenance Tests		
	NBP Accuracy, Leakage, Linearity and Valve Test	146
	Sidestream CO2 Performance Test	148
Accuracy and Performance Procedures		
	Temperature Accuracy	155
	ECG/Resp Performance	155
	Invasive Pressure Performance Test	156
	SpO2 Performance Test	157
	Mainstream CO2 Performance Test	157
	Nurse Call Relay Performance Test	157
	ECG Sync Performance Test	158
Patient Safety Checks		
	S(1) Part 1: System Enclosure Leakage Current - NC (normal condition)	160
	S(1) Part 2: System Enclosure Leakage current - Single Fault (open earth)	160
	S(2) Protective Earth Continuity	161
	S(3) Patient Leakage current - Single Fault Condition (S.F.C.) mains on applied part	162

Serial Numbers

When recording test results, these are always associated with a particular instrument by means of the serial number. The serial numbers for the Monitor and the Measurement Server can be seen in the “Revisions” window (press Setup key then select “Revisions”). However, if a Measurement Server Extension (M3015A or M3016A) is in use, the number will not appear and must be noted down from the back of the Extension. To do this, remove the Measurement Server and Extension from the Monitor, so that the back of the extension is visible.

Passwords

The following table show the passwords you need to enter to access the different modes. Go to Operating Modes and use the TouchStrip to specify the password. Press OK:

Demo	Config	Service
42351	13251	25531

Visual Test

Inspect the system for obvious signs of damage. Also check external leads and accessories.

What to record on the service record:

V:P or V: F

where P=pass, i.e. the system has no obvious signs of damage
and F=fail

Power On Test

Step 1 Switch on the monitor and connect the Measurement Server to the M3046A

Step 2 Observe whether the monitor boots up successfully without displaying an error code and if an ECG wave appears on the screen.

What to record on the service record:

PO:P or PO:F

where P=pass, i.e. the monitor boots up displaying no error codes and displays an ECG wave and F=fail

Functionality Assurance Tests

The following functionality assurance checks are recommended to verify proper operation daily before the Instrument is used to Monitor a patient:

Functionality assurance checks fall into two parts:

- 1 Verification of overall operation by completing the Performance Assurance Test.
- 2 Verification of the Measurement Server and, where present, the Measurement Server Extension operation by completing the System Check and the System Self-Test.

You can perform these checks in any order you choose. They are divided up here for organizational purposes.

Performance Assurance Test

To verify your Instrument works properly, perform the following test:

- Step 1** Connect the power cord to the Monitor and plug it into an AC power source. Switch the Monitor on by pressing the ON/OFF button.
- Step 2** After approximately one minute, the Monitor should complete its boot-up process. Observe that there is a screen display and that no error codes are displayed.
- Step 3** If any error codes are displayed or the screen remains black, refer to "Troubleshooting the Instrument".

The Instrument has a Self-Test routine which generates and displays test waveforms and corresponding numerics for the Measurement Server and/or Measurement Server Extension that is connected. The test signals are displayed for about 30 seconds and then the display returns to monitoring mode.

The test signal will display only if the system Self-Test is successful and the Measurement Server and, where present, the Measurement Server Extension is plugged into the Monitor. Perform the following quick system check to verify that the System Board and the Measurement Server and, where present, the Measurement Server Extension are communicating properly.

Quick System Check

You can verify that the System Board in the Monitor and Measurement Server and, where present, the Measurement Server Extension are communicating properly by completing the following test.

The Test—Press the **Setup** button, move the highlight to **ECG**, and press on the TouchStrip.

The Result—The ECG window should appear verifying that the System Board and Measurement Server are communicating with each other.

System Self-Test

CAUTION

The Self-Test ensures that the Instrument is functioning correctly; it does not test the accuracy of the Server or the Extension

Step 1 Make sure the Measurement Server is connected to the Monitor, and the Monitor is switched on. (For SpO₂, mainstream CO₂, Pressure, or Temperature, an appropriate transducer must be plugged into the Measurement Server – or, for mainstream CO₂, the Measurement Server Extension – in order to get a test reading. For sidestream CO₂, appropriate tubing must be plugged into the Measurement Server Extension in order to get a test reading.)

Step 2 Press the **Setup** button.

Step 3 Move the highlight to **Test Signals**.

Step 4 Press on the TouchStrip and observe the display. An example test looks similar to the following illustration (the shape of the test signals depends on the selected filter mode).

As well, the table on the following page lists Self-Test values.

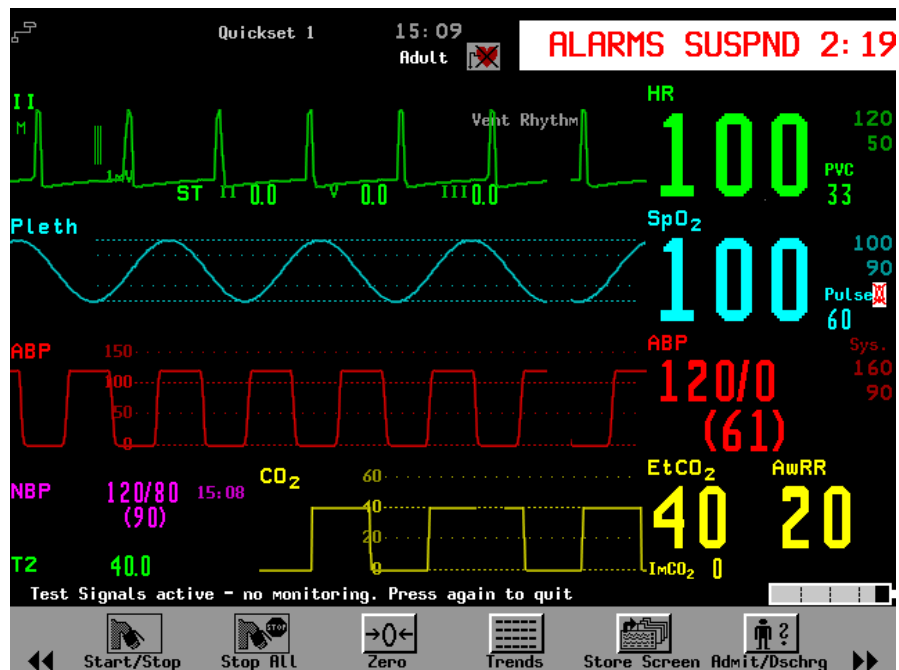

System Self-Test Values

Module	Test Numeric Limits	Test Waveform
ECG and ECG/ Resp	ECG 100 bpm in ADULT mode 125 bpm in NEO/PEDI mode Resp 15 rpm in ADULT mode 30 rpm in PEDI mode 55 rpm in NEO mode	Simulated squarewave and numeric Simulated Resp wave and numeric
Pressure ^a	Systolic 120 mmHg ADULT 60 mmHg PEDI/NEO Diastolic 0 mmHg ADULT/PEDI/ NEO	Simulated squarewave and numerics
SpO ₂ /Pleth ^a	SpO ₂ 100% Pleth Wave on display	Numeric only Simulated wave
Temperature ^a	40 °C (104 °F)	Numeric only
Pleth Pulse Rate	60 bpm in ADULT/NEO mode	
NBP	120/80 (90) ADULT 100/60 (80) PEDI 80/50 (60) NEO	Simulated squarewave and numerics
Sidestream CO ₂ ^b	EtCO ₂ 40 mmHg ImCO ₂ 0 mmHg AWRR 20 rpm	Simulated squarewave and numerics
Mainstream CO ₂ ^a	EtCO ₂ 40 mmHg ImCO ₂ 0 mmHg AWRR 20 rpm	Simulated squarewave and numerics

- a. An appropriate transducer must be plugged into the Server or Server Extension in order to get the test reading.
- b. Appropriate tubing must be plugged into the Server Extension in order to get the test reading. When in Neonatal mode the test signals are switched on, a “CO₂ Equip. Malf.” message will appear until the test signals are switched off; no action is required.

Preventive Maintenance Tests

Preventive Maintenance refers specifically to the series of tests required to make sure the Instrument measurement results are accurate. When authorized Philips personnel service the Instrument, they will report these results back to Philips. The collected data forms a database to be used in product development. The measurements requiring these reported tests are NBP and sidestream CO₂. It is not necessary, however, for hospital personnel to report these results.

NBP Accuracy, Leakage, Linearity and Valve Test

NBP Accuracy Test

This test checks the performance of the non-invasive blood pressure parameter. The NBP accuracy test is required once every two years and when the Instrument is repaired or when Instrument parts are replaced.

Connect the equipment as shown in the following:

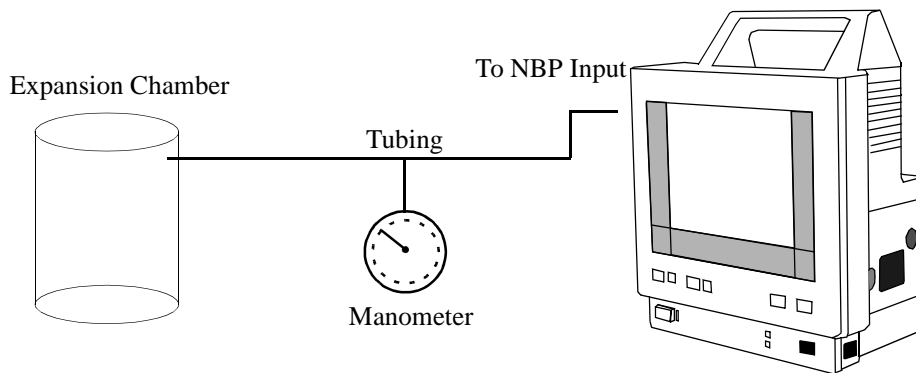

Tools required

- Reference manometer (includes hand pump and valve), accuracy 0.2% of reading.
- Expansion chamber (volume 250 ml +/- 10%). (Or alternatively, an NBP cuff can be used. When using a cuff, take care not to move it or touch it during the procedure as this can cause the calibration to fail.)
- Appropriate tubing.

NOTE

In Service Mode, the systolic and diastolic readings indicate the noise of NBP channels one and two respectively. When static pressure is applied, the reading in NBP channel 1 should be below 50. The value in parentheses indicates the actual pressure applied to the system.

Step 1 Connect the manometer and the pump with tubing to the NBP connector on the Measurement Server and to the expansion chamber.

Step 2 Go to Service Mode.

Step 3 Select the NBP setup.

- Step 4** Select “Close Valves: On”
- Step 5** Raise the pressure to 280 mmHg with the manometer pump.
- Step 6** Wait 10 seconds for the measurement to stabilize.
- Step 7** Compare the manometer values with the displayed values.
- Step 8** Document the value displayed by the M3046A (x1).
- Step 9** If the difference between the manometer and displayed values is greater than 3 mmHg, calibrate the Server. If not proceed to the Leakage test.
- Step 10** To calibrate, select “Close Valves off” then “Calibrate NBP” and wait for the Instrument to pump up the expansion chamber.
- Step 11** When pumping has stopped, wait a few seconds until “EnterPrVal” is highlighted and then move the cursor to the value shown on the manometer.

NOTE

If one of the following prompt messages appears during this step, check whether there is leakage in the setup:

- NBP unable to calibrate—cannot adjust pressure
- NBP unable to calibrate—unstable signal

- Step 12** Press Confirm.

NOTE

If the INOP NBP Equipment Malfunction message occurs in Monitoring Mode, go back to Service Mode and repeat the calibration procedure.

NBP Leakage Test

This test checks the integrity of the system and the valve. The NBP leakage test is required once every two years and when the Instrument is repaired or when Instrument parts are replaced.

- Step 1** If you have calibrated, repeat steps 2 to 6 from the Accuracy test procedure so that you have 280 mmHg pressure on the expansion chamber.
- Step 2** Watch the pressure value for 60 seconds.
- Step 3** Calculate and document the leakage test value (x2).
 $x2 = P1 - P2$
 where P1 is the pressure at the beginning of the leakage test and P2 is the pressure displayed after 60 seconds.
 The leakage test value should be less than 6 mmHg.

NBP Linearity Test

- Step 1** Reduce the manometer pressure to 150 mmHg.
- Step 2** Wait 10 seconds for the measurement to stabilize.
- Step 3** After these 10 seconds, compare the manometer value with the displayed value.
- Step 4** Document the value displayed by the M3046A (x3)
- Step 5** If the difference is greater than 3 mmHg, calibrate the Server (see steps 10 to 12 in the Accuracy Test procedure).

Valve Test

- Step 1** Raise the pressure again to 280 mmHg.
- Step 2** Select “Close valves: Off”.
- Step 3** Wait 5 seconds then document the value displayed. The value should be less than 10 mmHg.
- Step 4** Document the value displayed by the M3046A (x4).

Test	Expected test results	What to record on the Service record
Accuracy test	x1 = value displayed by M3046A Difference \leq 3mmHg	
Leakage test	x2 = leakage test value x2 < 6 mmHg	
Linearity test	x3 = value displayed by M3046A Difference \leq 3mmHg	
Valve Test	x4 = value < 10 mmHg	PN:P/x1/x2/x3/x4 or PN:F/x1/x2/x3/x4 where P = Pass and F = Fail

Sidestream CO₂ Performance Test**NOTE**

- Allow 5 seconds between individual service procedures in order to ensure stable equipment conditions.
- When certain Monitor procedures are running (for example, AutoZero or purging), service procedures are not possible and trying to start them will result in a message “Service Operation Failed” in the status line on the Monitor. Wait until the Monitor has completed the current operation, then restart the service procedure.

This test checks the performance of the CO₂ measurement for the sidestream Extension. The CO₂ performance test is required once per year and when the Instrument is repaired or when parts are replaced.

This test uses calibration equipment that can be ordered (see "Replacement Parts" for the part number). The procedure is summarised in the following steps. Refer to the documentation accompanying the equipment for detailed instructions.

Tools Required

- Standard tools, e.g. screwdriver, tweezers
- Electronic flowmeter, M1026-60144.
- Gas calibration equipment:
 - Cal 1 gas 15210-64010 (5% CO₂)
 - Cal 2 gas 15210-64020 (10% CO₂)
 - Cal gas flow regulator M2267A
 - Cal tube 13907A

In addition you will need a local barometric pressure rating received from a reliable local source (airport, regional weather station or hospital weather station) which is located at the same altitude as the hospital.

The CO₂ calibration for the sidestream Extension consists of the following steps:

- Barometric Pressure Check and Calibration, if required.
- Leakage Check
- Pump Check
- Flow Check and Calibration, if required.
- Noise Check
- CO₂ Cal Check and Calibration, if required.
- CO₂ Cal Verification using 2nd cal gas

NOTE

All steps should be performed in the same session.

Barometric Pressure Check and Calibration

Check the barometric pressure value in the sidestream CO₂ Extension as follows:

Step 1 Go into Service Mode and select CO₂.

Step 2 Connect a FilterLine to the sidestream CO₂ input. This activates the pump in the sidestream CO₂ Extension.

Step 3 Check the status line at the bottom of the screen. It will display "CO₂ pressure reading (ambient/cell) xxx/yyy" where xxx is the ambient pressure and yyy is the measured cell pressure. (The values are displayed with a resolution of 2 mmHg up to 475 mmHg and a resolution of 1 mmHg from 475 mmHg to 825 mmHg.) Check whether the ambient pressure value (x1) matches (within the acceptable tolerance of ±12mm Hg) the reference value you have received. If so, proceed to the Leakage Check. If the value is not correct, calibrate as follows.

- Step 4** Select CO₂ then select Barom.Press. A table of values is activated.
- Step 5** Select the value in the table which matches the reference value received from a reliable local source (airport, regional weather station or hospital weather station).
- Step 6** The selected value must be within $\pm 10\%$ of the current measured ambient pressure, otherwise an error message will occur at restarting the Monitor.
- Step 7** Confirm the barometric pressure setting.
- Step 8** Check that the ambient pressure displayed in the status line at the bottom of the screen is the same as the value which you selected from the list in step 5.

Leakage Check

The leakage check consists of two parts:

- Check of tubing between the pump outlet and the M3015A outlet.
- Check of tubing between the pump inlet and FilterLine inlet.

NOTE

Check the User's Guide of the flowmeter for details on how to make a correct flow reading.

Part 1

- Step 1** Go into Service Mode and highlight CO₂.
- Step 2** Connect a FilterLine to the sidestream CO₂ input to start the pump running.
- Step 3** Check the ambient and cell pressure shown in the status line on the screen. The cell pressure should be approximately 20 mmHg lower than ambient pressure.
- Step 4** Connect the flowmeter outlet to the FilterLine inlet using a flexible connecting tube.
- Step 5** Block the M3015A outlet using your fingertip and observe the flowmeter display. The value on the flowmeter (x2) should decrease to between 0 and 4 ml/min, accompanied by an audible increase in pump noise. If the value is within the tolerance limits, continue with Part 2 of the leakage check.
- Step 6** If the value is outside the tolerance limits, there is a leakage between the pump outlet and the M3015A gas outlet.
- Step 7** Open the M3015A and check the tubing connections at the pump outlet and the M3015A gas outlet. If the connections are good, then there is a leakage in the tubing and the M3015A must be exchanged.

Part 2

- Step 8** Disconnect the flowmeter from the Part 1 setup and connect the flowmeter inlet to the M3015A gas outlet.
- Step 9** Leave the Filterline connected to the M3015A inlet.

Step 10 Block the inlet of the FilterLine using your fingertip and observe the flowmeter display. The value on the flowmeter (x3) should decrease to between 0 and 4 ml/min, accompanied by an audible increase in pump noise. (Do not block the inlet for longer than 25 seconds as this will lead to an “Occlusion” INOP.) If the value is within the tolerance limits, there are no leakages and the leakage check is completed; proceed to the Pump Check.

Step 11 If the value is not within the tolerance limits, there is a leakage between the FilterLine inlet and the pump inlet.

Step 12 Check the FilterLine connections and open the M3015A to check the tubing connections at the pump inlet and the M3015A gas inlet. If the connections are good, try replacing the FilterLine and repeating the leakage check. If the situation remains, there is a leakage in the tubing and the M3015A must be exchanged.

Pump Check

Step 1 Connect the flowmeter inlet to the M3015A gas outlet.

Step 2 Connect the FilterLine to the M3015A inlet.

Step 3 Block the inlet of the FilterLine using your fingertip and observe the cell pressure on the M3046A display. The cell pressure (x4) should be more than 120 mmHg below the ambient pressure shown. If the pressure difference is less than 120 mmHg, the pump is not strong enough and should be replaced (irrespective of the Pump OpTime).

Flow Rate Check and Calibration

Check the flow rate in the sidestream CO₂ Extension as follows:

Step 1 Connect the flowmeter to the CO₂ FilterLine.

Step 2 Check on the flowmeter the flow that the sidestream CO₂ Extension Pump draws (x5). It should be 50 ml/min \pm 7.5 ml/min. If the value is within tolerance, proceed to the CO₂ Gas calibration check. If the value is not within tolerance, calibrate as follows.

Step 3 Adjust the flow in the Instrument by selecting “Increase Flow” or “Decrease Flow” until it is as close as possible to 50 ml per minute as indicated on the flowmeter gauge.

Step 4 When you are satisfied that the flow is set as close as possible to 50 ml per minute, select “Store Flow” and confirm the setting.

NOTE

If the adjusted flow is not stored within 60 seconds of the adjustment, the old flow setting will be restored

If the flow cannot be adjusted to within tolerance, the pump should be replaced. If the flow adjustment still cannot be made, this indicates a fault in the M3015A Measurement Extension, which must be replaced.

Noise Check

- Step 1** Check that the Monitor is in Service Mode and in the CO₂ window.
- Step 2** Disconnect the flowmeter and connect the 5% calibration gas and flow regulator in its place.
- Step 3** Open the valve to apply the 5% Calibration Gas and wait until the value is stable.
- Step 4** Check the Noise Index (x6) displayed next to the CO₂ value on the M3046A display (this indicates the level of noise on the CO₂ wave). If the value exceeds 3 mmHg the M3015A unit must be replaced.

CO₂ Gas Measurement Calibration Check

After switching the Measurement Extension on, wait at least 20 minutes before checking the calibration.

Check the calibration of the CO₂ Gas Measurement as follows:

- Step 1** Check that the 5% calibration gas and flow regulator are connected.
- Step 2** Calculate the expected measurement value in mmHg as follows:
$$0.05 \times (\text{ambient pressure}) = \text{value mmHg}$$

e.g. $0.05 \times 736 = 36.8$ mmHg (with an ambient pressure of 736 mmHg)
- Step 3** Open the valve on the flow regulator to allow 5% CO₂ gas to flow into the Extension. Allow the value to stabilize.
- Step 4** Check that the value on the instrument (measurement value on the Main Screen, x7)) matches the calculated mmHg value ± 2.6 mmHg. If the value is outside the tolerance, calibrate as described in Step 9 onwards.
- Step 5** Disconnect the 5% calibration gas and connect the 10% calibration gas.
- Step 6** Calculate the expected measurement value and tolerance in mmHg as follows:
$$0.1 \times (\text{ambient pressure}) = \text{value mmHg}$$
$$\pm 0.07 \times (\text{value mmHg}) = \text{tolerance}$$

e.g. $0.1 \times 737 \text{ mmHg} = 73.7 \text{ mmHg}$ (with an ambient pressure of 737 mmHg)
 $\pm 0.07 \times 73.7 \text{ mmHg} = \pm 5.16 \text{ mmHg}$ tolerance
- Step 7** Open the valve on the flow regulator to allow 10% CO₂ gas to flow into the Extension. Allow the value to stabilize.
- Step 8** Check that the value on the instrument (x8) matches the calculated mmHg value within the calculated tolerance. If so, the Measurement Extension is correctly calibrated. If the value is outside the tolerance, calibrate as follows
- Step 9** If not already connected, connect the 5% calibration gas.
- Step 10** Select Cal. CO₂.

- Step 11** Select the value for the calibration gas. (The default value is 5.0%.)
- Step 12** Open the valve on the calibration gas to allow CO₂ gas to flow into the Extension. Allow the value to stabilize before the start of the calibration. Leave the valve open until the instrument gives a prompt that gas can be removed.
- Step 13** The Extension calibrates and prompts when calibration is successful.

Calibration Verification

- Step 1** Reopen the 5% gas valve and allow the value to stabilize.
- Step 2** Check that the value displayed on the Monitor is correct within the tolerance (see Step 2 above).
- Step 3** Disconnect the 5% calibration gas and connect the 10% calibration gas.
- Step 4** Open the valve on the flow regulator to allow 10% CO₂ gas to flow into the Extension. Allow the value to stabilize.
- Step 5** Check that the value displayed on the Monitor is correct within the tolerance (see Step 6 above).

If one or both values are not within tolerances, the M3015A must be exchanged.

Checking and Resetting Time Counters

The time counters on the sidestream CO₂ Extension must be checked before calibrating the Instrument. As well, when parts are replaced, the appropriate counters must be reset to zero (*applies to units with serial number prefix DE020xxxx only*).

To check the counters, do the following:

- Step 1** Select the counter you want to check (either **Reset IRSourceTime** or **Reset PumpOpTime**).
- Step 2** Press and hold lightly on the TouchStrip. The counter time will display.
- Step 3** Release to view or press harder to reset. In addition, always observe the following guidelines:
- When calibrating the CO₂ Extension, if no parts have been replaced, check the values displayed on the **Reset PumpOpTime** and **Reset IRSourceTime** selections to make sure that they are within suggested guidelines for use (15,000 hours of use). If the counter time is greater than 15,000 hours, replace the appropriate part. See "Repairing the Instrument".
 - When calibrating the CO₂ Extension, if parts have been replaced, reset the appropriate values displayed on the **Reset PumpOpTime** and **Reset IRSourceTime** selections to zero. See "Repairing the Instrument".

NOTE When the PumpOpTime has been reset an INOP will be generated: “CO₂ OCCLUSION”. To clear this INOP, you must perform a flow check and store the flow in Service Mode (select “Store Flow”).

Documenting CO₂ Test Results

Test	Expected Test Results	What to record on service record
Barometric Pressure Check	X1 = difference between the reference pressure and the measured ambient pressure displayed on the M3046A (X1 < 12 mmHg)	PCO ₂ :P/x1/x2/x3/x4/x5/x6/x7/x8 or PCO ₂ :F/x1/x2/x3/x4/x5/x6/x7/x8 P = passed, F = failed X1: xx (two digits) X2: x.x X3: x.x X4: xxx X5: x.x X6: x.x X7: x.x X8: x.x
Leakage Check parts 1 and 2	X2 = Value of part 1 leakage check on Flowmeter (X2 < 4.0 ml/min) X3 = Value of part 2 leakage check on Flowmeter (X3 < 4.0 ml/min)	
Pump Check	X4 = difference in pressure between cell pressure and ambient pressure displayed on the M3046A during occlusion (X4 > 120 mmHg)	
Flow Check	X5 = difference between measured value and 50.0 ml/min (X5 < 7.5 ml/min)	
Noise Check	X6 = Noise Index displayed on M3046A (X6 < 3.0)	
CO ₂ Gas Calibration Check	X7 = difference between measured CO ₂ value and calculated value, based on 5% CO ₂ cal. gas. (X7 < 2.6 mmHg)	
CO ₂ Cal Verification	X8 = difference between measured CO ₂ value and calculated value, based on 10% CO ₂ cal. gas. (X8 < ± {0.07 x value calculated})	

Accuracy and Performance Procedures

The following accuracy, calibration, and performance procedures are designed to be completed to verify the accuracy and performance of the Instrument. They must be performed once every two years and when the Instrument is repaired or when Instrument parts are replaced.

Temperature Accuracy

This test checks the performance of the temperature parameter. The temperature accuracy test is required once every two years.

Tools required: Patient simulator (with 0.1°C or 0.2°F)

Step 1 Connect the patient simulator to the temperature connector on the Measurement Server or Measurement Server Extension.

Step 2 Configure the patient simulator to 40 °C or alternatively 100 °F

Step 3 The value should be 40 °C ± 0.2 °C or 100 °F ± 0.4 °F.

If the displayed value is not within the tolerances given above, refer to "Troubleshooting the Instrument".

ECG/Resp Performance

This test checks the performance of the ECG and respiration parameters. ECG/Resp performance test is required once every two years.

Tools required: Patient Simulator.

ECG Performance

Step 1 Connect the Patient Simulator to the ECG/Resp connector on the Measurement Server.

Step 2 Configure the Patient Simulator as follows:

- ECG sinus rhythm.
- HR = 100 bpm

Step 3 Check the displayed ECG wave and HR value against the simulator configuration.

Step 4 The value should be 100bpm +/- 2bpm.

Respiration Performance

Step 5 Change the Patient Simulator configuration to:

- Base impedance line 1500 Ohm.
- Delta impedance 0.5 Ohm
- Respiration rate 40 rpm.

Step 6 The value should be 40 rpm +/- 2 rpm.

Invasive Pressure Performance Test

This test checks the performance of the invasive pressure parameter. The Invasive Pressure performance test is required once every two years.

Tools required: Patient Simulator.

Step 1 Connect the Patient Simulator to the Pressure connector on the Measurement Server or the Measurement Server Extension.

Step 2 Set Patient Simulator to 0 pressure.

Step 3 Make a zero calibration.

Step 4 Configure the Patient Simulator as follows:

- $P(\text{static}) = 200 \text{ mmHg}$.

Step 5 Wait for the display.

Step 6 The value should be $200 \text{ mmHg} \pm 5 \text{ mmHg}$. If the value is outside these tolerances, calibrate the Measurement Server or Measurement Server Extension.

If the Measurement Server was calibrated with a dedicated reusable catheter, check the calibration together with this catheter.

NOTE

SpO₂ Performance Test

This test checks the performance of the SpO₂ parameter. The SpO₂ performance test is required once every two years.

Tools required: none

Step 1 Connect an adult SpO₂ transducer to the SpO₂ connector on the Measurement Server.

Step 2 Measure the SpO₂ value on your finger (this assumes that you are healthy).

Step 3 The value should be between 95% and 100%

Mainstream CO₂ Performance Test

This test checks the performance of the mainstream CO₂ parameter. The mainstream CO₂ performance test is required once per day and when the Instrument is repaired or when Instrument parts are replaced.

This mainstream CO₂ performance test is a User task and is described in the *Instructions for Use*. There is no requirement for additional tests to be performed by the Service Engineer or Biomedical Engineer.

Nurse Call Relay Performance Test

This test checks the operation of the Nurse Call Relay. The Nurse Call Relay test is recommended for customer sites where the nurse call is in use. It should be performed once every two years and when the Instrument is repaired or when Instrument parts are replaced.

The Nurse Call relay functions as follows:

- Standard Operation—Relay open.
- Alarm Condition—Relay closed.

Tools required: Ohmmeter.

Step 1 Plug a phono connector into the Nurse Call Relay connector.

Step 2 Connect the ohmmeter.

Step 3 If no alarm occurs, the relay contacts are open.

NOTE

When an alarm occurs, the relay contacts close.

NOTE

The conditions described above are the unmodified conditions. Please check accordingly if the Nurse Call Alarm relays have been modified (see “Modification for Nurse Call Alarm Relays” on page 76).

ECG Sync Performance Test

This test checks the performance of ECG synchronization between the Monitor and a defibrillator. The ECG sync performance test is required once every two years and when the Instrument is repaired or when Instrument parts are replaced.

Tools required:

- Defibrillator with ECG Sync and Marker Output.
- Patient simulator.

Step 1 Connect the patient simulator to the ECG connector on the Measurement server and the defibrillator to the ECG Sync Output on the M3046A.

Step 2 Set the Patient simulator to the following configuration:

- HR = 100 bpm.
- ECG sinus rhythm.

Step 3 Switch the defibrillator to simulation mode.

Step 4 Check that the marker pulse is displayed before the T-wave begins.

Patient Safety Checks

Warnings, Cautions, and Safety Precautions

- The tests described in the following paragraphs are recommended to be performed every two years **and** following any installation, major repair or upgrade procedure as a proven means of detecting abnormalities that if undetected could prove dangerous to either the patient or the operator.
- All tests can be performed using commercially available *Safety Analyzer* test equipment. Basic measurements may also be performed with widely available multifunction instruments like the HP 3469A multimeter or equivalent.
- The consistent use of a *Safety Analyzer* as a routine step in closing a repair or upgrade is emphasized as a mandatory step if approval agency status is to be maintained. The *Safety Analyzer* also proves to be an excellent troubleshooting tool to detect abnormalities of line voltage and grounding plus total current loads.
- For Europe and Asia/Pacific according to:
IEC60601-1:1988 + A1:1991 + A2:1995 = EN60601-1:1990 +A1:1991 + A2:1995
For USA according to:
UL2601-1
- Additional tests may be required according to local regulations.
- Normally, a *Safety Analyzer* is used to perform these procedures. Popular testers include the DEMPSEY 232D, or for use in Europe, testers like the Rigel, Metron or Gerb. Follow the instructions of the Instrument manufacturer.

CAUTION

If the Dempsey is used for an extended length of time, it could be damaged by the high amp current draw of the system

NOTE

It is recommended that you file the results of annual tests. This may help to identify a problem early particularly if the test results deteriorate over a period of time.

Safety Test Procedures

The test procedures outlined in this appendix are to be used **only** for verifying safe installation or service of the product in question. The setups used for these tests and the acceptable ranges of values are derived from local and international standards but may not be equivalent. These tests are **not a substitute for local safety testing** where it is required for an installation or a service event. If using the Metron Safety tester use your local regulation to perform the test, *for example* in Europe IEC601-1/IEC601-1-1 and in the US UL2601-1. The Metron Report should print results with the names listed below, along with other data.

S(1) Part 1: System Enclosure Leakage Current - NC (normal condition)

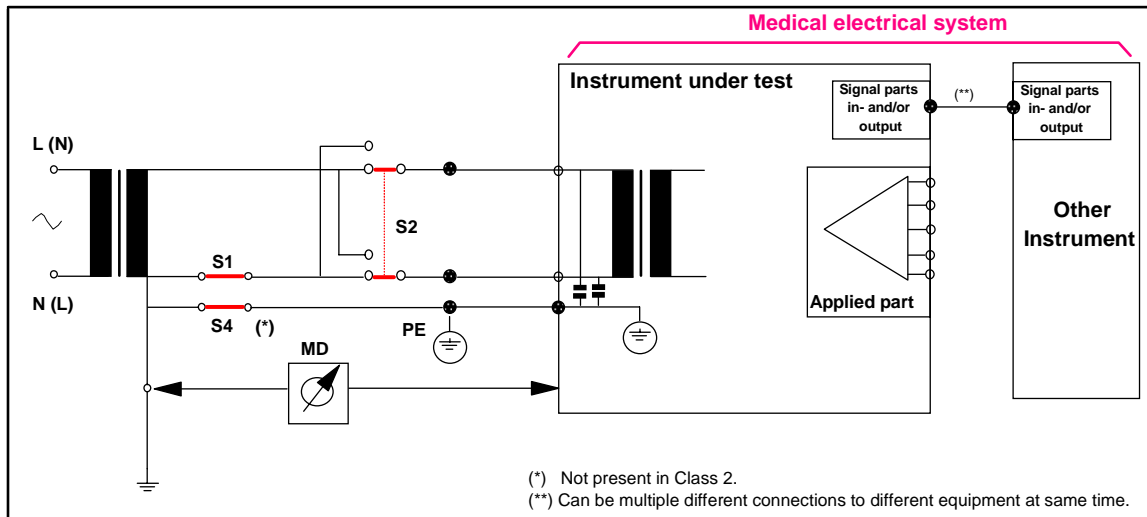

Expected test results:

Normal condition maximum leakage current $x1 \leq 100\mu\text{A}$

Measures leakage current of exposed metal parts of Instrument under Test (IUT) and between parts of the system within the **patient environment**; normal and reversed polarity using S2.

Safety test according IEC 60601-1 / UL2601-1

S(1) Part 2: System Enclosure Leakage current - Single Fault (open earth)

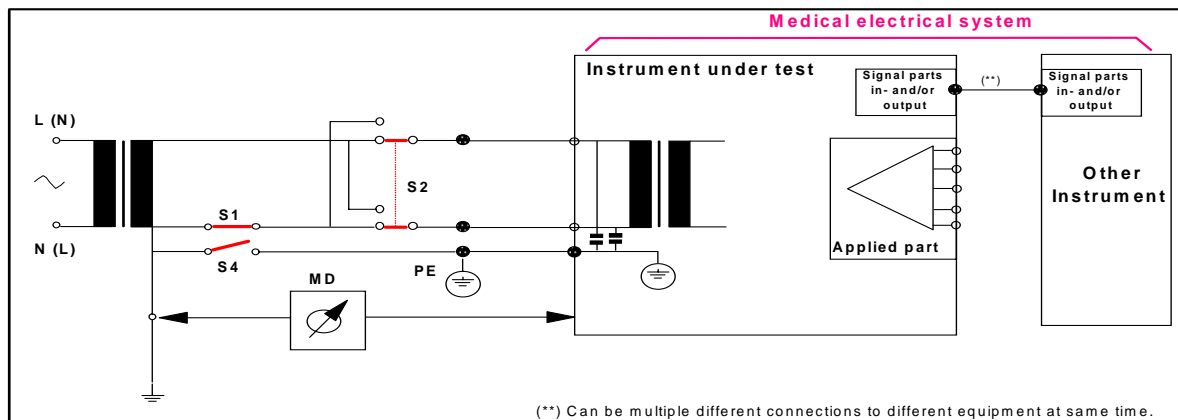

Expected test results:

$$\begin{aligned} \text{Single Fault maximum leakage current } x2 &\leq 500\mu\text{A (IEC 60601-1)} \\ &\leq 300\mu\text{A (UL2601-1)} \end{aligned}$$

Measures leakage current of exposed metal parts of Instrument under Test (IUT) with Protective Earth (PE) open circuit (S4 = open) and between parts of the system within the **patient environment**; normal and reversed polarity using S2.

Reporting safety test S(1) in the Service record

S(1):P/x1/x2

or

S(1):F/x1/x2

where P = Pass, F = Fail and x1, x2 are the values defined in the two tests described above.

S(2) Protective Earth Continuity

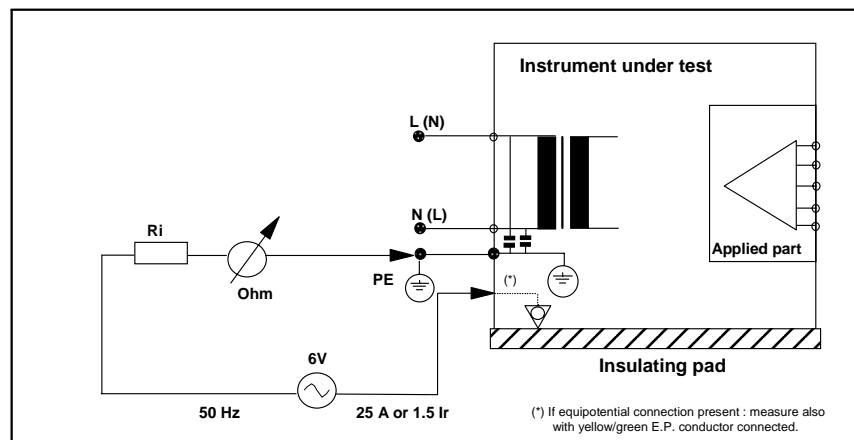

Expected test results:

With mains cable, maximum impedance $x = 100 \text{ mOhms}$ (IEC 60601-1 and UL2601-1)

Measures impedance of Protective Earth (PE) terminal to all exposed metal parts of Instrument under Test (IUT), which are for safety reasons connected to the Protective Earth (PE). Test current 5 Amp applied for 5 to 10 seconds.

Reporting safety test S(2) in the Service record

S(2):P/x

or

S(2):F/x

where P = Pass, F = Fail and x is the value defined in the test described above

S(3) Patient Leakage current - Single Fault Condition (S.F.C.) mains on applied part

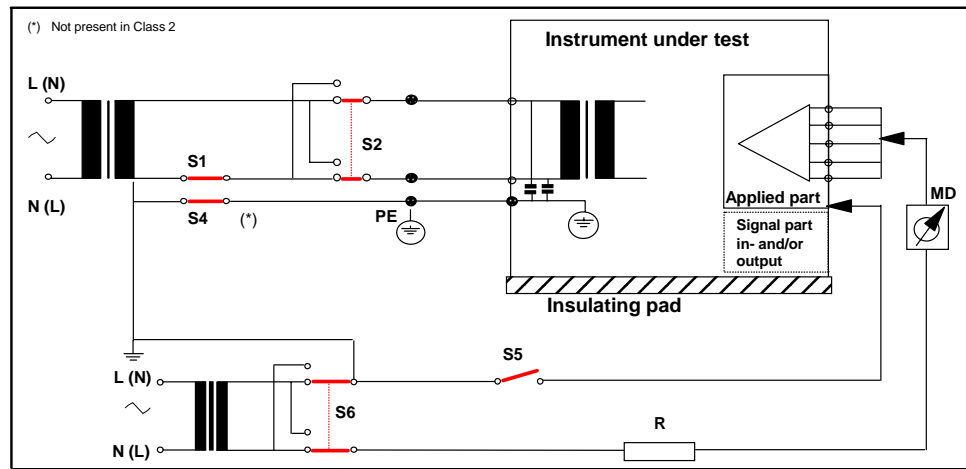

Expected test results:

Maximum leakage current, $x = 50\mu\text{A}$ @ 250V (IEC60601-1 and UL2601-1)

Measures patient leakage current from applied Part to earth caused by external main voltage on applied Part with switch S5 open and closed. Each polarity combination possible is tested using S2 and S6. This test is applicable for every measurement input (ECG / RESP, Invasive Pressure, CO₂, SpO₂, Temperature)

Reporting safety test S(3) in the Service record

S(3):P/x

or

S(3):F/x

where P = Pass, F = Fail and x is the value defined in the test described above

Tutorial for Testing the Instrument

Question 1: According to this chapter, which of these statements correctly identifies the distinction between Preventive Maintenance and Performance Testing?

- a. Performance testing includes safety testing and checks. It refers to all accuracy and performance tests to be made on the Instrument other than NBP calibration and sidestream CO₂ calibration.
- b. When authorized Philips personnel service the Instrument, they report the results of Preventive Maintenance testing back to Philips. The collected data forms a database to be used in product development. It is not necessary for hospital personnel to report results.
- c. Preventive Maintenance can be defined as service calibration testing required to make sure the Instrument measurement results are accurate. These specific tests are required for the NBP parameter and for the sidestream CO₂ parameter.
- d. All of the above answers are correct.

Question 2: In the case of all testing procedures done either by hospital staff or by authorized Philips personnel, what should be done with the results?

- a. File them for reference to help identify problems early if test results deteriorate over time.
- b. Discard them.
- c. File them but do not consult them in case of problems.

Question 3: Which is the one parameter that requires daily calibration testing?

- a. SpO₂ performance.
- b. Temperature performance.
- c. Mainstream CO₂ performance.

Answers to the Tutorial for Testing the Instrument

- 1) d. (See page 137 for more details.)
- 2) a. (See entire chapter for more details.)
- 3) c. (See page 157 for more details.)

5 Troubleshooting the Instrument

Objectives

In order to meet this chapter's objectives, you should be able to diagnose and isolate hardware failures to the level of the "field replaceable part".

In addition, this chapter describes how to troubleshoot problems using error codes and other support functions including:

- How to use the Status Log to check for error codes, and other service information.
- How to interpret error codes and how to use them to isolate faults.

Use this chapter when you suspect you have a problem with your Monitor, your Measurement Server or your Measurement Server Extension, or whenever you are referred to this chapter from another part of the Service Guide.

This chapter is divided as follows:

Part 1 Troubleshooting Checklists—This part provides *check for the obvious* hints and tips.

Part 2 Isolating and Solving Instrument Problems—This part provides the following:

- Tables that list Instrument symptoms as well as causes and remedies for Instrument faults.
- Techniques for troubleshooting the Instrument before you disassemble it.
- Checks you can make to isolate problems down to a specific replaceable part, for example, the Power Supply.

You can often determine whether a failure has occurred simply by referring to the troubleshooting table in "Part 2 Isolating and Solving Instrument Problems".

Part 3 Using Support Functions—This part describes support features available to the Measurement Server and the Measurement Server Extension as follows:

- Information on how to use error codes.
- A description of the boot process.

Concepts

Trouble shooting This is the essential diagnostic step to be taken prior to any repair.

INOPs and Error Codes These are the types of messages that generate and display to inform the user when the Instrument has been unable to perform an operation.

Part 1 Troubleshooting Checklists

Checks for Obvious Problems

When first troubleshooting the Instrument, check for obvious problems by answering basic questions such as the following:

- 1 Is the power switch turned on?
- 2 Is the battery adequately charged?
- 3 If running from mains power supply, is the AC power cord connected to the Instrument and plugged into an AC outlet?
- 4 Are the Measurement Server and, if present, the Measurement Server Extension inserted correctly?

Checks Before Opening the Instrument

You can isolate many problems by observing indicators on the Instrument before it is necessary to open the Instrument.

Checks with the Instrument switched Off

- AC connected, without battery:
 - AC Power LED is on (green).
- AC connected, with battery:
 - AC Power LED is on (green).
 - Battery LED is on (green if fully loaded, yellow if being charged).
 - Battery LED red and blinking signals battery malfunction.
- No AC connected, with battery:
 - All LEDs are off.

NOTE

It takes several seconds for the AC Power LED to switch on / off after the mains power cord has been connected / disconnected.

Checks with the Instrument Switched On, AC connected, without Battery

- AC Power LED is on (green).
- After pressing the On-Off/Standby switch, the following sequence occurs:
 - The On/Off LED switches on immediately.
 - The Alarm LED and the Suspend LED both switch on (red) and the Battery LED switches on (yellow).
 - After 1 second, the Alarm LED switches to yellow then, after 1 second more, all three LEDs (Alarm, Suspend & Battery) switch off.
 - As the LEDs switch off, the speaker test occurs with an audible tone.
 - Shortly after the LEDs switch off, the display backlight switches on and the M3 logo displays.

Checks with the Instrument Switched On, AC connected, with Battery

The LEDs behave the same as described in the Checks with the Instrument Switched on, AC Connected, without Battery (above) *except* that the Battery LED does the following:

- The Battery LED is initially on then switches first to yellow and then off for several seconds.
- Finally, the Battery LED switches to its current status-color.

Checks with the Instrument Switched On, AC not Connected, with Battery

The LEDs behave the same as described in Checks with the Instrument Switched on, AC Connected, without Battery (above) *except* that the AC Power LED is permanently off.

Troubleshooting the Front-Panel LEDs

When the Monitor is first switched on, all the front-panel LEDs and keys light up momentarily. The meaning of the front-panel LEDs under normal operation is given in the following table together with a brief summary of possible defect conditions:

LED	Normal Operation	Defect Condition
On Off/Standby	Green: The Monitor is on. Off: The Monitor is in standby mode.	The LED remains off: Suspect: 1. Monitor Bezel cable connection. 2. System Board Go to the troubleshooting section.
AC Power	Green: The Monitor is connected to the mains power supply.	The LED remains off: Suspect: 1. Power Supply. 2. Monitor Bezel cable connection. 3. System Board. Go to the troubleshooting section.
Battery	Green: The battery is fully charged (>95%). Yellow: The battery is charging. Red and blinking: The battery is empty.	Same as for AC Power condition.

- With the Instrument on, observe the following:
- The backlight tube lights the LCD display.
- No error messages are displayed. Error messages indicate either software or hardware fault has occurred. If error messages are displayed, refer to error codes later in this chapter.
- The brightness of the LCD display is adequate. If not, adjust it accordingly.
- The green LED on the System Board is on (see the following section).

Troubleshooting the System Board LEDs

Switch the Monitor off then on again to observe the System Board LEDs. These can be viewed through the top left corner of the rear panel. (You need to remove the Server to view these LEDs).

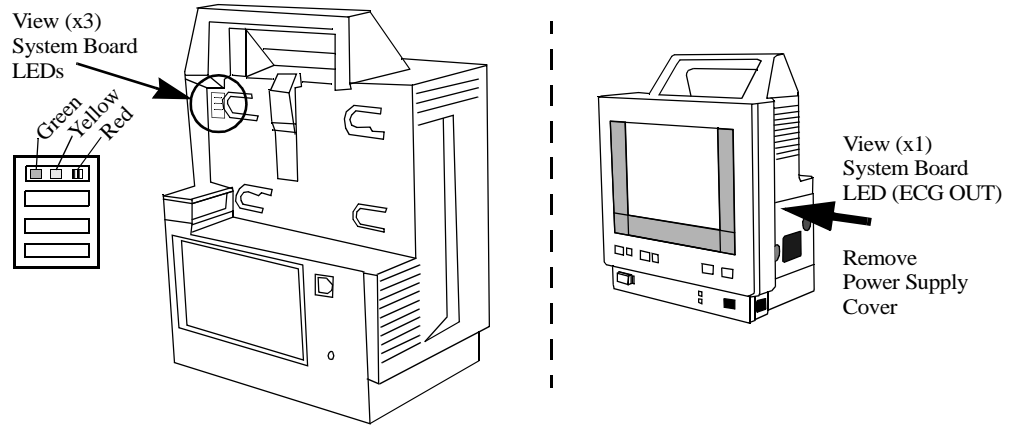

The meaning of the System Board LEDs is given in the following table together with a brief summary of possible defect conditions:

LED	Description	Defect Condition
Green	+5V power LED. When on, indicates the presence of +5V.	Off: Check Power Supply and associated cabling.
Yellow	Main CPU status LED—When on and blinking, this LED indicates normal CPU operation. This LED starts to blink 2 times per second after the red Error LED switches off then slows to blink 1 time per second after the red Error LED switches off when the system boot has finished (approximately 2 seconds).	If permanently on or off, indicates a hung CPU. - Reload software - Exchange system board.
Red	Error LED—When on, this LED indicates an error. This LED switches on for about 1 second after the System Board has been reset then switches off.	If permanently on, the System Board is probably defective.

An ECG OUT LED is also located on the System Board and can be viewed after removing the Power Supply cover. The meaning of the ECG OUT LED is as follows:

- When permanently on (>20 seconds), this LED indicates an error in the ECG_OUT section.
- If a single fatal error in the ECG_OUT section is detected during power-on, the ECG OUT LED switches on for up to 20 seconds.
The ECG OUT LED switches off if this fatal error cannot be detected again after 20 seconds.
- At power-on, the ECG OUT LED switches on for about 1 second then switches off.
- Every time the ECG_OUT communicates with the Server, the ECG OUT LED blinks twice.
- Every time an error in the ECG_OUT communication to the Server is detected, the ECG OUT LED switches on for 1-2 seconds.

Troubleshooting the Display Adapter Board LED

WARNING

High Voltage - Voltages dangerous to life are present in the Instrument when it is connected to the mains power supply. Do not attempt any adjustment, or make any contact with the monitor while AC power is connected.

The green LED on the Display Adapter Board can be seen if the chassis is removed from the plastic housing. It is located on the left side (speaker side) looking through the lower hole of the metal display holder and can be seen below the brown flex cable which connects the Display Adapter Board and the TFT panel. Its conditions are as follows:

- The Display Adapter Board LED switches on for approximately 3 seconds following a reset of the System Board.
- If the Display Adapter Board LED does not switch on after a reset, this is an indication that the flat ribbon cable to the Display Assembly is not seated correctly.

Troubleshooting the Wireless Assembly LEDs

The Wireless Assembly LEDs can be seen when the gray cover on the right side of the monitor, above the link bar, is open.

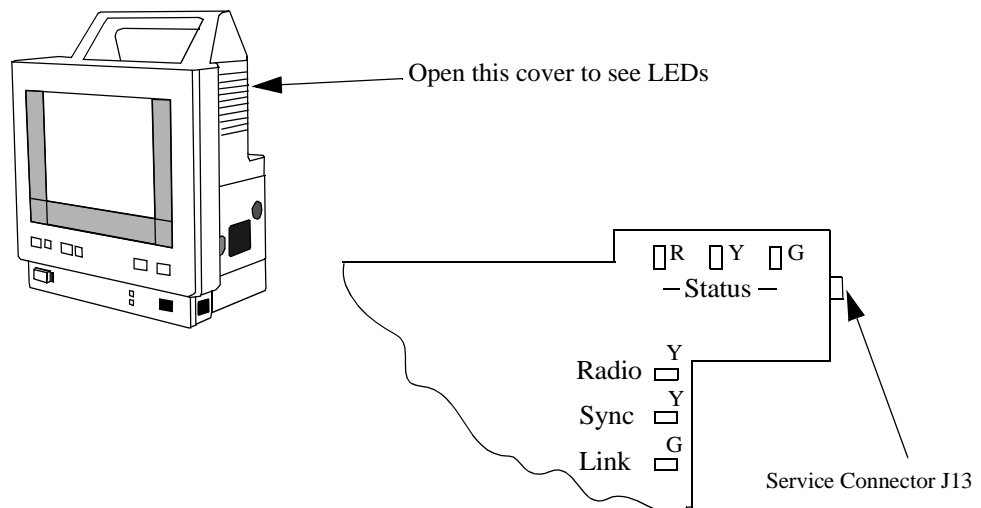

Status LEDs**NOTE**

If all three status LEDs, the Radio LED and the Internal Link LED are on continuously and the Sync LED is off, then this indicates that the Monitor has turned off the radio and is communicating over the hardwired LAN connection (a cable is plugged into the LAN (RJ-45) connector on the rear of the Monitor).

There are three status LEDs, one red, one yellow and one green. At power up, all three LEDs flash on and off a few times, then the red and green LEDs will turn off and the yellow LED will turn on during self test. If everything is operating properly, the yellow LED will go off and only the green LED will be on.

If the red status LED turns on during self test, there is a hardware problem with the wireless assembly (includes a CPU board and a radio card). If a hardware failure is found during operation the red LED will blink repeatedly.

The Status LEDs are yellow directly after Power On, during initialization. During normal operation they are green. If a problem occurs during operation the LEDs blink red in a repeating pattern.

Radio LED

The radio LED blinks yellow when the wireless assembly is transmitting data packets over its radio.

Sync LED

This LED should be on solidly during normal operation. It indicates that the M3 is synchronized with an Access Point.

NOTE

This LED may blink occasionally even when the unit is synchronized to a master.

Internal Link LED

This LED indicates that there is an internal connection to the M3 System Board. This LED blinks when the wireless assembly sends packets through the internal connection to the system board.

NOTE

This LED may blink on occasion even if the link between the Ethernet Adapter and the System Board is defective.

Troubleshooting the Measurement Server LEDs

The Measurement Server LEDs can be seen from the rear view of the Instrument.

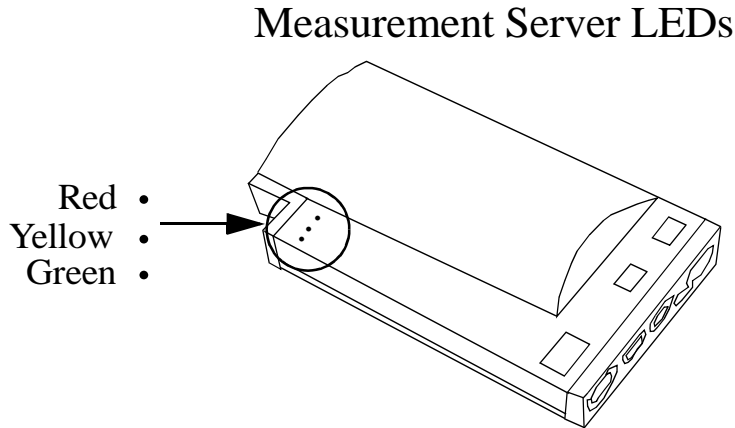

The functions of the three LEDs in the Server are identical to the three LEDs on the Instrument System Board:

LED	Description	Defect Condition
Green	+5V power LED—When on, this LED indicates the presence of +5V.	Off: Check Power Supply and associated cabling. Go to the troubleshooting section.
Yellow	Main CPU status LED—When on and blinking, this LED indicates normal CPU operation. Starts to blink 2 times per second after the red Error LED switches off then slows down to blink 1 time per second after the red Error LED switches off when the system boot has finished (approximately 2 seconds).	If permanently on or off, indicates a hung CPU. - Reload software - Exchange system board.
Red	Error LED—When on, this LED indicates an error. This LED switches on for about 1 second after a System Board reset then switches off.	If permanently on, the Server is probably defective.

First Steps

The first two steps are to make sure that the paths AC power supply and battery to +5V System Board supply voltages work correctly.

What To Do if the Monitor Cannot Be Switched On, AC powered

- Remove the battery.
- Connect AC power. The AC Power LED should switch on within several seconds.
- Switch the Instrument on. The On-Off/Standby LED should switch on.
- If either the AC Power LED or the On-Off/Standby LED remain off, check if the Monitor Bezel and display cables are connected properly to the System Board.
- Check the display cable is seated correctly (particularly if it is offset by one row too low—in this case the +5V is shorted to ground and the Instrument remains off).
- If the AC power LED still remains off, check the AC power supply. (If necessary, replace the fuses on the Power Supply board or replace the complete Power Supply).
- If the AC power LED still remains off and/or the Monitor still cannot be switched on, the Monitor Bezel might be defective. Try a *known-good* Monitor Bezel.
- If the AC Power LED still remains off and/or the Monitor still cannot be switched on, replace the System Board.

What To Do if the Monitor Cannot Be Switched On, Battery powered

- Connect AC power to the Monitor and make sure it can be switched on and operates properly.
- Make sure that the battery is adequately charged (press charge indicator on battery, at least one green LED should switch on).
- Insert the battery into the Monitor (AC power still connected), the Battery LED should switch on (green, yellow, or red).
- If the Battery LED remains off or is red, replace the battery with a *known-good* one.
- If the Battery LED still remains off, either the LED is defective or the battery control circuit on the System Board is defective.
- To check whether the Battery LED is defective, disconnect AC power and switch on the Monitor. If the Monitor works, most likely the Battery LED is defective. In this case, replace the Monitor Bezel.
- To check whether the System Board is defective, disconnect AC power and switch on the Monitor. If the Monitor remains off, either the battery fuse (surface mounted) on the Connector Board is blown or the System Board is defective. If necessary, replace the Connector Board.
- If the Monitor still remains off, the battery control circuit on the System Board is defective. (Replace the System Board).

Initial Instrument Boot Phase

The following steps are to ensure that the Monitor finishes its first boot phase and the application software starts running. The application software is running when the yellow LED blinks slowly (1 time per second).

For these steps it is assumed that the Monitor is powered correctly and the +5V System Board supply voltage is okay. This is indicated by the On-Off/Standby LED and the green LED on the Main Board (upper left) both on.

What Happens During a Regular Boot, AC powered, without Battery

The Monitor Bezel LEDs, tone and display come up as follows:

- The AC Power LED is on.
- When the On-Off/Standby switch is pressed, the On-Off/Standby LED switches on immediately.
- The Alarm LED and the Suspend LED both switch on red and the Battery LED switches on yellow. After 1 second, the Alarm LED switches to yellow, after 1 second all three switch off.
- At the same time as the LEDs switch off, the speaker is tested with an audible tone.
- Shortly after the LEDs switch off, the display backlight switches on and the M3/M4 logo displays.

The Three LEDs on the System Board come up as follows:

- Green LED—When the On-Off/Standby switches pressed, the green LED switches on immediately.
- Yellow LED—The yellow LED blinks 2 times per second after the red Error LED switches off then slows down to blink 1 time per second when the first system boot phase finishes (after approximately 2 seconds).
- Red LED—The red LED switches on for about 1 second after a power on (RESET) of the System Board then switches off.

If the boot process is not successful for any reason, check for obvious problems (Part 1 Troubleshooting Checklists).

What To do If the Display Remains Dark

If the three LEDs on the System Board indicate that the first boot phase has finished (green=on, red=off, yellow=blinking once per second) but the display remains dark, check the following:

- Check that the display cable is seated correctly.
- Check (in the Display Assembly) that the video flex layer is snapped correctly onto the connectors on the Display Adapter Board and check the TFT panel by pressing onto the flex layer at the connectors.

NOTE

Do not try to remove the video flex layer because, if snapped on correctly, removing it can easily damage the SMT solder joints.

- Check that the cables of the backlight tubes are seated correctly into the backlight inverter.
- Check the backlight tubes are working correctly (broken, damaged, or worn).
- If the display still remains dark either the Display Assembly or the System Board is defective. It is recommended to replace the Display Assembly first.

What To Do if the Alarm and Suspend LEDs Are Not Working Correctly

If the Monitor boots until the display is switched on but the Alarm LED and the Suspend LED have not switched as described previously (red, red/yellow then off), suspect the following:

- Check that the Monitor Bezel cable is seated correctly.
- Replace the Monitor Bezel.
- Replace the System Board.

Isolating Problems to the Correct Subassembly

WARNING

High Voltage - Voltages dangerous to life are present in the Instrument when it is connected to the mains power supply. Do not perform any disassembly procedures (other than Server and Extension removal) with power applied to the Instrument. Failure to adhere to this warning could cause serious injury or death.

Troubleshooting the ECG OUT

If no marker pulse is displayed on the Monitor (assuming the defibrillator and defibrillator cable are in working order), check the following:

- Disconnect the Server and Defib cable.
- Switch the Monitor off then on again. Observe the red LED in the ECG OUT section. (The Instrument Self-Test is performed).
- If the red LED does not switch on for about 1 second at power on, replace the System Board.
- If the red LED switches on and remains on for more than 20 seconds, replace the System Board.
- Use a *known-good* link bar and connect a Defib, Defib cable and the Measurement Server again. Check marker pulse again.
- Use a *known-good* Measurement Server. Check marker pulse again.
- If both of the above fail, replace the System Board.

If there is no ECG OUT signal to the Defib, repeat the above checks.

Data Flow Marker In and ECG Wave

The following illustrates the data flow for Marker In and ECG Wave:
 Defib <—> Monitor <—> Measurement Server:

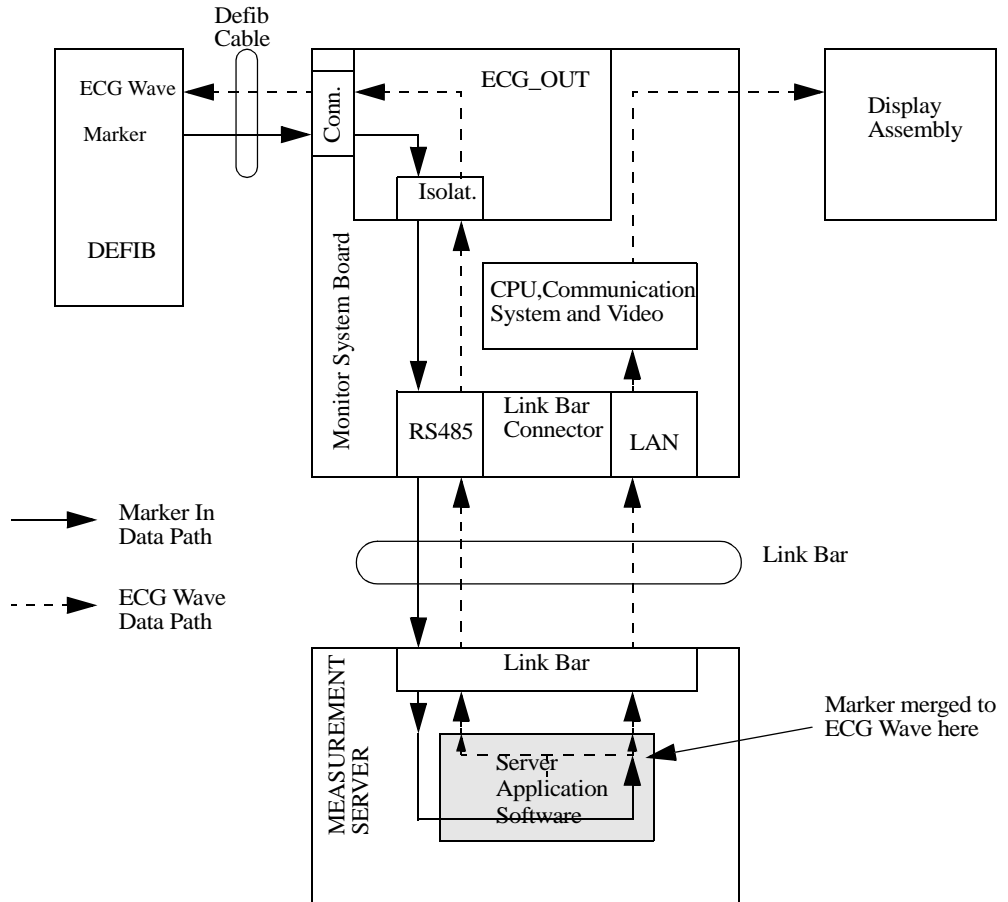

Part 2 Isolating and Solving Instrument Problems

INOP Messages

The following table explains the technical INOP messages that the Monitor can issue, and suggests a course of action. Where actions are numbered, always try them in the order given and only proceed to the next action if the current one is not successful in solving the problem.

Message	Cause of Failure	Remedy
BAD SERVER LINK	You cannot use this combination of Monitor, Measurement Server and cable. Switch off the monitor and contact your biomedical department.	Use standard equipment (link bar, cable, Server or Extension). (The link bar connects the Server and, where present, the Extension, to the Monitor.) Update Software
BAD SERVER LINK plus “Measurement Server Revision not supported” status message in red.	An M3000A Measurement Server with revision A software is connected to an M3046A Monitor with a software revision of B or later. This combination does not allow monitoring.	Update Software
BATTERY EMPTY	Battery is almost empty.	1. Change battery. 2. Connect to AC power supply.
BATTERY LOW	The battery has less than 20 minutes’ charge left.	Recharge the battery.

<p>BATTERY MAL-FUNCT.</p>	<p>The status of the battery cannot be determined. The presence of the battery is recognized but communication is not possible. This may happen if the battery has been totally (deep) discharged by leaving it in the Monitor too long.</p>	<ol style="list-style-type: none"> 1. Leave the battery in the Monitor for at least two hours, as communication may restart without further action. If the message is still displayed after this time, replace the battery. 2. Change the System Board 3. Change the Connector Board.
<p>CHARGER MAL-FUNCT.</p>	<p>Either the battery or the charging hardware within the Instrument is defective.</p>	<ol style="list-style-type: none"> 1. Change battery. 2. Change the System Board.
<p>CHECK INPUT DEVICE</p>	<p>The Monitor has detected 5 minutes or more of constant user interface operation, or the user interface is faulty.</p>	<ol style="list-style-type: none"> 1. Make sure nothing is pressing on the keys or the TouchStrip. 2. Check that the Monitor Bezel is mounted securely and for damage. 3. Check the Monitor Bezel assembly cables. 4. Replace the Monitor Bezel. 5. Replace the System Board.
<p>MEAS SERV UNPLUGGED</p>	<p>No Server is connected or communication is not possible.</p>	<ol style="list-style-type: none"> 1. Make sure the Server is connected to the Monitor or, if present, to the Extension. 2. Replace the Server with a <i>known-good</i> Server. 3. Check link bar and cables. 4. Replace the System Board.

MEASSERV UNSUPPORTD	An incompatible Measurement Server (including any M3000A) is connected to a Monitor with Rev. E software.	Use only M3001A Server with a Monitor with Rev. E software.
SERVERLINK MALF	Either the current is too high or the voltage is too low.	<ol style="list-style-type: none"> 1. Make sure the Server is connected to the Monitor. 2. Replace the Server with a <i>known-good</i> Server. 3. Check link bar and cables. 4. Replace the System Board.
SPEAKER MAL- FUNCTION	Defective speaker or cables.	<ol style="list-style-type: none"> 1. Check cable connections. 2. Replace speaker. 3. Replace the System Board.
UNSUPPORTED LAN	An unsupported device has been connected to LAN port of the Monitor.	Disconnect the unsupported device.
CO ₂ EQUIP MALF (M3015A and M3016A)	Malfunction in the CO ₂ hardware or the M1460A transducer hardware.	Verify failure and replace the Extension with a <i>known-good</i> Extension.
CO ₂ NO TRANS- DUCER (M3016A)	M1460A Transducer not connected. Silencing this INOP switches the parameter off. If the transducer is replaced, the new transducer must be calibrated.	<ol style="list-style-type: none"> 1. Connect a transducer. 2. Replace a defective transducer and recalibrate the parameter.

CO ₂ CAL FAILED (M3016A)	Calibration aborted due to power failure, unstable signal during calibration or transducer placed on the wrong calibration cell.	<ol style="list-style-type: none"> 1. Verify power source. 2. Perform calibration procedure again. 3. Replace transducer and repeat calibration again. 4. Replace the extension.
CO ₂ CHECK CAL (M3016A)	CO ₂ value is less than -4mmHg, greater than 150 mmHg.	Check that calibration values are within specified limits by performing an accuracy check. Calibrate, if required.
CO ₂ SENSOR WARM UP	The sensor has not reached operating temperature.	Allow the sensor to warm up.
CO ₂ WAIT CAL 2 (M3016A)	The CAL 1 calibration cycle is complete; the CAL 2 calibration cycle must be started.	Place sensor on other cal cell and start the CAL 2 calibration cycle.
CO ₂ CAL RUNNING (M3016A)	CO ₂ calibration is running.	Wait for CO ₂ calibration to complete.
CO ₂ CAL MODE (M3016A)	Cal mode is set but the calibration has not been initiated.	Initiate the calibration or switch off cal mode
CO ₂ CHANGE SCALE	ETCO ₂ wave is larger than the display channel.	Increase the scale of the display channel.
CO ₂ UPDATE FW (M3015A)	The software in the Measurement Extension does not match the software in the Measurement Server. This is only likely to occur after a repair or upgrade.	<p>Perform the Firmware update in CO₂ Service Mode:</p> <p>select “Update Firmware” and follow the instructions on the display.</p> <p>In certain situations, no update is possible - in these cases, continued operation is possible despite the INOP.</p>

CO ₂ NO TUBING (M3015A)	The FilterLine is disconnected, or an incorrect line is attached. If you Silence this INOP, the measurement will be switched off.	Attach a FilterLine. Remember that only Microstream accessories may be used with the M3015A.
CO ₂ OCCLUSION (M3015A)	<ol style="list-style-type: none"> 1. The FilterLine or exhaust tube is blocked to the extent that a measurement sample cannot be taken, or 2. The outlet is occluded at Power On 3. This INOP also appears after the Pump Op Time is reset. 	<ol style="list-style-type: none"> 1. and 2. Check the FilterLine and exhaust tube, then disconnect and reconnect the FilterLine. If the INOP is still displayed, use a new FilterLine. 3. If Pump Op Time has been reset, perform a flow check and store the flow in Service Mode (select “Store Flow”).
CO ₂ OVERRANGE (M3015A)	The CO ₂ value is outside the measurement range.	
CO ₂ AUTOZERO	An AutoZero is in progress. An AutoZero will be done at the following intervals: 5 minutes after connecting the FilterLine, 1 hour later, 12 hours later, and every 12 hours from there on.	

<p>CO₂ PURGING</p>	<p>The Measurement Extension is purging the FilterLine. This occurs when an occlusion is detected in the line or airway adapter. If the occlusion is not removed by purging, the Measurement Extension will go into Standby Mode and a “CO₂ OCCLUSION” INOP will be displayed.</p>	<p>Check for an occlusion and remove. If necessary, replace the FilterLine.</p>
<p>NO CENTRAL MONITORING</p>	<p>Central monitoring has been interrupted.</p>	<p>With a wireless network: Check that the Monitor has not been moved out-of-range of an access point and that no microwave oven or other non-monitoring wireless device is interfering with the Monitor.</p>

Isolating the Defective Component

You can use the following table to isolate and solve problems which may occur in the Instrument.

Symptom	Cause of Failure	Remedy
System related problems		
The battery symbol is not displayed.	A battery is not present in the Monitor, the battery is defective, or there is a bad connection.	Install a charged battery. If a battery is already present, remove it and check the charge-level (press the button on the battery). Refit the battery making sure to push it completely into position.
Some or all numerics or waves are not displayed.	Parameters are switched off. No transducers are connected. Defective transducer. Unsupported server. Server defective.	Switch parameters on. Connect the required transducers. Replace the suspect transducer. Check for message: <i>No Measurements</i> or <i>Measurement Server Not Supported</i> . See previous remedy. Exchange the Server
Monitor screen appears dim.	Brightness not properly adjusted. Display backlight tubes worn.	Adjust brightness. Replace backlight tubes.

<p>Monitor screen is blank.</p>	<p>Power not connected or not switched on. Battery is not installed, is empty, or battery fuse is blown.</p> <p>AC Fuse is blown.</p> <p>Power supply defective.</p> <p>System board is defective.</p> <p>Poor connection to display.</p> <p>Display backlight tubes worn.</p> <p>Display defective.</p>	<p>Connect to AC power supply or fit charged battery and switch on the Monitor.</p> <p>Check and replace defective fuse (the Power Supply contains two fuses).</p> <p>Check if the AC power lamp on the front panel is on or off.</p> <p>Check System Board LEDs (see Troubleshooting the System Board LEDs).</p> <p>Check the ribbon-cable connection from the System Board to the Monitor Bezel</p> <p>Replace backlight tubes.</p> <p>Replace display.</p>
<p>Monitor screen is blank but the Instrument appears to boot as it should; alarm LEDs switch on/off, successful test sound, and yellow LED on the System Board blinks.</p>	<p>Display cable may be incorrectly seated. The display cable has two rows of connectors. It is possible (although extremely unlikely) that the connector has been fitted one row too high.</p>	<p>Refit the display cable making sure that the two rows of connectors fit together correctly. (It is mechanically not possible for a left/right misalignment).</p>

No response when touching or pressing the TouchStrip (or panel keys).	Poor connection between the TouchStrip and the System Board. Defective System Board.	Replace the front-panel Monitor Bezel. Replace the System Board.
All patient data is lost or corrupted (indicated in the error log).	Defective System Board. Data is stored on the connector board. If it is lost after 3 hours, the buffer is defective.	Go to the Service Mode and perform the extended test. If the extended test fails, replace the System Board. If a battery is in, remove it and put in new data. Replace the connector board and put in some patient data. If this does not correct the fault, replace the System Board.
Printing is not possible.	Defective printer. Infrared connection is not correctly aligned. Defective sender.	Try printing with another Monitor. Line-up the sender and receiver. Try another Monitor Bezel and replace if necessary. Check cable. Check/exchange the System Board.
No sound from Monitor.	Tone is switched low or off.	Switch Monitor off then on again. Tone should sound when Monitor first boots up. Check cable and connections to the speaker.
No marker pulse on screen. Out of sync ECG Analog Output	ECG Analog Output is defective. Defib sync input circuit is defective.	Replace the System Board. See ECG Sync Performance Test.

<p>Incorrect Time Stamps</p> <p>Invalid data stored showing wrong times for data.</p>	<p>The Instrument's real time clock is defective.</p>	<p>Power on for a few minutes then reset the time and date.</p> <p>Replace the System Board.</p>
<p>Cannot reprogram the time and date correctly</p>	<p>Defective System Board.</p>	<p>Replace the System Board.</p>
<p>Compatibility related problems</p>		
<p>“Some measurements are not supported by the Monitor” prompt message</p>	<p>A measurement extension (M3015A or M3016A) is connected to an M3046A M3 monitor. No measurements (CO₂, 2nd Press/Temp) from the Measurement Extension are available.</p>	<p>Use extensions only with M3046A M4 monitors</p>

<p>“Measurement Server Configuration not supported” status message</p>	<p><i>Either</i> A Measurement Extension (M3015A or M3016A) is connected to a standard M3000A Measurement Server (noninvasive measurements only) and an M3046A Monitor with software Rev.D or lower. No measurements (CO₂, 2nd Press/Temp) from the Measurement Extension are available.</p> <p><i>Or</i> A Measurement Extension (M3015A or M3016A) is connected to a standard M3001A Measurement Server (noninvasive measurements only) and an M3046A Monitor with software Rev.E . No measurements (CO₂, 2nd Press/Temp) from the Measurement Extension are available.</p>	<p>Use extensions only with Extended Measurement Servers (#C06 for M3000A; #C06 and #C18 for M3001A).</p>
<p>“Some measurements in MMS Extension are not supported” prompt message</p>	<p>The M3046A Monitor does not support some of the measurements in a Measurement Extension.</p>	

<p>“Measurement Server not supported” status message</p>	<p><i>Either</i> M3001A Measurement Server is connected to an M3046A Monitor with Rev. D or lower software. This combination does not allow monitoring. <i>Or</i> M3000A Measurement Server is connected to an M3046A Monitor with Rev. E software. This combination does not allow monitoring.</p>	<p>Use only M3000A Measurement Servers with M3046A Monitors with Rev. D or lower software. Use only M3001A Measurement Servers with M3046A Monitors with Rev. E software.</p>
<p>Power Supply related problems</p>		
<p>See Troubleshooting the Front-Panel LEDs earlier in this chapter.</p>		
<p>Display and LCD Adapter Board related problems</p>		
<p>Monitor screen is blank.</p>	<p>Instrument appears to boot as it should; alarm LEDs switch on/off, successful test sound, and yellow LED on the System Board blinks. Display and other cables not seated correctly.</p>	<p>See Troubleshooting the System Board LEDs earlier in this chapter. Refit cables correctly. If this does not work, replace the LCD Display Assembly.</p>
<p>Fluid dripping or appearing below Instrument.</p>	<p>LCD assembly damaged or cracked.</p>	<p>Replace the LCD Display Assembly.</p>
<p>Decrease in light intensity on display. Brightness decreases from top to bottom or bottom to top.</p>	<p>One of the two backlight tubes is worn.</p>	<p>Replace both backlight tubes. Although it is unusual for both tubes to need replacing at the same time, you are recommended to do so since replacement is not easy.</p>

Display waves are noisy/not showing a smooth QRS wave.	Radio frequency interference (RFI) from other instruments such as ultrasound, ESU, Defib, or telemetry is causing noisy waveforms.	Turn off or move away from the Monitor the instrument causing RFI problems.
Message appears: New display detected, please enter new display specs”	The display has been exchanged and the Monitor needs the new specifications.	Use the Upgrade Tool to upgrade the monitor with the latest display specifications.
TouchStrip related problems		
TouchStrip discolored, cracked or surface is deformed.	Cleaning agents, abrasive material, or strong solvents were used to clean the Instrument.	Replace the Monitor Bezel and clean the Instrument in the future with only isopropyl alcohol. Wipe cleaning agents off surfaces immediately.
Lack of user control of display.	Cable from the System Board to the Monitor Bezel not connected properly. Defective TouchStrip. Defective System Board.	Refit cable correctly. Check Status Log for message: CHECK INPUT DEVICE Replace the System Board.
Network related problems		
“No Central assigned to this bed” prompt message	Wrong monitor label or Information Center incorrectly configured	Check the bed assignments at the Information Center and that the monitor label assigned to this monitor has not been changed locally

<p>“No Central - duplicate monitor label” prompt message</p>	<p>Monitor label configuration is in conflict with another monitor</p>	<p>Check that the monitor label assigned to this monitor has not been changed locally. Check the assignment at the Information Center</p>
<p>“Assigned Central is not available” prompt message</p>	<p>The Information Center is switched off or not accessible</p>	
<p>“No Central - software incompatible” prompt message</p>		<p>Ask Biomed department to check software revisions.</p>
<p>“Central can not identify this bed” prompt message</p>	<p>The location of this bed is not clear.</p>	<p>Check the bed assignments at the Information Center.</p>
Measurement Server related problems		
<p>No waves.</p>	<p>Measurement Server defective. LEDs on display unit blink but Server LED does not.</p>	<p>Check green LED on Server. Exchange the Server. Connection between the Server and the display is lost. Exchange the Server.</p>
<p>No ECG data or waveform displayed when both defib sync and balloon pump are done together.</p>	<p>2-circuit cable used in a 3-circuit ECG output jack.</p>	<p>Use a bud box when setting up ECG.</p>

Red ECG LED is on.	System Board is defective. Defib. synchronization is not in sync. with ECG. Defib. synchronization fails.	Replace the System Board. Exchange the Server and try again. Check the defib. cable.
SpO ₂ values appear unstable or unreliable	Low light transmission of SpO ₂ sensor LEDs to the sensor photo diode. Patient has low peripheral perfusion	Check Transmission and Perfusion Index as follows: 1) Fit SpO ₂ sensor on your finger 2) Enter Config Mode 3) Select SpO ₂ . 4) Switch SpO ₂ On Lightly press the Touch-strip until text appears at the bottom of the screen: Perfusion Index xx.x Transm. red yyyy Transm. infra red zzzz The Perfusion Index should be > 1 and both Transmission indexes should be greater than 10.

Sidestream CO₂ Measurement Server Extension related problems		
No wave displayed and no channel present	<p>1.Measurement Extension is used with a monitor and/or Measurement Server with Release A software (A.xx.xx)</p> <p>2.CO₂ Data Acquisition hardware is incompatible with wireless network (major revision number <10 and minor revision number <30) and Measurement Server Extension is used on a monitor with wireless network option.</p> <p>3.No FilterLine attached</p> <p>4.CO₂ measurement switched off</p> <p>5. Pump defective</p> <p>6. Incorrect or defective FilterLine</p>	<p>1. Check if the measurement extension is supported by the system configuration (hardware and software). Check that no “UPDATE FW” message is displayed.</p> <p>2. Check CO₂ Data Acquisition hardware revision. If the Measurement Server Extension is incompatible with wireless network either use this Measurement Server Extension on a monitor without wireless network or upgrade the Measurement Server Extension (contact your service representative).</p> <p>3. Check that a FilterLine is connected.</p> <p>4. Check that CO₂ measurement is switched on.</p> <p>5. Check whether the pump is running.</p> <p>6. Replace the FilterLine and check again.</p>
Accuracy problems	<p>Incorrect N₂O setting</p> <p>Incorrect humidity correction setting (BTPS/STPD)</p> <p>Incorrect Max Hold setting</p> <p>Invalid calibration</p>	<p>1. Check settings:</p> <ul style="list-style-type: none"> - N₂O correction - BTPS or STPD - Max Hold or standard averaging <p>2. Perform accuracy check and calibrate, if necessary.</p>

No wave displayed but channel is present		Check for INOPS and follow recommended actions
Mainstream CO₂ Measurement Server Extension related problems		
“CHECK CAL” INOP	Invalid calibration	Follow the recommended actions from INOP table
Accuracy problems	Incorrect N ₂ O setting Incorrect humidity correction setting (BTPS/STPD) Incorrect Max Hold setting Invalid calibration	1. Check Settings: - N ₂ O correction - BTPS or STPD - Max Hold or standard averaging 2. Perform accuracy check on calstick and calibrate, if necessary.
No wave displayed and no channel present	1.Measurement Extension is used with a monitor and/or Measurement Server with Release A software (A.xx.xx) 2.CO ₂ measurement switched off	1. Check if the Measurement Extension is supported by the system configuration (hardware and software) 2. Check that CO ₂ measurement is switched on
Audio Speaker related problems		
Buzzing noise accompanying alarm, INOP, or QRS sound.	Speaker mounting problem, for example, the speaker is ajar due to being dropped.	Mount speaker properly or replace speaker.
No tone alarms. Speaker will not work.	Make sure audible tones are switched on. Cable disconnected. Defective speaker. Defective Audio Circuit.	Reconnect cable. Replace speaker. Replace the System Board.

Buzzing noise in Instrument.	Defective Audio Circuit. Defective Power Supply.	Replace the System Board. Replace the Power Supply.
---------------------------------	---	---

Recorder Problems (refer also to the <i>Operator's Manual</i> of the XE-50p Chart Recorder)		
Message	Meaning	Action
“Local Recorder Malfunction” prompt message	Command error: <ul style="list-style-type: none"> • Syntax error in either the Recorder or Monitor software. • Intermittent connection to Recorder or faulty cable. 	Software problem, not correctable in the field. Replace the Recorder. <ul style="list-style-type: none"> • Check cable connection is secure between the Monitor and the Recorder. • Check cable, and replace if necessary.
	Recorder hardware fault detected.	Replace the Recorder.
“Local Recorder check cable” prompt message	Communication error: <ul style="list-style-type: none"> • Intermittent connection to Recorder or faulty cable. • Frame error in RS232 protocol (due to a connection problem or effects of interference from external electrical equipment, such as fluorescent lighting). 	<ul style="list-style-type: none"> • Check cable connection is secure between the Monitor and the Recorder. • If connection is sound, but the problem persists, replace the cable. • Check cable connection is secure between the Monitor and the Recorder. • If connection is sound, but the problem persists, replace the cable. • If there is electrical interference from external equipment, try to isolate the cause, and if possible repair or remove the cause of the interference.

“Local Recorder door open” status message	Recorder door is open. The Recorder is available, but is not ready for recording.	Close the door.
“Local Recorder out of paper” status message	The Recorder is out of paper. The Recorder is available, but is not ready for recording.	Load paper into the Recorder (refer to the <i>Operator’s Manual</i> for the XE-50p Chart Recorder for details.
“No Local Recording (Printhead Temperature)” status message	The printhead is too warm (> 68°C).	Switch off the Recorder and allow it to cool down for a few minutes, then try again. If the problem persists, replace the Recorder.
	The printhead is too cold(< 0°C). (For instance, the Recorder may have been transferred from storage, where the temperature was below 0°C).	The ambient temperature in the room where the Recorder is used should be above 0°C. Allow the Recorder to warm up for a few minutes, then try again. If the problem persists, replace the Recorder.
“Local Recorder disconnected” status message	The Recorder is disconnected from the Monitor or switched off	<ul style="list-style-type: none"> • Ensure the Recorder cable is securely connected to the sockets on the Monitor and on the Recorder. • Ensure that the Recorder is switched on.
“Local Recorder connected”	The Recorder is connected and available.	
“No local alarm recording available” status message	Local alarm recording has been selected, but the Recorder is not available.	Ensure that the Recorder is switched on and connected to the Monitor.

Part 3 Using Support Functions

There are various support functions available in the monitor to assist in fault diagnosis. These are described below. If diagnostic and error information is to be communicated to Philips, this should always be associated with a particular instrument by means of the serial number. The serial numbers for the Monitor and the Measurement Server can be seen in the “Revisions” window (press Setup key then select “Revisions”). However, if a Measurement Server Extension (M3015A or M3016A) is in use, the number will not appear and must be noted down from the back of the Extension. To do this, remove the Measurement Server and Extension from the Monitor, so that the back of the extension is visible.

The Status Log and Error Codes

One possible line of fault isolation is in the **error codes**. However, some error codes cannot provide diagnostic information at the repair site and must be analyzed in the factory **if they appear repeatedly**. Whenever one of the subsystems is unable to perform an operation, an error code is generated. Error codes are assigned to fatal and non-fatal errors.

Error codes can be found in the **Status Log** while in the operating modes. In the Configuration, Demonstration, and Monitoring modes, the Status Log only displays fatal error codes. In the Service Mode, the Status Log displays both fatal and non-fatal error codes with a blank line separating the two.

Errors that occur during start-up or regular monitoring are logged in the Status Log. The Status Log can be printed and cleared. If fatal errors occur **repeatedly**, send a printout of the Status Log (Service Mode) to Philips.

There are two categories of error:

Fatal Errors—These errors indicate major problems that cause the Monitor to reset and restart. These types of errors might force the Monitor to go back to user defaults. Fatal errors usually point to a defective System Board. This will be reported to the user by the INOP alarm: CHECK STATUS LOG. The fatal error can be reviewed in the Status Log menu. After the Status Log is reviewed, the INOP is removed.

If a fatal error occurs which cannot be diagnosed, download the Status Log into a file using the M3 Support Tool and send it to the Technical Marketing department at Philips Medical Systems.

Non-Fatal Errors—These indicate general errors that are not significant enough to affect normal Monitor operation. Non-fatal errors are errors that give some hints about an unexpected behavior of the system but that are not relevant to correct system function. They do not cause the Instrument to reset or restart. They are not reported during monitoring but can be seen in the Status Log if the Monitor is in Service Mode.

Monitor, Measurement Server and Measurement Server Extension errors are reported separately in the Status Log.

The following table explains the contents of the Status Log. The first entry on the left side of the Status Log corresponds to the top entry under Field Title in the table.

Field Title	Description
H, C, or N	H and C—These denote fatal errors which have caused a H ot start (like switching the Instrument off/on) or a C old start (like performing a System Test). N—This denotes a non-fatal error.
Device ID Code	This number refers to a software module, and is used to indicate the location of a fault.
<i>n</i>	This number is the internal software module number.
Error Code	This number describes the type of fault identified.
Date/Time	This indicates the date/time the error occurred.

List of Error Codes

If a code labelled **Software Condition** occurs once, it requires no action. If it occurs repeatedly, pass the information on to your Philips representative for analysis. When reporting an error code, always provide information on the monitor revision, the number of instances the code appears in the status log, and any symptoms or problems seen on the monitor.

Table 1: Error Codes for Release A

Severity	Device ID	Error Code	Information / Action required
M3046A Monitor			
N	17205	20005	Software Condition
N	17205	20009	Software Condition
N	17205	20012	Software Condition
N	17205	20058	Software Condition
N	17205	20500	Software Condition
N	17205	20553	Software Condition
N	17205	20601	Software Condition
N	17216	20050	Software Condition
N	17250	20642	Software Condition
N	17315	22043	Software Condition
N	17316	12000	Software Condition
N	17316	12100	Software Condition
H	16400	610	Software Condition
H	16400	941	Software Condition
H	17250	20005	Hardware failure, replace system board
M3000A Measurement Server			
N	16400	2130	Software Condition
N	16400	2131	Software Condition
N	16400	2132	Software Condition
N	16400	2133	Software Condition
N	17203	20705	Software Condition
N	17203	20601	Software Condition
N	17203	20667	Software Condition

Table 1: Error Codes for Release A

Severity	Device ID	Error Code	Information / Action required
N	17300	20046	Software Condition
N	17300	20106	Software Condition
N	17300	20134	Software Condition
N	17300	20302	Software Condition
N	32753	24584	Software Condition
N	32753	24592	Software Condition
N	32765	20709	Software Condition
N	32765	20713	Software Condition
N	32767	20002	Software Condition
H	16400	118	Hardware Failure, replace Server
H	16400	133	Hardware Failure, replace Server
H	16400	591	Hardware Failure, replace Server
H	16400	592	Hardware Failure, replace Server
H	17203	20102	Hardware Failure, replace Server
H	17206	20015	Hardware Failure, replace Server
H	17300	20107	Software failure, upgrade to revision B
H	32753	28672	Hardware Failure, replace Server

If a code labelled Software Condition occurs once, it requires no action. If it occurs repeatedly, pass the information on to your Philips representative for analysis

Table 2: Error Codes for Release B

Severity	Device ID	Error Code	Information/Required Action
M3000A Measurement Server			
N	17300	20001	Software Condition
N	17300	20046	Software Condition
N	17300	20047	Software Condition
N	17300	20088	Software Condition
N	17300	20101	Software Condition
N	17300	20121	Software Condition

Table 2: Error Codes for Release B

Severity	Device ID	Error Code	Information/Required Action
N	17300	20139	Software Condition
N	32753	22450	Software Condition
N	32765	20514	Software Condition
N	32765	20702	Software Condition
N	32765	20714	Software Condition
N	32765	20715	Software Condition
H	16400	562	Software Condition
H	17203	20058	Software Condition
H	17300	20002	Software Condition
H	17300	2009x	Software Condition
H	17300	20307	Results from an upgrade to another monitor option, no action required
C	32749	20002	Measurement Extension has been exchanged, no action required
M3046A Monitor			
N	16510	20337	Software Condition
N	17205	20050	Software Condition
N	17205	20058	Software Condition
N	17205	20650	Software Condition
N	17205	20664	Software Condition
N	17206	20010	Software Condition
N	17215	21480	Software Condition
N	17215	21580	Software Condition
N	17250	20502	Software Condition
N	17250	20525	Software Condition
N	17303	21104	Software Condition
N	17315	20010	Software Condition
N	17315	20014	Software Condition
N	17315	20016	Software Condition
N	17316	20004	Software Condition

Table 2: Error Codes for Release B

Severity	Device ID	Error Code	Information/Required Action
N	17316	20010	Software Condition
N	17317	22073	Software Condition
N	32764	20007	Software Condition
H	16400	100	Software Condition
H	16400	562	Software Condition
H	17303	20210	Software Condition
H	17303	20707	Can occur during upgrades, no action required
H	17305	20058	Software Condition
H	32750	21400	Software Condition

Table 3: Error Codes for Release C

Severity	Device ID	Error Code	Information/Required Action
M3000A Measurement Server			
H	17300	20096	Software Condition
H	17300	20307	Can occur during or after upgrades, no action required
M3046A Monitor			
N	16510	20337	Software Condition
N	17205	20014	Software Condition
N	17205	20505	Software Condition
N	17205	20604	Software Condition
N	17303	20000	Software Condition
N	17303	20006	Software Condition
N	17303	20703	Software Condition
N	17303	20803	Software Condition
N	17303	20810	Software Condition
N	17303	21104	Software Condition
N	17315	20080	Software Condition
N	17315	22042	Software Condition

Table 3: Error Codes for Release C

Severity	Device ID	Error Code	Information/Required Action
N	17316	20004	Software Condition
N	17316	20010	Software Condition
N	17316	20011	Software Condition
N	17316	20015	Software Condition
N	32764	20007	Software Condition
N	32764	20009	Software Condition
N	32674	20010	Software Condition
H	16400	100	Software Condition
H	16400	133	Software Condition
H	16400	941	Software Condition
H	17205	20102	Software Condition
H	17205	20666	Software Condition
H	17305	20008	Software Condition
H	17305	30056	Software Condition
H	17215	22002	Software Condition
H	17215	22060	Software Condition
H	32750	21400	Software Condition
H	32750	21224	Software Condition

Table 4: Error Codes for Release D

Severity	Device ID	Error Code	Information/Required Action
M3046A Monitor			
N	17312	20064	Software Condition
N	17315	20016	Software Condition
H	16400	611	Software Condition
H	17207	20009	Software Condition
H	16400	235	Software Condition (see FCO 86200134 and FCO 86200185)
H	16400	502	Software Condition (see FCO 86200185)

Testing Wireless Network Connectivity

Using the Site Survey Tool¹ you can check the antenna functionality.

Antenna Check

This test gives a Received Signal Strength Indication (RSSI) and will indicate if the antenna is in order.

Setup

- 1 The M3046A should be approximately 15 feet away from the test PC.
- 2 Configure the Wireless LAN assembly of the M3/M4 and the Site Survey & Configuration Tool for the same Domain and Security ID. Configure using the Wireless Configuration Tool available on the Philips Information Center CD-ROM.
- 3 Check that the RangeLAN2 Site Survey and Configuration tool is running (if not, double click on the RangeLAN2 Configuration Icon to start it).
The main window appears as shown below:

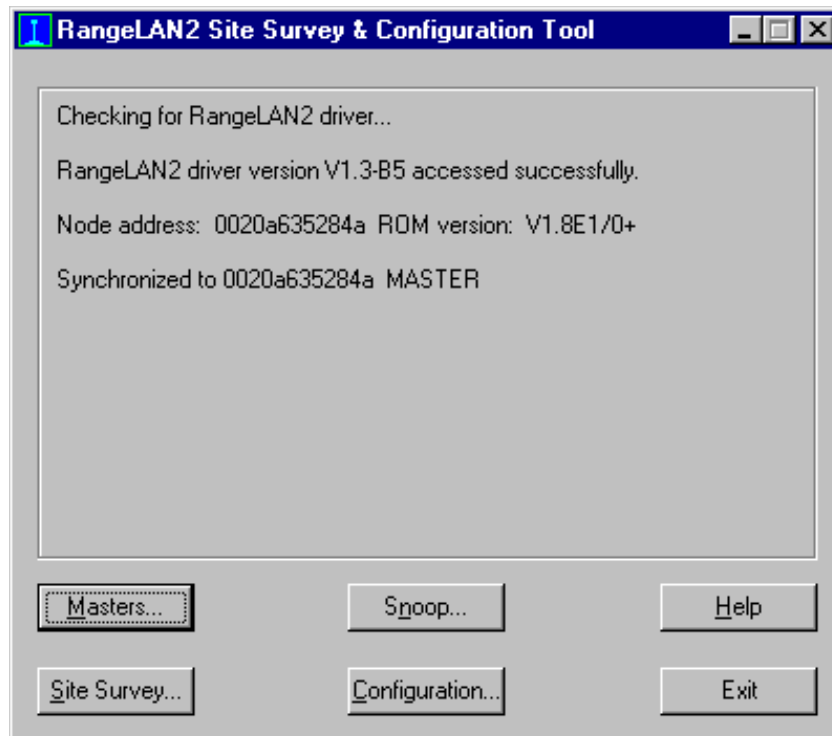

1. The recommended Site Survey Tool is available from Connectronics (www.connectronics.com). The part number is 82-6332 7402-05, Range LAN2/PCMCIA Card (One-piece with Snap-on antenna).

Procedure

- 1 Click on the Site Survey button in the main window to bring up the Site Survey window, which appears as shown below:

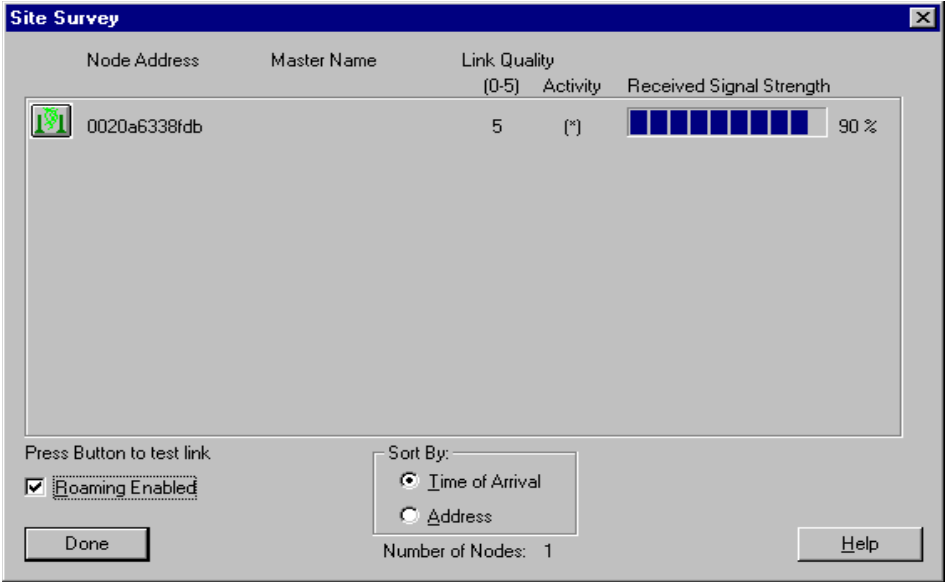

In this example, the Node Address shows one unit (this is the MAC address of the radio board 0020a6338fdb) with a Received Signal Strength of 90%. The number to the right of the bar graph is the indicator.

Acceptance Criteria:

The RSSI should be greater than 80%. If it is less than 80%, check the antenna cable connection to the Radio board inside the M3046A to see that it is mated properly.

When the test is completed, click on Done in the Site Survey window, then on Exit in the RangeLAN2 Site Survey and Configuration Tool window.

Using Service Mode

Service Mode Hardware Tests

The tests described below are accessible in Service Mode only. In Service Mode press the **Setup** key and select **Hardware Test** to display the Hardware Test selection menu.

Coldstart Test

CAUTION

Before executing a coldstart test be aware that the patient database will be erased by the test and that the Monitor defaults will be reset to user defaults.

This coldstart test executes a reboot with a more intensive system Self-Test than a normal reboot. The coldstart test is also executed in the Server and in the Extension if either one is connected.

Executing the coldstart test automatically returns the Instrument to Monitoring Mode.

To execute a coldstart test, do the following:

- Step 1** Switch the Monitor into Service Mode.
- Step 2** Press the Setup key.
- Step 3** Select Status Log.
- Step 4** Clear the Status Log and Confirm (for both, Monitor and Server).
- Step 5** Press Exit.
- Step 6** Select Hardware Test.
- Step 7** Select Coldstart.
- Step 8** Press Confirm.

The Monitor (and Server, if connected) perform a reboot.

The coldstart reboot is the same as described in What Happens During a Regular Boot, AC powered, without Battery *except* that the time taken from the switch off of the Alarm and Suspend LEDs to the switch on of the backlight and display of the M3 logo is extended. The whole reboot takes about 10 seconds.

After the system has come up again, check whether a CHECK STATUS LOG INOP is displayed.

- If not, the test is successful.
- If yes, do the following:
 - Go into the Status Log and check whether either the Monitor or the Server reports a fatal error.

- Print out the Status Log in which the error is reported.

To ensure the fault is not a single (sporadic) fault, you should rerun the coldstart sequence (including clearing the Status Logs).

- If a fatal error is again reported, either the System Board or the Server should be replaced. Please include the printed Status Log with the exchanged parts.

Display Test

This test is a non-destructive, visual test of the SGRAM video memory. From left to right, top to bottom a small square consisting of colored bars moves over the whole screen during approximately 30 seconds. During this test, the memory content of the video display (consisting of small blocks of memory) is read into other memory and stored. Then the memory blocks are filled with a colored bar pattern, cleared again, and then recovered with the previously stored data. The tested display then reverts to the pre-test state.

The test continues until either it is switched off or Service Mode is exited.

Success—The test is *passed* if the display has reverted to the pre-test state once the test has passed over the whole screen once. (Be aware that numerics are updated also during a running display test. This should not be considered a fault.)

Failure—The test is *failed* if the display has not reverted to the pre-test state once the test has passed over the whole screen once. If the test fails, repeat the test to make sure that it is not a single (sporadic) fault. If it fails again, exchange the System Board.

The advantage of this test compared to the SGRAM video memory test executed in the coldstart test is that the patient database is not erased and the active default set is not reset to user defaults.

Backlight Test

The cumulative time the backlight has been operating is shown. When replacing backlight tubes, this counter must be reset. A reset of the backlight time must be confirmed.

If the backlight tubes have been on for an estimated time of typically 25 000 hours, brightness might be reduced by about half and the tubes should be replaced. Since the reduction of effective brightness depends on a number of factors, the decision to replace the tubes should be determined on a case by case basis rather than the total number of operating hours. Examples of factors that contribute to reduced backlight brightness are as follows:

- Cumulative operating hours.
- Operating-interval time or user-set brightness level.

Reset PumpOpTime

The cumulative time the pump in the M3015A Measurement Server Extension (sidestream CO₂) has been operating is shown. When replacing the pump (*applies to units with serial number prefix DE020xxxxx only*), this counter must be reset. A reset of the pump time must be confirmed.

NOTE

When the PumpOpTime has been reset an INOP will be generated: “CO₂ OCCLUSION”. To clear this INOP you must perform a flow check and store the flow in Service Mode (select “Store Flow”)

The effectiveness of the Pump gradually decreases over time. As a result, periodic replacement is necessary (*applies to units with serial number prefix DE020xxxxx only*).

Philips recommends replacement of the Pump as follows:

- After 15,000 to 20,000 hours (max 20 000 hours).
- If the flow cannot be adjusted to the desired value.
- If the Pump makes considerably more noise than new Pumps.

After replacing the pump, perform a CO₂ calibration check as described in “CO₂ Gas Measurement Calibration Check” on page 152.

When replacing the pump in the M3015A Measurement Server Extension (sidestream CO₂), you should also replace the CO₂ scrubber at the same time.

Recorder Status Check

You can check the status of the recorder by entering Service Mode, then pressing the Local Record SmartKey . The firmware version (FV), voltage (V), and temperature at the printhead (T) are printed out:



FV4.1
V11.9
T+36

Self-Test Cycles (information only)

The number of executed Self-Test cycles since the last reboot is displayed, but cannot be modified.

OpTime Mon (information only)

The cumulative time that the Monitor has been operated is shown, but cannot be modified.

OpTimeMeasS (information only)

The cumulative time the Measurement Server has been operated is shown, but cannot be modified.

NBP Cycles: (information only)

The cumulative number of NBP cycles completed is shown, but cannot be modified.

Line Frequency

When operating on mains power supply, the line frequency indication is used to switch between 50 Hz and 60 Hz for the ECG filtering frequency.

CAUTION

Make sure that the Line Frequency is set correctly for the country option ordered. The factory default is 60 Hz for all units regardless of country option.

How To Access the Monitor and Server Revision Screen

- 1 Press **Setup**.
- 2 Move the highlight to **Revision**.
- 3 Depending on which screen you want to display, toggle between **Monitor Revision** and **MeasServ Revision**.

Troubleshooting the Installed Instrument

Here is a list of some easily corrected troubleshooting cases. If the fault is not described below, investigate further without delay. For more information, see "Testing the Instrument" and "Repairing the Instrument".

Troubleshooting with Self-Test Alarm Messages (When You Switch the Monitor On)

Message	What To Do
Battery Low (approximately 20 minutes remaining)	Connect to AC power to charge the battery, or fit a fully charged battery within next 15 minutes.
Check Status Log	This indicates a non-critical problem in the Monitor. There is a defect but the Monitor can still be used. The Monitor should be investigated technically, however, as soon as possible.
ECG EQUIP MALF	Measurement defective. Exchange the Measurement Server. The Measurement Server should be investigated technically as soon as possible.
NBP EQUIP MALF	Measurement defective. Exchange the Measurement Server. The Measurement Server should be investigated technically as soon as possible.
Pressure Zero & Check Cal	Pressure must be zeroed, or calibration required. Zero the Pressure, or check the calibration. If unsuccessful, exchange the Measurement Server.
PRESS EQUIP MALF	Measurement defective. Exchange the Measurement Server or Measurement Server Extension. The Measurement Server or Measurement Server Extension should be investigated technically as soon as possible.
RESP EQUIP MALF	Measurement defective. Exchange the Measurement Server. The Measurement Server should be investigated technically as soon as possible.

Message	What To Do
SpO ₂ EQUIP MALF	<p>Measurement defective. Exchange the Measurement Server.</p> <p>The Measurement Server should be investigated technically as soon as possible.</p>
TEMP EQUIP MALF	<p>Measurement defective. Exchange the Measurement Server or Measurement Server Extension.</p> <p>The Measurement Server or Measurement Server Extension should be investigated technically as soon as possible.</p>
CO ₂ EQUIP MALF	<p>Measurement defective. Exchange the Measurement Server Extension or (for mainstream CO₂) the transducer.</p>
BAD SERVER LINK	<p>You cannot use this combination of Monitor, Measurement Server and cable.</p> <p>Switch off the monitor and contact your biomedical department.</p>
BAD SERVER LINK plus “Measurement Server Revision not supported” status message in red.	<p>An M3000A Measurement Server with revision A software is connected to an M3046A Monitor with a software revision of B or later. This combination does not allow monitoring.</p>
“Some measurements are not supported by the Monitor” prompt message	<p>A measurement extension (M3015A or M3016A) is connected to an M3046A M3 monitor.</p> <p>No measurements (for example CO₂, 2nd Press/Temp) from the Measurement Extension are available.</p> <p>If the extra measurements <i>are</i> required, consider using a monitor that supports these measurements.</p>

Message	What To Do
<p>“Measurement Server Configuration not supported” status message</p>	<p><i>Either</i> A Measurement Extension (M3015A or M3016A) is connected to a standard M3000A Measurement Server (noninvasive measurements only) and an M3046A Monitor with software Rev.D or lower. No measurements (for example CO₂, 2nd Press/Temp) from the Measurement Extension are available. Exchange the Measurement Server for an M3000A with option #C06.</p> <p><i>Or</i> A Measurement Extension (M3015A or M3016A) is connected to a standard M3001A Measurement Server (noninvasive measurements only) and an M3046A Monitor with software Rev.E . No measurements (for example CO₂, 2nd Press/Temp) from the Measurement Extension are available. Exchange the Measurement Server for an M3001A with option #C06 or #C18.</p>
<p>“Some measurements in MMS Extension are not supported” prompt message</p>	<p>The M3046A Monitor does not support some of the measurements in a measurement extension. Consider using a monitor that supports these measurements.</p>
<p>“Measurement Server not supported” status message</p>	<p><i>Either</i> M3001A Measurement Server is connected to an M3046A Monitor with Rev. D or lower software. This combination does not allow monitoring. Use only M3000A Measurement Servers with M3046A Monitors with Rev. D or lower software.</p> <p><i>Or</i> M3000A Measurement Server is connected to an M3046A Monitor with Rev. E software. This combination does not allow monitoring. Use only M3001A Measurement Servers with M3046A Monitors with Rev. E software.</p>

Troubleshooting When There is No Message on the Screen

Symptom	Possible Cause	What To Do
Some or all of the numerics or waves are missing from the screen.	No measurements connected	Check that a Measurement Server and all the required transducers are connected. Connect a Measurement Server.
	No transducers connected	Connect the required transducers.
	Defective transducer	Replace the suspect transducer.
	Measurement Server defective	Exchange the Measurement Server. The Measurement Server should be investigated technically as soon as possible.
Monitor screen dim	Brightness controls not properly adjusted	Adjust brightness controls. The screen may not be as bright when the Monitor is operating from the battery.
Monitor screen blank	Power is not connected or switched on	Connect power and switch on the Monitor.
	Battery not installed or empty (Battery LED flashes red, or flashes red when you press the On-Off/Standby switch.)	Fit a charged battery and switch on the Monitor.

Troubleshooting During/After a Software Upgrade

Message	What To Do
“No Link Bar detected, please apply”	The service Link Bar must be directly connected to the Measurement Server. Make sure that no Measurement Extension (M3015/16A) is attached and that the Measurement Server is not attached by cable to the Link Bar
“Please remove service Link Bar after service”	The service Link Bar has been left connected, reconnect the standard link bar before continuing
Error codes 20210, 20307, 20002, 20102, 206nn,20nnn.	Several error codes will occur as a result of an upgrade and do not require any action. In order to assess which codes result from an upgrade you should always check and clear the status log before starting an upgrade. When the upgrade is complete, recheck the status log and clear before normal operation is resumed

Troubleshooting the Printer Connection

Here is a list of some easily corrected troubleshooting cases. If the fault is not described below, investigate further as soon as possible. For more information, see "Testing the Instrument" and "Repairing the Instrument".

Message	What To Do
You cannot find the print softkeys, or the Print Screen SmartKey is inactive.	Make sure that the printer is configured (see Connecting a Printer in "Installing the Instrument").
You do not get a printout.	If printing via an infrared link— Make sure that the printer is connected to the JetEye. Make sure that the JetEye is positioned properly at the side of the Monitor (see Installing the Wireless Infrared Printer Connector (M3080A #H05) in "Installing the Instrument"). Make sure that both the JetEye and the printer are switched on.

	<p>If printing via a network link— Make sure that the printer is connected to the Philips LAN or the M3 Print Server^a network (see Connecting a Remote Printer in "Installing the Instrument"). Make sure that the printer is switched on.</p>
Data is missing from a print-out and the printout is at lower resolution than normal	<p>The laser printer was switched off, but the Jet-Eye was left on. This results in the described behaviour. Users should be advised always to switch the printer and Jet-Eye off together.</p>
Your printout is too big for the page:	<p>This can happen if the JetEye is switched on but the printer is switched off when you start printing. Make sure both the printer and, if necessary, the JetEye are switched on, then print again.</p>
A REMOTE PRINTER NOT AVAILABLE message appears on the screen:	<p>Check that the Monitor is connected to the Philips LAN or the M3 Print Server^a network. If it is not, connect it (see Connecting a Remote Printer in "Installing the Instrument"). If it is connected, contact the M3 Print Server system administrator^b.</p>
The printout does not appear at the network printer but there is no error message at the Monitor:	<p>Check that the network printer is switched on and not in an error condition. If it is both switched on and in an error-free condition, contact the M3 Print Server system administrator.^b</p>

- a. No longer available.
- b. If applicable.

Troubleshooting the Recorder Connection

Here is a list of some easily corrected troubleshooting cases. See also page 195, and the *Operator's Manual* of the XE-50p Chart Recorder.

Message	What To Do
You cannot find the record softkeys.	Make sure that the Recorder is configured (see "Connecting a Local Recorder" on page 96).

<p>You do not get a printout, and the green Power LED does not light.</p>	<ul style="list-style-type: none"> • Check cable connection is secure between the Monitor and the Recorder. • If connection is sound, but the problem persists, replace the cable. • Make sure that the printer is switched on. • Check that the fuses are intact and that the fuse drawer is properly and completely inserted.
<p>You do not get a printout, and the green Power LED is lit.</p>	<ul style="list-style-type: none"> • Check if the Monitor power is on. • Check the cables between the Monitor and the Recorder. • Check if the Recorder is out of paper. • Check if there are any paper scraps caught under the print head.
<p>Paper moves but Recorder does not print.</p>	<ul style="list-style-type: none"> • Paper is incorrectly loaded.
<p>“Local Recorder disconnected” message appears on the screen:</p>	<p>The Recorder is disconnected from the Monitor, or switched off. Ensure that the Recorder cable is securely connected to the sockets on the Monitor and on the Recorder, and that the Recorder is switched on.</p>
<p>“Local Recorder Malfunction” prompt message</p>	<p>Recorder hardware fault. Replace recorder.</p>
<p>“Local Recorder chaeck cable” prompt message</p>	<ul style="list-style-type: none"> • Check cable connection is secure between the Monitor and the Recorder. • If connection is sound, but the problem persists, replace the cable. • If there is electrical interference from external equipment, try to isolate the cause, and if possible repair or remove the cause of the interference.

Tutorial for Troubleshooting the Instrument

Question 1: According to this chapter, what troubleshooting support functions are built-in to the Instrument?

- a. The Status Log and error codes are the only built-in troubleshooting support functions.
- b. The Coldstart Test, Display Test, Backlight Test, Reset PumpOpTime, Reset IRSourceTime, Self-Test Cycles, OpTimeMon, OpTimeMeasS, and NBP Cycles are the only built-in troubleshooting support functions.
- c. The Status Log, error codes, Coldstart Test, Display Test, Backlight Test, Reset PumpOp Time, Reset IRSourceTime, Self-Test Cycles, OpTimeMon, OpTimeMeasS, and NBP Cycles are all built-in troubleshooting support functions.

Question 2: Which of the following support functions display information only (either operating time or number of cycles for parts or features of the Instrument) and cannot be modified?

- a. The Self-Test Cycles, OpTimeMon, OpTimeMeasS and NBP Cycles are selections which display this type of information and cannot be modified.
- b. The Coldstart Test, Display Test, Reset PumpOpTime, Reset IRSourceTime and Backlight Test display this type of information and cannot be modified.
- c. The Line Frequency indicator displays this type of information and cannot be modified.
- d. None of the above examples are correct.

Question 3: There are LEDs available for visual observation during troubleshooting. Where are they located?

- a. On the front panel.
- b. On the Measurement Server.
- c. On the System Board in the M3046A, visible from the rear of the monitor.
- d. On the M3046A located on the bottom of the monitor.
- e. a. b. and c.

Question 4: Non-fatal error codes are only available in:

- a. Monitoring Mode
- b. Configuration Mode
- c. Service Mode
- d. Operating Mode

Answers to the Tutorial for Troubleshooting the Instrument

- 1) c. (See page 197 for more details.)
- 2) a. (See page 208 for more details.)
- 3) e. (See pages 5-2 to page 175 for more details.)
- 4) c. (See pages 197 for more details.)

6 Repairing the Instrument

Objectives

To meet the goals of this chapter, you should be able to disassemble the Instrument down to replacement part level.

The main replaceable assemblies for the Monitor are as follows:

- The Power Supply.
- The System Board.
- The Connector Board.
- The LCD Assembly.
- The Display Backlight Tubes.

The removal and replacement procedures for the Monitor are easy to complete when you follow the step-by-step procedures in this chapter.

The main replaceable assemblies for the M3015A Measurement Server Extension (*units with serial number prefix DE020xxxx only*) are as follows:

- The CO₂ Scrubber.
- The Pump.

The removal and replacement procedures for the M3015A Measurement Server Extension are easy to complete when you follow the step-by-step procedures in this chapter.

The main replaceable parts of the M8043A Battery Charger and Conditioner are:

- The Air Filters (left-hand and right-hand)
- The Cooling Fans (left-hand and right-hand)

Follow the step-by-step removal and replacement procedures starting on page 239.

The M3000A and M3001A Measurement Servers and the extensions M3016A and M3015A (serial number prefix DE435xxxx only) cannot be repaired and must be exchanged if defective.

Concepts

Before starting disassembly of the Monitor, remove the rubber bezel protector, if fitted.

Disassembly Disassembly refers to the removal of cover, chassis and other parts in order to access and replace parts in the M3046A Monitor and the M3015A Measurement Server Extension. Disassembly does not refer to a complete

breakdown of the entire Instrument since the Measurement Server and the M3016A Measurement Server Extension cannot be disassembled.

High Voltage This concept refers to voltages dangerous to life. High voltages can be found in the Instrument when it is connected to the mains Power Supply and in the capacitors on the Power Supply board even when the Instrument is not connected to the mains Power Supply.

Warnings, Cautions and Safety Precautions

- Do **NOT** disassemble the product past the point described in these procedures.
- **High Voltage Warning**—Voltages dangerous to life are present in the Instrument when it is connected to the mains Power Supply. Do not perform any disassembly procedures other than Server and Extension removal with power applied to the Instrument. Failure to adhere to this warning could cause serious injury or death.
- **Residual High Voltage**—There may be hazardous voltages stored in capacitors on the Power Supply board even when the Instrument is not connected to the mains Power Supply. High voltages are present on the Power Supply board for up to 20 seconds after disconnecting the mains power cord so always disconnect the Power Supply cord and wait at least 20 seconds before removing or refitting the Power Supply board.
- **Battery Warning**—Never insert a battery without the Power Supply board being present. You may blow the battery fuse on the Connector Board.
- **Power Cord Warning**—Do not connect a mains power cord to a Power Supply that has been removed from the Monitor.

General Reassembly/Refitting Comments

- **Battery Door**—When inserting the Monitor chassis, always open the battery compartment door to avoid striking the door clip.
- **Ribbon Connections**—Make sure male-female ribbon connections are correctly lined up.
- **Open Component**—Do not allow anything to fall into the open component.

Disassembly for the Monitor

Removing the Battery

To remove the battery, do the following:

- Step 1** Slide the battery compartment door toward the rear of the Monitor, and open it down.
- Step 2** Locate the battery extractor tape and pull it to disengage the battery socket.
- Step 3** Pull the battery out.

Removing the Power Supply

Read the warnings at the beginning of this chapter.

You must remove the Power Supply to access the fuse.

To remove the Power Supply, do the following:

- Step 1** Remove the Measurement Server and, where present, the Measurement Server Extension.
- Step 2** Remove the battery.
- Step 3** Switch on the Instrument and disconnect the AC power cord from both the Instrument and the mains power source (after 20 seconds, the capacitors on the Power Supply board are drained).
- Step 4** Push a thin-bladed screwdriver into the hole next to the cover:

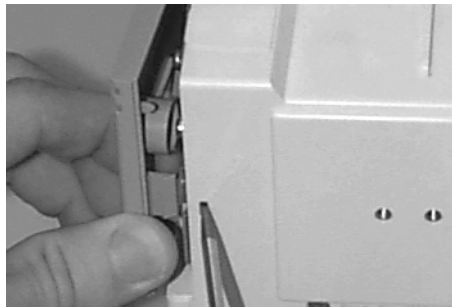

- Step 5** Release the cover.
- Step 6** Remove the two anti-vibration screws. (These are the only anti-vibration screws and must be refitted. Do not lose these screws.)

Step 7 Slide out the Power Supply:

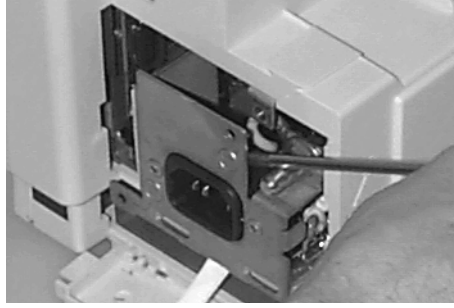

Removing the Chassis

Read the warnings at the beginning of this chapter.

To remove the chassis, do the following:

Step 1 Remove the Server.

Step 2 Remove the battery.

Step 3 Switch the Instrument on and disconnect the AC power cord from the Instrument and the mains power source (after 20 seconds, the capacitors on the Power Supply board are drained).

Step 4 Push a thin-bladed screwdriver into the hole next to the cover:

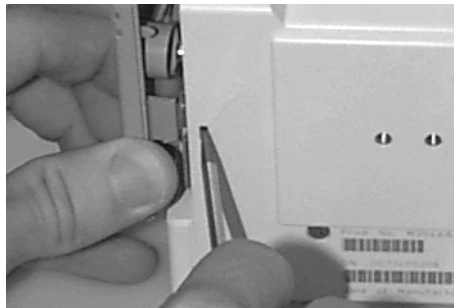

Step 5 Release the cover.

Step 6 Prise open the clip on the Server-to-Monitor link bar and slide it off. On newer monitors just turn the catch (holding the link bar) into the vertical position:

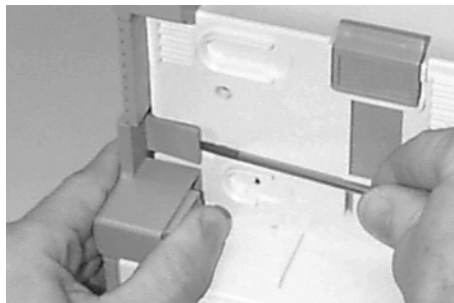

Step 7 Lay the Monitor on its rear panel and pull out the two latches - there is one on each side of the Monitor Bezel:

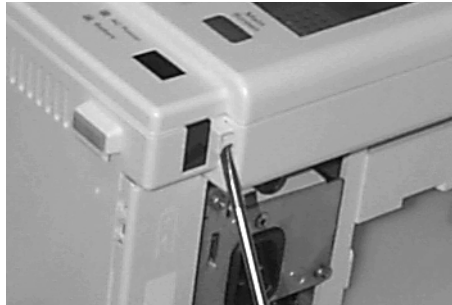

Step 8 Stand the Monitor up again and gently lift the Monitor Bezel up and out. Gently let it rest in front of the Monitor. Be careful. It still has a cable attached:

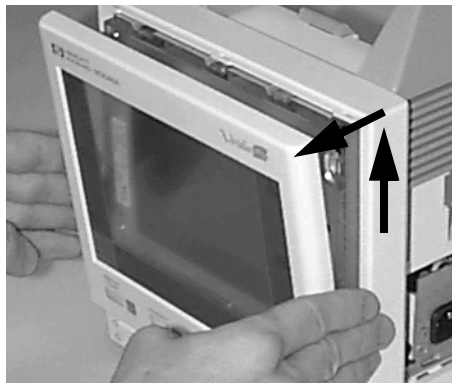

Step 9 Remove the white plastic clamp securing the ribbon cable connections. To remove, push the latch at the top left corner to the left.

NOTE

Step 10 Use a small screwdriver to remove the Monitor Bezel assembly cable:
Do not touch the LCD display

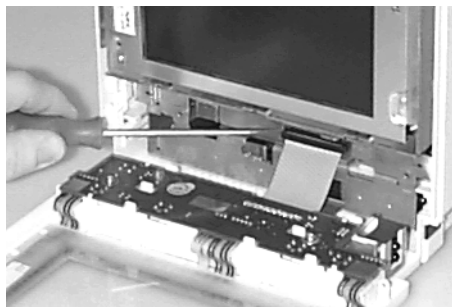

Step 11 Remove the four screws from the rear panel:

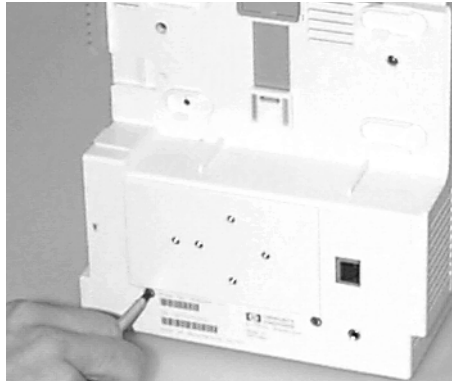

Step 12 Slide the chassis slowly out from the front of the housing (the battery compartment cover must be open), and lay the chassis on the Monitor Bezel

For Monitors with a Wireless LAN Assembly: To avoid antenna damage, slide the chassis very carefully out from the front of the housing, **disconnect the antenna cable** and lay the chassis on the Monitor Bezel:

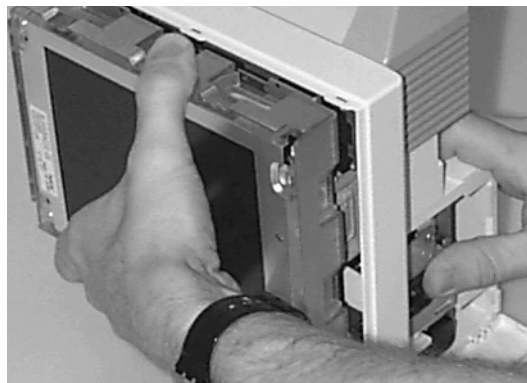

1

Removing the System Board

To remove the System Board, do the following:

Step 1 Remove the Power Supply as described previously in this chapter.

Step 2 Remove the chassis as described previously in this chapter.

Step 3 Remove the screw which secures the connector board, then pull out the Connector Board:

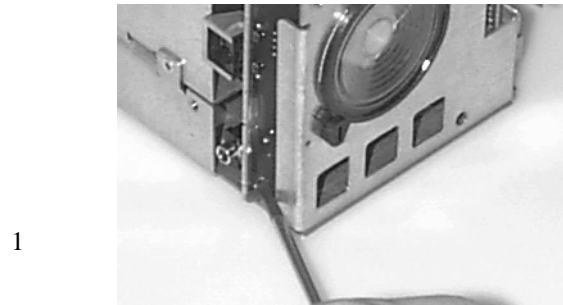

Step 4 Use a small screwdriver to disconnect the Display Assembly cable:



Step 5 Lay the chassis face down on a clean, scratch-free surface.

Step 6 Disconnect the loudspeaker cable (1).
For Monitors with Wireless LAN assembly: Disconnect the ventilator wires (2) from the system board. Unclip the fan assembly from the metal sheet (3) and pull forwards to remove:

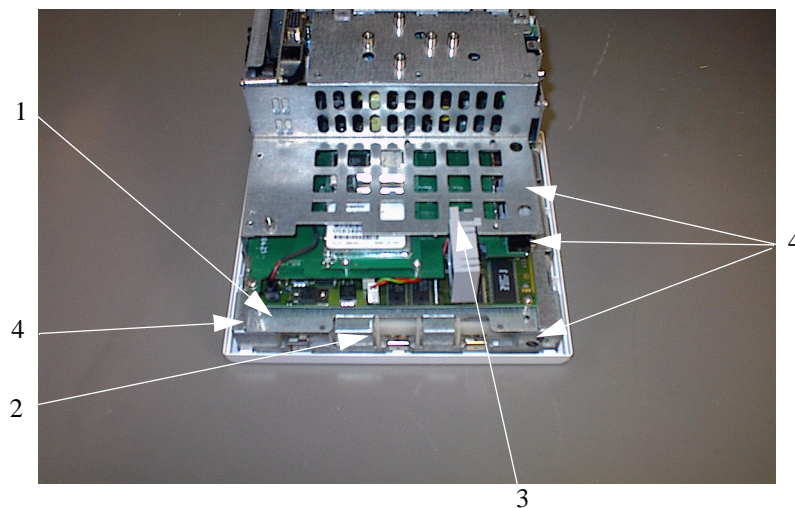

Step 7 Remove the 4 System Board screws (4).

- Step 8** Withdraw the board from the chassis towards and slightly to the right of you to avoid hitting the chassis:

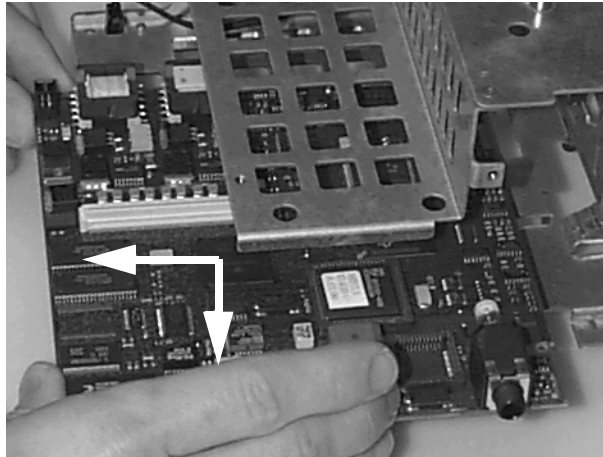

Removing the Wireless Assembly (for Monitors with Wireless LAN Interface only)

- Step 1** Remove the Server as described previously in this chapter.
- Step 2** Remove the battery as described previously in this chapter.
- Step 3** Remove the chassis as described previously in this chapter.
- Step 4** Remove the system board, complete with the wireless LAN assembly, as described previously in this chapter.
- Step 5** Lift the wireless assembly up to release the connector, then remove the assembly from the system board.

Removing the LCD Assembly and Backlight Tubes

This procedure describes how to remove the LCD Assembly which includes the LCD screen and rubber anti-vibration cushion. Once the assembly has been removed, the backlight tubes can be removed and replaced.

Although you need to remove the chassis, you do not need to remove the System Board or the Power Supply.

To remove the LCD Assembly, do the following:

- Step 1** Remove the chassis as described previously in this chapter.
- Step 2** Use a small screwdriver to remove the Display Assembly cable.
- Step 3** Push the complete assembly (including the rubber cushion, the LCD display, and the cables) out from the rear of the chassis. Start pushing from the top being careful not to damage or bend the 6 clips around the cushion:

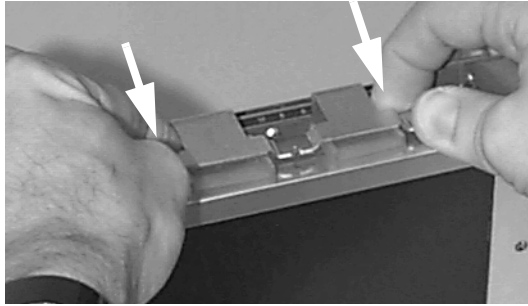

Never touch the front of the display assembly (the screen), or the backlight tubes, with your fingers. Doing so can reduce the lifetime of the parts.

Step 4 Then push from the sides:

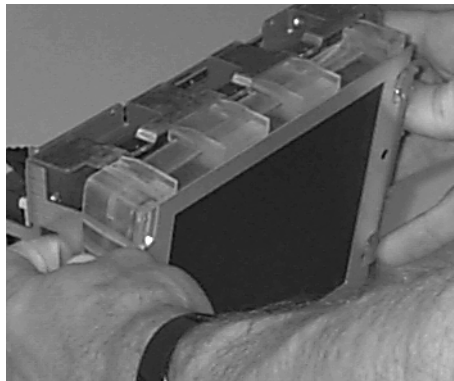

Step 5 Lay the LCD display on a flat, scratch-free surface:

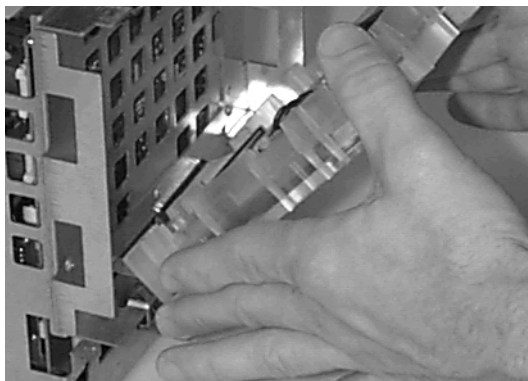

Step 6 Unplug the backlight tube cables.

Step 7 Press down the retaining lever to release the backlight tube:

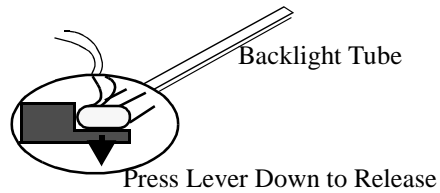
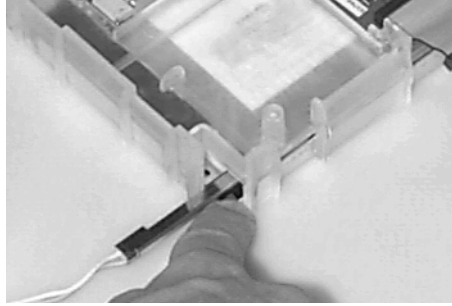

Step 8 Slide out the tube and repeat for the second tube.

Removing the Connector Board

To remove the Connector Board, do the following:

Step 1 Remove the chassis as described previously in this chapter.

Step 2 Remove the Power Supply as described previously in this chapter.

Step 3 The Connector Board (VGA) is fixed with a screw and can no longer be taken out by removing the Connector Board cover and pulling the Connector Board out. The Plastic Housing must be completely removed to allow the Connector Board to be unscrewed from the side of the Monitor:

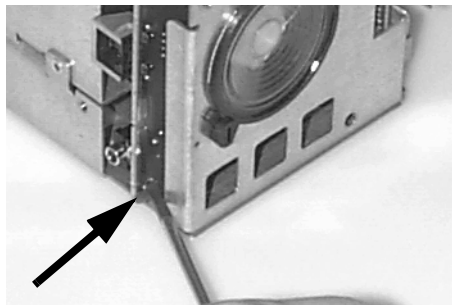

Removing the Speaker

To remove the speaker, do the following:

Step 1 Remove the chassis as described previously in this chapter.

Step 2 Remove the Power Supply.

Step 3 Remove the Connector Board.

Step 4 Disconnect the speaker cable running to the System Board.

Step 5 Rotate the two plastic holders retaining the speaker.

Step 6 Remove the speaker.

Refit Procedures for the Monitor

Refitting the System Board

To refit the System Board, complete the steps for removing the System Board in reverse.

When refitting the System Board please observe the following:

- Be careful not to strike the metal chassis with parts.
- Make sure the speaker cable is not trapped when the System Board is inserted.
- Wait until the System Board is in place before positioning the screws, otherwise they may fall out when you do the next step.
- Slightly raise the end of the System Board and push down and forward to engage the retaining clips on the chassis.
- Make sure the bottom edge of the System Board sits correctly in the clips to give a good electrical contact:

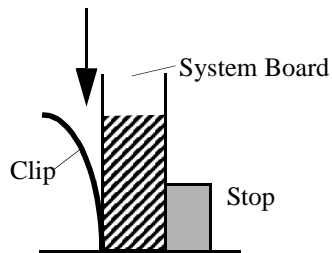

Refitting the LCD Assembly and Backlight Tubes

To refit the LCD Assembly and backlight tubes, complete the steps for removing the LCD Assembly and backlight tubes in reverse.

NOTE

When you push the Display Assembly back into the chassis, make sure that the 6 clips around the cushion are still in place and are not bent.

Refitting the Connector Board

To refit the Connector Board, complete the steps for removing the Connector Board in reverse.

Refitting the Speaker

To refit the Speaker, complete the steps for removing the Speaker in reverse.

Refitting the Power Supply

To refit the Power Supply, complete the steps for removing the Power Supply in reverse.

NOTE

When replacing the Power Supply, make sure it slides into the guide rails provided in the chassis. Be sure to refit the anti-vibration screws.

Refitting the Wireless Assembly

To refit the wireless assembly, complete the steps for removing the wireless assembly in reverse.

Refitting the Chassis

To refit the chassis, complete the steps for removing the chassis in reverse. When reconnecting the Antenna Cable, observe the following:

- Route the free end of the antenna cable through the middle hole (1, below) in the right-hand column of three holes, as viewed from the back side of the sheet metal:

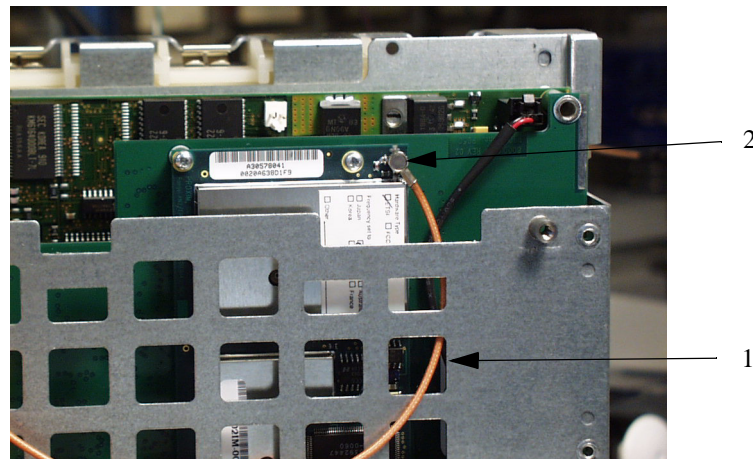

- Connect the free end of the antenna cable to the connector on the corner of the wireless LAN board (2, above).

Refitting the Battery

To refit the battery, do the following:

- Step 1** Slide the battery compartment door toward the rear of the Monitor, and open it down.
- Step 2** While holding the battery extractor tape up and out of the way, insert the battery with the battery guide-groove facing up and the battery socket towards the inside of the Monitor.
- Step 3** Push the battery all the way into the compartment making sure the socket is firmly engaged (the battery can be pushed no further).
- Step 4** Close the battery compartment door.

Disassembly Procedures for the M3015A Measurement Server Extension

Only units with serial number prefix DE020xxxxx can be repaired. For later units with serial number prefix DE435xxxxx, only the front bezel can be replaced, and the repair strategy for a defective device is unit exchange.

It is recommended that you replace all the replaceable parts in the Extension (CO₂ Scrubber and Pump) after 15 000 hours (approximately 3 years) of continuous use. See Chapter 3 Maintaining the Instrument for more details on caring for the Extension.

Tools Required:

- A thin-bladed screwdriver.
- A pair of large tweezers.
- In addition, for removing the Pump, you will need a large-bladed screwdriver.

WARNING

There is high voltage inside the Instrument (800V). Do not connect the Measurement Server Extension to a Monitor while the Extension housing is open.

As well, parts inside the Instrument may be contaminated with bacteria. Protect yourself from possible infection by wearing examination gloves during these procedures.

Removing the Front Cover

To remove the front cover, do the following:

Step 1 Remove the Server and the Monitor from the Extension.

Step 2 Use a thin-bladed screwdriver to prise the grey front cover (the console covering the measurement connector hardware) gently from the bottom of the Extension. Position the screwdriver in the small slits provided for this purpose. The front cover then clicks away from the Extension.

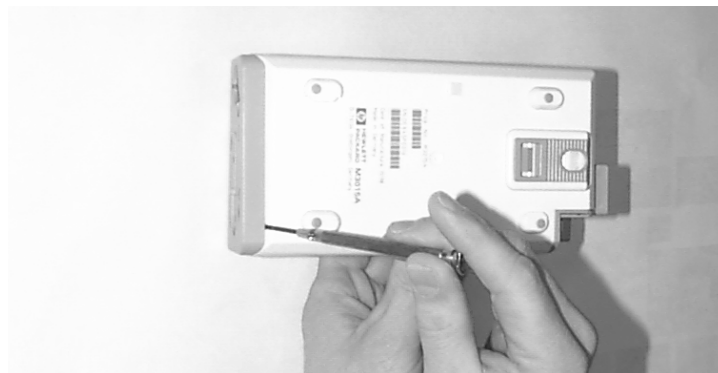

Step 3 Remove the front cover.

Removing the Extension Bottom Cover

To remove the Extension bottom cover, do the following:

- Step 1** Position the Extension on the dual link bar with the measurement connector hardware facing upwards and the arm of the dual link bar towards you. There are four long mounting pins threaded into the Extension in each of the four corners under the cover. Locate the heads of the two long mounting pins on the side away from you.

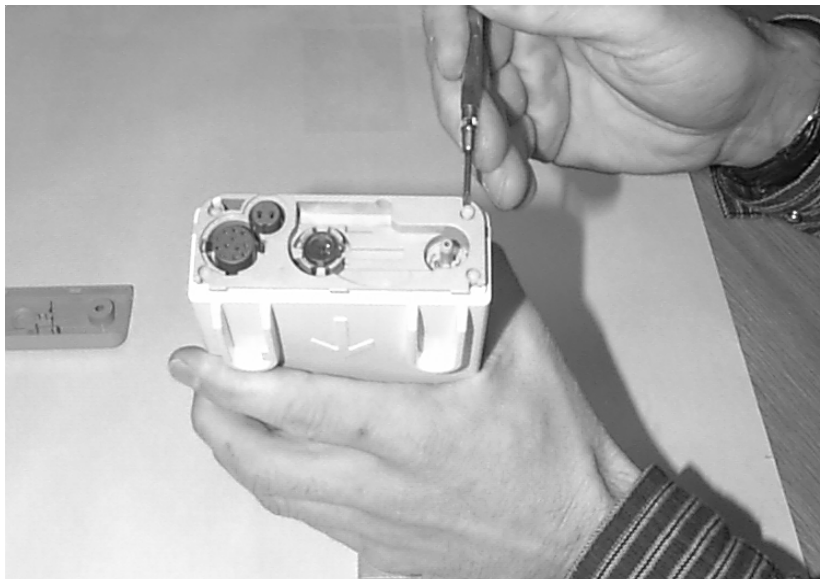

- Step 2** Use tweezers to prise the pins gently out enough to be removed by hand.

- Step 3** Remove the two pins and set them aside for refitting.

NOTE

Do not lose these long mounting pins since the Extension will not function unless they are in place.

- Step 4** Using your hands, gently pry the bottom cover away from the Extension at the link bar end first. The bottom cover is press-latched at the link bar end. Remove it gently making sure not to bang or touch the inside of the Extension.

NOTE

If you accidentally try to remove the wrong side of the bottom cover, you will notice that it is attached to the inside of the Extension with a ribbon connector and that the dual link bar prevents you from removing it completely. **Do not try to forcibly remove the wrong side of the M3015A cover; you cannot access replaceable parts from this side.**

Disassembly Procedures for the M3015A Measurement Server Extension

The following illustration shows the location of the replaceable parts in the M3015A Measurement Server Extension.

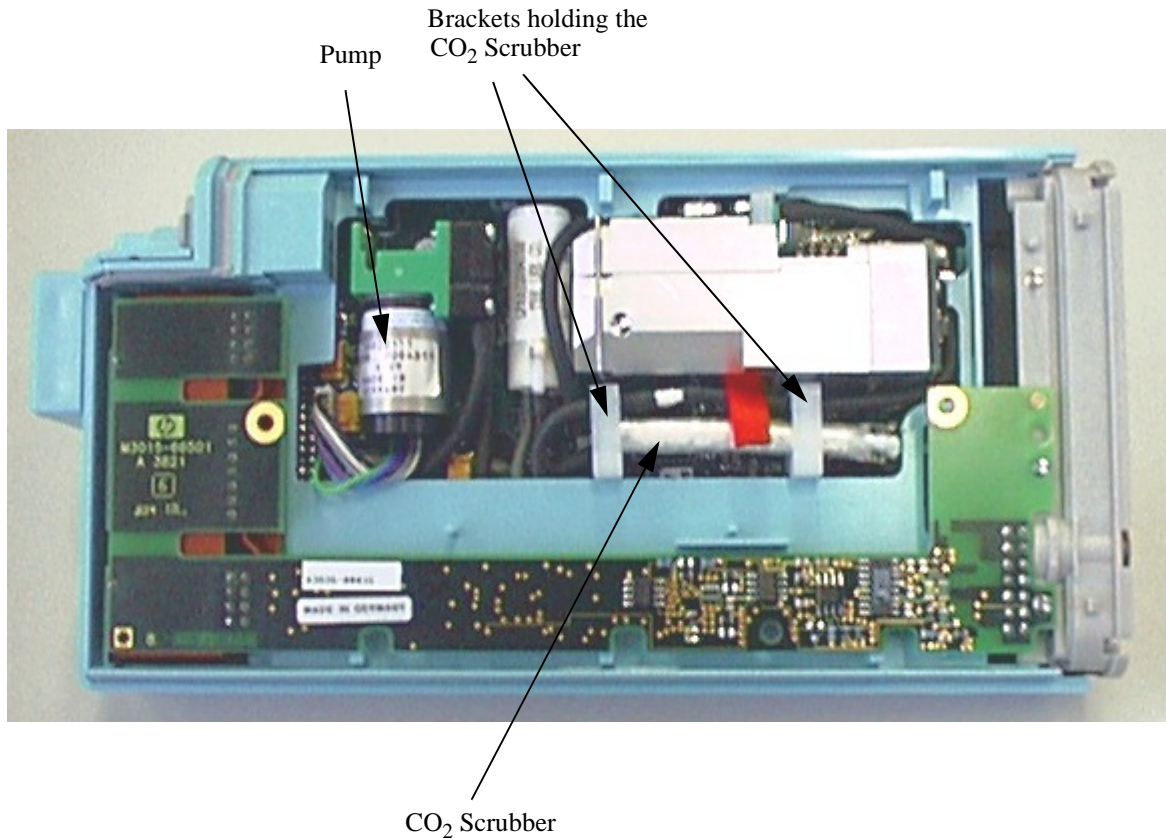

Removing the CO₂ Scrubber

To remove the CO₂ Scrubber, do the following:

- Step 1** Locate the CO₂ Scrubber in the Extension.
- Step 2** Being careful not to touch anything else in the Extension, use tweezers to pull the body of the CO₂ Scrubber out of the bracket

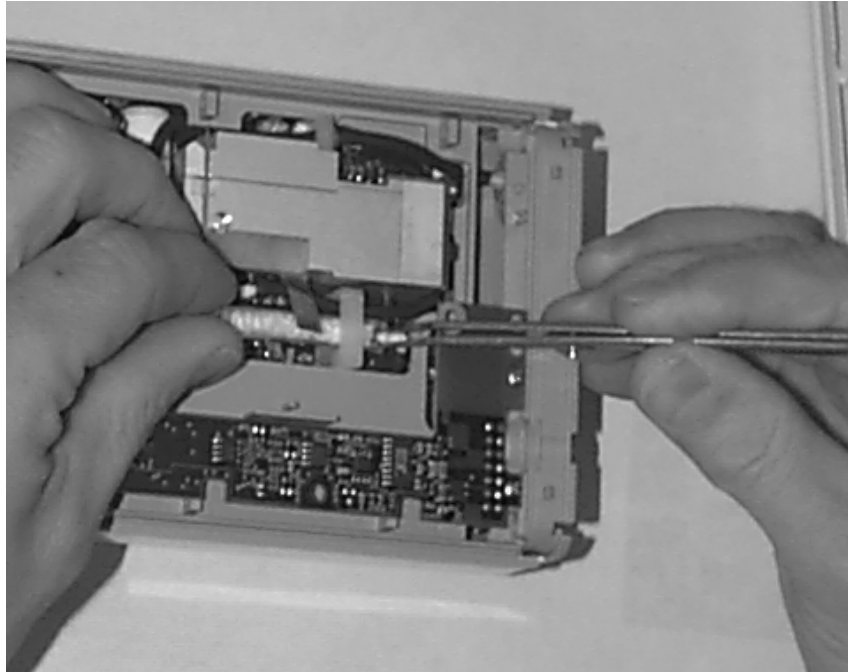

- Step 3** Holding the body of the CO₂ Scrubber with your fingers, carefully disconnect the Extension intake tube from the scrubber end and remove the CO₂ Scrubber from the Extension.
- Step 4** Dispose of the CO₂ Scrubber according to local legal requirements for low volume chemical waste.

Removing the Pump

To remove the Pump, do the following:

Step 1 Locate the Pump in the Extension.

Step 2 Being careful not to touch anything else in the Extension, unscrew the screw holding the pump bracket in position. Lift the top part of the bracket away and lift out the pump.

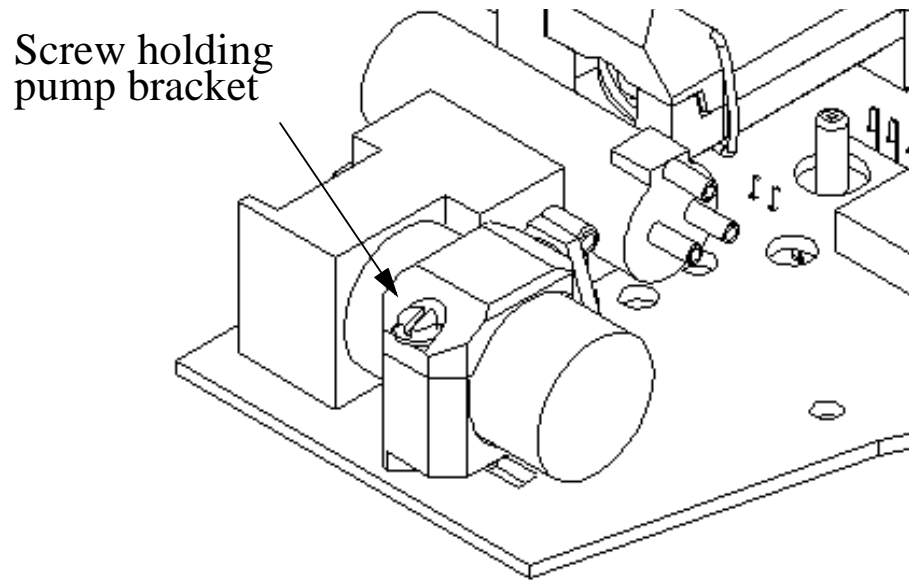

Step 3 Gently disconnect the flow tubing attached to the Extension from the Pump.

NOTE

Be sure to note which tube attaches to the inlet and which tube attaches to the outlet.

Step 4 Gently disconnect the power lead which attaches the Pump to the Extension.

Step 5 Remove the Pump.

NOTE

After replacing the Pump, reset the value displayed on the Reset PumpOpTime selection to zero (Service Mode>CO₂ Setup). When the PumpOpTime has been reset an INOP will be generated: "CO₂ OCCLUSION". To clear this INOP you must perform a flow check and store the flow in Service Mode (select "Store Flow")

Refit Procedures for the M3015A Measurement Server Extension

Tools Required:

- A thin-bladed screwdriver.
- A pair of large tweezers.
- In addition, for refitting the Pump, you will need a large-bladed screwdriver.

WARNING

There is high voltage inside the Instrument (800V). Do not connect the Measurement Server Extension to a Monitor while the Extension housing is open.

As well, parts inside the Instrument may be contaminated with bacteria. Protect yourself from possible infection by wearing examination gloves during these procedures.

Refitting the CO₂ Scrubber

WARNING

The CO₂ Scrubber contains lithium hydroxide monohydrate. This is a strong base. Do not open or damage the CO₂ Scrubber. If you come into contact with the CO₂ Scrubber material, flush the area immediately with water and consult a doctor.

To refit the CO₂ Scrubber, do the following:

- Step 1** Feed the end of the CO₂ Scrubber through the bracket to meet the Extension intake tube.
- Step 2** Push the intake tube firmly into the scrubber end to connect it.
- Step 3** Holding the body of the CO₂ Scrubber with tweezers, feed the CO₂ Scrubber fresh air intake under the second bracket and position it.

Refitting the Pump

To refit the Pump, do the following:

Step 1 Gently connect the power lead to the Extension.

NOTE

The power lead can only be connected one way. Do not try to force the power lead into position. Instead, align it correctly and connect it gently.

Step 2 Connect the flow tubing to the Pump.

NOTE

Be sure to reconnect the inlet tube to the inlet valve and the outlet tube to the outlet valve.

Step 3 Being careful not to touch anything else in the Extension, insert the pump into the bracket on the PC board. Make sure that the pump is horizontal and does not touch the PC board. (Vibration from the pump in operation will damage the Extension if the pump touches the PC board.)

Step 4 Replace the top part of the bracket and screw firmly into position.

NOTE

After replacing the Pump, reset the value displayed on the Reset PumpOpTime selection to zero (Service Mode>CO₂ Setup). When the PumpOpTime has been reset an INOP will be generated: "CO₂ OCCLUSION". To clear this INOP you must perform a flow check and store the flow in Service Mode (select "Store Flow").

Refitting the Extension Bottom Cover

To refit the Extension bottom cover, do the following:

Step 1 Latch the link bar end into place then press-click the bottom cover back into place covering the interior of the Extension.

Step 2 Holding the bottom cover firmly in place, thread the two long mounting pins back into the Extension making sure to thread them all the way to the end.

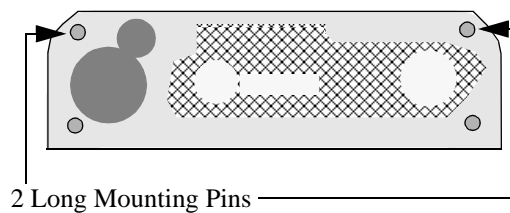

Refitting the Front Cover

To refit the front cover, press-click it back into place over the measurement connector hardware.

Disassembly Procedures for the M8043A Battery Charger and Conditioner

Opening the Housing

- Step 1** Disconnect the Battery Charger and Conditioner from AC mains power. Remove any batteries from the charger.
- Step 2** Place the device upside down and remove the five cross-head screws holding the chassis baseplate.

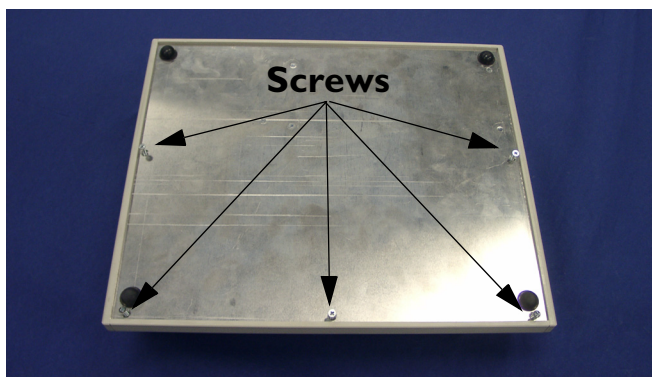

- Step 3** Lift the front edge of the chassis baseplate, then carefully pull it forwards slightly. Note that some connected cables prevent you from completely removing the baseplate.

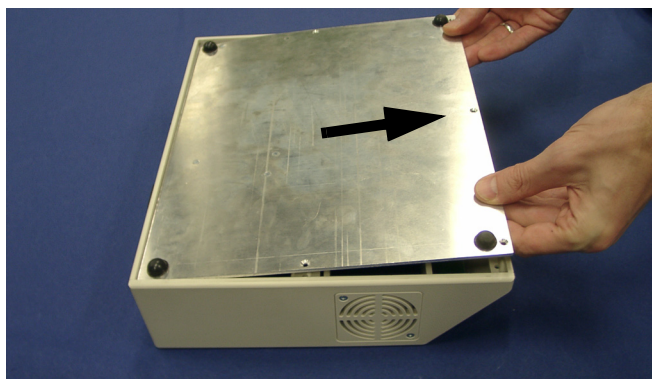

Removing the Cooling Fans

Step 1 Open the housing (see “Opening the Housing” on page 239).

Step 2 Carefully manoeuvre the baseplate to gain internal access to the left-hand cooling fan.

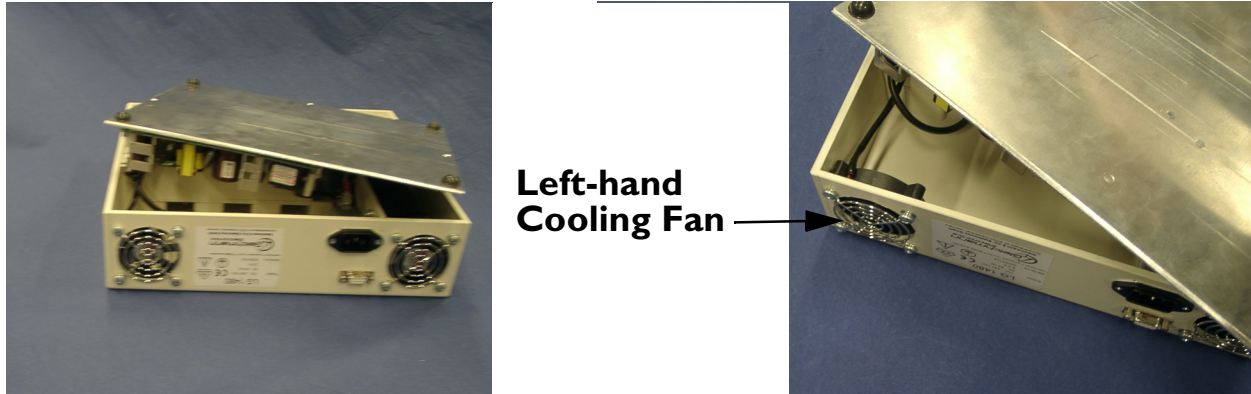

Step 3 Remove the four screws holding the cooling fan and grill.

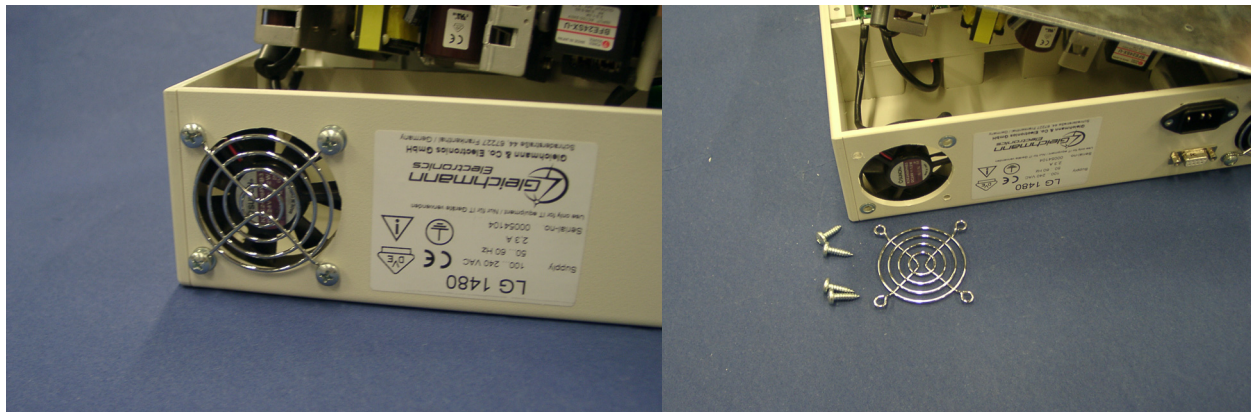

Step 4 Disconnect the two-pin plug (A) connecting the cooling fan cable to the printed circuit board. Free the cable from the cable guide (B).

Step 5 Remove the left-hand cooling fan.

Note: When reconnecting the two-pin plug, ensure that the red wire faces the left side of the housing.

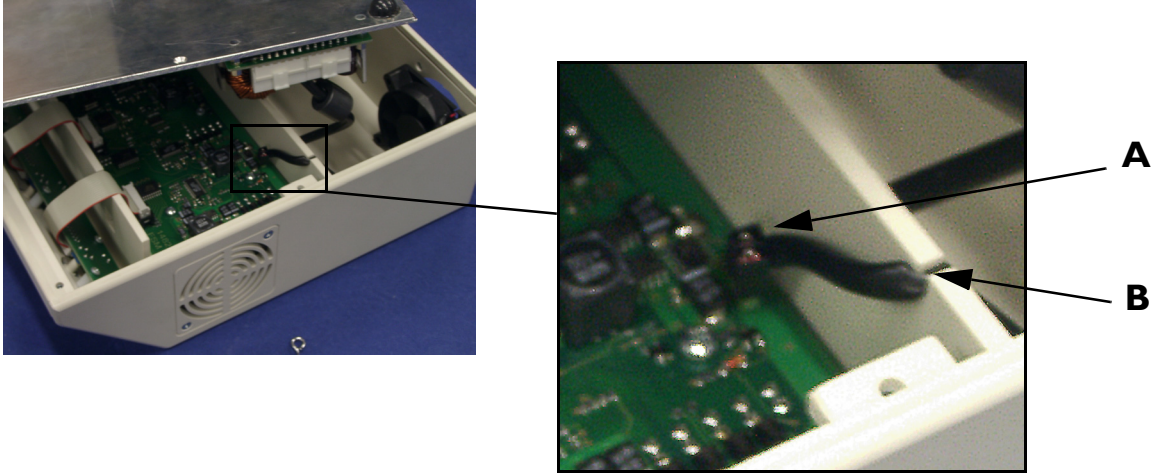

Step 6 Remove the four screws holding the right-hand cooling fan and grill.

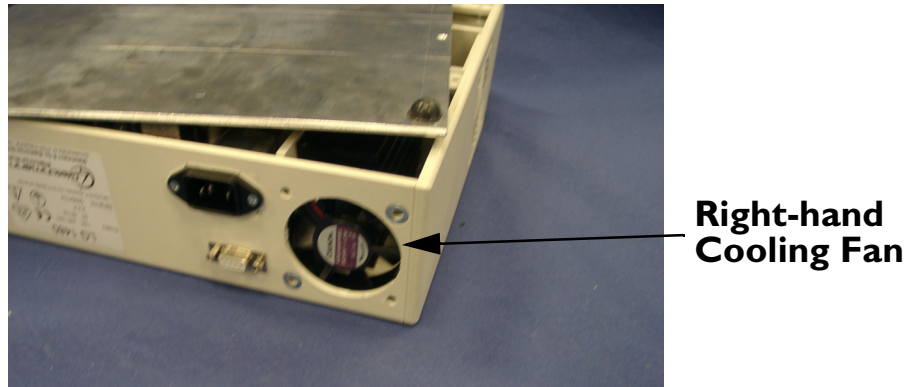

Step 7 Disconnect the two-pin plug (D) connecting the cooling fan cable to the printed circuit board. Free the cable from the cable guide (C).

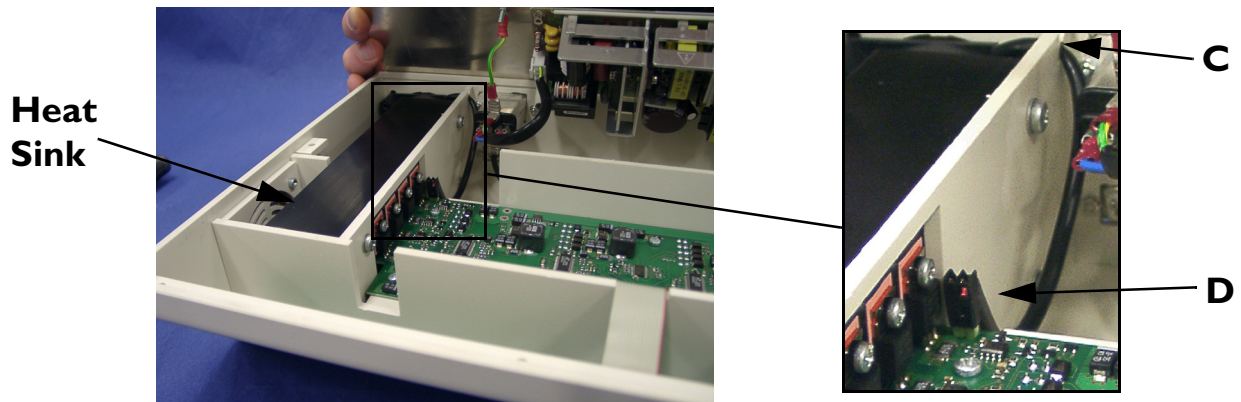

Step 8 Remove the right-hand cooling fan.

Note: When reconnecting the two-pin plug, ensure that the red wire faces the heat sink.

Removing the Air Filters

The air filters are located on the left and right side of the device.

Step 1 Open the housing (see "Opening the Housing" on page 239).

Step 2 Remove the plug from the five-pin connector on the circuit board. This allows better access to the inside of the charger.

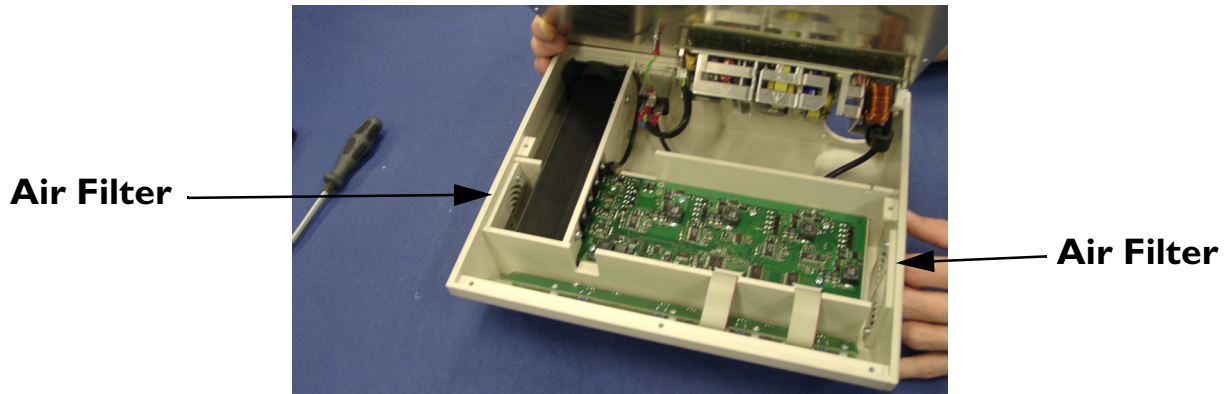

Step 3 Remove the two screws holding the air filter.

Step 4 Remove the air filter cover.

Step 5 Remove the filter mat and clean the dust out, or exchange the filter mat if required.

Step 6 Insert the mat and re-fit the cover and screws.

Reassembling the Battery Charger and Conditioner

Reassembly is the reverse of the disassembly procedure.

Following Reassembly

Once you have reassembled the Instrument, you must perform a safety and performance check on the Instrument. Refer to "Maintaining the Instrument" and "Testing the Instrument".

Tutorial for Repairing the Instrument

Question 1: What must be kept open when inserting the Monitor chassis?

- a. When inserting the chassis, the Monitor Bezel and the link bar must *not* be kept open.
- b. When inserting the chassis, the LCD assembly must be open and the backlight tubes must be exposed.
- c. When inserting the chassis, always open the battery compartment door to avoid striking the door clip.

Question 2: Which of the following are correct statements according to the warnings, cautions and safety procedures in this chapter?

- a. Do not perform any disassembly procedures other than Server and Extension removal with power applied to the Instrument.
- b. High voltages are present on the Power Supply board for up to 20 seconds after disconnecting the mains power cord.
- c. Never insert a battery without the Power Supply board being present.
- d. All of the above are correct according to this. chapter.

Question 3: What must be removed to access the fuse?

- a. When accessing the fuse, all Instrument assemblies must be removed.
- b. When accessing the fuse, the Server, the Extension, the battery, and the Power Supply must be removed.
- c. When accessing the fuse, the battery compartment cover and the battery must be removed.

Answers to Tutorial for Repairing the Instrument

- 1) c. (See pages 222, 231 and 245 for more details.)
- 2) d. (See pages 219 and 220 for more details.)
- 3) b. (See page 221 for more details.)

7 Replacement Parts

Objectives

After reading this chapter, you will be able to identify the replaceable components and know which subassemblies you can order for the Instrument.

The Instrument is comprised of several components which may be replaced or exchanged if they break. This chapter provides you with exploded views and part numbers for all field-replaceable components.

The Measurement Server, the M3016A Measurement Server Extension and later versions (Revision B) of the M3015A Measurement Server Extension (with serial number prefix DE020xxxxx) do not contain any serviceable parts. If defective, these pieces must be returned to the factory.

Compatibility Matrix - Release A to Release B

New hardware starts with serial date code **DE850XXXX** as well as with the serial date codes in the range **DE71305620** to **DE73105823**.

NEW	Main System Board M3046-66502 (exchange: M3046-68502)	Connector Board (VGA) & cover M3046-66522 M3046-44109	Monitor Power Supply M3046-60002	Metal Chassis & Plastic Housing M3046-60101 M3046-6410A	Monitor Bezel M3046-622YY
OLD					
Main System Board M3046-68XXA	n/a	yes	no	yes	yes
Connector Board (no VGA) & cover M3046-66521 M3046-44107	yes	n/a	yes	yes	yes
Monitor Power Supply M3046-60001	no	yes	n/a	yes	yes
Metal Chassis & Plastic Housing M3046-6410A	yes	yes	yes	n/a	yes
Monitor Bezel M3046-622XX	yes	yes	yes	yes	n/a

Compatibilities and Incompatibilities

Old Main System Board—An old version Main System Board can be used with the new Chassis and Housing, and the new Monitor Bezel. It cannot be used with the new Connector Board (VGA) and cover or the new Power Supply. This part will remain available for replacement use in existing Monitors.

New Main System Board—A new Main System Board can be used with all old parts *except* the old Power Supply. If an old Main System Board is replaced or exchanged for a new one, a new Power Supply is also required. The old Power Supply is not compatible with the new Main System Board.

Old Connector Board and Cover—An old version Connector Board and cover (no VGA) can be used with all new parts. This part will remain available for replacement use in existing Monitors.

New Connector Board and Cover—A new Connector Board (VGA) and cover can be used with the old Power Supply and the old Monitor Bezel. It cannot be used with the old Main System Board or the old Chassis and Housing. If an old version Connector Board (no VGA) and cover is replaced or exchanged for a new Connector Board (VGA) and cover, a new Main System Board and a new Chassis and Housing are also required.

NOTE

The new Connector Board (VGA) is fixed with a screw and can no longer be taken out by removing the Connector Board cover and pulling the Connector Board out. The Plastic Housing must be completely removed (see "Repairing the Instrument") to allow the Connector Board to be unscrewed from the side of the Monitor.

Old Power Supply—An old version Power Supply can be used with all new parts *except* the new Main System Board. If an old Power Supply is replaced or exchanged, it must be replaced with the old version Power Supply which is still available. A new Power Supply cannot be used with an old Main Board. This part will remain available for replacement use in existing Monitors.

New Power Supply—A new Power Supply can be used with all new parts *except* the old Main System Board. If an old Power Supply is replaced or exchanged for a new Power Supply, the new Main System Board is also required. A new Power Supply cannot be used with an old Main Board.

Old Chassis and Housing—An old version Chassis and Housing can be used with all new parts *except* the new Connector Board (VGA) and cover.

New Chassis and Housing—A new Chassis and Housing can be used with all new parts

Old Monitor Bezel—An old version Monitor Bezel can be used with all new parts.

New Monitor Bezel—A new Monitor Bezel can be used with all old parts.

List of Replacement and Exchange Parts

The Part Numbers in the list of parts, below, are used to order parts from your Philips representative. The Item numbers, where applicable, correspond to the illustration which follows.

Exchange parts are parts that have been returned to Philips and reconditioned for further use. Parts offered as exchange parts are in excellent service order according to rigorous Philips standards but offer a considerable price advantage to the user.

Monitor Parts

Bezel Parts

Part Number	12-Digit Reordering Number	Description	Item
IrDA Interface			
M3046-62231	453563332911	Monitor Bezel, IrDA Interface, English	1
M3046-62232	453563332921	Monitor Bezel, IrDA Interface, French	1
M3046-62233	453563332931	Monitor Bezel, IrDA Interface, German	1
M3046-62234	453563332941	Monitor Bezel, IrDA Interface, Dutch	1
M3046-62235	453563332951	Monitor Bezel, IrDA Interface, Spanish	1
M3046-62236	453563332961	Monitor Bezel, IrDA Interface, Italian	1
M3046-62237	453563332971	Monitor Bezel, IrDA Interface, Norwegian	1
M3046-62238	453563332981	Monitor Bezel, IrDA Interface, Swedish	1
M3046-62239	453563332991	Monitor Bezel, IrDA Interface, Finnish	1
M3046-62240	453563333001	Monitor Bezel, IrDA Interface, Japanese	1
M3046-62241	453563333011	Monitor Bezel, IrDA Interface, Danish	1
M3046-62242	453563333021	Monitor Bezel, IrDA Interface, Traditional Chinese	1
M3046-62243	453563333031	Monitor Bezel IrDA Interface, Simplified Chinese	1
M3046-62244	453563333041	Monitor Bezel, IrDA Interface, Portuguese	1
M3046-62245	453563333051	Monitor Bezel, IrDA Interface, Greek	1
M3046-62247	453563333061	Monitor Bezel, IrDA Interface, Russian	1
M3046-62250	453563333071	Monitor Bezel, IrDA Interface, Polish	1
Serial Interface for Local Recorder Connection			
M3046-62331	453563484941	Monitor Bezel, Serial Recorder Interface, English	
M3046-62332	453563484951	Monitor Bezel, Serial Recorder Interface, French	
M3046-62333	453563484961	Monitor Bezel, Serial Recorder Interface, German	
M3046-62334	453563484971	Monitor Bezel, Serial Recorder Interface, Dutch	
M3046-62335	453563484981	Monitor Bezel, Serial Recorder Interface, Spanish	
M3046-62336	453563484991	Monitor Bezel, Serial Recorder Interface, Italian	
M3046-62337	453563485001	Monitor Bezel, Serial Recorder Interface, Norwegian	

Part Number	12-Digit Reordering Number	Description	Item
M3046-62338	453563485011	Monitor Bezel, Serial Recorder Interface, Swedish	
M3046-62339	453563485021	Monitor Bezel, Serial Recorder Interface, Finnish	
M3046-62340	453563485031	Monitor Bezel, Serial Recorder Interface, Japanese	
M3046-62341	453563485041	Monitor Bezel, Serial Recorder Interface, Danish	
M3046-62342	453563485051	Monitor Bezel, Serial Recorder Interface, Traditional Chinese	
M3046-62343	453563485061	Monitor Bezel, Serial Recorder Interface, Simplified Chinese	
M3046-62344	453563485071	Monitor Bezel, Serial Recorder Interface, Portuguese	
M3046-62345	453563485081	Monitor Bezel, Serial Recorder Interface, Greek	
M3046-62347	453563485091	Monitor Bezel, Serial Recorder Interface, Russian	
M3046-62349	453563485101	Monitor Bezel, Serial Recorder Interface, Czech	
M3046-62350	453563485111	Monitor Bezel, Serial Recorder Interface, Polish	

Other Monitor Parts

Part Number	12-Digit Reordering Number	Description	Item
M3046-66502	453563333141	Monitor System Board, English software preloaded (Rev A) ^a	2
M3046-60001	453563332681	Monitor Power Supply assembly (old)	3
M3046-60002	453563332691	Monitor Power Supply assembly (new)	3
2110-0495 (Only type: SCHURTER SPT0001.2506)	N/A	Fuse (mounted on Power Supply Board)	
M3046-60101	453563332701	Metal Chassis assembly ^b	
M3046A #A10	N/A	Standard Plastic Housing ^b	
M3046A #A20	N/A	Wireless Plastic Housing, USA/Canada ^b	
M3046A #A21	N/A	Wireless Plastic Housing, rest of world ^b	
M3046-60202	453563332721	Display assembly	4
2090-0577	N/A	Monitor Display Backlight tube (for display ass. M3046-60201)	5
2090-0380	N/A	Monitor Display Backlight tube (for display ass. M3046-60202)	5
M3046-66521	453563333151	Connector Board (old)	7
M3046-66522	453563333161	Connector Board (VGA)	
M3046-44107	453563332631	Connector Board cover (old)	
M3046-44109	453563332641	Connector Board cover (VGA)	
M3046-64105	453563333101	Link Bar	
M3046-61601	453563332761	Flexible display cable	
M3046-44103	453563332621	Battery compartment cover	
M3046-47411	453563332651	Rubber Buttons for Monitor bezel	
M3080-61602	453563334661	External video cable, 3m	
M3080-61603	453563334671	External video cable, 10m	
M3046-55900	453563332661	Antenna for wireless	
M3046-42310	453563332591	Fan Holder for wireless	
M1022-60170	453563339161	Fan	

Part Number	12-Digit Reordering Number	Description	Item
M3046-60601	453563334651	Shield for wireless LAN operation	
M3046-61301	453563332741	Loudspeaker	
M3046-44102	453563332611	M3 cover power supply	
M3046-66502	453563333141	Monitor System Board, English software preloaded (Rev A) ^a	2
M3046-60001	453563332681	Monitor Power Supply assembly (old)	3
M3046-60002	453563332691	Monitor Power Supply assembly (new)	3
M3046-63201	453563484761	Table top mount (also adapter plate for rollstand M3080A #A10).	
M3046-44110	453563484821	Removable Frame for the serial connector	
M3046-64102	453563333091	Small Parts Kit (See separate table on page 253)	

- a. Use the M3/M4 Support Tool to configure the software for a specific release/language, if necessary.
- b. Order only through the Sales channel, stating the serial number.

Monitor Exchange Parts

Exchange Part Number	12-Digit Reordering Number	Description	Item
M3046-68502	453563333331	Exchange Monitor System Board, English software preloaded (Rel.A) ^a	2

- a. Use the M3/M4 Support Tool to configure the software for a specific release/language, if necessary.

Monitor Parts

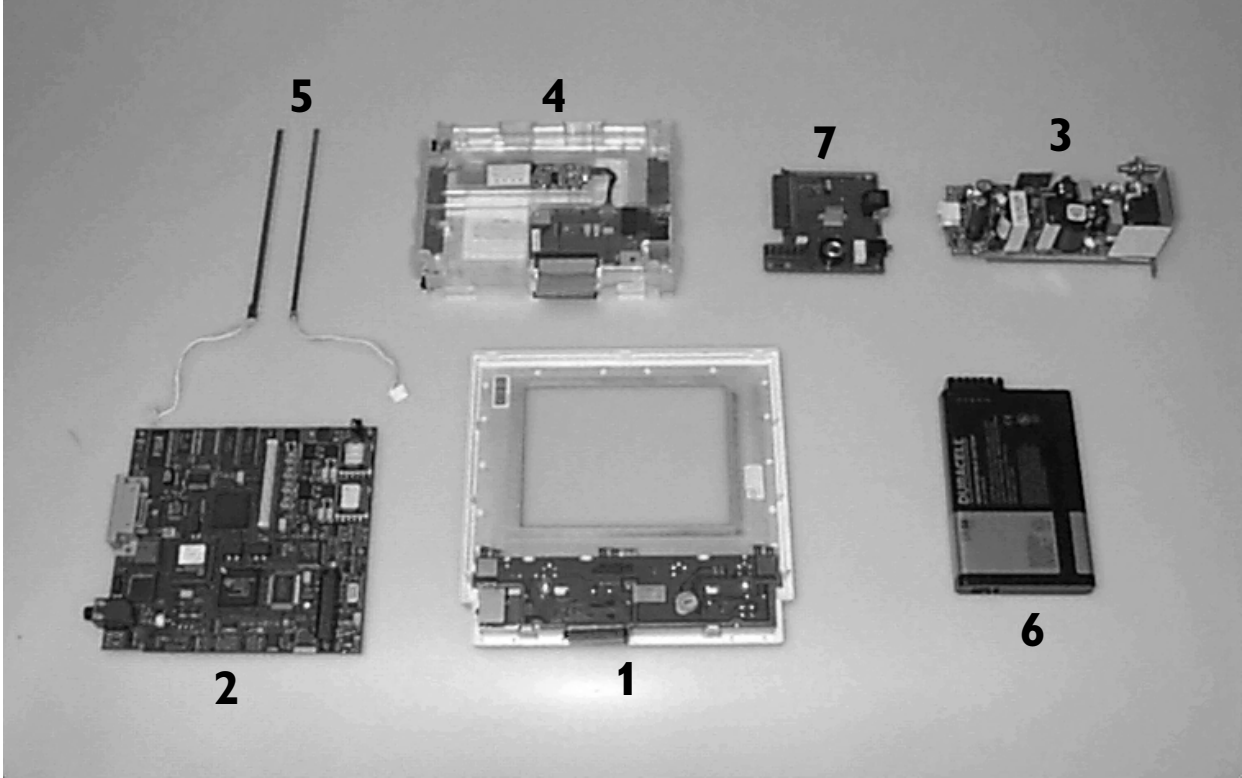

Small Parts Kit

Part Number	Description		Item
M3046-64102	Small Parts Kit - includes:		(See illustration on page 253)
	<u>Qty</u>	<u>Part number</u> <u>Description</u>	
	4	5041-5125 Foot Bumper (Fits all Measurement Servers and Server Extensions)	8
	4	M3046-41001 Foot Bumper	9
	1	5041-8116 Rubber key	10
	1	5041-8118 Hook	11
	4	RFI Metal Clip	12
	3	0515-0886 Screw	13
	2	Pins for Battery Compartment Door	14
	1	M3046-48102 IR window	15
	2	White Pull Bezel Tabs	16
	1	M3046-42305 White Plastic Cable Keeper	17
	1	M3015/16 White Tab with Spring	18
	1	M3046-44104 Grey plastic cover for upgrade port	19

Small Parts Kit M3046-64102



Multi-Measurement Server Parts

The Multi-Measurement Server (MMS) does not contain any serviceable parts and can only be replaced in its entirety.

Multi-Measurement Servers are shipped with English front bezels only. If you require a bezel in another language (compare the part numbers of your language to the English ones to check this) the front bezel has to be ordered additionally. Attach the appropriate bezel before putting the MMS into operation.

M3001A Part Numbers - Front Bezel

Language	Part Number	12-Digit Reordering Number
Standard Version and Option #C12 (Conventional 12-Lead ECG with IntelliVue only^a)		
English	M3001-64101	453563462481
French	M3001-64102	453563462491
German	M3001-64103	453563462501
Dutch	M3001-64104	453563462511
Spanish	M3001-64105	453563462521
Italian	M3001-64106	453563462381
Norwegian	M3001-64107	453563462391
Swedish	M3001-64108	453563462401
Finnish	M3001-64109	453563462411
Japanese	M3001-64101	453563462481
Danish	M3001-64111	453563462421
Traditional Chinese	M3001-64101	453563462481
Simplified Chinese	M3001-64101	453563462481
Portuguese	M3001-64114	453563462431
Greek	M3001-64115	453563462441
Turkish	M3001-64101	453563462481
Russian	M3001-64117	453563462451
Hungarian	M3001-64101	453563462481
Czech	M3001-64119	453563462461
Polish	M3001-64120	453563462471
Slovak	M3001-64101	453563462481
Korean	M3001-64101	453563462481

Language	Part Number	12-Digit Reordering Number
Option #C06 (Pressure/Temp Extension) and Option #C18 (Pressure Temp Extension, Conventional 12-Lead ECG with IntelliVue only^a)		
English	M3001-44101	453563462661
French	M3001-44102	453563462671
German	M3001-44103	453563462681
Dutch	M3001-44104	453563462531
Spanish	M3001-44105	453563462541
Italian	M3001-44106	453563462551
Norwegian	M3001-44107	453563462561
Swedish	M3001-44108	453563462571
Finnish	M3001-44109	453563462581
Japanese	M3001-44101	453563462661
Danish	M3001-44111	453563462591
Traditional Chinese	M3001-44101	453563462661
Simplified Chinese	M3001-44101	453563462661
Portuguese	M3001-44114	453563462601
Greek	M3001-44115	453563462611
Turkish	M3001-44101	453563462661
Russian	M3001-44117	453563462621
Hungarian	M3001-44101	453563462661
Czech	M3001-44119	453563462631
Polish	M3001-44120	453563462641
Slovak	M3001-44101	453563462661
Korean	M3001-44101	453563462661

- a. All versions of the M3001A Measurement Server offer EASI lead placement using an EASI 5-electrode cable set. The conventional 12-lead ECG capability of M3001A #C12 and #C18 works only with the IntelliVue family of monitors. You can connect a 10-electrode lead set (for example, if a patient is transferred from an IntelliVue-family monitor), but only the standard five electrodes (RA, LA, RL, LL, and V) are used for monitoring. The rest are automatically ignored.

M3001A MMS Part Numbers - IntelliVue Software Revision A.05.xx and Lower

Language	New Parts		Exchange Parts	
	Part Number	12-Digit Reordering Number	Exchange Part Number	12-Digit Reordering Number
Standard Version (5-Lead ECG, no Pressure/Temp)				
English	M3001-60101	453563463131	M3001-68101	453563463121
French	M3001-60501	453563460691	M3001-68501	453563460631
German	M3001-60501	453563460691	M3001-68501	453563460631
Dutch	M3001-60501	453563460691	M3001-68501	453563460631
Spanish	M3001-60501	453563460691	M3001-68501	453563460631
Italian	M3001-60501	453563460691	M3001-68501	453563460631
Norwegian	M3001-60501	453563460691	M3001-68501	453563460631
Swedish	M3001-60501	453563460691	M3001-68501	453563460631
Finnish	M3001-60501	453563460691	M3001-68501	453563460631
Japanese	M3001-60501	453563460691	M3001-68501	453563460631
Danish	M3001-60501	453563460691	M3001-68501	453563460631
Traditional Chinese	M3001-60501	453563460691	M3001-68501	453563460631
Simplified Chinese	M3001-60501	453563460691	M3001-68501	453563460631
Portuguese	M3001-60501	453563460691	M3001-68501	453563460631
Greek	M3001-60501	453563460691	M3001-68501	453563460631
Turkish	M3001-60501	453563460691	M3001-68501	453563460631
Russian	M3001-60501	453563460691	M3001-68501	453563460631
Hungarian	M3001-60501	453563460691	M3001-68501	453563460631
Czech	M3001-60501	453563460691	M3001-68501	453563460631
Polish	M3001-60501	453563460691	M3001-68501	453563460631
Slovak	M3001-60501	453563460691	M3001-68501	453563460631
Korean	M3001-60501	453563460691	M3001-68501	453563460631
Option #C06 (5-Lead ECG, Pressure/Temp Extension)				
English	M3001-60201	453563460661	M3001-68201	453563460601
French	M3001-60601	453563460701	M3001-68601	453563460641
German	M3001-60601	453563460701	M3001-68601	453563460641
Dutch	M3001-60601	453563460701	M3001-68601	453563460641
Spanish	M3001-60601	453563460701	M3001-68601	453563460641
Italian	M3001-60601	453563460701	M3001-68601	453563460641
Norwegian	M3001-60601	453563460701	M3001-68601	453563460641
Swedish	M3001-60601	453563460701	M3001-68601	453563460641
Finnish	M3001-60601	453563460701	M3001-68601	453563460641
Japanese	M3001-60601	453563460701	M3001-68601	453563460641

Language	New Parts		Exchange Parts	
	Part Number	12-Digit Reordering Number	Exchange Part Number	12-Digit Reordering Number
Danish	M3001-60601	453563460701	M3001-68601	453563460641
Traditional Chinese	M3001-60601	453563460701	M3001-68601	453563460641
Simplified Chinese	M3001-60601	453563460701	M3001-68601	453563460641
Portuguese	M3001-60601	453563460701	M3001-68601	453563460641
Greek	M3001-60601	453563460701	M3001-68601	453563460641
Turkish	M3001-60601	453563460701	M3001-68601	453563460641
Russian	M3001-60601	453563460701	M3001-68601	453563460641
Hungarian	M3001-60601	453563460701	M3001-68601	453563460641
Czech	M3001-60601	453563460701	M3001-68601	453563460641
Polish	M3001-60601	453563460701	M3001-68601	453563460641
Slovak	M3001-60601	453563460701	M3001-68601	453563460641
Korean	M3001-60601	453563460701	M3001-68601	453563460641
Option #C12 (Functionality as Standard Version with M3/M4. Conventional 12-Lead ECG with IntelliVue family only)^a				
English	M3001-60301	453563460671	M3001-68301	453563460611
French	M3001-60701	453563460711	M3001-68701	453563460651
German	M3001-60701	453563460711	M3001-68701	453563460651
Dutch	M3001-60701	453563460711	M3001-68701	453563460651
Spanish	M3001-60701	453563460711	M3001-68701	453563460651
Italian	M3001-60701	453563460711	M3001-68701	453563460651
Norwegian	M3001-60701	453563460711	M3001-68701	453563460651
Swedish	M3001-60701	453563460711	M3001-68701	453563460651
Finnish	M3001-60701	453563460711	M3001-68701	453563460651
Japanese	M3001-60701	453563460711	M3001-68701	453563460651
Danish	M3001-60701	453563460711	M3001-68701	453563460651
Traditional Chinese	M3001-60701	453563460711	M3001-68701	453563460651
Simplified Chinese	M3001-60701	453563460711	M3001-68701	453563460651
Portuguese	M3001-60701	453563460711	M3001-68701	453563460651
Greek	M3001-60701	453563460711	M3001-68701	453563460651
Turkish	M3001-60701	453563460711	M3001-68701	453563460651
Russian	M3001-60701	453563460711	M3001-68701	453563460651
Hungarian	M3001-60701	453563460711	M3001-68701	453563460651
Czech	M3001-60701	453563460711	M3001-68701	453563460651
Polish	M3001-60701	453563460711	M3001-68701	453563460651
Slovak	M3001-60701	453563460711	M3001-68701	453563460651
Korean	M3001-60701	453563460711	M3001-68701	453563460651

Language	New Parts		Exchange Parts	
	Part Number	12-Digit Reordering Number	Exchange Part Number	12-Digit Reordering Number
Option #C18 (Functionality as #C06 with M3/M4. Conventional 12-Lead ECG with IntelliVue family only)^a				
English	M3001-60401	453563460681	M3001-68401	453563460621
French	M3001-60801	453563460721	M3001-68801	453563460591
German	M3001-60801	453563460721	M3001-68801	453563460591
Dutch	M3001-60801	453563460721	M3001-68801	453563460591
Spanish	M3001-60801	453563460721	M3001-68801	453563460591
Italian	M3001-60801	453563460721	M3001-68801	453563460591
Norwegian	M3001-60801	453563460721	M3001-68801	453563460591
Swedish	M3001-60801	453563460721	M3001-68801	453563460591
Finnish	M3001-60801	453563460721	M3001-68801	453563460591
Japanese	M3001-60801	453563460721	M3001-68801	453563460591
Danish	M3001-60801	453563460721	M3001-68801	453563460591
Traditional Chinese	M3001-60801	453563460721	M3001-68801	453563460591
Simplified Chinese	M3001-60801	453563460721	M3001-68801	453563460591
Portuguese	M3001-60801	453563460721	M3001-68801	453563460591
Greek	M3001-60801	453563460721	M3001-68801	453563460591
Turkish	M3001-60801	453563460721	M3001-68801	453563460591
Russian	M3001-60801	453563460721	M3001-68801	453563460591
Hungarian	M3001-60801	453563460721	M3001-68801	453563460591
Czech	M3001-60801	453563460721	M3001-68801	453563460591
Polish	M3001-60801	453563460721	M3001-68801	453563460591
Slovak	M3001-60801	453563460721	M3001-68801	453563460591
Korean	M3001-60801	453563460721	M3001-68801	453563460591

- a. All versions of the M3001A Measurement Server offer EASI lead placement using an EASI 5-electrode cable set. The conventional 12-lead ECG capability of M3001A #C12 and #C18 only works with the IntelliVue family of monitors. You can connect a 10-electrode lead set (for example, if a patient is transferred from an IntelliVue monitor), but only the standard five electrodes (RA, LA, RL, LL, and V) are used for monitoring. The rest are automatically ignored.

M3001A MMS Part Numbers - IntelliVue Software Revision A.10.xx and Higher

Language	New Parts		Exchange Parts	
	Part Number	12-Digit Reordering Number	Exchange Part Number	12-Digit Reordering Number
Standard Version (5-Lead ECG, no Pressure/Temp)				
English	M3001-60102	453563462951	M3001-68102	453563462911
French	M3001-60502	453563487021	M3001-68502	453563486951
German	M3001-60502	453563487021	M3001-68502	453563486951
Dutch	M3001-60502	453563487021	M3001-68502	453563486951
Spanish	M3001-60502	453563487021	M3001-68502	453563486951
Italian	M3001-60502	453563487021	M3001-68502	453563486951
Norwegian	M3001-60502	453563487021	M3001-68502	453563486951
Swedish	M3001-60502	453563487021	M3001-68502	453563486951
Finnish	M3001-60502	453563487021	M3001-68502	453563486951
Japanese	M3001-60502	453563487021	M3001-68502	453563486951
Danish	M3001-60502	453563487021	M3001-68502	453563486951
Traditional Chinese	M3001-60502	453563487021	M3001-68502	453563486951
Simplified Chinese	M3001-60502	453563487021	M3001-68502	453563486951
Portuguese	M3001-60502	453563487021	M3001-68502	453563486951
Greek	M3001-60502	453563487021	M3001-68502	453563486951
Turkish	M3001-60502	453563487021	M3001-68502	453563486951
Russian	M3001-60502	453563487021	M3001-68502	453563486951
Hungarian	M3001-60502	453563487021	M3001-68502	453563486951
Czech	M3001-60502	453563487021	M3001-68502	453563486951
Polish	M3001-60502	453563487021	M3001-68502	453563486951
Slovak	M3001-60502	453563487021	M3001-68502	453563486951
Korean	M3001-60502	453563487021	M3001-68502	453563486951
Option #C06 (5-Lead ECG, Pressure/Temp Extension)				
English	M3001-60201	453563460661	M3001-68202	453563486921
French	M3001-60602	453563487031	M3001-68602	453563486961
German	M3001-60602	453563487031	M3001-68602	453563486961
Dutch	M3001-60602	453563487031	M3001-68602	453563486961
Spanish	M3001-60602	453563487031	M3001-68602	453563486961
Italian	M3001-60602	453563487031	M3001-68602	453563486961
Norwegian	M3001-60602	453563487031	M3001-68602	453563486961
Swedish	M3001-60602	453563487031	M3001-68602	453563486961
Finnish	M3001-60602	453563487031	M3001-68602	453563486961
Japanese	M3001-60602	453563487031	M3001-68602	453563486961

Language	New Parts		Exchange Parts	
	Part Number	12-Digit Reordering Number	Exchange Part Number	12-Digit Reordering Number
Danish	M3001-60602	453563487031	M3001-68602	453563486961
Traditional Chinese	M3001-60602	453563487031	M3001-68602	453563486961
Simplified Chinese	M3001-60602	453563487031	M3001-68602	453563486961
Portuguese	M3001-60602	453563487031	M3001-68602	453563486961
Greek	M3001-60602	453563487031	M3001-68602	453563486961
Turkish	M3001-60602	453563487031	M3001-68602	453563486961
Russian	M3001-60602	453563487031	M3001-68602	453563486961
Hungarian	M3001-60602	453563487031	M3001-68602	453563486961
Czech	M3001-60602	453563487031	M3001-68602	453563486961
Polish	M3001-60602	453563487031	M3001-68602	453563486961
Slovak	M3001-60602	453563487031	M3001-68602	453563486961
Korean	M3001-60602	453563487031	M3001-68602	453563486961
Option #C12 (Functionality as Standard Version with M3/M4. Conventional 12-Lead ECG with IntelliVue family only)^a				
English	M3001-60302	453563487001	M3001-68302	453563486931
French	M3001-60702	453563487041	M3001-68702	453563486971
German	M3001-60702	453563487041	M3001-68702	453563486971
Dutch	M3001-60702	453563487041	M3001-68702	453563486971
Spanish	M3001-60702	453563487041	M3001-68702	453563486971
Italian	M3001-60702	453563487041	M3001-68702	453563486971
Norwegian	M3001-60702	453563487041	M3001-68702	453563486971
Swedish	M3001-60702	453563487041	M3001-68702	453563486971
Finnish	M3001-60702	453563487041	M3001-68702	453563486971
Japanese	M3001-60702	453563487041	M3001-68702	453563486971
Danish	M3001-60702	453563487041	M3001-68702	453563486971
Traditional Chinese	M3001-60702	453563487041	M3001-68702	453563486971
Simplified Chinese	M3001-60702	453563487041	M3001-68702	453563486971
Portuguese	M3001-60702	453563487041	M3001-68702	453563486971
Greek	M3001-60702	453563487041	M3001-68702	453563486971
Turkish	M3001-60702	453563487041	M3001-68702	453563486971
Russian	M3001-60702	453563487041	M3001-68702	453563486971
Hungarian	M3001-60702	453563487041	M3001-68702	453563486971
Czech	M3001-60702	453563487041	M3001-68702	453563486971
Polish	M3001-60702	453563487041	M3001-68702	453563486971
Slovak	M3001-60702	453563487041	M3001-68702	453563486971
Korean	M3001-60702	453563487041	M3001-68702	453563486971

Language	New Parts		Exchange Parts	
	Part Number	12-Digit Reordering Number	Exchange Part Number	12-Digit Reordering Number
Option #C18 (Functionality as #C06 with M3/M4. Conventional 12-Lead ECG with IntelliVue family only)^a				
English	M3001-60402	453563487011	M3001-68402	453563486941
French	M3001-60802	453563487051	M3001-68802	453563486981
German	M3001-60802	453563487051	M3001-68802	453563486981
Dutch	M3001-60802	453563487051	M3001-68802	453563486981
Spanish	M3001-60802	453563487051	M3001-68802	453563486981
Italian	M3001-60802	453563487051	M3001-68802	453563486981
Norwegian	M3001-60802	453563487051	M3001-68802	453563486981
Swedish	M3001-60802	453563487051	M3001-68802	453563486981
Finnish	M3001-60802	453563487051	M3001-68802	453563486981
Japanese	M3001-60802	453563487051	M3001-68802	453563486981
Danish	M3001-60802	453563487051	M3001-68802	453563486981
Traditional Chinese	M3001-60802	453563487051	M3001-68802	453563486981
Simplified Chinese	M3001-60802	453563487051	M3001-68802	453563486981
Portuguese	M3001-60802	453563487051	M3001-68802	453563486981
Greek	M3001-60802	453563487051	M3001-68802	453563486981
Turkish	M3001-60802	453563487051	M3001-68802	453563486981
Russian	M3001-60802	453563487051	M3001-68802	453563486981
Hungarian	M3001-60802	453563487051	M3001-68802	453563486981
Czech	M3001-60802	453563487051	M3001-68802	453563486981
Polish	M3001-60802	453563487051	M3001-68802	453563486981
Slovak	M3001-60802	453563487051	M3001-68802	453563486981
Korean	M3001-60802	453563487051	M3001-68802	453563486981

- a. All versions of the M3001A Measurement Server offer EASI lead placement using an EASI 5-electrode cable set. The conventional 12-lead ECG capability of M3001A #C12 and #C18 only works with the IntelliVue family of monitors. You can connect a 10-electrode lead set (for example, if a patient is transferred from an IntelliVue monitor), but only the standard five electrodes (RA, LA, RL, LL, and V) are used for monitoring. The rest are automatically ignored.

M3000A Measurement Server Parts

Description	New Parts		Exchange Parts	
	Part Number	12-Digit Reordering Number	Part Number	12-Digit Reordering Number
M3000A Rel. A				
Exchange Measurement Server, English (Rel. A)	M3000-6001A	453563331761	M3000-6801A	453563331781
Exchange Measurement Server, French (Rel. A)	M3000-6002A	453563485471	M3000-6802A	453563331801
Exchange Measurement Server, German (Rel. A)	M3000-6003A	453563485481	M3000-6803A	453563331821
Exchange Measurement Server, Dutch (Rel. A)	M3000-6004A	453563485491	M3000-6804A	453563331841
Exchange Measurement Server, Spanish (Rel. A)	M3000-6005A	453563485501	M3000-6805A	453563331861
Exchange Measurement Server, Italian (Rel. A)	M3000-6006A	453563485511	M3000-6806A	453563331881
Exchange Measurement Server, Norwegian (Rel. A)	M3000-6007A	453563485521	M3000-6807A	453563331901
Exchange Measurement Server, Swedish (Rel. A)	M3000-6008A	453563485531	M3000-6808A	453563331921
Exchange Measurement Server, Finnish (Rel. A)	M3000-6009A	453563485541	M3000-6809A	453563331941
Exchange Measurement Server, Japanese (Rel. A)	N/A	N/A	M3000-6810A	453563331961
Exchange Measurement Server, Danish (Rel. A)	M3000-6011A	453563485551	M3000-6811A	453563331981
Exchange Measurement Server, Traditional Chinese (Rel. A)	M3000-6012A	453563485561	M3000-6812A	453563332001
Exchange Measurement Server, Simplified Chinese (Rel. A)	M3000-6013A	453563485571	M3000-6813A	453563332021
Exchange Measurement Server, Portuguese (Rel. A)	M3000-6014A	453563485581	M3000-6814A	453563332041
Exchange Measurement Server, Greek (Rel. A)	N/A	N/A	M3000-6815A	N/A
Exchange Measurement Server, Russian (Rel. A)	N/A	N/A	M3000-6817A	N/A
Exchange Measurement Server, Polish (Rel. A)	N/A	N/A	M3000-6820A	N/A

Description	New Parts		Exchange Parts	
	Part Number	12-Digit Reordering Number	Part Number	12-Digit Reordering Number
M3000A Rel. D with Press/Temp				
Exchange Measurement Server, ECG, NBP, SpO ₂ , Press/Temp, English (Rel. D.0)	M3000-6001B	453563485591	M3000-6801B	453563331791
Exchange Measurement Server, ECG, NBP, SpO ₂ , Press/Temp, French (Rel. D.0)	M3000-6002B	453563485601	M3000-6802B	453563331811
Exchange Measurement Server, ECG, NBP, SpO ₂ , Press/Temp, German (Rel. D.0)	M3000-6003B	453563377771	M3000-6803B	453563331831
Exchange Measurement Server, ECG, NBP, SpO ₂ , Press/Temp, Dutch (Rel. D.0)	M3000-6004B	453563485611	M3000-6804B	453563331851
Exchange Measurement Server, ECG, NBP, SpO ₂ , Press/Temp, Spanish (Rel. D.0)	M3000-6005B	453563485621	M3000-6805B	453563331871
Exchange Measurement Server, ECG, NBP, SpO ₂ , Press/Temp, Italian (Rel. D.0)	M3000-6006B	453563485631	M3000-6806B	453563331891
Exchange Measurement Server, ECG, NBP, SpO ₂ , Press/Temp, Norwegian (Rel. D.0)	M3000-6007B	453563485641	M3000-6807B	453563331911
Exchange Measurement Server, ECG, NBP, SpO ₂ , Press/Temp, Swedish (Rel. D.0)	M3000-6008B	453563485651	M3000-6808B	453563331931
Exchange Measurement Server, ECG, NBP, SpO ₂ , Press/Temp, Finnish (Rel. D.0)	M3000-6009B	453563485661	M3000-6809B	453563331951
Exchange Measurement Server, ECG, NBP, SpO ₂ , Press/Temp, Japanese (Rel. D.0)	M3000-6010B	453563377781	M3000-6810B	453563331971
Exchange Measurement Server, ECG, NBP, SpO ₂ , Press/Temp, Danish (Rel. D.0)	M3000-6011B	453563485671	M3000-6811B	453563331991
Exchange Measurement Server, ECG, NBP, SpO ₂ , Press/Temp, Traditional Chinese (Rel. D.0)	M3000-6012B	453563485681	M3000-6812B	453563332011
Exchange Measurement Server, ECG, NBP, SpO ₂ , Press/Temp, Simplified Chinese (Rel. D.0)	M3000-6013B	453563485691	M3000-6813B	453563332031

Description	New Parts		Exchange Parts	
	Part Number	12-Digit Reordering Number	Part Number	12-Digit Reordering Number
Exchange Measurement Server, ECG, NBP, SpO ₂ , Press/Temp, Portuguese (Rel. D.0)	M3000-6014B	453563485701	M3000-6814B	453563332051
Exchange Measurement Server, ECG, NBP, SpO ₂ , Press/Temp, Greek (Rel. D.0)	M3000-6015B	453563485711	M3000-6815B	453563332061
Exchange Measurement Server, ECG, NBP, SpO ₂ , Press/Temp, Russian (Rel. D.0)	M3000-6017B	453563377791	M3000-6817B	453563332071
Exchange Measurement Server, ECG, NBP, SpO ₂ , Press/Temp, Czech (Rel. D.0)	M3000-6019B	453563485721	N/A	N/A
Exchange Measurement Server, ECG, NBP, SpO ₂ , Press/Temp, Polish (Rel. D.0)	M3000-6020B	453563485731	M3000-6820B	453563332081
M3000A Rel. D without Press/Temp				
Exchange Measurement Server, ECG, NBP, SpO ₂ , English (Rel. D.0)	M3000-6031B	453563331771	M3000-6831B	453563332091
Exchange Measurement Server, ECG, NBP, SpO ₂ , French (Rel. D.0)	M3000-6032B	453563485741	M3000-6832B	453563332101
Exchange Measurement Server, ECG, NBP, SpO ₂ , German (Rel. D.0)	M3000-6033B	453563485751	M3000-6833B	453563332111
Exchange Measurement Server, ECG, NBP, SpO ₂ , Dutch (Rel. D.0)	M3000-6034B	453563485761	M3000-6834B	453563332121
Exchange Measurement Server, ECG, NBP, SpO ₂ , Spanish (Rel. D.0)	M3000-6035B	453563485771	M3000-6835B	453563332131
Exchange Measurement Server, ECG, NBP, SpO ₂ , Italian (Rel. D.0)	M3000-6036B	453563377801	M3000-6836B	453563332141
Exchange Measurement Server, ECG, NBP, SpO ₂ , Norwegian (Rel. D.0)	M3000-6037B	453563485781	M3000-6837B	453563332151
Exchange Measurement Server, ECG, NBP, SpO ₂ , Swedish (Rel. D.0)	M3000-6038B	453563485791	M3000-6838B	453563332161

Description	New Parts		Exchange Parts	
	Part Number	12-Digit Reordering Number	Part Number	12-Digit Reordering Number
Exchange Measurement Server, ECG, NBP, SpO ₂ , Finnish (Rel. D.0)	M3000-6039B	453563485801	M3000-6839B	453563332171
Exchange Measurement Server, ECG, NBP, SpO ₂ , Japanese (Rel. D.0)	M3000-6040B	453563485811	M3000-6840B	453563332181
Exchange Measurement Server, ECG, NBP, SpO ₂ , Danish (Rel. D.0)	M3000-6041B	453563485821	M3000-6841B	453563332191
Exchange Measurement Server, ECG, NBP, SpO ₂ , Traditional Chinese (Rel. D.0)	M3000-6042B	453563485831	M3000-6842B	453563332201
Exchange Measurement Server, ECG, NBP, SpO ₂ , Simplified Chinese (Rel. D.0)	M3000-6043B	453563485841	M3000-6843B	453563332211
Exchange Measurement Server, ECG, NBP, SpO ₂ , Portuguese (Rel. D.0)	M3000-6044B	453563485851	M3000-6844B	453563332221
Exchange Measurement Server, ECG, NBP, SpO ₂ , Greek (Rel. D.0)	M3000-6045B	453563485861	M3000-6845B	453563332231
Exchange Measurement Server, ECG, NBP, SpO ₂ , Russian (Rel. D.0)	M3000-6047B	453563377811	M3000-6847B	453563332241
Exchange Measurement Server, ECG, NBP, SpO ₂ , Czech (Rel. D.0)	M3000-6049B	453563485871	N/A	N/A
Exchange Measurement Server, ECG, NBP, SpO ₂ , Polish (Rel. D.0)	M3000-6050B	453563485881	M3000-6850B	453563332251

M3015A Measurement Server Extension Parts

M3015A Parts

Part Number	12-Digit Reordering Number	Description	Item
M3015-44131	453563332291	M3015A Front Bezel with Pressure and Temperature, English (also for French, Danish, Traditional Chinese and Simplified Chinese)	20
M3015-44133	453563332301	M3015A Front Bezel with Pressure and Temperature, German	
M3015-44134	453563332311	M3015A Front Bezel with Pressure and Temperature, Dutch	
M3015-44135	453563332321	M3015A Front Bezel with Pressure and Temperature, Spanish	
M3015-44136	453563332331	M3015A Front Bezel with Pressure and Temperature, Italian	
M3015-44137	453563332341	M3015A Front Bezel with Pressure and Temperature, Norwegian	
M3015-44138	453563332351	M3015A Front Bezel with Pressure and Temperature, Swedish	
M3015-44139	453563332361	M3015A Front Bezel with Pressure and Temperature, Finnish	
M3015-44140	453563332371	M3015A Front Bezel with Pressure and Temperature, Japanese	
M3015-44144	453563332381	M3015A Front Bezel with Pressure and Temperature, Portuguese	
M3015-44145	453563332391	M3015A Front Bezel with Pressure and Temperature, Greek	
M3015-44147	453563332401	M3015A Front Bezel with Pressure and Temperature, Russian	
M3015-44149	453563471561	M3015A Front Bezel with Pressure and Temperature, Czech	
M3015-44150	453563332411	M3015A Front Bezel with Pressure and Temperature, Polish	
M3015-44161	453563402591	M3015A Front Bezel without Pressure and Temperature, English (also for French, Danish, Traditional Chinese and Simplified Chinese)	20
M3015-44163	453563402601	M3015A Front Bezel without Pressure and Temperature, German	
M3015-44164	453563402611	M3015A Front Bezel without Pressure and Temperature, Dutch	
M3015-44165	453563402621	M3015A Front Bezel without Pressure and Temperature, Spanish	

Part Number	12-Digit Reordering Number	Description	Item
M3015-44166	453563402631	M3015A Front Bezel without Pressure and Temperature, Italian	
M3015-44167	453563402641	M3015A Front Bezel without Pressure and Temperature, Norwegian	
M3015-44168	453563402651	M3015A Front Bezel without Pressure and Temperature, Swedish	
M3015-44169	453563402661	M3015A Front Bezel without Pressure and Temperature, Finnish	
M3015-44170	453563402671	M3015A Front Bezel without Pressure and Temperature, Japanese	
M3015-44174	453563402681	M3015A Front Bezel without Pressure and Temperature, Portuguese	
M3015-44175	453563402691	M3015A Front Bezel without Pressure and Temperature, Greek	
M3015-44177	453563402701	M3015A Front Bezel without Pressure and Temperature, Russian	
M3015-44180	453563402711	M3015A Front Bezel without Pressure and Temperature, Polish	
M3015-29303	453563332261	M3015A Pump Kit (including CO ₂ scrubber) <i>(Can only be exchanged in units with serial number prefix DE020xxxxx)</i>	
M3015-29314	453563332281	CO ₂ Infrared Lamp <i>(Can only be exchanged in units with serial number prefix DE020xxxxx manufactured before June 2002)</i>	
5041-8114	453563100081	Mounting Pin for M3015A	21

M3015A Exchange Parts

Description	New Parts		Exchange Parts	
	Part Number	12-Digit Reordering Number	Part Number	12-Digit Reordering Number
Hardware Revision A with Serial Number Prefix DE020xxxxx				
M3015A unit (old hardware) with Pressure and Temperature ^a	M3015-6001A	453563332421	M3015-6801A	453563332431
M3015A unit (old hardware) without Pressure and Temperature ^a	M3015-6031A	453563477861	M3015-6831A	453563477871
Hardware Revision B with Serial Number Prefix DE435xxxxx				
M3015A unit (new hardware) with Pressure and Temperature ^a	M3015-6002A	451261005321	M3015-6802A	451261005311
M3015A unit (new hardware) without Pressure and Temperature ^a	M3015-6032A	451261005341	M3015-6832A	451261005331

a. For all languages apart from English, French, Danish And Chinese, order also the local language bezel as shown under “M3015A Parts” on page 266. Both hardware revisions A and B use the same bezels.

M3015A Showing Front Bezel with Press/Temp, and Mounting Pin

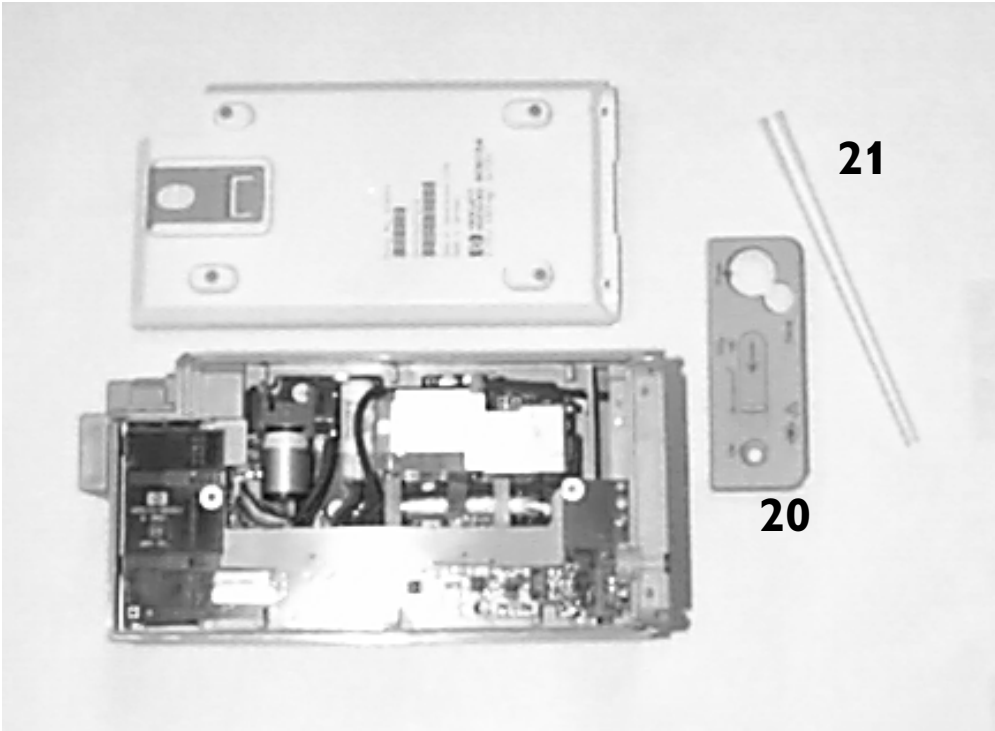

M3016A Measurement Server Extension Parts

The M3016A Measurement Server Extension does not contain any servicable parts and can only be replaced in its entirety.

M3016A Measurement Server Extensions are shipped with English front bezels only. If you require a bezel in another language (compare the part numbers of your language to the English ones to check this), the front bezel has to be ordered additionally. Attach the appropriate bezel before putting the M3016A into operation.

M3016A Parts

Part Number	12-Digit Reordering Number	Description
M3016A #A01 (Press/Temp with Mainstream CO₂)		
M3016-44131	453563332441	M3016A Front Bezel, English (also for French, Danish, Traditional Chinese and Simplified Chinese)
M3016-44133	453563332451	M3016A Front Bezel, German
M3016-44134	453563332461	M3016A Front Bezel, Dutch
M3016-44135	453563332471	M3016A Front Bezel, Spanish
M3016-44136	453563332481	M3016A Front Bezel, Italian
M3016-44137	453563332491	M3016A Front Bezel, Norwegian
M3016-44138	453563332501	M3016A Front Bezel, Swedish
M3016-44139	453563332511	M3016A Front Bezel, Finnish
M3016-44140	453563332521	M3016A Front Bezel, Japanese
M3016-44144	453563332531	M3016A Front Bezel, Portuguese
M3016-44145	453563332541	M3016A Front Bezel, Greek
M3016-44147	453563332551	M3016A Front Bezel, Russian
M3016-44150	453563332561	M3016A Front Bezel, Polish
M3016A #A02 (Press/Temp without Mainstream CO₂)		
M3016-44161	453563482951	M3016A Front Bezel, English (also for French, Danish, Traditional Chinese and Simplified Chinese)
M3016-44162	453563482961	M3016A Front Bezel, German
M3016-44163	453563482971	M3016A Front Bezel, Dutch
M3016-44164	453563482981	M3016A Front Bezel, Spanish
M3016-44165	453563482991	M3016A Front Bezel, Italian
M3016-44166	453563483001	M3016A Front Bezel, Norwegian
M3016-44167	453563483011	M3016A Front Bezel, Swedish
M3016-44168	453563483021	M3016A Front Bezel, Finnish
M3016-44169	453563483031	M3016A Front Bezel, Japanese
M3016-44170	453563483041	M3016A Front Bezel, Portuguese

Part Number	12-Digit Reordering Number	Description
M3016-44174	453563483051	M3016A Front Bezel, Greek
M3016-44175	453563483061	M3016A Front Bezel, Russian
M3016-44177	453563483071	M3016A Front Bezel, Polish
M3016-44179	453563483081	M3016A Front Bezel, German
M3016-44180	453563483091	M3016A Front Bezel, Dutch

M3016A Measurement Server Extension Exchange Parts

Product Option Number	Exchange Part Number	12-Digit Reordering Number	Description
M3016A #A01	M3016-6801A	453563332581	Exchange M3016A Measurement Server Extension, Pressure and Temperature with Mainstream CO ₂ , English ^a
M3016A #A02	M3016-6831A	453563483091	Exchange M3016A Measurement Server Extension, Pressure and Temperature, without Mainstream CO ₂ , English ^a

- a. For all languages apart from French, Danish And Chinese, order also the local language bezel as shown under “M3016A Parts” on page 270.

Support-Related Parts

Part Number	12-Digit Reordering Number	Description
M3046-64107	453563333111	Service Link Bar
M1360-61675	453563277381	Cable for configuration of the M3 Wireless LAN Assembly
M319960102	453563337381	UTP Crossover Cable, orange (approx. 3.7m / 12ft)
M3199-60104	453563337401	UTP Patch Cable (approx. 2.1m / 7.0ft)
Site Survey Tool	N/A	Site Survey Tool is available from Connectronics (www.connectronics.com). The part number is 82-6332 7402-05, Range LAN2/PCMCIA Card (One-piece with Snap-on antenna)
Wireless Board Configuration Tool	N/A	The tool for the wireless board configuration is included on the IntelliVue Information Center CD-ROM
M3080-10801	N/A	VPS Recovery CD

Cables and MSL Through Wall Installation Parts

For further information on cabling, refer also to the IntelliVue Service Guides.

Product Option Number	Part Number	12 Digit Reordering Number	Description
Cables with both ends terminated with straight MSL connectors			
M3081A #A11	M3081-61602	453563377851	2m Measurement Server to Monitor
M3081A #A12	M3081-61603	453563402731	4m Measurement Server to Monitor
	M3081-61626	453563474781	0.75m Measurement Server to Monitor (compatible IntelliVue cable)
Unterminated cables			
M3081A #A15	M3081-61615	453563484481	15m MSL Installation Cable (Through Wall)
M3081A #A25	M3081-61625	453563484491	25m MSL Installation Cable (Through Wall)
Face Plates			
M3081A #C06	M3081-68708	453563484531	MSL Face Plate, US Version (pair of connector boxes)
M3081A #C07	M3081-68708	453563484541	MSL Face Plate, US Version (pair of connector boxes)
Tools			
	M3086-43801	453563484771	Insertion Tool (LSA Plus Tool for connecting cables)
Local Recorder Serial Cable			
	M3000-61613	453563484751	Serial interface cable for connecting the XE-50p local recorder

MMS Measurement Server Link (MSL) Cable Clamp Kit

Part Number	12-Digit Reordering Number	Description
M8000-60012	451261006611	MMS Measurement Server Link (MSL) Cable Clamp Kit (Kit contains: 1 x MSL cable clamp 1 x Screw 1 x Installation Note)

Wireless Assembly Exchange Parts

Exchange Part Number	12-Digit Reordering Number	Description
M3046-69562	453563333471	Exchange Wireless Assembly for Australia
M3046-69563	453563333481	Exchange Wireless Assembly with US country code for FCC countries (Argentina, Brazil, Canada, Chile, China, Columbia, Dominican Republic, Hong Kong, Malaysia, New Zealand, Panama, Taiwan, Thailand, US)
M3046-69564	453563333491	Exchange Wireless Assembly for Singapore country code (France, Mexico, Singapore)
M3046-69566	453563333501	Exchange Wireless Assembly for Spain
M3046-69567	453563333511	Exchange Wireless Assembly for ETSI countries with a UK country code (Austria, Belgium, Czech Republic, Denmark, Finland, Germany, Greece, Iceland, India, Ireland, Italy, Luxembourg, Netherlands, Norway, Portugal, Russia, Sweden, Switzerland, Turkey, UK)
M3046-69568	453563333521	Exchange Wireless Assembly for Japan
M3046-69569	453563333531	Exchange Wireless Assembly for South Korea

Battery and Battery-Related Parts

Battery Parts

Part Number	12-Digit Reordering Number	Description	Item
M3046-61302	453563332751	Monitor Battery	6
M3080 #C32	N/A	12V Adapter	

Battery Exchange Parts

Exchange Part Number	12-Digit Reordering Number	Description	Item
M3046-68302	453563333321	Exchange Battery	6

Battery Charger and Conditioner Parts

Part Number	12-Digit Reordering Number	Description
M8043-60000	453563498901	Smart Battery Charger and Conditioner - New
M8043-60010	451261001281	Replacement Kit: 2 Air-Fans + 2 Filter Mats
M8043-60011	451261001291	Replacement Kit: 2 Filter Mats
M8043-68000	453563498911	Smart Battery Charger and Conditioner - Exchange

XE-50p Recorder Exchange Parts

Exchange Part Number	12 digit Reordering Number	Description
M3080-60100	453563485281	Exchange XE-50p Local Recorder

A

AC Power
connector, 5
LED, 5
Accuracy and Calibration Procedures, 155
Accuracy and Performance Procedures, 155
adjustments, iv
alarm
limit, 10
message, 10
analog ECG signal, 67
anesthetics
operation in presence of flammable, 66
Arterial Oxygen Saturation and Plethysmography (SpO₂/PLETH) Module
Block Diagram, 34, 38
Description, 33, 37
Features, 33
PLETH Waveform, 33
Safety, 33
Measurements, 33, 37
Theory of Operation, 34, 38
assembly, iv

B

Backlight Test, 207
Backlight Tube Assembly, 123
BAD SERVER LINK
INOP description, 177
Barometric Pressure Check and Calibration, 149
Battery
charging, 129
battery
charging
battery conditioner, 131
compartment, 5
conditioning, 131
LED, 5
trickle charging and care, 132
BATTERY EMPTY
INOP description, 177
Battery Handling, 127
Battery handling, 127
Battery Level Low message, 210
BATTERY LOW
INOP description, 177
BATTERY MALFUNCT.
INOP description, 178
Battery Status
checking, 127
window, 132
brain examination, 65

C

cabinet grounding, 64
cabinet installation, 66
Cause of Failure, 183
CHARGER MALFUNCT
INOP description, 178
Check for Obvious Problems, 166
CHECK INPUT DEVICE
INOP description, 178
Check Status Log message, 210
Checks before opening the instrument, 166

Cleaning Agents, 126
Cleaning agents, 126
Cleaning of the System, 125
clearance, 66
CO₂
Calibration Verification, 153
Flow Rate Check and Calibration, 151
Noise Check, 152
Pump check, 151
CO₂ AUTOZERO
INOP description, 181
CO₂ CAL FAILED
INOP description, 180
CO₂ CAL MODE
INOP description, 180
CO₂ CAL RUNNING
INOP description, 180
CO₂ CHANGE SCALE
INOP description, 180
CO₂ CHECK CAL
INOP description, 180
CO₂ EQUIP MALF
INOP description, 179
CO₂ Gas Measurement Calibration
Check, 152
CO₂ NO TRANSDUCER
INOP description, 179
CO₂ NO TUBING
INOP description, 181
CO₂ OCCLUSION
INOP description, 181
CO₂ OVERRANGE
INOP description, 181
CO₂ PURGING
INOP description, 182
CO₂ Scrubber
replacement, 125
CO₂ SENSOR WARM UP
INOP description, 180
CO₂ UPDATE FW
INOP description, 180
CO₂ WAIT CAL 2
INOP description, 180
Coldstart Test, 206
combining equipment, 65
Compatibility Matrix, 245
Compatibility problems, 186
condensation, 66
configuration, 87
connecting measurement server, 71
connector
AC Power, 5
measurement, 7
measurement server, 6, 7, 92
nurse call, 6, 92
Quick Link, 6, 7, 92
software update, 6, 92
transducer, 7
corrosive gases, 66

D

default setting, 10
Defib Data In, 67
defib synch, 5
defibrillation protection, 64
defibrillator, 67
Delta, 46, 54

Delta Temp, 45, 53
Delta Temp calculation feature, 46, 54
Disassembly Procedures, 221
Display Assembly related problems, 186, 188
Display Test, 207
disposal, 115

E

earthing, 64
EASI lead placements, 23
ECG
data out, 67
EASI, 23
signal
analog, 67
ECG EQUIP MALF message, 210
ECG Sync
Performance Test, 158
ECG synch, 158
ECG/Resp
Performance check, 155
theory of operation, 23
Electrocardiogram/Respiration (ECG/RESP) Module
Block Diagram, 25
Components, 25
Description, 23
Features, 24
ECG Modes, 24
RESP Modes, 24
Safety, 25
Measurements, 23
Theory of Operation, 25
electrosurgery protection, 64
equipment
combining, 65
equipotential grounding post, 5
Error Code Description, 198
Error Codes, 197
listing, 199
explosive gases, 66
extensions, iv

F

floating inputs (Type CF), 64
Front-Panel LEDs
troubleshooting, 168
fuse, 221
fuse, part number, 250

G

gases
explosive, 66
grounding, 64
cabinet, 64
grounding post, 5

H

heart examination, 65
Human Interface Controller, 18

I

- Infrared Lamp
 - replacement, 125
- INOP Messages, 177
- inputs
 - floating, 64
- Inspect the Cables and Cords, 122
- Inspect the System, 122
- installation, iv
 - cabinet, 66
- Installing the Instrument, 63
- Instrument Components, 4
- intra-aortic balloon pump, 67
- Isolating and Solving Instrument Problems, 177
- Isolating problems to the correct subassembly, 175

L

- label
 - numeric, 10
 - wave, 10
- leakage current
 - patient, 64
- LED
 - AC Power, 5
 - battery, 5
- LEDs, System Board, 169
- Line Frequency, 209

M

- M3000A Measurement Connectors, 7
- M3015A
 - Measurement Connectors, 9
 - Theory of Operation, 45
- M3016A
 - measurement connectors, 10
 - theory of operation, 53
- Main Screen button, 5
- Mainstream CO₂
 - Performance Test, 157
- Mainstream CO₂ Measurement, 56
- Maintenance
 - Frequency, 120
 - NBP calibration and performance tests, 123
 - preventive, 123
- Maintenance Checklist, 121
- marker pulse (ECG), 67
- MEAS SERV UNPLUGGED
 - INOP description, 178
- measurement connector, 7
- Measurement extensions
 - description and features, 44
- Measurement Server
 - description, 19
 - theory of operation, 21
- measurement server
 - connecting, 71
 - connector, 6, 7, 92
 - mounting, 6, 92
- Measurement Server LEDs
 - troubleshooting, 172
- modifications, iv
- Monitor
 - hardware functional description, 16
 - Rear Panel, 6
 - theory of operation, 11
- Monitor Revisions Screen, 209
- monitor, overview, 3, 11
- mounting
 - measurement server, 6, 92
 - monitor, 6, 92
- mounting options, 63

N

- NBP
 - Accuracy Test, 146
 - Leakage Test, 147
 - Linearity Test, 148
 - start/stop button, 7
 - valve test, 148
- Non-invasive Blood Pressure (NBP) Modules
 - Block Diagram, 31
 - Components, 31
 - Description, 29
 - Features, 29
 - NPB Modes, 30
 - Safety, 30
 - Measurements, 29
 - Theory of Operation, 32
- numeric, 10
- numeric label, 10
- nurse call
 - connector, 6, 92
- Nurse Call Relay
 - connecting, 76
 - modification, 76
 - Performance Test, 157

O

- On-Off/Standby button, 5

P

- Parts
 - listing, 247
- parts and accessories, iv
- Passwords, 142
- patient
 - leakage current, 64
 - name, 10
 - safety, 64
- Patient safety checks, 159
- performance, iv
- Performance Assurance Test, 143
- Power On Test, 142
- Power Supply related problems, 188
- PRESS
 - zero button, 7
- Press
 - performance check, 156
- Press/Temp, Extension, 45, 53
- Pressure
 - theory of operation, 37
- Pressure Zero & Check Cal message, 210
- Preventative Maintenance, 123
- Preventive Maintenance Tests, 146
- printer
 - connecting, 95

- port, 5
- selecting, 93
- Printer Connection
 - troubleshooting, 214
- Printer Manager, 14
- protection class (IEC 601-1, class 1), 64
- protective earth, 64
- protective grounding, 64
- Pump
 - replacement, 125

Q

- Quick Link connector, 6, 7, 92

R

- Recorder
 - troubleshooting, 195
- reliability, iv
- Remedy, 183
- Removing the Backlight Tubes, 226, 230
- Removing the Battery, 221
- Removing the Chassis, 222
- Removing the Connector Board, 228
- Removing the LCD Assembly, 226
- Removing the Power Supply, 221
- Removing the Speaker, 229
- Removing the System Board, 224
- repairs, iv
- Reset PumpOpTime, 208
- RESP EQUIP MALF message, 210
- Revision Screen, 209

S

- safety, iv
 - patient, 64
- Safety Analyzer, 159
- Safety Tests
 - Procedures, 159
- Serial Numbers, 142
- SERVERLINK MALF
 - INOP description, 179
- Service Mode, 206
- setting
 - default, 10
- Setup button, 5
- Sidestream CO₂ Measurement, 48
- Sidestream CO₂ Performance Test, 148
- Silence/Reset button, 5, 7
- Site Preparation Guideline, 97, 214, 215
- SmartKey
 - label, 10
- software update
 - connector, 6, 92
- Speaker Assembly, 193
- SPEAKER MALFUNCTION
 - INOP description, 179
- SpO₂
 - Performance Test, 157
- SpO₂ NOISY SIGNAL message, 180
- SpO₂/PLETH
 - theory of operation, 33
- Standby, 67
- Start/Stop button, 7
- Status Log, 197
- Support Functions, 197

Suspend button, 5
Symptoms, 183
System PCB related problems, 183
System Self-Test, 144

T

TEMP EQUIP MALF message, 211
Temp/Press, Extension, setting P2 zero and labels, 45, 53
Temperature
 Accuracy check, 155
 theory of operation, 37
temperature extremes (operating environment), 66
Tests

 checklist, 141
 reporting in service record, 138
 time, 10
Time counters
 resetting, 153
touchstrip, 5
TouchStrip problems, 189
TouchStrip related problems, 189
transducer connector, 7
trickle charging, 132
Troubleshooting Checklists, 166

U

unpacking, 70
UNSUPPORTED LAN

 INOP description, 179

V

vibration, 66
Visual Test, 142

W

wave, 10
 label, 10

Z

Zero button, 7
Zero key, 45, 53