



Camera remote control

- 36-fold optical zoom
- focus-control (automatic/manual)
- iris-control (automatic/manual)
- colour-control
- frozen image
- with image rotation



Example for diagnosis with the OT video system

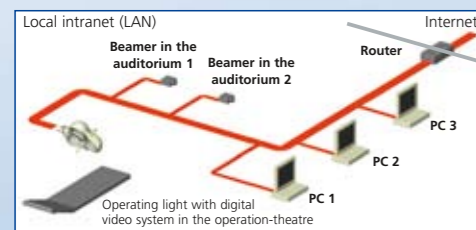

Digital video system connected to the network

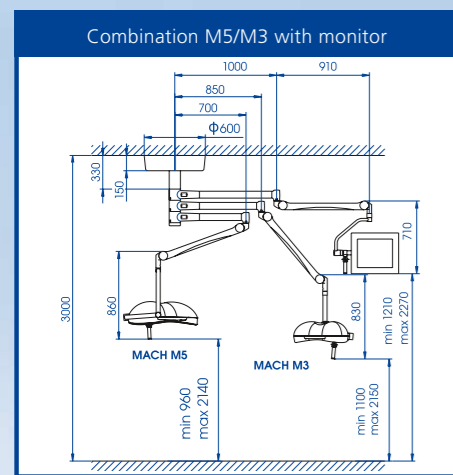

Dimensions in millimeter

Mach M5/M3

Dr. Mach
Medical lighting
+ Technology

Mach M5/M3

Operating light systems in combinations

Halogen lights

- Mach M5
- Mach M3

Gas discharge lights

- Mach M5X
- Mach M3X

Mach video transmission system

Subject to change without notice due to technical modification - 59000273 A01 - Version: 06/2008

Dr. Mach GmbH & Co. KG

Flossmannstr. 28 · D-85560 Ebersberg
Phone: +49 (0) 8092 / 2093-0 · Fax: +49 (0) 8092 / 2093-50
www.dr-mach.com · e-mail: info@dr-mach.de

Focus on the light!

Dr. Mach sets standards in the medical illumination technology since decades.

Dr. Mach operating and examination lights support your professionalism by innovative technology and design. Natural colour reproduction and exact illumination of the wound field with the Duo-Focus-Technology make your work easier and convey safety and trust to your patient.

Your **Dr. Mach** Team
Medical lighting
+ Technology

Introduction 2 – 3

Advantages 4 – 5

Halogen lights

Mach M5/M3 6 – 9

Gas discharge lights

Mach M5X/M3X 10 – 13

Mach video transmission system

..... 14 – 15

Advantages

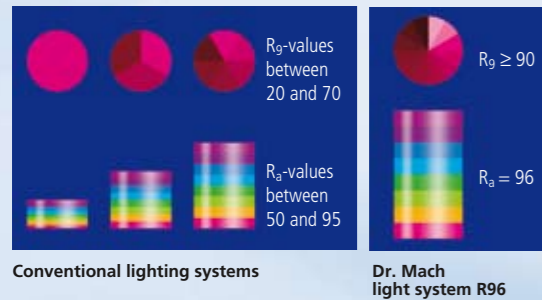

Light quality and optics

Superior colour rendition

With a previously unattainable colour rendition $R_a = 96$ and $R_g(\text{red}) \geq 90$ you easily see the tiniest nuances of colour in tissue. For recognizing the exact colour spectrum of the wound the exact rendition of the red colour range is essential. $R_g(\text{red}) \geq 90$ means for the surgeon a visibly better recognition of details. The colour spectrum of the wound is rendered naturally. The OT-light clearly provides welcome relief for your eyes.



Multi-reflector system

Reflectors arranged in circular position increase as multiple-reflector system the contrast of the light.



Duo-Focus-Technology:

Merging of the individual luminous fields

By turning of the sterilizable handle the reflectors swivel. The three light fields are joined and overlap to one field with increased light intensity.

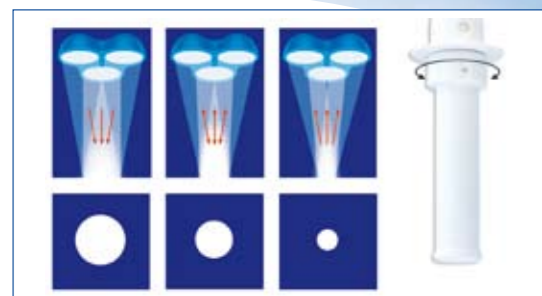

Focussing (optional)

By turning of the adjustment ring at the sterilizable handle the bulbs are moved inside the reflector up and down. The focusable light beam allows a punctual illumination of deepest wound channels with high intensity and an exact matching of the light field diameter with the size of the wound field.



Additional comfort



Multi-faceted reflector system

Over 3000 facettes per reflector guarantee a homogeneous light field and avoid disturbances through shadows in the light field.



Endolight (Mach M5 only)

For certain OT situations (i.e. endoscopy) an additional light integrated in the lamp cover can be switched on to obtain a diffused room lighting.



Cool light

Coated cold light reflectors reduce in connection with dielectrically coated cold light filters the heat radiation to a minimum. The unwanted infrared radiation of the light source is not reflected by the reflectors but released to the upper side (ceiling). The heat increase under the lamphead is avoided. The surgeons head area remains cool.



Flow properties

The form of the housing shows excellent flow properties and produces optimum conditions for laminar flow systems.



Easy maintenance

Without tools and with only a few steps the lamp housings can be opened to have access to all system components. Due to the module technology all components can be easily exchanged. Within 30 seconds you exchange the bulb. The housings are easy to clean.



Housing of die-casted aluminium

The material guarantees shock resistance and long life. The heat is emitted through the upper housing part to the ceiling, thus negligible heat in the surgeon's head and shoulder area.



Please find additional advantages for the gas discharge lights on page 11.

OT-light combinations with halogen bulbs



Mach M5

Mach M3

The light beams of the three reflectors can be merged by the sterilizable handle and – optionally – also focussed.

Performance description

Mach M5 F/M3 F

Merging of light fields



Superior colour rendition



Multi-facetted reflector system



Cool light

Optimum flow properties

Easy maintenance

Housing of die-casted aluminium

The material guarantees sturdyness and long life. The heat is emitted through the upper housing part to the ceiling, thus negligible heat in the surgeon's head and shoulder area.

Mach M5 DF/M3 DF

Additionally to the advantages of the F-model:

Focussing

- punctual illumination of deepest wound channels
- exact adjustment of the light field to the size of the wound area



Options against surcharge

Endolight (only for Mach M5)



Electronic light intensity control
with on/off-switch

Mechanical on/off-switch at the lamphead

OT-light combinations with halogen bulbs



Mach M5

Mach M3 with camera



Mach M3

OT-light combinations Mach M5/M3

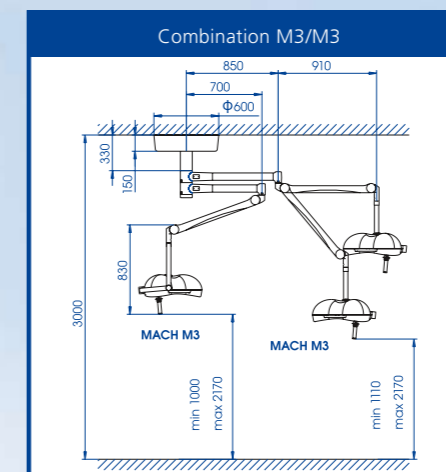
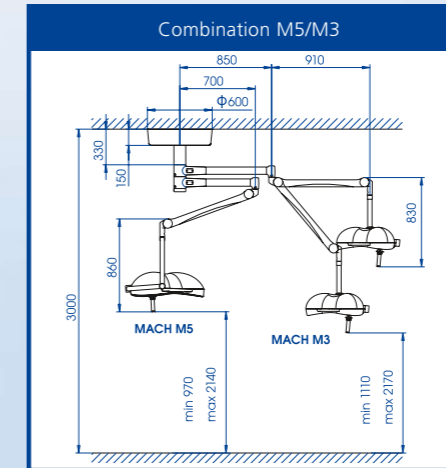

Dimensions in millimeter

Two possible alternatives:
Mach M5 or Mach M3 as the main light
with the satellite Mach M3.

OT-light combinations with halogen bulbs



Mach M5



Mach M3 with camera



Mach M3 with camera



Mach M3

Two possible alternatives:
Mach M5 or Mach M3 as the main light
with the satellite Mach M3.

Technical data		
Mach M5 light system ⁽¹⁾	Mach M5 DF ⁽²⁾	Mach M5 F ⁽³⁾
Light intensity Lux at 1 meter distance	160.000	150.000
Colour rendering index R _a ⁽⁴⁾ at 4300 Kelvin	96	96
Colour rendering index R _g ⁽⁵⁾ at 4300 Kelvin	≥ 90	≥ 90
Focussable size of the light field (in cm)	15 - 34	17 - 32
Colour temperature (Kelvin)	4300	4300
Electronic light intensity control at the lamp head	surcharge	surcharge
Photometric radiation equivalent	280 lm/W	280 lm/W
Temperature increase in head area	2° C	2° C
Total power consumption	215 W	215 W
Light source IRC 23V / 80W	3	3
Working distance (in cm)	60 - 150	70 - 140
Height adjustment (in cm)	118	118
Lamp head diameter (in cm)	80	80

Technical data		
Mach M3 light system ⁽¹⁾	Mach M3 DF ⁽²⁾	Mach M3 F ⁽³⁾
Light intensity Lux at 1 meter distance	130.000	100.000
Colour rendering index R _a ⁽⁴⁾ at 4300 Kelvin	96	96
Colour rendering index R _g ⁽⁵⁾ at 4300 Kelvin	≥ 90	≥ 90
Focussable size of the light field (in cm)	12 - 30	17 - 28
Colour temperature (Kelvin)	4300	4300
Electronic light intensity control at the lamp head	surcharge	surcharge
Photometric radiation equivalent	280 lm/W	280 lm/W
Temperature increase in head area	2° C	2° C
Total power consumption	150 W	150 W
Light source Halogen 22,8V / 50W	3	3
Working distance (in cm)	60 - 150	70 - 140
Height adjustment (in cm)	118	118
Lamp head diameter (in cm)	64	64

(1) external transformer
 (2) DF-models with Duo-Focus system: merging of light fields and focussing
 (3) F-models with merging of light fields
 (4) R_a is an average of R₁ = burnt pink, R₂ = mustard yellow, R₃ = yellow green, R₄ = light green, R₅ = turquoise blue, R₆ = skyviolet, R₇ = violet, R₈ = lilac. Maximum value = 100.
 (5) R_g is the value for the rendering of the colour red. This is not used in calculating the general colour rendering index R_a. The values for conventional operating lights are between 20 and 70. Maximum value = 100. Values of more than 90 allow the surgeon to recognise details better in the wound area.

OT-light combinations with gas discharge bulbs



Mach M5X

Mach M3X

The light beams of the three reflectors
can be merged by the sterilizable handle and
– optionally – also focused.

Gas discharge lights

Performance

Mach M5X F
Merging of light

Superior colour

Multi-faceted

Cool light

Optimum flow

Easy maintenance

Housing of di

The material guaran
through the upper
surgeon's head and

Additional fea

- longer service lif
- bridging the init
- setting the oper
- electronic light i

Mach M5X D

Additionally to the

Focussing

- punctual illumina
- exact adjustmen

Options ag

Endolight (only

Mechanical on

Additional advantages

Mach M5X/M3X

The gas discharge technology offers additional
features beside those mentioned on page 4/5.

Longer service life

The service life of the gas discharge bulbs is
approx. 5000 hours.

Bridging the initial phase
(Mach M5X only)

The initial phase of the gas discharge bulbs is
bridged at Dr. Mach lights by the halogen bulbs.
The halogen bulbs turn off automatically once the gas
discharge bulbs have reached their full light intensity.

Setting the operation mode
(Mach M5X only)

The surgeon can choose the operation mode
(halogen mode, mixed mode or gas discharge mode).

The **Mach M3X** works only with gas discharge bulbs
(starting phase approx. 2 seconds)

OT-light combinations with gas discharge bulbs



Mach M5X

Mach M3X

The light beams of the three reflectors can be merged by the sterilizable handle and – optionally – also focused.

Performance description

Mach M5X F/M3X F
Merging of light fields



Superior colour rendition



Multi-facetted reflector system



Cool light

Optimum flow properties

Easy maintenance

Housing of die-casted aluminium

The material guarantees sturdyness and long life. The heat is emitted through the upper housing part to the ceiling, thus negligible heat in the surgeon's head and shoulder area.

Additional features of the X-models

- longer service life
- bridging the initial phase (Mach M5X only)
- setting the operation mode (Mach M5X only)
- electronic light intensity control with on/off switch

Mach M5X DF/M3X DF

Additionally to the advantages of the F-model:

Focussing

- punctual illumination of deepest wound channels
- exact adjustment of the light field to the size of the wound area

Options against surcharge

Endolight (only for Mach M5)



Mechanical on/off-switch at the lamphead

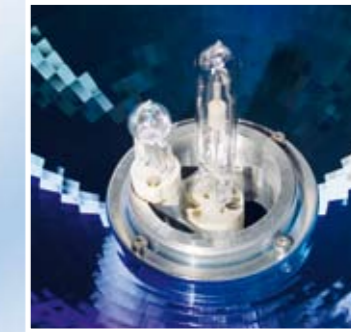

Halogen and gas discharge bulb (Mach M5X)

Keypad for the X-models with gas discharge bulbs



The LED display shows the remaining service life: one LED stays for 1000 hours of operation.

The LED display shows the current operation mode.

These two buttons are used for focussing the light field (DF models only).

Pressing the „Focus-enlarge“ button and the dimmer button at the same time changes the operation mode of the light:

- Halogen mode H
- Mixed mode H/G
- Gas discharge mode G

These two buttons are used for setting the light intensity. The set value is shown by the LED display.

Special features not shown

OT-light combinations with gas discharge bulbs



Mach M5X

Mach M3X with camera



Mach M3X

Two possible alternatives:
Mach M5 or Mach M3 as the main light
with the satellite Mach M3

OT-light combinations Mach M5X/M3X

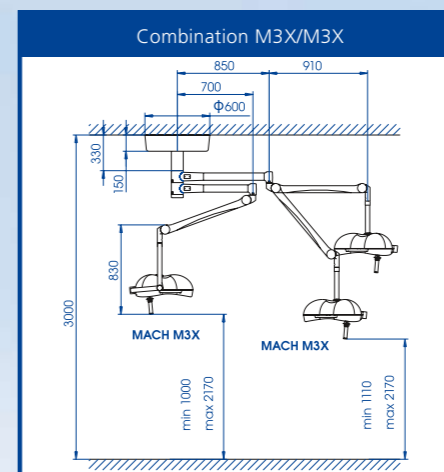
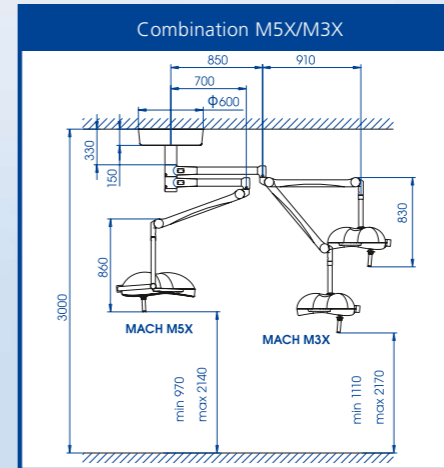

Dimensions in millimeter

OT-light combinations with gas discharge bulbs



Mach M5X

Mach M3X with camera

Two possible alternatives:
Mach M5X or Mach M3X as the main light
with the satellite Mach M3X.



Mach M3X with camera



Mach M3X

Technical data		
Mach M5X light system ⁽¹⁾	Mach M5X DF/H ⁽²⁾	Mach M5X F/H ⁽²⁾
Light intensity Lux at 1 meter distance	160.000	150.000
Colour rendering index R _a ⁽³⁾ at 4300 Kelvin	≥ 93	≥ 93
Colour rendering index R _g ⁽³⁾ at 4300 Kelvin	≥ 90	≥ 90
Focussable size of the light field (in cm)	15 - 34	17 - 32
Colour temperature (Kelvin)	4300	4300
Electronic light intensity control at the lamp head	standard	standard
Photometric radiation equivalent	280 lm/W	280 lm/W
Temperature increase in head area	2° C	2° C
Power consumption gas discharge	105 W	105 W
Power consumption halogen	240 W	240 W
Power consumption mixed mode H/G	400 W (temporary)	400 W (temporary)
Light source gas discharge 35W	3	3
Light source IRC 23V / 80W	3	3
Working distance (in cm)	60 - 150	70 - 140
Height adjustment (in cm)	118	118
Lamp head diameter (in cm)	80	80

Technical data		
Mach M3X light system ⁽¹⁾	Mach M3X DF/H ⁽²⁾	Mach M3X F/H ⁽²⁾
Light intensity Lux at 1 meter distance	145.000	130.000
Colour rendering index R _a ⁽³⁾ at 4300 Kelvin	≥ 93	≥ 93
Colour rendering index R _g ⁽³⁾ at 4300 Kelvin	≥ 90	≥ 90
Focussable size of the light field (in cm)	12 - 30	17 - 28
Colour temperature (Kelvin)	4300	4300
Electronic light intensity control at the lamp head	standard	standard
Photometric radiation equivalent	280 lm/W	280 lm/W
Temperature increase in head area	2° C	2° C
Power consumption gas discharge	105 W	105 W
Light source gas discharge 35W	3	3
Working distance (in cm)	60 - 150	70 - 140
Height adjustment (in cm)	118	118
Lamp head diameter (in cm)	64	64

(1) external transformer
 (2) DF-models with Duo-Focus system: merging of light fields and focussing
 (3) F-models with merging of light fields
 (4) R_a is an average of R₁ = burnt pink, R₂ = mustard yellow, R₃ = yellow green, R₄ = light green, R₅ = turquoise blue, R₆ = skyviolet, R₇ = violet, R₈ = lilac. Maximum value = 100.
 (5) R_g is the value for the rendering of the colour red. This is not used in calculating the general colour rendering index R_a. The values for conventional operating lights are between 20 and 70. Maximum value = 100. Values of more than 90 allow the surgeon to recognise details better in the wound area.

OT-light combination with monitor and integrated video system



Mach M5



Monitor

A professional combination:
the main light Mach M5 or Mach M5X,
the first satellite Mach M3 or M3X and
the monitor as second satellite.



Integrated OT-camera

Free turning



Mach M3

The other...
A Sony camera with...
is used. Via remote...
auditorium or other

Digital video s

By a new digital cam...
for the computer or...
video signals. These...
and a network cable

Advantages:

You don't need a vic...
on the computer if s...
record the signals or...
equipped with two S

Available digi

Video system DIG
Every computer in th...
can be saved on a h

Video system DIG

As with the video sy...
to the video images...
city. Additionally the...
through the PC-scre...
remote control.

Mach M5/M3 combination



Camera remote control

- 36-fold optical zoom
- focus-control (automatic/manual)
- iris-control (automatic/manual)
- colour-control
- frozen image
- with image rotation

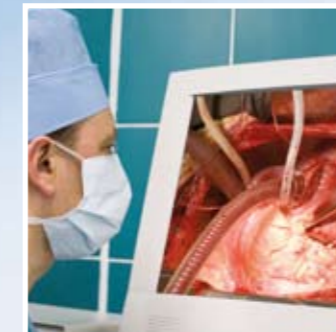

Example for diagnosis with the OT video system

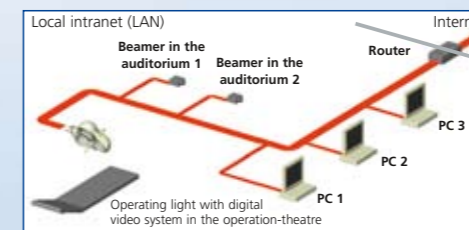

Digital video system connected to the network

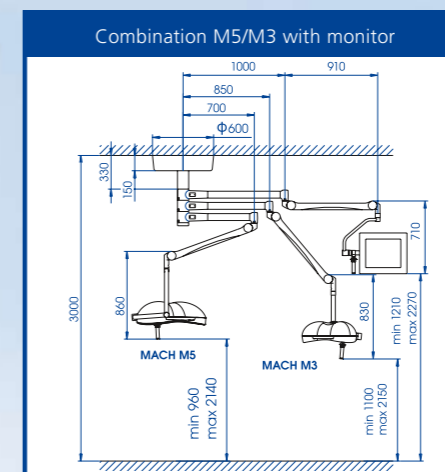

OT-light combination with monitor and integrated video system



Mach M5



Monitor

A professional combination:
the main light Mach M5 or Mach M5X,
the first satellite Mach M3 or M3X and
the monitor as second satellite.



Integrated OT-camera



Output for video and control signals

Free turning and swivelling



Mach M3

Integrated video system

The video- and control signals are not transmitted conventionally by separate cables – but via the electric lines and sliding contacts of the operating light.

Advantages:

The operating light permits continuous rotary movement. The upgrading with the camera is significantly cheaper and easier.

The camera doesn't need readjustment depending on the distance between lamphead and wound area as it is positioned centrally in the lamphead.

The camera can be removed at any time and installed with other OT-lights with video preparation (option).

A Sony camera with 36-fold optical zoom, autofocus, autoiris and image rotation is used. Via remote control panel it can be controlled at the same time from an auditorium or other rooms.

Digital video system **NEW**

By a new digital camera remote control you can now receive digital video signals for the computer or network. Analog camera images are converted in MPEG4-video signals. These are available through a RJ45 interface at the remote control and a network cable.

Advantages:

You don't need a video card any longer. The images can be directly saved on the computer if sufficient capacity is available. Nevertheless you can further record the signals on video or DVD-recorders. For this the remote control panel is equipped with two S-video (Y/C) connectors.

Available digital video systems

Video system DIGITAL ECO

Every computer in the network has access to the video images and they can be saved on a hard disc drive of sufficient capacity.

Video system DIGITAL PC-CONTROL

As with the video system Digital Eco every computer in the network has access to the video images and they can be saved on a hard disc drive of sufficient capacity. Additionally the camera can be controlled by a specially designed software through the PC-screen. This is done by an IP-address designated for the camera remote control.

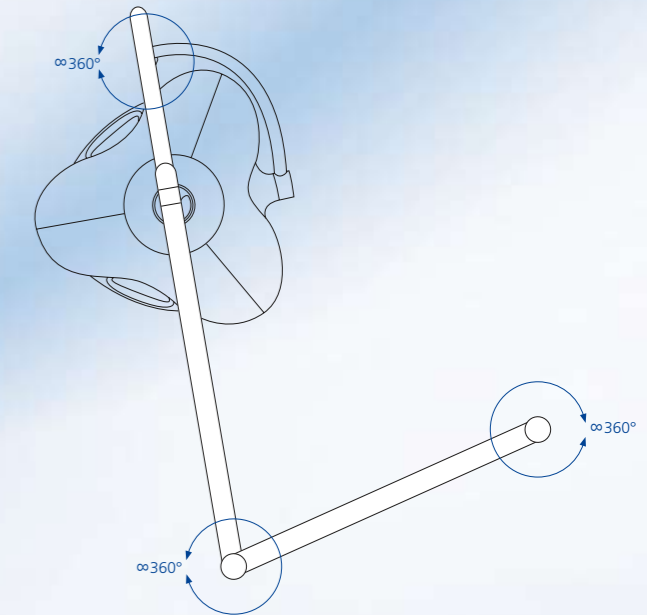

Continuous rotation

Technical data		
Dr. Mach camera	MFB-MO ⁽¹⁾	OFB-ST ⁽²⁾
Colour image camera for visual communication (PAL/NTSC)		
Objectiv systems	NEW 36-fold optical zoom 12-fold digital zoom f = 3.4 to 122.4 mm F1.6-4.5 Auto Focus (Integr. focussing system)	72-fold zoom Auto Focus (Integr. focussing system)
Video exit 75 Ohm	VBS: 1.0 Vp-p. Sync. Negative Y/C Output	VS1.0 Vp-p. Sync. Negative C: Burst 0.300 Vp-p VBS: 1.0 Vp-p Composite
Image points	752 (H) x 582 (V)	752 (H) x 582 (V)
Horizontal resolution	NEW Over 530 lines	Over 460 lines
Humidity	20 - 85%	20 - 85%
Dimesions (Ø, Length)	80 x 150 mm	80 x 150 mm
Weight	900 g	900 g
Interference radiation in acc. with	FCC class A	FCC class A

(1) with remote control, with image rotation
(2) without remote control, without image rotation

No additional cables are needed for the camera. By a special electronic design the power supply of the operating light is used for the transmission of the control- and video signals.