

# Bexen cardio

## AED Defibrillator

REANIBEX 100



## USER MANUAL

DJH 0100 B – REV: C / 2022.JAN

***Blank page***

# REANIBEX 100

## USER GUIDE

Review	Date	Approved by	Signature
C	January 2022	Digna González R&D Manager	

***Blank page***

The REANIBEX 100 complies with the requirements of the Medical Device Directive 93/42/EEC and carries the  1434 mark accordingly.

**Revision C**

**January 2022**

All rights are reserved for this publication.

This manual may not be totally or partially reproduced, in any way or by any means, without prior written authorization from of Bexen cardio.

The information contained in this manual may be modified by the manufacturer without requiring prior notice. If the information in this User Guide does not correspond to the operation of the device, please contact an authorised representative of Bexen cardio.

## **REANIBEX 100**

This is a product of:

**Bexen cardio**

OSATU S.Coop

Edificio Zearrekobuelta

Subida de Areitio N° 5

48260 Ermua (Bizkaia) – SPAIN

Tel.: +34 943 17 02 20

Fax: +34 943 17 02 27

E-mail: [info@bexencardio.com](mailto:info@bexencardio.com)

[www.bexencardio.com](http://www.bexencardio.com)

***Blank page***

<b>1</b>	<b>INTRODUCTION .....</b>	<b>3</b>
1.1	OVERVIEW .....	3
1.2	INTENDED USE.....	3
1.3	SAFETY CONSIDERATIONS.....	4
1.4	ADDITIONAL INFORMATION REQUEST .....	8
<b>2</b>	<b>DESCRIPTION OF THE EQUIPMENT .....</b>	<b>9</b>
2.1	BASIC ORIENTATION.....	9
2.1.1	INDICATORS AND CONTROLS.....	9
2.1.2	CONNECTORS .....	10
2.2	BATTERIES .....	11
2.2.1	BATTERY DURATION .....	12
2.3	PADS.....	13
<b>3</b>	<b>INSTALLATION OF THE EQUIPMENT .....</b>	<b>14</b>
3.1	CONNECTING THE PADS .....	14
3.2	INSTALLING THE BATTERY .....	15
<b>4</b>	<b>AUTOMATIC EXTERNAL DEFIBRILLATION.....</b>	<b>17</b>
4.1	INTENDED USE.....	17
4.2	WARNINGS AND PRECAUTIONS.....	17
4.3	PREPARING FOR AUTOMATIC EXTERNAL DEFIBRILLATION.....	18
4.4	AUTOMATIC EXTERNAL DEFIBRILLATION PROCEDURE .....	20
4.5	TROUBLESHOOTING .....	21
<b>5</b>	<b>CONFIGURATION .....</b>	<b>22</b>
5.1	ACCESSORIES TO CONFIGURE THE DEVICE .....	22
5.2	CONFIGURABLE PARAMETERS .....	22
5.2.1	AED CONFIGURATION .....	22
5.3	TESTS.....	23
5.3.1	TEST MODE.....	23
5.3.2	SELF- TESTS .....	24
<b>6</b>	<b>DATA MANAGEMENT.....</b>	<b>26</b>
6.1	DESCRIPTION.....	26
6.2	STORED EVENTS .....	26
<b>7</b>	<b>MAINTENANCE .....</b>	<b>27</b>
7.1	OVERVIEW .....	27
7.2	MAINTENANCE ROUTINE.....	27
7.2.1	CHECK LIST.....	27
7.3	CLEANING INSTRUCTIONS.....	28
7.4	STORAGE.....	29
7.5	BATTERY MAINTENANCE .....	29
7.6	SERVICE AND REPAIR .....	30
7.7	PRODUCT RECYCLING INFORMATION .....	31
7.8	WARRANTY.....	31
7.9	ACCESSORIES, CONSUMABLES AND COMPLEMENTARY TOOLS.....	31

<b>8</b>	<b>TROUBLESHOOTING .....</b>	<b>32</b>
8.1	GENERAL PROBLEMS .....	32
8.2	AUTOMATIC DEFIBRILLATION PROBLEMS.....	33
<b>A.1</b>	<b>SYMBOLS.....</b>	<b>35</b>
<b>A.2</b>	<b>MESSAGES .....</b>	<b>37</b>
<b>A.3</b>	<b>SPECIFICATIONS AND CHARACTERISTICS .....</b>	<b>40</b>
<b>A.4</b>	<b>DEFIBRILLATION WAVE.....</b>	<b>43</b>
<b>A.5</b>	<b>RHYTHM DETECTION SYSTEM .....</b>	<b>44</b>
<b>A.6</b>	<b>ELECTROMAGNETIC COMPATIBILITY GUIDE .....</b>	<b>45</b>
<b>A.7</b>	<b>CONNECTIVITY GUIDE .....</b>	<b>48</b>
<b>A.8</b>	<b>CYBERSECURITY .....</b>	<b>55</b>
<b>A.9</b>	<b>ACCESSORIES, CONSUMABLES AND COMPLEMENTARY TOOLS .....</b>	<b>63</b>

**Figures**

Figure 1: Front View with the cover opened..... 9

Figure 2: Front View with the cover closed ..... 10

Figure 3: Pads and USB connectors selectable by a sliding lid. .... 11

Figure 4: Therapy cable connection ..... 15

Figure 5: Battery installation ..... 16

Figure 6: Placing the pads..... 19

Figure 7: Defibrillation wave ..... 43

*Blank page*

## 1 INTRODUCTION

The REANIBEX 100 is a public access defibrillator intended to be used in adult or paediatric cardiac arrest patients who are unconscious, not breathing and not presenting signs of circulation (for example, coughing or movement).

This guide contains the instructions necessary for the safe and appropriate use of the equipment, as well as information on its configuration and maintenance. The guide includes the information and procedures for all the features of the REANIBEX 100. The device you have purchased may not have all the features contained in this manual.

### WARNING

Accessories of the REANIBEX 100 are not interchangeable with the accessories used in other REANIBEX equipment.

### 1.1 OVERVIEW

When connected to a patient, the REANIBEX 100 automatically analyses the patient's electrocardiogram (ECG) and decides whether delivering an electrical shock is necessary or not. If an electrical shock is recommended, the device will automatically charge the required energy. Depending on the version of the equipment (semi or fully automatic), pressing a button may be required to provide the defibrillation. The device will guide the user through the episode by providing voice messages.

The REANIBEX 100 operates with disposable LiMnO<sub>2</sub> batteries.

The REANIBEX 100 has an internal memory that stores the data acquired during the intervention, including patient ECG signals and relevant events. In addition to these data, the equipment stores the last 50 tests performed at the request of the user or during a Self Test.

In addition to the patient-related operating mode described above, the REANIBEX 100 has a special switch-on function that accesses the Test mode. This mode can be used to obtain information regarding the status of the device.

The REANIBEX 100 performs a series of Self Tests to detect any failures or anomalous conditions in the equipment that may compromise safe operation. Errors are indicated by voice messages.

These tests are performed when the device is switched on and during operation. Additionally, the REANIBEX 100 performs the following Self Tests:

- Daily Self Test; this test is performed every day.
- Monthly Self Test; this verification is carried out once a month and includes the daily Self Test.

### 1.2 INTENDED USE

The REANIBEX 100 is intended for use by laypeople with a minimal knowledge and training in cardiopulmonary resuscitation (CPR) and basic life support who know how to use the REANIBEX 100 Automatic external defibrillator (AED) or that has been authorized by a competent body . It is also

intended to be used by medical personnel that may have training in basic life support or advanced life support.

The REANIBEX 100 is intended for use in hospital and out-of-hospital environments that meet the environmental conditions described in this guide.

When considering location, avoid areas that expose the REANIBEX 100 to moisture, dust, or extreme temperatures. Long-term storage at the high temperatures may reduce the life of the pads.

If the REANIBEX 100 has wireless capability, it should be placed in a location that has adequate signal strength.

The device is intended to be used in both adult and paediatric patients, as long as the appropriate operating mode is selected. The device will adjust the energy levels, metronome characteristics and all the necessary patient parameters according to the type of patient selected: adult or paediatric.

For further information on the intended use of the device, indications for use and contraindications of the treatment function please refer to the corresponding sections in this guide that explain these functions.

## WARNING

The REANIBEX 100 must be used on a single patient at a time.

## 1.3 SAFETY CONSIDERATIONS

### DANGER

**EXPLOSION HAZARD.** Possible explosion hazard if the REANIBEX 100 is used in the presence of mixtures with concentrations of oxygen over 25% or flammable anaesthetic products.

### WARNING

Incorrect use of the equipment may cause injury. Follow the instructions in the User Guide for correct use.

### WARNING

Avoid touching the pads when these are placed on the patient, as this may affect safety and results.

### WARNING

Prevent conductive parts of pads and connectors associated with applied parts, from coming into contact with other conductive parts, including the earth.

### WARNING

**SHOCK OR FIRE HAZARD.** The defibrillator can deliver up to 200 Joules of energy. If the equipment is not used correctly, as described in these instructions for use, this energy may cause severe injuries or death. Ensure that you are familiar with how to use the equipment before using it.

### WARNING

**SHOCK OR FIRE HAZARD.** Do not disassemble the defibrillator. This equipment contains dangerous

high voltage. For repairs, please contact authorised technical service staff.

## WARNING

### SHOCK OR FIRE HAZARD

- Never use the REANIBEX 100 over stagnant water. Do not submerge the equipment or any part of it in water or any other liquid. Do not spill liquid on the equipment or any of its accessories. If the equipment gets wet, dry it with a towel.
- Do not clean the equipment with flammable agents such as acetones.
- Do not sterilise the equipment in an autoclave or by any other means.

## WARNING

### DANGEROUS ELECTRIC SHOCK HAZARD

- The defibrillator may deliver up to 200 Joules of energy during discharge. When the electricity is being discharged, do not touch the patient or the defibrillation pads.
- During defibrillation, prevent patient body parts (uncovered skin of the head and limbs) from coming into contact with conductive liquid such as gel, blood or serum and/or metal objects such as the stretcher, which may give rise to undesirable pathways for the defibrillation current.
- Ensure that no one touches the patient, the bed or any conductive material in contact with the patient during defibrillation. The defibrillation current may be partially discharged through the person, causing injury to the user and people near the unit.

## WARNING

- The air cavities formed between the defibrillation pads and the skin of the patient can cause burns during defibrillation. Ensure that the defibrillation pads are perfectly adhered to the patient's skin. Once adhered, if the position of the pads needs to be changed, remove the pads and replace them with new ones.
- Do not allow the defibrillation pads to touch each other or to touch any conducting material during defibrillation. This contact can generate an electrical arc and cause burns on the patient's skin, which could, in turn, divert the current away from the heart.

## WARNING

- Carefully follow the instructions indicated on the labels of the defibrillation pads.
- The defibrillation pads must be used before the expiry date indicated on their labels. If the pads are dried out or damaged, they can generate electrical arcs and burns during their use.
- Do not open the defibrillation pad packaging until just prior to use.
- Do not reuse the defibrillation pads. Dispose of all defibrillation pads after use.

## WARNING

A delay in delivering the shock can involve a spontaneous change from a rhythm analysed as shockable to a rhythm that is not shockable, giving rise to inadequate shock delivery.

## WARNING

### POSSIBLE ELECTRICAL INTERFERENCE

- The presence of radio frequency (RF) sources near the REANIBEX 100 can cause incorrect operation of the equipment. The electromagnetic compatibility of adjacent equipment must be verified before

using the REANIBEX 100.

- The use of cables, pads or accessories not specified in this manual for use with the REANIBEX 100 can cause an increase in emissions or lower immunity versus electromagnetic or radio interferences. These interferences can affect operation of the defibrillator or of equipment in the immediate surroundings.
- The REANIBEX 100 and its accessories may be sensitive to interferences from other sources of emissions.
- The REANIBEX 100 must be installed and started up according to the information dealing with Electromagnetic Compatibility (EMC) in Section “A.6 - Electromagnetic Compatibility Guide”.

## CAUTION

### POSSIBLE EQUIPMENT MALFUNCTION

- The use of pads or batteries from other manufacturers may affect proper operation of the equipment and invalidate the safety certification. Use only the accessories specified in this User Manual.
- Using the REANIBEX 100 or its accessories in environmental conditions other than those specified in this manual may affect proper operation of the equipment or the accessories. Before using the REANIBEX 100, make sure the equipment is stabilised at the operating temperature range.

## WARNING

**POSSIBLE EQUIPMENT MALFUNCTION.** Changing the configuration of the equipment from factory default values will affect the operation of the equipment. Changes of the default configuration must be performed only by authorised personnel.

## CAUTION

### POSSIBLE DAMAGE TO THE EQUIPMENT

- The equipment can be damaged by mechanical or physical maltreatment, such as immersion in water or by dropping from a height of more than 0.1 m.
- The components of the equipment may be damaged if the unit is located near sources of vibration.

## DANGER

**FIRE OR ELECTRICAL SHOCK HAZARD:** Make sure that the accessories and all the components are properly connected. Components or accessories that are not properly connected can cause fire or electrical shock.

## WARNING

The REANIBEX 100 does not have the capacity to reject the pulses of internal pacemakers in all cases. The equipment may detect pulses from internal pacemakers as QRS complexes and therefore the shock advice algorithm may provide an incorrect shock/no-shock decision.

## WARNING

The REANIBEX 100 has been designed for the treatment of cardiac arrest in adult and paediatric patients. To apply the therapy, the correct patient type should be selected.

## DANGER

**HAZARD OF EXPLOSION.** Do not attempt to open or handle the battery. Do not incinerate the battery.

Avoid electrical contact between the battery terminals.

### WARNING

- Follow the local, regional or national regulations in your country for the disposal of worn batteries.
- Do not expose batteries to temperatures above 50 °C for long periods of time as this reduces battery life.
- Keep batteries away from flames and other heat sources.
- Do not use the batteries in environments with high humidity. Make sure that the batteries do not get wet.
- Do not crush, strike, dent or deform the batteries.

### WARNING

Place the disposable defibrillation pads as indicated in the pads packaging.

### WARNING

To guarantee patient safety, do not place the REANIBEX 100 in a position from where it could fall on the patient.

### WARNING

Periodic checks should be performed to ensure that the REANIBEX 100 and its accessories are operating properly. Follow the recommendations described in the MAINTENANCE section of this manual.

### WARNING

Do not remove the battery from the equipment while working with a patient, as this will switch off the equipment.

### WARNING

Keep the REANIBEX 100 and its accessories out of the reach of children and domestic animals.

### WARNING

Keep the REANIBEX 100 away from sources of heat or flames.

### WARNING

The temperature of some parts of the equipment, as well as the temperature of the applied parts exceeded the limits indicated by the standard EN 60601-1 (43°C). The contact time can exceed 10 minutes. During the tests, working at an ambient temperature of 50°C, the measured maximum temperature of the applied parts was 51.9°C.

This is reasonable considering that the equipment can be used at an ambient temperature of up to 50°C, so the maximum temperature of the applied part must be extrapolated taking this value into account. The damage caused to the patient due to the temperature of those applied part is not considered serious.

### 1.4 ADDITIONAL INFORMATION REQUEST

Read this user manual carefully. If needed, contact Bexen cardio or a manufacturer's authorized distributor to obtain assistance in setting up, using or maintaining the REANIBEX 100, or to report adverse events.

## 2 DESCRIPTION OF THE EQUIPMENT

This section provides general information on the use of the REANIBEX 100 and explains controls and indicators.

Certain functionalities or options that are described in this section may not be included in your REANIBEX 100, depending on the configuration of the equipment.

### 2.1 BASIC ORIENTATION

This section provides basic guidelines regarding the REANIBEX 100 equipment, its controls, indicators and connectors.

#### 2.1.1 INDICATORS AND CONTROLS

The following illustrations show the front view of the equipment, showing the operating controls and indicators:



Figure 1: Front View with the cover opened

## 2 DESCRIPTION OF THE EQUIPMENT

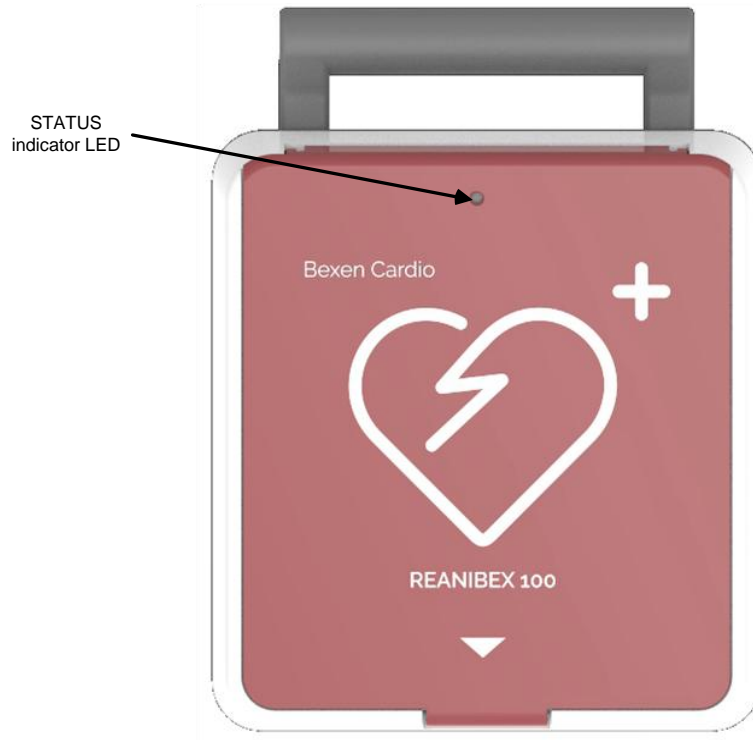





Figure 2: Front View with the cover closed

CONTROL	DESCRIPTION
	<b>ON/OFF BUTTON.</b> The equipment is automatically switched on when the lid is opened. Additionally, this button can be used to switch the equipment on and off. When the equipment is on, this button is illuminated with a green LED.
	<b>PAEDIATRIC MODE BUTTON:</b> This button is used to select the paediatric mode. When the selected patient type is PAEDIATRIC, the button is illuminated with a green LED. For patients under 8 years of age or weighing less than 25 kg (55 lbs) the paediatric mode should be selected
	<b>SHOCK BUTTON.</b> In semi-automatic mode, this button should be pressed to deliver a defibrillation shock. This button flashes when the defibrillator is ready to deliver the shock.
	<b>STATUS INDICATOR LED.</b> In standby mode, this LED, visible through the REANIBEX 100 cover, indicates the general status of the REANIBEX 100. When the device is ready to be used with a patient, the LED will flash every 10 seconds. If any problem is detected, the status indicator LED will be off and depending on the detected condition, a voice message or two beeps will be issued periodically.

### 2.1.2 CONNECTORS

On the bottom left corner of the REANIBEX 100 device there are two connectors:

- The pads connector, that is used to connect the defibrillation pads when the REANIBEX 100 device is used to treat a patient.

## 2 DESCRIPTION OF THE EQUIPMENT

- A USB-B connector that can be used to connect the REANIBEX 100 device to a PC to interchange information with the REANIBEX USB SYNC application.

A sliding lid allows selecting which connector is available, depending on the desired operating mode. The following illustration shows the connectors. Note how the sliding lid changes its position to give access to each of the connectors. The sliding lid in the top position gives access to the defibrillation pads connector (left), while the sliding lid in the bottom position gives access to the USB B connector

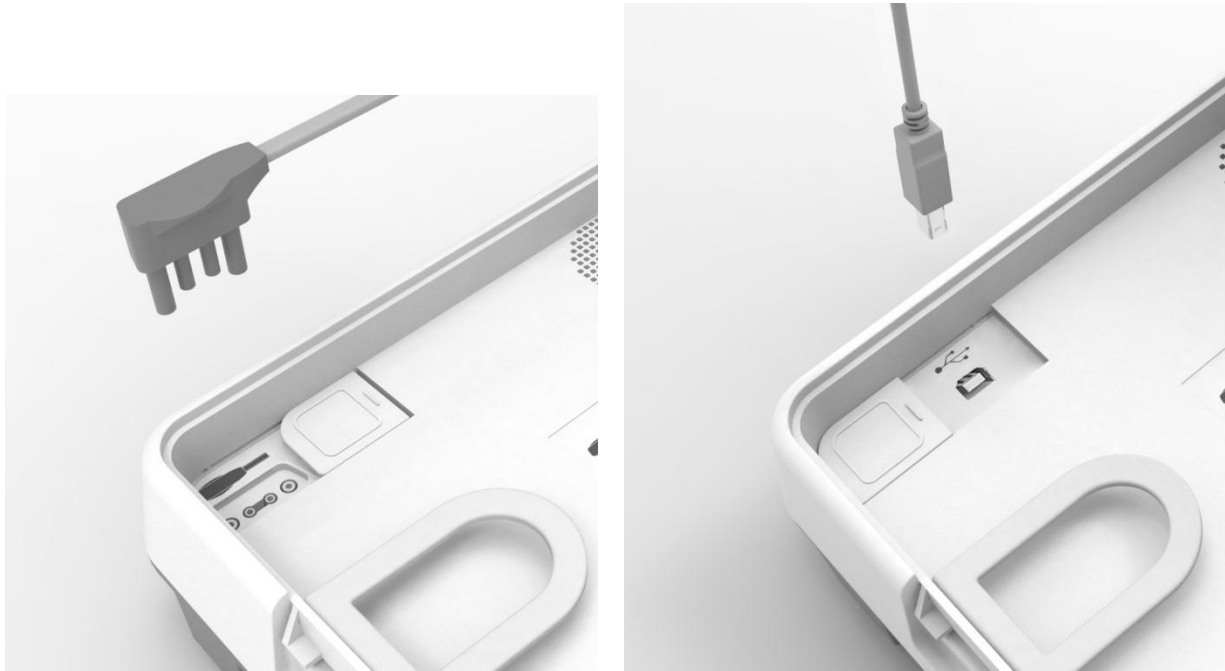

Figure 3: Pads and USB connectors selectable by a sliding lid.

### 2.2 BATTERIES

The REANIBEX 100 is battery-powered. When the battery is low, if the device is switched off the status indicator LED will be off, and if the device is on a periodic voice message will be issued.

The auxiliary mobile application, REANIBEX NFC READER allows checking the battery capacity in percentage. For that purpose, open the mobile application in a mobile phone, connect the mobile phone to the REANIBEX 100 device through NFC and check the information regarding battery capacity in the Information section.

If the battery is not installed in the equipment, the equipment cannot be switched on and the status indicator LED will be off.

#### **WARNING**

Check the status indicator LED periodically and make sure the REANIBEX 100 device is always connected to a sufficiently charged battery.

## 2 DESCRIPTION OF THE EQUIPMENT

The REANIBEX 100 uses high-capacity batteries that require minimum maintenance. For further information, please refer to Section “7.5 BATTERY MAINTENANCE”.

### BATTERY CAPACITY

A new, fully charged LiMnO<sub>2</sub> battery working at 20°C delivers more than 300 shocks at 200 Joules and more than 36 hours of ECG monitoring.

### 2.2.1 BATTERY DURATION

Battery life depends on how the battery is used and how frequently it is used. When used and maintained correctly, the useful life of the battery is 5 years.

### AUTO POWER-OFF

To optimize the use of the battery, the equipment will automatically power-off after 10 minutes in the following conditions:

- There is no patient connected, and
- No button is pressed.

#### CAUTION

Only use batteries supplied by BEXEN CARDIO or its authorised distributors. Using another type of battery may mean that the device does not operate correctly.

#### WARNING

Follow the local, regional or national regulations in your country to recycle the REANIBEX 100 batteries or send them to BEXEN CARDIO.

#### WARNING

Storing batteries at temperatures over **30°C** significantly reduces battery life.

#### WARNING

##### EXPLOSION HAZARD

- Do not attempt to open or handle the battery.
- Do not incinerate the battery.
- Avoid electrical contact between the battery terminals.
- Do not attempt to recharge the batteries, they could explode.

### 2.3 PADS

The REANIBEX 100 uses disposable pads for defibrillation. The references of the pads approved by the manufacturer are listed in section “**A.8 ACCESORIES, CONSUMABLES AND COMPLEMENTARY TOOLS**”.

### 3 INSTALLATION OF THE EQUIPMENT

Before using the REANIBEX 100, make sure that the equipment is ready for use by performing the following checks:

- Ensure the unit is in perfect working condition. Check that the device, its accessories and cables show no signs of damage and that they are in good condition.
- Check that the battery is inserted and properly connected. For that purpose, refer to section **3.2 INSTALLING THE BATTERY**.

#### CAUTION

Only use batteries supplied by BEXEN CARDIO, or its authorised distributors. Using another type of battery can impair proper equipment operation.

- Check that the defibrillation pads are in perfect storage conditions, connected to the device (refer to section **3.1 CONNECTING THE PADS** ) and check their expiration date.

#### CAUTION

- Carefully follow the instructions indicated on the labels of the defibrillation pads.
- The defibrillation pads must be used before the expiration date indicated on their labels. If the pads are dry or damaged, they can generate electrical arcs and burns during their use.
- Discard the defibrillation pads once they have been used.

- Check that the status green LED at the top of the equipment is flashing periodically when the equipment is off (stand-by mode) which means that the equipment is ready to be used with a patient. Refer to section “**2.1.1 INDICATORS AND CONTROLS**” for information on how to locate the status indicator LED, if needed. If the status indicator LED does not flash periodically, refer to section “**8 TROUBLESHOOTING**”.
- It is recommended to keep the following parts easily accessible:
  - A spare battery in proper conditions of maintenance.
  - Spare defibrillation pads.
  - Accessories to clean and shave, if necessary, the areas where the pads will be placed on the patient.

#### 3.1 CONNECTING THE PADS

The REANIBEX 100 equipment can be used to provide therapy by means of disposable pads for both adult and paediatric patients.

Usually the pads will be pre-connected to the REANIBEX 100 device. If that is not the case, connect the pads cable to the connector of the REANIBEX 100 as shown in the following figure:

## 3 INSTALLATION OF THE EQUIPMENT

1. Align the disposable pads connector with the connector input.
2. Push in firmly until the connector is in place.

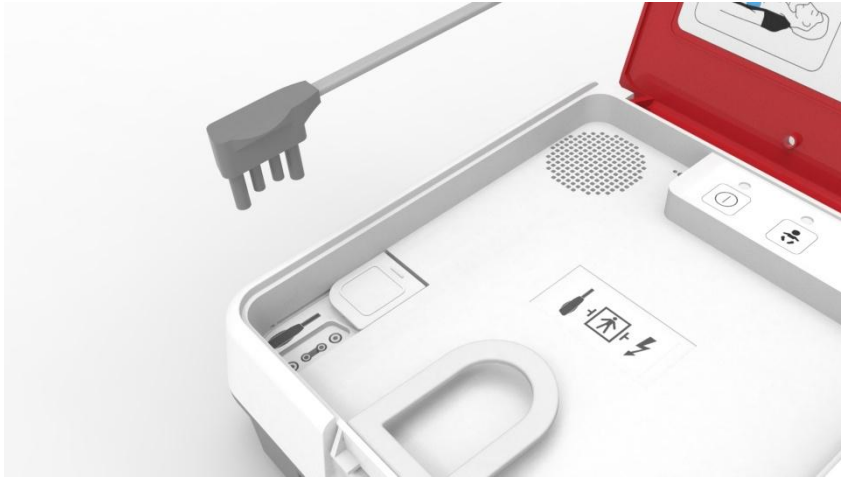

Figure 4: Therapy cable connection

### 3.2 INSTALLING THE BATTERY

The REANIBEX 100 can run on a battery. To install the battery:

1. Open the battery compartment on the back part of the device.
2. Connect the battery connector. Make sure that you hear a click.
3. Place the battery on the battery compartment, as shown in **Figure 5**.
4. Close the battery compartment.

### 3 INSTALLATION OF THE EQUIPMENT

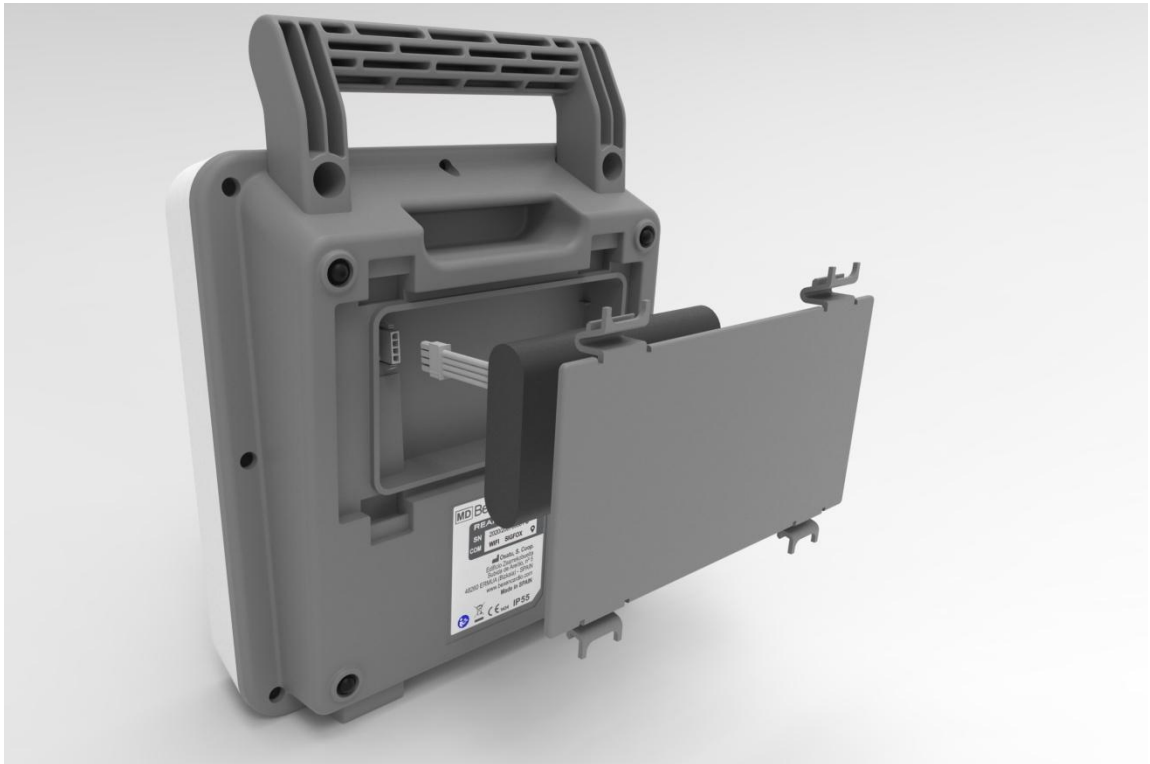

**Figure 5: Battery installation**

To remove the battery, unlock the battery connector.

#### **CAUTION**

The replacement of lithium batteries by inadequately trained personnel could result in a HAZARD. Carefully read these instructions before attempting to replace the REANIBEX 100 batteries.

### 4 AUTOMATIC EXTERNAL DEFIBRILLATION

#### 4.1 INTENDED USE

This section describes the basic functions of the REANIBEX 100 when it is working in Automatic Defibrillator (AED) mode, as well as the messages that are issued during equipment operation to guide the user.

In AED mode, the equipment analyses the patient's ECG signal and guides the user through the operation based on the rhythm detected by means of audible messages. If the equipment detects a shockable rhythm, the energy will be charged automatically.

The Automatic Defibrillator mode is intended to be used by laypeople with the following aptitudes and training, or that has been authorized by a competent body:

- Basic knowledge of cardiopulmonary resuscitation (CPR).
- Basic knowledge on REANIBEX 100 usage.

Defibrillation is only one of the aspects of medical care needed to resuscitate a patient with a shockable ECG rhythm. Other support measures such as the following may be required, depending on the situation:

- Cardio-Pulmonary Resuscitation (CPR).
- Administration of supplementary oxygen.
- Pharmacological treatment.

#### INDICATIONS FOR USE

The Automatic Defibrillator (AED) mode is indicated for use in patients who undergo cardio-pulmonary arrest (AED) and have the following symptoms:

- The patient is unconscious (not responding)
- The patient does not breath spontaneously

#### CONTRAINDICATIONS

Not known.

#### 4.2 WARNINGS AND PRECAUTIONS

##### WARNING

##### DANGER OF BURNS, FIRE AND INEFFECTIVE ENERGY ADMINISTRATION

- The air cavities formed between the defibrillation pads and the skin of the patient can cause burns during defibrillation. Ensure that the defibrillation pads are perfectly adhered to the patient's skin. Once adhered, if the position of the pads needs to be changed, remove the pads and replace them with new ones.

## 4 AUTOMATIC EXTERNAL DEFIBRILLATION

- Do not allow disposable pads to touch one another or come into contact with lead wires, dressings, etc. These contacts may give rise to electrical arcs, causing burns to the patient's skin and deviating part of the defibrillation energy.
- Dry or damaged pads can cause an electrical arc during the discharge causing burns on the skin of the patient.

### WARNING

The REANIBEX 100 should never be used on patients that are conscious, responding or breathing spontaneously.

### WARNING

#### POSSIBLE MISINTERPRETATION OF THE ECG

- Do not perform the analysis inside moving vehicles. The interferences caused by the movement of the vehicle can generate incorrect diagnoses. Detection of movement can also delay the analysis.

### WARNING

The sensitivity in the detection of shockable arrhythmias could be reduced in patients with implantable pacemakers.

### WARNING

The presence of radio frequency (RF) sources near the equipment can cause incorrect operation of the equipment.

### WARNING

Defibrillation pads may cause contact injuries or allergic reactions on some patients. Follow the instructions for use of the pads and avoid exceeding the recommended contact time.

### 4.3 PREPARING FOR AUTOMATIC EXTERNAL DEFIBRILLATION

Take the following steps before performing Automatic Defibrillation:

1. Verify that the patient has undergone cardio-respiratory arrest, meaning that the patient presents the following symptoms:
  - The patient does not respond (unconscious)
  - The patient does not breathe spontaneously
2. If possible, place the patient on a hard surface, away from water or any conductive material.
3. Prepare the patient's skin for the application of the pads:
  - Remove all clothes from the patient's chest.
  - If necessary, remove the hair from the patient's chest. Avoid scratching or cutting the patient's skin. Avoid placing the pads on broken skin.
  - If possible, clean the patient's skin. Remove any drug patches or ointments from the patient's skin.

## 4 AUTOMATIC EXTERNAL DEFIBRILLATION

- Never use pure alcohol or ether to clean the patient's skin as these may increase the skin's resistance.
  - If needed, dry the patient's skin energetically with a towel or gauze, in order to remove oil and skin cells and improve pads adherence.
4. Ensure that the defibrillation pads are not expired and that the pads packaging is intact.
  5. Place the pads on the patient's chest following the instructions in the pads packaging. Apply the pads firmly to the bare chest in the antero-lateral position, one pad placed below the right clavicle and the other in the left axilla. In paediatric patients, if the pads are too large for the size of the patient and there is a danger or charge arcing across the pads, one should be placed on the upper back, below the left scapula, and the other on the front, to the left of the sternum. This is known as the antero-posterior position.

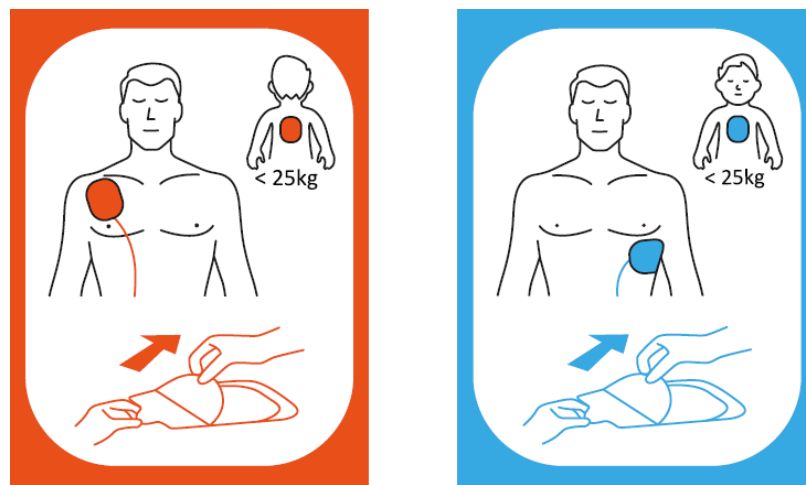

Figure 6: Placing the pads

Bear in mind the following special considerations when placing the pads:

- **Paediatric patients.** For patients less than 8 years of age or weighing less than 25 kg (55 lbs) ensure that the equipment is configured in paediatric mode.
  - **Obese patients or patients with large breasts.** Place the pads on the flat surface of the torso. If the skin folds or the breast tissue impedes proper adherence, it may be necessary to stretch the folds of the skin to obtain a flat surface.
  - **Thin patients.** Press the pads onto the surface of the torso, following the contour of the ribs to prevent air bubbles.
  - **Patients with pacemakers.** Place the defibrillation pads at least 10 cm from the generator and follow the same protocol as for any patient with cardiac arrest.
  - **Patients with implanted defibrillators.** Place the defibrillation pads at least 12-15 cm from the generator and follow the same protocol as for any patient with cardiac arrest.
6. Connect the pads cable to the REANIBEX 100 if it has not been connected previously, as described in Section “3.1 CONNECTING THE PADS”.

### WARNING

#### RISK OF STRANGULATION

Carefully route the defibrillation pads to reduce the possibility of patient entanglement or strangulation.

### 4.4 AUTOMATIC EXTERNAL DEFIBRILLATION PROCEDURE

After preparing the patient's skin, take the following steps to use the equipment:

1. **Switching on the equipment.** The REANIBEX 100 is automatically switched on when its cover is opened. If it doesn't automatically switch on, use the ON/OFF button to switch it on.
2. **Select patient type.** The REANIBEX 100 will issue a voice message to indicate the selected patient mode (adult/paediatric). If the mode is not adequate, change it by pressing the paediatric mode button. When the selected patient mode is paediatric, the LED above the paediatric mode button will be ON.
3. **Connect the pads.** After being switched on, the REANIBEX 100 will check that the pads are properly connected. If the pads are not properly connected to the patient, one of the following messages will be emitted: "**APPLY PADS EXACTLY AS SHOWN IN PICTURE**" or "**CHECK PADS FOR GOOD CONTACT**".
4. **Follow the voice prompt instructions.** After connecting the pads properly, the REANIBEX 100 will start analysing the ECG signal, while emitting the following voice prompt "**DO NOT TOUCH PATIENT**".

During signal analysis, the equipment will emit the following voice prompt: "**ANALYZING HEART RHYTHM**".

### WARNING

#### POSSIBLE MISINTERPRETATION OF THE ECG

Do not move the equipment during the analysis. Moving the equipment may generate incorrect diagnoses. Do not touch the patient or the equipment during the analysis.

Two situations can occur after the analysis is completed:

#### SHOCK NOT ADVISED

The equipment detects a patient rhythm that does not require defibrillation and emits the following message "**NO SHOCK ADVISED**". The shock button will remain disabled since it is not necessary to deliver the shock.

The equipment will then guide the rescuer to perform Cardio-Pulmonary Resuscitation (CPR) and emit the following message: "**BEGIN CARDIOPULMONARY RESUSCITATION**". During this time lapse, which can be configured, ECG signal analysis is not performed. In addition, a metronome will sound to assist the application of compression rates and ventilation on the patient at the appropriate frequency and ratio.

After the CPR time has elapsed, the equipment will automatically start a new analysis.

#### SHOCK ADVISED

## 4 AUTOMATIC EXTERNAL DEFIBRILLATION

The equipment detects a patient rhythm that requires defibrillation and emits the following message “**SHOCK ADVISED**”. Once the equipment detects a patient rhythm that requires defibrillation, rhythm analysis is stopped. The REANIBEX 100 automatically charges the energy. The patient’s ECG signal is not analyzed during the energy charge and while the equipment is prepared to deliver the shock. After the equipment has finished charging the energy, it is ready to deliver the shock.

**Shock delivery in semi-automatic mode.** If the REANIBEX 100 is semi-automatic, the shock button will flash and the following voice messages will be issued “**DO NOT TOUCH PATIENT**”, “**PRESS FLASHING BUTTON TO DELIVER SHOCK**”. Before delivering the shock, make sure that nobody touches the patient, the bed or the equipment and that nothing



is connected to the patient. To deliver the shock, press the shock button

If the shock is not delivered in less than 15 seconds, the message “**NO SHOCK DELIVERED**” will be issued.

**Shock delivery in fully-automatic mode.** If the REANIBEX 100 is fully-automatic, the shock button will flash to alert the user that a shock is advised, and the following voice messages will be issued “**DO NOT TOUCH PATIENT**”, “**CHARGING**”. Make sure that nobody touches the patient, the bed or the equipment and that nothing is connected to the patient. The shock will be automatically delivered.

Depending on the configuration of the equipment (number of consecutive shocks), a new analysis cycle may start after the REANIBEX 100 delivers the shock. This will occur until the number of shocks established in the “Consecutive Shocks” parameter is delivered. However, if the number of consecutive shocks has been set to 1, the equipment will enter into CPR time.

### 4.5 TROUBLESHOOTING

If the REANIBEX 100 does not work as expected during patient operation mode, refer to Section “**8.2 AUTOMATIC DEFIBRILLATION PROBLEMS**”.

## 5 CONFIGURATION

### 5.1 ACCESSORIES TO CONFIGURE THE DEVICE

The REANIBEX 100 can be configured through the PC application REANIBEX USB SYNC for data synchronization using the USB port.

To prevent unauthorised changes to the configuration of the equipment, the access to these applications is password protected.

For safety reasons, not all configurable parameters can be edited using this application. To change configuration parameters not editable through the application, contact your authorized distributor or Technical Service personnel.

### 5.2 CONFIGURABLE PARAMETERS

Described below are all the parameters that can be configured in the REANIBEX 100, a description of the parameter, the various options available for each parameter and the default setting (shown in brackets).

#### 5.2.1 AED CONFIGURATION

These parameters are used to configure operation of the equipment..

The following parameters can be changed by the authorized distributor or Technical Service personnel:

PARAMETER	DESCRIPTION	OPTIONS
CPR Time 1	This is used to establish the cardio-pulmonary resuscitation time to apply after applying the number of shocks indicated by the CONSECUTIVE SHOCKS parameter.	60, (120), 150 and 180 seconds
CPR Time 2	This is used to establish the cardio-pulmonary resuscitation time to apply after the equipment displays the warning: "SHOCK NOT RECOMMENDED".	60, (120), 150 and 180 seconds
Messages	This is used to establish the level of detail provided by the voice prompt emitted when CPR 1 time is going to begin: Short: The equipment simplifies the message provided during the operation Long: The equipment provides detailed information on step to be taken during operation	(Short), long
Consecutive shocks	This defines the maximum number of consecutive shocks that can be delivered to the patient before the pause established by CPR 1 Time.	(1), 2, 3 and 4 shocks
Adult shock energy 1	The first level of the energy protocol for adult patients	150 J, 175 J, (200 J)
Adult shock energy 2	The second level of the energy protocol for adult patients for adult	150 J, 175 J, (200 J)
Adult shock energy 3	The third level of the energy protocol	150 J, 175 J, (200 J)

Paediatric energy 1	shock	The first level of the energy protocol for paediatric patients	(50 J), 65 J, 75 J, 90 J
Paediatric energy 2	shock	The second level of the energy protocol for paediatric patients	50 J, 65 J, (75 J), 90 J
Paediatric energy 3	shock	The third level of the energy protocol for paediatric patients	50 J, 65 J, 75 J, (90 J)
Metronome Rate		Can be used to determine rate for the metronome in compressions per minute	(100), 110, 120 cpm
CPR Ratio Adults		This establishes the ratio between compressions and respirations during CPR for adults	(30:2), 15:2, Only compressions
CPR Ratio Paediatric		This establishes the ratio between compressions and respirations during CPR for paediatrics	30:2, (15:2), Only compressions
Default patient mode	switch-on	This establishes the default patient mode when the device is switched-on	(Adult) / Paediatric
Language		This establishes the language used for the voice prompts.	Different languages available

### WARNING

#### POSSIBLE INCORRECT OPERATION OF THE EQUIPMENT

Changing the configuration of the equipment to factory default values will affect the operation of the equipment. Changes to the default configuration must be performed by authorised personnel only.

### 5.3 TESTS

The Test mode can be used to force the equipment to perform manual tests in order to check equipment integrity.

When switched on and during operation with patient, the equipment performs various automatic tests and checks to ensure that all the parts of the equipment are working properly. Additionally, when the equipment is switched off and equipped with a battery, it performs daily and monthly Self Tests.

Manual tests are a complement to the checks performed by the equipment automatically.

### WARNING

Make sure that the REANIBEX 100 is not connected to a patient when tests are performed in the Test mode.

#### 5.3.1 TEST MODE

This option is used to perform a series of verifications and checks on various equipment components: system control circuits, battery and battery status, patient monitoring circuits, defibrillation pulse delivery, etc.

The result of the tests is indicated by a voice message after the tests have been performed. Additionally, the mobile application REANIBEX NFC READER can be used to obtain additional information about the

test results. If an error occurs, the error code will be displayed in the application. This consists of an E- and a numerical code. If the results of the tests are correct, "OK" will appear on the application.

Take the following steps to perform a Hardware Test:

1. Open the REANIBEX 100 cover.
2. If it has automatically switched on, switch it off by using the ON/OFF button.
3. When the device is in stand-by mode, press the paediatric mode button while switching on the equipment with the ON/OFF button.
4. A hardware test will be performed. After finishing the test, a voice message will be issued to describe the result of the test: "DEVICE READY" if the result of the test is OK or "CALL TECHNICAL SERVICE" if any error was detected. In that case, please contact the Authorised Technical Service.

If there is any issue with the defibrillation pads (pads not connected, expired or used) the REANIBEX 100 will indicate this condition and will wait 10 seconds for the user to solve this problem before continuing with the manual test,

5. The mobile application REANIBEX NFC READER can be used to obtain more information regarding the obtained error.

**NOTE:** It is recommended not to perform this Manual test more than 5 consecutive times to prevent the internal components of the equipment from undergoing excessive temperatures.

### 5.3.2 SELF- TESTS

The automatic tests performed by the REANIBEX 100 will only take place between the pre-set time for the Self Test and the following hour, as well as in ambient temperature conditions of between 0 and 50°C.

A Self Test will not be performed if:

- The equipment is in operation.
- The equipment is performing a Self Test and the ON button is pressed. In this case, the Self Test will be interrupted and normal operation will proceed.
- The ambient temperature is outside the established range.
- The battery is not installed in the equipment.

If a Self Test cannot be performed for the reasons indicated above, it will be attempted again if:

- It is in the time period established for Self Tests.
- No other Self Test has been completed within the time period of the current day.
- The equipment is switched off for at least 2 hours.

The results of the Self Tests will be stored in the memory. If a Self Test cannot be performed, the reason why the test was skipped will be saved in the memory.

There are several types of Self Tests:

- A daily Self Test performed every day during the established time period.
- A monthly Self Test carried out once a month that includes the daily Self Tests.

## 6 DATA MANAGEMENT

### 6.1 DESCRIPTION

The REANIBEX 100 can store in its internal memory 10 different complete episodes.

An episode consists of the continuous ECG signal and its associated events (energy discharge, analysis, etc.) from the time the equipment is switched on until the equipment is switched off or until the battery is depleted.

All the information registered in the internal memory of the equipment can be reviewed afterwards in the Web Monitoring Application REANIBEX DATA NET.

In order to avoid any loss of information, it is recommendable to download the data stored in the unit periodically (by using REANIBEX USB Sync).

### 6.2 STORED EVENTS

All the events that are stored along with the ECG signal during registration of the intervention are shown below.

The texts in *cursive* are replaced with the appropriate value or option.

EVENT	DESCRIPTION
SWITCHING ON	Switching on the equipment
PATIENT: <i>patient</i>	Type of patient configured: Adult or paediatric
CONNECT PADS	The pads are not connected
CHECK THE PADS	The pads are connected to the equipment but their terminals are short-circuited
CHARGE: energy in JOULES	Charges a level of energy
SHOCK: energy in JOULES	Delivers a level of energy to the patient
SHOCK NOT DELIVERED	The shock has not been delivered to the patient
STARTING ANALYSIS	The analysis is starting
NO SHOCK ADVISED	The REANIBEX 100 has detected a rhythm that does not require a defibrillation shock
SHOCK ADVISED	The REANIBEX 100 has detected a rhythm that requires a defibrillation shock
START CPR TIME	The timer for the Cardio-Pulmonary Resuscitation time starts
ANALYSIS NOT POSSIBLE	The analysis cannot be performed

## 7 MAINTENANCE

### 7.1 OVERVIEW

Maintenance of the REANIBEX 100 and its accessories is essential to guarantee proper operation of the equipment. The expected service life of the REANIBEX 100 is 10 years.

If a failure is detected during any of the Self Tests performed by the equipment:

- **SERVICE MANDATORY** - The immediate intervention of Authorised Technical Service personnel is required. This type of failure affects elements that are critical for proper operation of the equipment. The equipment will go out of service.

When this type of failure is detected:

- the status indicator LED will be OFF.
- when the equipment is switched on, the message “CALL TECHNICAL SERVICE” will be issued.

### 7.2 MAINTENANCE ROUTINE

Although the REANIBEX 100 performs Self Tests when switched on, during operation and periodically when the equipment is powered or switched off, this does not replace the need to perform regular maintenance on the equipment to ensure that all its parts function properly. Regular routine maintenance is recommended to complement the Self Tests performed by the equipment.

The following steps are recommended to inspect the equipment and the accessories:

- Make sure that the REANIBEX 100 is clean and that neither the equipment nor its accessories are visibly damaged.
- Make sure that the connectors and pads are not damaged or cracked and that the cables are not broken. Ensure that the connections are safe. Check that the defibrillation pads have not expired and that there is a sufficient amount of them available.
- Check that the battery is charged.
- After each use, ensure that all the necessary supplies, accessories and spare parts are available for the next use.
- With the cover closed, make sure that the status indicator LED flashed every 10 seconds. If not, open the cover and check if the pads are correct. Perform a Manual test to check the equipment status (Refer to section 5.3.1 Manual Test).

#### 7.2.1 CHECK LIST

A list of checks and verifications that are recommended to ensure proper operation of the equipment is shown below. It is recommended to check the REANIBEX 100, its accessories and fungibles after each use.

<b>SERIAL NUMBER:</b>		<b>DATE:</b>	
<b>OPERATOR:</b>		<b>SIGNATURE:</b>	

OPERATION	ACTION RECOMMENDED	RESULT
The equipment is dirty	Clean the equipment	
The equipment presents cracks or damage	Contact the Authorised Technical Service	
Damaged or broken connectors, cables	Replace the items that are damaged and contact the Authorised Technical Service	
Sufficient defibrillation pads present	None	
Defibrillation pads expired or open	Replace the defibrillation pads	
Battery damaged or leaking	Replace the battery	
Status indicator LED is NOT flashing	If an error appears the status indicator LED stops flashing- In this case, check the defibrillation pads and the battery, check that the equipment is not in training mode, perform a manual test and if needed contact the Authorised Technical Service	

### 7.3 CLEANING INSTRUCTIONS

Clean the REANIBEX 100 after it has been used to treat a patient.

#### CAUTION

- The REANIBEX 100 and its accessories must not be sterilised or submerged in liquids unless stated otherwise in the instructions supplied with the accessories.
- Do not use abrasive cleaning agents or strong solvents such as bleach, bleach-based solvents, acetone or ketone-based cleaning agents.
- Do not use inflammable cleaning agents or mix disinfectants (such as bleach or ammonia), as this can generate hazardous gases.

#### CAUTION

**SHOCK OR FIRE HAZARD.** Before cleaning turn off the REANIBEX 100.

Take the following instructions into consideration when cleaning the REANIBEX 100:

- Use a slightly moist soft cloth. Do not use abrasive or inflammable cleaning products.
- Do not submerge the equipment in liquids and ensure that the cleaning fluids do not enter the equipment.
- Clean the equipment with the batteries installed to prevent the fluids from entering the battery contacts.
- Remove any remains adhered to the equipment before cleaning.
- Use only the following products:
  - Isopropyl or ethyl alcohol (dissolved to 70% in water)

- Quaternary ammonium compounds
- Hydrogen peroxide
- Soapy water

## 7.4 STORAGE

Follow the instructions below to store the equipment when the REANIBEX 100 is not in use:

- Store the REANIBEX 100 with the Li-MnO<sub>2</sub> batteries installed at a temperature between **0°C and 50°C**.
- Store the REANIBEX 100 without the batteries installed at a temperature between **-25°C and 70°C**.

## 7.5 BATTERY MAINTENANCE

Proper battery maintenance optimises battery performance and guarantees the accuracy of the battery charge indicated on the equipment.

Proper battery maintenance should include the following actions:

- Store the new battery packs at temperatures between **0°C and 50°C**. The ideal battery storage temperature is **25°C**.
- A brand new battery has a maximum service life of 5 years, regardless of whether it is installed on the equipment or not, if stored at the adequate temperature.
- When the battery is installed in the equipment, battery capacity is reduced due to several factors, and thus the frequency with which it must be replaced is variable:
  - Yearly battery self-discharge (3%)
  - Discharge due to periodical Self Tests (daily and monthly) performed in the equipment.
  - Discharge during the time the device is turned on.
  - Discharge due to information wirelessly sent by the equipment in units with optional communication capabilities.
- LiMnO<sub>2</sub> batteries must be recycled if they are visibly damaged or broken. Follow the local, regional or national regulations in your country for recycling.

### WARNING

**HAZARD OF EXPLOSION.** Do not attempt to open or handle the batteries. Do not incinerate the batteries. Do not puncture, crush, damage or disassemble the batteries. Do not apply reverse polarity to the batteries or expose them to high temperatures.

- When handling the batteries, be careful not to cause a short circuit in the terminals, as this could cause a fire.
- Possible danger of explosion, fire or harmful gases if Lithium batteries are attempted to be recharged.

### BATTERY CAPACITY

A new, fully charged LiMnO<sub>2</sub> battery working at 20°C provides more than 300 shocks at 200 Joules and approximately 36 hours of ECG monitoring.

The REANIBEX 100 starts giving a low battery level indicator when the remaining battery capacity is below 20%.

Once the low-battery alarm is issued, the device is capable of delivering at least three maximum energy (200 J) discharges.

### BATTERY LIFE

A brand new battery has a service life of 5 years (only for equipment without communication capabilities) if stored at the adequate temperature.

The service life of the battery for equipment with Sigfox and geolocation is 4 years (supposing that there is good coverage of Sigfox and geolocation in the place where the device is placed. During the daily tests the test result is sent and during the monthly test, the test result and the geolocation are sent).

Proper battery maintenance should include the following actions:

- Do not expose the batteries to high temperatures over 50°C for long periods of time.
- Do not attempt to recharge the battery.
- Do not allow electrical contact between the battery terminals.

If a battery is low or expired, replace it by a new battery as soon as possible.

## 7.6 SERVICE AND REPAIR

Bexen cardio shall only be held liable for aspects concerning the safety of the REANIBEX 100 if the maintenance, repairs and subsequent modifications have been carried out by technical personnel in Bexen cardio or authorised by Bexen cardio, and in cases where components that affected the safety of the equipment have been replaced with original spare parts (such as batteries and pads).

The company reserves the right to perform modifications without prior notice.

On request, Bexen cardio will provide circuit diagrams, lists of components, descriptions and other information to adequately assist the technical personnel that are qualified to repair the parts of the equipment that are designated as repairable by the manufacturer.

### WARNING

**HAZARD OF ELECTRICAL SHOCK HAZARD.** Do not open the REANIBEX 100, disassemble any of its parts or modify it in any way. The equipment must only be repaired by Authorised Technical Service personnel.

### 7.7 PRODUCT RECYCLING INFORMATION

Recycle the REANIBEX 100 at the end of its useful life.

The REANIBEX 100 must be cleaned and disinfected before recycling. The equipment, its accessories (disposable defibrillation pads and LiMnO<sub>2</sub> batteries) and equipment packaging must be recycled according to the recommendations of the local, regional or national authorities in each country.

If necessary, contact your local authorities to determine the proper method of disposal of parts and accessories of the REANIBEX 100.

#### **WARNING**

Follow the local, regional or national regulations in your country to recycle the various components of the REANIBEX 100 or send them to Bexen cardio.

### 7.8 WARRANTY

Consult the warranty statement provided with the REANIBEX 100.

If there is a fault in equipment operation due to supplies not recommended by Bexen cardio, this may invalidate the warranty.

#### **CAUTION**

Use only those accessories specified in this manual and recommended by Bexen cardio. The use of accessories, parts or supplies not recommended by Bexen cardio can cause incorrect operation and invalidate the safety and warranty certifications of the equipment.

### 7.9 ACCESSORIES, CONSUMABLES AND COMPLEMENTARY TOOLS

The list of all the accessories, consumables and complementary tools that can be used with the REANIBEX 100 is included in Section “**A.8 ACCESSORIES, CONSUMABLES AND COMPLEMENTARY TOOLS**”.

## 8 TROUBLESHOOTING

The REANIBEX 100 uses several methods to indicate that an error or problem has been detected. These are detected during the periodic Self Tests run by the equipment when the equipment is switched off, when it is switched on, during equipment operation or by user intervention.

The errors or problems are indicated by a switched off status indicator LED, by voice messages during operation and by the mobile application, REANIBEX NFC READER.

The following table lists the main problems that can occur in the equipment, the indication provided by the equipment, the possible cause and the measure required to solve the problem.

### WARNING

The product must only be repaired by Authorised Technical Service personnel.

### 8.1 GENERAL PROBLEMS

SYMPTOM	POSSIBLE CAUSE	POSSIBLE SOLUTION
The REANIBEX does not switch on	No power supply	• Insert a fully charged battery.
	An internal fuse has blown	• Contact the Authorised Technical Service
The unit goes off and does not switch on again	The battery is completely depleted	Replace the battery immediately
	The battery is disconnected	Check that the battery is correctly inserted
The status indicator LED is off when the equipment cover is closed.	The REANIBEX 100 has detected a condition requiring attention: the battery status is low, the pads have expired, used or not identified, or the equipment needs to be repaired	<ul style="list-style-type: none"> <li>• Use the mobile application or turn on the device to get more information regarding the error. If the battery or the pads need being replaced, replace them. If there is a error, contact the Authorised Technical Service</li> <li>• Obtain another defibrillator if necessary.</li> </ul>
	The REANIBEX 100 is in Training mode	• Use the mobile application to deactivate the Training mode.
One or more equipment buttons do not work	Possible fault in the equipment keypad	• Contact the Authorised Technical Service.
The unit does not connect to the mobile application REANIBEX NFC READER	The NFC application REANIBEX NFC READER is not open and waiting for data	• Check that the mobile application is open and waiting for data.

SYMPTOM	POSSIBLE CAUSE	POSSIBLE SOLUTION
	The phone's NFC adaptor is damaged	<ul style="list-style-type: none"> <li>• Check the mobile phone's NFC adaptor and replace it if necessary.</li> </ul>
	The phone's NFC adaptor does not meet the NFC standard	<ul style="list-style-type: none"> <li>• Make sure the phone's NFC adaptor is compatible with the NFC standard.</li> </ul>
	The REANIBEX 100's NFC antenna and the mobile phone's NFC adaptor are not close enough.	<ul style="list-style-type: none"> <li>• Align the REANIBEX 100's NFC adaptor up with that of the mobile phone. If required, try different positioning.</li> </ul>













### 8.2 AUTOMATIC DEFIBRILLATION PROBLEMS













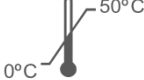

SYMPTOM	POSSIBLE CAUSE	POSSIBLE SOLUTION
One of the following messages can be heard: <b>"CHECK PADS FOR GOOD CONTACT "</b> or <b>"APPLY PADS EXACTLY AS SHOWN IN PICTURE "</b>	Pads not properly connected to the patient.	<ul style="list-style-type: none"> <li>• Exert pressure on the pads on the patient.</li> <li>• Clean, wash and dry the patient's skin.</li> </ul>
	Defective, expired or dried out pads.	<ul style="list-style-type: none"> <li>• Replace the pads.</li> </ul>
	Pads not properly connected to the equipment.	<ul style="list-style-type: none"> <li>• Exert pressure on the pads on the equipment connector.</li> </ul>
	Defective pads connector	<ul style="list-style-type: none"> <li>• Check the condition of the equipment.</li> </ul>
The following message can be heard: <b>"NO SHOCK DELIVERED"</b> .	The REANIBEX 100 has detected a shockable rhythm and has charged the energy. However, the shock button has not been pressed during the 15 seconds after completion of energy charge.	<ul style="list-style-type: none"> <li>• The next time the audible <b>"PRESS FLASHING BUTTON TO DELIVER SHOCK"</b> message appears after detecting a shockable rhythm and charging the energy, press the SHOCK button in the next 15 seconds (if the device is semi-Automated).</li> </ul>
	The disposable pads disconnect from the equipment or from the patient during energy charge or once the charge is completed.	<ul style="list-style-type: none"> <li>• Connect the disposable pads to the equipment and/or patient and wait until another analysis cycle is completed.</li> </ul>
The following message can be heard: <b>"CANNOT ANALYZE. STOP ALL MOTION"</b> .	The patient is moving.	<ul style="list-style-type: none"> <li>• Stop cardio-pulmonary resuscitation during the analysis.</li> </ul>
	Electrical or radio frequency interferences.	<ul style="list-style-type: none"> <li>• Use the REANIBEX 100 as far as possible from the equipment causing the interferences.</li> </ul>

SYMPTOM	POSSIBLE CAUSE	POSSIBLE SOLUTION
	Vehicle movement	<ul style="list-style-type: none"> <li>• Stop the vehicle while performing the analysis.</li> <li>• When possible, move the patient to a stable location.</li> </ul>
The message <b>“CALL TECHNICAL SERVICE”</b> is issued.	An error has been detected in the equipment operation.	<ul style="list-style-type: none"> <li>• Contact the Authorised Technical Service</li> </ul>

## A.1 SYMBOLS

This Annex provides information on the symbols used both in this manual and in the REANIBEX 100 equipment, its accessories and packaging.

SYMBOL	DESCRIPTION
	ON/OFF button on the front panel
	SHOCK button on the front panel
	PAEDIATRIC MODE button on the front panel
	Status indicator LED on the front panel (device in stand-by mode)
	BF Class Equipment/Component Protected against defibrillation
	Follow instructions for use
	Do not dispose of this product with non-differentiated urban waste. Dispose of the product according to local regulations. Electric and electronic equipment according to Article 11(2) of Directive 2002/96/EC on electric and electronic equipments.
<b>IP55</b>	Protection grade code versus dust/water entry as per IEC 60529 IP5X: Protected against dust IPX5: Protected against jets of water from any direction
<b>SN</b>	Equipment serial number
	Manufactured by
<b>CE</b> 1434	Symbol of conformity with applicable European Directives
	Medical device symbol
	NFC location
	Do not use if package is damaged
	Package shall not be opened until immediately prior to use

SYMBOL	DESCRIPTION
	Disposable battery
	Symbol of conformity with applicable European Directives
	Temperature range recommended for the use of LiMnO <sub>2</sub> batteries: 0°C to 50°C
	Do not attempt to open
	LiMnO <sub>2</sub> battery classified as Class 9 with UN transport certification
	Recyclable material Heavy metal substances. Dispose of these properly
	Do not expose to excessive heat or flames Do not incinerate
	Battery expiry date
	Fragile / Breakable Handle with care
	Protect from water
	Pressure range (altitude) recommended for storage: from 52.2 KPa to 106 KPa.
	Recommended storage temperature: -25°C to 70°C
	Relative humidity range recommended for storage: between 10% and 95%
	Recycle this item

## A.2 MESSAGES

This section describes the messages that can be issued during the operation of the device.

MESSAGE	DESCRIPTION
<b>MESSAGES WHILE USING THE EQUIPMENT WITH A PATIENT</b>	
The following messages can be issued while the device is being used to treat a cardiac arrest patient. The messages that are issued depend on the configuration of the equipment.	
STAY CALM	This message recommends the user to stay calm
FOLLOW VOICE INSTRUCTIONS	Prompts the user to follow the voice instructions issued by the device
CALL FOR HELP	Prompts the user to call the emergency medical services.
IF PATIENT IS UNRESPONSIVE AND NOT BREATHING NORMALLY, REMOVE CLOTHES FROM PATIENT'S CHEST	Instructs the user to remove the clothes from the patient's chest
PLUG IN PADS TO THE EQUIPMENT	The equipment has detected that the pads are not connected to the equipment.
APPLY PADS EXACTLY AS SHOWN IN PICTURE	The equipment has detected that the pads are not connected to the patient.
CHECK PADS FOR GOOD CONTACT	The equipment has detected that the pads are not properly adhered to the patient (impedance out of established limits).
REPLACE PADS	The equipment has detected that the connected pads are used, expired or not identified.
OPEN PADS PACKAGE. REMOVE PADS AND PLACE THE PADS ON PATIENT'S BARE CHEST, EXACTLY AS SHOWN IN PICTURE.	When the equipment is configured to issue long voice messages, it instructs the user how to place pads on the patient.
LOW BATTERY	The charge in the specified battery is below 20%
REPLACE BATTERY	The specified battery has discharged completely
GIVE COMPRESSIONS TO THE BEAT	Prompts the user to follow the rhythm indicated by the metronome to deliver chest compressions during CPR time
DO NOT TOUCH PATIENT	Prompts the user not to touch the patient because the ECG signal is going to be analysed or because a shock is going to be delivered
ANALYSING HEARTH RHYTHM	The patient's ECG signal is being analysed. Do not touch the patient
SHOCK ADVISED	A shockable rhythm has been detected after analysing the patient's ECG.
CHARGING	The equipment is charging the energy to deliver the shock.
PRESS FLASHING BUTTON TO DELIVER SHOCK	The equipment is ready to deliver the shock and waiting for the user to press the shock button.
NO SHOCK ADVISED	A non-shockable rhythm has been detected after analysing the patient's ECG.

MESSAGE	DESCRIPTION
IT IS SAFE TO TOUCH THE PATIENT. IF NEEDED, BEGIN CARDIOPULMONARY RESUSCITATION. GIVE COMPRESSIONS.	When the equipment is configured to issue long voice messages, it indicates the user that he/she can touch the patient safely to start the resuscitation.
PLACE THE BASE OF ONE HAND IN THE CENTER OF THE CHEST. PLACE YOUR OTHER HAND ON TOP OF THE FIRST. PUSH THE CHEST DOWN FIRMLY.	When the equipment is configured to issue long voice messages, it indicates the user how to place the hands to perform the compressions.
BEGIN CARDIOPULMONARY RESUSCITATION	Instructs the user to start CPR.
CONTINUE WITH COMPRESSIONS	Prompts the user to restart chest compressions after a pause to deliver ventilations.
STOP COMPRESSIONS	Instruct the user to interrupt chest compressions.
BREATH	Instructs the user to deliver artificial ventilation.
TILT HEAD BACK, PLACING ONE HAND ON THE FOREHEAD AND USING THE FINGERS OF THE OTHER HAND TO MOVE THE JAW UP AND FORWARD. PINCH NOSE AND GIVE TWO RESCUE BREATHS.	When the equipment is configured to issue long voice messages, it instructs the user in how to give rescue breaths
SHOCK DELIVERED	A shock has been delivered to the patient.
NO SHOCK DELIVERED	A shock has not been delivered to the patient.
CANNOT ANALYZE. STOP ALL MOTION	The ECG signal cannot be analysed.
ADULT MODE	The equipment is configured to treat adult patients
PAEDIATRIC MODE	The equipment is configured to treat paediatric patients
CALL TECHNICAL SERVICE	An error has been detected in equipment operation.
CLOSE THE COVER OF THE EQUIPMENT	The equipment detects that the cover is open
<b>TEST MODE MESSAGES</b>	
Messages that can be issued in the Test Mode of the device	
TEST MODE	The device is in TEST MODE to perform a manual test.
DISCONNECT FROM THE PATIENT	The device is in TEST MODE and detects that there is a patient connected to the equipment.
EQUIPMENT READY	The device is ready to be used
CALL TECHNICAL SERVICE	The device is not ready to be used because it has detected an error. This message prompts the user to contact technical service.
REPLACE BATTERY	This message indicates that the battery has expired or is very low and it should be replaced.
REPLACE PADS	This message indicates that the pads have expired or have already been used with a patient and they should be replaced.
TRANSMISSION IN PROGRESS	In equipment with optional communication capabilities, this indicates that the equipment is transmitting information to the monitoring web application.- REANIBEX DATA NET

<b>MESSAGE</b>	<b>DESCRIPTION</b>
TRANSMISSION COMPLETED	In equipment with optional communication capabilities, this indicates that the equipment finished the information transmission to the monitoring web application.
CONNECTION ERROR	In equipment with optional communication capabilities, this indicates that there was an error when trying to connect or to transmit to the monitoring web application.
UPDATE IN PROGRESS	This message indicates that the device is being updated (by USB).
NO UPGRADE PERFORMED	This message indicates that no device update has been performed (by USB).
TRAINING MODE	The device is configured in TRAINING MODE, not ready for being used with a patient.

## A.3 SPECIFICATIONS AND CHARACTERISTICS

### A.3 SPECIFICATIONS AND CHARACTERISTICS

#### TECHNICAL SPECIFICATIONS

<b>Safety Classification</b>	EN 60601-1:2006+ CORR:2010 + A11:2011 + A1:2013 + AC:2014 + A12:2014, BF type. Internally powered, Continuous operating mode.
------------------------------	---

#### DEFIBRILLATOR

<b>Waveform</b>	Biphasic truncated exponential with energy compensation depending on patient impedance.
<b>Output energy</b>	Adult: Selectable from 150 to 200 J $\pm$ 15% Paediatric: Selectable from 50 to 90 J $\pm$ 15%
<b>Energy Output Accuracy (over 50 <math>\Omega</math>)</b>	$\pm$ 15% in the entire range.
<b>Patient impedance range</b>	Minimum: 25 Ohm Maximum: 300 Ohm
<b>Pads options</b>	Disposable pre-connected universal pads valid for both adult and paediatric patients
<b>Voice prompts</b>	Audible messages that guide the user during the intervention.
<b>Charge Indication</b>	Shock button on the user interface flashing.
<b>Shock Control</b>	Front panel button with 3 LEDs
<b>Charging time</b>	0 seconds (the energy is pre-charged)
<b>Setting up the intervention parameters</b>	Use the options in the PC application REANIBEX USB SYNC
<b>Detection features</b>	VF sensitivity: Complies with AHA VT sensitivity: Complies with AHA NSR specificity Complies with AHA Specificity for other signals: Complies with AHA
<b>Maximum time from start of rhythm analysis to prepared for shock status.</b>	<ul style="list-style-type: none"> <li>- Less than 11 seconds with a new, fully charged LiMnO2 battery pack.</li> <li>- Less than 11 seconds with a new LiMnO2 battery pack, empty after delivering 15 shocks at 200 J and 25°C.</li> </ul>
<b>Maximum time from initial connection to power supply to prepared for shock.</b>	<ul style="list-style-type: none"> <li>- Less than 17 seconds with a new, fully charged LiMnO2 battery pack.</li> <li>- Less than 17 seconds with a new, fully charged LiMnO2 battery pack, empty after delivering 15 shocks at 200 J and 25°C.</li> </ul>
<b>Synchronisation</b>	If ventricular tachycardia is detected, the shock is automatically synchronised with the signal.

#### DATA STORAGE

<b>Memory Type</b>	Internal memory
--------------------	-----------------

## A.3 SPECIFICATIONS AND CHARACTERISTICS

<b>Capacity</b>	10 episodes of at least 15 hours
<b>Data</b>	Continuous ECG Significant events along with the associated ECG signal

### GENERAL

<b>Indicators</b>	Equipment ON indicator Status indicator LED Paediatric mode indicator SHOCK recommended indicator
-------------------	--

<b>Self Tests</b>	On Start up During operation Manuals on user request Automatic daily/monthly
-------------------	---

### POWER SUPPLY

#### Disposable battery

<b>Type</b>	LiMnO <sub>2</sub> 12 VCC (disposable)
<b>Capacity</b>	More than 300 shocks at 200 J and 20°C More than 36 hours monitoring of ECG.
<b>Self-live</b>	5 years (equipment without communications) 4 years (equipment with Sigfox + geolocation)* * see section 7.5 BATTERY MAINTENANCE for the conditions
<b>Weight</b>	250 grams

### ENVIRONMENTAL CONDITIONS

<b>Operating temperature</b>	0°C to 50°C with the LiMnO <sub>2</sub> battery pack installed
<b>Storage temperature</b>	-25°C to 70°C except disposable universal pads
<b>Relative humidity</b>	0 to 95%
<b>Atmospheric pressure (operation)</b>	0 to 5000 m (101,3 – 53,99 kPa)
<b>Solid/Water protection</b>	IP55 with the cover
<b>Vibration</b>	IEC 60601-1-11
<b>Shock</b>	IEC 60601-1-11
<b>Time required to warm from the minimum storage temperature between uses until the equipment is ready for intended use</b>	Less than 30 minutes
<b>Time required to cool from the maximum storage temperature between uses until the equipment is ready for intended use</b>	Less than 30 minutes

### PHYSICAL CHARACTERISTICS

### A.3 SPECIFICATIONS AND CHARACTERISTICS

**Weight**

Equipment without battery: 1,7 kg

Equipment with disposable pads and battery: 1,95 kg

LiMnO<sub>2</sub> battery: 217 g

**Dimensions**

96 mm height x 235 mm depth x 217 mm width (without handle)

96 mm height x 285 mm depth x 217 mm width (with handle)

**NOTE:** For further information, consult the Technical Manual of the REANIBEX 100.

## A.4 DEFIBRILLATION WAVE

For defibrillation, the REANIBEX 100 includes a BIPHASIC TRUNCATED EXPONENTIAL WAVEFORM:

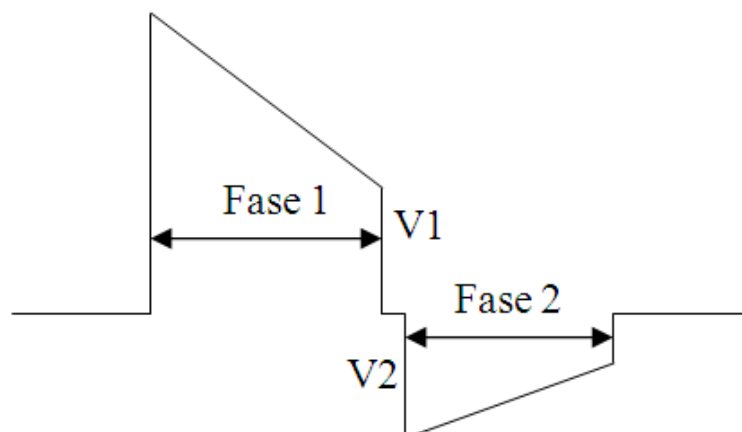

Figure 7: Defibrillation wave

The wave switchover time between Phase 1 and Phase 2 is 600  $\mu$ s. In addition, the negative voltage (V2) coincides with the positive voltage (V1) on change of polarity.

The energy supplied during both phases depends on patient impedance, which maximises defibrillation efficacy.

The equipment delivers shocks with impedances that vary between 25  $\Omega$  and 300  $\Omega$ . If impedance is less than 25  $\Omega$ , the equipment interprets that there is a short circuit in the defibrillation pads. In the event of impedances greater than 300  $\Omega$ , the equipment interprets that the pads are improperly connected to the patient or no patient is connected and issues the corresponding messages.

The energy supplied in each of the wave phases is adjusted dynamically according to patient impedance:

Load Impedance ( $\Omega$ )	Phase1 duration (msec)		Phase2 duration (msec)		Delivered energy (J)
	Min	Max	Min	Max	
25	5.1	6.0	3.4	4.0	197
50	6.8	7.9	4.5	5.3	198
75	7.6	9.4	4.9	6.5	201
100	8.7	10.6	5.8	7.1	203
125	9.5	11.2	6.3	7.4	202
150	10.1	11.9	6.6	8.2	199
175	10.6	12.5	6.9	8.6	192

### CLINICAL EVALUATION OF THE RESULTS OBTAINED

Defibrillation using biphasic waveforms is currently proving to be more effective than conventional monophasic waveforms because it requires less energy.

## A.5 RHYTHM DETECTION SYSTEM

The REANIBEX 100 Rhythm Detection System is an ECG signal analysis system that automatically discriminates between shockable and non-shockable rhythms.

In Automatic Defibrillator mode, the REANIBEX 100 analyses the ECG signal of the patient to determine whether it is necessary to deliver a shock. The Rhythm Detection System recommends a shock if it detects one of the following rhythms:

- Ventricular fibrillation with peak-valley amplitude of at least 0.2 mV
- Ventricular tachycardia with heart rate over 150 pulses per minute

Two independent ECG signal databases have been used to develop and verify the Rhythm Detection System. Each of these databases contain samples of different types of rhythms in both adult and paediatric patients, classified by expert doctors.

The types of rhythms that are used are:

- Ventricular fibrillation (VF)
- Ventricular tachycardia (VT)
- Normal Sinus Rhythm (NSR)
- Asystole (AS)
- Other arrhythmias such as atrial fibrillation, blocks, idioventricular rhythms, etc.

The databases used for verification have the following characteristics:

RHYTHM TYPE	NUMBER OF RHYTHMS	YIELD OBJECTIVE*	YIELD OBTAINED
<b>SHOCKABLE</b>			
Wide VF	247	>90% Sensitivity	>99% Sensitivity
Rapid VT	147	>75% Sensitivity	>99% Sensitivity
<b>NOT SHOCKABLE</b>			
NSR	458	>99% Specificity	100% Specificity
TSV	248	Not specified	>99% Specificity
AS	256	>95% Specificity	100% Specificity
Other	169	>95% Specificity	100% Specificity

\* Values established by the AHA (American Heart Association)

**NOTE:** For further information, consult the Technical Manual of the REANIBEX 100.

**A.6 ELECTROMAGNETIC COMPATIBILITY GUIDE**

The REANIBEX 100 has been designed and checked to comply with the requirements of radiated and conducted emissions in international standards. The following tables provide detailed information on the Electromagnetic Compatibility statement and guide.

The list of cables, transducers and other accessories with which Bexen cardio states compliance with the emission requirements and immunity of the EN 60601-1-2:2015 standard appears in Annex “**A.9 ACCESSORIES, CONSUMABLES AND COMPLEMENTARY TOOLS**”.

**WARNING**

**POSSIBLE ELECTRICAL INTERFERENCE**

The use of cables, pads or accessories not specified in this manual for use with the REANIBEX 100 can give rise to an increase in emissions or lower immunity versus electromagnetic or radio interferences. These interferences can affect operation of the defibrillator or of equipment in the immediate surroundings.

The REANIBEX 100 is intended to be used in the electromagnetic environments described in the following tables. The user of the equipment must ensure that it is used in these environments. REANIBEX 100 is defined as HOME environment use.

The following tables include the minimum recommended distances between the REANIBEX 100 and other portable and mobile communication equipment.

<b>ELECTROMAGNETIC EMISSIONS (EMC)</b>		
The REANIBEX 100 is intended to be used in electromagnetic environments such as those described in the following tables. The client or user of the REANIBEX 100 must ensure that the equipment is used in these environments. REANIBEX 100 is defined as HOME environment use.		
<b>Emission Test</b>	<b>Compliance</b>	<b>Electromagnetic environment - guide</b>
RF CISPR11 emissions	Group 1	The REANIBEX 100 does not use radio frequencies (RF) for internal operation. Therefore, its emissions are very low and it is improbable that they will cause interferences in nearby equipment.
RF CISPR11 emissions	Class B	The REANIBEX 100 can be used in any premises, including those connected directly to the public low voltage supply and that provide power to residential buildings.
Electrical Medical Equipment requires special precaution as regards EMC and must be installed and started-up with the EMC information provided in this document.		

## A.6 ELECTROMAGNETIC COMPATIBILITY GUIDE

<b>ELECTROMAGNETIC IMMUNITY</b>			
The REANIBEX 100 is intended to be used in electromagnetic environments such as those described in the following tables. The client or user of the REANIBEX 100 must ensure that the equipment is used in these environments. REANIBEX 100 is defined as HOME environment use.			
Immunity Test	Test level IEC 60601	Level of compliance	Electromagnetic environment - guide
Electrostatic discharge (ESD) IEC 61000-4-2	± 8 kV contact ± 2, ± 4, ± 6, ± 8, ± 15 kV air	Complies	Floors must be wooden, concrete or tile. If the floors are covered with synthetic material, relative humidity must be at least 30%.
Magnetic field at mains frequency (50/60Hz) IEC 61000-4-8	30 A/m	Complies	The magnetic fields must have the characteristics used typically in a commercial or serious hospital environment
			Mobile and portable communications RF equipment should not be used near any part of the REANIBEX 100, including the cables, at distances under those calculated by the equation that can be applied to the frequency of the transmitter.
Conducted RF IEC 61000-4-6	3 Vrms 150 kHz at 80 MHz outside ISM <sup>a</sup> bands 80%AM at 5KHz	3 Vrms	Applied on patient cables
	10 Vrms in ISM <sup>a</sup> and amateur radio bands 80%AM at 5KHz	6 Vrms	Applied on patient cables
Immunity to proximity fields from RF wireless communication equipment IEC 61000-4-3	Defined by the IEC 60601-1-2	Complies	Minimum distance : 0.3 m
			<b>Recommended intervening distances</b>
Radiated RF IEC 61000-4-3	10 V/m 80 MHz – 2,7 GHz 80% AM at 1 kHz	20 V/m	$d = 1.2 \sqrt{P}$ from 80MHz to 800MHz $d = 2.3 \sqrt{P}$ from 800MHz to 2.5GHz  P is the maximum output power of the transmitter in Watts (W) according to the manufacturer of the transmitter and d is the recommended intervening distance in meters (m) <sup>b</sup> .  As calculated by measuring the electromagnetic interference in site <sup>c</sup> , the field current of stationary RF transmitters must be lower than the level of compliance in each frequency <sup>d</sup> ranged.

## A.6 ELECTROMAGNETIC COMPATIBILITY GUIDE

			<p>Interference can occur in the proximity of equipment marked with the following symbol:</p> <div style="text-align: center;">  </div>
--	--	--	--

**NOTE:** These guide measures may not apply in all situations. Electromagnetic propagation is affected by absorption and reflection of buildings, objects and people.

<sup>a</sup> The degree of compliance in the frequency range from 80 MHz to 2.5 GHz has been included to reduce the probability of interference from mobile/portable communications equipment if inadvertently placed in patient areas. Therefore, an additional factor of 10/3 is used in the calculation of the intervening distances in these frequency ranges.

<sup>b</sup> The field current of stationary transmitters, such as radio base stations (cell or wireless), mobile, land and amateur phones and radios, AM and FM radio transmission and TV transmission cannot be accurately predicted. On-site measurement must be carried out to measure the electromagnetic interference of stationary RF transmitters. If the on-site field current measured using the REANIBEX 100 exceeds the applicable RF level of compliance, the REANIBEX should be monitored to check that it operates normally. If operation is not normal, additional measures should be taken, such as changing the orientation or location of the REANIBEX 100.

### RECOMMENDED DISTANCES BETWEEN MOBILE AND PORTABLE RF COMMUNICATION EQUIPMENT AND THE REANIBEX 100

The REANIBEX 100 is intended for use in settings where RF interferences are controlled. The client or user of the REANIBEX 100 can help to prevent electromagnetic interference by maintaining a minimum distance between mobile and portable RF communication equipment (transmitters) and the REANIBEX 100, as recommended below, depending on the maximum output power of the communication equipment.

Maximum transmitter output power <b>W</b>	Separation according to transmitter frequency (m)			
	150 KHz to 80 MHz outside ISM bands $d = 1.2 \sqrt{P}$	150 KHz to 80 MHz within ISM bands $d = 1.2 \sqrt{P}$	80 MHz to 800 MHz $d = 1.2 \sqrt{P}$	800 MHz to 2.5 GHz $d = 2.3 \sqrt{P}$
0.01	0.12	0.12	0.12	0.23
0.1	0.38	0.38	0.38	0.73
1	1.2	1.2	1.2	2.3
10	3.8	3.8	3.8	7.3
100	12	12	12	23

For transmitters with a maximum output power not specified above, the recommended distance of separation  $d$  in meters (m) can be calculated by using the equation applicable to the frequency of the transmitter, where  $P$  is the maximum output power in watts (W) according to the manufacturer of the transmitter.

**NOTE 1:** The distance of separation for the highest frequency is applied at 80 Mhz and 800 MHz.

**NOTE 2:** An additional factor of 10/3 is used in the calculation of the separation distances recommended for the 80 MHz to 2.5 GHz frequency range. This reduces the probability that the mobile/portable communications equipment will cause interferences if it is inadvertently placed in a patient area.

**NOTE 3:** These guiding measures may not apply in all situations. Electromagnetic propagation is affected by absorption and reflection of buildings, objects and people.

## A.7 CONNECTIVITY GUIDE

### 1 INTRODUCTION

This chapter contains the instructions necessary for the safe and appropriate use of the **REANIBEX Data Net** and **REANIBEX USB SYNC** applications.

The REANIBEX 100 can connect directly to **REANIBEX Data Net** by Wi-Fi or by USB, in this case using a PC with internet connection and the **REANIBEX USB SYNC** application.

The guide includes the information and procedures for monitoring the status of the REANIBEX 100, updating the configuration and/or software and downloading the episodes recorded by the equipment. The device you have purchased may not have all the features described in this chapter.

To determine whether your defibrillator has Wi-Fi, positioning (GPS) or Sigfox capabilities, check the icons of the serial number (SN) label located on the bottom of the equipment:



- If the word WIFI is present the REANIBEX 100 has Wi-Fi capability.
- If the word SIGFOX is present the REANIBEX 100 has IoT communication capability.
- If the symbol  is present the REANIBEX 100 has geolocation capability.

**NOTE:** Geolocation capability requires Sigfox or Wi-Fi capability in order to send the information to the **REANIBEX Data Net**. Geolocation will be sent during the monthly tests, when the user performs a Manual Test and when the equipment is used with a patient.

You should have an online account on the **REANIBEX Data Net** application. You received a single use KEY for the registration of the device. You can find this key in the QUICK GUIDE provided with the REANIBEX 100.

**NOTE:** The single use KEY is provided with the equipment. If you do not have the single use key please, contact Bexen cardio or an authorised representative of Bexen cardio.

### 1.1 REGISTER THE DEVICE

Some of the benefits of registering your REANIBEX 100 are (some features depend on your account type):

- Notification and possibility of updating the device with new software versions.
- Equipment configuration.
- REANIBEX 100 monitoring and geolocation
- Post event report download

Register the REANIBEX 100 in the REANIBEX DATA NET application taking the following steps:

1. Go to the **REANIBEX Data Net** website: <https://rdn.bexencardio.com>
2. Log in the site.

**NOTE:** If this is your first time and you do not have an account you must register and wait for an e-mail confirmation prior to registering any device. For that purpose, click on the “**CREATE ACCOUNT**” button and complete the form.

3. Once logged in the site, go to DEVICES area and click on the ADD button .
4. Select the group and the “REANIBEX 100” model.
5. Introduce the serial number (SN) and Single use KEY that you received in the QUICK GUIDE of the REANIBEX 100.

#### WARNING

This key can only be used to register the device once. Once used, it cannot be used again to register the device on another program. If you have any issues, please contact with Bexen cardio or an authorised representative of Bexen cardio.

### 1.2 REANIBEX USB SYNC APPLICATION

REANIBEX USB SYNC is a PC application which is used to transfer information between the REANIBEX 100 and the **REANIBEX Data Net** using the USB port and the USB cable provided with the device. You will also need a PC with internet connection.

PC requirements for installing the REANIBEX USB SYNC Application:

- PC with Windows® 7 or above operating system and an internet connection
- Administrator rights on the PC
- USB port (the cable is provided with the REANIBEX 100). The USB cable must be USB type 2.0 A Male to B male.

To install the REANIBEX USB SYNC Application in your computer, take the following steps:

1. Log in to your **REANIBEX Data Net** account using the name and password you obtained when you registered your first REANIBEX 100. If you did not receive the confirmation email contact an authorised representative of Bexen cardio.

**Note:** If you have changed your logon name and password, use those logon credentials instead.

2. Go to the RESOURCE CENTER area and select REANIBEX USB SYNC application.
3. Click the download app option to download REANIBEX USB SYNC.
4. After downloading the application, double-click the Setup.exe file to install it. If you don't see the file, look in your Downloads folder.

**Note:** If any security warnings appear, select the option to allow the installation of the file.

5. When the INSTALLSHIELD WIZARD appears, select your language and click OK.
6. When you see INSTALLSHIELD WIZARD COMPLETED, click FINISH.
7. Open the REANIBEX USB SYNC application. You will be prompted to enter your **REANIBEX Data Net** credentials. Enter the same logon name and password you use to log in to your **REANIBEX Data Net** account.
8. The REANIBEX USB SYNC will display information about all of the REANIBEX 100 devices you have registered in your REANIBEX Data Net.
9. Connect the REANIBEX 100 to the PC using the USB cable that was provided with the device. Refers to “Figure 3: Pads and USB connectors selectable by a sliding lid” to connect the USB cable to the REANIBEX 100.
10. Once the connection is established, select the serial number of the device you are connected to and the PC unit in which the equipment is (the name of the unit is REANIBEX100). The application will check that the data are correct. The equipment will send the information to your REANIBEX Data Net account and also will check for any updates you have indicated in the REANIBEX Data Net. In case there is any pending update the pending information will be downloaded.
11. The REANIBEX USB SYNC application will inform and guide you on the necessary steps based on the information that needs to be updated.
12. When you finish, disconnect the USB cable from the REANIBEX 100 and close REANIBEX USB SYNC application.
13. Confirm the status of the REANIBEX 100 online. For that access your REANIBEX Data Net account and check that the status of the device was successfully updated.

## 2 REANIBEX DATA NET FEATURES

**REANIBEX Data Net** application may include the following features, depending on your account type:

- Monitoring defibrillator status.
- Sending notifications: defibrillator position, battery or pads need to be replaced, defibrillator is turned on and pads applied to a patient, shock is delivered.
- Change settings for the defibrillator.
- Installing software updates.
- Sending episode
- On-line training in CPR (Cardio-pulmonary Resuscitation) and defibrillator use.

If the REANIBEX 100 is connected to **REANIBEX Data Net** (by Wi-Fi or using the REANIBEX USB SYNC application), Bexen Cardio may collect information to optimize the quality of the device.

### 2.1 LOGGING IN TO YOUR ACCOUNT

Before you attempt to connect the REANIBEX 100 to **REANIBEX Data Net**, you should confirm your account is active. Log in to your account using the name and password you obtained when you registered your first REANIBEX 100. If you did not receive the confirmation email, contact Bexen cardio or an authorised representative of Bexen cardio.

If you have changed your logon name and password, use those logon credentials instead.

## 3 CONNECTING THE REANIBEX 100

The REANIBEX 100 can have Sigfox capability. However it is not possible to upgrade the device firmware or send the recorded episodes using the SIGFOX connection and this has to be performed using the USB port of the equipment (application REANIBEX USB SYNC).

### 3.1 CONNECTING WITH SIGFOX

If your REANIBEX 100 has Sigfox capability, it will send alerts using this connection. However it is not possible to upgrade the device (configuration, software or resources) or send the recorded episodes using the SIGFOX connection.

To connect the REANIBEX 100 with Sigfox take the following steps:

1. Open the REANIBEX 100 cover. If it has automatically switched on, switch it off by using the ON/OFF button.
2. When the device is in stand-by mode, press the paediatric mode button while switching on the equipment with the ON/OFF button.
3. Check that the REANIBEX 100 issues the message "TEST MODE". A hardware test will be performed. After finishing the test, a voice message will be issued to describe the result of the test: "EQUIPMENT READY" if the result of the test is OK or "CALL TECHNICAL SERVICE" if any error was detected. In that case, please contact the Authorised Technical Service. The application REANIBEX NFC READER can be used to obtain more information regarding the obtained error.

**NOTE:** The voice messages "EQUIPMENT READY" and "CALL TECHNICAL SERVICE" indicates whether the REANIBEX 100 is ready for an emergency. It does not indicate whether wireless communication with the remote server is ready.

4. The REANIBEX 100 will attempt a Sigfox connection after the hardware test.
5. Once a Sigfox connection is established, the REANIBEX 100 will issue the voice message "TRANSMISSION IN PROGRESS" and will update your REANIBEX Data Net account with its current status and information.

**NOTE:** The REANIBEX 100 will issue the message "TRANSMISSION IN PROGRESS" several times during the process.

**NOTE 1:** If there is any error during the connection or transmission, the REANIBEX 100 will issue the voice message "CONNECTION ERROR", and will finish the transmission.

6. When all updates are complete, you will hear the voice message "TRANSMISSION COMPLETED". Confirm the REANIBEX 100 status in your REANIBEX Data account (refer to section 4.4 CONFIRMING AED STATUS ONLINE).

### 4.2 CONNECTING WITH USB

It is possible to connect the REANIBEX 100 to the **REANIBEX Data Net** without using Wi-Fi or Sigfox. It can be done using the REANIBEX USB SYNC Application and the USB cable provided with the defibrillator. To connect the REANIBEX 100 using the USB connection see section "1.2 REANIBEX USB SYNC APPLICATION".

To connect the REANIBEX 100 with USB take the following steps

1. Open and log in to the REANIBEX USB SYNC application. Refer to section 1.2 REANIBEX USB SYNC APPLICATION.
2. When you finish, disconnect the USB cable from the REANIBEX 100 and close the REANIBEX USB SYNC application.
3. Confirm the status of the REANIBEX 100 online. For that access your **REANIBEX Data Net** account and check that the status of the device was successfully updated.

### 4.3 CONFIRMING AED STATUS ONLINE

To confirm that the REANIBEX 100 successfully updated its status, take the following steps:

1. Log in to your **REANIBEX Data Net** as described in section "2.1 Logging in to Your Account".
2. Go to the DEVICES page and verify the status of your device.
3. If the status of the device is not  contact the Authorised Technical Service.



## 5 UPDATING SETUP OPTIONS, RESOURCES AND SOFTWARE

Description of available setup options is provided in section "5.2 Configurable parameters". It is possible to update setup options or software using USB connection. Also it is possible to upload the recorded episodes by USB connection.

### 5.1 SPECIFY UPDATES TO APPLY

**NOTE:** Any updates you specify will be applied to all REANIBEX 100 in the selected group.

In order to specify the updates to apply to the REANIBEX 100 devices, take the following steps:

1. Log in to your **REANIBEX Data Net** as described in section “2.1 Logging in to Your Account”.
2. Select the group.
3. Click the CONFIGURATION icon  to display the available setup options.
4. Change the configuration options as desired.
5. If there is a new software available, click the icon , authorize and schedule the update.

### 5.2 UPDATING SETUP OPTIONS OR SOFTWARE WITH USB

To update the setup options or software with USB you will need the REANIBEX USB SYNC application and the USB cable provided with the device. You will also need a PC with internet connection. It is possible to update the REANIBEX 100 using the USB connection even if the equipment has Wi-Fi capabilities.

To update the REANIBEX 100 with USB take the following steps:

1. Open and log in to the REANIBEX USB SYNC application. Refer to section 1.2 REANIBEX USB SYNC APPLICATION.
2. Follow the instructions indicated by the REANIBEX USB SYNC application until the process is completed.
3. When you finish, disconnect the USB cable from the REANIBEX 100 and close REANIBEX USB SYNC application.
4. When the device is in stand-by mode, press the paediatric mode button while switching on the equipment with the ON/OFF button to perform a MANUAL TEST. Refer to section 5.3.1 MANUAL TEST for more information.
5. When the test finishes, the REANIBEX 100 will start the upgrade of the information by issuing the message “UPDATE IN PROGRESS”. When the update has finished the REANIBEX 100 will reboot. The equipment will be silent for 1-2 minutes while upgrading the software. After the updates are complete, the equipment will issue the message “EQUIPMENT READY”.

**NOTE:** If there is any error during the upgrade the REANIBEX 100 will issue the message “NO UPGRADE PERFORMED”.

Close the cover and check that the status indicator flashes, if not contact the Authorised Technical Service

6. Confirm the status of the REANIBEX 100 online. For that access your **REANIBEX Data Net** account and check that the status of the device was successfully updated.

### 5.3 VERIFY UPDATES

To confirm that the REANIBEX 100 is successfully updated, take the following steps:

1. Log in to your **REANIBEX Data Net** as described in section “2.1 Logging in to Your Account”.
2. Go to the DEVICES page and verify the status of your device.

- If the status of the device is not  check the cause of the error and if necessary contact the Authorised Technical Service.

## 6 TROUBLESHOOTING

The following table lists the main problems that can occur in the REANIBEX 100 with connection capabilities; the indication provided by the equipment, the possible cause and the measure required to solve the problem.

SYMPTOM	POSSIBLE CAUSE	POSSIBLE SOLUTION
REANIBEX Data Net indicates that the REANIBEX 100 does not sent information on its status	The REANIBEX 100 has moved to a location that does not have adequate Sigfox signal strength	<ul style="list-style-type: none"> <li>• Check that the REANIBEX 100 is located in an area with good signal strength.</li> </ul>
	The REANIBEX 100 has a problem or is not registered in the REANIBEX Data Net	<ul style="list-style-type: none"> <li>• Check the status indicator LED of the REANIBEX 100. If not flashing, follow the instructions in section “8 Troubleshooting”.</li> <li>• Follow the instructions on the provided QUICK GUIDE to register the device in the REANIBEX DATA NET.</li> <li>• Contact the Authorised Technical Service.</li> </ul>
It is not possible to connect the REANIBEX 100 with the REANIBEX USB SYNC application	Incorrect USB cable	<ul style="list-style-type: none"> <li>• Use the cable provided with the REANIBEX 100 equipment.</li> </ul>
	USB cable not properly connected	<ul style="list-style-type: none"> <li>• Check that the USB cable is firmly inserted in the USB port on the REANIBEX 100.</li> </ul>

## **A.8 CYBERSECURITY**

### **1 INTRODUCTION**



Every day, the number of IoT devices that are being setup has increased drastically; and with them the Cyber-Attacks that these devices may suffer.

This guide aims to help administration personnel to securely setup the REANIBEX 100 devices on their network/environment, for devices both with and without communications. This is a basic guide and it may be necessary to take extra security measures depending on the requirements of the network/environment.

#### **1.1 INTENDED USE**

This guide is directed to system and network administrators that want to setup REANIBEX devices like the REANIBEX 100. The personnel responsible for the setup and maintenance of devices and networks need to be trained professional with a background in IT and/or IT security.

#### **1.2 ICONS REFERENCE**



<b>INFORMATION</b>	<b>HOW TO USE</b>	<b>ICON</b>
DANGER	Never do or allow it to happen.	
WARNING	Can be done sparingly and/or with extra cautions, while a better solution is set up	
CORRECT	Can be done or used – may need a correct configuration -	

## **2 Wi-Fi**

The Wi-Fi networks can be used to attack devices and computers connected to them if they are configured improperly. This section includes a series of recommendations for the configuration of these networks.

### **2.1 CONNECTION PROTOCOLS**

Wi-Fi networks can be accessed by using multiple connection protocols, some of which shouldn't be used due to insecure protocols, and other should be used only when properly configured.

<b>PROTOCOL</b>	<b>HOW TO USE</b>	<b>DO/DON'T</b>
WEP		
OPEN	Only for testing	

NETWORK		
WPS		<b>X</b>
WPA-PSK	Long Passwords, New/Patched access points and connected machines, encrypted communications (TLS/HTTPS)*	✓
WPA2-PSK	Long Passwords, New/Patched access points and connected machines, encrypted communications (TLS/HTTPS)*	✓
WPA-EAP	New/Patched access points and connected machines, secure certificate management, encrypted communications (TLS/HTTPS)*	✓
WPA2-EAP	New/Patched access points and connected machines, secure certificate management, encrypted communications (TLS/HTTPS)*	✓

\* The devices on the networks should communicate with other devices/machines/servers on the network or in the internet using by default secure encryption (or at least it should be possible to configure the encryption of the transmission).

**WARNING**

WPA3 is the successor of WPA2, but at the time of this document this protocol is not widely used, and has presented several vulnerabilities in the sort time that it has been released. Because of this, at the time of writing this document the REANIBEX 100 does not support the WPA3 protocol and it will not be supported until WPA3 reaches a certain level of stability.

**2.2 CONSIDERATIONS**

Connections like WEP, OPEN NETWORKS and WPS, are insecure because they allow unwanted users to access the WiFi network without the proper credentials. This can lead to the devices on the network to be attacked by a malicious user that gains access to the network exploiting these protocols vulnerabilities. Connections like WPA and WPA2 are less likely to be broken as long as proper password practices are used – long not easy to guess passwords -. These protocols still suffer from some problems that may make the traffic of the network visible to external user, as such, it is important to use devices and machines that encrypt communications between them and other devices/machines/servers, for example using TLS.

### 3 NETWORK

Once in the network, even in a securely configured WiFi, the REANIBEX 100 can be exposed to attacks by compromised devices/machines on the network - this includes the router itself -. While the REANIBEX 100 is designed to mitigate most of the known issues, it is recommended to keep the network secure in order to reduce the impact that a compromised device/machine may have on both the REANIBEX 100 and the rest of the devices/machines present on the network.

These are some of the actions that should be taken to secure the network. Depending on the network more actions may be required. In case of doubt, consult a network security expert.

<b>ACTION</b>	<b>STEPS</b>
KEEP DEVICES/MACHINES UP TO DATE	<p>To prevent that old vulnerabilities affect the network, keep the devices and machines updated:</p> <ol style="list-style-type: none"> <li>1. Check on a regular basis for any available update of those devices on the network, and patch them if there's any new update - this needs to be done even if the devices do not have automatic updates -.</li> <li>2. Replace devices that are no longer maintained by the manufactures. If not possible, limit their access to the network.</li> <li>3. Update devices from official sources.</li> </ol>
KEEP DEVICES/MACHINES SECURE	<p>To prevent the devices/machines to be infected by unwanted software, use antivirus software on those devices/machines that allow its use. Scan the devices/machines on a regular basis, and check any new file.</p>
FIREWALL	<p>Limit the traffic that can reach each device and what each device can reach by setting up firewall rules that controls the traffic on the network.</p>
NETWORK SEGMENTATION	<p>Segmentate the network by isolating zones that presents a security problem for the rest of devices/machines. For example, isolate those devices/machines that are not longer maintained by manufacturers from the rest of the network.</p>
MONITORING/NOTIFICATIONS/ INVESTIGATIONS	<p>Set up network monitoring tools that will check the network for unwanted and/or anomalous traffic. Send notifications when these events occur. Investigate the events in order to rule out possible threats.</p> <p>Set up response protocols that make employees notify any perceived anomalous machines/devices behaviour or traffic and investigate it.</p>
ROUTINE REVIEW OF VULNERABILITIES	<p>Routinely review the public vulnerabilities of the devices/machines present on the network and apply any needed maintenance operation. It is recommended to automate this by, for example, subscribe to vulnerabilities newsgroups and/or databases.</p>

<p>TRAIN PEOPLE</p>	<p>Train employees and other people that use the network and or devices/machines on them, on how to avoid common security mistakes and attacks, and raise awareness in the company about cybersecurity. As a starting point a list of basics do and don't of security for employees can be found on section 7. Training Tips.</p>
---------------------	---

**3.1 SECURE MANAGEMENT OF SECRETS**

Keep secrets like user/devices/machines passwords and certificate securely store.

WHAT TO DO	DO/DON'T
Store only the necessary credentials	✓
Setup secure password restoration systems, only used by privileged users	✓
Securely Distribute secrets (encryption, secure channels)	✓
Revocation of credentials	✓
Limited and Temporal credentials for new people and guests (if necessary)	✓
Plain unencrypted secrets storage	✗
Secure storage of certificates (secure machine, limit access)	✓
Use official CA authority for certificate generation, or store the CA on an offline device and encrypted	✓
Access levels for secrets	✓
Manage password in unencrypted files (with names like password.txt)	✗
Use, known and secure, secrets management applications	✓

## 4 SECURE ENDPOINTS

REANIBEX devices like the REANIBEX 100 use external applications and services to help with the management of the device; like updates, tests, logs reporting.

These applications and services will be installed in the users' computers and devices. In order to prevent these computers/devices from being used to attack the devices or to steal credentials, it is important to keep them secure.

DEVICE	HOW TO USE	DO/DON'T
COMPUTERS	Keep the system and software updated Use a good antivirus scanner and regularly analyze Limit the input of external USB storage devices and CD/DVD Limit internet traffic and web site access	✓
	Install programs from unknown/illegal sources View files from unknown/illegal sources Browse unknown or dubious pages Use old machines without maintenance from Microsoft Allow the use of the machine by third parties	✗
SMARTPHONES	Keep the system and software updated Use a good antivirus scanner and regularly analyze Limit the input of external usb's	✓
	Install APP's from unknown sources Use a personal phone Install APP's outside of the Play Store Use old devices without maintenance from the manufacturer Allow the device to be used by third parties Browse unknown or dubious pages Connect the USB to unknown computers or charging stations Use rooted devices	✗
ROUTERS ACCESS POINTS FIREWALLS	Keep the devices update Monitor the network for traffic out of the devices Properly configure the devices	✓
	Use devices without maintenance from the manufacturer Use the default users, passwords and certificates Use old devices with vulnerable protocols/algorithms Use devices with known critical unfixed vulnerabilities	✗

## 5 SECURE ENVIROMENT

Any security measure taken may be of no use if the publicly displayed devices can be accessed by anyone that passes by without being noticed. This can cause the device to be stolen or manipulated physically.

While REANIBEX 100 devices with communications may be able to notify when a device is being used, devices without them will not be able to notify the users at the time of the event.

As such it is import to keep some level of security on the environment in which the devices are setup.

Here is a list of good practices that can be implemented, and while **it is not necessary to implement them all** – due to the limitations of each user - **it is recommendable to implement as much as possible or develop similar practices** that helps keep the devices secure.

WHAT TO DO	DO/DON'T
Keep connected the devices that have communications	✓
Keep the devices in a place that is regularly checked by a security guard or other personnel	✓
Keep it in sight of a security camera	✓
Keep it in sight of responsible/management personnel	✓
Routine maintenance (see [section 6])	✓
Keep it in a showcase with security measures that reduce the possibility of device being stolen	✓

## 6 ROUTINE MAINTENANCE

Routinely check the REANIBEX 100 devices state in case any error may appear or in case it may have been manipulated. It is also important to regularly check for any new updates to keep the devices up to date.

WHAT TO DO		DO/DON'T
Maintenance frequency	Weekly	✓
	Monthly	✗
	Yearly	✗
Update devices		✓
Review tests for errors		✓
Review logs/notifications and check for unknown usages		✓
Check for any new scratch or bump – especially near the screws and the device joints -.		✓
Check that the wax on the screw/s is still intact		✓
Check that the communications works		✓

Review the device documentation to check how to properly update and check logs and tests. In case of any error or problem contact authorised technical service staff.

## 7 TRAINING TIPS

This annex provides a list of basics do and don't of security for employees. This is a basic list and it may need to be extended depending on the security/system needs of each company.

TASK	DO/DON'T
Run programs received by email or third parties	✗
Open files from unknown emails	✗
Scan files from known emails/sources before using	✓
Insert unknown usb drives/CD-ROM/DVD on a computer	✗
Use personal usb/devices/CD-ROM/DVD without previously notifying IT	✗
Routinely use the virus scanner	✓

Keep Computers/Devices/Software updated	✓
Reuse Passwords across accounts or use short/easy to guess passwords	✗
Share system information/credentials by email or phone with people without confirming their identity	✗
Accessing unknown or dubious web pages	✗
Store passwords on the computer without encryption or in a post-it on the desktop	✗
Report when the computer starts to act “weird” or slows down significantly	✓
Send sensitive data by email	✗
Use well known virus scanners, or approved by IT	✓
Use software from unknown/illegal sources	✗
Download/Store/View files from unknown/illegal sources (P2P)	✗
Delete emails with unusual subject lines from unknown sources	✓
Report to IT when receiving emails with unusual subject from known sources.	✓
Report to IT when emails have files with extensions like .exe, .vbs, .js, .jse, .wsf, .vbe, .wsh	✓
Allow the use of macros on files (spreadsheets, documents) from sources outside of the company.	✗
Perform operations on computers/devices based on requests received by email or phone, without confirming the identity or the requester, or reporting to IT first.	✗
Report when a portable device with access to the system or that contains sensitive data has been stolen/lost	✓
Allow third parties/family/friends to use computers or devices that can access the system or that contain sensitive data	✗
Connect personal or external devices/computers to the network without reporting to IT first	✗
Deleting or performing actions on the system/software/files of the devices/computers that could damage or delay the operations of the system/company.	✗

## A.9 ACCESORIES, CONSUMABLES AND COMPLEMENTARY TOOLS

### A.9 ACCESSORIES, CONSUMABLES AND COMPLEMENTARY TOOLS

This Annex provides information about the accessories, consumables and complementary tools available for the REANIBEX 100. To submit an order, please contact Bexen cardio or one of its authorised distributors.

DESCRIPTION		REFERENCE
PADS	Pre-connected disposable defibrillation pads for adults and paediatrics	KSA 0502
POWER SUPPLY	Disposable LiMnO <sub>2</sub> battery	DJS 3000
OTHER	Warranty certificate	--
	Cover	DJS 1000
	USB A to USB B cable	KIA 0303
	REANIBEX DATA NET, Web application for monitoring status and information of the equipment and its accessories.	DJI 0010
	REANIBEX USB SYNC, PC application for data synchronization with the REANIBEX DATA NET	DJI 0020
	REANIBEX NFC READER: Android application for monitoring equipment and accessories status	DJI 0100