

Heraeus

HERASAFE® HS/HSP SAFETY CABINETS

All you need for safety



YOU CANNOT AFFORD TO COMPROMISE ON SAFETY

Heraeus® HERAsafe Safety Cabinets are used in environments where high levels of protection and safety are required. Whether in biotechnology, microbiology, genetics or research, whether in laboratories, pharmacies, clinics or hospitals – the carefully perfected overall concept of these safety cabinets pays off in practice. Safely.

Unique: Aerosol tight front window

The patented, aerosol tight, motor-driven front window with laminated safety glass guarantees secure protection from contamination. This innovative window offers many advantages:

■ **Electrically powered:**

Easy to operate.

■ **Safety lock:**

Sample GUARD®: Personal- and product protection of the work area during stand-by operation.

■ **Exceptionally economical:**

The aerosol tight front window enables contamination protected breaks in working without time intensive disinfection of the work area. Thanks to the energy saving mode, outstanding economy is guaranteed when the window is closed.

■ **Maximum protection:**

From contamination through mechanical damage, along with the best protection from UV light.

■ **Further advantages:**

High heat stability, easy to clean, no tarnishing or scratching.

Leading the way: Practise orientated design

HERAsafe Safety Cabinets offer the optimum mix of quality, functionality and safety. Here are just some examples of the equipment concept, which has been perfected down to the very last detail:

■ **Electrical monitoring system:**

To monitor airflow, air speed and the filter system.

■ **Safety negative pressure:**

All ducts and plenums which can be contaminated are surrounded by negative pressure. If, in fact, in any way a leak occurs, all contaminants are returned to the pressure chamber.

■ **Ergonomic accessories:**

For working in comfort and safety: patented arm rests, for instance.

■ **H 14 – HEPA Filter in accordance to EN 1822:**

For minimum absorption of 99.999% (on 0.3 microns).

■ **Modular equipment concept:**

Tailor made solutions for your need.

■ **Automatically stand-by:**

The automatic stand-by secures

- energy saving
- keep cleanroom inside
- ensures aerosol tightness





MEETING A HOST OF EXACTING REQUIREMENTS

HERAsafe Safety Cabinets comply with national and international safety regulations, offer optimum operator, product and environmental protection, are designed for daily practise and are easy to clean and to maintain. All these factors add up to perfection that is available in three different versions:

HERAsafe HS – the standard model

Class 2 Safety Cabinets in accordance with international standards. Ideal for microbiology, biotechnology and genetics applications within safety categories 1 to 3.

HERAsafe HSPC with activated carbon prefilter

Equipment as HERAsafe HS, plus an additional activated carbon prefilter. This makes the HSPC model particularly suitable for working with chemical and toxic substances.

HERAsafe HSP – for more exacting demands

The HERAsafe model HSP Safety Cabinet has been designed to meet more demanding safety requirements, and offers a further HEPA H 14 filter level in addition to the standard equipment – which ensures greater personal, product and environmental protection.

This model is particularly suited for example for production of cytostatics or other works in which hazardous toxic chemicals are involved, and for work in pharmaceutical or L 3 laboratories. Meets additionally DIN 12980 safety regulations.

HERASAFE HS – PERFECT FOR PRACTICAL WORK

Thanks to its modular design and the large range of accessories and options available, the standard HERAsafe model is ideal for use within microbiological laboratories in categories 1 to 3.

A safety cabinet with convincing assets:

- Especially designed for work with dangerous biological substances
- Optimum contamination protection
- High product and personal/operator protection from contamination
- Vertical laminar air flow and air intake (air curtain) across front opening
- Modular design for flexible, individually orientated use
- Safety tested in accordance with
 - BS 5726 tested by CAMR (Porton Down)
 - IEC 1010-1 tested by SEV
 - DIN 12950 tested by TÜV PS
 - NFX-44-201 tested by LNE
 - NSF 49 tested by NSF



The aerosol tight, motor-driven front window

Fully equipped

HERAsafe offers everything that's needed for safe, problem-free work with infectious and contamination-prone materials. Some performance examples:

Motor-driven front window

Optimum protection through hermetically sealing, aerosol tight lock. The effect: contamination cannot enter or leave.

Monitoring system

Permanent monitoring of all relevant safety functions via monitor control system.

User friendly

Tailor made for daily work: straightforward control panels and a bright, well lit, glare free work area. All functions can easily be checked whilst remaining seated.

H 14 HEPA filter

HERAsafe is equipped with a High Efficiency Particle Air Filter (HEPA) which guarantees a minimum absorption of 99.999% on 0.3 microns (99.995% on 12 micron MPPS).

Negative pressure encapsulation

For optimum contamination protection: should a leak occur in the sealing system, all particles are returned to the pressure chamber and caught by the filters.



Clean air in the work chamber supply

The air supply filter which is protected against heat or irradiation damage by laminator grid sheet, circulates clean air throughout the whole work area. Clean Room Class A (acc. to EC guide) or class 100 (acc. to Fed. Std. 209) are easily superseded in safe work area inside.

Ease of cleaning

With the HERAsafe, cleaning and disinfecting is a fast and easy task: all surface areas within the work space are made from smooth, easy to clean materials. The side windows are made from scratch, acid and UV-light resistant safety glass, the work surfaces and the water tray from stainless steel. A further advantage: rounded corners inside the work chamber.

Individual application options

HERAsafe HS models are also available with the following work chamber widths: 90, 120, 150 and 180 cm.

A variety of options extend our safety cabinets' possible applications.

Ergonomic accessories such as the patented arm rests, which do not block the air slots, or balance inlays or UV-irradiators in different variations ensure a fatigue-free work environment.

The right solution for every requirement

Do you have specific equipment needs? Are you thinking about individual extras? Would you like more accessories? Thanks to the many different equipment and accessory options available, we can offer you a solution tailored to your precise needs.

Please refer to page 13 for technical information on HERAsafe.



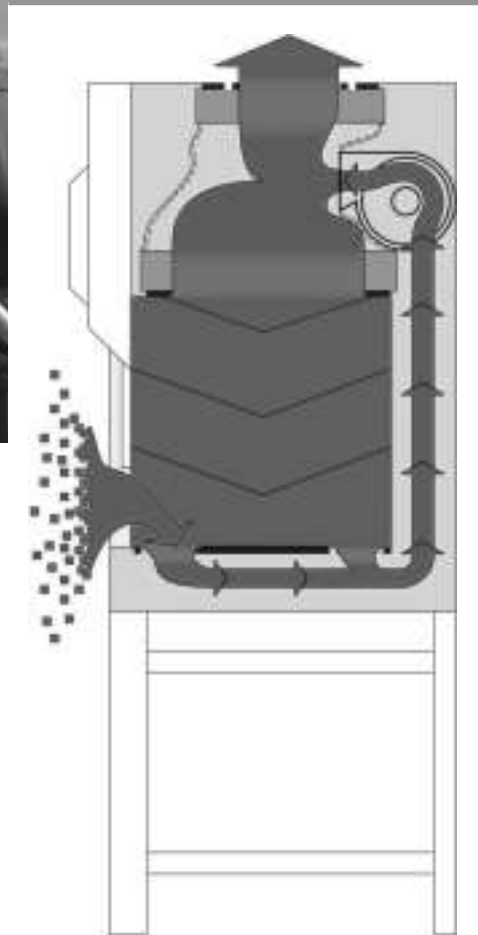

HERAsafe HS air-flow pattern

- Contaminated air
- Mixed air
- Filter
- Clean air

HERASAFE HSP/HSPC WITH PREFILTER – EXCELLENT SAFETY

Every HERAsafe Safety Cabinet is a synonym for optimum safety and frequent testing to the highest standards.

The HERAsafe model HSP Safety Cabinet has been specifically designed for exacting safety demands.

Additionally certified in accordance with DIN 12980

- Especially for work in which toxic chemicals are involved, e. g. cytotoxic drug preparation

High performance prefilter

- modular cartridge filter before supply and exhaust air filter
- filter exchange with a minimum contamination risk
- equivalent to class H 14
- contamination risk reduced by factor 100,000
- awarded with the 'Umwelt-preis Klinik 1996' [1996 Environment Clinic Award]



HERAsafe HSP prefilter element for contamination free exchange of filters

Fully equipped

Naturally, the HERAsafe HSP/HSPC also offers all the features of the HERAsafe HS:

- Aerosol tight front window
- Monitoring system
- Exceptionally user friendly
- HEPA-filter
- Negative pressure encapsulation
- Pure air in the work area
- Ease of cleaning
- Ease of disinfection

Award winning

The HERAsafe HSP range is additionally equipped with a H 14 prefilter which is equivalent to the safety cabinet class H 14. Accordingly, this safety cabinet is ideal for the preparation of cytostatics.

A modular cartridge filter is positioned in front of the supply and exhaust air filter. Re-contamination is practically impossible. The prefilter can be changed with a minimum contamination risk while the safety cabinet is in operation.



The award winning HERAsafe HSP Cytostatic Safety Cabinet

Safety tested in accordance with

- **BS 5726** tested by CAMR (Porton Down)
- **IEC 1010-1** tested by SEV
- **NSF 49** tested by NSF and TÜV
- **DIN 12980** tested by TÜV PS
- **DIN 12950** tested by TÜV PS



Individual application options

HERAsafe HSP and HSPC models are also available with the following work chamber widths: 90, 120, 150 and 180 cm.

A variety of options extend our safety cabinets' possible applications.

Ergonomic accessories such as the patented arm rests, which do not block the air slots, or balance inlays or UV-irradiators in different variations ensure a fatigue-free work environment.

This high performance air circulation concept has been honoured with the 1996 Environment Clinic Award, which awards the prevention of large volume, dangerous filter waste.

The German Head of Federal Administration, Darmstadt, recommends the concept of HERAsafe for the operation with air recirculation in cytotoxic drug laboratories.

Additional active carbon prefilter

The HERAsafe model HSPC offers an additional activated carbon prefilter instead of the H 14 prefilter, which makes it ideal for specialised applications requiring an active carbon filtrate either for recirculated air inside and exhaust.

Technical data for HERAsafe HSP/HSPC can be found on page 14.

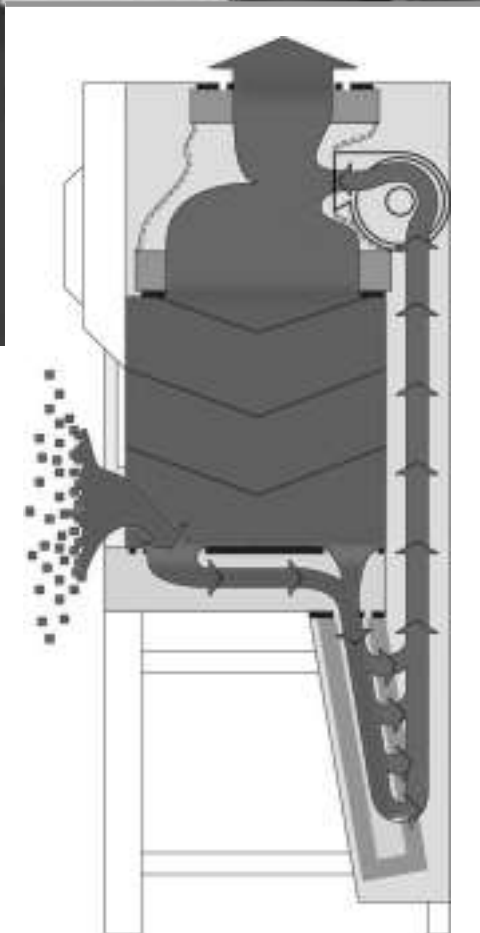

**HERAsafe HSP/HSPC
(prefilter as carbon filter)
airflow pattern**

- Contaminated air
- Prefiltered air
- Mixed air
- Filter/prefilter
- Clean air

PERFECTED DOWN TO EVERY LAST DETAIL

Do you want to equip your HERAsafe Safety Cabinet with optimum operational and user comfort in mind? Are you thinking of the special arm rests, for example, flexible media connections or specialised work surface modules? Thanks to our large range of accessories and options we are well equipped for every special requirement. Some examples:

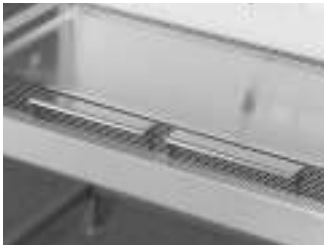

Arm rests:
Safe and comfortable:
Patented, ergonomic arm rests which are inter-connectable. Ideal for preventing blockage of the air slits whilst conducting experiments.



Media taps:
Higher flexibility
Whether for vacuum, gas or other media – taps in the side or back panel offer more creative freedom whilst working.



Extra outlets:
More possibilities
Additional sockets needed? Naturally!



Thimble Duct Connector:
For good connections
Ideal for connecting HERAsafe on inhouse exhaust systems.





**UV-C lights:
Very efficient**

High performance UV-C lights with short irradiation duration. Optionally either securely fixed into the side panels or as a mobile light for flexible use (254 nm wave-length).

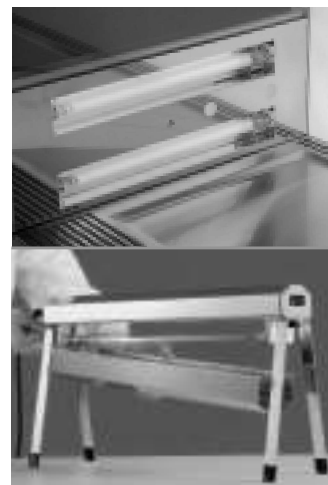

**Work table top modules:
Designed for practical work**

The lowered, smooth work surface firstly ensures a safe work area and secondly prevents small quantities of material from reaching the water tray. A low vibration granite stone is available as an optional extra – ideal for balances and working with microscopes.



**Support frames:
Very adaptable**

Offering different heights for standing or seated work, or with castors for cabinet mobility. With adjustable feet for the secure positioning of the safety cabinet.



**Safety burner:
For every laboratory**

The high performance vulcan Laboratory Safety Bunsen – ideal for measured heating up and problem free sterilization.



INDIVIDUAL AND PERSONAL

Tailor made

Every product made by Kendro Laboratory Products offers top quality. Moreover, the custom options that are available ensure that the equipment fits in with your lab surroundings and meets your specific needs – a must for safe, efficient working.

Everything from one source

Our expert advice is invaluable. We consider everything which is of importance to you today and which may become important to you tomorrow. Let us advise you on our extensive range of accessories and options, which offers you many different perspectives and possibilities. Some examples are shown on this page.

Just talk to us about your needs and individual requirements.



HERAsafe HS 1-12 Ex ▲

Safety cabinet specifically for the processing of explosives. For personal/operator protection requirements similar to class 1 cabinetry.



HERAsafe DS

Safety cabinet with two workstations and opposite work access which principally meets all requirements of a class 2 safety cabinet. After closing off one front access it can also be used as a single workstation.



Total exhaust ▲

Ideal for work with higher amounts of toxic materials. 100% exhaust air removal without recirculation into the room. Recontamination risk is reduced. Complies with the requirements of the American standards NSF- 49 type B2 cabinetry.

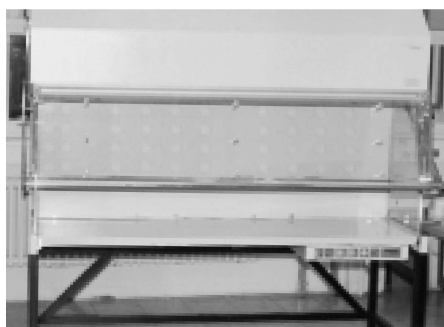

Fume bench ▲

Clean bench with horizontal purified air flow and partial air suction through the front access. For specific work requiring limited personal/operator protection. Fulfills the requirement profile for product protection.



Clean air carrier ▲

Mobile pure air station with a battery for transporting sensitive materials. Fulfills the requirements of product protection. Purified transport of materials in clean areas.



HERAGuard HPH ▲

Clean bench with optimum product protection through horizontal airflow across the entire work surface.

MORE THAN YOU EXPECT

One of the best addresses

We think of ourselves as your partner, offering you competent, safe, reliable solutions. Individual support and specialist advice is available from highly qualified sales and service staff, who will quickly and competently help you with any questions you may have.

But Kendro perfection begins with innovative equipment that incorporates a broad range of features – all designed to meet the many and diverse requirements of your daily work.

Kendro Laboratory Products helps you reliably. Safely.

Examined with a close eye

Every piece of equipment undergoes strict quality control and extensive testing before it leaves our manufacturing sites. Delivery lorries only leave the yard when the experts in the test laboratory have given their thumbs up!

Tried and tested in many areas

Whether in the field of genetics, biotechnology, microbiology or research, our safety cabinets perform valuable tasks, day in and day out.

Setting the standard for quality

The most modern production methods and the highest quality components, in combination with careful finishing, guarantee that our safety cabinets are quality products, renowned for their long term reliability and safety.



Individual testing of the filter's efficiency in our quality laboratory ▲



Visual testing and production of a test protocol ▲



Testing of electrical safety ▲



Sealing of components ▲



Assembly of mechanical components ▲



Final assembly of pre-fabricated assembly groups ▲

TECHNICAL DATA

HERASAFE HS

Type	Unit	HS 9	HS 12	HS 15	HS 18	
External dimensions HS¹⁾	(w/h/d)	mm	1002/1425/940	1302/1425/940	1602/1425/940	1902/1425/940
Internal dimensions	(w/h/d)	mm	900/650/630	1200/650/630	1500/650/630	1800/650/630
Opening to work area	(w/h)	mm	900/~200	1200/~200	1500/~200	1800/~200
Lifting height of front window		mm	~500	~500	~500	~500
Input dimensions⁴⁾	(w/h/d)	mm	1000/1425/940	1300/1425/940	1600/1425/940	1900/1425/940
Minimum door opening	(d)	mm	770 (window frame and back panel dismantled)			
	(d)	mm	810 (control unit dismantled)			
Adjustable support frame						
Dimensions of support frame ³⁾	(w/h/d)	mm	1002/680 ± 20 /800	1302/680 ± 20 /800	1602/680 ± 20 /800	1902/680 ± 20 /800
working height		mm	785 ± 20	785 ± 20	785 ± 20	785 ± 20
Weight	Equipment	kg	approx. 175	approx. 200	approx. 250	approx. 270
Loading capacity of the work surface						
with continuous work surface		kg		50		
with segmented work surface		kg		25		
Technical verification						
Exhaust air/fresh air supply volume		m ³ /h	~360	~480	~590	~710
Air circulation volume		m ³ /h	~840	~1100	~1380	~1660
Total re-circulated air volume		m ³ /h	~1200	~1580	~1970	~2370
Holding power						
at 25 °C room temperature		kW	~0.45	~0.45	~0.75	~0.75
Heating up to approx. 10 K above room temperature with window closed						
Filter technology						
Air circulation/exhaust air filter	type		H 14 HEPA (in acc. EN 1822)			
Additional AEF	filtering efficiency		99.999% at 0.3 µm particles			
(most features, HS only)	Class (DIN 24 184)		better than class S			
Noise (in accordance with DIN 12 950)						
Noise pressure level		dB (A)	<60	<60	<60	<60
Lighting power		lx	> 1000	> 1000	> 1000	> 1000
Electrical data						
Voltage ²⁾		V	1/PE AC, 230	1/PE AC, 230	1/PE AC, 230	1/PE AC, 230
Frequency		Hz	50	50	50	50
Power consumption		kW	0.75	0.75	1.3	1.3
Current		A	3.3	3.3	5.7	5.7
Protection class			I	I	I	I
Type of protection			conductor connection			
Protection type			P 20			
Indiv. precautions on customer side			Lead fuse (slow blow) T 16 A or circuit breaker B 16. The electrical regulations in the country of use as well as the relevant connection conditions must be observed.			
Protected electrical outlets in work chamber			230 V, T5A Each outlet can bear up to 5A and is selectively protected with T 5 A fuses. When all outlets are used simultaneously, they must not exceed the maximum total load of 5 A.			
Radio interference			Circuit is interference free in accordance with EN 55 014			

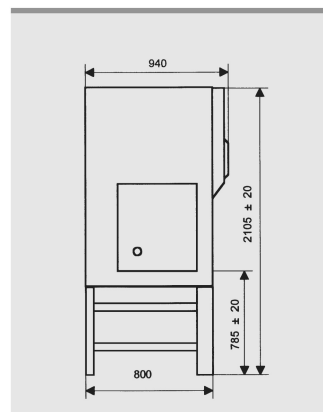
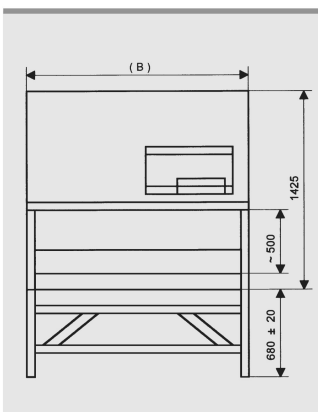

- 1) Further dimensions on request
- 2) Further voltages on request
- 3) Further support frames on request
- 4) Equipment and support frame are delivered individually. Installation and assembly on-site.

HERAsafe HS overview of dimensions

TECHNICAL DATA

HERASAFE HSP/HSPC

Type			HSP 9	HSP 12	HSP 15	HSP 18
Internal dimensions HSP¹⁾	(w/h/d)	mm	1002/2105/940	1302/2105/940	1602/2105/940	1902/2105/940
External dimensions	(w/h/d)	mm	900/650/630	1200/650/630	1500/650/630	1800/650/630
Opening to work area	(w/h)	mm	900/~200	1200/~200	1500/~200	1800/~200
Lifting height of front window		mm	~500	~500	~500	~500
Input dimensions⁴⁾	(w/h/d)	mm	1000/1425/940	1300/1425/940	1600/1425/940	1900/1425/940
Minimum door opening	(d)	mm	770 (window frame and back panel dismantled)			
	(d)	mm	810 (control unit dismantled)			
Adjustable support frame⁵⁾						
Dimensions of support frame ³⁾	(w/h/d)	mm	1002/680±20/800	1302/680±20/800	1602/680±20/800	1902/680±20/800
Working height		mm	785 ± 20	785 ± 20	785 ± 20	785 ± 20
Weight	Unit	kg	approx. 225	approx. 250	approx. 300	approx. 320
Technical verification						
Exhaust air/fresh air supply volume		m ³ /h	~360	~480	~590	~710
Air circulation volume		m ³ /h	~840	~1100	~1380	~1660
Total re-circulated air volume		m ³ /h	~1200	~1580	~1970	~2370
Holding power						
at 25 °C room temperature		kW	~0.45	~0.45	~0.75	~0.75
Heating up to approx.10 K above room temperature with window closed						
Filter technology						
Air circulation/exhaust air filter	type		H 14 HEPA (in acc. EN 1822)			
Additional AEF	filtering efficiency		99.999% at 0.3 µm particles			
(multi features, HS only)	Class DIN 24 184		better than class S			
Prefiltern (HSP models only)	EN 1822		H 14	H 14	H 14	H 14
ULPA filter, Class H 14 in accordance with DIN 24 183-1						
Noise (in accordance with DIN 12 950)						
Noise pressure level		dB (A)	<60	<60	<60	<60
Lighting power		lx	> 1000	> 1000	> 1000	> 1000
Electrical data						
Voltage ²⁾		V	1/PE AC, 230	1/PE AC, 230	1/PE AC, 230	1/PE AC, 230
Frequency		Hz	50	50	50	50
Power consumption		kW	0.75	0.75	1.3	1.3
Current		A	3.3	3.3	5.7	5.7
Protection class			I	I	I	I
Type of protection			conductor connection			
Protection type			IP 20			
Indiv. precautions on customer side			Lead fuse (slow blow) T 16 A or circuit breaker B 16. The electrical regulations valid in the country of use as well as the relevant connection conditions must be observed.			
Protected electrical outlets in work chamber			230 V, T5A Each outlet can bear a load up to 5 A and is selectively protected with T 5 A fuses. When all outlets are used simultaneously, they must not exceed the maximum total load of 5 A.			
Radio interference			Circuit is interference free in accordance with EN 55 014			

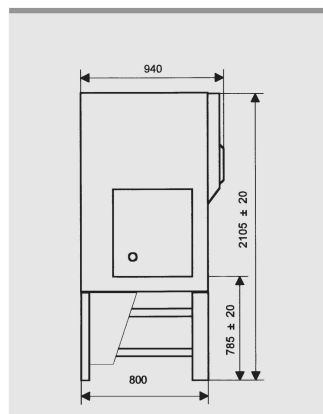
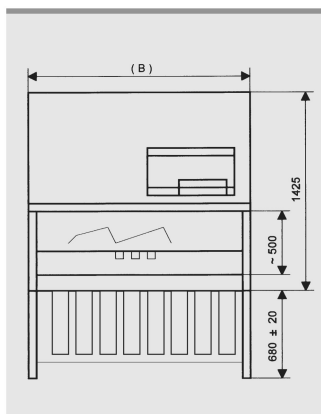

- 1) Further dimensions on request
- 2) Further voltages on request
- 3) Further support frames on request
- 4) Equipment, prefilter unit and support frame are delivered individually. Installation and assembly on-site.
- 5) Standard type FS 12

HERASafe HSP/HSPC overview of dimensions

WE ARE ONLY SATISFIED IF YOU ARE



Our service:
a reassuring feeling

Above average

Kendro provides quick responses to customer needs and competent solutions to problems – wherever in the world you are. Our extensive range of services encompasses far more than just repairs and maintenance work.

Individual

You will notice this, for example, in the quality of our advice - which is individually geared towards customer requirements and problem solving. Our convincing solutions are tailored to guarantee efficient working conditions.

Around the clock

Experienced safety cabinet specialists will quickly and competently help you within the bounds of our wide ranging service network. For instance, via a maintenance agreement with a 24-hour service contract – even at weekends and during bank holidays.

Perfect logistics

On request, all HERAsafe equipment will be delivered where it is needed: directly to your place of work. This service includes, of course, competent set-up and installation.

Comprehensive

Whether it is calibration, reference measurement, application advice, the exchange of spare parts or repairs – our service engineer in your area will be on his way to help you as soon as he receives your call. Fast, committed and without red tape.

All things considered: It's a good feeling to know that Kendro is by your side – working in your interest, and for your benefit.

Your Sales Contact

For Ordering or Technical Information

Australia	Kendro Laboratory Products Pty Ltd · Lane Cove, Sydney · NSW 2066 · Tel. +61 (0) 2-9936 1540 · Fax +61 (0) 2-9427 9765 · info@kendro.com.au
Austria	Kendro Laboratory Products GmbH · Vienna · Tel. +43 (0) 1-801 40 0 · Fax +43 (0) 1-801 40 40 · office@kendro.at
Canada	Kendro Laboratory Products International Sales · Newtown, CT · USA · Tel. +1 203-270 2080 · Fax +1 203-270 2166 · info@kendro.com
China	Kendro Laboratory Products Beijing Rep. Office · Beijing · Tel. +86 (0) 10-6501 3810 · Fax +86 (0) 10-6501 4229 · kendrobj@163bj.com Kendro Laboratory Products (H.K.) Limited · Hong Kong · Tel. +852 2711 3910 · Fax +852 2711 3858 · info@kendro.com Kendro Laboratory Products Shanghai Rep. Office · Shanghai · Tel. +86 (0) 21-5490 0216 · Fax +86 (0) 21-5490 0230 · kendrosh@public4.sta.net.cn
Denmark	Axeb AB · Albertslund · Tel. +45 (0) 43-6246 47 · Fax +45 (0) 43-6246 41 · info@axeb.dk
France	Kendro Laboratory Products SAS · Courtaboeuf cedex · Tel. +33 (0) 1-69 18 77 77 · Fax +33 (0) 1-60 92 00 34 · info@kendro.fr
Germany	Kendro Laboratory Products GmbH · Hanau · Tel. +49 (0) 1805-536 376 · Fax +49 (0) 1805-112 114 · info@kendro.de
India	Kendro Laboratory Products (India) Pvt. Ltd. · New Delhi · Tel. +91 (0) 11-26 18 48 40 · Fax +91 (0) 11-26 18 53 97 · kendro.india@vsnl.com
Italy	AHSI S.p.A. · Cornate D'Adda · Tel. +39 039-68 271 · Fax +39 039-68 27 500 · info@ahsi.it
Japan	Nippon Kendro Co. Ltd. · Tokyo · Tel. +81 (0) 3-3517 1661 · Fax +81 (0) 3-3517 1664 · info@kendro.co.jp
New Zealand	Kendro Instruments New Zealand · Auckland · Tel. +64 (0) 9-525 03 33 · Fax +64 (0) 9-525 03 37 · info@kendro.co.nz
Poland	Kendro Spółka z.o.o. · Warsaw · Tel. +48 (0) 22-663 43 23 · Fax +48 (0) 22-663 43 25 · kendro.warszawa@kendro.com.pl
Portugal	Heraeus S.A. · Massamá · Tel. +351 (0) 214-387 630 · Fax +351 (0) 214-387 636 · heraeus@mail.telepac.pt
Spain	Heraeus S.A. · Madrid · Tel. +34 (0) 91-358 19 96 · Fax +34 (0) 91-358 20 67 · laboratorio@heraeus.es
Sweden	Axeb AB · Sollentuna · Tel. +46 (0) 8-585 777 50 · Fax +46 (0) 8-623 15 45 · info@axeb.se
Switzerland	Kendro Laboratory Products AG · Zurich · Tel. +41 (0) 1-454 12 12 · Fax +41 (0) 1-454 12 99 · kendro-ag@swissonline.ch
U.K./Ireland	Kendro Laboratory Products SA · Carouge (Geneva) · Tel. +41 (0) 22-343 21 67 · Fax +41 (0) 22-342 38 31 · kendro-sa@swissonline.ch
USA	Kendro Laboratory Products PLC · Bishop's Stortford · Herts · Tel. +44 (0) 1279-827 700 · Fax +44 (0) 1279-827 750 · kendro@kendro.co.uk Kendro Laboratory Products · Newtown, CT · Tel. +1 800-522 7746 · Fax +1 203-270 2166 · info@kendro.com
All other countries in	
Asia Pacific	Kendro Laboratory Products (H.K.) Limited · Hong Kong · Tel. +852 2711 3910 · Fax +852 2711 3858 · info@kendro.com
Europe, Middle East, Africa	Kendro Laboratory Products International Sales · Hanau · Germany · Tel. +49 (0) 1805-536 376 · Fax +49 (0) 1805-112 114 · info@kendro.de
Latin America	Kendro Laboratory Products International Sales · Newtown, CT · USA · Tel. +1 203-270 2080 · Fax +1 203-270 2210 · info@kendro.com
Internet	http://www.kendro.com



Quality Products – Lifetime Care

Heraeus

Registered to ISO 9001. Kendro Laboratory Products meet or exceed stringent quality and product safety standards.
©2003 Kendro Laboratory Products. All Rights Reserved.

Printed in Germany 2C 02/03 4t Frotzschler – 209101-1