



Hand Held Auto Refract Keratometer

Retinomax K-plus 3

Instructions



CAUTION Please read this instruction manual before using the instrument.

This instruction manual is intended for users of the Righton Retinomax K-plus 3.

It includes instructions on how to use the instrument, safety handling precautions, and specifications.

These instruments conform to the Japanese Industrial Standards (JIS) as well as the standards of the International Electrotechnical Commission (IEC).

Before using the instrument be sure to read the instructions carefully, and fully understand the operation procedures and safety instructions to ensure correct usage. Also, please keep this manual near the main unit so that you can refer to it whenever necessary.

If you have any questions or comments, please do not hesitate to contact the dealer from whom you purchased the instrument.

- No part of this manual may be reproduced or transmitted without permission.
- The information in this manual is subject to change without prior notice.

CONTENTS

■ Handling Precautions -- Please first read for safety purposes	4
■ Labels and Marks	8
1. Overview	11
1-1 Instrument Overview, Standard Accessories and Options	11
1-2 Instrument Classification	13
1-3 Symbols on the Instrument	14
2. Names of Parts	15
2-1 Main Unit	15
2-2 Station	17
2-3 Printer	18
3. Setup	19
3-1 Attaching/Detaching the Strap	19
3-2 Installing and Removing the Battery Pack	19
3-2-1 Installing and Removing the Main Unit Battery Pack	19
3-2-2 Installing and Removing the Printer Battery Pack	20
3-3 Setting Up the Instrument	21
3-4 Charging the Battery Pack	22
3-4-1 Automatic Charging of the Main Unit	23
3-4-2 Automatic Charging of the Printer	23
3-4-3 Charging a Spare Battery Pack	24
3-5 Power Supply from the Station	24
3-6 Confirmation of Configuration	25
3-7 Measuring the Model Eye	26
4. Measurement Procedures	27
4-1 Measurement Screen	27
4-2 Before Measurement - Explanation for the Patient	28
4-3 Measurement Modes and R Modes	29
4-4 Automatic Measurement Mode	30
4-5 Continuous Measurement Mode	35
4-6 Quick Measurement Mode	36
4-7 Keratometric Peripheral (PERI) Measurement	38
4-8 Helpful Hints for Successful Measurement	39
4-8-1 Others: Considerations for Measurement	43
4-8-2 Battery Low Indication	46
5. Various Functions	47
5-1 Pupil Diameter Measurement Function	47
5-2 Alignment Direction Indication Function	48
5-3 Horizontal Indication Function	49
5-4 Auto Quick Function	50

5-5	Memory Function	52
5-6	Retroillumination Mode	60
6.	Printing Out Stored Data	61
6-1	For Wireless Communication	61
6-2	For Wired Connection	62
6-3	Sample Printouts (When KER PRINT Is Set to ALL for Keratometric Measurement)	63
6-4	Printout (Multiple Printers)	65
6-4-1	Using Multiple Printers	65
6-4-2	Changing the Print Format	66
7.	Setting Up the Instrument	67
7-1	SETUP Screen	68
7-2	SET-MENU Screen -- Measurement Setup	69
7-3	HOLD MODE Screen -- Mode Store/Setup	70
7-4	OUTPUT Screen -- Output Setup	71
7-5	PRINT Screen -- Print Setup	73
7-6	RS232C OUTPUT Screen -- External Output Setup	74
7-7	CLOCK Screen -- Time Setup	75
7-8	NO. Screen -- Patient Number Setup	76
7-9	MESSAGE Screen -- Message Input	77
8.	Connecting to the Remote Vision and a Computer	78
9.	Maintenance	80
9-1	Checking the Measurement Accuracy	80
9-2	Replacing the Print Roll	80
9-3	Replacing the Fuses	81
9-4	Cleaning the Forehead Rest	81
9-5	Cleaning the Measuring Window	82
9-6	Cleaning the Model Eye	82
9-7	Appearance Maintenance	82
9-8	List of Consumable and Maintenance Parts	82
10.	Troubleshooting	83
11.	Specifications	87
	Authorization to apply the UL mark	90
	Information on the avoidance of overexposure to optically hazardous optical radiation	91
	Patient environment	93
	Information of EMC	94

■ Handling Precautions -- Please first read for safety purposes.

< Caution Symbols Used in This Manual >

Righton products are manufactured with full attention to safety. However, these instruments can cause personal injury or equipment damage if used improperly or if the instructions are ignored. For your own safety, read this instruction manual carefully and thoroughly before using the instrument. Do not discard this manual, but keep it handy for easy reference.

This manual uses the following symbols to draw your attention to "important safety instructions." Be sure to follow the instructions marked with these symbols.

Symbol Meaning



CAUTION:

Indicates a potentially hazardous situation which, if not avoided, could result in injury or damage to the surrounding equipment.



CAUTION

1. Intended product use

- The Retinomax K-plus 3 is only intended to be used for measuring refractive power, corneal curvature and pupil diameter. Do not use it for any other purpose.



CAUTION

2. Do not disassemble

- Never attempt to disassemble the product as it could cause a serious electric shock or equipment damage.



CAUTION

3. Measuring operation

- When moving the main unit toward the patient or laterally in front of the patient, use care to avoid hitting the patient's face.



CAUTION

4. Installation and transport

- Do not place the instrument on an unstable location, such as a shaky table or inclined surface. It could be dropped or fall and cause injury.
- Hold the main unit using the grip. Do not hold it with the viewfinder or forehead rest.
- Place the station and printer in a well-ventilated location. Do not place thick cloth or paper under the station or printer, as it may prevent the release of heat during battery charging. If the vent hole is blocked, heat will accumulate

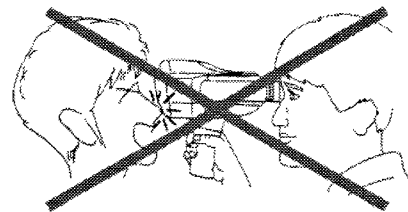

internally, leading to the danger of fire or failure.

- The operating environment should be between 700hPa to 1060 hPa in atmospheric pressure, 10°C to 40°C in temperature, and 30% to 75% in humidity.
- Although the instrument is designed with dust protection, it should not be used in a dusty room.
- The best location for the instrument is a room equivalent to a semi-dark room. Do not expose the instrument to a bright window or illumination light.
- The instrument conforms to the EMC standard (IEC60601-1-2:2001), but discharges weak radio waves. If the instrument in operation interferes with other equipment, such as a TV or radio, take appropriate action, such as increasing the distance between the instruments or changing each direction.
- This instrument is not waterproof. It should not be used or placed in a place where it can be exposed to liquid such as rainwater, beverages or chemicals.
- If dew condensation occurs, allow the dew to disappear before using the instrument.
- When transporting the instrument, protect against vibration and shock, preferably by placing the instrument in the optional carrying case or a packing box.



5. Other handling precautions

- Make sure that the power cord is not damaged, broken, machined, exposed to excessive force (bend, pull, or twist), or twisted with other cords. Do not put heavy objects on, or apply heat to, the power cord, as the cord can be severed, possibly leading to a fire or electric shock. If the power cord is damaged, replace it.
- If dust accumulates on the metal part of the power plug, pull out the power plug and remove the dust. Dust or dirt can cause contact failure of the power plug, resulting in a fire.
- Connect the instrument to a grounding-type receptacle outlet in a manner that meets the power supply specifications. Improper connections can affect the performance, or even cause failure, leakage, shock, or fire.
- Fully insert the power plug. Insufficient insertion can cause a fire.
- When replacing the fuse in the station (p.81), be sure to turn off the power switch and pull out the power cord. Be sure to use the designated fuse. Use of an undesignated fuse can lead to electric shock or fire.
Designated fuse: Littelfuse's time-lag fuse, $\phi 5 \times 20$ mm
250 V, 500 mA (218.500XP)
- Never short-circuit the battery charging contacts of the main unit, station, or printer. If the contacts are short-circuited, the fuse of the station or printer will blow.

- Do not expose the connectors or battery charging contacts to your body or metal objects. If a contact is dirty, turn the power off and wipe the contact off with a dry, soft cloth.
- This product is precision optical equipment, containing a large number of electrical components. Handle with care, avoiding exposure to physical shock.
- Do not drop or bump the instrument. When handling the main unit, always use the supplied strap. Do not swing the main unit holding only the strap.
- If the instrument ceases to function, pull the power cord from the receptacle outlet, and without accessing the inside of the instrument, contact your dealer.
- Use the designated print roll. Use of an undesignated brand can lead to failure.

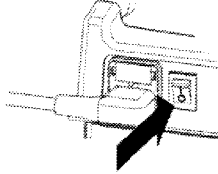

6. Maintenance/Storage

- The environmental requirements for transport and storage are -40°C to $+70^{\circ}\text{C}$ in temperature and 10% to 95% in humidity.
- Select a storage area exposed to limited amounts of dust, free of vibration and shock.
- When cleaning the glass in the measuring window, be careful not to scratch or break the lens. (p. 82)
- After use, turn off the power switch of the station and put on the dust cover. 
- If you plan to put the instrument out of service for a long time, pull the power cord out from the receptacle outlet. Also, remove the batteries from the main unit and keep them for later use. There is a danger of fire if the power cord is left in the receptacle outlet for a long time or the battery is left unremoved for a long time.
- Make sure that when the batteries are in storage, their contacts are not touched by metals, etc. If they are short-circuited to a metal, heating or even a fire can occur.



7. Battery pack

- You should use the RT-121 battery pack, which uses our designated lithium ion battery. Use of any other battery pack voids the operation warranty.
- Carefully read the instructions shipped with the battery pack before using the battery pack.
- Never disassemble or modify the battery pack.
- To recharge the battery pack, always use the station or printer.
- Never short-circuit the terminal of the battery pack. Otherwise, heating may occur, leading to burn injury or a fire. Also, keep metals (coins, paper clips, etc.) away from contact with the terminal area.

- Do not use the battery pack of this product with any other product.
- When charging the battery pack, do not place any cover over the main unit, station, or printer. If a cover is used, the heat generated in the main unit, station, or printer during charging may cause fire. In addition, the service life of the battery pack will be reduced by the additional load due to such a cover.
- Do not expose the battery pack to an intense heat source or flames. Explosion, electrolyte leakage, or fire can occur.
- Do not leave the battery pack in a sun-heated car with the windows closed, or in any location that may be exposed to intense sunlight.
- Do not let the battery pack be exposed to strong impact or drop it.
- If the metal terminals of the battery pack are dirty, wipe them off with a dry, soft cloth.
- If you plan to put the instrument out of service for a week or longer, take the battery packs out of the main unit and printer.
- The battery pack is a consumable item. It can be recharged, but eventually wears out. When the battery pack is no longer usable, purchase a new one from your local dealer of the instrument.



CAUTION

8. Disposal instructions

- Follow local regulations concerning disposal and recycling.
For lithium ion batteries, in particular, observe the specific disposal methods stipulated by your local government.
We recommend entrusting disposal to a designated industrial waste disposal firm.
- When disposing packagings, sort them by material, and then follow the local regulations and plans concerning disposal and recycling.

Symbol for separate collection in European countries

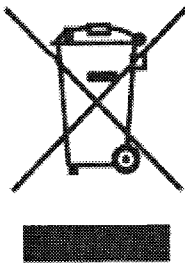

Products bearing this symbol must be collected separately. The following rule is applicable only to users in European countries.

- This product is designated as an item to be collected separately at an appropriate spot. Do not dispose of it as household waste.

For further information, contact the retailer or the local authorities responsible for waste management.

■ Labels and Marks

The product includes labels and marks to draw user's attention to important information and precautions.

If any of the labels are peeled or the characters or marks are illegible, please contact your dealer.

● Bottom of main unit

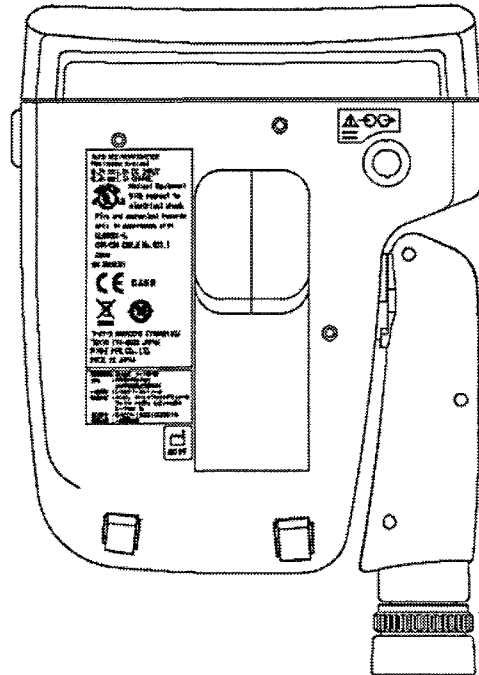
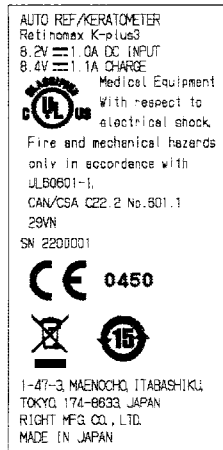

● Inside the grip

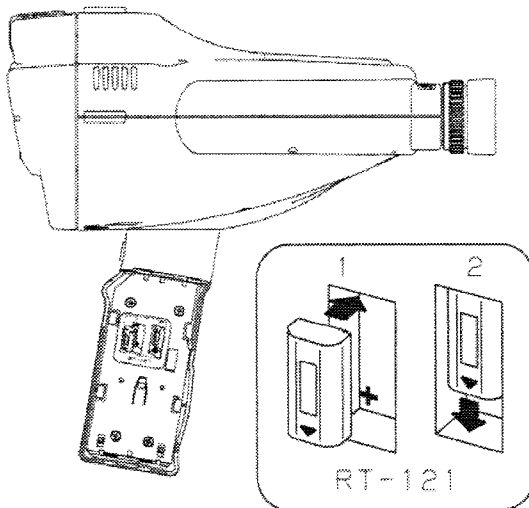

● Type B attachment

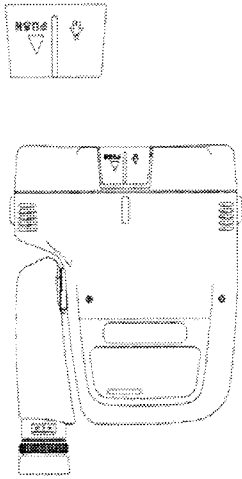

● Rear of the station

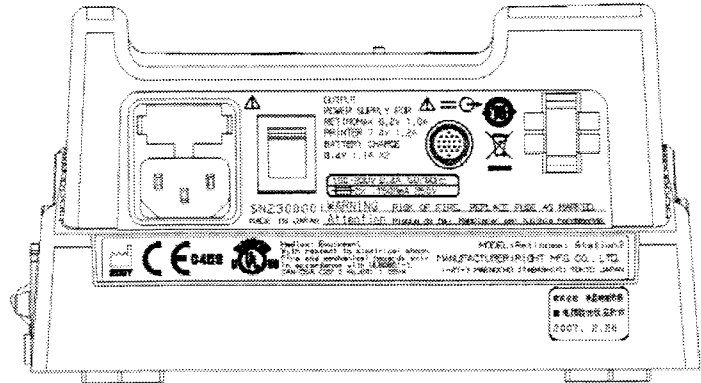

● Side of the printer

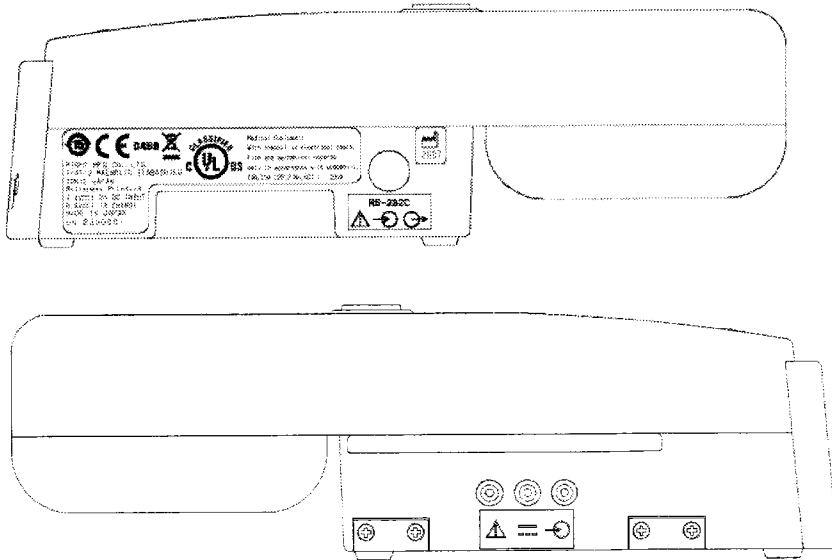

● Top surface of the printer

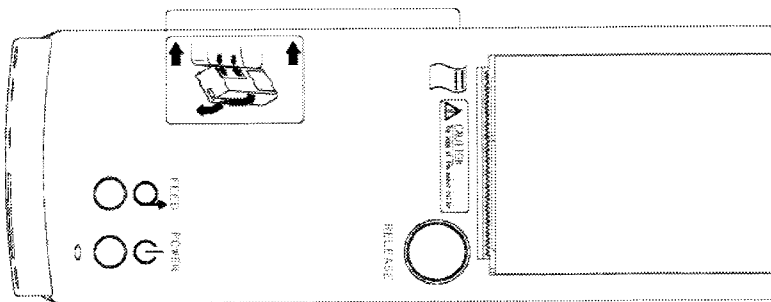

● Bottom of the printer

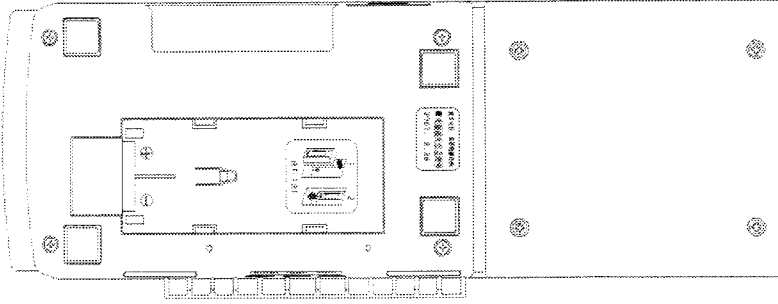

● Bottom of the battery pack

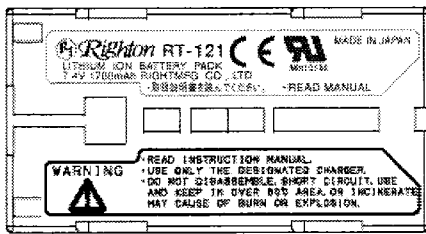

● Recycle mark on battery pack

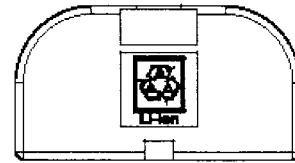

1. Overview

1-1 Instrument Overview, Standard Accessories and Options

The Retinomax K-plus 3 is an objective refractometer, designed to measure refractive power, corneal shape and pupil diameter.

The refractive power measurement examines the refractive condition of the patient's eye to measure the spherical diopter power, cylindrical power, and cylinder axis angle. During the corneal shape measurement, the corneal radius of curvature, principal meridian direction, and corneal astigmatism power are examined.

This instrument consists of a main unit (Retinomax K-plus 3), station (Retinomax station 3), and printer (Retinomax printer 3).

The station contains a battery charger and power supply, which enable the main unit and printer batteries to be charged, and for power to be supplied to the main unit using an optional DC cord. The printer may contain a battery, which facilitates data transfer from the main unit to the printer, thus requiring only a small space for performing a series of operations from measurement to printing.

In addition, the instrument can send data to a computer or other external device.

■ Standard accessories

● Main unit (1)

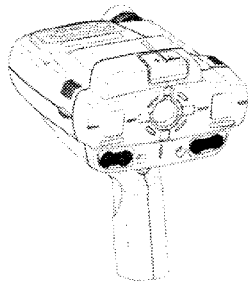

● Station (1)

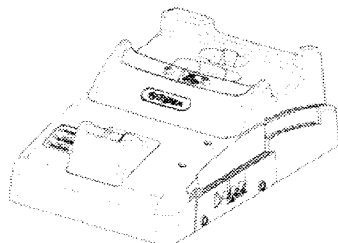

● Printer (1)

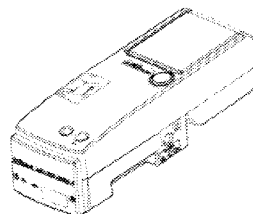

● Battery pack (1)
(5)



● Model eye (1)



● Print paper rolls

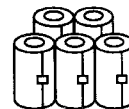

● Strap (1)



● Blower (1)



● Contact lens holder (1)

● Power cord set (1)

● Fuses (2) $\phi 5 \times 20$ mm
250 V, 500 mA (218.500XP)

● Instruction manual (1)

● Dust cover (1)

■ Options

● DC cord

Main unit - Station



This cord is for connecting the station and the main unit, allowing use of the main unit without batteries as the power is supplied to the main unit from the station.

● Direct communication cable

Main unit - External equipment

Connector on external equipment: D-sub 9-pin or D-sub 25-pin

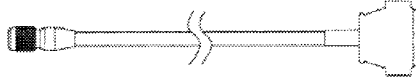

This cable is for connecting the main unit and external equipment. The cable can be used for transferring data to PCs or other devices. To connect to the remote vision, use the D-sub25pin.

● Direct print cable

This cord is for connecting the main unit and the printer.

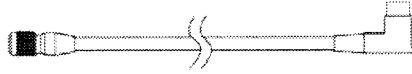

This is the cable for connecting the printer to the main unit. Use this to connect the printer to the main unit to send data directly. Sending data stored in memory to the printer without the direct print cable takes a lot of time, so we recommend use of the cable.

● Video output cable

Main unit - External monitor



This cable is for connecting the main unit and the external monitor. The cable can be used when reading out the data displayed on the view finder onto an external monitor. The output is only NTSC.

● Communication cable

Printer - External equipment

Connector on external equipment: D-sub 9-pin or D-sub 25-pin

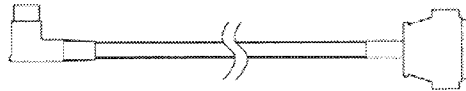

This cable is for connecting the printer and an external device. This cable can be used for transferring data to PCs or other devices through the printer. Use a D-sub25pin to connect to a remote vision.



The DC cord, director communication cable, direct print cable and video output cable are only to be used with the Retinomax 3 and Retinomax K-plus 3. These cables cannot be used for connecting to the Retinomax, Retinomax K-plus, Retinomax 2, and Retinomax K-plus2.

● Battery pack

● Carrying case

1-2 Instrument Classification

< Classification as per 93/42EEC (MDD) >

Class II a

< Protection type against electric shock >

Class I

This instrument is classified as equipment whose protection against electric shock does not rely on basic insulation only, but which includes an additional safety precaution, in that means are provided for the connection of the equipment to a protective earth conductor in the fixed wiring of the installation in such a way that accessible metal parts cannot become live in the event of a failure of the basic insulation. Always use the power cord shipped with the instrument. It must be connected to a receptacle outlet with a ground.

< Degree of protection against electric shock >

Type B attachment

The forehead rest of this instrument is a type B attachment. This instrument is equipped with a reliable safeguard against electric shock, as verified through testing in accordance with the applicable standard for patient leakage current and measurement current.

< Protection against water and particle ingress >

IP20

This instrument is not protected against the ingress of water and other liquids. The instrument should not be exposed to liquids.

< Degree of safety for use in a flammable environment >

Retinomax K-plus 3 is not designed to be used in a flammable environment. Do not use it in a flammable environment.

< Disinfection method approved by the manufacture >

Clean the forehead rest with a cloth soaked in rubbing alcohol whenever necessary.

< Operation mode >

Continuous operation

< Laser classification >

EN60825-1.2:2001 Class I LED product
Wavelength 855 nm to 870 nm
Radiant power 111 μW max

1-3 Symbols on the Instrument



: This symbol on the instrument indicates the need for caution. It indicates the necessity of referring to the relevant part of the instruction manual before use.



: This symbol indicates that the type of protection against electric shock for the applied part is type B.



: This symbol indicates the power button on the operation panel of the main unit as well as on the printer.



: This symbol on the operation panel indicates that this is a correction button for rotating the optical axis of measuring beam in 45-degree steps.



: This symbol on the operation panel of the main unit indicates the button that allows toggling between two values of the brightness of fixation target.



: Represents a connection suitable only for DC power.



: Represents an input.



: Represents an output.



: This symbol on the station indicates the on position of the power switch.



: This symbol on the station indicates the off position of the power switch.



: The lamp indicated by this symbol on the station illuminates while the battery is charged.

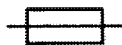

: Represents a fuse.



: Represents a feed button for print paper.



: Represents a print paper outlet.



: This symbol is designed to promote the recycling of used lithium ion battery.

2. Names of Parts

■ System configuration

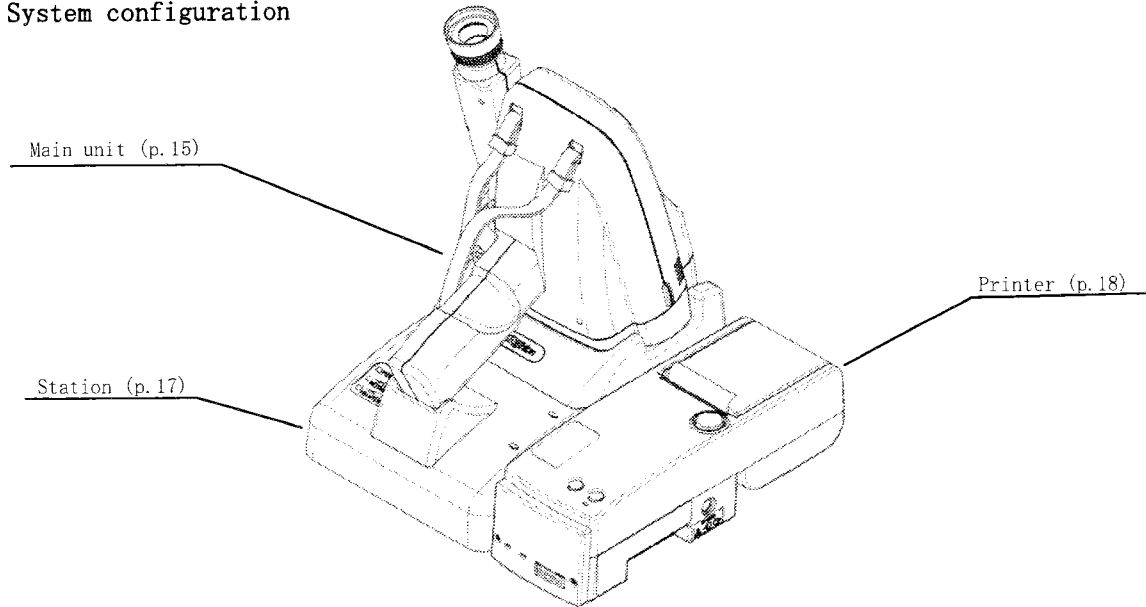

2-1 Main Unit

● Side Facing Patient

Target line for measuring-window lateral position

Used as a marker to align to the horizontal position of the patient. (p. 30)

Forehead rest

Slide in the ▲ direction to slide out the forehead rest. Apply this to the patient's forehead to minimize shaking of the main unit. (p. 40)

Target line for measuring-window height

Used as a marker to align to the height of the patient. (p. 30)

Kerato-center measuring windows (four)

Perform kerato-center measurement through these windows.

Measuring window

The patient looks at the target (p. 28) through this window.

Start switch

Starts and ends the measurement. (p. 30-42)

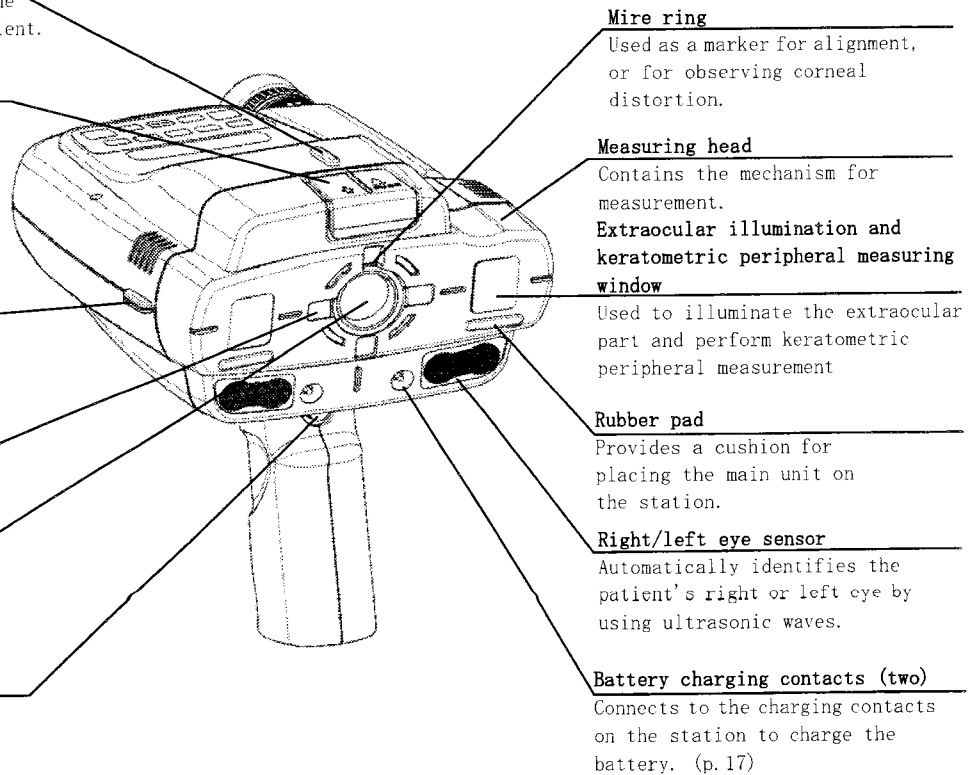

Mire ring

Used as a marker for alignment, or for observing corneal distortion.

Measuring head

Contains the mechanism for measurement.

Extraocular illumination and keratometric peripheral measuring window

Used to illuminate the extraocular part and perform keratometric peripheral measurement

Rubber pad

Provides a cushion for placing the main unit on the station.

Right/left eye sensor

Automatically identifies the patient's right or left eye by using ultrasonic waves.

Battery charging contacts (two)

Connects to the charging contacts on the station to charge the battery. (p. 17)

● Main Unit (Side Facing Operator)

Power/communication connectors

Plug in the DC cord, direct communication cable, and direct print cable (all available as options) to these connectors. Connecting the DC cord to the station enables operation without using a battery. (p.12)

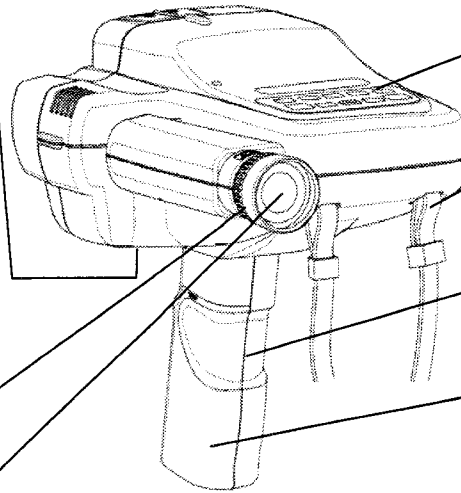

Switch panel

See the figure below.

Strap eyelet

Always use the straps when using this product.

Grip

Grip for handling the main unit.

Grip cover

Remove this when replacing the battery.

Diopter adjustment ring

Allows for adjustment in the range of -8D to +8D.

Viewfinder

Look at the Patient's eye through this viewfinder to achieve alignment for measurement.

● Switch panel on the main unit

PERI key

Used for kerato peripheral measurement. (p.38)

MEMORY key

Used for storing data. (p.52)

Fixation target brightness key

Brightness of fixation target is toggled to H (bright) or L (dark).

POWER key

Turns the power to the main unit on and off. The lamp atop the switch lights when power is turned on.

MODE key

Selects a measurement mode: "Ref only," "Kerato only," or "Ref/Kerato." (p.29)

RETRO/PUPIL key

Used for observation in the pupil and measurement of pupil diameter.

ANGLE key

Used when the main unit is used in a rotated position. Corrects Ax (cylinder axis angle) for the rotation (45°, 90°, or 135°) of the main unit. (p.40)

QUICK (& melody) key

Enters the quick mode. (p.36) A melody sounds after this key is held for more than 1 second. (p.42)

PRINT key

Transfers data to the printer. (p.61)

R/L key

Toggles the right/left eye identification between automatic and manual mode, or in the manual mode, changes between right and left eyes. (p.39)

Use the manual mode when performing measurements with children or patients in a supine position

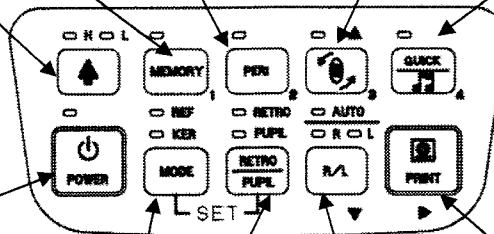

2-2 Station

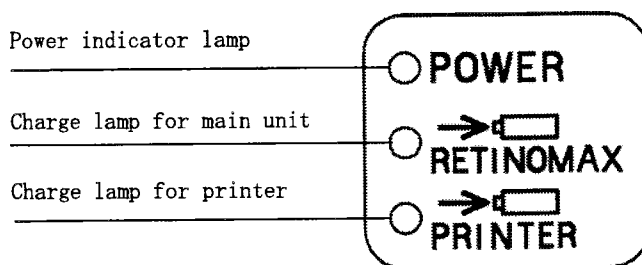
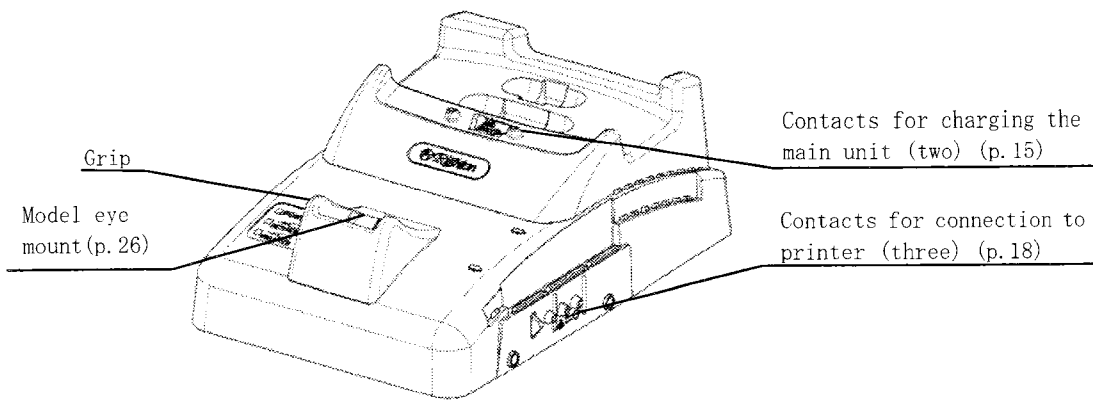

● Station (rear)

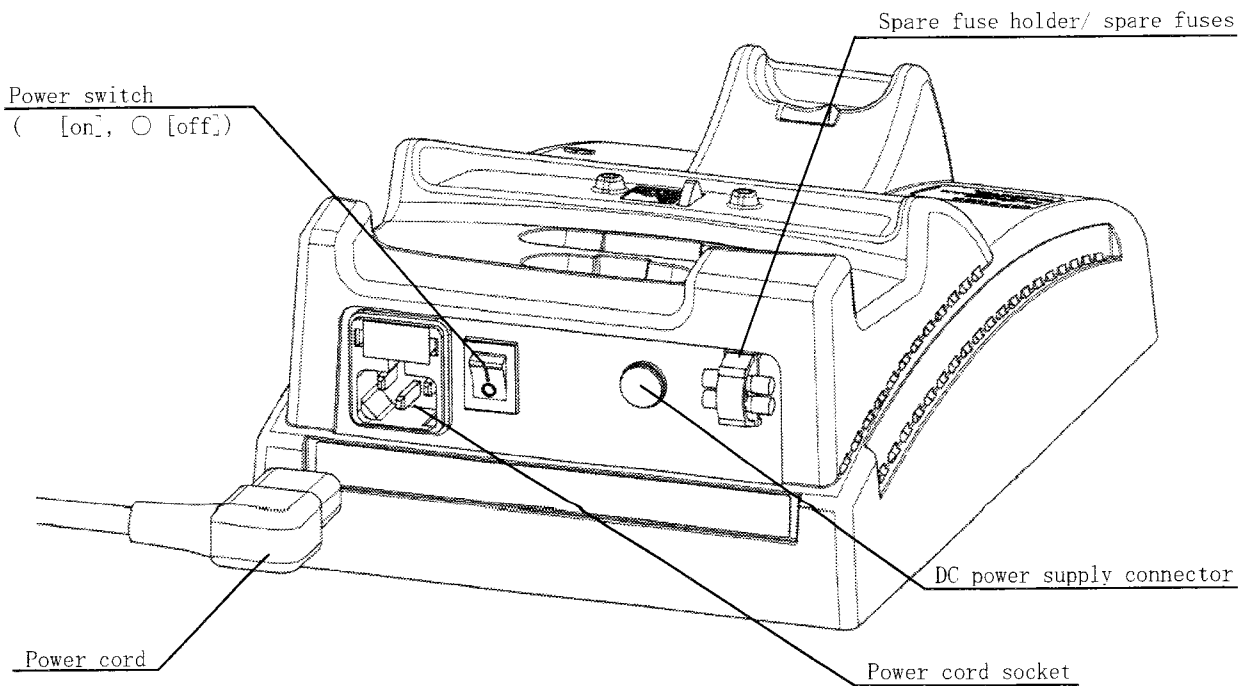

2-3 Printer

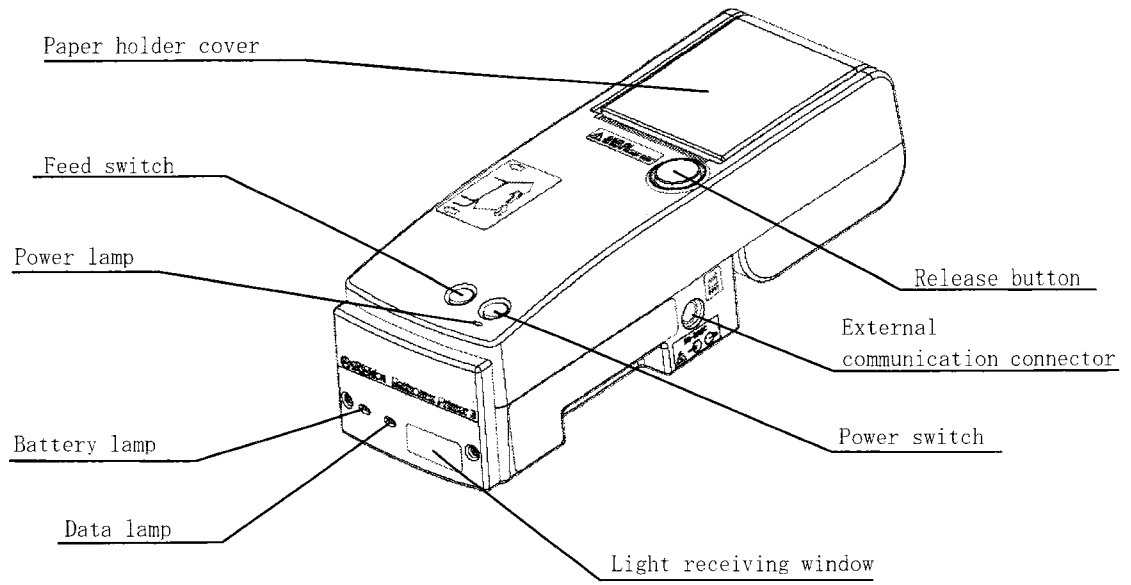

● Printer (bottom)

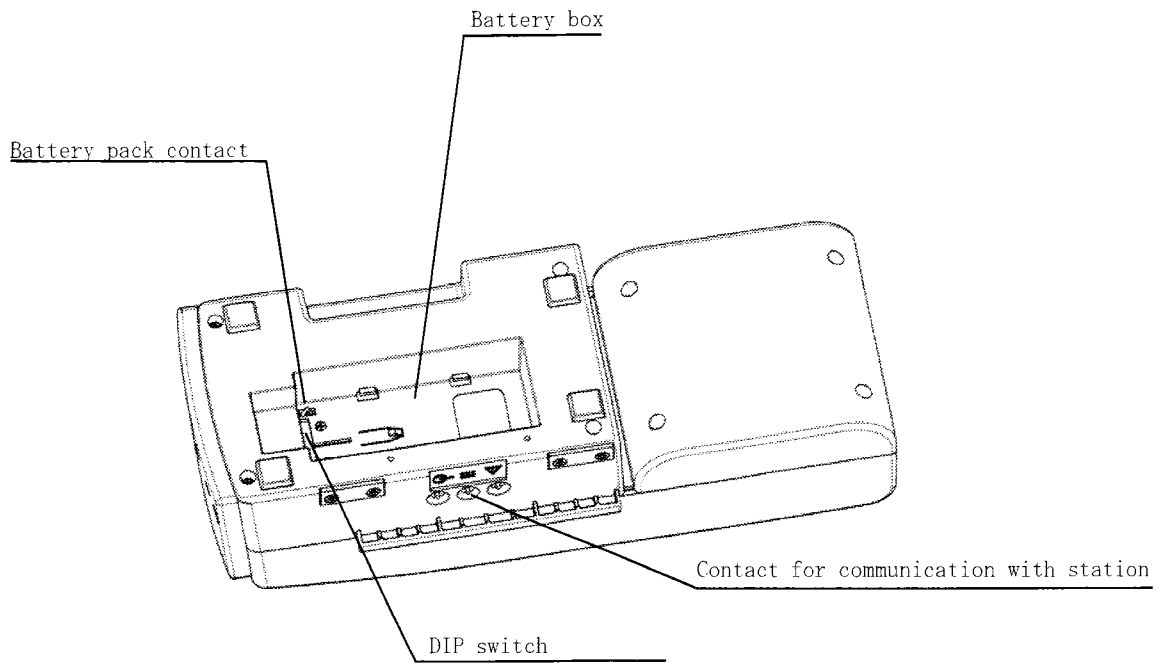

3. Setup

3-1 Attaching/Detaching the Strap

Attach the strap to the eyelets of the main unit.



Attaching the strap 1



Attaching the strap 2



Attaching the strap 3

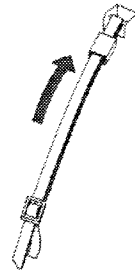

Attaching the strap 4



CAUTION

- When moving the instrument while it is in operation, hang it from your neck using the strap and hold the grip.
- Dropping the instrument may lead to injury or damage
- Ensure that the strap is securely fastened.
- If the strap is damaged, replace it with a new one.

3-2 Installing and Removing the Battery Pack

3-2-1 Installing and Removing the Battery Pack

■ Main Unit Battery Pack

● Replacing the battery pack

1. Open the battery cover over the grip. Do this by pressing with your fingers near the top of the cover in direction ① (Figure 1) and sliding in direction ②.
2. Replace the battery pack.
Remove the battery pack from the grip by sliding it lightly in direction ③ (Figure 2).

Figure (1)

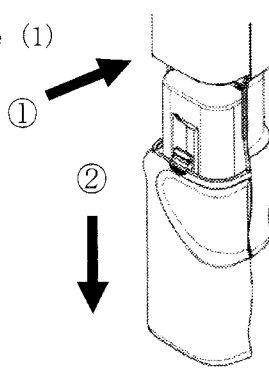
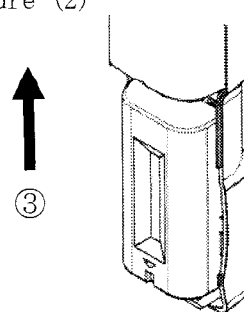

Figure (2)



3. Make sure that the ∇ mark on the battery pack faces direction ④.

Put in place a new battery pack by simultaneously hooking over the four lugs (circled in Figure 3), and then slide in direction ⑤ until the pack is secured in the grip.

Figure (3)

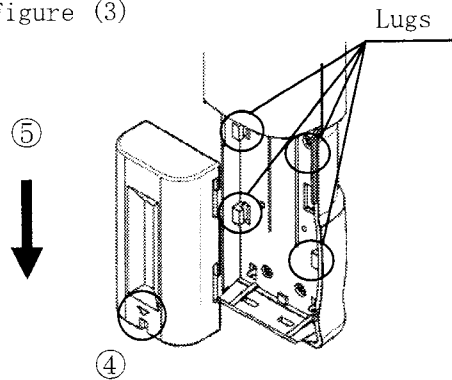
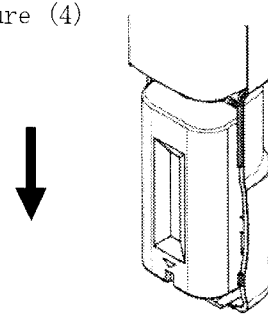

Figure (4)



Battery back being refit

4. Put the grip cover in place by sliding it in the opposite direction from direction ② in Figure 1.

3-2-2 Installing and Removing the Printer Battery Pack

● Replacing the battery pack

The printer can be operated on battery power using the optional battery pack (the same model as in the main unit). It should be charged and set in the battery box of the printer.



The printer is not shipped with a battery pack.

To run the printer on battery power, you must purchase an optional battery pack.

1. Install the battery pack

Make sure that the ∇ mark on the battery pack faces in direction ① (Figure 5).

Put the new battery pack in place by simultaneously hooking over the four lugs (shown circled in Figure 5), and then sliding it in direction ② until the pack is secured in the battery box.

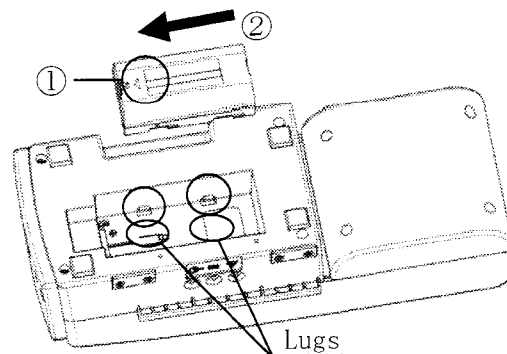

Figure (5)

2. Replace the battery pack.
Remove the battery pack from the battery box by sliding it lightly in direction ③ (Figure 6).

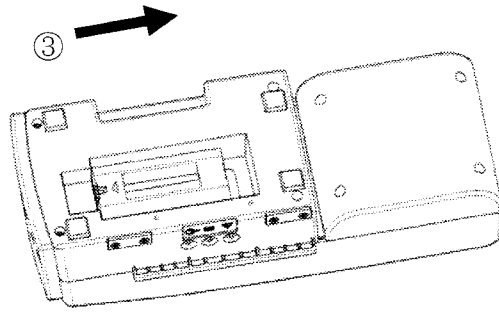
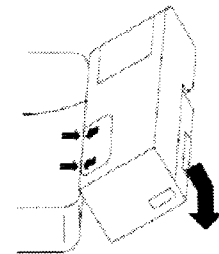

Figure (6)

3-3 Setting Up the Instrument

1. Connect the power cord to the power cable receptacle on the station.
2. Make sure that the power switch on the station is set to OFF ("○" side), and plug the power plug into a power outlet.
3. On the station, set the power switch to ON ("|" side). The power indicator lamp will light.
4. Install the battery pack onto the main unit. (p.19)
5. Mount the main unit on the station and charge the battery pack. (Fully charging the battery from an uncharged state takes about 120 minutes.)
 - When using the battery pack for the first time, be sure to charge it. The battery pack is not charged at the time of purchase.
6. Install the print paper roll onto the printer. (p.80)
7. Connect the printer to the station.
Tilt the printer and align the sticker position on the top left of the printer to the arrows on the top right of the station (see the figure on the right).
8. Turn on the power switches on both the station and printer. Press the feed switch to feed the print paper to an appropriate length.
 - The printer can be operated using the battery pack. (p.20)



3-4 Charging the Battery Pack

Be sure to read the following precautions before starting charging.

■ Charging precautions

- When using the battery pack for the first time
 - First charge the battery pack.
 - The battery pack is not charged at the time of purchase.
 - Carefully read the instructions shipped with the battery pack before use.
- Charging precautions
 - When charging the battery pack, do not place any cover over the main unit, station, or printer. If a cover is used, the heat generated by the main unit, station, or printer during charging may lead to fire. In addition, the additional load due to the covering will reduce the service life of the battery pack.
 - When charging is complete, the battery pack and the grip of the main unit will be warm. This is normal.
 - Once the battery pack is charged, do not recharge it again without operating the instrument, as this will lead to deterioration of the battery. If the battery has sufficient remaining charge, the station will not recharge it.
 - If the charge lamp on the station flashes during charging, there may be a problem with the charging. Follow the steps described later under “Check on Flashing of the Charging Lamp.” (p.84)
 - The main unit or printer can be removed from the station and used before the charging is completed.
- Precautions on contacts
 - The charging may fail if the contacts are dirty.
 - Be careful not to touch the station contacts (recessed parts), main unit contacts (pins on the front of the main unit), and printer contacts (lower pins). Also, do not touch the contacts (plates) of each battery pack.
 - If the contacts are touched or dirty, wipe them clean with a dry cloth.



CAUTION

- Only use the RT-121 battery pack, which is our designated lithium ion battery. Use of any other battery voids the operation warranty.
- Never disassemble or modify the battery pack.
- Never short-circuit the terminal of the battery pack. Otherwise, heating may occur, leading to burn injury or a fire. Also, keep metal objects (coins, paper clips, etc.) away from contact with the terminal area.

3-4-1 Automatic Charging of the Main Unit

To automatically charge the battery pack of the main unit, follow these steps:

1. On the station, set the power switch to ON (“|” side).
2. Place the main unit onto the station. When the main unit is placed onto the station, the power of the main unit automatically shuts off.
3. When the main unit is placed onto the station, the charge lamp lights.

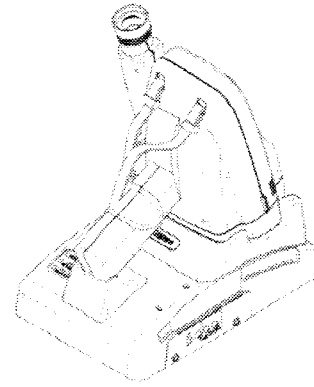

The station automatically determines the capacity of the battery pack in the main unit and decides whether the battery needs charging.

If charging is not needed, the lamp goes out after a few seconds. It continues to be lit if charging is needed. (Maximum charging duration: 120 minutes)

4. When the charging is completed, the charge lamp for the main unit goes out. When the main unit is connected to the station and the power is on, the station will constantly monitor the battery pack level. If the capacity becomes low due to natural discharge, the battery pack will be automatically recharged, keeping it above a certain level.



- Fit the main unit completely on the station. Otherwise, the contacts may not be connected. Also, make sure that the forehead rest is in the stored position; if it is left extended, the main unit will not fit completely.
- Verify that a battery pack is in the main unit.
- When the main unit is capacity of the battery pack is checked and the need for charging is determined, only when the main unit is connected to the station. The battery pack is not constantly checked and charged.
- Charging time varies depending on the age of the batteries, etc.

3-4-2 Automatic Charging of the Printer

To charge the battery pack in the printer automatically, follow these steps:

1. On the station, set the power switch to ON (“|” side).

The printer function can be used while the battery pack is being charged in the same way as while the batter pack is not being charged.

If you only plan to charge the battery pack, turn off the power (“○” side) to the printer.

2. Connect the printer to the station as shown below. Tilt the printer and align the sticker position on the top left of the printer to the arrows on the top right of the station.

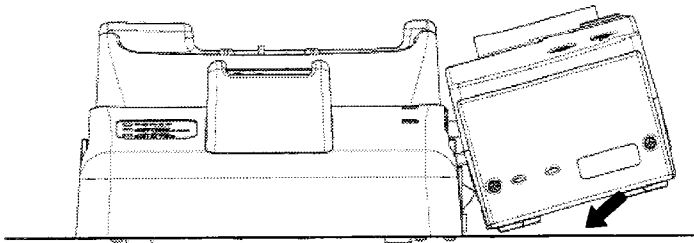

Figure (1)

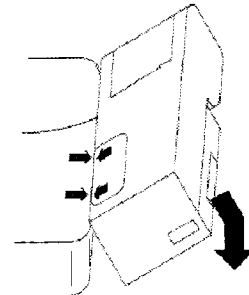

Figure (2)



CAUTION

When connecting a printer to the station, make sure to use the one provided with Retinomax 3 or Retinomax K-plus 3.

Do not use the printer provided with Retinomax, Retinomax K-plus, Retinomax 2 or Retinomax K-plus 2.

3. The printer battery pack charges automatically.
When the charging begins, the printer charge lamp on the station lights up. If charging is not needed, the lamp goes out after a few seconds. It continues to be lit if charging is needed. (Maximum charging duration: 120 minutes)
4. When the charging is completed, the charge lamp for printer goes out.



- Place the station and printer on a flat surface. If placed on an unstable location, the station and printer may not connect properly.
- When the printer is connected to the station and the power is on, the station will constantly monitor the battery pack level. If the capacity becomes low due to natural discharge, the battery pack will be automatically recharged, keeping it above a certain level.
- Charging time varies depending on the age of the batteries, etc.

3-4-3 Charging a Spare Battery Pack

Set the battery pack you want to charge in the battery box of the printer, as described in “3-2-2 Installing and Removing the Printer Battery Pack” (p.20). Follow the same charging procedure described in “3-4-2 Automatic Charging of the Printer” (p.23).

When the charging is complete, remove the battery pack.

3-5 Power Supply from the Station

Using the optional DC cord, the Retinomax K-plus 3 can be operated without battery power.

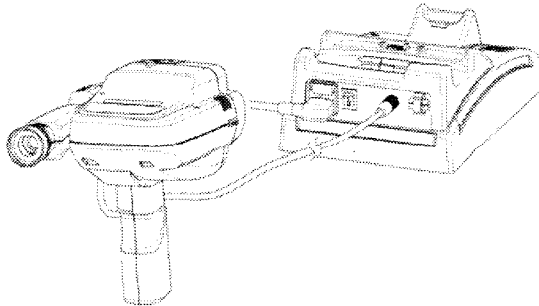

CAUTION

Do not use any other means than our designated DC cord.

3-6 Confirmation of Configuration

The default settings are as follows.

■ Configuration (Measurement Setup Screen)

READING (Measurement mode)	AUTO
CYL	MINUS(-)
VD (Corneal vertex distance)	13.75
BUZZER	ON
INDICATOR (Alignment direction indication)	ON
AUTO QUICK	ON
PARALLEL	ON
PUPIL (Pupil size)	ONE

■ Initialization Configuration (Hold Mode Screen)

QUICK	NORMAL (On initialization, disables the quick mode)
RL SENSE	AUTO (On initialization, enables automatic R/L indication)
R/K MODE	R/K (On initialization, Ref/Kerato mode is enabled)
AX ROTATION	NORMAL (On initialization, disables the axis correction)

■ Output Configuration (Output Setup Screen)

PRT Unit No.	1 (ID number of the main unit)
RV OUT	OFF (Disables infrared communication to remote vision)
PRT RS OUT	OFF (Disables data transmission from the printer's external communication connector)
EDIT MESSAGE	No message is entered

■ Print Setup (Print Setup Screen)

REF PRINT	ALL (Prints all refractive values as measured)
KER PRINT	REP (Only prints representative values of kerato measurement)
PUPIL PRINT	ON (Prints pupil diameter values)
MSG PRINT	OFF (Does not include a message in the printout)
EYE PRINT	OFF (Does not produce an eye print)

■ Configuration of External Output (External Output Setup Screen)

RS232C REF	OFF (Does not transmit data from the main unit's communication cable)
RS232C KER	OFF (Does not transmit data from the main unit's communication cable)
RS232C PUPIL	OFF (Does not transmit data from the main unit's communication cable)

■ Clock Setting (Time Setup Screen)

Date print format (DATE-FORM)	MDY (month/day/year)
Time print format (TIME-FORM)	AM/PM

■ Configuration of Memory Setup (Memory Function Setup Screen)

MEMORY	OFF (Always OFF when power is switched on)
--------	--

3-7 Measuring the Model Eye

Make sure that the model eye and measuring window are not dirty.

If the surface of the measuring window becomes dirty with patients' nose grease or fingerprints or dust, the measurement results may be affected.

If dirty, clean them carefully as described in "9-5 Cleaning the Measuring Window" (p.82) and "9-6 Cleaning the Model Eye" (p.82).

1. Set the model eye on the model eye mount of the station.

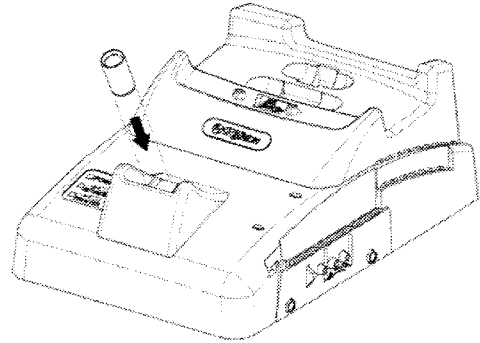

2. Measure the model eye. See Section 4, "Measurement Procedures" (p.27) for measuring instructions.

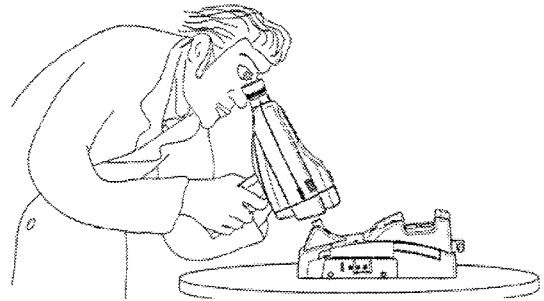

Do not expose the main unit to bright light.

Exposure to light may lead to loss of measurement accuracy or failure of the measurement.

3. Compare the values measured with the model eye against the values (SPH, CYL, R1, R2) printed on the model eye. Confirm that the differences are within the following ranges:

SPH	: $\pm 0.25D$	CYL	: $\pm 0.25D$
R1	: ± 0.02 mm	R2	: ± 0.02 mm

If the measured values are out of the above ranges, see Section 4, "Measurement Procedures" (p.27) and check that your measurement procedure was correct. Then, retry the measurement.

Also check for dirt as described in Section 9-5, "Cleaning the Measuring Window" (p.82) and "9-6 Cleaning the Model Eye" (p.82). If dirty, perform cleaning. If the values still do not fall within the above ranges, contact your local dealer.

4. Measurement Procedures

4-1 Measurement Screen

Make sure that you are finished with the procedures described in “3-3 Setting Up the Instrument” (p.21).

Immediately after you turn on the main unit by pressing  key, the opening screen appears in the viewfinder. It changes to the measurement standby screen after approximately 4 seconds, indicating that the instrument has entered the measurement standby mode.

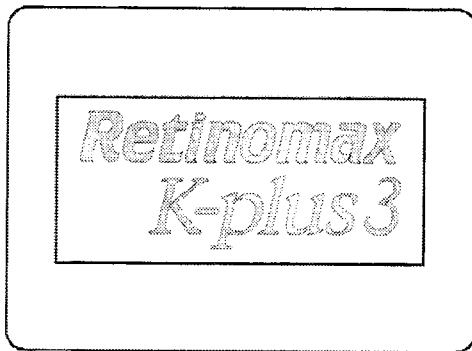

Opening screen when powered on

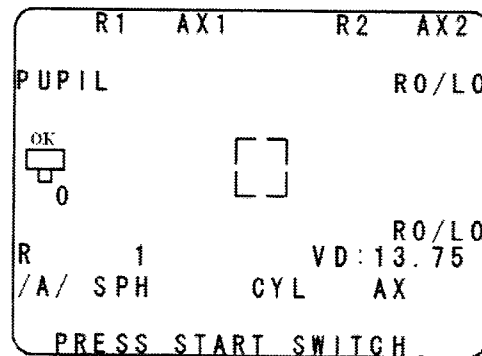

Standby screen in ref/kerato pupil diameter mode

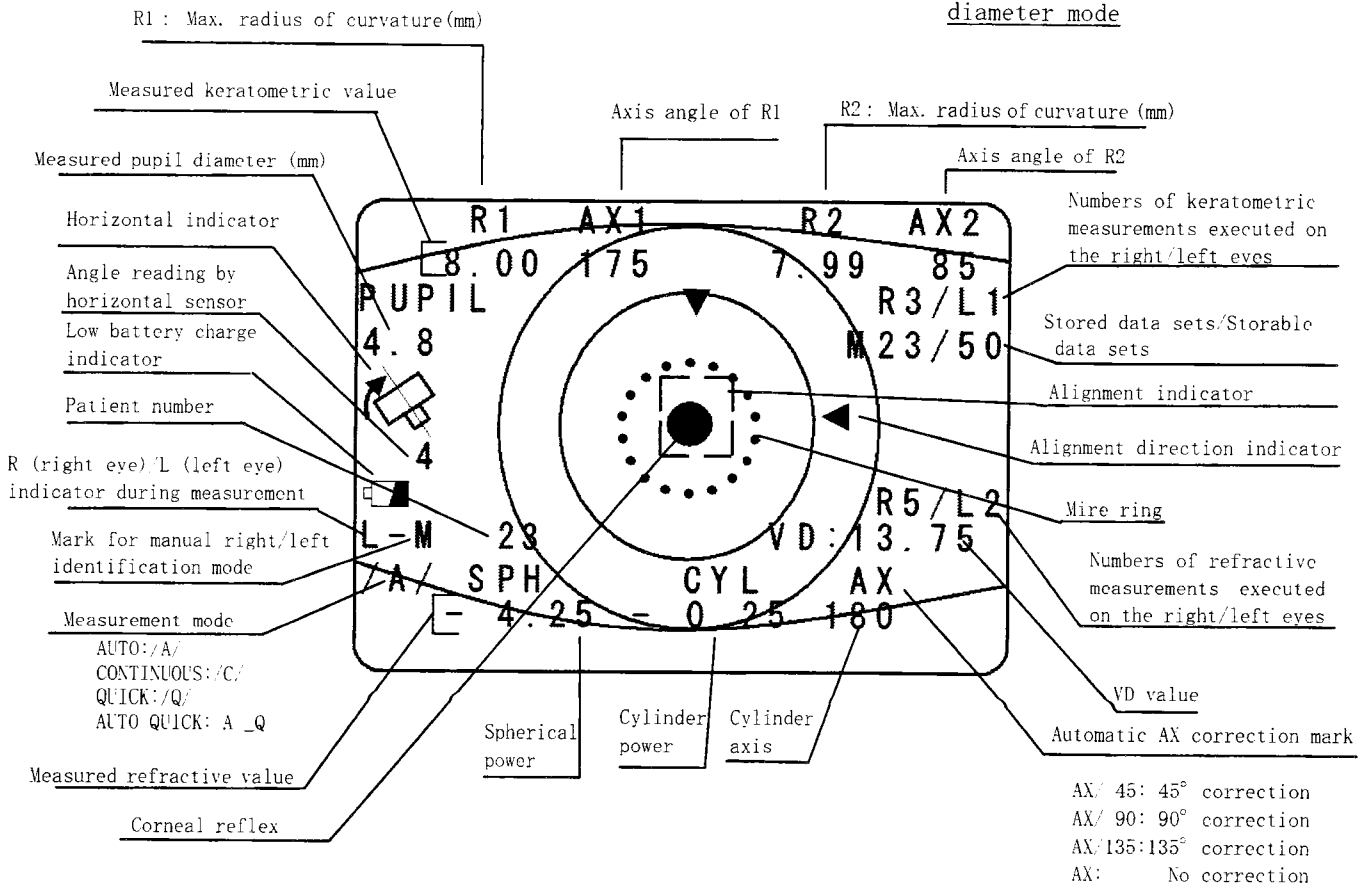

Ref-kerato and pupil diameter measurement screen

4-2 Before Measurement - Explanation for the Patient

Patients tend to be a little nervous, so it is best to try to relax them.

Briefly explain the following:

- “This instrument automatically measures your eyes to determine the spectacle lenses that best suit you.”
- “Please look at the center in a relaxed manner.”
- “Try to keep your eye as still as possible.”

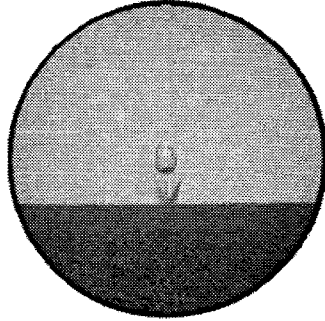

Example of a “tulip” fixation target



When taking a measurement with 90° rotation or from the patient’s vertex, the patient sees the picture rotated by 90° or 180°, respectively.

In a measurement with 45° or 135° rotation, the patient sees the picture tilted diagonally.



CAUTION

When moving the main unit laterally during the measurement, be careful to prevent the forehead rest from hitting the patient’s nose.

(For safety, it is advisable to bring the main unit away from the patient before moving it laterally.)



CAUTION

You may fail to find the eye through the viewfinder, and this can lead to the danger of having the main unit come in contact with the patient. It is important to approximately align the main unit and the patient’s line of sight before looking into the viewfinder.

4-3 Measurement Modes and R Modes



This instrument offers two measurement modes and one R mode.

The measurement mode is selected from "READING" on "7-2 SET-MENU screen" (p. 69).

An R-K mode is selected using  key. Specify "R/K" (Ref/Kerato mode), "R" (Ref mode), or "K" (Kerato mode).

Here, toggle between "AUTO" (automatic measurement mode) (p. 30) and "CONT" (continuous measurement mode) (p. 35).

The following table summarizes the operations for each mode.

<div style="text-align: right;">R-K mode</div> <div style="text-align: left;">Measurement mode (READING)</div>	R-K mode	R mode	K mode
<p>Automatic measurement mode (AUTO)</p> <p>Press the start switch once, place the bright spot within the alignment mark, and focus the mire ring. The measurement will be executed automatically. When the instrument judges that the measurement values are stable, the measurement will end automatically.</p> <p>To print out the measurement data, press  key.</p>	<p>Auto start</p> <p>↓</p> <p>Keratometric measurement (3 cycles)</p> <p>↓</p> <p>Ref measurement (At least 5 cycles)</p> <p>↓</p> <p>When using the pupil diameter measurement function, the pupil diameter is taken after the Ref measurement</p> <p>↓</p> <p>The instrument judges the stability of the measured Ref values & Kerato measurement is performed for at least 3 cycles.</p> <p>↓</p> <p>Auto stop</p>	<p>Auto start</p> <p>↓</p> <p>Ref measurement (At least 5 measurement cycles)</p> <p>↓</p> <p>The instrument judges the stability of measured values</p> <p>↓</p> <p>When using the pupil diameter measurement function, the pupil diameter measurement is taken after the refractive measurement</p> <p>↓</p> <p>Auto stop</p>	<p>Auto start</p> <p>↓</p> <p>Keratometric measurements (At least 3 measurement cycles)</p> <p>↓</p> <p>Auto stop</p>
<p>Continuous measurement mode (CONT)</p> <p>As with the automatic measurement mode, begin the measurement by pressing the start switch. The measurement will not end automatically, but can be interrupted by a press of the start switch. It resumes with another press of the start switch.</p> <p>To print out the measurement data, press  key.</p>	<p>Auto start</p> <p>↓</p> <p>A set of the following measurements in continuous mode</p> <p>Ref/Kerato measurement (a set of 1 measurement cycle each)</p> <p>+</p> <p>When using the pupil diameter measurement function, the pupil diameter measurement is taken after the Ref measurement</p>	<p>Auto start</p> <p>↓</p> <p>A set of the following measurements in the continuous mode</p> <p>Ref measurement</p> <p>+</p> <p>When using the pupil diameter measurement function the pupil diameter measurement is taken after the refractive measurement</p>	<p>Auto start</p> <p>↓</p> <p>Keratometric measurements continues repeatedly</p>

4-4 Automatic Measurement Mode

The automatic measurement mode is the regular mode. The following is a description of the flow of measurements using the automatic measurement mode.

1. On the "7-2 SETUP-MENU Screen" (p.69), set "READING" to "AUTO." (/A/ is shown on the screen.)
2. Press  and select the R-K mode.

The following description assumes that R/K (Ref/Kerato mode) is selected. Settings (refractive measurement and/or keratometric measurement) vary depending on the R-K mode (Ref mode or Kerato mode). See the previous page for specific measurement descriptions for each R-K mode (p.29).

Also, if the pupil diameter measurement function is set to on, the pupil size is measured after a ref measurement. For the pupil diameter measurement function, see "5-1 Pupil Diameter Measurement Function" (p.47).

3. Follow the procedure in "4-2 Explanation to the Patient" (p.28), to relax the patient.

4. Position the patient's eye approximately.
 - Vertical: Align to the target line for measuring window height.
 - Lateral: Align to the target line for measuring window lateral position.
 - Anteroposterior: Position the measuring window approximately 50 mm away from the eye.

Hold the patient's head gently to facilitate anteroposterior positioning.

The positioning can be made still easier by bringing the forehead rest into contact with the patient's eyebrow.

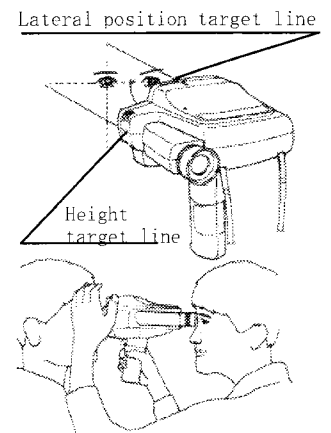

• Be careful not to allow the main unit to touch the patient's eyelashes (p.39).



CAUTION

- When moving the main unit laterally, use care to prevent the forehead rest from hitting the patient's nose.
(For safety, it is advisable to bring the main unit away from the patient before moving it laterally.)

- With the patient's eye positioned approximately, look into the viewfinder during the measurement. When the patient's eye appears on the screen, align the image of the pupil to the center of the screen.

Next, move the main unit back or forth until the image of the dots of the mire ring appears clearly. You can also use the "5-3 Horizontal Indication Function" (p.49) to maintain the horizontal position of the main unit.

As you move the main unit closer to the patient, the automatic right/left eye identification function begins. The screen now looks like the one shown on the right. In the automatic right/left eye identification mode, a beep sounds to indicate that the measurement has changed from the patient's right eye to left eye, or vice versa. As the main unit moves between the right and left eyes, however, the right/left eye identification is unstable, and a continuous beep may sound.

If you find it difficult to properly identify the right/left eyes, refer the section "▼ If the right/left eyes are not properly identified (p.39).

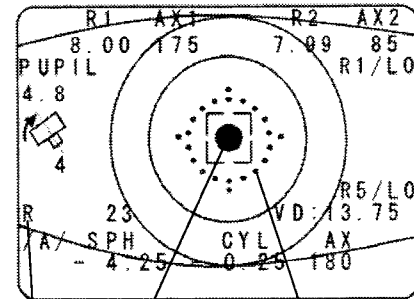

Bright spot Mire ring image
Right/left eye judgment
(R for right, L for left)



The beeping in the automatic right/left eye identification mode is not disabled even if the BUZZER parameter on "7-2 Measurement Setup Screen" (p.69) is set to OFF.



CAUTION

You may fail to find the eye through the viewfinder, and this can lead to the danger that the main unit may come in contact with the patient. It is important to approximately align the main unit and the patient's line of sight before looking into the viewfinder.

- When you press the start switch, the measurement will begin, and data will automatically be obtained when the alignment is correct. (If you find it difficult to achieve alignment, use the "5-2 Alignment Direction Indication Function" [p.48].) You will hear a beeping sound once data is obtained. As starting measurement four bright spots appear on the screen for keratometric measurement, or a single bright spot in the center for refractive measurement. These patterns are repeated in the case of refractive-keratometric measurement.

The automatic fogging function is active during measurement, blurring the fixation target slightly (p.43).



Do not hold the start switch depressed.

7. The measurement results appear on the screen.

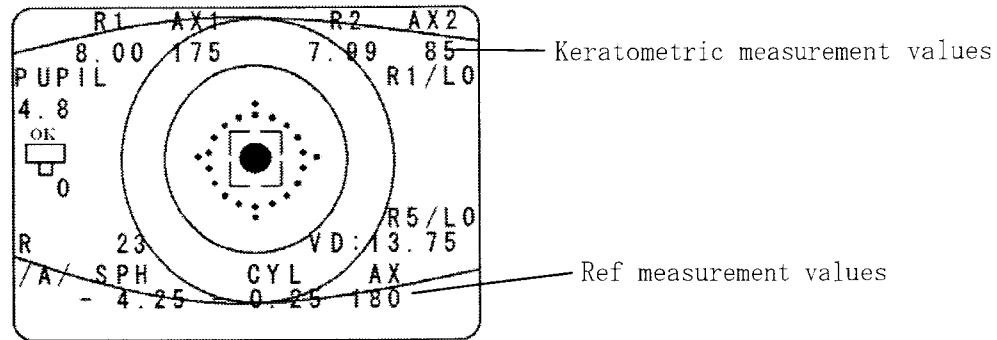

Sample screen during measurement

8. Once started, the measurement can be executed repeatedly. The measurement is interrupted when the start switch is pressed again. The start switch can be pressed once again to resume the measurement beginning from the point just before the interruption.
9. The measurement continues until it automatically ends, with the monitor screen appearing as shown in the figure below. (The figure is an example of a measurement of the right eye.) If you want to remeasure the same eye, press the start switch.

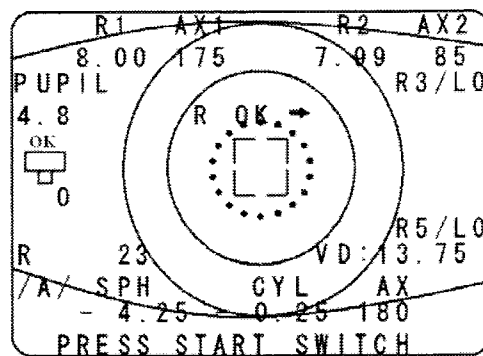

Sample screen at measurement end
(right eye)

10. Perform the same procedure to measure the other eye. The measurement begins automatically, so there is no need to press the start switch. (The figure below is an example of a measurement of the left eye.)

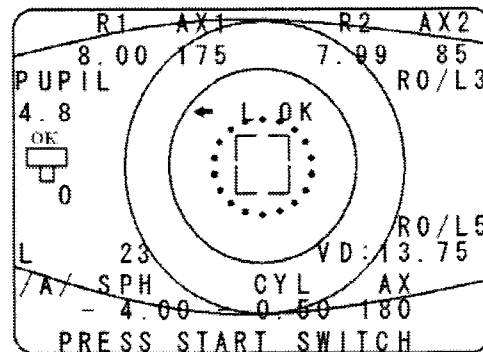

Sample screen at measurement end
(left eye)

- When both eyes are measured, representative values appear in the viewfinder. If you want to continue with the measurement, repeat the procedure from step 4.

```

RL OK!!
PRINT → PRESS PRINT SW

-R- '07 06.28 02:15 PM
SPH:- 4.25 R1 : 8.00
CYL:- 0.25 R2 : 7.99
AX : 180 AX1: 175

-L-
SPH:- 4.00 R1 : 8.00
CYL:- 0.50 R2 : 7.99
AX : 180 AX1: 175
EXIT → PRESS START SW

```

Sample screen after measurement of both eyes

To print out the measurement results for both eyes, aim the front side of the main unit toward the printer and press  (p.61).

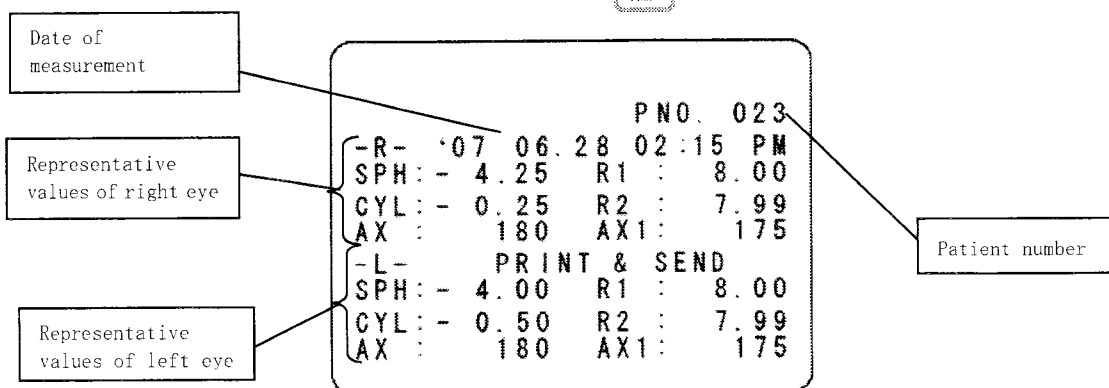

Screen during printing

If you press the start switch without printing out the measurement result, the instrument does not display representative values but returns to the standby screen of Step 4.

If you do not want to take further measurements, carry out the next steps 12, 13 and 14.

- If you used the forehead reset, retract it (p.40).
- Turn off the main unit power. Alternatively, you can put the main unit in place on the station, and the power automatically shuts off.
- Put the main unit back in place on the station.



- If you want to redo measurement on the same patient's eyes, press the start switch on once again. The screen following the measurement of both eyes disappears and the instrument returns to the measurement state.
- The newest measured values can be stored in memory for a maximum of 8 cycles each for right and left.

When data for the ninth or subsequent cycles is measured, data for the oldest cycle are deleted.

- The figures below show measurement screens for R (refractive mode) and K (keratometric mode):

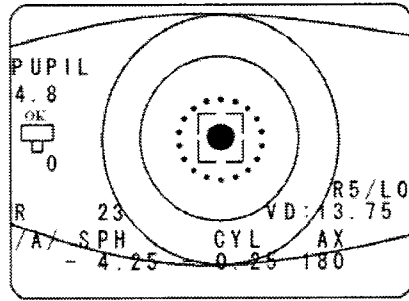

Ref measurement screen

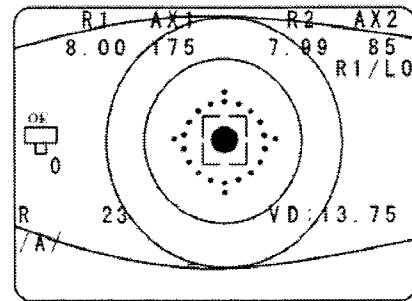

Kerato measurement screen

- A black shadow develops if the pupil has a something that obstructs light during measurement (such as opacity in the crystal lens due to a cataract, scars in the eye, etc.).

If a black shadow is seen, we recommend performing the observation following “5-6 Retroillumination Mode” (p.60) followed by other ophthalmic examination such as using a slit lamp.

4-5 Continuous Measurement Mode

Under this mode, the examiner ends the measurement.

1. On the "7-2 SETUP-MENU Screen" (p. 69), set "READING" to "CONT". (/C/ is displayed on the screen.)
2. Press  key and select the R-K mode.
3. Take a measurement using the same procedure as in the "4-4 Automatic Measurement Mode" (p. 30).



- In this mode, measurement does not end automatically.
- We recommend that the measurement be performed at least five times for each eye.

Increase the number of measurement cycles further if the eye moves frequently or measurement values vary. For refractive or keratometric measurement, results on the most recent eight measurement cycles for each eye can be stored.

4. To end the measurement, press the start switch. (This pauses the measurement.) Or, switch over to the other eye halfway during the measurement.
5. Switch over to the other eye and measure it in the same manner.
6. To print out the measurement result, press  key (p. 61).

4-6 Quick Measurement Mode

The “Quick Measurement Mode” allows a shortening of the time from the start of measurement to display.

- This mode is useful in cases where measurement is difficult, because of rapid eye movements due to nystagmus or if the patient is a child, or other reason.



- In the quick measurement mode, refractive measurement takes about half the ordinary time, but measurement values tend to vary more widely.
- In the quick measurement mode, the time taken for keratometric measurement is not changed.
- When printing, a letter “Q” to indicate quick mode is printed on the print paper.

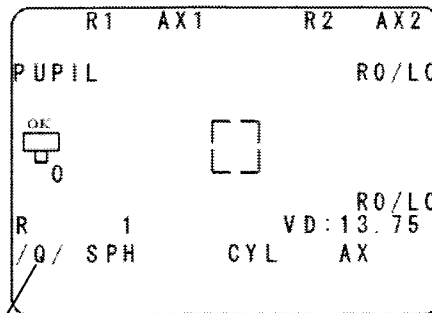

Quick measurement mode indicator

1. Press  key to select quick measurement mode.
(/Q/ appears on the screen.)
2. Take measurement using the same procedure as in the “4-4 Automatic Measurement Mode” (p. 30).



- In this mode, measurement does not end automatically, but runs continuously.
- We recommend that the quick measurement be performed at least five cycles for each eye.
Increase the number of measurement cycles further if the eye moves frequently or if refractive measurement values vary. For refractive and keratometric measurement, results on the most recent eight measurement cycles for each eye can be stored.

3. To end the measurement, press the start switch. (This pauses the measurement.) Or, switch over to the other eye halfway during the measurement.
4. Measure the other eye in the same manner.
5. To print out the measurement result, press  key (p. 61).

Examples of print-outs

```

- 5.75 - 1.25  7  Q
- 5.75 - 1.25  5  Q
- 5.75 - 1.25  7  Q
- 5.75 - 1.25  5  Q
    
```

Indicates the measurement was done in the quick mode.

The following shows the operations using the "Quick Mode."

R-K mode	R-K mode	R mode
<p>Quick mode</p> <p>With this mode, the refractive measurement takes about half the ordinary time.</p> <p>Time for keratometric measurement is unchanged.</p>	<p>Auto start</p> <p>↓</p> <p>A set of the following measurements is taken in the continuous mode</p> <div data-bbox="711 926 1024 1297" style="border: 1px solid black; padding: 5px;"> <p>Ref/Kerato measurement (set of 1 measurement cycle each)</p> <p>+</p> <p>When using the pupil diameter measurement function, the pupil diameter measurement is taken after the refractive measurement.</p> </div>	<p>Auto start</p> <p>↓</p> <p>A set of the following measurements is taken in the continuous mode</p> <div data-bbox="1062 926 1382 1297" style="border: 1px solid black; padding: 5px;"> <p>Ref measurement</p> <p>+</p> <p>When using the pupil diameter measurement function, the pupil diameter measurement is taken after the refractive measurement</p> </div>

4-7 Keratometric Peripheral (PERI) Measurement

1. Press  key. The main unit enters the keratometric peripheral measurement mode and changes the screen.

2. Adjust the mire ring and alignment mark into rough alignment, and then press the start switch. (This is the same procedure as used for normal keratometry.)

Light spots flash and the measurement repeats. Measurement alternates horizontally between the center and periphery.

3. After the measurement is repeated several times, press the start switch. The measurement ends and the cursor moves to the next row. If the vertical peripheral measurement is not needed after horizontal peripheral

measurement, press  key to print out the data.

If you want to proceed with vertical

measurement, do not press  key, but go to the next steps.

4. For vertical measurement rotate the main unit 90°. Specifically, being sure that the cursor is at the position shown on the right figure, make the “up” direction mark appear at the top.

5. Start the measurement. Do the same as you did in the horizontal measurement

After performing the measurement several times,

press  key.

6. If you print after performing refractive measurement, keratometric measurement, and keratometric peripheral measurement, the values for all three measurements will be printed out. If you only measure the keratometric peripheral measurement, only the keratometric peripheral value will be printed out.

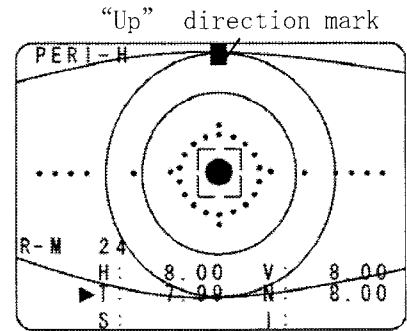
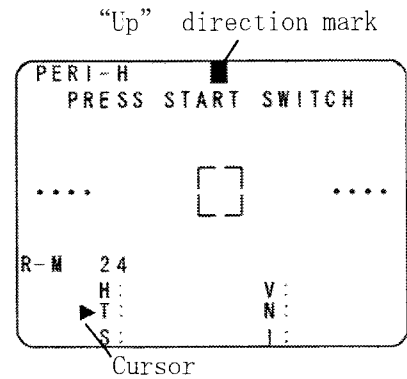

“Up” direction mark

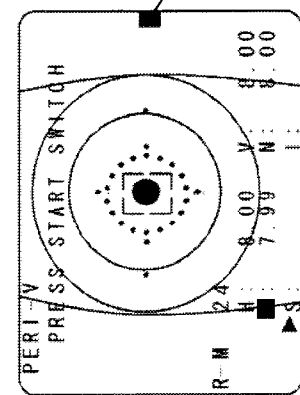

PERI horizontal measurement screen



- In peripheral measurement, R/L identification is a manual operation.
- Do not use the forehead rest during vertical measurement. There is a danger that it will hit the opposite eye of the patient.
- Vertical measurement may not be possible as the measuring beam is obstructed by eyelashes or upper eyelid. Ask the patient to open the eye wider before starting the measurement.

4-8 Helpful Hints for Successful Measurement

▼ If the right/left eyes are not properly identified

- To ensure proper operation of the automatic right/left eye identification, note the following:

- When extending your hands between the patient's face and the main unit to stabilize the main unit, do not touch the right/left eye sensors. (p15)
- Take measurement squarely in front of the patient's face as shown below. Identification may fail if measurement is taken at an angle upward or sideways.

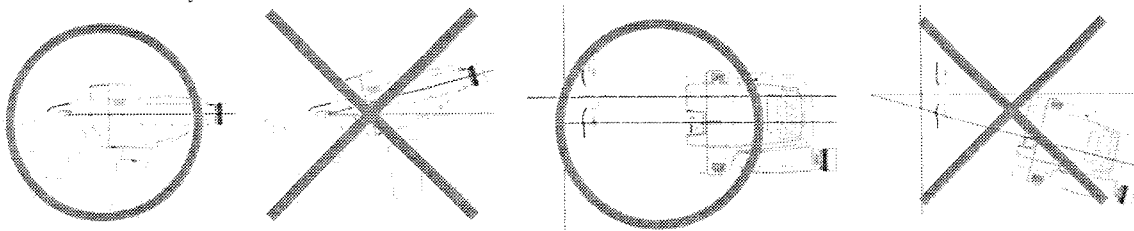

- If you follow the above main unit but the right/left eye identification still does not work properly (for example, the measuring window is brought near the left eye, but the right/left eye indicator remains "R"), switch to the manual right/left eye identification.

The right/left eye identification can fail if:

- The patient is wearing a mask.
- A female patient has a great deal of hair on either cheek.
- The face is small, in the case of a child or baby.





Switching to manual eye identification is also required when taking measurement from above the head or at an angle sideways or upward.

- Switching from automatic right/left eye identification mode to manual mode

Press  key on the switch panel of the main unit.

- Right eye measurement is selected, with the R/L "AUTO" lamp turned off and the "R" (right eye) lamp turned on.
- Press  key once again. Now, left eye measurement is selected, with the "L" (left eye) lamp turned on.

Pushing  again toggles between right and left.

If you want to restore the automatic right/left eye identification, press  key.

[This does not apply if "RL SENSE" is set to "MANUAL" on the "7-3 HOLD MODE Screen" (p. 70).]



Once  key is pressed, the data is cleared when you take a new measurement.

If you press  key (which triggers a printout of any set data) and then want to change the right/left eye identification from manual to automatic mode, press

 key once again.

▼ **Measurement from 45°, 90°, or 135° rotated position**

If you need to perform measurement from a 45°, 90°, or 135° rotated position, as for bedside measurement, Ax must be set appropriately.

Set the automatic correction angle to suit the measuring position as illustrated on the right.

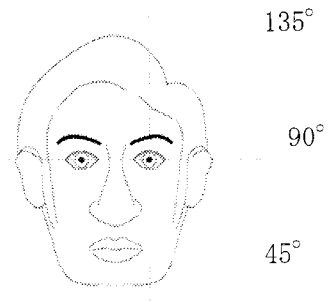

Each press of  key on the switch panel of the main unit applies a cylinder axis angle correction in order of 45° → 90° → 135°. Pressing the key after a 135° correction clears the correction function. The Ax change indicator lamp is lit while the cylinder axis angle Ax is corrected for 45°, 90°, or 135°. The right/left eye identification automatically changes from automatic mode to manual mode.

Pressing  key prints the data and clears the correction. [This does not apply if “AX ROTATION” is set to “HOLD” on the “7-3 HOLD MODE Screen” (p. 70)] When printed, the Ax correction mark (p. 63) appears also on the print paper.



While the cylinder axis angle is being corrected, the Horizontal Indication Function switches off.

▼ **Using the forehead rest**

The forehead rest facilitates measurement if the patient’s eye tends to move or you cannot hold the main unit



CAUTION

Do not use the forehead rest for a patient (such as a small child) who moves the face restlessly, as this can lead to injury of the face.

1. Apply your finger to the middle of the forehead rest of the main unit and push it in the arrow (△) direction. The entire forehead rest comes out.
2. Bring the forehead rest into light contact with the patient’s forehead and adjust to the measurement distance by looking into the viewfinder.
3. To put the forehead rest out of use, retract it by pushing it again in the arrow direction.
4. When placing the main unit onto the station, be sure to retract the forehead rest.
5. When performing a measurement without the forehead rest, it is easier to conduct the measurement if you put your idle hand between the patient and the instrument.

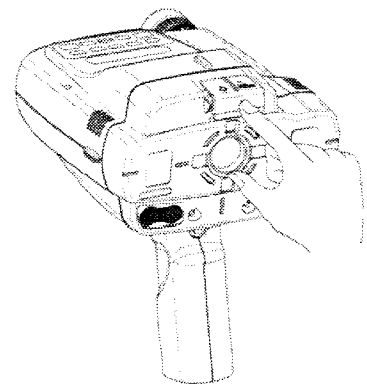

▼ If measurement is unstable (during refractive/kerato metric)

- If eyelashes conceal the patient's eye, ask the patient to open the eye wider. If eyelashes are still hanging over, you may ask an assistant or the patient to lift the upper eyelid lightly with a finger.
- Blinking during measurement may hinder the measurement.
- Measurement may fail or may not produce reliable values if the patient has an eye disease such as cataract; opacity in the cornea, crystal lens, vitreous body; or retinal detachment.
- Measurement may fail or may not produce reliable values, if the pupil diameter is smaller than $\phi 2.3$ mm.
- Measurement fails if <S+C> is out of the measurement range of -18D to +23D, or if <C> is out of the measurement range of OD \sim -12D to OD \sim +12D.
- When using the "Auto Quick Function" (p.50), the likelihood of obtaining data out of the measurement range is quite high.

● Measuring an eye with a contact lens

Usually, measured values can be obtained. However, if the contact lens is not properly fitted, correct values may not be obtained. Dirt or scratch on the contact lens may hinder measurement.

● Measuring an eye with an eyeglass

Measurement is possible if the lens is at a slight incline. If the lens is at a larger incline, correct values will not be obtained. If light is reflected from the lens surface into the measuring window, or if the glasses have a colored lens with a low light transmission, the measurement may fail.

▼ Precautions

 Eyelashes concealing the eye can contribute to improper measurement. Note the following:

- Support the main unit in a horizontal position at the elevation of the patient's eye.
(The eye tends more to be concealed by eyelashes when measured at an angle from above.)

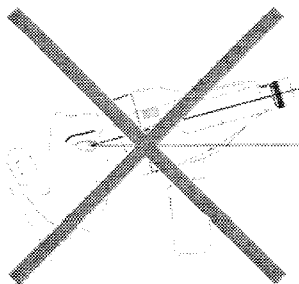
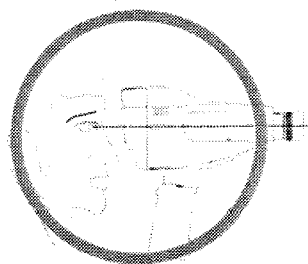

- Once the eye is focused, eyelashes may not be clearly visible through the viewfinder. When adjusting the focus, move closer to the patient and look for eyelashes. If eyelashes are interfering, instruct the patient to open the eye wider.



Cylinder axis deviation may occur if the main unit is not horizontally aligned with the eyes. Take care before looking into the viewfinder.

Using the horizontal indication function makes it easier to align the main unit with the eyes even while looking into the viewfinder. [See “5-3 Horizontal Indication Function” (p.49).]

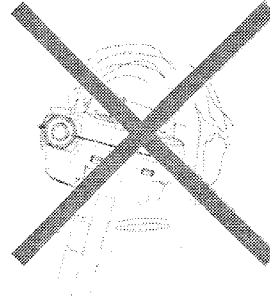
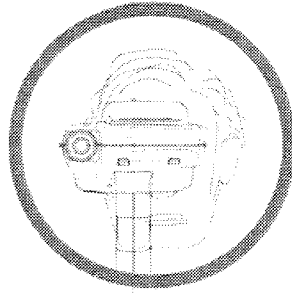

When holding the main unit, keep your elbows close to your body and grasp the grip firmly to avoid hand jiggling.

Hand jiggling tends to occur more if your elbows are far away from your body.

▼ How to use the melody

Hold down  key for more than 1 second, and a melody is played from the instrument.

To stop the melody, press the start switch, or press  key once again. It is sometimes difficult to measure children as they try to push the main unit away.

The melody can be used for such patients to create interest in the main unit or to remove fear associated with the measurement.

The melody cannot be played while conducting a measurement.

4-8-10 Others: Considerations for Measurement

▼ Automatic fogging

The automatic fogging system minimizes the patient's eye accommodation. The instrument automatically enters the fogging state when alignment is achieved between the patient's eye and the main unit.

Be sure to tell the patient to look at the fixation target.

(1) When the alignment for measurement is complete, the target appears blurred (the fogging state is entered).

↓

(2) The instrument performs automatic measurement.

(3) A short beep sounds with a measurement run.

↓

(4) For the patient, the target remains fogged.

↓

(5) The next measurement starts.

▼ If keratometric measurement is not possible

If keratometric measurement cannot be performed, check for obstructions of the measuring beam by eyelashes or the upper eyelid.

Lift the upper eyelid, or otherwise correct the cause so that the measuring beam is not obstructed.

During refractive/keratometric measurement or keratometric measurement, bright spots for keratometric measurement are reflected on the patient's cornea and can be seen on the screen through viewfinder. If any of these spots cannot be seen, or looks chipped or blurred, the measuring beam is blocked. Causes include interference by eyelashes or the upper eyelid, blinking, and corneal lesion.

If keratometric peripheral measurement fails on the nose side (N), it is possible that the patient's face is not directed squarely to the front and the nose is obstructing the measuring beam. Check for this.

▼ Measurement of IOL eyes

- This instrument can measure an IOL (intraocular lens) implanted eye in the same process as the normal eye without any special switch setting. Depending on the type of IOL or the condition of the IOL eye, the reflecting light from the IOL may disable the measurement, lead to a degradation of the confidence level of measured values, or result in larger measurement errors.
- If it is difficult to obtain measurements, using the Quick Mode may make the measurement easier.
- If the auto quick function is set beforehand, it automatically changes to "Quick Mode" [See "5-4 Auto Quick Function" (p.50)] only when the measurement is difficult to perform, thus allowing you to perform measurement.

▼ If measured values are not obtained

Normally, measured values should be displayed when they are obtained. If they are not obtained even when the instrument is aligned, there may be an unusual condition. Here are some workarounds.

- For a patient with drooping eyelashes, the eyelashes must not be within the outer contours of the alignment mark on the screen in the viewfinder. Ask the patient to open the eye wider, and if eyelashes are still drooping, you may have an assistant or the patient lift the upper eyelid lightly with a fingertip.
- If the eye blinks during measurement, the measurement is automatically redone.
- Measurement may be impossible if the patient has an eye disease such as cataract; opacity in the cornea, crystal lens, or vitreous body; or retinal detachment.
- Measurement cannot be made if <S+C> is out of the measurement range of -18D to +23D, or if <C> is out of the measurement range of 0D ~ -12D to 0D ~ +12D.
- Measuring an eye with a contact lens
Measurements can usually be obtained. However, if the contact lens is not properly fitted, correct values may not be obtained. Dirt or scratch on the contact lens may hinder measurement.
- Measuring an eye with an eyeglass
Measurement is possible if the lens is at a slight incline. If the lens is at a large incline, the correct values will not be obtained. If light is reflected from the lens surface into the measuring window, or if the glasses have a colored lens with a low light transmission, the measurement may fail.

▼ Representative values

Representative values are median values of the measurement.

On the printout of measurement results, representative values are marked with an asterisk “ * ”. See the “6-3 Samples Printouts” (p.63).

The confidence level is shown for representative values. The smaller the variation between measured values, the closer the confidence level is to 10.

If measured values vary widely, such as in refractive measurement, and you want to select one from among them, note the following tips:

- If only the SPH values vary widely:
The patient's eye may be accommodating. Measure the same eye once again.
- If the CYL and AX values vary widely:
When CYL indicates weak astigmatism (below 0.5D), AX tends to be somewhat unstable.
Other possible causes include:
 - Eyelashes are hanging over the pupil.
 - The main unit was tilted while the measurement was performed.
 - The pupil diameter is smaller than 2.3 mm, which is the minimum measurable pupil diameter.
 - The eye is partially opaque, or is irregularly astigmatic.

In the above cases, the confidence level is typically low.

If eyelashes or pupil size are the cause, correct the problem and retry the measurement.

▼ Refractive confidence level

The refractive confidence level indicates the degree of variation between measurement results. It is given only after a measurement is run three or more times; it appears at the right end of measurement results on printout. See the “6-3 Samples Printouts” (p.63).

- 8 or higher: Low variation.
- 7 or lower: High variation. Care is needed in interpreting the measurement results.

▼ Auto power off

When no key is pressed for three minutes or more while no measurement is being performed, the main unit automatically switches off.

To resume measurement, turn the power back on by pressing  key.

▼ Measurement of hard contact lens base curve

(Soft contact lenses cannot be measured.)

1. Drip water onto the hard contact lens holder shipped with the instrument.
2. Place the lens on the hard contact lens holder. (Direct the front or rear side of the lens -- whichever to be measured -- toward the measuring window of the main unit.)
3. Perform the measurement using the usual keratometric measurement method.

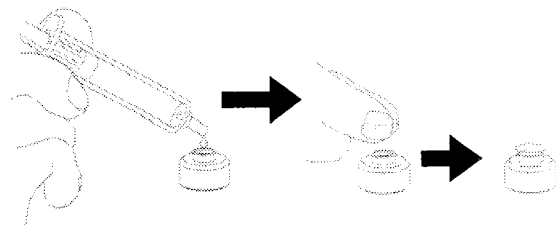

Hard contact lens holder



4-8-2 Battery Low Indication

When the remaining battery level falls below half, a battery low sign appears.

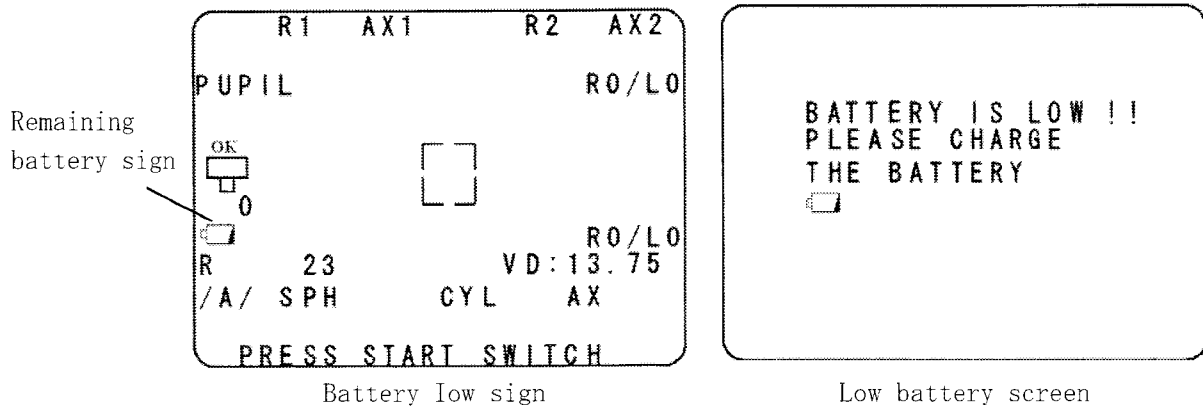
When the remaining battery charge decreases below the operable voltage level, the battery low screen appears. Power will go off after 10 seconds.



Remaining battery charge mark

State of remaining battery charge	Mark, sign
Sufficient charge	No sign
Half	 mark appears
Very low Battery needs to be recharged	 mark appears
Battery charge is too low for operation Battery needs to be recharged	The low battery screen appears, and power switches off automatically after 10 seconds

If the low battery screen appears, recharge the battery [see “3-4 Charging the Battery Pack” (p.22)], or switch over to the power supply from the station [see “3-5 Power Supply from the Station” (p.24)], and then restart the measurement.

5. Various Functions

5-1 Pupil Diameter Measurement Function

- This instrument is equipped with a pupil diameter measurement function that interlocks with the refractive measurement.
- The pupil diameter measurement can be performed when “R/K: Ref/Kerato mode” (p.29) is on.

1. Press  key several times until the “PUPIL” LED lights. When the LED is lit, the instrument enters the pupil diameter measurement mode and “PUPIL” appears on the measurement screen.

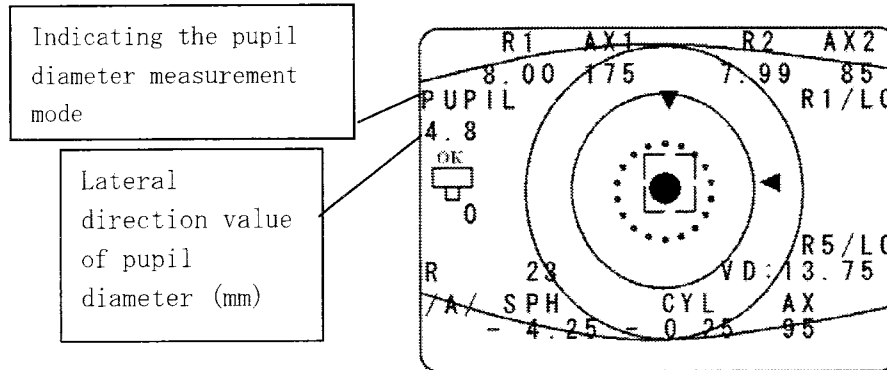

- The pupil diameter measurement automatically follows refractive measurement.
- The maximum values of pupil diameter both in lateral and vertical direction are measured.

Range of measurement: 2.0 mm - 10.0 mm
Measurement step: 0.1 mm



- Pupil diameter cannot be measured when the instrument is in “Keratometric mode.”
- If the light is blocked by eyelashes or an eyelid, the measurement, in particular in the vertical direction, may not be done.

2. Press  key several times to disable the pupil diameter measurement function.
3. When the “PUPIL” on the “7-2 SET-MENU Screen” (p.69) is set to “ONE,” pupil diameter is measured only once for each eye.
4. When the “PUPIL” on the “7-2 SET-MENU Screen” (p.69) is set to “ALL,” the pupil diameter measurement is always performed after the refractive measurement.
5. When the values of both lateral and vertical values of pupil diameters are measured at less than 3.0 mm, the eyes may be miotic, and therefore the brightness of the fixation target is automatically reduced.

5-2 Alignment Direction Indication Function

- The alignment direction indication function is used to indicate the direction for placing the bright spot within the standard mark during the measurement. Move the main unit in the indicated directions, and measurements will be obtained more easily.
- On the "7-2 SET-MENU Screen" (p.69), set INDICATOR to ON. When it is set to OFF, the direction indication marks are not displayed.
 - Start the measurement.
 - When the LED for measurement is exposed to the eye, the alignment direction indication keys are displayed.

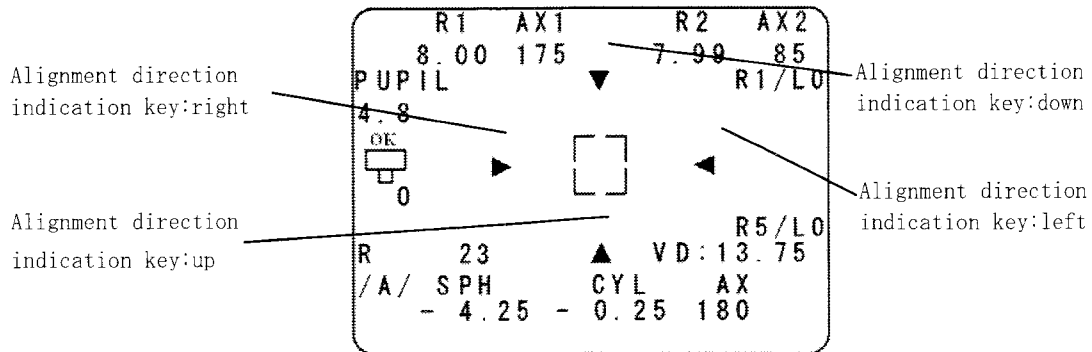

- Moving the main unit in the indicated directions establishes proper alignment. When the alignment direction indication keys are shown as seen in the figure below, proper alignment can be established by moving the main unit toward the lower left.

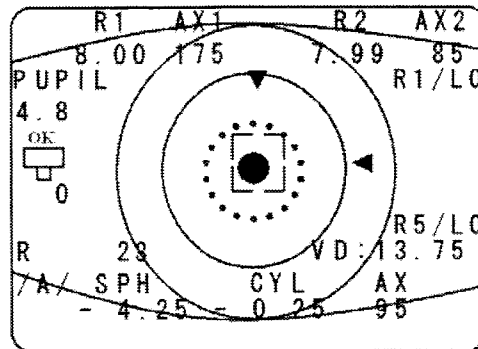

When the instrument is in keratometric peripheral (PERI) measurement mode (p.38), the alignment direction indication key does not appear.

5-3 Horizontal Indication Function

The horizontal indication function indicates the tilt direction of the main unit during measurement so that the main unit can be held in the horizontal position. It indicates the degree of the main unit's tilt to the right side and left side. This function helps to make measurement of the cylinder axis more accurate.

1. On the "7-2 SET-MENU Screen" (p.69), set "PARALLEL" to ON.
A horizontal indicator appears on the measurement screen.
The horizontal indicator does not appear when it is set to OFF.

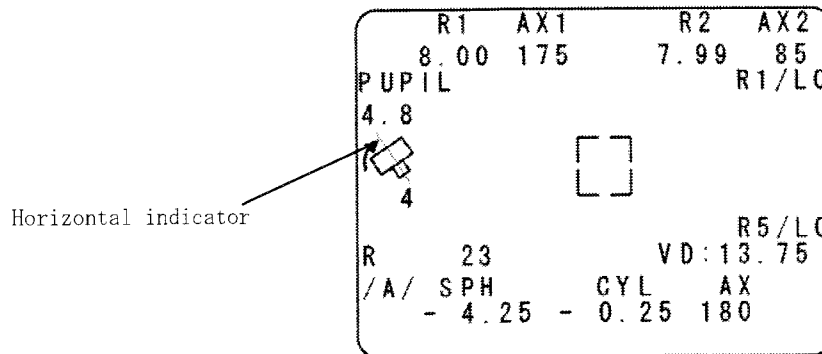

2. The horizontal indicator displays tilt angles up to 12° each to the right and left, in increments of 2°; it displays tilt angles over 12° and up to 45° each on the right and left, in increments of 3°.
3. Perform the measurement after correcting the tilt angles of the main unit to the directions where the horizontal mark is displayed (see the figure below).

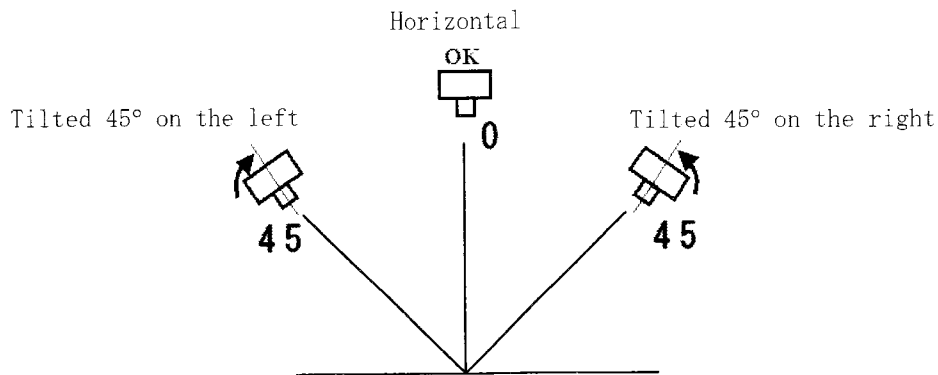

- The horizontal indicator does not appear when  key on the main unit switch panel is used to correct the cylinder axis angle AX.
- When the instrument is in "keratometric peripheral (PERI) measurement mode" (p.38), the horizontal indicator does not appear.
- This function is used to indicate the tilt of the main unit and not to correct the data.

5-4 Auto Quick Function

Refractive measurements may be difficult to obtain due to rapid eye movements in patients with nystagmus or children, or for other reasons. In such a situation, the auto quick function automatically activates the quick measurement mode which requires less time for measurement.

Under the auto quick function, the quick measurement mode is automatically activated when refractive measurement cannot be executed normally for a certain time (6 seconds) after start of measurement.

1. On the "7-2 SET-MENU Screen" (p.69), set "AUTO QUICK" to ON.
2. When the measurement cannot be executed after 6 seconds, the Auto quick measurement mode is set.

Under the following conditions, the Auto quick measurement mode is set.

Conditions	
1	A refractive measurement cannot be executed for 6 seconds after the start of measurement
2	A refractive measurement was successfully executed, but the next measurement cannot be performed for 6 seconds
3	Some key operation is done during the measurement, but the next refractive measurement cannot be done for 6 seconds
4	The right/left eye identification mode is set but the next refractive measurement cannot be executed for 6 seconds

3. After the main unit switches to auto quick mode, the measurement screen indicates it as "A-Q."

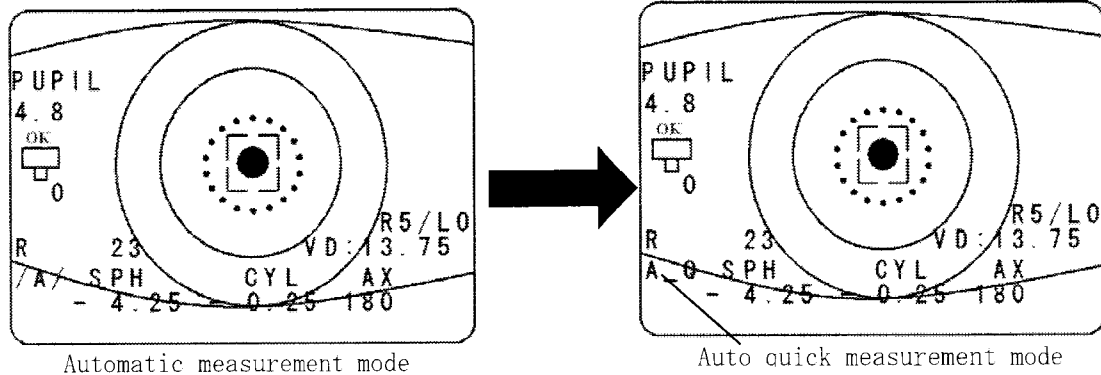

4. The Auto Quick Function only changes if the machine is in "Automatic Measurement Mode (AUTO)" (p.30). It will not change if the instrument is in "Continuous Measurement Mode (CONT)" (p.35).

The following is the conditions for the completion when there is switch to Auto quick measurement mode.

Measurement mode	Completion condition
Auto quick measurement mode	The instrument automatically determines the completion of the measurement The measurement completion condition is the same as for the usual automatic measurement mode

5. When the measurement of one eye ends, the Auto quick measurement mode is disabled.

The following are the conditions for the disabling of the measurement with the auto quick function.

Conditions	
1	Measurement of one eye with the automatic measurement mode ends
2	Measurement is suspended by pressing the start switch
3	The right/left eye identification is switched
4	A key operation is done during measurement
5	The measurement is completed

6. When the auto quick function being activated, "AQ" is printed on the measured data.

```
- 5.75 - 1.25  5  AQ
- 5.75 - 1.25  5  AQ
- 5.75 - 1.25  7  AQ
- 5.75 - 1.25  5  AQ
```

This indicates that the measurement was performed with the auto quick function

Sample printout



- In the Auto quick measurement mode, refractive measurement takes about half the ordinary time, but measurement values tend to vary more widely.
- The quick measurement mode does not affect the length of keratometric measurement.

5-5 Memory Function

This instrument has two memory functions: one is a memory function that stores data for 50 persons (100 eyes) and the other is the last data memory function. The following is a brief description of these functions.

	Memory name	Functions
1	Memory function for 50 persons (100 eyes)	This function allows storage of data for 50 people (100 eyes) into memory. When the memory function is set to "ON", if you press the  key after measurement, the measured data can be printed, delivered externally and at the same time stored into memory.
2	Last data memory function	With this function enabled, the data will always be saved into memory before the power shutdown.

- Memory function for 50 persons (100 eyes)
The following explains how to store data into memory and how to print out saved data using this function.

● Explanation of MEMORY-MENU screen

Press  key for more than 1 second.

The measured values (for up to 50 persons) stored in the instrument can be printed out, delivered externally or deleted.

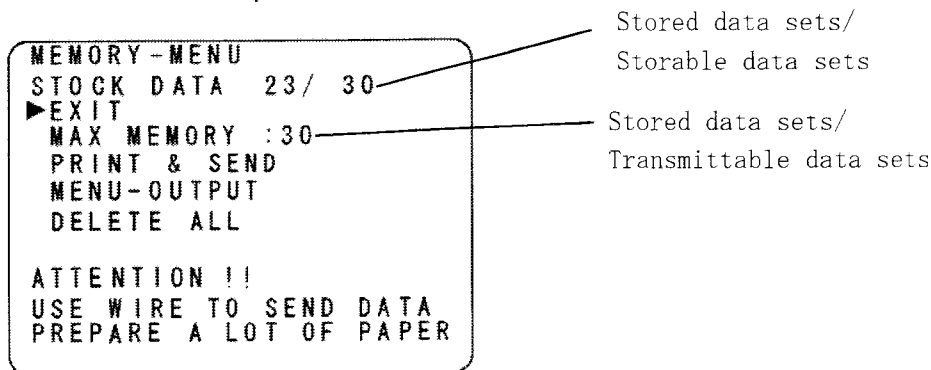

MEMORY-MENU screen

Item	Description
EXIT	Move to the measurement standby screen
MAX MEMORY	Storable data sets Changeable from 10 to 20 to 30 to 40 to 50 (default setting 10)
PRINT & SEND	Print or externally deliver stored data
MENU-OUTPUT	Display "7-4 OUTPUT Screen" (p. 71)
DELETE ALL	Delete all stored data

■ **Selecting an item**

A menu item is selected when the cursor (▷) is located to its left.



To move the cursor, use one of these keys:

 key: Moves the cursor (▷) down.

 key: Moves the cursor (▷) up.

To set an item press  where the cursor (▷) of the selected item lies.

● **Storing data of measured values into memory**

1. Press  key while waiting for the measurement.
2. The LED lights for  key appear on the switch panel, and the number of current data sets stored is displayed on the measurement screen.

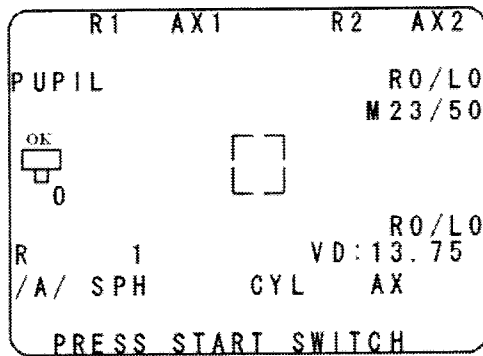

Stored data sets/Storable data sets
(in this case the stored data is for the 23rd person)

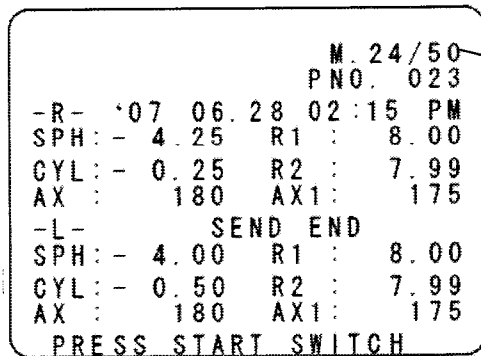

Measurement screen at the time of setting the measurement values to be stored

3. Perform measurement.
4. Press  when the measured values are determined.
5. The measured values can be printed out or externally delivered, and the data are stored into memory.



Number of stored data sets/
Storable data sets

Printing completion screen

 Once the  key is pressed and measurement results are stored, any further press of the  key will not activate the storing function until the next measurement is complete.
 (This is to prevent duplicate storing of identical values.)

● When the memory becomes full

When the data stored into memory reaches the maximum storable level, no more data can be stored.

The MEMORY-MENU screen and the Measurement screen indicate “FULL.”

```

MEMORY-MENU
STOCK DATA 50/ 50 FULL
▶EXIT
MAX MEMORY :50
PRINT & SEND
MENU-OUTPUT
DELETE ALL

ATTENTION !!
USE WIRE TO SEND DATA
PREPARE A LOT OF PAPER
  
```

MEMORY-MENU screen
 (When the stored data reaches the maximum storable level)

Indicates that the stored data into memory has reached the maximum level

```

R1 AX1 R2 AX2
PUPIL
R0/L0
M50/50
FULL

OK
0
R 1 VD:13.75
/A/ SPH CYL AX
PRESS START SWITCH
  
```

MEASUREMENT screen
 (When the stored data reaches the maximum storable level)

■ When you want to start storing new data

● Clear all data

1. Press  key for more than 1 second.
2. Confirm that the “MEMORY MENU” appears.
3. Select “DELETE ALL”
4. Confirm that the “MEMORY ALL DELETE” screen appears.
 - When “DELETE” is selected, a melody plays, the delete confirmation screen appears, and all stored data are deleted and the number of data to be stored is reset.
 - When “NOT DELETE” is selected, the data deletion stops.

```

MEMORY ALL DELETE
STOCK MEMORY COUNT 50/50
DELETE ALL DATA
REALLY?

▶NOT DELETE
DELETE
  
```

MEMORY ALL DELETE screen



5. When "DELETE" is selected, the Delete confirmation screen appears.

```
MEMORY DATA CLEARED
STOCK MEMORY COUNT 0/50
▶EXIT
```

DELETE CONFIRMATION screen

6. Press  key and return to "MEMORY" screen.

● Changing the storable data sets

1. Press  key for more than 1 second.
2. Confirm that the "MEMORY MENU" appears.
3. Move the cursor to "MAX MEMORY" and press  key, and the number of storable data sets can be changed.

```
MEMORY-MENU
STOCK DATA 30/ 30 FULL
▶EXIT
MAX MEMORY :30
PRINT & SEND
MENU-OUTPUT
DELETE ALL

ATTENTION !!
USE WIRE TO SEND DATA
PREPARE A LOT OF PAPER
```

MEMORY-MENU screen

(When the stored data reaches the maximum storable level)

More data can be stored by changing the figure of "MAX MEMORY" to more than the current setting.



```
MEMORY-MENU
STOCK DATA 30/ 40
▶EXIT
MAX MEMORY :40
PRINT & SEND
MENU-OUTPUT
DELETE ALL

ATTENTION !!
USE WIRE TO SEND DATA
PREPARE A LOT OF PAPER
```

● Handling the case where new measured values are obtained when the stored data reaches the maximum level

- (1) "MEMORY" is effective
- (2) If the measurement is newly performed when the stored data reaches the storable level

1. The measurement will be newly performed under the situation mentioned above in (1) and (2).

2. Press  key.

3. Since the memory is full, the buzzer beeps three times and the "MEMORY FULL" screen appears.

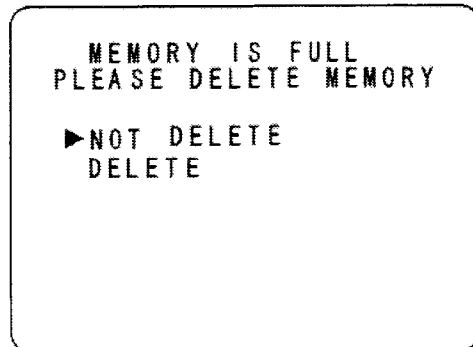

MEMORY FULL screen

4. Select "DELETE" on the "MEMORY FULL" screen, and the "MEMORY ALL DELETE" screen appears.

Also on the Memory All Delete screen, when "DELETE" is selected, a melody is played, the Data Delete Confirmation screen appears, and all stored data are deleted and the data number to be stored is reset.

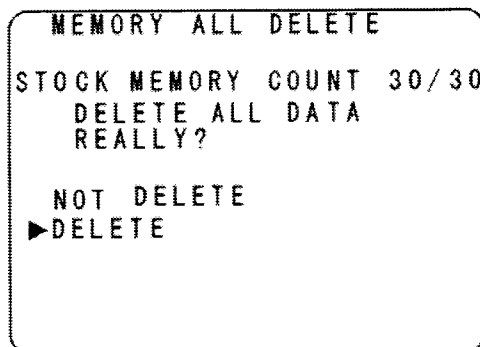

MEMORY ALL DELETE screen

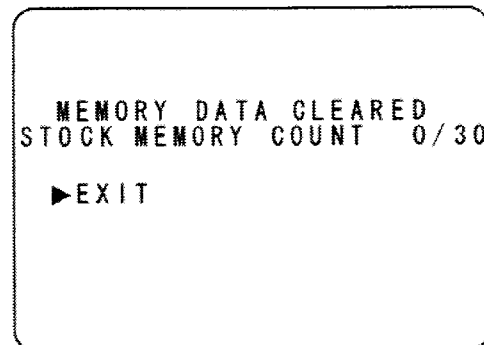

DATA DELETE CONFIRMATION screen

5. When selecting "EXIT" on the Data Delete Confirmation screen, the data is printed out and externally delivered, with the new data stored as the first data.

6. When "NOT DELETE" is selected on either the "MEMORY FULL" screen or "MEMORY ALL DELETE" screen, the new data are not stored, but are only printed out or externally delivered.

● Printing out stored data

The following is an explanation of how to print out stored data.

- Stored data are printed out in the order of oldest to newest.
- If a large volume of stored data is to be printed out via wireless communication, it is necessary to continue to aim the main unit toward the light receiving window of the printer. Otherwise, data may not be transmitted.

Therefore, use of a direct communication cable is recommended for printing.

1. Continue pressing  key in the standby state to call forth the “MEMORY -MENU” screen.

```
MEMORY-MENU
STOCK DATA 30/ 40
▶EXIT
MAX MEMORY :40
PRINT & SEND
MENU-OUTPUT
DELETE ALL

ATTENTION !!
USE WIRE TO SEND DATA
PREPARE A LOT OF PAPER
```

MEMORY-MENU screen

2.

- Confirm that the “PRT UNIT NO” matches the printer. Do not select “SELECT”
- Printout is done according to the data transmission format and external delivery format set in the “7-4 OUTPUT Screen” (p.71).
- Be sure to select “OFF” for setting “RV OUT” If it is “ON” the pupil diameter data are omitted. “Remote Vision” can be set only for the data of the first person.

To change the setup, move the cursor to “MENU-OUTPUT” and press  key, to display “7-4 OUTPUT Screen” (p.71).



- For printing out stored data, using a direct communication cable is recommended (p.62).
- Printing out a large amount of data requires many sheets of paper. Confirm that there is sufficient paper beforehand.
- When the paper runs out, do not turn off the power but feed new paper.

3. When you move the cursor to "PRINT & SEND" and press  key, all the stored data are sent.
4. Data transmission is done first to the printer and then to the external equipment.
5. If you want to stop the transmission, hold the start switch down for about 1 second.

```

MEMORY-MENU
STOCK DATA 30/ 40
EXIT PRINT & SEND
MAX MEMORY :40
▶PRINT & SEND
MENU-OUTPUT
DELETE ALL

ATTENTION !!
USE WIRE TO SEND DATA
PREPARE A LOT OF PAPER
CANCEL → PUSH START SW

```

MEMORY-MENU screen (printing)

Sending the maximum number of stored data as allowed by the storable data set setting

Blinks while data are transmitted

Indicates that transmission has been suspended by pressing the start switch for about one second

 Before printing, make sure that the printer battery is sufficiently charged. It is necessary to restart operation in the case when the power turns off during printing.

 • When printing out stored data, select a settable device number other than "SELECT" from among the "PRT UNIT NO." in the "7-4 OUTPUT Screen" (p.71). When it is set to "SELECT" data cannot be transmitted on the MEMORY-MENU screen.

If "PRT UNIT NO." is set to "SELECT", a caution will appear.

```

MEMORY-MENU
STOCK DATA 30/ 40
▶EXIT
MAX MEMORY :40
PRINT & SEND
MENU-OUTPUT
DELETE ALL

ATTENTION !!
USE WIRE TO SEND DATA
PREPARE A LOT OF PAPER
CHECK!! PRT UNIT NO

```

MEMORY-MENU screen

■ Automatic Data Backup Function

The automatic data backup function allows you to redisplay and print out the data obtained before the power shutdown in the following circumstances. By pressing  key after turning on the power.

- The power went off while carrying the main unit.
- The power was turned off by mistake.
- The power went off during data output such as printing or external delivery.

1. Turn on the power, and press . The “LAST DATA screen” appears, and the data effective immediately before the power shutdown is displayed, printed out or externally delivered.

```
LAST DATA
                PNO. 023
-R- '07 06.28 02:15 PM
SPH: - 4.25 R1 : 8.00
CYL: - 0.25 R2 : 7.99
AX :   180 AX1: 175
-L- PRINT & SEND
SPH: - 4.00 R1 : 8.00
CYL: - 0.50 R2 : 7.99
AX :   180 AX1: 175
```

LAST DATA screen

Time when  key is pressed after the power goes off



- If you access the menu screen, the data effective immediately before the power shutdown will be deleted.
- The automatic data backup function does not work if the retroillumination mode (p.60) was used immediately before the power shutdown.
- If power goes down during measurement, the data effective immediately before the power shutdown is not outputted if the measured values have not been obtained.
- The output time indicates the time when the power was turned on. Note that it is not the time when power went off.
- If the battery pack runs down, the automatic data backup function does not work.

5-6 Retroillumination Mode

The retroillumination mode is available in cases such as where measured values vary or the confidence level is low. This mode facilitates observation in the optic media.

1. Press  key several times until the "PUPIL" LED goes on. The retroillumination mode is selected and the screen changes accordingly. Once in the retroillumination mode, the fixation target illumination automatically changes to "Low."

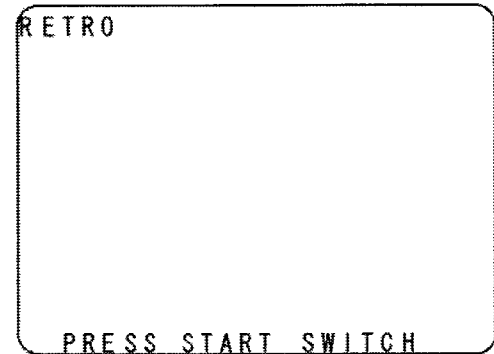

2. Press the start switch. The center bright spot becomes lit. Since the extraocular illumination (the light illuminating the iris and other extraocular area) goes out, you must set the instrument in the position beforehand from where the inside of the pupil can be observed. Any foreign objects, such as opacity in the crystal lens, that obstruct the measuring beam, appear as black shades on the screen.

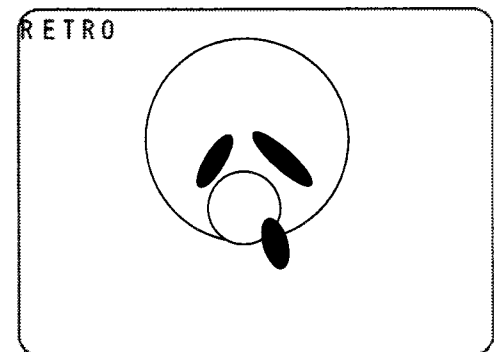

- A better view may result by shifting the image off center. In particular, an opacity existing in the center can only be seen by projecting light off the opacity.
 - Do not expose the patient's eye to external light (such as illumination from a fluorescent tube) as that may lead to a deterioration of visibility.
3. Press the start switch to restore the condition given in Step 1.
 4. Press  key to return to the original condition.



- The power automatically switches off after 3 minutes from starting observation with the Retroillumination Mode.
- When the Retroillumination Mode is used, the instrument does not make an R/L judgment.

6. Printing Out Stored Data

A printout can be made using either wireless or a cable connection. In either case, use the supplied printer.

6-1 For Wireless Communication

1. Set the print roll correctly. (p80)
2. After the end of the measurement, aim the front side (patient side) of the main unit toward the light receiving window of the printer, and press

the  key. The measured value will be sent to the printer wirelessly. You will hear a short beep, and the data reception lamp will light up.

Data are being transmitted as long as the noise continues from the main unit, so please do not remove the main unit from the printer's light receiving window during that time. When the sound ceases, the data transmission is completed.

- The functionality of printing is as set on:

- “7-5 PRINT Screen” (p.73) and
- “7-6 RS232C OUTPUT Screen” (p.74).

- To produce an eye print

- Move to the “7-5 PRINT Screen” (p.73) and set “Eye Print” to ON.
- If the EYE PRINT on the “7-5 PRINT Screen” (p.73) is set to “ON BY SW”, an eye print can be produced by pressing the  key for one second.

3. The printer discharges paper showing the measured values. Tear out the paper by pulling it toward you.

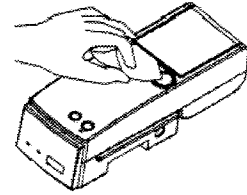
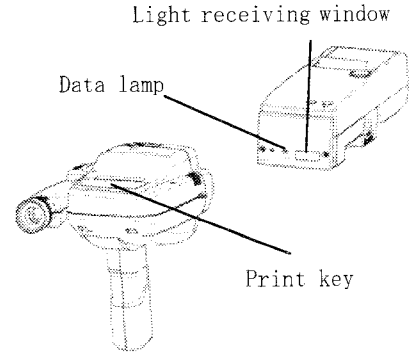

The printer may fail to operate in the following situations:

- The light from the main unit does not reach the printer when, for example, a person passes between the main unit and printer.
- The printer is used at a place more than 6 m away from the main unit.
- There is an angle of more than 45 degrees between the front side of the main unit and the light receiving window of the printer.

In such cases, move near the printer and press  once again to send data. Printout can be made as many times as necessary before the next measurement starts.

When measuring the next patient, be sure to make a printout before starting the measurement.



Retinomax 3 series cannot be used with a printer provided for use with Retinomax, Retinomax K-plus, Retinomax 2, or Retinomax K-plus2.

6-2 For Wired Connection

The following explains how to make a printout using a direct print cable.

1. Set the print roll correctly. (p80)
2. After the end of the measurement, connect the main unit and printer via the direct print cable, and then press  key.

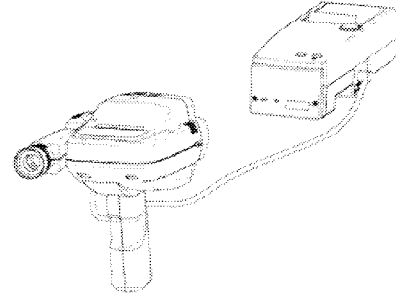

The measured data is transmitted through the direct cable to the printer and printed out there. When the printer receives data normally, it makes a short beep, and continues to receive the data. The data lamp will remain lit while the data are being received, so do not remove the cable from either the main unit or the printer at this time. When the sound stops, the data transmission is completed.

- The functionality of printing is as set on:

- “7-5 PRINT Screen” (p. 73) and
- “7-6 RS232C OUTPUT Screen” (p. 74).

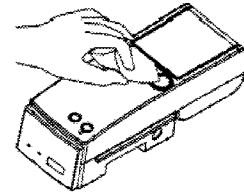

- To produce an eye print

- Move to the “7-5 PRINT Screen” (p. 73) and set “EYE PRINT” to ON.
- If the EYE PRINT on the “7-5 PRINT Screen” (p. 73) is set to “ON BY SW” , an eye print can be produced by pressing the  key for one second. after the regular printing is completed.

3. The printer discharges paper showing the measured values.
Tear out the paper by pulling it toward you.



- If the connector is not properly connected to the main unit or the printer, you may not be able to make a printout. Make the connection again and press  key once again to send data.
- When measuring the next patient, be sure to make a printout before starting the measurement.



Retinomax 3 series cannot be used with a printer provided for use with Retinomax, Retinomax K-plus, Retinomax 2, or Retinomax K-plus2.

6-3 Sample Printouts (When KER PRINT Is Set to ALL for Keratometric Measurement)

See Section 7, "Setting Up the Instrument" (p.67).

Sample printouts

Sample printout of ref values + pupil diameter values

Sample printout of keratometric measurement

Add names by hand writing as needed.

Measurement date/time: '07. 8.17 14:58

Patient number: Name: No. 003

Corneal vertex distance: VD: 13.75

-REF-

[R] Measured Ref values + pupil diameter values (right eye)

SPH	CYL	AX
+ 6.00	- 1.75	36
x 4.6	y 4.6	
+ 6.00	- 1.75	37
x 4.6	y 4.6	
+ 6.00	- 1.50	37
x 4.6	y 4.6	
+ 6.00	- 1.75	38
x 4.6	y 4.6	
+ 6.00	- 1.75	37
x 4.6	y 4.6	

Representative Ref values + pupil diameter values (right eye): * + 6.00 - 1.75 36 10
x 4.6 y 4.6

Right-eye confidence level (p.45)

AX correction mark
AX/ 45: 45° correction
AX/ 90: 90° correction
AX/135: 135° correction
AX: No correction

Quick mode mark

[L] Measured Ref values (left eye)

SPH	CYL	AX/90
+ 5.75	- 1.25	42 Q
+ 5.75	- 1.25	42 Q
+ 5.75	- 1.25	42 Q
+ 5.75	- 1.25	42 Q
+ 5.75	- 1.25	41 Q

Representative Ref values (left eye): * + 5.75 - 1.25 42 10

Left-eye confidence level (p.45)

-KER-

[R] Keratometric measurement values (right eye)

R1	R2	AX1	AX2
8.38	8.12	42	132
8.37	8.13	41	131
8.39	8.12	41	131

Representative keratometric measurement values (right eye): * 8.38 8.13 41 131
mm D deg

[L] Keratometric measurement values (left eye)

R1	R2	AX1	AX2
8.44	8.14	40	130
8.44	8.14	40	130
8.45	8.13	40	130

Representative keratometric measurement values (left eye): * 8.44 8.14 40 130
mm D deg

[L] Representative keratometric values (left eye)

R1	R2	AX1	AX2
8.44	8.14	40.00	40
8.14	41.50	130	
8.29	40.75		

Message: OFFICE NAME
Telephone number

Eye Print Printout

'07. 8.17 14:58
 Name:
 No. 003 VD: 13.75

[R] SPH CYL AX
 - 4.75 - 0.25 168

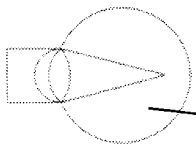

OFFICE NAME
 Telephone number

Right eye center
 fixed horizontal
 value

Right eye center
 fixed vertical
 value

Eye print

Message

Right-eye eccentricity
 Comparison between center
 curvature and peripheral
 curvature.
 This data means the following:

- Approx. 0.5 in standard condition.
- The closer to 0, the more spherical.
- The closer to 1, the greater the peripheral eccentricity.

Use this as reference values
 when selecting contact lenses.

Left eye eccentricity

Message

PERI Printout

'07. 8.17 14:58
 Name:
 No. 003 VD: 13.75

-KER(P)-
 [R] mm D
 H 7.95 42.50
 V 7.79 43.37
 P(25°)
 mm D
 T 7.96 42.37
 N 8.03 42.00
 S 7.99 42.25
 I 8.02 42.12

E(H) 0.267
 E(V) 0.606
 E(AV) 0.461

[L] mm D
 H 7.89 42.75
 V 7.71 43.75
 P(25°)
 mm D
 T 7.90 42.75
 N 7.92 42.62
 S 7.94 42.50
 I 8.00 42.25

E(H) 0.190
 E(V) 0.673
 E(AV) 0.499

OFFICE NAME
 Telephone number

Radius of
 curvature at
 time of
 right-eye
 periphery
 measurement
 (tangential
 direction)

Corneal
 refractive power
 on right eye
 periphery (D)

Left eye
 center fixed
 horizontal
 value

Left eye center
 fixed vertical
 value

Radius of
 curvature at
 time of left
 eye periphery
 measurement
 (tangential
 direction)







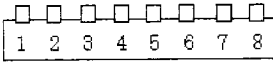

Corneal
 refractive
 power on
 left eye
 periphery
 (D)

 The measured values are always printed in order from the right to the left eye, even when the left eye was measured first.

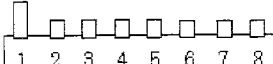
6-4 Printout (Multiple Printers)

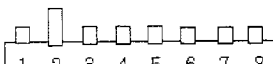
6-4-1 Using Multiple Printers

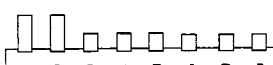
If two or more printers are available in the room, set the DIP switch of each printer as described below in order to avoid mutual interference. The ID number of each printer corresponds to the ID number of the main unit, which is set with "PRT UNIT NO." in "7-4 OUTPUT Screen" (p. 71).

ID number	DIP switch settings	Corresponding key when PRT UNIT NO. is "SELECT"
1 Factory setting		
2		
3		
4		

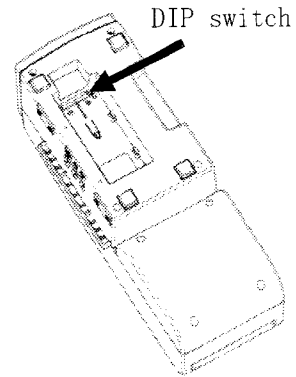

Examples of transmission from the main unit to printers

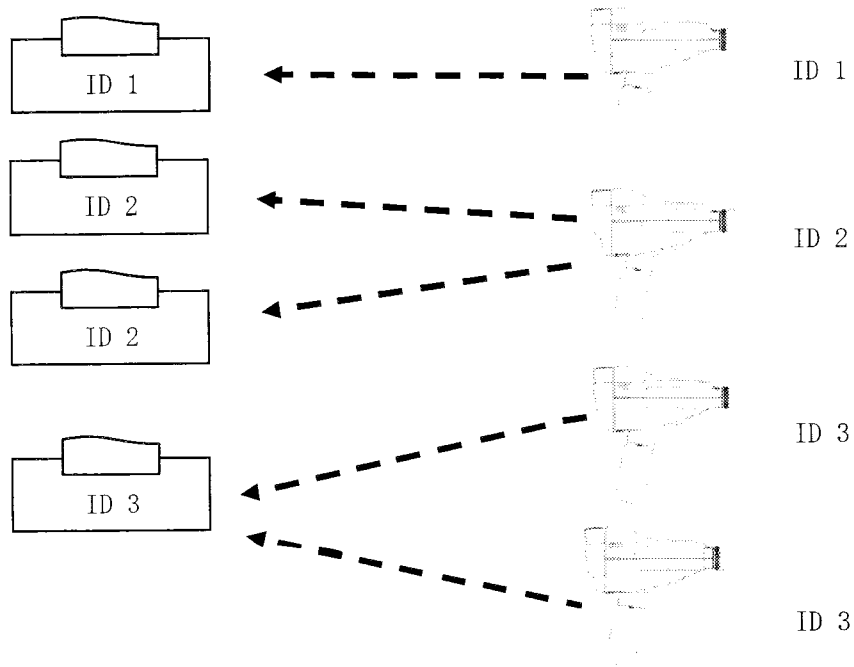

It is possible to change the ID number for each printer by setting "PRT UNIT NO." on "SELECT"

1. Set "PRT UNIT NO." to "SELECT" on "7-4 OUTPUT screen" (p. 71).
2. Perform measurement.
3.
 - When transmitting via wireless communication, aim the front side of the main unit at the light receiving window.
 - When transmitting via wired connection, connect the main unit and the printer with a direct print cable.



4. Press  key.

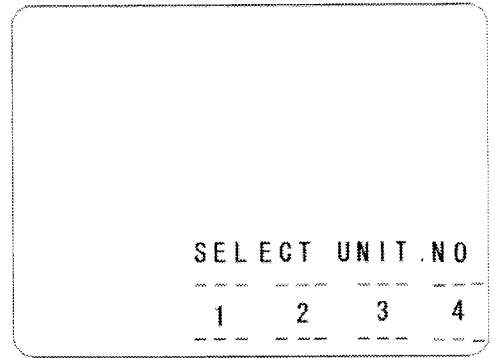

ID Number Selection screen

5. As shown on the figure on the right, the ID No. selection screen appears.
6. Press the key corresponding to the printer that will receive the data.
7. The corresponding printer will make a printout.

6-4-2 Changing the Print Format

The print format can be changed for refractive/kerato measurement values using dipswitch

8.

Print format 1 Factory setting	Print out in the following order -REF- [R] [L] -KER- [R] [L]
Print format 2	Print out in the following order -REF- [R] -KER- [R] -REF- [L] -KER- [L]

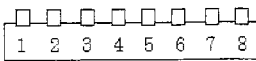
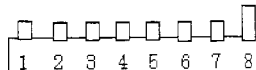
Print format	State of dipswitch = 8
1	
2	

 Before printing, make sure that the printer battery is sufficiently charged. It is necessary to restart operation in the case when the power turns off during printing.

7. Setting Up the Instrument

The main unit can be set to various conditions as shown below.



Move the cursor (▷) to the desired item, and then press

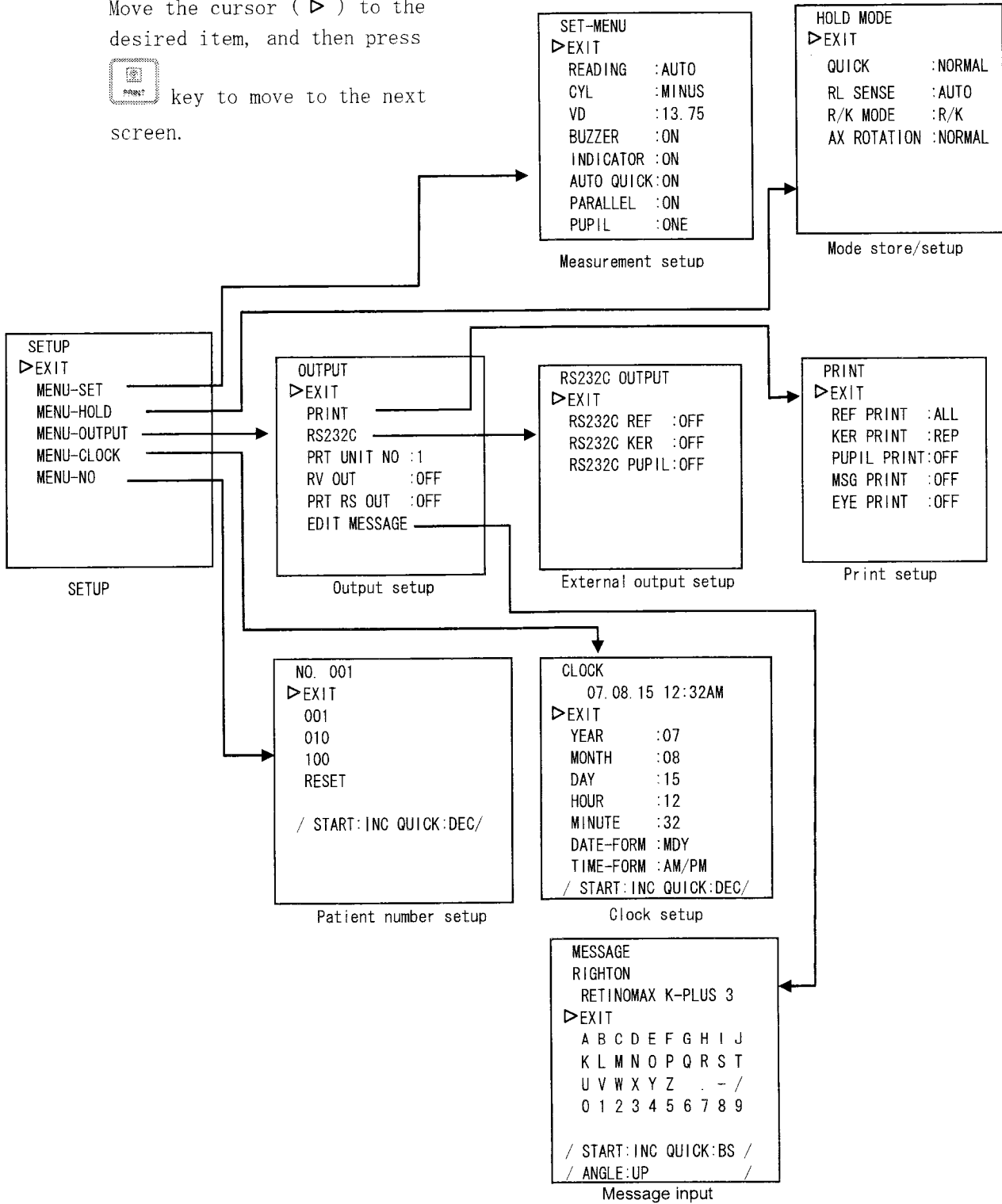

key to move to the next screen.



7-1 SETUP Screen

Press  and  keys simultaneously to display the Setup screen in the viewfinder. You can select any item displayed on the Setup screen to move to the corresponding sub-menu.

SETUP
 ▷EXIT
 MENU-SET
 MENU-HOLD
 MENU-OUTPUT
 MENU-CLOCK
 MENU-NO

■ Selecting an item

A menu item is selected when the cursor (▷) lies to its left. To move the cursor, use one of the following keys:

 key: Moves the cursor (▷) down.

 key: Moves the cursor (▷) up.

■ Moving to a sub-menu or configuring settings

For an item that has a sub-menu, press  key while the item is selected (the cursor ▷ is positioned next to the item).

For an item that has configurable settings, each press of  key displays the next configurable setting. Determine the desired setting.

The current settings displayed on the screen take effect when you exit the screen.

Item	Setting
EXIT	Moves to the measurement screen
MENU-SET	Moves to the SET-MENU screen (p. 69)
MENU-HOLD	Moves to the HOLD MODE screen (p. 70)
MENU-OUTPUT	Moves to the OUTPUT screen (p. 71)
MENU-CLOCK	Moves to the CLOCK screen (p. 75)
MENU-NO	Moves to the NO (patient number) screen (p. 76)

7-2 SET-MENU Screen -- Measurement Setup

Use this screen to configure settings that work during measurement.

See "7-1 SETUP Screen" (p.68) for instructions on selecting items and configuring settings.

SET-MENU	
▷ EXIT	
READING	:AUTO
CYL	:MINUS
VD	:13.75
BUZZER	:ON
INDICATOR	:ON
AUTO QUICK	:ON
PARALLEL	:ON
PUPIL	:ONE

Item	Selections (default setting in boldface)	Setting	
EXIT	-	Moves to the SETUP screen	
READING	AUTO	Enables automatic measurement termination	
	CONT	Disables automatic measurement termination	
CYL	MIX(±)	Disables conversion of measured CYL value	
	MINUS(-)	Converts CYL to a negative value	
	PLUS(+)	Converts CYL to a positive value	
VD	12.0	Sets corneal vertex distance (VD) in mm	
	13.5		
	13.75		
	15.0		
	16.0		
	0.0		
BUZZER	ON	Buzzer ON	Enable/disables all buzzer beeps except in setup and printing processes
	OFF	Buzzer OFF	
INDICATOR	ON	Enables the alignment direction indication function	
	OFF	Disables the alignment direction indication function	
AUTO QUICK	ON	Enables the auto quick function	
	OFF	Disables the auto quick function	
PARALLEL	ON	Enables the horizontal indication function	
	OFF	Disables the horizontal indication function	
PUPIL	ONE	Obtains one pupil diameter per eye measurement	
	ALL	Always measures pupil diameter after refractive measurement of each eye measurement	

7-3 HOLD MODE Screen -- Mode Store/Setup

Use this screen to disable some of the initial settings given at power-on time.
See "7-1 SETUP Screen" (p.68) for instructions on selecting items and configuring settings.

```

HOLD MODE
▷EXIT
QUICK      :NORMAL
RL SENSE   :AUTO
R/K MODE   :R/K
AX ROTATION :NORMAL
    
```

Item	Selections (default setting in boldface)	Setting
EXIT	-	Moves to the SETUP screen
QUICK	HOLD	On initialization, retains the previously used quick mode
	NORMAL	On initialization, disables the quick mode
RL SENSE	MANUAL	On initialization, changes to manual R/L identification
	AUTO	On initialization, enables automatic R/L identification
R/K MODE	HOLD	On initialization, retains the previously used mode.
	R/K	On initialization, enables R/F Mode
AX ROTATION	HOLD	On initialization, retains the previously used mode
	NORMAL	On initialization, disables the axis correction





7-4 OUTPUT Screen — Output Setup

Use this screen to configure the settings for output equipment.

See “7-1 SETUP Screen” (p.68) for instructions on selecting items and configuring settings.

```

OUTPUT
▷EXIT
PRINT
RS232C
PRT UNIT NO :1
RV OUT      :OFF
PRT RS OUT  :OFF
EDIT MESSAGE
    
```

Item	Selections (default setting in boldface)	Setting
EXIT	-	Moves to the SETUP screen
PRINT	-	Moves to the PRINT screen
RS232C	-	Moves to the RS232C OUTPUT screen
PRT UNIT NO. Note 1	1	Sets the device number of the printer
	2	
	3	
	4	
	SELECT	Selects the destination at each transmission
	 1	
	 2	
	 3	
	 4	
RV OUT Note 1 Note 2	ON	Enables transmission to the remote vision. (No pupil diameter)
	OFF	Disables transmission to the remote vision. (With pupil diameter)
PRT RS OUT	REF	Enables external output of measured refractive values from the printer
	R/PUP	Enables the external output of refractive values and pupil diameter values from the printer
	KER	Enables external output of keratometric values and pupil diameter values from the printer
	R/K	Enables external output of refractive values and keratometric values from the printer
	R/K/PUPIL	Enables external output of measured refractive values, keratometric values and pupil diameter values from the printer
	OFF	Disables external output from the printer
EDIT MESSAGE	-	Enables message input

Note 1. When the product is shipped from factory, the main unit, printer, and remote vision are all set to ID number “1”. If the Printer ID is set to a number other than “1” on the main unit, change the ID settings on the printer and remote vision to that number. To change the Printer ID, use the DIP switch as described in “6-4 Printout (Multiple

Printers)” (p.65). To change the setting of the remote vision ID, refer to the Remote Vision Instructions.

Note 2. RV OUT ON :Data on pupil diameter values cannot be transmitted.

PRT RS OUT is on selecting REF.

RV OUT OFF:Transmission of pupil diameter data is on user selection.

PRT RS OUT is on user selection.

7-5 PRINT Screen -- Print Setup

Use this screen to configure the settings for print output.

See "7-1 SETUP Screen" (p.68) for instructions on selecting items and configuring settings.

PRINT
▷EXIT
REF PRINT:ALL
KER PRINT:REP
PUPIL PRINT:ON
MSG PRINT:OFF
EYE PRINT:OFF

Item	Selections (default setting in boldface)	Setting
EXIT	-	Moves to the SETUP screen
REF PRINT	ALL	Prints all refractive values that are measured
	REP	Prints only representative values of measured refractive values
	OFF	Does not print measured refractive values
KER PRINT	ALL	Prints all keratometric values that are measured
	REP	Prints only representative values of measured keratometric values
	OFF	Does not print measured keratometric values
PUPIL PRINT	ON	Prints measured pupil diameter values
	OFF	Does not print measured pupil diameter values
MSG PRINT	ON	Includes a message in the printout
	OFF	Does not include a message in the printout
EYE PRINT	ON	Produces an eye print
	ON BY SW	Produces an eye printer when  key is depressed for one second or longer * At the time of stored data output, if the setting is "ON BY SW," an eye print cannot be produced
	OFF	Does not produce an eye print

7-6 RS232C OUTPUT Screen -- External Output Setup

Use this screen to configure external output settings.

See "7-1 SETUP Screen" (p.68) for instructions on selecting items and configuring settings.

RS232C OUTPUT
▷EXIT
RS232C REF :OFF
RS232C KER :OFF
RS232C PUPIL:OFF

Item	Selections (default setting in boldface)	Setting
EXIT	-	EXIT
RS232C REF	ALL	Transmits all refractive values that are measured from the main unit to external equipment via direct cable
	REP	Transmits only representative values of measured refractive values from the main unit to external equipment via direct cable
	OFF	Does not transmit measured refractive values from the main unit to external equipment
RS232C KER	ALL	Transmits all keratometric values that are measured from the main unit to external equipment via direct cable
	REP	Transmits only representative values of measured keratometric values from the main unit to external equipment via direct cable
	OFF	Does not transmit measured keratometric values from the main unit to external equipment
RS232C PUPIL	ON	Transmits measured pupil diameter values from the main unit to external equipment
	OFF	Does not transmit measured pupil diameter values from the main unit to external equipment

Note: The following settings apply to both communications from the main unit to external equipment and from the printer to external equipment.

Baud rate	9600 bps
Data bits	8 bits
Parity	None
Stop bits	2 bits





7-7 CLOCK Screen -- Time Setup

Use this screen to set the time of the internal clock and specify the date/time print format. See "7-1 SETUP Screen" (p.68) for instructions on selecting items and configuring settings.

Once the clock time is changed, it takes effect upon exiting from the CLOCK screen.

```

CLOCK
  07.08.15 12:32AM
▷EXIT
YEAR      :07
MONTH     :08
DAY       :15
HOUR      :12
MINUTE    :32
DATE-FORM :MDY
TIME-FORM :AM/PM
/ START:INC QUICK:DEC/
    
```

Item	Setting	Configuration and selections (default setting in boldface)
EXIT	Moves to the SETUP screen.	-
YEAR	Sets the year	The start switch adds one year
		 key subtracts one year
MONTH	Sets the month	The start switch adds one month
		 key subtracts one month
DAY	Sets the day	The start switch adds one day
		 key subtracts one day
HOUR	Sets the hour	The start switch adds one hour
		 key subtracts one hour
MINUTE	Sets the minute	The start switch adds one minute
		 key subtracts one minute
DATE-FORM	Changes the date print format	YMD (year/month/day)
		MDY (month/day/year)
		DMY (day/month/year)
TIME-FORM	Changes the time print format	AM/PM (12-hour system)
		24-hour system

Note. When a date or time print format is selected, the date/time display on the 2nd line of the screen changes to reflect the selection.

7-8 NO. Screen -- Patient Number Setup



Use this screen to set the patient number. The valid range is from 001 to 999.

See "7-1 SETUP Screen" (p.68) for instructions on selecting items and configuring settings.

```

NO. 001
▷EXIT
001
010
100
RESET

/ START:INC QUICK:DEC/
    
```

Item	Setting	Configuration
EXIT	Moves to the SETUP screen	-
001	Sets the 1s digit	The start switch adds one (Example: 097 → 098)
		 key subtracts one (Example: 097 → 096) Patient number 001 remains unchanged from 001
010	Sets the 10s digit	The start switch adds 10. (Example: 097 → 007)
		 key subtracts 10 (Example: 097 → 087)
100	Sets the 100s digit	The start switch adds 100 (Example: 097 → 197)
		 key subtracts 100. (Example: 097 → 997)
RESET	The start switch resets the number to 001 (Example: 097 → 001)	-

The default setting is 001.

7-9 MESSAGE Screen — Message Input





This screen adds a message to the end of the printout. Move to the message input screen.

The message can be as long as 24 characters by 2 lines, or 48 characters in total. See “7-1 SETUP Screen” (p.68) for instructions on selecting items and configuring settings, unless otherwise described below

MESSAGE
RIGHTON
RETINOMAX K-PLUS 3 ①
▷ EXIT
A B C D E F G H I J
K L M N O P Q R S T
U V W X Y Z . - / ②
0 1 2 3 4 5 6 7 8 9
/ START:INC QUICK:BS /
/ ANGLE:UP /

①	Message area
②	Selectable characters

■ How to enter and set a message

	Moves the cursor right
	Moves the cursor down
	Moves the cursor up
	Deletes the previously entered character/number
Start switch	Enters the character/number at the cursor (▷) position

Character/numbers are displayed in the message area of the screen in order as they are entered with the press of the start switch.

When the full message is entered, move the cursor to “EXIT” and press



key. The message is saved, completing the process.

8. Connecting to the Remote Vision and a Computer

The main unit and the printer have connectors for linking to external equipment. These connectors provide an interface that complies with EIA RS-232C. Measurement results can be sent via these connectors to external equipment such as a commercially available PC.

Once the Retinomax is connected with the Righton Auto Optester Remote Vision or Nikon Auto Optester OT-3A/OT-5A/OT-7A/OT-8A via wireless transmission, the measurement data can be automatically set as lens power values when starting subjective inspection using the Remote Vision Auto Optester. This speeds up the Eye Exam. For more details on this interface, contact your dealer. (p12)

◆ Wireless transmission to the Remote Vision

When the Righton Auto Optester Remote Vision is used, it can receive data wirelessly using the infrared communication feature of the Retinomax. To utilize the wireless transmission, configure the Remote Vision as though it is a Retinomax printer.

- Set “RV OUT” on “7-4 OUTPUT Screen” (p.71) to “ON”



During normal use, be sure to set the “RV OUT” setting on “7-4 OUTPUT Screen” (p.71) to “OFF”

If it is set to “ON” the settings of “7-4 OUTPUT Screen” (p.71), “7-5 PRINT Screen” (p.73) and “7-6 RS232C OUTPUT Screen” (p.74) will be ignored.

- Set the ID number which can be set with Item “PRT UNIT NO.” on the “7-4 OUTPUT Screen” (p.71), to the same number as of the “Setting for wireless communication with the Retinomax” parameter of “Communication setup” configured on the Remote Vision. (The default setting is “1”.)
Also read the instructions shipped with the Remote Vision.

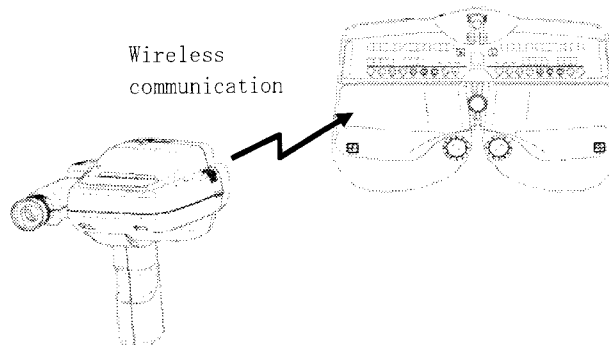

◆ **Transmission via the printer**

It is possible to transmit data from the printer to an external device. To do this, plug the optional communication cable to the communication connector on the printer.

- Set “PRT RS OUT” on the “7-4 OUTPUT Screen” (p.71) as required.

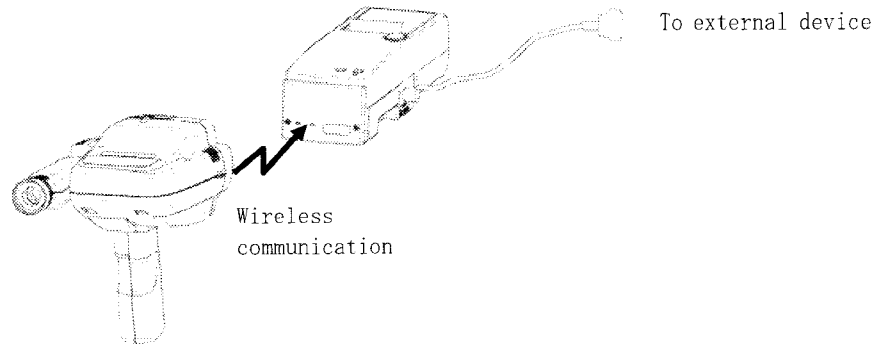

◆ **Direct communication to an external device**

It is possible to transmit data directly to an external device. To do this, plug the optional direct communication cable into the communication connector on the main unit.

- Set “7-6 RS232C OUTPUT Screen” (p.74) as required.

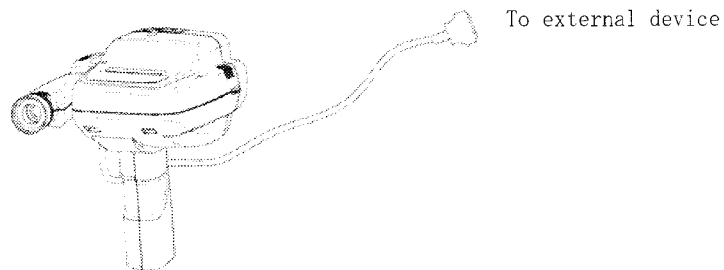

 **CAUTION**

Make sure to switch each unit's power off when connecting a communication cable.
Connecting a cable with the power on may lead to problems.

9. Maintenance

9-1 Checking the Measurement Accuracy

Before using the instrument, check the measurement accuracy of the instrument by measuring the model eye included with the Retinomax.

See Section 3, "Setup" for instructions (p.19) on measuring the model eye and checking accuracy.

9-2 Replacing the Print Roll

When the print paper nears the end of the roll, red lines appear on both edges of the paper. This indicates that it is time to replace the paper roll. (The print paper should be one designated by the manufacturer.)

1. Press the release button on the printer.

- ① Open the paper holder cover.
- ② Remove the remaining print roll.

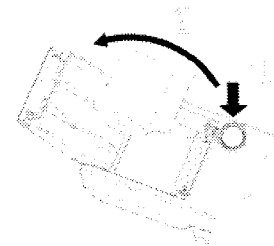

2. Remove the shipping tape from the new print roll.

3. Put a crease slightly past the peel mark.



4. Gently cut the paper along the crease. (Cutting out the paper as shown on the right prevents accidental printing on the peel mark. Also, the paper is easier to install.)

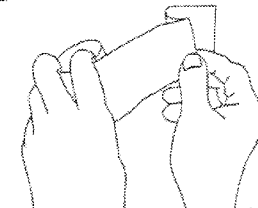

5. Set the roll along the guide, as shown on the right. The paper must be positioned as shown below.

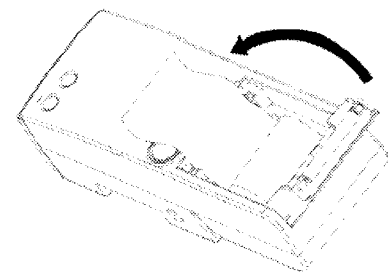
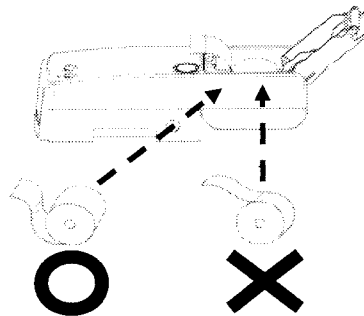
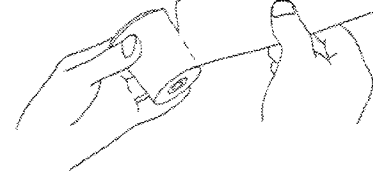

6. Press down the print roll as you close the paper holder cover.
7. Switch on the power. Press the feed button and verify that the print paper comes straight out.
If it comes out askew, remove the paper holder cover and set the roll again.



- Do not set the print roll upside down, as this makes printing impossible.
- Once the roll is set in place, do not force the paper out. Damage to the printer may occur.

9-3 Replacing the Fuses



CAUTION

Before checking or replacing the fuses, be sure to turn off the power switch and remove the power cord from the receptacle outlet.

Only use fuses as specified below. Other fuses must NOT be used. For spare fuses, contact your local dealer.

Littelfuse's time-lag fuse, $\phi 5 \times 20$ mm
250 V, 500 mA (218.500XP)

If the power lamp does not light up when the power switch of the station is set to ON ("I" position), the fuses may have blown.

Remove the fuse holder by applying a small flat-blade screwdriver or other tool to the tabs on both sides of the fuse holder.

Remove the two fuses from the fuse holder and check if they have blown. Replace the fuses if blown.

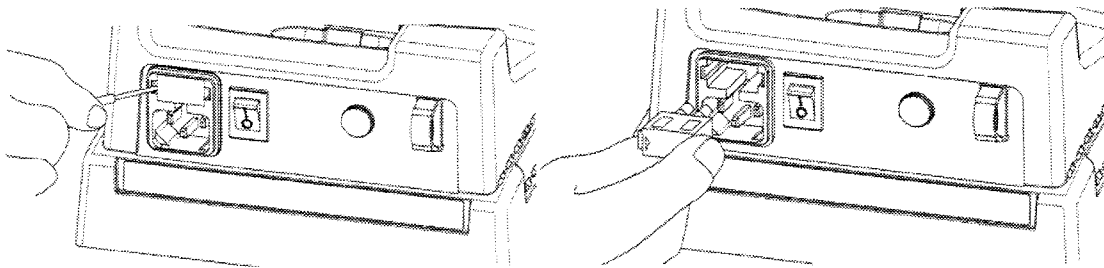

9-4 Cleaning the Forehead Rest

Clean the forehead rest periodically. Wipe off the surfaces using a soft cloth or tissue paper moistened with absolute alcohol (commercial product) or rubbing alcohol.

9-5 Cleaning the Measuring Window

The measuring window has dust-proof glass. If any dust on the glass is visible from the patient side, blow off the dust three to four times using the blower provided. If the dust cannot be removed, wipe off using a lens cleaning solution or absolute alcohol (commercial product).

Do not put heavy pressure on the dust-proof glass during wiping since the glass is thin and easily broken.

9-6 Cleaning the Model Eye

When correct measured values cannot be obtained with the model eye, its lens surface may have been contaminated by dust or fingerprints. In this case, gently wipe the lens surface using a soft, clean cotton cloth (such as gauze) moistened slightly with lens cleaning solution or absolute alcohol, being careful not to scratch the surface.

(Do not use a handkerchief or absorbent cotton.)

Even a microscopic scratch on the lens surface of the model eye can reduce the accuracy of its measurement. Do not bump or throw any hard object against the model eye as this may cause damage.

9-7 Appearance Maintenance

Do not use organic solvent (alcohol, ether, paint thinner, etc.) on painted surfaces, plastic components, and printed surfaces. It may cause discoloration, or the peeling of printed characters. Wipe off stubborn stains lightly with a gauze moistened slightly with diluted neutral detergent.

9-8 List of Consumable and Maintenance Parts

Part name	Part number	Remarks
Print paper rolls (5)		
Battery pack	RT-121	Lithium ion battery
Fuses (Littelfuse's time-lag fuses)	218.500XP	Rating For 250 V, 500 mA Size: $\phi 5$ x 20 mm

10. Troubleshooting

- If any problems occur, check with the following table before calling for repair.

■ 1. Main unit

Phenomenon	Check point	Cause and action
The power lamp does not light when Retinomax is turned on. The monitor screen does not turn on.	If operated from battery power, it is likely that the battery pack has been fully discharged.	The battery pack is not charged when purchased. It may be fully discharged if Retinomax is not used for a long time. Charge the battery pack.
The power switches off automatically.	Has the main unit been left inoperative for more than 3 minutes?	The power switches off automatically if the instrument is left inoperative for 3 minutes.
	Is the remaining battery charge sufficient?	When the remaining battery charge is insufficient, the power switches off automatically (See "4-8-2 Battery Low Indication" [p.46])
	Are the battery charging contacts dirty? (p.15)	Turn the power off, and clean the pins both on the main unit and the station sides.
The battery pack cannot be installed in the main unit.	Is the battery pack in the correct orientation?	Check to make sure the battery pack is correctly installed. (See "3-2-1 Installing and Removing the Main Unit Battery Pack" [p.19])
Keratometric measurement cannot be made. Keratometric measurements vary widely.	Is there interference from external light?	Darken the room. Do not face the window during measurements.
	Is the eyelid interfering with measurements?	Raise the eyelid.
Refractive measurement cannot be made. Refractive measurements vary widely.	Is the measurement out of range? Is there foreign matter in the pupil that obstructs light?	Check in the retroillumination mode. (p.60)

- Note regarding the battery packs included with the instrument
This instrument comes with a lithium ion battery, RT-121, which is equipped with a clock function and various setup memory functions. When the battery runs down, the time or date of printing of measured values may change, and each setup function will not be stored into memory, leading to a return to default settings whenever the power is turned off. When the battery pack in the instrument runs down, the indication as shown on the right will appear after the opening screen.
If such an indication appears, please contact your local dealer.

BACK UP ERROR 1
BACK UP ERROR 2

Indication of battery pack exhaustion

■ 2. Station

Phenomenon	Check point	Cause and action
The charge lamp flashes during charging.	Try reconnecting the main unit or printer according to the flow chart below.	If the problem persists after a check, contact your local dealer.

● Check Flashing of the Charging Lamp

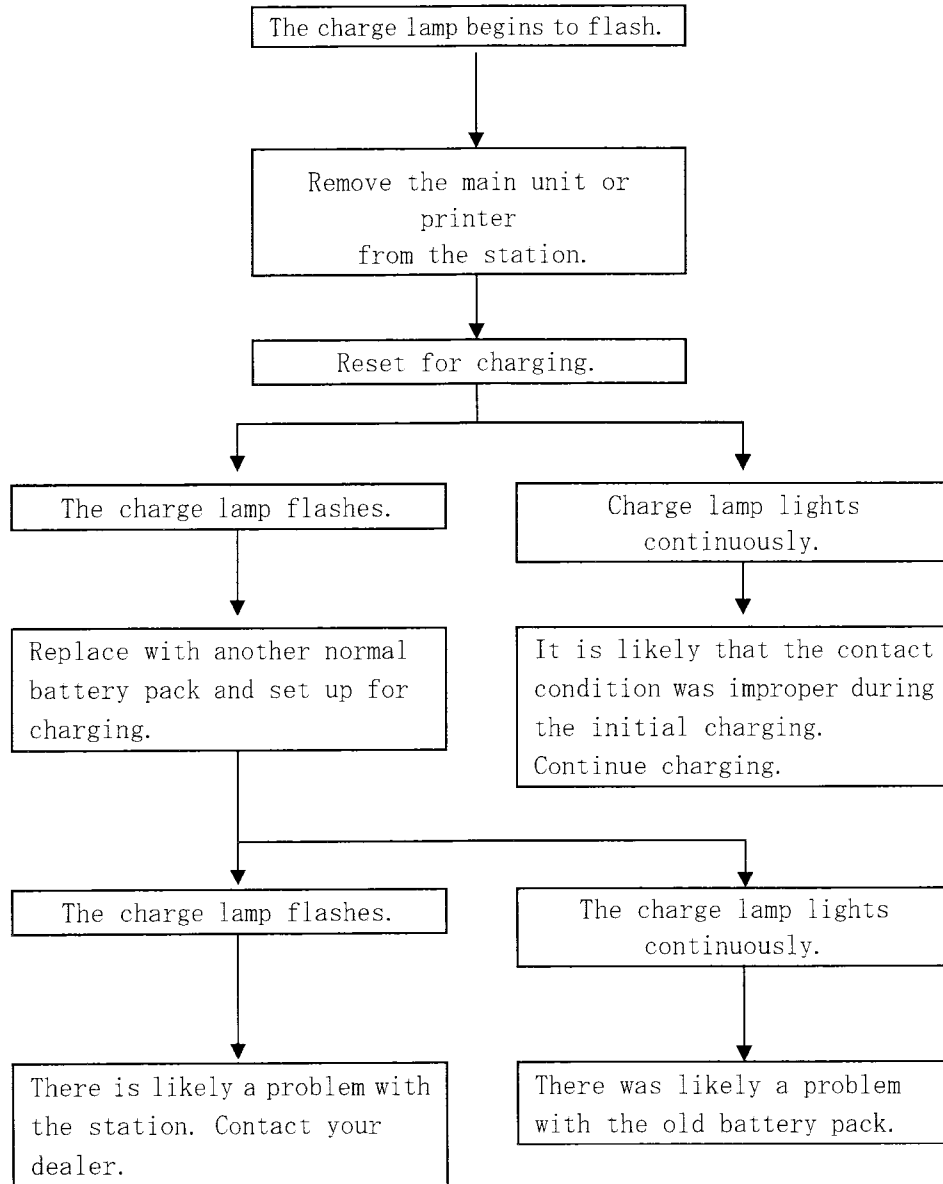

■ 3. Printer

Phenomenon	Check point	Cause and action
The printer connected to the station does not turn on when the printer power switch is flipped on.	Is the printer correctly connected to the station?	Correct the connection. (See "3-4-2 Automatic Charging of the Printer" [p.23].)
	Is the station in a power-off state?	The printer will not operate if the station is not turned on. Turn on the station.
The battery pack is set in the printer, but the power lamp does not light when the power switch is set to on.	Is the battery pack in the correct orientation?	Check that the battery pack is correctly installed. (See "3-2-2 Installing and Removing the Printer Battery Pack" [p.20].)
	Is the battery lamp flashing or lit in yellow?	Recharge the battery pack. (See "3-4 Charging the Battery pack" [p.22].)
The printer power lamp flashes.	Is the battery lamp flashing or lit in yellow?	Recharge the battery pack. (See "3-4 Charging the Battery pack" [p.22].)
	Is the print roll set correctly? (Beeps if not correctly set.)	Set the print roll correctly. (See "9-2 Replacing the Print Roll" [p.80].)
	Is the paper holder cover open? (Beeps if not correctly set.)	Close the paper holder cover.
The buzzer beeps repeatedly.	Is the print roll set correctly?	Set the print roll correctly. (See "9-2 Replacing the Print Roll" [p.80].)
	Is there a problem with the RS-232C connection to the external device or a problem with the external device?	Check that the communication cable is properly connected on both ends. Carefully read the instructions of the external device.
Nothing prints.	Are you using the designated print roll?	Use the designated print roll.
	Is the paper holder cover open?	Close the paper holder cover.
	Is the paper roll inserted upside down?	Set the print roll correctly. (See "9-2 Replacing the Print Roll" [p.80].)

The printer does not receive measurement data sent from the main unit.	Are there any obstacles between the main unit and printer?	Remove the obstacles, or move to a location free of obstacles.
	Is the printer too far away from the main unit?	Data can be transmitted to a location within 6 meters from the printer and with an angle of less than 45 degrees between the front side of the main unit and the light receiving window of the printer.
	Is the ID number of the printer same as that of the main unit?	Match the ID numbers by checking the OUTPUT screen and the DIP switch in the printer. (See "6-4-1 Using Multiple Printers" [p.65])
Characters are crowded on the print paper. The paper does not come out properly.	Is the print roll set correctly?	Set the print roll correctly. (See "9-2 Replacing the Print Roll" [p.80].)
	Are there red lines on the edges of the print paper?	Replace the print roll. (See "9-2 Replacing the Print Roll" [p.80].)

11. Specifications

< Name >

Righton Hand Held Auto refract Keratometer

Retinomax K-plus 3

< Measurement >

▼ Refractive measurement

Measurement range: S+C: -18D to +23D (for VD value of 12)
C: 0D to -12D, or 0D to +12D
AX: 1° to 180°
Measurement step: S and C: 0.25D
AX: 1°
Minimum pupil diameter: ϕ 2.3 mm
Measurement wavelength: Approx. 860 nm

▼ Keratometric measurement

Measurement range: Curvature: 5 mm to 11 mm (67.5D to 30.682D)
Corneal astigmatism 0D to -12D
Measurement step: Curvature 0.01 mm
Corneal astigmatism 0.12D
Cylinder axis 1°
Measurement area: Center 23°, ϕ 3.2 (at R of 8 mm)
Peripheral 50°, ϕ 6.8 (at R of 8 mm)

▼ Pupil diameter

Measurement range: 2.0 mm to 10.0 mm
Measurement step: 0.1 mm

▼ Common to refractive and keratometric measurement (measurement time and mode)

R-K mode: Continuous measurement R/K
R/PUPIL
R/PUPIL/K
Single measurement R, K
Measurement time Refractive Data acquisition time per measurement
0.017 sec.
Keratometric Data acquisition time per measurement
0.034 sec.
Pupil diameter Data acquisition time per measurement
0.274 sec.
Measurement time for continuous measurement
• R/K continuous measurement: 0.338 sec./measurement
• R/PUPIL continuous measurement: 0.412 sec./measurement
• R/PUPIL/K continuous measurement: 0.612 sec./measurement
• R single measurement: 0.138 sec./measurement
• K single measurement: 0.200 sec./measurement

Measurement modes: Automatic measurement: Auto start, auto stop
 Continuous measurement: Auto start, followed by continuous measurement
 Quick measurement: Measurement has priority over fogging, resulting in faster refractive measurement.

Fixation target: Tulip, Rocket, Bear
 Fixation target illumination: Changeable between two illuminance levels
 Alignment aiming: 18-dot LED illumination, $\phi 2.6$ mm (at R of 8 mm)
 Retroillumination : Pressing the RTR0 key turns off extraocular illumination and alignment mark indications, enabling observation of opacity and scars in optic media of patient's eye.
 Corneal vertex distance: 0, 12, 13.5, 13.75, 15, and 16 mm
 Right/left eye identification: Auto/manual (switchable)

- ▼ **Memory function** Data on 50 persons (100 eyes) at maximum storable
- ▼ **Power saving function** Power switches off automatically after 3 minutes in standby state

< **Main unit, etc.** >

Main-unit dimensions: 170(W) x 240(D) x 230(H) mm
 Weight: 899 g (without battery)
 999 g (with battery)
 Realtime clock: Built-in realtime clock for date/time printing
 Monitor: 0.2-inch color viewfinder
 Input: RS232C interface (external connector)
 Output: Infrared communication, external computer
 RS232C interface (external connector)
 NTSC video output
 Melody sound: Possible (not during measurement)
 Print message: Possible
 Power source: Input DC8.2V 1.0A
 Charging DC8.4V 1.1A

▼ **Station**

Battery charging: Automatic charging
 Power consumption: 0.4A
 Fuses: Littelfuse's time-lag fuses
 Rating: 250 V, 500 mA (218.500XP)
 Size: $\phi 5$ x 20 mm
 Weight: 1360 g
 Dimensions: 185(W) x 101(H) x 263(D) mm

▼ Printer

Print paper width: 58 mm
Drive: Powered from the station (when docked with the station)
Battery drive (when separated from the station and a battery pack is installed)
Battery: Lithium ion battery (RT-121)
Working time: 80 minutes on a full charge
Charging time: 120 minutes max.
Input: Infrared communication, RS232C
Output: RS232C
Weight: 595 g (without battery)
Dimensions: 100(W) x 81(H) x 263(D) mm
Eye print diagram: Possible
Power source: Input DC7.4V 1.2A
Charging DC8.4V 1.1A

▼ Battery pack

Battery: Lithium ion battery (RT-121)
Nominal voltage: 7.4 VDC
Nominal capacity: 1.7A
Weight: Approx 100 g
Dimensions: 37.6(W) x 20.4(H) x 71.6(D) mm

Authorization to apply the UL mark (File E255797)



UL 60601-1, 1st Edition, 2006-04-26

(Medical Electrical Equipment, Part 1: General Requirements for Safety)

CAN/CSA-C22.2 No. 601.1-M90, 2005

(Medical Electrical Equipment – Part 1: General Requirements for Safety)



CAUTION

Information on the avoidance of overexposure to optically hazardous optical radiation(ISO 15004: 1997)

Spectrally weighted photochemical radiances L_B and L_A give a measure of the potential that exists for a beam of light to cause photochemical hazard to the retina. L_B gives the measure for eyes in which the crystalline lens is in place. L_A gives this measure either for eyes in which the crystalline lens has been removed (aphakes) and has not been replaced by a UV-blocking lens or for the eyes of very young children.

The value stated for Retinomax 3, Retinomax K-plus 3 gives a measure of hazard potential when the instrument is operated at maximum intensity and maximum aperture. Values of L_B or L_A over $80 \text{ mW}/(\text{cm}^2 \cdot \text{sr})$ are considered high for beams which wholly fill a dilated pupil.

The values of L_A or L_B for the Retinomax 3, Retinomax K-plus 3 are sufficiently low as shown on the following page.

The retinal exposure dose for a photochemical hazard is a product of the radiance and the exposure time. For instance, at a radiance level of $80 \text{ mW}/(\text{cm}^2 \cdot \text{sr})$, 3 min irradiation of the dilated (8mm diameter) pupil would cause the retinal exposure dose level to attain the recommended exposure limit. If the value of radiance were reduced to $40 \text{ mW}/(\text{cm}^2 \cdot \text{sr})$, twice that time (i.e. 6 min) would be needed to reach the recommended limit. The recommended exposure does is based on calculations arising from the American Conference of Governmental Industrial Hygienists(ACGIH) – Threshold Limit Values for Chemical Substances and Physical Agents (1995-1996 edition).

The following page shows the graph of spectrum output for the Retinomax 3, Retinomax K-plus 3. Patients will be at low risk of acute optical radiation with the Retinomax 3, Retinomax K-plus 3. However, it is recommended that the intensity of light directed into the patient's eye be limited to the minimum level which is necessary for diagnosis. The total of the retinal exposure dose must be carefully watched for infants, aphakes and persons with diseased eyes who are at greater risk when other ophthalmic devices with a high level of radiance are used in conjunction.



**Spectrum output of all light source during refract measurement
(maximum light intensity)**

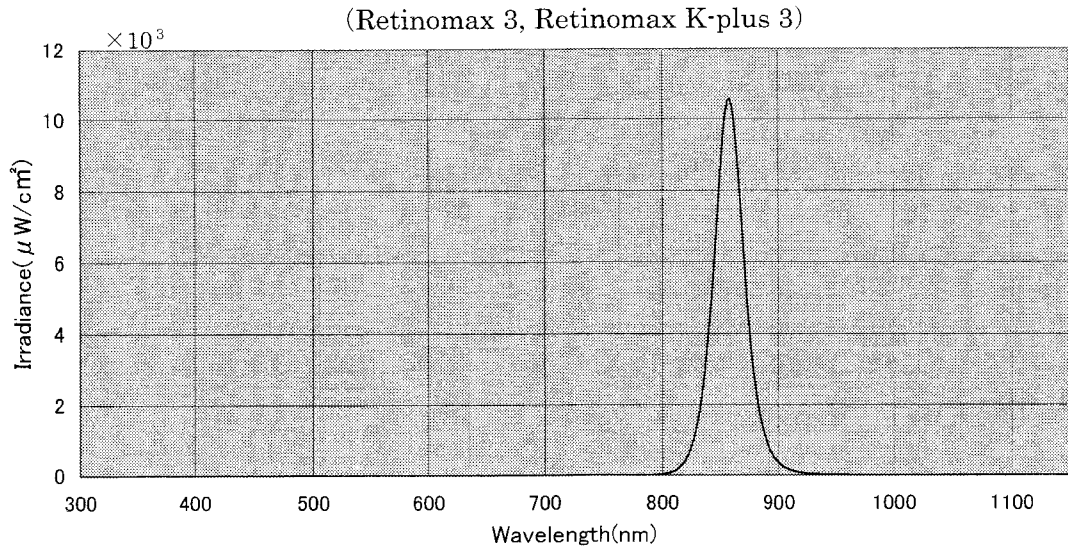

Radiance

- *1 LA 380~700nm 378($\mu W/cm^2 \cdot sr$)
- *2 LB 305~700nm 307($\mu W/cm^2 \cdot sr$)

**Spectrum output of all light source during kerato measurement
(maximum light intensity)**

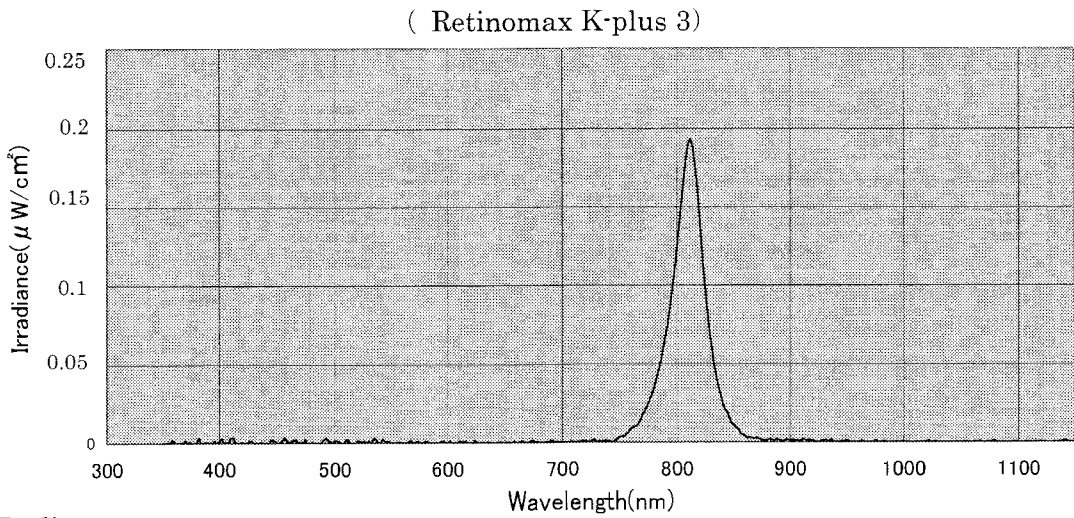

Radiance

- *1 LA 380~700nm 0.138($\mu W/cm^2 \cdot sr$)
- *2 LB 305~700nm 0.174($\mu W/cm^2 \cdot sr$)

*1 LA: Spectrally weighted photochemical aphakic source radiance

*2 LB: Spectrally weighted photochemical phakic source radiance

Patient environment

The patient environment represents a space where there is a possibility of direct contact between the patient or the operator and third person.

When another type of device is used in the patient environment, use a device that complies with IEC 60601-1-1. If the devices that do not comply with IEC 60601-1-1 are used, it is necessary to use an isolating transformer to power the device or to connect the devices to additional protective grounding.

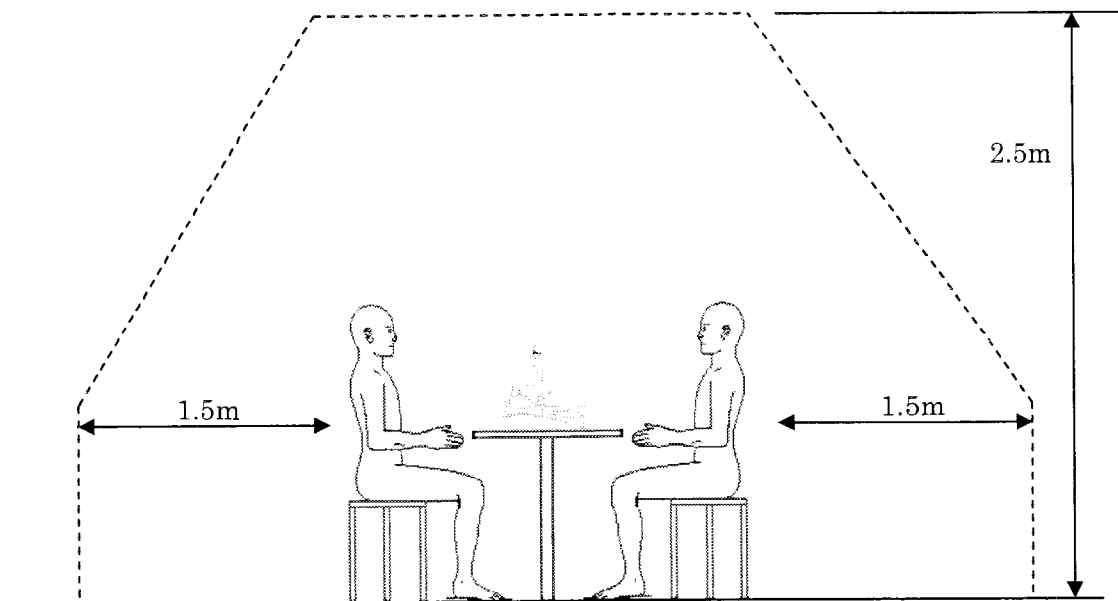
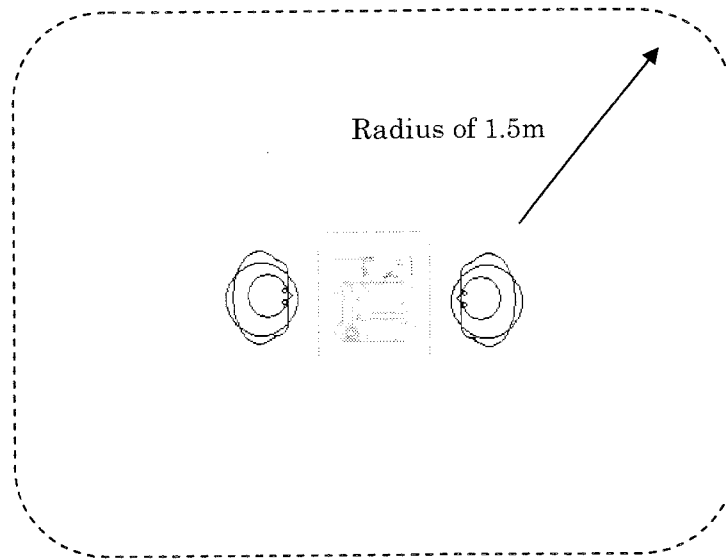



Information of EMC(Electro Magnetic Compatibility)

- Retinomax 3, Retinomax K-plus 3 complies with the limits for medical devices in IEC 60601-1-2:2001, EN 60601-1-2:2001, and Medical Device Directive 93/42/EEC. These limits are designed to provide reasonable protection against harmful interference in a standard medical installation. Retinomax 3, Retinomax K-plus 3 generates, uses and can radiate radio frequency energy and, if not installed and used in accordance with the instructions, may cause harmful interference to other devices in the vicinity. However, there is no guarantee that interference will not occur in a particular installation. If the device does cause harmful interference to other devices, which can be determined by turning the device off and on, the user is encouraged to try to correct the interference by one or more of the following measures:
 - 1 . Reorient or relocate the receiving device.
 - 2 . Increase the distance to the device.
 - 3 . Correct the device into an outlet on a circuit different from that to which the other device(s) are connected.
 - 4 . Consult the manufacturer or field service technician for assistance.

- In installation and operation of the device, observe the following instructions about EMC(electromagnetic compatibility):
 - 1 . Do not use the device simultaneously with other electronic equipment to avoid electromagnetic interference with the operation of the device.
 - 2 . Do not use the device near, on, or under other electronic equipment to avoid electromagnetic interference with the operation of the device.
 - 3 . Do not use the device in the same room with other equipment such as life-support equipment, other equipment that has major affects on the life of the patient and results of treatment, or other measurement or treatment equipment that involves small electric current.
 - 4 . Do not use the device simultaneously with portable and mobile radio frequency communication systems because it may have an adverse effect on operation of the device.
 - 5 . Do not use cables and accessories that are not specified for the device because that may increase the emission of electromagnetic waves from the device or the system and decrease the immunity of the device to electromagnetic disturbance.

EMC (Electromagnetic Compatibility)

The Electromagnetic Compatibility Directive sets the essential requirements for electrical and electronic equipment that may disturb or even be disturbed by other equipment. The Retinomax 3, Retinomax K-plus 3 complies with these requirements as tabled below. Follow the guidance on the tables for use of the device in the electromagnetic environment.

EMC(IEC60601-1-2:2001)

Guidance and manufacturer's declaration – electromagnetic emissions		
Retinomax 3, Retinomax K-plus 3 are intended for use in the electromagnetic Environment specified below. The customer or the user of the Retinomax 3, Retinomax K-plus 3 should assure that they are used in such an environment.		
Emissions test	Compliance	Electromagnetic environment - guidance
RF emissions CISPR 11	Group 1	Retinomax 3, Retinomax K-plus 3 uses RF energy only for its internal function. Therefore, its RF emissions are very low and are not likely to cause any interference in nearby electronic equipment.
RF emissions CISPR 11	Class B	Retinomax 3, Retinomax K-plus 3 are suitable for use in all establishments, including domestic establishments and those directly connected to the public low-voltage power supply network that supplies buildings used for domestic purposes.
Harmonic emissions IEC 61000-3-2	Class A	
Voltage fluctuations/Flicker emissions IEC 61000-3-3	Complies	

Guidance and manufacturer's declaration – electromagnetic immunity			
Retinomax 3, Retinomax K-plus 3 are intended for use in the electromagnetic environment specified below. The customer or the user of the Retinomax 3, Retinomax K-plus 3 should assure that they are used in such an environment.			
Immunity test	IEC 60601 test level	Compliance level	Electromagnetic environment – guidance
Electrostatic Discharge(ESD) IEC 61000-4-2	$\pm(2,4,6)$ kV contact $\pm(2,4,8)$ kV air	$\pm(2,4,6)$ kV contact $\pm(2,4,8)$ kV air	Floors should be wood, concrete or ceramic tile. If floors are covered with synthetic material, the relative humidity should be at least 30%.
Electrical fast Transient/burst IEC 61000-4-4	± 2 kV for power supply lines ± 1 kV for input/output lines	± 2 kV for power supply lines ± 1 kV for input/output lines	Mains power quality should be that of a typical commercial or hospital environment.
Surge IEC 61000-4-5	± 1 kV differential mode ± 2 kV common mode	± 1 kV differential mode ± 2 kV common mode	Mains power quality should be that of a typical commercial or hospital environment.
Voltage dips, short interruptions and voltage variations on power supply input lines IEC 61000-4-11	$< 5\% UT$ ($>95\%$ dip in UT) For 0,5 cycle $40\% UT$ (60% dip in UT) For 5 cycles $70\% UT$ (30% dip in UT) For 25 cycles $<5\% UT$ ($>95\%$ dip in UT) For 5 sec	$< 5\% UT$ ($>95\%$ dip in UT) For 0,5 cycle $40\% UT$ (60% dip in UT) For 5 cycles $70\% UT$ (30% dip in UT) For 25 cycles $<5\% UT$ ($>95\%$ dip in UT) For 5 sec	Mains power quality should be that of a typical commercial or hospital environment. If the user of the Retinomax 3, Retinomax K-plus 3 requires continued operation during power mains interruptions, it is recommended that the Retinomax 3, Retinomax K-plus 3 be powered from an uninterruptible power supply or a battery.
Power frequency (50/60 Hz) Magnetic field IEC 61000-4-8	3 A/m	3 A/m	Power frequency magnetic fields should be at levels characteristic of a typical location in a typical commercial or hospital environment.
NOTE UT is the a.c. mains voltage prior to application of the test level.			

Guidance and manufacturer's declaration – electromagnetic immunity			
Retinomax 3, Retinomax K-plus 3 are intended for use in the electromagnetic environment specified below. The customer or the user of Retinomax 3, Retinomax K-plus 3 should assure that they are used in such an environment.			
Immunity test	IEC 60601 test level	Compliance level	Electromagnetic Environment-guidance
Conducted RF IEC 61000-4-6	3 Vrms 150 kHz to 80 MHz	3 Vrms	Portable and mobile RF communications equipment Should be used no closer to any part of Retinomax 3, Retinomax K-plus 3 including cables, than the recommended separation distance calculated from the equation applicable to the frequency of the transmitter. Recommended separation distance $d = 1,2\sqrt{P}$ $d = 1,2\sqrt{P}$ 80 MHz to 800 MHz $d = 2,3\sqrt{P}$ 800 MHz to 2.5 GHz
Radiated RF IEC 61000-4-3	3 V/m 80 MHz to 2.5 GHz	3 V/m	Where <i>P</i> is the maximum output power rating of The transmitter in watts (W) according to the transmitter manufacturer and <i>d</i> is the recommended separation distance in meters(m). Field strengths from fixed RF transmitters, as Determined by an electromagnetic site survey, ^a should be less than the compliance level in each frequency range. ^b Interference may occur in the vicinity of equipment Marked with the following symbol: 
NOTE 1 At 80 MHz and 800 MHz, the higher frequency range applies. NOTE 2 These guidelines may not apply in all situations. Electromagnetic propagation is affected by absorption and reflection from structures, objects and people.			
^a Field strengths from fixed transmitters, such as base stations for radio (cellular/cordless telephones and land mobile radios, amateur radio, AM and FM radio broadcast and TV broadcast cannot be predicted theoretically with accuracy. To assess the electromagnetic environment due to fixed RF transmitters, an electromagnetic site survey should be considered. If the measured field strength in the location in which Retinomax 3, Retinomax K-plus 3used exceeds the applicable RF compliance level above, Retinomax 3, Retinomax K-plus 3 should be observed toverify normal operation. If abnormal performance is observed, additional measures may be necessary, such as reorienting or relocating Retinomax 3, Retinomax K-plus 3.			
^b Over the frequency range 150 kHz to 80 MHz, field strengths should be less than 3 V/m.			

Recommended separation distances between portable and mobile RF communications equipment and the Retinomax 3, Retinomax K-plus 3			
The Retinomax 3, Retinomax K-plus 3 is intended for use in an electromagnetic environment in which radiated RF disturbances are controlled. The customer or the user of the Retinomax 3, Retinomax K-plus 3 can help prevent electromagnetic interference by maintaining a minimum distance between portable and mobile RF communications equipment(transmitters)and the Retinomax 3, Retinomax K-plus 3 as recommended below, according to the maximum output power of the communications equipment.			
Rated maximum output power of transmitter W	Separation distance according to frequency of transmitter m		
	150kHz to 80MHz $d = 1.2\sqrt{p}$	80MHz to 800MHz $d = 1.2\sqrt{p}$	800MHz to 2.5Hz $d = 2.3\sqrt{p}$
0.01	0.12	0.12	0.23
0.1	0.38	0.38	0.73
1	1.2	1.2	2.3
10	3.8	3.8	7.3
100	12	12	23
For trans mitters rated at a maximum output power not listed above, the recommended separation distance <i>d</i> in meters'(m) can be estimated using the equation applicable to the frequency of the transmitter, where <i>P</i> is the maximum o utput power rating of the transmitter in watts(W) according to the transmitter manufacturer. NOTE 1 At 800MHz and 800MHz, the separation distance for the higher frequency range applies. NOTE 2 these guidelines may not apply in all situations. Electromagnetic propagation is affected by absorption and Reflection from structures, objects and people.			

RIGHT MFG. CO., LTD.

1-47-3, Maenochō, Itabashi-ku, Tokyo, 174-8633 Japan

tel: +81-3-3960-2275 Fax: +81-3-3960-2285

TOHOKU RIGHT MFG. CO., LTD.

OPHTHALMIC SERVICE

45-1 Aza-yashikimae, Nakamura Ohsato-cho, Kurokawa-gun, Miyagi 981-3521, Japan

tel: +81-22-359-3113 Fax: +81-22-359-3213