

## Dräger-Vapor® 19.n

### Anaesthetic Vaporiser

Instructions for Use



In order to make it very clear which Instructions for Use is to be used with each Vapor, the serial number of the Vapor assigned is printed on the back of these Instructions for Use. Instructions for Use without such a number are issued purely for information purposes and not for actual use with a Vapor. The serial number is stamped on the nameplate of the Vapor.

These Instructions for Use apply to Dräger-Vapors® 19.1, 19.2 and 19.3, known collectively as Dräger-Vapor® 19.n. When the term Vapor is used in this document it applies to all Dräger-Vapor® 19.n models, but when differences are being described, the relevant model numbers are given.

## Contents

<b>For Your Safety and That of Your Patients</b> .....	3	<b>Description</b> .....	31
<b>Intended Use</b> .....	4	Operating principle.....	31
<b>Method of Operation</b> .....	5	Calibration.....	32
<b>Preparation</b> .....	8	Influence of temperature.....	33
Before first operation.....	8	Influence of flow.....	34
Filling Vapor.....	9	Influence of gas composition.....	35
Vapor with key-indexed filling system.....	10	Influence of atmospheric pressure.....	36
Vapor with filling spout.....	13	Influence of fluctuations in pressure.....	37
Connecting Vapor.....	14	Influence of positive/negative pressure.....	37
Vapor to plug-in system.....	14	Influence of running time.....	38
Vapor without Interlock .....	15	Behaviour when tilted.....	39
<b>Operation</b> .....	16	Mechanical stress.....	39
Checks before starting anaesthesia.....	16	Key-indexed filling system.....	40
Setting concentration of anaesthetic agent.....	17	List of models/options for connection.....	42
Use with scanner.....	17	Vapor connecting systems .....	44
Use when at an angle.....	17	<b>Order List</b> .....	45
Shut-down.....	18	<b>Index</b> .....	46
Disconnecting Vapor from plug-in system.....	18		
Draining Vapor.....	19		
Vapor with key-indexed filling system.....	19		
Vapor with filling spout.....	21		
Storage.....	21		
<b>Care</b> .....	22		
Cleaning.....	22		
Disinfecting.....	23		
Checking concentration.....	24		
<b>Maintenance Intervals</b> .....	26		
<b>Technical Data</b> .....	27		
<b>What's What</b> .....	30		

## **For Your Safety and that of Your Patients**

### **Strictly follow the Instructions for Use**

Any use of the apparatus requires full understanding and strict observation of these instructions.

The apparatus is only to be used for purposes specified here.

### **Maintenance**

The apparatus must be inspected and serviced regularly by trained service personnel at six monthly intervals (and a record kept).

Repair and general overhaul of the apparatus may only be carried out by trained service personnel.

We recommend that a service contract be obtained with DrägerService and that all repairs also be carried out by them.

Only authentic Dräger spare parts may be used for maintenance.

Observe chapter "Maintenance Intervals".

### **Accessories**

Do not use accessory parts other than those in the order list.

### **Liability for proper function or damage**

The liability for the proper function of the apparatus is irrevocably transferred to the owner or operator to the extent that the apparatus is serviced or repaired by personnel not employed or authorized by DrägerService or if the apparatus is used in a manner not conforming to its intended use.

Dräger cannot be held responsible for damage caused by non-compliance with the recommendations given above.

The warranty and liability provisions of the terms of sale and delivery of Dräger are likewise not modified by the recommendations given above.

Dräger Medizintechnik GmbH

## Intended Use

Dräger-Vapor® 19.n – an anaesthetic vaporiser for accurately-controlled enrichment of fresh gas with the vapour of the relevant liquid anaesthetic agent: Isoflurane or Halothane or Enflurane or Sevoflurane.

**Only fill Vapor with the anaesthetic agent for which it is designed.**

If the wrong anaesthetic agent is used the patient may be harmed.

The Vapor is inserted into the fresh gas line leading to the breathing system of an inhalation anaesthetic machine which has a continuous flow of fresh gas.

**Do not connect Vapor downstream of the fresh gas outlet on an anaesthetic machine.**

**Do not use Vapor in the breathing system.**

**Use only dry, pure medical gases.**

Before connecting a Vapor® 19.n to other manufacturers' anaesthetic machines or operating it outside the range of uses specified in the "Technical Data" it is essential to consult Dräger Medizintechnik GmbH to check whether the connection parameters required for it to function properly (for instance, geometry, pressure and flow) will be met.

**Any deviations from the connection parameters required may result in an incorrect concentration being delivered.**

**Handle Vapor with care. Do not drop.**

**Do not carry by the handwheel or locking lever.**

Vapor models:

The model numbers 19.1, 19.2 and 19.3 which apply to otherwise identical machines refer to different types of connections:

19.1 connection without Interlock

19.2 connection to Interlock 1

19.3 connection to Interlock 2

## Method of Operation

### Handwheel

to adjust the concentration between 0.2 (0.3) vol.% and maximum concentration (depending on type).  
The handwheel is locked in the zero setting and can be freed by pressing »0« button.

Setting concentration:

- 1 **Press** »0« button and
- 2 turn handwheel anti-clockwise to concentration of anaesthetic agent required.

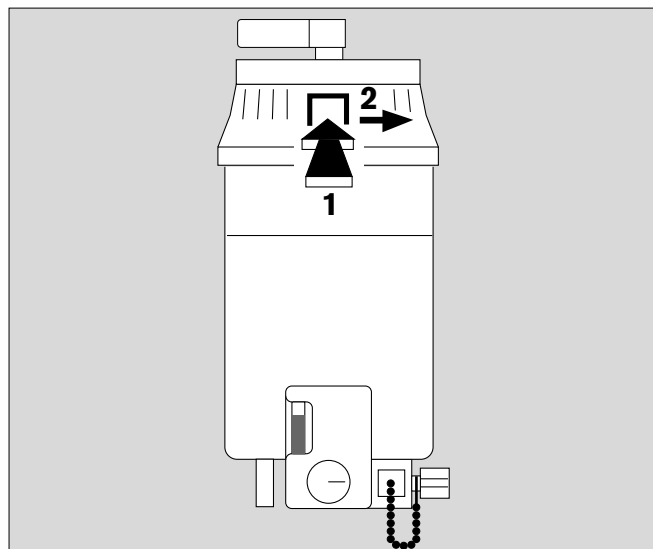

### Plug-in system

to connect and exchange the Vapor quickly and safely.

The Vapor has a permanently fixed plug-in adaptor with holes which fit over the pins on the plug-in system on the anaesthetic machine. The adaptor is secured with a locking lever.

- 3 The sealing rings become leak-tight when they are pressed down on the pin by the weight of the Vapor.

Vapor 19.3 and Vapor 19.1 require different plug-in adaptors.

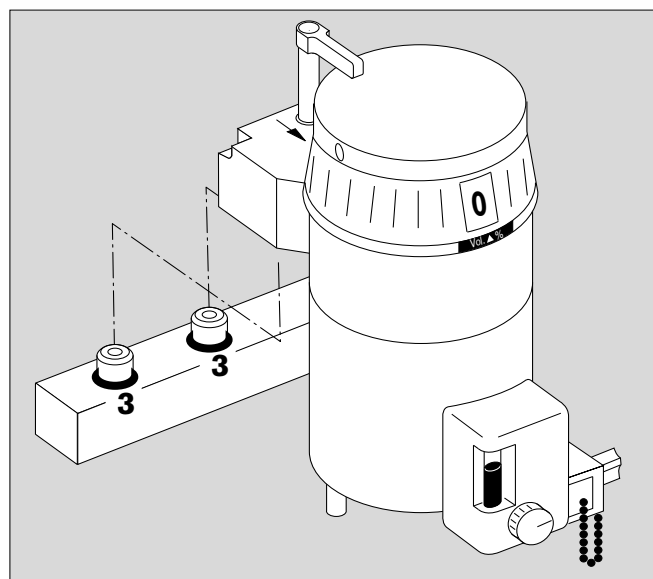

## Filling system

All Vapor 19.n models can be supplied with either a key-indexed filling system or with a filling spout.

Germany, and some other countries, stipulate that a key-indexed filling system be used.

Dräger-Vapor 19.3 with key-indexed filling system conforms to DIN 13 252, ISO 5360 and prEN 1280.

Key-indexed filling system – for filling Vapor with liquid anaesthetic agent and for draining it – consisting of an agent-specific coded filling device on the Vapor and an agent-specific coded filling adaptor.

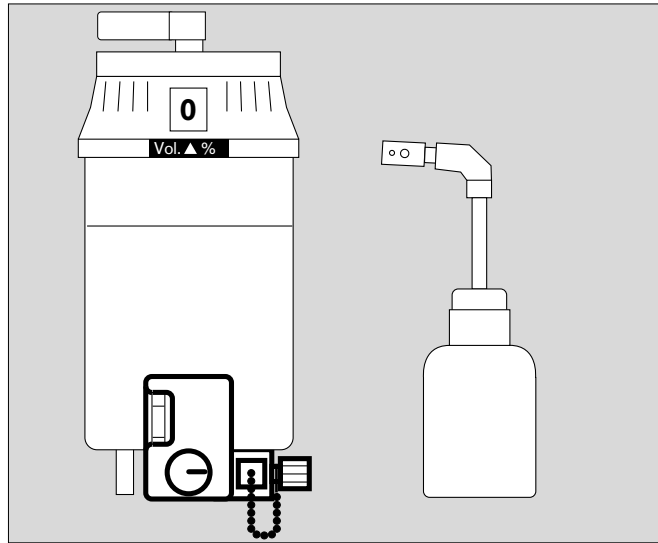

Dräger-Vapor 19.3 with filling spout.

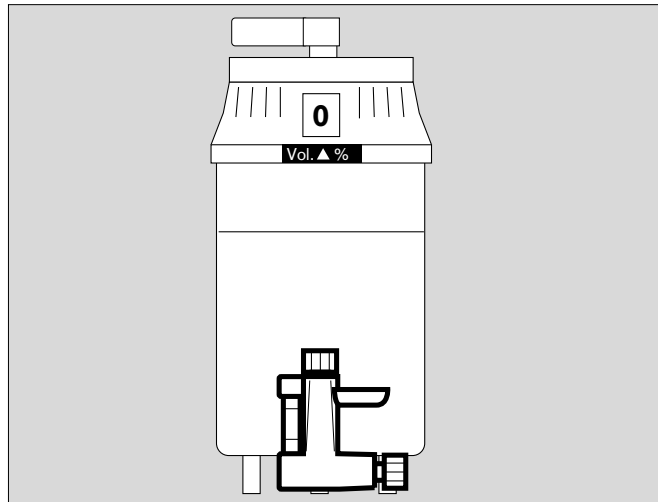

## Interlock system

The interlock system ensures that on anaesthetic inhalation machines with **two** Vapors 19.n\* only one Vapor can be used at any time, and that the other Vapor is blocked.

### Interlock 2

For **two** Vapors 19.3 with plug-in systems.

Illustration: left, Vapor blocked,  
right, Vapor operational.

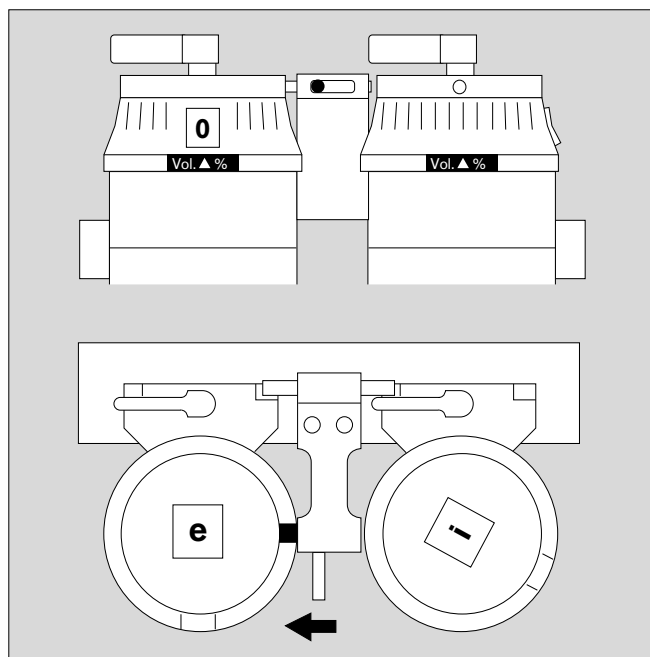

### Interlock 1

For **two** permanently fixed Vapors 19.2.

Illustration: right, Vapor blocked,  
left, Vapor operational.

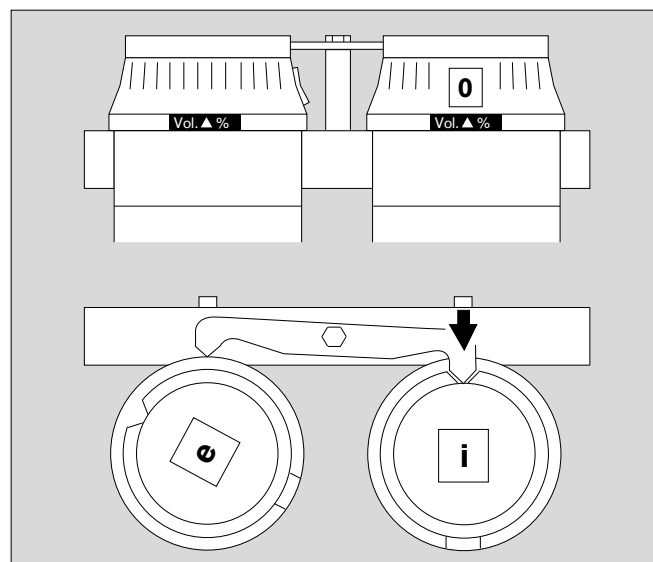

\* **Vapor 19.1** is **not** suitable for Interlock systems 1 or 2.  
However, see "Model Summary", page 42 for connection options.  
Vapor 19.1 can be modified by DrägerService so that it can be  
connected to Interlock 1 or 2.

## Preparation

### Before first operation

The connection systems (e.g. plug-in adaptor and permanent connection of Vapor to anaesthetic machine) must only be installed by trained service personnel.

- Use only authentic Dräger parts for installation.
- 1 Two screws (M 4 x 30) of at least class 8.8 (ISO 4762) strength.  
If screws of different lengths are used – for connecting a piece of different thickness – these must be of at least class 8.8 (ISO 4762) strength.  
Two serrated locking washers, (A 4.3 DIN 6798)
  - 2 Two sealing rings, order no. M 21929
- Tighten screws by applying a torque of 2.7 to 3.0 Nm.

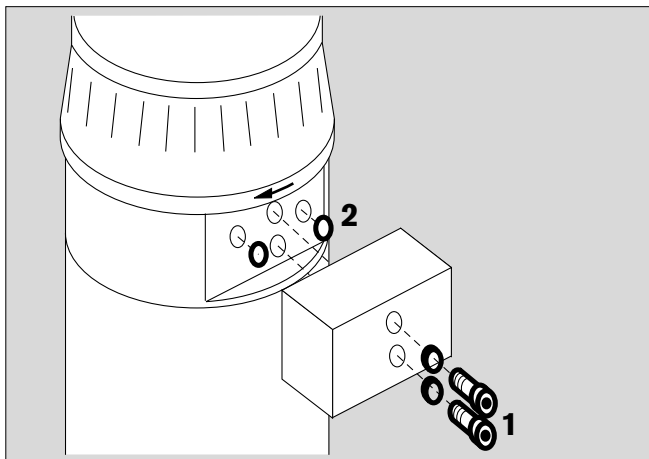

- Check that Vapor is connected correctly so that the fresh gas flows through the vaporiser as shown. If the direction of flow is reversed the concentration delivered will not be correct.

For ISO-cone and conical hose connections:

- Check that the male cone is connected to the Vapor inlet because the flow through the Vapor would be in the wrong direction otherwise.

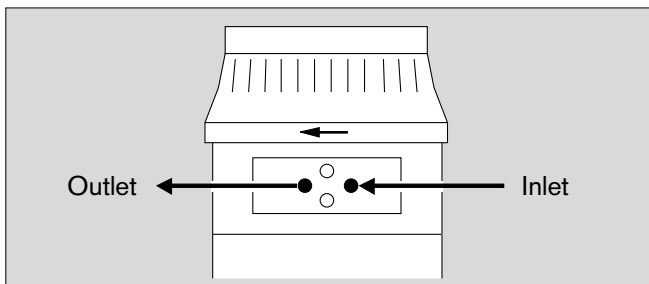

For coded plug-in adaptors:

- Check that the correct plug-in adaptor for the anaesthetic agent concerned has been fitted.  
For a description of plug-in adaptors and their coding, see page 29.  
If plug-in adaptors with wrong codes are used the display on the monitor of the anaesthetic machine will not be correct.

- Check that the Vapor is not damaged.
- Filling Vapor, see page 9.
- Checking concentration, see page 24.

## Filling Vapor

**Anaesthetic agent vapour must not be inhaled – danger to health.**

**Observe information on use and use-by date of anaesthetic agent.**

**Only fill Halothane Vapors with Halothane.**

**Only fill Enflurane Vapors with Enflurane.**

**Only fill Isoflurane Vapors with Isoflurane.**

**Only fill Sevoflurane Vapors with Sevoflurane.**

Note colour-coding of anaesthetic agent bottle and Vapor:

Anaesthetic agent	Letter on handwheel	Colour strip
Halothane	h	red
Enflurane	e	orange
Isoflurane	i	purple
Sevoflurane	s	yellow

**If the wrong agent is used, the concentration delivered may be significantly higher or lower than the one set at the handwheel.**

**A Vapor which has been filled incorrectly must not be used again.**

Call DrägerService to re-instate Vapor.

**Keep Vapor vertical while it is being filled.**

If it is at an angle it can be overfilled. The concentration delivered might then be significantly higher or lower than the one set at the handwheel.

### Use of anaesthetic agent generic products

The same anaesthetic agents from different manufacturers with different trade names which are identical with respect to composition and physical and chemical properties and which have been approved as drugs may, from the **technical point of view**, be metered, individually or as a mixture, in Dräger Vapors 19.n and monitored by Dräger anaesthetic agent monitors.

Information on the physical and chemical properties of anaesthetic agents can be obtained from the manufacturer of anaesthetic agents only.

Dräger Medizintechnik GmbH cannot give informations on the **pharmacologic reaction** of an anaesthetic mixture composed of the same anaesthetic agents produced by different manufacturers.

If, in case of changing from one generic product to an other one, mixtures of different generic products are to be avoided deliberately:

- Empty the Vapor, page 19.
- Set the handwheel at maximum concentration.
- Rinse the Vapor with air and/or O<sub>2</sub> at a flow of 12 L/min for 30 minutes; connect the anaesthetic gas scavenging system; by this, the anaesthetic agent, which has been used before and has remained in the Vapor after emptying, vaporizes.
- Fill the Vapor with the new anaesthetic agent.

### Vapor with key-indexed filling system

- **Keep Vapor vertical.**

- 1 Switch off Vapor = set handwheel to »0« – »0« button engaged.

When filling during operation:

- The fresh gas flow can remain as set.
- After handwheel has been set to »0« **wait for 5 seconds for pressure to equalise.** If the filling system is opened straight away, the liquid anaesthetic agent will bubble out because the vaporising chamber is pressurised when the Vapor is switched on and in operation.

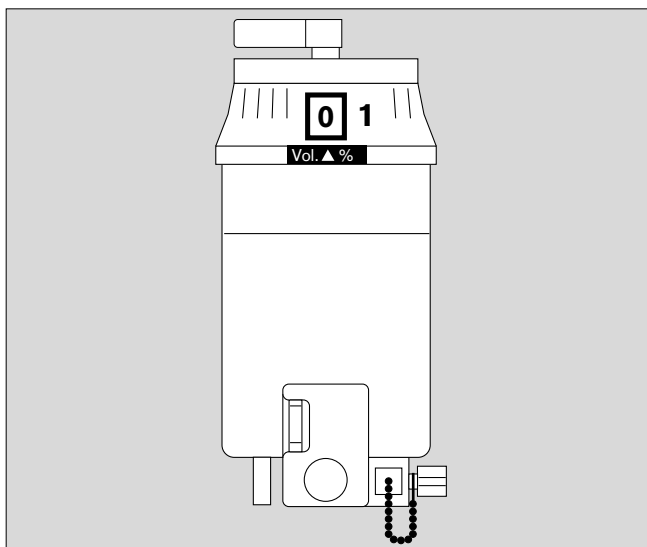

- Use bottle with indexed collar.
- Screw a suitable adaptor firmly onto bottle.

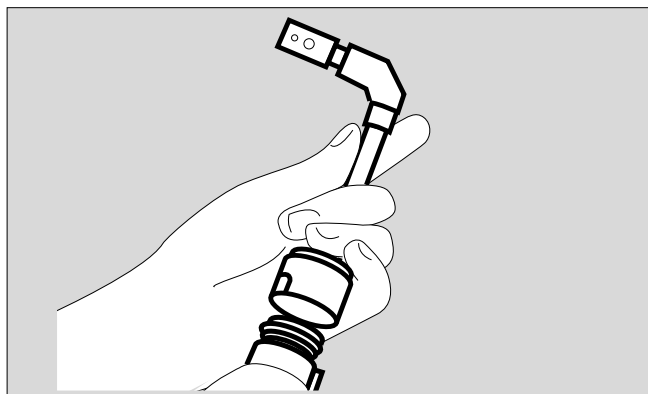

- 2 Turn fill/drain valve to »0« position.
- 3 Undo locking screw **to the stop**, as the seal might otherwise be damaged when the adaptor is inserted.\*
- 4 Pull out sealing block.

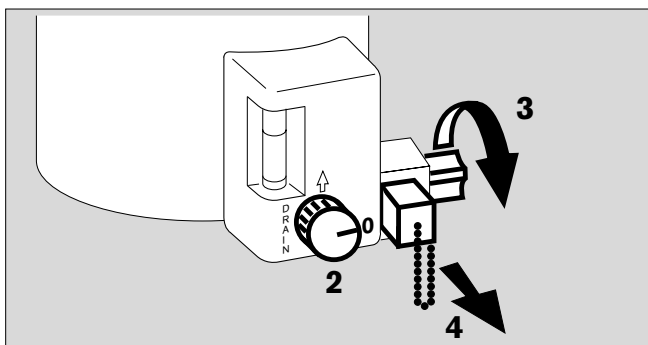

\* The overfill safety mechanism of the key-indexed filling system requires a flexible seal which, however, is sensitive to mechanical stress. Its service life can be extended if the locking screw, when removed, is always unscrewed right to the stop. The seal is a wear part and may only be replaced by duly qualified specialists.

- Hold anaesthetic agent bottle upright.  
The holes on the adaptor must face to the left to the fill/drain valve.

- 1 Push adaptor in to the stop.
- 2 Tighten locking screw.

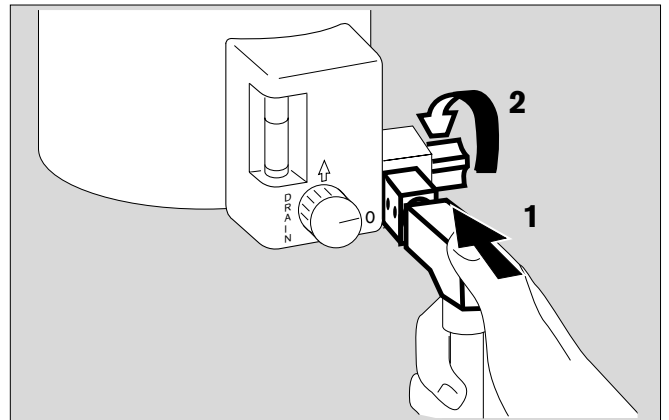

- 3 Swing bottle upside-down **slowly** and hold in this position.  
Wait a moment until the filling adaptor is completely full of liquid anaesthetic agent.

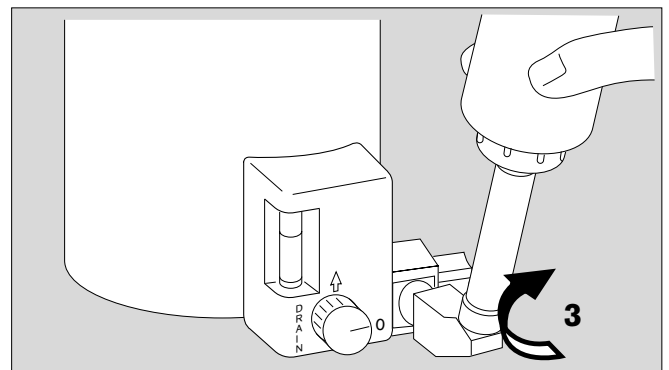

- 4 Turn fill/drain valve to »↑«. During filling, bubbles will rise in the bottle.

If this does not occur:

Swing bottle down and allow anaesthetic agent to flow back.  
Turn fill/drain valve to »0« and repeat filling process from step 3.

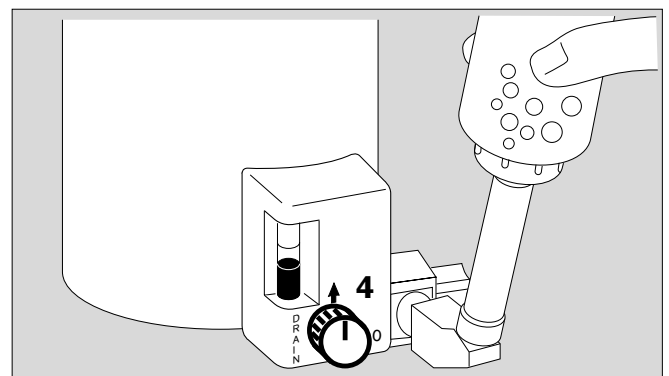

When the maximum mark has been reached:

- 1 Swing bottle down and allow anaesthetic agent to flow back into the bottle from the adaptor.

**Do not fill Vapor above maximum mark.**

A shut-off device prevents filling above the maximum mark. However, if the adaptor is not properly connected to the bottle or the Vapor, or if the handwheel is not set at »0«, the anaesthetic agent may continue to flow into the Vapor.

If Vapor is filled above the maximum mark, the anaesthetic agent can flow to the outside via an overflow drain at the back of the key-indexed filling system.

Then:

- Swing bottle down.
  - Set fill/drain valve to »DRAIN« and drain anaesthetic agent into the bottle until maximum mark is reached.
- 2 Turn fill/drain valve back to »0«.
  - 3 Unscrew locking screw **to the stop**.
  - 4 Pull adaptor out.

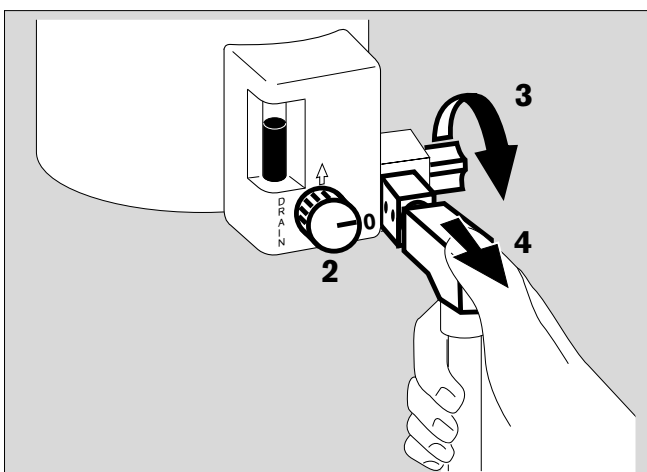
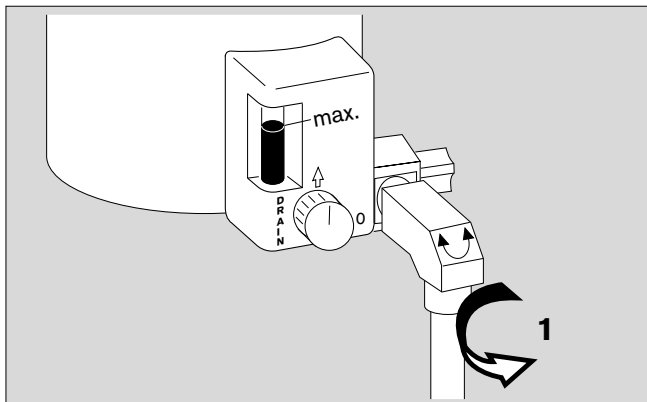

- 5 Push sealing block in **fully**.

**6 Tighten locking screw.**

If this is not done, fresh gas and anaesthetic agent vapour may escape when Vapor is next switched on.

- Close anaesthetic agent bottle.
- Allow any residues of anaesthetic agent in the adaptor to evaporate under an extractor fan.

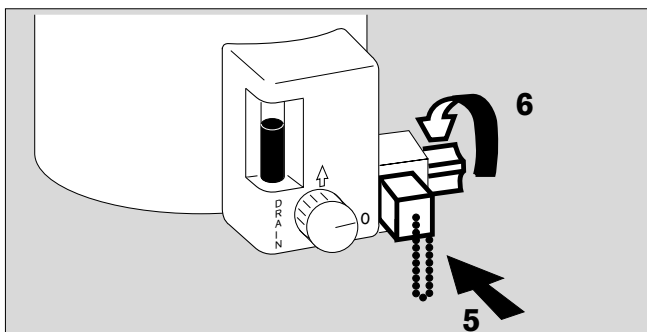

### Vapor with filling spout

- **Keep Vapor vertical.**
  - Clean filling spout with dry cloth.
- 1 Switch off Vapor = turn handwheel to »0«, »0« button engaged.

When filling during operation:

- The fresh gas flow may remain switched on.
- After handwheel has been set to »0«, **wait for 5 seconds for pressure to equalise.**  
If the filling system is opened straight away, the liquid anaesthetic agent will bubble out, because the vaporising chamber is pressurised, when the Vapor is switched on and in operation.

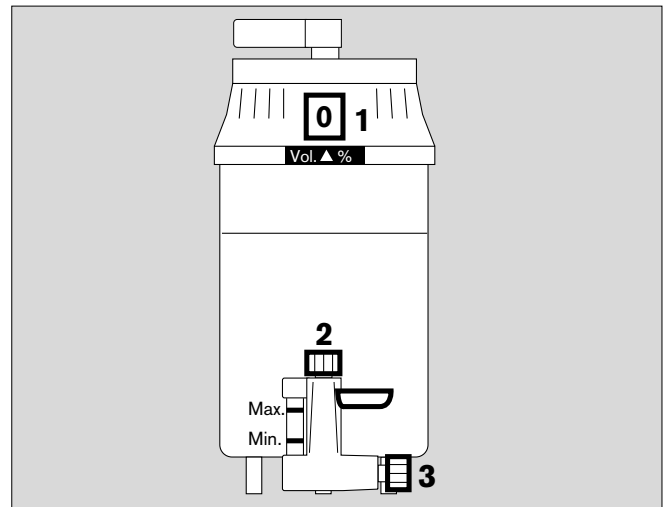

- Use the correct anaesthetic agent bottle.
- 2 Open inlet valve by about 3 turns.
  - 3 Outlet valve must be closed.
- Pour anaesthetic agent into the filling spout – note filling level on sight glass – **fill to maximum mark only.**
  - 2 Close inlet valve completely.
  - Close anaesthetic agent bottle.

If filling has exceeded maximum mark:

- Drain off excess anaesthetic agent, see "Draining Vapor", page 21.

## Connecting Vapor

### Vapor to plug-in system

#### Use Dräger plug-in system only.

- Handwheel to »0«, »0« button engaged.
- 1 There must be undamaged sealing rings on both pins as fresh gas or anaesthetic agent may escape otherwise.
  - 2 Locking lever in position over handwheel.

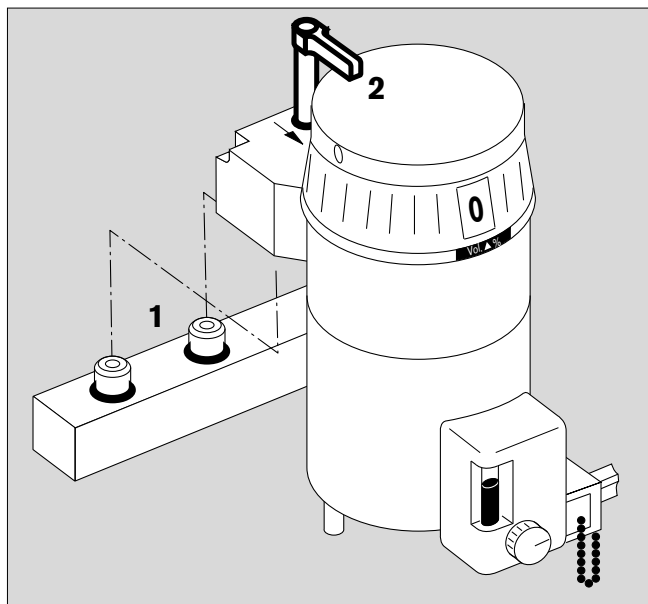

- Anaesthetic ventilators with two plug-in systems and Interlock 2:  
Move the latch on the Interlock 2 to the opposite position before hooking in the Vapor.
- Hold Vapor in vertical position with both hands and lower gently towards the plug-in system. The holes of the plug-in adaptor must fit on the pins on the plug-in system to avoid any damage to the sealing surfaces.

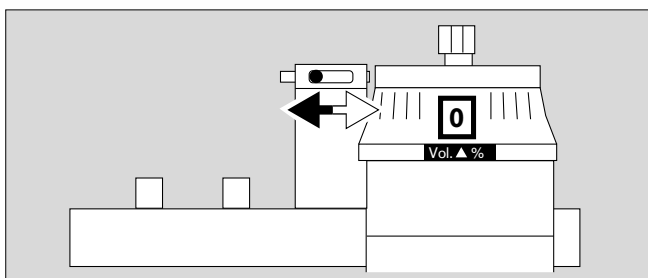

The Vapor must be level and stable on the plug-in system, otherwise a loss of fresh gas, leaks or excessively low output concentrations may result.

If this is not the case:

Disconnect Vapor, as described on page 18, and then re-connect.

- 3 Turn locking lever 90° clockwise, until it engages. The Vapor is then secured and cannot be removed.

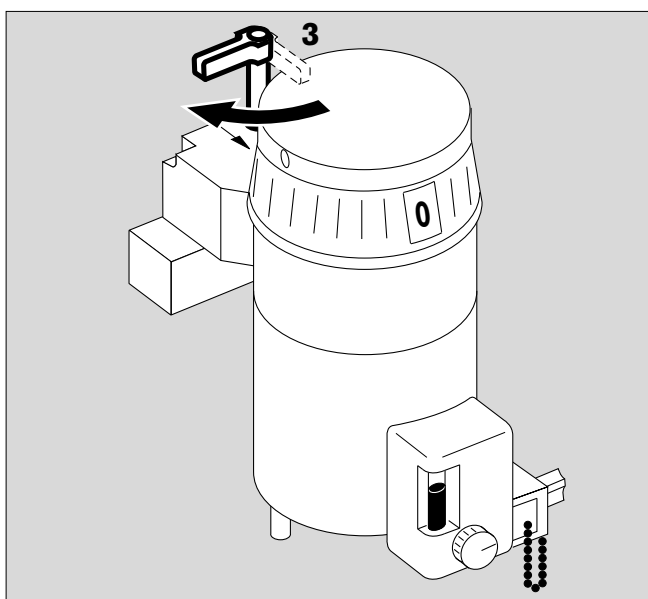

### Vapor without Interlock

If two Vapors are connected in series without an Interlock system or Vapor switch there is a risk that both Vapors will be used at the same time. If this happens, gas containing anaesthetic agent will flow from one Vapor into the vaporising chamber of the other Vapor where the two anaesthetic agents will mix – the mixture of anaesthetic agents cannot be controlled.

 **Make sure that only one Vapor can be used at any one time.**

Dräger recommends that an Interlock system or a Vapor switch is used **without fail** so that there is two-way locking if two Vapors are connected.

When using two Vapors with ISO cones or hose connections:

- **Never connect Vapors in series.**

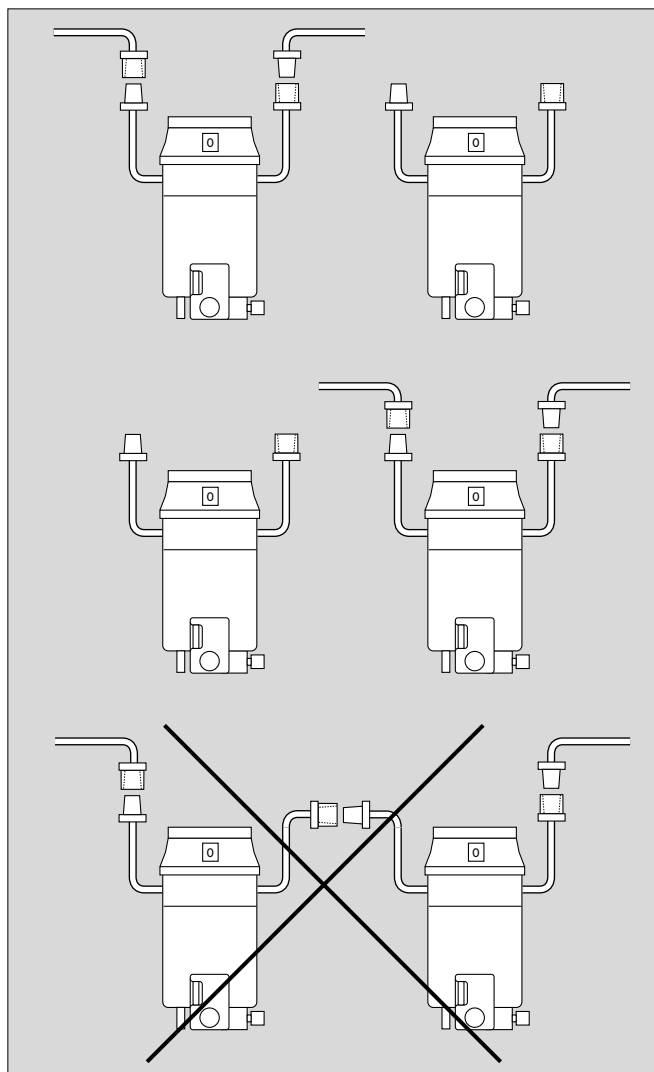

## Operation

### Checks before starting anaesthesia

- Anaesthetic agent monitor is switched on and set to correct anaesthetic agent.\*

During low-flow and minimal-flow operation, the concentration of anaesthetic agent in the fresh gas may be very different from the concentration in the breathing system. It is, therefore, essential to measure the inspiratory and/or expiratory anaesthetic agent concentration.

- O<sub>2</sub> monitor is switched on.
- There is enough anaesthetic agent in Vapor.
- Sealing block on key-indexed safety filling system is in place and locking screw is tightened.
- Filling spout: inlet and outlet valve are closed.
- Handwheel is engaged at »0«.
- Vapor is connected to anaesthetic machine properly and sealed.
- Seals on plug-in system are perfect.
- Vapor plug-in adaptor is in a level position.
- Locking lever turned to left.
- It is only possible to operate one Vapor at a time.
- Anaesthetic machine has been prepared in accordance with the relevant Instructions for Use and scavenging system is connected.

---

\* The maximum adjustable alarm limit on the anaesthetic agent monitor must be greater than Vapor's maximum concentration.

## Setting concentration of anaesthetic agent

Only use Vapor which is in proper working order.

- First set flow of fresh gas on anaesthetic machine, then
- 1 **press** »0« button and
  - 2 turn handwheel anti-clockwise to the concentration of anaesthetic agent desired.
- **Concentrations of less than 0.2 (0.3) vol.% must not be set.**  
Below these values the concentration delivered is not defined.
  - Check filling level in sight-glass regularly and fill the Vapor when minimum mark is reached, at the latest:  
Filling Vapor, see page 9.

When changing to a Vapor for a different anaesthetic agent:

- Switch anaesthetic agent monitor over to the new anaesthetic agent.

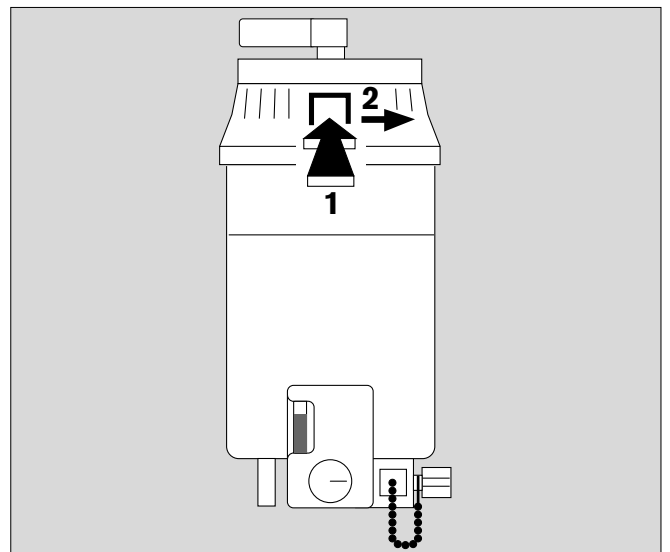

## Use with scanner (MRT, NMR, NMI)

The Vapor can be used during scanning with magnetic fields of up to 70 millitesla.

**However when changing Vapor, do so outside of scanner room.**

**When removing Vapor, do so outside of scanner room.**

The Vapor contains ferro-magnetic parts and will be attracted by the magnetic force of the scanner.

- Vapor may only be used with an anaesthesia machine suitable for NMR tomography, such as Titus NMR.
- Only use monitors which are suitable for use with scanners.

## Use when at an angle

e.g. with emergency equipment

Fixed Vapors may be operated at an angle of up to 45°. Plug-in systems may leak when the device is in a sloping position.

The filling level in the sight-glass will be affected by the sloping position of the device. Place the device in vertical position when checking filling level and filling. If Vapor is accidentally tilted by more than 45°, check concentration being delivered, see Behaviour when tilted, page 39.

## Shut-down

- To switch off Vapor = turn handwheel clockwise to »0« – until it engages.

Then:

- Switch off fresh gas flow on anaesthetic machine.

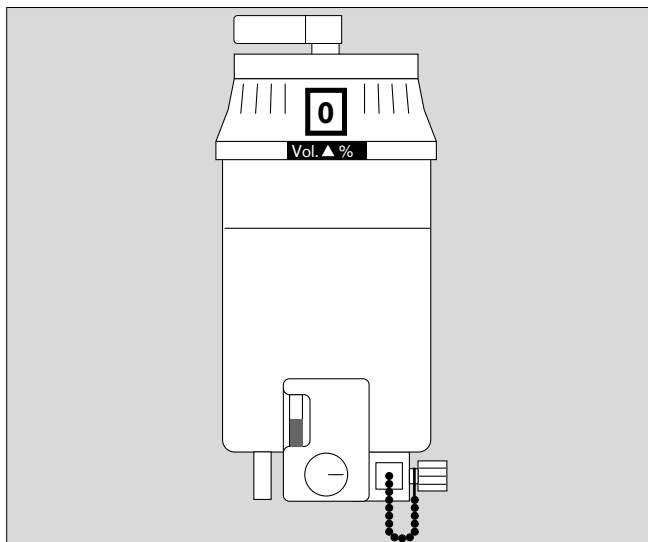

## Disconnecting Vapor from plug-in system

- 1 Switch off Vapor = turn handwheel clockwise to »0« – until it engages.
  - 2 Turn locking lever 90° anti-clockwise to unlock.
- The Vapor can now be carefully lifted off the plug-in system, with both hands.  
The fresh gas will flow to the fresh gas outlet through an internal line in the plug-in system.

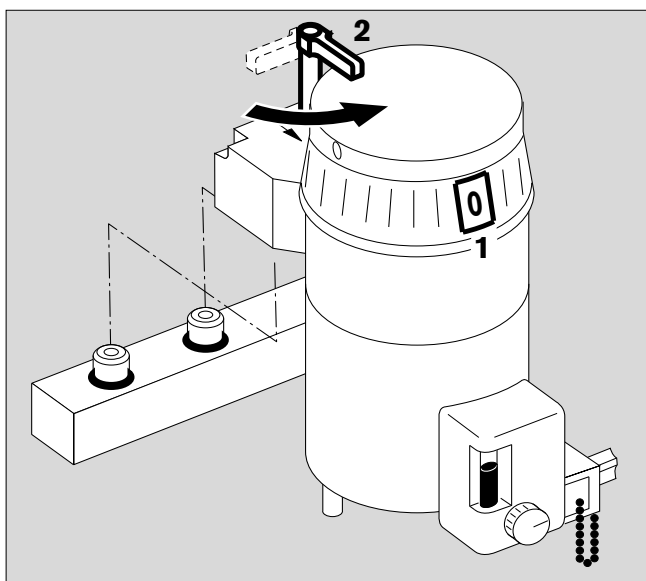

## Draining Vapor

- before it is moved around if there is a risk that it will be tilted by more than 45°,
- when it is not going to be used for more than one month.

**Anaesthetic agent vapours must not be inhaled.**  
Danger to health.

## Vapor with key-indexed filling system

- 1 Switch off Vapor = turn handwheel to »0« – »0« button engaged.

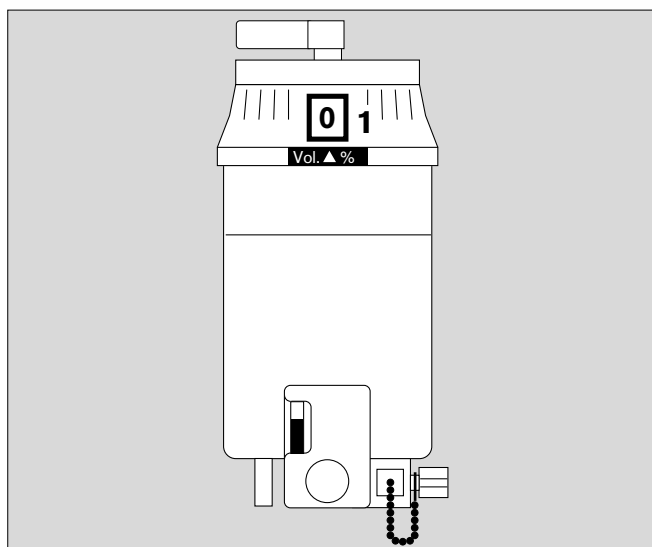

- Use correct bottle of specific anaesthetic agent.
- Screw suitable adaptor firmly onto bottle.

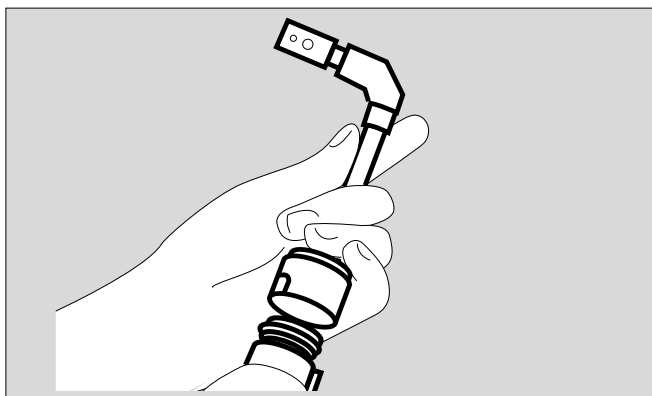

- 1 Switch fill/drain valve to »0«.
- 2 Unscrew locking screw **to the stop**, as the seal may be damaged otherwise when inserting the adaptor.
- 3 Pull out sealing block.

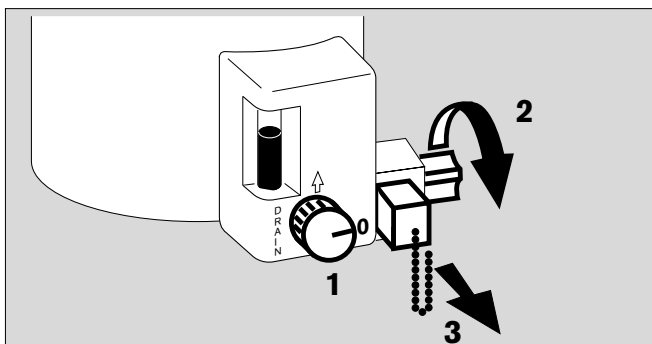

## Operation Draining Vapor

- Hold empty anaesthetic agent bottle upright. The holes on the adaptor must face to the left to the fill/drain valve.

- 1 Push adaptor in to the stop.
- 2 Tighten locking screw.

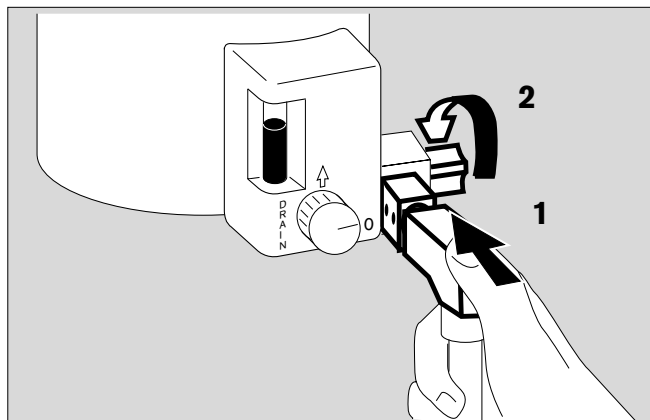

- 3 Turn fill/drain valve to "DRAIN". Anaesthetic agent will flow into bottle. Do not fill bottle to the top. Drain until no more liquid can be seen in the sight-glass. The Vapor is now drained except for anaesthetic agent in the wick.

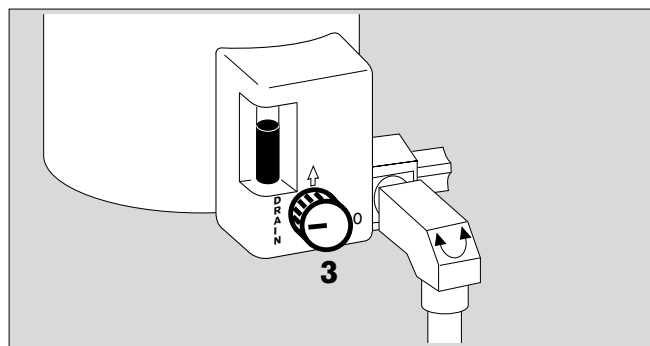

- 4 Turn fill/drain valve back to »0«.
- 5 Unscrew locking screw to the stop.
- 6 Pull adaptor out.

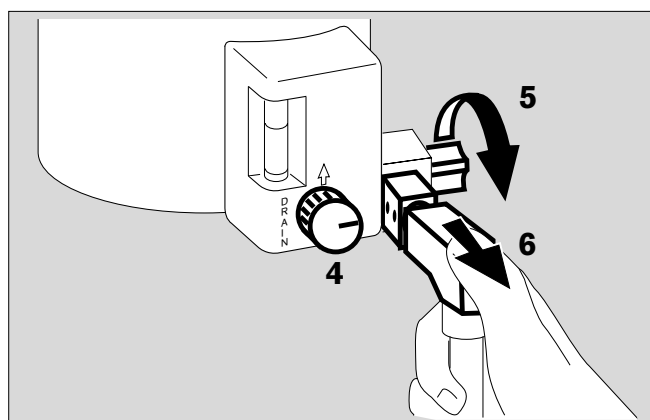

- 7 Insert sealing block fully.
  - 8 Tighten locking screw.
- Allow residue of anaesthetic agent to evaporate under an extractor fan.
  - Close anaesthetic agent bottle.
  - Mark bottle: "Used anaesthetic agent".

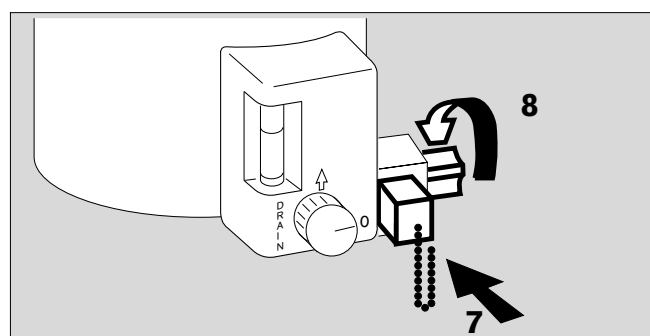

### Vapor with filling spout

- 1 Turn handwheel to »0« – until it engages.
- 2 Hold an empty bottle for the **appropriate anaesthetic agent** under the outlet nozzle of the filling spout.
- 3 Open outlet valve by about three revolutions – do not screw valve out.

When no more anaesthetic agent drains from the outlet nozzle, the Vapor is empty except for the anaesthetic agent remaining in the wick.  
Do not fill bottle right to the top with anaesthetic agent.

Then:

- 3 Close outlet valve again.
- Mark bottle: "Used anaesthetic agent".

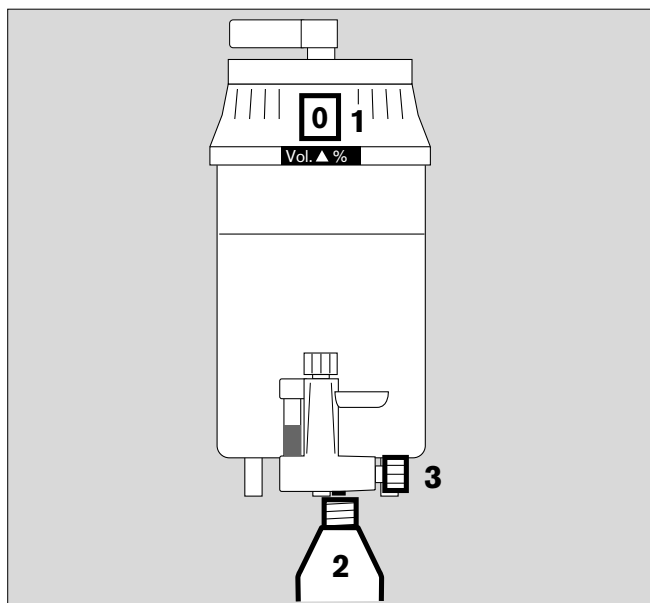

### Storage

See "Technical Data", page 27 for ambient conditions.

- Set handwheel to »0« – »0« button is engaged.
- Drain Vapor, page 19 or 21.
- For storage periods of more than 6 months, blow off anaesthetic agent in wick. To do so: set at 4 vol.% and flush for about 4 hours with 4 L/min Air. Make sure gas flows into the scavenging system.
- Before renewed Readiness for Operation, carry out inspection and service.

## Care

### Cleaning

Wipe heavy stains off Vapor with disposable cloth.

**Do not immerse Vapor in liquid.**

If other liquids get into the vaporising chamber, the patient may be harmed, or corrosive products may be formed, e. g. by ingress of water, and affect the Vapor's performance.

**Do not put filling adaptor in water or disinfectant solution.**

**For Halothane Vapors, observe the following.**

Halothane contains thymol to stabilise it, which is less volatile than Halothane and therefore, accumulates in the Vapor. Thymol and other reaction products may gradually affect the functioning of the wick inside the vaporising chamber and colour the Halothane yellow.

When dirt particles are present in the sight-glass or when the Halothane has turned yellow:

- Drain off discoloured Halothane (see page 19 and 21).
- Re-fill to the maximum mark with fresh Halothane (see page 9), allow to interact for about 6 hours and then drain completely.
- Dispose of drained Halothane in accordance with regulations.

If yellow discolouration persists:

- Have wick replaced by trained service personnel.

## Disinfecting

Use surface disinfectants for disinfection. For reasons of material compatibility use disinfectants based on:

- aldehydes,
- alcohols,
- quaternary ammonium compounds.

Damage to material may occur if preparations are used which are based on:

- halogen-releasing compounds,
- strong organic acids,
- oxygen-releasing compounds.

We recommend that disinfectants on the current DGHM (DGHM: German Society for Hygiene and Microbiology) list are used.

The DGHM list (published by mhp-Verlag GmbH, Wiesbaden, Germany) gives the composition of each disinfectant. For countries where the DGHM list is not familiar, we recommend the types of disinfectants given above.

**Do not immerse Vapor and filling adaptor in liquid and do not sterilize.**

**Do not allow disinfectants and cleaning agents to get into the gas inlet or gas outlet, or the filling system. Wipe off any residues.**

### Wipe disinfecting

- e.g. with Buraton 10 F (Messrs. Schülke & Mayr, Norderstedt, Germany) or Cidex (Messrs. Johnson & Johnson, Norderstedt, Germany).  
Follow manufacturer's instructions.

### Disinfecting in Aseptor disinfecting machine together with the anaesthetic machine.

- Wipe off any dirt with disposable cloth.
- Vapor must be connected to the anaesthetic machine and Vapor can remain filled.
- Turn handwheel to »0« – »0« button engaged.
- Disinfect Vapor on anaesthetic machine in accordance with Aseptor, Instructions for Use.
- Do not use any programme which has temperatures over 35 °C.

## Checking concentration

Concentration measurements to check specified accuracy can only be carried out with highly accurate measuring devices and under precise calibration conditions.

Observe the following test conditions:

- Vapor at least half full.
- Condition the filled Vapor to  $(22 \pm 2)^\circ\text{C}$ . If the Vapor has previously been used or stored at a different temperature wait for a time for the temperature to equalise. This time varies with the temperature difference.

$\Delta T$	up to $\pm 2^\circ$	$6^\circ$	$10^\circ$	$20^\circ$
Hours	1	3	4	5

- Pressure fluctuations less than 5 mbar.
- Set flow of between 2.5 to 4 L/min. Use O<sub>2</sub> if Air is not available. Allow gas to flow into scavenging system.
- Connect tested anaesthetic agent measuring device to Vapor outlet or to fresh gas outlet on anaesthetic machine. Set measuring device as appropriate for anaesthetic agent used. For zero calibration of measuring device, the carrier gas used (Air or O<sub>2</sub>) must be taken into account. The measuring device must be more accurate than  $\pm 0.1$  vol.% and  $\pm 10$  % of measured value.  
Make sure that the concentration is not affected by absorption or leaks in the connecting line.  
Note whether measured values are in % partial pressure or vol.%.

Check at least 3 concentration settings, including 1 and 4 vol.%.

Adjust handwheel, then take concentration reading on measuring device after about 2 minutes.

The concentration delivered as partial pressure must be within the following tolerances:  
 $\pm 15$  % of set value or 0.15 % partial pressure whichever is the greater (for Vapors with a maximum concentration of 4 and 5 vol.%)  
and  
 $\pm 20$  % of set value or 0.20 % partial pressure whichever is the greater (for Vapors with a maximum concentration of 7 and 8 vol.%)  
plus the tolerance of the measuring device used.  
Note that the tolerance of the measuring device may be greater in the lower concentration range.

Also note that, if the test is carried out with O<sub>2</sub>, the tolerances will be shifted in addition to higher concentrations, since O<sub>2</sub> increases the concentration delivered by the Vapor.

Set vol. %	Increase in vol. % delivered when O <sub>2</sub> is used
<1.0	+0.05
1.0 to 2.0	+0.10
2.5 to 3.5	+0.15
4.0 to 6.0	+0.20
6.0 to 8.0	+0.25

Example of test tolerances:

Vapor with 5 vol. % maximum concentration

3 vol. % setting,  
at which 15 % Vapor tolerance = 0.45 vol. %  
and, for example, 5 % measuring device tolerance = 0.15 vol. %.

Total tolerance limits = (3 ±0.6) vol. % = 2.4 to 3.6 vol. %

With O<sub>2</sub> sample gas:

Shifted by +0.15 = 2.55 to 3.75 vol. %

When measuring in volume percentage and at atmospheric pressures which deviate from 1013 hPa, convert to partial pressure: (see also pages 32 and 36).

$$\text{Concentration [\% partial pressure]} = \frac{\text{Measured value [vol. \%] \cdot atmospheric pressure [hPa]}}{1013}$$

Example:

Measured value: 4.5 vol. % and  
atmospheric pressure: 900 hPa

$$\text{Concentration} = \frac{4.5 \cdot 900}{1013} \text{ \% partial pressure} = 4.0 \text{ \% partial pressure}$$

#### After test

- Switch off Vapor = turn to »0« – »0« button engaged.
- Switch off Air and O<sub>2</sub> flow.

Do not use Vapor if the concentration is not within the tolerances given.

Vapor must be checked by trained service personnel.

## Maintenance Intervals

Clean and disinfect Vapor before each maintenance\* – and also when returning for repair.

### Inspection and service

**Every six months**, at the same time as the anaesthetic machine, to be carried out by trained service personnel.

A record must be kept.

Recommendation: Call DrägerService for inspection and service.

### Packing for dispatch

**Drain Vapor completely**, clean and disinfect.

Each Vapor must be packed **individually** with care.

Use original packing, when possible.

If original packing is not available use strong packing, with at least 5 cm bubble-wrap or impact-resistant material.

Fasten package securely.

### Taking back of Vapors

When repair is not economical, DrägerService offer to take back Vapors for proper disposal.

---

\* According to DIN 31 051 the following definitions apply:

Inspection = determining actual condition

Service = measures to maintain required condition

Repair = measures to re-establish required condition

Maintenance = inspection, service and, when necessary, repair

## Technical Data

### Ambient conditions

During operation	
Temperature	15 to 35 °C
Atmospheric pressure	700 to 1100 hPa
Relative humidity	0 to 95 %
Magnetic induction (e.g. with scanners)	<70 Millitesla
During storage (not filled, wick dry)	
Temperature	-20 to 70 °C
Atmospheric pressure	500 to 1200 hPa
Relative humidity	0 to 95 %
Magnetic induction (e.g. with scanners)	<70 Millitesla

### Set values

Calibrated markings on handwheel	
Vapor standard design 4 (5) vol. %	0.2 / 0.4 / 0.6 / 0.8 / 1 / 1.5 / 2 / 2.5 / 3 / 3.5 / 4 / (5) vol. %
Vapor special design 7 (8) vol. %	0.3 / 0.5 / 0.7 / 1 / 1.5 / 2 / 2.5 / 3 / 3.5 / 4 / 5 / 6 / 7 / (8) vol. %

### Accuracy of concentration delivered for single parameter variation

Vapor standard design 4 (5) vol. %	±0.15 vol. % at 1013 hPa or ±15 % of set value, whichever is the greater
Vapor special design 7 (8) vol. %	±0.2 vol. % at 1013 hPa or ±20 % of set value, whichever is the greater
	under the following conditions:
	– variation of Air flow in flow range given at 22 °C and 1013 hPa (measured according to ISO 5358) or
	– variation of temperature in range given at an Air flow of 4 L/min and 1013 hPa or
	– variation of atmospheric pressure in range given at an Air flow of 4 L/min and 22 °C

Fresh gas flow range	250 mL/min to 15 L/min 250 mL/min to 10 L/min for concentrations >5 vol. %
----------------------	---

Quality of gases required	Clean, medically pure mixtures of O <sub>2</sub> and Air, O <sub>2</sub> and N <sub>2</sub> O O <sub>2</sub> and Air: dew point ≤5 °C at 5 bar N <sub>2</sub> O: water content ≤2 mg/L at 5 bar
---------------------------	---

Flow resistance (without connector)	
Vapor setting »0«	<15 mbar at 10 L/min Air, 15 to 35 °C
Vapor switched on	<60 mbar at 10 L/min Air, 22 °C <110 mbar at 10 L/min Air or O <sub>2</sub> , 15 to 35 °C

## Technical Data

Filling volume for anaesthetic agent

about 200 mL with dry wick  
 about 140 mL with moist wick  
 about 135 mL between minimum and maximum mark

Consumption of anaesthetic agent [mL/hour]

~3 x fresh gas flow [L/min] x concentration [vol. %]

Rough formula for running time [hours] =  
 (for 150 mL anaesthetic agent)

$$\frac{50}{\text{fresh gas flow [L/min]} \cdot \text{concentration [vol. \%]}}$$

Example: fresh gas flow = 2 L/min, concentration = 1.5 vol. %  
 Running time = 16.5 hours

Pressure range

-100 mbar to 200 mbar

Loss of anaesthetic agent when  
 switched off

<0.25 mL liquid/24 hours

Maximum angle of tilt, filled

45° (with fixed connection on anaesthetic machine)

Weight, filled

6.5 kg to 8.5 kg depending on design

Dimensions Vapor 19.n  
 with key-indexed filling  
 system (measured in mm)

Measurements in brackets apply to  
 Vapor 19.n with filling spout

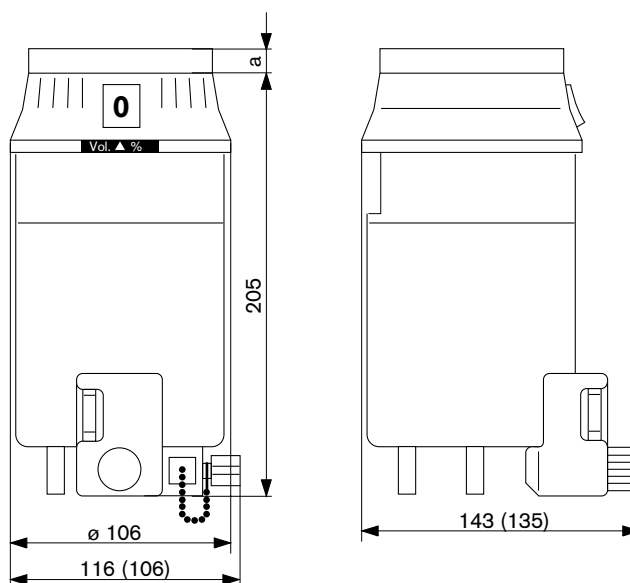

Vapor 19.3: a = 12 mm  
 Vapor 19.2: a = 8 mm  
 Vapor 19.1: a = not available

Vapor conforms to relevant Standards

DIN 13252\*  
 ISO 5358  
 BS 4272  
 SN 057600  
 CSA Z168.3\*  
 ASTM F1161  
 prEN 740 (draft)\*

Key-indexed filling system

ISO 5360  
 prEN 1280  
 CSA Z168.4

\* Standards marked demand a key-indexed filling system

Coding of plug-in adaptors

The display on some Dräger anaesthetic machines indicates whether the Vapor fitted is a Halothane, Enflurane, Isoflurane or Sevoflurane Vapor. The anaesthetic-agent-specific coding on the back of the plug-in adaptor on the Vapor will be read by a sensor in the anaesthetic machine and displayed on the monitor.

**Faulty assembly (using the wrong anaesthetic-agent-specific plug-in adaptors) will result in a faulty display.**

As the coding does **not** analyse the anaesthetic agent delivered by the Vapor, it cannot guarantee that the display is correct when the Vapor has not been correctly filled.

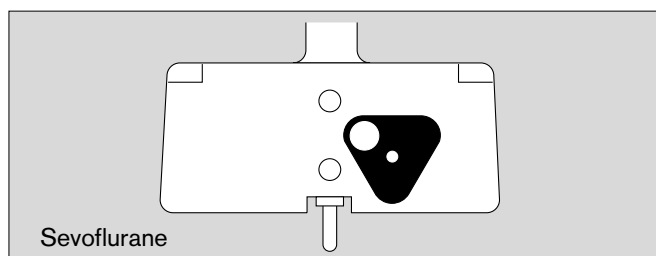
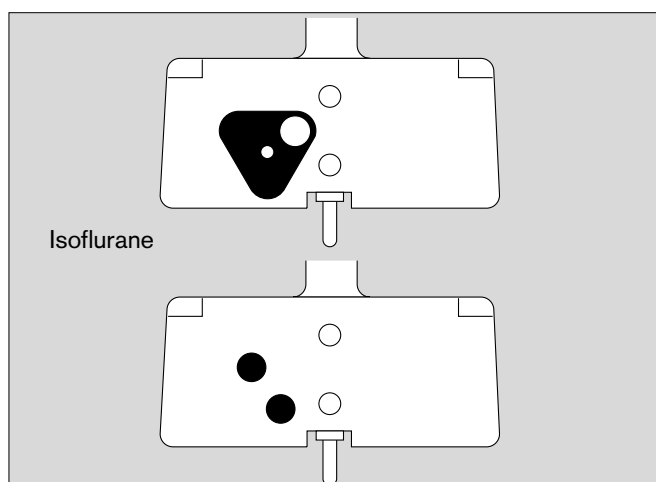
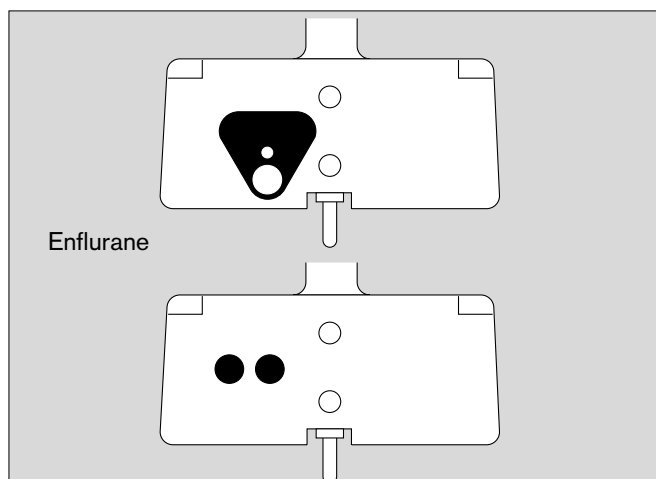
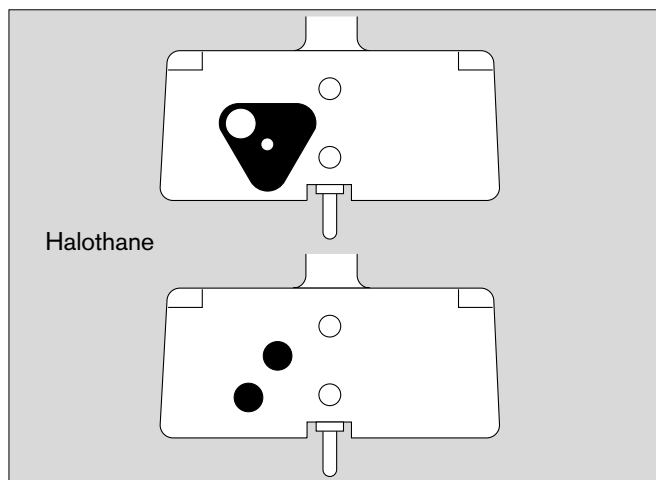

## What's What

### Front View

- 1 Handwheel
- 2 Button for zero point locking
- 3 Colour-coding
- 4 Filling level indicator
- 5 Key-indexed filling system

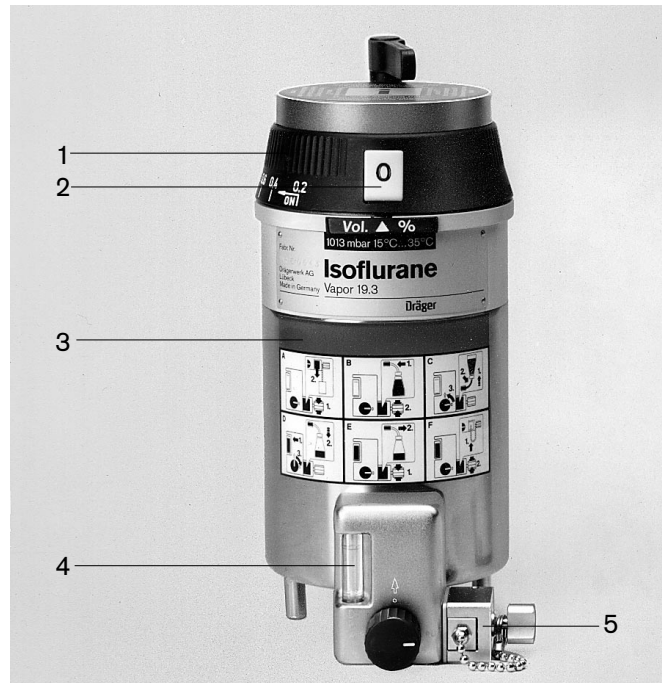

2-1109-83

### Rear view

- 6 Locking lever for plug-in system
- 7 Opening for Interlock locking
- 8 Coding for plug-in adaptor

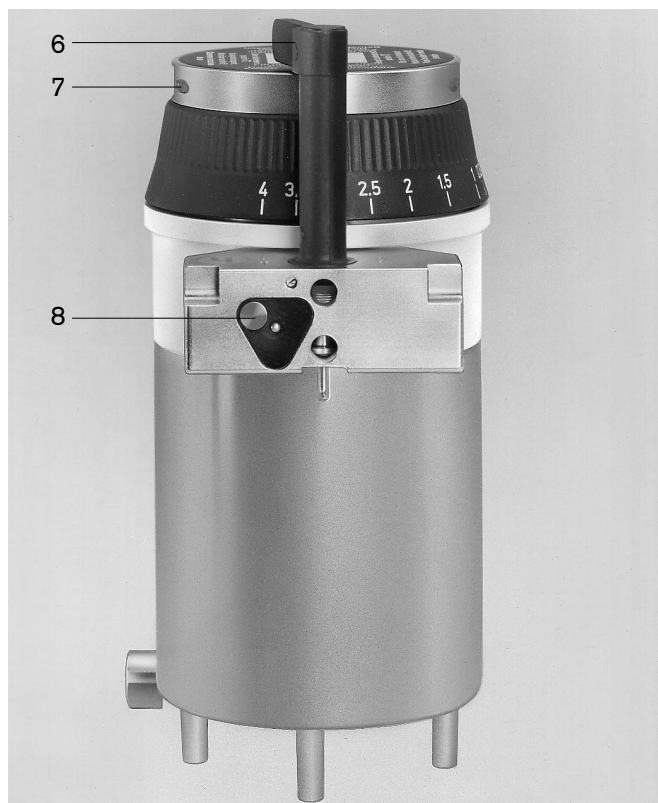

1-149-94

## Description

### Operating principle

In the off position, the handwheel **1** engages at the »0« setting. fresh gas flows from the Vapor inlet **2** through the ON/OFF switch **3** directly to the Vapor outlet **4**.

Vapor's vaporising chamber is then completely shut off from the gas flow and its inlet and outlet are short-circuited.

A small bleed hole connects the vaporising chamber to the atmosphere to prevent any build-up of pressure from the vapour pressure of the anaesthetic agent. It also guards against any anaesthetic agent getting into the fresh gas flow via possible leakage points without being noticed. During anaesthesia the Vapor can only be filled in this unpressurised condition.

When the concentration is set, the fresh gas flows into the vaporising chamber via the ON/OFF switch **3** connected to the handwheel **1**.

Depending on the setting on flow control cone **5**, saturated vapour is added to the fresh gas and some of the fresh gas flows into the vaporising chamber **6** and becomes saturated with anaesthetic agent. The remaining fresh gas is routed past the vaporising chamber **6** through a bypass **7**. The two flows are mixed and routed to the Vapor outlet **4**. The desired concentration results from the proportioning of the two gas streams.

The proportioning of the two gas streams is also influenced by the temperature compensator **8**, which makes use of the thermal expansion characteristics of two different materials to expand or contract the bypass **7**, depending on the temperature. This process compensates for the effect of temperature on the saturation concentration of the anaesthetic agent.

The pressure compensation labyrinth **9** effectively reduces any pumping effect, see page 37 (influence in fluctuations in pressure).

To provide protection against excessive pressure, as, for instance, from a kinked fresh gas hose, the Vapor has a pressure relief valve in the ON/OFF switch **3** which releases fresh gas into the atmosphere in case of high pressures.

When the Vapor commences operation after a break of more than 2 hours, the concentration delivered will be higher than the set value for several seconds, but it will then quickly drop back to the value desired. This effect is the result of anaesthetic vapour diffusing into cavities in the Vapor and then being flushed out when the Vapor is switched on.

This briefly-increased concentration spreads into the hoses and breathing system and, since it is thus dispersed in a large volume, no significant increase in anaesthetic agent concentration will reach the patient.

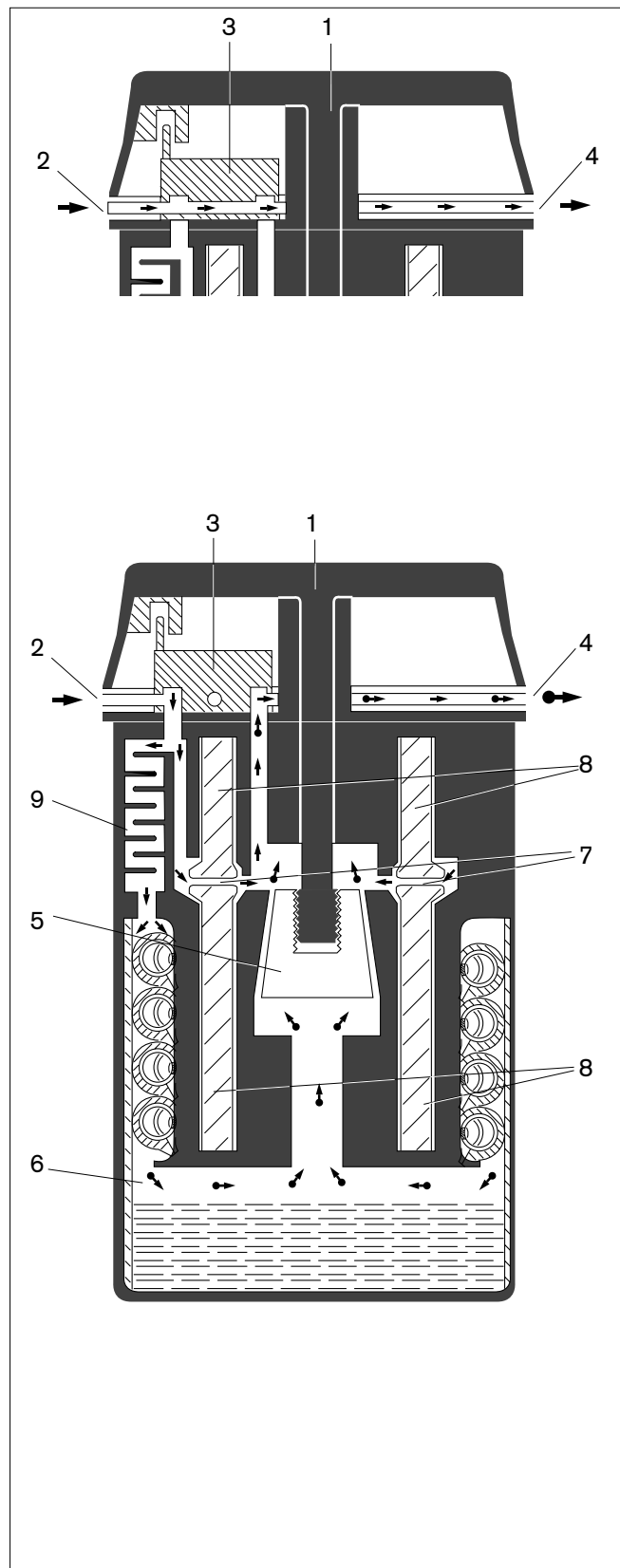

## Calibration

Dräger Vapors are calibrated individually with interference refractometers at 22 °C and at 30 °C with a flow of 2.5 L/min of Air.

Calibration is in % partial pressure (% of 1013 hPa), as is appropriate for most vaporisers which use surface evaporation. The depth of anaesthesia depends on the patient's uptake which is itself determined by partial pressure.

Concentration delivered in % partial pressure at normal pressure of 1013 hPa is identical numerically with the output given in volume percent, so that the specification on the Vapor is given in units of "vol.% at 1013 mbar". The output in vol.% must be corrected for other atmospheric pressure values (see Influence of atmospheric pressure, page 36), but partial pressure and mg/L are absolute values. Output given in % partial pressure is proportional to the quantity of anaesthetic agent delivered in mg per litre of fresh gas. Data output in units of mg/L is unusual, because this varies for different anaesthetic agents at identical partial pressures due to differences in molecular weights.

Some measuring devices used for monitoring concentration are designed to measure in % partial pressure, and others in vol.%. When monitoring the concentration delivered by Vapor it is essential to have information about the units of measure of the monitor and whether conversion of the results to % partial pressure is required.

For simplicity, in these Instructions for Use settings are given in the abbreviated form of vol.%, which means vol.% at 1013 hPa and % partial pressure, respectively.

## Influence of temperature

Vapor compensates for changes in temperature through the different thermal expansion characteristics of two different materials. The saturation concentration of the anaesthetic agent, which rises as temperature rises, is automatically balanced by routing a higher proportion of the gas flow through the vaporising chamber-bypass. This proportion is increased as temperature rises because the material which makes the gap has a lower thermal expansion than the material which surrounds it.

Temperature compensation changes the gap in a linear manner. This compensation does not exactly match the non-linear variation of the saturation concentration for the whole temperature range, so that the concentration delivered still remains slightly dependent on temperature. The deviations are within the accuracy specified between 15 ° and 35 °C. The diagrams show typical dependence. The deviations increase for temperatures outside this range, despite continuing compensation.

Under no circumstances must the temperature of the anaesthetic agent reach boiling point, as the concentration delivered will then become impossible to control. As altitude increases, boiling point falls:

Atmospheric pressure/ Altitude	Boiling point of anaesthetic agent °C			
	1013 hPa 0 m	900 hPa 1000 m	800 hPa 2000 m	700 hPa 3000 m
Halothane	50.2	46.8	43.4	39.8
Enflurane	56.5	53.4	50.3	46.8
Isoflurane	48.5	45.4	42.2	38.9
Sevoflurane	58.6	53.4	52.1	48.7

The operating range of Vapor with Dräger anaesthetic machines has been set in such a way that, in the most critical situation of 700 hPa, 35 °C and a maximum negative pressure of -100 mbar on the Vapor, the boiling point of the anaesthetic agent cannot be reached.

Temperature compensation is resistant to ageing and hysteresis, but is affected by a certain inertia: differences in temperature between Vapor and the room within the 15 to 35 °C range are compensated within the concentration accuracy specified.

However, if the temperature of the Vapor before use was outside 15 to 35 °C, a time of 15 min/°C has to be allowed for temperature adjustment if the concentration is to remain within the accuracy specified.

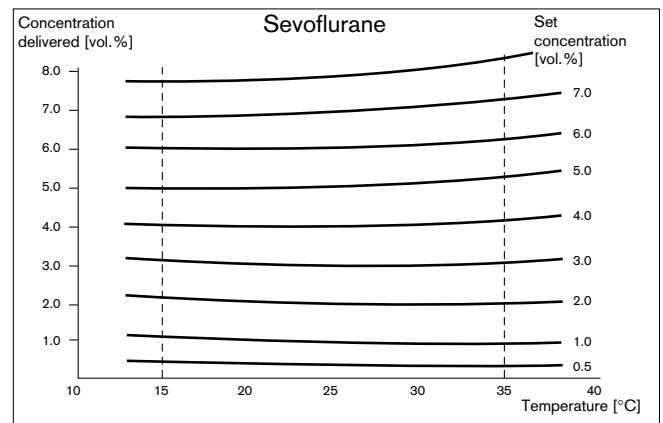
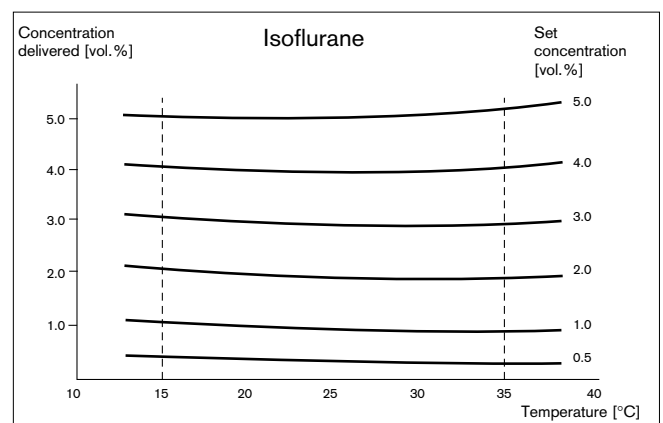
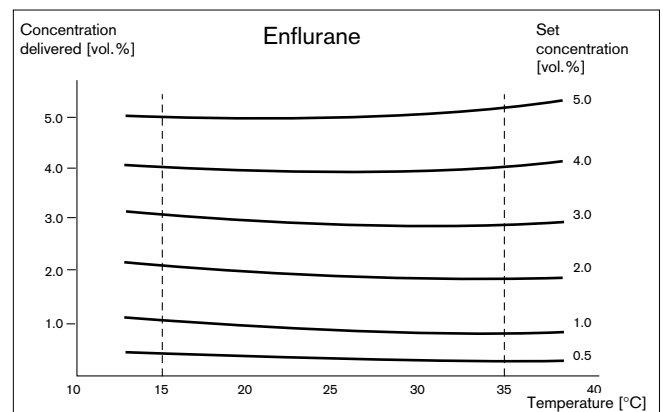
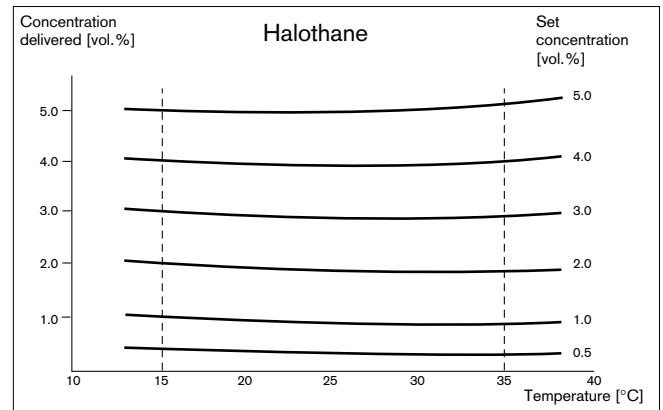

**Influence of flow**

The concentration delivered by Vapor is virtually independent of fresh gas flow within the specified flow range.

The concentration delivered is reduced slightly when high concentrations are set at the same time as a high fresh gas flow. Under such conditions full compensation is not made for the cooling of the anaesthetic agent due to evaporation. However, the concentration delivered will remain within the concentration accuracy specified.

The diagrams show typical dependence of the concentration delivered after 1 minute at 22 °C, 1013 hPa, during operation with Air (measured in accordance with ISO 5358).

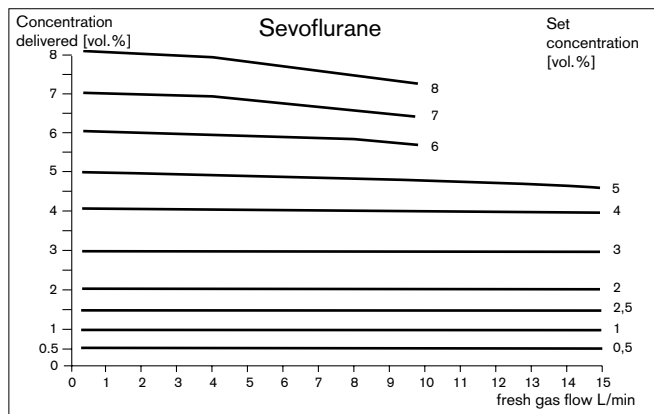
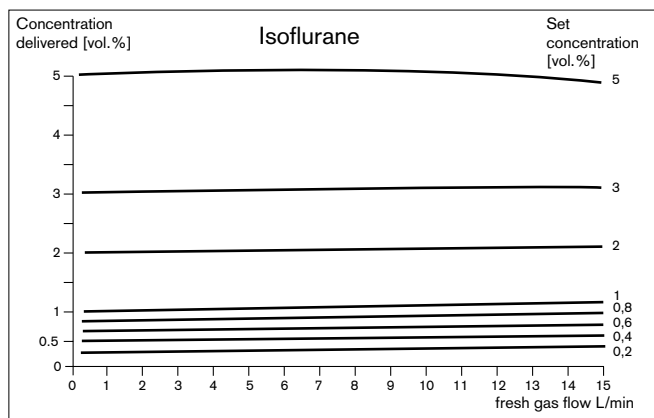
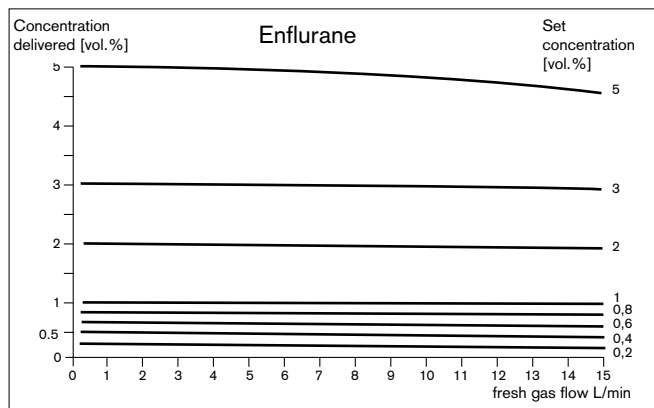
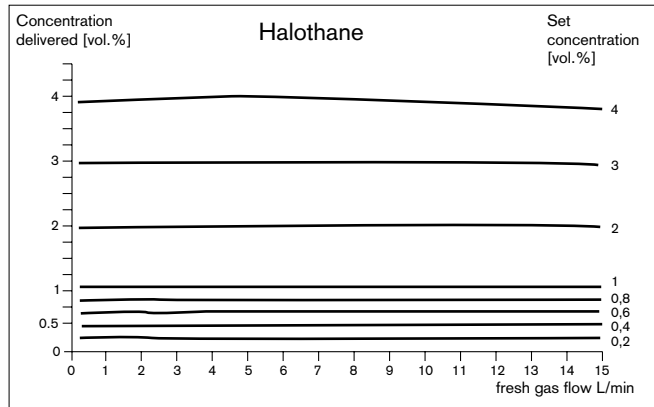

## Influence of gas composition

The concentration delivered is dependent on the composition of the fresh gas since the viscosity and density of the gas changes from one gas and composition to another. The Vapor is calibrated with Air because the concentration delivered is then in the middle of the range for available anaesthetic gas mixtures.

When 100 % O<sub>2</sub> is used the concentration delivered compared with Air rises by 15 % of the set value at most, up to a maximum of 0.3 vol. %

When 30 % O<sub>2</sub> and 70 % N<sub>2</sub>O is used, it falls by 15 % of the set value at most, and by not more than 0.3 vol. %.

The effect of gas composition varies slightly for different anaesthetic agents and, for this reason, maximum effects are given here.

When changing from one gas mixture to another, an additional dynamic effect can occur which may result in a further deviation in concentration until the earlier fresh gas is flushed out of the vaporising chamber.

These deviations and their duration are all the greater,  
 – the lower the volume of anaesthetic agent in the Vapor  
 – the higher the concentration set and  
 – the more extreme the change of gas type.

The extent of this dynamic deviation increases as gas flow increases, though the duration of the deviation decreases.

The diagram shows the dependence of concentration delivered on the fresh gas composition at a 1 vol. % setting. Illustration of maximum measured deviations in the entire 0.25 to 15 L/min flow range at 1 vol. % (22 °C, atmospheric pressure 1013 hPa, Vapor 1/4 filled).

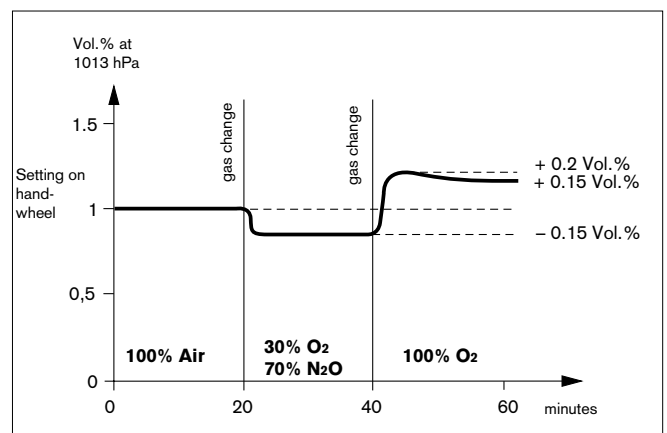

## **Influence of atmospheric pressure**

The anaesthetic agent partial pressure delivered by Vapor (see calibration, page 32) is almost independent of atmospheric pressure, so that weather-based fluctuations do not need to be taken into account and altitude-based pressure changes in the range 700 to 1100 hPa will lead to only small deviations within the accuracy specified. For this reason, the physiological effect – the depth of anaesthesia – at a defined Vapor setting is independent of atmospheric pressure.

When measuring the concentration delivered by Vapor in partial pressure (e.g. with Dräger IRIS or PM 8030/35) there is no influence of ambient pressure.

When measuring in volume percent (e.g. with Dräger PM 8020 or PM 8050) the measured values do, however, change with atmospheric pressure and measured values rise, when atmospheric pressure falls below 1013 hPa.

The following formula for conversion applies:

$$\text{Concentration} \quad = \frac{\text{Measured value [vol.\%]} \cdot \text{atmospheric pressure [hPa]}}{1013 \text{ hPa}}$$

[% partial pressure]

Example:

A concentration output of 4 % partial pressure, when measured in units of vol.% at an altitude of 1000 m (900 hPa) is 4.5 vol.% , and at 2000 m (795 hPa) it is 5.1 vol.%.

Under no circumstances must Vapor 19.n be used at atmospheric pressures and temperatures at which the anaesthetic agent could start to boil (see "Influence of temperature", page 33), as the concentration delivered rises and is impossible to control.

### **Influence of fluctuations in pressure during ventilation**

When ventilation is being carried out without fresh gas de-coupling, pressure fluctuations on the anaesthetic vaporiser can cause a higher concentration to be delivered than is shown on the handwheel setting.

The vapour in the vaporising chamber is compressed when pressure raises, and it expands when pressure falls. When this effect is strong enough it will pump small quantities of saturated vapour backwards through the inlet of the vaporising chamber into the fresh gas.

This pumping effect becomes greater,

- the higher the ventilation pressure and ventilation frequency,
- the more rapid the fall in pressure during expiration,
- the lower the fresh gas flow,
- the lower the concentration set,
- the smaller the quantity of anaesthetic agent in the vaporiser.

The ability of the Vapor to compensate for these effects will reduce them in practise so that the requirements of DIN 13252 and other Standards can easily be met.

When anaesthetic ventilators are being used, which provide a continuous supply of fresh gas to the breathing system (without a buffer for fresh gas de-coupling), and ventilation pressures are greater than 20 mbar and concentration set at <1 vol.% and/or a fresh gas flow at <1 L/min, the Vapor should be filled completely, so that deviations due to fluctuations in pressure can be kept as low as possible.

### **Influence of positive/negative pressure relative to ambient and dynamic pressure**

Vapor's application range is limited to between –100 and 200 hPa relative to the ambient atmospheric pressure at the Vapor outlet.

Pressure in the Vapor is a little higher than ambient atmospheric pressure, as the fresh gas flow builds up dynamic pressures of between 0.5 and 150 mbar in the flow control system.

When O<sub>2</sub> flushing is activated on Dräger anaesthetic machines a negative pressure is produced at the Vapor outlet which may be up to 100 mbar, according to ISO 5358. 100 mbar negative pressure has the same effect as an increased altitude of 1000 m or a drop in boiling point of about 3.5 °C (see "Influence of temperature", page 33).

## Influence of running time

Evaporation of the anaesthetic agent during operation cools the Vapor. The temperature falls more rapidly the higher the concentration set and the higher the flow selected. Saturation concentration decreases as the temperature falls and so the concentration delivered also decreases.

Temperature compensation counters this and limits deviations in the concentration delivered. However, since the temperature at the evaporation point differs a little from the temperature of the temperature compensation mechanism depending on evaporation rate, the duration of operation has some effect on concentration. Since ambient heat is more effectively absorbed as a Vapor cools, a Vapor stabilises at a lower temperature and a slightly lower concentration after a certain time of operation.

All Vapors 19.n conform to DIN 13252, which stipulates that after 20 minutes, and at 8 L/min and 22 °C, no concentration may deviate from the set value by more than  $\pm 20\%$  or  $\pm 0.2$  vol. %.

The diagrams show typical concentration curves, taken at 22 °C and 4 L/min Air.

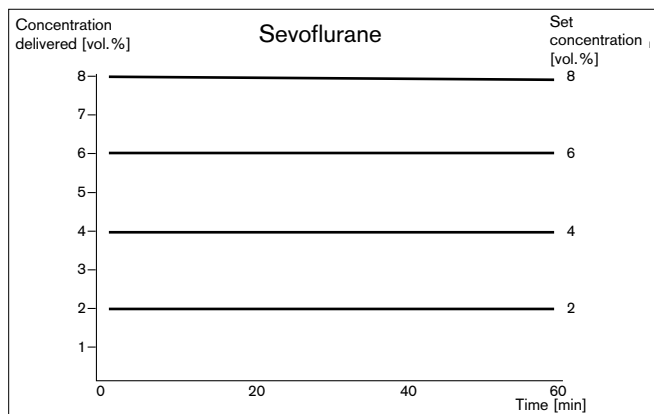
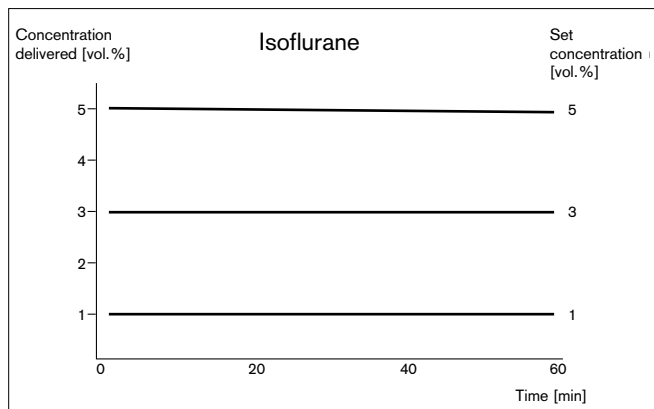
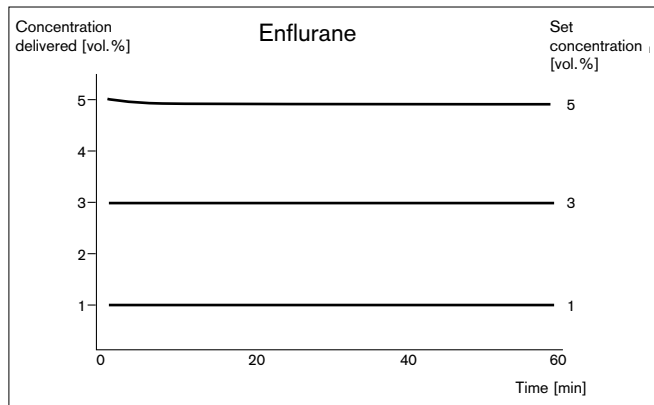
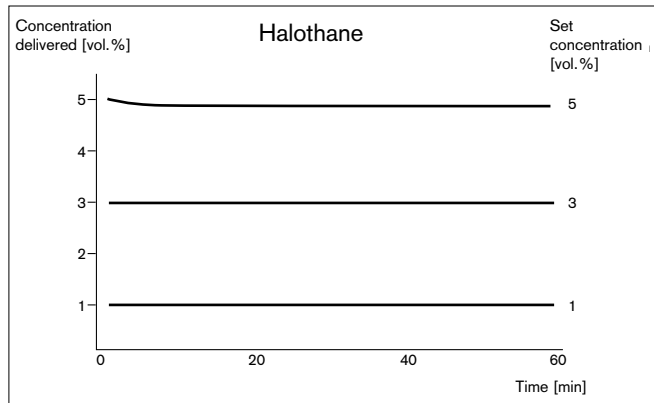

## Behaviour when tilted

A fixed screwed Vapor can be used at an angle of up to 45°.

For a Vapor with plug-in adaptor or on portable anaesthetic machines, there may be occasions when a filled Vapor is tilted by more than 45°. Liquid anaesthetic agent could then get into the flow control system and lead to an incorrect concentration output. If a filled Vapor has been tilted by more than 45°, the concentration being delivered must be checked before it is ready for operation (see "Checking concentration", page 24).

If the concentration delivered is not within the tolerance range specified during this test, drain Vapor and flush with 10 L/min at maximum concentration setting for about 5 to 20 minutes (depending on how long the Vapor has been tilted). Allow gas to flow into the scavenging system. Then check concentration again. Flushing will cool the Vapor markedly so wait for a further 2 to 3 hours before checking the concentration delivered.

If the specified accuracy for concentration is not reached after the Vapor has been flushed a second time, the Vapor must not be used.

Vapor must be checked by DrägerService.

For transportation where the angle of inclination may be greater than 45°, drain the anaesthetic agent (see page 19 and 21).

## Mechanical stress

The Dräger-Vapor is a precise instrument – it must be handled with care and no force applied.

Vapor 19.n has been vibration-tested in fixed configuration for aeronautical conditions (MIL-STD 810 method 514, curve M) and has been passed for **transport** in helicopters.

Because of the vibration, Vapor must not be **operated** in helicopters unless it has vibration-free suspension.

After 10,000 full revolutions of the handwheel, wear is so minimal that the deviation in concentration due to wear is within the accuracy specified.

## Key-indexed filling system

The key-indexed filling system consists of an anaesthetic-agent-specific filling device on the Vapor and an anaesthetic-agent-specific filling adaptor for connection to an anaesthetic agent bottle with an indexed collar.

This system

- prevents filling with incorrect anaesthetic agent
- reduces the amount of anaesthetic vapour released during filling
- prevents any overfilling of Vapor.

The key-indexed filling device has three holes: for filling, venting and draining the Vapor and for overflow. The rotary fill/drain valve switches the function of hole 2.

Filling:

The filling adaptor covers holes 1 and 2. After the bottle has been swung into the upside down position, the filling hose has to fill with anaesthetic agent first. After switching to "↑" the anaesthetic agent flows into the Vapor via hole 1. At the same time, the saturated vapour displaced by the inflowing anaesthetic agent is routed out of the Vapor via hole 2 and the inner tube into the bottle.

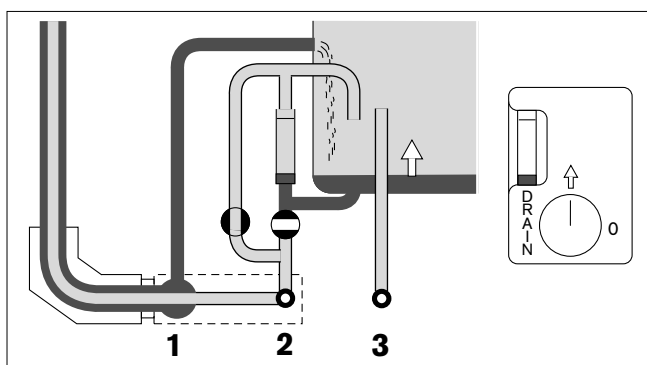

Overflow safety mechanism:

When the filling level reaches the bleed hole and covers it, the supply ceases as gas can no longer be exchanged between Vapor and bottle.

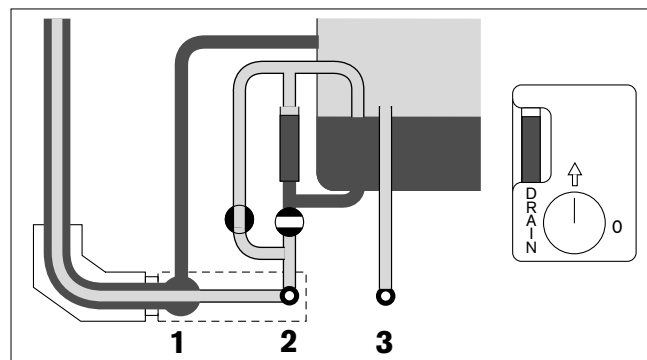

If the bottle and filling adaptor are incorrectly connected to the bottle thread or the seal on the filling system is not tight, the overfilling safety mechanism will no longer function. An overflow 3 is provided so that the anaesthetic agent may overflow to the outside if overfilling continues.

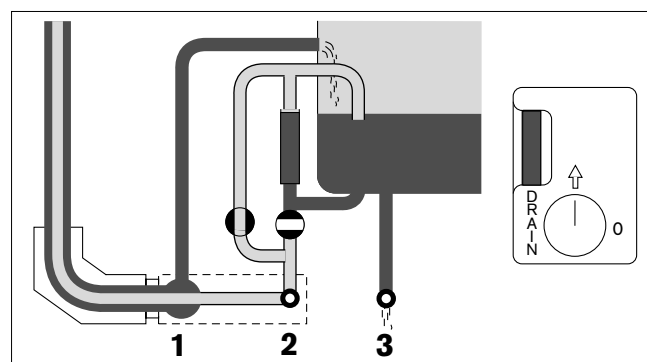

**Draining:**

With the switch at "DRAIN", hole **2** is connected to the drainage hole in the base of the Vapor. The anaesthetic agent from the Vapor flows through hole **2** and through the inner tube of the filling adaptor into the bottle. Saturated vapour from the bottle is routed into the Vapor through hole **1**.

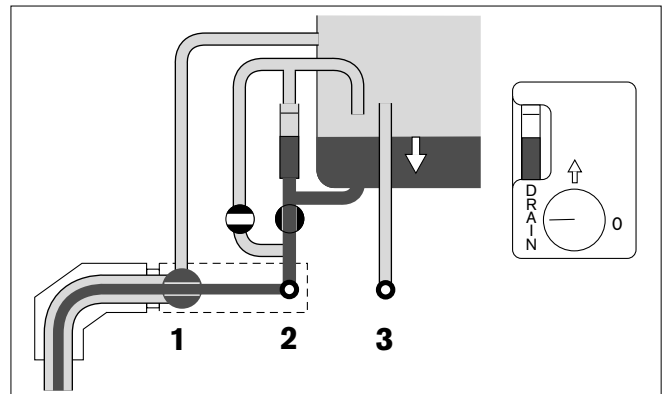

**Operation:**

The valve is switched to »0« and the sealing block on the filling device is replaced to seal the three holes **1**, **2** and **3** when Vapor is to operate.

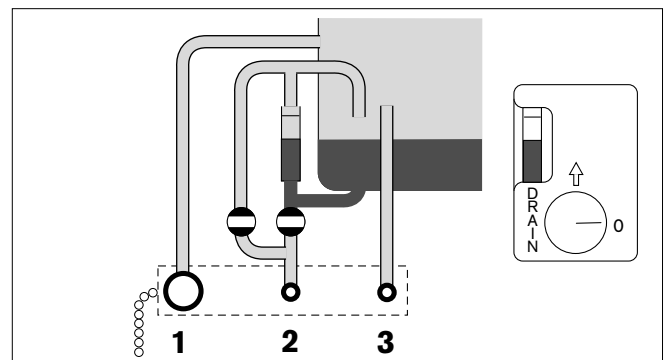

## List of models/options for connection

Vapor and the connections suitable for different Dräger anaesthetic machines are described in brochure "Options for connecting Dräger-Vapors" (SD 5327.20).

### Plug-in adaptor, coded

Vapor 19.3 with plug-in adaptor

Plug-in adapter  
with anaesthetic-agent-specific coding

for Halothane M 30 978

for Enflurane M 30 979

for Isoflurane M 30 980

for Sevoflurane M 32 380

Coded plugs must not be interchanged.

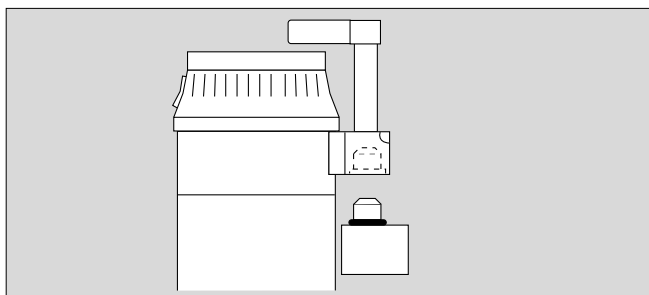

### Plug-in adaptor, uncoded

For Vapor 19.1 with M 25 140 plug-in adaptor without milled corners.

For Vapor 19.3 with M 27 070 plug-in adaptor with milled corners or

M 25 140 plug-in adaptor without milled corners.

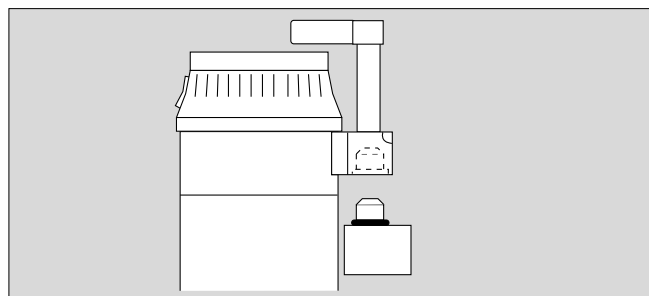

### Plug-in adaptor + Interlock 2

Plug-in system with Interlock 2 for Vapor 19.3 only.

Vapor 19.1 can be modified to Interlock 2 by DrägerService.

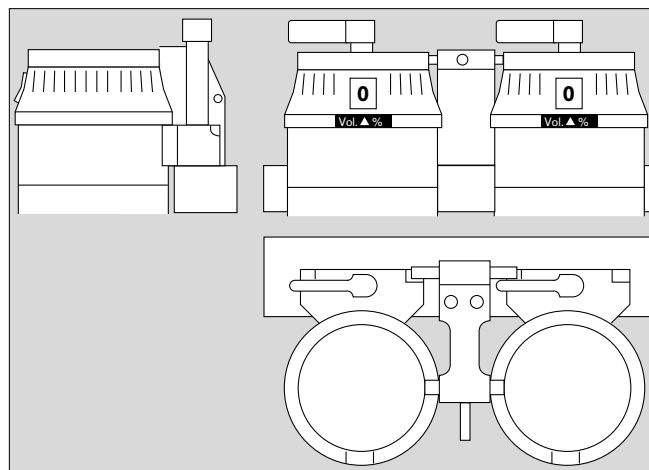

### Permanent connection + 23 mm ISO cones

Vapor ISO connector connecting a Vapor 19.3 (or 19.1) permanently.

(Basic model, permanent connection + M 27 425)

**Vapors must not be switched on in series.**

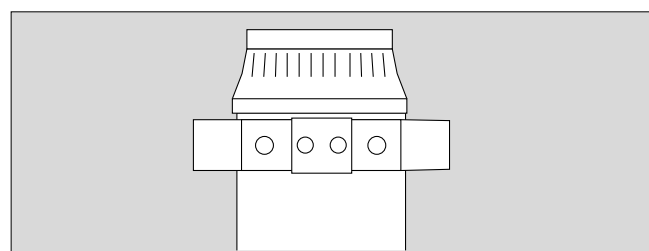

**Permanent connection**

For Vapor 19.3 and 19.1

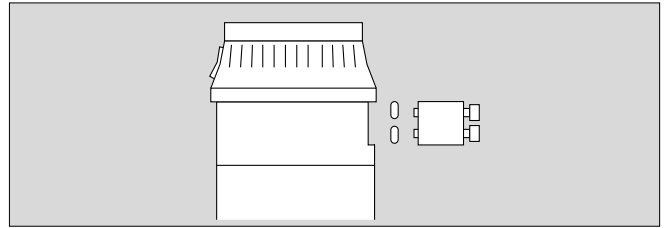

**Permanent connection + Interlock 1**

With permanent connection for Vapor 19.2 only.

Vapor 19.1 can be modified to Interlock 1 by DrägerService.

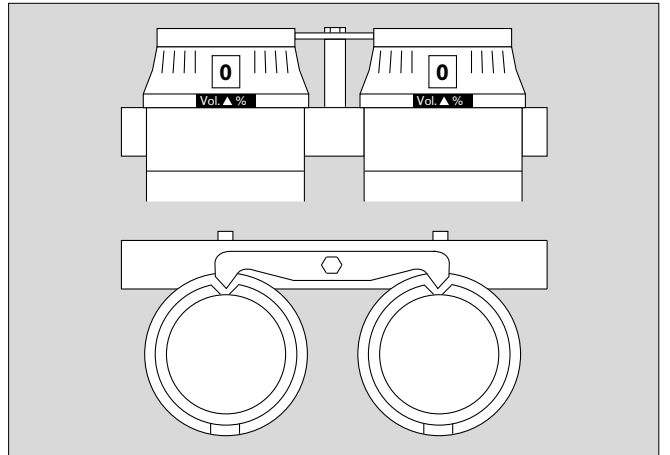

**Plug-in adaptor + 23 mm ISO cones**

Vapor ISO connector plug-in system for connecting Vapor 19.3 (or 19.1) to plug-in adaptor (Basic model plug-in adaptor + M 27730)

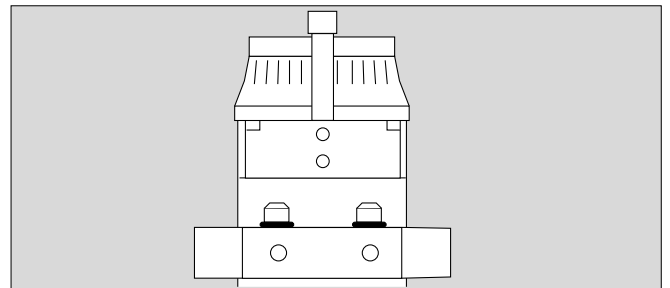

**Hose systems for Vapor 19.3 (19.1)**

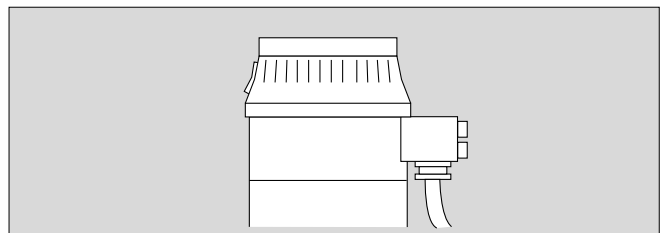

## Vapor connecting systems

Name and Description	Order No.
<b>Interlock system 1 0.5/0.5</b> for permanently connecting two Vapors 19.2	M 27 097
<b>Interlock system 2 0.5/0.5</b> for connecting two Vapors 19.3 with plug-in adaptor	M 27 723
<b>Vapor switching block plug-in system</b> for connecting two Vapors 19.3 (or 19.1) with plug-in adaptors	M 26 615
<b>Vapor switching block</b> for permanently connecting two Vapors 19.3 (or 19.1)	M 25 226
<b>Vapor plug-in system for AV 1</b> for connecting two Vapors 19.3 (or 19.1) with plug-in adaptor	84 06 715
<b>Vapor plug-in system with pin</b> for connecting one Vapor 19.3 (or 19.1) with plug-in adaptor	M 26 588
<b>Vapor plug-in system, rail</b> for connecting one Vapor 19.3 (or 19.1) with plug-in adaptors, mounting for wall rail	M 26 848
<b>Hose connector</b> 160 mm / 120 mm (inlet/outlet) for one Vapor 19.3 (or 19.1)	M 23 805
<b>Hose connector</b> 600 mm / 600 mm (inlet/outlet) for one Vapor 19.3 (or 19.1)	M 22 407
<b>Vapor ISO connector</b> for permanently connecting one Vapor 19.3 (or 19.1)	M 27 425
<b>Vapor ISO connector, plug-in system</b> for connecting one Vapor 19.3 (or 19.1) with plug-in adaptor	M 27 730

## Order List

Name and Description	Order No.
Accessories for key-indexed filling system	
Filling adaptor s for Sevoflurane	M 31 930
Filling adaptor i for Isoflurane	M 30 290
Filling adaptor e for Enflurane	M 30 289
Filling adaptor h for Halothane suitable for Hoechst or ICI Halothane bottles	M 30 288
Parking holder	
Holder for parking position (rail) for mounting to a wall rail, to hold 2 Vapors with plug-in adaptors	M 26 966
Holder for parking position (wall) for permanent attachment to wall, to hold 2 Vapors with plug-in adaptors	M 26 374
For all Vapor 19.n models:	
O-ring	M 21 929
For filling spout:	
Sealing screw	M 26 420
For plug-in system:	
O-ring	U 04 314
Instructions for Use	
German	DB 01050
English	DB 01171
French	DB 01172
Spanish	DB 01173
Italien	DB 01182
Dutch	DB 01183
Swedish	DB 01184
Finnish	DB 01185
Danish	DB 01186

## Index

- A**
- Accessories..... 3
  - Accuracy.....27
  - Ambient conditions .....27
  - Ambient pressure.....37
  - Anaesthetic agent..... 9
  - Anaesthetic agent, boiling point of ..... 33
  - Anaesthetic agent, consumption of..... 28
  - Anaesthetic agent monitor..... 16
  - Atmospheric pressure, influence of.....36
- C**
- Calibration..... 32
  - Care..... 22
  - Cleaning..... 22
  - Colour-coding..... 9
  - Concentration..... 24
  - Connecting system..... 44
- D**
- Dimensions .....8,28
  - DIN 13252..... 7,28
  - Disinfecting..... 23
  - Draining..... 19,21
  - Dynamic pressure ..... 37
- F**
- Filling..... 9,10,13
  - Filling adaptor ..... 6,19
  - Filling level indicator..... 30
  - Filling spout..... 6
  - Filling system, key-indexed..... 6
  - Flow, influence of .....34
  - Flow range.....27
  - Flow resistance.....27
- G**
- Gas composition.....27,35
- H**
- Handwheel..... 5
  - Hose connections..... 15
- I**
- Inspection..... 3,26
  - Installations..... 8
  - Intended use..... 4
  - Interlock.....7
  - ISO cones..... 42,43
- K**
- Key-indexed filling system..... 6
- L**
- Liability..... 3
  - Locking lever, plug-in system..... 5
- M**
- Mechanical stress.....39
  - Method of operation..... 5
  - Models, list of .....42
  - Monitoring..... 16
- O**
- On/off switch.....31
  - Operating principle.....31
  - Operation.....17
  - Order list.....45
  - Overfilling..... 9
- P**
- Packaging..... 26
  - Partial pressure.....32,36
  - Plug-in adaptor, coded..... 29,41
  - Plug-in system..... 5
  - Positive/negative pressure, influence of..... 37
  - Preparation..... 8
  - Pressure changes, influence of.....37
  - Pressure range ..... 27
- R**
- Repair .....3,26
  - Repair, returning for ..... 26
  - Running time, influence of..... 28,38
- S**
- Safety checks..... 3,26
  - Scavenging system..... 16
  - Sealing ring, plug-in system.....5
  - Service.....3,26
  - Set values..... 27
  - Shut-down..... 18
  - Standards..... 28
  - Storage.....21
- T**
- Technical data..... 27
  - Temperature, influence of.....33
  - Temperature range.....33
  - Thymol ..... 22
  - Tilting.....39
- V**
- Vapor models..... 4
  - Vaporiser..... 4
  - Volume percent.....32,36
- W**
- Weight..... 28
  - What's what.....30
  - Wick..... 21,22
- Z**
- Zero-point locking..... 30



These Instructions for Use apply only to  
**Vapor 19.n**  
with Serial No.:

If no Serial No. has been filled in by  
Dräger these Instructions for Use are  
provided for general information only and  
are not intended for use with any specific  
machine or device.



Directive 93/42/EEC concerning Medical Devices

The CE symbol in these Instructions for Use is only valid in  
combination with the CE symbol on the equipment.

**These Instructions for Use also describe a variant with filling  
spout, which does not bear the CE symbol.**

**Dräger Medizintechnik GmbH**

Germany

🏠 Moislinger Allee 53 – 55  
D-23542 Lübeck

☎ (4 51) 8 82 - 0

📠 26 80 70

FAX (4 51) 8 82-20 80

🌐 <http://www.draeger.com>

DB 01 171 - GA 5327.000 e

© Dräger Medizintechnik GmbH

4th edition - June 1998

Subject to alteration

---