

**Baxter**

# PrisMax

Operator's Manual

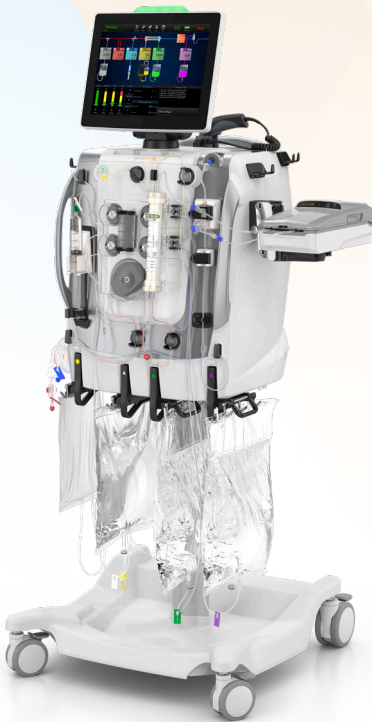

**CE**  
0123

Making possible personal.

# PrisMax Operator's Manual



**Program version: 2.XX**

**Order number:  
AW8035**

## **Trademarks**

**PrisMax** and Baxter are trademarks of Baxter International Inc

## **Legal Manufacturer**



Baxter Healthcare SA

8010 Zurich

Switzerland

# PrisMax overview 5

---

Powering on/off | User interface | System configuration | Cleaning | Maintenance and testing

# PrisMax operating instructions 39

---

Selecting the treatment | Connecting sets and fluids | Priming and connecting the patient | Running the treatment | Stopping the treatment

# Alarms and troubleshooting 91

---

Alarms | Troubleshooting

# General information 171

---

About the general information | Warnings, cautions and notes | Indication for use | Contraindications | Keywords used in this manual | Responsibility and disclaimer | Symbols | Color coding | Certification marks | Installation, service and transport | Disposal

# Therapies 193

---

About the therapies | Abbreviations | Pressure handling (all therapies) | Continuous Renal Replacement Therapies (CRRT) | Therapeutic Plasma Exchange (TPE)

# Device description 233

---

Control unit functions | Flow path management | Fluid management | Air management | Anticoagulation | Components | Control unit | Power control panel | Pumps | Left side panel and drip tray | Pressure sensors and deaeration chamber holder | Pinch valves, return clamp and detectors | Front scales | Miscellaneous components | Back panel | Remote screen viewing | On device training

# Sets and accessories 267

---

Disposable sets | Blood warmers | Auto Effluent (AE) accessory | Other accessories

# Specifications 285

---

Environmental | Physical | Hardware | Medical device classification | Scales | Power | Electrical safety | External interfaces | Compliance | Settings | Displayed data | Syringe | Flow rates and accuracy | Alarm notification | Access line pressure sensor | Return line pressure sensor | Filter pressure sensor | Effluent line pressure sensor | Absolute atmospheric pressure sensor | Air Bubble Detector (ABD) | Blood Leak Detector (BLD) - Effluent | Disposable set specifications | History data | Service specifications | Guidelines and manufacturer's declaration of electromagnetic emissions and immunity | Disposable set life | Supported blood warmers | Logged data | Syringe pump accuracy

# Glossary 341

---

Glossary (alphabetically sorted)

## Chapter 1

# PrisMax overview

|   |           |
|---|-----------|
| <b>Powering on/off</b>  | <b>7</b>  |
| <b>User interface</b>   | <b>9</b>  |
| Using the touchscreen ...   | 9         |
| Toolbar ...   | 11        |
| <b>System configuration</b>                                       | <b>21</b> |
| About system configuration ...                                    | 21        |
| Display ...   | 22        |
| Sound ...   | 23        |
| Advanced settings (site experts and administrator users only) ... | 24        |
| Cybersecurity ...   | 28        |
| <b>Cleaning</b>   | <b>31</b> |
| About cleaning ...  | 31        |
| Cleaning the Blood Leak Detector (BLD) ...                        | 33        |
| Cleaning the touchscreen ...                                      | 33        |
| <b>Maintenance and testing</b>                                    | <b>34</b> |
| Self tests ...  | 34        |
| Preventive Maintenance (PM) ...                                   | 35        |
| Blood Leak Detector (BLD) normalization ...                       | 36        |
| Pressure pod reposition procedures ...                            | 37        |



# PrisMax overview

## Powering on/off



### **WARNING!**

After turning on the control unit, verify that the red status light is lit, and the speaker is activated during the start-up sequence. In case of malfunction, turn off the control unit, unplug the control unit, and call service.



### **NOTE!**

The intended operator position during **PrisMax** operation is by the patient or at the front of the control unit.

Follow these steps to turn the control unit on ( "Power control panel", page 8):

1. Connect the system power cord to AC power. The AC power indicator will illuminate green.
2. Press the green **On/Standby** button. The status light at the top of the display turns green, and the Power-on Screen appears.
  1. If the system passes the Power-On-Self-Test (POST) the Start screen ( "Start screen", page 9) appears. If a POST failure is displayed, reset the system. If the POST failure continues, call service. To power off, press and hold the On/Standby button until the screen turns off.
3. If a filter set, solutions, or bags are already connected to the system, tap the **End** button, and follow the onscreen instructions to remove the components.

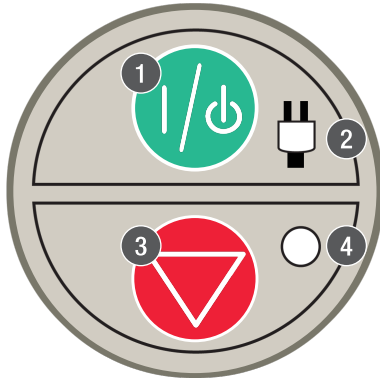

Figure Power control panel

1. On/Standby button: Turns the **PrisMax** system on or places it in standby. When the system is on, the display and all electronics are on. Press and hold to go into standby. When the system is in standby, all electronics are off, except for power supply and battery charging. To completely remove power from the system, disconnect the AC plug from the wall when the device is in standby.
2. Power indicator (green): Alternating current (AC) or battery power connected to the system. On: system running on AC. Off: no AC. Flashing: running on battery or battery charging during standby mode.
3. Stop button: Stops all motors and closes the return clamp. This provides an independent way to stop the device if the screen fails.
4. Stop indicator (yellow): Control unit is stopped (all pumps stopped).



Figure Start screen

## User interface

### Using the touchscreen

The **PrisMax** system uses two types of screens: the Procedure screens and the Operations screen.

The Procedure screens guide the operator through the starting and stopping of a therapy. The Operations screen is the home screen used during therapy.

Any other information is displayed as pop-up windows on the screen. The toolbar is always visible at the top of the screen.

#### **Procedure screen**

See "Procedure screen", page 10, that shows the layout and key elements of a Procedure screen.

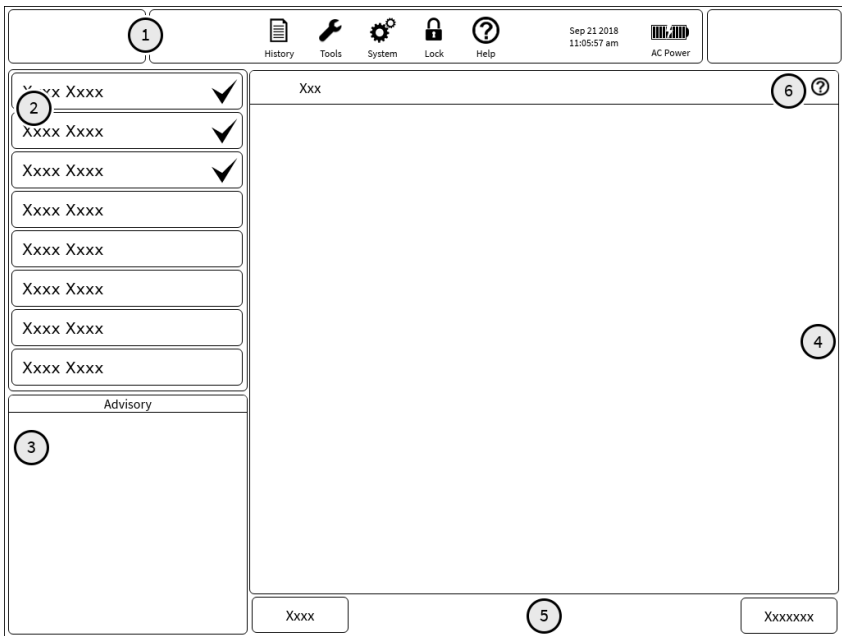

Figure Procedure screen

1. **Toolbar buttons**, see "About the toolbar", page 11.
2. **Procedure steps** in suggested order. The active steps are shown in full color, while inactive steps are dimmed. A check mark shows that a step is complete.
3. **Advisory information** for the current step, if any.
4. **Text and illustration** about the current step. The illustration shows the completed step and not the current status.
5. **Available actions**. Active buttons are in full color, and inactive buttons are dimmed. Tap to perform an action.
6. **Help screen** tap to display a help screen for the current step, if available.

### Operations screen

See "Operations screen", page 11, that shows the layout and key elements of the Operations screen. The screen appears during therapy.

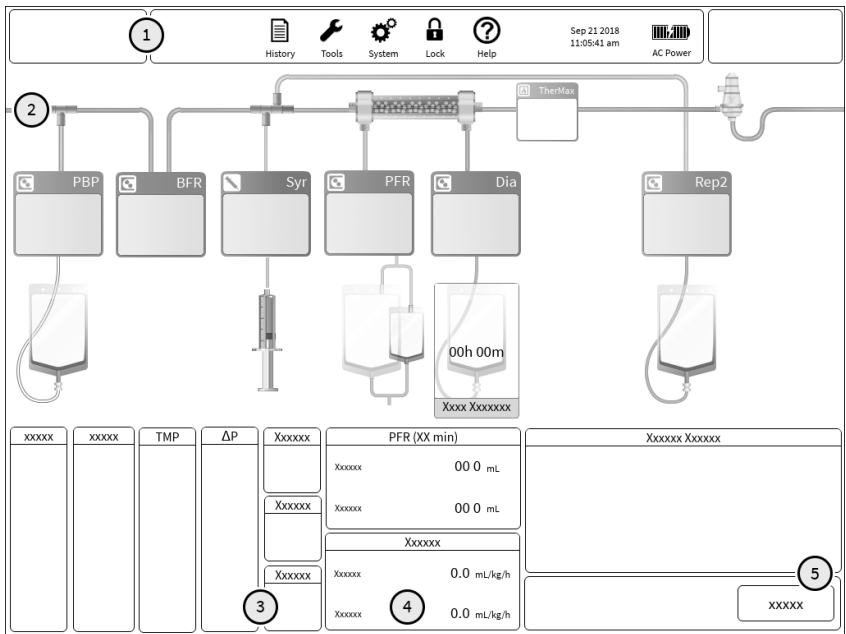

Figure Operations screen

1. Toolbar buttons. See "About the toolbar", page 11.
2. Animated set illustration.
3. Current pressure measurements and limits.
4. Treatment status information.
5. Message center showing the most recent alarms and events.

## Toolbar

### About the toolbar

The toolbar can include the following (not all buttons appear in every situation):

Table **Toolbar**

Current operating mode and therapy. The title of the button changes between **Setup**, **Therapy**, **END**, **B-Recirc** and **S-Recirc** depending on the operating mode of the **PrisMax** system. Tap to view prescription summary. Allows the operator to change patient weight and Hct.



Alarms

Only shown if an active alarm is minimized. The color of the warning triangle is based on the priority of the alarm that is minimized. Tap to view the alarm window.



Override

Only shown if an alarm is currently overridden/alarm off. Tap to view a list of overridden alarms. It is possible to clear all overrides from this screen.



History

Tap to select a history data display (Prescription, Dose, PFR, Events, Pressures, Temperatures). See "History", page 14, for more information.



Tools

Tap to select a system tool, such as normalize blood leak detector (BLD) or adjust deaeration chamber. See "Tools overview", page 15, for more information.



System

Tap to configure the system (display brightness, sound level, or system information). See "About system configuration", page 21, for more information.



Lock

Tap to lock the screen. Protects against inadvertent screen selections and allows cleaning. See "Lock", page 20, for more information.



Help

Tap to view general help information.

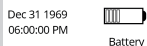

Current date, time, and power source.



AC Power

System running on AC power, battery fully charged.



AC Power

System running on AC power, battery not fully charged.



Battery

System running on battery power.



Battery

System running on battery power, low battery charge.

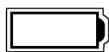

AC Power

System running on AC power, battery not charging.

 Stop

During Setup, tapping the button cancels the setup procedure. During therapy, tap to stop control unit. Stops all motors and closes the return clamp. Select one of the options from the pop-up window (resume treatment, discard set, blood recirculation, or saline recirculation). The button changes title from **CANCEL** to **STOP** to **END** depending on the operating mode of the **PrisMax** system.



Capture

Tap to take a screenshot. This button is only available if previously selected from the Tools menu.

## History



History

The **PrisMax** system continuously stores and updates the control unit conditions and operating data.

Tap the **History** button to view the History screen. See "History screen", page 15. The **History** button is active during Therapy or End mode. It is also active in Setup mode if continuing treatment on the same patient.

| Patient                                  |             | Therapy:CVVHDF             |             |
|--|-------------|----------------------------|-------------|
| Patient ID                               |             | Disposables                |             |
| Secondary ID                             |             | Set                        | Unspecified |
| Weight                                   | -- kg       | Number of Sets             | 0           |
| Hematocrit                               | -- %        | Extracorporeal Bid Volume  | -- ml       |
| Fluid Status                             |             | Set Usage Time             | -- h:min    |
| Gain/Loss Limit                          | -- ml/2h    | Total Treatment Time       | -- h:min    |
| Current Gain/Loss                        | -- ml/2h    | Dose                       |             |
| Current Makeup Value                     | -- ml       | Dose (Eff)                 | -- ml/kg/h  |
| Anticoagulation: Citrate/Calcium Syringe |             | Flow Rates                 |             |
| Citrate                                  |             | Pre Blood Pump             | -- ml/h     |
| Citrate (Dose)                           | -- mmol/L B | Blood                      | -- ml/min   |
| Citrate Solution                         | --          | Dialysate                  | -- ml/h     |
| Citrate Concentration                    | -- mmol/L   | Replacement                | -- ml/h     |
| Citric Acid Concentration                | -- mmol/L   | Patient Fluid Removal      | -- ml/h     |
| Citrate Bag Volume                       | -- ml       | Effluent                   | -- ml/h     |
| Est. Patient Citrate Load                | -- mmol/h   | Return Pressure Drop Limit | -- mmHg     |
| Patient Citrate Rate                     | -- ml/kg/h  | User Set Limit             | -- mmHg     |
| Calcium                                  |             | Enforced Limit             | -- mmHg     |
| Calcium Compensation                     | -- %        | Settings Analysis          |             |
| Calcium Solution                         | --          | Total Predilution          | -- %        |
| Calcium Concentration                    | -- mmol/L   | Post Filter Hematocrit     | -- %        |
| Rep. Solution                            | --          | Filtration Fraction        | -- %        |
| Rep. Calcium Concentration               | -- mmol/L   |                            |             |
| Estimated Patient Calcium Rate           | -- mmol/h   |                            |             |

Figure History screen

History includes I/O data, events, and graphs related to pressures. The I/O data includes the current period and the cumulative fluid removal volumes during treatments.

All events during Setup and Therapy are stored in the order of occurrence in a treatment file. Each event includes a description, time, and date. Graphs of the operating pressures are accessible from the Pressure History screen.

### Saving history data

The **PrisMax** system saves the history data for each treatment as a treatment file. The system stores up to 400 MB of treatment files data. If the memory is full, the oldest treatment file is replaced with the new treatment file. The history data can only be accessed while in Service mode.

## Tools overview



### Tools

Tap the **Tools** button to select a system tool from the pop-up window ("Tools window", page 16).

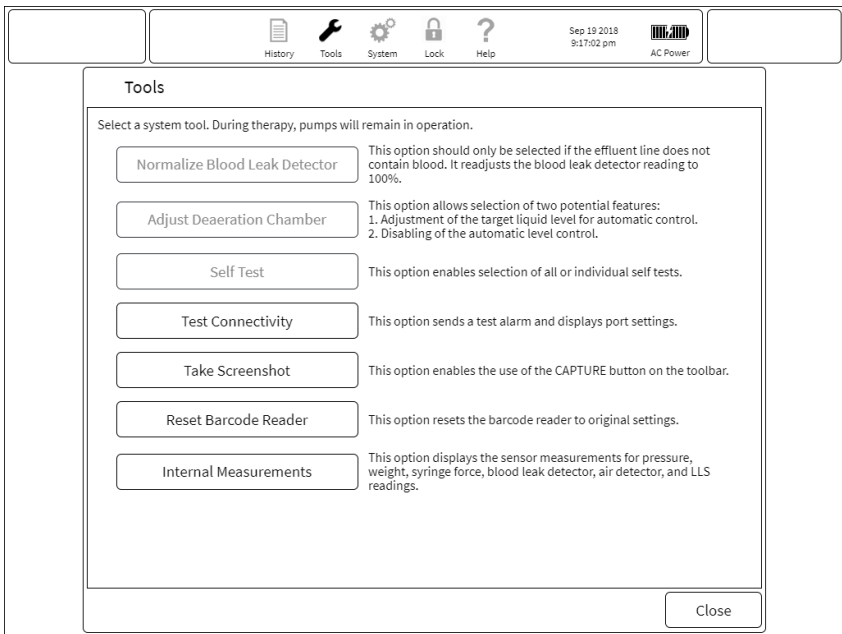

Figure Tools window

## Normalize Blood Leak Detector (BLD)



### **WARNING!**

Fluid in effluent line must be verified to be free of blood before normalizing the blood leak detector.

The **Normalize Blood Leak Detector (BLD)** tool normalizes the detector signal to a value that indicates that no blood is present in the effluent line. The system automatically normalizes the blood leak detector when priming is complete. Use this tool to normalize the blood leak detector if the effluent line is removed and then replaced during treatment.

## Adjust deaeration chamber



### **NOTE!**

Increasing the fluid level in the deaeration chamber draws the excess air into the monitor line and out through the return line pressure port.

The **PrisMax** system automatically monitors and adjusts the fluid level in the deaeration chamber. This tool is available only during therapy and after prime has completed and provides the means to adjust the level that the auto adjustment uses as a target level. Disabling the auto liquid level adjustment for the deaeration chamber allows for manual

adjustment of the level, but fluid leveling will no longer be automatic and subject to flow rate factors.

The fluid level can vary because of events during the treatment. For example, changing a solution bag can introduce a small amount of air into the set.

A fluid level that is too high increases the risk of wetting the return line fluid barrier. A wet fluid barrier blocks the return line, causing the loss of return pressure monitoring.

A fluid level that is too low can cause an alarm because of air bubbles going from the deaeration chamber to the Air Bubble Detector (ABD).

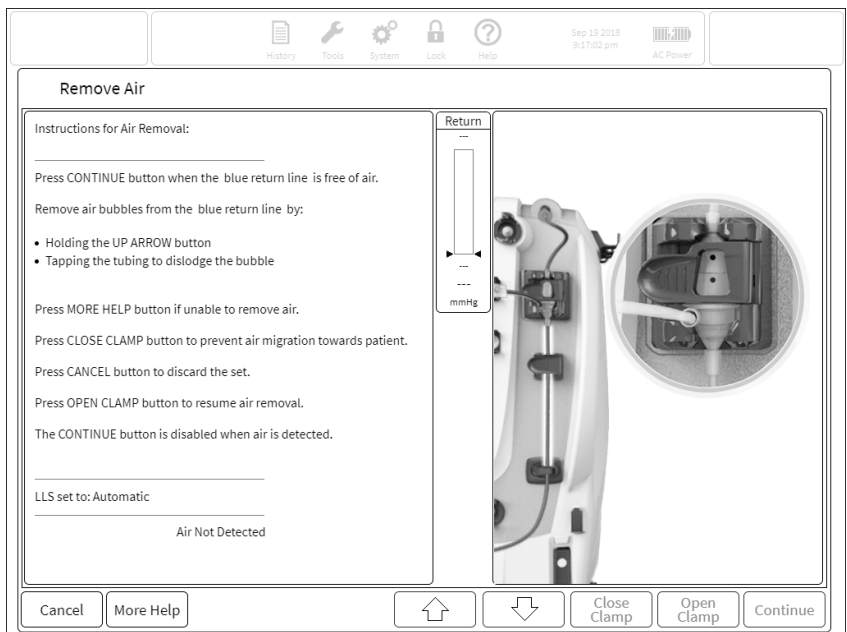

Figure Recommended fluid level

Sometimes a significant amount of foam can form at the top of the deaeration chamber. If the foam reaches the fluid barrier, it can interfere with the return pressure air monitoring and cause alarms. The automatic liquid level function is able to detect foam and will make the appropriate adjustments to try and avoid reaching the fluid barrier. Increasing the post-replacement infusion rate may reduce the amount of foam.

### Initiate self test

The **PrisMax** system automatically does a complete self test ten minutes after the treatment begins and then every two hours after that. If an alarm goes off at the scheduled start of a periodic self test, the periodic self test may be delayed.

The software handles some alarms differently during the self test. Some alarm limits temporarily change or are disabled during the self test.

The self test checks the functionality of the following components:

- Automatic Reposition System (ARPS) pump
- Blood Leak Detector (BLD)
- Discharge ring guide
- Liquid Level Sensor (LLS)
- Pressure sensors
- Return clamp

### **Initiating a self test**

To start a full self test, or an individual test, do the following:

1. Tap the **Tools** button.
2. Tap **Self Test**.
3. Tap **Run All Self Tests**, or tap an individual test.

The status of the self test is displayed when the Self Test window is open. See "Self test window", page 19.

An advisory message shows during the self test in the message center, and the pressure alarm bars turn grey. If any part of the self test fails, an alarm message shows the problem and suggests corrective action. This is available only during therapy.

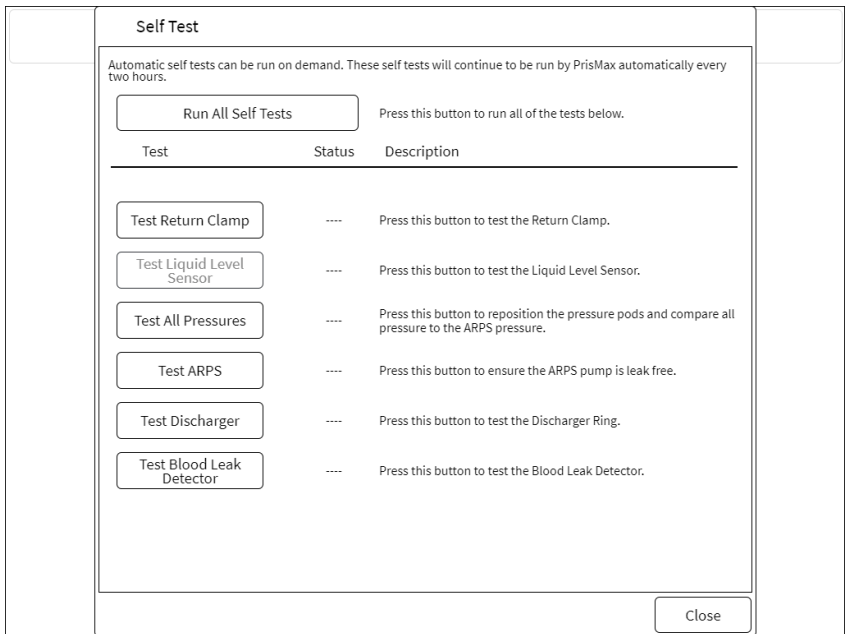

Figure Self test window

## Test connectivity

This tool verifies the function of the control unit back panel connectors by sending a test alarm and toggling the nurse call relay. The Test Connectivity window ("Test connectivity window", page 19) shows the current port settings. Tap the **Alarm** button to generate a test alarm.



Figure Test connectivity window

## Take screenshot



### Capture

This tool takes a screenshot. When selected, an icon appears in the toolbar. When the icon on the toolbar is tapped, the current screen is captured. The image is stored on the system and can be downloaded through the Ethernet port in Service mode.

## Reset barcode reader

This tool displays test codes and reset status. Use the barcode reader to scan the onscreen 2D barcode. This resets the barcode reader in the unlikely event that its configuration changes.

## Internal measurements

This tool displays the **PrisMax** system's current internal measurements for technical reference.

## Lock



### Lock

Tap the **Lock** button from the toolbar to lock the screen. To unlock, tap and hold until the lock window closes. A pop-up window shows when the screen is locked. The lock function protects against inadvertent screen selections and allows touchscreen cleaning without interrupting operation. Alarms automatically unlock the screen.

Clean the **PrisMax** system with typical cleaning and disinfection agents. See "About cleaning", page 31, for more information on cleaning.

# System configuration

## About system configuration

This section describes how to use the System configuration function.

**NOTE!**

The system configuration is left incomplete at the manufacturing facility. The RESPONSIBLE ORGANIZATION must select defaults appropriate to the clinical policies.



### System

Tap the **System configuration** button from the toolbar to view or change the displayed System Configuration settings ( "System configuration screen", page 22). If needed, screens scroll down to show all available information.

The current role (shown at the top right corner of the screen) decides which settings are displayed. Current roles include the following:

- Operator: Typical clinician user. Can adjust display and sound settings.
- Site expert: Password-protected. Lead clinician/education user. Can enable or disable licensed therapies, accessories, disposable sets, and solutions. Only accessible during Setup on the New Patient screen.
- Administrator: Password-protected. Highest authority level. Can enable or disable licensed therapies, accessories, disposable sets, and solutions. Only accessible during Setup on the New Patient screen.

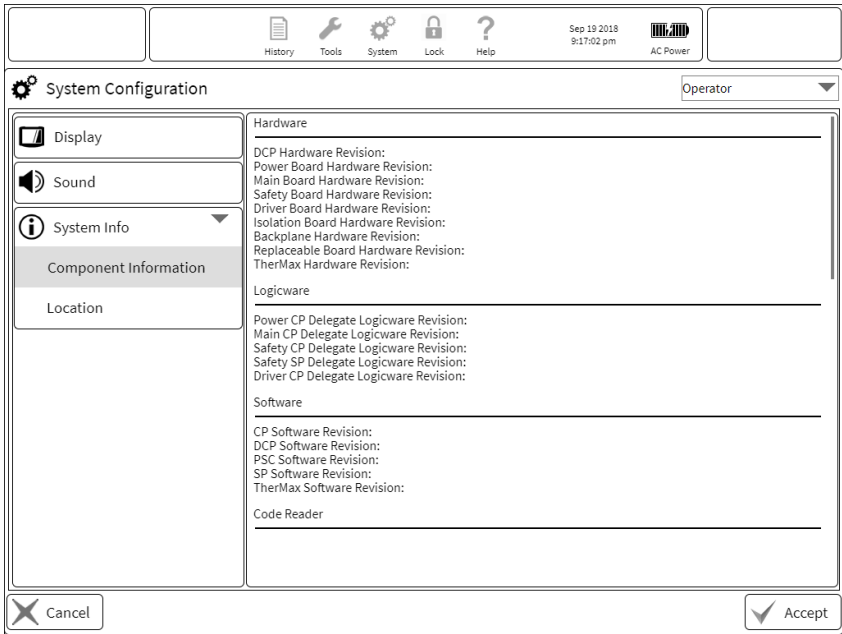

Figure System configuration screen

## Display

### About the display

At the Display screen:

- Set the brightness of the display and status light (the light on top of the display).
- Tap **Display** twice to show sub-screens. (Site expert and administrator users only).
- Select one of the sub-screens.
  - **Operations screen** (site expert and administrator users only)
  - **Date & Time** (site expert and administrator users only)
  - **Language** (site expert and administrator users only)
  - **Passcode** (site expert and administrator users only)

## Operations screen

- Select **Dose Measurement** algorithm (effluent or ultrafiltration rate) for CRRT.
- Select the **Charting Period** (in hours) over which the dose is calculated.
- Select the start of **Charting Period** (in hours) when dose period calculations are to start.
- Select the **PFR Period** (in minutes) over which patient fluid removal is measured.
- Select the **PFR Period Audible Reminder** to check patient fluid removal. The audible reminder consists of a single sound pulse during treatment.

## Date and time

- Set the month, day, and year.
- Set the hour, minute, and am/pm.
- Select the display formats for date and time.

## Language

- Select the language. To put the new language into effect, accept the change, wait 30 seconds, and then restart the **PrisMax** system.

## Passcode

- Use the pop-up keypad to enter the current passcode (an administrator can reset the site expert users password without the current password).
- Enter a new passcode, then re-enter to confirm.
- The new code is activated once all fields are correctly completed and the change confirmed.

## Sound

At the Sound screen:

- **Alarm:** Use this slider control to select alarm volume. A sample tone sounds when your finger lifts from the screen after adjusting the volume. This control does not mute alarm volume.

Following a power cycle, sound volumes return to the default setting of greater than 65 decibels at a distance of one meter.



**NOTE!**

Decreasing the volume below the default settings is not recommended and will be captured in the Alarm off/Override screen.

## Advanced settings (site experts and administrator users only)

### Features screen

The Features screen is available for site experts and administrator users only.

Tap the check boxes to enable therapies and associated disposable sets. Only items available for the machine are displayed.

Tap the button **Features** twice to show the Enable Accessories screen. In the Enable Accessories screen, tap the check boxes to enable accessories for selection during Setup. Only items available for the machine are displayed.

### Containers and solutions

The Containers & Solutions screen is only available for site experts and administrator users. In this screen you can set the following settings:

- default effluent bag size

Tap **Containers & Solutions** twice to display the Syringe Settings screen.

### Syringe Settings

The syringe holder size is shown on this screen. To change the syringe holder size, go to **Service mode**.



**CAUTION!**

Any changes to syringe holder size must be performed by a trained and qualified service technician at installation.

**NOTE!**

If you change the syringe holder size, a new default syringe needs to be selected under the systems menu.

The default syringe brand is highlighted in the list. Tap a different brand in the list to change the default syringe brand.

## Connectivity

**WARNING!**

The **PrisMax** system makes treatment-related data available to connected external devices (personal computer or communication network) for storage and display. This information is intended to support the physician but is not a substitute for clinical verification or judgment. If using a Patient Data Management System (PDMS) with the **PrisMax** system, it is the hospital's responsibility to verify compatibility between the two systems, and to evaluate the risks of any subsequent changes to the PDMS or associated equipment. Using incompatible systems can result in presentation of erroneous data. It is the physician's responsibility to verify all data before prescribing any therapeutic or pharmacological action for the patient.

**WARNING!**

The information provided via the **PrisMax** communications interfaces is intended to supplement the patient treatment data displayed by the **PrisMax** control unit. **PrisMax** communications interfaces information should not be used as the sole basis for medical decisions. If there is a discrepancy between information obtained through the **PrisMax** communications interface and the information shown on the **PrisMax** display, the information shown on the **PrisMax** display is to be considered correct.

**WARNING!**

Connectivity of any network capable device to an enterprise network assumes the possible risk of interference in normal network operations due to device error or device configuration error. The RESPONSIBLE ORGANIZATION must assume all responsibility in mitigating possible negative interference in the enterprise network when connecting **PrisMax** to the network.



**NOTE!**

The Ethernet port is an IP-addressable port for data exchange with a personal computer or communication network. The RS-232 serial communication ports are for data exchange with a personal computer, communication network, or modem.

The network communication function is only for sending data from the machine. No settings in the machine can be changed by sending or receiving data using the Ethernet and serial ports.

To view the connectivity settings for the remote alarm, Ethernet, and RS-232 (serial) ports, tap the **Tools** button, and then tap **Test Connectivity** from the Tools menu.

The Connectivity screen is only available to site expert and administrator users. The Connectivity screen shows the following connection information:

- Media Access Control (MAC) address (display-only)
- Type
  - Select the IP address assignment type, Static, DHCP, or OFF, from the shown list.
- Static IP address (if selected), netmask, default gateway, and DNS server settings
- Serial information
  - Tap in the shown list to select the baud rate.
- Remote alarm
  - Enable or disable remote alarm
    - When the remote alarm is enabled, the relay switches and then an alarm is triggered.
  - Remote alarm type: normally open or normally closed
    - The remote alarm type sets the relay state when no alarm is active.
- Electronic Medical Records (EMR)
  - It is possible to change the EMR ID, change the EMR broadcast interval time, and enable/disable EMR.
- Remote screen
  - Enable/disable a VNC server for remote screen viewing.

## System information

The System information screen shows control unit information including the following data:

- date of the latest preventive maintenance
- date for the next preventive maintenance
- serial number
- installed software version
- lot number
- date of manufacture
- machine acquisition status
- licensed accessories

Site expert and administrator only: Tap **System Info** twice to view the Component Information screen and the Location screen. The Component Information screen shows usage data for technical reference. The Location screen shows hospital contact information.

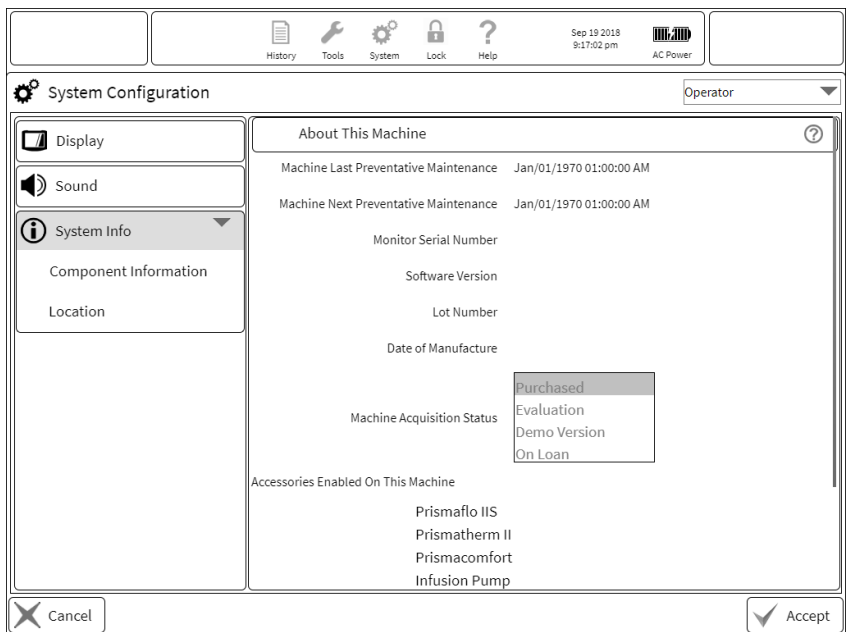

Figure System information

## Cybersecurity



### **WARNING!**

As cybersecurity is a shared responsibility, the following guidance should be considered during implementation:

- Physical access to the device should be limited to only authorized users.
  
- Prepare and perform training for personnel granted elevated privileges on the device, cautioning them against credential sharing and educating them on possible consequences of that for the patient.
  
- Ensure that IT maintain cybersecurity of hospital environment around device by performing following:
  - Network segmentation
  
  - Firewalling each network segment, limiting inbound and outbound connections
  
  - Scanning for unauthorized network access
  
  - Scanning for vulnerabilities and viruses

There are five general categories of cybersecurity controls and risks, associated with the risk of their absence, at the machines installation location. The categories are the following:

| Cybersecurity control | Associated risk   | Recommended practices   |
|-----------------------|---|---|
| Authentication        | Can result in loss of patient data and patient safety risks | <p>Maintain physical security around the PrisMax locations in hospital ensuring that only authorized personal can gain access to the device and dispatch the treatment.</p> <p>Maintain periodic change of passwords for site admins (at least every 90 days).</p> <p>Maintain password rule (strong password, according to latest NIST recommendations).</p> <p>Maintain proper database protection on CIS side, where the passwords would be stored (hashing of the passwords with salt and encrypt database data at rest).</p> |
| Authorization         | Can result in loss of patient data and patient safety risks | Prepare and perform set of training for personnel, granted elevated privileges on device, cautioning them against password sharing and educating them on possible consequences of that for the patient.   |
| Audit                 | Can result in loss of patient data                          | Backup logs from device every two months and maintain log archive for the duration of at least one year.  |

| Cybersecurity control | Associated risk   | Recommended practices   |
|-----------------------|---|---|
| Access Control        | Can result in loss of patient data and patient safety risks | <p>Prepare and perform set of training for IT personnel, cautioning them against giving site admin and service technician levels of access to any other employees except those who absolutely need it.</p> <p>Ensure that IT maintain cybersecurity of hospital environment around device by performing following:</p> <ul style="list-style-type: none"> <li>• Network segmentation</li> <li>• Firewalling each network segment, limiting inbound and outbound connections</li> <li>• Scanning for unauthorized wireless access</li> <li>• Scanning for vulnerabilities and viruses</li> </ul> |
| Cryptography          | Can result in loss of patient data and patient safety risks | Whenever possible, enforce data in transit and data at rest encryption to ensure confidentiality and integrity of sensitive data.   |

**NOTE!**

Call your Baxter representative if a cybersecurity event has occurred involving the **PrisMax** monitor.

# Cleaning

## About cleaning

**WARNING!**

Do not tamper with or modify pumps or protective pump components. If tampering is evident, do not use until an authorized service technician has verified correct system operation.

**WARNING!**

There are no user-serviceable parts inside the control unit. Do not open the control unit or attempt any internal or external maintenance or repair, other than the routine cleaning described in this manual. An authorized service technician must perform all other maintenance and repairs.

**CAUTION!**

To avoid damage to the **PrisMax** system and disposable sets, clean and disinfect the **PrisMax** only as specified in this manual. Use a non-recommended chemical only if specifically authorized to do so by Baxter. Do not use halogenated aromatic and aliphatic solvents or ketonic solvents.

**CAUTION!**

Using a sodium hypochlorite (bleach) solution at a stronger than recommended concentration can cause damage or discoloration.

**CAUTION!**

To avoid damage to the pump crank, do not clean with bleach.

**CAUTION!**

To avoid damage to the bearings, do not submerge the removable pump rotors in cleaning solution.

Clean the exterior of the control unit with typical cleaning and disinfection agents, including the following:

- liquid soap - surfanios wipes
- hydrogen peroxide (0.5%) - Virox
- ethyl alcohol (95%)
- benzalkonium chloride (0.5%) - Sanicloth
- isopropyl alcohol (95%)
- sodium hypochlorite (1.0%)
- benzalkonium chloride (0.28%) and isopropanol (17.2%) - Caviwipes
- o-phenylphenol (0.13%) and ethanol (66.34%) - Citrate germicide

Clean all external surfaces before the first use, after each patient treatment, and as required during treatment:

- Clean spills from the surface of the control unit using a mild detergent.
- Disinfect the surfaces of the machine using a solution of 90% ethyl alcohol, 70% isopropyl alcohol, or 0.1% bleach.

Thoroughly reprocess the device in a comprehensive and methodical manner. Inspect the following items for damaged or exposed internal components which would indicate that the device is at the end of its life or should be serviced.

- Cracked plastic housing and raceways
- Power cord and plug
- Cracked screen
- Damaged labeling
- Dead or flickering LEDs
- Damaged Ports
- Wheels and Breaks

Clean all external surfaces before the first use, after each patient treatment, and as required during treatment:

- Clean spills from the surface of the control unit using a mild detergent.
- Inspect the device following cleaning to ensure all soil is removed. If soil remains repeat cleaning steps in order to ensure that no visible soil is present prior to the disinfection steps, as having residual soil present could prevent adequate disinfection from occurring.
- Disinfect the surfaces of the machine using a solution of 90% ethyl alcohol, 70% isopropyl alcohol, or 0.1% bleach.

Reprocess the device promptly after use in order to minimize soil drying.

## Cleaning the Blood Leak Detector (BLD)

Clean the tubing path through the Blood Leak Detector (BLD) as required to remove liquid or other debris. Use a lint-free cloth and isopropyl alcohol to clean inside the Blood Leak Detector (BLD). Dry thoroughly when finished.

## Cleaning the touchscreen



### Lock

To clean the touchscreen during a treatment, tap the lock icon from the toolbar. This locks the screen and allows cleaning without accidentally pressing any buttons. To unlock the screen, tap and hold anywhere on the display.



#### **CAUTION!**

Using a sodium hypochlorite (bleach) solution at a stronger than recommended concentration can cause damage or discoloration.



#### **CAUTION!**

To avoid damaging the touchscreen, use only recommended cleaning solutions.

# Maintenance and testing

## Self tests

The **PrisMax** software continually monitors the operation of the control unit and the disposable set. This monitoring includes the following tests:

- **Initialization test:** The Initialization test is done at power-on to check the following:
  - control and safety subsystems are operating correctly
  - all communication buses are functional
  - all hardware and software is compatible and correctly installed
  - the protective system can independently disable all actuators
  - all processors operate correctly

If the initialization test is successful, the machine proceeds to Setup and Therapy mode.

- **Prime self test:** The test is done during Setup to make sure the selected set is loaded and is operating correctly. Prime self-testing includes making sure that the pinch valves fully close the effluent and auto effluent lines. This is done by stopping the effluent and auto effluent pumps, then making sure the weight change for the closed bag is near zero.

- **Periodic self test:** The periodic self test is done when manually started or every two hours during the treatment. The test makes sure the system is operating properly during treatment. The first periodic self test starts ten minutes after the treatment begins. A complete periodic self test takes approximately six minutes, and normal operation continues during the test. Software automatically adjusts the periodic self test schedule in case of a clinician intervention, for example, bag change. Pressure management is affected by an ongoing periodic self test. Pressure limits are temporarily disabled during some parts of the self test. Alarms related to this may be postponed until after the test is complete.

Tap the **Tools** button, and then tap **Self Test** to manually start a self test.

- **Background testing:** Software continuously checks the system function when the machine is on. See "Alarm safety and monitoring systems", page 93. If background testing detects an error, an alarm goes off, and the system goes into a safe state that requires service.

If any self test fails, an alarm goes off, and an onscreen message identifies the specific failure and corrective action. See the "Alarms and troubleshooting" and "Maintenance and testing" sections.

## Preventive Maintenance (PM)

The **PrisMax** system requires preventive maintenance (PM) at a minimum interval of 6,000 hours of operation or every 12 months. It also requires a safety inspection every 12 months or as required by local regulations. PM and safety inspections must be performed by authorized service technicians as described in the PrisMax System Service Manual.

Go to System Configuration > System Information to view the PM due date. The machine displays an advisory message when PM is required, which does not affect normal operation. The advisory can only be reset in Service mode.

Scheduled PM procedures include component replacement at the following intervals.

Table Replacement intervals

| Replacement interval      | Component                                 |
|---------------------------|---|
| 6,000 hours or 12 months  | Pressure pod sealing cones - 4 each       |
|                           | Blood pump rotor dampers - 2 each         |
|                           | Fluid pump rotor dampers - 8 each         |
|                           | ARPS filter and pump segment - 1 each     |
| 12,000 hours or 24 months | Pressure pod sealing cones - 4 each       |
|                           | Blood pump rotor dampers - 2 each         |
|                           | Fluid pump rotor dampers - 8 each         |
|                           | ARPS filter and pump segment - 1 each     |
|                           | Replaceable board - 1 each. P/N SC6078    |
|                           | Battery pack - 1 each. P/N SC6061         |
|                           | Barcode reader cable - 1 each. P/N SC6091 |

PM procedures use Service mode to check the proper operation and calibration of the system components. This is described in the PrisMax Service Manual. PM procedures also include the following:

- cleaning dust, debris, and spills from the external and internal machine surfaces, including pump rotors
- checking the proper function and integrity of the blood pump rotor and fluid pump rotors
- cleaning the tubing path of the blood leak detector
- cleaning bar code reader lens

## Blood Leak Detector (BLD) normalization



### **WARNING!**

Before normalizing the Blood Leak Detector (BLD), observe the effluent line fluid to verify that it is free of blood.

The Blood Leak Detector (BLD) is an infrared transmission and detection device that continuously monitors the effluent line for the presence of blood. The blood leak detector is automatically normalized

after the end of the priming sequence when the effluent line is full of priming solution. The blood leak detector must be normalized if the effluent line is removed or reinserted.

The infrared transmitter and detector is adjusted until the received signal is at the target operation point, when the signal value is at 100%. Once normalized, a blood leak detector alarm goes off if the received signal is lower than the the alarm limit of 60.1% at rates under 5000 ml/h. At rates higher than 5000 ml/h the alarm threshold is as high as 73.4%.

Follow these steps to normalize the blood leak detector:

1. Draw a sample from the effluent line, and send the fresh effluent sample to a laboratory to test for the presence of red blood cells.  
If blood is present, end the treatment and change the set. If no blood is present, proceed to the next step.
2. Tap the **Tools** button from the toolbar.
3. Select **Normalize Blood Leak Detector**.
4. Check that the displayed signal value is 85% or greater. If needed, move the effluent line slightly up or down in the blood leak detector to raise the signal value. If the displayed signal value is still below 85%, the Blood Leak Detector (BLD) cannot be re-normalized and the set must be changed. This prevents normalization when there is a blood leak.
5. Tap the Onscreen button to start normalization. The infrared LED drive signal is at 100%. The display goes back to the previous screen when the normalization is complete.

## Pressure pod reposition procedures



### **CAUTION!**

To ensure that pressure monitoring operates correctly, do not delay the self test more than twice in a row.

To reposition the pressure pods, tap **Tools > Self Test**, and then tap **Test All Pressures** or **Run All Self Tests**.



## Chapter 2

# PrisMax operating instructions

## Selecting the treatment 41

---

Getting started ... 41

Power on ... 44

Setup mode ... 45

Patient step ... 47

Therapy step ... 48

Prescription step ... 49

## Connecting sets and fluids 51

---

Sets step ... 51

Fluids step ... 55

Anticoagulation ... 59

## Priming and connecting the patient 61

---

About priming ... 61

Prime step ... 62

Additional priming options ... 63

Review step ... 64

Connect patient step ... 64

## Running the treatment 65

---

About running the treatment ... 65

**Operations screen (Therapy mode) ... 65**

**Changing flow rates, solutions bags and syringes ... 70**

**Pressure and treatment data ... 75**

## **Stopping the treatment 76**

---

**About stopping the treatment ... 76**

**End treatment/discard set ... 77**

**Blood recirculation ... 82**

**Saline recirculation ... 84**

**Manually terminating a treatment ... 87**

# PrisMax operating instructions

## Selecting the treatment

### Getting started

**WARNING!**

To avoid the possibility of injury, lock the wheel brakes to limit movement that could pull on tubing connected to the patient or significantly alter fluid balance.

**CAUTION!**

Allow the control unit to acclimate to ambient operating temperature for at least one hour before use.

**NOTE!**

Ensure all 4 casters are in contact with the floor prior to starting therapy.

**NOTE!**

If necessary when accessories are attached, turn the PrisMax system sideways in order to pass through doorways.



**NOTE!**

To avoid differences between temperature and actual ambient temperature, avoid placing the temperature sensor directly next to HVAC (heating, ventilation and air conditioning).



**NOTE!**

The length of the access and return lines necessitate that the **PrisMax** be within approximately 3 feet of the patient blood access point. There is no specific orientation of the **PrisMax** machine to the patient. However, it is expected that the operator is facing the front of the machine with full physical access to the front and left side (if AE is in use). The LCD screen at the top of the **PrisMax** can be tilted and turned to face multiple positions for ongoing monitoring of the **PrisMax** status by the operator. Care should always be taken to support the access and return lines so that the actual blood access has zero tension on it, and it is unkninked and free running.

To move the **PrisMax** system, release the brakes on all wheels, and move using only the handles. (See "Positioning the PrisMax system", page 43).



Figure Positioning the PrisMax system

1. **Display** Can be rotated 90 degrees (vertically) and 180 degrees (horizontally).
2. **Control unit**
3. **Handles** Use the handles on the front and back to move the control unit as needed.
4. **Wheel brakes**

## Power on

### Instructions

1. Attach the AC power cord to an AC power source.  
Power cords are country specific.
2. To power on the control unit, press the green On/Standby button on the front panel ( "Powering on the control unit", page 44).

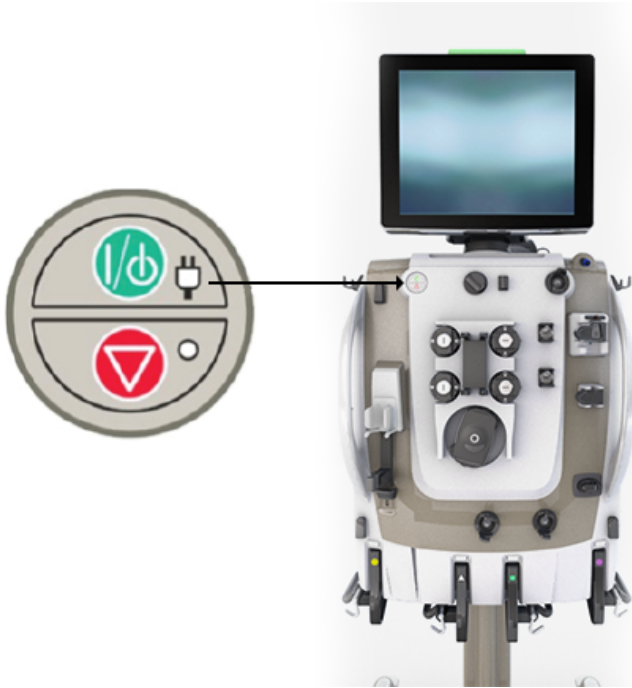

Figure Powering on the control unit

The screen from the most recent mode of operation appears. If no set is attached, the Start screen appears ( "Start screen", page 45).



Figure Start screen

3. To start a new treatment, select **New Patient**. To continue treatment with the same patient, select **Same Patient**.

**Same Patient** is displayed only if settings from a previous treatment were stored. **Same patient** is unavailable after the **PrisMax** has been turned off, or after 12 hours since the last treatment.

## Setup mode

The **PrisMax** system enters Setup mode, if the operator selects **New Patient**. The system goes directly to the **Sets** step if **Same Patient** is selected (see "Sets step", page 51).

Figure Setup mode

- The currently-selected step is highlighted. A check mark indicates when the step is complete.
- Active steps appear in full color. Active steps can be selected in any order. If changes are needed the operator can return to the previous steps.
- Inactive steps are dimmed and may not be selected.
- The screen shows whether entry fields are optional or required. To complete a step, the operator must enter data in all required fields.

The Setup mode guides the operator through the process of selecting a treatment for a patient. It includes the following steps:

**Table Steps for selecting the treatment, connecting sets and fluids, and priming and connecting patient**

|           |  |
|-----------|--|
| 1 Patient | Enter patient ID, weight, and hematocrit.<br>The system directly goes to the <b>Sets</b> step with patient information, therapy, and prescription data automatically filled in, if the operator select Same Patient. |
| 2 Therapy | Select therapy, set, anticoagulation, and accessories such as the Auto Effluent (AE) accessory or a blood warmer.  |

|                   |   |
|-------------------|---|
| 3 Prescription    | Set flow rates, the blood flow rate must be entered first, all flow rates must be entered even if the flow is off (zero), the resulting treatment parameters, and dose information. |
| 4 Sets            | Load the disposable set, connect set components, and install accessories.   |
| 5 Fluids          | Connect priming solution, solution bags, and syringe (if used).   |
| 6 Prime           | Verify prime readiness, start prime, and view the progress of the prime.<br>Additional options are available after the prime is complete.   |
| 7 Review          | View and confirm the prescription before connecting the patient and starting treatment.   |
| 8 Connect Patient | Connect patient (access and return lines), and start treatment.   |

## Patient step

### **Before you start**

Make sure that the **Patient** step is highlighted.

## Instructions

1. Enter patient ID and secondary ID using the pop-up keypad or select either of the fields and scan patient wristband.

Both of these fields are optional.



### NOTE!

The patient ID is hidden by default when using any of the external communication protocols. The responsible organization has the legal responsibility to comply with data security and confidentiality requirements.

2. Enter patient weight, which is used for dose calculations, and patient hematocrit (Hct) value, used to calculate post-filter hematocrit, Hct<sub>post</sub>.

The default Hct value is 30.



### NOTE!

The patient body weight and hematocrit can be changed during therapy by pressing the therapy button in the upper left hand corner, and then pressing **Patient**.

## Result

The **Patient** step is complete when the operator has entered and accepted the values for weight and Hct that are within acceptable ranges.



### NOTE!

The entered patient body weight determines the default value for the gain/loss limit. The gain/loss limit can be further restricted by the applicable range for the selected disposable set.



### NOTE!

The **PrisMax** system encrypts the patient ID when logging data.

## Therapy step

### Before you start

Make sure that the **Therapy** step is highlighted.



### NOTE!

For more specific information and instructions on TPE therapy, see chapter "Therapeutic Plasma Exchange (TPE)" within chapter "Therapies".

## Instructions

1. If the operator selects a profile from the drop down list, it automatically fills the therapy, set and anticoagulation fields.

The profile is deselected if the therapy, set, or anticoagulation settings are changed.

A profile is a starting point for selecting a treatment, and is not required (see section "Profiles", for more information on creating profiles).

2. If no profile is used, select the therapy, set, and anticoagulation manually.

A therapy must be selected first, the therapy selected determines which sets are available.

3. Select any accessories to be used.

The onscreen illustration updates to show the selected items.

## Profiles

1. Use the **Select Profile** button to select a profile.

A profile is a saved prescription setting, including therapy type, set, anticoagulation, and specific flow rates.

The Blood Flow Rate (BFR), PBP, dialysate, and replacement flow rates will be saved in the profile.

A profile can be deleted from the Select Profile dialog window.

2. To save a new profile, complete and verify the prescription and tap the **Setup** button at the top left, then the **Save Profile** button at the bottom of the Review prescription screen.

When the button is tapped, the operator will be prompted to save the current prescription under a user-specified name.

## Result

When the selected therapy, set, and anticoagulation has been accepted, the **Therapy** step is complete.

# Prescription step

## Before you start

Make sure that the **Prescription** step is highlighted.

The screen shows the selected therapy or profile (display-only).

**NOTE!**

For more specific information and instructions on TPE therapy, see chapter "Therapeutic Plasma Exchange (TPE)" within chapter "Therapies".

**Instructions**

1. Select the applicable flow rates for the therapy: set the Blood Flow Rate (BFR) first.

The Blood Flow Rate (BFR) must be greater than 10 ml/min. All pumps display “- -” until a value is set. The **Accept** button is dimmed, and setup cannot continue until all flows are set to a value (even if value is 0 ml/hr).

**CAUTION!**

To avoid the risk of clotting, ensure that the blood flow rate is greater than or equal to the minimum rate specified for the filter in use.

2. To set a flow rate, tap its icon to set the value using the pop-up flow rate adjustor. Swipe up or down on the thumbwheel icon to make swift changes. Use the **+** or **-** buttons to make precise changes.

Attempting to set a flow rate outside its current limits causes an audible tone, and an onscreen message appears. The message describes the limit and which flows, if any, can be adjusted to change the limit.

3. The screen shows treatment parameters, which include the calculated values related to the selected treatment and flows. Treatment parameters also show solutions to be used, if applicable, allow them to be changed, if selected within "Other Settings". Solutions are initially set by default in System Configuration, or by the selected profile.

CVVH and CVVHDF therapies only: when setting the replacement flow, a pre/post selector button shows next to the flow-rate adjustor. Tap to select whether solution is delivered before or after the filter.

4. Tap the **Other Settings** button to view or change settings, including return pressure drop limit (default 70 mmHg), gain/loss limit or Patient Fluid Removal (PFR) Catch-up availability.

**NOTE!**

Changing the return pressure drop limit changes the detection behavior of the Return Disconnect alarm.

**NOTE!**

Changing the Gain/Loss Limit threshold is only available during Setup mode.

**Result**

When the selected prescription settings have been accepted, the **Prescription** step is complete.

## Connecting sets and fluids

### Sets step

**Before you start****WARNING!**

Ensure the correct disposable set is loaded for the selected therapy. Using an incorrect set for the therapy can cause patient injury or death.

**WARNING!**

Use only the disposable sets approved for use with the **PrisMax** system. Using non-approved sets can result in patient injury or death.

**CAUTION!**

Do not use a disposable set if the set or its package is cracked or damaged, or sterilization caps are missing or loose.

**CAUTION!**

To prevent contamination, use disposable set immediately after removing the packaging and sterilization caps.

**CAUTION!**

Do not use the **PrisMax** system without a properly installed and operating fluid barrier.

**CAUTION!**

To minimize cardiac monitor disturbance and avoid possible misinterpretation of ECG artifacts, install the disposable set discharger ring in its guide before connecting a patient to the **PrisMax** system. Follow hospital policy in case of cardiac rhythm disturbance.

**NOTE!**

For more specific information and instructions on TPE therapy, see chapter "Therapeutic Plasma Exchange (TPE)" within chapter "Therapies".

**NOTE!**

When **Same Patient** has been selected and priming a new set with an existing Auto Effluent (AE) accessory, connect the return line to the effluent bag supplied with the new set for priming. Follow the onscreen instructions for more details.

Make sure that the **Sets** step is highlighted.

**Instructions****Disposable set**

If a disposable set is selected, follow these instructions:

1. Scan the set, barcode located on the back.

If the scanned barcode does not match the selected set, a pop-up window asks the operator to scan the correct set. If scanning is unavailable, tap the **Select Set** button and select the set from a drop-down list window.

2. Attach the set cartridge to the loader.
3. Follow the onscreen instructions to complete the components installation, which includes several sub-steps. For some sub-steps, blue circles on the screen show individual actions ("Circles showing individual tasks", page 53). A checkmark on a circle indicates a completed task.
  - Tap a circle to see more detail.

It can take a few seconds for pressure sensors to detect that the set is connected before the checkmark shows.



### WARNING!

Ensure that the machine is not backed up against a wall or object, causing the AE scale to be disturbed.

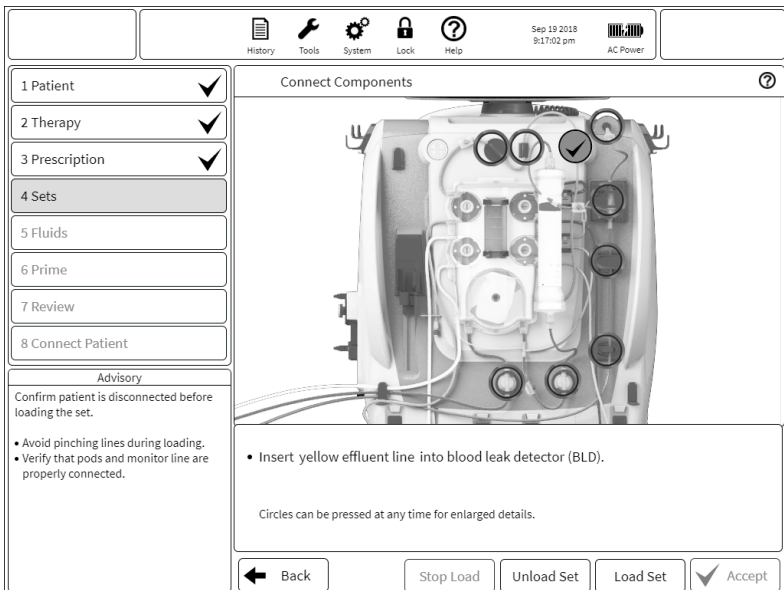

Figure Circles showing individual tasks

## 4. Load the set cartridge.

The **PrisMax** system automatically loads the disposable set, and auto effluent accessory (if used), installing all line segments in the pump raceways.

**Auto Effluent (AE) accessory****NOTE!**

Arrange the Auto Effluent (AE) drain line so that it cannot be stepped on or occluded by equipment.

**NOTE!**

When moving the **PrisMax** system, manage the positioning of the Auto Effluent (AE) drain line.

If the Auto Effluent (AE) accessory is selected, and not being re-used, follow these instructions:

## 1. Scan the AE barcode.

If scanning is unavailable, select the set from a drop-down list window.

## 2. Attach the cartridge to the loader.

The **PrisMax** system automatically loads the auto effluent accessory, installing all line segments in the pump raceways.

## 3. Open the scales, hang the AE bags, and route the lines. Connect the blue return line to the yellow effluent line at the top of the set.

Hang the 1-liter bag on the back scale and the 5-liter bag on the front scale.

## 4. Follow onscreen instructions for connecting the accessory.

It is possible to use an AE accessory with more than one disposable set. If the AE accessory expires during therapy, the option to re-use it will not be available. Change the AE accessory only when replacing the disposable set.

**Blood warmer****WARNING!**

Failure to maintain **PrisMax/TherMax** in a level position can impede the blood leak detection, potentially resulting in severe blood loss.

**CAUTION!**

Do not use a warmer on the replacement or PBP infusion lines: a warmer can generate air bubbles that can collect in the deaeration chamber or filter.

**CAUTION!**

Do not use a warmer on the dialysate line: a warmer can generate air bubbles that can accumulate in the filter/dialyzer dialysate compartment and impair solute transfer.

**NOTE!**

Use only the blood warmers approved for use with the **PrisMax** system, and install and operate according to blood warmer IFU. For information on approved blood warmers, see the "Sets and accessories" chapter of this manual.

**NOTE!**

It is not possible to add a blood warmer after priming has started.

If a blood warmer is selected, follow these instructions:

1. For the **TherMax** blood warmer, follow onscreen instructions for connecting the accessory.
2. For other blood warmers, refer to the blood warmer's Instructions for Use (IFU) for setup information.

**Result**

The **Sets** step is completed when the set has been loaded, components have been attached, and the patient information has been accepted.

## Fluids step

**Before you start**

Make sure that the **Fluids** step is highlighted.

**NOTE!**

For more specific information and instructions on TPE therapy, see chapter "Therapeutic Plasma Exchange (TPE)" within chapter "Therapies".

## Instructions

1. Follow the onscreen instructions.
2. Connect priming solution.
3. After the connections are made to the priming solution bag, tap the **Check** button.
4. Open scales, and hang solution bags.



### **WARNING!**

The scales are high precision devices and may require recalibration if they are abused. Do not strike the scale arms when the scale is opened to change a solution bag.

5. For instructions on how to install the syringe, if applicable, see the "Syringe" section below.

## Syringe

1. If a syringe is selected, follow the onscreen installation steps.

To ensure accurate syringe flow delivery, select the correct syringe brand and size.

An advisory message includes syringe brand, size, and instructions for syringe installation.

## Result

Syringe installation is complete when the syringe test passes and the plunger clip is closed.



### **WARNING!**

Always connect the return line directly to the blood access device. Do not connect additional devices between the return line and/or the blood access device. The use of additional devices, such as three-way valves, stopcocks, or extension lines, may impair return pressure monitoring, and cause damage to blood cells resulting in hemorrhage. Their use can impede the detection of return disconnections which can cause drug delivery inaccuracies and/or failures. The blood access needs to have the ability to supply blood at the rate ordered and return the blood at the rate ordered without interruptions which will cause clotting.

**CAUTION!**

For accurate anticoagulation delivery, ensure the displayed syringe brand and size are correct for the installed syringe.

**CAUTION!**

Before installing the syringe, check for and remove all visible air in the syringe and syringe line.

**CAUTION!**

A non-return valve must be present at the end of the syringe line when the syringe is in use.

**CAUTION!**

When setting up a patient treatment, install only the syringe size/brand that has been enabled for use with the **PrisMax** system.

**CAUTION!**

Use only luer-lock syringes with the **PrisMax** system and closely monitor the syringe line connection.

**CAUTION!**

Ensure the correct dilution of the prescribed systemic anticoagulant is in use.

**CAUTION!**

Even if no anticoagulation is required at the beginning of treatment, it is advisable to select syringe anticoagulation and connect a syringe filled with sterile saline solution. This ensures the syringe line is primed during the automatic priming cycle and is available for anticoagulation at any time during treatment by changing the syringe.

**NOTE!**

To ensure proper flow control of syringe solution, use only syringes approved for use with the **PrisMax** system, possessing verified internal diameters. Any changes to syringe dimensions can affect whether a syringe is appropriate for use with the **PrisMax** system.

**Result**

The **Fluids** step is complete when the bags and syringe have been installed, and the operator has accepted that the bags are installed properly and the lines are connected.

**WARNING!**

For double compartment bags, completely open the press seal between compartments and mix contents well before use. At the beginning of a treatment the system cannot detect if compartments have not been mixed.

**WARNING!**

If applicable, completely break the frangible pin at the bag outlet when using a luer connection to the bag. Push and twist the luer to ensure the connection is secure.

**WARNING!**

The **PrisMax** system cannot detect every situation where a bag is attached to the wrong line or is hanging on the incorrect scale. The **PrisMax** system uses color coded scales with color coded LEDs, lines, and clamps to prevent such errors.

**WARNING!**

Prescribed dialysate solution and replacement solution/fluid must conform to applicable national registration, standards, or laws. If using a commercially available dialysate or replacement solution, ensure that it is labeled as intended for hemofiltration and hemodialysis. For CVVH and CVVHDF, ensure solutions are labeled as intended for intravenous injection. Using non-sterile dialysate or replacement solutions can cause bacterial and pyrogenic contamination.

**WARNING!**

To reduce the risk of incorrect fluid balance, hang only solution bags on the scales, and center each bag on the three-hook carrying bar to evenly distribute its weight. Do not allow foreign objects on the scales, and ensure that bags are supported only by the carrying bars.

**CAUTION!**

Correct scale handling is important to avoid fluid balance errors. Ensure all solution bags hang correctly on the removable carrying bar. Always open the scale when changing a solution bag. Ensure solution lines do not interfere with scales, scale hardware is unobstructed, and there are no fluid leaks.

**NOTE!**

The bag will be shown on the diagram even if the flow rate for the therapy is set to 0 but available for the selected therapy. Hanging the PBP bag is optional if the PBP flow rate is 0, but other solution bags must be hung when shown, even if the associated flow rate is 0.

## Anticoagulation

### About anticoagulation

#### **Anticoagulation**

The syringe pump can deliver anticoagulant to the flow path, that is systemic anticoagulation, and can accommodate various syringe sizes and brands.

The following anticoagulation methods are available:

- None: No anticoagulation. The syringe pump is disabled.
- Systemic anticoagulation: For example, heparin.

It is possible to enable reminders that occur at preset intervals to assess anticoagulation requirements according to hospital policy. A service technician configures the **PrisMax** system with selectable anticoagulation methods. See "About anticoagulation", page 246, for more information on anticoagulation.

If applicable the volume of flows delivered due to anticoagulation is automatically removed by the effluent pump during CRRT therapies.

**NOTE!**

Syringe size is labeled on the syringe clip.

### No anticoagulation

Selecting **None** disables the syringe pump. To enable the syringe during treatment, tap the screen anywhere near the flow rate icons, then tap the **Add Syringe** button to enable the syringe.

### Systemic anticoagulation

**CAUTION!**

Use only the prescribed systemic anticoagulant in the correct dilution.

**CAUTION!**

When setting up a treatment, install only the syringe that has been enabled in System Configuration.

**CAUTION!**

Use only luer-lock syringes with the **PrisMax** machine, and monitor the syringe line connection.

**CAUTION!**

Systemic flow rates at 1mL/hr and below may result in a longer delay detecting a clamped line.

Anticoagulation settings control delivery of physician-prescribed anticoagulant solution from the syringe to the blood-flow path. Anticoagulation can be delivered continuously or in an immediate bolus:

- Continuous: the range of selectable infusion rates depends on the syringe size.
- Immediate bolus: the range of selectable bolus volumes depends on the syringe size.

## Changing the syringe

For Systemic anticoagulation, to infuse anticoagulant between the blood pump and the filter, connect the syringe to the syringe line on the disposable set. Stow the syringe line on the disposable set along the left side of the set cartridge.

Clamp the syringe line when changing the syringe. When the syringe is installed, follow the onscreen instructions to unclamp the syringe line. The syringe flow cannot be changed during a syringe change.

## Recirculation

During saline or blood recirculation, only immediate Systemic anticoagulation boluses can be delivered.

# Priming and connecting the patient

## About priming

Priming flushes disposable set lines with sterile fluid and checks for line occlusions. Priming the set requires at least one priming cycle, and each priming cycle uses a minimum of 1 L of priming solution. The number and type of priming cycles and the time required to complete a prime depends on the set in use. During priming the system verifies proper set installation and displays troubleshooting information if needed (for example, if a line is clamped).

For more information on loading and priming the set, see "Prime step", page 62.

**CAUTION!**

Air detection is disabled during priming. However, during the end of the priming, the system will perform a check if air is present in the return line. Make sure there is no air between the air bubble detector (ABD) and the patient end of the return line before connecting to the patient. If air is present, manual prime can be used to remove air, or use the reprime option if a large amount of air needs to be removed.

**CAUTION!**

If a patient is not connected to the disposable set shortly after priming is complete, flush the set with 1000 ml of priming solution (saline or alkaline solution with pH greater than 7.3) before connecting a patient. This may require a new bag of priming solution and a new, empty collection bag. See the set instructions for priming volume information.

**CAUTION!**

Closely observe the set during priming and operation for leaks at joints and connections within the set, with a potential blood warmer, and from fluid bags.

**CAUTION!**

Blood priming the extracorporeal circuit with citrated blood can result in patient reactions. Check pH and level of ionized calcium in primed circuit prior to patient connection.

**CAUTION!**

Do not allow air to enter the filter blood circuit once priming has started.

**CAUTION!**

Do not connect a patient to the **PrisMax** system before instructed to.

**NOTE!**

Once priming is complete, do not remove the pressure pods from the pressure sensor housings or disconnect the deaeration chamber monitor line from the return pressure port. If any pods are removed, replace the affected pod(s) and reprime the set. If the pod reposition procedure fails, tap the **Tools** button and select **Self-Test** to reposition pressure pods (see "Initiate self test", page 17 for more information). If the monitor line is disconnected, it is necessary to reprime the set and adjust the fluid level in the deaeration chamber if needed.

**NOTE!**

Clamp unused lines after priming is complete and before starting patient treatment. To prevent blood sedimentation, clamp the PBP line if unused.

## Prime step

### Before you start

Make sure that the **Prime** step is highlighted.

### Instructions

1. The screen shows how to prepare for priming the set.

All tubing lines used during treatment must be unclamped for priming.

Instructions remind the operator to inspect lines for air.

When the prime is complete, it is possible to change a bag or container.

Small air bubbles may be present on the tubing wall after the priming cycle is complete.

1. When the prime is complete, inspect the return line for small air bubbles.
2. If air bubbles are present, tap on the return line to dislodge the bubbles while manually priming the set.

Before starting a manual prime, ensure that there is enough solution in the priming bag.

## Additional priming options

When the prime is finished, tap the **More Options** button. Additional priming options are available in a pop-up window. Depending on the selected therapy and set, options include the following:

- **Reprime:** Reprime if air is visible throughout the set or an extended period of time has elapsed since completing the prime. Repriming the set requires at least one priming cycle, and each priming cycle uses at least 1000 ml of priming solution.
- **Flush:** Flushing the set replaces the fluid in the filter in the blood-flow path with fresh solution from the priming bag. For flushing, use a new 1L priming solution bag.
- **Change Bag:** Select the solution bag/container/syringe that needs to be changed.
- **Blood Prime:** Circulates blood product solution through the blood-flow path. The following options are available under Blood Prime:
  - **Manual prime:** Circulates additional priming fluid through blood-flow path under manual control.
  - **Accept:** Tap to go to the **Review** step.

Blood Prime is only available with specific sets. Review disposable IFU for details.

If there is a delay of more than 60 minutes between priming and patient connection, an alarm reminds you to reprime or flush the set.

## Review step

The **Review** step displays the prescription for final review and requires approval before proceeding to the **Connect patient** step.

Now the current prescription can be saved as a profile and used again for future treatments. See section "Profiles", within the "Therapy step", for instructions.

## Connect patient step

### Before you start



#### **WARNING!**

Ensure adequate strain relief is in place for the return cannula tubing before connecting the patient to the **PrisMax** system.

When the prime is complete, follow onscreen steps to connect the set to the patient.

Make sure that the **Connect Patient** step is highlighted.

### **Instructions**

1. Clamp all of the lines as identified on the screen.
2. Disconnect the lines from the Y-connector.
3. Route the lines through the tubing guides as outlined on the screen.
4. (Optional) If re-using the AE set on the same patient, remove the extra 5L effluent bag from the effluent scale.
5. Follow the onscreen instructions to connect the effluent line to the effluent bag or AE set.
6. Follow the onscreen instructions to connect the access and return lines to the patient catheter.
7. Unclamp the lines.
8. Tap the **Confirm all** button.

**Result**

The **Connect Patient** step is complete once the patient connection is confirmed.

A dialog will appear reminding the user to verify line connections. Tap the **Start Treatment** button to enter Therapy mode.

**CAUTION!**

Do not connect a patient to the **PrisMax** system before this step.

**NOTE!**

The pumps do not start until all scales are stable for at least 4 seconds.

**NOTE!**

The user interface reminds the user to unclamp lines attached to the prescribed solutions, and clamp the unused lines.

## Running the treatment

### About running the treatment

This section describes how to use the **PrisMax** system during Therapy mode, including:

- The Operations screen, during treatment
- Changing flow rates, solution bags, or the syringe
- Adding a syringe, if not installed during Setup
- Viewing monitored data

### Operations screen (Therapy mode)

During treatment in Therapy mode ("Operations screen", page 66), the status light is green unless an alarm goes off. Fluid pumps run according to selected settings, and the system monitors bag weights and stores history data. Depending on the type of alarm, alarm detection is enabled at all times, when a patient is connected to the system, or once treatment starts.

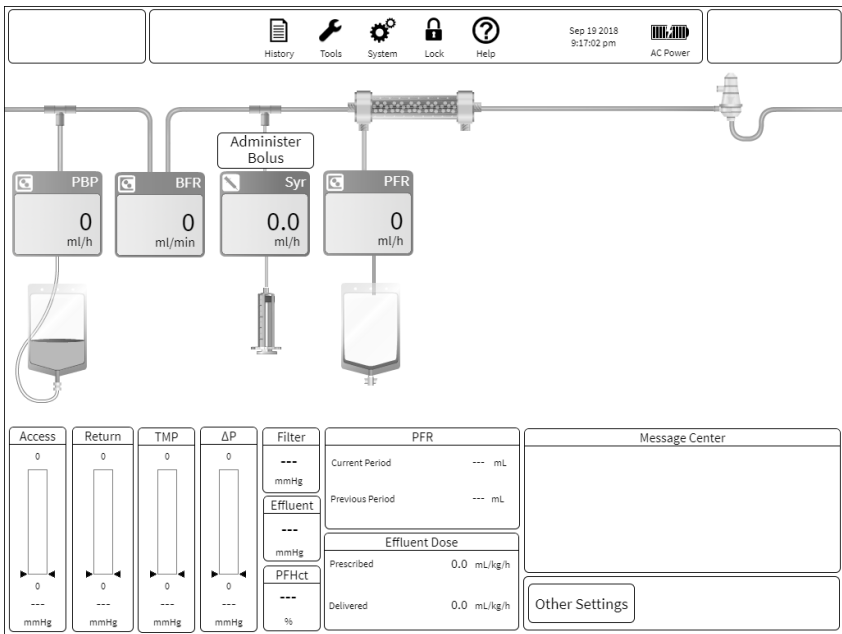

Figure Operations screen

## Table Operations screen

|                             |   |
|-----------------------------|---|
| Flow rates                  | The onscreen illustration shows each flow rate. A dimmed flow rate display indicates the associated pump is not rotating, for example, following a bag change as scales stabilize, or an alarm that stops fluid pumps.  |
| Pressure bars               | The pressure bars indicate the current pressure measurement, operating range, and alarm limits. The therapy in use determines which pressure bars are displayed. (See "Change screen", page 71)   |
| Single data                 | Displays effluent pressure, filter pressure and Post-Filter Hemocrit (PFHct) Treatment status.  |
| Effluent Dose values        | Effluent Dose values are a function of a therapy in use. The Dose display shows the prescription value and what has been delivered. The Dose period is defined by the charting period defined in System Configuration.  |
| Patient Fluid Removal (PFR) | Patient Fluid Removal displays the volume of fluid removed from the patient. The Patient Fluid Removal (PFR) charting period is defined in System Configuration. The chart uses a sliding window based on the period selected. History uses a fixed window for charting purposes. |

|                           |   |
|---------------------------|---|
| Message window            | The message window displays alarms and events in chronological order.   |
| Therapy mode              | Therapy mode displays the therapy in use. Tap this button for additional prescription information.  |
| Time to next intervention | To check when it is time for the next intervention, tap the screen of the <b>PrisMax</b> system. This time estimate is based on the Empty Bag/Syringe Advisory setting in System configuration/Containers and solutions. (See ) |
| Onscreen illustration     | The onscreen illustration shows the therapy configuration for predilution/postdilution, flow rate settings, and volume remaining in the syringe and bags.   |

**WARNING!**

To ensure accurate blood samples, wait a few minutes before taking a blood sample after stopping the PBP pump.

**WARNING!**

Adjust the temperature of the blood warming device according to hospital policy. Global positive heat balance and net patient warming are possible.

**WARNING!**

Follow hospital protocol when connecting to blood access.

**WARNING!**

Air can enter the extracorporeal circuit at connection points downstream of the Air Bubble Detector (ABD), such as a needle or central venous catheter, particularly if circuit pressure is negative at the connection site.

**WARNING!**

The presence of a blood clot or ultrasonic gel can interfere with correct Air Bubble Detector (ABD) operation.

**WARNING!**

Ensure the extracorporeal circuit is not occluded by a kinked blood line or narrow cannula. The **PrisMax** system may not be able to detect all situations that can result in hemolysis.

**WARNING!**

Fluid balance deviations can exceed the tolerance of low-weight patients, even if those deviations are within the **PrisMax** system's accuracy specifications.

**WARNING!**

Extremely negative pre-pump arterial pressure can reduce blood flow, adversely affecting treatment efficacy.

**WARNING!**

To avoid errors in patient fluid balance or fluid removal that could result in patient injury or death, verify fluid removal accuracy. In case of discrepancy between the prescribed value and fluid removed, consult physician and discontinue the treatment as required.

**WARNING!**

The essential performance of PrisMax is net fluid removal. Loss or degradation of net fluid removal due to EM disturbances may cause injury to the patient.

**WARNING!**

Electromagnetic disturbances can cause improper operation, interruption of therapy, resulting in serious injury or death.

**CAUTION!**

Observe the effluent bag for pink or red tinge that can indicate undetected micro-blood leak or hemolysis, if the investigation confirms a blood leak, change the set via STOP. Also consider whether the patient's disease process (rhabdomyolysis, for example) may be the root cause of effluent discoloration. Follow clinic/hospital protocols to mitigate a possible undetected blood leak.

**CAUTION!**

Carefully monitor the patient's blood access and return connections during treatment. Ensure the connections are firmly secured using a strain relief, particularly when a blood warmer sleeve is in use. Carefully observe the set and all operation during patient treatment.

**CAUTION!**

In the unlikely event of a blood/infusion solution leak from a pod diaphragm or wetting of the monitor line fluid barrier (upper right component), the pressure monitoring system is impaired and requires immediate attention. Follow the onscreen instructions to resolve the issue. The most common solution is to replace the set.

**CAUTION!**

To ensure that pressure monitoring operates correctly, do not delay the self-test more than twice in a row.

**CAUTION!**

Carefully monitor the patient for signs of allergic or hypersensitivity reactions, particularly at the start of treatment.

**CAUTION!**

Post-replacement infusion solution flows into the deaeration chamber downstream of the warmer connection, and can reduce blood warmer efficiency when high rates of post-dilution replacement are prescribed.

**CAUTION!**

To avoid the risk of clotting, ensure the blood flow rate is greater than or equal to the minimum rate specified for the filter in use.

**NOTE!**

In case of blood leakage from the pressure pod diaphragm (access and filter), quarantine the device at the end of the treatment. Label the device as out of service until it is checked, cleaned, and disinfected by a qualified service technician.

**NOTE!**

To reduce the risk of early clotting at the top of the chamber when operating without post-replacement infusion, adjust the deaeration chamber level to about 1 cm below the usual level if automatic liquid leveling is disabled. Using a post-replacement infusion creates a stable layer of infusion fluid at the top of the chamber that prevents air-blood interface that can lead to clotting. See "Adjust deaeration chamber", page 16, for more information on using the **Tools** button to select the Adjust Deaeration Chamber tool.

**NOTE!**

Increasing the fluid level in the deaeration chamber draws the excess air into the monitor line and out through the return line pressure port.

**NOTE!**

For best performance, change CRRT sets after 24 hours of use.

**NOTE!**

The alarm log is updated every second to maintain the log in case of a shutdown or complete loss of power.

**NOTE!**

Patient fluid removed can differ from the selected PFR rate if treatment is stopped, or an alarm occurs that stops the pumps.

**NOTE!**

Disturbing a bag or scale for 60 continuous seconds causes a scale unstable alarm, when this alarm is active, all fluid pumps stop.

## Changing flow rates, solutions bags and syringes

### Before you start

The Change screen ( "Change screen", page 71) shows only the items that can change. It does not show the flow path. Displaying the Change screen does not interrupt normal operation, but some actions, for example, changing a bag, can temporarily stop pumps.

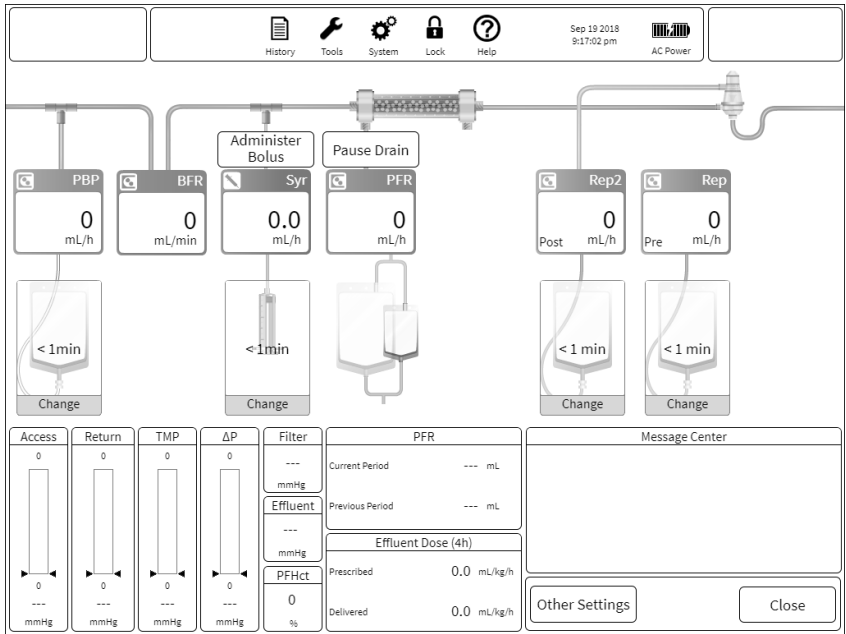

Figure Change screen

This section describes how to change **PrisMax** settings during Therapy mode:

### Instructions

1. To change a flow rate, tap the flow value that needs to change, then use the pop-up flow-rate adjuster to select a new flow rate ("Changing a flow rate", page 74).

It is possible to change more than one flow, and then accept all changes at once. Note that changing flow rates also changes the dose information.

Some flow rates are related to each other. If a limitation is reached, a window will show potential resolutions.

2. To change a bag, tap the graphic, and follow the onscreen instructions.
3. Open the scale completely, and clamp the line when changing a bag.

The display shows the opened scale with color and shape coding. A message showing the time remaining until the next change is shown over the next bag due to be changed.

4. To change a syringe, tap the graphic, and follow the onscreen instructions.

The display shows the syringe. A message with the time remaining until the next change appears over the syringe icon.

5. If systemic, syringe-only, anticoagulation is active, tap the **Bolus** button to deliver an immediate bolus of anticoagulant. In the pop-up window, confirm bolus delivery.
6. If systemic, syringe-only, anticoagulation is inactive, tap the **Add Syringe** button during therapy. To install the syringe, follow the onscreen instructions. Change the syringe flow rate from its initial value of 0 ml/h to start systemic anticoagulation.
7. If the Auto Effluent (AE) accessory is active, tap the button to pause or resume draining.
8. To assign replacement fluid to pre-dilution or post-dilution, tap **Pre** or **Post** buttons, if applicable.

9. To accept setting changes, tap the **Confirm All** button. To return to the Operations screen without making changes, tap the **Cancel** button.
10. Tap the **Other Settings** button to change any of the following:
  - Return disconnect limit: The maximum return pressure drop that is allowed before triggering a return disconnect alarm. (All therapies)
  - PFR Catch-up: Selects compensation for patient fluid removal (PFR) that does not occur during bag changes or when the effluent pump is paused. PFR Catch-up can compensate for up to 10 minutes of PFR downtime in each instance. As makeup occurs and downtime period is reduced below 10 minutes, additional treatment pauses will capture up to a maximum of 10 minutes. Makeup is limited to 20% of the prescribed PFR or 2 ml/kg/h × patient weight in kg, whichever is less.
  - Gain/loss limit is the maximum allowable fluid imbalance (in ml/3h) that can occur before the set must be changed.

**WARNING!**

Certain setting changes during the treatment can increase the risk of releasing a clot to the patient. Verify that no clots are present in the set following a setting change.

**WARNING!**

Closely monitor patient's clotting parameters during use, especially when increasing the anticoagulant delivery or changing the anticoagulant syringe.

**CAUTION!**

Changing therapy settings that imply the use of lines containing non-circulating fluid (for example, changing the pre- and post-filter options to deliver replacement solution, or starting PBP use) during the treatment can increase the risk of clot release to the patient. Verify that no clots are present in the line before use.

**CAUTION!**

Correct scale handling is important to avoid fluid balance errors. Ensure all solution bags hang correctly on the removable carrying bar. Always open the scale when changing any bag. Ensure solution lines do not interfere with scales, scale hardware is unobstructed, and there are no fluid leaks.

**CAUTION!**

Closely monitor the liquid level of the deaeration chamber if automatic fluid leveling is disabled: a significant amount of air may reach the flow path during bag change.

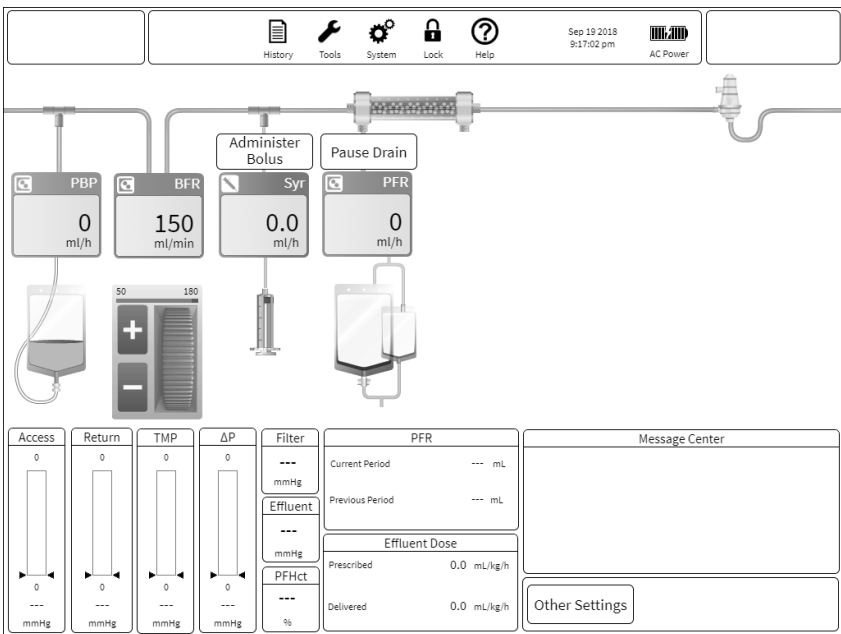

Figure Changing a flow rate

**NOTE!**

Clamp the syringe line when changing the syringe. Once the syringe is installed, follow the onscreen instructions to unclamp the syringe line.

**NOTE!**

Disturbing a bag or scale for 60 continuous seconds causes a scale unstable alarm, when this alarm is active all fluid pumps stop.

## Pressure and treatment data

During therapy, the Operations screen displays data that is monitored during treatment ("Monitored data display", page 75).

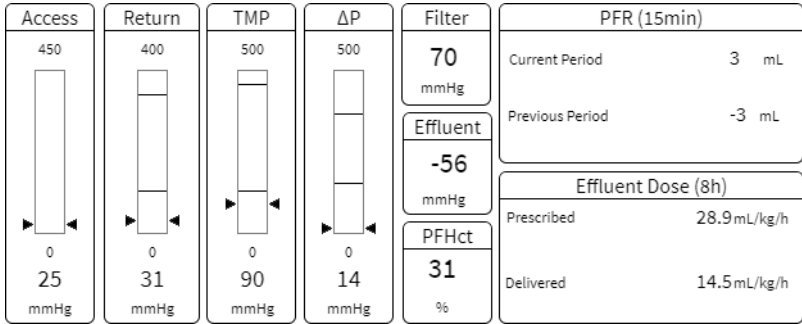

Figure Monitored data display

Displayed pressure bars:

- All therapies: access, return, and filter pressure drop ( $\Delta P$ ) pressures
- Transmembrane pressure (CRRT: TMP, TPE: TMPa)

Pressures are displayed in the form of pressure bars that show the normal operating range (green), advisory pressure levels (yellow), and warning limit levels (red). A numeric pressure level is also displayed.

Pressure bars are gray when operating ranges are being established and during self test.

Single data displays:

- Effluent pressure
- Filter pressure
- Post-filter hematocrit (PFHct) treatment status
- CRRT:
  - Patient Fluid Removal (PFR) during current and previous PFR period. The period is displayed on the screen. This is a sliding window based on the period selected. History uses a fixed window for charting purposes.
  - Effluent dose compared to prescribed delivered dose for the displayed charting period.

**WARNING!**

To avoid errors in patient fluid balance or fluid removal that could result in patient injury or death, verify fluid removal accuracy. In case of discrepancy between the prescribed value and fluid removed, consult physician and discontinue the treatment as required.

**CAUTION!**

Monitor the set carefully for coagulation and associated medical hazards to avoid clotting. Clotting creates resistance as blood flows through the filter, increasing the filter pressure drop and/or the transmembrane pressure (TMP).

**CAUTION!**

Monitor patient fluid balance and plasma balance levels carefully during treatment according to hospital policy, including totals of fluid input/output. Consult Status and History screens when charting fluid balance status.

**NOTE!**

Patient fluid removed differs from the selected PFR rate if treatment is stopped, or an alarm occurs that stops the solution pumps.

## Stopping the treatment

### About stopping the treatment

To stop treatment and proceed to End mode, tap the onscreen **Stop** button at the Operations screen, and select one of the options from the pop-up window ("Stopping treatment", page 77). End mode allows the operator to end treatment or start recirculation. The **Stop** button should only be used for these options.

To minimize alarms, tap the **Dock** button. To adjust settings or change solutions, tap any of the flow rate icons. To bring the system to a safe state, press the red Stop button on the front panel.

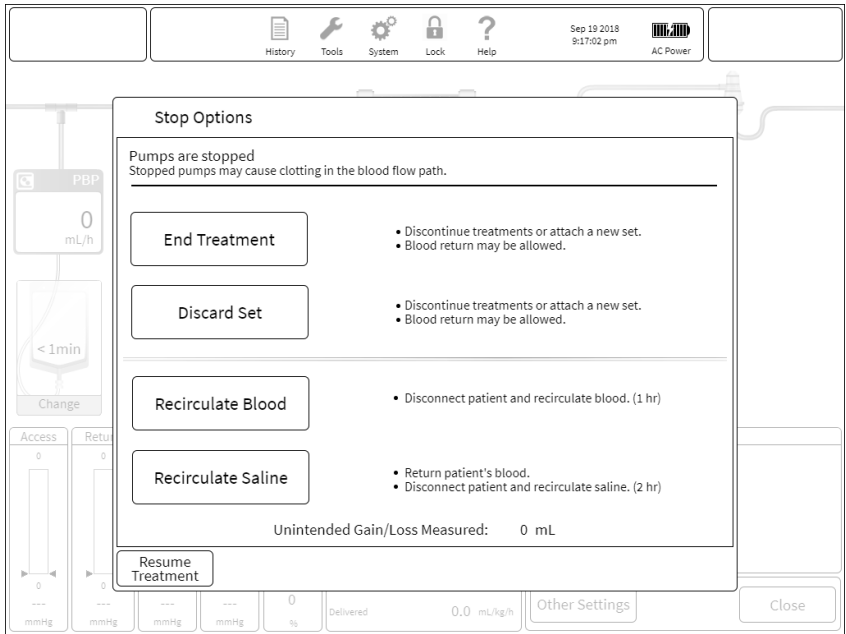

Figure Stopping treatment

Stop options:

- **End treatment/discard set** (see "About end treatment/discard set", page 77).
- **Recirculate blood** through the set, treatment temporarily interrupted (see "About blood recirculation", page 82).
- **Recirculate saline** solution through the set, treatment temporarily interrupted (see "About saline recirculation", page 84).

Tap the **Resume Treatment** button to exit and resume treatment.

It may not be possible to resume treatment at the same stage as when Stop was pressed. Use Stop only to bring the system to a safe state or to enter End mode or Recirculation.

## End treatment/discard set

### About end treatment/discard set

The system enters End mode if the **End Treatment** or **Discard Set** buttons are tapped ("End treatment / discard set", page 78). Once End mode has been entered it is not possible to go back to previous screens.

|   |  |                                       |
|---|--|---------------------------------------|
|   | History          Tools          System          Lock          Help | Sep 19 2018<br>9:17:02 pm<br>AC Power |
| 1. Schedule ✓<br>2. Disconnect Patient<br>3. Remove Set(s)<br>4. Discard Fluids<br><br>Advisory | End Treatment / Discard Set  |                                       |
| Select 'New Patient'/'Same Patient'/'Discard All' first   |  |                                       |
| Same Patient <input type="checkbox"/> Discard All <input type="checkbox"/>                      |  |                                       |
| New Patient <input type="checkbox"/>  |  |                                       |
| <hr/>   |  |                                       |
| Blood Return is not always available due to risks of returning clots or air to the patient.     |  |                                       |
| Return Blood      Yes <input type="checkbox"/> No <input type="checkbox"/> N/A                  |  |                                       |
| <hr/>   |  |                                       |
| Reuse Fluids      Yes <input type="checkbox"/> No <input type="checkbox"/> N/A                  |  |                                       |
| Reuse Auto Effluent <input type="checkbox"/> <input type="checkbox"/> N/A                       |  |                                       |
| <input checked="" type="checkbox"/> Accept  |  |                                       |

Figure End treatment / discard set

1. Select one of the following:

- **Same Patient:** Replace set, and restart treatment on the same patient.



**NOTE!**

Same Patient is not available after **PrisMax** has been turned off. Same Patient is also not available if more than 24 hours have elapsed since the previous treatment.

- **New Patient:** Replace set, and start treatment on a new patient.
- **Discard All:** Discard set without starting a new treatment.

2. Select whether to return blood in the set to the patient before removing the set.

Blood return may not be active based upon alarm conditions.

3. If **Same Patient** is selected, choose whether to keep using the currently attached fluids, syringe, Auto Effluent (AE) accessory, according to hospital policy.

## Return blood

### Before you start



#### **NOTE!**

This procedure may require a sterile spike connector to connect to the sterile saline bag. Any remaining solutions can be used with a new set as needed.

Blood return is used to maintain the patient's blood volume stability. As treatment starts, the patient's blood volume fills the filter set. At the treatment end, per hospital/clinical policy, the patient's blood can be returned. Saline is used starting at the access port to push the extracorporeal blood back to the patient using the blood pump.

An automatic option is available (unless blood prime had been performed), **PrisMax** will run the blood pump to return the exact volume of the circuit set plus accessories. Due to the mixing of blood and saline as the saline pushes the blood back to the patient, the operator can press and hold manual return to return any blood left in the circuit set after the automatic return.

A manual blood return option is available, allowing the operator to press and hold the button and control exactly how much blood to return. Using manual blood return, **PrisMax** allows the operator to return up to 50 % more of the extracorporeal blood volume using the manual blood return. Responsibility for the manual return is the operator's and should be performed per clinic/hospital policy.

## Instructions

1. To prepare for the blood return, follow the onscreen instructions, and then confirm that all preparation steps are complete.
2. Select automatic or manual return.

For automatic blood return, select the blood return percentage (up to 100% of the set blood volume plus accessories) and the flow rate for the return.

For manual return, press and hold to return blood under manual control. Select the blood volume percentage and flow rate for the return (up to 150% of the set blood volume).

The screen shows the progress of the blood return.

Once blood return stops, you can proceed to the patient disconnect step. During this step, you will be instructed on how to clamp all connections associated with the access and return lines. Once done and confirmed on the GUI, the **PrisMax** will perform a test to ensure the access and return lines are clamped.

If clotting has been observed while preparing for blood return, this step can be skipped. To skip this step and proceed with disconnecting the patient, tap the **Back** button, then the **Skip Return** button (see "Disconnect patient step", page 81).

## Result



### WARNING!

Ensure the patient is disconnected from the set before removing the set from the control unit or starting recirculation.



### CAUTION!

Always inspect the flow path for signs of clotting before returning the blood in the set to the patient. Do not return the blood to the patient if clotting is suspected.



### CAUTION!

To avoid returning air to the patient, the return line must be installed in the return line clamp. If an alarm indicates the return line is not installed in the clamp, install the line in the clamp.

**NOTE!**

If the extracorporeal blood volume is a critical factor in the patient's fluid balance, then the extracorporeal blood may be returned to the patient. The operator has two options for this feature. The system can automatically return 0-100% (default 100%) of the extracorporeal blood volume.

Alternatively, the **Manual Return** button may be pressed and held to return the blood.

**Settings and displays during blood return**

- Blood volume to return: the blood volume of the set.
- Return rate: the speed of the blood pump during blood return. The default return rate is different depending on the set in use.
- Volume returned: the volume returned compared to the set volume.
- Set volume returned percentage: the percentage of blood volume returned compared to the set volume. The maximum is 150% (100% for automatic return) of set blood volume. The default is 100% of set blood volume.

**Disconnect patient step****Before you start**

Make sure that the **Disconnect patient** step is highlighted.

**Instructions**

1. Follow the onscreen instructions for clamping and disconnecting the lines, then confirm that all disconnection steps are complete.

System testing confirms that access and return lines are clamped before unloading the set. If the pressure pods have been removed before unloading the set, reconnect the pods and the return port line from the chamber. Before the test can be overridden, system testing must be repeated.

**Remove set(s) step****Before you start****NOTE!**

When the **Prismaflex** set is discarded, the **TherMax** blood warmer disposable remains attached to it and is also discarded.

Make sure that the **Remove set(s)** step is highlighted.

## Instructions

1. To unload and discard the set, follow the onscreen instructions.

### Remove and discard Auto Effluent (AE) accessory

1. To unload and discard the accessory, follow the onscreen instructions.

The system allows for emptying of the auto effluent accessory fluid bags before unloading the set. If this is selected, the **Unload Auto Eff** button will not be available until the bags are completely drained.

## Discard fluids step

### Before you start

Make sure that the **Discard fluids** step is highlighted.

### Instructions

1. To discard the solutions that are currently attached, follow the onscreen instructions.

### Remove and discard syringe

1. To unload and discard the syringe, follow the onscreen instructions.

# Blood recirculation

## About blood recirculation

Blood recirculation may be necessary if the patient needs to be temporarily disconnected from the set.

The **PrisMax** system can recirculate blood in the set for up to 60 minutes before reconnecting the patient. Blood recirculation includes the following steps:

- Preparing for blood recirculation
- Blood recirculation
- Reconnecting the patient

## Prepare for blood recirculation

### Before you start

On the Prepare for Blood Recirculation screen, do the following:

### Instructions

1. To disconnect the patient and rearrange the set for blood recirculation, follow the onscreen instructions.

These instructions include the following:

- Hanging a new 100 ml priming bag with a Y-line
  - Disconnecting the patient and configuring the lines for recirculation
2. To confirm that all blood recirculation preparation steps are complete, tap the **Confirm** button, then start blood recirculation.

## Recirculate blood

### Before you start

On the Blood Recirculation screen, recirculation time remaining is displayed.

### Instructions

1. To adjust Blood Flow Rate (BFR), tap the **BFR** icon.

Continuous anticoagulation is suspended during recirculation.

2. To deliver a bolus of anticoagulant, if systemic anticoagulation is in use, tap the **Syringe** icon.

3. To end blood recirculation and reconnect the patient or discard the set, tap the **Stop** button.

Some alarms are disabled during recirculation because the system is no longer attached to the patient.

## Reconnect patient

### Before you start

On the Reconnect Patient screen, do the following:

**Instructions**

1. To reconnect the patient and set, follow the onscreen instructions, and then confirm that all steps are complete.
2. To resume treatment when all reconnection steps are confirmed, tap **Start Treatment**.

## Saline recirculation

### About saline recirculation

Saline recirculation may be necessary if the patient needs to be temporarily disconnected from the set.

The **PrisMax** system can recirculate saline in the set for up to 120 minutes before reconnecting the patient. If there is clotting in the set, unload the set and do not return blood to the patient. Saline recirculation includes the following steps:

- Returning the blood in the set to the patient
- Saline recirculation
- Priming the set
- Reconnecting the patient

**WARNING!**

Following saline recirculation, prime the set with a new 1-L saline solution bag immediately before reconnecting the patient. Replace the set if the maximum recirculation time is exceeded.

### Return blood

**Before you start****NOTE!**

This procedure may require a sterile spike connector to connect to the sterile saline bag. Any remaining solutions can be used with a new set as needed.

At the Return blood section:

## Instructions

1. To prepare for the blood return, follow the onscreen instructions, then confirm that all preparation steps are complete.
2. Select automatic or manual return.

For manual return, press and hold to return blood under manual control. Select the blood volume percentage and flow rate for the return (up to 150% of the set blood volume).

The screen shows the progress of the blood return.

Once blood return stops, the patient can be disconnected.

To skip this step and proceed with disconnecting the patient, tap the **Back** button, then the **Skip Return** button (see "Disconnect patient step", page 81).

## Result



### **WARNING!**

Ensure the patient is disconnected from the set before removing the set from the control unit or starting recirculation.



### **CAUTION!**

Always inspect the flow path for signs of clotting before returning the blood in the set to the patient. Do not return the blood to the patient if clotting is suspected.

## Settings and displays during blood return

- Blood volume to return: the blood volume of the set.
- Return rate: the speed of the blood pump during blood return. The default return rate is different depending on the set in use.
- Volume returned: the volume returned compared to the set volume.
- Set volume returned percentage: the percentage of blood volume returned compared to the set volume. The maximum is 150% of set blood volume. The default is 100% of set blood volume.

## Recirculate saline

### **Before you start**

At the **Saline Recirculation** step, do the following:

## Instructions

1. To disconnect the patient and prepare for saline recirculation, follow the onscreen instructions, and then confirm all preparation steps are complete.



### NOTE!

Following the blood return, the saline bag fluid is discolored but remains sterile.

2. Start saline recirculation.  
Recirculation time remaining is displayed.
3. Tap the blood flow rate icon to adjust Blood Flow Rate (BFR) or change a bag.
4. Press the **Stop** button. To continue treatment, tap **Reconnect Patient**. To end treatment, tap **Discard Set**.

Some alarms are disabled during recirculation because the system is no longer attached to the patient.

## Prime (flush)

### Before you start

At the **Prime** step, do the following:

### Instructions

1. To prepare to flush the set, follow the onscreen instructions:
  - 1.1 Hang a 1-liter bag of priming solution.
  - 1.2 Clamp the lines identified on the screen.
  - 1.3 Connect the access and return lines as instructed on the screen.
  - 1.4 Unclamp the lines, as shown.
  - 1.5 Confirm that all preparation steps are complete.
2. To begin the flush, tap the **Prime** button.  
The screen shows the progress of the flush.

## Reconnect patient

### Before you start

On the Reconnect Patient screen, do the following:

### Instructions

1. To rearrange the lines and connect to the patient, follow the onscreen instructions, and then confirm all steps are complete.
2. To change bag or syringe, tap the **Change bag** button, and select the required item.
3. When all reconnection steps are confirmed, tap the **Start Treatment** button to resume treatment.

## Manually terminating a treatment

### About manually terminating a treatment

This section describes how to terminate a patient treatment manually at any time in the event of certain alarms, power failure, or other emergency. The operator can perform a manual termination ("Manually terminating a treatment (CRRT set shown)", page 87) with blood return (see "Manual termination with blood return", page 88) or without blood return (see "Manual termination without blood return", page 89).

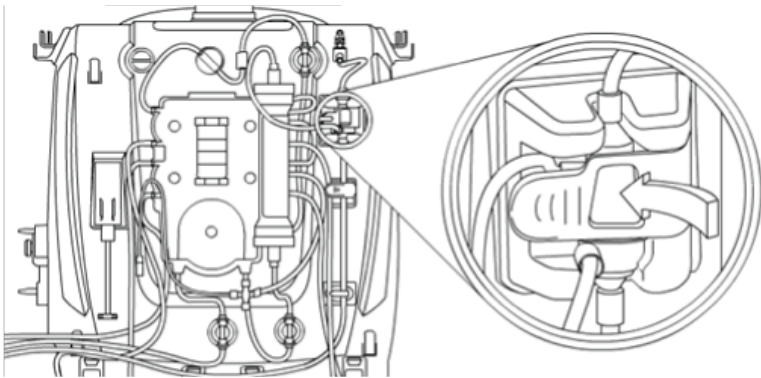

Figure **Manually terminating a treatment (CRRT set shown)**

1. To return blood, connect saline to the access line, monitor deaeration chamber fluid level, and inspect return line for air infusion.
2. To return the blood, use the pump crank stored on the back panel of the control unit.

The crank can only turn the blood pump clockwise.



**WARNING!**

Continually monitor the blood return operation. If clotting or poor return operation is seen, discontinue blood return and end treatment.

3. To remove set, compress loader clips to release set, then pull set to disengage from pinch valves and pump rotors.

To turn the pump rotors manually, use the screwdriver tool built into the pump crank. Tug to remove pump segments manually.

## Manual termination with blood return

### Before you start



**WARNING!**

Air detection and disconnection alarms are disabled during manual blood return when using the hand crank. Observe the return line carefully for air until manual return is complete and the patient is disconnected.



**NOTE!**

This procedure may require a sterile spike connector to connect to the sterile saline bag. Any remaining solutions can be used with a new set as needed.

### Instructions

1. Turn the control unit off.
2. Clamp the access line, red-striped, and disconnect from the patient. Attach the access line to a 1-liter bag of sterile saline, using a sterile spike connector if needed. Unclamp the access line.
3. Press and hold the Return Clamp button on the right side of return line clamp assembly, and remove the return line, blue-striped, from the return line clamp.

4. Observe the fluid level in the deaeration chamber. If the level is too low, remove excess air through the chamber monitor line by doing the following:
  - 4.1 Clamp the chamber monitor line, and disconnect the line from the return pressure port.
  - 4.2 To allow blood to fill the deaeration chamber to the correct fluid level, open and close the clamp.
5. If no return pressure is available, attach a 50-ml luer-lock sterile syringe, without needle, to the distal end of the chamber monitor line. Aspirate air/blood until the deaeration chamber fluid level is at the correct level. When the level has been adjusted by using the syringe, clamp the monitor line.
6. Remove the pump crank from its holder on the rear panel. To return blood to the patient, insert the crank into the blood pump rotor, and turn clockwise.
7. Clamp the return line, blue-stripped, and disconnect it from the patient. Clamp lines to all bags.
8. To release the disposable set, press the carrier clips.
9. Pull the recessed screw driver from the pump crank, and starting with any peristaltic pump, insert the screw driver into the rotor. Turn each pump counter clockwise. To remove the pump segment from the pump raceway, turn the rotor a few times. To remove the segment, it may be necessary to gently tug on the set while turning the pump.
10. To adjust the pinch valves to their neutral positions when the pump segments are free, use the crank, then pull the set to disengage the lines.
11. Discard the set.

### Manual termination without blood return

#### **Before you start**

Blood contained in the blood flow path is lost during manual termination without blood return. For the exact blood volume, see the disposable set instructions.

## **Instructions**

1. Turn the control unit off.
2. Clamp the return line, blue-striped, and access line, red-striped, and disconnect them from the patient. Clamp lines to all bags.
3. To release the disposable set, press the carrier clips.
4. Pull the recessed screw driver from the pump crank, and starting with any peristaltic pump, insert the screw driver into the rotor. Turn each pump counter clockwise. To remove the pump segment from the pump raceway, turn the rotor a few times. To remove the segment, it may be necessary to gently tug on the set while turning the pump.
5. To adjust the pinch valves to their neutral positions when the pump segments are free, use the crank, then pull the set to disengage the lines.
6. Discard the set.

## Chapter 3

# Alarms and troubleshooting

## **Alarms** **93**

---

Alarm safety and monitoring systems ... 93

PrisMax system alarms ... 94

Primary alarms ... 101

Setup alarms ... 135

Malfunction alarms ... 152

Alarm off/override alarms ... 154

Multiple alarm management ... 161

Events ... 162

## **Troubleshooting** **163**

---

About troubleshooting ... 163

Miscellaneous troubleshooting ... 163

Power failure ... 166

Fluid leakage ... 167

Air removal ... 168

Use with cardiac monitor ... 169



# Alarms and troubleshooting

## Alarms

### Alarm safety and monitoring systems

The **PrisMax** is continually monitoring the state of the device and the therapy. If this monitoring encounters an unexpected condition, an alarm may be raised. This alarm has a defined priority, system reaction, and notification to the operator. This notification to the operator can include the following:

- The status light turns red or yellow
- An audible alarm sounds
- An onscreen alarm message showing a prioritized list of corrective actions to mitigate the alarm if possible

Specific monitoring includes the following:

- Pressure: The integral pressure monitoring system detects abnormal pressure conditions that could occur in case of occlusions, disconnections, or clotting. Software also verifies pressures fluctuate slightly within their normal ranges, indicating normal pump operation.
- Blood leak detection: Self-testing periodically tests the blood leak detector. If blood is present in the effluent line, an alarm occurs and the fluid pumps stop.
- The ultrasonic air bubble detector continually monitors the return line for air. If the air bubble detector detects air, an alarm occurs, the blood pump stops, and the return line clamp closes.
- Scales continually monitor pumped volume and weight and flow rates of the PBP, dialysate, replacement, and effluent pumps. Each scale includes two separate independent measurement devices, which are continuously monitored to ensure both weight measurements are the same.
- The drip tray at the base of the control unit collects fluid. An alarm occurs if fluid accumulates past 50 ml.



**NOTE!**

Do not place any items in the drip tray. This could delay detection of a fluid leak and interfere with the weight readings of the bags.

- If the **PrisMax** detects a component failure, the system enters a safe state and a Call Service alarm occurs.

## PrisMax system alarms

### About PrisMax system alarms



**WARNING!**

When responding to any alarm, carefully follow the onscreen instructions.



**WARNING!**

Do not continue operation if the same alarm occurs repeatedly. End treatment and contact service.



**WARNING!**

Renormalize the Blood Leak Detector (BLD) if the effluent line is removed and then reinserted into the Blood Leak Detector (BLD) during treatment.

**WARNING!**

The Responsible Organization must compare and evaluate the sound level of the **PrisMax** control unit with the surrounding sound levels in the facility, and when different alarm presets are used for different control units in any single area. The Responsible Organization must ensure that the control unit's alarm sound can be recognized when an alarm is present.

**WARNING!**

Continuing to clear alarms without addressing the underlying problem may lead to errors in patient fluid balance leading to termination of treatment, inability to detect return disconnect, inability to detect blood leak in the effluent, inability to detect fluid leaks in the base detector.

**CAUTION!**

Tapping the **Alarm Off**, **Disable**, or **Override** buttons decreases the sensitivity of the alarm system.

**NOTE!**

To avoid fluid balance errors, always identify and resolve the cause of a solution scale weight alarm before continuing treatment. If another weight scale alarm occurs and its cause cannot be identified, consult a physician and discontinue the treatment as required.

### Alarm priorities

Alarms are organized by priority and the screen displays the highest-priority alarm. Once the highest-priority alarm is corrected, the next highest-priority alarm (if any) is displayed. As each alarm appears on the display, follow the onscreen instructions. If multiple alarms of the same priority are displayed, the alarms of the same priority will be displayed in chronological order. It is possible to dock an alarm, sending the alarm to the background for 2 minutes while dealing with other alarms or correcting the underlying cause of the alarm.

**NOTE!**

If more than one alarm is active simultaneously, the alarm windows provides the **More Alarms** button which displays a list of the active alarms where the operator can select which alarm is currently displayed.

If an alarm cannot be corrected:

1. Check patient
2. Stop treatment and return blood if possible, and per hospital/clinic policy
3. Contact service

| Priority    | Indicators   |
|-------------|--|
| High        | <p>Flashing red status light</p> <p>High-priority audio alarm</p> <p>Alarm message displayed in red pop-up window</p>  |
| Medium      | <p>Flashing yellow status light</p> <p>Medium-priority audio alarm</p> <p>Alarm message displayed in yellow pop-up window</p>  |
| Low         | <p>Yellow status light (non-flashing)</p> <p>Low-priority audio alarm</p> <p>Alarm message displayed in yellow pop-up window</p>   |
| Information | <p>Green status light (non-flashing)</p> <p>Info alarms sound single 'beep' every five minutes</p> <p>Information message may appear in a gray pop-up window or as an advisory in the message center</p> |

| Priority  | Indicators  |
|---|---|
| Malfunction alarm   | Flashing red status light<br><br>Malfunction audio alarm<br><br>Call Service message displayed in red pop-up window |
| Sound pressure levels: The default setting for the alarm sound is 65 dB(A). The maximum sound level is 70 dB(A). Use the System Configuration function to adjust alarms sound levels. The minimum sound pressure level is 45 dB(A). |   |

See "Alarm notification", page 315, of this manual for IEC 60601-1-8 alarm priority definitions.

### High-priority

High-priority alarms indicate a possible patient hazard that requires immediate operator intervention. Air bubbles in the return line or persistent extreme positive return pressure are examples of high-priority alarm conditions.

The **PrisMax** responds to a high-priority alarm by displaying instructions for responding to the alarm and entering a safe state, including stopping the blood pump, stopping the fluid pumps, stopping the syringe pump or closing the return line clamp depending on the alarm. When the alarm is resolved, the alarm message disappears, the status light turns green, and blood and solution pumps restart within a few seconds.

### Medium-Priority

Medium-priority alarms indicate a possible patient hazard that is not immediate. An empty solution bag or full effluent bag are examples of medium-priority alarm conditions.

The **PrisMax** responds to a medium-priority alarm by displaying instructions for responding to the alarm and entering a safe state. Automatic system reactions to these alarms can include stopping the blood pump, stopping the fluid pumps, stopping the syringe pump or closing the return line clamp depending on the alarm. When the alarm is resolved, the alarm message disappears, the status light turns green, the solution pumps restart within a few seconds.

### Low-Priority

Low-priority alarms indicate a condition that the operator should be aware of, but does not pose an immediate risk to the patient. Treatment

continues during a low-priority alarm with some exceptions. Details can be found in the alarm descriptions.

When a low-priority alarm is resolved, the alarm message disappears and the status light turns green.

### **Information**

Information messages provide useful information, and indicate non-alarm conditions that do not interrupt treatment. Information messages are frequently displayed during prime or recirculation, when a patient is not connected to the system.

### **Malfunction**

Some alarms allow retries to get past the incorrect operation. Malfunction alarms indicate that patient safety cannot be monitored due to a system failure. Examples of malfunction alarms include self test failures, failure of software to complete tasks within a specified time, or a hardware failure.

Some malfunction alarms can be resolved by retesting the failure, while others require service. The **PrisMax** responds to a malfunction alarm by displaying instructions for responding to the alarm. Malfunction alarms are high-priority alarms.

## **Alarm message**

The **PrisMax** system continually monitors the control unit and the disposable set for normal operation. If an abnormal situation is detected, an alarm occurs.

When an alarm occurs, follow the onscreen instructions to correct the alarm condition ("Example alarm message", page 99). If the operator cannot correct the alarm, contact an authorized service technician.

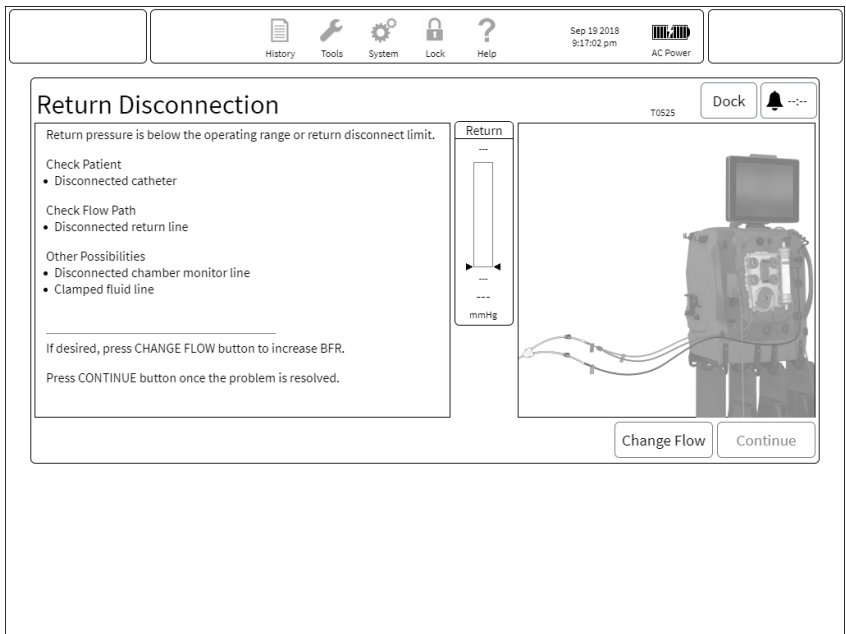

Figure Example alarm message

1. Symbol indicates that an active alarm window is minimized.
2. Symbol indicates that an alarm is overridden.
3. Name of alarm.
4. Code identifies alarm for technical reference. Use this code to find alarm information or when communicating with your local Baxter representative.
5. Tap the **Dock** button to minimize the alarm window and return to the previous screen. If an active alarm window is minimized, an alarm icon appears in the toolbar and the alarm is silenced for up to 2 minutes.
6. Tap to silence the alarm for 2 minutes, or until another alarm occurs. When alarm silence is active, this button shows a countdown of the silence time remaining.
7. Description of alarm and corrective actions.
8. Real-time pressure display, for pressure-related alarms.
9. Illustration shows information related to the alarm. Arrows or lines highlight the relevant component.
10. Depending on alarm, tap button(s) to perform a corrective action, continue operation, or override the alarm.

### Typical alarm screens

See "Air Detected In Blood Alarm", page 100, and "Flow Problem Alarm", page 100, that show examples of typical alarm screens.

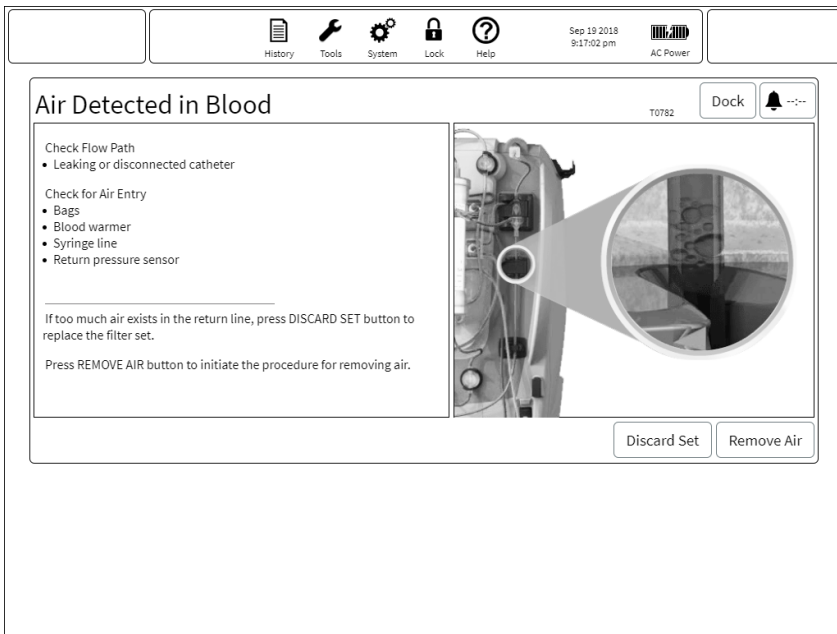

Figure Air Detected in Blood Alarm

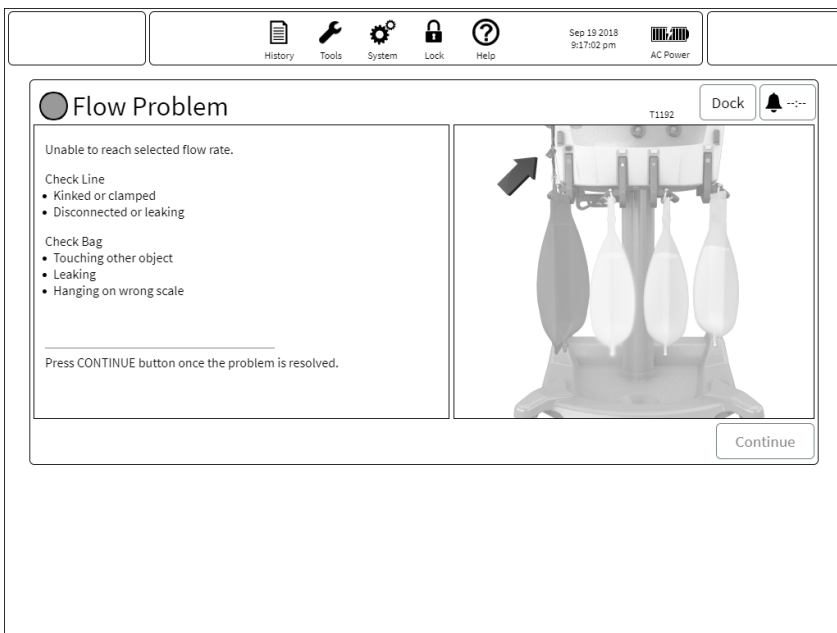

Figure Flow Problem Alarm

# Primary alarms

## About primary alarms

Primary alarms are alarms or notifications that require user intervention and are associated with risk to the patient or user.

## High-priority alarms

Table **General alarms**

| Alarm - Code(s)                   | Possible causes  | Corrective actions  |
|-----------------------------------|--|---|
| Access Extremely Negative - T0775 | Patient is moving, coughing, or being suctioned                        | Flush or reposition the catheter according to hospital protocol.  |
|                                   | Blocked or clotted catheter  | Correct kinked or clamped lines.  |
|                                   | Clamped or kinked access line  | Consider decreasing Blood Flow Rate (BFR).  |
|                                   | Too high Blood Flow Rate   | Tap the <b>Continue</b> button to resume operation (button is active when access pressure is within normal limits).   |
| Access Extremely Positive - T1237 | Blood Flow Rate is too low   | Correct kinked or clamped lines.  |
|                                   | External device (if in use) is delivering blood at a too high pressure | Consider increasing Blood Flow Rate (BFR) to reduce access pressure.<br><br>Tap the <b>Continue</b> button to resume operation (button is active when access pressure is within normal limits). |

| Alarm - Code(s)                    | Possible causes  | Corrective actions  |
|------------------------------------|--|---|
| Air Detected in Blood - T0792      | <p>Leaking or disconnected catheter</p> <p>Air entry from a bag, blood warmer, syringe line, access or PBP lines</p> <p>Set not fully primed</p> | <p>Reposition the catheter according to hospital protocol.</p> <p>Inspect the entire set for leaks or disconnections.</p> <p>Tap the <b>Remove Air</b> button and follow the onscreen instructions for air removal.</p> <p>If air is present in the entire return line, tap the <b>Discard Set</b> button and change the set.</p> |
| Anti-coagulation Suspended - T2228 | <p>Anticoagulation not performed for over 6 minutes</p> <p>Existing Alarms</p>   | <p>Dock Alarm and clear existing alarms.</p> <p>Dock Alarm and complete bag change.</p> <p>Once the <b>Continue</b> button is active, tap <b>Continue</b>.</p>  |
| Change Set - T0948                 | <p>Blood pump stopped for over 10 minutes, set must be changed.</p> <p>Stop button pressed</p> <p>Unresolved alarm condition</p>                 | <p>Tap the <b>Discard Set</b> button and change the set.</p>  |
| Deaeration Chamber Missing - T1043 | <p>No deaeration chamber detected</p> <p>Chamber missing</p> <p>Chamber incorrectly installed</p>  | <p>Verify that deaeration chamber is correctly installed in the holder, and that the holder is closed.</p>  |

| Alarm - Code(s)                        | Possible causes  | Corrective actions   |
|--|--|--|
| Effluent Bag Weight Change - T1721     | <p>Unexpected weight increase detected on the scale</p> <p>Bag in motion</p> <p>Bag contact with foreign object</p> <p>Scale contact with foreign object</p> | <p>Check scale for obstructions or the bag moving.</p> <p>Tap the <b>Continue</b> button to resume operation.</p>  |
| Effluent Drain Weight Increase - T1716 | <p>Unexpected weight increase detected on the scale</p> <p>Bag in motion</p> <p>Bag contact with foreign object</p> <p>Scale contact</p>                     | <p>Check scale for obstructions or the bag moving.</p> <p>Tap the <b>Continue</b> button to resume operation.</p>  |
| High Filter Pressure - T0781           | <p>High filter pressure detected</p> <p>Clamped or kinked line</p> <p>Clot at the filter inlet</p> <p>Too high Blood Flow Rate (BFR)</p>                     | <p>Correct kinked or clamped lines.</p> <p>Consider decreasing Blood Flow Rate (BFR) to reduce filter pressure.</p> <p>Tap the <b>Continue</b> button to resume operation (button is active when filter pressure is within normal limits).</p> <p>Monitor clotting parameters.</p> |
| No Line in Air Detector - T1045        | <p>Return line not in Air Bubble Detector (ABD).<br/>Line incorrectly installed.</p> <p>Air Bubble Detector (ABD) door not completely closed.</p>            | <p>Open Air Bubble Detector (ABD) door, verify that the return line is correctly installed in the tubing guides, then close and latch the door.</p>  |

| Alarm - Code(s)                                | Possible causes  | Corrective actions   |
|--|--|--|
| Pod<br>Repositioning<br>Interrupted -<br>T1632 | Clamped lines  | <p>Check for clamped access lines</p> <p>Tap the <b>Continue</b> button to retest pressure.</p> <p>Tap the <b>Discard Set</b> button and change set.</p>   |
| Pod<br>Repositioning<br>Interrupted -<br>T1633 | Clamped lines  | <p>Check for clamped access and return lines</p> <p>Tap the <b>Continue</b> button to retest pressure.</p> <p>Tap the <b>Discard Set</b> button and change set.</p>  |
| Return Barrier<br>May Be Wet -<br>T1277, T1630 | Return chamber monitor line may be wet                                 | <p>If fluid barrier is wet, tap the <b>Discard Set</b> button and change set.</p> <p>Tap the <b>Open Clamp</b> button to equalize the pressure in the circuit set.</p> <p>Tap the <b>Continue</b> button to retest the fluid barrier.</p>          |
| Return Clamp Not<br>Closed - T1659             | <p>Return clamp fails to close</p> <p>Debris blocking return clamp</p> | <p>Follow the onscreen instructions to clamp the patient, and verify that the blue line is correctly installed in the return clamp.</p> <p>Once the <b>Continue</b> button is active, unclamp the patient connections and tap <b>Continue</b>.</p> |
| Return Clamp Not<br>Opened - T1182             | Obstruction prevents clamp from opening                                | <p>Remove any obstruction that prevents the clamp from opening.</p> <p>Tap the <b>Continue</b> button to clear the alarm and return to normal operations.</p>  |

| Alarm - Code(s)                            | Possible causes                                      | Corrective actions  |
|--|--|---|
| Return Disconnection - T0525, T1168, T1169 | Patient moved or catheter has become dislodged       | Check that the patient catheter, return line, and chamber monitor line are properly connected.                      |
|  | Disconnected return line                             | Correct kinked or clamped lines.  |
|  | Disconnected chamber monitor line                    | Consider increasing blood flow rate (BFR).  |
|  | Clamped fluid line                                   | Tap the <b>Continue</b> button to resume operation.   |
|  | Wet fluid barrier                                    |   |
|  | Blood flow path obstructed before deaeration chamber |   |
|  | Return pressure sensor failed                        |   |
| Return Extremely Negative - T1656          | Return pressure is out of range                      | Verify that priming bag is not empty.   |
|  | Low blood flow                                       | Verify that lines are not clamped.  |
|  |  | Tap the <b>Continue</b> button to clear the alarm and return to normal operations.                                  |
| Return Extremely Positive - T0526          | Patient is moving, coughing, or being suctioned      | Flush or reposition the catheter according to hospital protocol.  |
|  | Blocked or clotted catheter                          | Correct kinked or clamped lines.  |
|  | Clamped or kinked return line                        | Consider decreasing Blood Flow Rate (BFR).  |
|  | Blood Flow Rate too high                             | Tap the <b>Open Clamp</b> button to relieve pressure in the return line.  |
|  | Return pressure sensor failed                        | Tap the <b>Continue</b> button to resume operation (button is active when return pressure is within normal limits). |

| Alarm - Code(s)                    | Possible causes   | Corrective actions   |
|------------------------------------|---|--|
| Return Line Not in Clamp - T0793   | Return line not in clamp<br>Line incorrectly installed  | Reinstall the return line in the clamp.<br><br>Tap the <b>Open Clamp</b> button to allow the tube to be re-inserted.   |
| Return Sensor Disconnected - T1167 | Tip or threads of return monitor line damaged<br><br>Tip of monitor line incorrectly installed  | If monitor tip is damaged, tap the <b>Discard Set</b> button and change set.<br><br>Follow the onscreen instructions to connect the return monitor line. Tap the <b>Continue</b> button to retest the fluid barrier. |
| Set Disconnection - T0777          | Disconnection anywhere in set (return line, internal lines)<br><br>Line between blood pump and filter pod is obstructed<br><br>Blood flow rate too low<br><br>Filter pressure sensor failed<br><br>Return pressure disconnection and failure of return pressure alarm | Ensure that there are no leaks or disconnections, tap the <b>Continue</b> button.<br><br>Tap the <b>Discard Set</b> button and change the set  |
| Total Loss of Power - T0595        | Battery voltage drops below 21.5 V, system not connected to AC power  | Connect system to AC power and reset the system.   |

Table TherMax alarms

| Alarm - Code(s)                                | Possible causes   | Corrective actions  |
|--|---|---|
| Call Service - T2259                           | <b>TherMax</b> not properly installed   | Tap the <b>Discard Set</b> button and change the set.<br><br>Call Service to configure <b>TherMax</b> .   |
| <b>TherMax</b> Cover Open - T2307              | <b>TherMax</b> is open in the cleaning position<br><br>Top cover latches are not fully closed | Close latches. If unable to close latches discontinue therapy.<br><br>Tap the <b>Discard Set</b> button and change the set.   |
| <b>TherMax</b> Disposable Leak - T2285         | Leak from the blood warmer disposable   | Tap the <b>Discard Set</b> button and change the set.<br><br>Discontinue therapy and follow hospital protocol.  |
| <b>TherMax</b> Disposable Not Inserted - T2284 | Warmer disposable not detected during therapy   | Confirm that the warmer disposable is pushed in all the way.<br><br>Tap the <b>Discard Set</b> button and change the set.<br><br>Discontinue therapy if this can not be resolved. |
| <b>TherMax</b> In Transport Position - T2274   | Warmer arm is in the transportation position  | Adjust the warmer to the operating position.<br><br>Tap the <b>Discard Set</b> button and change the set.   |
| <b>TherMax</b> Malfunction - T2254             | Disconnected cable between <b>TherMax</b> and <b>PrisMax</b>                                  | Confirm the serial cable is connected between systems.<br><br>Tap the <b>Discard Set</b> button and change the set.   |

## Medium-priority alarms

Table **General alarms**

| Alarm - Code(s)                             | Possible causes   | Corrective actions  |
|---|---|---|
| Access Line Clamped - T1615                 | Problem with patient connection lines                               | Unclamp the access or return lines, or both.  |
|   | Line clamped or kinked  | Check line connections.   |
|   | Crossed lines   | Confirm that bags are not partially supported.<br><br>Tap the <b>Continue</b> button to retest.                         |
| Access Pod Not Attached - T1597             | Debris in pod socket. Damaged pod. Pod incorrectly installed.       | Clean any debris from pod socket.   |
|   |   | Make sure that pod is correctly installed.<br><br>Tap the <b>Continue</b> button to retest pod presence.                |
|   |   | If pod is damaged, tap the <b>Discard Set</b> button and change set.<br><br>Perform a self test after pod installation. |
| Auto Effluent Circuit Loader Failed - T1138 | Tubes interfering with plastic cassette                             | Tap the <b>Discard Set</b> button to replace filter set.  |
|   | Pinch valves engaged  | Tap the <b>Continue</b> button once the problem is resolved.  |
|   | Obstructions  |   |
| Auto Effluent Max Set Life Reached - T2119  | Set in use longer than intended life                                | Tap the <b>Discard Set</b> button and change the set.   |
|   | Therapy has been performed longer than the intended life of the set | Tap the <b>Alarm Off</b> button to continue treatment with the current set.   |

| Alarm - Code(s)                     | Possible causes  | Corrective actions   |
|-------------------------------------|--|--|
| Battery Temperature Problem - T1055 | Battery temperature too high   | <p>Turn off the control unit.</p> <p>Allow the control unit to acclimate to the ambient temperature for at least one hour.</p> <p>Tap the <b>Alarm Off</b> button to temporarily override the alarm.</p>   |
| Blood Leak Detected - T0830         | <p>The Blood Leak Detector (BLD) detects blood in the effluent line, which can indicate a ruptured filter membrane.</p> <p>Leak in filter membrane</p> <p>Tubing incorrectly installed in the Blood Leak Detector (BLD)</p> <p>Tubing is cloudy or debris in the tubing path</p> <p>Air in the effluent line</p> <p>The wrong section of tubing is installed in the Blood Leak Detector (BLD).</p> <p>Dirty Blood Leak Detector (BLD) optics.</p> <p>TPE: Formed elements of lipids in plasma discolored plasma.</p> | <p>Check for air bubbles in effluent line in the Blood Leak Detector (BLD).</p> <p>Tap the <b>Alarm Off</b> button to dislodge bubble.</p> <p>If air bubbles recur, check for kinked effluent line, or decrease Blood Flow Rate (BFR).</p> <p>Verify that effluent line is correctly installed in the Blood Leak Detector (BLD).</p> <p>Check for liquid or debris in the Blood Leak Detector (BLD) tubing path and effluent line: clean with a lint-free cloth, then dry thoroughly.</p> <p>If blood is in the effluent line, change the set. Send sample of effluent to the blood lab for cell count.</p> <p>Tap the <b>Discard Set</b> button and change the set.</p> <p>Tap the <b>Continue</b> button to clear the alarm and return to normal operations.</p> |

| Alarm - Code(s)                   | Possible causes   | Corrective actions   |
|-----------------------------------|---|--|
| Cannot Monitor Return - T0527     | Disconnected patient catheter                             | Check that the patient catheter, return line, and chamber monitor line are properly connected.   |
|                                   | Disconnected return line                                  | Correct kinked or clamped lines.   |
|                                   | Blood flow path obstruction before the deaeration chamber | Tap the <b>Accept</b> button to continue operation for 2 minutes.  |
|                                   | Disconnected chamber monitor line                         | Consider increasing Blood Flow Rate (BFR).   |
|                                   | Clamped fluid line  |  |
| Check Access - T1145              | Access pressure operating point is undetectable           | Alarm automatically clears if access pressure operating point is set to a detectable level.  |
|                                   | Patient is moving, coughing, or being suctioned           | Flush or reposition the catheter according to hospital protocol.<br><br>Correct kinked or clamped lines.                                   |
|                                   | Blocked or clotted catheter                               | Consider increasing Blood Flow Rate (BFR).   |
|                                   | Clamped or kinked access line                             | Tap the <b>Alarm Off</b> button to continue operation with the current access pressure operating point.                                    |
|                                   | Too low blood flow rate                                   |  |
| Check Syringe Line - T0586, T0587 | Syringe force higher than expected.                       | Correct kinked or clamped syringe line.  |
|                                   | Clamped or kinked line.                                   | Verify that the correct syringe brand is installed properly, with the plunger locked.  |
|                                   | Syringe improperly installed.                             | Tap the <b>Continue</b> button to resume operation.  |
|                                   | Wrong syringe brand                                       | If alarm recurs or syringe, line, or plunger cannot be correctly installed, tap the <b>Change Syringe</b> button to install a new syringe. |

| Alarm - Code(s)                      | Possible causes   | Corrective actions   |
|--------------------------------------|---|--|
| CRRT Gain/Loss Limit Reached - T0798 | Fluid gain/loss for the CRRT set over the last 180 minutes exceeds the setting.   | Tap the <b>Discard Set</b> button and end the therapy.   |
| CRRT Max Set Life Reached - T1262    | Set in use longer than intended life<br><br>Therapy has been performed longer than the intended life of the set   | Tap the <b>Discard Set</b> button and change the set.<br><br>Tap the <b>Alarm Off</b> button to continue treatment with the current set.   |
| Dia Weight Increase - T1719          | Unexpected weight increase detected on the scale<br><br>Bag in motion<br><br>Bag contact with foreign object<br><br>Scale contact with foreign object             | Check scale for obstructions or the bag moving.<br><br>Tap the <b>Continue</b> button to resume operation.   |
| Dialysate Bag Not Mixed - T1203      | The solution flow rate and weight indicate that a double- compartment bag is not mixed correctly.<br><br>The seal between the two bag compartments is not broken. | Consult physician.<br><br>Do not continue using the bag.<br><br>Tap the <b>Change Bag</b> button to open the bag change dialog window and begin a bag change operation on this scale.<br><br>Follow onscreen instructions to change bag. |

| Alarm - Code(s)                   | Possible causes  | Corrective actions  |
|-----------------------------------|--|---|
| Effluent Pod Not Attached - T1598 | Debris in pod socket.<br>Damaged pod. Pod incorrectly installed.   | <p>Clean any debris from pod socket.</p> <p>Make sure that pod is correctly installed.</p> <p>Tap the <b>Continue</b> button to retest pod presence.</p> <p>If pod is damaged, tap the <b>Discard Set</b> button and change set.</p> <p>Perform a self test after pod installation.</p> |
| Filter Pod Not Attached - T1599   | Debris in pod socket.<br>Damaged pod. Pod incorrectly installed.   | <p>Clean any debris from pod socket.</p> <p>Make sure that pod is correctly installed.</p> <p>Tap the <b>Continue</b> button to retest pod presence.</p> <p>If pod is damaged, tap the <b>Discard Set</b> button and change set.</p> <p>Perform a self test after pod installation.</p> |
| Flow Problem - T0822              | <p>The effluent bag weight varies from the expected weight.</p> <p>Yellow effluent line is kinked, clamped, or connected to the wrong bag.</p> <p>Effluent bag is touching another object, leaking, or hanging on the wrong scale.</p> | <p>Correct kinked or clamped lines.</p> <p>Verify line connections.</p> <p>Remove any object touching the bag.</p> <p>Check the bag for leaks.</p> <p>Verify that bag is hanging on correct scale.</p> <p>Tap the <b>Continue</b> button to resume operation.</p>                       |

| Alarm - Code(s)  | Possible causes  | Corrective actions   |
|--|--|--|
| Flow Problem -<br>T0823, T0824,<br>T0935, 1069,<br>T1070 | The solution bag weight varies from the expected weight.<br><br>Kinked or clamped lines<br><br>Disconnected or leaking connections<br><br>Line connected to incorrect bag<br><br>Line touching another object<br><br>Leaking bag<br><br>Bag hanging on wrong scale |  <p><b>NOTE!</b><br/>Alarm detection delayed for up to 40 seconds.</p> Correct kinked or clamped lines.<br><br>Verify line connections.<br><br>Remove any object touching the bag.<br><br>Check the bag for leaks.<br><br>Verify that bag is hanging on correct scale.<br><br>Tap the <b>Continue</b> button to resume operation.                 |
| Membrane Pressure Excessive -<br>T0938                   | Filter shows signs of clotting<br><br>Clots have formed in the filter<br><br>Clamped lines in the blood flow path<br><br>High Rep, PBP, or PFR rate<br><br>Inadequate anticoagulation<br><br>Pressure measurement failure  | Correct kinked or clamped lines.<br><br>Decrease Rep, PBP, PFR rates as needed.<br><br>Tap the <b>Tools</b> button, then select <b>Initiate Self-Test</b> to reposition the pressure pod membrane.<br><br>Assess anticoagulation requirements according to hospital policy.<br><br>Tap the <b>Discard Set</b> button and change the set.<br><br>Tap the <b>Continue</b> button to clear the alarm and return to normal operations. |

| Alarm - Code(s)                      | Possible causes   | Corrective actions  |
|--------------------------------------|---|---|
| <p>Normalization Failure - T0853</p> | <p>Blood Leak Detector (BLD) normalization failure during therapy.</p> <p>Tubing incorrectly installed in the Blood Leak Detector (BLD).</p> <p>Tubing is cloudy or debris in the tubing path.</p> <p>Air in the effluent line. The wrong section of tubing is installed in the Blood Leak Detector (BLD).</p> <p>Dirty Blood Leak Detector (BLD) optics. Blood present in the effluent line.</p> | <p>Verify that effluent line is correctly installed in the Blood Leak Detector (BLD).</p> <p>Remove air bubbles in effluent line.</p> <p>Slide the tube inside the blood leak detector (BLD) to increase detection signal.</p> <p>If displayed transmissivity (detection signal) &gt; 85%, tap the <b>Continue</b> button to retry.</p> <p>If displayed transmissivity (detection signal) &lt; 85%, change the set.</p> <p>Tap the <b>Alarm Off</b> button to override detection of this alarm.</p> <p>Tap the <b>Discard Set</b> button and change the set.</p> <p>Tap the <b>Continue</b> button to clear the alarm and return to normal operations</p> |
| <p>Patient High Voltage - T1275</p>  | <p>Discharger switch is open</p> <p>Patient connected to mains (AC) power</p> <p>External defibrillator used</p>  | <p>Do not touch the patient.</p> <p>Verify the patient is not connected to mains voltage.</p> <p>Tap the <b>Retest</b> button to reset the discharge switch.</p>  |

| Alarm - Code(s)                       | Possible causes  | Corrective actions  |
|---------------------------------------|--|---|
| PBP Bag Not Mixed - T0825             | <p>The solution flow rate and weight indicate that a double- compartment bag is not mixed correctly.</p> <p>The seal between the two bag compartments is not broken.</p> | <p> <b>NOTE!</b><br/>Alarm detection delayed for up to 40 seconds.</p> <p>Consult physician.</p> <p>Do not continue using the bag.</p> <p>Tap the <b>Change Bag</b> button to open the bag change dialog window and begin a bag change operation on this scale.</p> <p>Follow onscreen instructions to change bag.</p> |
| PBP Weight Change - T1720             | <p>Unexpected weight increase detected on the scale</p> <p>Bag in motion</p> <p>Bag contact with foreign object</p> <p>Scale contact with foreign object</p>             | <p>Check scale for obstructions or the bag moving.</p> <p>Tap the <b>Continue</b> button to resume operation.</p>   |
| Pod Repositioning Interrupted - T1631 | Clamped lines  | <p>Check for clamped lines</p> <p>Tap the <b>Continue</b> button to retest pressure.</p> <p>Tap the <b>Discard Set</b> button and change set.</p>   |
| Rep Weight Increase - T1717           | <p>Unexpected weight increase detected on the scale</p> <p>Bag in motion</p> <p>Bag contact with foreign object</p> <p>Scale contact with foreign object</p>             | <p>Check scale for obstructions or the bag moving.</p> <p>Tap the <b>Continue</b> button to resume operation.</p>   |

| Alarm - Code(s)                             | Possible causes  | Corrective actions  |
|---|--|---|
| Rep2 Weight Increase - T1718                | <p>Unexpected weight increase detected on the scale</p> <p>Bag in motion</p> <p>Bag contact with foreign object</p> <p>Scale contact with foreign object</p>             | <p>Check scale for obstructions or the bag moving.</p> <p>Tap the <b>Continue</b> button to resume operation.</p>   |
| Replacement 2 Bag Not Mixed - T1201         | <p>The solution flow rate and weight indicate that a double- compartment bag is not mixed correctly.</p> <p>The seal between the two bag compartments is not broken.</p> | <p>Consult physician.</p> <p>Do not continue using the bag.</p> <p>Tap the <b>Change Bag</b> button to open the bag change dialog window and begin a bag change operation on this scale.</p> <p>Follow onscreen instructions to change bag.</p> |
| Replacement Bag/Container Not Mixed - T1202 | <p>The solution flow rate and weight indicate that a double- compartment bag is not mixed correctly.</p> <p>The seal between the two bag compartments is not broken.</p> | <p>Consult physician.</p> <p>Do not continue using the bag.</p> <p>Tap the <b>Change Bag</b> button to open the bag change dialog window and begin a bag change operation on this scale.</p> <p>Follow onscreen instructions to change bag.</p> |
| Return Clamp Not Closed - T0603             | Obstruction prevents clamp from closing  | Remove any obstruction that prevents the clamp from closing.  |
| Return Line Clamped - T1614                 | <p>Problem with patient connection lines</p> <p>Line clamped or kinked</p> <p>Crossed lines</p>  | <p>Unclamp the access or return lines, or both.</p> <p>Check line connections.</p> <p>Confirm that bags are not partially supported.</p> <p>Tap the <b>Continue</b> button to retest.</p>   |

| Alarm - Code(s)                       | Possible causes   | Corrective actions  |
|---------------------------------------|---|---|
| Return Low Operating Point - T1162    | <p>The return operating point is established above -20 mmHg but below the current return disconnect limit.</p> <p>Disconnected patient catheter</p> <p>Disconnected return line</p> <p>Disconnected chamber monitor line</p> <p>Clamped fluid line</p> <p>Catheter size too large or blood flow too low</p> | <p>Check that the patient catheter, return line, and chamber monitor line are properly connected.</p> <p>Correct kinked or clamped lines.</p> <p>Tap the <b>Alarm Off</b> button to decrease the return disconnect limit.</p> <p>Consider increasing Blood Flow Rate (BFR).</p> |
| Scale Calibration Temperature - T1311 | <p>Ambient temperature differs from temperature at time of calibration</p>  | <p>Move the system to a different location.</p> <p>Contact service for recalibration.</p> <p>Tap the <b>Continue</b> button to resume operation.</p>  |

| Alarm - Code(s)                      | Possible causes                               | Corrective actions   |
|--------------------------------------|---|--|
| Syringe Force<br>Overload - T1294    | Syringe force higher than expected.           | Correct kinked or clamped syringe line.  |
|                                      | Clamped or kinked line.                       | Verify that the correct syringe brand is installed properly, with the plunger locked.  |
|                                      | Syringe improperly installed.                 | Tap the <b>Continue</b> button to resume operation.  |
|                                      | Wrong syringe brand                           | If alarm recurs or syringe, line, or plunger cannot be correctly installed, tap the <b>Change Syringe</b> button to install a new syringe. |
| TMP Pressure<br>Excessive -<br>T0782 | High transmembrane pressure (TMP)             | Consider decreasing these flow rates: PFR, Rep, or PBP.  |
|                                      | High Rep, PBP, or PFR flow rate               | Consider increasing Blood Flow Rate (BFR).   |
|                                      | Low blood flow rate (BFR) setting             | Tap the <b>Continue</b> button to resume operation (button is active when TMP is within normal limits).                                    |
|                                      | Inadequate anticoagulation                    | Assess anticoagulation requirements according to hospital policy.  |
|                                      | Wrong filter or effluent pressure measurement |  |

Table TPE alarms

| Alarm - Code(s)                         | Possible causes  | Corrective actions   |
|---|--|--|
| Effluent Excessive Weight Error - T2287 | Bad bag connection   | Check bag connection.  |
|   | Clamped or obstructed line   | Check lines for obstructions.<br><br>Tap the <b>Discard Set</b> button and change the set.   |
| Flow Problem - T2202                    | Estimated solution flow rate is less than half the expected value. |  <b>NOTE!</b><br>Alarm detection delayed for up to 40 seconds.  |
|   | Kinked or clamped lines  |  |
|   | Disconnected or leaking connections                                | Correct kinked or clamped lines.   |
|   | Line connected to incorrect bag                                    | Verify line connections.   |
|   | Line touching other object   | Remove any object touching the bag.  |
|   | Leaking bag  | Check the bag for leaks.   |
|   | Bag hanging on incorrect scale                                     | Verify that bag is hanging on correct scale.<br><br>Tap the <b>Continue</b> button to resume operation.  |
| Membrane Pressure Excessive - T0779     | Clotted filter   | Change filter set.   |
|   | Kinked lines   | Tap the <b>Discard Set</b> button and change the set.<br><br>Unkink lines.<br><br>Increase anticoagulation.<br><br>Decrease Blood Flow Rate (BFR).<br><br>Tap the <b>Continue</b> button to clear the alarm and return to normal operations. |

| Alarm - Code(s)                               | Possible causes                                     | Corrective actions   |
|---|---|--|
| PBP Excessive Weight Error - T2260            | Bad bag connection                                  | Check bag connection.  |
|   | Clamped or obstructed line                          | Check lines for obstructions.<br><br>Tap the <b>Discard Set</b> button and change the set.   |
| PBP Fluid Limit Reached - T0800               | PBP patient fluid input has reached threshold limit | Tap the <b>Alarm Off</b> button to add 200ml to the input threshold.<br><br>Tap the <b>Discard Set</b> button and end the therapy. |
| Replacement Excessive Weight Error - T2286    | Bad bag connection                                  | Check bag connection.  |
|   | Clamped or obstructed line                          | Check lines for obstructions.<br><br>Tap the <b>Discard Set</b> button and change the set.   |
| TMPa Pressure Excessive - T0783               | High transmembrane pressure (TMP)                   | Consider decreasing these flow rates: PPL, Rep, or PBP.  |
|   | High Rep, PBP, or PFR flow rate                     | Consider increasing Blood Flow Rate (BFR).   |
|   | Low blood flow rate (BFR) setting                   | Tap the <b>Continue</b> button to resume operation (button is active when TMP is within normal limits).                            |
|   | Inadequate anticoagulation                          | Assess anticoagulation requirements according to hospital policy.  |
| Wrong filter or effluent pressure measurement | Wrong filter or effluent pressure measurement       | Assess anticoagulation requirements according to hospital policy.  |
|   |   |  |
| TPE Max Set Life Reached - T1268              | Set life usage is exceeded                          | Change the TPE set.  |
|   |   | Tap the <b>Discard Set</b> button and change the set.  |
|   |   | Tap the <b>Alarm Off</b> button to override detection of this alarm.   |

Table TherMax alarms

| Alarm - Code(s)                                 | Possible causes   | Corrective actions   |
|---|---|--|
| <b>TherMax</b><br>Disposable Not Locked - T2296 | Disposable latch on the warmer unit is in the open position                   | Move the latch at the front of the warmer unit to the closed position.   |
| <b>TherMax</b> Leak Detector Error - T2293      | One or both of the <b>TherMax</b> leak detectors have failed their self-test. | Tap the <b>Discard Set</b> button and change the set.  |
| <b>TherMax</b> Not Level - T2302                | Improper warmer installation<br><br>Floor is not level                        | Adjust the position of the <b>PrisMax</b> device until the warmer is horizontal with the floor.<br><br>Tap the <b>Discard Set</b> button and change the set. |

## Low-priority alarms

Table General alarms

| Alarm - Code(s)                        | Possible causes   | Corrective actions  |
|--|---|---|
| Auto-Effluent Bags Full - T0802        | Auto effluent (AE) draining has been paused for too long and the bags are nearly full.                                    | Insert Auto Effluent (AE) drain line in drain, then resume draining.  |
| Bag Empty - T0804, T0805, T0933, T1076 | Bag weight indicates that it is empty<br><br>Bag empty<br><br>Bag partially supported                                     | Follow onscreen instructions to change bag.<br><br>Set solution flow rate to 0 ml/h.<br><br>Remove partial support from bag.                                    |
| Battery Low - T0596                    | System has been on battery for 15 minutes, or battery voltage < 23V<br><br>AC power disconnected.<br>Battery not charged. | Connect system to AC power.<br><br>Tap the <b>Alarm Off</b> button to continue running on battery.<br><br>Tap the <b>Discard Set</b> button and change the set. |

| Alarm - Code(s)                     | Possible causes  | Corrective actions   |
|-------------------------------------|--|--|
| Battery Not Present - T1833         | Blown fuse in battery, system overtemp   | Blown fuse will require service; system overtemp (which should be accompanied by a T1055 alarm) should be handled by reducing the temperature of the environment, and making sure that nothing is obstructing fan vent in bottom of monitor.   |
| Battery Temperature Problem - T1054 | Battery temperature too low.   | Turn off the control unit.<br><br>Allow the control unit to acclimate to the ambient temperature for at least one hour.<br><br>Tap the <b>Alarm Off</b> button to override detection of this alarm.  |
| BLD Sensor Reading High - T1210     | <p>Blood Leak Detector (BLD) effluent line not detected</p> <p>Tubing incorrectly installed in Blood Leak Detector (BLD)</p> <p>Tubing is cloudy or debris in the tubing path. Air in the effluent line</p> <p>The wrong section of tubing is installed in the Blood Leak Detector (BLD)</p> <p>Dirty Blood Leak Detector (BLD) optics</p> | <p>Verify that effluent line is correctly installed in the Blood Leak Detector (BLD).</p> <p>If displayed transmissivity (detection signal) is 85 to 125%, tap the <b>Continue</b> button to reset the Blood Leak Detector (BLD).</p> <p>Slide the tube inside the Blood Leak Detector (BLD) to increase transmissivity (detection signal).</p> <p>Check for liquid or debris in the Blood Leak Detector (BLD) tubing path and effluent line: clean with a lint-free cloth, then dry thoroughly.</p> |
| Blood Flow Stopped - T0582          | <p>The blood pump has stopped for over 2 minutes and less than 10 minutes.</p> <p>Stop button pressed</p> <p>Unresolved alarm condition</p>  | <p>If any clotting is visible, change the set.</p> <p>Tap the <b>Continue</b> button to resume operation.</p>  |

| Alarm - Code(s)                                       | Possible causes   | Corrective actions  |
|---|---|---|
| Clamped Lines<br>Test Failed -<br>T1625               | <p>Access and return lines not clamped when set unloading is requested</p> <p>Access pod and or monitor line disconnected</p> | <p>Tap the <b>Alarm Off</b> button to override detection of this alarm.</p> <p>Clamp and disconnect red access and blue return lines from patient.</p> <p>Clamp all fluid/ effluent lines to the bags.</p> <p>Tap the <b>Retest</b> button to resume set unloading.</p> |
| Connectivity Test<br>- T2071                          | This is a test alarm for testing the remote alarm system  | <p>Use this to test the remote alarm system before starting therapy.</p> <p>Tap the <b>Continue</b> button to clear the alarm and return to normal operations.</p>  |
| Dialysate Bag<br>Overweight -<br>T1651                | The measured bag weight is at its maximum   | <p>Follow onscreen instructions to change bag.</p> <p>Remove foreign object from scale.</p>   |
| PBP Bag<br>Overweight -<br>T1649                      | <p>Incorrect bag</p> <p>Filter set unloaded before clamping fluid lines</p>   |   |
| Replacement<br>Bag/Container<br>Overweight -<br>T1650 | Foreign object on scale   |   |
| Replacement 2<br>Bag Overweight -<br>T1652            |   |   |

| Alarm - Code(s)  | Possible causes                           | Corrective actions   |
|--|---|--|
| Dialysate Scale Not Opened - T1086                             | Bag was changed without opening the scale | Tap the <b>Change Bag</b> button to resume operation.  |
| PBP Scale Not Opened - T1084                                   |   | If the alarm does not clear, tap the <b>Discard Set</b> button and change the set.   |
| Rep2 Scale Not Opened - T1198                                  |   |  |
| Replacement Scale Not Opened - T1087                           |   |  |
| Effluent Bag Full - T0801                                      | Effluent bag weight exceeds the maximum   | Follow onscreen instructions to change bag.  |
|  | Effluent bag is full                      | Change effluent bag size if needed.  |
|  | Incorrect effluent bag size setting       | Remove foreign object from scale.  |
|  | Foreign object on scale                   |  |
| Flow Problem - T1555, T1158, T1159, T1188, T1189, T1190, T1191 | Solution flow rate < set rate             |  <b>NOTE!</b><br>Alarm detection delayed for up to 40 seconds. |
|  | Kinked or clamped lines                   |  |
|  | Disconnected or leaking connections       | Correct kinked or clamped lines.   |
|  | Line connected to incorrect bag           | Verify line connections.   |
|  | Line touching another object              | Remove any object touching the bag.  |
|  | Leaking bag                               | Check the bag for leaks.   |
|  | Bag hanging on incorrect scale            | Verify that bag is hanging on correct scale.   |
|  |   | Tap the <b>Continue</b> button to resume operation.  |

| Alarm - Code(s)   | Possible causes  | Corrective actions   |
|---|--|--|
| Flow Problem -<br>T1552, T1553,<br>T1554, T1192,<br>T1193, T1194,<br>T1195, T1196,<br>T1197 | Estimated solution flow rate is less than half the expected value.<br><br>Kinked or clamped lines<br><br>Disconnected or leaking connections<br><br>Line connected to incorrect bag<br><br>Line touching other object<br><br>Leaking bag<br><br>Bag hanging on incorrect scale | <div style="display: flex; align-items: flex-start;"> <div style="margin-right: 20px;">  </div> <div> <p><b>NOTE!</b><br/>Alarm detection delayed for up to 40 seconds.</p> </div> </div> <p>Correct kinked or clamped lines.</p> <p>Verify line connections.</p> <p>Remove any object touching the bag.</p> <p>Check the bag for leaks.</p> <p>Verify that bag is hanging on correct scale.</p> <p>Tap the <b>Continue</b> button to resume operation.</p> |
| Fluid in Drip Tray - T0602  | Drip tray sensors detect fluid<br><br>Disconnections, punctures, or leaks in the blood line, fluid lines, or bags  | Inspect the entire set for leaks or disconnections.<br><br>Inspect the drip tray for fluid.<br><br>Clean drip tray according to hospital protocol.<br><br>Change bag if necessary.<br><br>Tap the <b>Alarm Off</b> button to resume operation.   |
| Front Effluent Scale Not Opened - T0818   | Bag was changed without opening the scale  | Tap the <b>Change Bag</b> button to resume operation.<br><br>If the alarm does not clear, tap the <b>Discard Set</b> button and change the set.  |
| Loss of AC Power - T0598  | No AC power<br><br>AC power disconnected   | Verify that power cord is securely connected to the control unit and AC power.<br><br>Tap the <b>Alarm Off</b> button to continue running on battery power.  |

| Alarm - Code(s)                        | Possible causes   | Corrective actions   |
|--|---|--|
| Membrane Pressure Rising - T0786       | Clamped or kinked line  | Correct kinked or clamped lines.   |
|  | Inadequate anticoagulation  | Check for air leak at filter or return pressure sensor.<br><br>Assess anticoagulation requirements according to hospital policy.   |
|  | Air leak at filter or return pressure sensor                              |  |
|  | High Rep, PBP, or PFR flow rate   | Consider decreasing these flow rates: PFR, Rep, or PBP.  |
| No Line in BLD - T1042                 | Too low blood flow rate   | Consider increasing Blood Flow Rate (BFR).<br><br>Tap "Change Flow" to bring up the change prescription screen and modify a flow rate to try to mitigate the alarm detection.<br><br>Tap the <b>Alarm Off</b> button to cancel the alarm and resume operation. |
|  | Blood Leak Detector (BLD) effluent line not detected                      | Verify that effluent line is correctly installed in the Blood Leak Detector (BLD).   |
|  | Tubing incorrectly installed in Blood Leak Detector (BLD)                 | If displayed transmissivity (detection signal) is 85 to 125%, tap the <b>Continue</b> button to reset the Blood Leak Detector (BLD).   |
|  | Tubing is cloudy or debris in the tubing path. Air in the effluent line   | Slide the tube inside the Blood Leak Detector (BLD) to increase transmissivity (detection signal).   |
| Dirty Blood Leak Detector (BLD) optics | The wrong section of tubing is installed in the Blood Leak Detector (BLD) | Check for liquid or debris in the Blood Leak Detector (BLD) tubing path and effluent line: clean with a lint-free cloth, then dry thoroughly.  |
|  |   | Tap the <b>Alarm Off</b> button to override detection of this alarm.   |

| Alarm - Code(s)                         | Possible causes  | Corrective actions   |
|---|--|--|
| No Line in Discharger - T1046           | <p>Discharger does not detect a line present</p> <p>Line missing</p> <p>Line incorrectly installed</p>   | <p>Verify that effluent line is correctly installed in the discharger.</p> <p>Slide the discharge ring up and down in the clip.</p>  |
| Prescription Changes Timeout - T1660    | Changes to the prescription have been entered but not accepted or cancelled within 5 minutes.  | Tap the <b>Continue</b> button, and re-enter prescription changes if needed.   |
| Preventive Maintenance Past Due - T1361 | System calibration is due or overdue   | Contact service to calibrate the system.   |
| Return Extremely Positive - T1164       | <p>Patient is moving, coughing, or being suctioned</p> <p>Blocked or clotted catheter</p> <p>Clamped or kinked return line</p> <p>Too high blood flow rate</p> | <p>Alarm clears if return pressure returns to normal limits within 15 seconds.</p> <p>Flush or reposition the catheter according to hospital protocol.</p> <p>Correct kinked or clamped lines.</p> <p>Consider decreasing Blood Flow Rate (BFR).</p> |
| Scale Calibration Temperature - T0820   | Ambient temperature differs from temperature at time of calibration  | <p>Move the system to a different location.</p> <p>Contact service for recalibration. Tap the <b>Continue</b> button to resume operation.</p>  |

| Alarm - Code(s)  | Possible causes  | Corrective actions   |
|--|--|--|
| Scale Open -<br>T0811, T0812,<br>T0813, T0934,<br>T0947, T1081,<br>T1281 | Scale position sensor indicates that its handle is open<br><br>Scale unexpectedly open<br><br>Object blocking scale<br><br>Bag improperly hung<br><br>Carrying bar not centered<br><br>Handle not rotated down | Follow onscreen instructions to check scale.<br><br>Close scale.<br><br>Change bag if needed.  |
| Syringe Not Detected -<br>T1298  | Syringe force sensor indicates low force during systemic anticoagulation<br><br>Syringe missing<br><br>Syringe improperly installed<br><br>Plunger not locked as shown in illustration                         | Verify that the syringe is correctly installed, with the plunger locked.<br><br>Verify that the line is correctly connected to the syringe.<br><br>If line, syringe, and plunger are correctly installed, tap the <b>Alarm Off</b> button to resume operation.<br><br>If alarm recurs or syringe, line, or plunger cannot be correctly installed, tap the <b>Change Syringe</b> button to install a new syringe. |
| Scale Unstable -<br>T1123, T1129,<br>T1130, T1131,<br>T1132, T1133       | The measured bag weight is unstable. Alarm detection is delayed after closing the scale.<br><br>Swinging bag<br><br>Bag supported from below<br><br>Bag touching another object                                | Correct swinging bag.<br><br>Remove partial support.<br><br>Remove any object touching the bag.  |

| Alarm - Code(s)                        | Possible causes   | Corrective actions  |
|--|---|---|
| Systemic Anticoagulation Empty - T1206 | Syringe plunger position indicates that the syringe is empty<br><br>Empty syringe | Follow onscreen instructions to change syringe.   |
| Wrong Effluent Bag Size - T0844        | Effluent bag weight is greater than expected                                      | Follow onscreen instructions to change the effluent bag.<br><br>Tap the <b>Alarm Off</b> button if bag size is correct. |

Table TPE alarms

| Alarm - Code(s)                  | Possible causes  | Corrective actions  |
|----------------------------------|--|---|
| Membrane Pressure Rising - T0787 | Clotted filter<br><br>Kinked lines   | Change filter set.<br><br>Unkink lines.<br><br>Increase anticoagulation.<br><br>Decrease Blood Flow Rate (BFR).<br><br>Tap the <b>Change Flow</b> button to bring up the change prescription screen and modify a flow rate to try to mitigate the alarm detection.<br><br>Tap the <b>Override</b> button to temporarily override the alarm. |
| Rep Container Empty - T0809      | Replacement container is empty<br><br>Something external is supporting the replacement container | Change the replacement container.<br><br>Move object supporting replacement container.  |

| Alarm - Code(s)                 | Possible causes                           | Corrective actions   |
|---------------------------------|---|--|
| TPE Treatment Completed - T2325 | Target exchange volume has been achieved. | <p>Change the exchange volume and tap the <b>Continue</b> button to extend treatment.</p> <p>Tap the <b>Discard Set</b> button and change the set.</p> |

Table TherMax alarms

| Alarm - Code(s)   | Possible causes  | Corrective actions   |
|---|--|--|
| <b>PrisMax</b> -<br><b>TherMax</b><br>Communication<br>Lost - T2255 | Disconnected cable between <b>TherMax</b> and <b>PrisMax</b> | Confirm the serial cable is connected between systems.   |
| <b>TherMax</b><br>Malfunction -<br>T2292                            | Clamped or kinked tubing                                     | <p>Confirm tubing on the return line including the warmer disposable is unobstructed.</p> <p>Tap the <b>Continue</b> button to clear the alarm and return to normal operations.</p> <p>Tap the <b>Discard Set</b> button and change the set.</p> |
| <b>TherMax</b><br>Malfunction -<br>T2295, T2298                     |  | <p>Tap the <b>Continue</b> button to clear the alarm and return to normal operations.</p> <p>Tap the <b>Discard Set</b> button and change the set.</p>   |

## Information alarms

Table General alarms

| Alarm - Code(s)                             | Possible causes  | Corrective actions   |
|---|--|--|
| Access Extremely Negative - T1238           | <p>Patient is moving, coughing, or being suctioned</p> <p>Blocked or clotted catheter</p> <p>Clamped or kinked access line</p> | <p>Flush or reposition the catheter according to hospital protocol.</p> <p>Correct kinked or clamped lines.</p> <p>Consider decreasing Blood Flow Rate (BFR).</p>  |
| Anticoagulation Checkpoint Reminder - T1119 | The preset reminder interval to assess anticoagulation has elapsed   | <p>Assess anticoagulation requirements according to hospital policy.</p> <p>Tap the <b>Continue</b> button to resume operation.</p>  |
| Battery Not Charging - T1199                | <p>Battery has stopped charging before being fully charged</p> <p>Battery overheated. Excessive charging time</p>              | <p>Allow system to cool down. Reset the system and allow the battery to charge.</p> <p>Tap the <b>Disable</b> button to prevent further detection of this alarm.</p>   |
| Bolus Interrupted - T0593                   | <p>Complete bolus not delivered</p> <p>Clamped syringe line</p> <p>Empty syringe</p> <p>Alarm condition</p>                    | <p>Verify that the line is correctly connected to the syringe.</p> <p>Tap the <b>Continue</b> button to resume operation.</p> <p>Administer the undelivered amount by tapping the <b>Administer Bolus</b> button on the Change screen.</p> |
| Flow Problem - T2161                        | <p>5L Auto Effluent (AE) bag is not draining</p> <p>Kinked or clamped line</p> <p>Debris in the 5L AE bag</p>                  | <p>Clear any line obstructions and tap the <b>Continue</b> button.</p> <p>Tap the <b>Discard Set</b> button if the problem continues.</p>  |

| Alarm - Code(s)                         | Possible causes  | Corrective actions  |
|---|--|---|
| Foam Detected in the LSS - 2315         | PrisMax has detected the presence of foam in the deaeration chamber  | <p>Tap the <b>Discard Set</b> button and change the set.</p> <p>Tap the <b>Override</b> button to disable automatic liquid levelling.</p>   |
| LLS Self-Test Failed - 2322             | Malfunction of the sensors for the deaeration chamber level.   | Tap the <b>Override</b> button to disable automatic liquid levelling.   |
| Patient Line Test In Progress - T1629   | Lines not clamped when set unloading is requested  | <p>Follow onscreen instructions for clamping and disconnecting all lines.</p> <p>Clamp and disconnect red access and blue return lines from patient.</p> <p>Clamp all fluid/ effluent lines to the bags.</p> <p>Tap the <b>Retest</b> button to resume set unloading.</p>       |
| Return Low Operating Point - T2240      | <p>The return operating point is low</p> <p>Disconnected patient catheter</p> <p>Disconnected return line</p> <p>Disconnected chamber monitor line</p> <p>Clamped fluid line</p> | <p>Check that the patient catheter, return line, and chamber monitor line are properly connected.</p> <p>Correct kinked or clamped lines.</p> <p>Tap the <b>Alarm Off</b> button to decrease the return disconnect limit.</p> <p>Consider increasing Blood Flow Rate (BFR).</p> |
| Schedule Preventive Maintenance - T1360 | System calibration is due or overdue   | <p>Contact service to calibrate the system.</p> <p>Tap the <b>Continue</b> button to clear the alarm and return to normal operations.</p>   |

Table TPE alarms

| Alarm - Code(s)              | Possible causes | Corrective actions   |
|------------------------------|-----------------|--|
| TMPa Pressure Rising - T2308 | Clotted filter  | Change filter set.   |
|                              | Kinked lines    | Unkink lines.  |
|                              |                 | Increase anticoagulation.  |
|                              |                 | Decrease Blood Flow Rate (BFR).  |
|                              |                 | Tap the <b>Continue</b> button to clear the alarm and return to normal operations. |

Table TherMax alarms

| Alarm - Code(s)                                    | Possible causes   | Corrective actions  |
|--|---|---|
| Blood Flow Rate Too Low For <b>TherMax</b> - T2283 | Low Blood Flow Rate (BFR)   | Increase the Blood Flow Rate (BFR).   |
| Blood Flow Rate Too Low For <b>TherMax</b> - T2289 | Clamped or kinked inlet or outlet tubing on warmer disposable   | Confirm that the inlet and outlet tubing on the warmer disposable is unobstructed.<br><br>Tap "Change Flow" to bring up the change prescription screen and modify a flow rate to try to mitigate the alarm detection. |
| Return Blood Temperature Low - T2290               | Warmer at heating limits as plate temperature is at maximum<br><br>Plate temperature is at the maximum limits | Decrease the return temperature.<br><br>Decrease the Blood Flow Rate (BFR).<br><br>Decrease the post replacement flow rate.   |

| Alarm - Code(s)                                   | Possible causes   | Corrective actions  |
|---|---|---|
| Return Blood Temperature Low - T2291              | Incompatible prescription   | Decrease the return temperature.<br><br>Decrease the Blood Flow Rate (BFR).<br><br>Decrease the post replacement flow rate.                                     |
| <b>TherMax</b> Detecting High Voltage - T2297     | Patient attached to AC power  | Disconnect the patient from the power source.   |
| <b>TherMax</b> Inlet Temperature Too High - T2282 | Kinked disposable inlet or outlet lines<br><br>Replacement solution is not at ambient temperature | Confirm lines are not obstructed.<br><br>Do not use warmed solutions.<br><br>Tap the <b>Continue</b> button to clear the alarm and return to normal operations. |
| <b>TherMax</b> Power Switch Off - T2288           | Warmer unit turned off during therapy<br><br>Warmer unit disconnected from AC power source        | Confirm the warmer unit is attached to the AC power source and that the membrane switch indicates that the warmer is turned on.                                 |

# Setup alarms

## Setup alarms

Table General alarms

| Alarm - Code(s)                             | Possible causes  | Corrective actions   |
|---|--|--|
| ABD Fluid Detected - T1654                  | Air Bubble Detector (ABD) detects fluid during setup for new patient | If the set is intentionally wet, tap the <b>Continue</b> button.   |
|   | Set is intentionally wet for demonstration purposes                  | If the set is unintentionally wet, tap the <b>Discard Set</b> button and change the set.                   |
|   | Set is wet or has debris in the Air Bubble Detector (ABD) sensor     | Remove any debris that may be blocking the Air Bubble Detector (ABD), then tap the <b>Continue</b> button. |
| Air Detected Flush - T2310                  | Empty priming bag  | Check priming bag.   |
|   | Open tubing connection   | Check line connections.  |
|   |  | Flush or reprime the set.  |
|   |  | If air continues discard the set.  |
| Air Detected in Prime - T2309               | Empty priming bag  | Check priming bag.   |
|   | Open tubing connection   | Check line connections.  |
|   |  | Reprime or discard the set.  |
|   |  | If air continues discard the set.  |
| Auto Effluent Bag Drain Pinch Valve - T1606 | Pinch valve has not reached its commanded position.                  | Tap the <b>Continue</b> button to clear the alarm and return to normal operations.                         |
|   |  | Tap the <b>Discard Set</b> button and change the set.  |

| Alarm - Code(s)                            | Possible causes  | Corrective actions   |
|--|--|--|
| Auto Effluent Bag Fill Pinch Valve - T1605 | Pinch valve has not reached its commanded position.  | Tap the <b>Continue</b> button to clear the alarm and return to normal operations.<br><br>Tap the <b>Discard Set</b> button and change the set.                        |
| Auto-Effluent Bags Nearly Full - T2243     | Auto effluent (AE) draining has been paused for too long and the bags are nearly full.   | Insert Auto Effluent (AE) drain line in drain, then resume draining.<br><br>Tap the <b>Continue</b> button to clear the alarm and return to normal operations.         |
| Auto Effluent Bags on Wrong Scales - T1175 | Unexpected weight on AE scales<br><br>Effluent bag hanging on the side scale<br><br>Incorrect AE bag filling<br><br>Pinch valve failure          | Confirm that bags are hanging on correct scales.<br><br>Discard Auto Effluent (AE) accessory.<br><br>Tap the <b>Continue</b> button.                                   |
| Bag on Wrong Scale - T2125                 | Unexpected weight on Auto Effluent (AE) scale<br><br>Effluent bag is on the wrong scale<br><br>Object is hanging on the Auto Effluent (AE) scale | Confirm that nothing is hanging on or touching the Auto Effluent (AE) scale.<br><br>Tap the <b>Continue</b> button to clear the alarm and return to normal operations. |
| Bag Not Filling - T1594, T1713             | Effluent bag is not filling during prime<br><br>Clamped lines<br><br>Bag partially supported<br><br>Return Line not connected                    | Check for clamped lines.<br><br>Check for bags touching or supported.<br><br>Check that Return Line is connected.<br><br>Tap the <b>Continue</b> button.               |

| Alarm - Code(s)              | Possible causes   | Corrective actions  |
|------------------------------|---|---|
| Bag Not Filling - T1714      | The <b>PrisMax</b> has not detected the correct fluid flow for re-using the AE.   | <p>Tap the <b>Continue</b> button to clear the alarm and return to normal operations.</p> <p>Tap the <b>Discard Set</b> button and change the set.</p>  |
| BLD Normalize Failed - T1313 | <p>Transmission below expected values</p> <p>Effluent line incorrectly installed</p> <p>Air bubbles in the effluent line</p> <p>Dirty effluent line</p> <p>Dirty Blood Leak Detector (BLD) mirrors</p> <p>Effluent Line Clamped</p> | <div style="display: flex; align-items: flex-start;"> <div style="margin-right: 10px;">  </div> <div> <p><b>NOTE!</b><br/>Alarm detection delayed for up to 40 seconds.</p> </div> </div> <p>Slide the tubing back and forth in the Blood Leak Detector (BLD).</p> <p>Squeeze the air bubbles out of the return line.</p> <p>Remove and clean the effluent line with an alcohol swab. Clean Blood Leak Detector (BLD) mirrors.</p> <p>Tap the <b>Continue</b> button to retest.</p> <p>Tap the <b>Discard Set</b> button and change the front set.</p> |

| Alarm - Code(s)                     | Possible causes   | Corrective actions   |
|-------------------------------------|---|--|
| BLD Self Test Failure - T1205       | <p>Air in the effluent line</p> <p>Effluent line incorrectly installed in the Blood Leak Detector (BLD)</p>   | <p>Check Blood Leak Detector (BLD)</p> <p>Verify that there are no air bubbles in the effluent line.</p> <p>Verify that effluent line is correctly installed in the Blood Leak Detector (BLD).</p> <p>Tap the <b>Continue</b> button to retry pinch valve position.</p> <p>If air is present in the entire return line, change the set.</p> <p>Tap the <b>Discard Set</b> button and change the set.</p> |
| Blood Pump Occlusivity Fail - T0850 | <p>Set is not holding pressure</p> <p>Leaks at bag connections</p> <p>Leak or wetting at the return pressure sensor</p> <p>Tubing not fully seated in pump raceways</p> <p>External set leakage (gluing, wrong blood warmer connection, anticoagulation line unclamped)</p> <p>Internal leak in the set</p> | <p>Check for leaks at fluid bag and return pressure sensor connections.</p> <p>Check the integrity of the disposable set.</p> <p>Unclamp the return line.</p> <p>Reload the set.</p> <p>Ensure there is more than 50ml remaining in the priming bag, then tap the <b>Continue</b> button to retest.</p> <p>Tap the <b>Discard Set</b> button and change the set.</p>                                     |
| Calibrate Syringe - T1701           | <p>Syringe arm obstructed during new patient test</p> <p>Syringe installed before test</p> <p>Obstruction</p> <p>Syringe arm/front panel is dirty</p>   | <p>Remove the syringe if present.</p> <p>Remove any obstructions.</p> <p>Clean the syringe arm/front panel.</p> <p>Recalibrate the syringe.</p> <p>Tap the <b>Continue</b> button to retest.</p>   |

| Alarm - Code(s)                                | Possible causes   | Corrective actions  |
|--|---|---|
| Check Syringe Line - T1570                     | <p>High force required to move the syringe</p> <p>Clamped or kinked syringe line</p> <p>Obstructed syringe arm</p> <p>Wrong syringe brand</p>       | <p>Unclamp syringe line.</p> <p>Confirm that syringe arm is unobstructed.</p> <p>Tap the <b>Continue</b> button to clear the alarm and return to normal operations.</p> <p>Tap the <b>Change Syringe</b> button to open the syringe change dialog window and begin a syringe change operation.</p> <p>Tap the <b>Discard Set</b> button and change the set.</p> |
| Defaults Not Set - T1722                       | <p>Installation is incomplete. A default setting is missing</p>   | <p>Use the System configuration function to enter the missing default settings (see "About system configuration", page 21).</p>   |
| Dia Line Attached to Rep Bag/Container - T1113 | <p>Set line connected to wrong bag</p> <p>Incorrect tubing line connection</p> <p>Bags touching or partially supported</p> <p>Scale disturbance</p> | <p>Verify that lines and bags are properly connected.</p> <p>If not, clamp lines, ensure that all connections are correct, then unclamp lines.</p> <p>Discard set if damaged.</p> <p>Tap the <b>Continue</b> button to restart prime.</p>   |

| Alarm - Code(s)                      | Possible causes                                     | Corrective actions   |
|--------------------------------------|---|--|
| Dia Line Attached to PBP - T1309     | Set line connected to wrong bag                     | Verify that lines and bags are properly connected.                                 |
|                                      | Incorrect tubing line connection                    | If not, clamp lines, ensure that all connections are correct, then unclamp lines.  |
|                                      | Bags touching or partially supported                | Discard set if damaged.  |
|                                      | Scale disturbance                                   | Tap the <b>Continue</b> button to restart prime.                                   |
| Dialysate Line Clamped - T1074       | Line is clamped or disconnected                     | Verify that lines are not kinked or clamped.                                       |
|                                      |   | Verify that bags are properly connected.   |
|                                      |   | Discard set if damaged.  |
|                                      |   | Tap the <b>Continue</b> button to restart prime.                                   |
| Dialysate Pinch Valve - T1604        | Pinch valve has not reached its commanded position. | Tap the <b>Continue</b> button to clear the alarm and return to normal operations. |
|                                      |   | Tap the <b>Discard Set</b> button and change the set.                              |
| Dialysate Scale Weight Error - T1347 | Empty solution bag                                  | Unclamp line.  |
|                                      | Clamped fluid line                                  | Change fluid bag.  |
| PBP Scale Weight Error - T1611       | Bag empty   | Tap the <b>Continue</b> button.  |
|                                      | Bag not properly connected to fluid line            |  |
| Rep Scale Weight Error - T1610       |   |  |
| Rep2 Scale Weight Error - T1778      |   |  |

| Alarm - Code(s)                                | Possible causes   | Corrective actions   |
|--|---|--|
| Effluent Bag Incorrect - T2217                 | The <b>PrisMax</b> did not detect the proper bag weight on the front effluent scale.  | Place the correct bag on the effluent scale and tap the <b>Continue</b> button to clear the alarm and return to normal operations.   |
| Effluent Bag Full - T1609                      | The bag is too small to hold the fluid required to complete prime<br><br>Effluent bag is partially full                                       | Tap the <b>Change Bag</b> button and replace the effluent bag.<br><br>Tap the <b>Continue</b> button to clear the alarm and return to normal operations.   |
| Effluent Bag Full - T2244                      | Effluent bag weight exceeds the maximum<br><br>Effluent bag is full<br><br>Incorrect effluent bag size setting<br><br>Foreign object on scale | Follow onscreen instructions to change bag.<br><br>Change effluent bag size if needed.<br><br>Remove foreign object from scale.<br><br>Tap the <b>Continue</b> button to clear the alarm and return to normal operations.          |
| Front Effluent Bag Incorrect - T1292           | Effluent bags hanging on incorrect scales   | Switch Auto Effluent (AE) bags between front and side scales as shown on screen.<br><br>Tap the <b>Continue</b> button.<br><br>Tap the <b>Discard Set</b> button and change the set.   |
| Incorrect Bag Connection - T1112, T1114, T1608 | Set line connected to wrong bag<br><br>Incorrect tubing line connection<br><br>Bags touching or partially supported<br><br>Scale disturbance  | Verify that lines and bags are properly connected.<br><br>If not, clamp lines, ensure that all connections are correct, then unclamp lines.<br><br>Discard set if damaged.<br><br>Tap the <b>Continue</b> button to restart prime. |

| Alarm - Code(s)                                       | Possible causes  | Corrective actions   |
|---|--|--|
| Incorrect Bag Connection - T1776                      | <p>Set line unconnected</p> <p>Incorrect tubing line connection</p> <p>Bags touching or partially supported</p> <p>Line is clamped or disconnected</p>   | <p>Verify that lines are not kinked or clamped.</p> <p>Verify that bags are properly connected.</p> <p>Discard set if damaged.</p> <p>Tap the <b>Continue</b> button to restart prime.</p>             |
| Line in Component - T1712, T1723, T1724, T1725, T1726 | <p>New patient selected and tubing line installed in a component</p> <p>Tubing line remains in component from a previous treatment</p> <p>Accidental new patient selection</p>   | <p>Remove tubing lines from components.</p> <p>Tap the <b>Open Clamp</b> button to open the clamp and remove the line.</p>   |
| Line Misconnected - T2131, T2132                      | <p>Line is not connected correctly during prime</p> <p>Effluent line is connected to the used Auto Effluent (AE) accessory</p> <p>Effluent line is connected to the new 5-L effluent bag</p> <p>Return line is connected to the priming bag</p> <p>Return line is connected to the Auto Effluent (AE) effluent bag</p> | <p>Connect the effluent line to the priming bag.</p> <p>Connect the return line to the new effluent bag.</p> <p>Tap the <b>Continue</b> button to clear the alarm and return to normal operations.</p> |

| Alarm - Code(s)   | Possible causes  | Corrective actions  |
|---|--|---|
| Liquid Level Sensor Fail - T1616  | The liquid level sensor in the deaeration chamber is not sensing the chamber.  | <p>Tap the <b>Continue</b> button to resume operation.</p> <p>Remove the chamber from the Liquid Level Sensor (LLS) and reinstall.</p> <p>If the alarm recurs, tap the <b>Alarm Off</b> button to disable auto-leveling.</p> <p>Perform a self test.</p>      |
| <div style="display: flex; align-items: center;">  <p><b>NOTE!</b><br/>Follow hospital protocol if connecting the return line to the used auto effluent (AE) accessory compromises sterility.</p> </div> |  |   |
| Main Set Loader Failed - T1137  | <p>Tubes interfering with plastic cassette</p> <p>Pinch valves engaged</p> <p>Obstructions</p>   | <p>Tap the <b>Discard Set</b> button to replace filter set.</p> <p>Tap the <b>Continue</b> button once the problem is resolved.</p>   |
| No Line in BLD - T1612  | <p>No effluent line detected in Blood Leak Detector (BLD)</p> <p>Effluent line missing from Blood Leak Detector (BLD)</p> <p>Effluent line not fully seated in Blood Leak Detector (BLD)</p> | <p>Install effluent tubing in the Blood Leak Detector (BLD).</p> <p>Slide the tubing back and forth in the Blood Leak Detector (BLD).</p> <p>Tap the <b>Continue</b> button to retest.</p> <p>Tap the <b>Discard Set</b> button and change the front set.</p> |

| Alarm - Code(s)                                | Possible causes                      | Corrective actions  |
|--|--------------------------------------|---|
| PBP Line Attached to Dia - T1308               | Set line connected to wrong bag      | Verify that lines and bags are properly connected.                                |
|  | Incorrect tubing line connection     | If not, clamp lines, ensure that all connections are correct, then unclamp lines. |
|  | Bags touching or partially supported | Discard set if damaged.   |
|  | Scale disturbance                    | Tap the <b>Continue</b> button to restart prime.                                  |
| PBP Line Attached to Rep Bag/Container - T0610 | Set line connected to wrong bag      | Verify that lines and bags are properly connected.                                |
|  | Incorrect tubing line connection     | If not, clamp lines, ensure that all connections are correct, then unclamp lines. |
|  | Bags touching or partially supported | Discard set if damaged.   |
|  | Scale disturbance                    | Tap the <b>Continue</b> button to restart prime.                                  |
| PBP Line Attached to Rep2 - T1773              | Set line connected to wrong bag      | Verify that lines and bags are properly connected.                                |
|  | Incorrect tubing line connection     | If not, clamp lines, ensure that all connections are correct, then unclamp lines. |
|  | Bags touching or partially supported | Discard set if damaged.   |
|  | Scale disturbance                    | Tap the <b>Continue</b> button to restart prime.                                  |
| PBP Line Clamped - T1075                       | Line is clamped or disconnected      | Verify that lines are not kinked or clamped.                                      |
|  |                                      | Verify that bags are properly connected.  |
|  |                                      | Discard set if damaged.   |
|  |                                      | Tap the <b>Continue</b> button to restart prime.                                  |

| Alarm - Code(s)                                | Possible causes  | Corrective actions  |
|--|--|---|
| Pressure Detected - T1333, T1334, T1335, T1337 | <p>New patient selected and pressure is non-zero</p> <p>Pressure pods/return line remain from a previous treatment</p> <p>Accidental new patient selection</p> | <p>Remove pod or return line from the control unit.</p> <p>Tap the <b>Continue</b> button to clear the alarm and return to normal operations.</p> <p>Contact service to calibrate the system or to clean pressure sensors (wet) or to change the pressure system (failure).</p> |
| Prime Solution Empty - T1305                   | Priming bag is empty   | <p>Follow the onscreen instructions to change the priming bag and restart priming.</p> <p>Discard set if damaged.</p> <p>If a too large amount of air has entered the blood circuit, it is recommended to restart priming and closely monitor for air trapping.</p>             |
| Priming Pause Time Exceeded - T1144            | <p>Delay too long between prime and the start of therapy</p> <p>Patient not connected after prime complete</p>   | <p>A delay of over 60 minutes since prime complete.</p> <p>Follow the onscreen instructions to reprime or flush the set.</p>  |
| Rep Line Attached to Dia - T1310               | <p>Set line connected to wrong bag</p> <p>Incorrect tubing line connection</p> <p>Bags touching or partially supported</p> <p>Scale disturbance</p>            | <p>Verify that lines and bags are properly connected.</p> <p>If not, clamp lines, ensure that all connections are correct, then unclamp lines.</p> <p>Discard set if damaged.</p> <p>Tap the <b>Continue</b> button to restart prime.</p>                                       |

| Alarm - Code(s)                            | Possible causes                      | Corrective actions  |
|--|--------------------------------------|---|
| Rep Line Attached to PBP Bag - T1607       | Set line connected to wrong bag      | Verify that lines and bags are properly connected.                                |
|  | Incorrect tubing line connection     | If not, clamp lines, ensure that all connections are correct, then unclamp lines. |
|  | Bags touching or partially supported | Discard set if damaged.   |
|  | Scale disturbance                    | Tap the <b>Continue</b> button to restart prime.                                  |
| Rep Line Attached to Rep2 - T1777          | Set line connected to wrong bag      | Verify that lines and bags are properly connected.                                |
|  | Incorrect tubing line connection     | If not, clamp lines, ensure that all connections are correct, then unclamp lines. |
|  | Bags touching or partially supported | Discard set if damaged.   |
|  | Scale disturbance                    | Tap the <b>Continue</b> button to restart prime.                                  |
| Rep2 Attached to Rep Bag/Container - T1775 | Set line connected to wrong bag      | Verify that lines and bags are properly connected.                                |
|  | Incorrect tubing line connection     | If not, clamp lines, ensure that all connections are correct, then unclamp lines. |
|  | Bags touching or partially supported | Discard set if damaged.   |
|  | Scale disturbance                    | Tap the <b>Continue</b> button to restart prime.                                  |
| Rep2 Line Attached to PBP - T1774          | Set line connected to wrong bag      | Verify that lines and bags are properly connected.                                |
|  | Incorrect tubing line connection     | If not, clamp lines, ensure that all connections are correct, then unclamp lines. |
|  | Bags touching or partially supported | Discard set if damaged.   |
|  | Scale disturbance                    | Tap the <b>Continue</b> button to restart prime.                                  |

| Alarm - Code(s)                   | Possible causes  | Corrective actions  |
|-----------------------------------|--|---|
| Rep2 Line Clamped - T1772         | <p>Set line kinked or clamped</p> <p>Incorrect tubing line connection</p> <p>Bags touching or partially supported</p> <p>Scale disturbance</p> | <p>Verify that lines and bags are properly connected.</p> <p>If not, clamp lines, ensure that all connections are correct, then unclamp lines.</p> <p>Discard set if damaged.</p> <p>Tap the <b>Continue</b> button to restart prime.</p> |
| Replacement Line Clamped - T1073  | <p>Line is clamped or disconnected</p>   | <p>Verify that lines are not kinked or clamped.</p> <p>Verify that bags are properly connected.</p> <p>Discard set if damaged.</p> <p>Tap the <b>Continue</b> button to restart prime.</p>  |
| Replacement Pinch Valve - T1603   | <p>Pinch valve has not reached its commanded position.</p>   | <p>Tap the <b>Continue</b> button to clear the alarm and return to normal operations.</p> <p>Tap the <b>Discard Set</b> button and change the set.</p>  |
| Return Barrier May Be Wet - T1816 | <p>Return chamber monitor line may be wet</p>  | <p>Tap the <b>Alarm Off</b> button to override detection of this alarm.</p> <p>If fluid barrier is wet, tap the <b>Discard Set</b> button and change set.</p> <p>Tap the <b>Continue</b> button to retest the fluid barrier.</p>          |

| Alarm - Code(s)  | Possible causes                                       | Corrective actions  |
|--|---|---|
| Scale Weight Problem - T1318, T1319, T1320, T1321, T1322 | New patient selected and scales detect weight         | Remove bags/external objects from the scales.   |
|  | Fluid bags remain on scales from a previous treatment | Close the scale handle.<br>Hang the bag handle on the scale.  |
|  | Open or partially open scale                          |   |
|  | Bag handle missing                                    | Contact service to calibrate the system.  |
|  | Accidental new patient selection                      |   |
|  | Foreign object on scale                               |   |
| Side Effluent Bag Incorrect - T1291                      | Effluent bags hanging on incorrect scales             | Switch Auto Effluent (AE) bags between front and side scales as shown on screen.<br>Tap the <b>Continue</b> button. |
|  |   | Tap the <b>Discard Set</b> button and change the set.   |
|  |   |   |
| Syringe Arm Interrupted - T1703                          | Syringe arm obstructed during new patient test        | Remove the syringe if present.<br>Remove any obstructions.  |
|  | Syringe installed before test                         | Clean the syringe arm/front panel.  |
|  | Obstruction   |   |
|  | Syringe arm/front panel is dirty                      | Recalibrate the syringe.<br>Tap the <b>Continue</b> button to retest.   |
|  |   |   |
| Syringe Force Sticky - T1704                             | Syringe arm obstructed during new patient test        | Remove the syringe if present.<br>Remove any obstructions.  |
|  | Syringe installed before test                         | Clean the syringe arm/front panel.  |
|  | Obstruction   |   |
|  | Syringe arm/front panel is dirty                      | Recalibrate the syringe.<br>Tap the <b>Continue</b> button to retest.   |
|  |   |   |

| Alarm - Code(s)            | Possible causes                        | Corrective actions  |
|----------------------------|--|---|
| Wrong Set Detected - T0608 | Wrong set loaded                       | Load correct set.   |
|                            | Return line not in clamp               | Place return line in clamp.<br><br>Tap the <b>Continue</b> button to clear the alarm and return to normal operations.<br><br>Tap the <b>Discard Set</b> button and change the set.                |
| Wrong Set Detected - T0609 | Filter set does not match prescription | Discard set and load correct filter set.  |
|                            | Incorrect set loaded                   | Unclamp effluent line.  |
|                            | Clamped effluent line                  | Verify that effluent bag is on effluent scale.<br><br>Tap the <b>Continue</b> button to retest.   |
| Wrong Set Detected - T1783 | Wrong set selected                     | Change the set.   |
|                            | Return line not in return clamp        | Place the return line in the return clamp.<br><br>Tap the <b>Continue</b> button to clear the alarm and return to normal operations.<br><br>Tap the <b>Discard Set</b> button and change the set. |

Table TPE alarms

| Alarm - Code(s)                           | Possible causes  | Corrective actions   |
|---|--|--|
| Bag Not Filling - T2224                   | <p>Priming solution is empty</p> <p>Return line not connected to effluent bag</p> <p>Clamped or kinked return line</p> | <p>Check priming solution.</p> <p>Connect return line to effluent bag.</p> <p>Check for clamped or kinked lines.</p> <p>Tap the <b>Continue</b> button to clear the alarm and return to normal operations.</p> |
| Effluent Bag Full - T1705                 | <p>Effluent bag is too full</p>  | <p>Empty effluent bag.</p> <p>Tap the <b>Continue</b> button to clear the alarm and return to normal operations.</p>   |
| Return Line Disconnected in Prime - T2280 | <p>Priming solution is empty</p> <p>Return line not connected to effluent bag</p> <p>Clamped or kinked return line</p> | <p>Check priming solution.</p> <p>Connect return line to effluent bag.</p> <p>Check for clamped or kinked lines.</p> <p>Tap the <b>Continue</b> button to clear the alarm and return to normal operations.</p> |
| TPE Prime Solution Empty - T1658          | <p>Priming bag is empty</p>  | <p>Change priming bag.</p> <p>Tap the <b>Continue</b> button to clear the alarm and return to normal operations.</p>   |

Table TherMax alarms

| Alarm - Code(s)                                 | Possible causes  | Corrective actions   |
|---|--|--|
| <b>TherMax</b> Bag Not Connected to Set - T2281 | Warmer disposable not detected during prime  | <p>Cancel prime and load the warmer disposable.</p> <p>Confirm that the warmer disposable is pushed in all the way.</p> <p>Tap the <b>Continue</b> button to retry the disposable connected test. Tap the <b>Reprime</b> button to start priming all over again.</p> |
| <b>TherMax</b> Bag Not Inflated - T2300         | Leak from warmer disposable  | <p>Confirm connection.</p> <p>Discontinue setup and use a new warmer disposable if alarm persists.</p> <p>Tap the <b>Continue</b> button to clear the alarm and return to normal operations.</p>   |
| <b>TherMax</b> Cover Open - T2275               | <p><b>TherMax</b> is open in the cleaning position</p> <p>Top cover latches are not fully closed</p> | <p>Lower the upper portion of the warmer and confirm that the latches are engaged.</p> <p>Tap the <b>Discard Set</b> button and change the set.</p>  |
| <b>TherMax</b> Disposable Installed - T0943     | <p>Disposable installed too early</p> <p>Previous disposable not removed from last treatment</p>     | Remove the warmer disposable from the warmer unit.   |

| Alarm - Code(s)                      | Possible causes   | Corrective actions                                    |
|--------------------------------------|---|---|
| <b>TherMax</b> Fluid Present - T2303 | Fluid has been detected in the <b>TherMax</b> device.                     | Tap the <b>Discard Set</b> button and change the set. |
| <b>TherMax</b> Not Level - T2304     | The TherMax blood warmer is not sufficiently level for proper operations. | Tap the <b>Discard Set</b> button and change the set. |

## Malfunction alarms

### About malfunction alarms

Malfunction alarms indicate that a system component has failed.

- Certain component failures (retest alarms) allow retesting that can correct the alarm.
- Other component failures (Call Service alarms) can only be corrected by a service technician ( "Call service alarms", page 153).

### Operator response

You can correct some retest alarms, while Call Service alarms require service by an authorized service technician. The Alarm screen gives instructions for responding to the malfunction alarm. When the alarm is corrected:

- The malfunction alarm screen closes
- The status light turns green (non-flashing)
- The blood pump restarts and return line clamp opens  
The other pumps restart several seconds later.

If the operator cannot correct a malfunction alarm:

1. Check the patient and clamp the access and return lines
2. End the treatment with or without returning blood  
( "About manually terminating a treatment", page 87, describes how to manually terminate a treatment)

3. Turn off the control unit

4. Restart the control unit

If the alarm recurs, contact an authorized service technician and report the alarm code before using the control unit again.

### Call service alarms

Call Service alarms ("Call service alarm", page 153) occur if patient safety cannot be monitored due to a system failure; for example, failure during self tests, software error, or hardware failure. During a call service alarm:

- The system enters a “safe state” by stopping all pumps and closing the return line clamp. Treatment is suspended, and blood does not circulate through the flow path.
- The status light flashes red
- The audible alarm sounds (5 sound pulses repeated with a 10-second pause until muted)

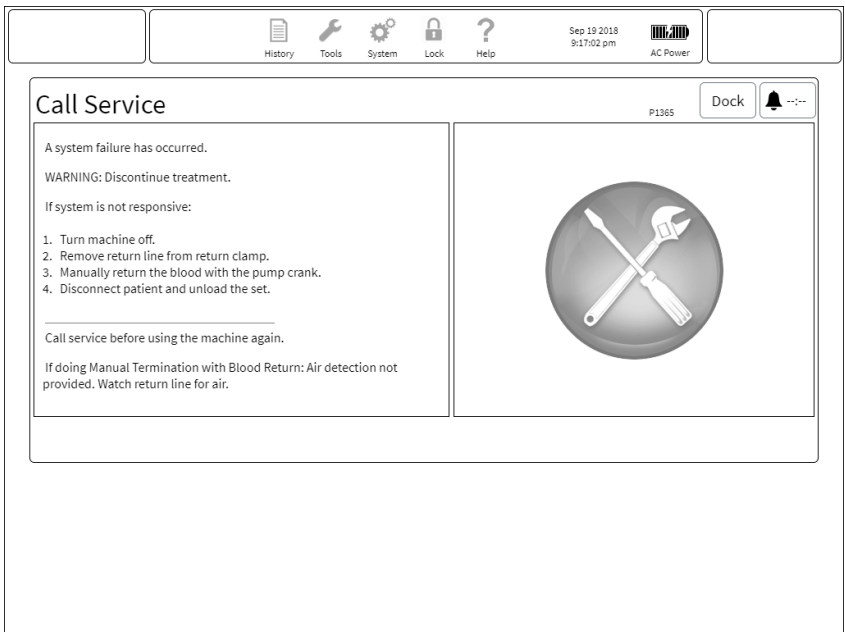

Figure Call service alarm



#### **WARNING!**

There is no air detection during manual blood return. Observe the return line for air until the patient is disconnected. Stop the manual blood return if air is visible.

**NOTE!**

Once blood has been returned, treatment cannot resume until a new set is loaded.

## Alarm off/override alarms

Some alarm windows include onscreen instructions to tap the **Override** or **Alarm Off** buttons to override the alarm.

During the override period:

- The alarm screen closes
- The status light turns green
- The override symbol appears at the top of the screen
- The blood pump restarts and return line clamp opens

The other pumps restart several seconds later.

When overriding a single alarm, it is possible to override additional related alarms. All of the overridden alarms will appear in the override window. It is possible to clear all of the overrides by tapping the **CLEAR ALL** button.

When the override period is complete, the alarm either clears or recurs. This table summarizes override alarm conditions:

Table General alarms

| Alarm - Code(s)                            | Override action  | Override clear  |
|--|--|---|
| Alarm Sound Test Failure - T0890           | Disables verification that alarm sound was played.       | Override shall be automatically cleared when the operator sets the alarm volume to the default value of 85 % or higher.<br><br>When the operator clears the Override, and the alarm volume is < the default value of 85 %, then the alarm volume shall be set to the default value of 85 %. |
| Auto Effluent Max Set Life Reached - T2119 | Clears and disables detection of the AEA Set Life alarm. | Override shall be automatically cleared when therapy transitions to a new state.  |
| Battery Depleted - T0597                   | Disables alarm detection                                 | Clears if the AC power is restored for 2 seconds  |
| Battery Low - T0596                        | Disables detection of the Battery Exhausted alarm.       | Override shall be automatically cleared if the alarm condition is no longer present.  |
| Battery Not Charging - T1199               | Disables detection of the Battery not Charging alarm.    | Override shall be automatically cleared if the alarm condition is no longer present.  |
| Battery Not Present - T1833                | Disables detection of the battery not present alarm.     | Override shall be automatically cleared if the alarm condition is no longer present.  |
| Battery Temperature Problem - T1054        | Disables detection of the Battery Low Temp alarm.        | Override shall be automatically cleared if the alarm condition is no longer present.  |

| Alarm - Code(s)                     | Override action   | Override clear   |
|-------------------------------------|---|--|
| Battery Temperature Problem - T1055 | Disables detection of the Battery High Temp alarm.  | Override shall be automatically cleared if the alarm condition is no longer present.   |
| Blood Leak Detected - T0830         | <p>Disables blood leak detector (BLD) for 60 seconds</p> <p>Disables blood leak detection or renormalization, or both, when override is active.</p> | <p> <b>NOTE!</b><br/>Alarm detection delayed for up to 40 seconds.</p> <p>Override shall be automatically cleared 60 seconds after it is set.</p> |
| Chamber Level High - T1591          | Automatic leveling of the fluid level in the aeration chamber is disabled.  | <p>Override shall be cleared when the operator selects the <b>Enable LLS</b> button from the Chamber Adjust dialog.</p> <p>When override is cleared, the automatic leveling of fluid in the aeration chamber shall be enabled.</p> |
| Chamber Level Low - T1279           | Automatic leveling of the fluid level in the aeration chamber is disabled.  | <p>Override shall be cleared when the operator selects the <b>Enable LLS</b> button from the Chamber Adjust dialog.</p> <p>When override is cleared, the automatic leveling of fluid in the aeration chamber shall be enabled.</p> |
| Check Access - T1145                | Disables the check access alarm.  | Override shall be cleared if the access operating point is set to a value $\leq -15\text{mmHg}$ , or $\geq +25\text{ mmHg}$ .  |
| Clamped Lines Test Failed - T1625   | Disables or clears detection of the Patient Lines Clamped Test alarm.   | Discontinue therapy  |

| Alarm - Code(s)                   | Override action  | Override clear   |
|-----------------------------------|--|--|
| CRRT Max Set Life Reached - T1262 | Clears and disables detection of the linked MAX_SET_LIFE alarms.           | Override shall be automatically cleared when therapy transitions to a new state.   |
| Fluid in Drip Tray - T0602        | Disables detection of the drip tray alarms which reference this override.  | Override shall be automatically cleared when the drip tray sensor indicate dry for a period of 60 seconds.   |
| Foam Detected - T2315             | Automatic leveling of the fluid level in the aeration chamber is disabled. | <p>Override shall be cleared when the operator selects the <b>Enable LLS</b> button from the Chamber Adjust dialog.</p> <p>When override is cleared, the automatic leveling of fluid in the aeration chamber shall be enabled.</p> |
| LLS Self-Test Failed - T2322      | Automatic leveling of the fluid level in the aeration chamber is disabled. | <p>Override shall be cleared when the operator selects the <b>Enable LLS</b> button from the Chamber Adjust dialog.</p> <p>When override is cleared, the automatic leveling of fluid in the aeration chamber shall be enabled.</p> |
| Loss of AC power - T0598          | Disables detection of the Loss of AC Power alarm.                          | Override shall be automatically cleared if the alarm condition is no longer present.   |
| Max Set Life Reached - T1267      | Clears and disables detection of the linked MAX_SET_LIFE alarms.           | Override shall be automatically cleared when therapy transitions to a new state.   |

| Alarm - Code(s)                                | Override action  | Override clear   |
|--|--|--|
| Membrane Pressure Rising - T0786, T0787, T0788 | Allows therapy to continue until pressure increases above the specified limit.   | In CRRT, the override shall be cleared if both of the following conditions are true: <ul style="list-style-type: none"> <li>• The change in filter pressure drop is less than the maximum value defined for the set.</li> <li>• The change in the TMP is less than the maximum value defined for the set.</li> </ul> |
| No Line In BLD - T1042                         | Disables blood leak detector (BLD) for 60 seconds<br><br>Disables blood leak detection or renormalization, or both, when override is active. | Override shall be automatically cleared 60 seconds after it is set.  |
| Normalization Failure - T0853                  | Disables blood leak detector (BLD) for 60 seconds<br><br>Disables blood leak detection or renormalization, or both, when override is active. |  <b>NOTE!</b><br>Alarm detection delayed for up to 40 seconds.<br><br>Override shall be automatically cleared 60 seconds after it is set.   |
| PBP Fluid Limit Reached - T0800                | Allows therapy to continue until the PBP Fluid Gain increases above the specified limit.   | Discontinue therapy  |
| Preventive Maintenance Past Due - T1361        | Disables or clears detection of the PM Past Due alarm.   | Discontinue therapy  |

| Alarm - Code(s)                           | Override action   | Override clear   |
|---|---|--|
| Return Low Operating Point - T1162, T2240 | The Return Disconnect Limit (RDT) is modified from its default value. | Override clears when return pressure is > 20 mmHg for 2 seconds<br><br>Override shall be automatically cleared when the RDL is set to the default value. |
| Syringe Not Detected - T1298              | Clears and disables detection of the syringe force low alarms         | Override shall be automatically cleared if the alarm is cleared.   |
| TPE Max Set Life Reached - T1268          | Clears and disables detection of the linked MAX_SET_LIFE alarms.      | Override shall be automatically cleared when therapy transitions to a new state.   |
| Wrong Effluent Bag Size - T0844           | Clears and disables detection of the ALARM_EFFLUENT_BAG_VOLUME alarm. | Discontinue therapy  |

Table **TherMax** alarms

| Alarm - Code(s)                                    | Override action                 | Override clear  |
|--|---------------------------------|---|
| Ambient Temperature Sensor Failure - T2314         | Disables <b>TherMax</b> heating | Override will be automatically cleared and heating will continue if the alarm condition is no longer present. |
| Blood Flow Rate Too Low - T2238                    | Disables <b>TherMax</b> heating | Override will be automatically cleared and heating will continue if the alarm condition is no longer present. |
| Blood Flow Rate Too Low For <b>TherMax</b> - T2289 | Disables <b>TherMax</b> heating | Override will be automatically cleared and heating will continue if the alarm condition is no longer present. |

| Alarm - Code(s)   | Override action                    | Override clear  |
|---|------------------------------------|---|
| <b>PrisMax - TherMax</b><br>Communication Lost -<br>T2255 | Disables <b>TherMax</b><br>heating | Override will be<br>automatically cleared and<br>heating will continue if<br>the alarm condition is no<br>longer present. |
| Return Blood<br>Temperature Low -<br>T2290, T2291         | Disables <b>TherMax</b><br>heating | Override will be<br>automatically cleared and<br>heating will continue if<br>the alarm condition is no<br>longer present. |
| <b>TherMax</b> Detecting High<br>Voltage - T2297          | Disables <b>TherMax</b><br>heating | Override will be<br>automatically cleared and<br>heating will continue if<br>the alarm condition is no<br>longer present. |
| <b>TherMax</b> Malfunction -<br>T2254, T2295              | Disables <b>TherMax</b><br>heating | Override will be<br>automatically cleared and<br>heating will continue if<br>the alarm condition is no<br>longer present. |
| <b>TherMax</b> Malfunction -<br>T2298                     | Disables <b>TherMax</b><br>heating | Discontinue therapy   |
| <b>TherMax</b> Not Level -<br>T2302                       | Disables <b>TherMax</b><br>heating | Override will be<br>automatically cleared and<br>heating will continue if<br>the alarm condition is no<br>longer present. |
| <b>TherMax</b> Power Switch<br>Off - T2288                | Disables <b>TherMax</b><br>heating | Override will be<br>automatically cleared<br>when TherMax powered<br>on and heating enabled.                              |
| <b>TherMax</b> Leak Detector<br>Error - T2293             | Disables <b>TherMax</b><br>heating | Override will be<br>automatically cleared and<br>heating will continue if<br>the alarm condition is no<br>longer present. |

## Multiple alarm management

There may be scenarios that occur where multiple alarms are declared close together with respect to time, or an alarm is declared while the operator is mitigating an already declared alarm. **PrisMax** will by default always display the highest priority first. This ensures that the operator is informed about the most critical mitigation actions to take. Certain scenarios though can arise where a lower priority alarm must be dealt with before a higher priority alarm can be dismissed. For example:

A lower priority alarm has closed the clamp, but a higher priority alarm needs to open the clamp to complete mitigation efforts.

In cases of multiple concurrent alarms declared, **PrisMax** gives the user the option to view the list of currently declared alarms and deal with them in the order they deem necessary. When multiple alarms are present, the operator can tap on the **More Alarms** button and a list of scrollable alarms will appear below the current alarm window. These alarm titles are colored appropriate to their priority level. The operator can scroll and select a line, then tap the **Select** button to display the highlighted alarm. The **More Alarms** button is not available when there is only one currently declared alarm.

### **Alarm window shortcut buttons**

When an alarm is declared where the user would have to begin some major action to mitigate the alarm (for example: change the blood flow rate on an access negative alarm, change the fluid bag on a bag empty alarm), the alarm window will display a button which when pressed will automatically dock the alarm and bring the operator to the relevant screen (prescription screen or bag change dialog per the examples above) to perform the desired actions.

### **Alarm shortcut interaction with pending operator actions**

If the operator is currently in a scenario that cannot be automatically dismissed (for example: bag change, adjusting chamber level, etc) and an alarm window is displayed that has a shortcut button, the shortcut button is disabled. Pressing the disabled shortcut button (for example: **Change Flow, Change Syringe**) will remind the user what actions are to be taken to finish the tasks. The alarm must be docked, the underlying operation must be completed, then the alarm can be un-docked and dealt with. For example:

The operator is in the middle of changing the anticoagulation syringe when an alarm is declared with a **Change Flow** shortcut button. The

underlying syringe change cannot be cancelled. This is why the operator must take the action to address the conflicting actions.

## Events

During normal system operation, the system records in the events log. Events include but are not limited to:

- Changed patient information
- Barcode scanned
- Flow rates changed
- Anticoagulation initialized/stopped/changed
- Set loaded/unloaded
- Syringe installed/removed/changed
- Syringe bolus
- Operation mode (Setup/Prime/Therapy/End/Recirculation)
- Bag change
- Periodic self test
- Date and time change
- POST and BIOT failures
- Prescription change

To view the events log, tap the **History** button from the toolbar, then select **Events**. The screen shows events in order of most recent. Symbols indicate each event type (setting, alarm, etc.). At the upper right corner of the Events screen, the operator can choose to show all events or specific event categories (settings, alarms, overrides, messages, or technical).

# Troubleshooting

## About troubleshooting

**WARNING!**

There are no user-serviceable parts inside the control unit. Do not open the control unit or attempt any internal or external maintenance or repair, other than the routine cleaning described in this manual. An authorized service technician must perform all other maintenance and repairs.

**WARNING!**

Do not tamper with or modify pumps or protective pump components. If tampering is evident, do not use until an authorized service technician has verified correct system operation.

**NOTE!**

The alarm log is updated every second to maintain the log in case of a shutdown or complete loss of power.

**NOTE!**

Following any maintenance or repair, a qualified service technician must perform electrical safety testing as described in the **PrisMax** System Service Manual, including an earth leakage current test and protective earth conductivity test.

For service or to order parts, contact your Baxter representative.

## Miscellaneous troubleshooting

Perform corrective actions in the order listed until the problem is resolved. Contact service if the problem cannot be resolved.

Table **Miscellaneous troubleshooting - Corrective actions**

| <b>Description</b>  | <b>Possible cause</b>  | <b>Corrective action</b>   |
|---|--|--|
| <p>Status light does not work correctly.</p> <p>Audible alarm does not turn on or off.</p> <p>Onscreen buttons do not work correctly.</p> <p>Blank or frozen display.</p> | <p>Power lost and restored within 15 seconds.</p> <p>Power loss.</p> <p>Display, touchscreen, power supply, or other internal component failure.</p> | <p>No action required if the display goes blank momentarily then reappears.</p> <p>If the display is frozen (locked), verify that screen lock is not active. If the display remains unresponsive, restart the control unit.</p> <p>In case of power failure, follow the onscreen instructions, which depend on how long power was interrupted.</p> <p>If the system resumes normal operation, no further action is required.</p> <p>See "Power failure", page 166, for more information on power failure.</p> <p>If the system detects an internal failure that cannot be corrected, stop treatment immediately. If needed, manually terminate the treatment ( "About manually terminating a treatment", page 87).</p> |

| Description   | Possible cause  | Corrective action  |
|---|---|--|
| <p>The control unit does not turn on.</p> <p>The control unit does not start correctly.</p> | <p>Control unit experienced a total loss of power last time it was powered off, and must be connected to AC power before it can turn on.</p> <p>Defective power supply.</p> <p>Defective internal battery.</p> <p>Defective On/Standby button.</p> <p>Other internal failure.</p> | <p>Verify that power cord is plugged in and that On/Standby indicator (green LED) is on, indicating that power is present.</p> <p>Allow at least 60 seconds for the <b>PrisMax</b> to start up.</p>  |
| <p>Barcode reader does not operate correctly.</p>   | <p>Barcode configuration changed.</p> <p>Barcode label is damaged.</p> <p>Barcode reader lens is dirty.</p> <p>Defective bar code reader.</p> <p>Other internal failure.</p>  | <p>Reset the barcode reader (tap the <b>Tools</b> button then select <b>Reset Barcode Reader</b>).</p> <p>Use the barcode scanner to scan the square barcode: a beep indicates that the reset is complete.</p> <p>Adjust the distance and angle of the barcode reader to focus on printed barcode. Avoid reflections or other sources of light interference.</p> <p>Try reading another barcode.</p> <p>Clean barcode reader lens.</p> <p>The <b>PrisMax</b> provides drop down selection menus to allow the user to continue if the barcode reader fails to read.</p> |

| Description  | Possible cause   | Corrective action  |
|--|--|--|
| Discolored effluent, fluid tinged pink or red.                     | Effluent contains red blood cells below blood leak detector (BLD) limit. | Send effluent sample to laboratory for analysis. If sample is free of red blood cells, continue treatment.<br><br>If blood is present in the effluent line, replace the set.           |
|  | Hemolysis due to occlusion or drugs being delivered.                     | Verify that there are no kinks in the access or return lines. Verify that the correct clamps are open for the therapy in use, especially for the access (red) and return (blue) lines. |
|  | Patient disease state.   | Change set. If condition recurs with new set, consult physician to assess patient disease state.   |
| Leaks from set connections.  | Loose connections in disposable set.                                     | Inspect and tighten set connections as needed.<br><br>If leaks recur, change set.  |
| Pressure reading is unexpectedly high or low, but no alarm occurs. | Pressure pod is incorrectly positioned.                                  | Perform a self test (tap the <b>Tools</b> button, and then select <b>Self Test</b> ).  |

## Power failure

The **PrisMax** system continues operation in case of AC power loss or temporary power cord disconnection.



### CAUTION!

If the battery is depleted and AC power is not available, closely monitor the patient and manually terminate the treatment (See "About manually terminating a treatment", page 87).

A power failure occurs due to loss of AC power, blown fuses in the power entry module, or because the power cord is not connected to AC power. The system can start only if AC power or sufficient battery

power is present at startup. If AC power fails after the control unit has started, the system response depends on the battery voltage.

If battery voltage is sufficient when power failure occurs:

- A battery icon appears to indicate that the control unit is on battery power.
- A loss of AC power message appears, and treatment continues. When fully charged, the battery pack can support full system operation for at least 30 minutes. Therapy can continue, but if AC power does not return, treatment should be discontinued and stopped per hospital/clinic policy.
- If AC power is not restored and battery voltage gets low, a low battery alarm occurs. End the treatment, select whether to return blood to patient, and follow the onscreen instructions.

If the battery is depleted when power failure occurs:

- The Total Loss of Power alarm is triggered.
- Immediately discontinue treatment, and proceed to End mode.
- Follow the onscreen instructions to return blood and disconnect the filter set.

## Fluid leakage



### **NOTE!**

In case of leakage from the pressure pod diaphragm (access, effluent and filter) or the monitor line, quarantine the device at the end of the treatment. Label the device as out of service until it is checked, cleaned, and disinfected by a qualified service technician.

Follow these steps in the unlikely event of a blood/infusion solution leakage from a pod diaphragm or if blood reaches the fluid barrier of the monitor line.

Table **Corrective steps for fluid leakage**

|  |   |
|--|---|
| Blood leakage from the access or filter pressure pod diaphragm.                        | <p>End treatment.</p> <p>Label to indicate that control unit is out of service and place in a quarantine location.</p> <p>Contact an authorized service technician.</p> |
| Blood or infusion fluid reaches fluid barrier above deaeration chamber on return line. | Change set.   |
| Blood or infusion fluid passes through fluid barrier and reaches return pressure port. | <p>End treatment.</p> <p>Label to indicate that control unit is out of service and place in a quarantine location.</p> <p>Contact an authorized service technician.</p> |
| Liquid leak at luer connection.  | <p>Tighten luer connection.</p> <p>Change set if leak persists.</p>   |
| Leak at sample site or peristaltic pump tubing.  | <p>End treatment.</p> <p>Change set.</p>  |

## Air removal

The **PrisMax** system automatically monitors the deaeration chamber during operation and adjusts the fluid level automatically up and down, and warn the user if the chamber needs to be adjusted up when the Liquid Level Sensor (LLS) is active. If the deaeration chamber cannot remove all the air from the return line before air reaches the Air Bubble Detector (ABD), the system stops all pumps, warns of air in blood, and closes the return clamp. Follow the onscreen instructions.

If air is still present, follow these steps to remove air manually. If the alarm reoccurs, dock the alarm, and continue with the manual air removal.

Required equipment:

- Syringe with 20 gauge needle.

Follow these steps to remove air from blood manually:

### Manual approach

1. Clean the blue sample site on the return line.
2. Insert a 20 gauge needle with syringe into the blue sample site (return line).
3. Aspirate air/blood until the return pressure reaches a negative value (0 to -100 mmHg).
4. Remove the needle.
5. Tap the **Open Clamp** button to remove air and draw blood from patient into the return line/deaeration chamber.
6. Verify that the alarm stops and the return line clamp opens. Air in the return line is drawn into the chamber monitor line and automatically eliminated from the set through the return pressure port. Blood is also drawn from the patient into the return line and deaeration chamber.

## Use with cardiac monitor



### CAUTION!

When starting a **PrisMax** treatment, observe the cardiac monitor before and after the blood pump starts to verify that no artifact appears. If cardiac dysrhythmia occurs, stop the blood pump and reassess cardiac rhythm before proceeding.

The electrically-isolated peristaltic pumps on the control unit can produce electrostatic charges in the disposable set. These electrostatic charges are not hazardous to the patient, but can appear as an artifact on a cardiac monitor.

To minimize electrical interference:

- Always install the discharger ring in its guide before connecting a patient to the disposable set.
- Carefully follow the ECG instructions regarding use of specific electrodes with low contact impedance and correct electrode application, including appropriate N electrode placement.



## Chapter 4

# General information

|   |            |
|---|------------|
| <b><u>About the general information</u></b>       | <b>173</b> |
| <b><u>Warnings, cautions and notes</u></b>        | <b>174</b> |
| <b><u>Indication for use</u></b>                  | <b>182</b> |
| <b><u>Contraindications</u></b>                   | <b>183</b> |
| <b><u>Keywords used in this manual</u></b>        | <b>183</b> |
| <b><u>Responsibility and disclaimer</u></b>       | <b>184</b> |
| <b><u>Symbols</u></b>                             | <b>185</b> |
| <b><u>Color coding</u></b>                        | <b>189</b> |
| <b><u>Certification marks</u></b>                 | <b>191</b> |
| <b><u>Installation, service and transport</u></b> | <b>191</b> |
| <b><u>Disposal</u></b>                            | <b>192</b> |



# General information

## About the general information

The **PrisMax** ("PrisMax", page 174) includes the control unit, a disposable set (tubing and filter), sterile solutions and eventually other approved hardware or disposable accessories. The physician prescribed therapy determines which set, solutions and accessories are used.

**NOTE!**

This section is an introduction: Read the entire manual before operating the **PrisMax**.



Figure PrismaMax

## Warnings, cautions and notes



### **WARNING!**

A warning alerts the reader about a situation which, if not avoided, could result in an adverse reaction, injury or death.

**CAUTION!**

A caution alerts the reader about a situation which, if not avoided, could result in minor or moderate injury to the user or patient or damage to the equipment or other property.

**NOTE!**

Notes are added to give more information.

**General****WARNING!**

Carefully read this operator's manual and instructions for the disposable sets, solutions and accessories before operating this device. Before first use, verify correct system operation.

**WARNING!**

To help ensure patient safety, perform all operation, maintenance, and calibration procedures for the **PrisMax** system according to this operator's manual, onscreen instructions, service manual, and disposable set, solution and accessory instructions. All procedures must be performed by authorized clinicians or service technicians.

**WARNING!**

To avoid the risk of electric shock, only connect this equipment to a supply mains with protective earth (ground).

**WARNING!**

Perform and monitor therapies using the **PrisMax** system under physician supervision.

**WARNING!**

The **PrisMax** system may not be able to detect all disconnections from blood access and return connections, which can result in blood loss.

**WARNING!**

Follow hospital procedures for the proper disposal of the used disposable set and fluid bags, and accessories, in accordance with local regulations.

**WARNING!**

Training is required prior to operating this device or its approved accessories. Do not use the **PrisMax** system unless the appropriate training has been completed.

**CAUTION!**

Federal law restricts this device to sale by or on the order of qualified medical personnel.

**CAUTION!**

Follow all applicable regulatory restrictions on therapies, disposable sets, solutions, or other accessories. Not all treatments are available in all locations. All treatments administered by the **PrisMax** must be prescribed by qualified medical personnel.

**CAUTION!**

The **PrisMax** control unit weighs approximately 70 kg (154 lb). At least two people are required to lift it out of the shipping carton. Handle the unit carefully.

**CAUTION!**

Do not use the **PrisMax** control unit near flammable gas, or a flammable anesthetic mixture with air, oxygen, or nitrous oxide.

**CAUTION!**

Release the brakes on all wheels and use the handles (not the syringe pump, scales or the filter of a loaded disposable set) to move the control unit.

**CAUTION!**

The hospital is solely responsible for connecting a remote alarm to the **PrisMax** system and verifying the remote alarm operates correctly. A remote alarm is not intended to substitute for direct, periodic clinical observation.

**CAUTION!**

Use aseptic techniques according to hospital policy.

**CAUTION!**

Use sterile sets and aseptic technique to prevent cross-infection between patients.

**CAUTION!**

When handling disposable sets, always take adequate precautions to prevent exposure to or transmission of HIV, hepatitis virus, or other infectious agents.

**CAUTION!**

Refer to the set and solution instructions for storage and temperature specifications.

**CAUTION!**

Variations in room temperature of  $\pm 10$  °C ( $\pm 18$  °F) or more can cause the scales to become inaccurate.

**NOTE!**

The **PrisMax** system has been tested and validated for use with accessories, disposables and solutions described in this manual. BAXTER does not accept any responsibility or liability for use of non-approved accessories, disposables or solutions, or for any use that is not in accordance with onscreen instructions, disposable set instructions, or this manual.

**NOTE!**

Dispose of the device shipping carton, foam packing, and other packaging material according to local regulations.

**NOTE!**

Do not dispose of electro-medical equipment with municipal waste. Some device components (display, batteries, circuit boards, etc.) may contain toxic substances that are harmful to the health of living organisms and the environment. Follow all applicable environmental regulations for correct disposal.

**NOTE!**

The system sounds an audible alarm within 5 seconds of a complete loss of power.

**NOTE!**

Never insert fingers or any object into the return line clamp, pinch valves, or motors.

**NOTE!**

The device remains stable when pushed or pulled over steps as high as 10 mm (0.4 in). For larger steps, pull (don't push) the device.

**NOTE!**

If applicable, the frangible pins of Baxter bags have contrasting, easily visible colors.

**NOTE!**

**PrisMax** disposable filter set and accessories are single use only. Do not attempt to reuse or re-sterilize.

**NOTE!**

Discard and destroy the **PrisMax** disposable filter set and accessories after a single use, following appropriate guidelines for disposal of potentially contaminated material.

**NOTE!**

A potential equalization terminal is connected to the monitor chassis. It can be connected to corresponding terminals on other equipment to eliminate potential differences. Do not use this terminal for additional protective grounding.

**Therapy****WARNING!**

It is the hospital's responsibility to select treatment parameters. It is the responsibility of the physician to explicitly confirm these parameters are appropriate for each patient before treatment starts.

**WARNING!**

To help ensure the minimization of treatment delay and potential blood loss, all removable components, including bag handles, and the blood return tool, must remain with the **PrisMax** system at all times.

**WARNING!**

Because hypotension can be a complication of renal replacement therapy, it is important to monitor patient blood pressure according to hospital policy.

**WARNING!**

Extremely negative pre-pump arterial pressure can impact the range and accuracy of the flow of the pump(s) and the inlet and outlet pressure range over which this accuracy is maintained, adversely affecting treatment efficacy.

**WARNING!**

Follow hospital procedure to ensure that the access and return catheters (cannulas) is properly secured to the skin.

**WARNING!**

Closely monitor connection of disposable accessories to other system components (syringe, set, solution).

**CAUTION!**

Operator must monitor the set for kinks.

**CAUTION!**

To help ensure correct fluid balance, periodically measure patient weight.

**CAUTION!**

Use the **PrisMax** system on patients weighing 8 kg (17.6 lb) or more. A higher minimum patient weight limit may apply to the disposable set (refer to the applicable instructions).

**CAUTION!**

Monitor for patient hypothermia according to hospital policy, particularly when increasing exchange volumes.

**CAUTION!**

Use only solutions of an appropriate composition and temperature that conform to the physician prescription. Before use, ensure solutions or fluids are free of precipitates or other particulate matter.

**CAUTION!**

To avoid flow errors, do not allow fluid bags to swing or become obstructed or partially supported by a foreign object on the scale.

**CAUTION!**

Renal replacement therapy with high-permeability hemofilters may reduce the concentration of therapeutic drugs in the patient's blood. Consult the drug manufacturer's literature for more information and consider monitoring drug concentration to ensure an appropriate therapeutic dosage. The possible removal of other water-soluble compounds (for example, vitamins or trace elements) also requires clinical consideration.

**CAUTION!**

Use a 21-gauge (or smaller diameter) needle to obtain blood or fluid samples. Using a larger needle can cause a hole in the sample sites, resulting in blood loss or air embolism.

**NOTE!**

Due to low blood flow rates, extended treatment times, and other factors, the disposable set is susceptible to the risk of coagulation within the flow path. Ensure the blood flow rate is greater than or equal to the minimum rate specified for the set in use.

**NOTE!**

Monitor the patient's blood chemistry and vital data periodically and as needed according to hospital policy.

**NOTE!**

For accurate blood chemistry results, it is important to collect blood samples from the correct set site and to consider the dilution effect of infusions (for example, the effect of the PBP infusion rate on an access site blood sample). Allow several minutes after an infusion before taking a blood sample.

**NOTE!**

Avoid moving the control unit when a blood warmer is installed. If the control unit must be moved, place the warmer in a transport position before moving.

**NOTE!**

The **PrismaTherm II** blood warmer extension line causes a pressure drop between the filter outlet and deaeration chamber, which is proportional to blood flow rate and is also dependent on blood hemoconcentration at the filter outlet. See the **PrismaTherm II** blood warmer's instructions for more information on its effect on filter pressure drop and TMP measurements.

**NOTE!**

The **TherMax** blood warmer disposable causes a pressure drop between the filter outlet and deaeration chamber, which is proportional to blood flow rate and is also dependent on blood hemoconcentration at the filter outlet

**Service/installation****WARNING!**

Use only the **PrisMax** hospital-grade power cord to connect the control unit to the hospital electrical outlet.

**WARNING!**

To avoid the possibility of electromagnetic disturbance to the device, do not use a cellular phone or other radio frequency equipment within a short distance of the **PrisMax** system. For more specific information see "Guidelines and manufacturer's declaration of electromagnetic emissions and immunity", page 329.

**WARNING!**

All electrical installations must comply with all applicable local electrical codes and manufacturer specifications.

**WARNING!**

Do not perform any service or maintenance while the device is in use on a patient.

**CAUTION!**

Service mode is intended for use by authorized service technicians only. If an operator inadvertently enters Service mode, cycling power will return the **PrisMax** system to normal operation.

**CAUTION!**

Do not use any type of lubricant on the internal or external components of the **PrisMax** system, disposable set or accessories. Only authorized service technicians can apply lubricants to machine components. Improper use of lubricant can adversely affect device performance.

**CAUTION!**

The fluid volume accuracy of the **PrisMax** system depends on accurate scale (using the correct weights) and pressure calibration. All calibrations must be performed by an authorized service technician as described in the service manual.

**NOTE!**

If the **PrisMax** system is damaged or internal components are exposed, contact service. Do not use until an authorized service technician has verified correct system operation.

**NOTE!**

The correct installation of a medical electrical system requires that each system component is individually connected to mains power with protective ground, and Baxter strongly advises against using multiple portable socket-outlets. However, any multiple portable socket-outlets used must comply with the IEC 60601-1-1 standard and must not be placed on the floor.

## Indication for use

The PrisMax control unit is intended for:

- Continuous Renal Replacement Therapy (CRRT) for patients weighing 20 kilograms or more with acute renal failure and/or fluid overload.
- Therapeutic Plasma Exchange (TPE) therapy for patients weighing 20 kilograms or more with diseases where removal of plasma components is indicated.

All treatments administered via the PrisMax control unit must be prescribed by a physician.

**WARNING!**

Use only fluids designed for intravenous operations and are approved for CRRT/TPE usage. Do not use fluids intended for any other usage like enteral feedings/lipids or cytotoxic drugs.

## Contraindications

There are no known absolute contraindications to continuous renal replacement therapies.

There are no known contraindications to Therapeutic Plasma Exchange.

There are no known contraindications to Hemoperfusion.

For the following conditions a careful assessment of the individual risk/benefit ratio has to be made by the treating physician (relative contraindications).

- Inability to establish vascular access.
- Severe hemodynamic instability.
- Known hypersensitivity to any component of the Prismaflex disposable set.

## Keywords used in this manual

**Applied part**

An **applied part** is any part of the **PrisMax** system that physically contacts the patient in normal use. For example, disposable set lines are applied parts.

**Authorized service technician**

An **authorized service technician** is a Baxter-trained and certified service technician.

**Filter**

Depending on the therapy in use, **filter** indicates hemofilter or dialyzer.

**Manual**

The term **manual** refers to this manual unless specified otherwise.

**Operator**

An **operator** is an appropriately trained and qualified member of clinical staff who interacts with the **PrisMax** system. Once the operator reads through and understands the training material, the operator is approved to use the

|                                 |  |
|---------------------------------|--|
| <b>Responsible organization</b> | <b>PrisMax</b> system. The operator works within one meter from the front of the control unit. The <b>responsible organization</b> identifies, analyzes, and controls potential risks that could occur when using the machine. |
| <b>Screens</b>                  | <b>Screens</b> are identified by title. For example, Setup screen or Therapy screen.   |
| <b>Total weight</b>             | The <b>total weight</b> of the machine is the combined weight of the control unit and the maximum load of accessories, disposables, and solutions.   |
| <b>Training material</b>        | This manual is the primary <b>training material</b> for clinicians to operate the machine.   |

## Responsibility and disclaimer

Baxter accepts responsibility for the safety, reliability, and performance of this equipment only under the following circumstances:

- Any modifications to the equipment are authorized in writing by Baxter and carried out by an authorized service technician.
- The electrical installation for powering the equipment complies with all applicable local electrical codes and requirements including applicable IEC requirements.
- The equipment is used in accordance with this manual.
- The equipment is maintained by an authorized service technician.

A service manual is available upon request, including all necessary circuit diagrams, calibration instructions, and service information.

Information about the limits of performance specifications is available upon request.

This manual includes references to accessories and disposables for use with the machine. For more information about accessories, see . The **PrisMax** system has been tested and validated for use with these accessories and disposables. Baxter does not accept any responsibility or liability for use of accessories or disposables other than those specified in this manual, or in the event any specified accessory or disposable is not used in accordance with this manual. This also extends to onscreen instructions, and the instructions for use (IFUs) that accompany those accessories and disposables.



Baxter cannot be responsible or liable for any damage due to service performed by unauthorized service technicians.







Under no circumstances is Baxter liable for any indirect, incidental, special, or consequential damage of any kind, and liability is limited solely to repair or replacement.





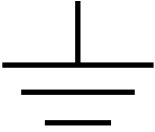

## Symbols

If applicable, the following symbols appear on or near the serial number label or other permanently affixed labels on this device, or on device packaging.

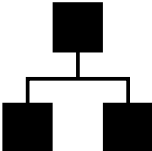

Table **Symbols and definitions**

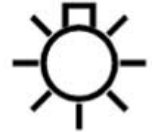
| Symbol  | Definition   |
|---|--|
|    | <p>Type CF equipment applied part, defibrillation-proof per IEC 60601-1. Type label on front panel indicates device classification.</p>  |
|   | <p>A caution alerts the operator/reader about a situation which, if not avoided, could result in minor or moderate injury to the user or patient or damage to the equipment or other property.</p> |
|  | <p>Follow instructions for use. Colors are blue and white. This symbol complements the triangle warning symbol.</p>  |
| <p><b>Rx Only</b></p>   | <p>Caution: Federal (USA) law restricts this device to sale by or on the order of a physician.</p>   |
| <p><b>IPX1</b></p>  | <p>Equipment is protected against vertically falling water drops.</p>  |

| Symbol  | Definition   |
|---|--|
|    | Device requires alternating supply current.  |
|    | Conductors carrying high voltage and is hazardous if contacted.  |
|    | Functional earth connection  |
|    | Protective earth connection  |
|  | Connection point for potential equalization conductor. The terminal connects to the chassis and should be connected to corresponding terminals on other equipment to remove potential differences. |
|  | Fuse   |
|  | Date of manufacture. The year is written using four digits.  |

| Symbol  | Definition   |
|---|--|
|    | Manufacturer information   |
|    | Catalog number   |
|    | Serial number  |
|    | Ethernet port  |
|  | Serial communication port. The symbols shows the function of each port:                          |
|   |  Service port |
|   | Blood warmer port  |
|   | Alternative remote alarm connection  |
|  | Remote alarm connection  |
|  | Product conforms to RoHS Directive 2011/65/EU.   |



| Symbol   | Definition  |
|--|---|
|   | <p>Equipment contains dangerous substances, and must not be disposed of with other municipal waste. Recycle according to applicable regulations.<br/>Equipment sold after 13 August 2005.</p> |
|   | <p>Never tilt device more than five degrees from the floor. Background color is yellow. Apply this label to the warmer holder before use.</p>   |
|   | <p>Recycle cardboard</p>  |
|   | <p>Fragile – handle with care</p>   |
|   | <p>Keep dry</p>   |
| <p data-bbox="181 1221 287 1251"><b>100 kg max</b></p>  | <p>Maximum stacking load permitted on the transport package is 100 kg.</p>  |
|   | <p>This end up</p>  |

| Symbol  | Definition   |
|---|--|
|  | Humidity limits: upper and lower limits in %.  |
|  | Temperature limits: upper and lower limits in degrees Celsius (°C) or Fahrenheit (°F). |

## Color coding

Scale LEDs: Disposable set lines correspond to scales and associated pumps:

Table **Color coding and meaning**

| Symbol  | Meaning   |
|---|---|
|  | PBP scale (white triangle)  |
|  | Dialysate scale (green square). Replacement 2 scale for CVWH therapy. |
|  | Replacement scale   |

| Symbol  | Meaning   |
|---|---|
|    | Effluent scale (yellow circle)                                      |
|    | Access line (red-striped)   |
|    | PBP line (white-striped)  |
|    | Dialysate line (green-striped). Replacement 2 line for CVH therapy. |
|  | Replacement line (purple-striped)                                   |
|  | Effluent line (yellow-striped)                                      |
|  | Return line (blue-striped)  |

# Certification marks

Table Certification marks

| Symbol  | Meaning   |
|---|---|
|  | <p>The CE mark indicates that the <b>PrisMax</b> system conforms to the requirements in the EC Council Directive 93/42/EEC of 14 June, 1993 concerning medical devices and all applicable EU Directives. It also indicates that the notified body TÜV SÜD (No. 0123) has approved the Quality Management System. The CE mark is only valid for the device. Disposables and any accessories specified for use with the device have their own CE marks.</p> |

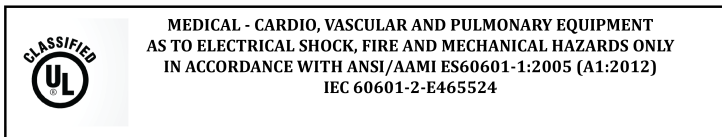

## Installation, service and transport

Please note that the **PrisMax** system must be setup by an authorized service technician. For installation information, see the service manual for the **PrisMax** system. For technical assistance, contact your local Baxter representative.



### CAUTION!

Do not connect a patient to the **PrisMax** system during the installation test. Be sure the test is conducted using a container of water in substitution of a patient.

**CAUTION!**

Position the control unit so the connection to AC (mains) power is accessible.

## Disposal

**Disposal of packaging material**

Dispose of the **PrisMax** shipping carton, foam packing, and other packaging material according to local regulations.

**Disposal of discarded equipment**

Discarded electro-medical equipment must be collected separately from municipal waste to guarantee ecologically correct disposal and to avoid releasing possible pollutants into the environment. Some components of the **PrisMax** control unit may contain toxic substances which, if released into the environment, pose a risk to the health of living organisms and the environment.

**Disposal of waste batteries**

According to Directive 2006/66/EC and RAEE Directive concerning batteries, the manufacturer must provide instructions for replacing and removing batteries in a safe and environmentally friendly manner. Discarded batteries must be separately collected from normal waste. Always check local regulations for correct environmental disposal.

## Chapter 5

# Therapies

|   |            |
|---|------------|
| <b>About the therapies</b>                              | <b>195</b> |
| <b>Abbreviations</b>                                    | <b>196</b> |
| <b>Pressure handling (all therapies)</b>                | <b>197</b> |
| About pressure handling (all therapies) ...             | 197        |
| Access pressure ...                                     | 197        |
| Filter pressure ...                                     | 200        |
| Return pressure ...                                     | 202        |
| <b>Continuous Renal Replacement Therapies (CRRT)</b>    | <b>205</b> |
| About Continuous Renal Replacement Therapies (CRRT) ... | 205        |
| CRRT settings ...                                       | 206        |
| SCUF therapy ...  | 207        |
| CVVH therapy ...  | 208        |
| CVVHD therapy ...                                       | 209        |
| CVVHDF therapy ...                                      | 210        |
| Replacement solution ...                                | 212        |
| CRRT disposable sets ...                                | 213        |
| Patient fluid balance ...                               | 215        |
| CRRT software calculations ...                          | 217        |

## **Therapeutic Plasma Exchange (TPE) 220**

---

**About Therapeutic Plasma Exchange (TPE) ... 220**

**TPE flowchart ... 222**

**TPE and anticoagulation methods ... 223**

**TPE disposable sets ... 223**

**Specific functions in TPE ... 223**

**Therapy operation in TPE ... 226**

# Therapies

## About the therapies

The **PrisMax** system draws blood from the patient through a filter in the disposable set, and then back to the patient. The treatment takes place as blood passes through the filter. The treatment removes fluid, clears solutes, or does both depending on the therapy.

The user selects the therapy during setup. The following therapies are available:

### **CRRT**

Continuous renal replacement therapies include the following therapies:

- Slow continuous ultrafiltration (SCUF)
- Continuous veno-venous hemofiltration (CVVH)
- Continuous veno-venous hemodialysis (CVVHD)
- Continuous veno-venous hemodiafiltration (CVVHDF)

### **TPE**

Therapeutic Plasma Exchange

Some therapies might not be available in some countries. Therapy availability is subject to regulatory approval. Follow local regulations and restrictions.

# Abbreviations

The software calculations in this section use the following abbreviations.

|                              |  |
|------------------------------|--|
| <b>BW</b>                    | Patient body weight (kg)   |
| <b>D<sub>CRRT-eff</sub></b>  | Effluent dose (ml/kg/h)  |
| <b>D<sub>CRRT-UFR</sub></b>  | Ultrafiltration rate (UFR) dose (ml/kg/h)  |
| <b>FF</b>                    | Filtration fraction (%)  |
| <b>Hct</b>                   | Hematocrit (%) (default 30%)   |
| <b>Hct<sub>post</sub></b>    | Post-filter hematocrit   |
| <b>P<sub>eff</sub></b>       | Effluent pressure (mmHg)   |
| <b>P<sub>fil</sub></b>       | Filter pressure (mmHg)   |
| <b>ΔP<sub>fil</sub></b>      | Filter pressure drop (mmHg)  |
| <b>PRE%</b>                  | Predilution %  |
| <b>PRE%<sub>tot</sub></b>    | Total predilution (%)  |
| <b>P<sub>ret</sub></b>       | Return pressure (mmHg)   |
| <b>Q<sub>b</sub></b>         | Blood flow rate (ml/h)   |
| <b>Q<sub>dial</sub></b>      | Dialysate solution flow rate (ml/h)  |
| <b>Q<sub>eff</sub></b>       | Effluent flow rate (ml/h)  |
| <b>Q<sub>extin</sub></b>     | External fluid input flow (ml/h)   |
| <b>Q<sub>extout</sub></b>    | External fluid output flow (ml/h)  |
| <b>Q<sub>inlet</sub></b>     | Combined rate of blood pump rate, systemic syringe rate and pre replacement rate (ml/min)                                      |
| <b>Q<sub>makeup</sub></b>    | An automatic flow to make up patient fluid removed calculated to compensate for treatment pauses due to bag changes and alarms |
| <b>Q<sub>pbp</sub></b>       | PBP flow rate (ml/h)   |
| <b>Q<sub>pfr</sub></b>       | Patient fluid removal (PFR) flow rate (ml/h)   |
| <b>Q<sub>plasma</sub></b>    | Plasma water flow rate at patient access (ml/h)  |
| <b>Q<sub>plasma_in</sub></b> | Filter inlet plasma flow rate (ml/h)   |
| <b>Q<sub>ppl</sub></b>       | Patient Plasma Loss (PPL) flow rate (ml/h)   |
| <b>Q<sub>pfl</sub></b>       | Prescribed patient fluid loss flow rate (ml/h)   |
| <b>Q<sub>pre</sub></b>       | Pre-infusion flow rate (ml/h)  |
| <b>Q<sub>rep</sub></b>       | Total (pre, post, or pre-post) replacement solution flow rate (ml/h)   |
| <b>Q<sub>rep_post</sub></b>  | Post-filter replacement flow rate (ml/h)   |
| <b>Q<sub>rep_pre</sub></b>   | Pre-filter replacement flow rate (ml/h)  |
| <b>Q<sub>syr</sub></b>       | Syringe flow rate (any anticoagulation method) (ml/h)  |
| <b>Q<sub>uf</sub></b>        | Ultrafiltration flow rate (ml/h)   |
| <b>T</b>                     | Treatment time (h)   |
| <b>TMP</b>                   | Transmembrane pressure (mmHg)  |

|                        |   |
|------------------------|---|
| $V_{\text{dial}}$      | Cumulative dialysate solution pumped over the specified time period (ml)    |
| $V_{\text{eff}}$       | Cumulative effluent bag volume measured over the specified time period (ml) |
| $V_{\text{exch(tot)}}$ | Total replacement volume (ml)   |
| $V_{\text{efftgt}}$    | Target effluent volume (ml)   |
| $V_{\text{pbp}}$       | Cumulative PBP solution volume pumped over the specified time period (ml)   |
| $V_{\text{ppl}}$       | Patient plasma volume removed over the specified time period (ml)           |
| $V_{\text{ppl(tgt)}}$  | Expected volume of plasma loss based on prescribed treatment duration (ml)  |
| $V_{\text{pfr}}$       | Patient fluid volume removed over the specified time period (ml)            |
| $V_{\text{rep}}$       | Cumulative replacement solution pumped over the specified time period (ml)  |
| $V_{\text{syr}}$       | Cumulative syringe solution pumped over the specified time period (ml)      |

## Pressure handling (all therapies)

### About pressure handling (all therapies)

This section describes how the **PrisMax** system handles access, filter, and return pressures.

### Access pressure

The access line ( "Access (red) line", page 198) includes the line from the patient to the filter. The access pressure sensor monitors changes in the access pressure pod. The sensor is placed behind the pressure pod housing. The automatic reposition system (ARPS) checks that the access pressure pod works correctly at least every two hours.

The access line pressure depends on the following factors:

- patient
- set type

- access line connection
- flow rates

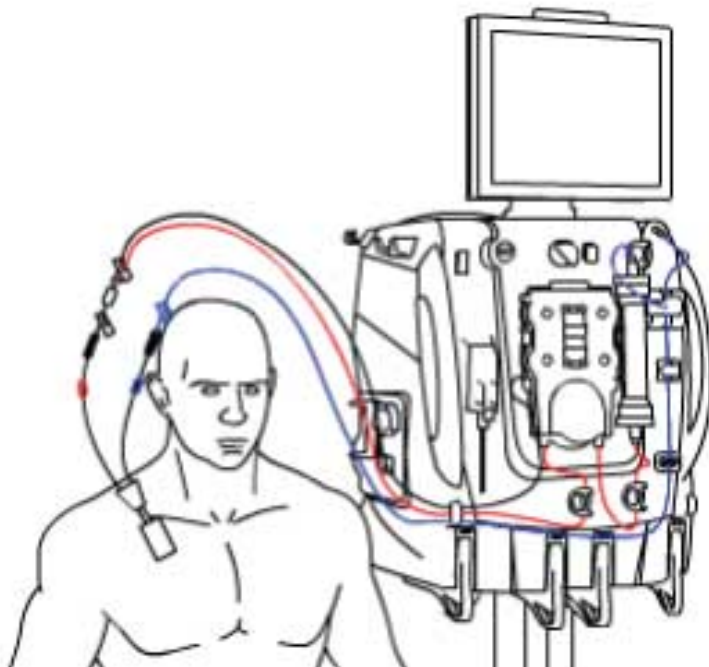

Figure Access (red) line

Normal access pressure is negative or positive, depending on the access connection. If a central venous catheter is in use, access pressure is negative. If other connections are in use, such as an external blood access device or arteriovenous (A-V) fistula, the access pressure is positive.

During operation, the software calculates a reference access pressure value, called the operating point ( "Access Pressures", page 199). The software continually compares the current access pressure with the operating point to detect changing pressure conditions in the set. The normal operating range is the operating point  $\pm 50$  mmHg for flows of 200 ml/min or less, and  $\pm 70$  mmHg when flow is higher than 200 ml/min.

The pressure operating points are first calculated shortly after the control unit enters Therapy mode, when the pumps reach the target speed and the blood flow through the set is stable. The software updates the pressure operating points at the following events:

- blood flow rate (BFR) change
- blood pump restart
- Pressure alarm clearing
- pinch valve position change
- self-test

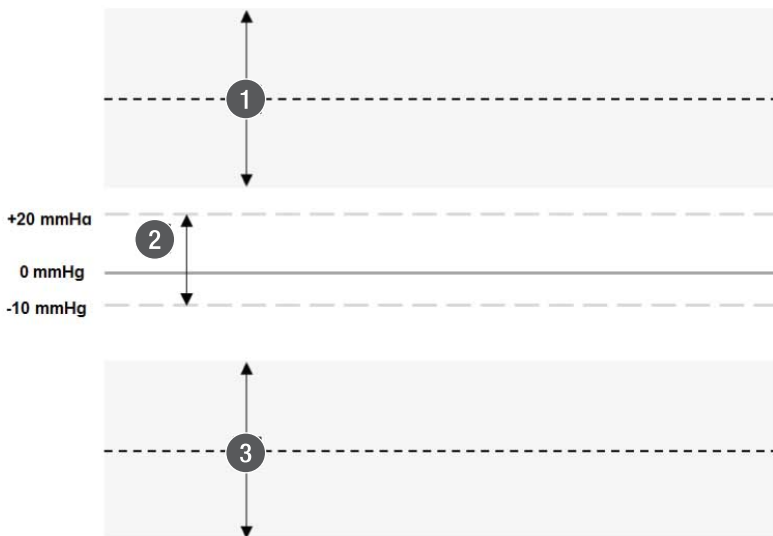

Figure Access Pressures

1. Access pressure operating point and normal operating range, operating point  $\pm 50/70$  mmHg, for positive access pressures.
2. Check access range (-10 to 20 mmHg).
3. Access pressure operating point and normal operating range, operating point  $\pm 50/70$  mmHg), for negative access pressures.

Table Pressure points and operating ranges

| Current pressure point | Lower limit of access pressure operating range                  | Upper limit of operating range                                |
|------------------------|---|---|
| -10 mmHg or lower      | Maximum of the operating point -50 mmHg/-70 mmHg, or -250 mmHg. | Minimum of the operating range +50 mmHg/70 mmHg, or -10 mmHg. |
| -10 mmHg and + 20 mmHg | -10 mmHg  | +20 mmHg  |
| Above +20 mmHg         | Minimum of the operating points +50/ 70 mmHg, or 450 mmHg.      | Maximum of the operating point -50/70 mmHg, or +20 mmHg.      |

## Filter pressure

The filter pressure sensor monitors changes in the filter pressure ( "Filter and filter pressure pod", page 201). The sensor is placed behind the pressure pod housing. The filter pressure, measured just before the filter, is always positive and is the highest pressure in the set.

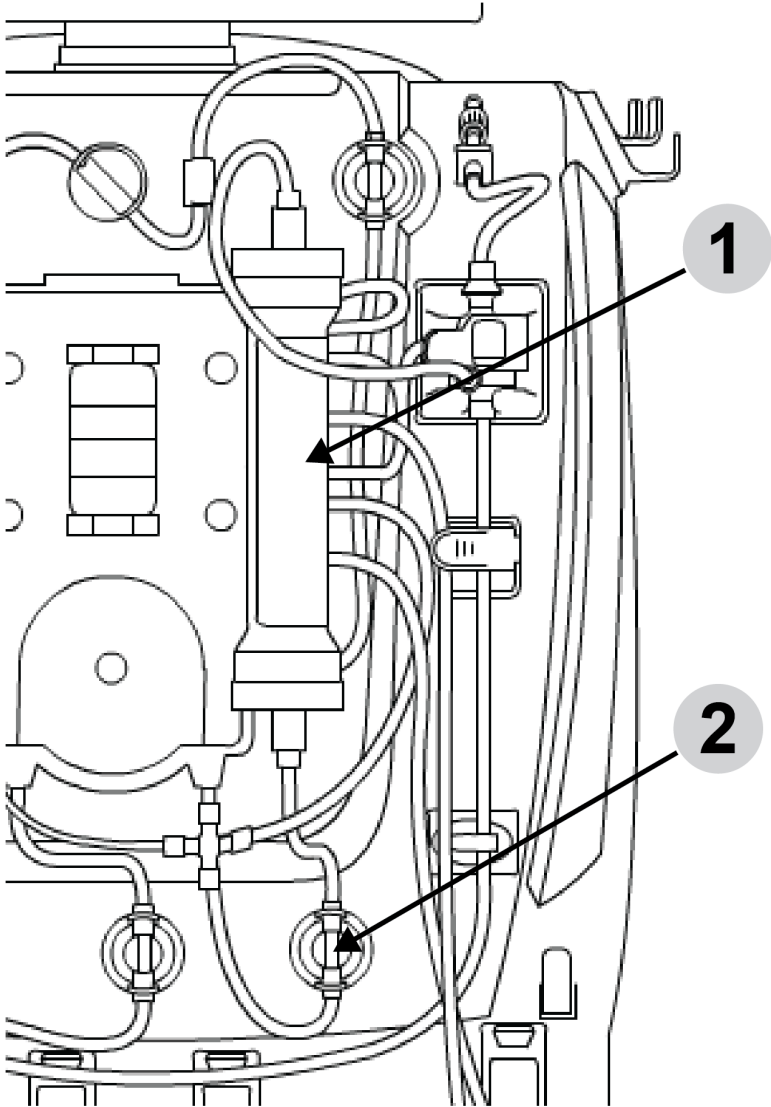

Figure Filter and filter pressure pod

1. Filter

2. Filter pressure pod (before filter inlet)

The filter pressure can indicate things like excessive blood flow rate (BFR) or a clotting of the filter membrane. The automatic reposition system (ARPS) checks that the filter pressure pod works correctly at least every two hours.

### **Filter pressure drop**

Filter pressure drop is calculated to determine the pressure conditions in the filter blood compartment. The filter pressure drop is calculated as follows:

$$\Delta P_{\text{fil}} = P_{\text{fil}} - P_{\text{ret}}$$

where:

- $\Delta P_{\text{fil}}$  is the filter pressure drop (mmHg)
- $P_{\text{fil}}$  is the filter pressure (mmHg)
- $P_{\text{ret}}$  is the return pressure (mmHg)

There is a hydrostatic pressure bias due to the pressure sensors being placed at different heights. The filter and return pressure readings are automatically corrected for this bias of -25 mmHg.

## Return pressure

The return line ( "Return (blue) line", page 203) includes the line from the filter outlet to the patient, the deaeration chamber and the return pressure port. The pressure sensor behind the return pressure port monitors changes in return pressure. In addition to individual patient characteristics, return line pressures depend on the set type and flow rates. The ARPS tests the return pressure for correct operation at least every 2 hours.

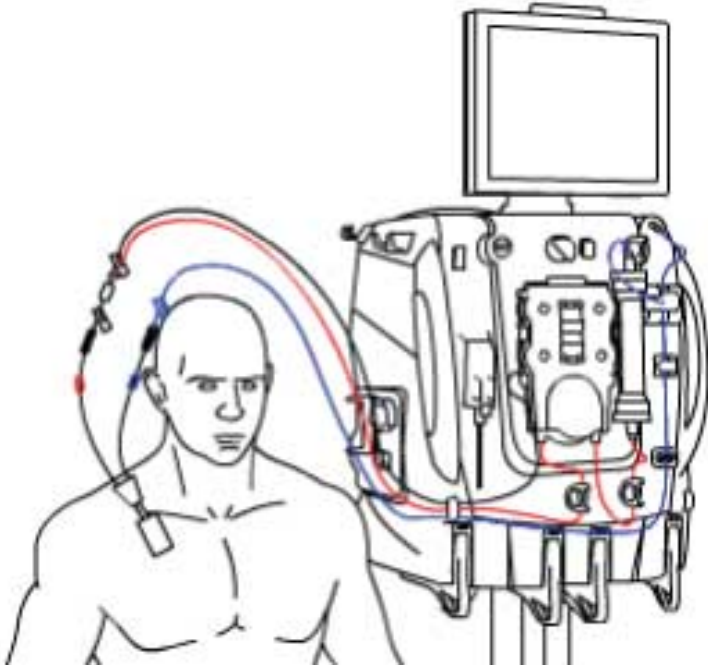

Figure Return (blue) line

Normal return pressure is always positive. During operation, software calculates a reference return pressure value, called the operating point ( "Return pressures", page 204). Software continually compares the current return pressure with the operating point to detect changing pressure conditions in the set. The normal default operating range is:

- $\pm 50$  mmHg when flow is 200 ml/min or less
- $\pm 70$  mmHg when flow is greater than 200 ml/min

The return disconnect pressure limit can be adjusted at the Change Screen under **Other Settings**. This makes it possible to manually set the lower disconnect alarm limit as close as possible to the return operating point.

The pressure operating points are first set shortly after the control units enter Therapy mode, when the pumps reach the target speed and the blood flow through the set is stable. The software updates the pressure operating points at the following events:

- Blood flow rate (BFR) change
- Blood pump restart

- Alarm reset
- Pinch valve position change
- Self test

Software includes fixed pressure limits to ensure patient safety. If a monitored pressure goes outside these limits, an alarm goes off. The return disconnect limit (RDL) is initially set to 10 mmHg. If return pressure drops below 10 mmHg, the system considers the return line to be disconnected. If the operating point changes, the return disconnect limit (RDL) may also change.

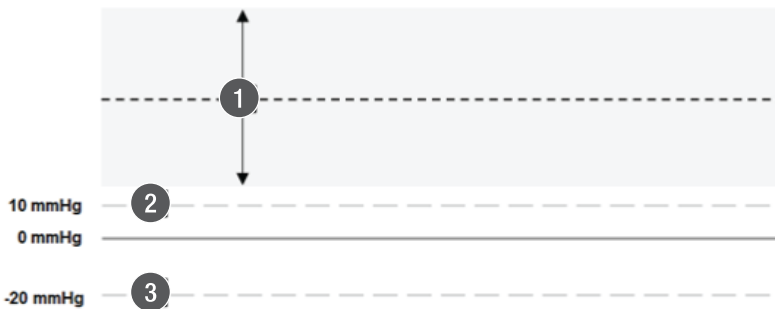

Figure Return pressures

1. Return pressure operating point and normal operating range (operating point  $\pm 50/70$  mmHg)
2. Return Disconnect Limit (RDL), initially set to +10 mmHg
3. Minimum Return Disconnect Limit (RDL), -20 mmHg

# Continuous Renal Replacement Therapies (CRRT)

## About Continuous Renal Replacement Therapies (CRRT)



### **WARNING!**

Monitor patient temperature to avoid hypo- or hyperthermia. Pay special attention when using high fluid exchange rates, when using a high capacity blood warmer, or when treating low body weight patients.



### **CAUTION!**

In all CRRT therapies, patient fluid removal takes syringe infusion volumes into account, regardless of the selected anticoagulation method.

CRRT therapies include:

- Slow continuous ultrafiltration (SCUF)
- Continuous veno-venous hemofiltration (CVVH)
- Continuous veno-venous hemodialysis (CVVHD)
- Continuous veno-venous hemodiafiltration (CVVHDF)

The terms **ultrafiltration**, **hemofiltration**, **hemodialysis**, and **hemodiafiltration** refer to the solute removal method:

### **Ultrafiltration**

Plasma water with solutes is drawn from the patient's blood across the semi-permeable membrane in the filter. The effluent pump automatically controls the ultrafiltration rate.

### **Hemofiltration**

Plasma water with solutes is drawn from the patient's blood across the semi-permeable membrane by means of ultrafiltration, while a replacement solution is infused into the blood flow path (pre-filter, post-filter, or pre- and post-filter). The replacement solution adds back

some or all of the removed fluid and required solutes. Unwanted solutes are not replaced, and their concentration decreases in the patient's blood. Solute removal is achieved by convection (solvent drag across the membrane).

### **Hemodialysis**

Unwanted solutes pass from the patient's blood across the semi-permeable membrane and into dialysate flowing through the fluid compartment of the filter. Because the concentration of unwanted solutes is lower in the dialysate than in the blood, the solutes diffuse from an area of greater concentration (blood) to an area of lesser concentration (dialysate solution). Solute clearance is achieved by diffusion.

### **Hemodiafiltration**

Hemodiafiltration uses hemodialysis and hemofiltration, and solute removal occurs by convection and diffusion. Dialysate solution is pumped through the fluid compartment of the filter. At the same time, the effluent pump controls ultrafiltration and a replacement solution is infused into the blood flow path.

## CRRT settings

Table CRRT settings

| CRRT therapy                     | SCUF | CVVH | CVVHD | CVVHDF   |
|----------------------------------|------|------|-------|----------|
| Blood flow                       | X    | X    | X     | X        |
| PBP flow                         | X    | X    | X     | X        |
| Dialysate flow                   | -    | -    | X     | X        |
| Replacement flow                 | -    | X    | -     | X        |
| Pre-/post-infusion               | -    | Pre% | -     | Pre/Post |
| Patient fluid removal (PFR) rate | X    | X    | X     | X        |

## SCUF therapy

SCUF therapy provides fluid removal and allows PBP infusion ("SCUF therapy setup", page 207).

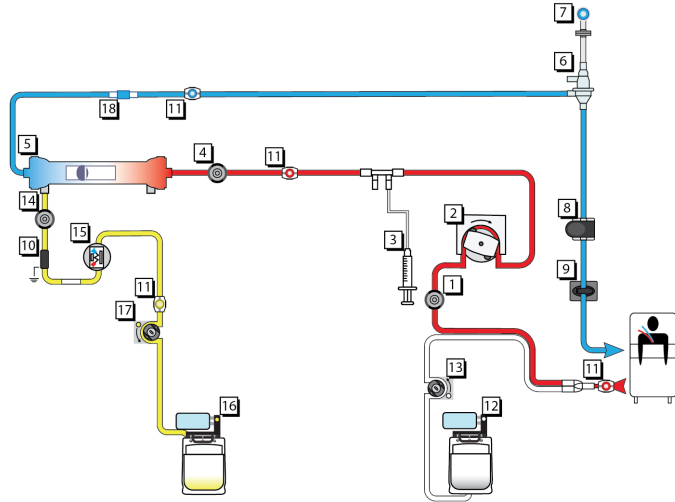

Figure SCUF therapy setup

- |                               |  |
|-------------------------------|--|
| 1. Access pressure sensor     | 2. Blood pump  |
| 3. Syringe pump               | 4. Filter pressure sensor                                    |
| 5. Filter                     | 6. Deaeration chamber  |
| 7. Return pressure sensor     | 8. Air Bubble Detector (ABD),<br>patient sensor, line sensor |
| 9. Return clamp               | 10. Discharger ring guide                                    |
| 11. Sample site               | 12. PBP scale  |
| 13. PBP pump                  | 14. Effluent pressure sensor                                 |
| 15. Blood Leak Detector (BLD) | 16. Effluent scale   |
| 17. Effluent pump             | 18. Blood warmer connection                                  |

## CVVH therapy

CVVH therapy provides hemofiltration with both pre and post-filter replacement infusion and allows for PBP infusion

("CVVH therapy setup", page 208).

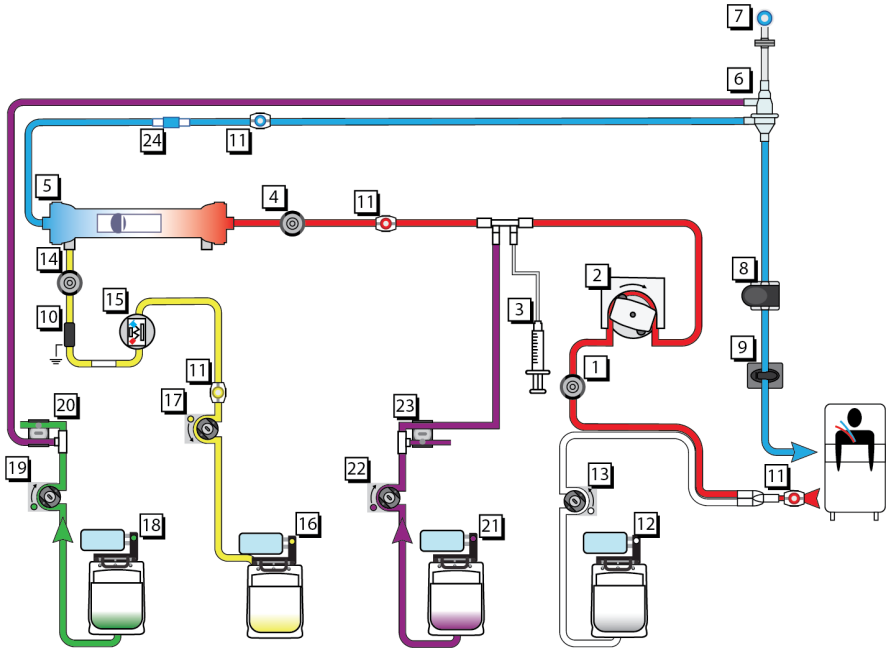

Figure CVVH therapy setup

- |                               |  |
|-------------------------------|--|
| 1. Access pressure sensor     | 2. Blood pump  |
| 3. Syringe pump               | 4. Filter pressure sensor                                    |
| 5. Filter                     | 6. Deaeration chamber  |
| 7. Return pressure sensor     | 8. Air Bubble Detector (ABD),<br>patient sensor, line sensor |
| 9. Return clamp               | 10. Discharger ring guide                                    |
| 11. Sample site               | 12. PBP scale  |
| 13. PBP pump                  | 14. Effluent pressure sensor                                 |
| 15. Blood Leak Detector (BLD) | 16. Effluent scale   |
| 17. Effluent pump             | 18. Replacement 2 scale                                      |
| 19. Replacement 2 pump        | 20. Upper pinch valve  |
| 21. Replacement scale         | 22. Replacement pump   |

23. Lower pinch valve

24. Blood warmer connection

## CVVHD therapy

CVVHD therapy provides hemodialysis and allows for PBP infusion ("CVVHD therapy setup", page 209).

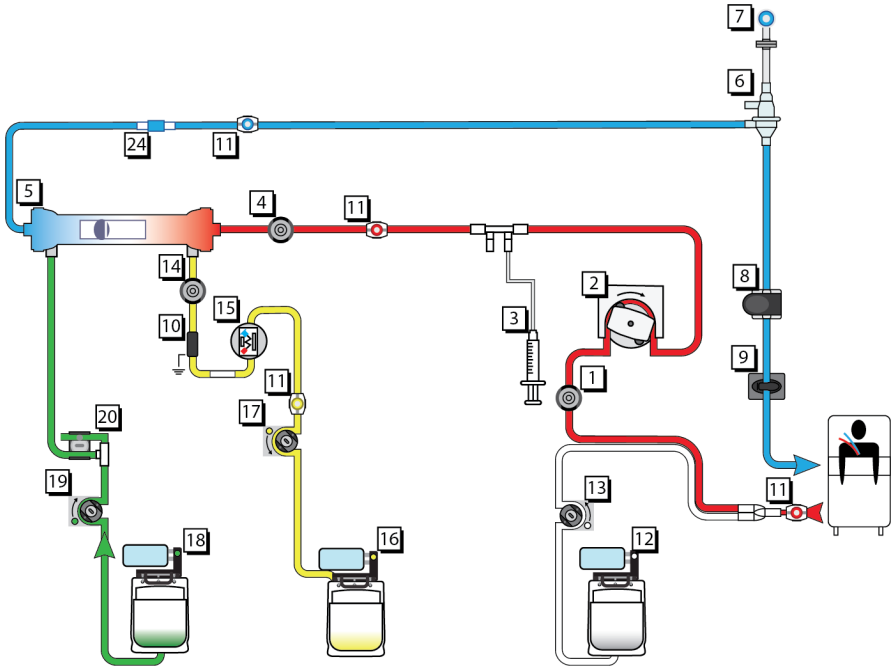

Figure CVVHD therapy setup

- |                               |  |
|-------------------------------|--|
| 1. Access pressure sensor     | 2. Blood pump  |
| 3. Syringe pump               | 4. Filter pressure sensor                                    |
| 5. Filter                     | 6. Deaeration chamber  |
| 7. Return pressure sensor     | 8. Air Bubble Detector (ABD),<br>patient sensor, line sensor |
| 9. Return clamp               | 10. Discharger ring guide                                    |
| 11. Sample site               | 12. PBP scale  |
| 13. PBP pump                  | 14. Effluent pressure sensor                                 |
| 15. Blood Leak Detector (BLD) | 16. Effluent scale   |
| 17. Effluent pump             | 18. Dialysate scale  |
| 19. Dialysate pump            | 20. Upper pinch valve  |
| 21. Blood warmer connection   |  |

## CVVHDF therapy

CVVHDF therapy provides hemodiafiltration with pre- or post-filter replacement infusion and allows for PBP infusion ("CVVHDF therapy setup", page 210).

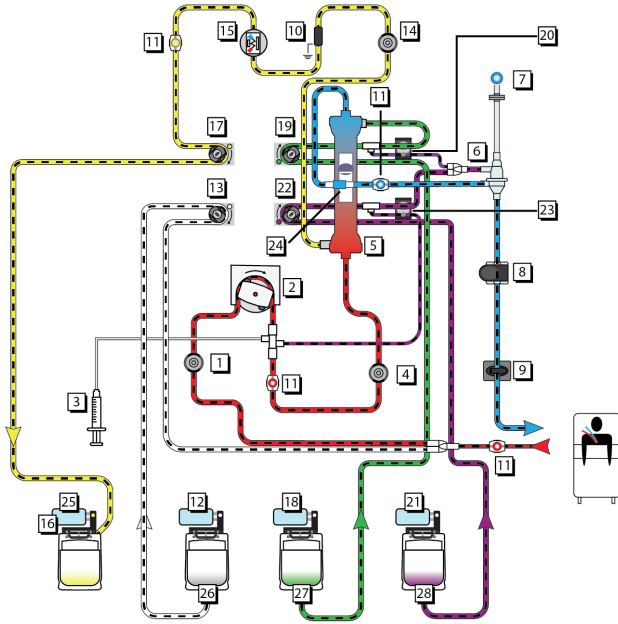

Figure CVVHDF therapy setup

- |                               |  |
|-------------------------------|--|
| 1. Access pressure sensor     | 2. Blood pump  |
| 3. Syringe pump               | 4. Filter pressure sensor                                    |
| 5. Filter                     | 6. Deaeration chamber  |
| 7. Return pressure sensor     | 8. Air Bubble Detector (ABD),<br>patient sensor, line sensor |
| 9. Return clamp               | 10. Discharger ring guide                                    |
| 11. Sample site               | 12. PBP scale  |
| 13. PBP pump                  | 14. Effluent pressure sensor                                 |
| 15. Blood Leak Detector (BLD) | 16. Effluent scale   |
| 17. Effluent pump             | 18. Dialysate scale  |
| 19. Dialysate pump            | 20. Upper pinch valve  |
| 21. Replacement scale         | 22. Replacement pump   |

- |                                     |                                       |
|-------------------------------------|---------------------------------------|
| 23. Lower pinch valve               | 24. Blood warmer connection           |
| 25. Effluent fluid line connection  | 26. PBP fluid line connection         |
| 27. Dialysate fluid line connection | 28. Replacement fluid line connection |
|                                     | connection                            |

The following diagram shows the relationship of the Effluent line to the Auto Effluent (AE) accessory and its constituent parts:

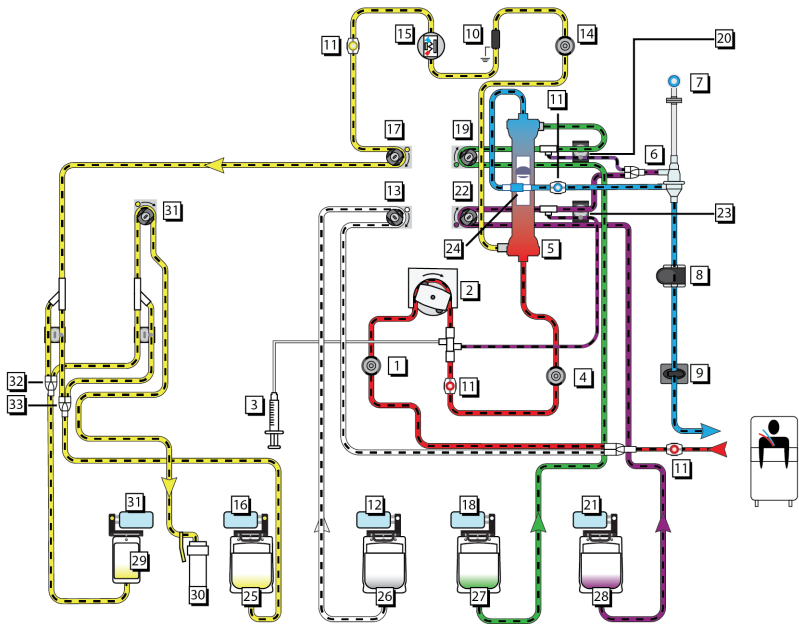

Figure CWVHDF AE therapy setup

- |                               |                              |
|-------------------------------|------------------------------|
| 1. Access pressure sensor     | 2. Blood pump                |
| 3. Syringe pump               | 4. Filter pressure sensor    |
| 5. Filter                     | 6. Deaeration chamber        |
| 7. Return pressure sensor     | 8. ABD (Air Bubble Detector) |
| 9. Return clamp               | 10. Discharger ring          |
| 11. Sample site               | 12. PBP scale                |
| 13. PBP pump                  | 14. Effluent pressure sensor |
| 15. BLD (Blood Leak Detector) | 16. Effluent scale           |
| 17. Effluent pump             | 18. Dialysate scale          |
| 19. Dialysate pump            | 20. Upper pinch valve        |
| 21. Replacement scale         | 22. Replacement pump         |

- |                                     |                                       |
|-------------------------------------|---------------------------------------|
| 23. Lower pinch valve               | 24. Blood warmer connection           |
| 25. Front AE 5L bag                 | 26. PBP fluid line connection         |
| 27. Dialysate fluid line connection | 28. Replacement fluid line connection |
| 29. Rear AE 1L bag                  | 30. Effluent drain hookup             |
| 31. AE drain pump                   | 32. AE fill pinch valve               |
| 33. AE drain pinch valve            |                                       |

## Replacement solution

The replacement solution delivery options vary according to the selected therapy and anticoagulation.

Table **Replacement solutions and delivery options**

| Therapy          | Delivery             | Scale and pump for replacement solution                  |
|------------------|----------------------|--|
| CVWH             | 100% pre-filter      | Replacement (purple)                                     |
|                  | Pre- and post-filter | Replacement (purple) delivers pre-filter portion         |
|                  |                      | Replacement 2 (green) delivers post-filter portion       |
|                  | 100% post-filter     | Replacement (purple) delivers 50% of selected flow rate  |
|                  |                      | Replacement 2 (green) delivers 50% of selected flow rate |
|                  | CWHDF                | 100% pre-filter  |
| 100% post-filter |                      | Replacement (purple)                                     |

# CRRT disposable sets

## About CRRT disposable sets

**CAUTION!**

Blood priming the extracorporeal circuit with citrated blood can result in patient reactions. Verify pH and level of ionized calcium in primed circuit prior to patient connection.

There are two types of CRRT sets. High flow and low flow sets that are different based on the size of the blood pump tubing. For more information about set characteristics and operating ranges, see the instructions for use that come enclosed with the disposable set.

Low-flow CRRT sets include: M60.

High-flow CRRT sets include: M100, M150, HF1000, HF1400, oXiris.

Set performance can decline during longer treatments. To prevent this, an advisory message to change the set is shown based on the treatment time.

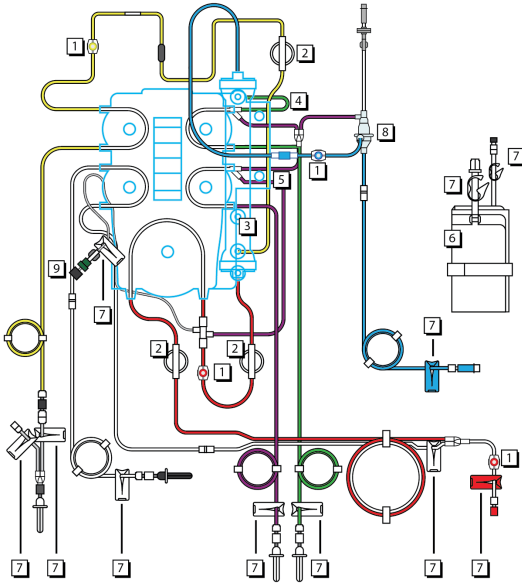

Figure CRRT disposable set components

- |  |   |
|--|---|
| 1. Sample sites                                  | 2. Pressure pods                                |
| 3. Filter  | 4. Upper pinch valve segment<br>(green-striped) |
| 5. Lower pinch valve segment<br>(purple-striped) | 6. Effluent bag                                 |
| 7. Clamps  | 8. Deaeration chamber                           |
| 9. Check-valve                                   |   |

The CRRT set consists of the following components:

1. Sample sites are located on the following lines:

- access line before the junction with PBP infusion line (red)
  - access line after the blood pump (red)
  - return line between filter outlet and deaeration chamber (blue)
  - effluent line (yellow)
2. Pressure pods are located on the following lines:
- access line before blood pump (access pod)
  - access line after blood pump (filter pod)
  - effluent line before effluent pump (effluent pod)
3. The filter contains hollow fibers made of a semi-permeable membrane. Blood flows through the hollow fibers, while filtrate and/or dialysate flow counter-currently in the fluid compartment.
4. The upper pinch valve segment (green-striped) automatically threads through the upper and lower pinch valves when the set is loaded. Pinch valves can close or open the tubing.
- CVVHD, CVVHDF: Delivers solution from the dialysate (green) scale to the fluid side of the filter.
  - CVVH: Delivers solution from the replacement 2 (green) scale post-filter to the deaeration chamber on the return line.
5. The lower pinch valve segment (purple-striped) automatically threads through the upper and lower pinch valves when the set is loaded. Pinch valves can close or open the tubing.
- CVVH, CVVHDF: Delivers solution from the replacement (purple) scale to, either Pre-filter (to the access line just before the filter) or Post-filter (to the deaeration chamber on the return line).
6. Effluent bag (5 L or 9 L) collects effluent.

## Patient fluid balance

### **Patient fluid removal prescription makeup**

The system can adapt for paused in therapy by performing PFR Catch-up. The PFR Catch-up slightly increase the fluid removal until the PFR matches the prescription. To adjust the PFR Catch-up setting during Setup, select Other Settings when selecting the prescription.

The makeup feature can accommodate for up to 10 minutes of PFR downtime. For example, due to a bag change or alarm, software automatically makes up for the down time to maintain an average patient fluid removal rate equal to the selected PFR rate. To do this, the effluent pump speed is at a high rate.

### **Protecting from fluid imbalance**

The **PrisMax** system monitors the patient fluid removed to protect the patient from fluid imbalance. In CRRT, additional information is reported on the History screen to help the operator understand the larger picture related to the patient's fluid balance. This information includes the Unintended Patient Fluid Gain, expressed as the accumulated fluid balance error within the last three hours.

If the patient fluid removed is higher than the target value, there is an alarm for unintended fluid loss. If the patient fluid removed is lower than the target value, there is an alarm for unintended fluid gain. The displayed unintended fluid gain or loss is cumulative. To view current gain/loss, tap the **Therapy** button to view the Prescription screen.

A default safety limit makes sure that excessive fluid cannot be unintentionally removed from or infused to the patient across the semi-permeable membrane of the filter during abnormal conditions. The physician-prescribed gain/loss limit is based on the patient's ability to tolerate potential fluid imbalance.

The acceptable limit for the fluid balance error (Gain/Loss Limit) is patient specific. It follows from the maximum UF rate error, which is not to exceed 0.1 mL/kg/min in order to avoid complications including haemodynamic instability. Accordingly, the Gain/Loss Limit default is set based on the cumulative UF rate error over a sliding 3 hour window. The Patient Fluid Removal accuracy of the system ( $\pm 70$  mL/3h) is to be considered in this interval.

The default Gain/Loss Limit is to be confirmed by the operator during the setup-phase of the treatment based on the physician's prescription.

To prevent serious, unintended patient fluid loss or gain, the Caution: Loss/Gain Limit Reached alarm permanently suspends treatment (fluid pumps will not re-start). This alarm requires the operator to end the treatment. The alarm screen reports the amount of unintended patient fluid loss or gain that has accumulated and shows the operator that this amount now matches the allowed limit. For patient charting, the operator should make a written note of the mL of Unintended Patient Fluid Loss or Gain reported.

A pop-up window asks for confirmation to stop the treatment and whether to return the blood in the set to the patient. Starting a new

treatment on a previous patient resets the cumulative gain or loss to 0 ml.

The **PrisMax** system continuously performs gain/loss calculations on two independent processors by examining weight changes between the fluid being infused and extracted from the patient's blood. If the source of the inaccuracy is not resolved, the gain/loss limit continues to accumulate. Typically, a fault condition is due to a clamped line, a bag being incorrectly suspended with tension on the tubing, or the bag being partially supported. Once the maximum limit is reached, the set must be replaced.

To eliminate the potential for fluid balance errors, it is important to make sure that the fluid lines hang freely from the set to the bags and that the blood lines do not contact the bags.

## CRRT software calculations

This section summarizes software calculations used in CRRT therapies. See "Abbreviations", page 196, for abbreviations.

### **Effluent pump rate**

Software calculates the needed effluent flow rate to get the selected PFR rate. This formula describes the effluent pump rate for CRRT:

$$Q_{\text{eff}} = Q_{\text{pfr}} + Q_{\text{pbp}} + Q_{\text{rep}} + Q_{\text{dial}} + Q_{\text{syr}} + Q_{\text{makeup}}$$

The effluent pump increases or decreases to keep the effluent flow rate set. Effluent pump does not compensate for other fluid flow rates error. Effluent pump can also increase for make-up. View the current gain/loss volume and makeup volume in the Prescription window. See "Changing flow rates, solutions bags and syringes", page 70 for PFR Catch-up information.

### **Transmembrane pressure and filter drop**

During CRRT therapies, software uses monitored pressure values to calculate TMP and filter pressure drop,  $\Delta P_{\text{fil}}$ . Software monitors these pressures to sense clotting or clogging.

The Operations screen shows the current TMP and  $\Delta P_{\text{fil}}$  during a patient treatment. It is possible to see a graph showing the trends of these two pressures over a period of one to three hours in the History screen.

TMP is the applied pressure across the filter membrane during operation, and shows the pressure difference between the blood and fluid compartments of the filter. TMP is calculated as follows:

- **TMP** =  $[(P_{\text{fil}} + P_{\text{ret}}) / 2] - P_{\text{eff}} - 18 \text{ mmHg}$

The software automatically corrects the the filter pressure and effluent pressure by -18 mmHg to correct for hydrostatic pressure biases.

During patient treatment, membrane permeability decreases due to protein coating on the blood side of the membrane. This increases the TMP. During operation, software sets the initial TMP value when the initial pressure operating points are established shortly after treatment starts. Software resets the initial TMP value following every self test and change to blood flow rate, PFR rate, or replacement solution rate.

The amount of increase above the initial TMP value adds to the filter clotting alarm. This TMP parameter can only be set by an authorized service technician. An alarm occurs if TMP is higher than +300 mmHg.

### **Total predilution**

Software calculates the total predilution value, which is the ratio of pre-filter blood dilution to the total blood dilution. The total predilution is calculated the following way: describes total predilution:

$$\mathbf{PRE\%_{tot}} = (Q_{pbp} + Q_{rep\_pre}) / (Q_{pbp} + Q_{rep})$$

The Operations screen displays the total predilution value.

### **Filtration fraction**

Software calculates the filtration fraction, FF%, value. FF% reflects the level of blood hemoconcentration at the filter outlet in one of two ways. Both are shown on the Information screen.

$$\mathbf{FF\ Blood\ \%} = 100 \times (Q_{rep\_post} + Q_{pfr} + Q_{syr}) / (Q_{plasma} + Q_{pre})$$

$$\mathbf{FF\ Plasma\ \%} = 100 \times Q_{eff} / (Q_{plasma} \times 0.95 + Q_{pre})$$

$$\mathbf{PreREP\ \%} = Q_{rep\_pre} / (Q_{rep})$$

- $Q_{plasma\_in} = Q_{rep\_pre} + Q_{pbp} + Q_{plasma}$

- $Q_{plasma} = (1 - (Hct / 100)) \times Q_b$

The Review Prescription screen shows the FF Blood % and FF Plasma %.

### **Post-filter hematocrit**

Software calculates the post-filter hematocrit ( $Hct_{post}$ ) value as:

$$\mathbf{Hct}_{post} = (Q_b \times Hct) / (Q_b - Q_{ufpost})$$

Ultrafiltration flow rate is calculated as:

$$\mathbf{Q}_{ufpost} = Q_{rep\_post} - Q_{pfr}$$

**Plasma water flow rate**

Plasma flow rate is computed as a function of blood flow rate and patient's hematocrit:

$$Q_{\text{plasma}} = [1 - (\text{Hct} / 100)] \times Q_b \times F_p$$

$F_p = 0.95$ , Plasma water fraction is the water fraction in whole plasma.

**Patient fluid removal rate****WARNING!**

The overall patient fluid balance is subject to fluid losses or gains outside the control of the **PrisMax** system.

Periodically weigh the patient to verify the overall fluid balance.

The Patient fluid removal (PFR) rate is the net amount of fluid removed from the patient each hour after accounting for any PBP or replacement solutions and syringe infusion volumes. Net fluid removal occurs whenever PFR rate is set above zero.

Software cannot measure or account for external sources of patient fluid intake or output. Examples of fluid intakes are hyperalimentation, blood, or drug infusion. Examples of fluid outputs are urine and wound drainage. It is important to take these other sources into account when calculating the PFR rate and the input and output totals. Adjust the PFR rate if the weight loss prescription changes or if the external fluid inputs or outputs change.

**Patient fluid removed**

Patient fluid removed is the net amount of fluid removed from the patient by the system during a specified time period. It is used in periodic totaling of patient I/O volumes. The patient fluid removed should be the same as the selected PFR rate.

The four scales on the control unit support the PBP, replacement solution, dialysate, and effluent bags and measure their weights constantly. The change in combined weight of the fluid bags in use indicates how much fluid has been removed from the patient. Software automatically accounts for replacing fluid bags. This formula describes patient fluid removed:

$$V_{\text{pfr}} = V_{\text{eff}} - V_{\text{pbp}} - V_{\text{dial}} - V_{\text{rep}} - V_{\text{syr}}$$

**CRRT dose**

Software computes two indicators of the CRRT treatment dose, in ml/kg/h, as a function of flow rate settings and patient body weight. The displayed dose calculation is set in System Configuration. See the System Configuration section of this manual.

Effluent dose is the effluent flow rate normalized to patient body weight.

UFR dose includes the fluid amounts contributed by PBP, replacement, and PFR rates, corrected for pre-dilution and normalized to patient body weight.

These equations describe CRRT dose:

$$D_{\text{CRRT-eff}} = Q_{\text{eff}} / \text{BW}$$

$$D_{\text{CRRT-UFR}} = [Q_{\text{plasma\_in}} / (Q_{\text{plasma\_in}} + Q_{\text{pre}})] \times (Q_{\text{uf}} / \text{BW})$$

Pre-infusion flow rate is calculated as follows:

$$Q_{\text{pre}} = Q_{\text{pbp}} + Q_{\text{rep}} (\text{PRE}\% / 100) \times Q_{\text{syr}}$$

## Therapeutic Plasma Exchange (TPE)

### About Therapeutic Plasma Exchange (TPE)



#### **WARNING!**

In TPE, the blood flow rate should not be set below 100 mL/min for TPE2000 sets due to risk of hemolysis.



#### **WARNING!**

It is recommended to obtain a detailed drug history before each TPE procedure. For drugs potentially affected by TPE, the physician should either adjust the doses or give the medications immediately after the procedure, since drugs will pass through the membrane of the filter.



#### **WARNING!**

As treatment proceeds, carefully monitor patient plasma balance levels in the History screens.



#### **WARNING!**

Monitor patient temperature to avoid hypo- or hyperthermia. Pay special attention when using high fluid exchange rates, when using a high capacity blood warmer, or when treating low body weight patients.

**WARNING!**

The blood leak detector must be re-normalized if the effluent line has been removed and then reinserted into the blood leak detector during an ongoing treatment. See "Blood Leak Detector (BLD) normalization", page 36.

**WARNING!**

TPE in conjunction with citrate containing replacement solutions may require calcium substitution in order to avoid hypocalcaemia.

**CAUTION!**

PBP solution delivery is not removed in TPE. Therefore this fluid volume is considered as a fluid input in the patient fluid balance.

**CAUTION!**

TPE requires use of replacement fluid with adequate protein content in order to avoid hypoproteinemia.

**CAUTION!**

Observe the effluent bag for pink or red tinge as an indicator of undetected micro blood leaks or hemolysis.

**CAUTION!**

When changing bags/containers during TPE, it is important to enter the new replacement container volume on the Change Bags screen. If the volume for the replacement container is wrong, air could be introduced into the set.

**CAUTION!**

Use saline or alkaline solution (pH  $\geq$  7.3) to prime the set, with or without heparin added according to hospital/clinic practice.

**Mechanism of TPE**

In Therapeutic Plasma Exchange (TPE), blood plasma and therein contained disease mediators are removed from the patient's blood through filtration over a filter membrane. A replacement fluid is administered in order to compensate for the plasma volume that is removed through this plasmafiltration process.

# TPE flowchart

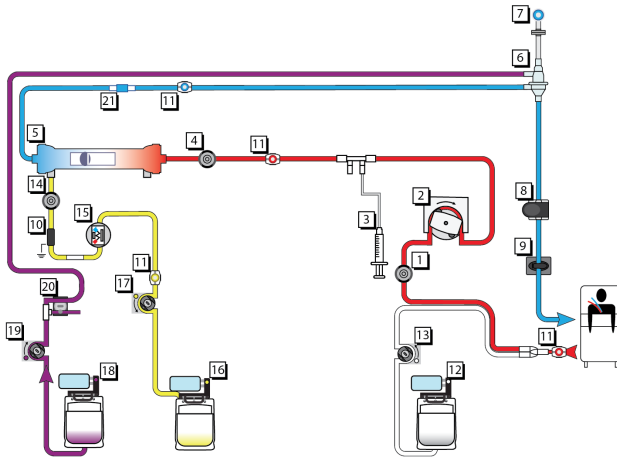

Figure TPE flow

- |                                 |  |
|---------------------------------|--|
| 1. Access pressure sensor       | 2. Blood pump                          |
| 3. Syringe pump                 | 4. Filter pressure sensor              |
| 5. Filter                       | 6. Deaeration chamber                  |
| 7. Return pressure sensor       | 8. Air bubble detector and line sensor |
| 9. Return clamp and line sensor | 10. Discharger ring guide              |
| 11. Sample site                 | 12. Scale, PBP bag                     |
| 13. PBP pump                    | 14. Effluent pressure sensor           |
| 15. Blood leak detector         | 16. Scale, effluent bag                |
| 17. Effluent pump               | 18. Scale, replacement bag             |
| 19. Replacement pump            | 20. Upper pinch valve                  |
| 21. Blood warmer connection     |  |

## TPE and anticoagulation methods

Anticoagulation methods available in TPE therapy are Systemic or No anticoagulation.

## TPE disposable sets

### High-flow sets

The available disposable sets for high flow sets are:

- TPE2000

Refer to the Instructions for Use enclosed with the set.

## Specific functions in TPE

### Bag management

TPE replacement solutions are being administered from containers having various weights and sizes. Accordingly, the replacement and PBP scales in TPE are per default managed with the Variable Empty Bag method. To facilitate the use of small size TPE replacement containers, volumes can be adjusted down to a minimum of 10 mL, in steps of 1 mL.



#### NOTE!

In TPE, bags are only used on PBP and replacement scales. The dialysate scale will not be used.

### Patient plasma loss

The **PrisMax** software automatically calculates the effluent flow rate needed to achieve the patient plasma loss rate. Any replacement solution infused by the **PrisMax** control unit is automatically accounted for, as shown below:

- $Q_{\text{eff}} = Q_{\text{ppl}} + Q_{\text{rep}}$

Where  $Q_{\text{eff}}$  is effluent rate (mL/h),  $Q_{\text{ppl}}$  is patient plasma loss rate (mL/h) and  $Q_{\text{rep}}$  is replacement fluid rate (mL/h).

During operation, software controls the effluent pump speed to maintain the required effluent rate. PBP solution and syringe infused

volumes are not accounted for when defining the TPE effluent flow rate; these infused volumes are net fluid inputs for the patient.

## Protecting from fluid imbalance

### Protecting the patient from plasma imbalance

The **PrisMax** system is designed to provide exchange of plasma from the patient's blood, net plasma loss from the patient's blood, or both. If net plasma loss is not desired, the **PrisMax** system is designed to operate to maintain a zero plasma balance in the patient's blood (no net plasma loss or gain). Flow problems in the fluid lines, bags, or pump segments can change the flow rate within the fluid lines and the filter and cause errors in the amount of patient plasma loss. The **PrisMax** safety system protects from these situations via alarms that suspend the treatment and alert the operator. In addition to the alarm system described in "Alarm safety and monitoring systems", page 93, the **PrisMax** system monitors for accumulated error from the Effluent and Replacement scales. All these alarms are described in detail below.

### Scale error problem alarms in TPE

During treatment, the effluent, PBP, and replacement scales may experience conditions that cause the readings to fluctuate, thus causing uncertainty in the actual mass on the scale. These uncertainties can accumulate and can result in unintended patient plasma loss or gain. The scale error alarm permanently suspends treatment (fluid pumps will not re-start). This alarm requires the operator to end the treatment. The **Discard Set** button is provided on the alarm screen and accesses the Stop screen. When ready to end the treatment, the operator should tap this key and follow the online instructions. The return blood option will be available.



#### **NOTE!**

The **STOP** softkey should be tapped only when ready to proceed with the end treatment sequence.

### Protecting from excessive fluid input

As the effluent pump does not account for PBP solution, any PBP solution constitutes an additional fluid input to the patient. To prevent unintended fluid input, the PBP Fluid Limit Reached alarm occurs once the volume of infused PBP solution reaches the predefined threshold and suspends the treatment. The operator can then decide to either stop or to continue the treatment. See the chapter "Troubleshooting" for detailed troubleshooting information.

## Pressure management

### Software-calculated pressures

During TPE therapy, **PrisMax** software uses monitored pressure values to calculate Access Transmembrane pressure (TMPa) in addition to the filter pressure drop (Pressure Drop). TMPa is used to provide notification when the membrane pore are plugging or plugged. Filter pressure drop is used to provide notification that the filter set is clotting or clotted. Pressure alarms for both of these conditions are provided to help the user determine when to change the set. The TMPa and Pressure Drop are displayed and updated on the Operations screen during a patient treatment. In addition, the trends of these two pressures over an operator-controllable period of one to three hours can be displayed on the History screen.

### Access transmembrane pressure (TMPa)

Access transmembrane pressure is the pressure difference between the blood and fluid compartments at the inlet side of the filter.

The TMPa is calculated by the **PrisMax** software as follows:

- $TMPa = P_{fil} - P_{eff}$

Where TMPa is access transmembrane pressure (mmHg),  $P_{fil}$  is filter pressure (mmHg) and  $P_{eff}$  is effluent pressure (mmHg).

Filter pressure and effluent pressure readings are automatically corrected by software for hydrostatic pressure biases to compute and display TMPa data (-30 mmHg correction).

During a patient treatment, permeability of the membrane decreases due to protein coating on the blood side of the membrane. This causes the TMPa to increase. In order to help prevent hemolysis, the pressure gradient between blood inlet and the effluent outlet of the filter should be strictly controlled and the blood flow rate should not fall below minimum recommended flow rate of the selected **PrisMax** system TPE disposable set.

There are two alarms specific to TMPa: TMPa Excessive alarm and the TMPa Too High alarm.

## Start-up phase

To promote blood safety, the start-up of replacement and effluent pumps is delayed in order to allow the blood to completely fill all the parts of the set. This delay will be 3 minutes plus how long it takes to fill the set with blood based on the blood flow rate. This allows blood

to initially contact the filter without the influence of ultrafiltration pressures. This TPE start-up phase also allows the operator to change bags/containers as wished, before the actual treatment commences.

### TPE prescription delivered

Unlike CRRT, a TPE therapy is not a continuous treatment. For the **PrisMax** system the duration of a TPE treatment is defined in respect to a target replacement volume that is to be exchanged (Total Exchange Volume) and the rate of replacement flow. Once this prescribed volume has been delivered the **PrisMax** control unit notifies the operator through a TPE Prescription Delivered pop-up window. The operator can then choose either to stop the treatment, to continue the treatment until the replacement bag is empty, or to set a new replacement volume target.

### End treatment

Per design, TPE treatments will commonly be ended on occurrence of TPE Prescription Delivered pop-up window. If needed, treatment can be ended any time by pressing the **STOP** softkey present on the Operations screen.

## Therapy operation in TPE

### TPE prescription and flow rates

#### About TPE prescription and flow rates

The TPE Prescription consists of three settings: Patient Hematocrit; Total Exchange Volume (total amount of replacement fluid to infuse over the entire treatment); and Replacement Container Volume (volume of replacement fluid in the bag/ container hanging on the scale).

Flow rates are the settings that control the rate of blood flow, patient plasma loss, PBP and replacement fluid infusion, and effluent flow during a patient treatment. All flow rates except effluent are user-controllable.

#### Adjusting the TPE prescription and flow rates

During the Setup procedure (Setup mode), after the patient info has been entered, the Prescription screen is displayed. The operator is prompted to enter the settings and flow rates and confirm all values prior to attaching the TPE filter set. During treatment, tap the appropriate flow rate box on the Operations screen to reach the Prescription Change screen to change flows.

**NOTE!**

There is no default value for the Replacement Container Volume. The volume of fluid in the replacement container must be entered for each bag change.

**Considerations when using PBP solution**

When using PBP solution during TPE, be aware of the considerations below:

- The effluent pump rate does not account for PBP solution. Any PBP solution infused must be counted as a separate fluid input when calculating patient Input/Output totals.
- The software-calculated Target Patient Plasma Loss does not account for PBP solution. See "Patient plasma loss rate", page 227.

**Patient plasma loss rate**

The patient plasma loss rate is the net amount of plasma the **PrisMax** system removes from the patient each hour after accounting for any replacement fluid being used.

If the patient plasma loss rate is set above zero, a net plasma loss occurs, resulting in a negative plasma balance in the patient.

In TPE, the physician usually prescribes a zero net plasma loss; therefore, in most cases the patient plasma loss rate is set to 0 mL/h.

**Software calculations of target patient plasma loss**

The **PrisMax** software calculates a Target Patient Plasma Loss based on settings entered by the operator. This calculated value is displayed on the Prescription Change screen.

Software calculates the Target Patient Plasma Loss by first determining the treatment time according to the formula below.

$$T = V_{\text{exch}(\text{tot})} / Q_{\text{rep}}$$

Where T is Treatment time (h),  $V_{\text{exch}(\text{tot})}$  is Volume to replace (Total Exchange Volume (mL)) and  $Q_{\text{rep}}$  is Replacement fluid rate (mL/h).

Target Patient Plasma Loss is then calculated as follows:

$$V_{\text{ppl}(\text{tgt})} = Q_{\text{ppl}} \times T$$

Where  $V_{\text{ppl}(\text{tgt})}$  is Target patient plasma loss (mL),  $Q_{\text{ppl}}$  is Patient plasma loss rate (mL/h) and T is Treatment time (h).

If the total exchange volume, replacement fluid rate, or patient plasma loss rate is changed during a treatment, the Target Patient Plasma Loss also changes.



**NOTE!**

The Target Patient Plasma Loss for the treatment must be the same number as the net plasma loss prescribed by the physician, whether this is zero or a number above zero.

**Setting the patient plasma loss rate to achieve prescribed target loss**

If the prescribed net plasma loss is above zero, the operator must indirectly enter this volume as the Target Patient Plasma Loss value. This is done during the Setup procedure on the prescription screen by using the PPL flow rate control.



**NOTE!**

The software-calculated Target Patient Plasma Loss does not account for PBP solution.

**Formulas used in TPE**

Below is a summary of the formulas used by the **PrisMax** software in managing TPE. Software calculations are based on the operator-set TPE Prescription and flow rate values. The results of software calculations are displayed on the Prescription screen.

- $V_{\text{plasma}} = (100 - \text{Hct}) \times 0.7 \times \text{BW}$

where  $V_{\text{plasma}}$  is Patient plasma volume (mL), Hct is Hematocrit (%), BW is Patient body weight (kg).

- $R_{\text{exch}} = V_{\text{exch}(\text{tot})} / V_{\text{plasma}}$

where  $R_{\text{exch}}$  is Plasma volume exchange (dimensionless),  $V_{\text{exch}(\text{tot})}$  is Total Exchange Volume (mL) and  $V_{\text{plasma}}$  is Patient plasma volume (mL).

- $\text{Hct}_{\text{post}} = [(Q_b / (Q_b - Q_{\text{eff}})] \times \text{Hct}$

where  $\text{Hct}_{\text{post}}$  is Post-filter Hematocrit (%),  $Q_b$  is Operator set blood flow rate (mL/h), Hct is Hematocrit (%) and  $Q_{\text{eff}}$  is Effluent flow rate (mL/h).

- $\text{FF} = 100 \times (Q_{\text{rep}} + Q_{\text{ppl}}) / (Q_b + Q_{\text{pbp}})$

where FF is Filtration fraction (%),  $Q_{\text{ppl}}$  is Patient plasma loss rate (mL/h),  $Q_{\text{rep}}$  is Replacement flow rate (mL/h) and  $Q_{\text{inlet}}$  is filter inlet flow rate at filter inlet (mL/h).

- $V_{\text{eff}(\text{tgt})} = Q_{\text{eff}} \times T$

where  $V_{\text{eff(tgt)}}$  is Target effluent (mL),  $Q_{\text{eff}}$  is Effluent rate (mL/h) and T is Treatment time (h).

- $V_{\text{ppl(tgt)}} = Q_{\text{ppl}} \times T$

where  $V_{\text{ppl(tgt)}}$  is Target patient plasma loss (mL),  $Q_{\text{ppl}}$  is Patient plasma loss rate (mL/h) and T is Treatment time (h).

## Plasma balance

### Patient plasma loss

Patient Plasma Loss is the net amount of plasma removed from the patient by the **PrisMax** system during a specified time period. In TPE, the physician usually prescribes a zero net plasma loss for the patient.

### Measuring patient plasma loss

The replacement scale and effluent scale mounted on the bottom of the **PrisMax** control unit support the replacement fluid bag/container and effluent bag and constantly measure their weights. The change in combined weight of the fluid bags/containers in use indicates how much plasma has been removed from the patient by the control unit.

When fluid bags/containers are replaced, the software automatically accounts for their new weights. The following formula applies:

- $V_{\text{ppl}} = V_{\text{eff}} - V_{\text{rep}}$

Where  $V_{\text{ppl}}$  is Patient plasma loss (mL),  $V_{\text{eff}}$  is Effluent bag volume (mL) and  $V_{\text{rep}}$  is Replacement solution volume (mL).

During Setup, **PrisMax** will calculate the total plasma loss volume by multiplying the Patient Plasma Loss (PPL) rate by the length of treatment time. It will show this volume on the Prescription screen, dynamically updating it per flow rate changes.

**PrisMax** will calculate the treatment time duration by dividing the total plasma loss volume by the Patient Plasma Loss (PPL) rate. This treatment duration will be shown on the Prescription screen, dynamically updating it per flow rate changes

### Viewing Patient Plasma Loss

During a patient treatment, the Patient Plasma Loss (PPL) volume is displayed on the History screen. It will continually increase (if PPL > 0) while the replacement pump is running until it gets to the estimated plasma loss volume shown on the Prescription screen.

## Viewing treatment data

### **Information included in treatment data**

In History screen, treatment data includes following information for TPE treatments:

- Patient Plasma Loss (net plasma volume removed)
- Patient fluid gain
- Total exchange volume
- Plasma volume exchanged
- TPE duration
- Doses (cumulated volume and average dose)
  - Ultrafiltration
  - Replacement Solution Input (incl. PBP)
  - Pre-filter Input (PBP input, not included in effluent)
  - Post-filter Input (actual volume delivered, replacement fluid pumped)
  - Effluent (total plasma volume removed)
  - Cumulative volumes for the scales
  - TPE total volumes
  - Replacement exchange volume
  - Plasma volume exchange
  - Patient fluid gain
- Cumulated volume for:
  - Pre Blood Pump
  - Replacement (actual replacement volume delivered)
  - Syringe
  - Effluent

## Replacement bag handling

### Bag or container volume

Replacement fluid for TPE may be stored in small volumes bags or containers that require multiple changes during the treatment.

### Using multiple bags or containers in parallel



#### **WARNING!**

When hanging a fluid bag, evenly distribute its weight amongst the three hooks of the scale carrying bar. If only one hook is needed, use the center hook. Failure to comply can significantly alter fluid balance.

Using the accessory SP394 with the **PrisMax** system in TPE requires a special procedure. The device can be used to connect several containers (bags or bottles) of replacement fluid. See

"Accessory SP394 with the PrisMax system in TPE", page 232.

1. The end of the line equipped with the vented spike (accessory with blue cap) must be connected to the first container. The other end of this line is then connected to the second container.
2. The second line (with the non-vented spike) is used to connect the second container to the third one.
3. The third container is then connected to the replacement line of the **PrisMax** system's TPE disposable set.

When bottles are used, the vented cap (blue) of the spike attached to the first bottle must be open.

When bags are used, the vented cap (blue) of the spike can remain closed.



#### **NOTE!**

After one of the lines is connected to a container, it is recommended to prime the line by gravity and clamp it before attaching the other end of the line to another container.

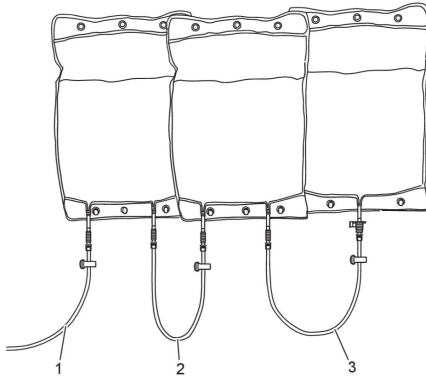

Figure Accessory SP394 with the PrisMax system in TPE

1. Replacement fluid line of TPE set
2. Second line equipped with the non-vented spike
3. First line equipped with the vented spike (blue cap)

### **Handling empty bag/container alarm**

The Replacement Bag/Container Empty alarm appears when the machine has consumed the set volume for the replacement container.

The operator then has two options:

1. Change the container;
2. Decide to use a residual volume in the container already hanging on the scale. In this case an opening/closing sequence, including lifting the bag (without changing container) must be performed on the scale, and the residual volume to consume must be set.

## Chapter 6

# Device description

|                                  |            |
|----------------------------------|------------|
| <b>Control unit functions</b>    | <b>235</b> |
| <b>Flow path management</b>      | <b>236</b> |
| About flow path management ...   | 236        |
| Blood access ...                 | 237        |
| Pressure monitoring ...          | 238        |
| <b>Fluid management</b>          | <b>241</b> |
| About fluid management ...       | 241        |
| Pumps and scales ...             | 242        |
| Solution bags ...                | 243        |
| Empty bag detection ...          | 243        |
| Auto Effluent (AE) accessory ... | 244        |
| Fluid balance ...                | 244        |
| <b>Air management</b>            | <b>245</b> |
| About air management ...         | 245        |
| Foam management ...              | 245        |
| <b>Anticoagulation</b>           | <b>246</b> |
| About anticoagulation ...        | 246        |
| <b>Components</b>                | <b>247</b> |

|  |            |
|--|------------|
| <b>Control unit</b>                                      | <b>250</b> |
| <b>Power control panel</b>                               | <b>251</b> |
| <b>Pumps</b>   | <b>252</b> |
| <b>Left side panel and drip tray</b>                     | <b>254</b> |
| <b>Pressure sensors and deaeration chamber holder</b>    | <b>256</b> |
| About pressure sensors and deaeration chamber holder ... |            |
| 256  |            |
| Access, filter, and effluent monitoring ...              | 257        |
| Return monitoring ...                                    | 258        |
| <b>Pinch valves, return clamp and detectors</b>          | <b>259</b> |
| <b>Front scales</b>                                      | <b>261</b> |
| <b>Miscellaneous components</b>                          | <b>262</b> |
| <b>Back panel</b>  | <b>263</b> |
| <b>Remote screen viewing</b>                             | <b>264</b> |
| <b>On device training</b>                                | <b>265</b> |

# Device description

## Control unit functions

The **PrisMax** control unit is a software-controlled device that performs the following functions:

- Loads and primes the Prismaflex disposable set automatically
- Pumps blood through the blood flow path of the Prismaflex disposable set
- Delivers anticoagulant solution into the blood flow path
- Pumps sterile infusion solutions into the blood flow path of the Prismaflex disposable set, according to the therapy in use
- Pumps sterile dialysate into the fluid compartment of the filter in CRRT therapies
- Controls the patient fluid removal or plasma loss, according to the therapy in use
- Monitors the system and alerts the operator to abnormal situations through alarms

# Flow path management

## About flow path management

The **PrisMax** blood path includes:

- Access line: the access line connects the patient catheter to the inlet of the blood pump segment. It includes an access pressure pod. The PBP pump output line is connected to the access line just after the blood flow enters the access line.
- Blood pump segment: the blood pump segment is inserted in a peristaltic pump which pumps blood through the disposable set.
- Pre-filter line: the pre-filter line connects the outlet of the blood pump segment to the filter or cartridge blood inlet. It includes a filter pressure pod. In between, the pre infusion and systemic anticoagulation lines connect to the pre filter line.
- Filter blood compartment: blood flows in the hollow fiber membrane, which constitute the blood compartment of the filter, from bottom to top to minimize air trapping. The output of the blood compartment connects to the deaeration chamber.
- Deaeration chamber: the deaeration chamber is connected to the return line section downward the filter, the monitor line and the return line. It also connects with the post infusion line. Blood flows in and partially fills the chamber. Due to the centrifuge flow, air that might be in the blood flowing out of the filter travels upwards out of the fluid to the air filled portion. The monitor line connects to the return pressure port and permit to measure the return pressure. Degassed blood flows in the return line.
- Return line: the return line connects the deaeration chamber to the patient catheter. It passes through the air bubble detector and return clamp.

The **PrisMax** fluid path includes:

- Pre-blood pump fluid line: this connects the pre-blood pump (PBP) from the pre-blood bag to the access line connection.
- Systemic syringe line: this connects the anticoagulant being delivered from the systemic syringe into the pre-filter line.

- Pre-filter replacement line: this line connects from the fluid in the bag on the replacement scale to the pre-filter line.
- Dialysate line: this line connects from the fluid in the bag on the dialysate scale to the filter fluid compartment input.
- Filter fluid compartment: the dialysate line connects to the input of the filter fluid compartment. Conversely to the blood path, the filter fluid compartment flows from top to bottom. It gives the fluid the chance to meet with the blood through the fiber membrane and transport impurities from the blood to the fluid filter compartment. The output of the filter fluid compartment connects to the input of the effluent line.
- Effluent line: the fluid coming out of the filter fluid compartment flows into the input of the effluent line. It flows through a pressure pod, the discharger ring, and the blood leak detector. The output of the effluent line is either the effluent catch bag on the effluent scale, or the input to the auto-effluent accessory.
- Post-filter replacement line: this line connects fluid from the bag on the replacement scale to the deaeration chamber.
- Auto Effluent line: when used, the effluent line described above connects to the auto effluent accessory and the auto effluent bags. The auto effluent drain line routes fluid from the auto effluent bags to the clinical drain.



### **WARNING!**

Always connect the return line directly to the blood access device. Do not connect additional devices between the return line and the blood access device. Using additional devices (such as three-way valves, stopcocks, or extension lines) can impede the detection of return disconnections, potentially resulting in severe blood loss.

## Blood access

A dual-lumen veno-venous central access device is the most common blood access method. Two single-lumen venous catheters can also be used for blood access.

In certain circumstances, arterial blood access via arterio-venous (A-V) fistula may be desirable. Blood access may also be via an external blood access device connected to the Prismaflex disposable set. In some situations, blood return is via a single lumen venous catheter or a large peripheral vein.

Possible patient locations for the blood access are the jugular, subclavian, or femoral vein. Follow hospital policy to select the blood access site most appropriate for the patient.

Sometimes arterial blood access via arterio-venous (A-V) fistula may be appropriate. Blood access may also be via an external blood access device connected to the disposable set. In some situations, blood return is via a single-lumen venous catheter or a large peripheral vein.

Adapt the size of the catheter to both the patient and the blood flow rate prescription for extracorporeal therapy.

An insufficient catheter-blood flow combination can lead to very negative access pressure, a very positive return pressure, or both. This might make associated alarms go off frequently. If this happens, consider reducing the blood flow rate or changing the vascular access to a larger catheter.

An insufficient catheter-blood flow combination can also result in access or return pressure close to zero. This prevents the system from sensing a disconnection at the vascular access. If this happens, consider increasing the flow rate or changing the vascular access to a smaller catheter.

**WARNING!**

Operator must monitor vascular access connection for air ingress and blood loss.

## Pressure monitoring

The **PrisMax** system monitors the pressure in the access, filter, return, and effluent lines. This monitoring identifies unusual pressure conditions such as extreme positive pressure in the return line or disconnection.

The machine also uses the pressure data to calculate filter pressure drop ( $\Delta P$ ), and transmembrane pressure (TMP) or access transmembrane pressure (TMPa). These calculated pressures are used to tell when clotting has begun in the filter or when the filter has clotted and the set must be changed.

Pressures change within the set depending on individual patient blood properties, the size of the patient vascular access, flow rates, and the therapy in use. During a treatment the screen shows all the monitored pressures.

For pressure trend information, tap the **History** button in the toolbar. This shows a line graph of pressures over a selectable period. See "History", page 14 for more information about the user interface.

### **Access, filter, and effluent pressure monitoring**

To monitor pressures in the access line, filter, and effluent line, the machine uses both pressure pods and direct pressure measurement.

Pressure pods are part of disposable sets, and include pressure pods at the access line (access pod), filter inlet (filter pod), and effluent line (effluent pod).

Pressure sensor housings on the front panel of the control unit holds the access, filter, and effluent pressure pods. The housings connect the pressure pods to the pressure sensors inside the control unit.

Each pressure pod has a fluid compartment and an air compartment. The compartments are separated by a flexible diaphragm that normally is in the middle of the pod at the pressure-neutral position. During patient treatment, the fluid compartment of the pod fills with fluid that flows through its attached line. Changes in fluid pressure move the diaphragm and compress or expand the air compartment. The pressure sensor turns these pressure changes to electrical signals, which system software interprets as pressure values.

The software includes fixed pressure limits to ensure patient safety. If a monitored pressure goes outside these limits, an alarm goes off, and the machine takes appropriate safety measures. Safety measures can include stopping one or more pumps and closing the return line clamp.

Extreme pressure default limits for CRRT

Table **Extreme pressure default limits for CRRT**

| Pressure limit | Alarm                     |
|----------------|---------------------------|
| +450 mmHg      | High Filter Pressure      |
| +350 mmHg      | Return Extremely Positive |
| +450 mmHg      | Access Extremely Positive |
| +10 mmHg       | Return Disconnection      |
| 0 mmHg         | --                        |
| -250 mmHg      | Access Extremely Negative |

## Return pressure monitoring

To monitor pressure in the return line, the machine uses the following components:

- deaeration chamber - placed on the return line of the disposable set
- chamber monitor line - part of the deaeration chamber, and connects the top portion of the deaeration chamber to the return pressure port. The chamber monitor line contain a hydrophobic filter to act as a protection to keep blood from reaching the return pressure port.
- return pressure port - placed on the front panel of the control unit, and connects to the chamber monitor line using a luer-lock
- return pressure sensor - placed inside the control unit, behind the return pressure port

During patient treatment, blood flows from the outlet port of the filter and into the return line, then into the deaeration chamber on the return line. The chamber receives any post-filter replacement solution in use. Fluid in the chamber then flows into the deaeration chamber in the return line leading to the patient.

The top-most portion of the deaeration chamber is air-filled and connected to a pressure sensor inside the control unit via the chamber monitor line to the return pressure port.

The return pressure sensor monitors changes in the return pressure.

Table **Pressure monitoring**

|                       |  |
|-----------------------|--|
| Access pod pressure   | Can be negative or positive, depending on access line connection: <ul style="list-style-type: none"> <li>• The patient central venous catheter is typically negative</li> <li>• The external blood access device or patient A-V fistula is typically positive</li> </ul> |
| Return pressure       | Typically positive   |
| Filter pod pressure   | Typically positive and the highest pressure in the set, immediately before the filter  |
| Effluent pod pressure | Can be positive or negative, depending on the ultrafiltration rate, condition of the filter membrane, and therapy in use   |

## Pressure Operating Points

During therapy the software stores a reference pressure value for each pressure pod and the return line sensor. This value is called the pressure operating point. The machine continually compares the current pressure at each monitoring site with the reference value to sense changing pressure conditions.

Pressure operating points are first set shortly after treatment begins. The points are set when pumps have the correct rate and the blood flow through the set is stable. Some pressure alarms, for example, TMP-related alarms, are disabled until operating points are set. The time at which the first operating points are set depends on the operator-set blood flow rate and the filter blood volume.

To maintain pressure monitoring accuracy during treatment, the machine updates pressure after any of the following happens:

- blood flow rate change
- blood pump restart
- alarm reset
- pinch valve position change
- self test

## Derived Pressure Displays

The software uses monitored pressure values to calculate vital pressure conditions such as filter pressure drop ( $\Delta P$ ) and other parameters applicable to the therapy in use. This pressure information is used to notify about clotting or membrane pore plugging (clogging) in the filter and, if extensive enough, notify that a change of set is required.

# Fluid management

## About fluid management

The **PrisMax** system uses pumps, scales, solution bags, and software to ensure correct fluid balances.

## Pumps and scales

The fluid pump controllers set the set pump flows using feedback from the weight scales. The peristaltic pumps are positive-displacement occlusive pumps. The scales are color coded to match the disposable lines and onscreen information.

Depending on the prescribed therapy, the machine controls the following solution pumps:

- The **Pre-Blood Pump (PBP)** infuses solution into the access line after the patient blood enters the access line and before the blood pump, diluting the blood as it enters the set. To maintain the set blood flow, software increases the blood pump flow to take in the PBP flow. Blood pump flow = set blood flow + PBP flow in milliliters per minute, ml/min.
- The **Dialysis pump** infuses dialysate solution into the filter fluid compartment, or infuses replacement solution into the return line post filter depending on prescribed therapy. A pinch clamp selects the dialysate flow into the filter fluid compartment or return line.
- The **Syringe pump** infuses syringe solution for precise delivery in continuous micro-boluses. The syringe pump also delivers an immediate bolus upon request. The selected anticoagulation method gives the syringe pump connection. The system makes sure that changes in infusion rates or a bolus delivery does not have an effect on the accuracy of the system.
- The **Replacement pump** infuses replacement solution into the flow path. Depending on prescribed therapy, the pump infuses solution into the flow path pre filter, post filter, or both. This is set by a pinch clamp.
- The **Effluent pump** removes fluid to balance the fluids added by the other pumps. If additional patient fluid removal (PFR) is selected, the effluent pump removes more fluid than required to maintain balance. The speed of the effluent pump gives the filtration rate.

The machine controls the speed of the pumps to maintain the set flow rates, based on the changing weight of the solution bags. The software adjusts the pump flow rates to get the prescribed patient fluid removal (PFR). This way the machine can compensate for treatment interruptions and maintain the target fluid removal. Patient fluid removal makeup is limited to 20% of the prescribed patient fluid removal or 2 ml/kg/h × patient weight in kg, whichever is less.

Flow rates are set by the user or the software. Users can for example set the dialysate, or replacement solution flow rate. The software calculates the flow rate based on the flow and anticoagulation settings. For example, the effluent flow rate is automatically set to keep a net zero fluid balance if PFR is set to zero, in which the volume infused into the patient is removed from the patient.

All pumps turn clockwise during a treatment. If an alarm goes off that would stop the fluid pumps, for example a bag change, the blood pump continues to run to minimize the risk of clotting in the set. If an alarm stops the blood pump, all other pumps also stop. When the blood pump continues, the other pumps also continue shortly afterwards.

## Solution bags

The **PrisMax** system is validated to operate with Baxter solution bags. The expected standard size for dialysate, PBP, and replacement solution bags is five liters. If using dialysate or solution bags other than those manufactured by Baxter, ensure the bags hang correctly on the scales. Standard effluent bags used in CRRT are available in volumes of five and nine liters. When using a bag, make sure of the following:

- The bag hangs free of contact of the control unit housing, the base, and any bags hanging next to it.
- The connected disposable set lines are not kinked, hang freely from the housing or base, and do not prevent bags from hanging freely.
- The bag perforations align with the three hooks on the removable carrying bar. This will ensure proper scale function.

The machine stops and shows an alarm message when it is time to change the bag or container. This reduces the possibility of drawing air into the flow path. The machine calculates when it is time to change the effluent bag based on the selected bag size.

## Empty bag detection

The machine senses a bag as empty when the bag weight reaches the predefined lower limit. The default limit is 230 g. A Bag Empty alarm goes off when the machine senses an empty bag. This method is validated for Baxter supplied bags.

## Auto Effluent (AE) accessory

The Auto Effluent (AE) accessory (also referred to as Auto Effluent Drain) points effluent flow into one of two effluent bags. This allows effluent to flow into one bag while the other bag drains. This makes it unnecessary to change effluent bags during treatment.

The AE accessory is indicated for application for a maximum of 6 days or 560,000 pump revolutions, whichever come first. The expected life is calculated based on the current maximum effluent pump volume or effluent pump rate. Change the auto effluent accessory when changing the front disposable set. If the expected life of the auto effluent accessory is less than the new filter set, remove the auto effluent accessory during end treatment. See chapter Accessories for more information on accessories.

## Fluid balance

The **PrisMax** software senses flow problems in fluid lines, bags, or pump segments that can cause errors in the patient fluid balance. The scales continuously monitor the weight of the PBP, dialysate, replacement, and effluent bags. During operation, software compares actual bag weights to their expected weights. The expected weights are continually computed, based on the set flow rates. Software monitors the speed of PBP, dialysate, replacement, and effluent pumps, and compares them to the expected speeds.

The volume of syringe flow is automatically removed as it is delivered. If the fluid pumps pause because of a bag change, the syringe flow volume is removed when fluid pumps resume.

If the **PrisMax** senses a possible fluid balance problem, it stops treatment and a fluid balance alarm goes off. The system then stops all fluid pumps, while the blood pump continues to circulate the blood through the flow path.

The alarm message includes possible causes and corrective actions for the alarm, and an illustration shows the possible cause. It is important to find and correct all possible causes before resetting the alarm and restarting fluid pumps. Unresolved or repeated fluid balance alarms can result in fluid losses or gains in the patient, and cause ending of the therapy.

# Air management

## About air management

**PrisMax** includes a deaeration chamber to minimize air bubbles in the flow path. The air detector, downstream of the chamber, detects any remaining air over 20 microliters (µl). Baxter recommends using a post-replacement infusion whenever possible. This extra layer of infusion fluid at the top of the chamber prevents an air-blood interface and minimizes clotting.

Some actions during treatment can add a small amount of air into the set and change the fluid level in the deaeration chamber. The machine uses the Liquid Level Sensor (LLS) in the chamber holder to check the fluid and adjust or warn appropriately. The system automatically lowers the fluid level if it gets to the upper sensor. It is possible to manually adjust the fluid level if needed via the Adjust Deaeration chamber functions under the **Tools** button.

The set has a fluid protection barrier above the deaeration chamber for continuous pressure monitoring and air adjustment. The fluid barrier prevents contamination of the return pressure sensor. If the fluid barrier gets wet, it no longer allows air to flow back and forth as pressure changes in the chamber. **PrisMax** continuously tests for fluid barrier wetting. Change the set if this happens.

## Foam management

Sometimes a lot of foam is formed at the top of the deaeration chamber. When this happens, some foam may reach the fluid barrier in case of sudden return access blockage and pressure increase. It may then be appropriate to consider increasing the post-replacement infusion rate to reduce the amount of foam. Because foaming can be a result of an air leak in the set, it is important to inspect the set for leaks, especially at joints on the access line. These joints are the luer connection, sample port, replacement line, and PBP line.

# Anticoagulation

## About anticoagulation

Coagulation starts when a patient's blood gets into an extracorporeal circuit. Because of this, effective anticoagulation is necessary to optimize fluid and solute removal, and filter longevity. Little or no anticoagulation may be needed for patients with coagulopathies, thrombocytopenia, or liver failure.

Anticoagulation is administered during treatment according to physician prescription. The following methods are included:

- None for treatments with no anticoagulation. The syringe pump is disabled.
- Systemic anticoagulation for treatments with systemic anticoagulation delivered by the syringe pump.

Avoid starting blood recirculation following an alarm or bag change, as the amount of citrate in the blood can be too low at this point to provide enough anticoagulation.

The therapy set which anticoagulation methods are available.

- CRRT: None, Systemic anticoagulation
- TPE: None, Systemic anticoagulation

During Setup, the operator can set an anticoagulation advisory reminder. This will remind the operator about the anticoagulation at set intervals. Tap the **Operating Mode** button during treatment to view the current settings.



### **CAUTION!**

Any changes to syringe configuration must be performed by a trained and qualified service technician at installation.

**CAUTION!**

To ensure proper flow control of syringe solution, use only the syringes approved for use with the **PrisMax** system. The internal diameter of approved syringes has been verified at the time of printing this manual. Baxter cannot be held liable for subsequent changes that may occur to syringe dimensions.

**CAUTION!**

Closely monitor the patient's clotting parameters, especially when changing the amount of anticoagulant delivered, after changing the prescribed therapy setting, or after changing the syringe.

**CAUTION!**

Consider syringe accuracy specifications when using highly-concentrated anticoagulant solutions.

**CAUTION!**

Keep the syringe line clamped and stowed along the left side of the set cartridge during the entire treatment when not in use.

**NOTE!**

Due to manufacturing variation of the syringe suppliers, a selected syringe can cause syringe alarms to frequently occur. If this happens, consider the use of an alternative syringe brand.

## Components

The **PrisMax** system includes the control unit, **PrismaFlex** disposable set, disposable solutions, and optional accessories. Sets, solutions, and accessories are purchased separately.

The **PrisMax** system includes a color touchscreen Graphic User Interface (GUI) that simplifies the entry, observation, and control of patient and treatment information. The GUI includes a high-visibility status light, and rotates and tilts for optimal viewing.

The control unit automatically loads and primes disposable sets. Disposable sets include a filter, pressure pods, and tubing lines for the blood and fluid flow paths. An optional auto effluent (AE) accessory fills and drains the effluent bags, eliminating the need to drain or change

effluent bags during therapy. The **PrisMax** software monitors how long a set is in use, and activates a reminder alarm when the set reaches its maximum life.

The ergonomic design of the control unit includes scales and bag hooks that are positioned for convenient solution bag handling. Electronically controlled solution pumps, scales, and pressure sensors provide precise delivery and monitoring. Scales and tubing lines are color coded for convenient identification.

The blood pump, located at the center of the front panel, draws the patient's blood into the access line, pumps it through the filter and tubing, then returns the blood to the patient

( "PrisMax overview (without AE accessory)", page 249).

The exact mechanism by which fluid or solutes are filtered from the blood depends on the therapy in use. Filtered blood then travels from the filter to the deaeration chamber, which removes air that may be trapped in the blood. A Liquid Level Sensor (LLS) measures the blood level in the chamber and triggers an automatic adjustment of the fluid level. An Air Bubble Detector (ABD) detects if any air remains. If the ABD detects air, an alarm activates, the pumps stop, and the return line clamp closes to prevent air from being returned to the patient.

The Blood Leak Detector (BLD) in the effluent line allows the system to detect the presence of red blood cells that could indicate one or more broken fibers in the filter membrane.

The **PrisMax** system includes a syringe pump that supports the use of systemic anticoagulation.

- In systemic anticoagulation, the anticoagulant, for example heparin, is delivered into the access line after the blood pump and before the filter by the syringe pump.

Pressure sensors at the access, filter, effluent, and return lines monitor the flow path for abnormal pressures that could indicate a disconnected or occluded line. Pressure sensors also monitor the clotting status of the filter.

The **PrisMax** system monitors solution scales to ensure all bag weights change at expected rates, and provides notification when solution bags are nearly empty, or when the effluent bag is nearly full.

A leak detector at the base of the control unit continuously monitors for fluid leaks.

Connectors—Ethernet, USB, Serial, and Remote Alarm—on the back panel of the control unit allow data collection and extended monitoring.

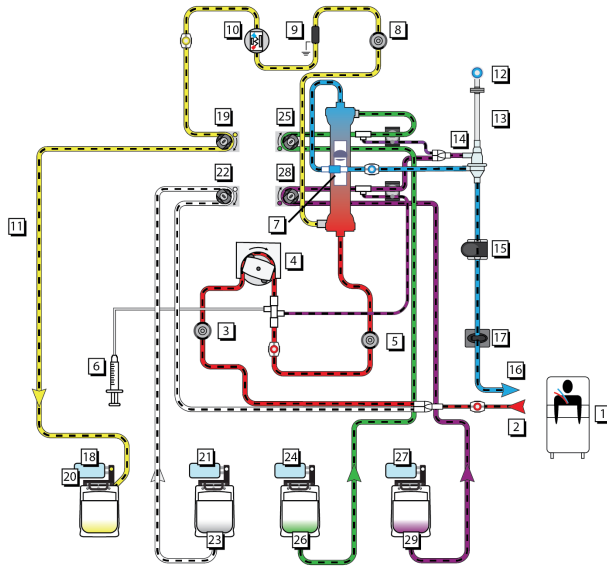

Figure PrismaMax overview (without AE accessory)

- |                               |   |
|-------------------------------|---|
| 1. Patient                    | 2. Access line                                    |
| 3. Access pressure pod        | 4. Blood pump                                     |
| 5. Filter pressure pod        | 6. Syringe pump                                   |
| 7. Filter                     | 8. Effluent pressure pod                          |
| 9. Discharger ring            | 10. Blood Leak Detector (BLD)                     |
| 11. Effluent line             | 12. Return pressure port                          |
| 13. Monitor line              | 14. Deaeration chamber/ Liquid Level Sensor (LLS) |
| 15. Air Bubble Detector (ABD) | 16. Return line                                   |
| 17. Return line clamp         | 18. Effluent scale                                |
| 19. Effluent pump             | 20. Effluent bag                                  |
| 21. PBP scale                 | 22. PBP pump                                      |
| 23. PBP solution              | 24. Dialysate scale                               |
| 25. Dialysate pump            | 26. Dialysate solution                            |
| 27. Replacement scale         | 28. Replacement pump                              |
| 29. Replacement solution      |   |

# Control unit

The software-controlled control unit does the following:

- Automatically loads and primes the disposable set
- Pumps blood through the blood flow path of the disposable set
- Delivers anticoagulant solution into the flow path
- Pumps sterile infusion solutions into the blood flow path according to the therapy in use
- Pumps sterile dialysate into the fluid compartment of the filter, if required for the CRRT therapy in use
- Controls the patient fluid removal according to the therapy in use
- Monitors system and alarms for any abnormal occurrence
- Automatically empties fluid from effluent bags if the auto effluent (AE) accessory is in use
- Includes a color touchscreen display that rotates and tilts for optimal viewing

The control unit also includes an independent manual Stop button

**WARNING!**

Operator must only use the manual Stop button in the event the touchscreen becomes unresponsive.

Local regulations may restrict the availability of some therapies, options, or accessories. Contact your local Baxter representative for complete ordering information.

The **PrisMax** control unit and required installation accessories are packaged together, including the following:

- The control unit is pre-attached to the standing column and a base with casters. The blood-pump crank and the 50-ml syringe clip are also attached to the control unit.
- The installation kit includes power cords, retaining bracket, 4 retaining bracket screws, and 4 removable bag scale handles.
- Potential equalization conductor kit

- 20-ml syringe clip
- Caution stickers
- Other documents, determined by local regulatory requirements. The operator's manual and ancillary supplies are shipped separately.

## Power control panel

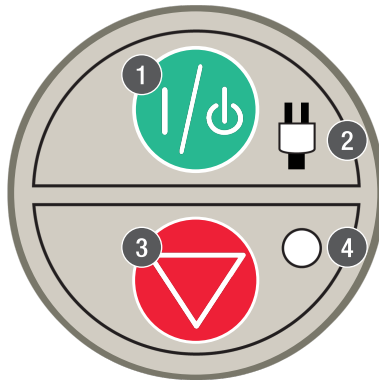

Figure Power control panel

- 1. On/standby button** Turns the control unit on or places it in standby. Press and hold the button to turn the unit on. On: The display and all electronics are on. Standby: All electronics are off, except for power supply and battery charging. To completely remove power from the system, disconnect the AC plug from the wall when the device is in standby. To power off the **PrisMax** system press and hold the green power button for a couple seconds. The software will detect the button press and perform a shutdown. If the **PrisMax** system does not respond to this, and seems completely non-responsive, press and hold the button until the **PrisMax** system shuts down. After this, the **PrisMax** may be powered back up again.
- 2. Power indicator (green)**  
Alternating current (AC) or battery power connected to the control unit.

3. **Stop button** Stops the control unit that stops all motors and closes the return clamp. This provides an independent way to stop the device.

4. **Stop indicator (yellow)** Control unit is stopped. All motors are stopped.

## Pumps

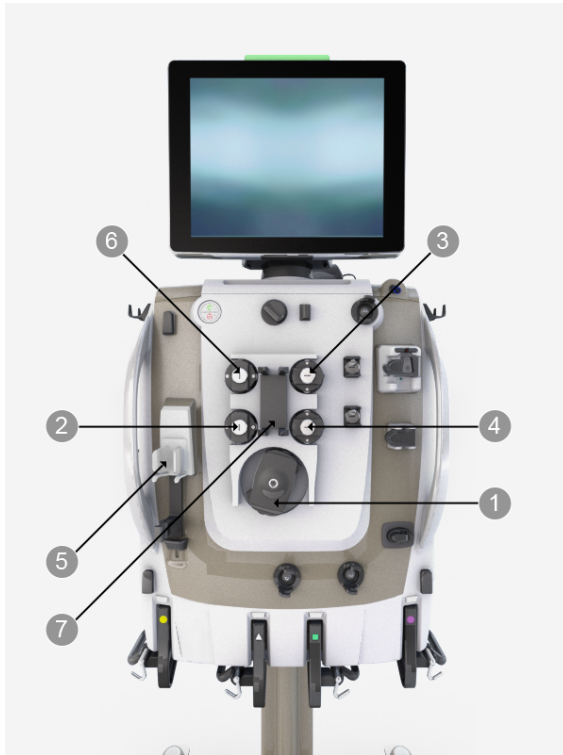

Figure Blood and solution pumps

1. **Blood pump** Pumps blood through the blood flow path of the disposable set.

2. **Pre blood pump (PBP)** Pumps solution into the blood access line at a location after patient blood enters the line and before the blood pump.

3. **Dialysate/replacement 2 pump** CVVHD, CVVHDF: Pumps dialysate solution into the fluid compartment of the filter. CVVH: If post-filter replacement delivery is selected and replacement solution is on the green scale, pumps replacement solution into the post-filter blood-flow path.

4. **Replacement pump** Pumps replacement solution into the blood-flow path. Replacement solution can be delivered pre- or post-filter.

5. **Syringe pump assembly** Holder for a solution-filled syringe and controls the delivery rate of the solution. Delivery is continuous or in boluses. Systemic anticoagulation: Syringe pump delivers anticoagulant into the blood flow path between the blood pump and the filter. The syringe line on the disposable set is stowed along the left side of the set cartridge.
6. **Effluent pump** Pumps ultrafiltrate/dialysate. Controls ultrafiltration rate based on settings for patient fluid removal (PFR) rate, PBP, dialysate, replacement, and syringe flow rates.
7. **Loader** Loads set during Setup, unloads during End mode, and retains set during Therapy.
- **Pump raceway** The tubing pathway into which the pump segments of the disposable set are loaded.
  - **Rotor** The rotor is the center component of each peristaltic pump that rotates during pump operation. Holds two spring-loaded rollers that occlude the pump segment in the raceway. Occlusion moves the fluid in the pump segment forward in discrete amounts and prevents backflow.

## Left side panel and drip tray

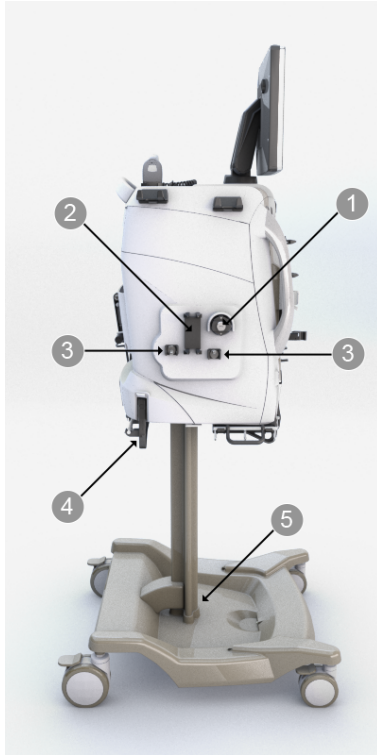

Figure Left side panel and drip tray

### 1. Auto Effluent (AE) pump

Pumps effluent to a drain from the dual-effluent bag system. The auto effluent accessory uses two effluent bags: one bag empties to the drain while the other bag fills with effluent.

### 2. Auto Effluent (AE) loader

Loads the auto effluent accessory during Setup, unloads during End mode, and retains the accessory during Therapy.

3. **Auto Effluent (AE) pinch valves (left and right)** The left auto effluent pinch valve controls which bag is being filled, and switches effluent bags whenever the scale determines that 1 liter of effluent has been added. The right auto-effluent pinch valve controls which bag is being emptied. While effluent flows into one bag, the other bag empties to the drain and is emptied when effluent flow switches bags. If the drain is unavailable, effluent flows into both bags until drain use is restored.
4. **Auto Effluent (AE) scale**  
Auto-effluent bag with less capacity hangs on this scale, that is indicated by a yellow circle.
5. **Drip tray** Collects leaked fluid. An alarm goes off if leaked fluid accumulates past a fixed limit.

# Pressure sensors and deaeration chamber holder

## About pressure sensors and deaeration chamber holder

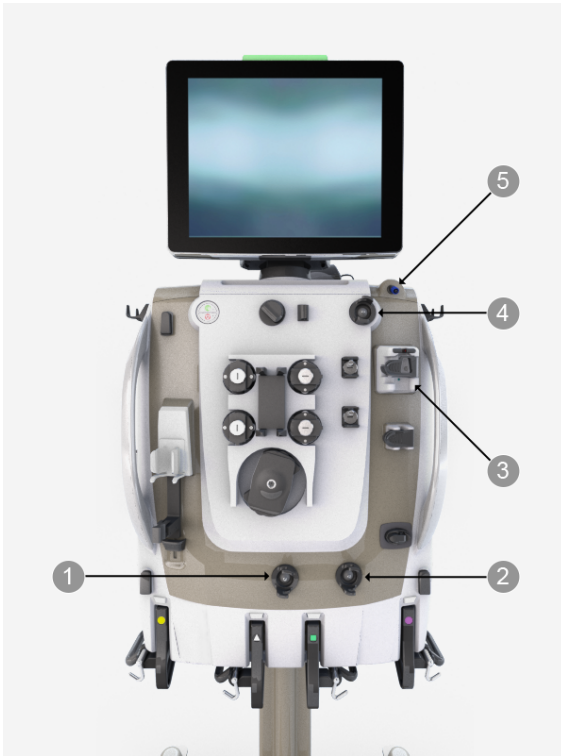

Figure Pressure sensors and deaeration chamber holder

- |   |   |
|---|---|
| <p>1. <b>Access pressure sensor</b> Enables non-invasive monitoring of access line pressure. There are no air-fluid interfaces, and the disposable set's flexible pod diaphragm prevents blood from contacting the pressure sensor.</p> | <p>2. <b>Filter pressure sensor</b> Enables non-invasive monitoring of filter line pressure. There are no air-fluid interfaces, and the disposable set's flexible pod diaphragm prevents blood from contacting the pressure sensor.</p> |
|---|---|

3. **Deaeration chamber holder/Liquid Level Sensor (LLS)/Foam Detector** Holds the deaeration chamber of the disposable set and maintains the liquid level between an upper and lower position. Permits degassing of air bubbles from the blood and fluid before entering the return line. The sensor detects if foam is present in the line above the daeration chamber.
4. **Effluent pressure sensor** Enables non-invasive monitoring of effluent line pressure. There are no air-fluid interfaces, and the disposable set's flexible pod diaphragm prevents fluid from contacting the pressure sensor.
5. **Return pressure port** Connects to the deaeration chamber pressure monitor line on the disposable set. A fluid barrier at the distal end of the monitor line protects the return pressure sensor from accidental blood entry. Enables non-invasive monitoring of return line pressure.

Because pressure diaphragms can move slightly out of neutral position during normal operation, an internal automatic reposition system (ARPS) resets all diaphragms to their neutral positions and verifies correct pressure sensor operation at least every two hours. The Liquid Level Sensor (LLS) positions the blood level at an optimal level in the deaeration chamber prior to the start of the treatment, and during operation at least every two hours.



**WARNING!**

Do not remove pressure pods during therapy.



**WARNING!**

Monitor pressure during treatment.

## Access, filter, and effluent monitoring

Disposable sets have pressure pods on the access line, at the filter inlet, and on the effluent line ( "Pressure pod installed in sensor housing (effluent line shown)", page 258). The front panel of the control unit has sensor housings, each containing a pressure sensor, that accommodate the pressure pods.

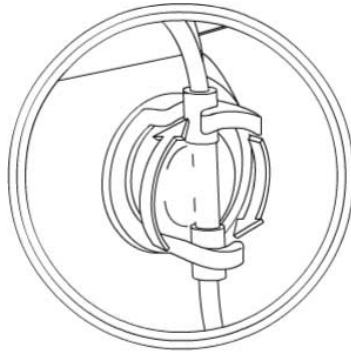

Figure Pressure pod installed in sensor housing (effluent line shown)

Each pressure pod in the disposable set has a fluid compartment and an air compartment. The compartments are separated by a flexible diaphragm, which normally rests in the neutral pressure position.

During treatment, the fluid compartment of each pod fills with the fluid from the applicable line. Fluid pressure fluctuations move the diaphragm, compressing or expanding the air compartment. The pressure sensor behind each pod converts these pressure fluctuations to electrical signals, and the **PrisMax** software uses the signals to compute the pressure value.

## Return monitoring

During a patient treatment, blood flows from the filter outlet, into a short portion of the return line, and then into the deaeration chamber on the return line ( "Deaeration chamber", page 258). The deaeration chamber also receives post-filter replacement solution, if used. Fluid from the deaeration chamber flows into the final portion of return line leading to the patient.



Figure Deaeration chamber

The top-most portions of the deaeration chamber and chamber monitor line are filled with 1 to 2 ml of air. Fluctuations in the pressure exerted by this column of air are received by the pressure sensor located behind the return pressure port ( "Return pressure port", page 259). The return pressure sensor is protected from potential contamination by the protective membrane fluid barrier supplied with the set.



Figure Return pressure port

## Pinch valves, return clamp and detectors

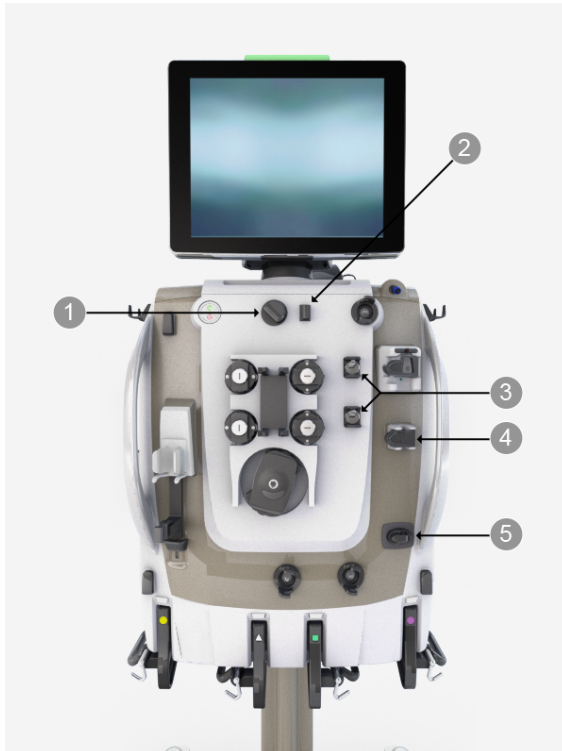

Figure Pinch valves, return clamp, and detectors

**1. Blood Leak Detector (BLD)**

The Blood Leak Detector continuously monitors for a change in opacity in the effluent line due to red blood cells, dissolved particulates or a change in color, which can indicate a leak in the filter membrane. The system continuously examines the strength of the infrared transmission signal received across the effluent line.

**3. Pinch valves (upper and lower)**

The upper pinch valve accepts tubing from the dialysate/replacement 2 pump (CVVH, CVVHDF). The lower pinch valve accepts tubing from the replacement pump. The valves open and close automatically to allow pre- and post-filter options for delivering replacement solution.

**5. Return line clamp**

The return line clamp closes to prevent blood or air from passing to the patient. The clamp automatically closes when power is off, during some self-tests, or in case of a possible patient safety hazard. Installing tubing under the clamp engages a tubing detection switch.

**2. Discharger ring guide** Holds the disposable set discharger ring, which is designed to discharge electrostatic voltage in the disposable set. These electrostatic charges are not hazardous to the patient, but can appear as artifacts on cardiac monitors. Always install the discharger ring into the guide before connecting a patient to the disposable set.

**4. Air Bubble Detector (ABD)** An ultrasonic transmission/detection device continuously monitors the return line for air bubbles. If a bubble is detected, an alarm goes off. Installing the return line engages a tubing detection switch.

## Front scales



Figure Front scales

- |  |  |
|--|--|
| 1. <b>Effluent scale</b> (yellow circle) | 2. <b>PBP scale</b> (white triangle)         |
| 3. <b>Dialysate scale</b> (green square) | 4. <b>Replacement scale</b> (purple octagon) |

The **PrismaMax** software monitors the weight of each fluid bag to precisely control solution flow rates and patient fluid removal. There is an alert when a solution bag is nearly empty or when the effluent bag is nearly full, and color coded LEDs on the scales light when a bag change is required.

The scale is open when it is pulled away from the control unit, and closed when completely pushed in. During normal operation, an alarm goes off if a scale is open, and the screen shows which scale is open using the color and shape code for the scale.

Each scale holds a removable carrying bar with three hooks. Use one of the side hooks on the control unit for support when attaching or removing bags. Always hang a fluid bag centered on the three-hook

assembly to distribute its weight evenly. When the carrying bar on the scale is replaced, rotate the handle toward the floor, and close the scale.

## Miscellaneous components

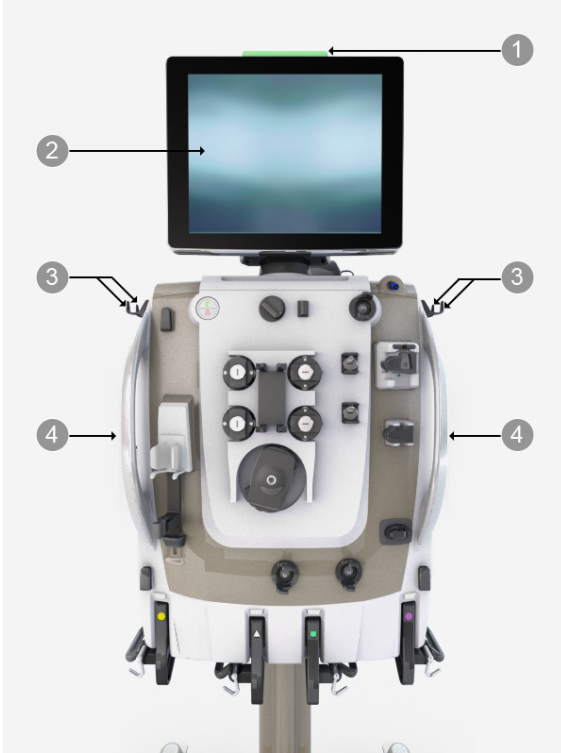

Figure Miscellaneous components

1. **Status light** Lights up to give a general indication of operating conditions. Green: Normal operation, treatment in progress, or information text is present when patient is not connected. Yellow solid: When a patient is connected, indicates a low-priority alarm, that is, patient safety hazard not indicated but investigation required. Yellow flashing: Medium-priority alarm. Prompt attention required. Red: High-priority alarm, possible patient hazard. Immediate clinician intervention required.
2. **Display** Rotates and tilts to show operation, alarm, and help instructions. Press onscreen buttons to change settings, start and stop functions, and navigate between screens.

3. **Side hooks** May be used to hang bags.

4. **Handles** Use the handles on the side and back to move the control unit as needed.

## Back panel

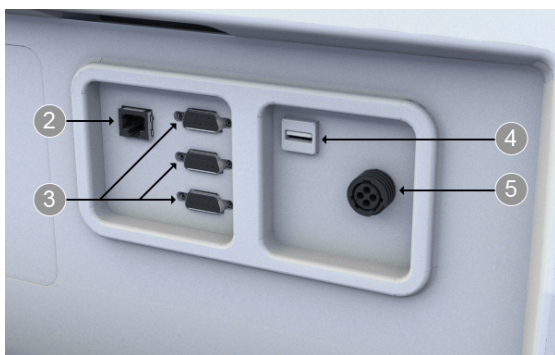
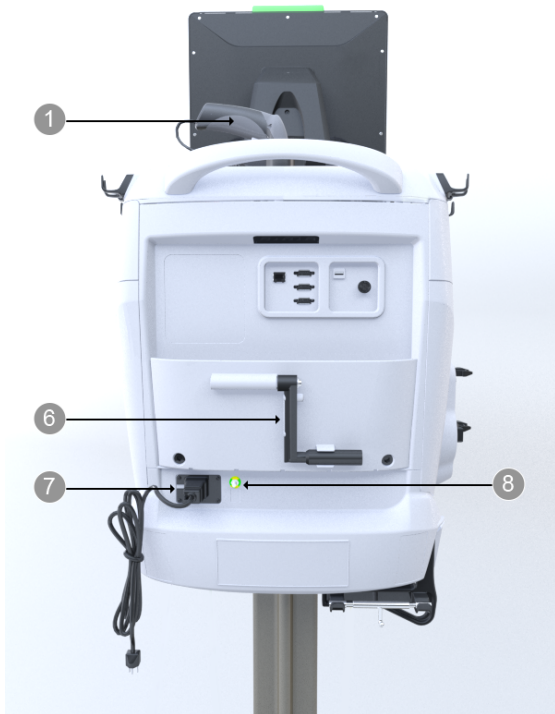

Figure Back panel components

1. **Barcode reader** Reads the barcode, 1D or 2D, on the disposable set before or after unpackaging the set. This information allows software to use the correct default flow-rate ranges, pressure alarm limits, and priming sequence for the set. Can also read patient ID.
  2. **Ethernet connector** An IP-addressable port for data exchange with a personal computer or BAXTER service site, software upgrade, or communication network.
  3. **Serial ports** Connections for data exchange with a personal computer, communication network, or modem.
  4. **USB port** Connection for data download, software upgrade, or other information.
  5. **Remote alarm (nurse call) connector** Connects an optional remote alarm. Connected equipment must comply with IEC 60601-1 requirements.
  6. **Pump crank** Allows manual pump operation to return blood to patient or to turn fluid pumps. The handle contains a ratchet that forces the blood pump rotation in the correct direction.
  7. **Power socket** Power cord socket: AC power connection. Includes two fuses. Power cord retainer: Protects against accidental power cord disconnection.
  8. **Equipotential connector** Ground point.
- **Inside back panel** Speaker: Sounds a continuous or intermittent beep for certain alarm conditions. Fan: Cools device interior. The inside back panel is not shown of pictures.

## Remote screen viewing

The remote screen feature allows a viewer using a standard VNC client to connect to the **PrisMax** system and view the screen display on their remote computer or mobile device.

Network and **PrisMax** security is maintained through the need for a person at the **PrisMax** with the proper PIN to begin the process, and the rejection of any incoming commands through VNC by the **PrisMax** software.

Patient security and safety is maintained through the restriction of treatment once the remote screen server is started. In order to remove the restriction against treatment, the **PrisMax** system must be powered off.

The sequence of viewing the screen are as follows:

1. At the New Patient screen, enter system configuration by tapping the gear icon.
2. Identify yourself as an authenticated user by logging in at the Admin privilege.
3. Tap connectivity and scroll to the bottom of that page.
4. Tap the **Start Server** button.
5. A dialog will appear with the network address of the **PrisMax** system. Give this address to the user with the VNC client and have the VNC client connect to this address.
6. A connection request dialog will replace the initial dialog.
7. The network address of the requesting VNC client will appear. Verify that this address is that of the proper user connecting in step 5.
8. Tap the accept button if the address is from the proper user.
9. The VNC client will begin to show the current screen.
10. Exit from system configuration to go back to the normal **PrisMax** screen.

**NOTE!**

A slight delay (0.5 seconds or so) may happen between changes on the **PrisMax** system screen and the corresponding change on the VNC client screen.

## On device training

The **PrisMax** System has the capability to deliver on-device training through offline content on a USB device. This allows for a guided on-device training approach, with the additional safety feature that no pumps will turn while the USB is inserted.

Contact your Baxter local representative for more details.



## Chapter 7

# Sets and accessories

### **Disposable sets** **269**

---

- About disposable sets ... 269
- Low-flow and high-flow sets ... 270
- Minimum patient weight ... 270
- Disposable set description ... 271

### **Blood warmers** **275**

---

- About blood warmers ... 275
- Enabling blood warmers ... 276
- TherMax blood warmer ... 276
- PrismaTherm II blood warmer ... 278
- PrismaComfort, PrismaFlo II, and PrismaFlo IIS blood warmers ... 280

### **Auto Effluent (AE) accessory** **281**

---

### **Other accessories** **282**

---



# Sets and accessories

## Disposable sets

### About disposable sets

**NOTE!**

For disposable set specifications see "Disposable set specifications", page 321.

The disposable set Instructions for Use (IFU) provide information including operating flow rates, filter pressures, priming requirements, and performance data. The **PrisMax** system accommodates single-use disposable sets that include the following:

- A cartridge that attaches to the loader on the front panel of the control unit. The cartridge includes the lines, pump segment tubes, and filter.
- A pre-connected blood-flow path.
- Pre-connected flow paths for PBP, dialysate, replacement, and effluent solutions, depending on the set type.

The barcode reader on the control unit can read the barcode on the back of the disposable filter set before or after unpackaging. The barcode reader can also scan the barcode on the AE accessory set. If the barcode is unreadable, the set can be selected from a drop-down list.

Follow the onscreen instructions to confirm the set type, which determines default flow rate ranges, alarm limits, and priming sequence for the set.

The auto effluent accessory fits over the auto effluent pump and pinch valves. The auto effluent accessory alternately fills and empties the auto effluent bags to a drain, eliminating the need for manual draining or effluent bag changes during therapy.

## Low-flow and high-flow sets

Disposable sets are classified as low-flow or high-flow according to the size of tubing used for the blood pump and blood transport:

- Low-flow sets offer the benefits of low extracorporeal blood volume with limited blood-flow ranges and ultrafiltration capacities.
- High-flow sets allow a wide range of blood-flow and ultrafiltration rates.

## Minimum patient weight

The minimum patient weight specification is a combination of the following factors:

- Software alarm limits, 8 kg for low-flow sets and 30 kg for high-flow sets, that allow for safe treatment with respect to fluid imbalance issues.
- The weight limitation for the specific set in use that is based on the extracorporeal blood volume.

See "Disposable set specifications", page 321 for specific disposable set specifications.

Local regulations may restrict the availability of some sets. Contact your local Baxter representative for complete ordering information.

## Disposable set description

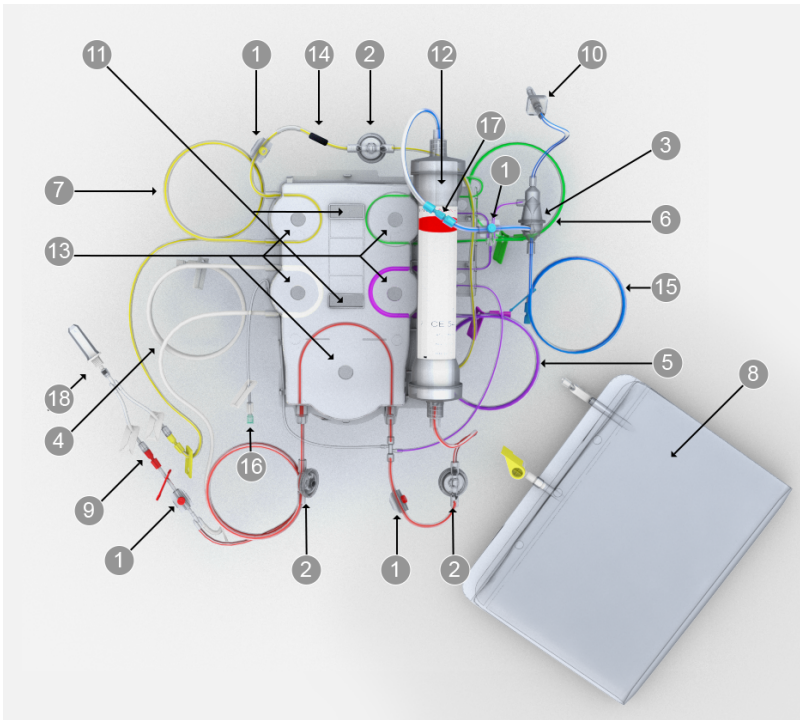

Figure CRRT disposable set components

1. **Sample sites** Color-coded ports with plug that allow needle entry to the set. Used to obtain fluid or blood samples. Accommodates a 21-gauge, or smaller diameter, needle attached to a syringe.
2. **Pressure pods** Each set includes three circular pods: access, filter and effluent. Each pod housing contains a diaphragm and fits into a pressure sensor housing on the control unit. The pods and pressure sensors enable non-invasive pressure monitoring.
3. **Deaeration chamber** On the return line, allows the system to manage air, and adds post-filter replacement solution to the return line.
4. **PBP line (white-striped)** If used, carries prescribed infusion solution from the bag on the PBP scale to the blood access line. The PBP solution enters the access line at a location immediately after patient blood enters and before the blood pump.

- 5. Replacement line (purple-striped)** Carries replacement solution from the bag on the replacement scale to the blood-flow path. Not used in all therapies.
- 7. Effluent line (yellow-striped)** Carries ultrafiltrate and waste dialysate from the fluid compartment of the filter to the effluent bag on the effluent scale.
- 9. Access line (red-striped)** Carries blood from the blood access to the filter.
- 11. Cartridge** The plastic portion of the disposable set that includes the tubing segments for the pumps and pinch valves. The cartridge covers the fluid and blood pumps when installed, and cartridge slots allow automatic set loading/unloading.
- 13. Pump segments** The lengths of tubing that thread into the raceway of each pump: blood, PBP, dialysate, replacement, and effluent. Pump segments are loaded automatically when the cartridge is installed to the loader on the front panel.
- 6. Dialysate/replacement 2 line (green-striped)** Carries solution from the green scale to the fluid compartment of the filter (dialysate) or to blood flow path (replacement 2). Included in CRRT sets only.
- 8. Effluent bag** Collects fluid from the effluent line.
- 10. Chamber monitor line** Connects the deaeration chamber to the return pressure port, enabling pressure monitoring and removal of air, if needed. The chamber monitor line removes air semi-automatically by drawing it out through the return pressure port while the liquid level sensor helps maintain the correct fluid level in the chamber. A fluid barrier at the distal end of the line protects the return pressure port from accidental blood/fluid contamination.
- 12. Filter** Filter characteristics vary according to the disposable set. See therapy descriptions for specific filter information.
- 14. Electrostatic discharger ring** Discharges electrostatic voltage from the set that can cause artifacts on cardiac monitors.

**15. Return line (blue-striped)**

Carries blood from the filter to the blood return.

**16. Syringe line**

For systemic anticoagulation, the syringe line carries anticoagulant from the syringe to the blood-flow path. The syringe line includes a non-return valve to prevent blood from diffusing into the syringe line due to the peristaltic action of the blood pump. The syringe line is pre-clipped to the cartridge and should remain so.

**17. Warmer connection**

Male-female luer connectors allow connection to blood warmer.

**18. Rinsing accessory**

Y-line with bag spike and connections for priming operations.

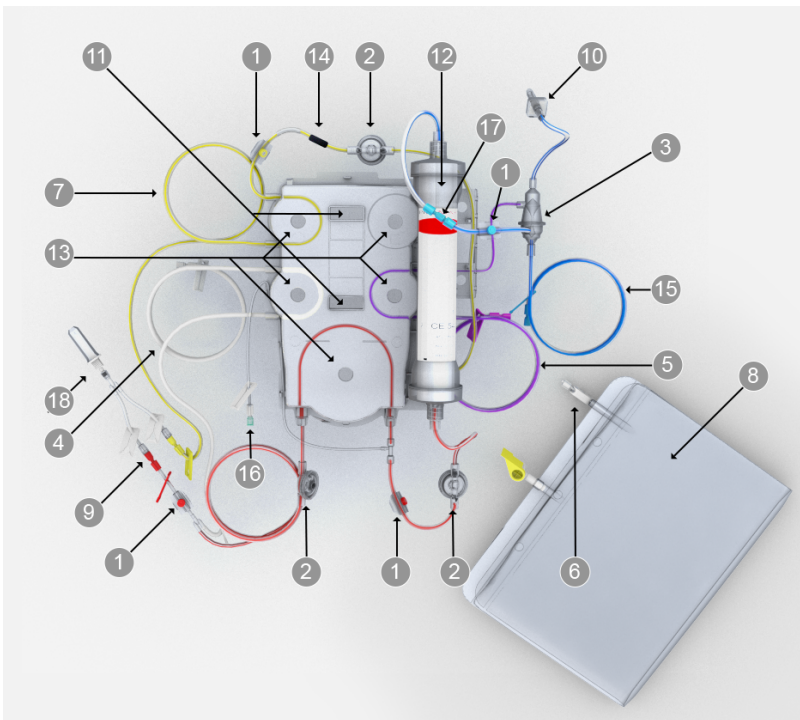

Figure TPE disposable set components

**1. Sample sites** Color-coded ports with plug that allow needle entry to the set. Used to obtain fluid or blood samples. Accommodates a 21-gauge, or smaller diameter, needle attached to a syringe.

**2. Pressure pods** Each set includes three circular pods: access, filter and effluent. Each pod housing contains a diaphragm and fits into a pressure sensor housing on the control unit. The pods and pressure sensors enable non-invasive pressure monitoring.

3. **Deaeration chamber** On the return line, allows the system to manage air, and adds post-filter replacement solution to the return line.
4. **PBP line (white-striped)** If used, carries prescribed infusion solution from the bag on the PBP scale to the blood access line. The PBP solution enters the access line at a location immediately after patient blood enters and before the blood pump.
5. **Replacement line (purple-striped)** Carries replacement solution from the bag on the replacement scale to the blood-flow path. Not used in all therapies.
6. **Effluent bag fill connector**
7. **Effluent line (yellow-striped)** Carries ultrafiltrate and waste dialysate from the fluid compartment of the filter to the effluent bag on the effluent scale.
8. **Effluent bag** Collects fluid from the effluent line.
9. **Access line (red-striped)** Carries blood from the blood access to the filter.
10. **Chamber monitor line** Connects the deaeration chamber to the return pressure port, enabling pressure monitoring and removal of air, if needed. The chamber monitor line removes air semi-automatically by drawing it out through the return pressure port while the liquid level sensor helps maintain the correct fluid level in the chamber. A fluid barrier at the distal end of the line protects the return pressure port from accidental blood/fluid contamination.
11. **Cartridge** The plastic portion of the disposable set that includes the tubing segments for the pumps and pinch valves. The cartridge covers the fluid and blood pumps when installed, and cartridge slots allow automatic set loading/unloading.
12. **Filter** Filter characteristics vary according to the disposable set. See therapy descriptions for specific filter information.
13. **Pump segments** The lengths of tubing that thread into the raceway of each pump: blood, PBP, dialysate, replacement, and effluent. Pump segments are loaded automatically when the cartridge is installed to the loader on the front panel.
14. **Electrostatic discharger ring** Discharges electrostatic voltage from the set that can cause artifacts on cardiac monitors.

15. **Return line (blue-striped)**  
Carries blood from the filter to the blood return.
16. **Syringe line** For systemic anticoagulation, the syringe line carries anticoagulant from the syringe to the blood-flow path. The syringe line includes a non-return valve to prevent blood from diffusing into the syringe line due to the peristaltic action of the blood pump. The syringe line is pre-clipped to the cartridge and should remain so.
17. **Warmer connection**  
Male-female luer connectors allow connection to blood warmer. The connectors can be used with the SP-420 extension line and the **TherMax** blood warmer disposable.
18. **Rinsing accessory** Y-line with bag spike and connections for priming operations.

## Blood warmers

### About blood warmers



#### **WARNING!**

Adjust the temperature of the blood warming device according to hospital policy. Global positive heat balance and net patient warming are possible.



#### **CAUTION!**

Post-replacement infusion solution flows into the deaeration chamber downstream of the warmer connection, and can reduce blood warmer efficiency when high rates of postdilution replacement are prescribed.



#### **CAUTION!**

Do not use a warmer on the replacement or PBP infusion lines: a warmer can generate air bubbles that can collect in the deaeration chamber or filter.



#### **CAUTION!**

Do not use a warmer on the dialysate line: a warmer can generate air bubbles that can accumulate in the filter/dialyzer dialysate compartment and impair solute transfer.

**CAUTION!**

Refer to the appropriate operator's manual for the specific blood warmer in use for more information.

**NOTE!**

Use only the blood warmers approved for use with the **PrisMax** system, and install and operate according to blood warmer instructions.

Blood warmers are designed to compensate for heat loss due to fluid exchange during treatment. The degree of patient heat loss depends on the fluid exchange rate and the temperature of the fluid bags. The **PrisMax** system accommodates several blood warmer accessories to compensate for heat loss.

## Enabling blood warmers

An authorized service technician will enable the arm-installed blood warmer in Service mode for use with the **PrisMax** system. If required by the enabled warmer model, a dedicated Connect Blood Warmer screen displays instructions for connecting the warmer to the disposable set. When a sleeve warmer is enabled, no specific setup screen is displayed.

## TherMax blood warmer

### Overview

The **TherMax** blood warmer is a high-efficiency, low extracorporeal blood volume, blood warming device. It is designed for use with the **PrisMax** system. The blood warmer is an intelligent warmer. The blood warmer is a connected warmer integrated with the patient prescription. The operator inputs a prescription temperature which the blood warmer uses to calculate how much to heat the blood so that it returns to the patient's bloodstream at that prescription temperature. Once the prescription is entered, no further management or power adjustments are needed by the operator to maintain the desired level of heating.

### Description

The blood warmer unit consists of two parts while in use, the **TherMax** device that is mounted on an arm on the side of the **PrisMax** control unit, and a disposable which is inserted into the front of the blood warmer and contacts the top and bottom heating plates. The blood warmer has a serial communication cable connected to the **PrisMax**

system. The communication cable allows the blood warmer to respond to changing treatment parameters. The operating configuration of the blood warmer is in the treatment position, cover closed and bag locked.

### Setup

Ensure that blood warmer is attached to an A/C outlet, it does not receive power from the **PrisMax** system. Ensure that the communication cable is connected to the **PrisMax** system. Turn on the **TherMax** blood warmer by pressing and holding the power button. The blood warmer must be turned on separately from **PrisMax**.

Before SETUP and priming, obtain the blood warmer disposable along with the rest of the materials for priming and treatment for the **PrisMax** system.

Follow the instructions on the **PrisMax** system's user interface to complete setup. Following the selection of the blood warmer, the operator will be prompted for the prescription temperature entry. Once the prescription has been properly set, the **PrisMax** system will guide the operator through the blood warmer connection. Realtime feedback, through the use of animation and popup screens, or both, will instruct the operator on the proper order of connection, and to mitigate any mistake or misstep that the operator may make. Once the operator has completed the connection of the **TherMax** blood warmer disposable to the **PrisMax** therapy disposable, no further operator interaction with the blood warmer itself is necessary. The **PrisMax** system will automatically test and prime the blood warmer without operator interaction.



### CAUTION!

Do not open the warmer or unlock the bag during treatment. Opening the warmer or unlocking the bag during treatment will cause an alarm requiring treatment termination.

### Treatment

Unless the physician has ordered a new temperature prescription, or if the patient's condition has changed, there is no need for the operator to manage the blood warmer or warming operation. The blood warmer reacts automatically to ambient temperature changes, prescription changes and pump stoppages. If there are any detected issues, the blood warmer will communicate these issues to the **PrisMax** system. The **PrisMax** system will then provide detailed instructions on how to mitigate any issues in order to continue treatment, or discontinue treatment and start a new treatment session.

### End of treatment

The **PrisMax** system will instruct the operator through completing a treatment session.

### Safety

The blood warmer has a number of safety features that mitigate any risks involved with heating the blood or adding a disposable into the blood path of the **PrisMax** disposable. The blood warmer can detect blood leaks in its disposable, it can detect deviations from proper operational configurations, and it has an independent hardware protection from overheating leading to hemolysis.

### Performance

The blood warmer is capable of heating under a wide range of environmental and prescription variables. However, there are certain combinations of low ambient temperature, high prescription temperature and high post replacement flow rates where the blood warmer may not be able to deliver the prescribed blood return temperature. In these conditions, a dialog window will be displayed, notifying the operator of this.

### Cleaning

The only time the blood warmer cover should be unlocked and opened is when cleaning of the thermal plates is necessary. Clean the blood warmer using the same procedures documented for cleaning the **PrisMax** system itself. Once cleaning of the blood warmer is complete, close and lock the cover of the blood warmer.

### Alarms

See the alarms chapter for **TherMax** blood warmer specific alarms. The blood warmer does modify the procedure for air in blood removal when it is in use. The **PrisMax** air removal dialog will guide the user through the process. Clamps are required to perform this process.

## PrismaTherm II blood warmer

The **PrismaTherm II** blood warmer consists of a heated aluminum cylinder and an extension line, called SP420, coiled into a groove in the cylinder. The extension line connects to the disposable set warmer connection between the filter outlet and the deaeration chamber.



#### CAUTION!

Because the **PrisMax** system cannot detect air introduced in the line downstream of the Air Bubble Detector (ABD), it is important to place the extension line upstream of the Air Bubble Detector (ABD).

**CAUTION!**

Post-replacement infusion solution flows into the deaeration chamber downstream of the warmer connection, and can reduce PrismaTherm II blood warmer efficiency when high rates of post-dilution replacement are prescribed.

**NOTE!**

The detection behaviors for return pressure alarms are modified by the presence of the warming tube.

The heating cylinder's operating temperature is user selectable. It determines the maximum temperature of the cylinder, not the blood outlet temperature.

**PrismaTherm II pressure drop**

Connecting an extension line from the **Prismatherm II** blood warmer to the set, significantly increases the volume of the extracorporeal blood circuit. This added volume requires attention during prescription, especially for patients with low body weight.

The extension line causes a pressure drop between the filter outlet and the deaeration chamber, which is approximately proportional to the blood flow rate, but also depends on the blood hemoconcentration at the filter outlet.

Using the PrismaTherm II blood warmer can affect  $\Delta P$  and TMP measurements. This can trigger alarms for high filter pressure or filter clotting at high blood-flow rates. See the **PrismaTherm II** instructions for more information on its pressure effects.

**NOTE!**

The extracorporeal blood volume is increased by the volume of the warming tube and thus the blood return volume will be increased by the volume of the warming tube.

The **PrismaTherm II** blood warmer is compatible with these sets and maximum blood flow rates:

Table PrismaTherm II blood warmer - compatible sets and maximum blood flow rates

| Disposable set | Maximum blood flow (Qbmax) | Return pressure (Preturn) |
|----------------|----------------------------|---------------------------|
| M60            | 180 ml/min                 | 80 mmHg                   |
| M100           | 300/320 ml/min             | 130 mmHg                  |

| Disposable set | Maximum blood flow (Qbmax) | Return pressure (Preturn) |
|----------------|----------------------------|---------------------------|
| M150, oXiris   | 350/370 ml/min             | 160 mmHg                  |
| HF1000         | 330/350 ml/min             | 150 mmHg                  |
| HF1400         | 350/360 ml/min             | 150 mmHg                  |
| TPE2000        | 350 ml/min                 | 150 mmHg                  |

Determined by in vitro experiments using bovine blood (Hct 32%, protein content 60g/L) and a 13F catheter. These values are determined to provide an operating filter pressure below 400 mmHg.

In the clinical setting, these flow-rate values may need to be significantly decreased in the event of high blood viscosity (high hematocrit or other causes).

## PrismaComfort, PrismaFlo II, and PrismaFlo IIS blood warmers

The **PrismaComfort**, **PrismaFlo II**, and **PrismaFlo IIS** sleeve blood warmers consist of a control unit and a silicone sleeve that fits around the return line, downstream of the return clamp. Electrical wire resistors in the sleeve warm the return line. The efficiency of sleeve blood warmers is independent of therapy configuration or whether the replacement solution is infused predilution or postdilution.



### NOTE!

The highest set point (43°C) of the **PrismaComfort**, **PrismaFlo II** and **PrismaFlo IIS** warmers must be used with care when operating the **PrisMax** system at low effluent flow rates (below 500 ml/h) with patients weights below 30 kg. Global positive heat balance and net patient warming may be present in such circumstances.

Two sizes of sleeves are available to fit the full range of the **PrisMax** system's disposable sets and return line tubing diameters. For the most efficient warming, the sleeve size must match the tubing size. For information about availability of sleeve warmers and sleeve size, contact your local Baxter representative.

## Auto Effluent (AE) accessory

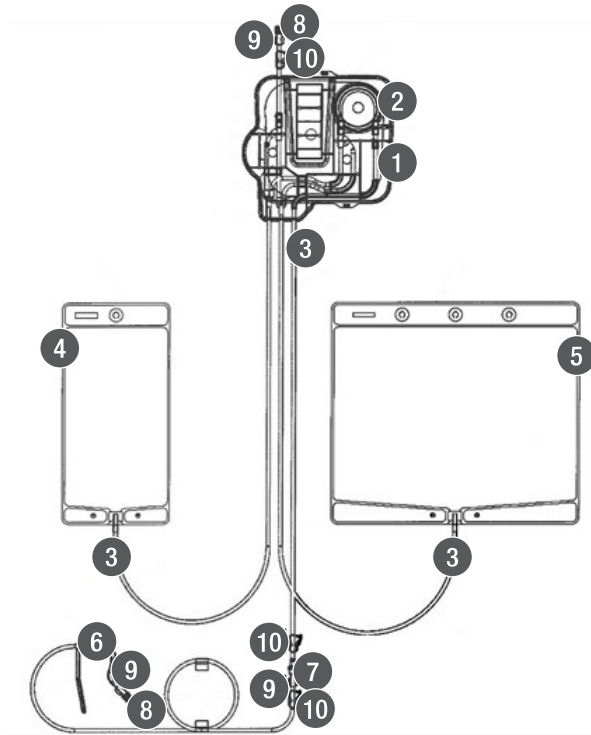

Figure Auto Effluent (AE) accessory components

1. **Cartridge** The clear plastic component that connects to the loader on the left side panel to load the pump segment and pinch valve segments of tubing.
2. **Pump segment** The semicircular tubing section that threads into the raceway of the auto-effluent pump. It is automatically loaded with the auto-effluent cartridge.
3. **Effluent line (yellow-striped)** Tubing that carries effluent to the effluent bags, and from effluent bags to the drain.
4. **1-L effluent bag** Effluent bag that mounts onto the auto-effluent scale (left side panel), and is automatically filled and drained during therapy.
5. **5-L effluent bag** Effluent bag that mounts onto the front effluent scale, and is automatically filled and drained during therapy. Also provides additional storage if the drain becomes unavailable during therapy.
6. **Drain hook** Hook mounted at the distal end of the drain line, used to attach the drain line to the drain receptacle.

7. **Check valve** One-way valve at the proximal end of the drain line to prevent effluent backflow.
8. **Vented male luer cap** Sterilization cap attached to the female luer at both ends of the auto-effluent accessory.
9. **Female luer** Fittings at the inlet and outlet of the auto-effluent accessory. The effluent line from the front disposable set attaches to the auto-effluent inlet.
10. **Pinch clamp** Used to manually occlude the auto-effluent accessory during unloading to prevent leakage.

## Other accessories

For more information about accessories, see the spare part catalog for the **PrisMax** system.

- Blood warmers: See "About blood warmers", page 275 for a list of blood warmers approved for use with the **PrisMax** system.
- **PrismaTherm II** extension line: Used with the **PrismaTherm II** blood warmer.
- **TherMax** blood warmer disposable: Used with the **TherMax** blood warmer. The Bag is designed to allow maximum heat transfer from the warmer. Has inlet and outlet connectors to connect in line with the blood filter set.
- Effluent bag: Available in 5-liter and 9-liter sizes. Bags collect ultrafiltrate or waste dialysate, depending on therapy in use. CRRT sets include 5-liter effluent bags.
- SP-394 accessory designed for connecting several replacement containers at a time during TPE therapy. See "SP-394 accessory", page 282

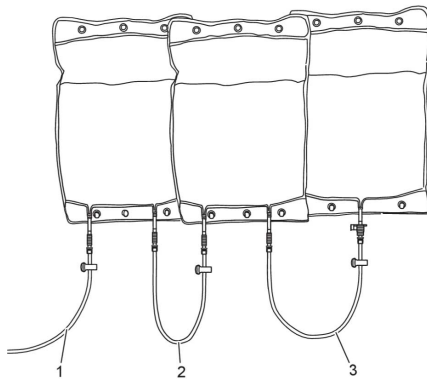

Figure SP-394 accessory

- 1. Replacement fluid line of TPE set**
- 2. Second line equipped with the non-vented spike**
- 3. First line equipped with the vented spike (blue cap)**



## Chapter 8

# Specifications

|                                      |            |
|--------------------------------------|------------|
| <b>Environmental</b>                 | <b>287</b> |
| <b>Physical</b>                      | <b>289</b> |
| <b>Hardware</b>                      | <b>290</b> |
| <b>Medical device classification</b> | <b>291</b> |
| <b>Scales</b>                        | <b>292</b> |
| <b>Power</b>                         | <b>293</b> |
| <b>Electrical safety</b>             | <b>295</b> |
| <b>External interfaces</b>           | <b>297</b> |
| <b>Compliance</b>                    | <b>299</b> |
| <b>Settings</b>                      | <b>300</b> |
| <b>Displayed data</b>                | <b>308</b> |
| <b>Syringe</b>                       | <b>312</b> |
| <b>Flow rates and accuracy</b>       | <b>313</b> |

|  |            |
|--|------------|
| <b>Alarm notification</b>  | <b>315</b> |
| <b>Access line pressure sensor</b>   | <b>317</b> |
| <b>Return line pressure sensor</b>   | <b>317</b> |
| <b>Filter pressure sensor</b>  | <b>318</b> |
| <b>Effluent line pressure sensor</b>   | <b>319</b> |
| <b>Absolute atmospheric pressure sensor</b>  | <b>320</b> |
| <b>Air Bubble Detector (ABD)</b>   | <b>320</b> |
| <b>Blood Leak Detector (BLD) - Effluent</b>  | <b>320</b> |
| <b>Disposable set specifications</b>   | <b>321</b> |
| <b>History data</b>  | <b>326</b> |
| <b>Service specifications</b>  | <b>327</b> |
| <b>Guidelines and manufacturer's declaration of electromagnetic emissions and immunity</b> | <b>329</b> |
| <b>Disposable set life</b>   | <b>337</b> |
| <b>Supported blood warmers</b>   | <b>337</b> |
| <b>Logged data</b>   | <b>338</b> |
| <b>Syringe pump accuracy</b>   | <b>338</b> |

# Specifications

## Environmental

Table Environmental specifications

|                                    |   |
|------------------------------------|---|
| Ambient operating air pressure     | 70–106 kPa  |
| Ambient operating temperature      | 16–38°C (61–100°F)  |
| Ambient operating humidity         | <p>Lower limit: 15% RH (non-condensing) at 16–38°C (61–100°F)</p> <p>Upper limit: 85% RH (non-condensing) at 16–28°C (61–82°F)</p> <p>At temperatures between 28–38°C (82–100°F), the upper limit is reduced by 2% per °C. The maximum operating humidity is 65% RH (non-condensing) at the maximum ambient temperature 38°C (100°F).</p> |
| Transport and storage temperature  | <p>-18 to +54°C (0–130°F)</p> <p>Allow unit to acclimate at ambient operating temperature for at least one hour before use.</p>   |
| Transport and storage humidity     | 10–85% RH (non-condensing at 35°C, 95°F)  |
| Transport and storage air pressure | 50–106 kPa (375–795 mmHg)   |

|  |  |
|--|--|
| Control unit interior air temperature      | Maximum 55°C (131°F) at air outflow port when the external temperature is 38°C (100°F).  |
| Maximum drain temperature                  | Auto effluent (AE) accessory: 38°C (100°F)   |
| Loudness of device during normal operation | <p>Less than 65 dB(A) over a 24-hour period, measured at a distance of 0.5 m from the device during normal operation (no alarm condition).</p> <p>Conforms to IEC 60601-1 [ed3.0] [2005-12] Medical electrical equipment - General requirements for basic safety and essential performance (section 9.6.2.1 specifications).</p> <p>Maximum alarm loudness complies with applicable standards for hazard noise levels. Alarm sounds are intermittent (not continuous).</p>   |
| Speaker loudness (main and backup)         | Capable of generating 65–75 dB(A) at one meter.  |
| Vibration/shock during transportation      | <p>The control unit can operate in Therapy mode and Service mode when exposed to:</p> <ul style="list-style-type: none"> <li>• Sinusoidal vibration according to IEC 60068-2-6 [ed7.0] [2007-12]: Environmental testing - Part 2-6: Tests - Test Fc: Vibration (sinusoidal).</li> <li>• Random vibration, wide band, general requirements according to IEC 60068-2- 64 [ed2.0] [2008]: Environmental testing - Part 2-64: Tests - Test FH: vibration, broadband random and guidance.</li> <li>• A bump according to IEC 60068-2-29 [ed2.0b] [1987]: Environmental testing - Part 2-29: Test Eb and guidance: Bump.</li> <li>• Shock according to IEC 60068-2-27 [ed4.0] [2008]: Environmental testing - Part 2-27: Tests - Test Ea and guidance: Shock.</li> </ul> |

|                                  |   |
|----------------------------------|---|
| Vibration/shock during operation | Acceleration spectral density (ASD), isotropic, 2–200 Hz<br>ASD $\leq 5 \times 10^{-8}$ g <sup>2</sup> /Hz  |
| Fluid protection                 | IPX1 (protection against vertically falling water drops) as specified in IEC 60529.   |
| Service frequency                | Control unit displays a message for periodic maintenance (PM) at the following intervals, whichever comes first: <ul style="list-style-type: none"> <li>• every 6000 hours of operation</li> <li>• after a user-selectable PM interval</li> </ul> |
| Service life                     | At least 8 years or 24,000 hours of operation, whichever is less.   |

## Physical

Table **Physical specifications**

|           |   |
|-----------|---|
| Weight    | Approximately 75–80 kg (165–176 lb) without fluid bags or disposable set, depending on installed options. |
| Height    | Approximately 140–170 cm (55–67 in.)  |
| Width     | Approximately 51 cm (20 in.)  |
| Base      | Approximately 70 × 70 cm (27.5 × 27.5 in.)  |
| Stability | The control unit complies with IEC 60601-1 [ed3.0].   |

# Hardware

Table Hardware specifications

|                 |  |
|-----------------|--|
| Microprocessors | <p>The <b>PrisMax</b> system includes several CPUs. The primary CPU (control processor, CP) runs at 600 MHz. Secondary CPUs include:</p> <ul style="list-style-type: none"> <li>• Safety processor (SP) runs at 96 MHz</li> <li>• Power system controller (PSC) runs at 24 MHz</li> <li>• Display control processor (DCP) runs at 24 MHz</li> </ul>  |
| Memory devices  | <p>The <b>PrisMax</b> system uses NAND flash memory and 512 MB of SD RAM.</p>  |
| SDHC card       | <p>32-GB capacity SDHC card for data storage in a Microsoft Windows-compatible format.</p> <p>If software determines that less than 500 MB is available on the SDHC card, the oldest patient logging data is deleted until 500 MB is available.</p> <p>Software stores system calibration data for the 50 most recent calibration updates.</p> <p>Use only Baxter-supplied SDHC cards.</p> |
| Display         | <p>Integral 1024 × 768 16-bit color LCD monitor</p>  |
| Drip tray       | <p>An alarm occurs if the drip tray detects a leak over 50 ml ±20 ml.</p>  |

# Medical device classification

Table **Medical device classifications**

|           |  |
|-----------|--|
| EU        | Class II b per Council Directive 93/42/EEC           |
| USA       | Class II per FDA 21 CFR 860                          |
| Canada    | Class III per SOR/98-282                             |
| Australia | Class II b per Therapeutic Goods Act 1989, Bill 2002 |

# Scales

Table Scales specifications

|   |  |
|---|--|
| <p>Weight range (includes bar tray and carrying bars)</p> | <p>Dialysate, replacement, PBP, effluent, auto effluent (AE):<br/>Range 0–11 kg</p> <p>Accuracy:</p> <ul style="list-style-type: none"> <li>• 0–5200 g: <math>\pm 7.0</math> g</li> <li>• 5200–11000 g: <math>\pm 14.0</math> g</li> </ul> <p>Assumes scale operation within <math>\pm 10^{\circ}\text{C}</math> (<math>\pm 50^{\circ}\text{F}</math>) of calibration temperature.</p> |
| <p>Maximum allowable bag configuration</p>                | <p>Dialysate: 5-L solution bag</p> <p>Replacement: 5-L maximum for replacement solution bag</p> <p>PBP: 5-L solution bag</p> <p>Effluent: 5-L or 9-L effluent bag</p> <p>Auto effluent (AE): 1-L bag</p>   |
| <p>Bag size compatibility</p>                             | <p>Dialysate, replacement, PBP: if bag hook spacing is compatible, can accommodate bag sizes from 250 ml to 5 L.</p>   |

# Power

Table Power specifications

|   |  |
|---|--|
| Line voltage                                    | 100–240 VAC, 50/60 Hz  |
| Under- and over- voltage                        | The <b>PrisMax</b> system's electronic circuits are protected against under- and over- voltage according to IEC 60601-1-2 [2007]: Medical electrical equipment: Part 1-2: General requirements for basic safety and essential performance - Collateral standard: Electromagnetic compatibility - Requirements and tests.   |
| Power entry module fuses                        | M 6 A H 250V   |
| Power-factor and harmonic distortion correction | <p>Meets these requirements at 230–240 VAC, 50 Hz:</p> <p>IEC 61000-3-2 [1998] Electromagnetic compatibility (EMC). Part 3: Limits - Section 2: Limits - Limits for Harmonic Current Emissions (equipment input current up to and including 16 A per phase)</p> <p>IEC 61000-3-3 [1994] Electromagnetic compatibility (EMC). Part 3: Limits - Section 3: Limitation of voltage fluctuation and flicker in low voltage supply systems for equipment with rated current <math>\leq 16</math> A per phase and not subject to conditional connection</p> |

|                           |  |
|---------------------------|--|
| Power line transients     | <p>The <b>PrisMax</b> system performs to specifications during:</p> <ul style="list-style-type: none"> <li>• Line voltage dropouts: &lt;10 ms</li> <li>• Slow AC surges <math>\pm 20\%</math> nominal over 500 ms transition time</li> </ul> <p>Meet requirements of EN 60601-1 [2006] Medical electrical equipment - General requirements for basic safety and essential performance when starting from 0 V and rising to nominal, plus 10% (100 VAC, 120 VAC; 230 VAC; 240 VAC separately) over a one-minute period; this simulates emergency power restoration.</p> |
| Power cord                | <p>The <b>PrisMax</b> system is supplied with a power cord and plug that are standard for the region of use (for example, United States, Europe, or China). See the PrisMax System Service Manual for instructions on attaching or replacing the power cord.</p> <p>Length: 3.5 m (11.5 ft), including plug</p>  |
| Power interruptions       | <p>The system comes standard with a lithium battery that will power the system for at least 30 minutes without AC power.</p>   |
| Power                     | 350 VA peak  |
| Average power consumption | <p>Greater than 125 VA (CVHDF treatment). (When battery is charging) 60 VA nominal operation.</p>  |
| Battery characteristics   | <p>Nominal voltage: 24 V</p> <p>Capacity: 3700 mAh</p> <p>Lithium Ion Battery (LIB)</p>  |
| Nominal battery voltage   | <p>The battery pack supplies a nominal voltage of +24 V <math>\pm 15\%</math>.</p>   |

|                          |  |
|--------------------------|--|
| Minimum battery capacity | Battery pack capacity is at least 3.3 Ah for a minimum of 100 discharge cycles. When fully charged, the battery pack can support blood circulation for 30 minutes. |
| Battery recharge         | The system fully recharges the battery within 4 hours if AC power is present.  |

## Electrical safety

Table Electrical safety specifications

|                              |   |
|------------------------------|---|
| Classification               | Mobile, class I, applied part is Type CF, defibrillation-proof per IEC 60601-1.   |
| Operation                    | Continuous operation  |
| Protection against shock     | Class 1/internally powered  |
| Patient leakage current      | Conforms to section 8.7 of IEC 60601-1 [ed3.1] [2012] for type CF applied part.   |
| Radio frequency interference | The <b>PrisMax</b> system meets the electromagnetic compatibility (EMC) requirements as specified in the International Electrotechnical Commission's (IEC) 60601-1-2:2014 standard for emissions and immunity. There may be potential difficulties if the monitor is not kept separated from other equipment, such as hand-held transmitters, cellular phones and electrosurgical equipment that may generate strong radio frequency interference (RFI). See "Guidelines and manufacturer's declaration of electromagnetic emissions and immunity", page 329, for the recommended minimum distance. |

## Use of RFID Technology

**WARNING!**

Perform testing with the **PrisMax** System in the intended use environment when deployed in proximity to equipment that intentionally generates electromagnetic energy to ensure the **PrisMax** System remains safe and effective.

Perform testing in the intended use environment when using RFID technology. RFID providers should work with healthcare organization in assuring safe deployment and use of RFID near medical electrical equipment and systems. Refer to AIM standard 7351731 Annex L for implementing RAIN RFID systems.

Do not deploy technology that cannot be proven to work in the intended use environment with the **PrisMax** System.

The **PrisMax** system has been proven to work in the intended use environment for signals defined in IEC 60601-1-2:2014 standard for emission and immunity. Signals not specified in the standard, for example 860-960 MHz frequency at 54 V/m using DSB-ASK Modulation, may cause improper operation such as unexpected system errors and interruption in therapy, which can result in serious injury or death.

## Electromagnetic compatibility

Meets IEC 60601-1-2.

## Potential equalization

A potential equalization terminal is connected to the monitor chassis. It can be used to provide a direct connection between electrical equipment and the potential equalization bus bar of the electrical installation to eliminate potential differences. Do not use this terminal for additional protective grounding. If the use of other equipment constitutes a Medical Electrical System, see IEC 60601-1, Clause 16 for precautions.

# External interfaces

Table External interfaces

|                     |   |
|---------------------|---|
| External interfaces | <p>These external interfaces are electrically isolated to 2 kV:</p> <ul style="list-style-type: none"> <li>• USB</li> <li>• Ethernet</li> <li>• Serial ports (three ports: service, blood warmer communications, remote alarm/nurse call port 2)</li> <li>• Remote alarm (nurse call)</li> </ul>  |
| Communications      | <p>The following communications capabilities are built into the control unit to allow future expansion:</p> <ul style="list-style-type: none"> <li>• Controller area network (CAN) bus</li> <li>• Inter-integrated circuit (I2C) buses</li> <li>• Internal 3.3 and 5-V connections</li> <li>• Spare internal communications connections:<br/>1 × GPIO, 3 × USB, 1 × RS-232, 2 × I2C,<br/>1 × UART2/HCT, 1 × UART1, 1 × CAN</li> </ul> |
| USB port            | Communicates with an external USB 1.0 storage devices.  |

|               |   |
|---------------|---|
| Ethernet port | <p>Allows communication with external computers via an Ethernet connection with these characteristics:</p> <ul style="list-style-type: none"><li>• 10 Mbps minimum transfer rate</li><li>• RJ45 female connector</li><li>• Indicators: speed (green LED) and traffic activity (orange LED)</li><li>• Ability to be an IP-addressable device</li><li>• IP selectable</li><li>• Ability to run its own TCP/IP stack identifying the device address to the network</li></ul> |
| Serial ports  | <p>The control unit includes three external female 9-pin D-sub RS-232 ports (service, blood warmer communications, remote alarm/nurse call port 2). The ports are configurable from 9600 to 115200 baud. Connect to devices that conform to IEC 60950 (information technology equipment standard).</p>  |
| Remote alarm  | <p>The round remote alarm (nurse call) connector includes a relay that can activate a remote visual or audible alarm.</p> <p>Connector sustains maximum 26 VAC at 1 A. The connector relay closes when an alarm occurs. Connector relay opens in case of power failure or power down.</p> <p>Interface conforms to IEC 60601-1-8, section 6.11 (distributed alarm system).</p>  |

# Compliance

Table Compliance specifications

|   |  |
|---|--|
| IEC<br>60601-1:2005/A1:2012<br>(EN<br>60601-<br>1:2006/A1:2013)     | Medical Electrical Equipment - Part 1 General requirements for basic safety and essential performance  |
| IEC 62366 [2007] [1 Ed]<br>(EN<br>62366:2008/A1:2015)               | Medical Device Application of useability engineering to medical devices  |
| IEC 60601-1-2 [4Ed]<br>(2007-03)                                    | Medical electrical equipment - Part 1–2: General requirements for basic safety and essential performance - Collateral standard: Electromagnetic compatibility - Requirements and tests   |
| IEC 60601-2-16 [4Ed]<br>2012  | Medical electrical equipment - Part 2–16 Particular requirements for the safety of haemodialysis, haemodiafiltration and haemofiltration equipment)  |
| IEC 60601-1-8 [2Ed]<br>2006   | Medical electrical equipment - Part 1–8: General requirements for basic safety and essential performance – Collateral Standard: General requirements, tests and guidance for alarm systems in medical electrical equipment and medical electrical system |
| IEC 60529 [2.1Ed]<br>(2001-02)                                      | Degrees of protection provided by enclosures (IP Code)   |
| IEC 60601-1-6 [3Ed]<br>(2010-01) (EN<br>60601-1-<br>6:2010/A1:2015) | Medical electrical equipment - Part 1–6: General requirements for basic safety and essential performance - Collateral standard: Usability  |
| CAN/CSA C22.2 No.<br>60601-1:14                                     | Medical electrical equipment - Part 1: General requirements for basic safety and essential performance (Adopted IEC 60601-1:2005, third edition, 2005-12, including amendment 1:2012, with Canadian deviations)  |

|  |  |
|--|--|
| AAMI/ANSI<br>ES60601-1:2005/<br>(R)2012 and A1:2012,<br>C1:2009/ (R)2012 and<br>A2:2010/ (R)2012 | Medical electrical equipment - Part 1: General<br>Requirements For Basic Safety And Essential<br>Performance (IEC 60601-1:2005, Mod) |
| FCC Part 15 2008 (USA)<br>ICES-003 2004 (Canada)   | Unintentional radiated energy tests for Class B  |
| 21 CFR 801.109(d)<br>(USA)   | Prescription Devices – Labeling  |

## Settings

This section lists the user-controllable settings and the mode in which they can be changed. Each setting has a default value and a range of setting options. Most user-controllable settings can be adjusted in more than one mode.

### Selectable flow rates

Table Selectable flow rates specifications

| Flow rate             | Therapy where available     |
|-----------------------|-----------------------------|
| PBP                   | CWH, CVHD, CVHDF, SCUF, TPE |
| Blood Flow Rate (BFR) | CWH, CVHD, CVHDF, SCUF, TPE |
| PFR                   | CWH, CVHD, CVHDF, SCUF      |
| PPL                   | TPE                         |
| Dia                   | CVHD, CVHDF                 |
| Rep                   | CWH, CVHD, CVHDF, TPE       |
| Rep2                  | CWH                         |
| Syr                   | CWH, CVHD, CVHDF, SCUF, TPE |
| C++Syr                | CWH, CVHD, CVHDF, SCUF      |

## General settings

Table General settings specifications

| General setting                              | Range  | Setting location/access  |
|--|--|--|
| Display brightness<br>(System Configuration) | Screen: Slider control<br>adjusts from dimmest to<br>brightest setting.<br><br>Status light: Bright or dim | System Configuration,<br>Display<br><br>Accessible to all users.                                     |
| Sound settings                               | Alarm volume: Range:<br>10–100% (45–70 dB)<br><br>Default: 100%  | System Configuration,<br>Sound<br><br>Accessible to all users.                                       |
| Time   | Set to current hour and<br>minute and time of day.<br><br>Default: factory-set                             | System Configuration,<br>Display, Date & time<br><br>Accessible to site expert<br>or administrator.  |
| Time Format                                  | 12 Hours<br><br>24 Hours<br><br>Default: factory-set   | System Configuration,<br>display, date & time.<br><br>Accessible to site expert<br>or administrator. |
| Date   | Set to current year,<br>month, and day.<br><br>Default: factory-set  | System Configuration,<br>Display, Date & time<br><br>Accessible to site expert<br>or administrator.  |
| Date display                                 | Day/Month/Year<br><br>Month/Day/Year<br><br>Year/Month/Day<br><br>Default: Day/Month/Year                  | System Configuration,<br>Display, Date & time<br><br>Accessible to site expert<br>or administrator.  |
| Access pressure range                        | Negative or positive<br><br>Default: Negative  | Automatically set, based<br>on pressure range being<br>measured.                                     |

| General setting                   | Range   | Setting location/access  |
|-----------------------------------|---|--|
| Return pressure drop limit        | <p>Pressure can only be adjusted to a value that is lower than the default for the set.</p> <p>Increment: 1 mmHg</p> <p>Default: 50 mmHg for flow &lt; 200 ml/min, 70 mmHg for flow &gt; 200 ml/min.</p>  | <p>Other settings in the prescription or therapy screen.</p> <p>Accessible to all users.</p> |
| Gain/loss limit setting           | <p>60–400 ml/3h</p> <p>Can only be adjusted to a value that is lower than the default value based on patient weight.</p> <p>Increment: 1 ml/3h</p> <p>Default: <math>18.0 \times BW - 70.0</math></p> <p>The gain/loss limit can be further restricted by the applicable range for the selected disposable set.</p> | <p>Other settings in the prescription or therapy screen.</p> <p>Accessible to all users.</p> |
| Patient body weight               | <p>1–999.9 kg</p> <p>Increment: 0.1 kg</p>  | <p>Setup mode, Patient</p> <p>Accessible to all users.</p>                                   |
| Patient hematocrit                | <p>10–60%</p> <p>Increment: 1%</p> <p>Default: 30%</p>  | <p>Setup mode, Patient</p> <p>Accessible to all users.</p>                                   |
| Return blood flow rate (End mode) | <p>10–100 ml/min</p> <p>Increment: 10 ml/min</p> <p>Default: specific to therapy/set</p>  | <p>End mode, Blood return</p> <p>Accessible to all users.</p>                                |

| General setting  | Range  | Setting location/access   |
|--|--|---|
| Auto blood return volume   | 50–150% of disposable set volume<br>Increment: 1%<br>Accuracy: $\pm 15\%$ of setting | End mode, Blood return<br>Volume rounded to the nearest 5 ml.<br>Accessible to all users. |
| Recirculation rate (End mode recirculation only)                           | 10–150 ml/min<br>Increment: 10 ml/min<br>Default: specific to set                    | End mode, Recirculation<br>Accessible to all users.                                       |
| PFR period audible reminder  | On or off<br>Default: off  | System Configuration, Display, Operations<br>Accessible to site expert or administrator.  |
| PFR period   | 15, 30 and 60 min<br>Default: 15 min   | System Configuration, Display, Operations<br>Accessible to site expert or administrator.  |
| Dose Measurement (See Section: Displayed data, Displayed dose information) | Effluent (Eff) or Ultrafiltration (UF)<br>Default: Effluent (Eff)                    | System Configuration, Display, Operations<br>Accessible to site expert or administrator.  |
| Start of charting period   | 4, 8, 12, or 24 h<br>Default: 8 (8:00 am)  | System Configuration, Display, Operations<br>Accessible to site expert or administrator.  |

| General setting                      | Range                             | Setting location/access                     |
|--------------------------------------|-----------------------------------|---|
| Chart period                         | 1, 2, 3, 4, 6, 8, 12, or 24 hours | System Configuration, Display, Operations   |
|                                      | Default: 1 hour                   | Accessible to site expert or administrator. |
| Patient fluid removal (PFR) Catch-up | Enabled or disabled               | Change Screen, Other settings               |
|                                      | Default: enabled                  | Accessible to all users.                    |

### CRRT-specific settings

Table CRRT-specific settings specifications

| CRRT setting                   | Range  |
|--------------------------------|--|
| Gain/loss caution limit (CRRT) | M60: 60–200 ml   |
|                                | M100, M150, HF1000, HF1400, oXiris: 100–400 ml   |
|                                | Increment: 10 ml. Default: (body weight × 18 to 70 ml), rounded to the closest 10 ml. If the value exceeds the maximum for the set, the maximum allowable value is used. |
|                                | Setting location: Other settings in the Prescription or Change Screen (all users)  |
| Blood Flow Rate (BFR)          | 10–450 ml/min maximum  |
|                                | Increment: 1 ml/min  |
|                                | M60, M100, M150, HF1000, HF1400, oXiris  |
|                                | Default: specific to therapy/set   |
|                                | Setting location: Prescription or Change Screen (all users)  |

| CRRT setting           | Range   |
|------------------------|---|
| Enable blood pump ramp | <p>Enable or disable</p> <p>Default: disable</p> <p>The blood pump accelerates at a minimum of 20 ml/min/sec. A ramp for any increase of 180 ml/min or less will take 9 seconds or less. With an increase larger than 180 ml/min, the ramp step is a linear acceleration that reaches the commanded rate in 9 seconds.</p> <p>Setting location: System Configuration, Features (site expert users or administrator)</p> |
| PBP flow rate          | <p>0, 10–4000 ml/h maximum; actual range specific to therapy/set (minimum 30 ml/h increment, flow-dependent)</p> <p>Increment: 2 ml/h</p> <p>Default: 0 ml/h</p> <p>Setting location: Prescription or Change Screen (all users)</p>   |
| Replacement flow rate  | <p>0–8000 ml/h maximum; actual range specific to therapy/set</p> <p>Increment: 10 ml/h</p> <p>Default: 0 ml/h</p> <p>Setting location: Prescription or Change Screen (all users)</p>  |
| Pre/post replacement   | <p>CVH: 0–100% pre-filter using replacement PRE%</p> <p>Increment: CVH: 1%. CVHDF: Pre-filter or post-filter</p> <p>Default: 100% pre-filter (CVH), pre-filter (CVHDF)</p> <p>Setting location: Prescription or Change Screen (all users)</p>   |
| Dialysate flow rate    | <p>0–8000 ml/h maximum; actual range specific to therapy/set</p> <p>Increment: 10 ml/h</p> <p>Default: 0 ml/h</p> <p>Setting location: Prescription or Change Screen (all users)</p>  |

| CRRT setting                 | Range  |
|------------------------------|--|
| PFR rate                     | 0, 10–2000 ml/h maximum; actual range specific to therapy/set<br><br>Increment: 5 ml/h<br><br>Default: 0 ml/h<br><br>Setting location: Prescription or Change Screen (all users) |
| Allowed bag volume, effluent | 5000 or 9000 ml<br><br>Default: 5000 ml<br><br>Setting location: Setup mode, Fluids or Change Screen, change bag pop-up window (all users)                                       |

### Anticoagulation settings

Table Systemic anticoagulation method specifications

| Systemic anticoagulation setting | Range  |
|----------------------------------|--|
| Syringe size                     | 20 or 50 ml<br><br>Default: 50 ml<br><br>Setting location: only the syringe size configured in Service mode is available   |
| Syringe brand                    | 20 ml (holder 20): BD PLASTIPAK, TERUMO, Covidien / Kendall, Monoject ,B. Braun (Omnifix)<br><br>50 ml (holder 50): BD PLASTIPAK, TERUMO, Codan Luer lock, Fresenius Injectomat, Covidien / Kendall, Monoject B. Braun (Omnifix)<br><br>50 ml (holder 50B): B. Braun (Perfusor)<br><br>Default: Default is set during installation.<br><br>Setting location: System Configuration, Containers & solutions, Syringe settings (site expert users or administrator) |

| Systemic anticoagulation setting                             | Range  |
|--|--|
| Syringe delivery method                                      | Continuous or bolus<br>Default: continuous<br>Setting location: Prescription or Change Screen (all users)  |
| Syringe continuous delivery rate                             | 20-ml: 0, 0.5–5.0 ml/h<br>50-ml: 0, 0.5–20.0 ml/h<br>Increment: 0.1 ml/h<br>Default: 0 ml/h<br>Setting location: Prescription or Change Screen (all users)       |
| Syringe immediate bolus delivery volume                      | 20-ml: 0, 0.5–5.0 ml<br>50-ml: 0, 0.5–9.9 ml<br>Increment: 0.1 ml<br>Default: 0 ml<br>Setting location: Change Screen, immediate bolus pop-up window (all users) |
| Syringe immediate bolus volume (End mode recirculation only) | 0, 0.5–5.0 ml<br>Increment: 0.1 ml<br>Default: 0 ml (no delivery)<br>Setting location: Change Screen, immediate bolus pop-up window (all users)                  |

### **Anticoagulation solution concentrations**

Solution concentrations are determined by the therapy and solution in use.

Table Anticoagulation solution concentrations specifications

| Solution                        | Min (mmol/L) | Max (mmol/L) | Increment (mmol/L) | Default (mmol/L) |
|---------------------------------|--------------|--------------|--------------------|------------------|
| Calcium in replacement solution | 0            | 1.75         | 0.05               | 0.0              |

## Displayed data

This section summarizes the treatment parameters and dose information displayed during treatment.

### Displayed treatment parameters

The displayed treatment parameters are determined by the therapy and anticoagulation.

Table Displayed treatment parameters specifications

| Parameter             | Description  | Applicable therapies           |
|-----------------------|--|--------------------------------|
| Patient ID            | Up to 40 characters, scanned or manually entered.                            | SCUF, CVVH, CVVHD, CVVHDF, TPE |
| Secondary ID          | Up to 40 characters, scanned or manually entered.                            | SCUF, CVVH, CVVHD, CVVHDF, TPE |
| Weight                | Patient body weight (kg)   | SCUF, CVVH, CVVHD, CVVHDF, TPE |
| Hematocrit            | Patient hematocrit (%)   | SCUF, CVVH, CVVHD, CVVHDF, TPE |
| <b>Fluid status</b>   |  |                                |
| Gain/loss limit vol   | Maximum allowable fluid balance inaccuracy before the treatment halted (ml). | SCUF, CVVH, CVVHD, CVVHDF      |
| Current gain/loss vol | Current fluid imbalance (ml)   | SCUF, CVVH, CVVHD, CVVHDF      |

| Parameter                 | Description  | Applicable therapies         |
|---------------------------|--|------------------------------|
| Current makeup vol        | Current PFR volume to be removed (ml). This volume is accumulated due to fluid pump stoppages.   | SCUF, CWH, CWHHD, CWHDF      |
| <b>Anticoagulation</b>    |  |                              |
| Syringe brand             | Brand of the syringe in use  | SCUF, CWH, CWHHD, CWHDF, TPE |
| Syringe flow rate         | Current syringe flow rate (ml/h)   | SCUF, CWH, CWHHD, CWHDF, TPE |
| Rep solution              | Name of replacement solution   | CWH, CWHDF                   |
| Rep calcium concentration | Concentration of calcium in replacement solution (mmol/L)  | CWH, CWHDF                   |
| <b>Treatment</b>          |  |                              |
| Dose                      | --   | SCUF, CWH, CWHHD, CWHDF      |
| Dose (Eff or UF)          | Eff: Effluent flow rate normalized to patient body weight (ml/kg/h).<br><br>UF: Fluid contributed by PBP, replacement, and PFR rates if delivered post-dilution and normalized to patient body weight (ml/kg/h). | SCUF, CWH, CWHHD, CWHDF      |
| <b>Disposables</b>        |  |                              |
| Set                       | Set name   | SCUF, CWH, CWHHD, CWHDF, TPE |

| Parameter                       | Description                                    | Applicable therapies   |
|---------------------------------|--|--|
| Auto effluent (AE) accessory    | Accessory name                                 | SCUF, CVWH, CWHD, CVHDF (only if auto effluent (AE) is in use) |
| Auto effluent (AE) time         | Time auto effluent (AE) in use (hours:minutes) | SCUF, CVWH, CWHD, CVHDF (only if auto effluent (AE) is in use) |
| Set time                        | Time disposable set in use (hours:minutes)     | SCUF, CVWH, CWHD, CVHDF, TPE                                   |
| Treatment time                  | Therapy time for set in use (hours:minutes)    | SCUF, CVWH, CWHD, CVHDF, TPE                                   |
| Blood warmer                    | Name of blood warmer                           | SCUF, CVWH, CWHD, CVHDF (only if blood warmer is in use), TPE  |
| Effluent bag size               | Size of effluent bag in use (ml)               | SCUF, CVWH, CWHD, CVHDF, TPE                                   |
| <b>Flow rates</b>               |  |  |
| PBP                             | Pre-blood pump flow rate (ml/h)                | SCUF, CVWH, CWHD, CVHDF, TPE                                   |
| Blood                           | Blood flow rate (ml/min)                       | SCUF, CVWH, CWHD, CVHDF, TPE                                   |
| Dialysis (Dia)                  | Dialysate flow rate (ml/h)                     | CWHD, CVHDF  |
| Replacement (Rep) (pre or post) | Replacement flow rate (ml/h)                   | CVWH, CVHDF, TPE   |
| Replacement 2 (Rep 2)           | Replacement 2 flow rate (ml/h)                 | CVWH   |
| Patient Fluid Removal (PFR)     | Patient fluid removal rate (ml/ h)             | SCUF, CVWH, CWHD, CVHDF  |

| Parameter                  | Description   | Applicable therapies         |
|----------------------------|---|------------------------------|
| Syringe                    | Syringe flow rate (ml/h)  | SCUF, CVWH, CWHD, CWHDF, TPE |
| Effluent (Eff)             | Effluent flow rate (ml/h)   | SCUF, CVWH, CWHD, CWHDF, TPE |
| Total replacement          | Total post replacement flow rate (ml/h). Includes Rep + Rep2.                               | CVWH                         |
| Pre%                       | Percentage of replacement solution infused in predilution                                   | CVWH                         |
| <b>Pressure</b>            |   |                              |
| Return pressure drop limit | The decrease in pressure below the operating point that causes a disconnection alarm (mmHg) | SCUF, CVWH, CWHD, CWHDF, TPE |
| <b>Settings analysis</b>   |   |                              |
| Total predilution          | --  | SCUF, CVWH, CWHD, CWHDF, TPE |
| Post filter hematocrit     | --  | SCUF, CVWH, CWHD, CWHDF, TPE |
| Filtration fraction blood  | --  | SCUF, CVWH, CWHD, CWHDF, TPE |
| Filtration fraction plasma | --  | SCUF, CVWH, CWHD, CWHDF      |

### Displayed dose information

The displayed dose or fluid status information is determined by the therapy and anticoagulation.

Table **Displayed dose information specifications**

| Therapy type | Dose/fluid status information                                  |
|--------------|--|
| CRRT         | CRRT dose (Eff) / CRRT dose (UF)<br><br>Prescribed / Delivered |

## Syringe

Table **General syringe specifications**

|                                     |   |
|-------------------------------------|---|
| Syringe accuracy testing            | Meets requirements of IEC 60601-2-24, 50.102. Not certified to IEC60601-2-24.   |
| Syringe fitting and anti-siphoning  | Meets requirements of IEC 60601-2-24, 54.101. Not certified to IEC60601-2-24.   |
| Overload fault threshold            | Syringe size  |
| Syringe pump stop protective system | The system control processor (CP) and safety processor (SP) continuously verify that the independent syringe pump encoder indicates no syringe pump motor rotation when commanded to stop. The system commands the syringe pump motor to stop when there is no syringe infusion, no bolus selected, or the blood pump is stopped. |

Overload thresholds:

- The overload force fault threshold is based on the selected syringe size, and is intended to detect high pressure conditions that could cause tubing rupture.
- The overload slope fault threshold is intended to detect a line occlusion to ensure safe operation.

# Flow rates and accuracy

Table **Blood flow rate specifications (specific range depends on selected therapy/set)**

|                         |  |
|-------------------------|--|
| Range                   | 10–450 ml/min  |
| Increment               | 1 ml/min   |
| Accuracy                | $\pm 10\%$ of user-set rate (at 37°C, nominal blood flow of 450 mL/min or the highest achievable disposable blood flow, access pressure of -200 mmHg, and no PBP flow) |
| Return blood flow rate  | When blood return procedure is in use: 6–100 ml/min<br><br>The range is determined by the set.   |
| Recirculation flow rate | 10–150 ml/min  |

Table **Replacement solution/fluid flow rate (specific range depends on selected therapy/set)**

|             |  |
|-------------|--|
| CVWH, CVHDF | Range: 0–8000 ml/h<br><br>Increment: 10 ml/h<br><br>Accuracy: $\pm 3\%$ for flow rates above 330 ml/h, and less than $\pm 10$ ml/h for flow rates below or equal to 330 ml/h |
| CVH         | Predilution %: 0–100%<br><br>Increment: 1%   |
| CVHDF       | Predilution %: 0% (postdilution) or 100% (predilution).  |
| TPE         | Range: 0–5000 ml/h<br><br>Increment: 10 ml/h<br><br>Accuracy: $\pm 3\%$ for flow rates above 330 ml/h, and less than $\pm 10$ ml/h for flow rates below or equal to 330 ml/h |

Table PBP solution flow rate (specific range depends on selected therapy/set)

|                     |  |
|---------------------|--|
| CVWH, CVWHD, CVWHDF | <p>Range: 0–4000 ml/h</p> <p>Increment: 2 ml/h</p> <p>Accuracy: <math>\pm 3\%</math> for flow rates above 330 ml/h, and less than <math>\pm 10</math> ml/h for flow rates below or equal to 330 ml/h</p> |
| SCUF                | <p>Range: 0–2000 ml/h</p> <p>Increment: 2 ml/h</p> <p>Accuracy: <math>\pm 3\%</math> for flow rates above 330 ml/h, and less than <math>\pm 10</math> ml/h for flow rates below or equal to 330 ml/h</p> |
| TPE                 | <p>Range: 0-1000 ml/h</p> <p>Increment: 2 ml/h</p> <p>Accuracy: <math>\pm 3\%</math> for flow rates above 330 ml/h, and less than <math>\pm 10</math> ml/h for flow rates below or equal to 330 ml/h</p> |

Table Dialysate solution/fluid flow rate (specific range depends on selected therapy/set)

|              |   |
|--------------|---|
| CVWH, CVWHDF | <p>Range: 0–8000 ml/h</p> <p>Increment: 10 ml/h</p> <p>Accuracy: <math>\pm 3\%</math> for flow rates above 330 ml/h, and less than <math>\pm 10</math> ml/h for flow rates below or equal to 330 ml/h</p> |
|--------------|---|

Table PFR performance (specific range depends on selected therapy/set)

|                 |  |
|-----------------|--|
| PFR performance | <p>Range: 0–2000 ml/h maximum (CRRT). No incorrect weight change alarms.</p> <p>Increment: 5 ml/h</p> <p>Accuracy: <math>\pm 30</math> ml/h, <math>\pm 70</math> ml/3h, <math>\pm 300</math> ml/24h</p> <p>Scales calibrated at ambient temperature for use.</p> |
|-----------------|--|

Table PPL performance (specific range depends on selected therapy/set)



|                 |   |
|-----------------|---|
| PPL performance | <p>Range: 0–1000 ml/h maximum (TPE). No incorrect weight change alarms.</p> <p>Increment: 5 ml/h</p> <p>Accuracy: <math>\pm 30</math> ml/h, <math>\pm 70</math> ml/3h, <math>\pm 300</math> ml/24h</p> <p>Scales calibrated at ambient temperature for use.</p> |
|-----------------|---|

Table Effluent flow rate (specific range depends on selected therapy/set)

|               |                      |
|---------------|----------------------|
| Effluent flow | Range: 0–10,000 ml/h |
|---------------|----------------------|

## Alarm notification

Table Alarm Notification

|  |  |
|--|--|
| Audible alarm volume   | <p>Low, moderate, high</p> <p>Meets requirements of IEC 60601-2-16, IEC 60601-8.</p>   |
| <p>Alarm silence</p>            | <p>Can be muted for 2 minutes, after which audible resumes if alarm condition is not corrected.</p> <p>Power loss alarm sounds for at least 1 minute and cannot be muted.</p>  |
| <p>Alarm silence indicator</p>  | <p>Indicates that the 120-second alarm silence is active. A countdown next to the symbol shows the silence time remaining.</p> <p>Visual alarm indicators are still active.</p> <p>The alarm silence is cancelled if a new alarm occurs.</p> <p>The alarm silence is cleared if the alarm condition is corrected.</p> <p>Pressing the <b>Alarm Silence</b> button restarts the two-minute silence interval.</p> <p>If the triggering condition that triggered the alarm still exists, the audible alarm resumes.</p> |

|  |  |
|--|--|
| Alarm priorities   | <p>High: flashing red status light</p> <p>Medium: flashing yellow status light</p> <p>Low: non-flashing yellow status light</p> <p>Information (no alarm): non-flashing green status light</p> |
| <p>Alarm Off</p>  | Indicates alarms that have been turned off.  |

IEC 60601-1-8 defines alarm priorities as follows:

Table Alarm priorities

| Potential result of failure to respond to cause of alarm condition | Onset of potential harm <sup>a</sup> |                     |                                 |
|--|--------------------------------------|---------------------|---------------------------------|
|  | Immediate <sup>b</sup>               | Prompt <sup>c</sup> | Delayed <sup>d</sup>            |
| Death or reversible injury   | High priority <sup>e</sup>           | High priority       | Medium priority                 |
| Reversible injury  | High priority                        | Medium priority     | Low priority                    |
| Minor injury or discomfort   | Medium priority                      | Low priority        | Low priority or no alarm signal |

An information signal may also be used to indicate the potential for delayed minor injury or discomfort.

- a Onset of potential harm refers to when an injury occurs and not when it is manifested.
- b Having the potential for the event to develop within a period of time not usually sufficient for manual corrective action.
- c Having the potential for the event to develop within a period of time usually sufficient for manual corrective action.
- d Having the potential for the event to develop within an unspecified time greater than that given under “prompt.”
- e Where practicable, ME EQUIPMENT with a therapeutic function incorporates automatic safety mechanisms to prevent immediate death or irreversible injury caused by the ME EQUIPMENT. See also appropriate particular standards.

## Access line pressure sensor

Table Access line pressure sensor specifications

|                                    |   |
|------------------------------------|---|
| Operating range and accuracy       | -250 to +450 mmHg<br>Accuracy: $\pm 15$ mmHg            |
| Low access pressure warning limit  | Pressure in access pod is more negative than -250 mmHg. |
| High access pressure warning limit | Pressure in access pod is greater than +300 mmHg.       |

## Return line pressure sensor

Table Return line pressure sensor specifications

|                                    |  |
|------------------------------------|--|
| Operating range and accuracy       | -50 to +350 mmHg<br>Accuracy: $\pm 5$ mmHg                       |
| High return pressure warning limit | Pressure in return deaeration chamber is greater than +350 mmHg. |

|                                  |  |
|----------------------------------|--|
| Return disconnect pressure drop  | <p>If the blood flow is less than or equal to 200 ml/min, the default pressure drop is 50 mmHg below operating point.</p> <p>If blood flow is greater than 200 ml/min, the default pressure drop is 70 mmHg below operating point.</p> <p>The pressure drop limit can be adjusted below these values to a minimum of 5 mmHg.</p> |
| Return disconnect warning limit  | Pressure in the return deaeration chamber is lower than +10 mmHg and the established operating point is higher than +10 mmHg.  |
| Fluid barrier wetting prevention | The design of the deaeration chamber, monitor line, and return sensor assembly prevents fluid barrier wetting when return pressure increases to 500 mmHg above the nominal initial level.  |

## Filter pressure sensor

Table Filter pressure sensor specifications

|                                    |   |
|------------------------------------|---|
| Operating range and accuracy       | <p>-50 to +450 mmHg</p> <p>Accuracy: <math>\pm 15</math> mmHg</p>   |
| Set disconnect warning limit       | Pressure in filter pod (immediately before the filter) is less than +10 mmHg.   |
| High filter pressure warning limit | Pressure in filter pod (immediately before the filter) is greater than 450 mmHg.  |
| Filter clotting advisory limit     | <p>One or both limits are reached (CRRT):</p> <p>Filter pressure drop is +100 mmHg greater than initial filter pressure drop.</p> <p>Filter TMP is +100 mmHg greater than initial filter TMP.</p> |
| Filter clotted warning limit       | Filter pressure drop is greater than the limit value fixed for the filter in use, or both the filter advisory and high TMP caution limits are reached (CRRT).                                     |

|                         |  |
|-------------------------|--|
| High TMP advisory limit | TMP > +350 mmHg                                      |
| High TMP caution limit  | TMP > limit value fixed for the filter in use (CRRT) |

TMP and pressure drop parameters are based on the disposable set in use.

Table **TMP and pressure drop parameters**

| Set  | TMP max (mmHg) | dPb max (mmHg) | TMP lim (mmHg) | TMP_change_max (mmHg) | dPb_change_max (mmHg) |
|--|----------------|----------------|----------------|-----------------------|-----------------------|
| M60  | 450            | 250            | 300            | 100                   | 100                   |
| M100* <sup>1</sup>   | 450            | 300            | 300            | 100                   | 100                   |
| MX150, oXiris* <sup>1</sup>  | 450            | 300            | 300            | 100                   | 100                   |
| HF1000, HF1400* <sup>1</sup>   | 500            | 300            | 300            | 100                   | 100                   |
| TPE2000  | Eq.2           | 200            | 100            | N/A                   | 60                    |
| 1: N/A   |                |                |                |                       |                       |
| 2: Rounded to nearest increment value.   |                |                |                |                       |                       |
| Eq.2 - TPE2000: $TMPa_{max} = -4.50 \times 10^{-4} \times Qb^2 + 0.645 \times Qb + 60.0$ |                |                |                |                       |                       |
| Where TMPa_max in mmHg and Qb in mL/min (see ref.2)                                      |                |                |                |                       |                       |

## Effluent line pressure sensor

Table **Effluent line pressure sensor specifications**

|                 |                   |
|-----------------|-------------------|
| Operating range | -350 to +400 mmHg |
| Accuracy        | ±15 mmHg          |

## Absolute atmospheric pressure sensor

Table Absolute atmospheric pressure sensor specifications

|                 |                           |
|-----------------|---------------------------|
| Operating range | 525–795 mmHg (70–106 kPa) |
| Accuracy        | ±20 mmHg                  |

## Air Bubble Detector (ABD)

Table Air Bubble Detector (ABD) specifications

|                          |  |
|--------------------------|--|
| Macro air/foam detection | <p>The warning alarm goes off if the transducer senses air in the return line. This happens when the transducer senses a single bubble or foam of approximately 20 <math>\mu\text{l}</math>, at blood flows of 0 to 450 ml/min within 5 ms of the bubble passing the sensor.</p> <p>Foam sensitivity tested using bovine blood: Air was injected into the pre-filter blood line at a rate of 1 ml/min, creating foam in the post-filter blood.</p> |
|--------------------------|--|

## Blood Leak Detector (BLD) - Effluent

Table Blood Leak Detector (BLD) - Effluent - Specifications

|                              |   |
|------------------------------|---|
| Minimum blood leak detection | <p>Warning alarm goes off within 20 seconds of detection.</p> <p>Leak &gt;0.35 ml/min at 25% Hct, for effluent flow rate below 5500 ml/h.</p> <p>Leak &gt;0.5 ml/min at 32% Hct, at highest effluent flow rate.</p> |
|------------------------------|---|

# Disposable set specifications

The **PrisMax** system allows a minimum blood flow range of 10 ml per minute during treatment for all sets and therapies. The low blood flow range limit is the minimum blood flow rate recommended for each set.

Maximum allowed flow rate values are the absolute maximum settings for each flow. Some therapies (for example, pre- or post-replacement infusion, SCUF) lower the available maximum flow rate.

## Minimum patient weight

Alarm limits set the minimum patient body weight allowed for a safe treatment with respect to fluid imbalance issues:

- 8 kg for low-flow sets
- 20 kg for high-flow sets

The disposable sets also have weight limitations in relation to extracorporeal blood volume. The combination of these two independent limitations results in the minimum patient weight specifications in "Minimum patient weight specifications", page 321.

Table **Minimum patient weight specifications**

| Disposable set | Minimum patient weight | Set limits |
|----------------|------------------------|------------|
| M60            | 11 kg                  | 11 kg      |
| M100           | 30 kg                  | 30 kg      |
| M150           | 30 kg                  | 30 kg      |
| HF1000         | 30 kg                  | 30 kg      |
| HF1400         | 30 kg                  | 30 kg      |
| oXiris         | 30 kg                  | 30 kg      |
| TPE2000        | Adults                 | N/A        |

Some sets are not available in some countries due to local regulations. Check with your Baxter representative for availability.

### Maximum flow rates in Therapy mode

The disposable set in use determines the maximum flow during Therapy mode.

Table Maximum flow rates in Therapy mode (part 1)

| Set  | Maximum $Q_{pfr}$<br>(ml/h) | Maximum $Q_{exch}$<br>(ml/h) | Maximum $Q_{conv}$<br>(ml/h) |
|--|-----------------------------|------------------------------|------------------------------|
| M60  | 2000                        | 8000                         | 8000                         |
| M100   | 2000                        | 8000                         | 8000                         |
| M150   | 2000                        | 8000                         | 8000                         |
| HF1000   | 2000                        | 8000                         | 8000                         |
| HF1400   | 2000                        | 8000                         | 8000                         |
| oXiris   | 2000                        | 8000                         | 8000                         |
| TPE2000  | 1000                        | N/A                          | N/A                          |
| $Q_{pfr}$ = Patient fluid removal rate<br>$Q_{exch}$ = Exchange flow rate<br>$Q_{conv}$ = Convective flow rate |                             |                              |                              |

Table Maximum flow rates in Therapy mode (continued)

| Set  | $Q_b$ (ml/min) |     | $Q_{pbp}$ (ml/h) |      | $Q_{dial}$<br>(ml/h) | $Q_{rep}$ (ml/h) |             |
|------|----------------|-----|------------------|------|----------------------|------------------|-------------|
|      | Min            | Max | SCUF<br>max      | Max  | Max                  | Max<br>pre       | Max<br>post |
| M60  | 50             | 180 | 2000             | 2000 | 4000                 | 4000             | 3000        |
| M100 | 80             | 400 | 2000             | 4000 | 8000                 | 8000             | 6000        |
| M150 | 100            | 450 | 2000             | 4000 | 8000                 | 8000             | 8000        |

| Set     | $Q_b$ (ml/min) |      | $Q_{p_{bp}}$ (ml/h) |      | $Q_{dial}$<br>(ml/h) | $Q_{rep}$ (ml/h) |             |
|---------|----------------|------|---------------------|------|----------------------|------------------|-------------|
|         | Min            | Max  | SCUF<br>max         | Max  | Max                  | Max<br>pre       | Max<br>post |
| HF1000  | 80             | 400  | 2000                | 4000 | 8000                 | 8000             | 8000        |
| HF1400  | 100            | 450  | 2000                | 4000 | 8000                 | 8000             | 8000        |
| oXiris  | 100            | 450  | 2000                | 4000 | 8000                 | 8000             | 8000        |
| TPE2000 | 100            | 250/ | N/A                 | 1000 | N/A                  | N/A              | 5000        |

$Q_b$  = blood flow rate  
 $Q_{p_{bp}}$  = PBP flow rate  
 $Q_{dial}$  = dialysis flow rate  
 $Q_{rep}$  = replacement flow rate

### Blood flow in End mode

When blood return is selected, the screen displays the returned blood fluid volume. The disposable set in use determines the rate of blood return flow ( $Q_b$ ).

Table Blood flow in End mode

| Set    | $Q_{b\_min}$ (ml/min) | $Q_{b\_max}$ (ml/min) | $Q_{b\_default}$<br>(ml/min) |
|--------|-----------------------|-----------------------|------------------------------|
| M60    | 10                    | 100                   | 40                           |
| M100   | 10                    | 100                   | 70                           |
| M150   | 10                    | 100                   | 70                           |
| HF1000 | 10                    | 100                   | 70                           |
| HF1400 | 10                    | 100                   | 70                           |

| Set     | $Q_{b\_min}$ (ml/min) | $Q_{b\_max}$ (ml/min) | $Q_{b\_default}$ (ml/min) |
|---------|-----------------------|-----------------------|---------------------------|
| oXiris  | 10                    | 100                   | 70                        |
| TPE2000 | 10                    | 100                   | 70                        |

### Blood/saline flow in recirculation

The blood/saline recirculation flow is determined by the disposable set in use. Maximum recirculation time is 60 minutes for blood recirculation and 120 minutes for saline solution.

Table Blood/saline flow in recirculation

| Set     | $Q_{b\_min}$ (ml/min) | $Q_{b\_max}$ (ml/min) | $Q_{b\_default}$ (ml/min) |
|---------|-----------------------|-----------------------|---------------------------|
| M60     | 30                    | 100                   | 40                        |
| M100    | 50                    | 100                   | 100                       |
| M150    | 50                    | 100                   | 100                       |
| HF1000  | 50                    | 100                   | 100                       |
| HF1400  | 50                    | 100                   | 100                       |
| oXiris  | 50                    | 100                   | 100                       |
| TPE2000 | 50                    | 100                   | N/A                       |

Where:  $Q_b$  = recirculation flow through the set.

**CRRT disposable sets**

Table High-flow disposable CRRT sets

| Set    | Number of priming cycles | Total priming volume (ml) | Blood volume (ml) | Unintended fluid loss or gain limit (ml/3h) |
|--------|--------------------------|---------------------------|-------------------|---|
| M100   | 1                        | 1000                      | 155               | 100–400                                     |
| M150   | 2                        | 2000                      | 193               | 100–400                                     |
| HF1000 | 1                        | 1000                      | 162               | 100–400                                     |
| HF1400 | 2                        | 2000                      | 184               | 100–400                                     |
| oXiris | 2                        | 2000                      | 193               | 100–400                                     |

Table Low-flow disposable CRRT sets

| Set | Number of priming cycles | Total priming volume (ml) | Blood volume (ml) | Unintended fluid loss or gain limit (ml/3h) |
|-----|--------------------------|---------------------------|-------------------|---|
| M60 | 1                        | 1000                      | 97                | 60–200                                      |

Table Maximum allowed flow rates (ml/h) for low-flow CRRT disposable sets

| Set | PFR  | Effluent |
|-----|------|----------|
| M60 | 2000 | 10000    |

**TPE disposable sets**

Table High-flow disposable TPE sets

| Set     | Number of priming cycles | Total priming volume (ml) | Blood volume (ml) |
|---------|--------------------------|---------------------------|-------------------|
| TPE2000 | 3                        | 3000                      | 127               |

Table Maximum allowed flow rates (ml/h) for high-flow TPE disposable sets

| Set     | Patient plasma loss (PPL) | Max volume gain (ml) |
|---------|---------------------------|----------------------|
| TPE2000 | 1000                      | 2000                 |

## History data

The **PrisMax** system stores the history data for the following events:

- Control unit power ON or OFF
- Control unit switches to battery operation
- Patient ID entered/not entered
- Patient weight and Hct entered
- Therapy and anticoagulation method selected in Setup
- Disposable set loaded
- Set identified by barcode reader or manually entered by operator
- Solution identification manually entered
- Barcode reader failure
- Prime test passes or fails
- Alarm occurs
- Operator minimizes alarm screen from display
- Button press
- Stop button press
- Treatment starts
- Syringe installed to/removed from syringe pump
- Anticoagulation bolus dose infused from the syringe pump, including interrupted bolus delivery
- Flow rate or anticoagulation setting changed during treatment

- Deaeration chamber level adjusted automatically or manually
- Allowed volume of a bag is changed
- Normalize blood leak detector (BLD) system tool used

The software memory in the **PrisMax** system saves history data if the control unit is switched off or a total loss of power occurs during treatment. Following a total loss of power, the log data can be accessed from Service mode.

## Service specifications

Table Service specifications

|                           |   |
|---------------------------|---|
| PM interval/due date      | Factory-set, available to administrator users only.   |
| Entering the service menu | <p>The control unit enters the Service menu if either of the following occur:</p> <ul style="list-style-type: none"> <li>• The user presses and holds the Stop (red) button on the power control panel during startup</li> <li>• Correct passcode entered</li> </ul> <p>The control unit automatically re-enters the service menu due to an incomplete software download, or SST requires rebooting. In either case, the following must also be true to enter the service menu:</p> <ul style="list-style-type: none"> <li>• Less than 20 seconds since Startup mode completed</li> <li>• Pumps are not turning</li> <li>• No set is installed, or service technician confirms it has been removed</li> <li>• Correct passcode entered</li> </ul> |

| SST | Includes these tests: |                      |
|-----|-----------------------|----------------------|
|     | Display               | Driver board         |
|     | ARPS                  | Isolation board      |
|     | Barcode reader        | Liquid level sensor  |
|     | Audio                 | Air bubble detector  |
|     | Pinch valves          | Return clamp         |
|     | Pressure sensors      | Liquid leak detector |
|     | Scales                | Discharger           |
|     | Loaders               | RAM                  |
|     | Motors                | TherMax              |
|     | Power board           | Syringe pump         |
|     | Main board            | Blood leak detector  |
|     | Safety board          | Final acceptance     |
|     | Speaker               |                      |

# **Guidelines and manufacturer's declaration of electromagnetic emissions and immunity**

Table Guidance and manufacturer's declaration – Electromagnetic Emissions

| <p><b>Guidance and manufacturer's declaration – Electromagnetic Emissions</b></p> <p>The PrisMax system is intended for use in the electromagnetic environment specified below. The customer or the user of the PrisMax system should ensure that it is used in such an environment.</p> <p>Electromagnetic compliance is dependent on the use of serial port and Ethernet cables that are no longer than 3 m. If using longer cables, bundle them non-inductively to that length or less. The cables may be shielded or unshielded. The PrisMax system should not be used adjacent to other equipment. If adjacent use is necessary, observe the PrisMax system to verify normal operation in the configuration in which it will be used.</p> |                   |   |
|--|-------------------|---|
| <p> <b>WARNING!</b></p> <p>Use only cables and power cords supplied by the manufacturer to avoid increased electromagnetic emissions or reduced immunity from external electromagnetic sources.</p>   |                   |   |
| <b>Emission Test</b>   | <b>Compliance</b> | <b>Electromagnetic Environment – Guidance</b>   |
| RF emission CISPR 11 / EN 55011  | Group 1           | The <b>PrisMax</b> system uses RF energy only for its internal function. Therefore, its RF emissions are very low and are not likely to cause any interference in nearby electronic equipment.                          |
| RF emission CISPR 11 / EN 55011  | Class A           | The <b>PrisMax</b> system is suitable for use in all establishments other than domestic and those directly connected to the public low-voltage power supply network that supplies buildings used for domestic purposes. |
| Harmonic emissions IEC / EN 61000-3-2  | Class A           |   |
| Voltage fluctuations/ flicker emissions IEC / EN 61000- 3-3  | Complies          |   |

Table Guidance and manufacturer's declaration – Electromagnetic Immunity

| <p><b>Guidance and manufacturer's declaration – Electromagnetic Immunity</b><br/> <b>The PrisMax system is intended for use in the electromagnetic environment specified below. The customer or the user of the PrisMax system should ensure that it is used in such an environment.</b><br/> <b>Immunity testing used the following settings to demonstrate essential performance: CWHDF; HF set; blood 200 ml/min; 1275 ml/h each pump for all fluids except syringe pump; syringe pump set to 10 ml/h; 0 ml/min effluent. Net loss/change did not exceed 30 ml/h, or 70 ml/3hrs or 300 ml/ 24hrs, for a sliding window of those durations.</b></p> |  |  |   |
|---|--|--|---|
| <b>Immunity Test</b>  | <b>IEC 60601 Test Level</b>                                      | <b>Compliance Level</b>  | <b>Electromagnetic Environment – Guidance</b>   |
| Electrostatic discharge (ESD)<br>IEC/EN<br>61000-4-2  | ±8 kV contact<br><br>±2, ±4, ±8,<br>±15 kV air                   | ±8 kV contact<br><br>±2, ±4, ±8,<br>±15 kV air                   | Floors should be wood, concrete or ceramic tile. If floors are covered with synthetic material, the relative humidity should be at least 30%. |
| Electrical fast transient / burst<br>IEC/ EN<br>61000-4-4   | ±2 kV for power supply lines<br><br>±1 kV for input/output lines | ±2 kV for power supply lines<br><br>±1 kV for input/output lines | Mains power quality should be that of a typical commercial or hospital environment.   |
| Surge IEC/EN<br>61000-4-5   | ±1 kV differential mode<br><br>±2 kV common mode                 | ±1 kV differential mode<br><br>±2 kV common mode                 | Mains power quality should be that of a typical commercial or hospital environment.   |

**Guidance and manufacturer's declaration – Electromagnetic Immunity**

The PrisMax system is intended for use in the electromagnetic environment specified below. The customer or the user of the PrisMax system should ensure that it is used in such an environment.

Immunity testing used the following settings to demonstrate essential performance: CVVHDF; HF set; blood 200 ml/min; 1275 ml/h each pump for all fluids except syringe pump; syringe pump set to 10 ml/h; 0 ml/min effluent. Net loss/change did not exceed 30 ml/h, or 70 ml/3hrs or 300 ml/ 24hrs, for a sliding window of those durations.

| Immunity Test  | IEC 60601 Test Level  | Compliance Level  | Electromagnetic Environment – Guidance   |
|--|---|---|--|
| Voltage dips, short interruptions and voltage variations on power supply input lines<br>IEC/EN<br>61000-4-11 | <5% UT<br><br>(>95% dip in UT) for 0.5 cycles<br>40% UT (60% dip in UT) for 5 cycles<br><br>70% UT (30% dip in UT) for 25 cycles, 95% dip in UT) for 5 sec. | <5% UT<br><br>(>95% dip in UT) for 0.5 cycles<br>40% UT (60% dip in UT) for 5 cycles<br><br>70% UT (30% dip in UT) for 25 cycles, 95% dip in UT) for 5 sec. | Mains power quality should be that of a typical commercial or hospital environment. If the user of the <b>PrisMax</b> system requires continued operation during power mains interruptions, it is recommended that the <b>PrisMax</b> system is powered from an uninterruptable power supply or a battery. |
| Power frequency (50/60 Hz) magnetic field<br>IEC / EN<br>61000-4-8   | 3 A/m   | 3 A/m   | Power frequency magnetic fields should be at levels characteristic of a typical commercial or hospital environment.  |

**NOTE!**

$U_T$  is the AC mains voltage prior to application of the test level.

| <p><b>Guidance and manufacturer's declaration – Electromagnetic Immunity</b><br/> The PrisMax system is intended for use in the electromagnetic environment specified below. The customer or the user of the PrisMax system should ensure that it is used in such an environment.<br/> Immunity testing used the following settings to demonstrate essential performance: CWHDF; HF set; blood 200 ml/min; 1275 ml/h each pump for all fluids except syringe pump; syringe pump set to 10 ml/h; 0 ml/min effluent. Net loss/change did not exceed 30 ml/h, or 70 ml/3hrs or 300 ml/ 24hrs, for a sliding window of those durations.</p> |                                 |                  |   |
|---|---------------------------------|------------------|---|
| Immunity Test   | IEC 60601 Test Level            | Compliance Level | Electromagnetic Environment – Guidance  |
|   |                                 |                  | Portable and mobile RF communications equipment should be used no closer to any part of the <b>PrisMax</b> system including cables, than the recommended separation distance calculated from the equation applicable to frequency of the transmitter. |
|   |                                 |                  | <b>Recommended separation distance:</b>   |
| Conducted RF<br>IEC/EN<br>61000-4-6   | 3 Vrms<br><br>150 KHz to 80 MHz | 3 Vrms           | $d = 1.2 \sqrt{P}$ 80 MHz to 800 MHz  |

**Guidance and manufacturer's declaration – Electromagnetic Immunity**

The PrisMax system is intended for use in the electromagnetic environment specified below. The customer or the user of the PrisMax system should ensure that it is used in such an environment.

Immunity testing used the following settings to demonstrate essential performance: CVVHDF; HF set; blood 200 ml/min; 1275 ml/h each pump for all fluids except syringe pump; syringe pump set to 10 ml/h; 0 ml/min effluent. Net loss/change did not exceed 30 ml/h, or 70 ml/3hrs or 300 ml/ 24hrs, for a sliding window of those durations.

| Immunity Test                       | IEC 60601 Test Level           | Compliance Level | Electromagnetic Environment – Guidance  |
|-------------------------------------|--------------------------------|------------------|---|
| Radiated RF<br>IEC/ EN<br>61000-4-3 | 3 V/m<br><br>80 MHz to 2.5 GHz | 3 V/m            | $d = 1.2 \sqrt{P}$ 80 MHz to 800 MHz<br><br>$d = 2.3 \sqrt{P}$ 800 MHz to 2.5 GHz<br><br>where "P" is the maximum output power rating of the transmitter in volt-ampere (VA) according to the transmitter manufacturer and "d" is the recommended separation distance in meters (m).<br><br>Field strengths from fixed RF transmitters, as determined by an electromagnetic site survey <sup>1</sup> , should be less than the compliance level in each frequency range <sup>2</sup> .<br><br>Interference may occur in the vicinity of equipment marked with the following symbol: |

**Guidance and manufacturer's declaration – Electromagnetic Immunity**

The PrisMax system is intended for use in the electromagnetic environment specified below. The customer or the user of the PrisMax system should ensure that it is used in such an environment.

Immunity testing used the following settings to demonstrate essential performance: CVVHDF; HF set; blood 200 ml/min; 1275 ml/h each pump for all fluids except syringe pump; syringe pump set to 10 ml/h; 0 ml/min effluent. Net loss/change did not exceed 30 ml/h, or 70 ml/3hrs or 300 ml/ 24hrs, for a sliding window of those durations.

| Immunity Test | IEC 60601 Test Level | Compliance Level | Electromagnetic Environment – Guidance  |
|---------------|----------------------|------------------|---|
|               |                      |                  |  |

**NOTE!**

At 80 MHz and 800 MHz, the higher frequency range applies.

**NOTE!**

These guidelines may not apply in all situations. Electromagnetic propagation is affected by absorption and reflection from structures, objects and people.

<sup>1</sup> Field strengths from fixed transmitters, such as base stations for radio (cellular/cordless) telephones and land mobile radios, amateur radio, AM and FM radio broadcast and TV broadcast cannot be predicted theoretically with accuracy. To assess the electromagnetic environment due to fixed transmitters, an electromagnetic site survey should be considered. If the measured field strength in the location in which the **PrisMax** system is used exceeds the applicable RF compliance level above, the **PrisMax** system should be observed to verify normal operation. If abnormal performance is observed, additional measures may be necessary, such as reorienting or relocating the **PrisMax** system.

<sup>2</sup> Over the frequency range 150 kHz to 80 MHz, field strength should be less than 3 V/m.

Table Recommended separation distances between portable and mobile RF communications equipment and the PrisMax machine

The PrisMax system is intended for use in the electromagnetic environment in which radiated RF disturbances are controlled. The customer or the user of the PrisMax system can help prevent electromagnetic interference by maintaining a minimum distance between portable and mobile RF communications equipment (transmitters) and the PrisMax system as recommended below, according to the maximum output power of the communications equipment.

| Rated maximum output power of transmitter (VA) | Separation distances according to frequency of transmitter (m) |   |  |
|--|--|---|--|
|  | 150 KHz to 80 MHz<br>$d = 1.2 \sqrt{P}$                        | 80 KHz to 800 MHz<br>$d = 1.2 \sqrt{P}$ | 800 KHz to 2.5 GHz<br>$d = 2.3 \sqrt{P}$ |
| 0.01   | 0.12   | 0.12                                    | 0.23                                     |
| 0.1  | 0.38   | 0.38                                    | 0.73                                     |
| 1  | 1.2  | 1.2                                     | 2.3                                      |
| 10   | 3.8  | 3.8                                     | 7.3                                      |
| 100  | 12   | 12                                      | 23                                       |

For transmitters rated at maximum output power not listed above, the recommended separation distance  $d$  in meters (m) can be estimated using the equation applicable to the frequency of the transmitter, where  $P$  is the maximum output power rating of the transmitter in volt-ampere (VA) according to the transmitter manufacturer.



**NOTE!**

At 80 MHz and 800 MHz, the higher frequency range applies.



**NOTE!**

These guidelines may not apply in all situations. Electromagnetic propagation is affected by absorption and reflection from structures, objects and people.



**NOTE!**

To mitigate electromagnetic interference (EMI) concerns: only use the USB port for its intended purpose, and never connect USB wireless devices (due to the potential for causing EMI).

## Disposable set life

Disposable set life (use duration before set change) is as follows for each type of therapy:

Table Disposable set life specifications

| Therapy          | Maximum life (hours)                                | Default life (hours)                                |
|------------------|---|---|
| CRRT             | 72  | 72  |
| TPE              | 6   | 6   |
| AE accessory set | 6 days, or 560,000 revolutions, which ever is first | 6 days, or 560,000 revolutions, which ever is first |



### **WARNING!**

To assure adequate filter performance, it is recommended that the set be changed every 24 hours of use. However, the set must be changed after 3 days (72 hours). Continued use beyond this limit could result in rupture of the pump segments, with risk of patient injury and death.

## Supported blood warmers

The **PrisMax** system supports the following blood warmers for use during therapy:

- **PrismaFlo IIS**
- **PrismaTherm II**
- **PrismaComfort**
- **TherMax**

## Logged data

The **PrisMax** system can record and export the following:

- Event history per set
- Treatment data (pressure, scale, pump, event, trend, dose, and volume) at 10-second intervals
- Treatment time duration
- Patient history (sets used and CRRT dose per patient)
- Treatment history, including total treatment time (blood pump turning time), total delivery time (fluid pump turning times), and total down time (treatment time minus delivery time).

**PrisMax** is capable of logging data for 10 years of expected usage (1200 hours per year) in its storage memory. If the storage memory approaches its full capacity, the **PrisMax** will erase older log data to create storage space for new log data.”



### NOTE!

Please wait at least 10 seconds before removing the USB drive after the **PrisMax** declares the data export is complete.

## Syringe pump accuracy

Table Systemic anticoagulation syringe pump accuracy

| Syringe size |                   | 20 ml | 50 ml |
|--------------|-------------------|-------|-------|
| Large bolus  | Volume            | ≥2 ml | ≥3 ml |
|              | Allowed deviation | ±5 %  | ±5 %  |

|                                 |                   |         |         |
|---------------------------------|-------------------|---------|---------|
| <b>Small bolus</b>              | Volume            | <2 ml   | <3 ml   |
|                                 | Allowed deviation | ±15 %   | ±10 %   |
| <b>Fast continuous delivery</b> | Rate              | ≥2 ml/h | ≥3 ml/h |
|                                 | Allowed deviation | ±5 %    | ±5 %    |
| <b>Slow continuous delivery</b> | Rate              | <2 ml   | <3 ml   |
|                                 | Allowed deviation | ±15 %   | ±10 %   |

Above specifications assume:

1. Deviation is the difference between target and achieved flow rates
2. Pressure of 0 to 600 mmHg using approved syringes

The syringe pump conforms to the accuracy testing, and syringe fitting requirements in 1<sup>st</sup> edition of IEC 60601-2-24 [R12], 50.102, and 54.101, respectively, and 2<sup>nd</sup> edition of IEC 60601-2-24, 201.12.1.102 and 201.15.101, respectively.



## Chapter 9

# Glossary

Glossary (alphabetically sorted)

**343**



# Glossary

## Glossary (alphabetically sorted)

Table Glossary

|                               |   |
|-------------------------------|---|
| A                             | Amperes   |
| ABD                           | Air Bubble Detector                                     |
| AC                            | Alternating Current                                     |
| Auto Effluent (AE)            | Auto Effluent, an automatic effluent emptying accessory |
| ARPS                          | Automatic Reposition System                             |
| ASCII                         | American standard code for information interchange      |
| Authorized service technician | Appropriately trained and certified service technician  |
| A-V                           | Arterio-Venous  |
| BCR                           | Barcode Reader (scanner)                                |
| BFR                           | Blood Flow Rate   |
| BIOT                          | Built In Ongoing Tests                                  |

|                           |   |
|---------------------------|---|
| Blood Leak Detector (BLD) | Blood Leak Detector                                   |
| Button                    | Onscreen button or front panel membrane buttons       |
| C                         | Celsius   |
| CAN                       | Controller Area Network                               |
| CB                        | Certification Body                                    |
| Cb_ca                     | Concentration of calcium in blood                     |
| cc                        | Cubic centimeter                                      |
| CD                        | Compact Disc  |
| CD-ROM                    | Compact Disc-Read Only Memory                         |
| CE                        | Conformité Européenne                                 |
| CF                        | Type CF Applied Part                                  |
| CGMP                      | Current Good Manufacturing Practices                  |
| CHF                       | Congestive Heart Failure                              |
| CISPR                     | International Special Committee on Radio Interference |
| CP                        | Control Processor                                     |
| CRC                       | Cyclic Redundancy Check                               |
| CRRT                      | Continuous Renal Replacement Therapy                  |
| CSA                       | Canadian Standards Association                        |
| CUL                       | Canadian Underwriters Laboratories                    |
| CVWH                      | Continuous Veno-Venous Hemofiltration                 |

|                             |  |
|-----------------------------|--|
| CVHD                        | Continuous Veno-Venous Hemodialysis  |
| CVVHDF                      | Continuous Veno-Venous Hemodiafiltration   |
| dB(A)                       | A-weighted decibels  |
| DC                          | Direct Current   |
| DCP                         | Display Control Processor  |
| Disposable set instructions | Disposable set instructions include operating flow rates, filter pressures, priming requirements, performance data, and other information for using the set. |
| ECG                         | Electrocardiogram  |
| EDR                         | Electrostatic Discharge Ring   |
| EEPROM                      | Electrically Erasable Programmable Read Only Memory  |
| EMC                         | Electromagnetic Compatibility  |
| EMI                         | Electromagnetic Interference   |
| EN                          | European Norm  |
| EPROM                       | Electrically Programmable Read Only Memory   |
| ESD                         | Electrostatic Discharge  |
| EtO                         | Ethylene Oxide   |
| F                           | Fahrenheit   |
| Fac                         | Fraction of calcium available to filter  |
| Fac2%                       | Conversion of factor to percent  |
| FDA                         | Food and Drug Administration   |

|         |   |
|---------|---|
| FF%     | Filtration Fraction   |
| Filter  | Depending on the therapy in use, refers to the hemofilter/dialyzer. |
| Fp      | Plasma water fraction is the water fraction in whole plasma.        |
| GND     | Ground point  |
| GUI     | Graphic User Interface  |
| h       | Hour  |
| Hct     | Hematocrit  |
| Hctpost | Post-filter hematocrit  |
| HF      | High Flow   |
| HHMM    | Hour and minute   |
| hPa     | HectoPascal   |
| Hz      | Hertz (cycles per second)   |
| I2C     | Inter-integrated circuit  |
| ICU     | Intensive Care Unit   |
| IEC     | International Electro-technical Commission                          |
| IFU     | Instructions for Use  |
| ISO     | International Organization for Standards                            |
| ISTA    | International Safe Transit Association                              |
| K       | Filter clearance (flow rate)  |

|        |   |
|--------|---|
| kg     | Kilogram  |
| kPa    | KiloPascal  |
| KUF    | Ultrafiltration coefficient of a filter   |
| kV     | Kilovolt  |
| L      | Liter   |
| LCD    | Liquid Crystal Display  |
| LED    | Light Emitting Diode  |
| LF     | Low Flow  |
| LLS    | Liquid Level Sensor   |
| mA     | Milliamperes  |
| MAC    | Media Access Control  |
| Manual | Unless otherwise specified, the operator's manual for the <b>PrisMax</b> system (this manual). Provides general information and operating, maintenance, and troubleshooting instructions. |
| MDD    | Medical Devices Directive   |
| MDR    | Medical Device Reportable   |
| MEE    | Medical Electrical Equipment  |
| Mfr    | Manufacturer  |
| min    | Minute  |
| ml     | Milliliter  |
| ml/3h  | Milliliters per three hours   |

|         |   |
|---------|---|
| ml/h    | Milliliters per hour                                |
| ml/kg/h | Milliliters per kilogram per hour                   |
| mm      | Millimeters   |
| mmHg    | Millimeters of mercury                              |
| mmol    | Millimol  |
| Mmol/L  | Millimols per liter                                 |
| mOhms   | Milliohms   |
| MRI     | Magnetic Resonance Imaging                          |
| MTBF    | Mean Time Between Failures                          |
| mV      | Millivolts  |
| mW      | Milliwatt   |
| N       | Newton  |
| N/A     | Not applicable                                      |
| NiMH    | Nickel-metal hydride                                |
| NOR     | Nonvolatile memory based on NOR-gate technology     |
| NRTL/C  | Nationally Recognized testing Laboratories / Canada |
| NVM     | Nonvolatile Memory                                  |
| NVRAM   | Nonvolatile Random Access Memory                    |
| OIML    | International Organization of Legal Metrology       |

|                       |  |
|-----------------------|--|
| Onscreen instructions | Detailed operating instructions on the interactive display. Instructions include step-by-step instructions for setting up, administering, verifying settings, and ending patient treatments; alarm messages and alarm handling instructions; and help screens that provide additional information. |
| Operator              | Appropriately trained and qualified clinician. Selects settings in accordance with prescribed treatment, responds to alarms, troubleshoots the system, and manages accessories.  |
| P                     | Pressure   |
| PBP                   | Pre-Blood Pump   |
| PDMS                  | Patient Data Management System   |
| PFR                   | Patient Fluid Removal  |
| PM                    | Preventive Maintenance   |
| Pmax                  | Maximum pressure   |
| PN                    | Part number  |
| POST                  | Power On Self Test   |
| PR                    | Return pressure  |
| PSC                   | Power System Controller  |
| PV                    | Pinch Valve  |
| Q                     | Flow   |
| RAM                   | Random Access Memory   |
| RDL                   | Return Disconnect Limit  |
| RH                    | Relative Humidity  |

|        |  |
|--------|--|
| RoHS   | Restriction of Hazardous Substances                |
| ROM    | Read-Only Memory                                   |
| RPM    | Rotations Per Minute                               |
| RRT    | Renal Replacement Therapy                          |
| RS-232 | Recommended Standard 232 (serial port)             |
| s      | Seconds  |
| Screen | Displayed information on the <b>PrisMax</b> system |
| SCUF   | Slow Continuous Ultrafiltration                    |
| ShA    | Shore A (hardness scale)                           |
| SN     | Serial Number                                      |
| SPL    | Sound Pressure Level                               |
| SST    | System Self Test                                   |
| TMP    | Transmembrane Pressure                             |
| UF     | Ultrafiltration                                    |
| UFR    | Ultrafiltration Rate                               |
| UI     | User Interface                                     |
| UL     | Underwriters Laboratories Inc.                     |
| UPC    | Universal Product Code                             |
| USB    | Universal Serial Bus                               |
| VAC    | Volts, Alternating Current                         |

|            |                       |
|------------|-----------------------|
| VDC        | Volts, Direct Current |
| W          | Watts                 |
| YYYYMMDD   | Year, month, day      |
| $\Delta P$ | Pressure drop         |

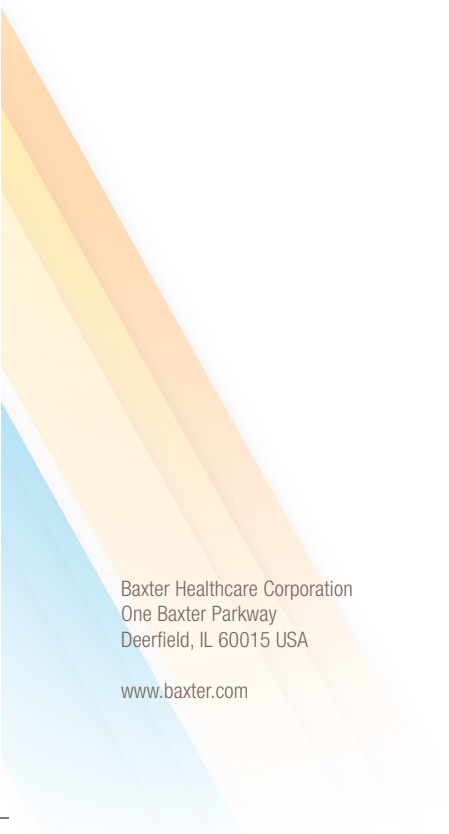

Baxter Healthcare Corporation  
One Baxter Parkway  
Deerfield, IL 60015 USA

[www.baxter.com](http://www.baxter.com)