

Julian

Anaesthetic Workstation

Instructions for Use
Software 2.n



How to use these Instructions for Use

In the header is the subject... of the main chapter.

Underneath is the title of the subchapter, to help you find your way around quickly.

On each page...

the instructions for use

combining text with illustrations. The information is translated directly into actions to enable the user to learn „hands-on“ how to use the workstation.

Left-hand column: the text...

provides explanations and guides the user clearly and ergonomically with brief directions on the use of the product.

Bullet points indicate the steps to be followed, and where there are several steps, numbers refer to the illustration and indicate the sequence.

Right-hand column: the illustration...

provides the link with the text and serves as a guide to the workstation. Points mentioned in the text are emphasised and non-essential information is omitted.

Screen displays guide the user and confirm the steps to be followed.

Operation
Selecting the ventilation mode
MAN/SPONT

- 1 Press the »MAN/SPONT« key,
- 2 and confirm with the rotary knob.

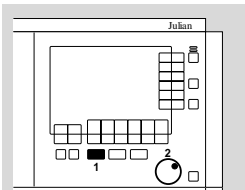

Display (example):

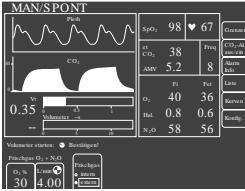

O2 flush

- For flushing and rapidly filling the breathing system and breathing bag with O2 while bypassing the Vapor unit.
- 3 Press the »O2 +« button.
O2 flows into the breathing system without anaesthetic gas as long as the button is held down.

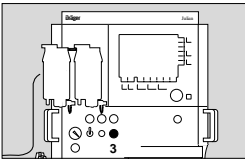

Maintenance	5, 116	Standby	47, 54
Maintenance intervals	116	Starting up	26, 33
Major hardware fault	53	Sterilization	102
MAN/SPONT	37	Suction rate	84
Manual calibration	75, 92	Switch-off time lag	54
Manual ventilation	37	Symbols	141
Measured gas recirculation system, connecting	109	System compliance	32, 39, 40, 133
Measured gas, scavenging	110		
Measuring parameters, setting	70, 84	Technical data	132
Measuring systems	133	Time	89
MEDIBUS	85	Trend memory, deleting	59
Message – Cause – Remedy	120	Trend page	17, 58
Microbial filter	97, 103		
Microbial filter 654 St	97, 103	UMDNS code	137
Mobile telephones	9	Uninterruptible power supply UPS	20, 52
Monitor defaults, activating	71		
Monitoring functions, selecting/setting	15	Vapor	27, 46
		Vapor, setting	46
Non-rebreathing systems	50	Ventilation mode	37
Nuclear spin tomography	9	Ventilation mode IPPV	40
		Ventilation mode MAN/SPONT	37
O2 concentration, setting	36	Ventilation mode PCV	43
O2 cylinders	23	Ventilation parameters for IPPV	40, 90
O2 emergency metering	30	Ventilation parameters for PCV	43, 90
O2 flush	23, 30	Ventilation parameters, selecting/setting	14
O2 sensor, replacing	117	Ventilator	132
Operating characteristics	137	Volumeter function	67
Operating concept	12		
		Wall-mounted unit	114
Paediatric hoses	49	Waste gas connector	101, 110
Patient, change	47	Water separator, replacing	117
PCV	43	Water trap	27
Power failure	20	What's what	126
Power failure	52		
Power supply	24	Zoom function	59
Preparation	22		
Pulse tone, setting	69, 83		
Record	71, 85		
Safety checks	5		
Sample line	79, 96		
Scale, selecting	69, 83		
Screen ergonomics	12		
Screen layout	16		
Secretion aspiration	30		
Secretion aspiration, dismantling	98		
Secretion aspiration, preparation	108		
Secretion, aspirating	46		
Self-test	31		
Soda lime, changing	47		
SpO2 alarms on/off	72		
SpO2 measurement	76, 135		
SpO2 sensor	76		
Spontaneous breathing	37		
Standard page	17, 56		
Standard screen	88		

Index

Abbreviations 140
Absorber, dismantling 99
Absorber, filling and installing 107
Accessories 5
Advisory 63, 120
Airway temperature measurement 80
Alarm 63, 75
Alarm info 64, 52
Alarm limits 61
Alarm sound, setting 69, 83
Alarm tone sequence 64
Alarms 63
Alarms, FRESH GAS EXTERNAL 51
Alarms, IPPV 42
Alarms, MAN/SPONT 39
Alarms, PCV 45
Alarms, selecting 60, 72
Ambient conditions 132
Anaesthetic agent 74, 93, 114
Anaesthetic agent scavenging system AGS 23, 28, 100, 111
AutoSet 62
Auxiliary devices 24
Auxiliary power socket 24

Backup gas cylinders 29
Basic configurations 88
Basic pages 17
Batteries 118
Battery 19
Bellows, installation 107
Bellows, removal 99
Breathing bag 108
Breathing hoses 108
Breathing hoses, installing 108
Breathing system 28, 133
Breathing system, dismantling 98
Breathing system, installing 106
Breathing system, opening 100

C-Lock ECG synchronization 77, 136
Calibration 75, 92
Care 96
Care list 104
Carrier gas, selecting 36
Caution 63, 120
Checking against checklist 26
Checklist 26
Children, ventilating 49
Classification 137
Cleaning 102
CO₂ alarms on/off 64, 72
CO₂ unit, setting 70, 84
CO₂, setting 84
COM1 85
COM2 85

COM3 85
Compliance 32, 133
Configuring in operation 68
Configuring in standby 82
Connection 5
Cooling air filter, cleaning 116, 117
Curves 66, 88

Data page 17, 57
Date 89
Default alarm limits, setting 86, 87
Default setting, fresh gas 91
Default setting, IPPV 90
Default setting, PCV 90
Default values 82
Disinfecting 102
Disposal 118
Disposing of the used device 118

ECG signal 77
Emergency 33, 52
Emergency metering 30
Emergency mode 52
Emergency ventilation bag 29, 101, 111
End of operation 54
Equipotential bonding 24
Explosion hazard areas 5

First-time operation 20
Flow sensor, installation 106
Flow sensor, removal 99
For your safety and that of your patients 5
Fresh gas flow, setting 36
Fresh gas metering 91, 132
Fresh gas, setting 36

Gas cylinders 23
Gas cylinders 23
Gas failure 53
Gas supply 22, 127

HLM alarm mode 73
HLM mode 73

Intended use 9
Intended use 9
Interfaces 130
Interfaces, configuring 85, 86
IPPV 40

Language 89
Leakage test 48
Liability 5
Limits 60
Limits, adjusting 62
List 65

Contents

For Your Safety and that of Your Patients 5

Intended Use 7

Operating Concept 11

Before Using for the First Time 19

Preparation 21

Starting Up 25

Operation 35

Monitoring 55

Configuring in Standby Mode 81

Care 95

Julian as Wall-mounted Unit 113

Maintenance Intervals 115

Fault – Cause – Remedy 119





















What's what 125

Technical Data 131

Abbreviations / Symbols 139

Index 142

Symbols

Symbol	Meaning
	Suppress alarm tone for 2 minutes
	Call up standard page
	Call up basic pages in succession
	Standby / operation switch
	Pulse rate
	Fresh gas flowing
	Action in progress
	Action has been completed successfully
	Repeat calibration
	Upper and lower alarm limits
	Upper alarm limit only
	Lower alarm limit only
	Alarm monitoring inactive
--	Alarm limit deactivated
* * * *	Enter 4-digit password
!	Advisory message
!!	Caution message
!!!	Warning message
	Protection class type B (body)
	Protection class type BF (body floating)
	Connection for equipotential bonding
	Connection for equipotential bonding
	Close menu, back to previous menu
	Connection for non-rebreathing systems
 >XX min	Available operating time with uninterruptible power supply UPS

Abbreviations

Abbreviation	Meaning	Abbreviation	Meaning
AGas	Anaesthetic gas	MAN/SPONT	Manual ventilation / spontaneous breathing
AGS	Anaesthesia Gas Scavenging System	MEAN	Mean pressure
AIR	Compressed air for medical use	MV	Expiratory minute volume
APL	Adjustable Pressure Limitation	N ₂ O	Nitrous oxide (laughing gas)
BTPS	Measuring condition at body temperature, current atmospheric pressure and saturated gas	NiBP	Non-invasive blood pressure
 0123	Conformité Européenne Directive 93/42/EC on Medical Products	O ₂	Oxygen
CC-Lock	The SpO ₂ signal is synchronized with the ECG signal	PAW	Airway pressure
Compl.	Compliance	PCV	Pressure Controlled Ventilation
Des.	Desflurane	PEAK	Peak pressure
etCO ₂	End-expiratory CO ₂ concentration	PEEP	Positive end-expiratory pressure
Enf.	Enflurane	PLAT	Plateau pressure
Fet	End-expiratory fraction	Pleth	Plethysmogram
Fi	Inspiratory fraction	Pmax	Maximum pressure
Fi Des	Inspiratory desflurane concentration	Sev.	Sevoflurane
Fi Enf	Inspiratory enflurane concentration	SpO ₂	Functional O ₂ saturation
Fi Hal	Inspiratory halothane concentration	Tip:Ti	Ratio of inspiratory pause time to inspiration time
Fi Iso	Inspiratory isoflurane concentration	Ti:Te	Ratio of inspiration time to expiration time
Fi Sev	Inspiratory sevoflurane concentration	USV	Uninterruptible power supply
FLOW	Expiration flow	VAC	Vacuum (e.g. for secretion aspiration)
Fi O ₂	Inspiratory O ₂ concentration	Vt	Tidal volume
Hal.	Halothane	ZV	Piped medical gas supply for O ₂ , N ₂ O, AIR and vacuum
HLM	Alarm mode for heart-lung machine		
INOP	Function failure		
IPPV	Intermittent Positive Pressure Ventilation		
Iso.	Isoflurane		

For Your Safety and that of Your Patients

Strictly follow the Instructions for Use

Any use of the apparatus requires full understanding and strict observation of these instructions. The apparatus is only to be used for purposes specified here.

Maintenance

The apparatus must be inspected and serviced regularly by trained service personnel at six monthly intervals (and a record kept). Repair and general overhaul of the apparatus may only be carried out by trained service personnel. We recommend that a service contract be obtained with DrägerService and that all repairs also be carried out by them. Only authentic Dräger spare parts may be used for maintenance. Observe chapter "Maintenance Intervals".

Accessories

Do not use accessory parts other than those in the order list.

Not for use in areas of explosion hazard

This apparatus is neither approved nor certified for use in areas where combustible or explosive gas mixtures are likely to occur.

Safe connection with other electrical equipment

Electrical connections to equipment which is not listed in these Instructions for Use should only be made following consultations with the respective manufacturers or an expert.

Liability for proper function or damage

The liability for the proper function of the apparatus is irrevocably transferred to the owner or operator to the extent that the apparatus is serviced or repaired by personnel not employed or authorized by DrägerService or if the apparatus is used in a manner not conforming to its intended use.

Dräger cannot be held responsible for damage caused by non-compliance with the recommendations given above. The warranty and liability provisions of the terms of sale and delivery of Dräger are likewise not modified by the recommendations given above.

Dräger Medizintechnik GmbH

Abbreviations / Symbols

Contents

Abbreviations.....	140
Symbols	141

Intended Use

Contents

Intended Use..... 9

Operating data

Operating voltage	90 – 265 V~
Power input	400 W typically, max. 2.3 kW
Uninterruptible power supply	with fully charged battery: typically 30 min (auxiliary sockets are not powered!)
Mains fuse	Automatic circuit-breaker 10 A
Auxiliary sockets	Each with two fuses 2 A T2L 250V DIN 41662, IEC 127-2/III
Medical gas supply	
O ₂	2.7 to 5.5 bar
N ₂ O	2.7 to 5.5 bar
AIR	2.7 to 5.5 bar
Drive gas consumption	
Operation	MV ±1 L/min AIR or O ₂
Standby and MAN/SPONT	0 L/min
Dimensions of Julian W x H x D	68 cm x 133 cm x 68 cm
Dimensions of the storage tray W x D	43 cm x 29 cm
Dimensions of the breathing system W x H x D	31 cm x 35 cm x 21 cm
Weight of Julian (Ready for operation without Vapor units and gas cylinders)	Approx. 90 kg
Weight of breathing system without soda lime	4.8 kg
Screen	Electro-luminescent screen, 10.4" diagonal
Protection class	
Device	I, type B conforming to EN 60601-1
SpO ₂ sensor	Type BF  electrically isolated from protective earth
Electromagnetic compatibility EMC	Tested to EN 60601-1-2
Classification according to Directive 93/42/EC Appendix IX	II b
UMDNS Code Universal Medical Device Nomenclature System	10-134

Sensors Type	Compatible with Nellcor sensors Oxisensor, Oxiband and Durasensor
Wavelengths	660 nm (red) 920 nm (infrared)
Acoustic pulse signal	A tone is produced for each detected pulse, tone pitch proportional to oxygen saturation

C-Lock-ECG synchronization (optional)

Requirements for ECG synchronization signal	Pos. pulse with voltage >4.5 V, >10 ms duration for driving 2 mA
---	---

Max. permissible signal delay with reference to current QRS complex	40 ms
---	-------

Socket for 2-pin jack-plug, dia. 3.5

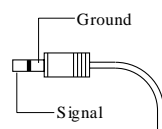

Jack layout	
Signal isolation from other electronic components	Dielectric strength 4 kV

Interfaces

Analog output Plug connector PAW Flow CO ₂ Earth	9-pin sub-D, electrical isolation 1.5 kV 0 to 100 mbar; 0 to 5 V=; PIN 3 0 to 150 L/min; 0 to 5 V=; PIN 6 0 to 10 kPa; 0 to 5 V=; PIN 9 PIN 1, 4, 7
--	---

COM1 record (printer) Connector Pin assignment	9-pin sub-D, electrical isolation 1.5 kV 1 shield 2 TxD 3 RxD 5 GND
--	---

COM2 (MEDIBUS 1) Connector Pin assignment	9-pin sub-D, electrical isolation 1.5 kV 1 shield 2 TxD 3 RxD 5 GND
---	---

COM3 (MEDIBUS 2) Connector Pin assignment	9-pin sub-D, electrical isolation 1.5 kV 1 shield 2 TxD 3 RxD 5 GND
---	---

Intended Use

Julian Anaesthetic Workstation for patients with a body weight of 5 kg and over with the use of IPPV ventilation.

For the use of:

- Inhalation anaesthesia in rebreathing systems
- Inhalation anaesthesia in semi-closed to virtually closed systems with "low flow" and "minimal flow" techniques (for minimal gas and anaesthetic agent consumption).
- Inhalation anaesthesia in non-rebreathing systems, with separate fresh gas outlet for the connection of e.g. the Bain system or Magill system

with a fresh gas flow of 0.5 to 12 L/min.

Ventilation modes:

- Automatic ventilation (IPPV) and pressure-controlled ventilation (PCV).
- Manual ventilation (MAN).
- Spontaneous ventilation (SPONT).

The following measured values are displayed:

- Peak pressure, mean pressure, plateau pressure and PEEP
- Expiratory minute ventilation
Tidal volume V_T
Breathing rate
Patient compliance
- Inspiratory and expiratory concentration of O₂, N₂O, anaesthetic gas and CO₂

optional:

- Functional oxygen saturation (SpO₂) and pulse rate.

The following parameters are displayed as curves:

- Airway pressure
- Expiratory flow
- Inspiratory and expiratory concentration of O₂, CO₂ and anaesthetic gas

optional:

- Plethysmogram

Trend curves and measured value lists are also available.

Monitoring

by means of adjustable alarm limits that are automatical adapted to the ventilation mode.

The workstation may only be used under the supervision of qualified medical personnel, so that assistance can be provided immediately in the event of any malfunctions.

Explosive anaesthetics, such as ether or cyclopropane, must not be used due to the risk of fire.

Mobile radio telephones must not be used within 10 metres of the workstation!

Mobile telephones may interfere with the operation of electrical and electronic medical equipment.

Julian must not be used with nuclear spin tomography (MRT, NMR, NMI)!

Operation of the apparatus may be impaired.

Anaesthetic gas measurement

(infrared spectrometry)

Sample rate (selectable)	60 mL/min or 200 mL/min
Delay time for sampling	Less than 1 s
Display range for N ₂ O	0 to 100 vol%
Accuracy	Better than ±2.5 vol% absolute or 4 % of measured value
Resolution	0.1 vol%
Display range for halothane and isoflurane	0 to 8.5 vol%
Accuracy for	
0 to 4 vol%	Better than ±0.2 vol% absolute
4 to 8.5 vol%	Better than 10 % of measured value
Display range for enflurane and sevoflurane	0 to 9.9 vol%
Accuracy for	
0 to 4 vol%	Better than ±0.2 vol% absolute
4 to 9.9 vol%	Better than 10% of measured value
Display range for desflurane	0 to 22 vol%
Accuracy for	
0 to 8 vol%	Better than ±0.4 vol% absolute
8 to 22 vol%	Better than 10 % of measured value
Response time t _{10...90}	
at 200 mL/min	350 ms
at 60 mL/min	1 s
Warm-up phase	4 min (accuracy as specified by DIN ISO 11196) for first measured values
Zero drift	Within the ranges specified above
Automatic anaesthetic gas identification	The measurement accuracy required by ISO standards is attained at the latest 4 minutes after switching on the apparatus. The threshold level for automatic identification equals 0.15 % by volume. Anaesthetic gases are identified from a concentration of 0.4 % by volume upwards. If a mixture is present, the gas with the higher concentration is measured.

SpO₂ measurement, optional

(light absorption)

Display range	0 to 100 % SpO ₂
Accuracy (adults)	
between 70 and 100 % SpO ₂	Better than ±2 % SpO ₂
between 50 and 70 % SpO ₂	Better than ±3 % SpO ₂
between 0 and 50 % SpO ₂	Not specified
Accuracy (neonates)	
between 70 and 95 % SpO ₂	Better than ±3 % SpO ₂
between 0 and 70 % SpO ₂	Not specified
between 95 and 100 % SpO ₂	Not specified
Actualization time	Once per heartbeat
Pulse rate	20 to 250 per minute
Accuracy	±2 per minute

Flow measurement

(hot wire anemometry)

Tidal volume VT

Range	0.02 to 9.99 L
Resolution	0.01 L
Accuracy (under calibration conditions and 1013 hPa)	Better than $\pm 8\%$ of the measured value or 0.01 L, the larger value applies

Minute volume MV

Range	0 to 99.9 L/min
Resolution	0.1 L/min
Accuracy (under calibration conditions and BTPS*)	Better than $\pm 8\%$ of the measured value

Respiration rate

Range	0 to 60 per minute
Resolution	± 1 per minute
Accuracy	± 1 per minute

Airway temperature measurement

(NTC resistance)

Measuring range	20 to 50 °C
Resolution	1 K
Accuracy	± 0.5 K in the range from 30 to 41 °C

CO₂ measurement

(infrared spectrometry)

Sample rate (selectable)	60 mL/min or 200 mL/min
Delay time for sampling	Less than 1 s
Measuring range	0 to 9.9 kPa (0 to 80 mmHg)
Resolution	0.1 kPa
Accuracy	± 0.2 vol% or 5 % of measured value
Response time t _{10...90}	
at 200 mL/min	300 ms
at 60 mL/min	1 s
Warm-up phase	4 min (accuracy as specified by DIN EN 864) 2 min for first measured values
Zero drift	Within the ranges specified above

Operating Concept

Contents

Screen ergonomics..... 12
 Selecting / setting ventilation parameters..... 14
 Selecting / setting monitoring functions..... 15

Screen layout..... 16
 Three basic screens for monitoring..... 17
 The standard screen..... 17
 The data screen..... 17
 The trend screen..... 18

* BTPS: Body temperature, current atmospheric pressure, gas saturated

Operating Concept

Screen ergonomics

All the settings required for

- Fresh gas delivery
- Ventilation
- Monitoring

are entered on the system screen using the appropriate keys and the rotary knob.

The keys are grouped in function fields:

Left-hand field
Fresh gas delivery

Right-hand field
Ventilation

Middle field
Monitoring

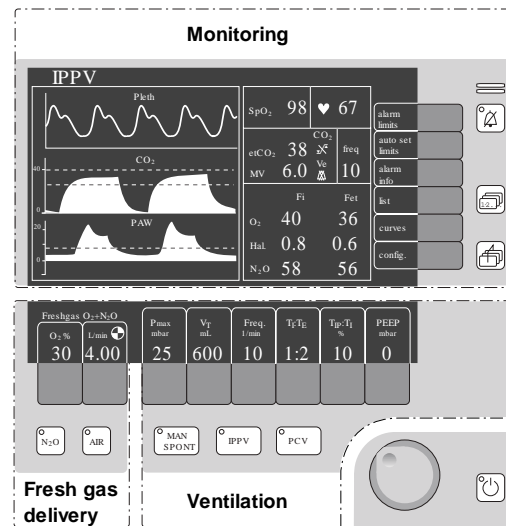

The main functions for anaesthesia, e.g. selection of N₂O or AIR, or selection of ventilation modes, can be selected directly by keys with permanently defined functions ("hardkeys"):

- 1 Left-hand block**
The »N₂O« or »AIR« keys are used to select the gas to be mixed with O₂ for the fresh gas mix.
- 2 Right-hand block**
The »MAN SPONT«, »IPPV« oder »PCV« keys select the ventilation mode.

These function keys are located in the bottom row on the control panel.

Left-hand block for fresh gas setting
Right-hand block for ventilation

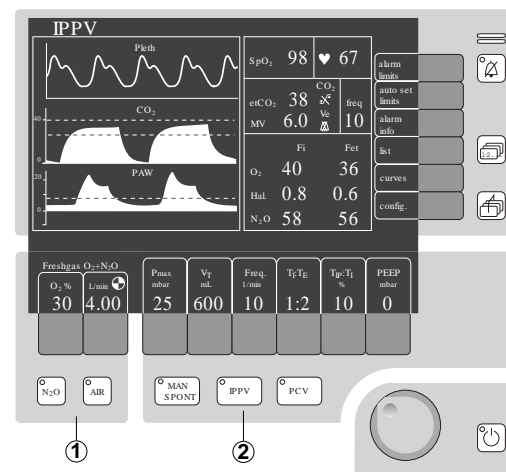

Breathing system

Total gas volume	Approx. 4.5 L enclosed gas volume
Compliance with filled absorber container, without breathing hoses	Approx. 4.5 mL/mbar
Absorber volume	1.5 L
Leakage (EN 740)	<150 mL/30 mbar
Pressure limiting valve APL Adjustment range	5 to 70 mbar ±15 % of setting
Exp. resistance (EN 740)	4.87 hPa at 60 L/min
Insp. resistance (EN 740)	4.65 hPa at 60 L/min
absorber container filled with DrägerSorb 800	

Measuring systems

Pressure measurement (piezoresistive)

Airway pressure	-10 to 99 mbar
Resolution	1 mbar
Accuracy	Better than ±4 % of measured value or at least 1 mbar, the larger value applies.

O₂ measurement (fuel cell in sidestream)

Sample rate	60 mL/min or 200 mL/min
Delay time for sampling	Less than 1 second
Measuring range	5 to 100 vol%
Resolution	1 vol%
Accuracy	Calibration in air: ±3 vol% in the range from 5 to 50 vol% ±5 vol% in the range from 50 to 100 vol% Calibration with 100 % O ₂ : ±3 vol% in the range from 5 to 100 vol%
Drift	Within the ranges specified above
Response time t10...90	
at 200 mL/min	500 ms
at 60 mL/min	1 s

Technical Data

Ambient conditions

In operation:	
Temperature	10 to 35 °C
Air pressure	700 to 1060 hPa
Rel. humidity	20 to 80 % (no condensation)
CO ₂ concentration of ambient air	300 to 800 ppm

In storage:	
Temperature	-20 to 60 °C
	O ₂ sensor max. 50 °C
Air pressure	500 to 1100 hPa
Rel. humidity	<98 % (no condensation)

Fresh gas

(electronic mixer)

Settings:	
O ₂ concentration	25 to 100% by vol., at least 25% by vol., 250 mL/min. ± 5% of set value
Fresh gas flow	0 and 0.5 to 12 L/min ± 10% of set value or max. ±100 mL
O ₂ flush	>35 L/min

Ventilator

(electronically controlled, pneumatically driven bellows in bottle ventilator)

Settings:	
Pressure limit P _{max} for IPPV	10 to 70 mbar ±10 % of setting or at least ±2 mbar
for PCV	(PEEP+1) to 70 mbar ±10 % of setting or at least ±2 mbar
Tidal volume	50 to 1400 mL ± 15% of the setting for inspiration flows ≥ 10 L/min.
Ventilation frequency	6 to 60 per minute
T _{insp}	0.2 to 6.7 seconds
T _{exp}	0.33 to 8 seconds
Insp/Exp. time ratio T _I : T _E	1 : 4 to 2 : 1 with automatic ventilation
Plateau time ratio T _{IP} : T _I	0 to 50 %
Inspiratory flow (PCV)	5 to 50 L/min ±10 % Can be set to up to 75 L/min by DrägerService
Inspiratory flow (IPPV) (cannot be set directly; depends on the setting for V _T , Freq. T _I :T _E and T _{IP} :T _I)	3 to 75 L/min
PEEP	0 to 20 mbar ±10 % of setting or at least ±2 mbar

Complementary "softkeys" with variable functions are provided at the bottom edge of the screen, above each group of hardkeys. These softkeys are used to set the fresh gas delivery parameters and ventilation parameters.

- 1 Left-hand block:**
The keys for setting the O₂ concentration and fresh gas flow.
- 2 Right-hand block:**
The keys for setting the parameters for the relevant ventilation mode. The example shows the parameters for IPPV controlled ventilation.

These softkeys have different functions, depending on the operating status or ventilation mode.

The current parameter values are displayed in the softkey field.

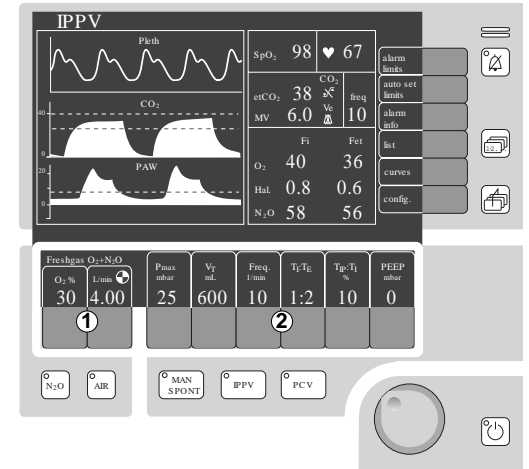



In a prominent position at the bottom right-hand side:

The "turn-and-push" rotary knob is the main operating control of the apparatus and has the following functions in all setting operations:

- 3 select = turn**
 - 4 confirm = press**
- to confirm the selected carrier gas or a ventilation mode,
 - to set and confirm the parameters for fresh gas and ventilation modes,
 - to set and confirm the monitoring functions.

Beside the rotary knob:

The standby key  for switching over to standby mode.

- 5 Press standby key  and confirm by pressing the rotary knob.**

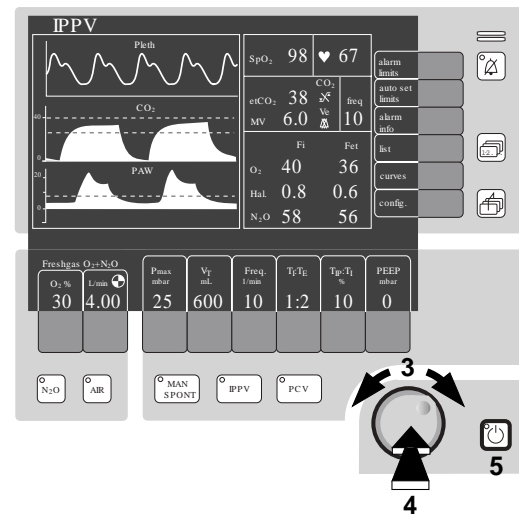

Selecting / setting ventilation parameters

Example: PEEP ventilation parameter

- 1 Press the softkey »PEEP«
- 2 Select the PEEP value = turn the rotary knob.
- 3 Confirm the PEEP value = press the rotary knob.

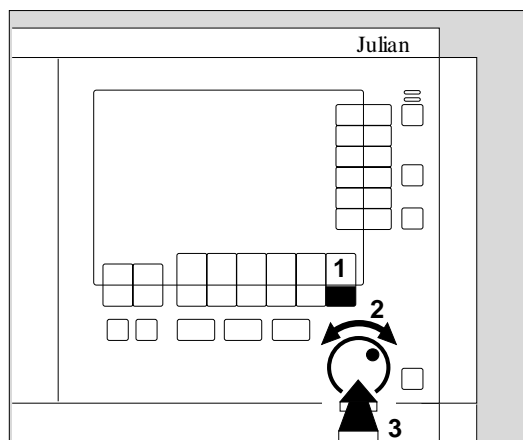

The keys for the various monitoring functions are located on the right-hand side of the screen.

These keys also have different functions = softkeys, depending on the monitoring screen required.

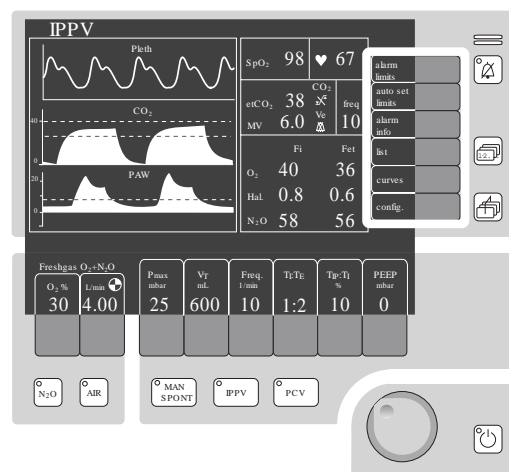

Technical Data

Contents

Ambient conditions..... 132

Fresh gas..... 132

Ventilator..... 132

Breathing system..... 133

Measuring systems..... 133

Pressure measurement 133

O2 measurement..... 133

Flow measurement..... 134

Airway temperature measurement..... 134

CO2 measurement..... 134

Anaesthetic gas measurement..... 135

SpO2 measurement..... 135

C-Lock-ECG synchronization (optional)..... 136

Interfaces..... 136

Operating data..... 137

Interface panel

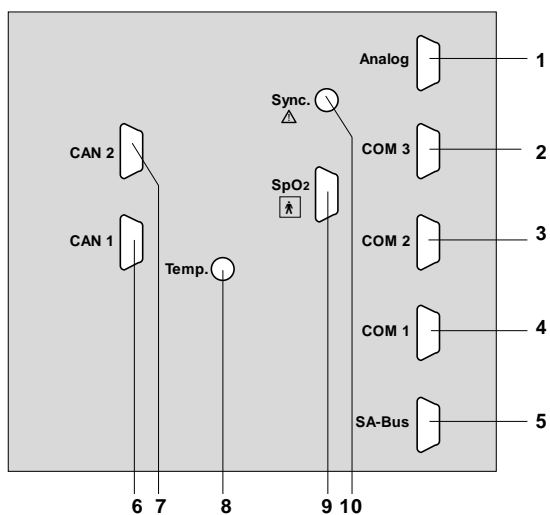

- 1 Analog Analog output for three curves
- 2 COM3 RS232 interface for MEDIBUS
- 3 COM2 RS232 interface for MEDIBUS
- 4 COM1 RS232 interface for printer
- 5 SA-Bus For DrägerService only
- 6 CAN1 Interface for PM 8060 vitara (haemodynamic screen), optional
- 7 CAN2 Interface for parameter box PB 8800, optional
- 8 Temp Socket for temperature sensor, optional
- 9 SpO2 Socket for SpO2 sensor, optional
- 10 Sync Socket for C-Lock-ECG synchronization of the optional SpO2 measurement

Selecting / setting monitoring functions

For example, to change the lower alarm limit of the end-tidal CO₂ concentration.

- 1 Press the »alarm limits« softkey. The alarm limits menu is displayed on the screen.

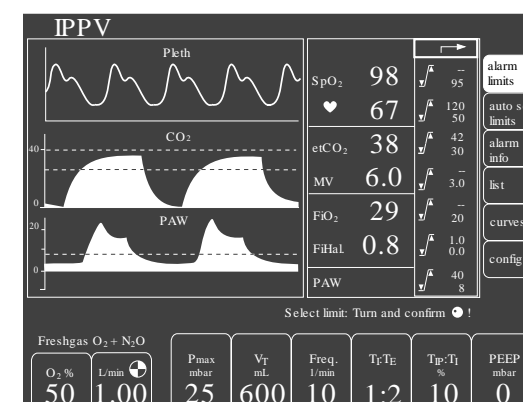
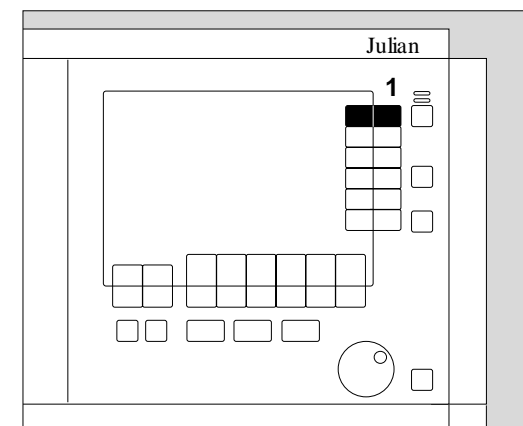

- Select the alarm limit value = turn the rotary knob. Confirm the selection = press the rotary knob. The limit value is highlighted. Example: lower alarm limit etCO₂: √/30
- Set the alarm limit value = turn the rotary knob.
- Confirm the new alarm limit = press the rotary knob. The cursor returns to the ↶ symbol.

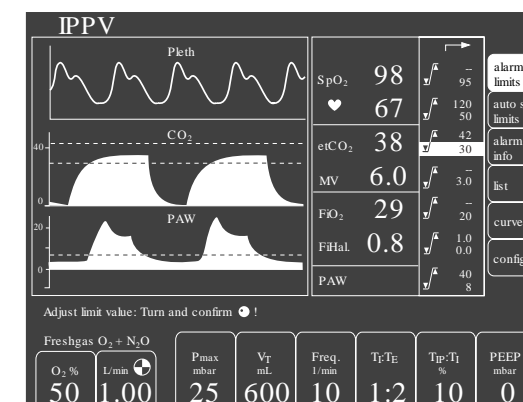

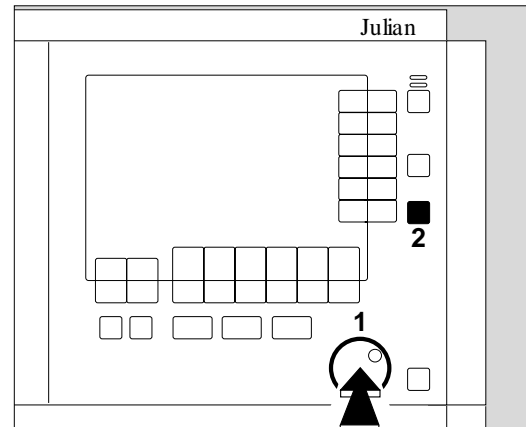

Exit the **alarm limits** menu:

- 1 Press the rotary knob
or
- 2 Press the  key.



The function keys for standard functions are located on the right-hand side of the control panel.

-  Suppress the acoustic alarm for 2 minutes.
-  Select the screen page.
-  Back to standard page.

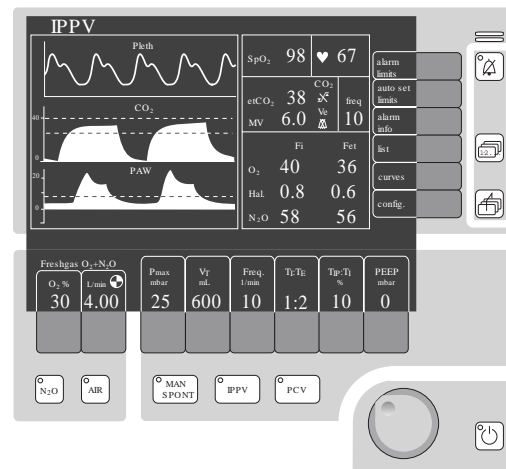

Screen layout

- ① Status field:
Displays information on the current operating mode
- ② Graphics field:
For curves and bargraphs
- ③ Alarm field:
Displays information on the alarms, warnings, etc. and their priority
- ④ Numerical value field:
For numerical values
- ⑤ Lower softkeys – for fresh gas parameters
- ⑥ Prompt field:
For user guidance
- ⑦ Lower softkeys – for ventilation parameters
- ⑧ Right-hand softkeys – for monitoring:
For rapid selection of the desired monitoring function

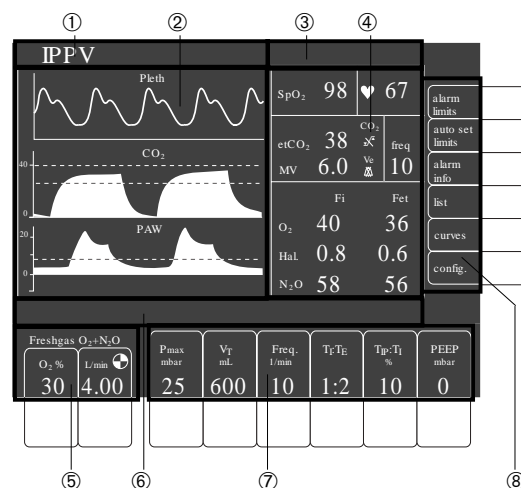

Rear view

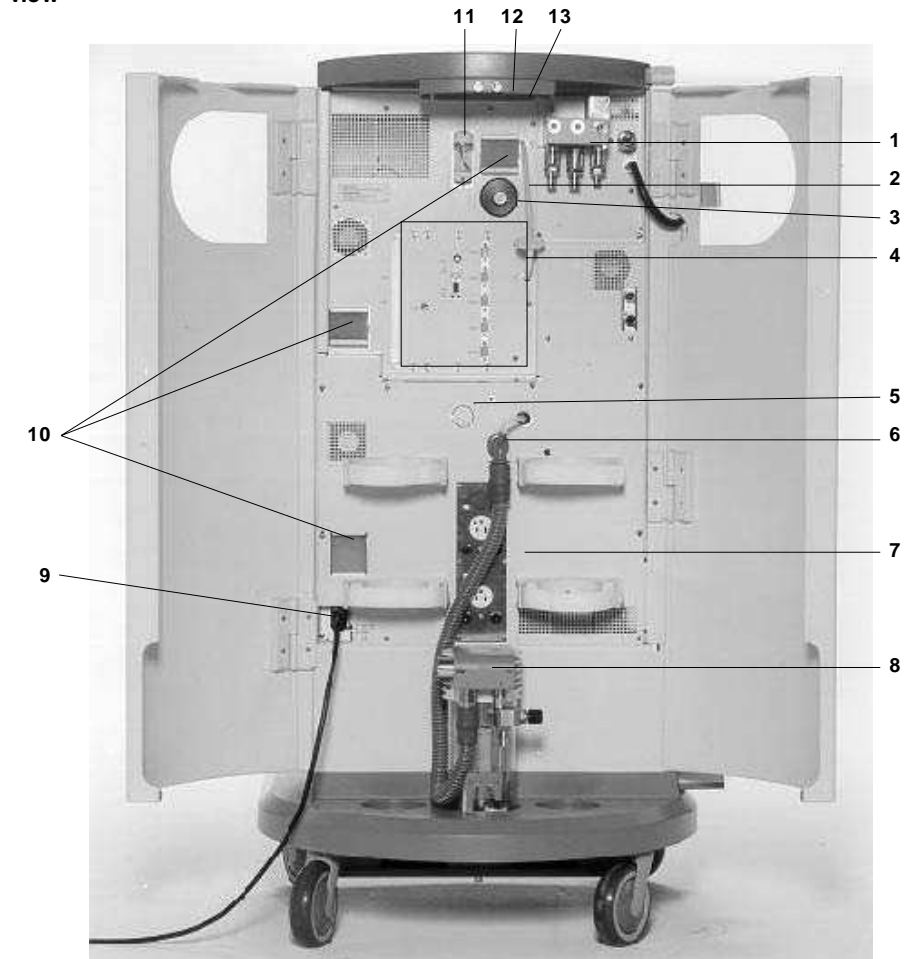

- | | |
|--|---|
| 1 Gas supply ports | 8 Anaesthetic gas scavenging system AGS |
| 2 Sample gas return with filter | 9 Power cable |
| 3 O2 sensor (behind the sealing screw) | 10 Cooling air filters |
| 4 Interface panel | 11 Connection for sample line with water separator and water trap |
| 5 Bacterial filter for suction system | 12 Auxiliary power sockets |
| 6 Waste gas connector | 13 Pin for earth cable |
| 7 Transfer hose to anaesthetic gas scavenging system AGS | |

Screen with user interface

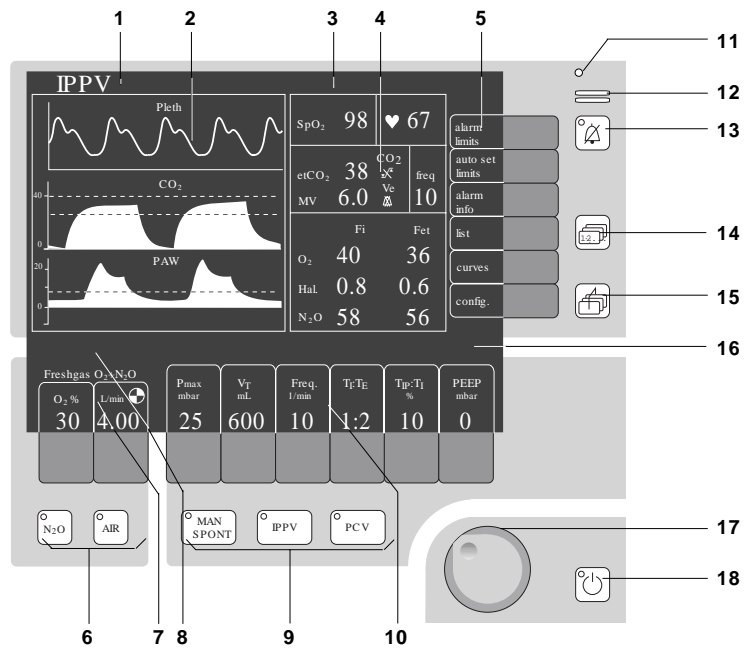

- | | |
|--|---|
| 1 Status field showing the current ventilation mode | 10 Softkeys for setting ventilation |
| 2 Curve field for curves and bar graphs | 11 Power supply indicator |
| 3 Alarm field for alarm messages and their priority | 12 Alarm indication LEDs |
| 4 Measurement field for numerical values | 13 Key for suppressing the acoustic alarm for 2 minutes |
| 5 Softkeys for monitoring functions | 14 Key for changing monitoring screen pages |
| 6 Keys for selecting the carrier gas (N ₂ O or AIR) | 15 Key for calling up the standard screen |
| 7 Softkeys for setting the fresh gas flow | 16 User advisory field |
| 8 Status line for fresh gas | 17 Rotary knob for selection, setting and confirmation |
| 9 Keys for selecting the ventilation mode | 18 Key for switching to standby mode |

Three basic screens for monitoring

To call up the **standard screen**, **data screen** and **trend screen** in succession:

1 Briefly press the key until the desired screen is displayed.

Back to the standard screen:

2 Press the key.

The fresh gas and ventilation parameters can be set by means of the softkeys in each of the three basic screens.

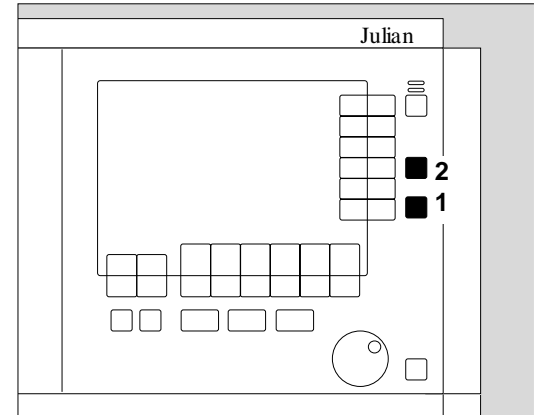

The standard screen

with three selectable curves.
The most important numerical values are displayed in groups on the right-hand side of the screen.

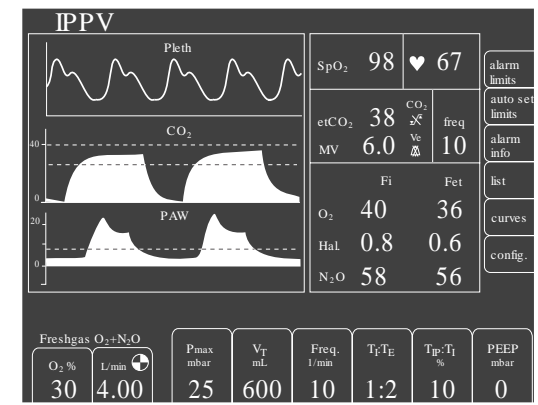

The data screen

contains all the numerical values with their units of measure.

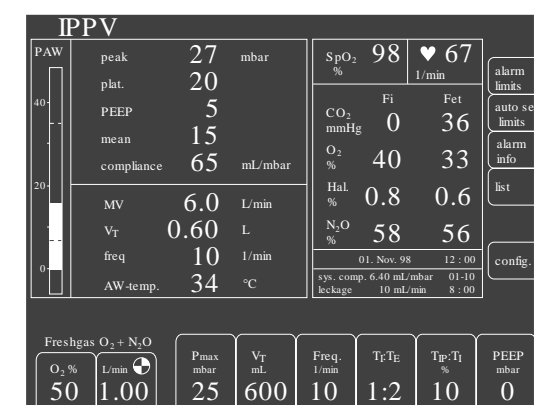

The trend screen

displays the recorded progress of the numerical values over time since measurement started. The current measured values are displayed on the right-hand side.

Display (example):

Trends for CO₂ and minute ventilation MV

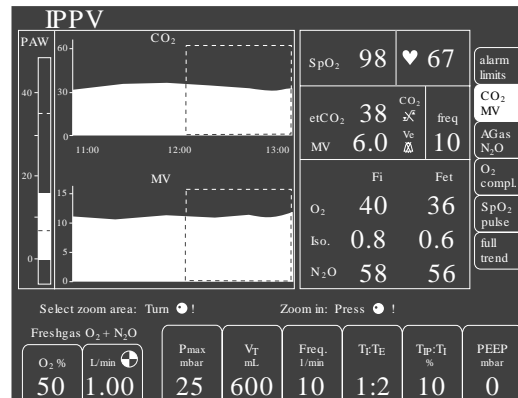

Gas supply panel

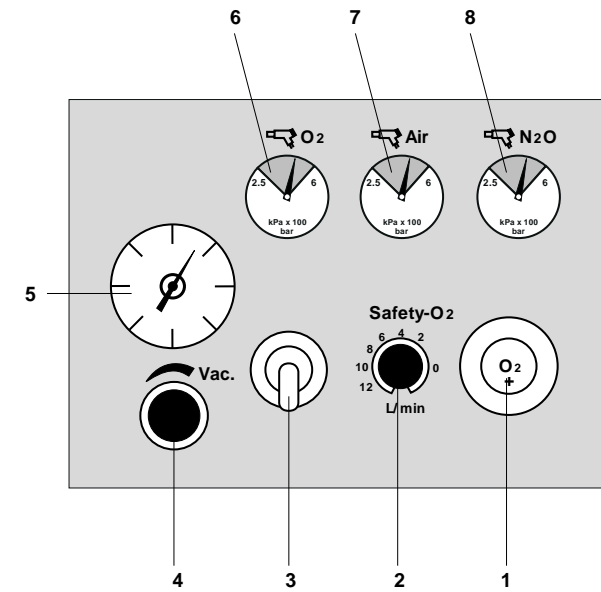

- 1 O₂ flush
- 2 O₂ emergency metering
- 3 Secretion aspiration on/off switch
- 4 Rotary knob for secretion aspiration suction
- 5 Secretion aspiration pressure gauge
- 6 Central gas supply O₂ pressure gauge
- 7 Central gas supply AIR pressure gauge
- 8 Central gas supply N₂O pressure gauge

What's what

Front view

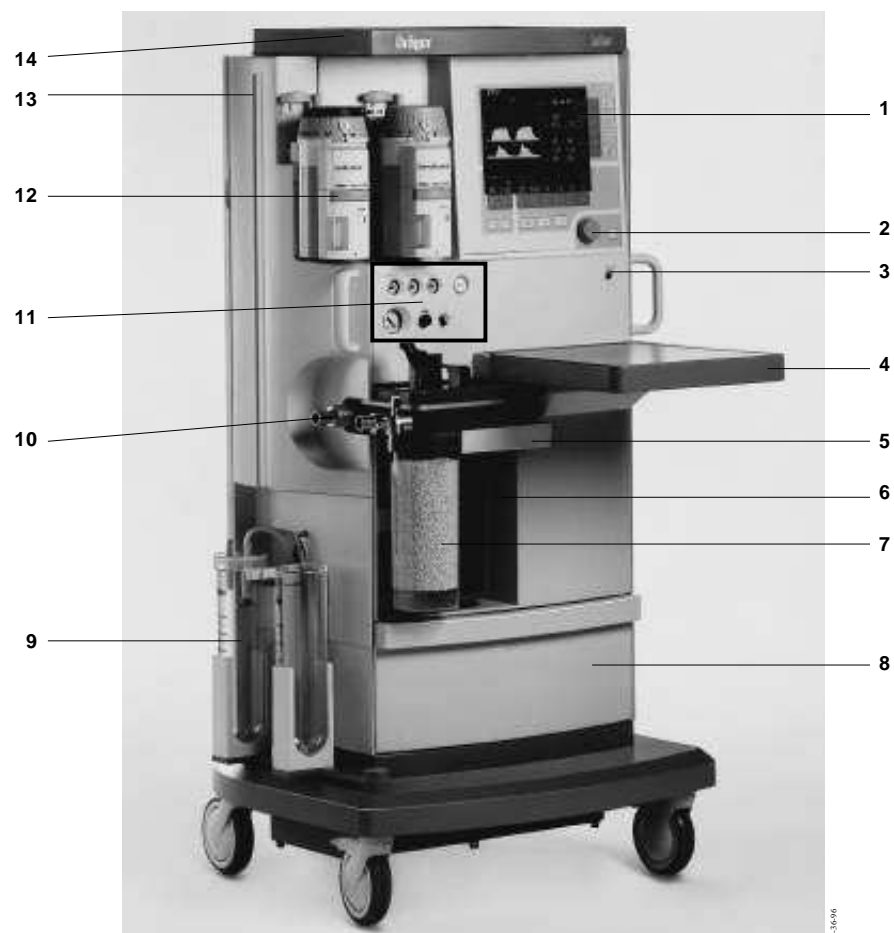

- | | | | |
|---|---|----|-------------------------------|
| 1 | Screen with user interface | 10 | Compact breathing system |
| 2 | Rotary knob for selection, setting and confirmation | 11 | Gas supply panel |
| 3 | Main power switch | 12 | Vapors with interlock system |
| 4 | Writing top | 13 | Mounting rail for accessories |
| 5 | Catch to unlock the breathing system | 14 | Shelf for patient monitor |
| 6 | Bellows | | |
| 7 | Absorber | | |
| 8 | Drawer | | |
| 9 | Suction system | | |

Before Using for the First Time

Contents

Charging the battery for emergency operation..... 20

When Julian is not in use..... 20

Before Using for the First Time
Charging the battery for emergency operation
When Julian is not in use

Before Using for the First Time

Fit the enclosed O2 sensor,
page 117 "Replacing O2 sensor"
Fit the flow sensor, page 106

Charging the battery for emergency operation

Julian has a built-in uninterruptible power supply UPS which maintains the power supply for 30 minutes in the event of a mains failure, provided that the battery is charged.

The switch-over to the battery-powered UPS is automatic and is indicated on the screen by the message: POWER FAIL!

The battery recharges automatically when the workstation is plugged into the mains.

The battery must be charged for 10 hours before using the Workstation for the first time.

- Plug the mains plug of the Julian workstation into the mains socket. The mains voltage must correspond to the voltage specified on the nameplate.

1 The green LED  lights up.

- Leave Julian connected to the mains for 10 hours. The workstation does not have to be switched on.

The devices connected to auxiliary power sockets will not be powered by the UPS in the event of a power failure.

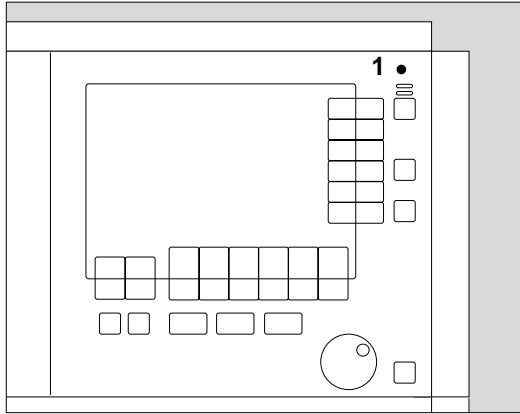

When Julian is not in use

- **Charge battery at least every 4 weeks. Allowing it to run down can lead to damage.**

If Julian is out of use for an extended period:

- Leave the workstation connected to the mains at all times.

1 The green LED  is lit.

What's what

Contents

Front view.....	126
Gas supply panel.....	127
Screen with user interface.....	128
Rear view.....	129
Interface panel.....	130

Preparation

Contents

Connecting the gas supply	22
Connecting the backup gas cylinders for O ₂ and N ₂ O	23
Caution when handling O ₂ cylinders.....	23
Connecting the anaesthetic gas scavenging system	23
Connecting the power supply	24
Connecting auxiliary systems.....	24
Equipotential bonding.....	24
Connecting the power supply.....	24

Preparation
Connecting the gas supply

Preparation

Use only cleaned and disinfected parts!

Connecting the gas supply

- 1 Screw the central gas supply pressure hoses for O₂, AIR and N₂O into the ports on the back of the gas supply block. The two ports at the front are reserved for the backup gas cylinders.
- 2 The vacuum supply block (VAC) is available as option for secretion aspiration. Plug the other end of the pressure hoses into the wall supply points.

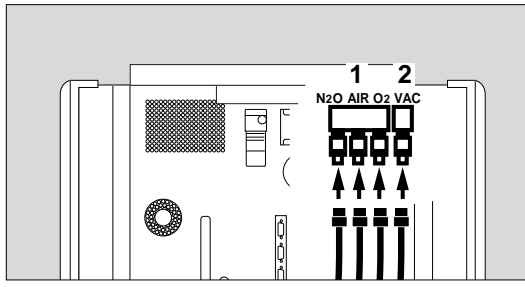

- Make sure the gas pressures of the central gas supply are between 2.7 and 5.5 bar:
- 3 All three pressure gauges in the green zone.

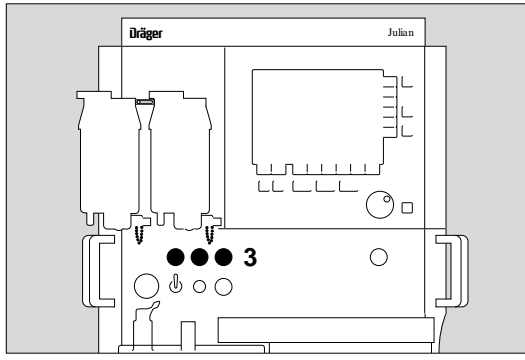

Message	Cause	Remedy
PRESSURE LIMIT	!! The ventilator is operating in pressure-limited mode. Lung compliance has changed. Tube kinked. Microbial filter clogged on the inspiratory side.	Check tube/microbial filter. If necessary, increase Pmax or reduce VT
PRESSURE ERR	! Pressure sensor defective.	Call DrägerService.
PRESSURE EXP ✓	!!! End-expiratory pressure is more than 10 mbar above the set PEEP.	Increase expiration time. Check hose system and microbial filter. Drain water trap.
PULSE SPO ₂ ✓	!!! Pulse rate has dropped below the set alarm limit.	Check patient's condition!
PULSE SPO ₂ ✓	!! Pulse rate exceeds upper alarm limit.	Check patient's condition! Correct alarm limit if necessary.
SPO ₂ ✓	!!! Oxygen saturation is below the set lower alarm limit.	Check ventilation. Check O ₂ concentration of the fresh gas.
SPO ₂ ✓	!! Oxygen saturation exceeds the upper alarm limit.	Check O ₂ concentration of the fresh gas flow. Check ventilation.
SPO ₂ INOP	! SpO ₂ measurement faulty.	Call DrägerService.
SPO ₂ PULSE ?	!!! No pulse signal detected by SpO ₂ measurement for approx. 10 seconds.	Check patient's condition! Check SpO ₂ sensor!
SPO ₂ SENSOR?	! SpO ₂ sensor not plugged in.	Check sensor connection.
SPEAKER FAIL	! No alarm tone, loudspeaker faulty.	Call DrägerService.
SYSTEM ERROR	!!! Internal device error. Automatic switchover to MAN/SPONT. Version without rotary knob for O ₂ emergency metering: Julian automatically delivers an O ₂ flow of 4 L/min. Version with rotary knob for O ₂ emergency metering: Set »Safety O ₂ « rotary knob to desired O ₂ flow. Range 0 to 12 L/min. This O ₂ flow flows through the Vapor unit.	Immediately ventilate the patient by hand. Set »Safety O ₂ « rotary knob for O ₂ emergency metering to desired O ₂ flow. Range 0 to 12 L/min. Immediately ventilate the patient by hand. Check Vapor unit setting. Call DrägerService.
VENT INOP	!!! The ventilator control unit is performing an internal restart. This restart procedure takes about 15 seconds.	After about 15 seconds, Julian is restored to its previous operating mode.
WATER TRAP	! The collecting jar of the water trap at the back of the unit is full. The prism of the water trap is misted over with condensation.	Empty the jar. Wipe the prism dry.

Message	Cause	Remedy
JULIAN COM 2	! Communication via the RS 232 interface COM 2 has been interrupted.	Check the plug connection on Julian and the connected device.
MV ✓	!! Minute volume below the lower alarm limit. Tube blocked/kinked. Leak in breathing system. Ventilation volume reduced by pressure limitation. Inadequate fresh gas flow.	Check breathing system. Check setting of ventilator. Check tube. Seal breathing system. Correct ventilation pattern. Increase fresh gas flow.
MV ✓	!! Minute volume exceeds upper alarm limit.	Correct tidal volume or respiration rate.
MIXED AGENT	! The anaesthetic gas has been confused. Mixture of two anaesthetic agent present.	Check fresh gas setting. Wait a while.
MIXER INOP	!!! Fault in the fresh gas mixer system. Automatic switchover to MAN/SPONT. A constant flow of 4 L/min O ₂ is maintained.	Patient must immediately be ventilated by hand! Call DrägerService.
N ₂ O INOP	! N ₂ O gas measurement faulty.	Call DrägerService.
N ₂ O SUPPLY	!!! N ₂ O supply has failed. The central supply connector is not plugged in or the N ₂ O hose is kinked. N ₂ O cylinder empty.	Open the N ₂ O backup cylinder. Check connection to central supply. Restore N ₂ O supply. Connect a full N ₂ O cylinder.
NO FRESHGAS	!!! Fault on switching over to the external fresh gas outlet.	Call Dräger Service.
O ₂ INOP	! O ₂ sensor worn or defective	Replace O ₂ sensor, page 117
O ₂ SUPPLY	!!! The oxygen supply has failed. The central supply connector is not plugged in or the O ₂ hose is kinked. O ₂ cylinder empty.	Open the O ₂ backup cylinder. Check connection to central supply. Restore O ₂ supply. Connect a full O ₂ cylinder.
PAW ✓	!!! Airway pressure exceeds upper alarm limit. Ventilation hose kinked. Stenosis. Pressure limit set too high.	Check hose system. Correct pressure limit.
PAW NEGATIVE	!!! Inadequate supply of fresh gas. Mean pressure p_{mean} less than -2 mbar. Airway pressure PAW less than -7 mbar.	Set adequate fresh gas flow on the anaesthetic unit.
P MAX?	! PCV pressure limit not reached.	Check stroke volume. Correct pressure limit, inspiratory flow or inspiration time if necessary.
POWER FAIL	! Power supply failure. Short-circuit in one of the devices connected to the auxiliary sockets.	Check battery capacity. Prepare manual ventilation. Remove the device plug from the auxiliary sockets. Press the switch on the back panel.

Connecting the backup gas cylinders for O₂ and N₂O

Even if the workstation is connected to a central gas supply, the cylinders must remain on the apparatus as backup supply.

- On the back of the workstation:
place full cylinders in the cylinder holders and secure in position.
- 1 Screw the pressure reducing adapters onto the cylinder valves.
 - 2 Screw the gas hoses into the ports on the front of the gas supply block.

Switch over immediately to cylinder supply if the central gas supply fails:

- Open the cylinder valves.

Caution when handling O₂ cylinders

- Do not oil or grease the O₂ cylinder valves or O₂ pressure reducing adapters, and do not handle with greasy fingers.
Danger of explosion!
- The cylinder valves must be opened / closed by hand. Do not use tools.
- If a cylinder valve is leaky or difficult to operate, it must be repaired by an expert.

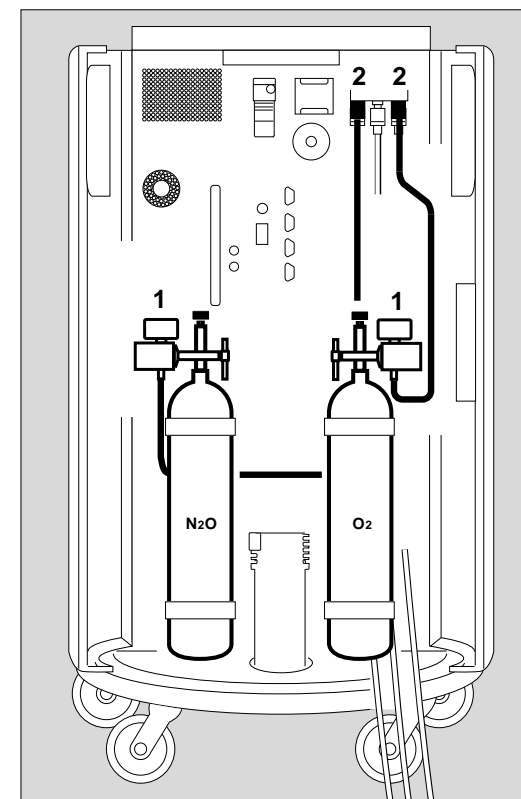

Connecting the anaesthetic gas scavenging system

- 3 Connect the transfer hose to the waste gas port and to the port of the scavenging system.
 - 4 Connect the scavenging hose to the port of the scavenging system.
 - 5 Connect the anaesthetic waste gas probe to the aspirating hose.
 - 6 Ensure that the second connection to the scavenging system is sealed by a screw plug.
- Follow the Instructions for Use of the anaesthetic gas scavenging system.

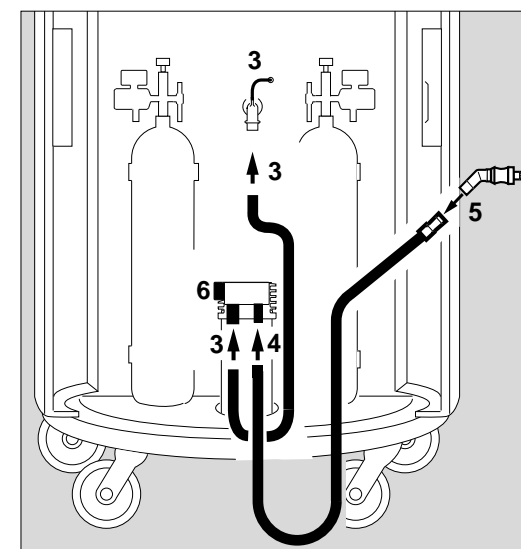

Connecting the power supply

Connecting auxiliary systems

1 connect to auxiliary sockets on the back of the workstation.

The auxiliary sockets are not powered by the uninterruptible power supply UPS in the event of a power failure!

Do not connect HF surgical devices to the auxiliary sockets!

Connecting equipment to the auxiliary sockets may cause the patient leakage current to rise above the permitted values in the event of failure of a protective earth conductor.

The risk of electric shock cannot be excluded in such cases.

Additional power adapter sockets must not be connected to the auxiliary sockets.

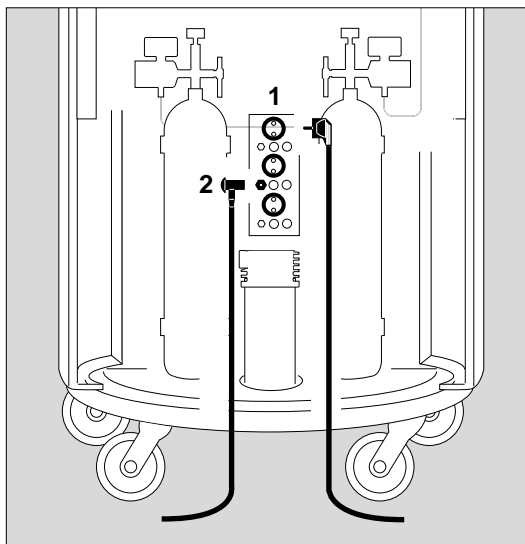

Equipotential bonding

e.g. for intracardial or intracranial operations.

2 Connect one end of the earth cable to one of the connecting pins on the back of the workstation.

- Connect the other end of the earth cable to the specified equipotential bonding point, e.g. on the operating table or ceiling lamp.

Connecting the power supply

The mains voltage must be the same as specified on the nameplate on the back of the workstation.

Voltage range: 90 to 265 V

- Plug the mains plug into the wall socket.

Message	Cause	Remedy
CO ₂ /AGA INOP	! CO ₂ / anaesthetic gas measurement faulty, and consequently: aspiratory O ₂ measurement faulty.	Call DrägerService.
CO ₂ INOP	! CO ₂ gas measurement faulty.	Call DrägerService.
CO ₂ LINE?	! Sample line blocked.	Check sample line, filter in T-piece and water separator; replace if necessary. Check that hose to anaesthetic gas scavenging system is not kinked.
COOLING ?	! Internal temperature in apparatus is too high or fan for mixer electronics is defective.	Clean filter on the back panel. Call DrägerService.
EMERGENCY O ₂ OPEN	! O ₂ emergency metering has opened in normal operation.	Close O ₂ emergency metering.
ET CO ₂ ✓ [^]	!! Upper alarm limit for end-expiratory CO ₂ concentration has been exceeded for at least two breaths.	Check ventilation.
ET CO ₂ ✓	!! End-expiratory CO ₂ concentration has fallen below lower alarm limit for at least two breaths.	Check ventilation.
FI HAL ✓ [^]	!!! The inspiratory gas concentration of the relevant anaesthetic agent exceeds the upper alarm limit.	Check setting of anaesthetic vaporizer.
FI ISO ✓ [^]	!!! The upper alarm limit has been exceeded for at least two breaths.	
FI ENF ✓ [^]	!!!	
FI DES ✓ [^]	!!!	
FI SEV ✓ [^]	!!!	
FI HAL ✓	!! Inspiratory gas concentration of the relevant anaesthetic agent is below the lower alarm limit.	Check setting of anaesthetic vaporizer.
FI ISO ✓	!! The value has remained below the lower alarm limit for at least two breaths.	
FI ENF ✓	!!	
FI DES ✓	!!	
FI SEV ✓	!!	
FI O ₂ ✓	!!! Inspiratory O ₂ concentration is below the lower alarm limit.	Check O ₂ supply.
FI O ₂ ✓ [^]	!! Inspiratory O ₂ concentration exceeds upper alarm limit. O ₂ flush used.	Check O ₂ concentration in fresh gas flow.
FI O ₂ INOP	! Aspirating O ₂ measurement defective. O ₂ sensor exhausted. O ₂ sensor not used.	Call DrägerService. Replace O ₂ sensor, page 117. Use O ₂ sensor, page 117.
FLOW INOP	! Flow sensor defective.	Replace flow sensor, page 106.
GAS FAILURE	!!! Failure of the O ₂ and AIR supply.	Open backup O ₂ cylinder. Check connection to central supply.
INSP CO ₂ ✓ [^]	!! The inspiratory CO ₂ concentration exceeds the fixed upper limit of 5 mmHg.	Replace the soda lime in the anaesthetic unit system. Valve discs in breathing system defective. Set sample rate to 200 mL/min due to high frequency and time constant of CO ₂ sensor.

Fault – Cause – Remedy

Julian divides the alarm messages into three priority classes identified by exclamation marks:
 !!! Warning = Message with top priority
 !! Caution = Message with middle priority
 ! Advisory = Message with least priority

The messages are listed below in alphabetical order. The list is intended to help identify the cause of an alarm message and to remedy the fault rapidly.

Message	Cause	Remedy
AGAS INOP	! Anaesthetic gas measurement faulty.	Call DrägerService.
AGT NOT SEL	! The manually selected anaesthetic gas does not correspond to the gas identified by the measurement.	Check and select the anaesthetic agent or switch over to automatic anaesthetic gas identification.
AIR SUPPLY or AIR SUPPLY	!!! Compressed air supply has failed. Central supply connector not plugged in. Compressed air hose kinked. Air compressor failure.	Check connection to central supply. Check compressor.
APNEA CO2	!!! Breathing/ventilation has stopped. No breath detected for 30 seconds. No breath detected for 60 seconds in the "MAN/SPONT alarm limits" alarm mode.	Patient must immediately be ventilated by hand! Check ventilator setting. Ensure it is not disconnected. Patient must immediately be ventilated by hand! Check patient's spontaneous breathing ability.
APNEA PRESSURE	!!! Breathing/ventilation has stopped. No change of pressure detected for 15 seconds. Inadequate supply of fresh gas. Leak in hose system.	Patient must immediately be ventilated by hand! Check fresh gas setting. Check that hose system is not disconnected.
APNEA VOL	!!! Breathing/ventilation has stopped. No expiratory tidal volume for 15 seconds. Inadequate supply of fresh gas. Tube kinked.	Patient must immediately be ventilated by hand! Check patient's spontaneous breathing ability. Check ventilator setting. Check fresh gas setting. Check hose system.
AW Temp \sqrt{F}	!!! Breathing gas temperature above 40 °C.	If using a breathing gas humidifier: disconnect humidifier. If using heated breathing hoses: remove plug of hose heater.
AW TEMP INOP	! Airway temperature sensor defective.	Check sensor lead. Replace sensor.
BATTERY LOW	!!! The battery capacity of the uninterruptible power supply is almost exhausted.	Check patient's condition! Prepare manual ventilation with 100 % O2.

Starting Up

Contents

Checking the workstation against the checklist..... 26
 Switching on..... 26

Gas pressures.....29
 Central gas supply..... 29
 Backup gas cylinders..... 29
 Suction system.....30
 O2 flush 30
 O2 emergency metering..... 30
 Preparing Julian for the self-test..... 31

Self-test.....31
 Electronics..... 31
 Fresh gas mixer.....31
 Ventilator and breathing system 31

System compliance..... 32
 Leakage..... 32

Emergency start..... 33

Starting Up

Checking the workstation against the checklist

Preconditions:
 The workstation must be prepared as described on pages 95 to 105 and assembled ready for operation as described on pages 106 to 111.
 The gas supply and power supply must be connected.

Switching on

- 1 Switch on Julian: press the power switch »  «

Version without rotary knob for O₂ emergency metering:

After switching on, Julian delivers an O₂ flow of 4 L/min for manual ventilation.
 This O₂ flow is switched off automatically by Julian as soon as the »cancel test« key appears after acknowledging the checklist.

The opening screen appears with the current software version after about 10 seconds. Julian now loads its software and tests its internal memory.

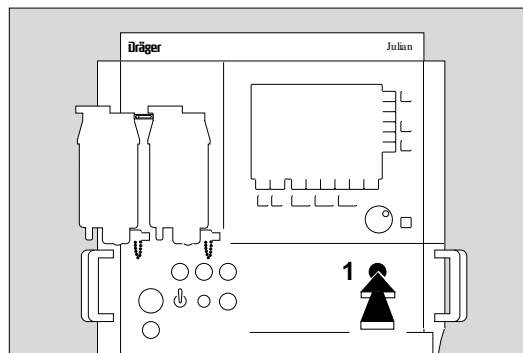

The checklist is displayed after about 40 seconds.

- Check the components as instructed in the checklist on the screen.

If the self-test has to be interrupted, e.g. for a quick start in an emergency:

- Acknowledge the checklist:

Press the rotary knob.
 After a few seconds, the »cancel test« softkey appears on the right-hand edge of the screen.

- Press the »cancel test« key. See "Emergency start" on page 33 to continue.

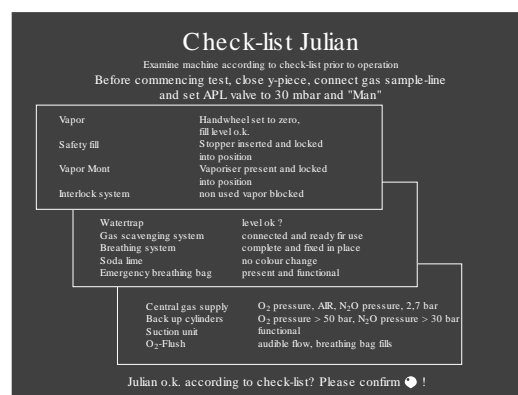

Fault – Cause – Remedy

Contents

Fault – Cause – Remedy..... 120

Disposing of batteries and O₂ sensors

Batteries and O₂ sensors:

- must not be incinerated or thrown into a fire – risk of explosion!
- must not be opened forcibly – danger of chemical burns!
- must not be recharged.

Batteries must be handled as special waste:

- They must be disposed of in conformity with the local waste disposal regulations.

Spent O₂ sensors can also be returned to Dräger Medizintechnik GmbH.

Disposing of the used device

– At the end of its useful life.

Julian can be returned to Dräger Medizintechnik GmbH for disposal.

"Vapor" anaesthetic vaporizer (example: Vapor 19.3)

Only use Vapor 19.3, Vapor 2000 or Devapor. Follow the Instructions for Use for the particular vaporizer used.

- 1 Handwheel to "0" and engaged.
- 2 Filled to sufficient level.
- 3 Sealing slide valve inserted and screwed tight.
- 4 The locking lever must point to the left = locked.
- 5 The unused Vapor unit must be locked by the interlock slider (example: left-hand Vapor locked).

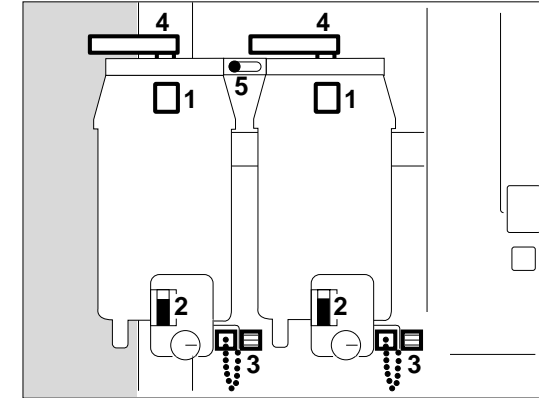

Water trap

- Remove water trap container by pulling downwards and empty if necessary.
- **Observe the hygiene regulations of the hospital.**
- Replace container from below.

When using the "Waterlock" water trap

- See separate Instructions for Use

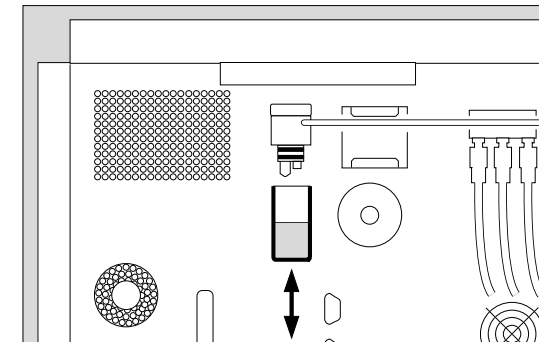

AGS anaesthetic gas scavenging system

- 1 The transfer hose from the waste gas port must be connected.
- 2 The scavenging hose must be connected; the anaesthetic waste gas probe must be plugged into the Dräger wall socket and the indicator must be green.
- 3 The float must be between the two marks.

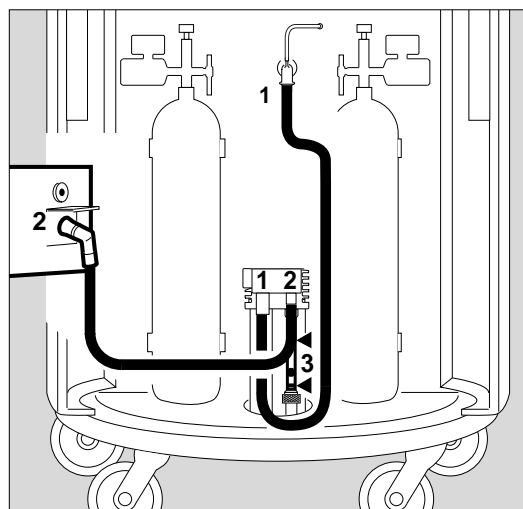

Breathing system

- Complete and engaged, with both valve discs inserted, bellows fitted and hoses securely connected.
- Soda lime renewed, **no violet discoloration**.

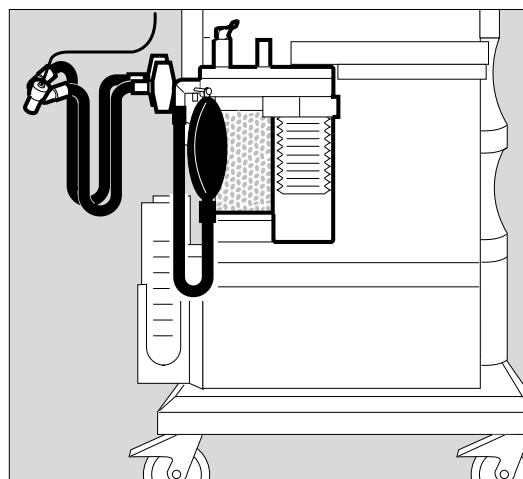

Cleaning the cooling air filters

- clean filters monthly.
- 1 Remove all three cooling air filters from their mount.
 - Clean in warm water to which a detergent has been added; dry thoroughly.
 - Insert the cooling air filters in their mount without creasing.
 - Replace the cooling air filters after not more than one year. The filters can be disposed of as domestic waste.



Replacing the water separator

- When soiled or
 - when the message **CO₂ line? !** is displayed (if the sample line is correctly installed and free of any blockage).
- Grip the water separator by its sides and pull it out.
 - Push the new water separator into the holder as far as possible.
 - The old water separator can be disposed of as domestic waste.

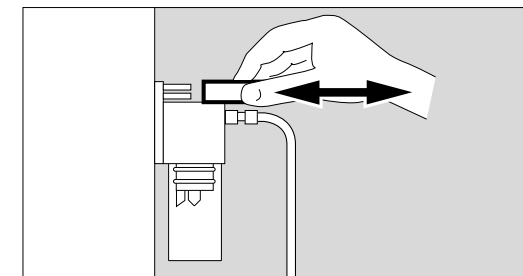

Replacing the "Waterlock" water trap:

- See separate Instructions for Use.

Replacing the O₂ sensor

- When the message **FIO₂ INOP!** is displayed or
 - when the sensor can no longer be calibrated.
- 1 Remove the screw.
 - 2 Remove the spent O₂ sensor from the screw and insert a new O₂ sensor in the screw.
 - 1 Refit the screw.
 - Dispose of the spent O₂ sensor, see page 118.

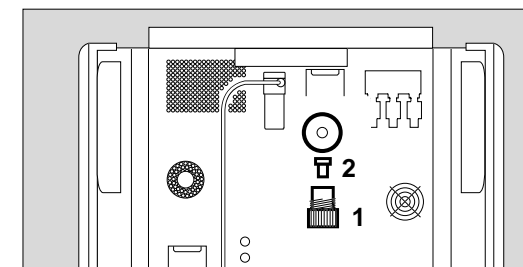

Maintenance Intervals

The workstation and its components must be cleaned and disinfected before every maintenance operation - even when returning for repair!

Water separator	Replace when dirty or when the message CO2 line?! is displayed (if the sample line is correctly installed and free of any blockage). Can be disposed of as domestic waste.
O2 sensor	Replace when calibration is no longer possible or when the message FIO2 INOP! is displayed. Disposal, see page 118.
Flow sensor	Replace when calibration is no longer possible or when the message FLOW INOP! is displayed. Can be incinerated with little pollution at temperatures of more than 800 °C.
Bacterial filter for secretion aspiration	Replace after two weeks. Must be disposed of as infectious special waste. Can be incinerated with little pollution at temperatures of more than 800 °C.
Bacterial filter for measured gas recirculation	Replace every six months. Can be incinerated with little pollution at temperatures of more than 800 °C.
Cooling air filter (set of 3)	Should be cleaned and thoroughly dried or replaced every month. Must be replaced after one year at the latest. Can be disposed of as domestic waste.
Lithium battery for data backup (set of 2)	Must be replaced by professionals after two years. Must be disposed of in accordance with local waste disposal regulations.
Lead gel battery in power pack (set of 2)	Julian should be used in battery mode without a patient at least every 4 weeks. A fully charged battery should keep the workstation operating for at least 30 minutes. If not, get lead gel battery (set of 2) replaced by professionals. Must be replaced by professionals after 2 years. Must be disposed of in accordance with local waste disposal regulations.
Optical measuring set for determining the anaesthetic gas concentration	Must be checked by professionals every six months.
Time-keeper RAM	Must be replaced by professionals after three years. Must be disposed of in accordance with the local waste disposal regulations.
Inspection and maintenance	Must be carried out by professionals every six months

Emergency ventilating bag

Example: Dräger Resutator 2000

- Ready for operation.

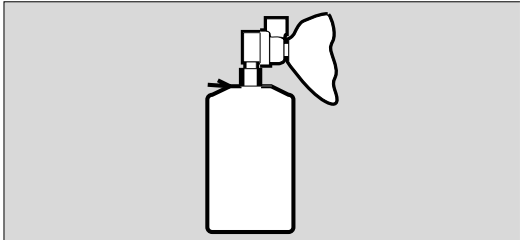

Central gas supply

Gas pressures:

- 1 All pressure gauges in the green zone.

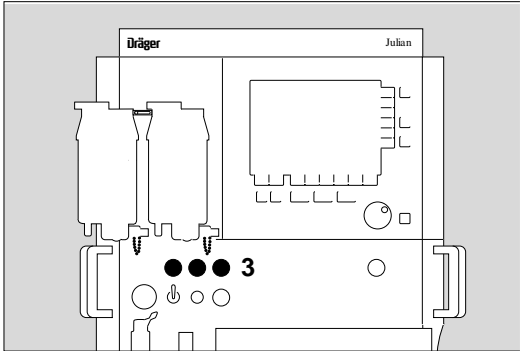

Backup gas cylinders

- 2 Slowly open the cylinder valves.

Check the cylinder pressure gauges:

- 3 O2 pressure greater than 50 bar,
- 4 N2O pressure greater than 30 bar.

- 2 Reclose the cylinder valves.

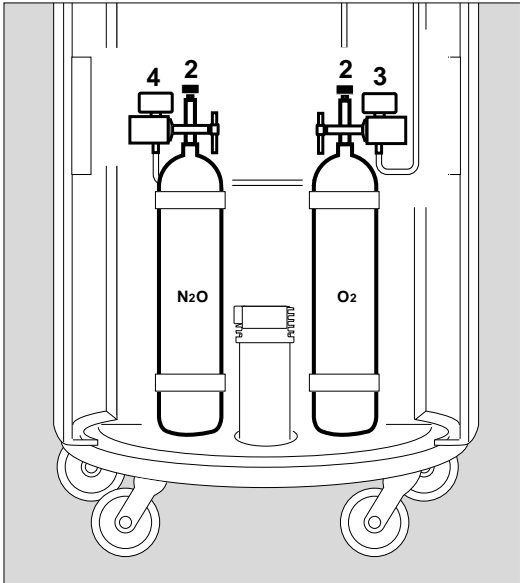

Suction system

- 1 Switch to I.
- 2 Set suction pressure with rotary knob »Vac.«.
- 3 Block the secretion viewing window or kink the suction hose.
- 4 Measure the suction pressure on the pressure gauge.

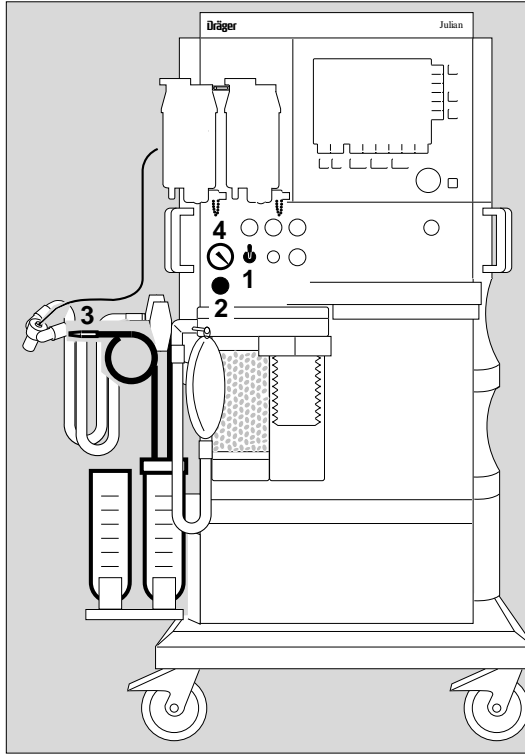

O2 flush

- 5 Press »O2 +« button.
- 6 The breathing bag inflates.
- 7 O2 flows from the Y-piece.

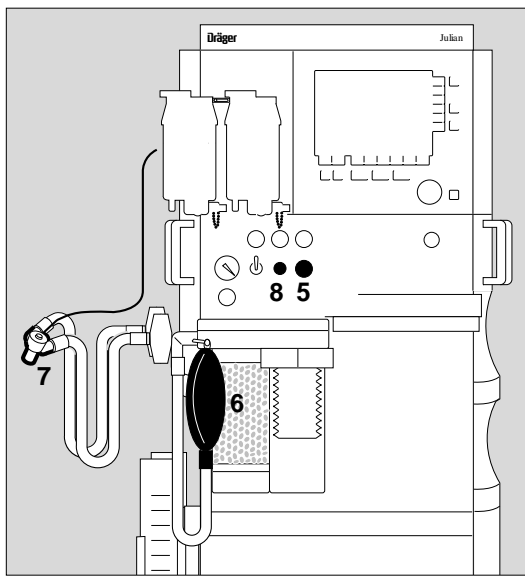

Version with rotary knob for O2 emergency metering

- 8 Turn on rotary knob »Safety O2« for O2 emergency metering.
- 6 The breathing bag inflates.
- 7 O2 flows from the Y-piece.
- 8 Turn off rotary knob »Safety O2« for O2 emergency metering again.

Maintenance Intervals

Contents

- Cleaning the cooling air filters.....117
- Replacing the water separator..... 117
- Replacing the O2 sensor.....117
- Disposing of batteries and O2 sensors..... 118
- Disposing of the used device..... 118

Julian as Wall-mounted Unit

Features

The wall-mounted unit is fixed to the wall and is available in left or right-hand hinged versions.

The supply lines are permanently connected to the wall-mounted unit.

The auxiliary power sockets and the grounding pins for earth leads are located on the left and right sides of the lower half of the unit.

The AGS anaesthetic gas scavenging line is built into the unit.

The on/off switch and display symbols for anaesthetic gas aspiration are located in the lower half of the unit.

The bacterial filter for secretion aspiration is located on the left side of the unit.

The wall-mounted unit must be installed by qualified personnel only.

We recommend DrägerService.

Preparation

Julian can be swung clear of the wall on its hinges to gain access to the back panel.

- 1 Pull the handle to swing the unit about 30° clear of the wall.

- Connect the sampling line for anaesthetic gas measurement to the back panel.

After connecting the sample line:

- Swing the unit back against the wall until it latches into place.
- Pull gently to check that Julian is fixed to the wall.
- Always return the device to the wall position in order to save space and avoid damage.

Anaesthetic gas aspiration

- 2 Switch on = switch pointing upwards, symbol lights up green.

Switch off = switch pointing downwards, symbol unlit.

Operation and Care as per standard Julian model.

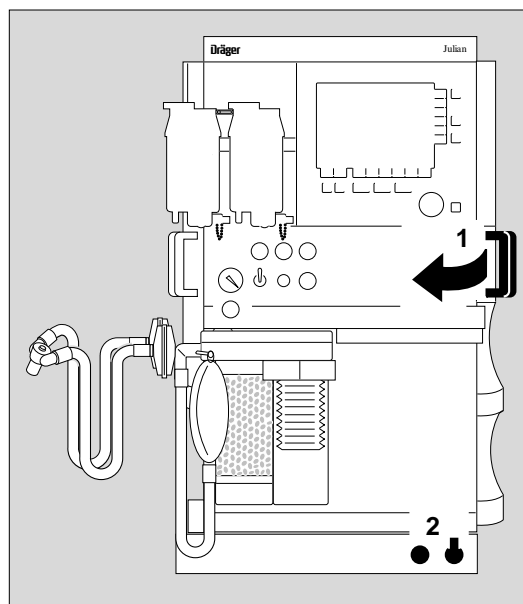

Preparing Julian for the self-test

- Make sure that the breathing system is securely connected.
- 1 Close the Y-piece = plug firmly on to the cone.
 - 2 Ensure that the sample line is connected to the Y-piece and to the water trap on the back of the workstation.

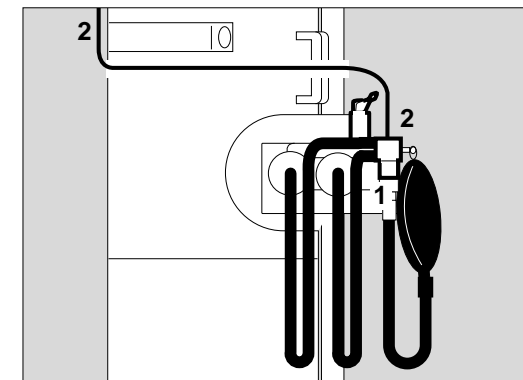

Self-test

If all points on the checklist are OK:

- Confirm = press the rotary knob.
The self-test is started.
The self-test is run automatically and takes 3 to 4 minutes.

Julian carries out the following automatic tests and actions:

Electronics

- Testing and calibration of gas metering bench
- Testing and calibration of O₂ sensor
- Testing of pressure sensor for airway pressure measurement
- Testing the flow sensor
- Testing the battery
- Activating the default settings for alarm limits, monitoring parameters and the default settings of the ventilator and fresh gas settings

Fresh gas mixer

- Testing of gas supply O₂, N₂O, AIR
- Testing of gas inlet valves
- Calibration of pressures sensors in the compressed air supply
- Testing of O₂ emergency metering
- Testing of fresh gas failure monitoring (optional)

Ventilator and breathing system

- Testing and calibration of PEEP/Pmax valves
- Testing of safety valve
- Testing of MAN/AUTO switch-over valve
- Calibration of flow monitoring valve
- Testing of time monitoring valve
- Testing of bellows

System compliance

Julian determines the current system compliance.
 Depending on the breathing hoses used, the system compliance is 5 to 6 mL/bar.

Leakage

Julian determines the current leakage of the breathing system and breathing hoses.
 The system tolerates leaks of up to 150 mL/min.

For leaks of more than 150 mL/min:

- Check the breathing system and repeat the leak test.

Display (example):

A tick (✓) indicates that the relevant test point has been completed successfully.
 The clock symbol ⌚ indicates the test stage is currently in progress.

Malfunctions detected in the self-test and any gas failures are displayed on the screen. Some malfunctions can be accepted by confirming = pressing the rotary knob, for example no AIR supply (AIR FAILURE!!!). Other malfunctions need to be corrected before starting up the workstation, for example no O₂ supply (O₂ FAILURE!!!).

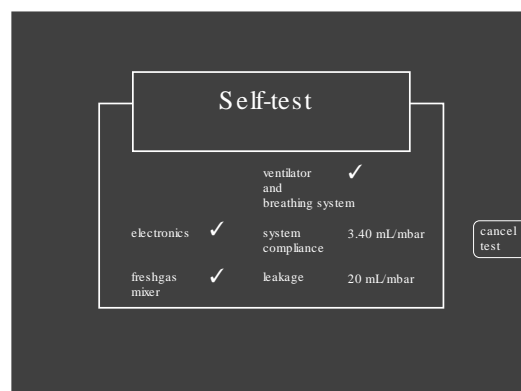

Julian switches to standby after the self-test.

Display:

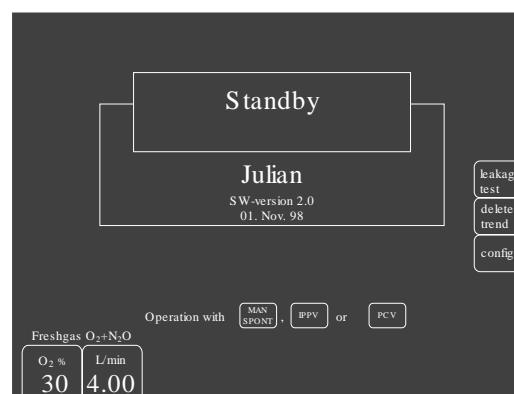

Julian as Wall-mounted Unit

Contents

Features.....	114
Preparation.....	114
Anaesthetic gas aspiration.....	114

Emergency start

This procedure should only be used when there is no time for the self-test!

1 Switch on the workstation.

Version without rotary knob for O2 emergency metering:

After switching on, Julian delivers an O₂ flow of 4 L/min for manual ventilation.

Version with rotary knob for O2 emergency metering:

2 Set rotary knob »Safety-O₂« for O₂ emergency metering to the desired O₂ flow.
Range 0 to 12 L/min.

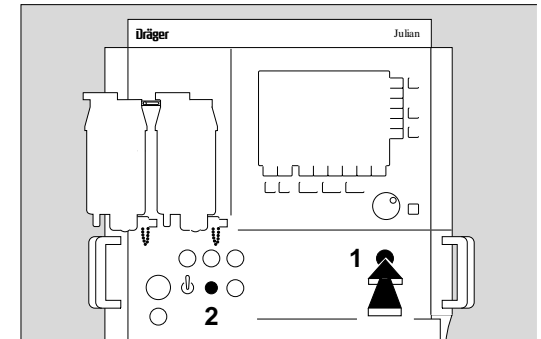

- Wait for the software to be internally loaded and for the electronics to be self-tested.
The checklist appears after about 40 seconds.
- Confirm the checklist: press the rotary knob.
After a few seconds, the »Cancel test« softkey is displayed on the right-hand edge of the screen.

Display:

- Press the softkey »Cancel test«.

The apparatus only runs through a minimal test.

Julian is ready for operation about 1 minute after switching on. Calibration of the O₂ sensor is complete after about 2 minutes.

The leakage and compliance test is not performed.
The accuracy levels specified in the "Technical Data" cannot be guaranteed.

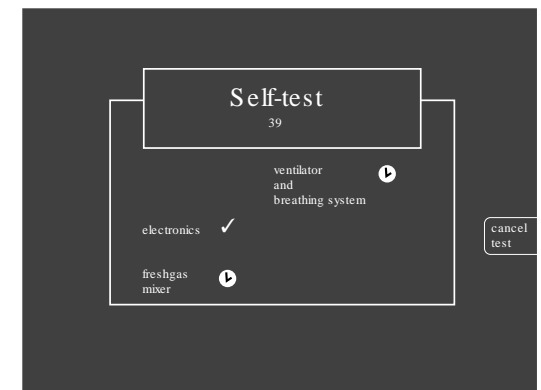

To prevent abuse of this facility, the self-test can only be cancelled 10 times in succession.

The self-test cannot be cancelled the next time that Julian is started and a complete self-test must be run through.

The workstation switches to standby mode after completing the minimal test.

Display (example):

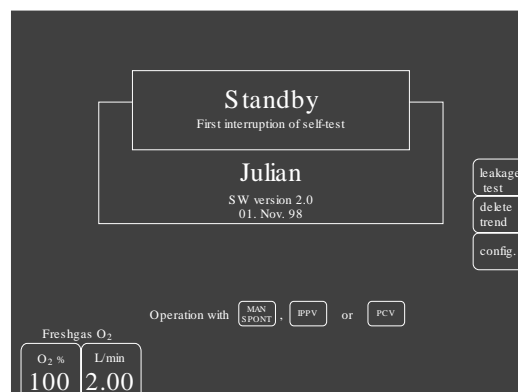

If no key is pressed in standby mode for two minutes, the standby screen is switched off and a screen saver with the Dräger logo is displayed instead.

To switch the standby screen on again:

- Press the rotary knob or any other key.

To start Julian:

Version with rotary knob for O₂ emergency metering:

- Turn rotary knob for O₂ emergency metering to 0.
- Select fresh gas setting and ventilation mode. See »Operation«, page 36 onwards.

Fitting emergency ventilation bag

Example: Dräger Resutator 2000

- Insert the adapter in the bag so that the rubber flange is uniformly located in the groove of the adapter.
- Press the retaining ring together completely with the large eyelet pointing towards the bag and clamp it over the bead on the bag.

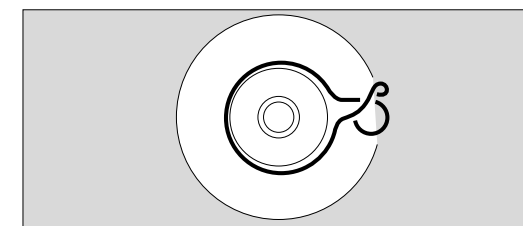

- 1 Place the diaphragm in the bottom part of the valve with the lip facing downwards. Screw the upper part of the valve onto the bottom part.

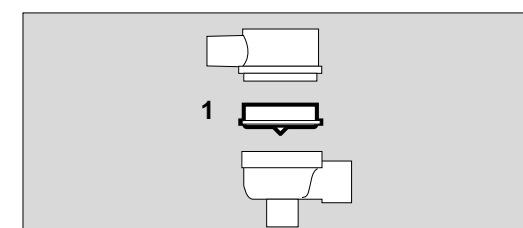

- 2 Plug the patient valve into the bag adapter.

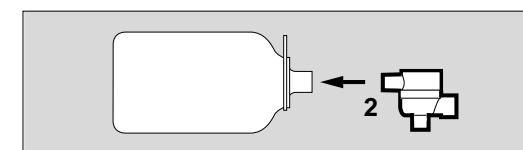

Connecting the anaesthetic gas scavenging system AGS

- 3 Connect the transfer hose to the excess gas connector and to the port of the scavenging system.
 - 4 Connect the suction hose to the port of the scavenging system.
 - 5 Connect the anaesthetic waste gas connector to the suction hose.
 - 6 Ensure that the second port on the scavenging system is sealed with the sealing screw.
- Note the Instructions for Use of the anaesthetic gas scavenging system AGS.

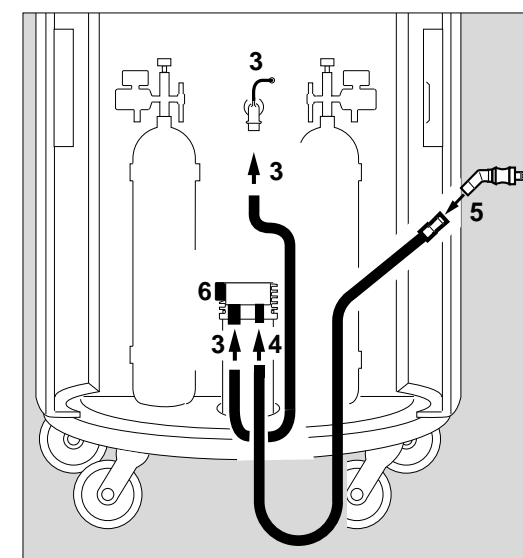

Fitting waste gas connector

- 1 Push waste gas connector into the aperture all the way to the stop, angle downwards.
- 2 Fit hose to connector.

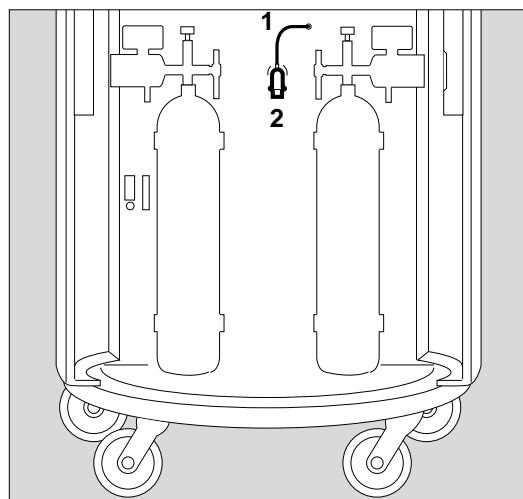

Sample gas scavenging

If the sample gas is not to be recirculated:

- Use hose 11 90 520, connector M 33 151 and sealing cap (optional).
- 2 Connect the hose to the port of the sample gas outlet port.
 - 3 Fit the connector with sleeve to the free end of the hose. Insert the connector in the coupling of the anaesthetic gas scavenging system until it clicks into place.
 - 4 Fit the cap to seal the port.

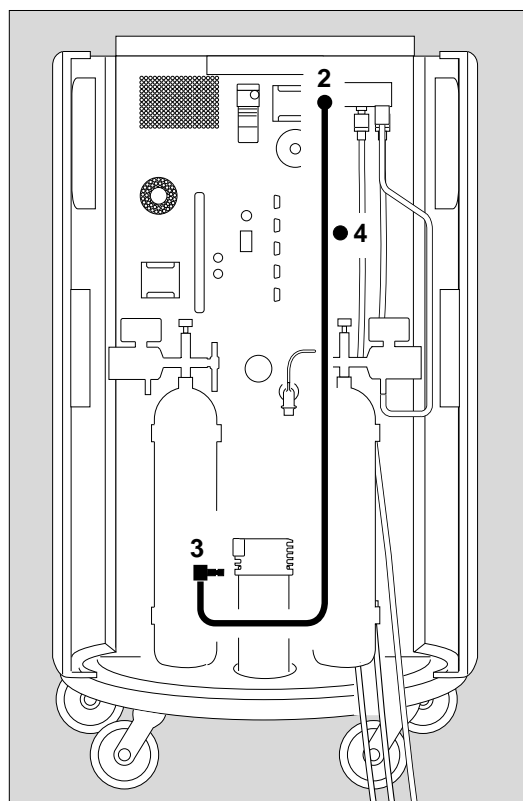

Operation

Contents

Setting the fresh gas concentrations	36
Adjustment ranges.....	36
Selecting the carrier gas.....	36
Setting the O ₂ concentration.....	36
Setting the fresh gas flow.....	37
Selecting the ventilation mode	37
MAN/S PONT ventilation mode.....	37
Manual ventilation.....	37
Spontaneous breathing.....	37
IPPV ventilation mode.....	40
Starting IPPV.....	41
PCV ventilation mode.....	43
Starting PCV.....	44
Setting the Vapor unit	46
Aspirating secretion	46
Changing patients	47
Changing soda lime	47
Leakage test	48
Ventilating children	49
Connecting the breathing hoses.....	49
Using non-rebreathing systems	50
In the event of a power failure	52
In the event of a gas failure	53
In the event of a Major Hardware Fault	53
End of Operation	54

Operation

Setting the fresh gas concentrations

The fresh gas settings are displayed in the **Standby** screen:

- »Fresh gas O₂ + N₂O«
or
»Fresh gas O₂ + AIR«
- O₂ concentration »O₂ % «
- Fresh gas flow »L/min«

The settings correspond to the configurable default values after switching on and after entering standby mode. The fresh gas settings can be modified before selecting the ventilation mode.

Fresh gas does not flow in standby mode. The fresh gas flow is not enabled until a ventilation mode has been started.

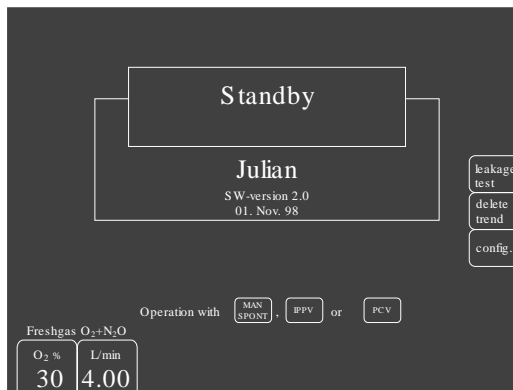

Adjustment ranges and default settings on delivery

Fresh gas parameters	Adjustment range	Default setting on delivery
Carrier gas	AIR or N ₂ O	N ₂ O
O ₂ %	25 to 100	100
Fresh gas flow L/min	0* ; 0,5 to 12	2

Selecting the carrier gas

- 1 Press the »N₂O« or »AIR« hardkey. The yellow LED in the selected key flashes.

- Press the rotary knob to confirm. The yellow LED lights up constantly.

The selected fresh gas components are displayed on the screen.

Setting the O₂ concentration

- 2 Press the softkey »O₂% «.

The key field is highlighted against a white background.

- Set and confirm the O₂ concentration by means of the rotary knob.

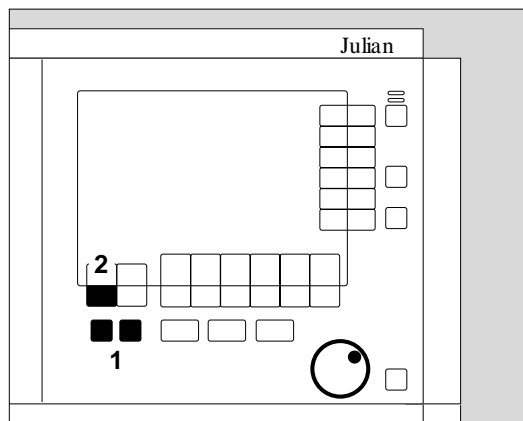

* Only in MAN/SPONT mode

- 1 Press the overflow protection float into the rising pipe until it clicks into place. The float must move freely without falling out.

- 2 Uniformly button the silicone sleeve onto the cover.

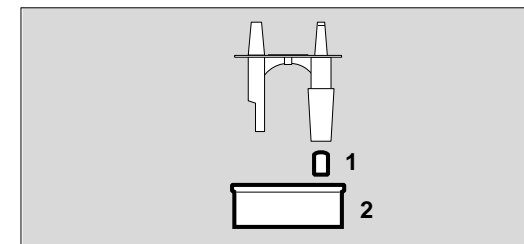

- Connect the bottle cap to the secretion collecting bottles.

- Place the secretion collecting bottle in the inner sleeve and the rinsing bottle in the outer sleeve.

- 3 Fit the vacuum hose to the port on the Julian and to the thin port on the cap.

- 4 Fit the suction hose to the thick port on the cap.

- 5 Fit the secretion inspection window in the suction hose.

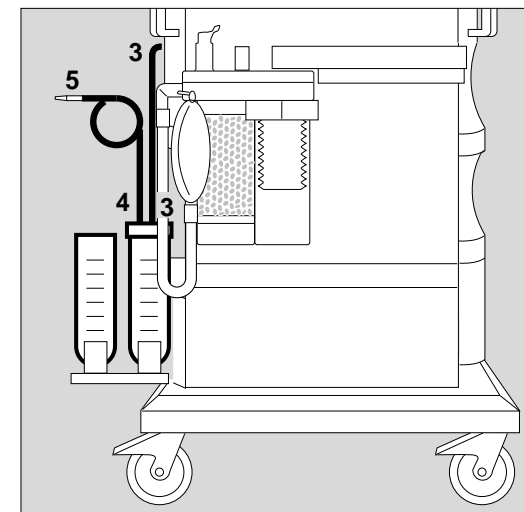

Connecting the measured gas recirculation system

- 6 Fit the short hose to the port of the measured gas outlet.

- 7 Fit the long hose to the port of the recirculation system.

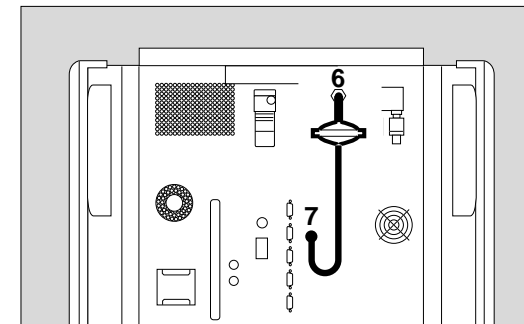

Installing the breathing hoses

- 1 Fit the microbial filters on the inspiration and expiration ports of the breathing system until they audibly engage.
- 2 Connect the 2.3 L breathing bag to the breathing hose with a connecting sleeve. Plug the breathing hose onto the angled connector and hang the breathing bag on the hook.
- 3 Plug the breathing hoses into the microbial filters and connect them to the Y-piece.

Do not use antistatic or conductive breathing hoses!

Fire hazard when using HF electrosurgery.

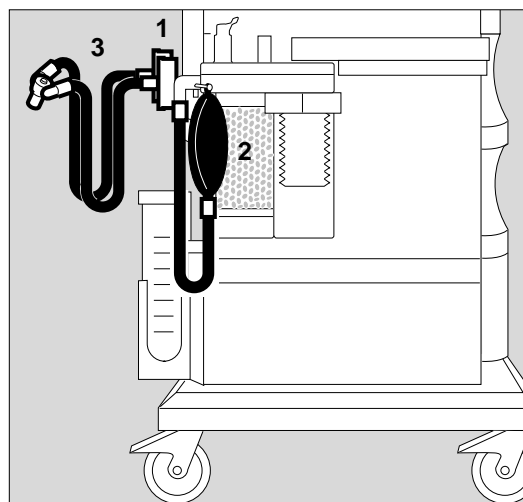

- 4 Fit the water trap container from underneath.

- 5 Screw the sample line onto the Y-piece and water trap.

Only use original sample line. Other lines may change the technical data of the device.

Alcohol and agents containing alcohol must not be allowed to penetrate the sample line!

Alcohol distorts the results of the concentration measurement.

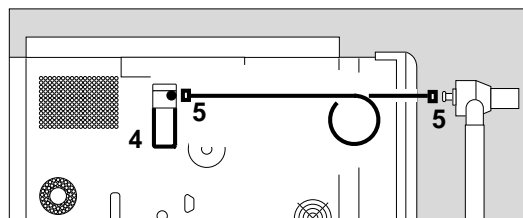

Preparing the suction system

- 6 Plug the bacterial filter into the port on the back panel of the Julian.

- Replace the bacterial filter every two weeks.
- The filter must be disposed of as infectious special waste. It can be incinerated with little pollution at temperatures of more than 800 °C.

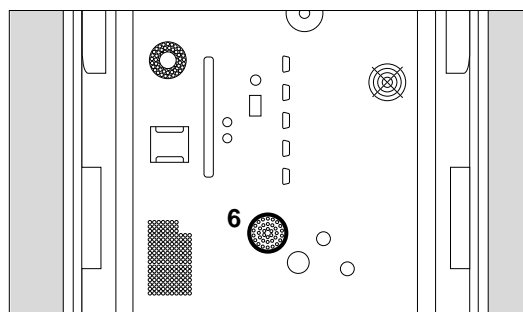

Setting the fresh gas flow

- 1 Press the softkey »L/ min«.

The key field is highlighted against a light background.

- Set and confirm the fresh gas flow by means of the rotary knob.

Julian is fitted with an electronic O₂ minimum dosing system to avoid hypoxic gas mixtures. For fresh gas flow settings below 1 L/min, the O₂ concentration is automatically increased to a value corresponding to an O₂ flow of 250 mL/min. If this control system is activated, the O₂ value is highlighted in addition to the active softkey »L/ min«.

Version with fresh gas failure detection (optional): During operation, Julian checks that the bellows are sufficiently full.

If the message „Fresh gas ? !!“ appears:

- Increase the fresh gas flow

The default settings valid whenever Julian is switched on can also be modified; see "Setting default values" on page 82.

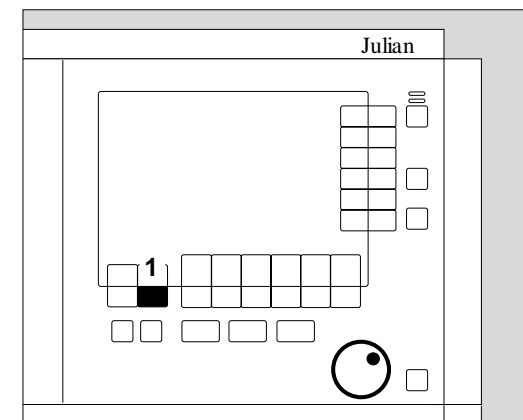

Selecting the ventilation mode

MAN/ SPONT ventilation mode

Choose between manual ventilation **MAN** and spontaneous breathing **SPONT** on the APL pressure-limiting valve.

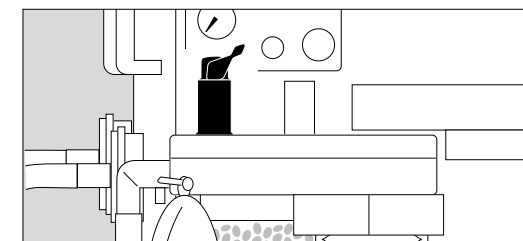

Manual ventilation

- 2 Set the lever of the APL pressure-limiting valve to **MAN**.
- 3 Set the pressure limit = rotate lever.

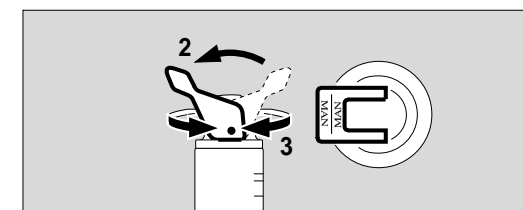

Spontaneous breathing

- 4 Set the lever of the APL pressure-limiting valve to **SPONT**. The valve is open for a free spontaneous breathing stroke regardless of the set pressure limit.

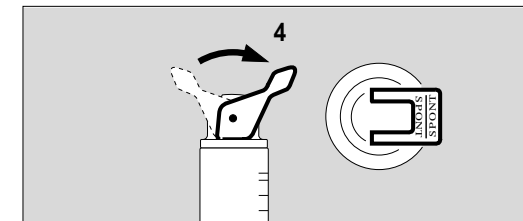

Operation
Selecting the ventilation mode
MAN/SPONT

- 1 Press the »MAN/SPONT« key,
- 2 and confirm with the rotary knob.

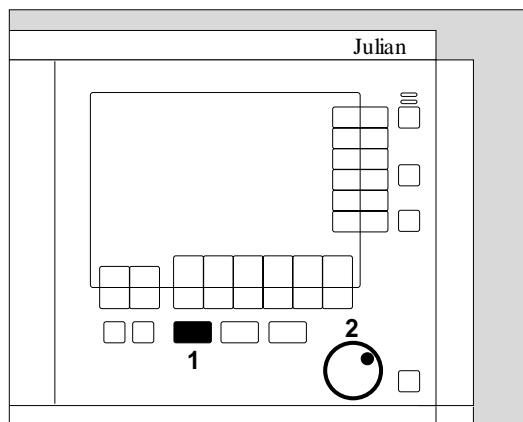

Display (example):

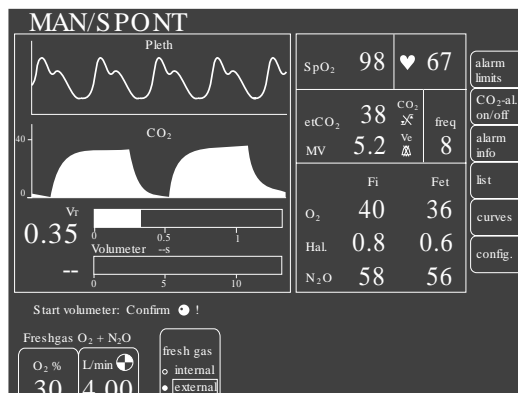

O₂ flush

– For flushing and rapidly filling the breathing system and breathing bag with O₂ while bypassing the Vapor unit.

- 3 Press the »O₂ +« button. O₂ flows into the breathing system without anaesthetic gas as long as the button is held down.

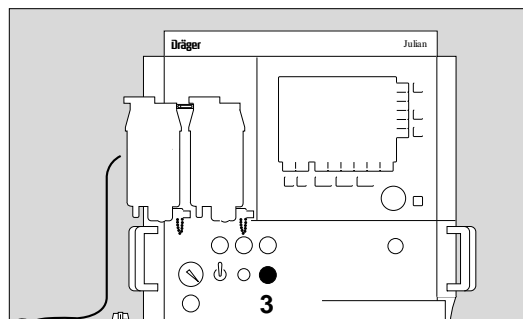

Installing the bellows

- Hold the breathing system from above to prevent it dropping out and
- 1 uniformly slide the tightly compressed bellows onto the connector.
 - 2 Insert the container in the breathing system from below and turn it clockwise as far as possible.

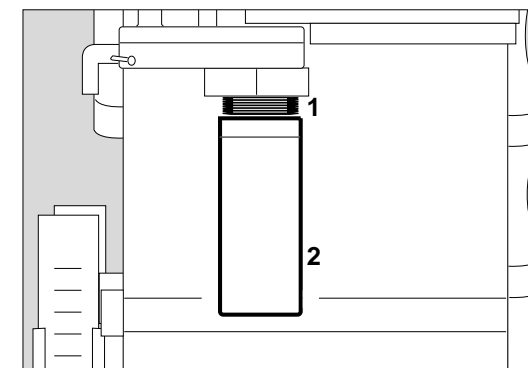

Filling and installing the absorber

- 3 Push the insert fully into the absorber.
- Fill the absorber with fresh soda lime – up to the MAX mark. Only use Drägerorb 800!

If the breathing system is to remain unused during the next 24 hours:

- Only fill with soda lime immediately before use! Soda lime dries out when exposed to ambient air and sun for a longer period of time. This reduces the CO₂ absorption capacity and the effectiveness of the indicator.

- 4 Insert the absorber in the breathing system from below and turn clockwise as far as possible.

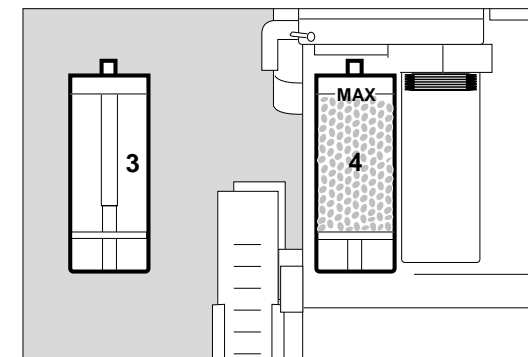

- 5 Slot in the breathing system – as far as possible.
- 6 Fold down the writing top.

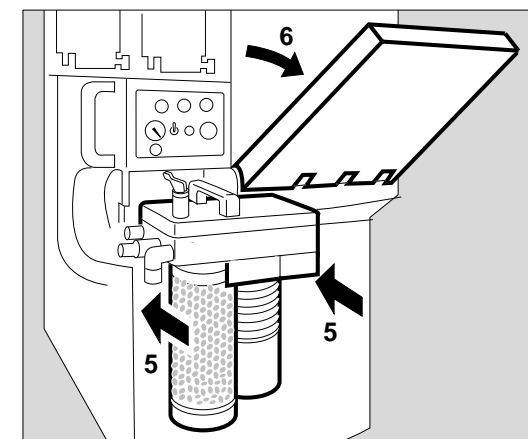

Assembling

Installing the breathing system

- 1 Place the bottom section on a flat surface.
- 2 Fit the valve plate on the bottom section.
- 3 Insert both valve discs.
- 4 Tightly fit the cover.
- 5 Tighten all five sealing screws a quarter-turn.

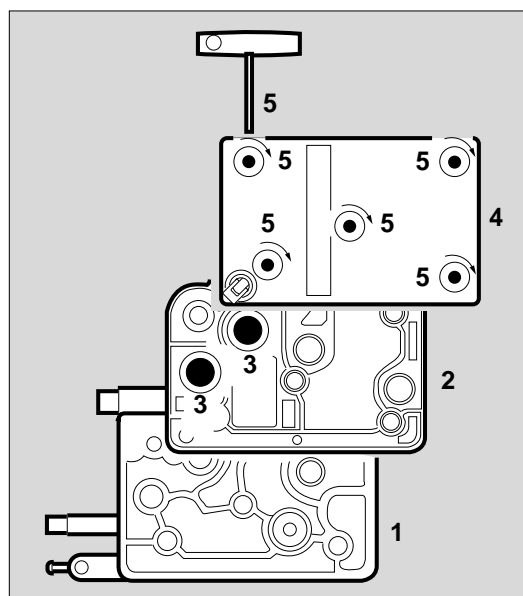

- 6 Hang the breathing system into the slot-in unit.

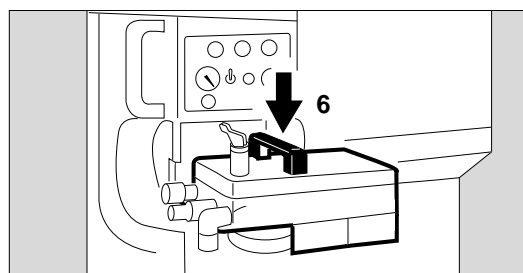

Inserting the flow sensor

- 7 Insert the flow sensor with the electric connection in the slot.
 - 8 Push in the expiration port with the nose of the port in the slot.
- Tighten the knurled nut by hand.

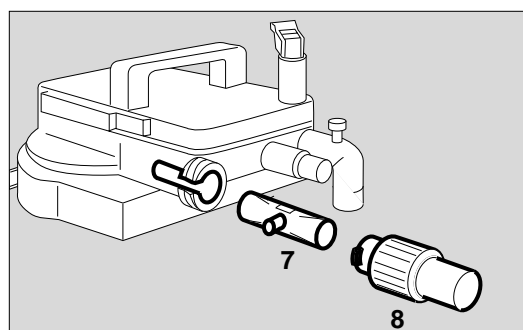

Certain alarms are automatically switched off in MAN/SPONT ventilation mode in order to avoid artefacts. The deactivated alarms are identified by the grey background in the table.

Alarm limits	in MAN/SPONT mode	Default setting on delivery
SpO ₂ ✓	ON ON	-- 92
Pulse ♥ ✓	ON ON	120 50
etCO ₂ ✓	ON ON	50 (mmHg) --
FiCO ₂ ✓	OFF	
MV ✓	OFF OFF	-- --
FiO ₂ ✓	OFF ON	-- 20
Fi Hal. ✓	ON OFF	1.5 --
Fi Iso. ✓	ON OFF	2.3 --
Fi Enf. ✓	ON OFF	3.4 --
Fi Des. ✓	ON OFF	12.0 --
Fi Sev. ✓	ON OFF	3.4 --
PAW ✓	ON OFF	40 --
Apnoea pressure	OFF	
Apnoea flow	OFF	
Apnoea CO ₂	ON	activated after 60 seconds

--: The default setting on delivery is outside the monitoring range and the corresponding alarm limit is switched off.

To set the values of the alarm limits during operation see page 60.

To set the default alarm limits see page 86.

Care list for Julian anaesthetic workstation

Only applies for non-infectious patients.

When used with infectious patients, all parts in contact with breathing gas must additionally be sterilized after disinfection and cleaning.

What Components which can be conditioned	How often Conditioning intervals ¹⁾		
	Filter on Y-piece	Filter on inspiration and expiration port	Without filter
Julian workstation	Front daily, other surfaces weekly		
Vapor 19.3 / Devapor unit	Daily		
Power cable, compressed gas hoses, equipotential bonding lead	Monthly		
Breathing bag with twin connector and hose	Daily	Daily	Per patient
Breathing hoses	Daily	Per patient	Per patient
Bellows	Weekly	Weekly	Daily
Y-piece	Daily	Per patient	Per patient
Cover of breathing system with APL valve	Weekly	Weekly	Daily
Middle and bottom part of breathing system	Weekly	Weekly	Daily
Container of bellows	Weekly	Weekly	Weekly
Valve discs (use a cassette)	Weekly	Weekly	Daily
Expiration port	Weekly	Weekly	Daily
Absorber and insert	Weekly	Weekly	Daily
Water trap (monitoring)	Daily	Daily	Daily
Microbial filter 654 St	—	Daily	—
Filter of the measured gas recirculation system	Weekly	Weekly	Weekly
Flow sensor	Weekly	Weekly	Daily
AGS housing	Weekly		
AGS flow tube (without filter)	Weekly		
Container for AGS buffer volume	Weekly		
AGS transfer hose	Weekly		
Scavenging hose with connector	Monthly		
Waste gas connector with tube	Weekly		
Hose of sample gas return or hose of sample gas scavenging	Weekly		
Emergency breathing bag, its diaphragm, upper and lower valve parts (Dräger Resutator 2000)	After each use		
Silicone sleeve of secretion collecting bottle and rinsing bottle, their lid with float, suction hose and inspection window	As required, but at least daily		
	¹⁾ The conditioning intervals depend on the use and position of the filters. The table is merely intended as a rough guide. The instructions of the hospital's hygiene officer shall prevail!		

Starting IPPV

- 1 Press the »IPPV« hardkey
- 2 and confirm with the rotary knob.

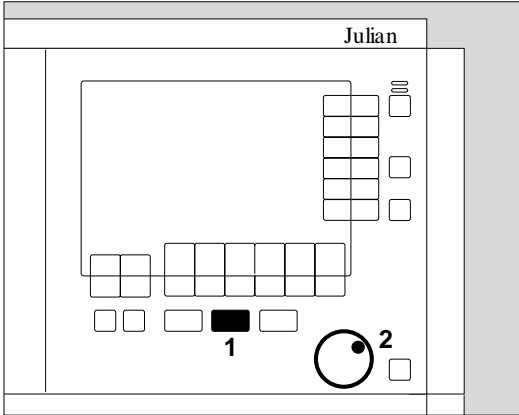

Display (example):

The preset ventilation parameters are displayed on the screen.

The symbol  rotates in the softkey »L/min« to indicate that fresh gas is flowing.

If a change in ventilation parameters is required:

- Press the corresponding softkey. Set and confirm the ventilation parameter with the rotary knob.

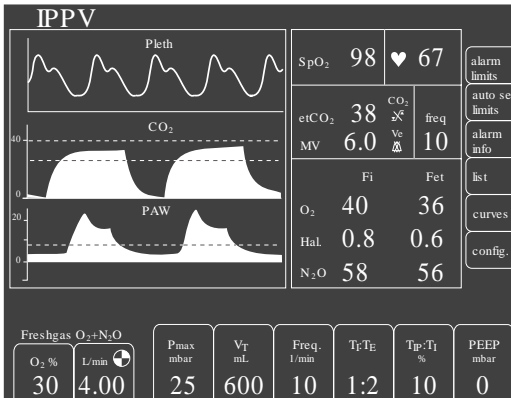

Alarms effective in IPPV mode

Alarm limits	In IPPV mode	Default setting on delivery
SpO ₂ ✓ [▲]	ON ON	-- 92
Pulse ♥ ✓ [▲]	ON ON	120 50
etCO ₂ ✓ [▲]	ON ON	50 (mmHg) --
FiCO ₂ ✓ [▲]	ON	Fixed upper alarm limit 5 mmHg
MV ✓ [▲]	ON ON	-- 3.0
FiO ₂ ✓ [▲]	ON ON	-- 20
Fi Hal. ✓ [▲]	ON ON	1.5 --
Fi Iso. ✓ [▲]	ON ON	2.3 --
Fi Enf. ✓ [▲]	ON ON	3.4 --
Fi Des. ✓ [▲]	ON ON	12.0 --
Fi Sev. ✓ [▲]	ON ON	3.4 --
PAW ✓ [▲]	ON ON	40 8
Apnoea pressure	ON	Active after 15 seconds
Apnoea flow	ON	Active after 15 seconds
Apnoea CO ₂	ON	Active after 30 seconds

-- : The default setting on delivery is outside the monitoring range and the corresponding alarm limit is switched off.

To set the values of the alarm limits during operation see page 60.

To set the default alarm limits see page 86.

Microbial filter 654 St

- Wipe the surface with a disposable cloth.

Do not clean with solvents such as naphtha, alcohol or ether.

Do not clean the filter in cleaning and disinfecting machines.

Do not immerse the filter in disinfectant solution.

- Sterilize the filter at max. 134 °C in a hot steam sterilizer.
Do not use ethylene oxide sterilization!
Do not sterilize when connected!
- Mark each sterilization in the corresponding field on the filter housing (e.g. with a water-resistant pen).

The filter can be sterilized up to 24 times.

The filter must be discarded:

- if the pressure rise in the resistance test is greater than 2 mbar.
- after being sterilized 24 times at the most.

- The filter must be sterilized once more in hot steam at 134 °C after use and can then be disposed of as plastic with ordinary domestic waste.

Note the hygiene regulations of the hospital.

All the components are listed in the care list for Juian on pages 104 and 105, together with the corresponding intervals and appropriate means.

Disinfecting / cleaning / sterilizing

Only products from the list of surface disinfectants may be used for disinfection. To ensure material compatibility, products based on the following agents may be used:

- Aldehydes
- Alcohols
- Quaternary ammonium compounds.

The following products are not suitable:

- Compounds containing alkylamines
- Compounds containing phenols
- Halogen-releasing compounds
- Strong organic acids
- Oxygen-releasing compounds.

Users in the Federal Republic of Germany are advised to use disinfectants specified in the current list published by the German Society for Hygiene and Microbiology (DGHM). The DGHM list also specifies the active agent of each disinfectant.

Users in countries in which the DGHM list is not available are advised to use the agents mentioned above.

Alcohols and agents containing alcohol must not be allowed to seep into the sample line!

Alcohol can distort the measurement results.

Breathing system

All parts of the breathing system, valve discs, bellows, bellows container, Y-piece, breathing hoses, water trap containers, breathing bag, parts of the absorber and Resutator 2000, parts of the secretion aspirator and parts of the anaesthetic gas scavenging system

- Disinfect in hot liquid disinfectant – in a disinfecting machine at 93 °C for 10 minutes.
Only use cleaning agent, no alkaline or chlorine-releasing substances – risk of corrosion!

All parts of the breathing system (except the flow sensor!), Y-piece, breathing hoses, water trap containers, breathing bag, parts of the absorber, parts of the secretion aspirator and parts of the anaesthetic gas scavenging system

- can be sterilized in hot steam at 134 °C.

Surfaces of Julian, compressed gas hoses, cables and Vapor 19.3 / Vapor 2000 / Devapor

The surface of the apparatus must not be treated with agents containing alcohol.

- Wipe off impurities with a damp disposable cloth.
- Disinfect with a wipe-on disinfectant, e.g. Buraton 10 F (made by Schülke & Mayr GmbH). Note the manufacturer's Instructions for Use. Do not allow any liquids to enter openings in the apparatus.

Flow-Sensor

- Disinfect for approx. 1 hour in 70 % ethanol solution. Leave the sensor to dry in air for at least 30 minutes, otherwise the remaining alcohol can damage the sensor when calibrated. The flow sensor cannot be autoclaved.
- The flow sensor can be reused as long as it can be calibrated successfully.
- The flow sensor must be disposed of as infectious special waste. It can be incinerated with little pollution at temperatures of more than 800 °C.

PCV ventilation mode

PCV = Pressure Controlled Ventilation

In pressure controlled ventilation mode, the applied tidal volume depends on the ventilation parameters Pmax, insp. Flow, insp. Time, PEEP and the lung compliance. Changes in ventilation parameters or lung compliance influence the tidal volume and the MV minute volume must therefore be monitored constantly.

Presetting ventilation parameters for PCV

- 1 Press »PCV« its LED flashes.
- The five ventilation parameters for PCV appear on the screen with the default settings.
- 2 Press the softkey of the relevant ventilation parameter.
- 3 Set and confirm the ventilation parameter with the rotary knob.

Display (example):

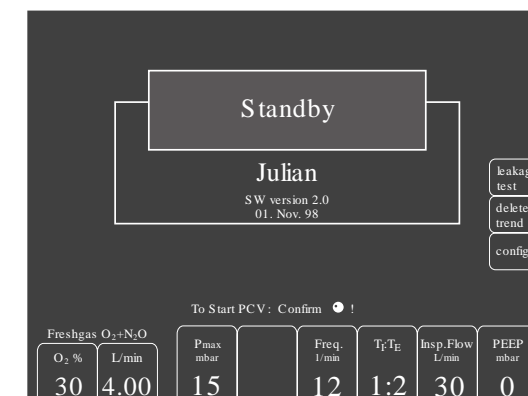
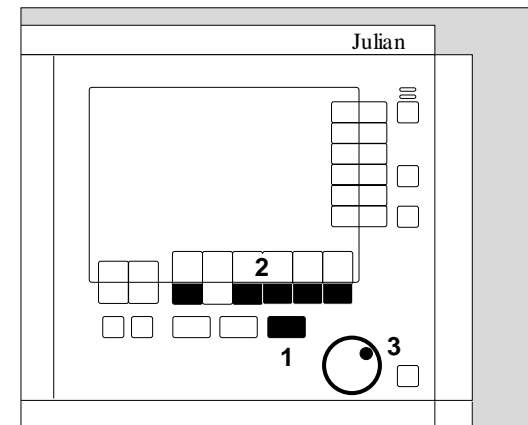

Adjustment ranges and default settings on delivery

Ventilation parameter	Adjustment range	Default setting on delivery*
Pressure limit Pmax [mbar]	(PEEP+1) to 70	15
Frequency Freq. [1/min]	6 to 60	12
Insp./Exp. ratio [Ti : Te]	2: 1, 1: 1, 1: 2, 1: 3, 1: 4	1 : 2
Insp. flow [L/min]	5 to 50 (75**)	30
PEEP [mbar]	0 to 20	0

When ventilating infants weighing less than 20 kg:

- Use the paediatric hose set; see page 49 "Ventilating children".

* The default settings can be set specifically for each hospital, see page 82.

** Can be set by DrägerService.

Starting PCV

- 1 Press »PCV«.
- 2 Confirm by pressing the rotary knob.

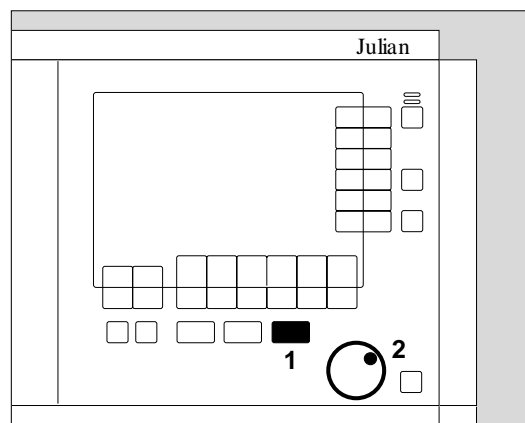

Display (example):

The preset ventilation parameters appear on the screen.

Fresh gas flows, as indicated by the rotating symbol in the softkey »L/min«.

If a change in ventilation parameters is required:

- Press the relevant softkey. Set and confirm the ventilation parameter with the rotary knob.

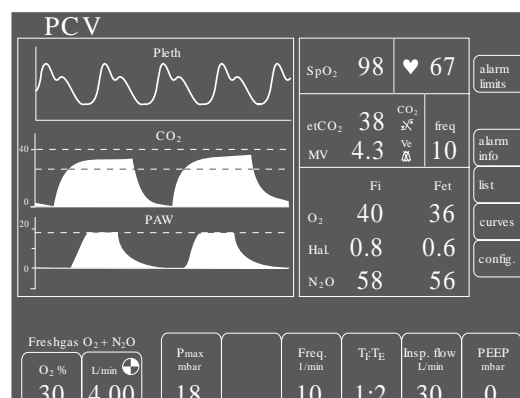

Removing waste gas connector

- 1 Pull hose off connector.
- 2 Remove waste gas connector completely.

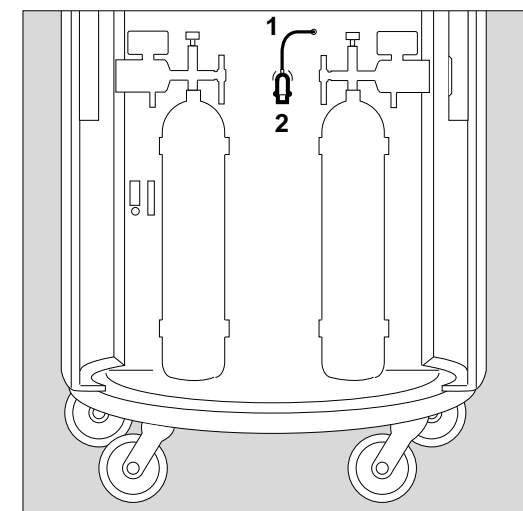

Dismantling emergency ventilation bag

Example: Dräger Resutator 2000

- Disconnect the mask or ventilation tube from the patient valve.
- Pull the patient valve out of the bag.
- Compress the retaining ring on the bag completely and remove it.
- Pull the adapter out of the bag.

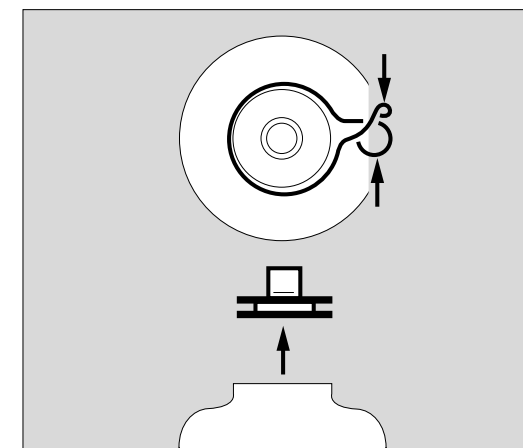

- Unscrew the bottom part of the valve and remove the diaphragm.
The small diaphragm must remain in the upper part of the valve
- Prepare the individual parts for disinfection and cleaning in a washing machine.

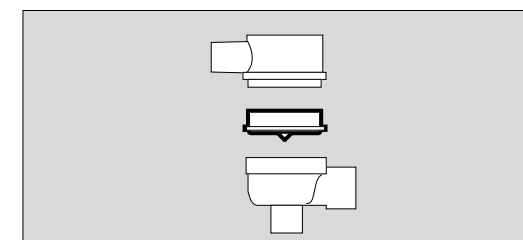

Opening the breathing system

– Weekly

1 Loosen the five sealing screws a quarter-turn with the key supplied.

● Remove the cover.

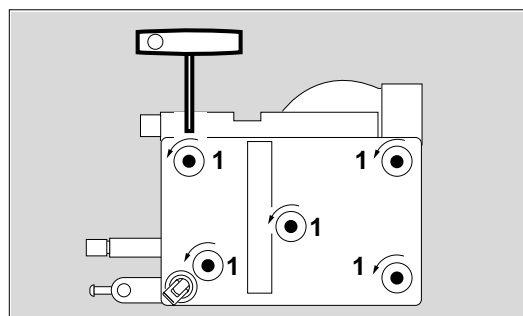

2 Remove the two valve discs.

● Lift off the metal valve plate.

● Keep the valve discs in a cassette to protect them against damage and prepare them for disinfection and cleaning in a washing machine.

● Prepare the housing parts for disinfection and cleaning in a washing machine.

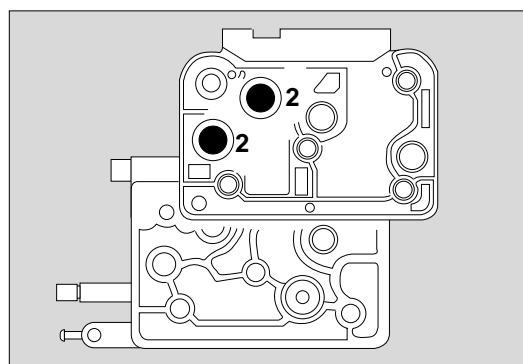

Dismantle the anaesthetic gas scavenging system AGS

3 Remove the scavenging hose.

4 Remove the transfer hose.

5 Remove the anaesthetic gas scavenging system.

● Prepare the individual parts for disinfection and cleaning in a washing machine.

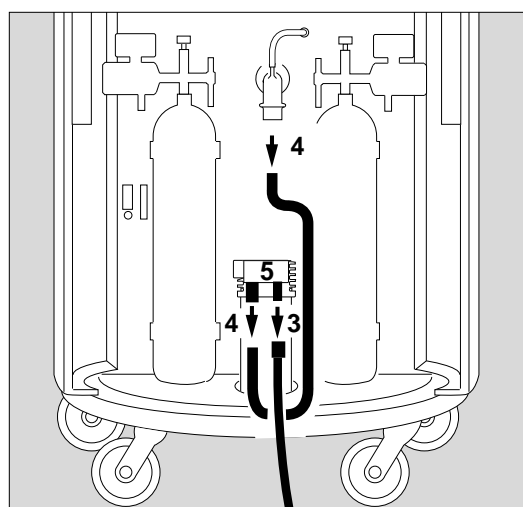

Alarms effective in PCV mode

Alarm limits	In PCV mode	Default setting on delivery
SpO ₂ ✓/✗	ON ON	-- 92
Pulse ♥ ✓/✗	ON ON	120 50
etCO ₂ ✓/✗	ON ON	50 (mmHg) --
FiCO ₂ ✓/✗	ON	Fixed upper alarm limit 5 mmHg
MV ✓/✗	ON ON	-- 3.0
FiO ₂ ✓/✗	ON ON	-- 20
Fi HaI. ✓/✗	ON ON	1.5 --
Fi Iso. ✓/✗	ON ON	2.3 --
Fi Enf. ✓/✗	ON ON	3.4 --
Fi Des. ✓/✗	ON ON	12.0 --
Fi Sev. ✓/✗	ON ON	3.4 --
PAW ✓/✗	ON ON	40 8
Apnoea pressure	ON	Active after 15 seconds
Apnoea flow	ON	Active after 15 seconds
Apnoea CO ₂	ON	Active after 30 seconds

--: The default setting on delivery is outside the monitoring range and the corresponding alarm limit is switched off.

To set the values of the alarm limits during operation see page 60.

To set the default alarm limits see page 86.

Setting the Vapor unit

- 1 Lock the unused Vapor unit
 = push lever fully in the direction of the unused Vapor
 (example: left-hand Vapor locked).
- 2 Press the O button and
- 3 set the handwheel to the required anaesthetic agent concentration.

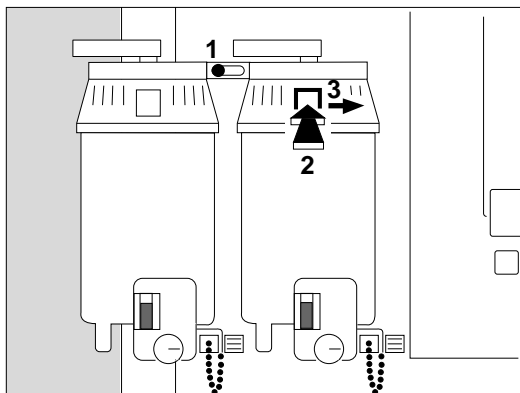

Aspirating secretion

- Swing the bottles forwards.
- 1 Set the switch to I.
 - 2 Seal the "fingertip" or kink the suction hose and
 - 3 Set the appropriate suction pressure for the patient with the rotary knob »Vac.« and
 - 4 check on the pressure gauge.

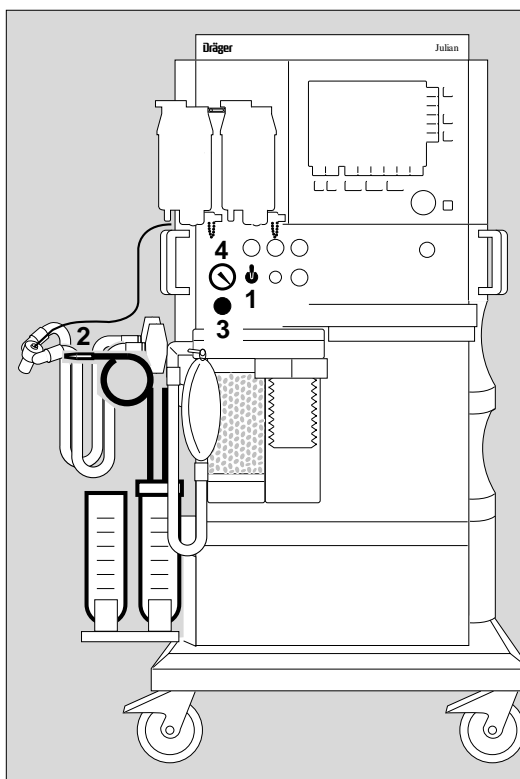

Observe the hygiene regulations of the hospital!

After aspirating

- Rinse the suction hose with the water purifier.
- 1 Set the switch to 0.

Dismantling the breathing system

- 7 Fold up the writing top.
- 8 Pull the catch and at the same time pull out the slot-in module.
- 9 Hold breathing system by the handle and pull upwards to remove.

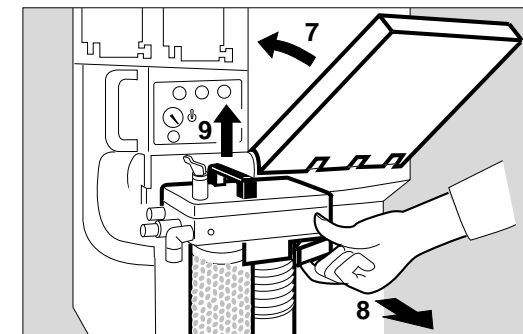

Removing the flow sensor

- 1 Unscrew the expiration port.
- 2 Remove the flow sensor.

The flow sensor cannot be disinfected / cleaned in a washing machine, nor can it be sterilized in high-temperature steam.

- The flow sensor must be disinfected in 70 % ethanol solution for approx. 1 hour. Leave the sensor to dry in air for at least 30 minutes, otherwise the remaining alcohol can damage the sensor when calibrated.
- The flow sensor can be reused as long as it can be calibrated successfully.

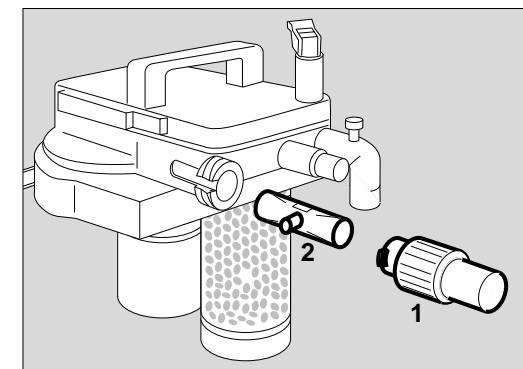

Removing the absorber and bellows

- 3 Turn the absorber counterclockwise and pull it downwards.
- Empty the soda lime; it can be disposed of with ordinary domestic waste.
- 4 Remove the insert from the absorber.
- 5 Turn the container of the bellows counterclockwise and pull it downwards.
- 6 Remove the bellows.
- Prepare the absorber, container of the bellows and the bellows for disinfection and cleaning in a washing machine.

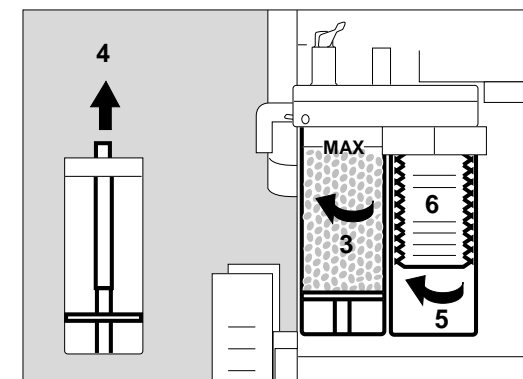

Dismantling the suction system

- 1 Remove the suction hose and vacuum hose.
- 2 Grip the silicone sleeve of the bottle cap and pull it off.
- 3 Remove the secretion collecting bottle and flushing bottle from the bracket and empty them.
Note the hygiene regulations of the hospital.

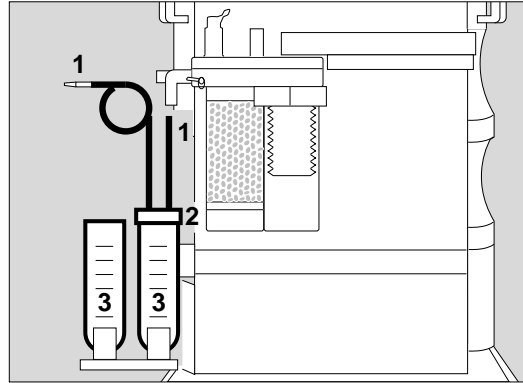

- 4 Remove the silicone sleeve from the lid of the secretion collecting bottle.
- 5 Remove the overflow protection float from the rising pipe.
Store the parts together for disinfection and cleaning in a washing machine.

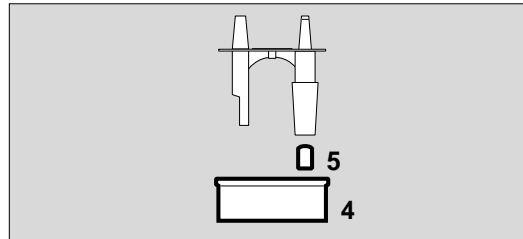

- 6 Replace the bacterial filter in the back panel of the Julian – if soaked through or if contamination is suspected.
The filter must be replaced at the latest every two weeks.
- The bacterial filter must be disposed of as infectious special waste. It can be incinerated with little pollution at temperatures of more than 800 °C.

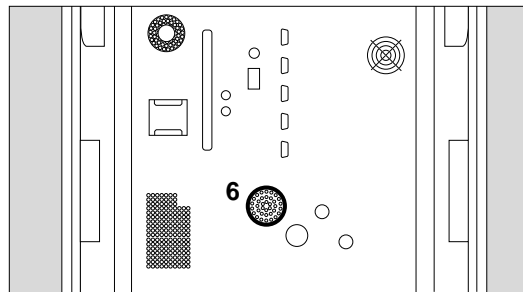

Changing patients

To switch Julian to standby:

- Press the Standby key  and confirm with the rotary knob.

The functions of the workstation are switched off.
The set alarm limits are cancelled and the default alarm settings are valid again.

The default settings are loaded for dosing anaesthetic gas and for the ventilation parameters.

If the ventilation hoses have been changed:

- Perform a leakage test, page 48.

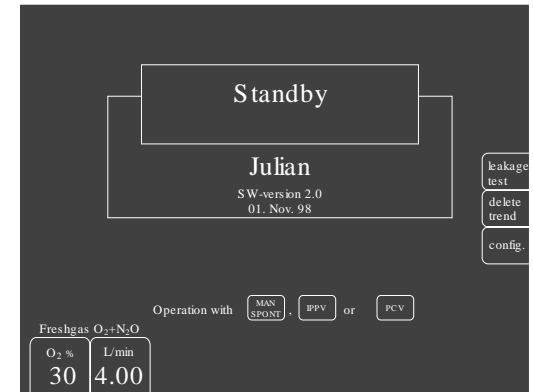

Changing soda lime

- If 2/3 of the absorber charge has turned violet.
- If the inspiratory CO₂ concentration FiCO₂ equals 5 mmHg or more.

- Press the Standby key  and confirm by pressing the rotary knob.

- 1 Raise the writing top.
- 2 Pull the catch and draw out the breathing system at the same time.

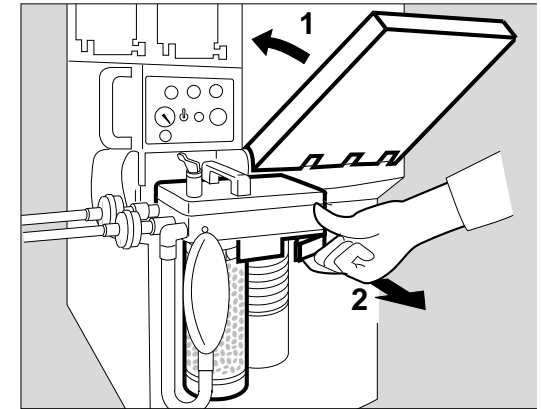

- 3 Turn the absorber counterclockwise and pull it out downwards.
- Drain the used soda lime and dispose of with domestic waste.
 - Fill the absorber with fresh soda lime up to the MAX mark.
 - Fit the absorber to the breathing system from below and turn it clockwise as far as it will go.
 - Push the breathing system inwards until it clicks into place.
 - Fold down the writing top.

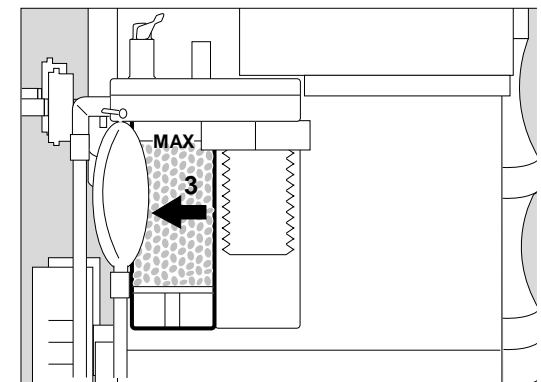

Leakage test

Must not be performed when a patient is connected to the workstation!

- When the soda lime has been changed or
- when the breathing hoses have been changed.

1 Close the Y-piece = place firmly on the cone.

2 Ensure that the sample line is connected to the Y-piece and to the water trap at the back of the workstation.

- Press the softkey »leakage«.

Julian performs the leakage test for IPPV/PCV, duration approx. 30 seconds.

The breathing bag and its hose are not included in the test.

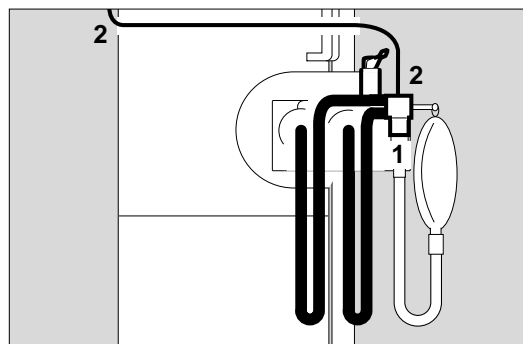

Display:

After the test has been successfully completed, the clock symbol disappears and Julian displays the values for leakage and system compliance for a few seconds. The results of the leakage test are continually displayed on the data screen.

To return to the standby screen:

- Press the rotary knob.

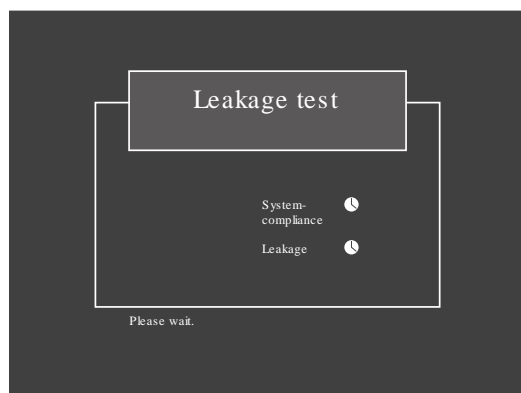

- Do not damage the breathing hoses!
Always hold the hoses by the connection sleeve and not by the spiral ribbing when removing and connecting the breathing hoses, otherwise the spiral ribbing may be torn off the sleeve.
Breathing hoses with damaged spiral ribbing can easily be kinked and interrupt ventilation!
Always check the breathing hoses for damage prior to use.
Damaged breathing hoses must not be used.

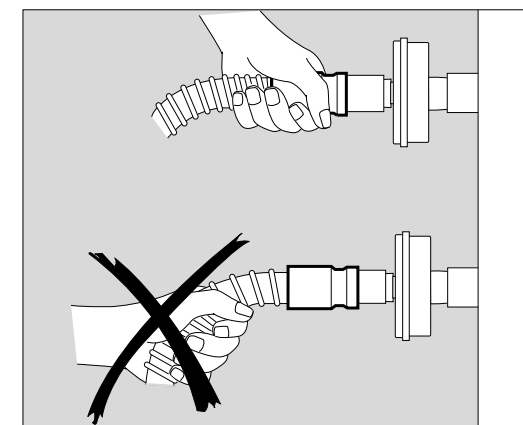

Removing microbial filters

On the sleeve of the microbial filter:

- Press together the surfaces marked »PRESS« and pull the filter off the connection at the same time. Do not use force, otherwise the sleeve may be damaged.
- Prepare the microbial filter for conditioning in accordance with the separate Instructions for Use.

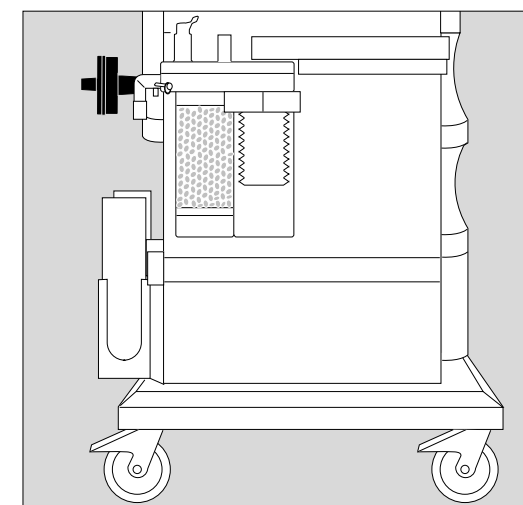

Care

Dismantling components

Dismantling sample line

- Unscrew the sample line from the Y-piece and water trap on the back of the unit.
The sample line is not reusable and can be disposed of with ordinary domestic waste.

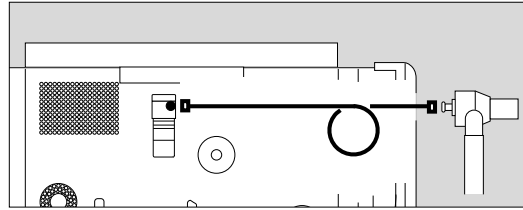

Removing water trap container

- Pull the container of the water trap down and off, and empty it.
Note the hygiene regulations of the hospital!
- Prepare the container of the water trap for disinfection and cleaning in a washing machine.

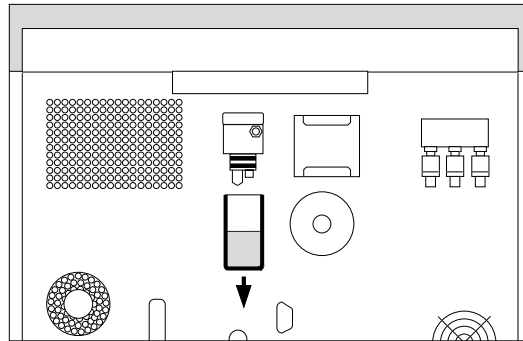

When using the "Waterlock" water trap

- See separate Instructions for Use.

Removing breathing hoses

- Remove the breathing hoses and breathing bag.
- Dismantle Y-piece and connector.
- Prepare the breathing hoses, breathing bag and Y-piece for disinfection and cleaning in a washing machine.

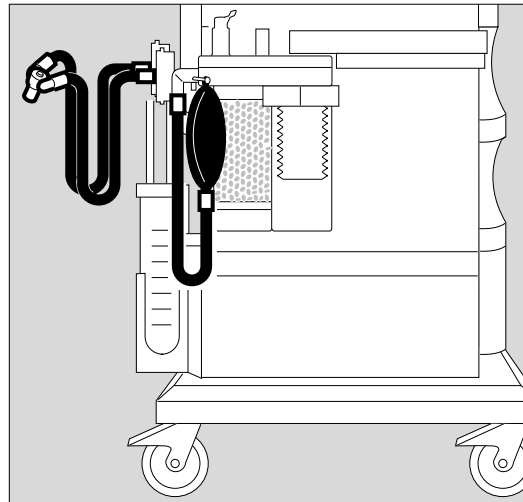

Ventilating children

For tidal volumes V_T of less than 200 mL:

- Use paediatric hoses.

Connecting the breathing hoses

- 1 Use Y-piece with connection for sample line.
- The inspiratory and expiratory microbial filter 654 St should not be used – this reduces the system compliance.
- 2 Connect 0.5 L breathing bag with socket to the breathing hose with the large connection sleeves. Slip the breathing hose over the angled socket. Hang the 0.5 L breathing bag onto the hook.
- 3 Slip the breathing hoses with the large sleeves onto the inspiratory and expiratory sockets and connect the small sleeves to the Y-piece.

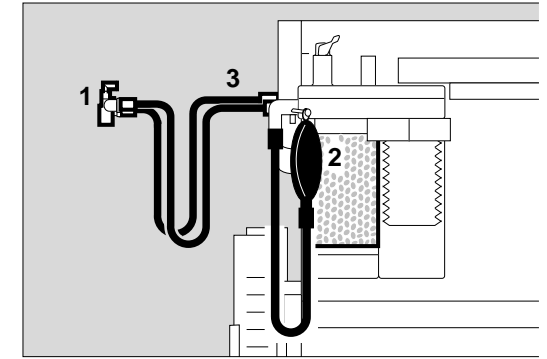

- 4 Connect the sample line to the Y-piece and water trap.
- Set the sample rate to 200 mL/min, page 84.

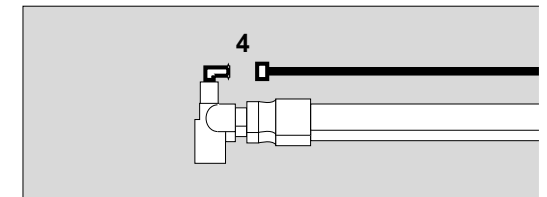

If the measured gas is not recirculated:

- Increase the tidal volume V_T in accordance with the sample rate.

Volumeter function:

- Select »Child« scale, page 67.

To determine system compliance and leakage:

- 5 Firmly connect the Y-piece to the cone.
- Determine the system compliance and leakage, see „Leakage test“ on page 48.
Set a correspondingly higher tidal volume V_T in accordance with the airway pressure PAW.
- Use PCV or IPPV ventilation mode.

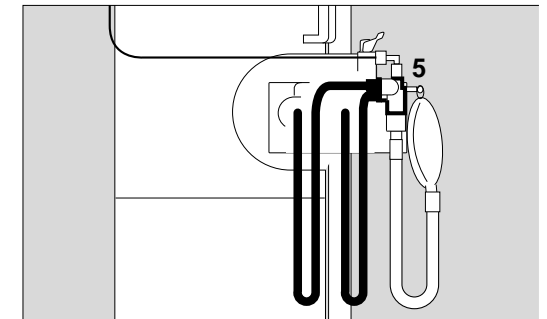

Using non-rebreathing systems

Example: Bain system

- Prepare the Bain system in accordance with the separate Instructions for Use.

For the specified monitoring of O₂, CO₂ and anaesthetic agents:

- 1 Screw the sample line to the Luer lock connection of the mask manifold pipe and to the water trap on the back of the workstation.

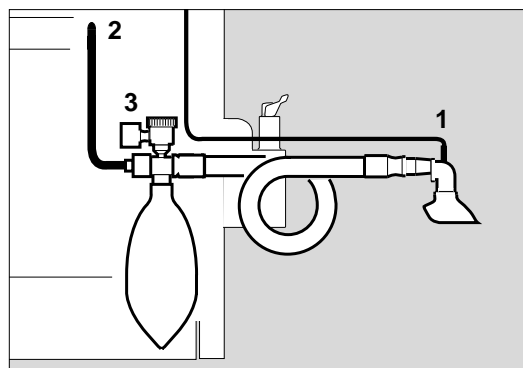

For mask pipes without sample line connector:

- Place a T-piece with filter between the mask pipe and fresh gas connection port.

or:

- where applicable, use the Luer lock connection of a filter.

- 2 Connect the fresh gas hose of the Bain system to the fresh gas outlet.

- 3 Connect the anaesthetic gas scavenging system AGS to the Bain system.

- Note the Instructions for Use of the Bain system.

Display (example):

In **MAN/ SPONT** ventilation mode:

- Press the softkey »**Fresh gas internal/ external**«, select »**Fresh gas external**« and confirm by pressing the rotary knob.

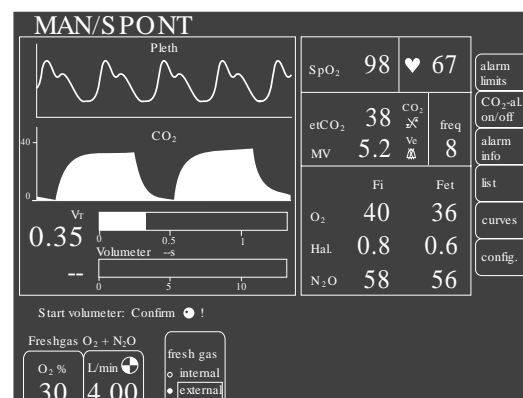

Care

Contents

Dismantling components	96
Dismantling sample line.....	96
Removing water trap container.....	96
Removing breathing hoses.....	96
Removing microbial filters.....	97
Dismantling the suction system.....	98
Dismantling the breathing system.....	99
Removing the flow sensor.....	99
Removing the absorber and bellows.....	99
Opening the breathing system.....	100
Dismantle the anaesthetic gas scavenging system AGS.....	100
Removing waste gas connector.....	101
Dismantling emergency ventilation bag.....	101

Disinfecting / cleaning / sterilizing	102
Breathing system.....	102
Surfaces.....	102
Flow-Sensor.....	102
Microbial filter 654 St.....	103

Care list for Julian anaesthetic workstation	104
---	-----

Assembling	106
Installing the breathing system.....	106
Inserting the flow sensor.....	106
Installing the bellows.....	107
Filling and installing the absorber.....	107
Installing the breathing hoses.....	108
Preparing the suction system.....	108
Connecting the measured gas recirculation system.....	109
Fitting waste gas connector.....	110
Sample gas scavenging.....	110
Fitting emergency ventilation bag.....	111
Connecting the anaesthetic gas scavenging system AGS.....	111

Display (example):

The airway pressure (PAW), minute volume (MV) and frequency are not measured.

- Set the fresh gas flow. The fresh gas supply must be at least twice the minute volume in order to prevent rebreathing.

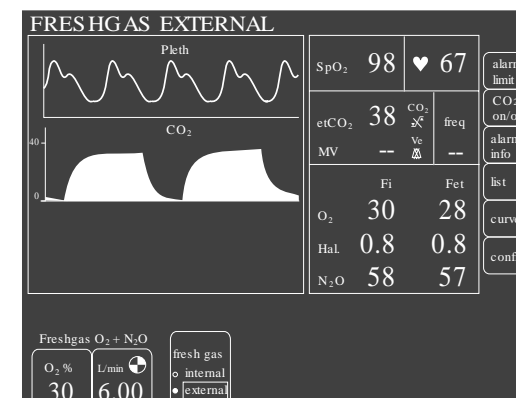

Certain alarms are automatically switched off in order to avoid artefacts.

The inactive alarm limits are highlighted by the grey background in the following table.

Alarm limits	In external fresh gas mode	Default setting on delivery
SpO2 <input checked="" type="checkbox"/>	ON ON	-- 92
Pulse <input checked="" type="checkbox"/>	ON ON	120 50
etCO2 <input checked="" type="checkbox"/>	ON ON	50 (mmHg) --
FiCO2 <input checked="" type="checkbox"/>	ON	Fixed upper alarm limit 5 mmHg
MV <input checked="" type="checkbox"/>	OFF OFF	-- --
FiO2 <input checked="" type="checkbox"/>	OFF ON	-- 20
Fi Hal. <input checked="" type="checkbox"/>	ON OFF	1.5 --
Fi Iso. <input checked="" type="checkbox"/>	ON OFF	2.3 --
Fi Enf. <input checked="" type="checkbox"/>	ON OFF	3.4 --
Fi Des. <input checked="" type="checkbox"/>	ON OFF	12.0 --
Fi Sev. <input checked="" type="checkbox"/>	ON	3.4
PAW <input checked="" type="checkbox"/>	ON OFF	40 --
Apnoea pressure	OFF	
Apnoea flow	OFF	
Apnoea CO2	ON	

Operation
Using non-rebreathing systems
In the event of a power failure

Switch off the external fresh gas output:

- Press the softkey »Fresh gas internal/ external« and confirm by pressing the rotary knob.
Julian switches over to **MAN/ SPONT** ventilation mode or
- Press the »IPPV« or »PCV« key and confirm with the rotary knob.
Julian then switches over directly to controlled ventilation via the original rebreathing system.

When changing from the external non-rebreathing system to the rebreathing system of the Julian:

- Reconnect the sample line to the Y-piece.

In the event of a power failure

Julian automatically switches over to the integrated uninterruptible power supply (UPS).
If the battery is charged, operation will be maintained for an average of 30 minutes.

The message

POWER FAIL!

appears on the screen

together with the remaining available battery capacity in percent.
Example:

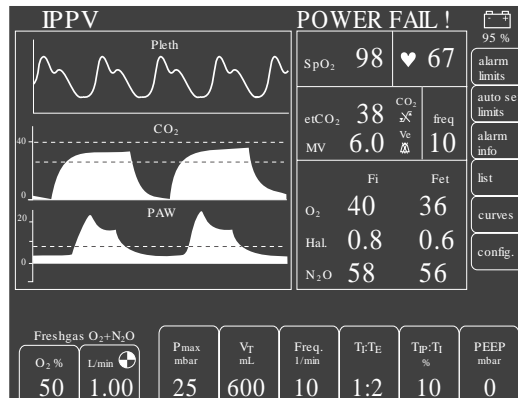

If the battery is almost completely discharged, the message **BATTERY LOW !!!** appears on the screen.

In the event of a power failure if the battery is discharged, Julian switches over automatically to **MAN/ SPONT** ventilation mode. The fresh gas mixer is deactivated.

Version without rotary knob for O₂ emergency metering:

Julian automatically delivers an O₂ flow of 4 L/min. This O₂ flow bypasses the Vapor unit, and so the patient no longer receives any anaesthetic agent.

Version with rotary knob for O₂ emergency metering:

- Set rotary knob »Safety-O₂« for O₂ emergency metering to the desired O₂ flow.
Range 0 to 12 L/min.
This O₂ flow flows through the Vapor unit.

- Check Vapor unit setting.

- **Ventilate patient manually!**

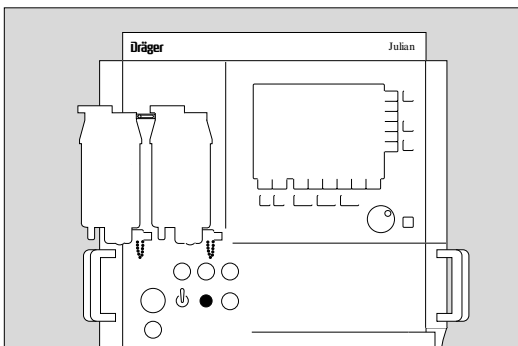

O₂ linearity test

- First perform the "100 vol.% O₂ calibration".
Then:
- Turn the rotary knob to select the line »linearity test O₂« and press to confirm.

After approx. 20 seconds:

- Display (example):
O₂ 21 vol.%
A display in the range between 18 and 24 vol.% is correct.
If the display is outside this range, the O₂ sensor is defective or spent (replace O₂ sensor, see page 117).

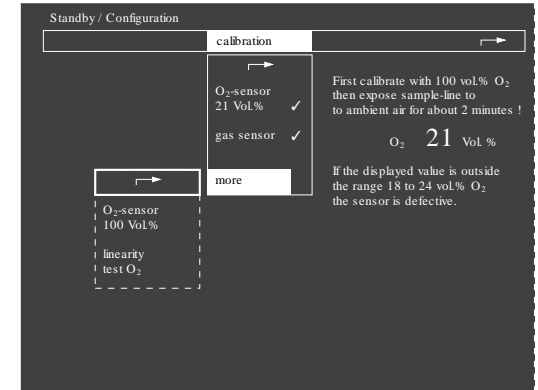

Selecting anaesthetic agent

Julian automatically recognizes the anaesthetic agent used and switches measurement and monitoring of the anaesthetic agent concentration to the identified gas.

If »auto« is selected in the menu »anesth. agent«, the anaesthetic agent is selected automatically.

The anaesthetic agent can also be selected manually:

- Turn the rotary knob to select the column »anaesth. agent« and press to confirm.

Under the »selection« line:

- Turn the rotary knob to select »man« and press to confirm.
- Turn the rotary knob to select the line »gas« and press to confirm.
- Turn the rotary knob until the required gas appears in the display window.
Press the rotary knob to confirm the selection.
- Check that the manually selected anaesthetic agent is compatible with the Vapor unit.

The user is responsible for manual selection of the anaesthetic agent and for correctly filling the anaesthetic vaporizer!

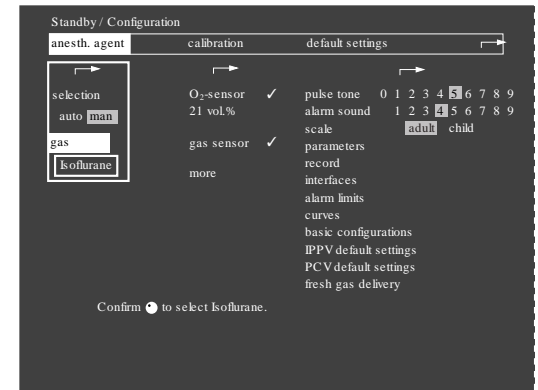

Manual calibration

Julian calibrates its sensors automatically during operation. The message **CAL** appears instead of the current measured value during a calibration process. Calibration of the O₂ sensor and zero calibration of the other gas sensors can be repeated manually, for instance if automatic calibration was unsuccessful.

In standby / configuration mode:

- Turn the rotary knob to select the »**calibration**« column and press to confirm.
- Select and confirm the appropriate line with the rotary knob, for example:
»**O₂-sensor**
21 vol.% «

The calibration process is started when the selection is confirmed. The clock symbol ⌚ appears after the relevant line, i.e. calibration is in progress.

When calibration is complete, a tick (✓) appears instead of the clock symbol. A question mark (?) indicates that calibration must be repeated because the previous calibration was defective.

To improve the measuring accuracy of high O₂ concentrations, an additional 100 vol% O₂ calibration and a linearity test of the O₂ sensor can be performed under the menu option »**more**«.

Other settings can already be made during the calibration process.

100 Vol.% O₂ calibration

- Use a separate O₂ source, e.g. O₂ flowmeter. O₂ from the Julian breathing system is not suitable, as it still contains traces of anaesthetic gas.
- Unscrew the sample line from the Y-piece and place it in the continuous flow of the O₂ source.
- Turn the rotary knob to select the line »**O₂-sensor**
100 vol.% « and press to confirm.
- Allow the O₂ flow to continue flowing into the sample line.

A tick (✓) appears after the field when calibration is complete.

- Screw the sample line back on to the Y-piece.

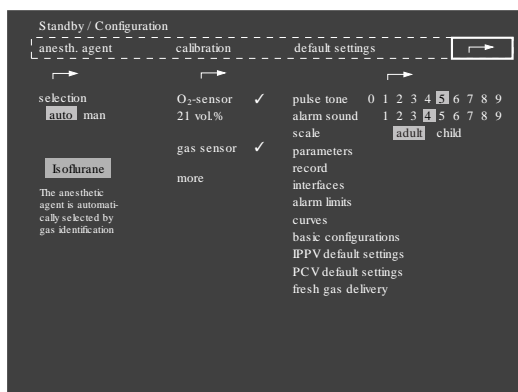

In the event of a gas failure

Julian activates an alarm if the O₂ or AIR or N₂O supply fails.

- Open the valve on the corresponding backup gas cylinder on the rear of the workstation.
- Reconnect the central gas supply.

If there is no backup supply of gas available, Julian replaces the set gas mixture with AIR or O₂:

Julian delivers 100 % AIR if the O₂ supply fails.
Julian delivers 100 % O₂ if the N₂O supply fails.
Julian delivers 100 % O₂ if the AIR supply fails.

The amount of fresh gas flow (L/min) remains constant.

Fresh gas metering is still possible even in the event of failure of one of the gases. For example, if the N₂O supply fails, AIR can be selected as the carrier gas.

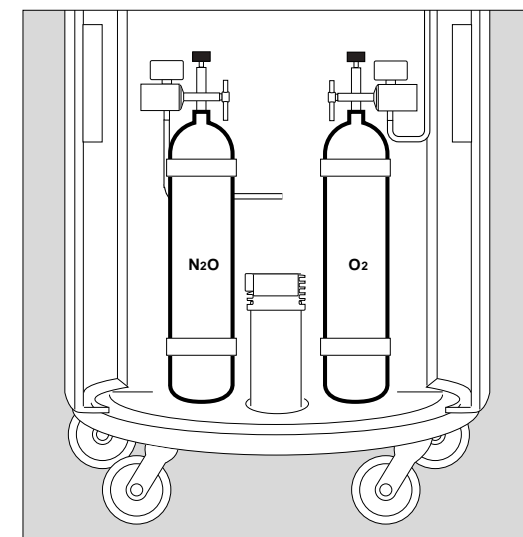

In the event of a Major Hardware Fault

such as the failure of the fresh gas mixer, the message: **SYSTEM FAULT!!!** will be displayed.

In the event of total system failure including the screen, an alarm will sound for about 30 seconds. In such cases Julian switches to **MAN/ SPONT** ventilation mode.

Version without rotary knob for O₂ emergency metering:

Julian automatically delivers an O₂ flow of 4 L/min*. This O₂ flow bypasses the Vapor unit, and so the patient no longer receives any anaesthetic agent.

Version with rotary knob for O₂ emergency metering:

- Set rotary knob for O₂ emergency metering to the desired O₂ flow.
Range 0 to 12 L/min.
This O₂ flow flows through the Vapor unit.
- Check the Vapor unit setting.

- **Ventilate the patient manually!**

*C can be adjusted to up to 8 L/min O₂ by DrägerService.

End of Operation

To switch Julian to Standby:

- Press the standby key  and confirm by pressing the rotary knob.
The workstation is now on standby.
The fresh gas flow is switched off.
Manual ventilation is not possible!

The following default values are activated in standby mode:

- Fresh gas default values
- Ventilation parameters
- Alarm limits

To switch Julian off:

- Press the power switch  « down completely.
The apparatus is switched off after 10 seconds.
- Remove the gas supply probes from the wall sockets.
- Leave Julian plugged into the power supply in order to charge the uninterruptible power supply (UPS).

To switch off the anaesthetic gas scavenging system AGS:

- Pull back the black sleeve on the connector of the suction hose to release the connector.

Julian is equipped with a switch-off time-lag. The message "System will be closed down and switched off" appears for 10 seconds after pressing the main power switch. Julian can immediately be restarted by pressing the main power switch again during this time. The switch-off time-lag is not active during the self-test.

Setting the fresh gas default settings

- Select and confirm the line »**fresh gas default settings**« with the rotary knob.
The softkeys for the fresh gas settings are displayed:

Display (example):

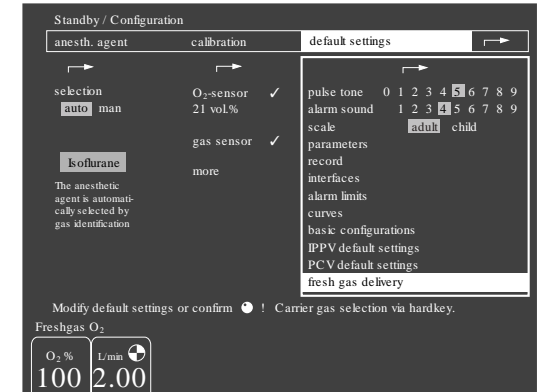

To modify the settings:

- 1 Press the keys »**N2O**« or »**Air**« to select the default carrier gas and press the rotary knob to confirm.
- 2 Press the softkey »**O2 %**«.
Set the default O₂ concentration with the rotary knob and press to confirm.
- 3 Press the softkey »**L/min**«.
Set and confirm the default fresh gas flow with the rotary knob.

To return to the »**fresh gas default settings**« menu:

- Press the rotary knob.

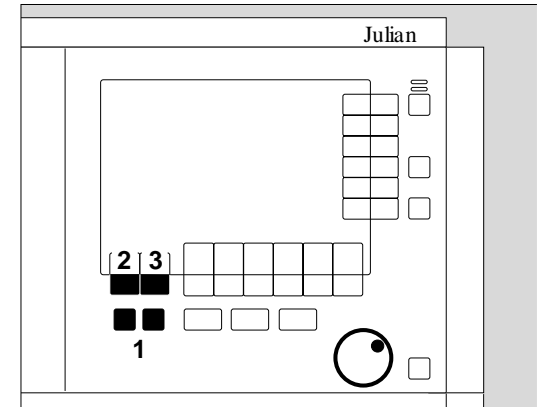

IPPV default settings

- Select and confirm the line »IPPV default settings« with the rotary knob.
The softkeys for IPPV are displayed:

Display (example):

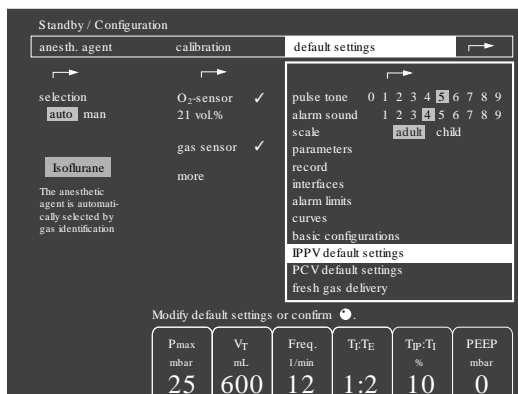

To modify the settings:

- Press the relevant softkey.
- Set and confirm with the rotary knob.

To return to the »default settings«:

- Press the rotary knob.

PCV default settings

- Select and confirm the line »PCV default settings« with the rotary knob.
The softkeys for PCV are displayed:

Display (example):

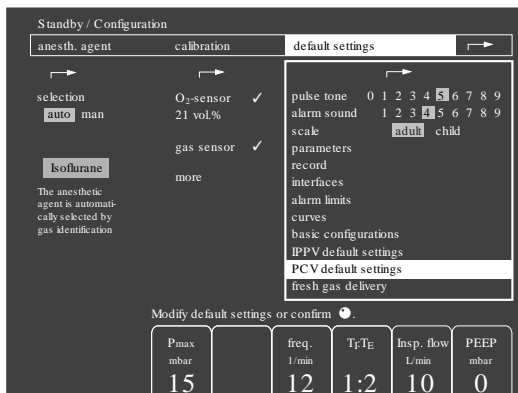

To modify the settings*:

- Press the relevant softkey.
- Set and confirm with the rotary knob.

To return to the »default settings« menu:

- Press the rotary knob.

* Maximum setting for Pmax: 30 mbar.

Monitoring

Contents

Selecting the standard screen..... 56

Selecting the data screen..... 57

Selecting the trend screen..... 58

Zoom function..... 59

To delete the trend memory..... 59

Alarms..... 60

Displaying and setting alarm limits..... 60

Adapting limits – AutoSet..... 62

If an alarm occurs..... 63

Alarm info..... 64

CO2 alarms on / off..... 64

List display..... 65

Delete list..... 65

Selecting curves..... 66

Using the volumeter function..... 67

Starting the volumeter..... 67

Configuring in operation..... 68

Setting the monitoring functions..... 69

Setting the pulse tone..... 69

Setting the alarm sound..... 69

Selecting the scale..... 69

Setting the measuring parameters..... 70

Record..... 71

Time..... 71

Activating monitor defaults..... 71

Selecting alarms..... 72

Default..... 72

Alarm mode for the heart-lung machine HLM..... 73

Selecting the anaesthetic agent..... 74

Manual calibration..... 75

SpO2 Measurement (optional)..... 76

Sensor selection..... 76

C-lock-ECG synchronization (optional)..... 77

Tips to prevent artefacts..... 78



Applying the Durasensor DS-100 A..... 79

Airway temperature measurement (optional)..... 80

Monitoring

Selecting the standard screen

The standard screen is automatically displayed on the screen whenever a ventilation mode is selected (MAN/SPONT or IPPV or PCV). This page can always be selected during operation:

- 1 Press the  key
or
- 2 Press the  key several times.

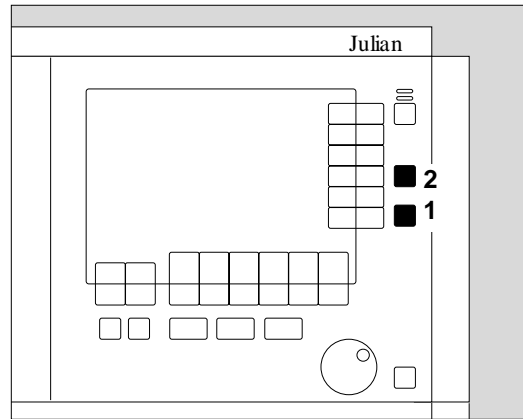

Display (example):

The most important parameters are grouped together on the right-hand side of the screen.

Three curves are displayed on the left-hand side (to select other curves, see page 66).

Measured values shown in grey

Calibration is performed automatically by Julian. The measured values are shown in grey until sufficient data are available and until the sensors have reached their operating temperature.

In this way, Julian indicates that the accuracy of these data is still reduced in comparison with the "Technical data".

For maximum accuracy the sensors can be calibrated manually – see page 75.

When measuring CO₂, anaesthetic agent and N₂O, their numerical values are shown in grey during the warm-up phase whenever the workstation is switched on.

The display **CAL** appears instead of the numerical value during automatic calibration of the O₂ sensor (every 24 hours).

The flow sensor is automatically calibrated as soon as a CO₂ signal is detected by the gas measuring system. Julian takes account of the relevant gas mixture when calculating the volumetric concentrations.

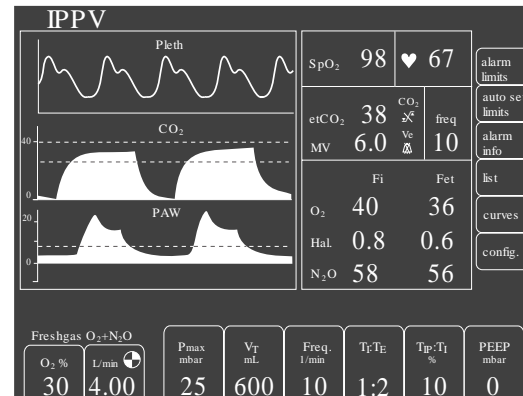

Setting the date/time:

- Select and confirm the »**time**« line with the rotary knob.
The cursor bar marks the hours.
- Press the rotary knob to confirm and the value is highlighted against a white background. It can now be adjusted and confirmed with the rotary knob.
The minutes are adjusted and confirmed in the same way.
- Set and confirm the date as described above.

Setting the language of the display texts:

The last language selected is highlighted by a grey background.

The following alternatives can be selected:

English (GB)	Swedish (SW)
French (F)	Norwegian (N)
German (D)	Portuguese (P)
Dutch (NL)	Polish (PL)
Italian (I)	English (USA)
Spanish (E)	Japanese (Kanji) (JP)
Danish (DK)	

To change the language setting:

- Turn the rotary knob to select the line »**language**« and press to confirm.
- Select and confirm the relevant country code with the rotary knob. The texts in the menu now appear in the language selected.

Setting the tone sequence:

- Turn the rotary knob to select the line »**tone sequence**« and press to confirm.
- Select and confirm either the Dräger alarm tone sequence or the standard European alarm tone sequence.

Configuring in Standby Mode
Setting default values

Configuring curves

Three standard curves can be configured for each of the ventilation modes: MAN/SPONT, IPPV, PCV and Fresh gas external.

- Turn the rotary knob to select the line »curves« and press to confirm. The selection menu appears in the left-hand field.

Display (example):

- Select the required ventilation mode with the rotary knob:

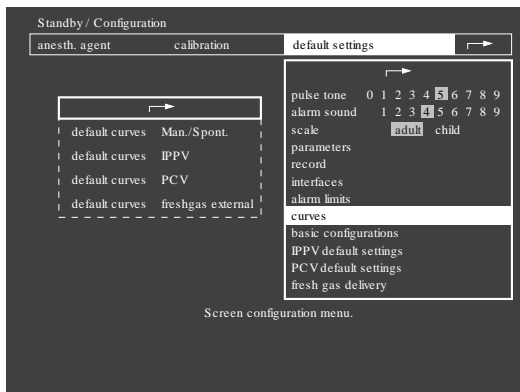

The »Standard IPPV screen« has been selected in the example:

The currently selected parameters appear in the left-hand field, followed by the selection menu with the curves which can be selected.

- Select the required parameter in the selection menu with the aid of the rotary knob and press to confirm. The parameter appears against a white background.
- Select and confirm the position of the new parameter with the rotary knob. The corresponding position remains unused if »blank« is selected.

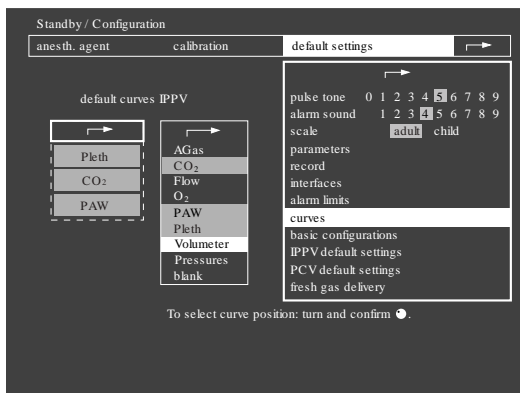

Setting basic configurations

for time, date, language and tone sequence.

- Turn the rotary knob to select the line »basic configurations« and press to confirm. The selection menu appears in the left-hand field.

Display (example):

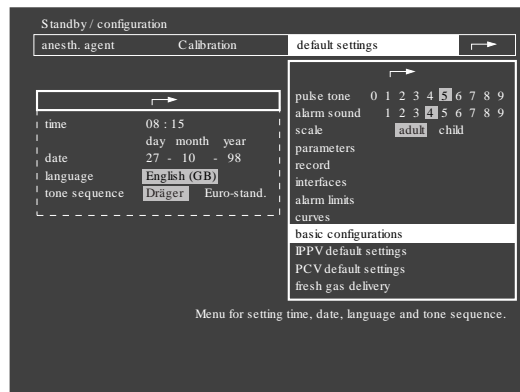

Selecting the data screen

- Press the [F5] key several times until the data page appears.

Display (example):

All numerical values are displayed on the data screen with their units of measure. The bar display on the left of the screen shows the change in airway pressure PAW over time. The lines cutting across the bar graph mark the upper and lower alarm limits. To set the alarm limits for PAW, see page 60.

The system compliance (Sys.-Compl.) and leakage are displayed in the right-hand field, together with the time of the last test.

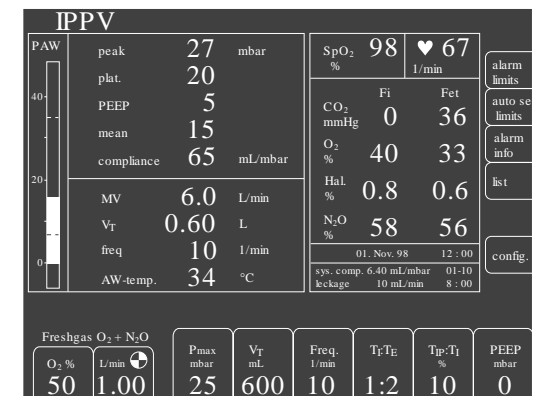

Selecting the trend screen

Displays the measured values over time since the start of measurement.

Maximum storable time: 8 hours.

The following display combinations can be selected:

- CO₂/MV
- AGas/N₂O
- O₂/compliance*
- SpO₂/pulse rate

- Press the  key several times until the trend screen appears.

AMV and compliance trends are scaled in accordance with the setting in the configuration menu for adults or children.

AMV trend scale:

- 0 to 3 L/min for children
- 0 to 15 L/min for adults

Compliance trend scale:

- 0 to 20 mL/mbar for children
- 0 to 100 mL/mbar for adults

Display (example):

Trend CO₂ and MV

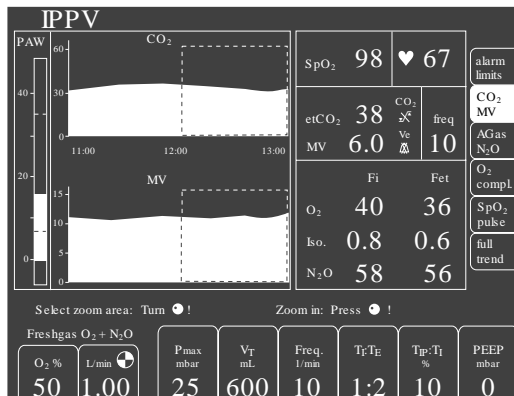

Selecting other display combinations

- Press the appropriate softkey:

- »AGas N₂O«
- or
- »O₂ compl.«
- or
- »SpO₂ pulse«

The softkey disappears if a measuring function is not available.

* Lung properties can be monitored continuously with the compliance trend display so that ventilation can be adjusted accordingly. Patient compliance is not measured in MAN/SPONT ventilation mode.

Adjustment range for default alarm limits

Alarm limit	Adjustment range	Default value set on delivery
SpO ₂ [%]	51 to 100 50 to 99	-- 92
Pulse [1/min]	31 to 300 30 to 299	120 50
etCO ₂ [mmHg]	1 to 75 0 to 74	50 (mmHg) --
MV [L/min]	0.1 to 39 0 to 38.9	12 3.0
FiO ₂ [Vol.%]	19 to 100 18 to 99	-- 20
Fi Hal. [Vol.%]	0.1 to 7 0 to 6.9	1.5 --
Fi Iso. [Vol.%]	0.1 to 7 0 to 6.9	2.3 --
Fi Enf. [Vol.%]	0.1 to 7 0 to 6.9	3.4 --
Fi Des. [Vol.%]	0.1 to 21.9 0 to 21.8	12.0 --
Fi Sev. [Vol.%]	0.1 to 9.9 0 to 9.8	3.4 --
PAW [mbar]	5 to 98 0 to 35	40 8

Fixed alarm limits / times:

- FiCO₂ Fixed upper alarm limit 5 mmHg (deactivated in MAN/SPONT).
- Apnoea pressure after 15 seconds
- Apnoea flow after 15 seconds
- Apnoea CO₂ after 15 seconds (after 60 seconds in MAN/SPONT)

-- : The default value set on delivery is outside the monitoring range and the corresponding alarm limit is therefore switched off.

The newly set default alarm limits are valid whenever the apparatus is switched on or started up from standby mode.

Certain alarm limits are switched off automatically in MAN/SPONT ventilation mode and when using the external fresh gas outlet: see tables, alarm limits for MAN/SPONT, page 39 and alarm limits for non-rebreathing systems, page 51.

Interface

Choice between configuration of COM2 or COM3.

Baud rate

Transmission speed (variable, see Instructions for Use of the equipment to be connected).

Parity

This display is invariable for MEDIBUS and is shown only for information.

Data bits

This display is invariable for MEDIBUS and is shown only for information.

Stop bits

This display is invariable for MEDIBUS and is shown only for information.

Setting default alarm limits

- Turn the rotary knob to select the line »alarm limits« and press to confirm. The »alarm limits« menu appears in the left-hand field.

Display (example):

- Select and confirm the required alarm limit with the rotary knob. The default alarm limit is highlighted against a white background.
- Set and confirm the value with the rotary knob. The value is then displayed in normal mode. The cursor bar jumps to the next default alarm limit.
- Set the next default alarm limit as described above.

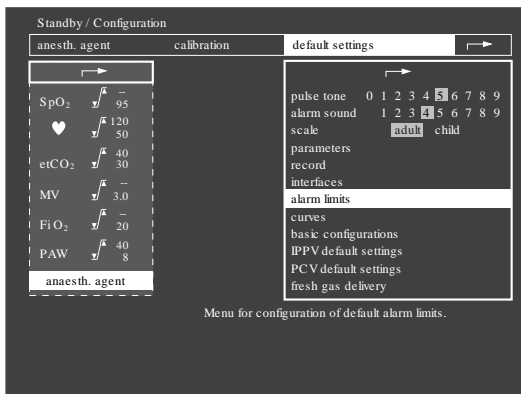

Setting default alarm limits for anaesthetic agents

- Turn the rotary knob to select the line »anaesth. agent« and press to confirm. The corresponding menu is displayed.

Zoom function

The trend display can be magnified with the zoom function after half-an-hour of operation.

To select the range:

- Turn the rotary knob = the dashed frames move.

To enlarge the selected area to the full width of the display:

- Press the rotary knob. A new dashed frame appears after a corresponding period of operation and can also be enlarged.

To return to the overall trend:

- Press the softkey »full trend« and the complete trend is displayed again.

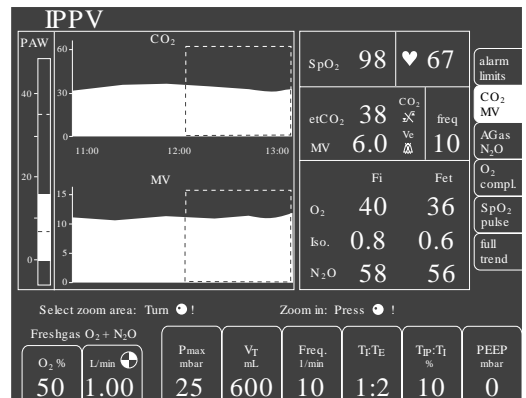

To delete the trend memory

Only possible in standby mode. The trend memory and list are deleted together!

In standby mode:

- Press the softkey »delete trend«.

The system asks you to confirm that the trend is really to be deleted.

To delete:

- Press the softkey »delete«.

The stored trend for the anaesthetic gas concentration is deleted automatically when a new anaesthetic gas is selected.

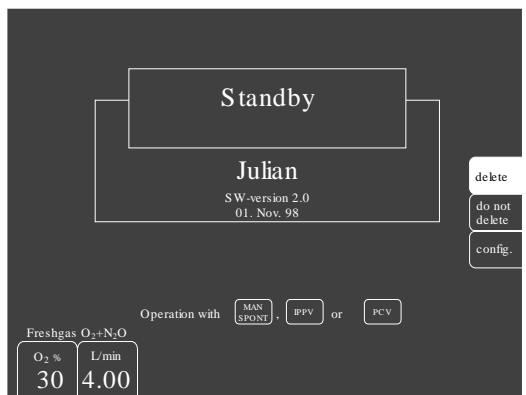
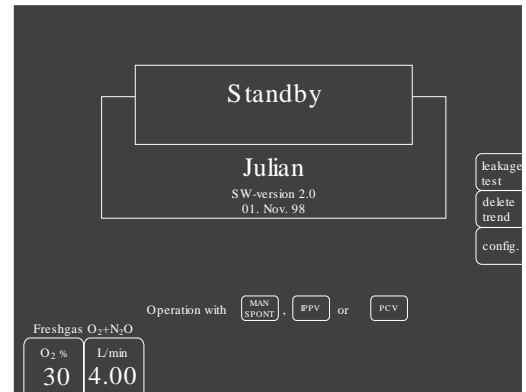

Alarms

Displaying and setting alarm limits

Alarms can be displayed and set from all three basic screens (standard, data and trend screen) during operation.

The default alarm limits for the ventilation mode are activated automatically when changing from standby to a ventilation mode.

These default alarm limits can be used unchanged or they can be set individually for the patient.

The individual settings are deleted on changing from ventilation mode to standby and the default alarm limits are reactivated.

To call up alarm limits:

- Press the softkey »alarm limits«.

Display (example):

The measured values and their alarm limits are shown on the right-hand side.

The curves with the alarm limits represented by dashed lines are shown on the left.

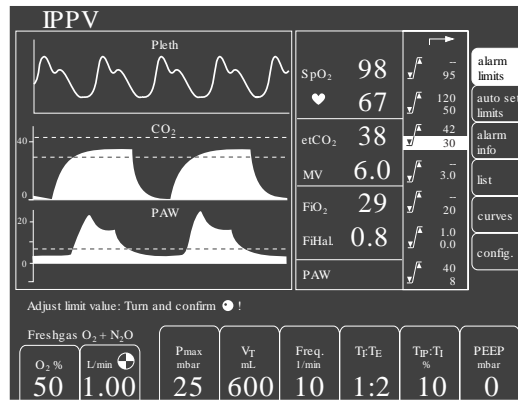

Example etCO2:

The upper alarm limit (42 mmHg) and the lower alarm limit (30 mmHg) are shown alongside the measured value (38 mmHg).



A deactivated alarm limit is indicated by two dashes (--).

To set an alarm limit:

- Place the cursor bar on the alarm limit by turning the rotary knob and press to confirm. The alarm limit is highlighted.
- Set the new value by turning the rotary knob and press to confirm. The new alarm limit is now effective. The cursor bar returns to the → symbol.

Record

This function is used to determine the type of event that triggers an entry in the record list or a printout on the connected record printer.

- Select the line »record« with the rotary knob and press to confirm. The »record« menu appears on the left-hand side.

Display (example):

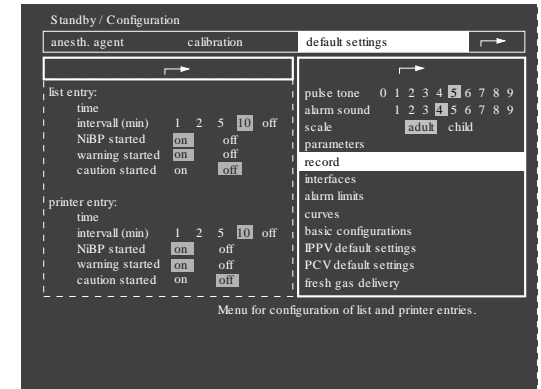

Time

interval-started (min)

A list entry is activated after a fixed time interval in minutes.

NiBP-started

An entry is made after every NiBP measurement with new measured values. This entry can be read by an external Dräger monitor via the MEDIBUS interface.

Warning-started

An entry is made whenever an alarm is triggered.

Caution-started

An entry is made whenever a caution message is triggered.

- Turn the rotary knob to select the event triggering the entry and press to confirm.

Configuring the interfaces

Julian has three serial interfaces:

COM1, COM2, COM3.

COM2 and COM3 are configured as MEDIBUS* interfaces and COM1 as printer interface. The interfaces can be adapted to the connected equipment.

- Turn the rotary knob to select the line »interfaces« and press to confirm. The »interfaces« menu appears in the left-hand field.

Display (example):

COM2 is configured in the upper half of the menu and COM1 and COM3 in the bottom half.

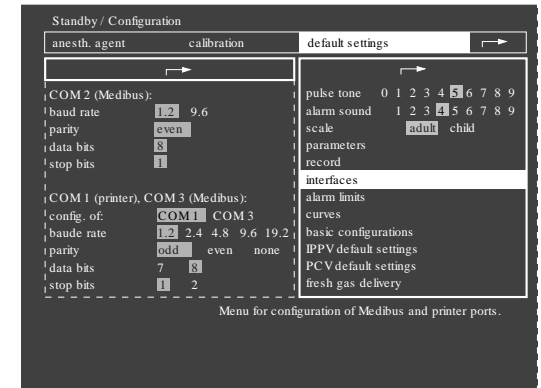

* MEDIBUS: Dräger communications protocol for medical equipment.

Setting the measuring parameters

- Select the line »**parameters**« with the rotary knob and press to confirm.

The »**parameters**« menu appears in the left-hand field.

Display (example):

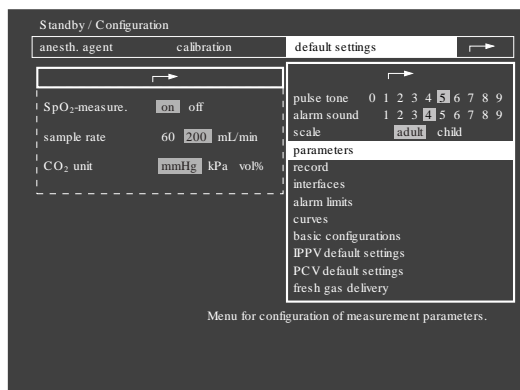

Switch SpO₂ measurement (optional) on/off:

- Select the line »**SpO₂ measurement**« with the rotary knob and press to confirm.
- Select »**on**« or »**off**« with the rotary knob and press to confirm.

Select the sample rate for gas measurement:

- Select the line »**sample rate**« with the rotary knob and press to confirm.
- Select »**60**« or »**200 mL/min**« with the rotary knob and press to confirm.

For paediatric use:

- Select a sample rate of 200 mL/min in order to obtain more accurate values on account of the high frequencies and time constant of the measuring system.
- Recirculate the measured gas, see page 109.

If the measured gas is not recirculated:

- Increase the minute volume accordingly in order to maintain the volume balance.

For adult use:

- Select a sample rate of 60 or 200 mL/min.
Recommendation: select 200 mL/min and recirculate the measured gas, see page 109.

Set CO₂ unit:

- Select the line »**CO₂ unit**« with the rotary knob and press to confirm. The last value selected is highlighted by a grey background.
- Select the required unit of measure by turning the rotary knob and press to confirm.

Adjustment range of the alarm limits

Alarm limit		Adjustment range
SpO ₂ [%]	✓/✗	51 to 100 50 to 99
Pulse [1/min]	✓/✗	21 to 250 20 to 249
etCO ₂ [mmHg]	✓/✗	1 to 75 0 to 74
MV [L/min]	✓/✗	0.1 to 39 0 to 38.9
FiO ₂ [Vol.%]	✓/✗	19 to 100 18 to 99
Fi Hal. [Vol.%]	✓/✗	0.1 to 7 0 to 6.9
Fi Iso. [Vol.%]	✓/✗	0.1 to 7 0 to 6.9
Fi Enf. [Vol.%]	✓/✗	0.1 to 7 0 to 6.9
Fi Des. [Vol.%]	✓/✗	0.1 to 21.9 0 to 21.8
Fi Sev. [Vol.%]	✓/✗	0.1 to 9.9 0 to 9.8
PAW [mbar]	✓/✗	5 to 98 0 to 35

To quit the **alarm limits** menu:

- Press the rotary knob
or
- Press the  key.

Adapting limits – AutoSet

When the ventilation settings have been made, Julian can automatically adapt the alarm limits for the minute volume (MV) and airway pressure (PAW) to the current ventilation settings in IPPV mode.

- Press the softkey »**auto set limits**«.

The new alarm limits for the set MV and PAW are calculated by Julian as follows:

	Upper alarm limit	Lower alarm limit
MV [L/min]	VT x f x 1.4 At least 2.0	VT x f x 0.6 At least 0.5
PAW [mbar]	(Pmax + 10)	$PEEP + \frac{P_{max} - PEEP}{4}$

To reset individual alarm limits for MV and PAW:

- See "Displaying and setting alarm limits" on page 60.

To reuse all default alarm limits:

- See "Configuring in standby mode, setting default alarm limits" on page 72.

The menu requests the user to enter a 4-digit password in order to prevent unauthorized tampering with the basic settings. This password is notified during system training. The function can be disabled by DrägerService if required.

- Turn the rotary knob to select the digits consecutively from the line provided and press to confirm. The password is indicated underneath with asterisks (* * * *). The menu for selecting the default settings appears when the password has been entered correctly.

Display (example):

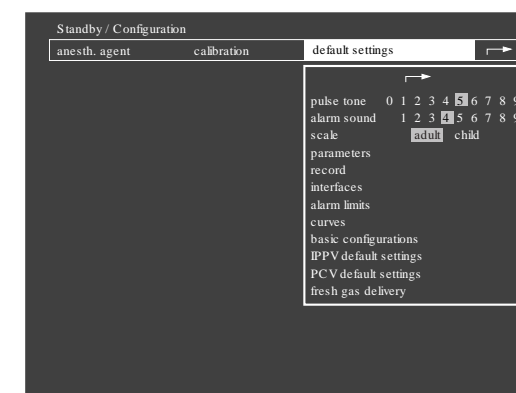

Setting the pulse tone (optional)

0 = OFF

9 = Maximum volume

- Select the line »**pulse tone**« by turning the rotary knob and press to confirm. The cursor automatically jumps to the last value selected (example 5).
- Set the value with the rotary knob and press to confirm.

Setting the alarm sound

1 = Minimum volume

9 = Maximum volume

- Select the line »**alarm sound**« by turning the rotary knob and press to confirm. The cursor automatically jumps to the last value selected (example 4).
- Set the value with the rotary knob and press to confirm.

Set a sufficiently loud alarm sound!

The audible »**NO O₂**« and »**NO FRESH GAS**« alarms are always sounded at maximum volume.

Julian complies with national regulations in certain countries that stipulate a minimum volume of 45 dB (A). Settings 1 to 4 are programmed at 45 dB (A) for these countries.

Selecting the scale

To adapt the scale for the volumeter function and trend curve.

- Select the line »**scale**« with the rotary knob and press to confirm.
- Select »**adult**« or »**child**« with the rotary knob and press to confirm.

Configuring in Standby Mode

The default settings for the monitoring functions and the fresh gas and ventilation parameters can be configured in standby mode. The default settings for the monitoring functions and the choice of anaesthetic gas are valid whenever the apparatus is switched on. The default values for the alarm limits, fresh gas parameters and ventilation parameters are valid after each standby.

- Switch Julian to standby mode.
- Press the softkey »config.«

Display (example):

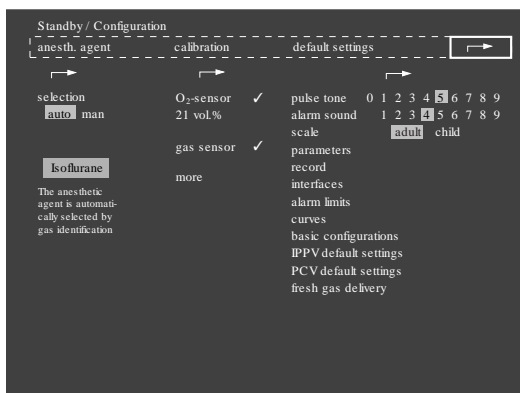

The following settings can be made in the menu:

- Default settings
- Calibration
- Anaesth. agent

Fields highlighted by a grey background contain the currently valid settings.

The symbol ↩ indicates a return to the previous menu level.

- Select, set and confirm the new settings with the rotary knob.

Setting default values

Default values are valid whenever the apparatus is switched on. The default monitoring settings can be activated during operation with **activate monitor defaults**, see "Activating monitor defaults" on page 71.

- Select and confirm the **default settings** with the rotary knob.

Display (example):

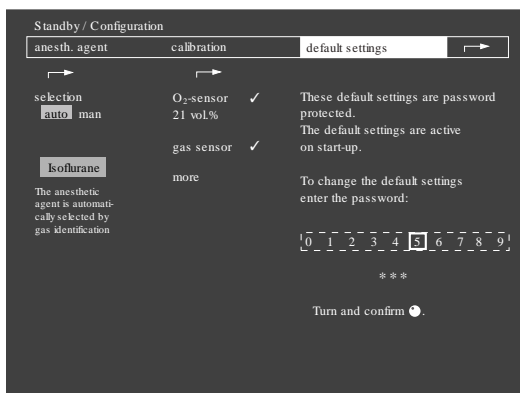

If an alarm occurs

Alarm messages are assigned to three priority classes by Julian, depending on their urgency, and identified by exclamation marks:

Warning !!! = message with top priority
A warning message requires immediate action

Caution !! = message with medium priority
A caution message requires prompt action

Advisory ! = message with lowest priority
An advisory message requires to be noted and action taken if necessary

If several alarms occur simultaneously, Julian displays the alarm with the highest priority. The others are not displayed.

All warning, caution and advisory messages that have been emitted can be displayed by pressing the »alarm Info« softkey.

Each time an alarm message is displayed, the alarm lamp either flashes or lights up continuously and an audible tone sequence is emitted to indicate the alarm priority class:

Warning:

- 1 Red lamp flashes, accompanied by a continuous tone.

Caution:

- 1 Yellow lamp flashes, accompanied by an intermittent tone every 30 seconds.

Advisory:

- 1 Yellow lamp lights up continuously, accompanied by a single tone.

The alarm tone can be suppressed for two minutes:

- 2 Press the key and its yellow LED lights up.

To reactivate the alarm tone:

- 2 Press the key and its yellow LED goes out.

A list of alarm messages can be found on page 120, "Message – Cause – Remedy".

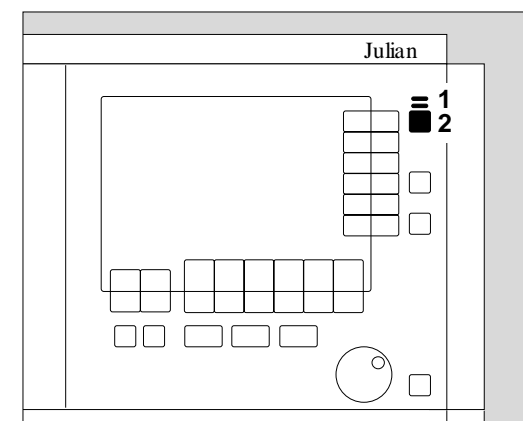

Alarm info

This function is used to list all active alarms / warnings in order of priority.

- Press and hold the softkey »alarm info«.

Display (example):

Active alarms:

FIO₂ ✓ !!!

Active warning:

ETCO₂ ✓ !!

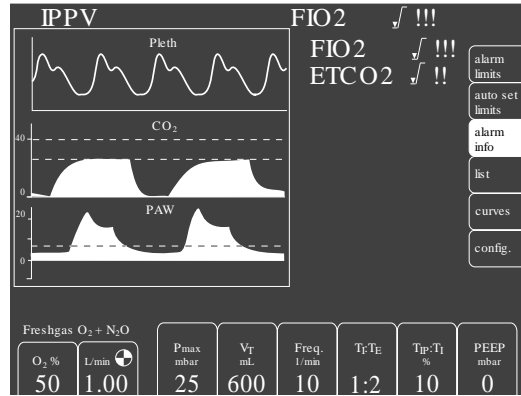

The display only remains visible as long as the softkey is pressed.

CO₂ alarms on / off

The alarm limits for etCO₂, insp. CO₂ and CO₂ apnoea monitoring can be switched off with the softkey »CO₂-al. on/off« in MAN/SPONT mode.

In this case, the symbol **CO₂ ⚡** appears alongside the measured end-expiratory CO₂ concentration.

The CO₂ alarm limits are reactivated by pressing the softkey again. The deactivated CO₂ alarm limits are reactivated automatically when changing to a different ventilation mode.

The CO₂ alarm limits can also be activated and deactivated under "Alarm limits" in the configuration screen in all ventilation modes, see page 72.

National and European standards require a minimum monitoring with alarm function. These standards may not be met if the alarm function of the etCO₂ monitoring parameter is deactivated.

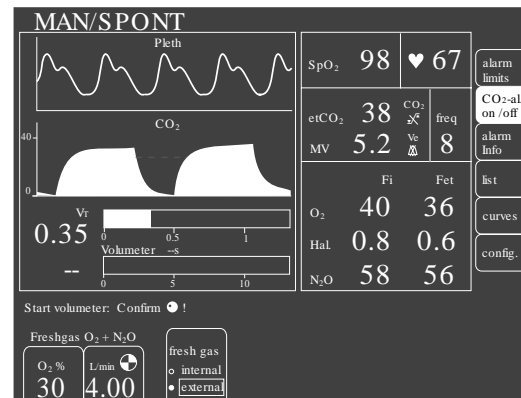

Configuring in Standby Mode

Contents

Setting default values	82
Setting the pulse tone.....	83
Setting the alarm sound.....	83
Selecting the scale.....	83
Setting the measuring parameters.....	84
Record.....	85
Time.....	85
Configuring the interfaces.....	85
Interface.....	86
Setting default alarm limits.....	86
Setting default alarm limits for anaesthetic agents.....	86
Adjustment range for default alarm limits.....	87
Configuring curves.....	88
Setting basic configurations.....	88
IPPV default settings.....	90
PCV default settings.....	90
Setting the fresh gas default settings.....	91
Manual calibration	92
100 Vol.% O ₂ calibration.....	92
O ₂ linearity test.....	93
Selecting anaesthetic agent	93

Airway temperature measurement (optional)

Parts required:

- Temperature sensor 84 05 371
- Y-piece with connection for temperature sensor M 30 543
- T-piece 86 00 224
- Filter 86 00 225

- 1 Connect Y-piece to respiratory hoses.
- 2 Insert T-piece into Y-piece.
- 3 Insert filter into T-piece.
- 4 Insert temperature sensor into Y-piece.

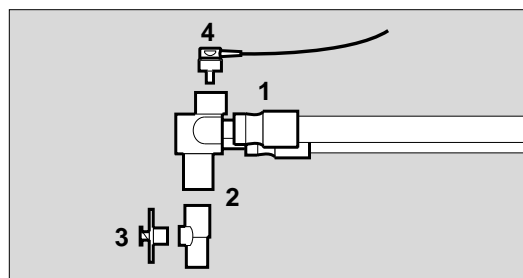

- 5 Connect temperature sensor plug to »Temp.« socket at the back of the workstation.

- The airway temperature is displayed in the data section of the screen:

AW temp. XX °C

The upper alarm limit is fixed. If the airway temperature exceeds 40°C, the »AW Temp / !!!« alarm will be activated.

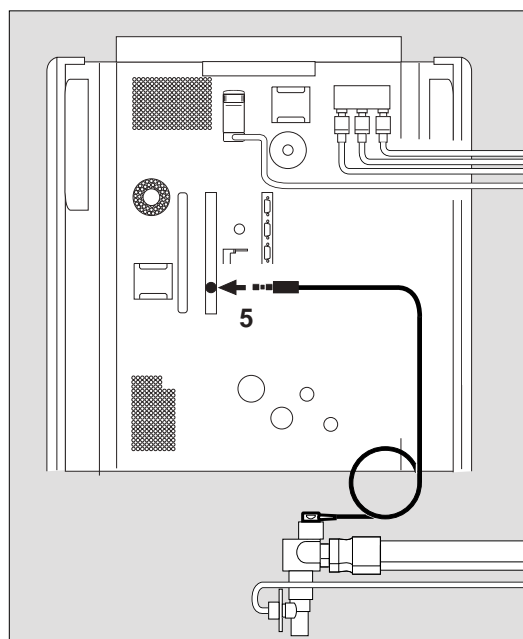

List display

Record of measured values, alarms and ventilation modes to facilitate compilation of the anaesthetic record. The control criteria for entries can be configured, see "Record" on page 71.

- Press the softkey »list«.

Display (example):

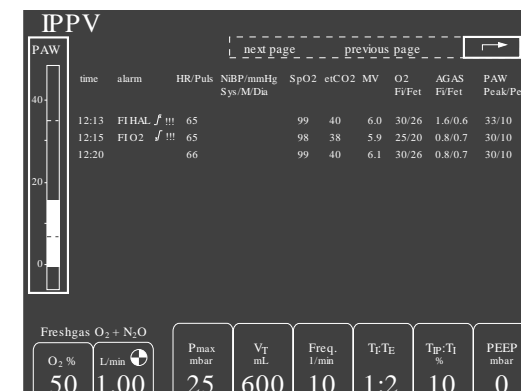

"Open" the previous page:

- Select »previous page« by turning the rotary knob and press to confirm.

"Open" the next page:

- Select »next page« by turning the rotary knob and press to confirm.

Return to the standard page:

- Place cursor on the ↗ symbol by turning the rotary knob and press to confirm.

or

- Press the key.

Delete list

The list and trend memory are deleted together!
Only possible in standby!

In standby:

- Press the softkey »delete trend«.

Delete trends and list:

- Press the softkey »delete«.

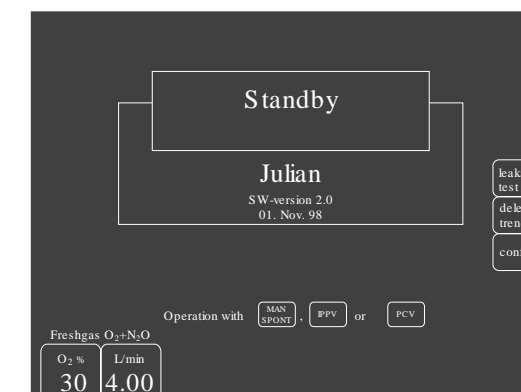

Selecting curves

Only possible from the standard screen!

Three curves can be selected and positioned for the momentary ventilation mode in this menu.

The following curves can be selected:

- AGas** Curve of anaesthetic agent concentration at the Y-piece
- CO₂** Curve of CO₂ concentration at the Y-piece
- Flow** Expiration flow
- O₂** Curve of O₂ concentration at the Y-piece
- PAW** Airway pressure
- Pleth** The plethysmogram derived from SpO₂ measurement (optional)
- Volumeter** A display mode showing the minute volume and tidal volume V_T as bar graphs
- Pressures** Digital indication of the measured value for PPEAK, PPLAT, PMEAN and PEEP
- blank** Blank field

- Press the softkey »curves«.

Display (example):

The names of the curves in each curve field are displayed together with the choice of possible parameters. The current curves are highlighted by a grey background.

In the example, the PAW curve is to be replaced by the volumeter display.

- Turn the rotary knob to select the required parameter (»volumeter«) and press to confirm.

The cursor jumps to the → symbol of the positioning menu.

- Select the desired position with the rotary knob and press to confirm.

Display (example):

The curve is replaced and the cursor returns to the → symbol in the selection menu.

To return to the standard page:

- Press the rotary knob.

If a curve field is to remain blank:

- Select »blank« with the rotary knob and press to confirm.

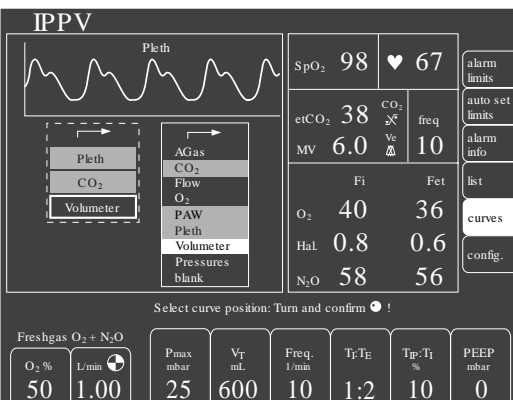
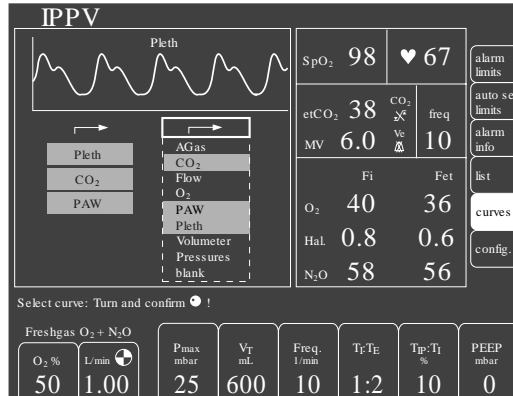

Applying the Durasensor DS-100 A

Reusable sensor for short-term monitoring of relatively quiet patients weighing over 40 kg.

The sensor is preferably positioned on the index finger, although other fingers can also be used. The little finger should be used if the patient is particularly large or obese.

- Open the clip slightly and slide the sensor onto the finger. The tip of the finger must touch the end and the soft padding should rest on the nail and tip of the finger. The lead should be on top of the finger.
- Ensure that the finger is not compressed or hurt by the clip.
- Change the application site after not more than 4 hours in order to avoid a build-up of blood pressure (blocked circulation).

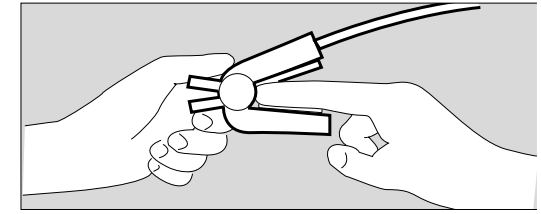

Follow the specific Instructions for Use when using other Nellcor sensors!

Tips to prevent artefacts

Only use Nellcor sensors in the recommended positions, otherwise incorrect measurements and tissue damage may result.

Damaged sensors with exposed electrical contacts must not be used – danger of electric shock.

Used adhesive strips of the Oxiband-OXI-A/N and OXI-P/I sensor must not be reused, as they may not adhere properly.

The strips must not be stretched unduly. Never use two strips together, as this may lead to venous pulsation and failure of the pulse signal.

High intrathoracic pressure, pressure on the thorax and other consecutive impairments of the venous flow can lead to venous pulsation with failure of the pulse signal.

The pulse signal may fail in the presence of shock, low blood pressure, severe vasoconstriction, major anaemia, hypothermia, arterial occlusion proximal to the sensor and asystolia.

The sensor must be protected from exposure to bright light (e.g. surgical lamps and direct sunlight), otherwise the pulse signal may fail or inaccurate results may be obtained.

The sensor should not be positioned on limbs together with an arterial catheter, sphygmomanometer cuff or intravascular venous infusion, otherwise the pulse signal may fail and measurement become inaccurate.

Measurement accuracy may be reduced in the presence of significant concentrations of dyshaemoglobins, such as carboxyhaemoglobin or methaemoglobin.

Intravascular dyes, such as methylene blue, may also impair measurement accuracy.

Electrocautery can impair the measuring accuracy; the leads and sensor should therefore be positioned as far away as possible from the electrocautery and its neutral electrode.

Sensor performance may be impaired and lead to inaccurate results if the patient moves violently. The sensor should be applied to a different site in such cases in order to reduce the risk of artefacts due to movement.

Using the volumeter function

To observe and assess ventilation in manual and pressure controlled ventilation modes and during spontaneous breathing.

- ① Upper bar: Current tidal volume V_T, preceded by the numerical value.
- ② Lower bar: Volumeter (minute volume measurement), preceded by the numerical value.

The scale of the bar display depends on the default setting, see "Configuring in operation, selecting the scale" on page 69 and "Configuring in standby mode, selecting the scale" on page 83.

Setting	Tidal volume V _T in L	Minute volume MV in L/min
Scale for children	0.2	2
Scale for adults	1.0	10

Starting the volumeter

- Press the rotary knob. The values are deleted and volumeter restarted if the rotary knob is pressed again before 60 seconds have elapsed.

The elapsed time in seconds is displayed above the bar with the summed volume on the left. The individual breaths are separated by segments in the bar. The volumeter stops automatically with an acoustic signal after 60 seconds.

The measured values are displayed for 4 minutes and then erased.

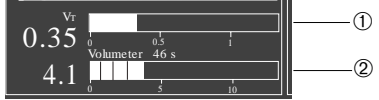
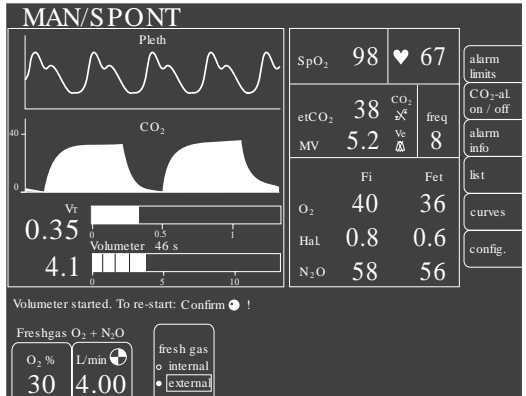

Configuring in operation

The configuration menus are used to select or modify individual monitoring functions for the measurements in progress. The settings entered here are only valid while measurement is in progress and are deleted on switching to standby mode.

In the standard screen (example) or data screen:

- Press the softkey »config.«.

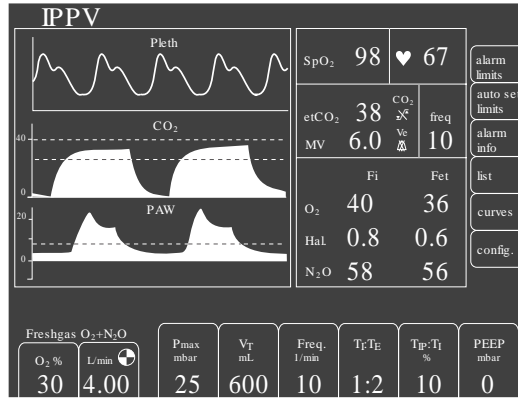

Display (example):

The softkeys for fresh gas and ventilation parameters remain active.

The values highlighted in grey represent the current settings.

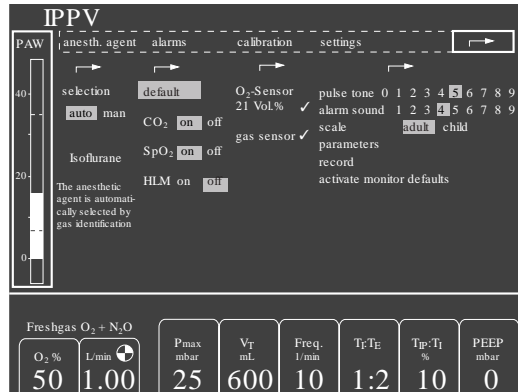

- Select the appropriate sensor.

On the back of the Julian:

- 1 Swing the flap over the socket »SpO₂« to the left and insert the sensor plug.

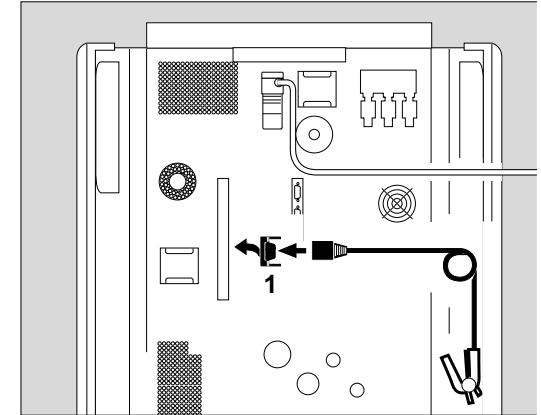

C-lock-ECG synchronization (optional)

If the patient is highly agitated or the arterial flow is very low, the measurement signals of the SpO₂ measurement can be improved with the C-Lock-ECG synchronization. In this case, Julian receives two separate signals that transmit the heart activity:

- An optical signal from the SpO₂ sensor and
- An electrical signal from the separate ECG monitor.

Julian uses the R-wave of the ECG signal to identify the pulse and to synchronize with the SpO₂ measurement.

- 2 Channel the ECG signal of the ECG monitor with the cable and yesck-plug to the back of the Julian (»Sync.« socket). See the "Technical data" on page 131 for the requirements for the electrical signal and plug layout.

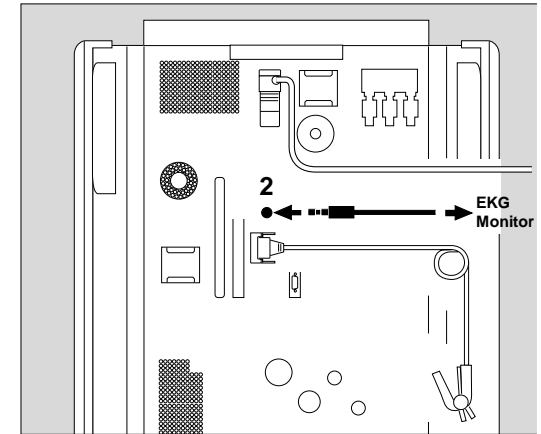

In the event of a delayed ECG signal

Synchronization may be impaired if the ECG signal is delayed by more than 40 milliseconds to the QRS complex.

If you suspect a fault of this kind:

- Use the Julian without C-Lock-ECG synchronization.

SpO₂ Measurement (optional)

Sensor selection

Only use Nellcor sensors.
Note the Instructions for Use of the sensors – incorrect positioning or use can cause tissue damage.

Select the sensor according to the following criteria:

- Patient weight
- Patient mobility
- Possible application site
- Patient perfusion
- Duration of use

The following table listing the specific sensor types available and their characteristics is intended as an aid for selection.

Sensor type	OXISENSOR I-20	OXISENSOR D-20	DURASENSOR DS-100 A	OXISENSOR D-25	OXISENSOR R-15
Age group	Infants	Children	Adults	Adults	Adults
Patient weight	1 to 20 kg	10 to 50 kg	>40 kg	>30 kg	>50 kg
Duration of use	Short and long-term monitoring	Short and long-term monitoring	Short-term monitoring	Short and long-term zeitüberwachung	Short and long-term monitoring
Patient mobility	Limited mobility	Limited mobility	Immobile patients only	Limited mobility	Immobile patients only
Preferred measuring site	Toe	Finger	Finger	Finger	Nose
Sterility ¹⁾	Sterile packaging	Sterile packaging	—	Sterile packaging	Sterile packaging

OXISENSOR™ I-20, OXISENSOR™ D-20, DURASENSOR™ DS-100 A, OXISENSOR™ D-25 and OXISENSOR™ R-15 are registered trademarks.

¹⁾ in unopened, undamaged packaging

Setting the monitoring functions

- Select the »settings« column by turning the rotary knob and press to confirm.

Display (example):

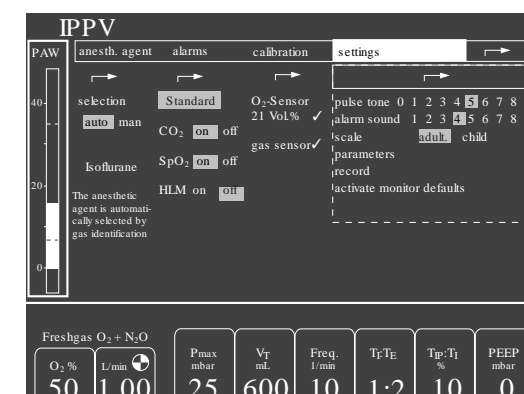

Setting the pulse tone

0 = OFF

9 = Maximum volume

- Select the line »pulse tone« by turning the rotary knob and press to confirm. The cursor automatically jumps to the last value selected (in the example: setting 5).
- Set the value with the rotary knob and press to confirm.

Setting the alarm sound

1 = Minimum volume

9 = Maximum volume

- Select the line »alarm sound« by turning the rotary knob and press to confirm. The cursor automatically jumps to the last value selected (in the example: setting 4).

- Set the value with the rotary knob and press to confirm.

Set a sufficiently loud alarm sound!

The audible »NO O₂« and »NO FRESH GAS« alarms are always sounded at maximum volume.

Julian complies with national regulations in certain countries that stipulate a minimum volume of 45 dB (A). Settings 1 to 4 are programmed at 45 dB (A) for these countries.

Selecting the scale

To adapt the scale for the volumeter function and trend curve.

- Select the line »scale« with the rotary knob and press to confirm.
- Select »adult« or »child« with the rotary knob and press to confirm.

Setting the measuring parameters

- Select the line »**parameters**« with the rotary knob and press to confirm.

The »**parameters**« menu appears in the left-hand field.

Display (example):

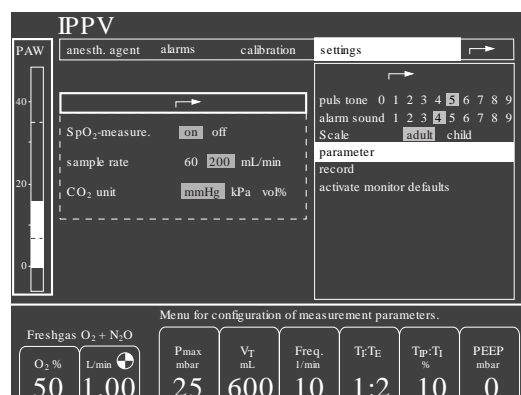

Switch SpO2 measurement (optional) on/off:

- Select the line »**SpO2 measurement**« with the rotary knob and press to confirm.
- Select »**on**« or »**off**« with the rotary knob and press to confirm.

Select the sample rate for gas measurement:

- Select the line »**sample rate**« with the rotary knob and press to confirm.
- Select »**60**« or »**200 mL/min**« with the rotary knob and press to confirm.

For paediatric use:

- Select a sample rate of 200 mL/min in order to obtain more accurate values on account of the high frequencies and time constant of the measuring system.
- Recirculate the measured gas, see page 109.

If the measured gas is not recirculated:

- Increase the minute volume accordingly in order to maintain the volume balance.

For adult use:

- Select a sample rate of 60 or 200 mL/min.
Recommendation: select 200 mL/min and recirculate the measured gas, see page 109.

Set CO2 unit:

- Select the line »**CO2 unit**« with the rotary knob and press to confirm. The last value selected is highlighted by a grey background.
- Select the required unit of measure by turning the rotary knob and press to confirm.

Manual calibration

Julian calibrates its sensors automatically during operation. The message CAL appears instead of the current measured value during a calibration process. Calibration of the O2 sensor and zero calibration of the other gas sensors can be repeated manually, for instance if automatic calibration was unsuccessful.

- Turn the rotary knob to select the »**calibration**« column and press to confirm.
- Select and confirm the appropriate line with the rotary knob, for example:
»**O2-Sensor**
21 vol.% «

The calibration process is started when the selection is confirmed. The clock symbol ⌚ appears after the relevant line, i.e. calibration is in progress.

When calibration is complete, a tick (✓) appears instead of the clock symbol. A question mark (?) indicates that calibration must be repeated because the previous calibration was defective.

Other settings can already be made during the calibration process.

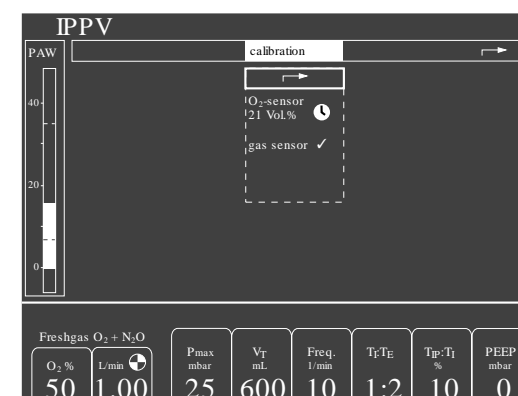
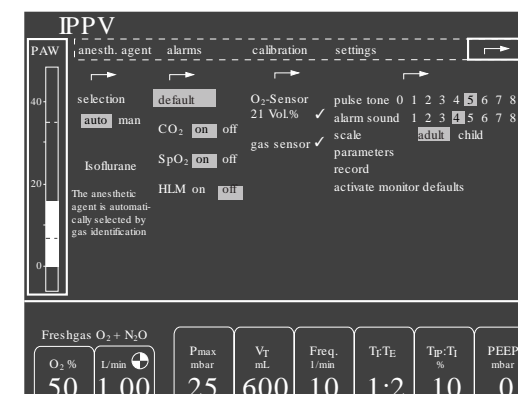

Selecting the anaesthetic agent

Julian automatically recognizes the anaesthetic gas used and switches measurement and monitoring of the anaesthetic gas concentration to the identified gas.

If a mixture of two anaesthetic agents is detected, the system generates a caution message: AGAS MIXTURE !!

The anaesthetic agent with the higher concentration is monitored and displayed. As long as a mixture of two anaesthetic agents is present (e.g. after changing the anaesthetic agent), the values of the anaesthetic agent concentration are displayed in grey = reduced accuracy.

Displays Fi and Fet give information about the anaesthetic agent mixture situation:

Fi display	Fet display	Situation
grey	light	AGAS mixture inspiratory only
grey	grey	AGAS mixture inspiratory and expiratory
light	grey	AGAS mixture expiratory only
light	light	No more AGAS mixture

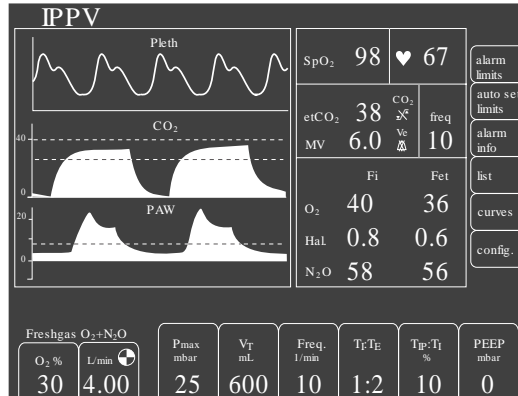

The anaesthetic agent can also be selected manually:

- Turn the rotary knob to select the column »anasth. agent« and press to confirm.
- Turn the rotary knob to select the line »man« and press to confirm.
- Turn the rotary knob to select the column »gas« and press to confirm.
- Turn the rotary knob until the required gas appears in the display window. Press the rotary knob to confirm the selection.

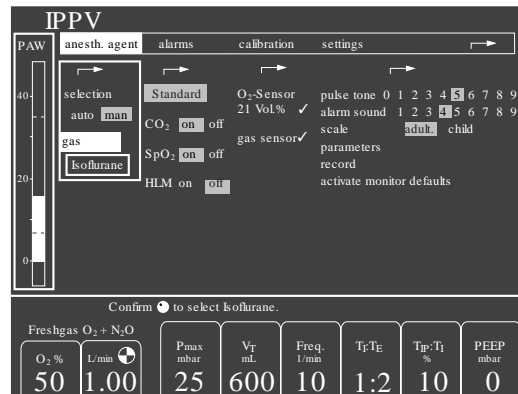

The user is responsible for manual selection of the anaesthetic agent and for correctly filling of the anaesthetic vaporizer!

Record

This function is used to determine the type of event that triggers an entry in the record list or a printout on the connected logging printer.

- Select the line »record« with the rotary knob and press to confirm. The »record« menu appears on the left-hand side.

Display (example):

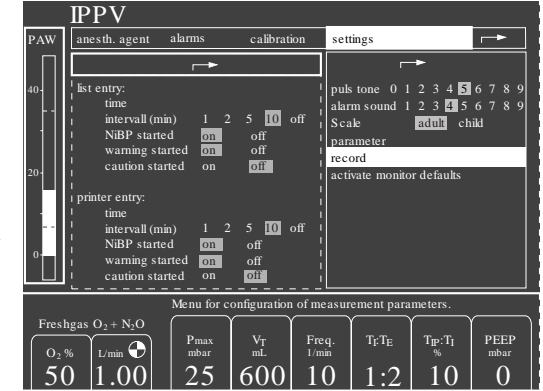

Time interval-started (min)

A list entry is activated after a fixed time interval in minutes.

NiBP-started

An entry is made after every NiBP measurement with new measured values. This entry can be read by an external Dräger monitor via the MEDIBUS interface.

warning-started

An entry is made whenever an alarm is triggered.

caution-started

An entry is made whenever a caution message is triggered.

- Turn the rotary knob to select the event triggering the entry and press to confirm.

Activating monitor defaults

This function is used to activate the default monitoring settings configured in standby mode and active whenever the apparatus is switched on.

- Select the line »activate monitor defaults« with the rotary knob and press to confirm.

Selecting alarms

- Turn the rotary knob to select the column »alarms« and press to confirm.

Default

This function is used to activate the default alarm limits set in the standby configuration which are effective whenever the apparatus is switched to standby.

Setting default alarm limits:

- Select the »default settings« menu by turning the rotary knob and press to confirm. See page 86 for the further procedure.

CO₂ alarms on/off

To activate / deactivate all CO₂ alarms, including the apnoea alarm.

- Turn the rotary knob to select »CO₂ on« or »CO₂ off« and press to confirm.

SpO₂ alarms on/off

To activate/deactivate all SpO₂ alarms.

- Turn the rotary knob to select »SpO₂ on« or »SpO₂ off« and press to confirm.

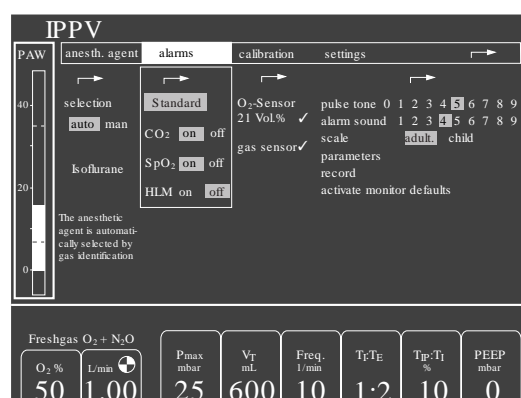

Deactivated alarms are indicated by the symbol \sphericalangle in the measurement field.

National and European standards require minimum monitoring with alarm function. These standards may not be met when the alarm function of the monitoring parameter etCO₂ or SpO₂ is deactivated.

Alarm mode for the heart-lung machine HLM

HLM alarm mode can be used independently of the active ventilation mode for patient monitoring when using the heart-lung machine.

In HLM alarm mode,

- all apnoea alarms are deactivated.
- the gas concentrations are measured continuously regardless of the respiratory phase.
- the SpO₂ alarms are deactivated. They are reactivated automatically when pulsations are detected by the apparatus again after switching off the HLM alarm mode.

Selecting HLM alarm mode

- Press the softkey »config«.
- Turn the rotary knob to select the column »alarms« and press to confirm.
- Turn the rotary knob to select the line »HLM on« and press to confirm.

- Display (example):

The lung is kept open with constant airway pressure.

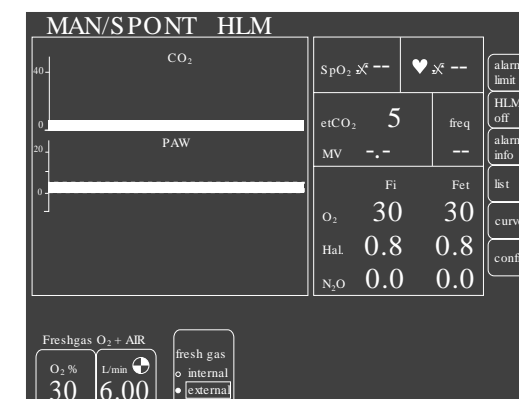

HLM alarm mode can be switched off at any time:

- Press the softkey »HLM off«.

In standby mode, the HLM alarm mode is automatically deactivated.