

# FORTUNA CLEAN BENCH 1200

## TECHNICAL DATA



### HIGHLIGHTS

- Compact design enabling trouble-free installation and relocation
- Sloped front
- Excellent light distribution
- Electrical sliding front window
- Easy window cleaning on both sides

For more information please visit [www.labogene.com](http://www.labogene.com)

Details	Note
Product family	FORTUNA CLEAN BENCH
Model	1200
Product type	Class 100 Clean Bench
Certificates	None
Compliance with	ISO 14644, EN 61010-1, EN 61000-6, EN 11201
E-catalogue classification (UNSPSC code)	41103504 Laminar flow cabinets or stations
	United Nations Product and Service Code. More information at <a href="http://gsidenmark.net.dynamicweb.dk">http://gsidenmark.net.dynamicweb.dk</a>

General specifications	Unit		Note
Sound pressure level at factory settings	dB(A)	≤47	According to EN 11201
Sound pressure level in Eco-Save mode	dB(A)	≤42	According to EN 11201
Down flow, air velocity	m/s	0,32±0,01	Factory setting
Light illuminance (flourescent tube)	Lux	> 2000	See sheet "Illuminance Calculation" for details
Front opening (height)	mm	350 (optionally 550)	Factory setting. Electrical variable front opening up to 550 mm
Filter construction in accordance with EN 1822-1		1-filter system, HEPA, at least Class H14	Type H14-HS Mikro SF-AL Filter frame B
Table top material		AISI 304 stainless steel	Optional AISI 316 stainless steel available
Table top max. total load	kg	100	Based on a realistic load in most conceivable cases. The actual load capacity is considerable higher
Side glass material		5 mm hardened glass w. 3 x ø22 mm holes	Float glass according to EN 12150-2. UV-C transmission 0%.
Front glass material		6 mm laminated safety glass	AGC glass type; "Stratobel + 2 x Planibel Clear". Nom. thickness 6,38 mm. UV-C transmission 0 %
Cabinet and back wall material/colour		Polyester coated steel/RAL 9016	Inver s.p.a. type 80454 "Epoxy polyester Tribo 45GL Bianco RAL 9016". Other RAL colours available upon request

Dimensions	Unit		Note
External dimensions with adjustable stand (Std. height) (DxWxH)	mm	797 x 1304 x 2033	See drawing for details. Can pass through a standard door opening size 0,9x2,1M. Stand is available as an option
Table top height with adjustable stand (Std. height)	mm	750	2 additional stand heights available as options
Table top height with elec. elevation stand	mm	750-1050	Available as an option
Work chamber dimensions (DxWxH)	mm	644x1200x700	
Net weight	kg	161	
Shipping Volume	m <sup>3</sup>	Approx. 2,9	

# FORTUNA CLEAN BENCH 1200

## TECHNICAL DATA

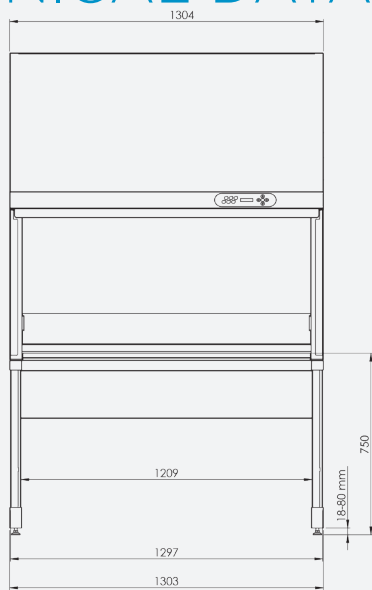

Front view, closed cover

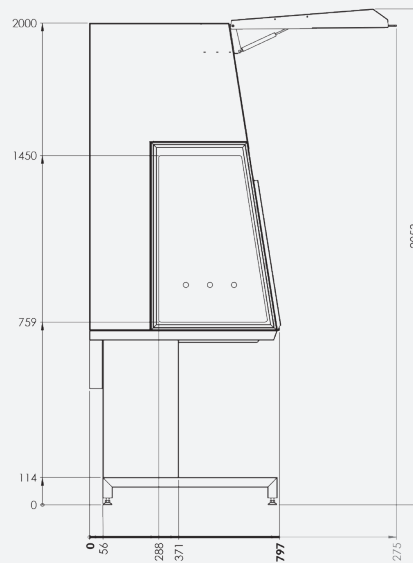

Side view, open cover

Electrical data	Unit		Note
Rated AC voltage/frequency	V/Hz	220-240/50-60	Other voltages available
Rated max. current (fuse)	A	10	
Power outlet(s) max. total current (fuse)	A	6,3	The sum of all power outlets
Typical power consumption excl. power outlets	VA/Watt	100/92	With LED tube
Typical power consumption in Eco-Save mode	VA/Watt	50/35	Lights off
Type of mains connection		3pin male AC power socket	Top mounted, left or right side. Cable connector type IEC320, C13

Additional available options	Unit		Note
Electrical elevation - Worktop height range	mm	745-1050	
LED dimmable light		Excellent neutral white light distribution 1500Lux/4000K	
UV-C sterilisation		Easy and fast decontamination	
Power outlets, pair, left & right side		Select between 9 different regional types	

LaboGene ApS is Certified according to EN/ISO 9001 UKAS  
 LaboGene ApS owns the copyright of this data sheet. Subject to technical changes.  
 Illustrations and photos may contain options and modifications not supplied as standard.

Revision date | rev. | version: February 2018 | 05 | FORTUNA CLEAN BENCH 1200.UK