

Sector Scanning Probe

EUP-S72

INSTRUCTION MANUAL

Notes for operators and responsible maintenance personnel

- ★ Please read through this Instruction Manual carefully prior to use.
- ★ Keep this Instruction Manual together with the system with care to make it available anytime.

 **Hitachi, Ltd.**

Tokyo , Japan

Q1E-EP1231-7

© Hitachi, Ltd. 2013,2017. All rights reserved.

 0123

Manufacturer:



Hitachi, Ltd.

2-16-1, Higashi-Ueno, Taito-ku,

Tokyo, 110-0015, Japan

+81-3-6284-3668

<http://www.hitachi.com/businesses/healthcare/index.html>

European

Representative:



Hitachi Medical Systems GmbH

Otto-von-Guericke-Ring 3 D-65205 Wiesbaden,

Germany

EU Importer:

Address:

Hitachi Medical Systems Europe Holding AG

Sumpfstrasse 13 CH-6300 Zug, Switzerland

Local Distributor:

About this manual

This instruction manual shall provide instructions for using, cleaning, disinfecting and/or sterilizing the HITACHI ultrasound probes. It also describes safety considerations, maintenance.

For instructions for operating the main unit, refer to the operation manual for it.

Before using the probe, thoroughly read this manual and keep this book for future reference.

If you have any questions concerning the manual, please contact a service support.

The following conventions are used throughout the manual to denote information of special emphasis.



WARNING: "Warning" is used to indicate the presence of a hazard which can cause severe personal injury, death, or substantial property damage if the warning is ignored.

CAUTION: "Caution" is used to indicate the presence of a hazard which will or can cause minor personal injury or property damage if the caution is ignored.

NOTICE: "Notice" is used to notify people of installation, operation, or maintenance information which is important, but not hazard related.











Graphical Symbols for Use in Labeling of Hitachi Ultrasound Probes

Some graphical symbols that are used in labeling of Hitachi Ultrasound Probes are compliant with EN980:2008 standard. Refer to the following table about the meanings of them.

Explanation of Symbol	Symbol	Descriptive Content
Manufacturer Company Name and Address		Hitachi, Ltd. 2-16-1, Higashi-Ueno, Taito-ku, Tokyo, 110-0015, Japan +81-3-6284-3668 http://www.hitachi.com/businesses/healthcare/index.html
Authorized Representative in The European Community		Hitachi Medical Systems GmbH Otto-von-Guericke-Ring 3 D-65205 Wiesbaden, Germany
Keep away from Sunlight		Store the probe in a cool, dustproof, dark and dry place and keep away from high temperature, high humidity and direct sunlight.

Definition of symbol

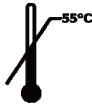
The following symbol is also used for HITACHI Ultrasound Probes.

Location	Symbol	Definition
Probe connector		This instrument complies with Directive 93/42/EEC relating to Medical Device and Directive 2011/65/EU relating to RoHS
Probe connector		IPX7 mark See section 1.5.
Probe connector		Type BF APPLIED PART
Probe connector		General warning sign
Probe connector		Warning; dangerous voltage
Probe connector		Caution; Biohazard
Probe connector		Follow the instruction manual to operate this instrument. If not avoided, may result in injury, property damage, or the equipment trouble.
Probe connector		STERRAD sterilization compatibility mark
Probe connector		Upper Limit of Temperature; The probes that are applicable to Ethylene Oxide Gas Sterilization use symbol of "Upper Limit of Temperature: 55 degrees".
Probe connector		Do not waste the instrument as general waste. Comply with a local regulation.
Probe connector	Rx Only	By prescription only. U.S. Federal Law restricts this device to sale on order of a physician only.

CONTENTS

Page

1	Introduction	1
	1.1 Features	1
	1.2 Principles of operation	1
	1.3 Intended Use	2
	1.4 Composition	2
	1.5 Construction	2
2	Inspection before Use	3
	2.1 Inspection for Appropriate Connection	3
	2.2 Inspection for Material Surface	3
3	Operation Procedure	4
4	Cleaning, Disinfection and Sterilization	5
	4.1 Point of use (Pre-cleaning)	8
	4.2 Containment and transportation	8
	4.3 Manual Cleaning and disinfection	8
	4.4 Drying	11
	4.5 Inspection	11
	4.6 Packaging	11
	4.7 Sterilization	12
	4.8 Storage	14
5	Maintenance and Safety Inspection	14
6	Safety Precautions	15
7	Specifications	16
	7.1 Probe	16
	7.2 Suppliers List	17
8	Disposal of the probe	18

1 Introduction

1.1 Features

The probe of model EUP-S72 is a phased array sector scanning type.

The acoustic output of this probe when connected to ultrasound scanner was measured according to the IEC60601-2-37 standard. The table of measured acoustic output data is contained in the operation manual of each ultrasound scanner.

This probe is categorized in class IIa according to Directive 93/42/EEC.

According to IEC60601-1 the probe is classified as type BF.

〈WARNING〉

Never use the probe for following applications.

- 1) Direct contact to the heart.
- 2) Biopsy to the heart.

1.2 Principles of operation

This probe and the ultrasound diagnostic scanner enable image diagnosis using ultrasonic waves. This system operates under the principles described below.

- 1) When an electric pulse signal is applied from the transmitter to the transducer of the probe, the transducer converts electric signals into mechanical vibration energy for emitting pulse-shaped ultrasonic waves into the body part, liquid or other medium contacting the transducer.
- 2) The emitted ultrasonic waves are reflected by boundaries with different acoustic characteristics (acoustic impedance) within the body.
- 3) The transducer is also used to receive reflected ultrasonic waves. The transducer vibrates mechanically due to the received ultrasonic waves and converts mechanical vibrations into electric energy. Electric signals are converted to shades of brightness by brightness modulation to obtain an image.

1.3 Intended Use

The Sector Scanning Probe EUP-S72 is designed for observation and diagnosis mainly of the following regions by connecting with the HITACHI ultrasound scanner.

- Pediatric

1.4 Composition

The probe components of the EUP-S72 are as follows:

- 1) Probe EUP-S72 1 piece
- 2) Instruction Manual 1 copy

〈 CAUTION 〉

Sterilization has not been made to the probe shipped from the factory.
Prior to use of it, be sure to clean, disinfect and sterilize it.

1.5 Construction

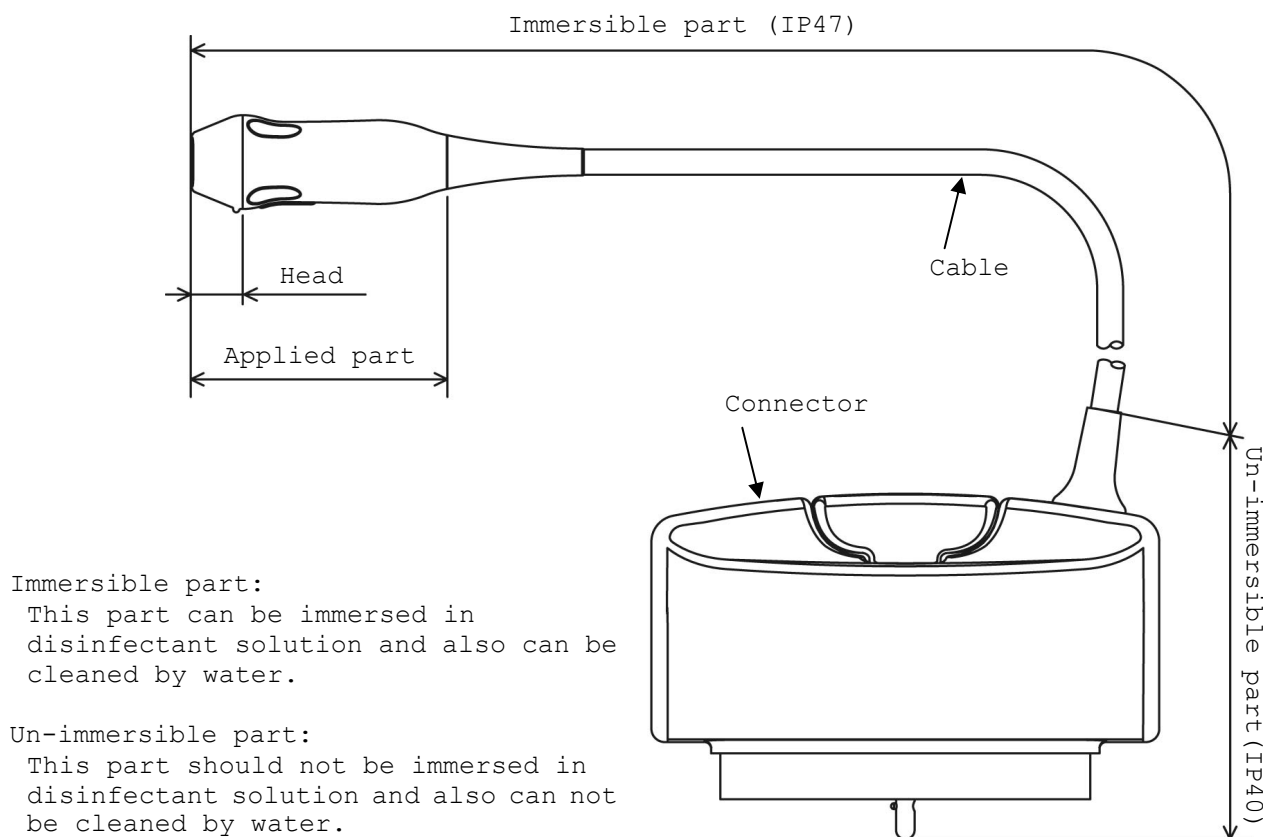

Fig. 1 External View

2 Inspection before Use

Prior to use, the probe must be carefully inspected that it is appropriate for use.

If not, do not use the probe and immediately contact a service support.

2.1 Inspection for appropriate connection

2.1.1 Check that the system is correctly operating.

Refer to the instruction manual for the main unit.

2.1.2 Do not attach or connect unauthorized devices nor instruments on the probe, such as unauthorized biopsy attachments.

2.2 Inspection of material surface

2.2.1 Visually check the surface of the probe head, housing and cable for any crack, scratch or denaturalization.

3 Operation Procedure

- 1) Confirm that the probe is cleaned, disinfected and sterilized.
- 2) Connect the probe, operate the main unit, and adjust the image according to the instructions given in the operation manual for the main unit.
- 3) Relationship between direction of the probe and the image is shown in Fig. 2. The right-left orientation mark on the image indicates the index mark on the probe.

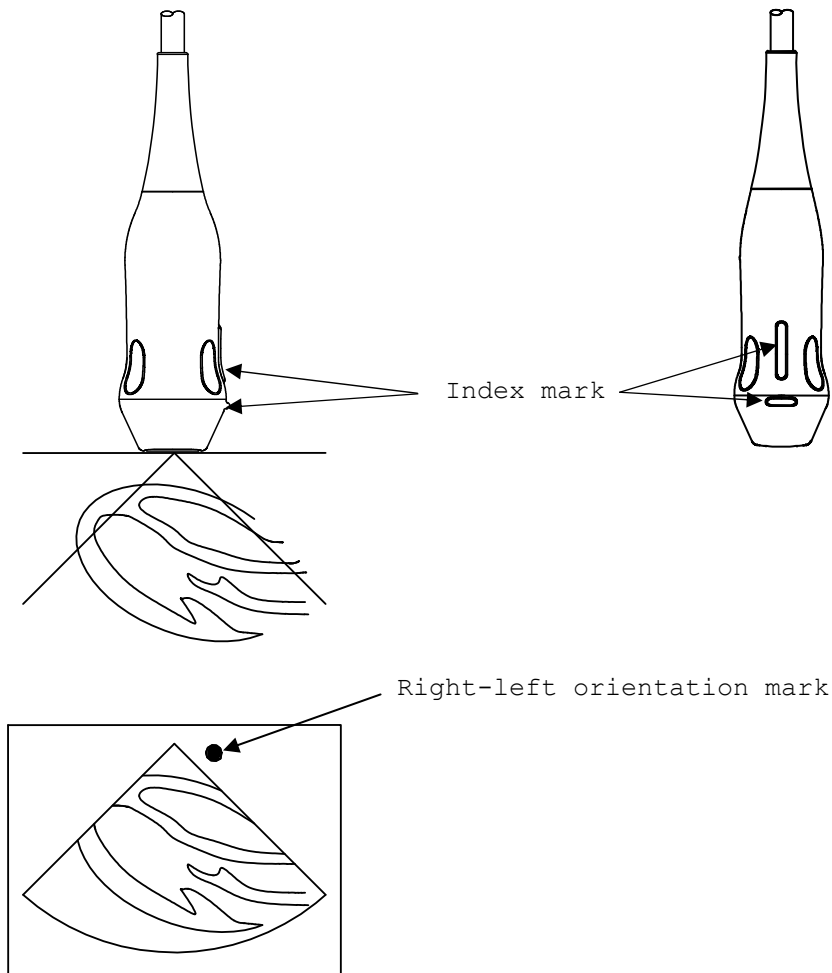

Fig. 2 Relationship between direction of the probe and Right-left orientation Mark

- 4) Use under sterile condition, protect the probe by using covers is recommended. Some Latex material may create allergic reaction. Please use allergy free material covers.
- 5) After the use of the probe, it should be cleaned and disinfected and sterilized, then store it in an adequate place.

4 Cleaning, Disinfection and Sterilization



The probe must be reprocessed after each use. Refer to the reprocessing instruction in this chapter.

WARNINGS	<ul style="list-style-type: none">- The probe is delivered unsterile. Prior to the first use, reprocess the probe.- Temperature should not exceed 60°C during reprocessing- Probe connector is not water resistant.
Limitations on reprocessing	The probe is not completely submersible. The immersible part is shown in Fig.1. The un-immersible part should be disinfected by wipe disinfection.
Transportation before using	The probe should be packed in a sterile pouch or container to transport from Central Sterile Supply Department (CSSD) to an operating room. Be careful not to damage the sterile pouch or container during transportation.

Levels of reprocessing requirements:

Depending on the application of the product and with regard to risk evaluation, the user has to classify the medical device according to the current Medical Device Directive for processing of medical devices as uncritical, semi-critical or critical. Supporting information concerning this topic is listed in the table below. The user is responsible for correct classification of the medical device.

Classification	Definition	Processing
uncritical	Application part only contacts intact and uninjured skin	Cleaning Disinfection
semicritical	Application part contacts mucosa (intracavitary application)	Cleaning Disinfection (Disinfectant with virucidal effect)
critical	Application part contacts intracorporeal tissue directly (operative application)	Cleaning Disinfection (Disinfectant with virucidal effect - minimum) Sterilization

According to the intended use, EUP-S72 is classified as uncritical.

The flowchart of the reprocessing process of this probe is as follows.

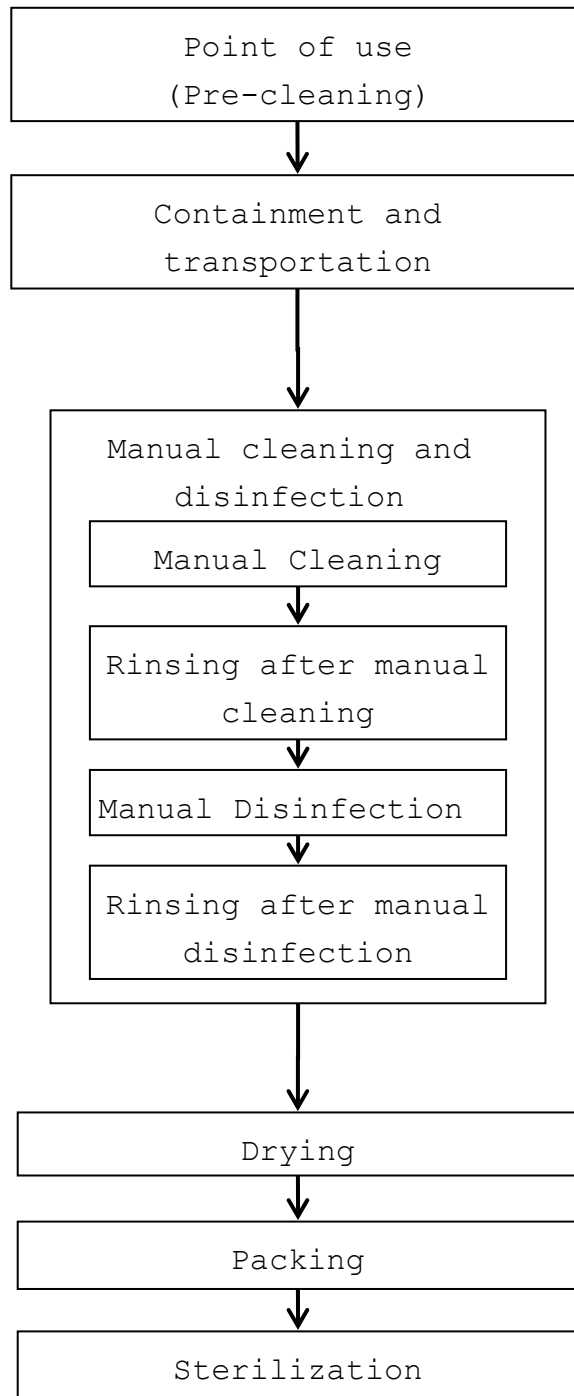

4.1 Point of use (Pre-cleaning)

Pre-cleaning should be done immediately after each use. The procedure is as follows:

Point of use
(Pre-cleaning)

- 1) Remove the protective cover.
- 2) Clean the probe of all patient's blood or fluid with running tap water until the surface of the probe looks visually clean.
- 3) Wipe the whole surface of the probe with gauze pad and remove superficial visible impurities and leavings of ultrasound jelly.

4.2 Containment and transportation

Putting the contaminated equipment into exclusive shock and damage proof container for transportation is recommended. It is recommended that instruments are reprocessed as soon as possible and not later than 4 hours after usage.

Containment and
transportation

4.3 Manual Cleaning and disinfection

Prepare following items before manual cleaning and disinfection:

- a) Detergent: Cidezyme (Johnson & Johnson, #2258) or another cleaning agent with approved material compatibility for this medical device
- b) Disinfectant: Cidex OPA (Johnson & Johnson, # 20391) or another disinfectant with approved material compatibility for this medical device
- c) Two tanks, one for cleaning and one for disinfection - optional:
1 additional tank for rinsing with deionized/tap water (sufficient size for immersion of the immersible part of the probe at full length)
- d) Soft, fluff free cloth or single use towel
- e) Personal protective equipment (gloves, water repellent protective skirt, face protection mask or protective glasses, see also instructions of the manufacturer for the detergent and the disinfectant)

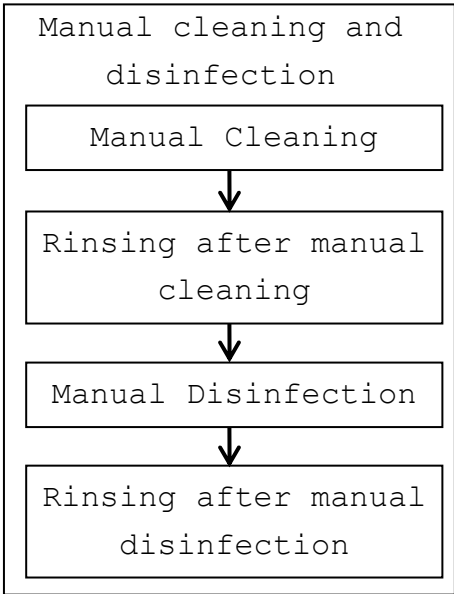

Manual Cleaning:

Prepare the detergent solution in a tank with cold water (please follow the instructions of the detergent manufacturer regarding application, dilution and contact time).

- 1) The temperature of the detergent solution should be between 15-30°C, concentration is 1.6%. Please note the minimum contact time of the detergent in the manufacturer's instruction. If a differing detergent is used, please also note the approved material compatibility for the medical device.
- 2) Immerse the immersible part of the probe without connector into the diluted detergent solution (see Fig. 3). Wipe the immersible part of the probe under the surface of the detergent solution with a soft cloth to remove all visible soil. Be sure that all grooves of the probe are implemented during the cleaning process.
- 3) The immersible part of the probe should be left in the detergent solution according to the specified contact time of the detergent manufacturer.
- 4) Wipe the un-immersible parts of the probe with a soft cloth dipped with the detergent solution.
- 5) Rinse the probe with running tap water for 1 minute. (alternatively: immerse the immersible part of the probe in a tray filled with deionized water/tap water (see Fig. 3) for 5 min.)
- 6) Visually check the outer surface of the probe for cleanness. If necessary, use magnifying glass for visually check. If there is still soil visible, repeat all above steps.

Manual disinfection:

- 1) Prepare the disinfectant solution in a tank with cold water (please follow the instructions of the disinfectant manufacturer regarding application, concentration, microbiological efficiency, service life and contact time).
- 2) Confirm the concentration of the disinfectant before immersing the probe. Although Cidex® OPA does not need to be diluted, it is recommended to use test strips to verify the concentration. The test strips can indicate whether or not the concentration is above the Minimum Effective Concentration (MEC). Please also note the expiration date of the test stripes. Temperature of disinfectant solution should be minimum 20°C. The minimum contact time is 5 minutes. If a different disinfectant is used, follow the manufacturer's instructions. Please also consider the material compatibility for the medical device.
- 3) Immerse the immersible part of the probe into the disinfectant (see Fig. 3). Set a clock to insure the recommended contact time which is 5 minutes.
- 4) Rinse the immersible part of the probe with deionized water for 1 minute. (alternatively: immerse the immersible part of the probe in a tray filled with deionized water (see Fig. 3) for 5 min.)
- 5) Visually check the outer surface of the probe for leavings of the disinfectant. If necessary, repeat the rinsing.

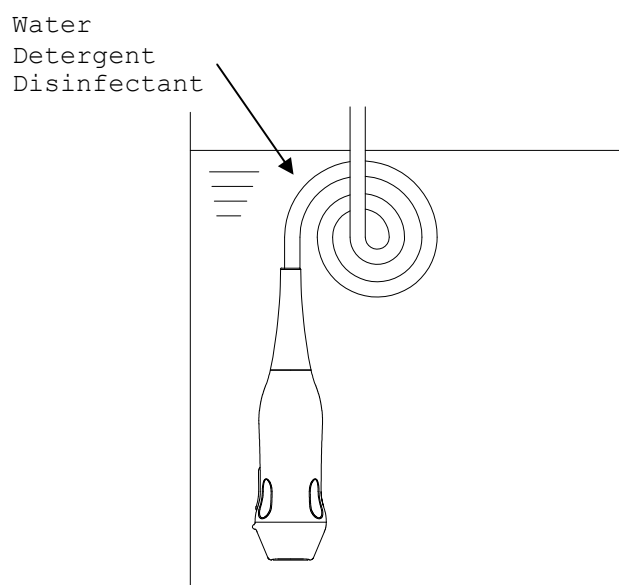

Fig. 3 Immersion of the Probe

4.4 Drying

- 1) Wipe the probe with a single-use, fluff-free wipe or towel to remove moisture from the surface of the probe.
- 2) Dry the probe naturally in an ambient temperature between 15-30°C for a minimum of 4 hours. Alternatively the equipment can be dried using a drying heater at a temperature of less than 60°C.

4.5 Inspection

Inspect the probe for any damage such as crack, scratch or deformation. Do not use it if any damage is found.

4.6 Packaging

Packaging

Pack the probe in a sterile barrier such as Polypropylene fleece or transparent package made from Polyethylene film and Tyvek®, and then place it into a tray. The tray should be also covered with a sterile barrier.

Additionally the probe can be placed on plastic mesh wires supplied for plasma sterilization and then packed as mentioned above.

The probe can be packed in a simple or double packing.

Please note that the size of a sterile barrier should be large enough to be able to pack the equipment leaving sufficient space to seal it completely.

A sterile barrier should be sealed by an appropriate sealing machine and it is important to confirm that the package is sealed completely. If the sealing is not complete, pack and reseal again.

4.7 Sterilization

The probe can be sterilized using either ethylen oxide gas (EtO) sterilization or plasma sterilization (see table below).

Follow the manufacturer's instructions of the sterilizer regarding usage, temperature and sterilization-time.

The sterilization method and operating conditions are as follows.

Sterilization Method	Condition
Plasma Sterilization: STERRAD® 50, 100S or 200 (*)	Short Cycle
Plasma Sterilization: Sterrad® NX or 100NX (*)	Standard cycle
ETO Sterilization	<ul style="list-style-type: none"> ➤ Gas Type: 10% EO/ 90% HCFC ➤ Temperature: 50-55°C ➤ Exposure Time: More than 120 minutes ➤ Pressurization: 162-200kPa Depressurization: 13-8kPa ➤ Relative humidity: 40-90% ➤ Aeration is minimum 12 hours

* STERRAD® systems are manufactured by "Johnson & Johnson"

⚠ WARNING

- 1) Before performing sterilization, check that the operation data of sterilizer are in conjunction with min. and max. data applicable for the probe.
- 2) Do not sterilize the probe by Steam Autoclaving. If you autoclave it, it suffers serious damage and will be not functional.

The packaging before sterilization is as follows.

- 1) Put the probe into TYVEK pouch.

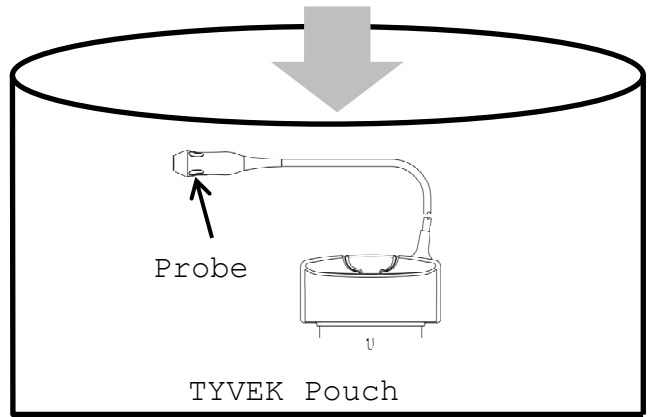

Fig. 4 Packaging in the pouch

- 2) Seal the TYVEK Pouch using a heat sealer. Ensure that the seal is complete.

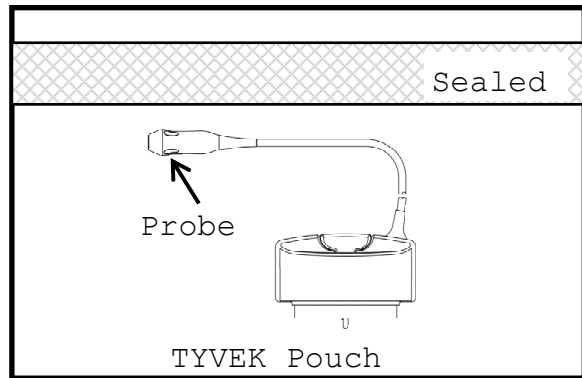

Fig. 5 Sealing

- 3) Put the sealed pouch into a tray or plastic mesh wire for sterilization.

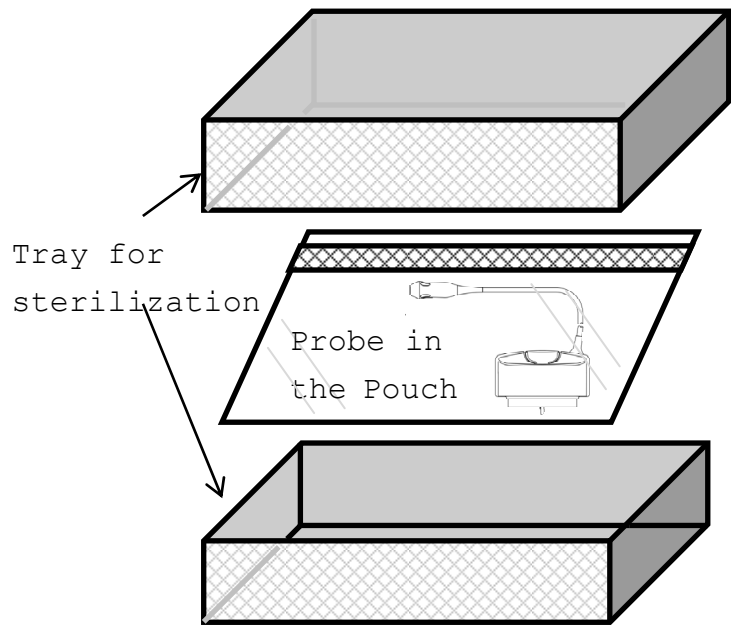

Fig. 6 Packaging in a tray

4.8 Storage



Store the equipment in a cool, dustproof, dry, and dark space to avoid high temperature, humidity and direct sunlight. Limitations for the time for sterilized equipment belong to package.

5 Maintenance and Safety Inspection



- 1) Daily visually check the surface of the probe head, housing, cable and connector for any crack, scratch or denaturalization. If you find damage, do not use the probe and immediately contact a service support.
- 2) After the use of the probe, it should be cleaned and disinfected and sterilized following "4. Cleaning , Disinfection and Sterilization", then store it in a cool and dark place avoid high temperature and humidity, direct sunlight.

6 Safety Precautions

〈WARNING〉

- Never use the probe if the probe head, housing or cable are cracked or damaged.
- Warning is case of using probe covers which latex is contained to.

The latex may cause such allergic reactions as itching, rubor, urticaria, swelling, fever, anhelation, wheezing, and depression of blood pressure, shock and so on.

For the patients suspected of latex allergy, do not use the latex-containing medical devices.

If you observe any of above mentioned symptoms in your patient during the operation, stop the use of the latex-containing medical devices immediately and take an appropriate treatment to the patient.

〈CAUTION〉

- By examination of an early pregnancy the exposure time shall be as short as possible. Start examination with acoustic output power set to L (Low).
- The probe connector is not water proof. Do not allow liquid to contact the connector.
- Do not drop, hit or bent the probe.
- Use only water, detergents and disinfectants in the suppliers list. Between uses store the probe holder off scanner.
- Under sterile condition use appropriate protection for probe and cable. Some Latex material may create allergic reactions.
- The probe is not delivered disinfected and sterilized.
- The acoustic lens of the probe is manufactured very thin and delicate to get the high resolution.

Therefore, in case of wiping off the ultrasound jelly or cleaning the surface of the acoustic lens, please use the soft cloth or tissue paper and handle with care.

7 Specifications

7.1 Probe

Type:	EUP-S72 Sector Scanning probe
Acoustic center frequency:	5MHz
Technology:	Phased Array Probe
Dimensions:	See Fig. 7.
Weight:	Approx. 0.66kg (Including cable and connector)
Scanning angle:	90°
Probe materials:	Biocompatible allergy free components
Acoustic output:	According to IEC60601-2-37 (See Main Unit manual)
Applicable systems:	Depending on production and upgrade status For detailed information, contact a service support.
Classification:	MDD classification IIa.
Cleaning:	Applicable detergents are listed in the supplier's list
Disinfection:	Applicable disinfectants are listed in the suppliers list
Sterilization	ETO gas sterilization Plasma sterilization
Operating conditions:	
Ambient temperature:	+10 - +35°C
Contact surface temperature: (Temperature of examinee)	max. 42°C
Relative humidity:	30 - 85% (subject to no condensation)
Storage conditions:	
Temperature:	-10 - +55°C
Relative humidity:	10 - 95% (subject to no condensation)

7.2 Suppliers List

The products listed below are seriously tested and approved for use with the Sector Scanning Probe EUP-S72.

Product name	manufacturer	purpose
Cidezyme	Johnson & Johnson	Enzymatic detergent
Meliseptol HBV-Tücher	Braun	Disinfectant
Incidin Liquid	Henkel Hygiene GmbH	Disinfectant
Incidur Spray	Henkel Hygiene GmbH	Disinfectant
STERANIOS 2%	ANIOS	Disinfectant
ANIOXYDE 1000	ANIOS	Disinfectant
Virkon S	ANTEC	Disinfectant
CIDEX	Johnson & Johnson	Disinfectant
CIDEX plus 28	Johnson & Johnson	Disinfectant
CIDEX OPA	Johnson & Johnson	Disinfectant
Tristel 1 Day	Tristel Company	Disinfectant
Tristel Multi-Shot	Tristel Company	Disinfectant
ALKACIDE	ALKAPHARM	Disinfectant
ALKAZYME	ALKAPHARM	Cleaner

Please contact your local distributor for a current version of the "Disinfectant/Sterilization Method Compatibility for Ultrasound Probe and Accessory List

8 Disposal of the probe

Recycle or dispose the equipment properly in compliance with your organizational rules and your local Law.

CAUTION

Before disposing the equipment, disinfect or take other infection-prevention measures.

Disposal of the equipment without taking the proper preventative measures can lead to infection.

Waste Electrical and Electronic Equipment (WEEE) Directive

The illustration on the right is required by the EU WEEE Directive to appear on all electrical and electronic equipment.

For proper disposal of this product in an EU nation, contact an EU office or agency and observe appropriate local and national regulations and laws.



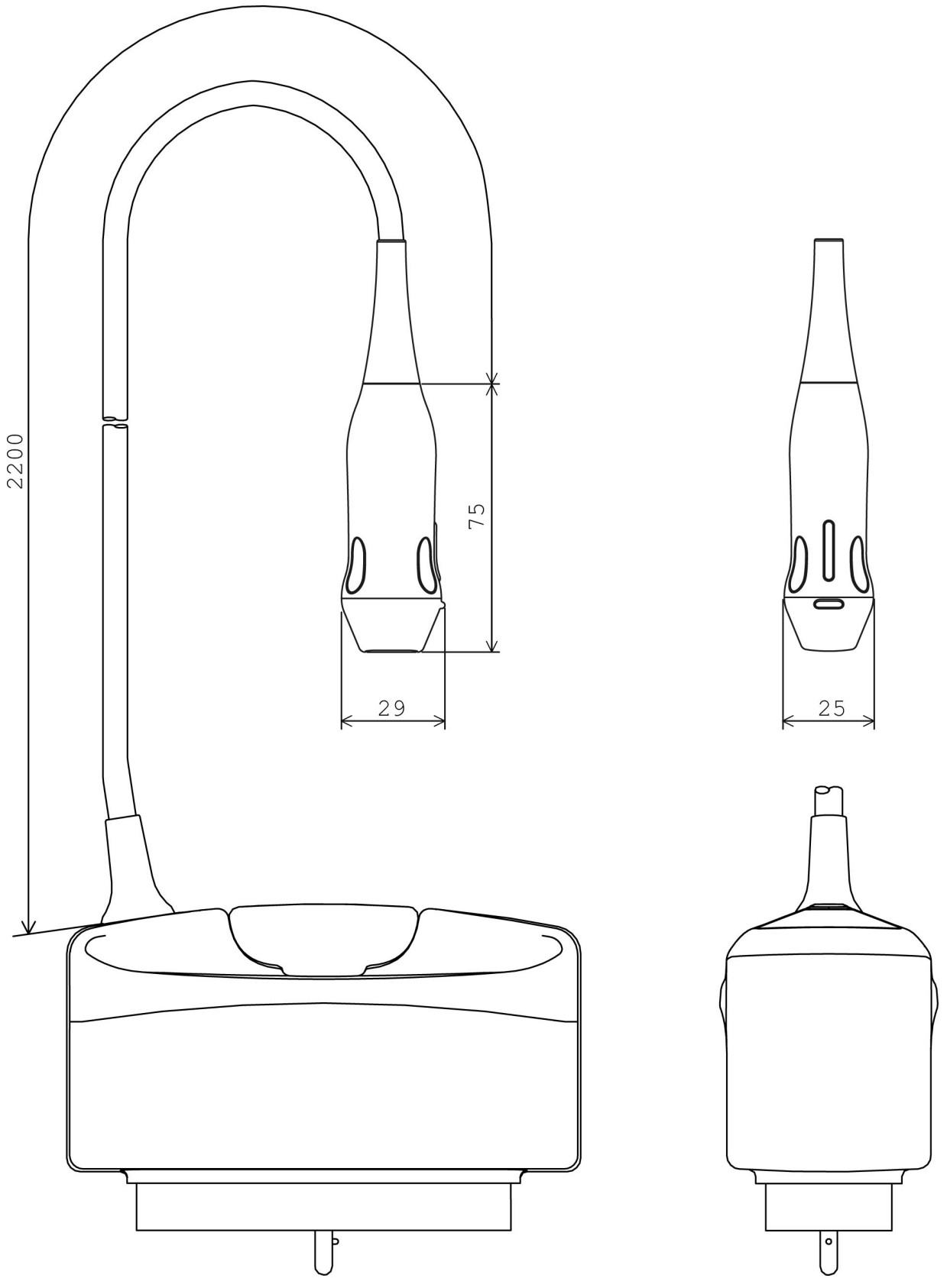

Unit: mm

Fig. 7 Dimensions