



Thermo Scientific LYNX Series Superspeed Centrifuges

Instruction Manual

50171087-b • 2025-08

Visit us online to register your warranty:

[thermofisher.com/labwarranty](https://www.thermofisher.com/labwarranty)

Contents

| | |
|--|-----------|
| Preface | 7 |
| Intended Use for Laboratory Use Centrifuges | 8 |
| Signal Words and Colors | 8 |
| Symbols Used in the Instruction Manual | 11 |
| Safety Instructions | 11 |
| 1. Transport and Set Up | 14 |
| 1.1. Unpacking | 14 |
| 1.2. Location | 14 |
| 1.3. Bolting Down the Centrifuge (optional) | 15 |
| 1.4. Transporting | 16 |
| 1.5. Setting Up | 16 |
| 1. 5. 1. Necessary Tools | 16 |
| 1.6. Leveling | 18 |
| 1.7. Mains Connection | 20 |
| 1.8. Storage | 21 |
| 1.9. Shipping | 21 |
| 2. Operation | 22 |
| 2.1. Control Panel | 22 |
| 2.2. Status | 22 |
| 2. 2. 1. Run Parameters | 23 |
| 2. 2. 2. Control and Configuration | 24 |
| 2.3. Power the Centrifuge On and Off | 25 |
| 2. 3. 1. How to Power On the Centrifuge | 25 |
| 2. 3. 2. How to Power Off the Centrifuge | 25 |
| 2.4. Open or Close the Centrifuge Door | 25 |
| 2. 4. 1. How to Open the Centrifuge Door | 25 |
| 2. 4. 2. How to Close the Centrifuge Door | 26 |
| 2. 4. 3. Centrifuge Door Gas Springs | 26 |
| 2.5. How to Operate a Rotor | 26 |
| 2. 5. 1. Before Installing a Rotor | 26 |
| 2. 5. 2. Proper Rotor Handling | 27 |
| 2. 5. 3. How to Install a Rotor | 27 |
| 2.6. Loading the Rotor | 28 |
| 2. 6. 1. Before Loading a Rotor | 28 |
| 2. 6. 2. Balance Loading | 28 |
| 2. 6. 3. After Loading a Rotor | 30 |
| 2.7. Entering Centrifugation Parameters | 30 |
| 2. 7. 1. Acceleration / Deceleration Profiles | 30 |
| 2. 7. 2. Preselect Speed / RCF-Value | 31 |
| 2. 7. 3. Preselect Run Time | 31 |
| 2. 7. 4. Preset Temperature | 32 |
| 2. 7. 5. Pre-Warm or Pre-Cool the Centrifuge | 33 |
| 2.8. Centrifugation | 33 |
| 2. 8. 1. Start Centrifugation | 34 |
| 2. 8. 2. Imbalance Indicator | 34 |
| 2. 8. 3. Stop Centrifugation | 34 |

| | |
|---|-----------|
| 2.9. Programmed Operation | 34 |
| 2. 9. 1. Start a Centrifuge Program | 34 |
| 2. 9. 2. Stop a Centrifuge Program | 35 |
| 2.10. Remove the Rotor | 35 |
| 2.11. Power Down the Centrifuge | 35 |
| 2.12. Aerosol-tight Applications | 35 |
| 2. 12. 1. Basic Principles | 35 |
| 2. 12. 2. Fill Level | 35 |
| 2. 12. 3. Aerosol-Tight Rotor Lids | 35 |
| Aerosol-tight Closure with ClickSeal | 36 |
| 2. 12. 4. Checking Aerosol Tightness | 37 |
| 2.13. Useful Features | 38 |
| 2. 13. 1. Rotor Landing Pad | 38 |
| 2. 13. 2. Rotor Lid Holder | 38 |
| 3. Maintenance and Care | 39 |
| 3.1. Cleaning Intervals | 39 |
| 3.2. Cleaning Basics | 39 |
| 3.3. Rotor Care and Inspection Accessories | 39 |
| 3. 3. 1. Routine Inspection of Your Rotor | 39 |
| 3. 3. 2. Metal Parts | 40 |
| 3. 3. 3. Slide Coated Rotors | 40 |
| 3. 3. 4. Plastic Parts | 40 |
| 3. 3. 5. O-Rings | 40 |
| 3. 3. 6. Cycles of Rotors and Buckets | 40 |
| 3.4. Cleaning | 41 |
| 3.5. Cleaning the Touchscreen | 41 |
| 3.6. Cleaning the Condenser Filter | 41 |
| 3.7. Disinfection | 42 |
| 3.8. Decontamination | 42 |
| 3.9. Autoclaving | 43 |
| 3.10. Maintenance | 43 |
| 3. 10. 1. Preventive Maintenance | 43 |
| 3. 10. 2. Service | 43 |
| 3.11. Lifetime | 44 |
| 3.12. Disposal | 44 |
| 4. Troubleshooting | 45 |
| 4.1. Mechanical Emergency Door Release | 45 |
| 4.2. Ice Formation | 46 |
| 4.3. Troubleshooting Guide | 46 |
| 4. 3. 1. Troubleshooting Centrifuge Issues | 46 |
| 4. 3. 2. Troubleshooting Rotor Issues | 47 |
| 4.4. Information for the Customer Service | 48 |
| 5. Technical Specifications | 49 |
| 5.1. Product Features | 49 |
| 5.2. Product Features and Materials Used | 49 |
| 5.3. List of Centrifuges | 50 |
| 5.4. List of Rotors | 50 |

| | |
|---|-----------|
| 5.5. Technical Specifications | 51 |
| 5.6. Directives, Standards and Guidelines | 53 |
| 5.7. Mains Supply | 54 |
| 5.8. Refrigerants | 54 |
| 6. Rotor Specifications..... | 55 |
| 6.1. BIOFlex HC | 55 |
| 6. 1. 1. Items Supplied | 55 |
| 6. 1. 2. Technical Data..... | 55 |
| 6. 1. 3. Rotor Performance Data | 55 |
| 6. 1. 4. Accessories..... | 56 |
| 6. 1. 5. Labware | 56 |
| 6. 1. 6. Biocontainment Certificate | 59 |
| 6.2. BIOFlex HS..... | 60 |
| 6. 2. 1. Items Supplied | 60 |
| 6. 2. 2. Technical Data..... | 60 |
| 6. 2. 3. Rotor Performance Data | 60 |
| 6. 2. 4. Accessories..... | 61 |
| 6. 2. 5. Labware | 61 |
| 6. 2. 6. Biocontainment Certificate | 63 |
| 6.3. TH13-6x50 | 64 |
| 6. 3. 1. Items Supplied | 64 |
| 6. 3. 2. Technical Data..... | 64 |
| 6. 3. 3. Rotor Performance Data | 64 |
| 6. 3. 4. Accessories..... | 65 |
| 6. 3. 5. Labware | 65 |
| 6. 3. 6. Biocontainment Certificate | 67 |
| 6.4. T29-8x50 | 68 |
| 6. 4. 1. Items Supplied | 68 |
| 6. 4. 2. Technical Data..... | 68 |
| 6. 4. 3. Rotor Performance Data | 68 |
| 6. 4. 4. Accessories..... | 69 |
| 6. 4. 5. Labware | 69 |
| 6. 4. 6. Biocontainment Certificate | 71 |
| 6.5. A21-24x15c | 72 |
| 6. 5. 1. Items Supplied | 72 |
| 6. 5. 2. Technical Data..... | 72 |
| 6. 5. 3. Rotor Performance Data | 72 |
| 6. 5. 4. Accessories..... | 73 |
| 6. 5. 5. Labware | 73 |
| 6. 5. 6. Biocontainment Certificate | 74 |
| 6.6. A22-24x16 | 75 |
| 6. 6. 1. Items Supplied | 75 |
| 6. 6. 2. Technical Data..... | 75 |
| 6. 6. 3. Rotor Performance Data | 75 |
| 6. 6. 4. Accessories..... | 76 |
| 6. 6. 5. Labware | 76 |
| 6. 6. 6. Biocontainment Certificate | 77 |
| 6.7. A23-6x100 | 78 |
| 6. 7. 1. Items Supplied | 78 |
| 6. 7. 2. Technical Data..... | 78 |
| 6. 7. 3. Rotor Performance Data | 78 |
| 6. 7. 4. Accessories..... | 79 |
| 6. 7. 5. Labware | 79 |

| | |
|---|------------|
| 6. 7. 6. Biocontainment Certificate | 81 |
| 6.8. A27-6x50 | 82 |
| 6. 8. 1. Items Supplied | 82 |
| 6. 8. 2. Technical Data | 82 |
| 6. 8. 3. Rotor Performance Data | 82 |
| 6. 8. 4. Accessories | 83 |
| 6. 8. 5. Labware | 83 |
| 6. 8. 6. Biocontainment Certificate | 85 |
| 6.9. A27-8x50 | 86 |
| 6. 9. 1. Items Supplied | 86 |
| 6. 9. 2. Technical Data | 86 |
| 6. 9. 3. Rotor Performance Data | 86 |
| 6. 9. 4. Accessories | 87 |
| 6. 9. 5. Labware | 87 |
| 6. 9. 6. Biocontainment Certificate | 89 |
| 6.10. Fiberlite F9-6x1000 LEX | 90 |
| 6. 10. 1. Items Supplied | 90 |
| 6. 10. 2. Technical Data | 90 |
| 6. 10. 3. Rotor Performance Data | 90 |
| 6. 10. 4. Labware | 91 |
| 6. 10. 5. Biocontainment Certificate | 94 |
| 6.11. Fiberlite F10-4x1000 LEX | 95 |
| 6. 11. 1. Items Supplied | 95 |
| 6. 11. 2. Technical Data | 95 |
| 6. 11. 3. Rotor Performance Data | 95 |
| 6. 11. 4. Labware | 96 |
| 6. 11. 5. Biocontainment Certificate | 99 |
| 6.12. Fiberlite F12-6x500 LEX | 100 |
| 6. 12. 1. Items Supplied | 100 |
| 6. 12. 2. Technical Data | 100 |
| 6. 12. 3. Rotor Performance Data | 100 |
| 6. 12. 4. Labware | 101 |
| 6. 12. 5. Biocontainment Certificate | 103 |
| 6.13. Fiberlite F14-6x250y | 104 |
| 6. 13. 1. Items Supplied | 104 |
| 6. 13. 2. Technical Data | 104 |
| 6. 13. 3. Rotor Performance Data | 104 |
| 6. 13. 4. Labware | 105 |
| 6. 13. 5. Biocontainment Certificate | 107 |
| 6.14. Fiberlite F14-14x50cy | 108 |
| 6. 14. 1. Items Supplied | 108 |
| 6. 14. 2. Technical Data | 108 |
| 6. 14. 3. Rotor Performance Data | 108 |
| 6. 14. 4. Labware | 108 |
| 6. 14. 5. Biocontainment Certificate | 110 |
| 6.15. Fiberlite F20-12x50 LEX | 111 |
| 6. 15. 1. Items Supplied | 111 |
| 6. 15. 2. Technical Data | 111 |
| 6. 15. 3. Rotor Performance Data | 111 |
| 6. 15. 4. Labware | 111 |
| 6. 15. 5. Biocontainment Certificate | 113 |
| 6.16. Fiberlite F21-8x50y | 114 |
| 6. 16. 1. Items Supplied | 114 |
| 6. 16. 2. Technical Data | 114 |

| | |
|--|------------|
| 6. 16. 3. Rotor Performance Data | 114 |
| 6. 16. 4. Labware | 115 |
| 6. 16. 5. Biocontainment Certificate | 116 |
| 6.17. Fiberlite F23-48x1.5. | 117 |
| 6. 17. 1. Items Supplied | 117 |
| 6. 17. 2. Technical Data. | 117 |
| 6. 17. 3. Rotor Performance Data | 117 |
| 6. 17. 4. Labware | 117 |
| 6.18. TCF-20 Continuous Flow and Zonal Rotors | 118 |
| Chemical Compatibility | 119 |

Preface

Before starting to use the centrifuge, read through these instructions for use carefully and follow the instructions.

The information contained in these instructions for use is the property of Thermo Fisher Scientific; it is prohibited to copy or pass on this information without explicit approval in writing by its owner.

Failure to follow the instructions and safety information in these instructions for use will result in the expiration of the seller's warranty.

Items Supplied

The centrifuges are supplied without a rotor. The items supplied with a rotor are listed in the specifications of each rotor. [→  55]







| Cat. No. | Item | Quantity |
|----------|---|----------|
| | Centrifuge | 1 |
| 75008580 | LYNX 4000 Superspeed Centrifuge, 200-240 V \pm 10%, 50/60 Hz, Single-phase | |
| 75008581 | LYNX 4000 Superspeed Centrifuge, 220(380)-240(415) V \pm 10%, 50/60 Hz, 3-phase | |
| 75008590 | LYNX 6000 Superspeed Centrifuge, 200-208 / 220-240 V \pm 10%, 50/60 Hz, Single-phase | |
| 75008591 | LYNX 6000 Superspeed Centrifuge, 220(380)-240(415) V \pm 10%, 50/60 Hz, 3-phase | |
| 75008592 | LYNX 6000 Superspeed Centrifuge, 220-240 V \pm 10%, 50/60 Hz, Single-phase | |
| | Power Supply Cable | 1 |
| | For single-phase units with 200-240 V | |
| 20190357 | IEC60309 32A-6h 3-pin blue, 200–250 V  | |
| 20190358 | NEMA 6-30P 30 A, 200–250 V  | |
| 20190359 | IEC60309 32A-6h 5-pin red (3P+N+PE), 200–240 V  | |
| 20190364 | NEMA L6-30P 30 A, 200–208 V  | |
| | For 3-phase units with 380, 400, 415 V | |
| 20190376 | IEC60309 16A-6h 5 pin red (3P+N+PE), 380 V–415 V  | |
| 20190369 | IEC60309 32A-6h 5 pin red (3P+N+PE), 380 V–415 V  | |
| 20280119 | Bubble Level | 1 |
| | Instruction Manual | 1 |
| | USB | 1 |

Table Preface–1: Items supplied

If any parts are missing, please contact the nearest Thermo Fisher Scientific representative.

Intended Use for Laboratory Use Centrifuges

This centrifuge is designed to separate sample mixtures of different densities like chemicals, environmental samples and other non-human body samples.

Signal Words and Colors



| Signal Word and Color | Degree of Hazard |
|--|---|
|  WARNING | Indicates a hazardous situation that, if not avoided, could result in death or serious injury. |
|  CAUTION | Indicates a hazardous situation that, if not avoided, could result in minor or moderate injury. |
| NOTICE | Indicates information considered important, but not hazard-related. |

Table Preface-2: Signal words and colors

Symbols Used on the Centrifuge and its Components



This symbol refers to general hazards. Observe the information contained in the instruction manual to keep yourself and your environment safe.

CAUTION means that material damage could occur.

WARNING means that injuries or material damage or contamination could occur.



This symbol refers to biological hazards.

Observe the information contained in the instruction manual to keep yourself and your environment safe.



This symbol refers to biological hazards.

Observe the information contained in the instruction manual to keep yourself and your environment safe.



This symbol refers to hazards from sharp items.

Observe the information contained in the instruction manual to keep yourself and your environment safe.



This symbol refers to hazards from closing mechanical parts.

Observe the information contained in the instruction manual to keep yourself and your environment safe.



This symbol refers to hazards from cold surfaces on the centrifuge.

Observe the information contained in the instruction manual to keep yourself and your environment safe.



efu.thermolisher.com

This symbol refers to information on hazards, described within the manual.

Observe the information contained in the instruction manual to keep yourself and your environment safe.



This symbol on rotors and components refers to information on hazards, described within the manual.

Observe the information contained in the instruction manual to keep yourself and your environment safe.



This symbol demands to disconnect mains before transporting or servicing the centrifuge.



This symbol shows the direction of rotation.



Indicates the device manufacturer.



Indicates the date when the device was manufactured.



Indicates the date after which the device is not to be used.



Indicates the manufacturer's batch code so that the batch or lot can be identified.



Indicates the manufacturer's catalogue number so that the device can be identified.



Indicates the manufacturer's serial number so that a specific device can be identified.



Indicates a device that is intended for one single use only.



Indicates the need for the user to consult the instructions for use.



The symbol indicating separate collection for EEE consists of the crossed-out wheeled bin.



Indicates CE conformity.



UK Conformity Assessed Mark: Indicates conformity with the applicable requirements for products sold within Great Britain.



Indicates conformity to Chinese environmental law.



Indicates that the centrifuge contains a fluid or gaseous medium under pressure.











Indicates conformity with Underwriter Laboratories (UL) requirements.

Table Preface-3: Symbols used on the Centrifuge and its Components

Symbols Used in the Instruction Manual

Observe the information contained in the instruction manual to keep yourself and your environment safe.

| | | | |
|---|--------------------------------------|---|---|
|  | General hazard |  | Electrical hazard |
|  | Biological hazard |  | Danger of cuts |
|  | Hazard caused by flammable materials |  | Risk of crushing |
|  | Hazard caused by hot surface. |  | Indicates information considered important, but not hazard-related. |

Safety Instructions



WARNING

Observe the safety instructions. Not following these instructions can cause damage like harm by mechanical impact, electrical shock, infection and loss of sample.

The centrifuge is to be used for its intended use only. Improper use can cause damages, contamination, and injuries with fatal consequences.

The centrifuge must be operated by trained personnel only.

It is the obligation of the operator to make sure, that the proper protective clothing is used. Mind the "Laboratory Biosafety Manual" of the World Health Organization (WHO) and the regulations in your country.

As safety zone maintain a clear radius of at least 30 cm around the centrifuge. Do not place any dangerous substances within this safety zone.

The clearance around the centrifuge is reduced when the centrifuge is bolted down (optional Seismic Bolt-down Kit 75006500).

[→  15]

Set up in a well-ventilated environment, on a horizontally leveled and rigid surface with adequate load-bearing capacity.

Do not modify the centrifuge and its accessories in any unauthorized way.

The centrifuge housing is not to be opened by the operator.

Thermo Fisher Scientific is not responsible for the process of human blood transfusion.

To ensure safe operation of this centrifuge regarding blood and blood components you have to follow the regulations in your country.



WARNING

Risk of damage due to incorrect power supply.

Make sure that the centrifuge is plugged only into a power outlet that has been properly grounded.



WARNING

The magnets built into the rotors can have a negative effect on active implants, such as cardiac pacemakers.

The magnets are mounted on the bottom of the rotor.

Always keep a distance of 20 cm between the rotor and the active implant, as the product generates permanent magnetic fields. The magnetic field strength at a distance of 20 cm is less than 0.1 mT, so there should be no interference.



WARNING

Risk from handling hazardous substances.

Especially when working with corrosive samples (salt solutions, acids, bases), the components and the centrifuge chamber have to be cleaned thoroughly.

Do not centrifuge explosive or flammable materials or substances.

The centrifuge is neither inert nor protected against explosion. Never use the centrifuge in an explosion-prone environment.

Do not centrifuge toxic or radioactive materials or any pathogenic micro-organisms without suitable safety precautions.

If centrifuging any hazardous materials mind the "Laboratory Biosafety Manual" of the World Health Organization (WHO) and any local regulations. When centrifuging microbiological samples from the Risk Group II (according to the "Laboratory Biosafety Manual" of the World Health Organization (WHO)), aerosol-tight biological seals have to be used. Look on the internet page of the World Health Organization (www.who.int) for the "Laboratory Biosafety Manual". For materials in a higher risk group, extra safety measures have to be taken.

If toxins or pathogenic substances have contaminated the centrifuge or its parts, appropriate disinfection measures have to be taken. [→ 42]

Extreme care should be taken with highly corrosive substances that can cause damage and impair the mechanical stability of the rotor. These should only be centrifuged in fully sealed tubes.

If a hazardous situation occurs, turn off the power supply to the centrifuge and leave the area immediately.



WARNING

Risk of contamination.

Potential contamination will not remain in the centrifuge while the device is operated.

Take appropriate protection measures to prevent spread of contaminations.

A centrifuge is not a closed containment.



WARNING

Serious injuries can occur if you touch a spinning rotor with your hands or tools.

Never open the centrifuge door until the rotor has come to a complete stop and this has been confirmed on the touchscreen.

The emergency door release may be used in emergencies only to recover the samples from the centrifuge, e.g. during a power failure. [→ 45]

Do not open the centrifuge, while it is running.

In any case of severe mechanical failure, such as rotor or bucket crash, the centrifuge is not aerosol-tight.

In case of rotor failure the centrifuge can be damaged. Vent and leave the room. Inform customer service.



WARNING

Risk of injuries from defective centrifuge door spring.

Make sure that the centrifuge door can be opened completely and that it will stay in its position.

Regularly check the centrifuge door springs for their proper function.

Do not operate the centrifuge with a defective door spring.

Let an authorized service technician replace defective centrifuge door springs.



WARNING

Safety can be impaired by wrong loading and worn accessories.

Use only a properly installed rotor. [→ 26]

Do not use rotors and accessories that show any signs of corrosion, cracks or removed protective coating. Contact customer service for further advice or inspections.

Use only with rotors that have been loaded properly.

Never overload the rotor.

Always balance the samples.

Use only rotors and components for this centrifuge that have been approved by Thermo Fisher Scientific. Exceptions to this rule are commercially available glass or plastic centrifuge labware, provided they have been designed to fit the rotor or the adapter cavities and are approved for the speed or the RCF value of the rotor.

Make sure the rotor is locked properly into place before operating the centrifuge.



WARNING

Physical harm caused by ignoring operative basics.

Never use the centrifuge if parts of its casing is damaged or missing.

Never start the centrifuge when the centrifuge door is open.

Do not move the centrifuge while it is running.

Do not lean on the centrifuge.

Do not place anything on top of the centrifuge during a run.

Implement measures that ensure that no one can approach the centrifuge for longer than absolutely necessary while it is running.



WARNING

The system contains refrigerant under high pressure.

Do not tamper with the system. It must be serviced by suitably qualified persons only.



CAUTION

Air friction may affect sample integrity.

Due to air friction the temperature of the rotor may rise significantly while the centrifuge is spinning.

Refrigerated units have limitations in cooling capabilities.

Displayed and set temperature can deviate from sample temperature. Sample temperature might exceed critical temperature of your application.



NOTICE

Protection capability may be impaired due to using unapproved accessories.

Use only accessories approved by Thermo Fisher Scientific for this centrifuge. Refer to the list of approved accessories. [→ 55].

Exceptions to this rule are commercially available glass or plastic centrifuge labware products, provided they have been designed to fit in the rotor or the adapter cavities and are approved for the speed or the RCF value of the rotor. Refrain from using any labware product if you are not entirely sure that the labware product is safe for the equipment. Use only labware products that will not damage the equipment. If in doubt contact the manufacturer of the labware product. If still in doubt, contact Thermo Fisher Scientific.



NOTICE

To shut down the centrifuge:

Press the STOP key to shut down the centrifuge.

Turn off the centrifuge at the power supply switch. The power supply plug must be freely accessible at all times.

Pull out the power supply plug or disconnect the power supply in an emergency



NOTICE

The centrifuge has a high-performance cooling system built in.

Cold surfaces may occur after each run at deep temperatures.

1. Transport and Set Up

The shipping box must be inspected upon delivery. When received, carefully examine for any shipping damage before unpacking. If damage is discovered, the delivering carrier must specify and sign for the damage on your copy of the delivery receipt.

Open the box carefully making certain that all parts are accounted for before packaging materials are discarded.

After unpacking, if damage is found, report it to the carrier and request a damage inspection.

Important: Failure to request an inspection of damage within a few days after receipt of shipment absolves the carrier from any liability for damage. You must call for a damage inspection.

NOTICE It is your responsibility to make sure that the centrifuge is set up properly.

1.1. Unpacking

- Check the centrifuge and the packaging for any shipping damage.
- Inform the shipping company and Thermo Fisher Scientific immediately if any damage is discovered.
- Use the list of items supplied when unpacking to verify that the complete unit has been received [→  7]. Do not discard packing materials until you have checked the list of items supplied for completeness against the contents of the shipping box.

1.2. Location

Operate the centrifuge only indoors.

The set up location must meet the following requirements:

- Allow for a safety zone of minimum 30 cm around the centrifuge. [→  15]
- Be at a safe distance to sources of strong electromagnetic radiation (e.g. unshielded intentional radio-frequency sources) that may cause interference to proper operation of the centrifuge. The electromagnetic environment should be evaluated prior to the operation of the device.
- Provide a stable, solid, and rigid ground plane that is able to hold the weight of the centrifuge and free of any resonance.
- Provide a completely even surface that allows a perfectly horizontal set-up of the centrifuge without the use of shims or similar material under the centrifuge.
- Be free from grease and dust.
- Be well ventilated at all times.
- Shelter the centrifuge, its accessories and the samples from heat and strong sunlight.

CAUTION UV rays reduce the stability of plastics. Do not subject the centrifuge, rotors and plastic accessories to direct sunlight.

- Allow free access to the mains power switch and power plug of the centrifuge at all times.
- Provide a safely grounded electrical power outlet that is well accessible and located outside of the safety zone.

WARNING Risk of impact. The centrifuge can crush objects and persons in a radius of 30 cm when a crash occurs. Make sure that the centrifuge stands on its feet and not on its castors. Keep a safety zone of 30 cm around the centrifuge for safe operation. Make sure that neither persons nor hazardous substances are within the safety zone while the centrifuge is spinning.

CAUTION Do not operate the centrifuge on carts or stand-alone shelving that could move during operation or are inadequately sized for the centrifuge.

CAUTION Centrifuges cause vibration. Do not store sensitive devices or hazardous objects and/or substances in the safety zone.

NOTICE The safety zone around the centrifuge can be reduced to 10 cm by bolting it down to the floor using the Seismic Bolt-down Kit (75006500) [→  15].

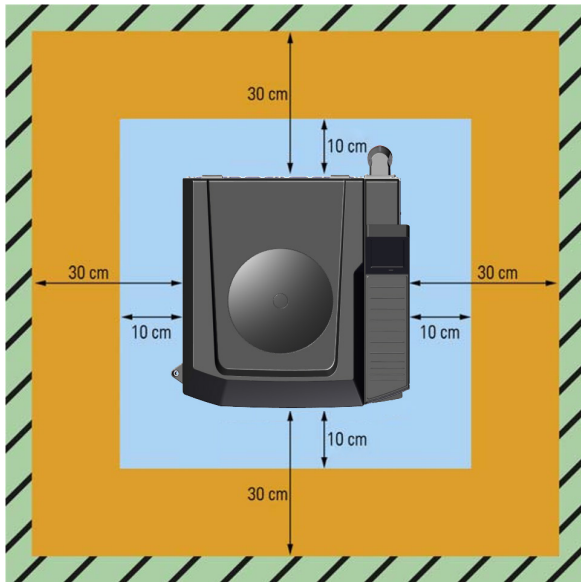





Figure 1: Safety zone

1.3. Bolting Down the Centrifuge (optional)

As a safety measure for earthquake areas or to comply with laboratory regulations, the centrifuge can be bolted down to the floor. If the centrifuge is bolted down to the floor the safety zone is reduced to 10 cm (Seismic Bolt-down Kit 75006500). Contact a service technician if you wish to bolt down the centrifuge.

1.4. Transporting

-  **WARNING** Never stand in the way of a runaway centrifuge to stop it.
 If the centrifuge is moved across a ramp or other slanted surface, it can get faster due to its own weight. A runaway centrifuge can crush persons in its path and inflict serious injuries.
-  **CAUTION** Always remove the rotor before you transport the centrifuge.
 If you do not remove the rotor you can damage the centrifuge drive or drive shaft.
-  **CAUTION** Do not push the centrifuge with your hands on the control panel. Doing so may damage the electronic circuit board of the control panel.

NOTICE Dispose of the centrifuge packaging.

NOTICE Assign a shipping company for the transport.
 Inform customer service about the transport.

- Use a forklift to lift a centrifuge that is fixed on a pallet.
- Impact can damage the centrifuge.
- Send the centrifuge upright and if possible in packaging.

1.5. Setting Up

1.5.1. Necessary Tools





| Graphic | Item | Quantity |
|---|--------------------------|----------|
|  | Wrench (24 mm) | 2 |
|  | Screwdriver (torque T20) | 1 |
|  | Cutter | 1 |



Table 1: Overview of necessary tools for setting up

NOTICE Due to its heavy weight, the centrifuge must be handled by at least two persons.

Proceed as follows to transport the centrifuge to its final location:

1. Use a forklift to transport the centrifuge upright on the pallet and with the centrifuge door closed.
2. Place the pallet with the centrifuge so that you have at least 2 m room on the back side of the centrifuge.
-  3. Remove all packaging material, such as shrink wrap foil and strapping.
4. Lift off the shipping carton and remove the inner padding from the centrifuge.

NOTICE Dispose of the centrifuge packaging.

5. Go to the rear side of the centrifuge, marked with two arrows and the LYNX label on the pallet.
 The arrows indicate the direction in which the centrifuge must be rolled off the pallet.
-  6. Loosen the eight screws (left and right in figure below) that secure the wooden stops to the pallet.
-  7. Loosen the two screws (center in figure below) that secure the ramps to the pallet.

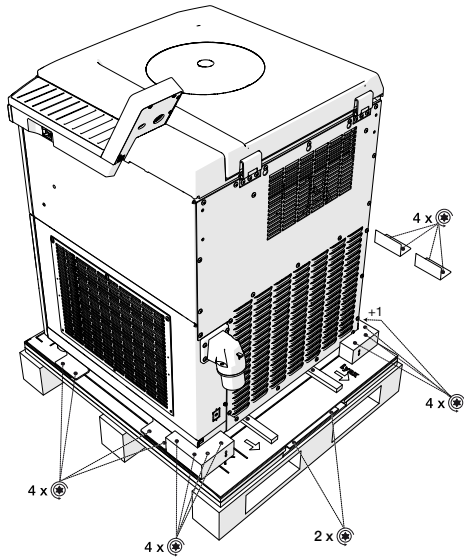

⊕ Torx screws

Figure 2: Screws securing wooden stops and ramps for transport

8. Remove the two wooden stops, the four lateral metal angle brackets and the ramps from the pallet, as shown below.

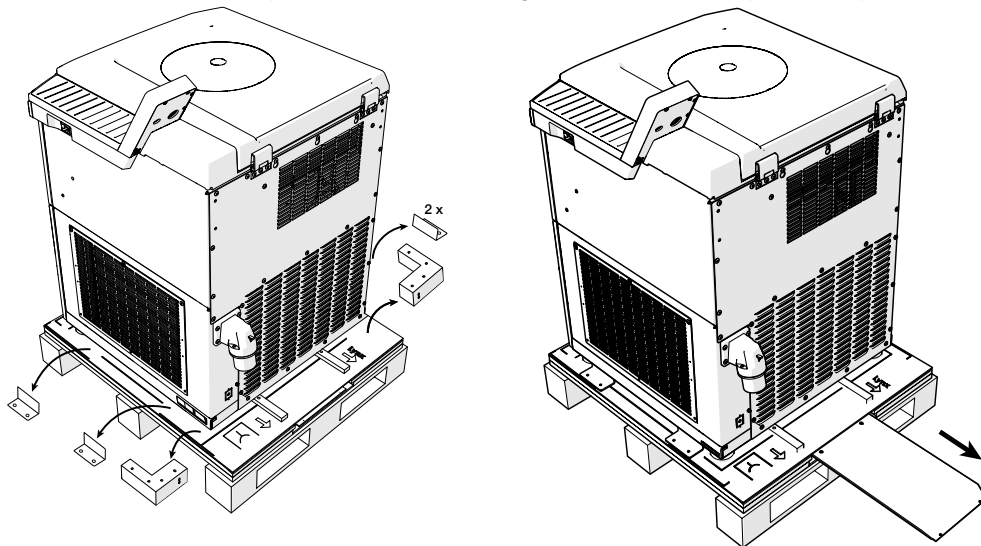

Figure 3: Removing the wooden stops, angle brackets and ramps

9. Fasten the ramps to the pallet using four of the leftover TORX screws you have just removed, as shown on the left side in the following illustration.
10. Place the two wooden stops under both ramps, as shown on the right side in the following illustration. This improves the stability of the ramps as you roll the centrifuge off the pallet.

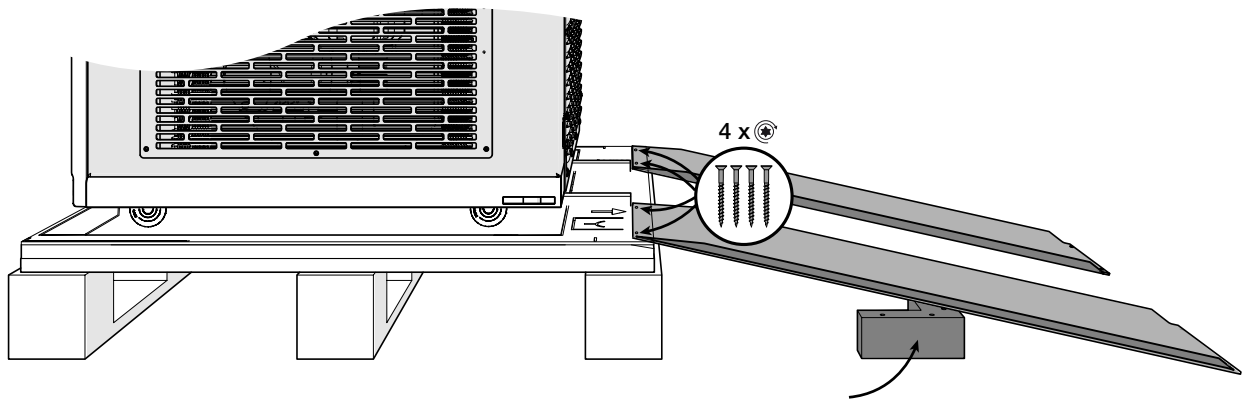

Figure 4: Fastening and supporting the ramps for roll-off

11. Align the four steering castors in parallel towards the ramps so the centrifuge cannot roll off the pallet sideways.
12. Make sure that all persons clear the path of the centrifuge off the ramp.
13. Inspect the path of the centrifuge for obstacles and remove, if any.
14. Working with two persons, carefully roll the centrifuge down the ramp and to its final position.

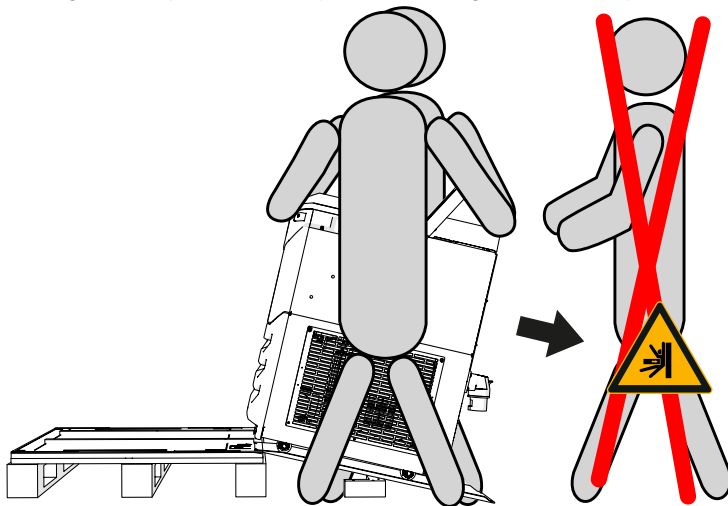

Figure 5: Rolling the centrifuge off the pallet with two persons

15. Move the centrifuge to its final position.
16. Before taking the centrifuge into service, make sure that it is fully leveled, that its four castors are retracted and that it rests solidly on all four leveling feet. This is explained in the following section.

1.6. Leveling

CAUTION Risk of failure and severe damage to unlevelled centrifuge. Failure to level the centrifuge correctly using the adjusting feet may result in imbalance and lead to severe damage to the spindle and drive. Leveling the centrifuge is mandatory before you use the device for the first time.

CAUTION Do not place shims or other objects under the centrifuge feet to level the centrifuge. Always use the adjusting feet for correcting levelness.

The centrifuge must be leveled before using it the first time.

The horizontal leveling of the centrifuge must be checked every time after moving it to a different location.

Do not move the centrifuge with a rotor attached to the centrifuge spindle as drive damage may result.

Level the centrifuge as follows:

1. Place the enclosed bubble level on the top surface of the Auto-Lock adapter in the rotor chamber.

2. Adjust the centrifuge feet until all four feet rest firmly on the floor and the bubble inside the level is completely inside the marked circle.
3. Turn the Auto-Lock adapter with the bubble level around a full 360° and check whether the bubble remains within the circle mark.
If 50 % of the bubble remains within the circle mark, the leveling of the centrifuge is acceptable. If more than 50 % of the bubble is outside of the circle mark, the centrifuge must be leveled again.



Figure 6: Position of bubble in bubble level

4. For securing the adjustment of the centrifuge feet, fasten both lock nuts.
5. Tighten the lower lock nut gently against the top side of the centrifuge foot and the upper lock nut upwards against the centrifuge housing.

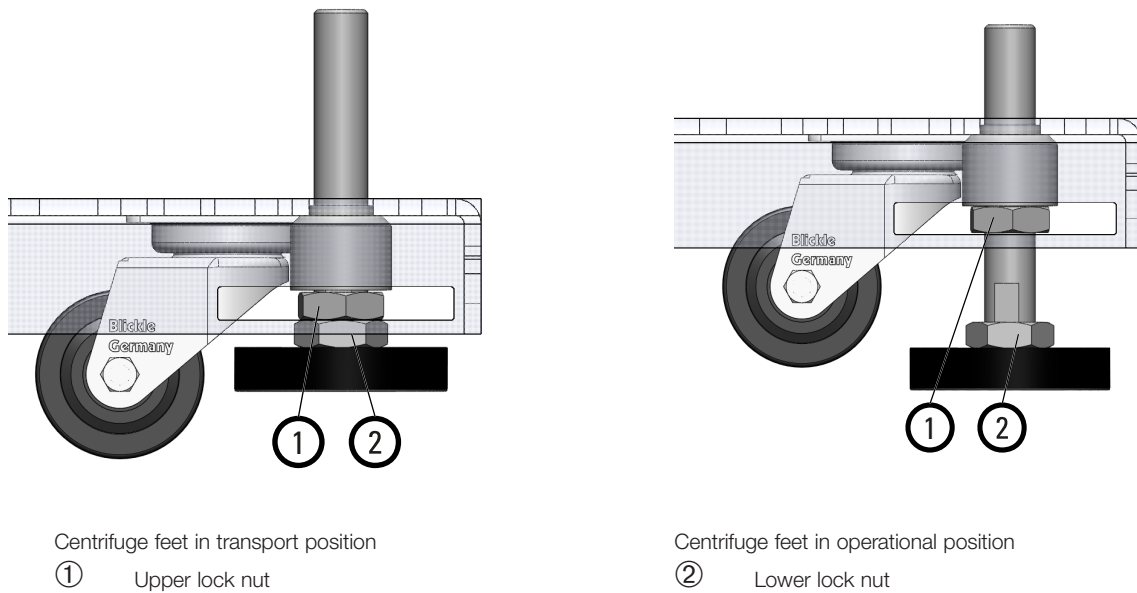

Centrifuge feet in transport position

① Upper lock nut

Centrifuge feet in operational position

② Lower lock nut

Figure 7: Securing the centrifuge feet

1.7. Mains Connection

CAUTION Use only the power supply cable supplied with the centrifuge. An improper power supply cable may damage the centrifuge.

NOTICE Connect the centrifuge to a grounded electrical power outlet only.

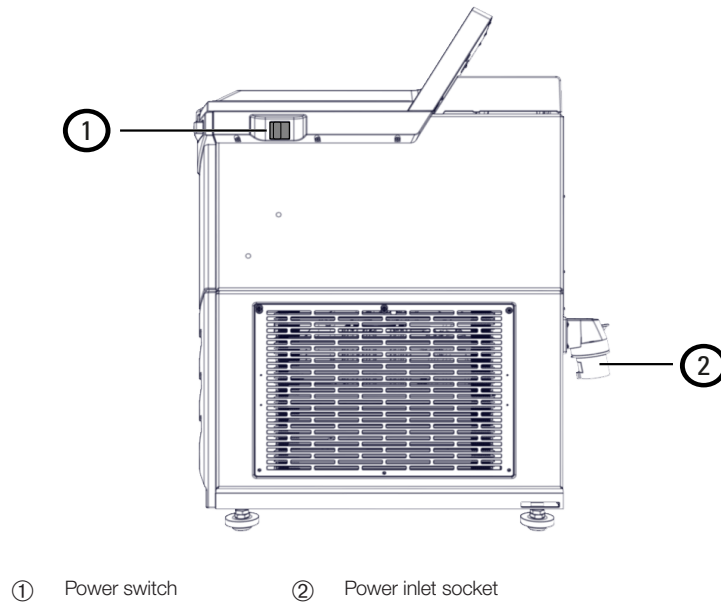

Figure 8: Power switch and power inlet socket

1. Turn off the power switch located on the right side (push the switch towards the front side of the centrifuge).
2. Check whether the power supply cable complies with the safety standards of your country.
3. Make sure that the voltage and frequency correspond to the figures on the rating plate.
4. Plug the appliance-side end of the power supply cable into the power inlet socket of the centrifuge.
5. Plug the free end of the power supply cable into a grounded electrical power outlet.

1.8. Storage

WARNING When you remove the centrifuge and accessories from use, clean and if necessary disinfect or decontaminate the full system. If you are not sure, consult Thermo Fisher Scientific customer service.

Before moving the centrifuge and its accessories to storage:

- Before storing the centrifuge and the accessories it must be clean and if necessary disinfected and decontaminated.
- The centrifuge, rotors and accessories have to be fully dry before storage.
- Keep the centrifuge in a clean, dust-free location.
- Keep the centrifuge on its centrifuge feet and not on its castors.
- Do not store the centrifuge in direct sunlight.

1.9. Shipping

WARNING Before shipping or disposing of centrifuges and accessories you have to clean and, if necessary, disinfect or decontaminate the entire system. If you are not sure how to prepare the centrifuge for shipping, consult with customer service.

- Before shipping the centrifuge:
 - » The centrifuge must be cleaned and decontaminated.
 - » You must confirm decontamination with a decontamination certificate.

2. Operation

2.1. Control Panel

The centrifuge has a touchscreen control panel that displays the operating controls and operational data of the centrifuge. The touchscreen allows for selecting and changing all parameters.

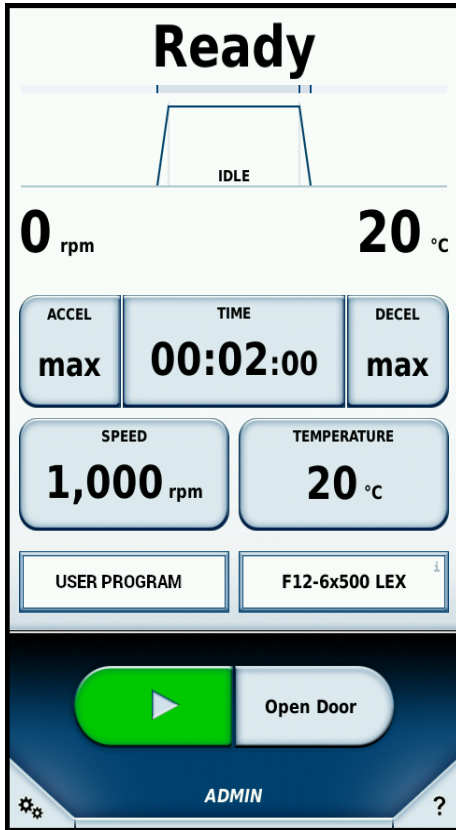

Figure 9: Touchscreen control panel

The main screen is divided into three sections:

- Status (top)
- Parameters (center)
- Control and Configuration (bottom)

2.2. Status

The top section of the touchscreen control panel displays the centrifuge status.

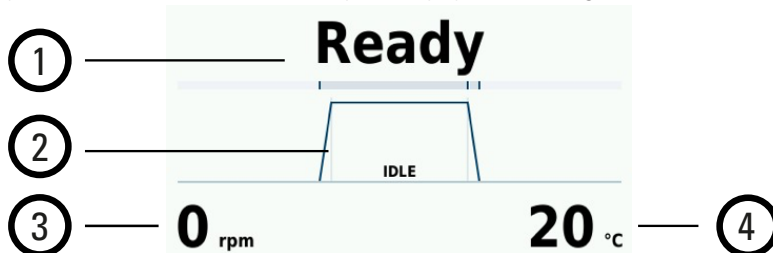

Figure 10: Touchscreen control panel - status area in idle mode

| Item | Description |
|------|--|
| 1 | Centrifuge status (see table below) |
| 2 | Graphical display of centrifugation progress The curve chart is divided into three sections: <ul style="list-style-type: none"> ▪ Acceleration ramp ▪ Centrifugation phase ▪ Deceleration ramp |
| 3 | Temperature: Shows the current sample temperature. |
| 4 | Speed: Shows the current speed of the rotor. |

While centrifugation is in progress, the remaining time is indicated, and a progress bar and animated curve chart show the current phase of the centrifugation run.

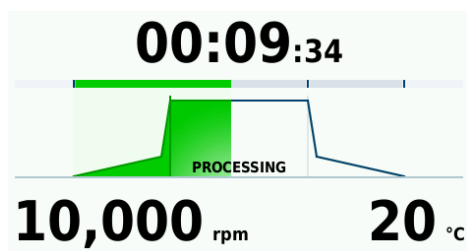

Figure 11: Touchscreen control panel - status area with centrifuge running

| Status | Description |
|----------------------------------|--|
| Timer (example: 00:02:00) | Shows remaining or elapsed time for the centrifugation process while the centrifuge is running, depending on selected mode. <ul style="list-style-type: none"> ▪ Time mode displays remaining time. ▪ Hold mode displays elapsed time. |
| Ready | Centrifugation can be started. |
| Door open | Centrifuge door is open. |
| Door blocked | Centrifuge door is blocked and cannot be opened. |
| Error | An error has occurred. |
| Canceled | Centrifugation has been stopped manually. |
| Complete | Centrifugation has been successfully completed. |
| Pretempering completed | Pretempering has been successfully completed. |
| No rotor | No rotor installed in the centrifuge. |
| Idle | Centrifuge is in idle operation. |
| Initialization | The centrifuge is being prepared for operation. |
| Timeout | Failure to reach the target temperature for pretempering in the defined time period. |

Table 2: Statuses displayed on touchscreen control panel

2. 2. 1. Run Parameters

The set points for centrifugation can be set in the parameters area of the touchscreen.

Tapping any of the buttons in the Parameters area opens a new window that lets you enter the appropriate set point value.

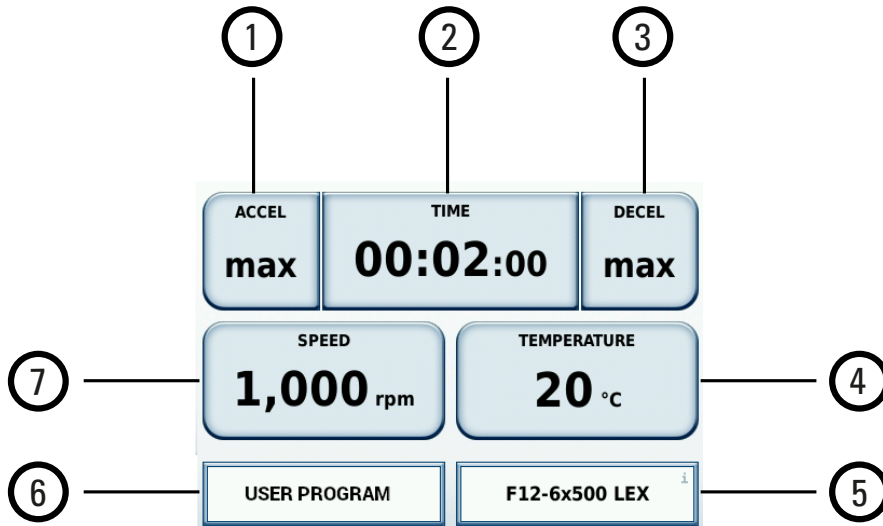

Figure 12: Touchscreen control panel - parameters area

| Item | Description |
|------|---|
| 1 | ACCEL: Select acceleration profile (Levels 1 through 9) |
| 2 | TIME: Set duration of centrifugation run and time mode |
| 3 | DECEL: Select deceleration profile (Levels 0 through 9) |
| 4 | TEMPERATURE: Set temperature for rotor chamber |
| 5 | Identifies rotor currently installed—for example, F12-6x500 LEX |
| 6 | PROGRAM: Select a user-defined centrifugation program. Shows the program used last or NO PROGRAM when no user programs exist yet. |
| 7 | SPEED: Set rotor speed in RPM or RCF. |

2. 2. 2. Control and Configuration

The Control and Configuration area of the touchscreen control panel lets you:

- start and stop centrifugation
- make general settings
- create and change centrifugation programs

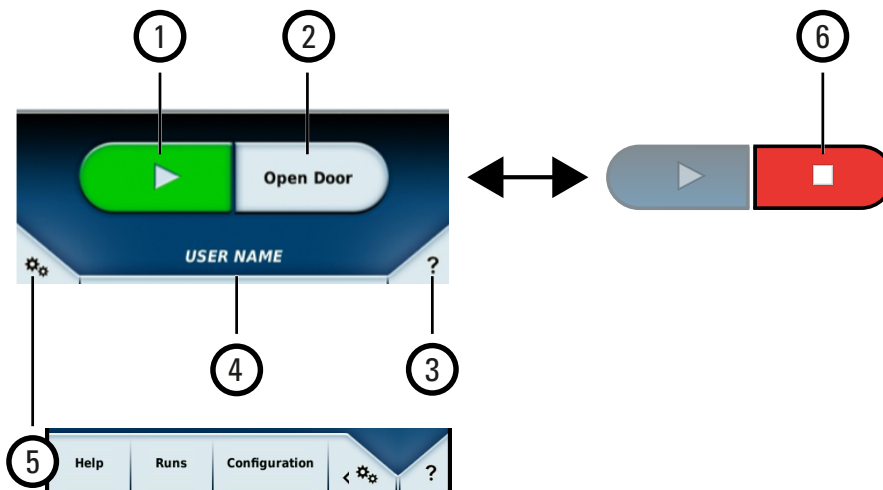

Figure 13: Touchscreen control panel - control and configuration area

| Item | Description |
|------|--|
| 1 | <p>Start button: Tap this button to start centrifugation.</p> <p>When the centrifuge starts running, the Start button is grayed out and inactive.</p> <p>Prerequisites: A rotor has been installed and identified, all parameters have been set correctly and the centrifuge door is closed.</p> |
| 2 | <p>Open Door button (centrifuge stopped): Tap this button to open the centrifuge door and access the rotor.</p> <p>When the centrifuge starts running, the Open Door button turns into the Stop button (item 6 below).</p> |
| 3 | <p>Tooltip button: Tap this button to enter Tooltip mode.</p> <p>Tooltip mode de-activates all touchscreen buttons and controls.</p> <p>If you tap a button in Tooltip mode, a help screen with instructions appears for that particular touchscreen item.</p> <p>Tap the Tooltip button one more time to exit Tooltip mode.</p> |
| 4 | <p>User Name field: This button lets you identify yourself as the controlling operator, which is required for specific applications.</p> |
| 5 | <p>Configuration button: Tap this button to display the configuration menu with advanced options.</p> |
| 6 | <p>Stop button (centrifuge running): Tap this button to stop the ongoing centrifugation run.</p> <p>When the rotor has come to a complete standstill, the Stop button turns back into the Open Door button (item 2 above).</p> |

2.3. Power the Centrifuge On and Off

2.3.1. How to Power On the Centrifuge

- Turn on the power switch on the right side of the centrifuge.
The device performs a self-check of its software.
- When the centrifuge is ready for service and the centrifuge door is closed the Status area of the touchscreen display reads **Ready**.

2.3.2. How to Power Off the Centrifuge

- Turn off the power switch on the right side of the centrifuge.

2.4. Open or Close the Centrifuge Door

Two gas springs open the centrifuge door when you tap the **Open Door** button on the touchscreen display.

2.4.1. How to Open the Centrifuge Door

CAUTION Open the centrifuge only after the rotor has stopped spinning, as indicated by 0 rpm on the display. The display shows the current speed also when an error condition exists. During a power failure the time until the rotor reaches standstill depends on the current speed. It may take up to 60 min for the rotor to reach standstill.

CAUTION Never reach into the centrifugation chamber while the rotor is spinning.

NOTICE The centrifuge door can only be opened when the centrifuge is switched on.

NOTICE When an error occurs—for example, a power failure, it is possible to open the centrifuge door using the mechanical door release.

[→  45]

WARNING Do not use the mechanical emergency door release as regular procedure to open the centrifuge. Use the mechanical emergency door release only if a malfunction or power failure occurs and only when you have made sure that the rotor has stopped spinning. [→  45]

To Open the Centrifuge Door

Tap the Open Door button on the touchscreen [→  22] or press the door unlock button located top right on the centrifuge front side, as shown below.



Figure 14: Door unlock button

2. 4. 2. How to Close the Centrifuge Door

CAUTION Risk of injury. Keep hands and objects well clear of the underside and sides of the centrifuge door while the door is closing.

CAUTION Do not reach into the gap between the centrifuge door and the housing. The centrifuge door is drawn shut automatically. Always place your hands on top of the centrifuge door.

NOTICE Do not slam the lid shut. Excessive force may cause damage or disrupt samples.

1. Ensure that the centrifuge platform is clear from objects.
2. Close the centrifuge door by pressing it down lightly in the middle or on both sides.

The centrifuge door is drawn shut automatically. The locking mechanism clicks and locks the door into place.

2. 4. 3. Centrifuge Door Gas Springs

The performance of a centrifuge door gas spring declines with the time and frequency of use. It is therefore good practice to check the proper function of the centrifuge door gas spring at regular intervals.

CAUTION Injuries may occur from a declining centrifuge door gas spring. If the pressure of the centrifuge door gas spring is not sufficient the centrifuge door will not remain open and can fall down.

How to check the function of the centrifuge door gas spring:

1. Open the centrifuge door and check if the centrifuge door stays open. The centrifuge door gas spring balances the weight of the centrifuge door and keeps the centrifuge door open. If the centrifuge door does not stay open, contact customer service.
2. Check if the centrifuge door gas spring is damaged. If the housing of the centrifuge door gas spring is damaged, contact customer service.

2.5. How to Operate a Rotor

NOTICE Operate the centrifuge only with rotors and accessories from the list with approved rotors. [→  50]

2. 5. 1. Before Installing a Rotor

CAUTION Do not install the rotor when the temperature difference between the shaft and the rotor hub is >20 °C. Otherwise the rotor might jam.

- Remove any dust, foreign objects or residue from the chamber, if necessary.
- Wipe the drive shaft and the rotor hub from the bottom side of the rotor with a clean cloth.
- Inspect the Auto-Lock adaptor and O-ring; both must be clean and undamaged.

2. 5. 2. Proper Rotor Handling

Improper installation can lead to failure so it is imperative to:

- Always make sure that the rotors are secured with the Auto-Lock feature.
- Ensure buckets are properly seated on their trunnions.
- Avoid dropping or striking the rotor against a hard surface.
- Avoid putting anything inside the rotor that could scratch or nick the surface.
- Ensure that all tubes, bottles and adapters are being used within their specified limits and according to the manufacturer's directions.

CAUTION Tube or bottle failures during centrifugation can result in minor to severe damage to rotors and centrifuges.

2. 5. 3. How to Install a Rotor

All rotors:

1. Tap the **Open Door** button on the touchscreen to open the centrifuge door. [→  24]
2. Place the rotor over the drive shaft and let it slide down slowly.
The rotor clicks into place automatically.

Swinging bucket rotors:

3. Make sure that the rotor is properly installed by lifting it slightly at its handle. If the rotor can be pulled up, then it must be reclamped to the drive shaft.
4. Make sure the rotor spins freely by turning it manually.
5. Make sure that a full complement of buckets is installed before operating the rotor. [→  29]

Rotors with lids:

6. Put the rotor lid on the rotor.
7. Make sure the rotor lid is accurately centered on the rotor.
8. Rotor lids with knob: Turn the rotor knob clockwise to close the rotor. (Counter-clockwise opens the rotor.)

NOTICE There is no need to press the Auto-Lock button to close or open the rotor.

9. Make sure that the rotor is properly installed by lifting it slightly at its handle. If the rotor can be pulled up, then it must be reclamped to the drive shaft.
10. Make sure the rotor spins freely by turning it manually.

All rotors:

11. Close the centrifuge door.

Supplementary Information

WARNING If the rotor cannot be properly locked in place after several attempts, then the Auto-Lock is defective and you are not permitted to operate the rotor. Check for any damage to the rotor: Damaged rotors must not be used. Keep the drive shaft area of the rotor clear of objects.

CAUTION Risk of burning on hot surfaces. When installing or removing a rotor you may accidentally touch the spindle or motor surface. The centrifuge spindle and the motor may be hot (>55 °C). Be aware of this risk and proceed carefully when you change a rotor after a run or wait until the motor has cooled down.

CAUTION Do not force the rotor onto the drive shaft. If the rotor is very light, it may be necessary to carefully push it onto the drive shaft.

CAUTION Make sure that the rotor is properly locked on the drive shaft before each use by lifting it at its handle.

CAUTION Unapproved or incorrectly combined rotors and accessories can cause serious damage to the centrifuge.

NOTICE Make sure that all components are safely fixed before you carry a rotor.

Use only approved rotors listed in this manual. [→  50] Operate the centrifuge only with rotors and accessories from that list. The centrifuge is equipped with a Thermo Scientific™ Auto-Lock™ locking feature that automatically locks the rotor to the drive shaft.

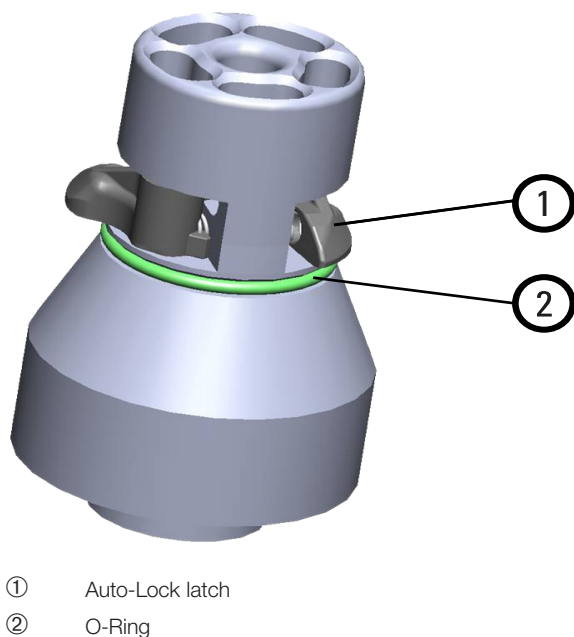



Figure 15: Auto-Lock adapter

Aerosol-tight Rotors

WARNING For aerosol-tight applications, be sure to check all seals before starting the centrifuge. Please refer to the section on aerosol-tight lids for more details and instructions. [→  35]

When using an aerosol tight lid the rotor can be removed with the lid closed. This is to protect you and the samples.

2.6. Loading the Rotor

2.6.1. Before Loading a Rotor

CAUTION Always use identical bucket types in opposite positions. Make sure that opposite buckets are of the same weight class, if a weight class is labeled on the buckets.

CAUTION Tubes may open and break during centrifugation because they do not fit properly into the cavities. Contamination may occur. Make sure that the length and width of the tubes are fitting into the adapter and cavities. Do not use tubes that are too short or too thick for the adapter and the cavities.

Before loading a rotor:

1. Inspect the rotor and all accessory parts for damage, such as cracks, scratches, or traces of corrosion.
2. Inspect the centrifugation chamber, drive shaft and Auto-Lock adapter for damage, such as cracks, scratches, or traces of corrosion.
3. Check the suitability of the rotor and other accessories used against the Chemical Compatibility Chart. [→  119]
4. Make sure that tubes or bottles fit in the rotor.

2.6.2. Balance Loading

Load the compartments evenly. Balance opposite loads.

When using swinging bucket rotors mind the following in addition:

- Weigh the bucket content (adapter and tube). Make sure you do not exceed the maximum compartment load nor the weight difference limit for adjacent buckets if there is one for the rotor.
- Make sure you install a full complement of buckets in all bucket slots if you are using a swinging bucket rotor.
- Make sure you install an identical bucket type in opposite positions.

If in doubt, contact customer service.

Correct Loading ✓

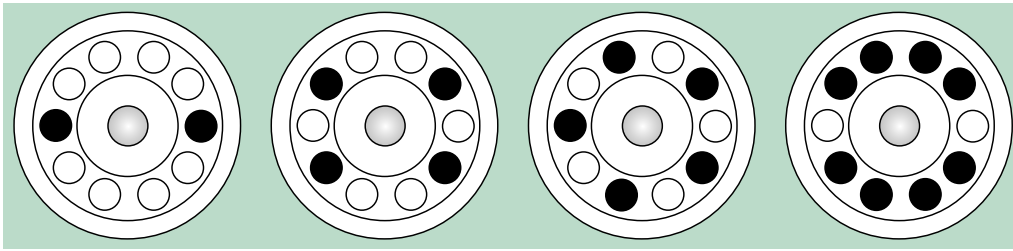

Figure 16: Correct loading examples for fixed angle rotors (simplified top view)

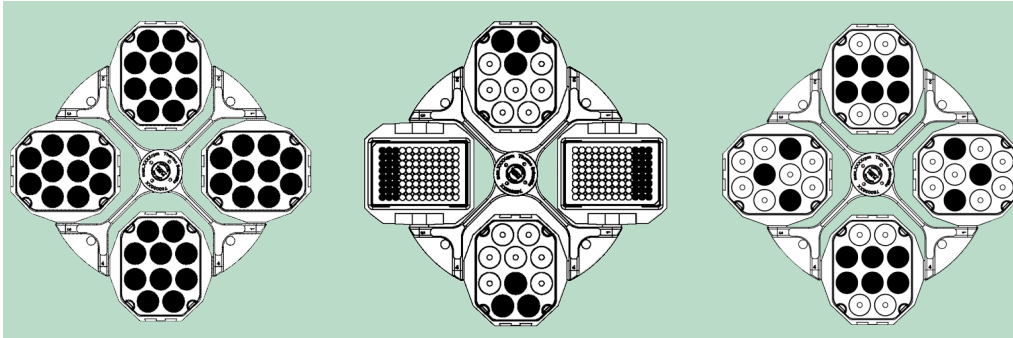

Figure 17: Correct loading examples for swinging bucket rotors (simplified top view)

Incorrect Loading ✗

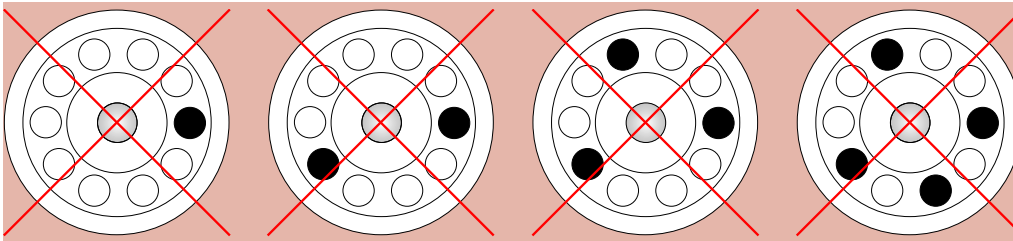

Figure 18: Incorrect loading examples for fixed angle rotors (simplified top view)

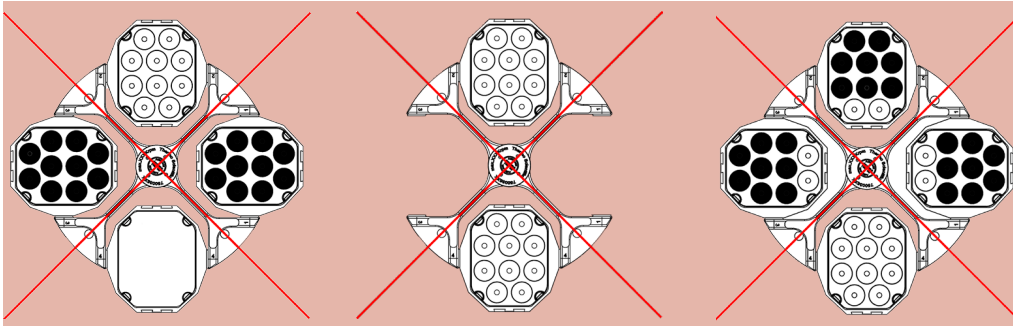

Figure 19: Incorrect loading examples for swinging bucket rotors (simplified top view)

Maximum Loading

Each rotor is designed to run with its maximum load at maximum speed. The safety system of the centrifuge requires that the rotor is not overloaded.

The rotors are designed to work with substance mixtures with a density of up to 1.2 g/ml. If the admissible maximum load is exceeded, the following steps need to be taken:

- Reduce the fill level.
- Reduce the speed.

Use the following formula to calculate the maximum admissible speed for a given load:

$$n_{\text{adm}} = n_{\text{max}} \sqrt{\frac{w_{\text{max}}}{w_{\text{app}}}}$$

n_{adm} = admissible maximum application speed

n_{max} = maximum rated speed

w_{max} = maximum rated load

w_{app} = applied load

RCF Value Explained

The relative centrifugal force (RCF) is given as a multiple of the force of gravity (g). It is a unitless numerical value that is used to compare the separation or sedimentation capacity of various centrifuges, since it is independent of the type of device. Only the centrifuging radius and the speed are used for calculation:

$$\text{RCF} = 11,18 \times \left(\frac{n}{1000} \right)^2 \times r$$

r = centrifuging radius in cm

n = rotational speed in rpm

The maximum RCF value is related to the maximum radius of the tube opening.

Remember that this value is reduced depending on the tubes, buckets and adapters used.

This can be accounted for in the calculation above if required.

Use of Tubes and Consumables

Make sure that the tubes and bottles used in the centrifuge are:

- specified for the rotor type, rated to or above the selected RCF to be spun at,
- never used below their minimum fill volume and never above their maximum fill volume,
- not used above their design life (age or number of runs),
- undamaged,
- fitting well into the cavities.

Please refer to manufacturers' data sheets for further information.

2. 6. 3. After Loading a Rotor

When you are done loading:

- make sure that the tubes or bottles do not touch the rotor lid or bucket caps,
- check whether buckets or microplate carriers can swing freely by moving them carefully with your hand.

2.7. Entering Centrifugation Parameters

The configuration parameters you enter are available whenever you power up the centrifuge.

2. 7. 1. Acceleration / Deceleration Profiles

There are 9 curves (1 through 9) for acceleration and 10 for deceleration (0 through 9).

The acceleration / deceleration profile can be selected in the Parameters area of the touchscreen control panel.

Profile 1 has the lowest number and lowest curve slope (labeled min), while profile 9 has the steepest curve slope (labeled max).

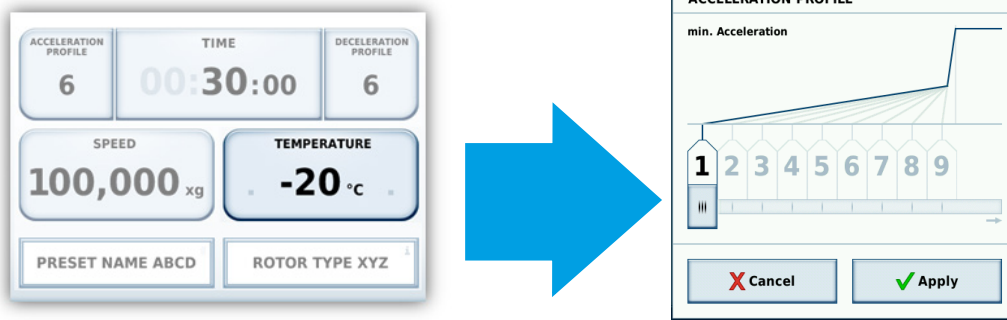

Figure 20: Choosing an acceleration or deceleration profile

Choose an acceleration or deceleration profile:

1. Tap the **ACCEL** or **DECEL** field to open a selection dialog.
2. Tap the number of the desired profile or drag the slider across the profile numbers.
3. Select **Apply** to confirm your selection for the next run.

2. 7. 2. Preselect Speed / RCF-Value

Preselect speed and choose whether you want to set centrifuge speed based on RPM (revolutions per minute) or RCF (Relative Centrifugal Force [→ ⓘ 30]):

1. Tap the **SPEED** field.
The SPEED dialog appears.

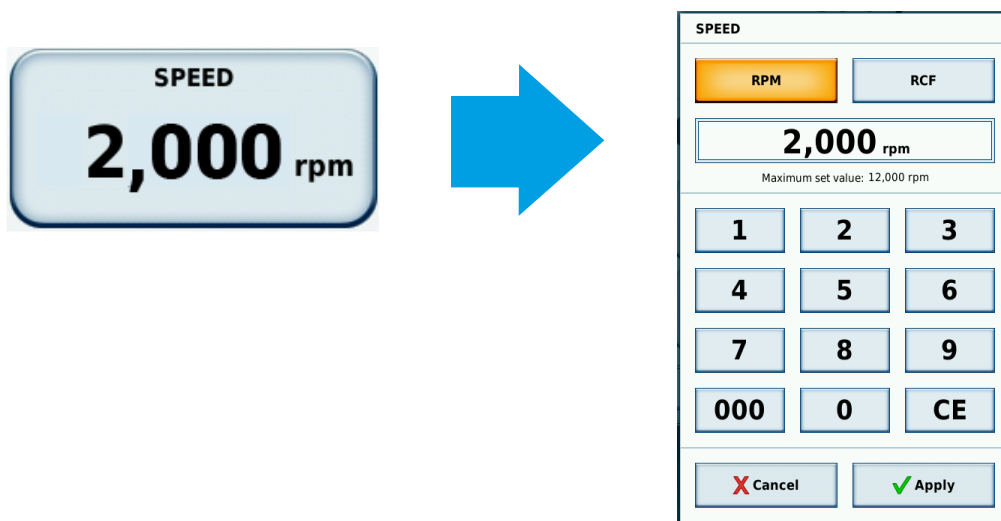

Figure 21: Dialog for speed and RPM/RCF value

2. Tap **RPM** or **RCF**, depending on whether you wish to run the centrifuge in RPM or RCF mode.
The selected format is highlighted in yellow.
3. Enter the desired value using the numeric keypad.
The digits appear in the order in which they are entered.
4. Tap **Apply** to confirm your entry.

NOTICE Entering an out-of-range speed or RCF-value produces a SPEED VALUE INVALID message, showing the limit that would be exceeded.

2. 7. 3. Preselect Run Time

Preselect the run time you wish to set as the default value:

1. Tap the **TIME** field.

The TIME dialog appears.

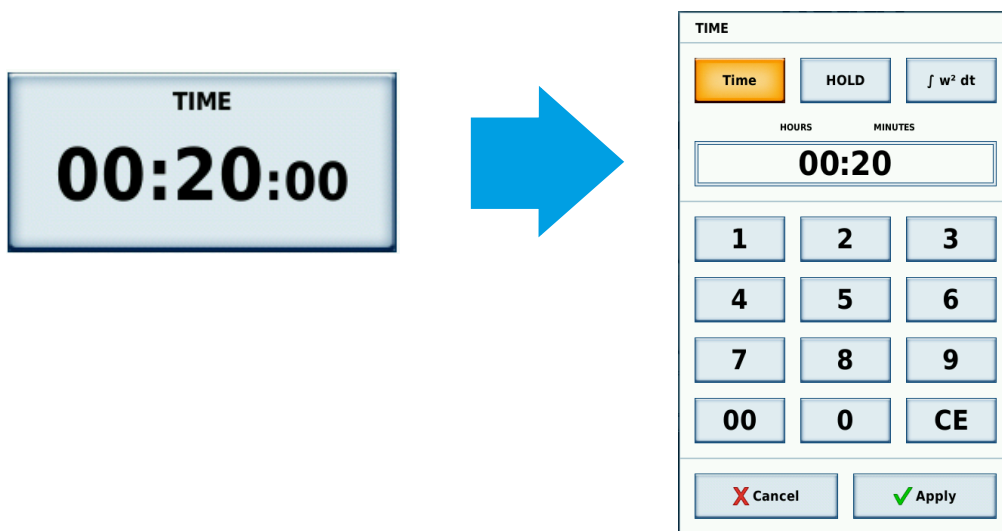

Figure 22: Preset run time

2. Tap **Time**, **HOLD** or $\int w^2 dt$, depending on the value you would like to change.

| Time | Hold | ACE |
|---|---|---|
| Duration of centrifugation run, entered in hh:mm format. | Unlimited duration of centrifugation run. | Accumulated Centrifugal Effect; enter in x.y * 10z: |
| The time you set is counted down while centrifugation is in progress. | The time elapsed so far is displayed while centrifugation is in progress. | x: Integers (1 st input field) |
| Initial value: Your entry in hh:mm: format. | Initial value: 00:00:00 | y: Decimals (2 nd input field) |
| | | z: Power (3 rd input field) |

3. Enter the desired value using the numeric keypad.
The digits appear in the order in which they are entered.
4. Tap **Apply** to confirm your entry.

NOTICE The Accumulated Centrifugal Effect™ (ACE) feature is an integrator function that calculates the effect of speed in relation to time and adjusts run time to account for differences in acceleration. ACE is a mathematical model that helps you to transfer applications and their parameter settings between centrifuges. For example, when you transfer an application to a new centrifuge, ACE ensures that the application runs in exactly the same way and yields the same results as on a legacy centrifuge.

2. 7. 4. Preset Temperature

You can preset the temperature within the following ranges for the different LYNX centrifuge models:

- LYNX 4000: -10° C and +40 °C
- LYNX 6000: -20 °C and +40 °C

NOTICE Entering an out-of-range temperature value produces a TEMPERATURE VALUE INVALID message, showing the limit that would be exceeded.

Preselect the temperature you wish to set as the default value:

1. Tap the **TEMPERATURE** field.
2. The TEMPERATURE setting dialog appears.

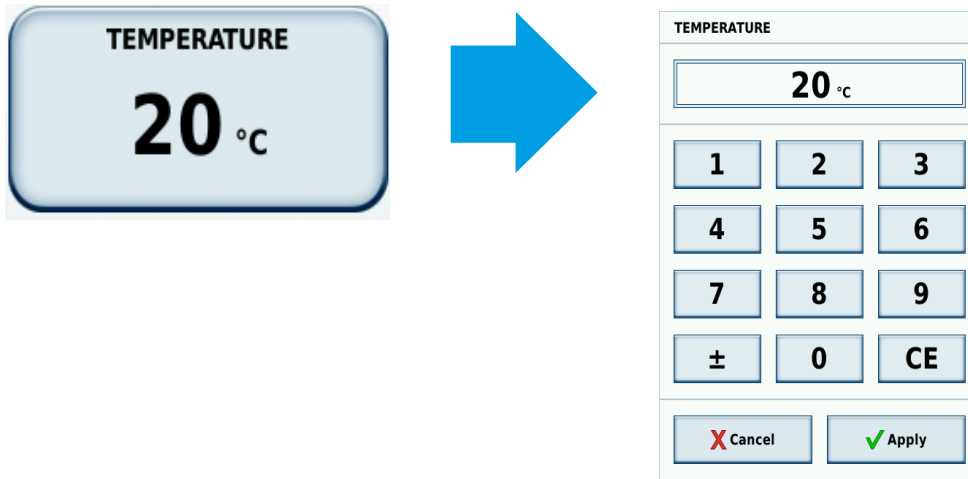

Figure 23: Preset temperature

3. Enter the desired temperature using the numeric keypad.
The digits appear in the order in which they are entered.
4. Tap **Apply** to confirm your entry.

2.7.5. Pre-Warm or Pre-Cool the Centrifuge

To pretemper the centrifuge, proceed as follows:

1. Tap **Configuration**, then **Runs** to select a pre-stored program. [→ ⓘ 34]
2. Select the Program titled **PRETEMPERING**.
The pretempering program is a pre-stored feature of the centrifuge.
3. Tap **Load** to select the program.
4. Go to the main screen to set the required target temperature.
5. Tap the **Start** button to run pretempering.

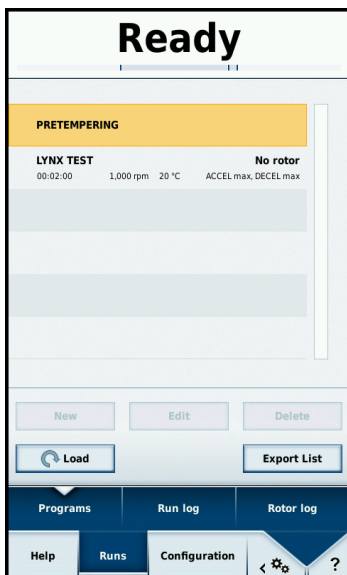

Figure 24: Selecting the PRETEMPERING program

2.8. Centrifugation

WARNING Severe health hazard when centrifuging explosive or flammable materials or substances. Do not centrifuge explosive or flammable materials or substances.

CAUTION Air friction may affect sample integrity. The temperature of the rotor may rise significantly while the centrifuge is spinning. Make sure the centrifuge temperature control capabilities meet your application specification. If necessary make a test run.

Mind the safety zone of minimum 30 cm around the centrifuge. [→ ⓘ 15] Persons and hazardous substances must be kept out of this safety zone while centrifuging. Once the power switch has been turned on, the rotor has been properly installed, the setpoints have been set as explained in the previous section, and the centrifuge door has been closed, you are ready to start.

2. 8. 1. Start Centrifugation

1. Tap the **Start** button on the touchscreen control panel.

The centrifuge accelerates to the preset speed and the timer and status displays on the touchscreen start showing the progress of the centrifugation process.

2. 8. 2. Imbalance Indicator

The centrifuge is fitted with an imbalance detector for maximum operational safety. If a rotor imbalance is detected, an “Imbalance load” error message will be displayed at speeds higher than approx. 300 rpm.

Imbalance at high speeds may indicate a tube breakage or leak or rotor crash. Therefore additional care must be taken, depending on the samples loaded.

The centrifugation run will terminate.

Once the run is stopped, the rotor and load must be checked, ensuring that all buckets are greased and free to swing and that the tubes are balanced. [→ ⓘ 28]

Restart the centrifuge.

For information on troubleshooting: [→ ⓘ 45].

2. 8. 3. Stop Centrifugation

With Preset Run Time

If you have preset a run time and started a centrifugation run, the centrifuge will run at the selected speed until the desired run time has elapsed. It will then automatically decelerate and stop. Once the centrifuge has spun down and stopped, the touchscreen displays a “COMPLETE” message.

Alternatively, you can stop a centrifugation run manually at any time:

1. Tap the **Stop** button on the touchscreen control panel.
2. Wait for the centrifuge to decelerate at the designated rate specified by the program.

When the centrifuge has spun down to a standstill, the message “COMPLETE” appears on the display.

3. Tap the **Open Door** button to open the centrifuge door or press the door unlock button located top right on the centrifuge front side.
4. Remove the centrifuged material.

Continuous Operation

If you have selected continuous operation, you will have to stop the centrifuge manually.

The process is the same as outlined above for operation with a preset run time.

2.9. Programmed Operation

The LYNX 4000 / 6000 centrifuge can store up to 120 user-defined programs.

For instructions on creating and storing programs refer to the separate Thermo Scientific Touchscreen User Interface manual.

2. 9. 1. Start a Centrifuge Program

NOTICE You cannot open the centrifuge door as long as the centrifuge is running.

1. Tap **Configuration**, then **Runs** to select a pre-stored program.
2. Use the scrollbar on the right-hand-side to review the available programs.
The parameters are listed for each pre-stored program.
3. Select the program of your choice.

4. Tap **Load** to select the program with a suitable set of parameters.
5. Tap the **Start** button on the touchscreen.

The centrifuge accelerates to the preset speed with the timer display showing progress.

2.9.2. Stop a Centrifuge Program

If you have started a program and wish to abort before the pre-programmed run time elapses, you must stop the centrifuge manually. The process is the same as outlined above for programs with a preset run time. [→ ⓘ 34]

2.10. Remove the Rotor

To remove the rotor, proceed as follows:

1. Tap the **Open Door** button to open the centrifuge door. [→ ⓘ 24]
2. Grab the rotor handle with one or both hands and press the Auto-Lock button with your thumb.
3. At the same time, pull the rotor straight upwards and remove it from the centrifuge spindle.

NOTICE Do not tilt the rotor while pulling it off the spindle.



Figure 25: Holding the rotor during removal

2.11. Power Down the Centrifuge

Turn off the power switch located on the right-hand side of the centrifuge.

2.12. Aerosol-tight Applications

2.12.1. Basic Principles

Make sure that the sample containers are well suited for the desired centrifugation process.

CAUTION Aerosol-tight rotors and tubes may only be opened in an approved safety workbench when centrifuging dangerous samples. Mind the maximum permissible load.

CAUTION Prior to each use, the seals in the rotor need to be inspected in order to assure that they are correctly seated and are not worn or damaged. Damaged seals are to be replaced immediately. Replacement seals can be re-ordered as a spare part. [→ ⓘ 55] When loading the rotor, ensure that the rotor lid closes securely. Damaged rotor covers are to be replaced immediately.

2.12.2. Fill Level

Do not fill the tubes beyond a safe level to prevent the sample from reaching the top of the tube during centrifugation. For a safe level, fill the tubes only to 2/3 of the rated level.

2.12.3. Aerosol-Tight Rotor Lids

Rotor Lids are for use with fixed angle rotors.

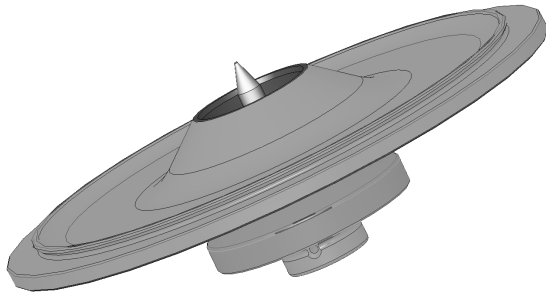

Figure 26: Lid of an aerosol-tight rotor with mandrel

Placing the O-Ring

The O-ring fulfills its purpose best when it is neither stressed nor bulked, that is, when the O-ring is be equally placed in the groove of the lid. Place the O-ring as follows:

1. Place the O-ring above the groove.
2. Push the O-ring on two opposite places into the groove. Make sure the rest of the O-ring is equally distributed.
3. Push the mids of the loose parts into the groove.
4. Push the remaining O-ring into place.

NOTICE If the O-Ring seems to be too long or too short, take it off the lid and repeat the process.

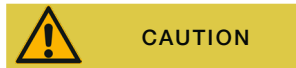

When using an aerosol-tight rotor lid, verify that the sample tubes do not interfere with the rotor lid and compromise its sealing efficiency.

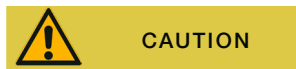

Rotors supplied with a lid for aerosol-tight applications come with a mandrel as an accessory to the Auto-Lock device. Be sure not to place the lid on this mandrel. The lid may be damaged.

Aerosol-tight Closure with ClickSeal

Buckets with ClickSeal closure are for use with swinging bucket rotors

1. If necessary, grease the lid joint before closing the lid. Use grease for bolts and threads (76003500) for this.
2. Raise the latch.

The cap can now be easily placed on the bucket.

3. Lower the latch to close the bucket aerosol-tight; be sure the latch clicks into place.

Make sure that both sides of the latch are closing the bucket cap.

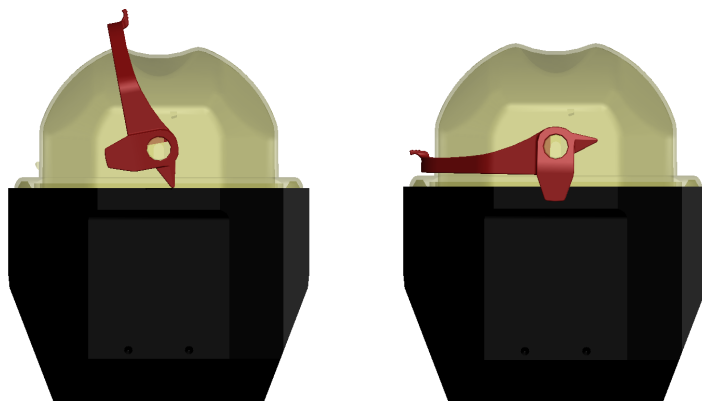



Figure 27: Bucket with open lid (left) and closed lid (right)

| | |
|--|--|
|  CAUTION | If the latch is not flipped down, the caps could be damaged during centrifugation. If the latch has not clicked into place, the bucket is not aerosol-tight. Never lift the bucket at its latch. |
|  CAUTION | Make sure that the length of tubes used allow proper closing of the bucket cap. Otherwise the bucket will not be aerosol-tight. |

2. 12. 4. Checking Aerosol Tightness

The aerosol-tightness testing of the rotors and buckets depends on the microbiological test process in accordance with the EN 61010-2-020 Appendix AA.

Whether or not a rotor is aerosol-tight depends primarily on proper handling.

Make sure that your rotor is aerosol-tight.

The careful inspection of the seals and seal surfaces for signs of wear and damage such as cracks, scratches and embrittlement is extremely important.

Aerosol-tight applications are not possible if the rotor is run without the lid.

Aerosol-tightness requires the correct operation when filling the sample vessels and closing the rotor lid.

Quick Test

As a quick test, it is possible to test the aerosol-tightness using the following process:

1. Lubricate all seals lightly.
Always use the grease for bolts and threads (76003500) when lubricating the seals.
2. Fill the bucket with approx. 10 ml of carbonated water.
3. Close the bucket as explained in the handling instructions.
4. Shake the bucket vigorously using your hands.

This releases the carbonic acid gas that is bound in the water, resulting in excess pressure. Do not apply pressure to the lid when doing so.

Leaks can be detected by escaping water or the sound of escaping gas.

Replace the seals if you detect any leaks. Then repeat the test.

Dry the bucket, bucket cap and the cover seal.

CAUTION Prior to each use, the seals in the rotor are to be inspected in order to assure that they are correctly seated and are not worn or damaged. Damaged seals are to be replaced immediately. Replacement seals can be re-ordered as a spare part. [→  55] When loading the rotor, ensure that the rotor lid closes securely. Damaged rotor covers are to be replaced immediately.

| | |
|--|---|
|  CAUTION | The quick test is not suited for validating the aerosol tightness of a rotor. Check the seals and sealing surfaces of the lid thoroughly. |
|--|---|

2.13. Useful Features

The centrifuge has additional useful features that assist you in handling rotors and accessories.



- ① Rotor lid holder
- ② Rotor landing pad

Figure 28: Additional useful features

2.13.1. Rotor Landing Pad

You can place the rotor on the right hand side of the centrifuge in front of the touchscreen.

CAUTION Do not place anything on the rotor landing pad while the centrifuge door is closed.

2.13.2. Rotor Lid Holder

You can place the rotor lid in the rotor lid holder feature on the left-hand side of the centrifuge.

NOTICE Some rotors lids have a mandrel that is an integral part of the Auto-Lock adapter. Use the rotor lid holder to store the rotor lid.



Figure 29: Using the Auto-Lock rotor lid holder

CAUTION Do not touch the Auto-Lock mandrel inside the rotor lid.

3. Maintenance and Care

3.1. Cleaning Intervals

For the sake of personal, environmental, and material protection, it is your duty to clean and, if necessary, disinfect the centrifuge on a regular basis.

Use only approved cleaning agents. If in doubt, contact Thermo Fisher Scientific.

| Maintenance | Recommended interval |
|-------------------------|----------------------|
| Clean Rotor Chamber | Daily or when soiled |
| Clean Rotor | Daily or when soiled |
| Clean Accessory | Daily or when soiled |
| Clean Housing | Once per month |
| Clean Condenser Filter | Every six months |
| Clean Ventilation Holes | Every six months |

Table 3: Cleaning intervals

3.2. Cleaning Basics

- Use warm water with a neutral detergent that is suitable for use with the materials. If in doubt contact the manufacturer of the cleaning agent.
- Use a soft cloth for cleaning.
- Never use caustic cleaning agents such as soap suds, phosphoric acid, bleaching solutions or scrubbing powder.
- Remove rotor and clean centrifugation chamber with a small amount of cleaning agent on a clean cloth.
- Use a soft brush without metal bristles to remove stubborn residue.
- Afterwards rinse with a small amount of distilled water and remove any remains with absorbent towels.
- Use only cleaning and disinfecting agents with a pH of 6-8.
- After thoroughly cleaning the rotors, they must be inspected for damage, wear and corrosion.
- Make sure that sealing rings are still smooth, not brittle nor otherwise damaged. Some sealing rings are not autoclavable. Replace brittle or damaged sealing rings immediately.

CAUTION Unapproved procedures or agents may deteriorate the materials of the centrifuge and lead to malfunction. Refrain from using any other cleaning or decontamination procedure if you are not entirely sure that the intended procedure is safe for the equipment. Use only cleaning agents that will not damage the equipment. In doubt contact the manufacturer of the cleaning agent. If still in doubt, contact Thermo Fisher Scientific.

3.3. Rotor Care and Inspection Accessories

After thoroughly cleaning the rotors, they must be inspected for damage, wear and corrosion.

The cycle limits of the rotors and buckets are stated on some rotors and buckets and in the technical data section of each rotor. [→  55]

The lifetime of rotors and buckets is dependent on the amount of physical load. Do not exceed the number of cycles stated for rotors and buckets. [→  55]

CAUTION Usage beyond the mechanical load and cycle limits may lead to rotor failure, sample loss and damage to the centrifuge.

CAUTION Do not run any rotor or accessories with signs of damage. Ensure that the rotor, buckets and accessories are within their expected maximum number of cycles. It is recommend that you have rotors and accessories inspected yearly as part of your routine service to ensure safety.

3.3.1. Routine Inspection of Your Rotor

Rotors are frequently damaged in use and this damage may be exacerbated under centrifugal forces. As a result, even a tiny flaw in a critical part of the rotor may generate stresses greater than the rotor was designed to withstand.

Rotors are also subject to high levels of stress due to the centrifugal force created by high rotational speeds, and repeated cycles can cause metal rotors to stretch and change in size. Over time, mechanical stress will cause metal fatigue in a typical fixed angle rotor.

The illustration below shows an example on how to evaluate the operability of a rotor.

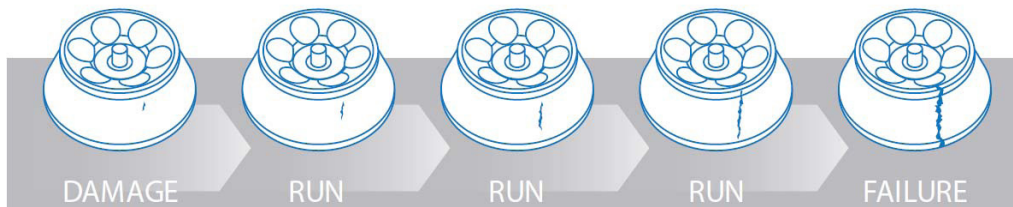

Figure 30: Evaluation of rotor operability

Each time you use a rotor, visually inspect its condition for signs of physical wear or damage:

- Corrosion in the rotor cavities or exterior surfaces. Heavy corrosion can result in premature rotor failure.
- Scratches or gouges to the base metal.
- Missing or worn anodizing.
- Damage to contact points, such as thread, hubs and screws.

3.3.2. Metal Parts

Make sure that the protective coating is complete. It can be removed through wear and chemical attack and can lead to unseen corrosion. In case of corrosion, such as rust or white / metallic pitting, the rotor or accessories must be removed from service immediately. Particular attention must be paid to the bottom of buckets on swinging bucket rotors and tube cavities on fixed angle rotors.

Corrosion, pitting and even minor surface imperfections affect metal rotor life by increasing stress and, as a result, make it difficult to predict at what point the rotor material could fail.

3.3.3. Slide Coated Rotors

Rotor crosses are provided with an anti-friction and corrosion resistant finish.

The following procedure is for rotor crosses and rotor trunnion bolts:

- Regular cleaning of contact area between the rotor and buckets (rotor cross trunnions and bucket grooves) is recommended with a mild detergent (every 300-500 cycles).
- The rotor cross is coated with a special advanced lubricating and protective coating, therefore no grease is necessary.
- Contaminating particles (dirt, dust or debris) in the rotor cross and bucket grooves may lead to imbalance and cleaning will be required.
- The lubricating coating may, over extended periods or under heavy loads, become worn. If this occurs a small amount of greasing of the rotor cross trunnions will be required with bolt grease (75003786).

3.3.4. Plastic Parts

Check for signs of plastic crazing, fading, bruising or cracking. In case of damage the inspected item must be removed from service immediately.

3.3.5. O-Rings

Make sure that O-rings are still smooth, not brittle nor otherwise damaged. Some O-rings are not autoclavable.

Replace brittle or damaged O-rings immediately.

3.3.6. Cycles of Rotors and Buckets

You have to count the cycles of the rotors and buckets using your own method. The centrifuge can not detect the change or replacement of rotors of the same type or of buckets of the same type.

The lifetime of a rotor and buckets depends on the amount of physical load. Do not use rotors and buckets that exceed the maximum number of cycles.

The maximum number of cycles for rotors and buckets is given in the rotor specifications chapter. [→ 55] The maximum number of cycles for buckets is marked on the buckets themselves.

3.4. Cleaning

Clean as follows:

1. Clean rotor, buckets and accessories outside of the centrifugation chamber.
2. Separate rotor, buckets, lids, tubes and sealing rings to allow thorough cleaning. If installed, remove lids from rotors, buckets and tubes. Do not disassemble accessories using tools or force.
3. Rinse rotor and all accessories with warm water and a neutral detergent that is suitable for use with the materials. If in doubt contact the manufacturer of the cleaning agent. Clean away the grease from the rotor trunnions (pivot point for swinging buckets).
4. Use a soft brush without metal bristles to remove stubborn residue.
5. Rinse rotor and all accessories with distilled water.
6. Place the rotor on a plastic grate with their cavities pointing down, to enable the cavities to fully drain and dry. If natural airflow is not sufficient to avoid the gathering of condensation in the cavity or bucket bottom, place the rotor on a ventilated shelf.
7. Dry all of the rotors and accessories after cleaning with a cloth or in a warm air cabinet at a maximum temperature of 50 °C. If drying boxes are used, the temperature must never exceed 50 °C. Higher temperatures could damage the material and shorten the lifetime of the parts.
8. Inspect the rotor and accessories for signs of damage.
9. After cleaning, treat the entire surface of aluminum parts including the cavities with corrosion protection oil (70009824).
10. Treat the bolts of swinging bucket rotors with bolt grease (75003786) if necessary.

CAUTION Before using any cleaning methods, users must check with the manufacturer of the cleaning agents that the proposed method will not damage the equipment.

CAUTION The drive and door lock can be damaged by entering liquids. Do not allow liquids, especially organic solvents, to get on the drive shaft, the drive bearings or the centrifuge door locks. Organic solvents break down the grease in the motor bearing. The drive shaft could lock up.

3.5. Cleaning the Touchscreen

1. Disconnect the power supply cable.
2. Clean the touchscreen using a dry microfiber cloth.
3. If necessary, moisten the microfiber cloth and wipe the touchscreen again.

3.6. Cleaning the Condenser Filter

CAUTION The fins of the condenser have very sharp edges. Be sure to wear protective gloves while removing and reinstalling the filter mat.

The LYNX 4000 / 6000 centrifuge has a single filter mat to prevent dust from entering the centrifuge.

To clean the mat, proceed as follows:

1. Loosen the six screws on the venting grid on the right side of the centrifuge.
2. Remove the venting grid and the filter mat.
3. Use a vacuum cleaner on both sides of the filter mat.
4. Reinstall the filter mat.
5. Reinstall the venting grid.
6. Fasten the venting grid with the six screws.

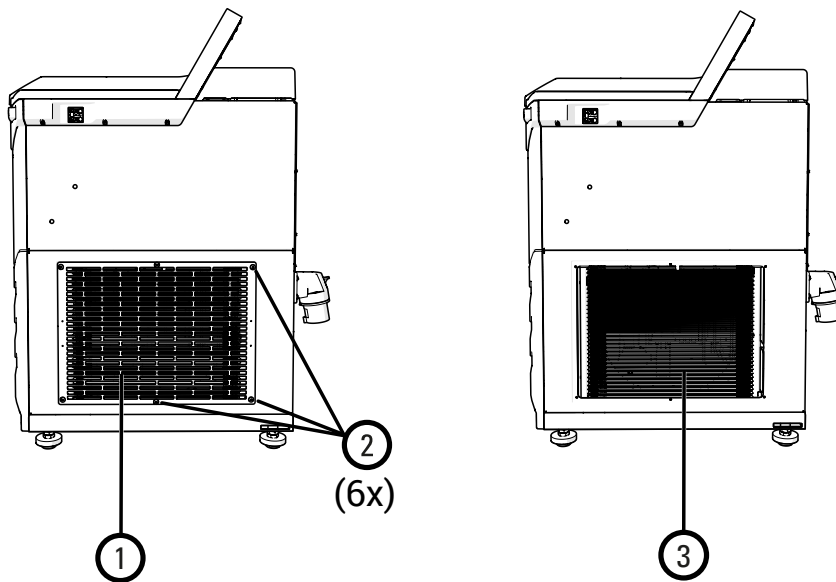

- ① Venting grid
- ② Screws (6 pieces total)
- ③ Filter mat

Figure 31: Venting grid and filter mat

3.7. Disinfection

It is your responsibility to ensure that the level of disinfection is achieved according to your requirements.

WARNING Do not touch contaminated parts. Hazardous infection is possible when touching the contaminated rotor and centrifuge parts. Infectious material can get into the centrifuge when a tube breaks or as a result of spills. In case of contamination, make sure that no one is put at risk. Disinfect the affected parts immediately.

CAUTION Equipment can be damaged by inappropriate disinfection methods or agents. Make sure that the disinfection agent or the method will not damage the equipment. If in doubt contact the manufacturer of the disinfection agent. Observe the safety precautions and handling instructions for the disinfection agents used.

After disinfection:

1. Rinse the centrifuge and all affected accessories with water.
2. Allow to fully drain and dry.
3. After disinfecting, treat the entire surface of aluminum parts including the cavities with corrosion protection oil (70009824).
Treat the bolts of swinging bucket rotors with bolt grease (75003786) if necessary.

3.8. Decontamination

It is your responsibility to ensure that the level of decontamination is achieved according to your requirements.

Given the nature of samples processed in a rotor, biological or radioactive contamination is possible.

For a rotor with biological contamination, a 2 % glutaraldehyde solution, ethylene oxide or ultraviolet radiation are the recommended methods of sterilization.

For a rotor contaminated by a radioactive sample, use a solution of equal parts of 70 % ethanol, 10 % SDS and water.

In addition:

- Do not use chlorine bleach on aluminum rotors.
- When autoclaving, rotor components must be separated.
- If sterilization is not necessary, a 70 % solution of ethanol can be used.
- Most commercially available detergents for radioisotopic contamination are not compatible with aluminum or anodized coatings and shall not be used.
- Rinse with ethanol, followed by water and dry with a soft cloth.
- Do not immerse Thermo Scientific Fiberlite rotors; spin rotor to remove liquid.

- Fiberlite composite rotors are not compatible with ethylene oxide.

WARNING Do not touch contaminated parts. Exposure to radiation is possible when touching the contaminated rotor and centrifuge parts. Contaminated material can get into the centrifuge when a tube breaks or as a result of spills. In case of contamination, make sure that no one is put at risk. Decontaminate the affected parts immediately.

CAUTION Equipment can be damaged by inappropriate decontamination methods or agents. Make sure that the decontamination agent or the method will not damage the equipment. If in doubt contact the manufacturer of the decontamination agent. Observe the safety precautions and handling instructions for the decontamination agents used.

After decontamination:

1. Rinse the centrifuge and all affected accessories with water.
2. Allow to fully drain and dry.
3. After decontaminating, treat the entire surface of aluminum parts including the cavities with corrosion protection oil (70009824).
4. Treat the bolts of swinging bucket rotors with bolt grease (75003786) if necessary.

3.9. Autoclaving

As preparation always separate rotor, buckets, lids, tubes and sealing rings to allow thorough cleaning. If installed, remove lids from rotors, buckets and tubes.

If not stated otherwise on the parts themselves, refer to the information stated for each individual rotor. [→  55]

After autoclaving, treat the entire surface of aluminum parts including the cavities with corrosion protection oil (70009824).

Treat the bolts of swinging bucket rotors with bolt grease (75003786) if necessary.

CAUTION Never exceed the permitted temperature and duration when autoclaving.

NOTICE No chemical additives are permitted in the steam.

Non-autoclavable rotor parts are:

- O-rings for the BIOFlex HC/HS bucket lids (20058488; 20058483)
- Continuous flow system bearings for the TCF-20 rotor (13006)

3.10. Maintenance

3.10.1. Preventive Maintenance

In order to keep this product able to perform in a reliable and safe state it is necessary to replace the vanes of the vacuum pump every 4000 h or 5 years.

3.10.2. Service

The vanes of the vacuum pump are recommended to be replaced by an authorized service technician every 4000 h or 5 years. If the vanes of the vacuum pump are not replaced within this period the performance of the centrifuge can decrease.

Thermo Fisher Scientific recommends having the centrifuge and accessories serviced once a year by an authorized service technician. The service technician checks the following:

- electrical equipment
- suitability of the set-up site
- centrifuge door lock and safety system
- rotor
- integrity of rotor and drive shaft bearings
- protective casing

Before service, centrifuge and rotors must be thoroughly cleaned and decontaminated to ensure full and safe inspection can be completed. Thermo Fisher Scientific offers inspection and service contracts for this work. Any necessary repairs are performed for free during the warranty period and afterwards for a charge. That is only valid if the centrifuge has only been maintained by an authorized Thermo Fisher Scientific service technician.

A validation of the centrifuge is recommended and can be ordered from customer service.

3.11. Lifetime

The centrifuge is specified for a lifetime of 10 years. Decommissioning the centrifuge is suggested when this limit is reached. The lifetime of rotors is based on cycles and specified individually for each rotor. [→ ⓘ 55] Other accessories are not limited by a specific lifetime and need to be replaced when damaged or worn.

3.12. Disposal

For the disposal of the centrifuge mind the regulations in your country. Contact customer service for the disposal of the centrifuge. For contact information check the back page of this manual or visit www.thermofisher.com/centrifuge.

For the countries of the European Union the disposal is regulated by the European Union's Waste Electrical & Electronic Equipment (WEEE) Directive 2012/19/EC.

Mind the information on transport and shipping. [→ ⓘ 16] [→ ⓘ 21]

WARNING When removing the centrifuge and accessories from use for disposal you have to clean and, if necessary, disinfect or decontaminate the entire system. If in doubt contact customer service.

4. Troubleshooting

4.1. Mechanical Emergency Door Release

During a power failure, you will not be able to open the centrifuge door with the regular electric centrifuge door release. A mechanical override is provided to allow sample recovery in the case of an emergency. However, this feature should be used only in emergencies and **after the rotor has come to a complete stop**.

CAUTION The rotor can still be spinning at high speed. If touched, it can cause serious injuries.

Always wait until the rotor has come to a complete stop. The brake does not work during a power failure. The rotor takes much longer than usual to spin down and come to a complete stop.

Proceed as follows:

1. **Wait until the rotor has stopped.** This may take some 60 minutes or even longer.
2. Inspect the view port for visual confirmation that the rotor come to a complete standstill.
3. Locate the two white plastic plugs on the left side panel of the centrifuge housing.
4. Using a small flat screwdriver, carefully pry these plugs from the side panel.
Once the plug is removed, it will expose the release cords.
5. Pull both release cords at the same time to trigger the mechanical centrifuge door release.

The centrifuge door opens, and the samples can be removed.

CAUTION Never use your hand or any tools to brake the rotor.

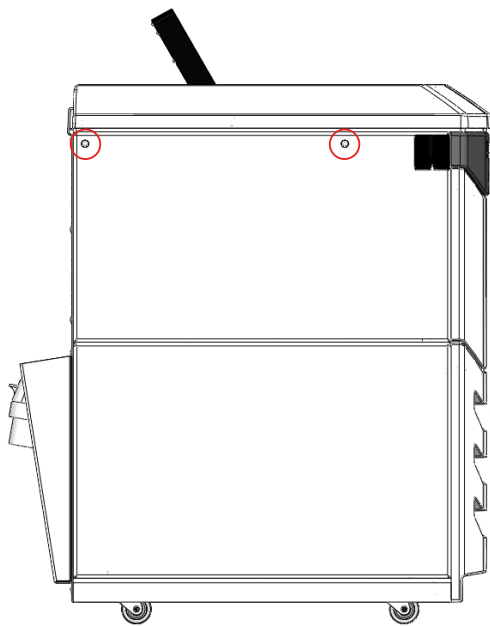



Figure 32: Emergency door release

6. Insert the release cords back into the centrifuge and reinstall the plugs.
7. Reconnect the centrifuge when power has been restored.
8. Switch on the centrifuge.
Restoring power to the centrifuge will reset the locks.
9. Tap the **Start** button on the touchscreen or press the door unlock button located top right on the centrifuge front side. [→  26]

4.2. Ice Formation

Warm humid air in combination with a cold centrifugation chamber can lead to formation of ice. To remove the ice from the centrifugation chamber, proceed as follows:

1. Open the centrifuge door.
2. Remove the rotor. [→  35]
3. Let the ice melt.

NOTICE Do not use any sharp tools, aggressive liquids or fire to accelerate the melting process. If necessary use warm water to speed up melting.

4. Remove the water from the centrifugation chamber.
5. Clean the centrifugation chamber. [→  41]

4.3. Troubleshooting Guide

When the centrifuge detects an error condition, the touchscreen turns red and an error message appears on top of the standard display content.



Figure 33: Error message example

4.3.1. Troubleshooting Centrifuge Issues

NOTICE If an error message shows up that is not listed in this table, a service technician must be contacted.

| Error | Description | Solutions |
|-------------------------|---|--|
| E-1 through E-97 | Read manual | Restart the centrifuge. If the message appears again, inform a service technician. |
| E-98 | The centrifuge cannot be operated. The run does not start or the centrifuge brakes and ends the run. | Imbalance detected. Check the load placed in the rotor. Check that the bolts of the rotor are well greased. Restart the centrifuge. If the message appears again, inform a service technician. |
| E-99 | | Restart the centrifuge. If the message appears again, inform a service technician. |

| Error | Description | Solutions |
|-------------|---|---|
| E-86 | At very high speeds the LYNX 6000 centrifuge creates a partial vacuum. In case of problems due to the vacuum pump or a seal failure the LYNX 6000 centrifuge displays an error message. | Contact a service technician. Until the problem has been solved you can operate the LYNX 6000 centrifuge at lower speeds. Confirm with the speeds given for the LYNX 4000 centrifuge in the rotor specifications chapter. |

Table 4: Troubleshooting centrifuge error messages

4.3.2. Troubleshooting Rotor Issues

CAUTION Ensure the safety of your lab staff by implementing preventive measures or taking recommended action. If in doubt about the operability of a rotor, call customer service for an inspection.

NOTICE Protect your rotor against damage or failure with preventive measures and maintain maximum centrifuge performance.

The following table lists cases of visual rotor damage and recommends preventive measures as well as troubleshooting actions.

| Potential Damage | Preventive Measures | Recommended Action |
|---|---|--|
| Damage to lid assembly | <ul style="list-style-type: none"> ▪ Lubricate periodically with the grease supplied. ▪ Keep lid assembly lubricated with the grease supplied. ▪ Avoid banging or dropping. ▪ Use care when removing O-rings. ▪ Clean with non-abrasive cloth and mild detergent. | Contact a service technician. |
| Damage to biocontainment sealing lid | <ul style="list-style-type: none"> ▪ Use care when removing O-rings. ▪ Inspect and replace O-rings regularly. | Replace sealing lid to ensure proper containment. |
| Scoring to the bottom of the rotor (outside of cone area) | <ul style="list-style-type: none"> ▪ Gently place rotor on the centrifuge spindle. ▪ Clean with non-abrasive cloth and mild detergent. ▪ Inspect centrifuge mated parts for burrs and ensure no debris in centrifuge chamber. ▪ Store rotor on rotor stand or soft surface. | Contact a service technician. Return rotor to manufacturer for evaluation or replacement. |
| Damage to the rotor drive pins | <ul style="list-style-type: none"> ▪ Gently place rotor on the centrifuge spindle. ▪ Ensure rotor is securely locked to centrifuge drive. | Contact a service technician. Return rotor to manufacturer for replacement of rotor hub adapter or replace rotor depending on degree of damage/corrosion. |
| Pitting from corrosion in the bottom of tube cavity (metal rotors) | <ul style="list-style-type: none"> ▪ Ensure rotor is dried thoroughly between runs. ▪ Clean rotor immediately after use and when exposed to chemicals with approved solvent. ▪ Remove adapters after use, rinse and dry. | Contact a service technician. Return rotor to manufacturer for evaluation. |
| Cracked or delaminated rotor | <ul style="list-style-type: none"> ▪ Avoid sharp impact. ▪ Avoid harsh chemicals. ▪ Clean the surface of rotor and coat with a thin layer of oil to prevent corrosion. | Contact a service technician. Return rotor to manufacturer for evaluation. |
| Damage to bucket seats | <ul style="list-style-type: none"> ▪ Lubricate buckets regularly. ▪ Slide buckets into place carefully to avoid dropping or forcing into position. | Replace rotor bucket set. |

| Potential Damage | Preventive Measures | Recommended Action |
|--|---|---|
| Rotor bucket cap damage | <ul style="list-style-type: none"> ▪ Avoid cross threading of parts. ▪ Never use metallic objects to clean. ▪ Clean and lubricate regularly. | Replace rotor bucket caps and return set for rebalancing (if applicable). |
| Rotor bucket damage | <ul style="list-style-type: none"> ▪ Avoid banging or dropping. ▪ Do not exceed rotor's maximum compartment mass. ▪ Ensure buckets are free of debris. | Replace rotor buckets or return bucket set for rebalancing. |
| Gouges or corrosion on surface of rotor | <ul style="list-style-type: none"> ▪ Inspect before every use. | <p>Contact a service technician.</p> <p>Return rotor to manufacturer for evaluation or replacement.</p> |
| Light scratches on surface | <ul style="list-style-type: none"> ▪ Avoid banging or dropping. ▪ Never use metallic objects to remove debris. | Monitor to ensure no corrosion has occurred. |
| Bent centrifuge spindle | <ul style="list-style-type: none"> ▪ Remove rotor in a straight up motion. ▪ Ensure samples are properly balanced. | Contact a service technician for replacement of centrifuge spindle. |

Table 5: Rotor inspection instructions

4.4. Information for the Customer Service

If you need to contact customer service, please provide the order no. and the serial number of your centrifuge. This information can be found on the nameplate at the back near the power inlet socket.

In addition the customer service also needs the Software ID. **This information is available from the system menu.**

If you need to contact a service technician, please provide the order number and the serial number of your centrifuge. This information can be found on the back near the inlet for the power supply cable.

To identify the software version, proceed as follows:

1. Switch on the centrifuge.
2. Open the **Configuration** menu. [→  24]
3. Select **Configuration**.
4. Select **Device**.
5. Read the required data and take notes.
6. Communicate the software version to the service technician.

5. Technical Specifications

5.1. Product Features

The centrifuges are compatible with multiple rotors and a wide range of tubes. [→ ⓘ 55]

The set speed is reached within seconds. The maintenance-free induction motor ensures quiet and low-vibration operation even at high speeds, and guarantees a very long lifetime.

The user-friendly control panel makes it easy to preset the speed, RCF value, run time, temperature, and run profile (acceleration and deceleration curves). You can choose to have speed displayed in RPM or RCF mode.

These settings can be changed even while the centrifuge is running.

The centrifuges has the following features:

- The housing and rotor chamber consist of stainless steel plate, the interior of armored steel, while the front panel is made of high-impact resistant plastics.
- The centrifuge door is equipped with a centrifuge door lock.
- The centrifuge door can only be opened while the centrifuge is switched on and the rotor has come to a complete stop. The centrifuge cannot be started until the centrifuge door has been closed properly.
- The drive is an induction motor without carbon brushes.
- The rotor recognition Auto-ID identifies the rotor when inserted thus avoiding over-speeding the rotor and simplifying run set-up.
- An electronic imbalance recognition is designed to prevent damage to the centrifuge spindle.
- Centrifuge door emergency release: For emergencies only, e.g. to retrieve samples during power failures. [→ ⓘ 45]
- The LYNX 6000 centrifuge can be equipped with an optional HEPA filter (HEPA-Filter Kit 75000011).
- The LYNX 4000 / 6000 centrifuge can be bolted down to the floor (Optional Seismic Bolt-down Kit 75006500) optionally. [→ ⓘ 15]

5.2. Product Features and Materials Used

| Component / Function | Description / Features |
|--------------------------------------|--|
| Structure / Housing | Galvanized steel chassis with armored plating |
| Rotor Chamber | Stainless steel |
| Drive | Induction drive without carbon brushes |
| Touchscreen and Display | Easy-to-clean touchscreen and display surface |
| Controls | Microprocessor-controlled |
| Internal Memory | Most recent data is saved |
| Functions | RCF, temperature, and pre-temp selection |
| Acceleration / Deceleration Profiles | 9 acceleration and 10 deceleration curves |
| Rotor Recognition | Automatically and instantly, upon insertion of rotor |
| Imbalance Recognition | Electronic, contingent on rotor and speed |
| Centrifuge Door Lock | Automatic centrifuge door closing and locking starting from an initial hold position |
| Rotor Lid Holder | Left-hand side of the centrifuge |
| Rotor Landing Pad | Right-hand side of centrifuge next to touchscreen |

Table 6: Product features and materials used

5.3. List of Centrifuges

| Cat. No. | Description |
|----------|---|
| 75008580 | LYNX 4000 Superspeed Centrifuge, 200-240 V \pm 10 % |
| 75008581 | LYNX 4000 Superspeed Centrifuge, 220(380)-240(415) V \pm 10 % |
| 75008590 | LYNX 6000 Superspeed Centrifuge, 200-208 / 220-240 V \pm 10 % |
| 75008591 | LYNX 6000 Superspeed Centrifuge, 220(380)-240(415) V \pm 10 % |
| 75008592 | LYNX 6000 Superspeed Centrifuge, 220-240 V \pm 10% |

Table 7: List of centrifuges

5.4. List of Rotors

| Cat. No. | Description |
|------------|------------------------|
| 75003000 | BIOFlex HC |
| 75003002 | BIOFlex HS |
| 75003010 | TH13-6x50 |
| 096-061075 | F9-6x1000 LEX |
| 096-041075 | F10-4x1000 LEX |
| 096-062375 | F12-6x500 LEX |
| 096-062075 | F14-6x250y |
| 096-145075 | F14-14x50cy |
| 096-124375 | F20-12x50 LEX |
| 096-084275 | F21-8x50y |
| 096-484075 | F23-48x1.5 |
| 75003013 | TCF-20 Zonal |
| 75003012 | TCF-20 Continuous Flow |
| 75003009 | T29-8x50 |
| 75003008 | A27-8x50 |
| 75003007 | A27-6x50 |
| 75003005 | A22-24x16 |
| 75003004 | A21-24x15c |
| 75003006 | A23-6x100 |

Table 8: List of rotors

For more information visit our website at www.thermofisher.com/rotors

5.5. Technical Specifications

Thermo Scientific LYNX 4000



| | |
|---|---------------------------------|
| Running Time | 99 h, 59 min, 59 sec, hold |
| Maximum Speed n_{max} | 24 000 rpm (depending on rotor) |
| Minimum Speed n_{min} | 500 rpm |
| Maximum RCF-Value at n_{max} | 68 905 x g |
| Maximum Kinetic Energy | < 203 kJ |
| Noise Level for Swinging Bucket Rotors at Maximum Speed | < 61 dB (A) ^{***} |
| Noise Level for Fixed Angle Rotors at Maximum Speed | < 58 dB (A) ^{***} |
| Temperature Setting Range | -10 °C to +40 °C |

Environmental Conditions

| | |
|--|---|
| Storage and Shipping | Temperature: -10 °C to 55 °C Humidity: 15 % to 85 % |
| Operation | Use in interior spaces Altitudes of up to 3 000 m above Sea Level Max. relative humidity 85 % up to 31 °C Permissible Ambient Temperature: +2 °C to +35 °C |
| Pollution Degree | 2 |
| Overvoltage Category | II |
| Heat Dissipation | |
| - Swinging Bucket Rotors* | 2.5 kWh |
| - Fixed Angle Rotors** | 2.25 kWh |
| IP (degree of protection to IEC 60529) | 20 |

Dimensions

| | |
|-------------------------------------|----------|
| Height with Door Closed (incl. GUI) | 1 045 mm |
| Height with Door Open | 1 530 mm |
| Width | 735 mm |
| Depth | 810 mm |

| | |
|-----------------------------|--------|
| Weight without Rotor | 256 kg |
|-----------------------------|--------|

* Typical application: BIOFlex HC Rotor, 4 °C, 5500 rpm, 4 runs per hour.
 ** Typical application: A-27-8x50 Rotor, 4 °C, 24000 rpm, 4 runs per hour.
 *** as measured at 1 m distance and at 1.6 m height (Swinging Bucket Rotor BIOFlex HC, 4 x 1000 mL, 5500 rpm; Fixed Angle Rotor T29, 8 x 50 mL, 24000 rpm)

Table 9: Technical specifications LYNX 4000

Thermo Scientific LYNX 6000



| | |
|---|--------------------------------|
| Running Time | 99 h, 59 min, 59 sec, hold |
| Maximum Speed n_{\max} | 29000 rpm (depending on rotor) |
| Minimum Speed n_{\min} | 500 rpm |
| Maximum RCF-Value at n_{\max} | 100000 x g |
| Maximum Kinetic Energy | < 203 kJ |
| Noise Level for Swinging Bucket Rotors at Maximum Speed | < 61 dB (A)*** |
| Noise Level for Fixed Angle Rotors at Maximum Speed | < 57 dB (A)*** |
| Temperature Setting Range | -20 °C to +40 °C |

Environmental Conditions

| | |
|--|--|
| Storage and Shipping | Temperature: -10 °C to 55 °C Humidity: 15 % to 85 % |
| Operation | Use in interior spaces Altitudes of up to 3000 m above Sea Level Max. relative humidity 85 % up to 31 °C Permissible Ambient Temperature: +2 °C to +35 °C |
| Pollution Degree | 2 |
| Overvoltage Category | II |
| Heat Dissipation | |
| - Swinging Bucket Rotors* | 2.5 kWh |
| - Fixed Angle Rotors** | 1.5 kWh |
| IP (degree of protection to IEC 60529) | 20 |

Dimensions

| | |
|-------------------------------------|---------|
| Height with Door Closed (incl. GUI) | 1045 mm |
| Height with Door Open | 1530 mm |
| Width | 735 mm |
| Depth | 810 mm |

Weight without Rotor 266 kg

* Typical application: BIOFlex HC Rotor, 4 °C, 5500 rpm, 4 runs per hour.

** Typical application: A-27-8x50 Rotor, 4 °C, 24000 rpm, 4 runs per hour.

*** as measured at 1 m distance and at 1.6 m height (Swinging Bucket Rotor BIOFlex HC, 4 x 1000 mL, 5500 rpm; Fixed Angle Rotor T29, 8 x 50 mL, 29000 rpm)

Table 10: Technical specifications LYNX 6000

5.6. Directives, Standards and Guidelines

| Tension / Frequency | Directives and Guidelines | Standards |
|---|--|--|
| Europe 220-240 V, 50 / 60 Hz 380-415 V, 50 / 60 Hz | <u>2006/42/EC</u> Machinery Directive <u>2014/35/EU</u> Low Voltage (Protective Goals) <u>2014/30/EC</u> Electromagnetic Compatibility (EMC) <u>2011/65/EC RoHS</u> and all applicable amendments and additions Directive on the Restriction of the use of certain Hazardous Substances in electrical and electronic equipment. | EN 61010-1 EN 61010-2-020 EN 61010-2-011 EN 61326-1 Class B EN ISO 14971 ISO 9001 |
| USA & Canada 208 V, 60 Hz 240 V, 60 Hz | | ANSI/UL 61010-1 UL 61010-2-020 UL 61010-2-011 FCC Part 15 ICES-001 EN ISO 14971 ISO 9001 |
| Japan 200 V, 50 / 60 Hz | | IEC 61010-1 IEC 61010-2-020 IEC 61010-2-011 IEC 61326-1 Class B |
| China 220-240 V, 50 / 60 Hz 380-415 V, 50 / 60 Hz | | EN ISO 14971 ISO 9001 |

Table 11: Directives, standards and guidelines

NOTICE This equipment has been tested and found to comply with the limits for a Class B digital device, pursuant to part 15 of the FCC Rules. These limits are designed to provide reasonable protection against harmful interference in a residential installation. This equipment generates, uses and can radiate radio frequency energy and, if not installed and used in accordance with the instructions, may cause harmful interference to radio communications. However, there is no guarantee that interference will not occur in a particular installation. If this equipment does cause harmful interference to radio or television reception, which can be determined by turning the equipment off and on, the user is encouraged to try to correct the interference by one or more of the following measures:

- Reorient or relocate the receiving antenna.
- Increase the separation between the equipment and receiver.
- Connect the equipment into an outlet on a circuit different from that to which the receiver is connected.
- Consult the dealer or an experienced radio/TV technician for help.

5.7. Mains Supply

| Mains Voltage [V] | Frequency [Hz] | Rated Current [A] | Power Consumption [W] | Building Fuse [A] | Equipment Fuse [A] |
|--------------------------------|----------------|-------------------|-----------------------|--------------------|--------------------|
| 200-240 | 50/60 | 22 | 4200 | 30 ¹⁾²⁾ | 30 |
| 200-208 / 220-240 | 50/60 | 22 | 4200 | 30 ¹⁾²⁾ | 30 |
| 220-240 | 50/60 | 22 | 4200 | 22 | 30 |
| 220(380)-240(415) (3-phase) | 50/60 | 14.5 | 4200 | 16 ³⁾ | 16 |

1) Use a 32 A Trip Char. B or C circuit breaker (D or K are also applicable).

2) For North America: use for example GES-9888 30 A.

3) For 3-phase (unbalanced load, no L3) use a 32 A Trip Char. B or C circuit breaker (D or K are also applicable).

Table 12: Mains supply

5.8. Refrigerants

| Cat. No. | Centrifuge | Refrigerant | Quantity | Low Side Max. Pressure | High Side Max. Pressure | GWP | CO2e |
|----------|------------|-------------|----------|------------------------|-------------------------|-----|--------|
| 75008580 | LYNX 4000 | R-744 | 1.2 kg | 95 bar | 140 bar | 1 | 1.2 kg |
| 75008581 | LYNX 4000 | R-744 | 1.2 kg | 95 bar | 140 bar | 1 | 1.2 kg |
| 75008590 | LYNX 6000 | R-744 | 1.2 kg | 95 bar | 140 bar | 1 | 1.2 kg |
| 75008591 | LYNX 6000 | R-744 | 1.2 kg | 95 bar | 140 bar | 1 | 1.2 kg |
| 75008592 | LYNX 6000 | R-744 | 1.2 kg | 95 bar | 140 bar | 1 | 1.2 kg |

Table 13: Refrigerants

6. Rotor Specifications

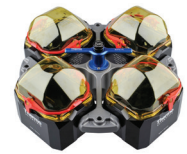

6.1. BIOFlex HC

6.1.1. Items Supplied

| Item | Cat. No. | Quantity |
|--|----------|----------|
| BIOFlex HC Rotor, including 4 Buckets | 75003000 | 1 |
| 1000 mL Polypropylene Wide-Mouth Bio-Bottles | 75007300 | 4 |
| 1000 mL Adapters | 75007301 | 4 |
| Bolt Grease | 75003786 | 1 |
| Anti-corrosion Oil | 70009824 | 1 |

Table 14: Items supplied BIOFlex HC rotor

6.1.2. Technical Data

| | |
|-------------------------------|--|
| Type | Swinging Bucket |
| Material | Stainless Steel with Aluminum Buckets |
| Tube Dimensions Ø x L | 126 x 140 mm |
| Net Weight | 5.35 kg/11.8 lbs (Rotor Body) 10.2 kg/22.5 lbs (Cross with Buckets) |
| Capacity | 4 x 1000 mL |
| Maximum Permissible Load | 4 x 1500 g |
| Maximum Number of Cycles | 14 000 |
| Radius (max. / min.) | 209 mm / 108 mm |
| Angle | 90° |
| Max. Autoclaving Temperature* | 121 °C |
| Aerosol-tight | Yes |

* Not autoclavable: O-Ring ClickSeal Lid (20058488).

Table 15: BIOFlex HC rotor technical data

6.1.3. Rotor Performance Data

| Centrifuge | LYNX 4000 | LYNX 6000 |
|--|--------------|--------------|
| Maximum Speed | 5500 rpm | 5500 rpm |
| Maximum RCF-Value | 7 068 x g | 7 068 x g |
| K-Factor at n_{max} | 5522 | 5522 |
| Acceleration / Braking Time | 80 s / 105 s | 80 s / 110 s |
| Maximum Speed at 4 °C | 5500 rpm | 5500 rpm |
| Min. Sample Temperature at Max. Speed (Ambient Temperature 23 °C, Run Time 60 minutes) | -10 °C | -10 °C |

Table 16: BIOFlex HC rotor performance data

6.1.4. Accessories

| Description | Cat. No. | Max. speed (rpm) | Max. RCF (x g) |
|---|----------|------------------|----------------|
| Thermo Scientific ClickSeal Biocontainment Lids (qty. 4) | 75007309 | - | - |
| O-Ring replacment kit for ClickSeal lids (qty. 4) | 75007001 | - | - |
| Rotor stand | 75003711 | - | - |
| Replacement BIOFlex HC buckets, set of 4 | 75003021 | - | - |
| Replacement biocontainment cap for double biocontainment vessel for 50 mL conical tube (qty. 1) | 50129119 | - | - |
| Replacement O-Rings for 50 mL bucket (set of 12) | 75003789 | - | - |
| Replacement microplate carrier pad | 20056846 | - | - |

Table 17: BIOFlex HC rotor accessories

6.1.5. Labware

| Tube vol. (mL) | Vol. fill (mL) | Description | Cat. No. | Qty./pkg. | Tubes/rotor | Max. speed (rpm) | Max. RCF ² (x g) | Dims ØxL (mm) | Required tube closures, adapters, tools & accessories | | | |
|----------------|----------------|-------------------------------------|-----------|-----------|-------------|------------------|-----------------------------|---------------|---|-------------|---------------------|---------------------|
| | | | | | | | | | Type | Cat. No. | Qty./pkg. | Description |
| 1000.0 | 1000.0 | Polypropylene Wide-Mouth Bio-Bottle | 75007300 | 4 | 4 | 5500 | 7068 | 126 x 140 | Adapter | 75007301 | 4 | 1 place/adapter |
| 750.0 | 750.0 | Polypropylene Wide-Mouth Bio-Bottle | 75006443 | 1 | 4 | 3600 | 3028 | 98 x 133 | Adapter | 75007304 | 4 | 1 place/adapter |
| 500.0 | 500.0 | Fiberlite PPCO Bottle | 010-1493 | 6 | 4 | 5500 | 7068 | 70 x 160 | Closure | Included | 6 | PPGF Cap w/ PP Plug |
| 500.0 | 500.0 | Fiberlite PC Bottle | 010-1494 | 6 | 4 | 5500 | 7068 | 70 x 160 | Closure | Included | 36 | PPGF Cap w/ PP Plug |
| 500.0 | 450.0 | Nalgene PP Bottle | 3141-0500 | 24 | 4 | 5500 | 7068 | 70 x 160 | Adapter | 75004253 | 4 | 1 place/adapter |
| 500.0 | 450.0 | Nalgene PC Bottle | 3140-0500 | 24 | 4 | 5500 | 7068 | 70 x 160 | Adapter | 75004253 | 4 | 1 place/adapter |
| 500.0 | 450.0 | Corning™ Conical Bottle | - | - | 4 | 5500 | 7068 | 98 x 133 | Adapter | 75007302 | 4 | 1 place/adapter |
| 250.0 | 250.0 | Fiberlite PPCO Bottle | 010-1495 | 6 | 8 | 5500 | 7068 | 61 x 124 | Closure | Included | 6 | PPGF Cap w/ PP Plug |
| 250.0 | 250.0 | Fiberlite PC Bottle | 010-1496 | 6 | 8 | 5500 | 7068 | 61 x 124 | Closure | Included | 6 | PPGF Cap w/ PP Plug |
| 250.0 | 250.0 | Nalgene PP Bottle | 3141-0250 | 36 | 8 | 5500 | 7068 | 62 x 130 | Adapter | 75007305 | 4 | 2 places/adapter |
| 250.0 | 250.0 | Nalgene PC Bottle | 3140-0250 | 36 | 8 | 5500 | 7068 | 62 x 130 | Adapter | 75007305 | 4 | 2 places/adapter |
| 250.0 | 250.0 | Nalgene Wide-Mouth Conical Bottle | - | - | 4 | 5500 | 7068 | 26 x 145 | Adapter | 75005392 | 4 | 1 place/adapter |
| 250.0 | - | Corning™ Conical Bottle | - | - | 4 | 5500 | 7068 | 26 x 145 | Adapter | 75005392 | 4 | 1 place/adapter |
| 225.0 | - | Falcon™ Conical Bottle | - | - | 8 | 5500 | 7068 | 62 x 130 | Adapter | 75007305 | 4 | 2 places/adapter |
| | | | | | | | | | Adapter | BD 352090 | Purchase separately | 1 place/adapter |
| 200.0 | - | Nunc Conical Bottle | 376813 | 48 | 8 | 5500 | 7068 | 26.5 x 139 | Adapter | 75007305 | 4 | 2 places/adapter |
| | | | | | | | | | Adapter | Nunc 377585 | - | 1 place/adapter |

| Tube vol. (mL) | Vol. fill (mL) | Description | Cat. No. | Qty./pkg. | Tubes/rotor | Max. speed (rpm) | Max. RCF ² (x g) | Dims ØxL (mm) | Required tube closures, adapters, tools & accessories | | | |
|----------------|----------------|--|-----------|-----------|-------------|------------------|-----------------------------|---------------|---|---------------------|-----------|------------------------------|
| | | | | | | | | | Type | Cat. No. | Qty./pkg. | Description |
| 175.0 | 175.0 | Nalgene PP Wide-Mouth Conical Bottle | 3143-0175 | 36 | 8 | 5500 | 7068 | 62 x 130 | Adapter | 75007305 | 4 | 2 places/adapter |
| | | | | | | | | | Adapter | Nalgene DS3126-0175 | 2 | 1 place/adapter |
| 175.0 | 175.0 | Nalgene PP Wide-Mouth Conical Bottle | 3144-0175 | 36 | 8 | 5500 | 7068 | 62 x 130 | Adapter | 75007305 | 4 | 2 places/adapter |
| | | | | | | | | | Adapter | Nalgene DS3126-0175 | 2 | 1 place/adapter |
| 100.0 | - | Round Bottom Open-Top Tube | - | - | 30 | 4500 | 4732 | 45 x 123 | Adapter | 75101073 | 4 | 2 places/adapter |
| | | | | | | | | | BIOLink Adapter | 75007304 | 4 | - |
| 50.0 | - | Conical Tissue Culture Tube | - | - | 40 | 5500 | 7068 | 29.5 x 116 | Adapter | 75003674 | 4 | 10 places/adapter |
| 50.0 | - | Double Biocontainment Vessels for 50 mL Conical Tube | - | - | 20 | 5500 | 7068 | 29.5 x 116 | Adapter | 75004255 | 2 | 5 places/adapte |
| | | | | | | | | | Vessel | 75003787 | 1 | (10 included per 2 adapters) |
| | | Nalgene Oak Ridge Tube | - | - | 20 | 5500 | 7068 | 1 x 30 | Adapter | 75005802 | 2 | 1 place/adapter |
| | | Nalgene Oak Ridge Tube | - | - | 20 | 5500 | 7068 | 1 x 16 | Adapter | 75005803 | 2 | 1 place/adapter |
| | | Conical Tissue Culture Tube | - | - | 20 | 5500 | 7068 | 1 x 15 | Adapter | 75005808 | 2 | 1 place/adapter |
| | | Nalgene Oak Ridge Tube | - | - | 20 | 5500 | 7068 | 1 x 16 | Adapter | 75005803 | 2 | 1 place/adapter |
| | | Blood Collection Tube | - | - | 20 | 5500 | 7068 | 1 x 10 | Adapter | 75005804 | 2 | 1 place/adapter |
| | | Blood Collection Tube | - | - | 20 | 5500 | 7068 | 1 x 7 | Adapter | 75005805 | 2 | 1 place/adapter |
| | | Blood Collection Tube (11) | - | - | 40 | 5500 | 7068 | 2 x 3.5 | Adapter | 75005806 | 2 | 1 place/adapter |
| | | Microtube | - | - | 40 | 5500 | 7068 | 2 x 1.5/2 | Adapter | 75005807 | 2 | 1 place/adapter |
| 50.0 | 42.0 | Nalgene PP Oak Ridge Tube | 3139-0050 | 100 | 48 | 5500 | 7068 | 29.5 x 120 | Adapter | 75004252 | 4 | 1 place/adapter |
| 50.0 | 42.0 | Nalgene PP Oak Ridge Tube | 3138-0050 | 100 | 48 | 5500 | 7068 | 29.5 x 120 | Adapter | 75004252 | 4 | 12 places/adapter |
| 50.0 | 50.0 | Conical or Skirted Tube | - | - | 20 | 5500 | 7068 | 29.5 x 120 | Adapter | 75003824 | 4 | 12 places/adapter |
| | | | | | | | | | BIOLink Adapter | 75007304 | 4 | - |
| 25.0 | 25.0 | Universal Conical or Skirted Tube | - | - | 28 | 4500 | 4732 | 29.5 x 120 | Adapter | 75003716 | 4 | 7 places/adapter |
| | | | | | | | | | BIOLink Adapter | 75007304 | 4 | - |
| 25.0 | 25.0 | Universal Conical or Skirted Tube | - | - | 28 | 4500 | 4732 | 29.5 x 120 | Adapter | 75003716 | 4 | 7 places/adapter |
| | | | | | | | | | BIOLink Adapter | 75007304 | 4 | - |
| 16.0 | 16.0 | Nalgene PP Round Bottom Tube | 3139-0016 | 50 | 48 | 4500 | 4732 | 18 x 134 | Adapter | 75003718 | 4 | 12 places/adapter |

| Tube vol. (mL) | Vol. fill (mL) | Description | Cat. No. | Qty./pkg. | Tubes/rotor | Max. speed (rpm) | Max. RCF ² (x g) | Dims ØxL (mm) | Required tube closures, adapters, tools & accessories | | | |
|----------------|----------------|--|-----------|-----------|-------------|------------------|-----------------------------|---------------|---|----------|-----------|-------------------|
| | | | | | | | | | Type | Cat. No. | Qty./pkg. | Description |
| | | | | | | | | | BIOLink Adapter | 75007304 | 4 | - |
| 16.0 | 16.0 | Nalgene PC Round Bottom Tube | 3138-0016 | 50 | 48 | 4500 | 4732 | 18 x 134 | Adapter | 75003718 | 4 | 12 places/adapter |
| | | | | | | | | | BIOLink Adapter | 75007304 | 4 | - |
| 15.0 | - | Conical Tissue Culture Tube | - | - | 96 | 5500 | 7068 | 17.5 x 121 | Adapter | 75007306 | 4 | 24 places/adapter |
| 15.0 | - | Blood Collection Tube | - | - | 32 | 4500 | 4732 | 17 x 125 | Adapter | 75003719 | 4 | 8 places/adapter |
| | | | | | | | | | BIOLink Adapter | 75007304 | 4 | - |
| 10 | - | Blood Collection Tube or Corex™/Kimble™ Tube | - | - | 148 | 4500 | 4732 | 17 x 110 | Adapter | 75003672 | 4 | 37 places/adapter |
| 3 | - | RIA or Round Bottom Tube (without cap) | - | - | 148 | 4500 | 4732 | 13 x 116 | Adapter | 75003724 | 4 | 37 places/adapter |
| | | | | | | | | | BIOLink Adapter | 75007304 | 4 | - |
| 4.5/6 ml | | Blood Collection Tube (Greiner™) | - | - | 164 | 5500 | 7068 | 14 x 110 | Adapter | 75003709 | 4 | 41 places/adapter |
| 5/7 ml | | Blood Collection Tube (BD) | - | - | 196 | 4500 | 4732 | 14 x 110 | Adapter | 75003671 | 4 | 49 places/adapter |
| 1.5-2.0 | | Conical Microtube | - | - | 192 | 5500 | 7068 | | Adapter | 75003733 | 4 | 48 places/adapter |
| | | | | | | | | | BIOLink Adapter | 75007304 | 4 | - |
| Micro-plates | | Standard Microplate | - | - | 24 | 5500 | 7068 | 86 x 128 | Adapter | 75007303 | | 6 places/adapter |
| Micro-plates | | Deep well Microplate | - | - | 8 | 5500 | 7068 | 86 x 128 | Adapter | 75007303 | | 2 places/adapter |
| Flasks | | T-75 Nunc Easy Flask | - | - | 4 | 2925 | 2000 | 11 x 50 | Adapter | 75008383 | 4 | 1 place/adapter |
| | | | | | | | | | BIOLink Adapter | 75007304 | 4 | - |
| Flasks | | T-25 Nunc Easy Flask | - | - | 8 | 2925 | 2000 | | Adapter | 75008384 | 4 | 1 place/adapter |
| | | | | | | | | | BIOLink Adapter | 75007304 | 4 | - |
| Blood Bags | - | Small Blood Bag/ Cell Culture Bags | - | - | - | 3600 | 3028 | | Adapter | 75003829 | 4 | 2 places/adapter |

Refer to manufacturer's recommendations for product performance information.

Table 18: BIOFlex HC rotor labware

6. 1. 6. Biocontainment Certificate

Health Protection Agency
Microbiology Services
Porton Down
Salisbury
Wiltshire
SP4 0JG



Certificate of Containment Testing

Containment Testing of Rotor BioFlex HC in a Thermo Scientific Centrifuge



Report No. 170-12 G

Report Prepared For: Thermo Fisher Scientific

Issue Date: 10th October 2012

Test Summary

A BioFlex HC rotor was containment tested in a Thermo Scientific centrifuge at 5,500 rpm, using Annex AA of IEC 1010-2-20:2006 (2nd Ed.). The sealed rotor was shown to contain all contents.

| | |
|--|---|
| Report Written By  Name: Ms Susan Macken Title: Biosafety Scientist | Report Authorised By  Name: Mrs Sara Speight Title: Senior Biosafety Scientist |
|--|---|

Thermo Scientific is a trademark of Thermo Fisher Scientific and is registered with the USPTO.

6.2. BIOFlex HS



6.2.1. Items Supplied

| Item | Cat. No. | Quantity |
|--|----------|----------|
| BIOFlex HS Rotor, including 4 Buckets | 75003002 | 1 |
| 400 mL Polypropylene Wide-Mouth Bio-Bottles (qty. 4) | 75007585 | 1 |
| Bolt Grease | 75003786 | 1 |
| Anti-corrosion Oil | 70009824 | 1 |

Table 19: Items supplied BIOFlex HS rotor

6.2.2. Technical Data

| | |
|-------------------------------|--|
| Type | Swinging Bucket |
| Material | Stainless Steel with Aluminum Buckets |
| Net Weight | 4.36 kg/9.6 lbs (Rotor Body) 7.64 kg/16.8 lbs (Rotor Body with Buckets) |
| Capacity | 4 x 1000 mL |
| Maximum Permissible Load | 4 x 600 g |
| Tube dimensions Ø x L | 80 x 125 mm |
| Maximum Number of Cycles | 30 000 |
| Radius (max. / min.) | 183 mm / 71 mm |
| Angle | 90° |
| Max. Autoclaving Temperature* | 121 °C |
| Aerosol-tight | Yes |

* Not autoclavable: O-Ring ClickSeal Lid (20058483).

Table 20: BIOFlex HS rotor technical data

6.2.3. Rotor Performance Data

| Centrifuge | LYNX 4000 | LYNX 6000 |
|--|---------------------------------------|---------------------------------------|
| Type | Swinging Bucket | Swinging Bucket |
| Material | Stainless Steel with Aluminum Buckets | Stainless Steel with Aluminum Buckets |
| Maximum Speed | 7 000 rpm | 7 000 rpm |
| Maximum RCF-Value | 10 025 x g | 10 025 x g |
| K-Factor at n_{max} | 4 889 | 4 889 |
| Acceleration / Braking Time | 40 s / 65 s | 40 s / 65 s |
| Maximum Speed at 4 °C | 7 000 rpm | 7 000 rpm |
| Min. Sample Temperature at Max. Speed (Ambient Temperature 23 °C, Run Time 60 minutes) | < 4 °C | -10 °C |

Table 21: BIOFlex HS rotor performance data

6. 2. 4. Accessories

| Description | Cat. No. | Max. speed (rpm) | Max. RCF ² (x g) |
|--|----------|------------------|-----------------------------|
| ClickSeal biocontainment lids (qty. 4) | 75003656 | - | - |
| O-Ring replacement kit for ClickSeal lids (qty. 4) | 75003657 | - | - |
| Rotor stand | 75003711 | - | - |
| Replacement BIOFlex HS buckets, set of 4 | 75003040 | - | - |
| Replacement O-Ring for biocontainment Cap for double biocontainment vessel for 50 mL conical tube (qty. 6) | 75003789 | - | - |

Table 22: BIOFlex HS rotor accessories

6. 2. 5. Labware

| Tube vol. (mL) | Vol. fill (mL) | Description | Cat. No. | Qty./pkg. | Tubes/rotor | Max. speed (rpm) | Max. RCF ² (x g) | Dims ØxL (mm) | Required tube closures, adapters, tools & accessories | | | |
|----------------|----------------|--|-----------|-----------|-------------|------------------|-----------------------------|---------------|---|-----------|---------------------|-----------------------------|
| | | | | | | | | | Type | Cat. No. | Qty./pkg. | Description |
| 400.0 | 400.0 | Polypropylene Bio-Bottle | 75007585 | 12 | 4 | 7000 | 10025 | 80 x 125 | - | - | - | - |
| 250.0 | 250.0 | Fiberlite PPCO Bottle | 010-1495 | 6 | 4 | 7000 | 10025 | 61 x 124 | Closure | Included | 6 | PPGF Cap w/ PP Plug |
| 250.0 | 250.0 | Fiberlite PC Bottle | 010-1496 | 6 | 4 | 7000 | 10025 | 61 x 124 | Closure | Included | 6 | PPGF Cap w/ PP Plug |
| 250.0 | 250.0 | Nunc Wide-Mouth Conical Bottle | 376814 | 40 | 4 | 7000 | 10025 | 60x144 | Adapter | 75004258 | 4 | 1 place/adapter |
| 250.0 | 250.0 | Nalgene PP Bottle | 3141-0250 | 36 | 4 | 7000 | 10025 | 62 x 135 | Adapter | 75004257 | 4 | 1 place/adapter |
| 250.0 | 250.0 | Nalgene PC Bottle | 3140-0250 | 36 | 4 | 7000 | 10025 | 62 x 135 | Adapter | 75004257 | 4 | 1 place/adapter |
| 225.0 | - | Falcon™ Conical Bottle | - | - | 4 | 4800 | 4700 | 62 x 130 | Adapter | 75004257 | 4 | 1 place/adapter |
| | | | | | | | | | Adapter | BD 352090 | Purchase Separately | 1 place/adapter |
| 200.0 | 200.0 | Nunc PP Conical Bottle | 376813 | 48 | 4 | 7000 | 10025 | 62 x 125 | Adapter | 75004258 | 4 | 1 place/adapter |
| 175.0 | 175.0 | Nalgene PP Wide-Mouth Conical Bottle | 3143-0175 | 36 | 4 | 7000 | 10025 | 62 x 125 | Adapter | 75004258 | 4 | 1 place/adapter |
| 175.0 | 175.0 | Nalgene PC Wide-Mouth Conical Bottle | 3144-0175 | 36 | 4 | 7000 | 10025 | 62 x 125 | Adapter | 75004258 | 4 | 1 place/adapter |
| 100.0 | - | Round Bottom Open-Top Tube | - | - | 4 | 4800 | 4700 | 45 x 117 | Adapter | 75003708 | 4 | 1 place/adapter |
| 50.0 | - | DIN Round Bottom Tube | - | - | 12 | 4800 | 4700 | 34.5 x 105 | Adapter | 75003707 | 4 | 3 places/ adapter |
| 50.0 | 42.0 | Nalgene PP Oak Ridge Tube | 3139-0050 | 100 | 16 | 7000 | 10025 | 28.5 x 114 | Adapter | 75003799 | 4 | 4 places/ adapter |
| 50.0 | 42.0 | Nalgene PC Oak Ridge Tube | 3138-0050 | 100 | 16 | 7000 | 10025 | 28.5 x 114 | Adapter | 75003799 | 4 | 4 places/ adapter |
| 50.0 | - | Conical Tissue Culture Tube | - | - | 16 | 4800 | 4700 | 29.5 x 116 | Adapter | 75003683 | 4 | 4 places/ adapter |
| 50.0 | - | Conical Tissue Culture Tube | - | - | 12 | 7000 | 10025 | 29.5 x 116 | Adapter | 75005393 | 4 | 3 places/ adapter |
| 50.0 | - | Double Biocontainment Vessels for 50 mL Conical Tube | - | - | 12 | 7000 | 10025 | 29.5 x 116 | Adapter | 75004259 | 2 | 2 places/ adapter |
| | | | | | | | | | Vessel | 75003787 | 1 | (2 included per 2 adapters) |

| Tube vol. (mL) | Vol. fill (mL) | Description | Cat. No. | Qty./pkg. | Tubes/rotor | Max. speed (rpm) | Max. RCF ² (x g) | Dims ØxL (mm) | Required tube closures, adapters, tools & accessories | | | |
|----------------|----------------|--|-----------|-----------|-------------|------------------|-----------------------------|---------------|---|----------|-----------|-------------------|
| | | | | | | | | | Type | Cat. No. | Qty./pkg. | Description |
| | | Nalgene Oak Ridge Tube | - | - | 12 | 7000 | 10025 | 1 x 30 | Adapter | 75005802 | 2 | 1 place/adapter |
| | | Nalgene Oak Ridge Tube | - | - | 12 | 7000 | 10025 | 1 x 16 | Adapter | 75005803 | 2 | 1 place/adapter |
| | | Conical Tissue Culture Tube | - | - | 12 | 7000 | 10025 | 1 x 15 | Adapter | 75005808 | 2 | 1 place/adapter |
| | | Blood Collection Tube | - | - | 12 | 7000 | 10025 | 1 x 10 | Adapter | 75005804 | 2 | 1 place/adapter |
| | | Blood Collection Tube | - | - | 12 | 7000 | 10025 | 1 x 7 | Adapter | 75005805 | 2 | 1 place/adapter |
| | | Blood Collection Tube (11 mm) | - | - | 24 | 7000 | 10025 | 2 x 3.5 | Adapter | 75005806 | 2 | 2 places/adapter |
| | | Microtube | - | - | 24 | 7000 | 10025 | 2 x 1.5/2 | Adapter | 75005807 | 2 | 2 places/adapter |
| 30.0 | - | DIN Round/Flat Bottom Tube | - | - | 20 | 7000 | 10025 | 25.5 x 108 | Adapter | 75003703 | 4 | 5 places/adapter |
| 20.0 | - | Round Bottom Tube | - | - | 12 | 4800 | 4700 | 25 x 110 | Adapter | 75003706 | 4 | 3 places/adapter |
| 16.0 | 16.0 | Nalgene PP Round Bottom Tube | 3139-0016 | 50 | 28 | 7000 | 10025 | 18 x 112 | Adapter | 75003798 | 4 | 7 places/adapter |
| 16.0 | 16.0 | Nalgene PC Round Bottom Tube | 3138-0016 | 50 | 28 | 7000 | 10025 | 18 x 112 | Adapter | 75003798 | 4 | 7 places/adapter |
| 15.0 | - | Conical Tissue Culture Tube | - | - | 36 | 7000 | 10025 | 17 x 121 | Adapter | 75005394 | 4 | 9 places/adapter |
| 15.0 | - | Blood Collection Tube (17 x 125 mm) | - | - | 16 | 4800 | 4700 | 15.5 x 131 | Adapter | 75003794 | 4 | 4 places/adapter |
| 15.0 | - | Round Bottom Tube (Sarstedt™) | - | - | 40 | 4800 | 4700 | 17 x 105 | Adapter | 75003704 | 4 | 10 places/adapter |
| 10/15 ml | - | Corex™/ Kimble™ Tube or 10 mL Blood Collection (BD Vacutainer™/ Vacuette™) | - | - | 56 | 7000 | 10025 | 17 x 113 | Adapter | 75003681 | 4 | 14 places/adapter |
| 5/7 ml | - | Blood Collection Tube (Vacutainer) | - | - | 76 | 4800 | 4700 | 13 x 110 | Adapter | 75003680 | 4 | 19 places/adapter |
| 4.5/6 ml | - | Blood Collection Tube (Greiner™) | - | - | 64 | 7000 | 10025 | 13 x 110 | Adapter | 75003825 | 4 | 16 places/adapter |
| 3/5 ml | - | RIA or Round Bottom Tube (without cap) | - | - | 76 | 7000 | 10025 | 11 x 110 | Adapter | 75003793 | 4 | 19 places/adapter |
| 1.5-2ml | - | Conical/Round Microtube | - | - | 136 | 7000 | 10025 | 11 x 45 | Adapter | 75003700 | 4 | 34 places/adapter |

Refer to manufacturer's recommendations for product performance information.

Table 23: BIOFlex HS rotor labware

6. 2. 6. Biocontainment Certificate

Health Protection Agency
Microbiology Services
Porton Down
Salisbury
Wiltshire
SP4 0JG



Certificate of Containment Testing

Containment Testing of Rotor BioFlex HS in a Thermo Scientific Centrifuge

Report No. 170-12 F

Report Prepared For: Thermo Fisher Scientific
Issue Date: 10th October 2012

Test Summary

A BioFlex HS rotor was containment tested in a Thermo Scientific centrifuge at 7,000 rpm, using Annex AA of IEC 1010-2-20:2006 (2nd Ed.). The sealed rotor was shown to contain all contents.

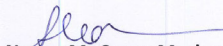
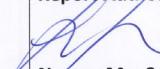
| | |
|--|---|
| Report Written By  Name: Ms Susan Macken Title: Biosafety Scientist | Report Authorised By  Name: Mrs Sara Speight Title: Senior Biosafety Scientist |
|--|---|

Thermo Scientific is a trademark of Thermo Fisher Scientific and is registered with the USPTO.

6.3. TH13-6x50



6.3.1. Items Supplied

| Item | Cat. No. | Quantity |
|---|-----------|----------|
| TH13-6x50 Rotor and biocontainment covers | 75003010 | 1 |
| 50 mL Nalgene PPCO Oak Ridge tube with sealing cap | 3139-0050 | 1 |
| Bolt Grease | 75003786 | 1 |
| O-Ring replacement kit (includes Grease for Bolts and Threads 76003500) | 75007002 | 1 |
| Anti-corrosion Oil | 70009824 | 1 |

Table 24: Items supplied TH13-6x50 rotor

6.3.2. Technical Data

| | |
|------------------------------|--------------------------------|
| Type | Swinging Bucket |
| Material | Aluminum with Titanium Buckets |
| Net Weight | 7.2 kg/15.8 lbs |
| Capacity | 6 x 50 mL |
| Maximum Permissible Load | 6 x 80 g |
| Tube Dimensions Ø x L | 29 x 104 mm |
| Maximum Number of Cycles | 30 000 |
| Radius (max. / min.) | 158 mm / 57 mm |
| Angle | 90° |
| Max. Autoclaving Temperature | 121 °C |
| Aerosol-tight | Yes |

Table 25: TH13-6x50 rotor technical data

6.3.3. Rotor Performance Data

| Centrifuge | LYNX 4000 | LYNX 6000 |
|--|-------------|-------------|
| Maximum Speed | 13 100 rpm | 13 100 rpm |
| Maximum RCF-Value (158 mm radius) | 30 314 x g | 30 314 x g |
| Minimum RCF-Value (57 mm radius) | 10 936 x g | 10 936 x g |
| K-Factor at n_{max} | 1 503 | 1 503 |
| Acceleration / Braking Time | 50 s / 70 s | 45 s / 75 s |
| Maximum Speed at 4 °C | 13 100 rpm | 13 100 rpm |
| Min. Sample Temperature at Max. Speed (Ambient Temperature 23 °C, Run Time 60 minutes) | 0 °C | -2 °C |

Table 26: TH13-6x50 rotor performance data

6.3.4. Accessories

| Description | Cat. No. | Max. speed (rpm) | Max. RCF ² (x g) |
|---|----------|------------------|-----------------------------|
| Replacement biocontainment covers (each) | 50129119 | - | - |
| Replacement O-Rings TH13-6x50 buckets, set of 6 | 75007002 | - | - |

Table 27: TH13-6x50 rotor accessories

6.3.5. Labware

| Tube vol. (mL) | Vol. fill (mL) | Description | Cat. No. | Qty./pkg. | Tubes/rotor | Max. speed (rpm) | Max. RCF ² (x g) | Dims ØxL (mm) | Required tube closures, adapters, tools & accessories | | | |
|----------------|----------------|------------------------------------|-----------|-----------|-------------|------------------|-----------------------------|---------------|---|----------|-----------|-----------------|
| | | | | | | | | | Type | Cat. No. | Qty./pkg. | Description |
| 50.0 | | PA Thin-Walled Tube | 03139 | 25 | 6 | 13100 | 30314 | 28 x 104 | - | - | - | - |
| 50.0 | 50.0 | Nunc PP Conical Tube | 339650 | 25 | 6 | - | - | - | Adapter | 75004264 | 1 | 1 place/adapter |
| 50.0 | 50.0 | Falcon™ PP Conical Tube | - | - | 6 | 13100 | 30314 | - | Adapter | 75004264 | 1 | 1 place/adapter |
| 50.0 | 50.0 | Corning™ Conical Tube | - | - | 6 | 13100 | 30314 | - | Adapter | 75004264 | 1 | 1 place/adapter |
| 50.0 | 50.0 | Sarstedt™ Conical Tube | - | - | 6 | 13100 | 30314 | - | Adapter | 75004264 | 1 | 1 place/adapter |
| 50.0 | 50.0 | Sterilin™ PP Conical Tube | - | - | 6 | 13100 | 30314 | - | Adapter | 75004264 | 1 | 1 place/adapter |
| 50.0 | 50.0 | Conical Filter Tube (e.g. Amicon™) | - | - | 6 | - | - | - | Adapter | 75004264 | 1 | 1 place/adapter |
| 50.0 | 50.0 | Greiner™ Conical Tube | - | - | 6 | 13100 | 30314 | - | Adapter | 75004264 | 1 | 1 place/adapter |
| 50.0 | 48.0 | PC Flanged Tube | 03146 | 25 | 6 | 13100 | 30314 | 29 x 102 | Closure | 03268 | 25 | PP Snap-on |
| 50.0 | 46.0 | PP Flanged Tube | 03147 | 25 | 6 | 13100 | 30314 | 29 x 102 | Closure | 03268 | 25 | PP Snap-on |
| 50.0 | 43.0 | Nalgene PC Oak Ridge Tube | 3118-0050 | 100 | 6 | 13100 | 30314 | 29 x 107 | Closure | Included | 100 | PP Screw Top |
| 50.0 | 43.0 | Nalgene PPCO Oak Ridge Tube | 3119-0050 | 50 | 6 | 13100 | 30314 | 29 x 107 | Closure | Included | 100 | PP Screw Top |
| 50.0 | 43.0 | Nalgene PC Oak Ridge Tube | 3138-0050 | 50 | 6 | 13100 | 30314 | 29 x 107 | Closure | Included | 50 | PP Sealing |
| 50.0 | 43.0 | Nalgene PPCO Oak Ridge Tube | 3139-0050 | 50 | 6 | 13100 | 30314 | 29 x 107 | Closure | Included | 50 | PP Sealing |
| 16.0 | 16.0 | PP Flanged Tube | 03244 | 50 | 6 | 13100 | 30314 | 18 x 100 | Closure | 03299 | 50 | PP Snap-on |
| | | | | | | | | | Adapter | 75003026 | 2 | 1 place/adapter |
| 15.0 | 15.0 | Nunc PP Conical Tube | 339650 | 50 | 6 | - | - | - | Adapter | 75007321 | 2 | 1 place/adapter |
| 15.0 | 15.0 | Greiner™ Conical Tube | - | - | 6 | 13100 | 30314 | - | Adapter | 75007321 | 2 | 1 place/adapter |
| 15.0 | 15.0 | Falcon™ PP Conical Tube | - | - | 6 | 13100 | 30314 | - | Adapter | 75007321 | 2 | 1 place/adapter |
| 15.0 | 15.0 | Corning™ Conical Tube | - | - | 6 | 13100 | 30314 | - | Adapter | 75007321 | 2 | 1 place/adapter |
| 15.0 | 15.0 | Sarstedt PP Conical Tube | - | - | 6 | 13100 | 30314 | - | Adapter | 75007321 | 2 | 1 place/adapter |
| 15.0 | 15.0 | Sterilin™ PP Conical Tube | - | - | 6 | 13100 | 30314 | - | Adapter | 75007321 | 2 | 1 place/adapter |

| Tube vol. (mL) | Vol. fill (mL) | Description | Cat. No. | Qty./pkg. | Tubes/rotor | Max. speed (rpm) | Max. RCF ² (x g) | Dims ØxL (mm) | Required tube closures, adapters, tools & accessories | | | |
|----------------|----------------|------------------------------------|-----------|-----------|-------------|------------------|-----------------------------|---------------|---|----------|-----------|------------------|
| | | | | | | | | | Type | Cat. No. | Qty./pkg. | Description |
| 15.0 | 15.0 | Conical Filter Tube (e.g. Amicon™) | - | - | 6 | - | - | - | Adapter | 75007321 | 2 | 1 place/adapter |
| 14.0 | 11.0 | PC Flanged Tube | 03246 | 50 | 12 | 13100 | 30314 | 18 x 75 | Closure | 03269 | 50 | PP Snap-on |
| | | | | | | | | | Adapter | 75003025 | 2 | 1 place/adapter |
| 12.0 | 12.0 | PP Flanged Tube | 03116 | 50 | 6 | 13100 | 30314 | 16 x 100 | Closure | 03266 | 50 | PP Snap-on |
| | | | | | | | | | Adapter | 75003028 | 2 | 1 place/adapter |
| 12.0 | 12.0 | PC Flanged Tube | 03115 | 50 | 6 | 13100 | 30314 | 16 x 100 | Closure | 75003028 | 50 | PP Snap-on |
| | | | | | | | | | Adapter | 00367 | 2 | 1 place/adapter |
| 10.0 | - | Pyrex™ Graduated Conical Tube | - | - | 6 | 5000 | 4416 | 18 x 100 | Adapter | 00367 | 1 | 1 place/adapter |
| 10.0 | 9.7 | PC Oak Ridge Tube | 03020 | 50 | 6 | 13100 | 30314 | 16 x 83 | Closure | 03279 | 25 | PP Sealing |
| | | | | | | | | | Closure | 03924 | 25 | PP Screw Top |
| | | | | | | | | | Adapter | 75003024 | 2 | 1 place/adapter |
| 10.0 | 9.1 | PP Oak Ridge Tube | 03929 | 50 | 6 | 13100 | 30314 | 16 x 83 | Closure | 03279 | 25 | PP Sealing |
| | | | | | | | | | Closure | 03924 | 25 | PP Screw Top |
| | | | | | | | | | Adapter | 75003024 | 2 | 1 place/adapter |
| 7.0 | 7.0 | PC Flanged Tube | 03120 | 50 | 6 | 13100 | 30314 | 13 x 100 | Closure | 03265 | 50 | PP Snap-on |
| | | | | | | | | | Adapter | 00473 | 1 | 1 place/adapter |
| 7.0 | 7.0 | PP Flanged Tube | 03121 | 50 | 6 | 13100 | 30314 | 13 x 100 | Closure | 03265 | 50 | PP Snap-on |
| | | | | | | | | | Adapter | 00473 | 1 | 1 place/adapter |
| 4.0 | 4.0 | PP Flanged Tube | 03105 | 50 | 12 | 13100 | 30314 | 11 x 75 | Closure | 03264 | 50 | PP Snap-on |
| | | | | | | | | | Adapter | 00473 | 1 | 1 place/adapter |
| 4.0 | 4.0 | PC Flanged Tube | 03104 | 50 | 12 | 13100 | 30314 | 11 x 75 | Closure | 03264 | 50 | PP Snap-on |
| | | | | | | | | | Adapter | 75003023 | 2 | 2 places/adapter |
| 1.5 | 1.5 | Polyallomer Microtube | 314352H01 | 100 | 18 | 10100 | 18112 | 11 x 40 | Adapter | 75003029 | 2 | 3 places/adapter |
| 1.0 | 1.0 | Cellulose (Acetate Butyrate) Tube | 03103 | 50 | 24 | 13100 | 30314 | 7 x 50 | Adapter | 00408 | 1 | 4 places/adapter |

Refer to manufacturer's recommendations for product performance information.

Table 28: TH13-6x50 rotor labware

6. 3. 6. Biocontainment Certificate

Health Protection Agency
Microbiology Services
Porton Down
Salisbury
Wiltshire
SP4 0JG



Certificate of Containment Testing



Containment Testing of Rotor TH13-6x50 in a Thermo Scientific Centrifuge

Report No. 170-12 E

Report Prepared For: Thermo Fisher Scientific
Issue Date: 10th October 2012

Test Summary

A TH13-6x50 rotor was containment tested in a Thermo Scientific centrifuge at 13,100 rpm at partial vacuum, using Annex AA of IEC 1010-2-20:2006 (2nd Ed.). The sealed rotor was shown to contain all contents.

| Report Written By | Report Authorised By |
|--|--|
|  Name: Ms Susan Macken Title: Biosafety Scientist |  Name: Mrs Sara Speight Title: Senior Biosafety Scientist |

Thermo Scientific is a trademark of Thermo Fisher Scientific and is registered with the USPTO.

6.4. T29-8x50



6.4.1. Items Supplied

| Item | Cat. No. | Quantity |
|---|-----------|----------|
| T29-8x50 Rotor | 75003009 | 1 |
| 50 mL Nalgene PPCO Oak Ridge tube with sealing cap | 3139-0050 | 8 |
| Anti-corrosion Oil | 70009824 | 1 |
| Bolt Grease | 75003786 | 1 |
| O-Ring replacement kit (includes Grease for Bolts and Threads 76003500) | 75007009 | 1 |
| Retaining ring pliers | 65614 | 1 |

Table 29: Items supplied T29-8x50 rotor

6.4.2. Technical Data

| | |
|------------------------------|----------------|
| Type | Fixed angle |
| Material | Titanium |
| Net Weight | 8.4 kg/18.5 lb |
| Capacity | 8 x 50 mL |
| Maximum Permissible Load | 8 x 75 g |
| Maximum Number of Cycles | 50 000 |
| Radius (max. / min.) | 107 mm / 33 mm |
| Angle | 34° |
| Max. Autoclaving Temperature | 121 °C |
| Aerosol-tight | Yes |

Table 30: T29-8x50 rotor technical data

6.4.3. Rotor Performance Data

| Centrifuge | LYNX 4000 | LYNX 6000 |
|--|--------------|--------------|
| Maximum Speed | 24 000 rpm | 29 000 rpm |
| Maximum RCF-Value | 68 905 x g | 100 605 x g |
| K-Factor at n_{max} | 354 | 354 |
| Acceleration / Braking Time | 90 s / 105 s | 70 s / 110 s |
| Maximum Speed at 4 °C | 22 500 rpm | 24 200 rpm |
| Min. Sample Temperature at Max. Speed (Ambient Temperature 23 °C, Run Time 60 minutes) | 7 °C | 19 °C |

Table 31: T29-8x50 rotor performance data

6. 4. 4. Accessories

| Description | Cat. No. | Max. speed (rpm) | Max. RCF ² (x g) |
|---|----------|------------------|-----------------------------|
| Ultracrimp sealing tool and crimp gauge | 03920 | - | - |
| Ultracrimp gauge replacement | 03919 | - | - |
| Extra ultracrimp plugs and caps | 03999 | - | - |
| Rotor cap | 03538 | - | - |
| Rotor stand | 75003711 | - | - |

Table 32: T29-8x50 rotor accessories

6. 4. 5. Labware

| Tube vol. (mL) | Vol. fill (mL) | Description | Cat. No. | Qty./pkg. | Tubes/rotor | Max. speed (rpm) | Max. RCF ² (x g) | Dims ØxL (mm) | Required tube closures, adapters, tools & accessories | | | |
|----------------|----------------|-----------------------------------|-----------|-----------|-------------|------------------|-----------------------------|---------------|---|----------|-----------|-------------------------|
| | | | | | | | | | Type | Cat. No. | Qty./pkg. | Description |
| 50.0 | 50.0 | PA Ultracrimp Tube | 03528 | 25 | 8 | 29000 | 100605 | 29 x 108 | Closure | Included | 25 | Plugs and Aluminum Caps |
| | | | | | | | | | Accessory | 03538 | 1 | Rotor cap |
| | | | | | | | | | Accessory | 03529 | 2 | Tube Racks |
| | | | | | | | | | Accessory | 03920 | 1 | Crimp Sealing Tool |
| 50.0 | 37.0 | PP Flanged Tube | 03147 | 25 | 8 | 29000 | 100605 | 29 x 102 | Closure | 03268 | 25 | PP Snap-on |
| 50.0 | 36.0 | PC Flanged Tube | 03146 | 25 | 8 | 29000 | 100605 | 29 x 102 | Closure | 03268 | 25 | PP Snap-on |
| 50.0 | 46.0 | PA Thin-Walled Tube | 03139 | 25 | 8 | 21000 | 52755 | 28 x 104 | - | - | - | - |
| 50.0 | 46.0 | Nalgene FEP Oak Ridge Tube | 3114-0050 | 10 | 8 | 21000 | 52755 | 28 x 108 | Closure | Included | 10 | FEP Sealing |
| 50.0 | 43.0 | Nalgene PC Oak Ridge Style Tube | 3138-0050 | 50 | 8 | 29000 | 100605 | 29 x 107 | Closure | Included | 50 | PP Sealing |
| 50.0 | 43.0 | Nalgene PPCO Oak Ridge Style Tube | 3139-0050 | 50 | 8 | 29000 | 100605 | 29 x 107 | Closure | Included | 50 | PP Sealing |
| 30.0 | 28.0 | Nalgene PC Oak Ridge Tube | 3138-0030 | 50 | 8 | 29000 | 100605 | 26 x 102 | Closure | Included | 50 | PP Sealing |
| | | | | | | | | | Adapter | 75003027 | 2 | 1 place/adapter |
| 30.0 | 28.0 | Nalgene PP Oak Ridge Tube | 3139-0030 | 50 | 8 | 29000 | 100605 | 26 x 102 | Closure | Included | 50 | PP Sealing |
| | | | | | | | | | Adapter | 75003027 | 2 | 1 place/adapter |
| 30.0 | - | Glass Tube | - | - | 8 | - | - | 24 x 106 | Adapter | 00368 | 1 | Optional Caps |
| 16.0 | 16.0 | Nalgene PC Oak Ridge Tube | 3138-0016 | 50 | 8 | 29000 | 100605 | - | Closure | Included | 1 | PA Sealing |
| | | | | | | | | | Adapter | 75003026 | 2 | 1 place/adapter |
| 16.0 | 16.0 | Nalgene PP Oak Ridge Tube | 3139-0016 | 50 | 8 | 29000 | 100605 | - | Closure | Included | 1 | PA Sealing |
| | | | | | | | | | Adapter | 75003026 | 2 | 1 place/adapter |

| Tube vol. (mL) | Vol. fill (mL) | Description | Cat. No. | Qty./pkg. | Tubes/rotor | Max. speed (rpm) | Max. RCF ² (x g) | Dims ØxL (mm) | Required tube closures, adapters, tools & accessories | | | |
|----------------|----------------|---------------------------|-----------|-----------|-------------|------------------|-----------------------------|---------------|---|----------|-----------|------------------|
| | | | | | | | | | Type | Cat. No. | Qty./pkg. | Description |
| 16.0 | 13.0 | PP Flanged Tube | 03244 | 50 | 8 | 29000 | 100605 | 18 x 100 | Closure | 03299 | 50 | HDPE Sealing |
| | | | | | | | | | Adapter | 75003026 | 2 | 1 place/adapter |
| 15.0 | 15.0 | Conical Tube | - | - | 8 | - | - | - | Adapter | 75007321 | 2 | 1 place/adapter |
| 14.0 | 11.0 | PC Flanged Tube | 03246 | 50 | 12 | 29000 | 100605 | 18 x 75 | Closure | 03269 | 50 | PP Snap-on |
| | | | | | | | | | Adapter | 75003025 | 2 | 1 place/adapter |
| 12.0 | 10.0 | PP Flanged Tube | 03116 | 50 | 8 | 29000 | 100605 | 16 x 100 | Closure | 03266 | 50 | PP Snap on |
| | | | | | | | | | Adapter | 75003028 | 2 | 1 place/adapter |
| 12.0 | 11.0 | PC Flanged Tube | 03115 | 50 | 8 | 29000 | 100605 | 16 x 100 | Closure | 03266 | 50 | PP Snap on |
| | | | | | | | | | Adapter | 75003028 | 2 | 1 place/adapter |
| 10.0 | 10.0 | Nalgene PC Oak Ridge Tube | 3138-0010 | 50 | 8 | 29000 | 100605 | - | Closure | Included | 1 | PA Sealing |
| | | | | | | | | | Adapter | 75003024 | 2 | 1 place/adapter |
| 10.0 | 10.0 | Nalgene PP Oak Ridge Tube | 3139-0010 | 50 | 8 | 29000 | 100605 | - | Closure | Included | 1 | PA Sealing |
| | | | | | | | | | Adapter | 75003024 | 2 | 1 place/adapter |
| 10.0 | 9.1 | PP Oak Ridge Tube | 03929 | 50 | 8 | 29000 | 100605 | 16 x 80 | Closure | 03279 | 25 | PP Snap on |
| | | | | | | | | | Adapter | 75003024 | 2 | 1 place/adapter |
| 10.0 | 9.1 | PC Oak Ridge Tube | 03020 | 25 | 8 | 29000 | 100605 | 16 x 80 | Closure | 03279 | 25 | PP Sealing |
| | | | | | | | | | Adapter | 75003024 | 2 | 1 place/adapter |
| 7.0 | 6.0 | PC Flanged Tube | 03120 | 50 | 8 | 21000 | 52755 | 13 x 100 | Closure | 03265 | 50 | PP Snap-On |
| | | | | | | | | | Adapter | 00473 | 1 | 1 place/adapter |
| 7.0 | 6.0 | PP Flanged Tube | 03121 | 50 | 8 | 21000 | 52755 | 13 x 100 | Closure | 03265 | 50 | PP Snap-On |
| | | | | | | | | | Adapter | 00473 | 1 | 1 place/adapter |
| 4.0 | 3.0 | PP Flanged Tube | 03105 | 50 | 8 | 29000 | 100605 | 11 x 75 | Closure | 03264 | 50 | PP Snap-On |
| | | | | | | | | | Adapter | 75003023 | 2 | 2 place/adapter |
| 4.0 | 3.0 | PC Flanged Tubes | 03104 | 50 | 16 | 29000 | 100605 | 11 x 75 | Closure | 03264 | 50 | PP Snap-On |
| | | | | | | | | | Adapter | 75003023 | 2 | 2 place/adapter |
| 1.5 | 1.5 | Polyallomer Microtube | 314352H01 | 100 | 24 | 22600 | 61492 | 11 x 40 | Adapter | 75003029 | 2 | 3 places/adapter |

Refer to manufacturer's recommendations for product performance information.

Table 33: T29-8x50 rotor labware

6. 4. 6. Biocontainment Certificate

Health Protection Agency
Microbiology Services
Porton Down
Salisbury
Wiltshire
SP4 0JG



Certificate of Containment Testing

Containment Testing of Rotor T29-8x50 in a Thermo Scientific Centrifuge

Report No. 170-12 I

Report Prepared For: Thermo Fisher Scientific
Issue Date: 10th October 2012

Test Summary

A T29-8x50 rotor was containment tested in a Thermo Scientific centrifuge at 29,000 rpm at partial vacuum, using Annex AA of IEC 1010-2-20:2006 (2nd Ed.). The sealed rotor was shown to contain all contents.

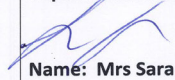
| | |
|--|---|
| Report Written By  Name: Ms Anna Moy Title: Biosafety Scientist | Report Authorised By  Name: Mrs Sara Speight Title: Senior Biosafety Scientist |
|--|---|

Thermo Scientific is a trademark of Thermo Fisher Scientific and is registered with the USPTO.

6.5. A21-24x15c



6.5.1. Items Supplied

| Item | Cat. No. | Quantity |
|---|----------|----------|
| A21-24x15 Rotor | 75003004 | 1 |
| Bolt Grease | 75003786 | 1 |
| Anti-corrosion Oil | 70009824 | 1 |
| O-Ring replacement kit (includes Grease for Bolts and Threads 76003500) | 75007003 | 1 |
| Retaining Ring Pliers | 65614 | 1 |

Table 34: Items supplied A21-24x15c rotor

6.5.2. Technical Data

| | |
|--------------------------------|------------------|
| Type | Fixed angle |
| Material | Aluminum |
| Net Weight | 8.7 kg /19.1 lbs |
| Capacity | 24 x 15 mL |
| Maximum Permissible Load | 24 x 27 g |
| Tube Dimensions Ø x L | 121.5 x 16.5 mm |
| Maximum Number of Cycles | 50 000 |
| Inner Row Radius (max. / min.) | 122 mm / 44 mm |
| Outer Row Radius (max. / min.) | 122 mm / 61 mm |
| Inner Row Angle | 42° |
| Outer Row Angle | 30° |
| Max. Autoclaving Temperature | 121 °C |
| Aerosol-tight | Yes |

Table 35: A21-24x15c rotor technical data

6.5.3. Rotor Performance Data

| Centrifuge | LYNX 4000 | LYNX 6000 |
|--|--------------|-------------|
| Maximum Speed | 19 500 rpm | 21 500 rpm |
| Maximum RCF-Value | 51 865 x g | 63 049 x g |
| K-Factor at n_{max} | 379 | 379 |
| Acceleration / Braking Time | 95 s / 100 s | 80 s / 95 s |
| Maximum Speed at 4 °C | 18 000 rpm | 20 500 rpm |
| Min. Sample Temperature at Max. Speed (Ambient Temperature 23 °C, Run Time 60 minutes) | 7 °C | 10 °C |

Table 36: A21-24x15c rotor performance data

6.5.4. Accessories

| Description | Cat. No. | Max. speed (rpm) | Max. RCF ² (x g) |
|--------------------|----------|------------------|-----------------------------|
| Rotor stand | 75003711 | - | - |
| Replacement O-Ring | 75007003 | - | - |

Table 37: A21-24x15c rotor accessories

6.5.5. Labware

| Tube vol. (mL) | Vol. fill (mL) | Description | Cat. No. | Qty./pkg. | Tubes/rotor | Max. speed (rpm) | Max. RCF ² (x g) | Dims ØxL (mm) | Required tube closures, adapters, tools & accessories | | | |
|----------------|----------------|---|----------|-----------|-------------|------------------|-----------------------------|---------------|---|----------|-----------|-------------|
| | | | | | | | | | Type | Cat. No. | Qty./pkg. | Description |
| 15.0 | 15.0 | Nunc PP Conical Disposable Tube ¹ | 339651 | 500 | 24 | 11600 | 18500 | - | Closure | Included | - | - |
| 15.0 | 15.0 | Greiner™ PP Conical Disposable Tube ¹ | - | - | 24 | 21500 | 63049 | - | Closure | Included | - | - |
| 15.0 | 15.0 | Greiner™ Conical Disposable Tube ¹ | - | - | 24 | 21500 | 63049 | - | Closure | Included | - | - |
| 15.0 | 15.0 | Falcon™ PP Conical Disposable Tube ¹ | - | - | 24 | 21500 | 63049 | - | Closure | Included | - | - |
| 15.0 | 15.0 | Corning™ PP Conical Disposable Tube ¹ | - | - | 24 | 21500 | 63049 | - | Closure | Included | - | - |
| 15.0 | 15.0 | Corning™ PET Conical Disposable Tube ¹ | - | - | 24 | 21500 | 63049 | - | Closure | Included | - | - |
| 15.0 | 15.0 | Sarstedt™ PP Conical Disposable Tube ¹ | - | - | 24 | 21500 | 63049 | - | Closure | Included | - | - |

Refer to manufacturer's recommendations for product performance information.

Table 38: A21-24x15c rotor labware

6. 5. 6. Biocontainment Certificate

Health Protection Agency
Microbiology Services
Porton Down
Salisbury
Wiltshire
SP4 0JG



Certificate of Containment Testing

Containment Testing of Rotor A21-24x15c in a Thermo Scientific Centrifuge

Report No. 170-12 B

Report Prepared For: Thermo Fisher Scientific
Issue Date: 10th October 2012

Test Summary

An A21-24x15c rotor was containment tested in a Thermo Scientific centrifuge at 21,500 rpm at partial vacuum, using Annex AA of IEC 1010-2-20:2006 (2nd Ed.). The sealed rotor was shown to contain all contents.

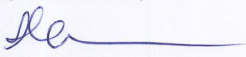
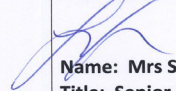
| | |
|--|---|
| Report Written By  Name: Ms Susan Macken Title: Biosafety Scientist | Report Authorised By  Name: Mrs Sara Speight Title: Senior Biosafety Scientist |
|--|---|

Thermo Scientific is a trademark of Thermo Fisher Scientific and is registered with the USPTO.

6.6. A22-24x16



6.6.1. Items Supplied

| Item | Cat. No. | Quantity |
|---|-----------|----------|
| A22-24x16 Rotor | 75003005 | 1 |
| 16 mL Nalgene PPCO Oak Ridge tube with sealing cap | 3139-0016 | 24 |
| O-ring replacement kit (includes Grease for Bolts and Threads 76003500) | 75007003 | 1 |
| Bolt Grease | 75003786 | 1 |
| Anti-corrosion Oil | 70009824 | 1 |
| Retaining ring pliers | 65614 | 1 |

Table 39: Items supplied A22-24x16 rotor

6.6.2. Technical Data

| | |
|--------------------------------|------------------|
| Type | Fixed angle |
| Material | Aluminum |
| Net Weight | 7.7 kg /17.0 lbs |
| Capacity | 24 x 16 mL |
| Maximum Permissible Load | 24 x 16 g |
| Maximum Number of Cycles | 50 000 |
| Inner Row Radius (max. / min.) | 111 mm / 39 mm |
| Outer Row Radius (max. / min.) | 111 mm / 54 mm |
| Inner Row Angle | 28° |
| Outer Row Angle | 42° |
| Max. Autoclaving Temperature | 121 °C |
| Aerosol-tight | Yes |

Table 40: A22-24x16 rotor technical data

6.6.3. Rotor Performance Data

| Centrifuge | LYNX 4000 | LYNX 6000 |
|--|-------------|-------------|
| Maximum Speed | 22000 rpm | 22000 rpm |
| Maximum RCF-Value | 60063 x g | 60063 x g |
| K-Factor at n_{max} | 377 | 377 |
| Acceleration / Braking Time | 85 s / 90 s | 60 s / 85 s |
| Maximum Speed at 4 °C | 20500 rpm | 21800 rpm |
| Min. Sample Temperature at Max. Speed (Ambient Temperature 23 °C, Run Time 60 minutes) | 9 °C | 5 °C |

Table 41: A22-24x16 rotor performance data

6. 6. 4. Accessories

| Description | Cat. No. | Max. speed (rpm) | Max. RCF ² (x g) |
|-------------|----------|------------------|-----------------------------|
| Rotor Stand | 75003711 | - | - |

Table 42: A22-24x16 rotor accessories

6. 6. 5. Labware

| Tube vol. (mL) | Vol. fill (mL) | Description | Cat. No. | Qty./pkg. | Tubes/rotor | Max. speed (rpm) | Max. RCF ² (x g) | Dims ØxL (mm) | Required tube closures, adapters, tools & accessories | | | |
|--|----------------|-----------------------------|-----------|-----------|-------------|------------------|-----------------------------|---------------|---|----------|-----------|-----------------|
| | | | | | | | | | Type | Cat. No. | Qty./pkg. | Description |
| 16.0 | 13.0 | PP Flanged Tube | 03244 | 50 | 24 | 22000 | 60063 | 18 x 100 | Closure | 03299 | 50 | PP Snap-on |
| 16.0 | 16.0 | Nalgene PC Oak Ridge Tube | 3138-0016 | 50 | 24 | 22000 | 60063 | 18 x 107 | Closure | Included | - | PP Sealing |
| | | | | | | | | | | | | |
| 16.0 | 16.0 | Nalgene PPCO Oak Ridge Tube | 3139-0016 | 50 | 24 | 22000 | 60063 | 18 x 107 | Closure | Included | - | PP Sealing |
| | | | | | | | | | | | | |
| 7.0 | 6.0 | PC Flanged Tube | 03120 | 50 | 24 | 22000 | 60063 | 13 x 100 | Closure | 03265 | 50 | PP Snap-on |
| | | | | | | | | | Adapter | 00416 | 1 | 1 place/adapter |
| 7.0 | 6.0 | PP Flanged Tube | 03121 | 50 | 24 | 22000 | 60063 | 13 x 100 | Closure | 03265 | 50 | PP Snap-on |
| | | | | | | | | | Adapter | 00416 | 1 | 1 place/adapter |
| 5.0 | 5.0 | Pyrex™ Tube | 03102 | 50 | 24 | 5000 | 3102 | 12 x 75 | Adapter | 00376 | 1 | 1 place/adapter |
| 1.5 | 1.5 | Polyallomer Microtube | 314352H01 | 100 | 24 | 22000 | 60063 | 11 x 40 | Adapter | 00376 | 1 | 1 place/adapter |
| Refer to manufacturer's recommendations for product performance information. | | | | | | | | | | | | |

Table 43: A22-24x16 rotor labware

6. 6. 6. Biocontainment Certificate

Health Protection Agency
Microbiology Services
Porton Down
Salisbury
Wiltshire
SP4 0JG



Certificate of Containment Testing

Containment Testing of Rotor A22-24x16 in a Thermo Scientific Centrifuge

Report No. 170-12 A

Report Prepared For: Thermo Fisher Scientific

Issue Date: 10th October 2012

Test Summary

An A22-24x16 rotor was containment tested in a Thermo Scientific centrifuge at 22,000 rpm at partial vacuum, using Annex AA of IEC 1010-2-20:2006 (2nd Ed.). The sealed rotor was shown to contain all contents.

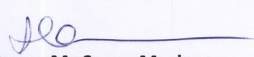
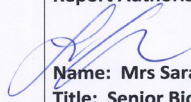
| | |
|--|---|
| Report Written By  Name: Ms Susan Macken Title: Biosafety Scientist | Report Authorised By  Name: Mrs Sara Speight Title: Senior Biosafety Scientist |
|--|---|

Thermo Scientific is a trademark of Thermo Fisher Scientific and is registered with the USPTO.

6.7. A23-6x100



6.7.1. Items Supplied

| Item | Cat. No. | Quantity |
|---|-----------|----------|
| A23-6x100 Rotor | 75003006 | 1 |
| 85 mL Nalgene PPCO Oak Ridge tube with sealing cap | 3118-0085 | 6 |
| O-Ring replacement kit (includes Grease for Bolts and Threads 76003500) | 75007004 | 1 |
| Bolt Grease | 75003786 | 1 |
| Anti-corrosion Oil | 70009824 | 1 |
| Retaining ring pliers | 65614 | 1 |

Table 44: Items supplied A23-6x100 rotor

6.7.2. Technical Data

| | |
|------------------------------|------------------|
| Type | Fixed angle |
| Material | Aluminum |
| Net Weight | 7.2 kg /15.8 lbs |
| Capacity | 6 x 100 mL |
| Maximum Permissible Load | 6 x 150 g |
| Tube Dimensions Ø x L | 38.0 x 105.0 mm |
| Maximum Number of Cycles | 50 000 |
| Radius (max. / min.) | 102 mm / 34 mm |
| Angle | 25° |
| Max. Autoclaving Temperature | 121 °C |
| Aerosol-tight | Yes |

Table 45: A23-6x100 rotor technical data

6.7.3. Rotor Performance Data

| Centrifuge | LYNX 4000 | LYNX 6000 |
|--|-------------|-------------|
| Maximum Speed | 21 000 rpm | 23 500 rpm |
| Maximum RCF-Value | 50 290 x g | 63 513 x g |
| K-Factor at n_{max} | 503 | 503 |
| Acceleration / Braking Time | 60 s / 80 s | 60 s / 85 s |
| Maximum Speed at 4 °C | 21 000 rpm | 23 500 rpm |
| Min. Sample Temperature at Max. Speed (Ambient Temperature 23 °C, Run Time 60 minutes) | -1 °C | 3 °C |

Table 46: A23-6x100 rotor performance data

6.7.4. Accessories

| Description | Cat. No. | Max. speed (rpm) | Max. RCF ² (x g) |
|-------------|----------|------------------|-----------------------------|
| Rotor Stand | 75003711 | - | - |

Table 47: A23-6x100 rotor accessories

6.7.5. Labware

| Tube vol. (mL) | Vol. fill (mL) | Description | Cat. No. | Qty./pkg. | Tubes/rotor | Max. speed (rpm) | Max. RCF ² (x g) | Dims ØxL (mm) | Required tube closures, adapters, tools & accessories | | | |
|----------------|----------------|-----------------------------|-----------|-----------|-------------|------------------|-----------------------------|---------------|---|----------|-----------|---------------------------|
| | | | | | | | | | Type | Cat. No. | Qty./pkg. | Description |
| 94.0 | 70.0 | PP Thick-Walled Tube | 76002872 | 1 | 6 | 23500 | 62976 | 38 x 105 | Closure | 75001568 | 1 | Sealing Cap |
| 94.0 | 70.0 | PC Screw Cap Tube | 75002829 | 1 | 6 | 23500 | 62976 | 38 x 105 | Closure | 75001540 | 1 | Sealing Cap |
| 94.0 | 70.0 | PC Screw Cap Tube | 75002810 | 1 | 6 | 23500 | 62976 | 38 x 105 | Closure | 75001568 | 1 | Sealing Cap |
| 85.0 | 71.0 | Nalgene PC Oak Ridge Tube | 3118-0085 | 100 | 6 | 23500 | 62976 | 29 x 114 | Closure | Included | 100 | PP Sealing Cap |
| 50.0 | 37.0 | PP Flanged Tube | 03147 | 25 | 6 | 23500 | 62976 | 29 x 102 | Closure | 03268 | 25 | PP Snap-on |
| | | | | | | | | | Adapter | 75003102 | 1 | 1 place/adapter |
| 50.0 | 36.0 | PC Flanged Tube | 03146 | 25 | 6 | 23500 | 62976 | 29 x 102 | Closure | 03268 | 25 | PP Snap-on |
| | | | | | | | | | Adapter | 75003102 | 1 | 1 place/adapter |
| 50.0 | 46.0 | Nalgene FEP Oak Ridge Tube | 3114-0050 | 10 | 6 | 23500 | 62976 | 29 x 108 | Closure | Included | 10 | FEP Sealing |
| | | | | | | | | | Adapter | 75003102 | 1 | 1 place/adapter |
| 50.0 | 43.0 | Nalgene PC Oak Ridge Tube | 3138-0050 | 50 | 6 | 23500 | 62976 | 29 x 107 | Closure | Included | 50 | PP Sealing |
| | | | | | | | | | Adapter | 75003102 | 1 | 1 place/adapter |
| 50.0 | 43.0 | Nalgene PP Oak Ridge Tube | 3139-0050 | 50 | 6 | 23500 | 62976 | 29 x 107 | Closure | Included | 50 | PP Sealing |
| | | | | | | | | | Adapter | 75003102 | 1 | 1 place/adapter |
| 50.0 | 45.0 | Conical Tissue Culture Tube | - | - | 6 | 17000 | 32956 | 30 x 121 | Adapter | 75003103 | - | 1 place/adapter |
| | | | | | | | | | | | | |
| 50.0 | 43.0 | Round Bottom Tube | - | - | 6 | 23500 | 62976 | 30 x 117 | Adapter | 75003102 | - | 1 place/adapter |
| 38.0 | 35.0 | Round Bottom Tube | - | - | 6 | 23500 | 62976 | 26 x 110 | Adapter | 75003094 | - | 1 place/adapter |
| 30.0 | 28.0 | PC Oak Ridge Tube | 314348 | 25 | 6 | 23500 | 62976 | 25 x 94 | Closure | 314347 | 1 | Aluminum Sealing Assembly |
| | | | | | | | | | Adapter | 75003027 | 1 | 1 place/adapter |
| | | | | | | | | | Adapter | 75003102 | - | 1 place/adapter |
| | | | | | | | | | Tool | 314353 | 1 | Tube Extractor Tool |
| 30.0 | 28.0 | PP Oak Ridge Tube | 314349 | 25 | 8 | 23500 | 62976 | 25 x 94 | Closure | 314347 | 1 | Aluminum Sealing Assembly |

| Tube vol. (mL) | Vol. fill (mL) | Description | Cat. No. | Qty./pkg. | Tubes/rotor | Max. speed (rpm) | Max. RCF ² (x g) | Dims ØxL (mm) | Required tube closures, adapters, tools & accessories | | | |
|----------------|----------------|-----------------------------|-----------|-----------|-------------|------------------|-----------------------------|---------------|---|----------|-----------|---------------------|
| | | | | | | | | | Type | Cat. No. | Qty./pkg. | Description |
| | | | | | | | | | Adapter | 75003027 | 1 | 1 place/adapter |
| | | | | | | | | | Adapter | 75003102 | 1 | 1 place/adapter |
| | | | | | | | | | Tool | 314353 | 1 | Tube Extractor Tool |
| 30.0 | 28.0 | PP Tube | 75002951 | 10 | 6 | 23500 | 62976 | 18 x 100 | Closure | 75002957 | 10 | PP Stopper |
| | | | | | | | | | Adapter | 75003102 | 1 | 1 place/adapter |
| 16.0 | 16.0 | Nalgene PC Oak Ridge Tube | 3138-0016 | 50 | 6 | 23500 | 62976 | 18 x 123 | Adapter | 76002906 | - | 1 place/adapter |
| | | | | | | | | | | | | |
| 16.0 | 16.0 | Nalgene PP Oak Ridge Tube | 3139-0016 | 50 | 6 | 23500 | 62976 | 18 x 123 | Adapter | 76002906 | - | 1 place/adapter |
| | | | | | | | | | | | | |
| 15.0 | 15.0 | Conical Tissue Culture Tube | - | - | 6 | 17000 | 32956 | 17 x 123 | Adapter | 75003095 | - | 1 place/adapter |
| | | | | | | | | | | | | |
| 12.0 | 11.0 | PC Flanged Tube | 03115 | 50 | 6 | 23500 | 62976 | 16 x 100 | Closure | 03266 | 50 | PP Non-sealing |
| | | | | | | | | | Adapter | 00402 | 1 | 1 place/adapter |
| | | | | | | | | | Adapter | 75003102 | 1 | 1 place/adapter |
| 12.0 | 12.0 | Round Bottom Tube | - | - | 12 | 23500 | 62976 | 16 x 95 | Adapter | 75003093 | - | 2 places/adapter |
| 10.0 | 9.1 | PP Oak Ridge Tube | 03929 | 50 | 6 | 23500 | 62976 | 16 x 80 | Closure | 03279 | 25 | PP Sealing |
| | | | | | | | | | Adapter | 75003024 | 2 | 1 place/adapter |
| | | | | | | | | | Adapter | 75003102 | 1 | 1 place/adapter |
| 10.0 | 9.1 | PC Oak Ridge Tube | 03020 | 25 | 6 | 23500 | 62976 | 16 x 80 | Closure | 03279 | 25 | PP Sealing |
| | | | | | | | | | Adapter | 75003024 | 2 | 1 place/adapter |
| | | | | | | | | | Adapter | 75003102 | 1 | 1 place/adapter |
| 7.0 | 6.0 | PC Flanged Tube | 03120 | 50 | 6 | 23500 | 62976 | 13 x 100 | Closure | 03265 | 50 | PP Snap-on |
| | | | | | | | | | Adapter | 00473 | 1 | 1 place/adapter |
| | | | | | | | | | Adapter | 75003102 | 1 | 1 place/adapter |
| 6.5 | 6.5 | Round Bottom Tube | - | - | 12 | 23500 | 62976 | 13 x 114 | Adapter | 75003092 | - | 2 places/adapter |
| 4.0 | 3.0 | PC Flanged Tube | 03104 | 50 | 12 | 23500 | 62976 | 11 x 75 | Closure | 03264 | 50 | PP Snap-on |
| | | | | | | | | | Adapter | 75003023 | 2 | 2 places/adapter |
| | | | | | | | | | Adapter | 75003102 | 1 | 1 place/adapter |

| Tube vol. (mL) | Vol. fill (mL) | Description | Cat. No. | Qty./pkg. | Tubes/rotor | Max. speed (rpm) | Max. RCF ² (x g) | Dims ØxL (mm) | Required tube closures, adapters, tools & accessories | | | |
|----------------|----------------|-------------------|----------|-----------|-------------|------------------|-----------------------------|---------------|---|----------|-----------|------------------|
| | | | | | | | | | Type | Cat. No. | Qty./pkg. | Description |
| 3.5 | 3.5 | Round Bottom Tube | - | - | 24 | 23500 | 62976 | 11 x 100 | Adapter | 75003091 | - | 4 places/adapter |
| 1.5/2.0 | - | Conical Microtube | - | - | 24 | 23500 | 62976 | 11 x 40 | Adapter | 76002905 | - | 4 places/adapter |

Refer to manufacturer's recommendations for product performance information.

Table 48: A23-6x100 rotor labware

6. 7. 6. Biocontainment Certificate

Health Protection Agency
Microbiology Services
Porton Down
Salisbury
Wiltshire
SP4 0JG



Certificate of Containment Testing

Containment Testing of Rotor A23-6x100 in a Thermo Scientific Centrifuge

Report No. 170-12 H

Report Prepared For: Thermo Fisher Scientific
Issue Date: 10th October 2012

Test Summary

An A23-6x100 rotor was containment tested in a Thermo Scientific centrifuge at 23,000 rpm at partial vacuum, using Annex AA of IEC 1010-2-20:2006 (2nd Ed.). The sealed rotor was shown to contain all contents.

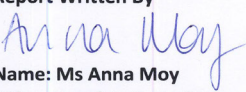
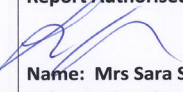
| | |
|--|---|
| <p>Report Written By  Name: Ms Anna Moy Title: Biosafety Scientist</p> | <p>Report Authorised By  Name: Mrs Sara Speight Title: Senior Biosafety Scientist</p> |
|--|---|

Thermo Scientific is a trademark of Thermo Fisher Scientific and is registered with the USPTO.

6.8. A27-6x50



6.8.1. Items Supplied

| Item | Cat. No. | Quantity |
|---|-----------|----------|
| A27-6x50 Rotor | 75003007 | 1 |
| 50 mL Nalgene PPCO Oak Ridge tube with sealing cap | 3139-0050 | 6 |
| O-Ring replacement kit (includes Grease for Bolts and Threads 76003500) | 75007006 | 1 |
| Retaining ring pliers | 65614 | 1 |
| Bolt Grease | 75003786 | 1 |
| Anti-corrosion Oil | 70009824 | 1 |

Table 49: Items supplied A27-6x50 rotor

6.8.2. Technical Data

| | |
|------------------------------|------------------|
| Type | Fixed angle |
| Material | Aluminum |
| Net Weight | 5.58 kg/12.3 lbs |
| Capacity | 6 x 50 mL |
| Maximum Permissible Load | 6 x 75 g |
| Tube Dimensions Ø x L | 29 x 108 mm |
| Maximum Number of Cycles | 50 000 |
| Radius (max. / min.) | 97 mm / 24 mm |
| Angle | 34° |
| Max. Autoclaving Temperature | 121 °C |
| Aerosol-tight | Yes |

Table 50: A27-6x50 rotor technical data

6.8.3. Rotor Performance Data

| Centrifuge | LYNX 4000 | LYNX 6000 |
|--|-------------|-------------|
| Maximum Speed | 24 000 rpm | 27 000 rpm |
| Maximum RCF-Value | 62 465 x g | 79 057 x g |
| K-Factor at n_{max} | 485 | 485 |
| Acceleration / Braking Time | 55 s / 75 s | 50 s / 80 s |
| Maximum Speed at 4 °C | 24 000 rpm | 25 500 rpm |
| Min. Sample Temperature at Max. Speed (Ambient Temperature 23 °C, Run Time 60 minutes) | 2 °C | 7 °C |

Table 51: A27-6x50 rotor performance data

6. 8. 4. Accessories

| Description | Cat. No. | Max. speed (rpm) | Max. RCF ² (x g) |
|---|----------|------------------|-----------------------------|
| Ultracrimp Sealing Tool and Crimp Gauge | 03920 | - | - |
| Ultracrimp Gauge Replacement | 03919 | - | - |
| Ultracrimp Extra Plugs and Caps | 03999 | - | - |
| Rotor Cap | 03538 | - | - |

Table 52: A27-6x50 rotor accessories

6. 8. 5. Labware

| Tube vol. (mL) | Vol. fill (mL) | Description | Cat. No. | Qty./pkg. | Tubes/rotor | Max. speed (rpm) | Max. RCF ² (x g) | Dims ØxL (mm) | Required tube closures, adapters, tools & accessories | | | |
|----------------|----------------|-----------------------------|-----------|-----------|-------------|------------------|-----------------------------|---------------|---|----------|-----------|-------------------------|
| | | | | | | | | | Type | Cat. No. | Qty./pkg. | Description |
| 50.0 | 50.0 | PA Ultracrimp Tube | 03528 | 25 | 6 | 27000 | 79057 | 29 x 108 | Closure | Included | 25 | Plugs and Aluminum Caps |
| | | | | | | | | | Accessory | 03538 | 1 | Rotor cap |
| | | | | | | | | | Accessory | 03529 | 1 | Tube Racks |
| | | | | | | | | | Accessory | 03920 | 1 | Sealing Tool |
| 50.0 | 43.0 | Nalgene PC Oak Ridge Tube | 3138-0050 | 50 | 6 | 27000 | 79057 | 29 x 108 | Closure | Included | 50 | PP Sealing |
| 50.0 | 43.0 | Nalgene PPCO Oak Ridge Tube | 3139-0050 | 50 | 6 | 27000 | 79057 | 29 x 107 | Closure | Included | 50 | PP Sealing |
| 50.0 | 46.0 | FEP Oak Ridge Tube | 3114-0050 | 10 | 6 | 21500 | 50129 | 29 x 108 | Closure | Included | 10 | FEP Screw Top |
| 50.0 | 37.0 | PP Flanged Tube | 03147 | 25 | 6 | 27000 | 79057 | 29 x 102 | Closure | 03268 | 25 | PP Snap-on |
| 50.0 | 36.0 | PC Flanged Tube | 03146 | 25 | 6 | 27000 | 79057 | 29 x 102 | Closure | 03268 | 25 | PP Snap-on |
| 50.0 | 46.0 | PA Flanged Tube | 03139 | 25 | 6 | 27000 | 79057 | 28 x 104 | - | - | - | - |
| 30.0 | 28.0 | PC Oak Ridge Tube | 314348 | 25 | 6 | 27000 | 79057 | 25 x 94 | Closure | 314347 | 1 | Aluminum Sealing |
| | | | | | | | | | Adapter | 75003027 | 2 | 1 place/adapter |
| | | | | | | | | | Tool | 314353 | 1 | Tube Extractor Tool |
| 30.0 | 28.0 | PP Oak Ridge Tube | 314349 | 25 | 6 | 27000 | 79057 | 25 x 94 | Closure | 314347 | 1 | Aluminum Sealing |
| | | | | | | | | | Adapter | 75003027 | 2 | 1 place/adapter |
| | | | | | | | | | Tool | 314353 | 1 | Tube Extractor Tool |
| 30.0 | - | Glass Tube | - | 6 | 6 | - | - | 24 x 106 | Adapter | 00368 | 1 | Optional Caps |
| 16.0 | 16.0 | Nalgene PC Oak Ridge Tube | 3138-0016 | 50 | - | 27000 | 79057 | 18 x 107 | Closure | Included | - | PA Sealing |
| | | | | | | | | | Adapter | 75003026 | 2 | 1 place/adapter |
| 16.0 | 16.0 | Nalgene PP Oak Ridge Tube | 3139-0016 | 50 | - | 27000 | 79057 | 18 x 107 | Closure | Included | - | PA Sealing |
| | | | | | | | | | Adapter | 75003026 | 2 | 1 place/adapter |

| Tube vol. (mL) | Vol. fill (mL) | Description | Cat. No. | Qty./pkg. | Tubes/rotor | Max. speed (rpm) | Max. RCF ² (x g) | Dims ØxL (mm) | Required tube closures, adapters, tools & accessories | | | |
|----------------|----------------|--------------------------------|-----------|-----------|-------------|------------------|-----------------------------|---------------|---|----------|-----------|------------------|
| | | | | | | | | | Type | Cat. No. | Qty./pkg. | Description |
| 16.0 | 13.0 | PP Flanged Tube | 03244 | 50 | 6 | 27000 | 79057 | 18 x 100 | Closure | 03299 | 50 | PP Snap-On |
| | | | | | | | | | Adapter | 75003026 | 2 | 1 place/adapter |
| 15.0 | - | Glass Tube | - | - | 6 | 11000 | 13122 | 18 x 102 | Adapter | 00363 | 1 | 1 place/adapter |
| 14.0 | 11.0 | PC Flanged Tube | 03246 | 50 | 6 | 27000 | 79057 | 18 x 75 | Closure | 03269 | 50 | PP Snap-on |
| | | | | | | | | | Adapter | 75003025 | 2 | 1 place/adapter |
| 12.0 | 10.0 | PP Flanged Tube | 03116 | 50 | 6 | 27000 | 79057 | 16 x 100 | Closure | 03266 | 50 | PP Nonsealing |
| | | | | | | | | | Adapter | 75003028 | 2 | 1 place/adapter |
| 12.0 | 11.0 | PC Flanged Tube | 03115 | 50 | 6 | 27000 | 79057 | 16 x 100 | Closure | 03266 | 50 | PP Nonsealing |
| | | | | | | | | | Adapter | 75003028 | 2 | 1 place/adapter |
| 10.0 | 10.0 | Nalgene PP Oak Ridge Tube | 3139-0010 | 50 | 6 | 27000 | 79057 | 16 x 83 | Closure | Included | - | PA Sealing |
| | | | | | | | | | Adapter | 75003024 | 2 | 1 place/adapter |
| 10.0 | 9.1 | PP Oak Ridge Tube ² | 03929 | 50 | 6 | 27000 | 79057 | 16 x 80 | Closure | 03279 | 25 | PP Sealing |
| | | | | | | | | | Adapter | 75003024 | 2 | 1 place/adapter |
| 10.0 | 9.1 | PC Oak Ridge Tube | 03020 | 25 | 6 | 27000 | 79057 | 16 x 80 | Closure | 03279 | 25 | PP Sealing |
| | | | | | | | | | Adapter | 75003024 | 2 | 1 place/adapter |
| 10.0 | 10.0 | Nalgene PC Oak Ridge Tube | 3138-0010 | 50 | 6 | 27000 | 79057 | 16 x 83 | Closure | Included | - | PA Sealing |
| | | | | | | | | | Adapter | 75003024 | 2 | 1 place/adapter |
| 7.0 | 6.0 | PC Flanged Tube | 03120 | 50 | 12 | 24000 | 62465 | 13 x 100 | Closure | 03265 | 50 | PP Snap-On |
| | | | | | | | | | Adapter | 00473 | 2 | 2 places/adapter |
| 7.0 | 6.0 | PP Flanged Tube | 03121 | 50 | 12 | 21000 | 47825 | 13 x 100 | Closure | 03265 | 50 | PP Snap-On |
| | | | | | | | | | Adapter | 00473 | 1 | 2 places/adapter |
| 4.0 | 3.0 | PP Flanged Tube | 03105 | 50 | 12 | 27000 | 79057 | 11 x 75 | Closure | 03264 | 50 | PP Snap-On |
| | | | | | | | | | Adapter | 75003023 | 2 | 2 places/adapter |
| 4.0 | 3.0 | PC Flanged Tube | 03104 | 50 | 12 | 27000 | 79057 | 11 x 75 | Closure | 03264 | 50 | PP Snap-On |
| | | | | | | | | | Adapter | 75003023 | 2 | 2 places/adapter |
| 1.5 | 1.5 | Polyallomer Microtube | 314352H01 | 100 | 18 | 20300 | 44826 | 11 x 40 | Adapter | 75003029 | 2 | 3 places/adapter |

² Rated to 21 000 rpm when partially filled.

Refer to manufacturer's recommendations for product performance information.

Table 53: A27-6x50 rotor labware

6. 8. 6. Biocontainment Certificate

Health Protection Agency
Microbiology Services
Porton Down
Salisbury
Wiltshire
SP4 0JG



Certificate of Containment Testing



Containment Testing of Rotor A27-6x50 in a Thermo Scientific Centrifuge

Report No. 170-12 D

Report Prepared For: Thermo Fisher Scientific
Issue Date: 10th October 2012

Test Summary

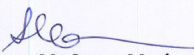
An A27-6x50 rotor was containment tested in a Thermo Scientific centrifuge at 27,000 rpm at partial vacuum, using Annex AA of IEC 1010-2-20:2006 (2nd Ed.). The sealed rotor was shown to contain all contents.

| | |
|--|---|
| Report Written By  Name: Ms Susan Macken Title: Biosafety Scientist | Report Authorised By  Name: Mrs Sara Speight Title: Senior Biosafety Scientist |
|--|---|

Thermo Scientific is a trademark of Thermo Fisher Scientific and is registered with the USPTO.

6.9. A27-8x50



6.9.1. Items Supplied

| Item | Cat. No. | Quantity |
|---|-----------|----------|
| A27-8x50 Rotor | 75003008 | 1 |
| 50 mL Nalgene PPCO Oak Ridge tube with sealing cap | 3139-0050 | 8 |
| Anti-corrosion Oil | 70009824 | 1 |
| Bolt Grease | 75003786 | 1 |
| O-Ring replacement kit (includes Grease for Bolts and Threads 76003500) | 75007009 | 1 |
| Retaining ring pliers | 65614 | 1 |

Table 54: Items supplied A27-8x50 rotor

6.9.2. Technical Data

| | |
|------------------------------|-----------------|
| Type | Fixed angle |
| Material | Aluminum |
| Net Weight | 6.8 kg/15.0 lbs |
| Capacity | 8 x 50 mL |
| Maximum Permissible Load | 8 x 75 g |
| Tube dimensions Ø x L | 29 x 108 mm |
| Maximum Number of Cycles | 50 000 |
| Radius (max. / min.) | 107 mm / 33 mm |
| Angle | 34° |
| Max. Autoclaving Temperature | 121 °C |
| Aerosol-tight | Yes |

Table 55: A27-8x50 rotor technical data

6.9.3. Rotor Performance Data

| Centrifuge | LYNX 4000 | LYNX 6000 |
|--|-------------|-------------|
| Maximum Speed | 24 000 rpm | 27 000 rpm |
| Maximum RCF-Value | 68 905 x g | 87 207 x g |
| K-Factor at n_{max} | 408 | 408 |
| Acceleration / Braking Time | 85 s / 95 s | 55 s / 85 s |
| Maximum Speed at 4 °C | 22 000 rpm | 23 500 rpm |
| Min. Sample Temperature at Max. Speed (Ambient Temperature 23 °C, Run Time 60 minutes) | 13 °C | 17 °C |

Table 56: A27-8x50 rotor performance data

6.9.4. Accessories

| Description | Cat. No. | Max. speed (rpm) | Max. RCF ² (x g) |
|---|----------|------------------|-----------------------------|
| Ultracrimp Sealing Tool and Crimp Gauge | 03920 | - | - |
| Ultracrimp Gauge RePlacement | 03919 | - | - |
| Ultracrimp Extra Plugs and Caps | 03999 | - | - |
| Rotor Cap | 03538 | - | - |

Table 57: A27-8x50 rotor accessories

6.9.5. Labware

| Tube vol. (mL) | Vol. fill (mL) | Description | Cat. No. | Qty./pkg. | Tubes/rotor | Max. speed (rpm) | Max. RCF ² (x g) | Dims ØxL (mm) | Required tube closures, adapters, tools & accessories | | | |
|----------------|----------------|-----------------------------------|-----------|-----------|-------------|------------------|-----------------------------|---------------|---|----------|-----------|-------------------------|
| | | | | | | | | | Type | Cat. No. | Qty./pkg. | Description |
| 50.0 | 50.0 | PA Ultracrimp Tube | 03528 | 25 | 8 | 27000 | 87207 | 29 x 108 | Closure | Included | 25 | Plugs and Aluminum Caps |
| | | | | | | | | | Accessory | 03538 | 1 | Rotor cap |
| | | | | | | | | | Accessory | 03529 | 2 | Tube Racks |
| | | | | | | | | | Accessory | 03920 | 1 | Crimp Sealing Tool |
| 50.0 | 37.0 | PP Flanged Tube | 03147 | 25 | 8 | 27000 | 87207 | 29 x 102 | Closure | 03268 | 25 | PP Snap-on |
| 50.0 | 36.0 | PC Flanged Tube | 03146 | 25 | 8 | 27000 | 87207 | 29 x 102 | Closure | 03268 | 25 | PP Snap-on |
| 50.0 | 46.0 | PA Thin-Walled Tube | 03139 | 25 | 8 | 21000 | 52755 | 28 x 104 | - | - | - | - |
| 50.0 | 46.0 | Nalgene FEP Oak Ridge Tube | 3114-0050 | 10 | 8 | 21000 | 52755 | 28 x 104 | Closure | Included | 10 | FEP Sealing |
| 50.0 | 43.0 | Nalgene PC Oak Ridge Style Tube | 3138-0050 | 50 | 8 | 27000 | 87207 | 29 x 107 | Closure | Included | 50 | PP Sealing |
| 50.0 | 43.0 | Nalgene PPCO Oak Ridge Style Tube | 3139-0050 | 50 | 8 | 27000 | 87207 | 29 x 107 | Closure | Included | 50 | PP Sealing |
| 30.0 | 28.0 | Nalgene PC Oak Ridge Tube | 3138-0030 | 50 | 8 | 27000 | 87207 | 26 x 102 | Closure | Included | 50 | PP Sealing |
| | | | | | | | | | | 75003027 | 2 | 1 place/adaptor |
| 30.0 | 28.0 | Nalgene PP Oak Ridge Tube | 3139-0030 | 50 | 8 | 27000 | 87207 | 26 x 102 | Closure | Included | 50 | PP Sealing |
| | | | | | | | | | | 75003027 | 2 | 1 place/adaptor |
| 30.0 | - | Glass Tube | - | - | 8 | - | - | 24 x 106 | Adapter | 00368 | 1 | Optional Caps |
| 16.0 | 16.0 | Nalgene PP Oak Ridge Tube | 3139-0016 | 50 | 8 | 27000 | 87207 | 18 x 107 | Closure | Included | - | PA Sealing |
| | | | | | | | | | Adapter | 75003026 | 2 | 1 place/adaptor |
| 16.0 | 13.0 | PP Flanged Tube | 03244 | 50 | 8 | 27000 | 87207 | 18 x 100 | Closure | 03299 | 50 | HDPE Sealing |
| | | | | | | | | | Adapter | 75003026 | 2 | 1 place/adaptor |
| 16.0 | 16.0 | Nalgene PC Oak Ridge Tube | 3138-0016 | 50 | 8 | 27000 | 87207 | 18 x 107 | Closure | Included | - | PA Sealing |
| | | | | | | | | | Adapter | 75003026 | 2 | 1 place/adaptor |

| Tube vol. (mL) | Vol. fill (mL) | Description | Cat. No. | Qty./pkg. | Tubes/rotor | Max. speed (rpm) | Max. RCF ² (x g) | Dims ØxL (mm) | Required tube closures, adapters, tools & accessories | | | |
|----------------|----------------|---------------------------|-----------|-----------|-------------|------------------|-----------------------------|---------------|---|----------|-----------|------------------|
| | | | | | | | | | Type | Cat. No. | Qty./pkg. | Description |
| 15.0 | 15.0 | Conical Tube | - | - | 8 | - | - | - | Adapter | 75007321 | 2 | 1 place/adapter |
| 14.0 | 11.0 | PC Flanged Tube | 03246 | 50 | 8 | 27000 | 87207 | 18 x 75 | Closure | 03269 | 50 | PP Snap-on |
| | | | | | | | | | Adapter | 75003025 | 2 | 1 place/adapter |
| 12.0 | 10.0 | PP Flanged Tube | 03116 | 50 | 8 | 27000 | 87207 | 16 x 100 | Closure | 03266 | 50 | PP Snap on |
| | | | | | | | | | Adapter | 00402 | 2 | 1 place/adapter |
| 12.0 | 11.0 | PC Flanged Tube | 03115 | 50 | 8 | 27000 | 87207 | 16 x 100 | Closure | 03266 | 50 | PP Snap on |
| | | | | | | | | | Adapter | 00402 | 2 | 1 place/adapter |
| 10.0 | 9.1 | PP Oak Ridge Tube | 03929 | 50 | 8 | 27000 | 87207 | 16 x 80 | Closure | 03279 | 25 | PP Snap on |
| | | | | | | | | | Adapter | 75003024 | 2 | 1 place/adapter |
| 10.0 | 10.0 | Nalgene PC Oak Ridge Tube | 3138-0010 | 50 | 8 | 27000 | 87207 | 16 x 83 | Closure | Included | - | PA Sealing |
| | | | | | | | | | Adapter | 75003024 | 2 | 1 place/adapter |
| 10.0 | 10.0 | Nalgene PP Oak Ridge Tube | 3139-0010 | 50 | 8 | 27000 | 87207 | 16 x 83 | Closure | Included | - | PA Sealing |
| | | | | | | | | | Adapter | 75003024 | 2 | 1 place/adapter |
| 10.0 | 9.1 | PC Oak Ridge Tube | 03020 | 25 | 8 | 27000 | 87207 | 16 x 80 | Closure | 03279 | 25 | PP Sealing |
| | | | | | | | | | Adapter | 75003024 | 2 | 1 place/adapter |
| 7.0 | 6.0 | PC Flanged Tube | 03120 | 50 | 8 | 21000 | 52755 | 13 x 100 | Closure | 03265 | 50 | PP Snap-On |
| | | | | | | | | | Adapter | 00473 | 1 | 1 place/adapter |
| 7.0 | 6.0 | PP Flanged Tube | 03121 | 50 | 8 | 21000 | 52755 | 13 x 100 | Closure | 03265 | 50 | PP Snap-On |
| | | | | | | | | | Adapter | 00473 | 1 | 1 place/adapter |
| 4.0 | 3.0 | PP Flanged Tube | 03105 | 50 | 8 | 27000 | 87207 | 11 x 75 | Closure | 03264 | 50 | PP Snap-On |
| | | | | | | | | | Adapter | 75003023 | 2 | 2 place/adapter |
| 4.0 | 3.0 | PC Flanged Tubes | 03104 | 50 | 16 | 27000 | 87207 | 11 x 75 | Closure | 03264 | 50 | PP Snap-On |
| | | | | | | | | | Adapter | 75003023 | 2 | 2 place/adapter |
| 1.5 | 1.5 | Polyallomer Microtube | 314352H01 | 100 | 24 | 21000 | 53302 | 11 x 40 | Adapter | 75003029 | 1 | 3 places/adapter |

Refer to manufacturer's recommendations for product performance information.

Table 58: A27-8x50 rotor labware

6. 9. 6. Biocontainment Certificate

Health Protection Agency
Microbiology Services
Porton Down
Salisbury
Wiltshire
SP4 0JG



Certificate of Containment Testing

Containment Testing of Rotor A27-8x50 in a Thermo Scientific Centrifuge

Report No. 170-12 C

Report Prepared For: Thermo Fisher Scientific

Issue Date: 10th October 2012

Test Summary

An A27-8x50 rotor was containment tested in a Thermo Scientific centrifuge at 27,000 rpm at partial vacuum, using Annex AA of IEC 1010-2-20:2006 (2nd Ed.). The sealed rotor was shown to contain all contents.

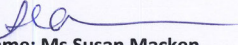
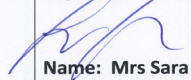
| | |
|--|---|
| Report Written By  Name: Ms Susan Macken Title: Biosafety Scientist | Report Authorised By  Name: Mrs Sara Speight Title: Senior Biosafety Scientist |
|--|---|

Thermo Scientific is a trademark of Thermo Fisher Scientific and is registered with the USPTO.

6.10. Fiberlite F9-6x1000 LEX



6. 10. 1. Items Supplied

| Item | Cat. No. | Quantity |
|-------------------------------|-------------|----------|
| Fiberlite F9-6x1000 LEX Rotor | 096-061075 | 1 |
| Rotor Care Kit | 020-0621075 | 1 |
| 1000ml Bottle Closure | 010-1471 | 6 |
| 1000ml Closure Liner | 010-1462 | 6 |
| 1000mL Closure O-Ring (4-PK) | 001-0298 | 6 |
| 1L PPCO Centrifuge Bottle w/o | 010-1407 | 6 |

Table 59: Items supplied F9-6x1000 LEX rotor

6. 10. 2. Technical Data

| | |
|------------------------------|------------------------|
| Type | Fixed angle |
| Material | Carbon Fiber Composite |
| Net Weight | 15.7 kg/34.5 lbs |
| Capacity | 6 x 1000 mL |
| Maximum Permissible Load | 6 x 1460 g |
| Tube Dimensions Ø x L | 98 x 195 mm |
| Radius (max. / min.) | 194 mm / 77 mm |
| Angle | 20° |
| Max. Autoclaving Temperature | 121 °C |

Table 60: F9-6x1000 LEX rotor technical data

6. 10. 3. Rotor Performance Data

| Centrifuge | LYNX 4000 | LYNX 6000 |
|--|-----------|---------------|
| Maximum Speed | - | 9000 rpm |
| Maximum RCF-Value (194 mm radius) | - | 17568 x g |
| Minimum RCF-Value (77 mm radius) | - | 6973 x g |
| K-Factor at n_{max} | - | 2886 |
| Acceleration / Braking Time | - | 135 s / 140 s |
| Maximum Speed at 4 °C | - | 9000 rpm |
| Min. Sample Temperature at Max. Speed (Ambient Temperature 23 °C, Run Time 60 minutes) | - | -10 °C |

Table 61: F9-6x1000 LEX rotor performance data

6.10.4. Labware

| Tube vol. (mL) | Vol. fill (mL) | Description | Cat. No. | Qty./pkg. | Tubes/rotor | Max. speed (rpm) | Max. RCF ² (x g) | Dims ØxL (mm) | Required tube closures, adapters, tools & accessories | | | |
|----------------|----------------|--|-----------|-----------|-------------|------------------|-----------------------------|---------------|---|-------------------|-----------|------------------------------------|
| | | | | | | | | | Type | Cat. No. | Qty./pkg. | Description |
| 1000.0 | 1000.0 | Thermo Scientific™ Fiberlite™ PPCO Bottle ⁴ | 010-1491 | 2 | 6 | 9000 | 17568 | 98 x 195 | Closure | Included | 2 | Nylon Cap w/ PP Plug |
| 1000.0 | 1000.0 | Thermo Scientific™ Fiberlite PC Bottle ⁴ | 010-1492 | 2 | 6 | 9000 | 17568 | 98 x 195 | Closure | Included | 2 | Nylon Cap w/ PP Plug |
| 1000.0 | 1000.0 | Thermo Scientific™ Sorvall™ PPCO High Perf. Bottle ^{2, 4} | 010-1456 | 2 | 6 | 9000 | 17568 | 98 x 195 | Closure | 75003511 Included | 2 | High Performance Al Cap w/ PP Plug |
| 1000.0 | 1000.0 | Sorvall PPCO High Perf. Bottle ^{3, 4} | 010-1459 | 2 | 6 | 9000 | 17568 | 98 x 195 | Closure | 75003511 Included | 2 | High Performance Al Cap w/ PP Plug |
| 500.0 | 400.0 | Fiberlite PPCO Bottle | 010-1493 | 6 | 6 | 9000 | 17568 | 70 x 160 | Closure | Included | 6 | PPGF Cap w/ PP Plug |
| | | | | | | | | | Adapter | 010-0145 | 2 | 1 place/adapter |
| 500.0 | 400.0 | Fiberlite PC Bottle | 010-1494 | 6 | 6 | 9000 | 17568 | 70 x 160 | Closure | Included | 6 | PPGF Cap w/ PP Plug |
| | | | | | | | | | Adapter | 010-0145 | 2 | 1 place/adapter |
| 500.0 | 450.0 | Thermo Scientific™ Nalgene™ PPCO Bottle | 3141-0500 | 24 | 6 | 7950 | 13700 | 70 x 160 | Closure | Included | 24 | PP Sealing |
| | | | | | | | | | Adapter | 010-0145 | 2 | 1 place/adapter |
| 500.0 | 450.0 | Thermo Scientific™ Nalgene™ PC Bottle | 3140-0500 | 24 | 6 | 7950 | 13700 | 70 x 160 | Closure | Included | 24 | PP Sealing |
| | | | | | | | | | Adapter | 010-0145 | 2 | 1 place/adapter |
| 250.0 | 250.0 | Fiberlite PPCO Bottle | 010-1495 | 6 | 6 | 9000 | 17568 | 61 x 124 | Closure | Included | 6 | PPGF Cap w/ PP Plug |
| | | | | | | | | | Adapter | 010-0150 | 2 | 1 place/adapter |
| 250.0 | 250.0 | Fiberlite PC Bottle | 010-1496 | 6 | 6 | 9000 | 17568 | 61 x 124 | Closure | Included | 6 | PPGF Cap w/ PP Plug |
| | | | | | | | | | Adapter | 010-0150 | 2 | 1 place/adapter |
| 250.0 | 250.0 | Nalgene PPCO Bottle | 3141-0250 | 36 | 6 | 9000 | 17568 | 61 x 133 | Closure | Included | 36 | PP Sealing |
| | | | | | | | | | Adapter | 010-0150 | 2 | 1 place/adapter |
| 250.0 | 250.0 | Nalgene PC Bottle | 3140-0250 | 36 | 6 | 9000 | 17568 | 61 x 135 | Closure | Included | 36 | PP Sealing |
| | | | | | | | | | Adapter | 010-0150 | 2 | 1 place/adapter |
| 250.0 | - | Corning™ Disposable Conical Tube | - | - | 6 | 9000 | 17568 | - | Adapter | 010-1096 | 2 | 1 place/adapter |

| Tube vol. (mL) | Vol. fill (mL) | Description | Cat. No. | Qty./pkg. | Tubes/rotor | Max. speed (rpm) | Max. RCF ² (x g) | Dims ØxL (mm) | Required tube closures, adapters, tools & accessories | | | |
|----------------|----------------|--|-----------|-----------|-------------|------------------|-----------------------------|---------------|---|----------|-----------|------------------|
| | | | | | | | | | Type | Cat. No. | Qty./pkg. | Description |
| 175.0 | 175.0 | Thermo Scientific™ Nalgene™ PPCO Conical Wide-Mouth Tube | 3143-0175 | 36 | 6 | 9000 | 17568 | 61 x 144 | Closure | Included | 36 | PP Sealing |
| | | | | | | | | | Adapter | 010-1132 | 2 | 1 place/adapter |
| 175.0 | 175.0 | Thermo Scientific™ Nalgene™ PC Conical Wide-Mouth Tube | 3144-0175 | 36 | 6 | 9000 | 17568 | 61 x 144 | Closure | Included | 36 | PP Sealing |
| | | | | | | | | | Adapter | 010-1132 | 2 | 1 place/adapter |
| 100 | 100 | Pyrex™ Tube | - | - | 12 | - | - | 43 x 139 | Adapter | 010-1425 | 2 | 2 places/adapter |
| 80.0 | 76.0 | PPCO Oak Ridge Tube | 010-1280 | 6 | 18 | 9000 | 17568 | 38 x 109 | Closure | Included | 6 | PP Sealing |
| | | | | | | | | | Adapter | 010-1093 | 2 | 3 places/adapter |
| 85.0 | 81.0 | Thermo Scientific™ Nalgene™ PC Oak Ridge Tube | 3118-0085 | 100 | 18 | 9000 | 17568 | 38 x 109 | Closure | Included | 100 | PP Screw Top |
| | | | | | | | | | Adapter | 010-1093 | 2 | 3 places/adapter |
| 50.0 | 50.0 | Thermo Scientific™ Nunc™ Disposable Conical Tube | 339653 | 25 | 18 | 9000 | 17568 | | Closure | Included | 25 | PP Sealing |
| | | | | | | | | | Adapter | 010-0180 | 2 | 5 places/adapter |
| 50.0 | - | Corning™ Disposable Conical Tube | - | - | 30 | - | - | - | Adapter | 010-0180 | 2 | 5 places/adapter |
| 50.0 | - | Falcon™ Disposable Conical Tube | - | - | 30 | - | - | - | Adapter | 010-0180 | 2 | 5 places/adapter |
| 50.0 | 46.0 | Nalgene PC Oak Ridge Tube | 3138-0050 | 50 | 30 | 9000 | 17568 | 29 x 115 | Closure | Included | 50 | PP Sealing |
| | | | | | | | | | Adapter | 010-1091 | 2 | 7 places/adapter |
| 50.0 | 46.0 | Nalgene PPCO Oak Ridge Tube | 3139-0050 | 50 | 36 | 9000 | 17568 | 29 x 115 | Closure | Included | 50 | PP Sealing |
| | | | | | | | | | Adapter | 010-1091 | 2 | 7 places/adapter |
| 50.0 | 46.0 | Nalgene PSF Oak Ridge Tube | 3137-0050 | 50 | 36 | 9000 | 17568 | 29 x 115 | Closure | Included | 50 | PP Sealing |
| | | | | | | | | | Adapter | 010-1091 | 2 | 7 places/adapter |
| 50.0 | 46.0 | Nalgene FEP Oak Ridge Tube | 3114-0050 | 10 | 36 | 9000 | 17568 | 29 x 108 | Closure | Included | 10 | ETFE Screw Cap |
| | | | | | | | | | Adapter | 010-1091 | 2 | 7 places/adapter |

| Tube vol. (mL) | Vol. fill (mL) | Description | Cat. No. | Qty./pkg. | Tubes/rotor | Max. speed (rpm) | Max. RCF ² (x g) | Dims ØxL (mm) | Required tube closures, adapters, tools & accessories | | | |
|----------------|----------------|---|-----------|-----------|-------------|------------------|-----------------------------|---------------|---|----------|-----------|-------------------|
| | | | | | | | | | Type | Cat. No. | Qty./pkg. | Description |
| 30.0 | 30.0 | Nalgene PC Oak Ridge Tube | 3138-0030 | 50 | 42 | 9000 | 17568 | 26 x 102 | Closure | Included | 50 | PP Sealing |
| | | | | | | | | | Adapter | 010-1095 | 2 | 7 places/adapter |
| 30.0 | 30.0 | Nalgene PPCO Oak Ridge Tube | 3139-0030 | 50 | 42 | 9000 | 17568 | 26 x 102 | Closure | Included | 50 | PP Sealing |
| | | | | | | | | | Adapter | 010-1095 | 2 | 7 places/adapter |
| 30.0 | 30.0 | Nalgene FEP Oak Ridge Tube | 3114-0030 | 10 | 42 | 9000 | 17568 | 26 x 102 | Closure | Included | 10 | ETFE Screw Cap |
| | | | | | | | | | Adapter | 010-1095 | 2 | 7 places/adapter |
| 16.0 | 16.0 | Nalgene PC Oak Ridge Tube | 3138-0016 | 50 | 84 | 9000 | 17568 | 18 x 107 | Closure | Included | 50 | PP Sealing |
| | | | | | | | | | Adapter | 010-1087 | 2 | 14 places/adapter |
| 16.0 | 16.0 | Nalgene PPCO Oak Ridge Tube | 3139-0016 | 50 | 84 | 9000 | 17568 | 18 x 107 | Closure | Included | 50 | PP Sealing |
| | | | | | | | | | Adapter | 010-1087 | 2 | 14 places/adapter |
| 15.0 | - | Corning™ Disposable Conical Tube | - | - | 72 | - | - | - | Adapter | 010-1079 | 2 | 12 places/adapter |
| 15.0 | - | Falcon™ Disposable Conical Tube | - | - | 72 | - | - | - | Adapter | 010-1079 | 2 | 12 places/adapter |
| 10.0 | 8.0 | Nalgene PPCO Oak Ridge Tube | 3139-0010 | 50 | 108 | 9000 | 17568 | 16 x 100 | Closure | Included | 50 | PP Sealing |
| | | | | | | | | | Adapter | 010-1307 | 2 | 18 places/adapter |
| 10.0 | 8.0 | Nalgene PC Oak Ridge Tube | 3138-0010 | 50 | 108 | 9000 | 17568 | 16 x 100 | Closure | Included | 50 | PP Sealing |
| | | | | | | | | | Adapter | 010-1307 | 2 | 18 places/adapter |
| 10.0 | - | BD Vacutainer™ Tube | - | - | 108 | - | - | 16 x 100 | Adapter | 010-1415 | 2 | 18 places/adapter |
| 6.0 | 6.0 | BD Vacutainer Tube | - | - | 132 | - | - | 13 x 100 | Adapter | 010-1416 | 2 | 22 places/adapter |
| 2.0 | 2.0 | Filtration Tube and 1.5 mL Conical Tube | - | - | 72 | - | - | 13 x 45 | Adapter | 010-1417 | 2 | 12 places/adapter |
| 1.8-2.7 | - | BD Vacutainer Tube | - | - | 180 | - | - | 16 x 100 | Adapter | 010-1419 | 2 | 30 places/adapter |

² Replacement PPCO bottle without closure, set of 2, 010-1455.

³ Replacement PC bottle without closure, set of 2, 010-1458.

⁴ Follow all chemical compatibility limitations.

Refer to manufacturer's recommendations for product performance information.



CAUTION

Only the labware listed is authorized by Thermo Fisher Scientific. Using labware products other than those listed can lead to personal harm, damage to rotor and centrifuge and sample loss.

Table 62: F9-6x1000 LEX rotor labware

6. 10. 5. Biocontainment Certificate

Health Protection Agency
Microbiology Services
Porton Down
Salisbury
Wiltshire
SP4 0JG



Certificate of Containment Testing

Containment Testing of Rotor F9-6x1000 LEX in a Thermo Scientific Centrifuge

Report No. 195-12 A

Report Prepared For: Thermo Fisher Scientific

Issue Date: 18th October 2012

Test Summary

A F9-6x1000 LEX rotor was containment tested in a Thermo Scientific centrifuge at 9,000 rpm at partial vacuum, using Annex AA of IEC 61010-2-020:2006 (2nd Ed.). The sealed rotor was shown to contain all contents.

| | |
|--|---|
| Report Written By  Name: Ms Anna Moy Title: Biosafety Scientist | Report Authorised By  Name: Mrs Sara Speight Title: Senior Biosafety Scientist |
|--|---|

Thermo Scientific is a trademark of Thermo Fisher Scientific and is registered with the USPTO.

6.11. Fiberlite F10-4x1000 LEX



6. 11. 1. Items Supplied

| Item | Cat. No. | Quantity |
|---------------------------------------|------------|----------|
| Fiberlite F10-4x1000 LEX Rotor | 096-041075 | 1 |
| Rotor Care Kit | 020-041075 | 1 |
| 1000ml Bottle Closure | 010-1471 | 4 |
| 1000ml Closure Liner | 010-1462 | 4 |
| 1000mL Closure O-Ring (4-PK) | 001-0298 | 4 |
| 1L PPCO Centrifuge Bottle w/o Closure | 010-1407 | 4 |

Table 63: Items supplied F10-4x1000 LEX rotor

6. 11. 2. Technical Data

| | |
|------------------------------|------------------------|
| Type | Fixed angle |
| Material | Carbon Fiber Composite |
| Net Weight | 10.9 kg/24 lbs |
| Capacity | 4 x 1000 mL |
| Maximum Permissible Load | 6 x 1460 g |
| Tube Dimensions Ø x L | 98 x 195 mm |
| Radius (max. / min.) | 167 mm / 500 mm |
| Angle | 20° |
| Max. Autoclaving Temperature | 121 °C |

Table 64: F10-4x1000 LEX rotor technical data

6. 11. 3. Rotor Performance Data

| Centrifuge | LYNX 4000 | LYNX 6000 |
|--|---------------|---------------|
| Maximum Speed | 10 500 rpm | 10 500 rpm |
| Maximum RCF-Value (167 mm radius) | 20 584 x g | 20 584 x g |
| Minimum RCF-Value (50 mm radius) | 6 163 x g | 6 163 x g |
| K-Factor at n_{max} | 2 767 | 2 767 |
| Acceleration / Braking Time | 100 s / 110 s | 100 s / 110 s |
| Maximum Speed at 4 °C | 10 500 rpm | 10 500 rpm |
| Min. Sample Temperature at Max. Speed (Ambient Temperature 23 °C, Run Time 60 minutes) | -6 °C | -6 °C |

Table 65: F10-4x1000 LEX rotor performance data

6.11.4. Labware

| Tube vol. (mL) | Vol. fill (mL) | Description | Cat. No. | Qty./pkg. | Tubes/rotor | Max. speed (rpm) | Max. RCF ² (x g) | Dims ØxL (mm) | Required tube closures, adapters, tools & accessories | | | |
|----------------|----------------|---|-----------|-----------|-------------|------------------|-----------------------------|---------------|---|-------------------|-----------|------------------------------------|
| | | | | | | | | | Type | Cat. No. | Qty./pkg. | Description |
| 1000.0 | 1000.0 | Fiberlite PPCO Bottle ⁴ | 010-1491 | 2 | 4 | 10500 | 20584 | 98 x 195 | Closure | Included | 2 | Nylon Cap w/ PP Plug |
| 1000.0 | 1000.0 | Fiberlite PC Bottle ⁴ | 010-1492 | 2 | 4 | 10500 | 20584 | 98 x 195 | Closure | Included | 2 | Nylon Cap w/ PP Plug |
| 1000.0 | 1000.0 | Sorvall PPCO High Perf. Bottle ⁴ | 010-1456 | 2 | 4 | 10500 | 20584 | 98 x 195 | Closure | 75003511 Included | 2 | High Performance Al Cap w/ PP Plug |
| 1000.0 | 1000.0 | Sorvall PC High Perf. Bottle ^{3,4} | 010-1459 | 2 | 4 | 10500 | 20584 | 98 x 195 | Closure | 75003511 Included | 2 | High Performance Al Cap w/ PP Plug |
| 500.0 | 400.0 | Fiberlite PPCO Bottle | 010-1493 | 6 | 6 | 10500 | 18859 | 70 x 160 | Closure | Included | 6 | PPGF Cap w/ PP Plug |
| | | | | | | | | | Adapter | | 2 | 1 place/adapter |
| 500.0 | 400.0 | Fiberlite PC Bottle | 010-1494 | 6 | 6 | 10500 | 18859 | 70 x 160 | Closure | Included | 6 | PPGF Cap w/ PP Plug |
| | | | | | | | | | Adapter | 010-0145 | 2 | 1 place/adapter |
| 500.0 | 450.0 | Nalgene PPCO Bottle | 3141-0500 | 24 | 4 | 8550 | 13700 | 70 x 160 | Al Cap Closure | Included | 24 | PP Sealing |
| | | | | | | | | | Adapter | 010-0145 | 2 | 1 place/adapter |
| 500.0 | 450.0 | Nalgene PC Bottle | 3140-0500 | 24 | 4 | 8550 | 13700 | 70 x 160 | Closure | Included | 24 | PP Sealing |
| | | | | | | | | | Adapter | 010-0145 | 2 | 1 place/adapter |
| 250.0 | 250.0 | Fiberlite PPCO Bottle | 010-1495 | 6 | 4 | 10500 | 18366 | 61 x 124 | Closure | Included | 6 | PPGF Cap w/ PP Plug |
| | | | | | | | | | Adapter | 010-0150 | 2 | 1 place/adapter |
| 250.0 | 250.0 | Fiberlite PC Bottle | 010-1496 | 6 | 4 | 10500 | 18366 | 61 x 124 | Closure | Included | 6 | PPGF Cap w/ PP Plug |
| | | | | | | | | | Adapter | 010-0150 | 2 | 1 place/adapter |
| 250.0 | 250.0 | Nalgene PPCO Bottle | 3141-0250 | 36 | 4 | 10500 | 18366 | 61 x 133 | Closure | Included | 36 | PP Sealing |
| | | | | | | | | | Adapter | 010-0150 | 2 | 1 place/adapter |
| 250.0 | 250.0 | Nalgene PC Bottle | 3140-0250 | 36 | 4 | 10500 | 18366 | 61 x 133 | Closure | Included | 36 | PP Sealing |
| | | | | | | | | | Adapter | 010-0150 | 2 | 1 place/adapter |
| 250.0 | 250.0 | Corning™ Disposable Conical Tube | - | - | 4 | 10500 | 18366 | - | Adapter | 010-1096 | 2 | 1 place/adapter |
| 175.0 | - | Nalgene PPCO Conical Wide-Mouth Bottle | 3143-0175 | 36 | 4 | 10500 | 15777 | 61 x 144 | Closure | Included | 36 | PP Sealing |
| | | | | | | | | | Adapter | 010-1132 | 2 | 1 place/adapter |
| 175.0 | - | Nalgene PC Conical Wide-Mouth Tube | 3144-0175 | 36 | 4 | 10500 | 15777 | 61 x 144 | Closure | Included | 36 | PP Sealing |

| Tube vol. (mL) | Vol. fill (mL) | Description | Cat. No. | Qty./pkg. | Tubes/rotor | Max. speed (rpm) | Max. RCF ² (x g) | Dims ØxL (mm) | Required tube closures, adapters, tools & accessories | | | |
|----------------|----------------|----------------------------------|-----------|-----------|-------------|------------------|-----------------------------|---------------|---|----------|-----------|-------------------|
| | | | | | | | | | Type | Cat. No. | Qty./pkg. | Description |
| | | | | | | | | | Adapter | 010-1132 | 2 | 1 place/adapter |
| 100 | 100 | Pyrex™ Tube | - | - | 20 | - | - | 43 x 139 | Adapter | 010-1425 | 2 | 2 places/adapter |
| 85.0 | 81.0 | Nalgene PC Oak Ridge Tube | 3118-0085 | 100 | 12 | 10500 | 19352 | 38 x 109 | Closure | Included | 100 | PP Sealing |
| | | | | | | | | | Adapter | 010-1093 | 2 | 3 places/adapter |
| 80.0 | 76.0 | PP Oak Ridge Tube | 010-1280 | 6 | 12 | 10500 | 19352 | 38 x 109 | Closure | Included | 6 | PP Sealing |
| | | | | | | | | | Adapter | 010-1093 | 2 | 3 places/adapter |
| 50.0 | - | Nunc Disposable Conical Tube | 339653 | 25 | 20 | - | - | 30 x 115 | Closure | Included | 25 | PP Sealing |
| | | | | | | | | | Adapter | 010-0180 | 2 | 5 places/adapter |
| 50.0 | - | Corning™ Disposable Conical Tube | - | - | 20 | - | - | - | Adapter | 010-0180 | 2 | 5 places/adapter |
| 50.0 | - | Falcon™ Disposable Conical Tube | - | - | 20 | - | - | - | Adapter | 010-0180 | 2 | 5 places/adapter |
| 50.0 | 46.0 | Nalgene PC Oak Ridge Tube | 3138-0050 | 50 | 28 | 10500 | 18119 | 29 x 108 | Closure | Included | 50 | PP Sealing |
| | | | | | | | | | Adapter | 010-1091 | 2 | 7 places/adapter |
| 50.0 | 46.0 | Nalgene PPCO Oak Ridge Tube | 3139-0050 | 50 | 28 | 10500 | 18119 | 29 x 108 | Closure | Included | 50 | PP Sealing |
| | | | | | | | | | Adapter | 010-1091 | 2 | 7 places/adapter |
| 50.0 | 46.0 | Nalgene PSF Oak Ridge Tube | 3137-0050 | 50 | 28 | 10500 | 18119 | 29 x 108 | Closure | Included | 50 | PP Sealing |
| | | | | | | | | | Adapter | 010-1091 | 2 | 7 places/adapter |
| 50.0 | 46.0 | Nalgene FEP Oak Ridge Tube | 3114-0050 | 10 | 28 | 10500 | 18119 | 29 x 108 | Closure | Included | 10 | ETFE Screw Cap |
| | | | | | | | | | Adapter | 010-1091 | 2 | 7 places/adapter |
| 30.0 | 30.0 | Nalgene PC Oak Ridge Tube | 3138-0030 | 50 | 28 | 10500 | 18119 | 26 x 102 | Closure | Included | 50 | PP Sealing |
| | | | | | | | | | Adapter | 010-1095 | 2 | 7 places/adapter |
| 30.0 | 30.0 | Nalgene PPCO Oak Ridge Tube | 3139-0030 | 50 | 28 | 10500 | 18119 | 26 x 102 | Closure | Included | 50 | PP Sealing |
| | | | | | | | | | Adapter | 010-1095 | 2 | 7 places/adapter |
| 30.0 | 30.0 | Nalgene FEP Oak Ridge Tube | 3114-0030 | 10 | 28 | 10500 | 18119 | 26 x 102 | Closure | Included | 10 | ETFE Screw Cap |
| | | | | | | | | | Adapter | 010-1095 | 2 | 7 places/adapter |
| 16.0 | 16.0 | Nalgene PC Oak Ridge Tube | 3138-0016 | 50 | 60 | 10500 | 18119 | 18 x 107 | Closure | Included | 50 | PP Sealing |
| | | | | | | | | | Adapter | 010-1087 | 2 | 15 places/adapter |

| Tube vol. (mL) | Vol. fill (mL) | Description | Cat. No. | Qty./pkg. | Tubes/rotor | Max. speed (rpm) | Max. RCF ² (x g) | Dims ØxL (mm) | Required tube closures, adapters, tools & accessories | | | |
|--|----------------|---|-----------|-----------|-------------|------------------|-----------------------------|---------------|---|----------|-----------|-------------------|
| | | | | | | | | | Type | Cat. No. | Qty./pkg. | Description |
| 16.0 | 16.0 | Nalgene PPCO Oak Ridge Tube | 3139-0016 | 50 | 60 | 10500 | 18119 | 18 x 107 | Closure | Included | 50 | PP Sealing |
| | | | | | | | | | Adapter | 010-1087 | 2 | 15 places/adapter |
| 15.0 | - | Corning™ Disposable Conical Tube | - | - | 48 | - | - | - | Adapter | 010-1079 | 2 | 12 places/adapter |
| 15.0 | - | Falcon™ Disposable Conical Tube | - | - | 48 | - | - | - | Adapter | 010-1079 | 2 | 12 places/adapter |
| 10.0 | 8.0 | Nalgene PPCO Oak Ridge Tube | 3139-0010 | 50 | 72 | 10500 | 20584 | 16 x 100 | Closure | Included | 50 | PP Sealing |
| | | | | | | | | | Adapter | 010-1307 | 2 | 18 places/adapter |
| 10.0 | 8.0 | Nalgene PC Oak Ridge Tube | 3138-0010 | 50 | 72 | 10500 | 20584 | 16 x 100 | Closure | Included | 50 | PP Sealing |
| | | | | | | | | | Adapter | 010-1307 | 2 | 18 places/adapter |
| 10.0 | - | BD Vacutainer™ Tube | - | - | 72 | - | - | 16 x 100 | Adapter | 010-1415 | 2 | 18 places/adapter |
| 6.0 | 6.0 | BD Vacutainer Tube | - | - | 88 | - | - | 13 x 100 | Adapter | 010-1416 | 2 | 22 places/adapter |
| 2.0 | 2.0 | Filtration Tube and 1.5 mL Conical Tube | - | - | 48 | - | - | 13 x 45 | Adapter | 010-1417 | 2 | 12 places/adapter |
| 1.8-2.7 | - | BD Vacutainer Tube | - | - | 120 | - | - | 10 x 64 | Adapter | 010-1419 | 2 | 30 places/adapter |
| ³ Replacement PC bottle without closure, set of 2, 010-1458. ⁴ Follow all chemical compatibility limitations. Refer to manufacturer's recommendations for product performance information. | | | | | | | | | | | | |



CAUTION

Only the labware listed is authorized by Thermo Fisher Scientific. Using labware products other than those listed can lead to personal harm, damage to rotor and centrifuge and sample loss.

Table 66: F10-4x1000 LEX rotor labware

6. 11. 5. Biocontainment Certificate

Centre of Emergency Preparedness and Response
Health Protection Agency
Porton Down
Salisbury
Wiltshire SP4 0JG
United Kingdom



Certificate of Containment Testing

Containment Testing of Fiberlite F10-4x1000y LEX Rotor in the Thermo Fisher Scientific Centrifuge

Report No. 74-10A

Report prepared for: Thermo Fisher Scientific
Issue Date: 17th January 2011

Test Summary

A Piramoon Technologies Inc. Fiberlite F10-4x1000y LEX (max speed 10,500rpm) rotor was containment tested in the Thermo Fisher Scientific centrifuge at 10,500rpm, using the method described in Annex AA of EN 61010-2-020. The rotor was shown to contain a spill within the rotor.

Report Written By

Anna May

Report Authorised By

[Signature]

6.12. Fiberlite F12-6x500 LEX



6.12.1. Items Supplied

| Item | Cat. No. | Quantity |
|--|------------|----------|
| Fiberlite F12-6x500 LEX Rotor | 096-062375 | 1 |
| Rotor Care Kit | 020-062375 | 1 |
| 500ml Bottle Closure | 010-1473 | 6 |
| 500ml Closure Liner | 010-1474 | 6 |
| 500mL Closure O-Ring, (12-PK) | 001-0299 | 6 |
| 500mL PPCO Centrifuge Bottle w/o Closure | 010-1406 | 6 |

Table 67: Items supplied F12-6x500 LEX rotor

6.12.2. Technical Data

| | |
|------------------------------|------------------------|
| Type | Fixed angle |
| Material | Carbon Fiber Composite |
| Net Weight | 9.1 kg/20 lbs |
| Capacity | 6 x 500 mL |
| Maximum Permissible Load | 6 x 675 g |
| Tube Dimensions Ø x L | 70 x 160 mm |
| Radius (max. / min.) | 152 mm / 69 mm |
| Angle | 20° |
| Max. Autoclaving Temperature | 121 °C |

Table 68: F12-6x500 LEX rotor technical data

6.12.3. Rotor Performance Data

| Centrifuge | LYNX 4000 | LYNX 6000 |
|--|-------------|-------------|
| Maximum Speed | 12 000 rpm | 12 000 rpm |
| Maximum RCF-Value (152 mm radius) | 24 471 x g | 24 471 x g |
| Minimum RCF-Value (69 mm radius) | 11 108 x g | 11 108 x g |
| K-Factor at n_{max} | 1 388 | 1 388 |
| Acceleration / Braking Time | 85 s / 95 s | 85 s / 95 s |
| Maximum Speed at 4 °C | 12 000 rpm | 12 000 rpm |
| Min. Sample Temperature at Max. Speed (Ambient Temperature 23 °C, Run Time 60 minutes) | -7 °C | -3 °C |

Table 69: F12-6x500 LEX rotor performance data

6.12.4. Labware

| Tube vol. (mL) | Vol. fill (mL) | Description | Cat. No. | Qty./pkg. | Tubes/rotor | Max. speed (rpm) | Max. RCF ² (x g) | Dims ØxL (mm) | Required tube closures, adapters, tools & accessories | | | |
|----------------|----------------|--|-----------|-----------|-------------|------------------|-----------------------------|---------------|---|----------|-----------|---------------------|
| | | | | | | | | | Type | Cat. No. | Qty./pkg. | Description |
| 500.0 | 400.0 | Fiberlite PPCO Bottle | 010-1493 | 6 | 6 | 12000 | 24471 | 70 x 160 | Closure | Included | 6 | PPGF Cap w/ PP Plug |
| 500.0 | 400.0 | Fiberlite PC Bottle | 010-1494 | 6 | 6 | 12000 | 24471 | 70 x 160 | Closure | Included | 6 | PPGF Cap w/ PP Plug |
| 500.0 | 450.0 | Nalgene PPCO Bottle | 3141-0500 | 24 | 6 | 9000 | 13700 | 70 x 160 | Closure | Included | 24 | PP Sealing |
| 500.0 | 450.0 | Nalgene PC Bottle | 3140-0500 | 24 | 6 | 9000 | 13700 | 70 x 160 | Closure | Included | 24 | PP Sealing |
| 250.0 | 250.0 | Fiberlite PPCO Bottle | 010-1495 | 6 | 6 | 12000 | 22260 | 61 x 124 | Closure | Included | 6 | PPGF Cap w/ PP Plug |
| | | | | | | | | | Adapter | 010-0151 | 2 | 1 place/adapter |
| 250.0 | 250.0 | Fiberlite PC Bottle | 010-1496 | 6 | 6 | 12000 | 22260 | 61 x 124 | Closure | Included | 6 | PPGF Cap w/ PP Plug |
| | | | | | | | | | Adapter | 010-0151 | 2 | 1 place/adapter |
| 250.0 | 250.0 | Nalgene PPCO Bottle | 3141-0250 | 36 | 6 | 12000 | 22260 | 61 x 124 | Closure | Included | 36 | PP Sealing |
| | | | | | | | | | Adapter | 010-0151 | 2 | 1 place/adapter |
| 250.0 | 250.0 | Nalgene PC Bottle | 3140-0250 | 36 | 6 | 12000 | 22260 | 61 x 124 | Closure | Included | 36 | PP Sealing |
| | | | | | | | | | Adapter | 010-0151 | 2 | 1 place/adapter |
| 250.0 | - | Corning™ Disposable Conical Bottle | - | - | 6 | - | - | - | Adapter | 010-1135 | 2 | 1 place/adapter |
| 175.0 | - | Nalgene PPCO Conical Wide-Mouth Bottle | 3143-0175 | 36 | 6 | - | - | 61 x 144 | Closure | Included | 36 | PP Sealing |
| | | | | | | | | | Adapter | 010-0152 | 2 | 1 place/adapter |
| 175.0 | - | Nalgene PC Conical Wide-Mouth Bottle | 3144-0175 | 36 | 6 | - | - | 61 x 144 | Closure | Included | 36 | PP Sealing |
| | | | | | | | | | Adapter | 010-0152 | 2 | 1 place/adapter |
| 80.0 | 73.0 | PC Oak Ridge Tube | 010-0515 | 6 | 6 | 12000 | 19190 | 38 x 109 | Closure | Included | 6 | PP Sealing |
| | | | | | | | | | Adapter | 010-1114 | 2 | 1 place/adapter |
| 80.0 | 76.0 | PPCO Oak Ridge Tube | 010-1280 | 6 | 6 | 12000 | 19190 | 38 x 109 | Closure | Included | 25 | PP Screw Top |
| | | | | | | | | | Adapter | 010-1114 | 2 | 1 place/adapter |
| 50.0 | - | Nunc Disposable Conical Tube | 339653 | 25 | 6 | - | - | 30 x 115 | Closure | Included | 25 | PP Sealing |
| | | | | | | | | | Adapter | 010-1102 | 2 | 1 place/adapter |
| 50.0 | - | Corning™ Disposable Conical Tube | - | - | 6 | - | - | - | Adapter | 010-1102 | 2 | 1 place/adapter |

| Tube vol. (mL) | Vol. fill (mL) | Description | Cat. No. | Qty./pkg. | Tubes/rotor | Max. speed (rpm) | Max. RCF ² (x g) | Dims ØxL (mm) | Required tube closures, adapters, tools & accessories | | | |
|----------------|----------------|----------------------------------|-----------|-----------|-------------|------------------|-----------------------------|---------------|---|----------|-----------|------------------|
| | | | | | | | | | Type | Cat. No. | Qty./pkg. | Description |
| 50.0 | - | Falcon™ Disposable Conical Tube | - | - | 6 | - | - | - | Adapter | 010-1102 | 2 | 1 place/adapter |
| 50.0 | 46.0 | Nalgene PC Oak Ridge Tube | 3138-0050 | 50 | 12 | 12000 | 22580 | 29 x 108 | Closure | Included | 50 | PP Sealing |
| | | | | | | | | | Adapter | 010-1112 | 2 | 2 places/adapter |
| 50.0 | 46.0 | Nalgene PPCO Oak Ridge Tube | 3139-0050 | 50 | 12 | 12000 | 22580 | 29 x 108 | Closure | Included | 50 | PP Sealing |
| | | | | | | | | | Adapter | 010-1112 | 2 | 2 places/adapter |
| 50.0 | 46.0 | Nalgene PSF Oak Ridge Tube | 3137-0050 | 50 | 12 | 12000 | 22580 | 29 x 108 | Closure | Included | 50 | PP Sealing |
| | | | | | | | | | Adapter | 010-1112 | 2 | 2 places/adapter |
| 50.0 | 46.0 | Nalgene FEP Oak Ridge Tube | 3114-0050 | 10 | 12 | 12000 | 22580 | 29 x 108 | Closure | Included | 10 | ETFE Screw Cap |
| | | | | | | | | | Adapter | 010-1112 | 2 | 2 places/adapter |
| 30.0 | 30.0 | Nalgene PC Oak Ridge Tube | 3138-0030 | 50 | 18 | 12000 | 20640 | 26 x 102 | Closure | Included | 50 | PP Sealing |
| | | | | | | | | | Adapter | 010-1115 | 2 | 3 places/adapter |
| 30.0 | 30.0 | Nalgene PPCO Oak Ridge Tube | 3139-0030 | 50 | 18 | 12000 | 20640 | 26 x 102 | Closure | Included | 50 | PP Sealing |
| | | | | | | | | | Adapter | 010-1115 | 2 | 3 places/adapter |
| 30.0 | 30.0 | Nalgene FEP Oak Ridge Tube | 3114-0030 | 10 | 18 | 12000 | 20640 | 26 x 102 | Closure | Included | 10 | ETFE Screw Cap |
| | | | | | | | | | Adapter | 010-1115 | 2 | 3 places/adapter |
| 16.0 | 16.0 | Nalgene PC Oak Ridge Tube | 3138-0016 | 50 | 42 | 12000 | 20640 | 18 x 107 | Closure | Included | 50 | PP Sealing |
| | | | | | | | | | Adapter | 010-1105 | 2 | 7 places/adapter |
| 16.0 | 16.0 | Nalgene PPCO Oak Ridge Tube | 3139-0016 | 50 | 42 | 12000 | 20640 | 18 x 107 | Closure | Included | 50 | PP Sealing |
| | | | | | | | | | Adapter | 010-1105 | 2 | 7 places/adapter |
| 15.0 | 15.0 | Corning™ Disposable Conical Tube | - | - | 36 | - | - | - | Adapter | 010-1099 | 2 | 6 places/adapter |
| 15.0 | 15.0 | Falcon™ Disposable Conical Tube | - | - | 36 | - | - | - | Adapter | 010-1099 | 2 | 6 places/adapter |
| 10.0 | 8.0 | Nalgene PPCO Oak Ridge Tube | 3139-0010 | 50 | 42 | 12000 | 20640 | 16 x 100 | Closure | Included | 50 | PP Sealing |
| | | | | | | | | | Adapter | 010-1308 | 2 | 7 places/adapter |
| 10.0 | 8.0 | Nalgene PC Oak Ridge Tube | 3138-0010 | 50 | 42 | 12000 | 20640 | 16 x 100 | Closure | Included | 50 | PP Sealing |
| | | | | | | | | | Adapter | 010-1308 | 2 | 7 places/adapter |
| 10.0 | - | BD Vacutainer™ Tube | - | - | 42 | - | - | 16 x 100 | Adapter | 010-1103 | 2 | 7 places/adapter |

| Tube vol. (mL) | Vol. fill (mL) | Description | Cat. No. | Qty./pkg. | Tubes/rotor | Max. speed (rpm) | Max. RCF ² (x g) | Dims ØxL (mm) | Required tube closures, adapters, tools & accessories | | | |
|----------------|----------------|--------------------|----------|-----------|-------------|------------------|-----------------------------|---------------|---|----------|-----------|-------------------|
| | | | | | | | | | Type | Cat. No. | Qty./pkg. | Description |
| 3.0 | - | BD Vacutainer Tube | - | - | 84 | - | - | 10 x 64 | Adapter | 010-1137 | 2 | 14 places/adapter |

Refer to manufacturer's recommendations for product performance information.



| | | |
|---|----------------|--|
|  | CAUTION | Only the labware listed is authorized by Thermo Fisher Scientific. Using labware products other than those listed can lead to personal harm, damage to rotor and centrifuge and sample loss. |
|---|----------------|--|

Table 70: F12-6x500 LEX rotor labware

6. 12. 5. Biocontainment Certificate

Centre of Emergency Preparedness and Response
Health Protection Agency
Porton Down
Salisbury
Wiltshire SP4 0JG
United Kingdom



Certificate of Containment Testing

Containment Testing of Fiberlite F12-6x500y LEX Rotor in the Thermo Fisher Scientific Centrifuge

Report No. 74-10B

Report prepared for: Thermo Fisher Scientific
Issue Date: 17th January 2011

Test Summary

A Piramoon Technologies Inc. Fiberlite F12-6x500y LEX (max speed 12,000rpm) rotor was containment tested in the Thermo Fisher Scientific centrifuge at 12,000rpm, using the method described in Annex AA of EN 61010-2-020. The rotor was shown to contain a spill within the rotor.

Report Written By

Anna May

Report Authorised By

[Signature]

6.13. Fiberlite F14-6x250y



6. 13. 1. Items Supplied

| Item | Cat. No. | Quantity |
|--|------------|----------|
| Fiberlite F14-6x250y Rotor | 096-062075 | 1 |
| Rotor Care Kit | 020-062075 | 1 |
| 250ml Bottle Closure | 010-1475 | 6 |
| 250ml Closure Liner | 010-1476 | 6 |
| 250mL Closure O-Ring (12-PK) | 001-0303 | 6 |
| 250mL PPCO Centrifuge Bottle w/o Closure | 010-1405 | 6 |

Table 71: Items supplied F14-6x250y rotor

6. 13. 2. Technical Data

| | |
|------------------------------|------------------------|
| Type | Fixed angle |
| Material | Carbon Fiber Composite |
| Net Weight | 8.0 kg/17.5 lbs |
| Capacity | 6 x 250 mL |
| Maximum Permissible Load | 6 x 420 g |
| Tube Dimensions Ø x L | 62 x 135 mm |
| Radius (max. / min.) | 138 mm / 61 mm |
| Angle | 23° |
| Max. Autoclaving Temperature | 121 °C |

Table 72: F14-6x250y rotor technical data

6. 13. 3. Rotor Performance Data

| Centrifuge | LYNX 4000 | LYNX 6000 |
|--|-------------|--------------|
| Maximum Speed | 14 000 rpm | 14 000 rpm |
| Maximum RCF-Value | 30 240 x g | 30 240 x g |
| K-Factor at n_{max} | 1 699 | 1 699 |
| Acceleration / Braking Time | 90 s / 95 s | 90 s / 100 s |
| Maximum Speed at 4 °C | 14 000 rpm | 14 000 rpm |
| Min. Sample Temperature at Max. Speed (Ambient Temperature 23 °C, Run Time 60 minutes) | -2 °C | -2 °C |

Table 73: F14-6x250y rotor performance data

6.13.4. Labware

| Tube vol. (mL) | Vol. fill (mL) | Description | Cat. No. | Qty./pkg. | Tubes/rotor | Max. speed (rpm) | Max. RCF ² (x g) | Dims ØxL (mm) | Required tube closures, adapters, tools & accessories | | | |
|----------------|----------------|---------------------------------------|-----------|-----------|-------------|------------------|-----------------------------|---------------|---|----------|-----------|---------------------|
| | | | | | | | | | Type | Cat. No. | Qty./pkg. | Description |
| 250.0 | 250.0 | Fiberlite PPCO Bottle | 010-1495 | 6 | 6 | 14000 | 30240 | 61 x 124 | Closure | Included | 6 | PPGF Cap w/ PP Plug |
| 250.0 | 250.0 | Fiberlite PC Bottle | 010-1496 | 6 | 6 | 14000 | 30240 | 61 x 124 | Closure | Included | 6 | PPGF Cap w/ PP Plug |
| 250.0 | 250.0 | Nalgene PPCO Bottle | 3141-0250 | 36 | 6 | 13350 | 27500 | 61 x 124 | Closure | Included | 36 | PP Sealing |
| 250.0 | 250.0 | Nalgene PC Bottle | 3140-0250 | 36 | 6 | 13350 | 27500 | 61 x 124 | Closure | Included | 36 | PP Sealing |
| 85.0 | 81.0 | Nalgene PC Oak Ridge Tube | 3118-0085 | 100 | 6 | 14000 | 30240 | 38 x 106 | Closure | Included | 100 | PP Screw Top |
| | | | | | | | | | Adapter | 010-1119 | 2 | 1 place/adapter |
| 80.0 | 76.0 | PPCO Oak Ridge Tube | 010-1280 | 6 | 6 | 14000 | 30240 | 38 x 109 | Closure | Included | 6 | PP Sealing |
| | | | | | | | | | Adapter | 010-1119 | 2 | 1 place/adapter |
| 50.0 | 50.0 | Nunc Disposable Conical Tube | 339653 | 25 | 6 | 9000 | 12497 | 30 x 115 | Closure | Included | 25 | PP Sealing |
| | | | | | | | | | Adapter | 75100136 | 2 | 1 place/adapter |
| 50.0 | - | Corning™ Disposable Conical Tube | - | - | 6 | 9000 | 12497 | - | Adapter | 75100136 | 2 | 1 place/adapter |
| 50.0 | - | Falcon™ Disposable Conical Tube | - | - | 6 | 9000 | 12497 | - | Adapter | 75100136 | 2 | 1 place/adapter |
| 50.0 | 46.0 | Nalgene PC Oak Ridge Screw Top Tube | 3138-0050 | 50 | 6 | 14000 | 30240 | 29 x 108 | Closure | Included | 50 | PP Sealing |
| | | | | | | | | | Adapter | 010-0138 | 2 | 1 place/adapter |
| 50.0 | 46.0 | Nalgene PPCO Oak Ridge Tube | 3139-0050 | 50 | 6 | 14000 | 30240 | 29 x 108 | Closure | Included | 50 | PP Sealing |
| | | | | | | | | | Adapter | 010-0138 | 2 | 1 place/adapter |
| 50.0 | 46.0 | Nalgene PSF Oak Ridge Tube | 3137-0050 | 50 | 8 | 14000 | 30240 | 29 x 108 | Closure | Included | 50 | PP Sealing |
| | | | | | | | | | Adapter | 010-0138 | 2 | 1 place/adapter |
| 50.0 | 46.0 | Nalgene FEP Oak Ridge Screw Top Tube | 3114-0050 | 10 | 6 | 14000 | 30240 | 29 x 108 | Closure | Included | 10 | ETFE Screw Cap |
| | | | | | | | | | Adapter | 010-0138 | 2 | 1 place/adapter |
| 30.0 | 30.0 | Nalgene PC Oak Ridge Screw Top Tube | 3138-0030 | 50 | 12 | 14000 | 30240 | 26 x 102 | Closure | Included | 50 | PP Sealing |
| | | | | | | | | | Adapter | 010-1072 | 2 | 2 places/ adapter |
| 30.0 | 30.0 | Nalgene PPCO Oak Ridge Screw Top Tube | 3139-0030 | 50 | 12 | 14000 | 30240 | 26 x 102 | Closure | Included | 50 | PP Sealing |
| | | | | | | | | | Adapter | 010-1072 | 2 | 2 places/ adapter |

| Tube vol. (mL) | Vol. fill (mL) | Description | Cat. No. | Qty./pkg. | Tubes/rotor | Max. speed (rpm) | Max. RCF ² (x g) | Dims ØxL (mm) | Required tube closures, adapters, tools & accessories | | | |
|----------------|----------------|----------------------------------|-----------|-----------|-------------|------------------|-----------------------------|---------------|---|----------|-----------|------------------|
| | | | | | | | | | Type | Cat. No. | Qty./pkg. | Description |
| 30.0 | 30.0 | Nalgene FEP Oak Ridge Tube | 3114-0030 | 10 | 12 | 14000 | 30240 | 26 x 102 | Closure | Included | 10 | ETFE Screw Cap |
| | | | | | | | | | Adapter | 010-1072 | 2 | 2 places/adapter |
| 16.0 | 16.0 | Nalgene PC Oak Ridge Tube | 3138-0016 | 50 | 30 | 14000 | 30240 | 18 x 107 | Closure | Included | 50 | PP Sealing |
| | | | | | | | | | Adapter | 010-1074 | 2 | 5 places/adapter |
| 16.0 | 16.0 | Nalgene PPCO Oak Ridge Tube | 3139-0016 | 50 | 30 | 14000 | 30240 | 18 x 107 | Closure | Included | 50 | PP Sealing |
| | | | | | | | | | Adapter | 010-1074 | 2 | 5 places/adapter |
| 15.0 | - | Corning™ Disposable Conical Tube | - | - | 30 | - | - | - | Adapter | 75101073 | 2 | 5 places/adapter |
| 15.0 | 15.0 | Nunc Conical Tube | 339650 | 25 | 30 | - | - | - | Adapter | 75101073 | 2 | 5 places/adapter |
| 15.0 | - | Falcon™ Disposable Conical Tube | - | - | 30 | - | - | - | Adapter | 010-1410 | 2 | 5 places/adapter |
| 10.0 | 8.0 | Nalgene PPCO Oak Ridge Tube | 3139-0010 | 50 | 42 | 14000 | 30240 | 16 x 100 | Closure | Included | 50 | PP Sealing |
| | | | | | | | | | Adapter | 010-1309 | 2 | 7 places/adapter |
| 10.0 | 8.0 | Nalgene PC Oak Ridge Tube | 3138-0010 | 50 | 42 | 14000 | 30240 | 16 x 100 | Closure | Included | 50 | PP Sealing |
| | | | | | | | | | Adapter | 010-1309 | 2 | 7 places/adapter |
| 10.0 | - | BD Vacutainer™ Tube | - | - | 42 | - | - | 16 x 100 | Adapter | 010-1117 | 2 | 7 places/adapter |
| 3.0 | - | BD Vacutainer Tube | - | - | 60 | - | - | 10 x 64 | Adapter | 010-1138 | 2 | 7 places/adapter |

Refer to manufacturer's recommendations for product performance information.



CAUTION

Only the labware listed is authorized by Thermo Fisher Scientific. Using labware products other than those listed can lead to personal harm, damage to rotor and centrifuge and sample loss.

Table 74: F14-6x250y rotor labware

6. 13. 5. Biocontainment Certificate

Centre of Emergency Preparedness and Response
Health Protection Agency
Porton Down
Salisbury
Wiltshire SP4 0JG
United Kingdom



Certificate of Containment Testing

Containment Testing of Fiberlite F14-6X250y Rotor in the Thermo Sorvall RC6 plus Centrifuge

Report No. 46-09 B

Report prepared for: Thermo Fisher Scientific
Issue Date: 22nd July 2009

Test Summary

A Piramoon technologies Inc. Fiberlite F14-6X250y (max speed 14,000rpm) rotor was containment tested in the Thermo Sorvall RC6 Plus centrifuge at 14,000rpm, using the method described in Annex AA of EN 61010-2-020. The rotor was shown to contain a spill within the rotor.

Report Written By

A handwritten signature in blue ink, written over a horizontal line.

Report Authorised By

A handwritten signature in blue ink, written over a horizontal line.

6.14. Fiberlite F14-14x50cy



6. 14. 1. Items Supplied

| Item | Cat. No. | Quantity |
|-----------------------------|------------|----------|
| Fiberlite F14-14x50cy Rotor | 096-145075 | 1 |
| Rotor Care Kit | 020-145075 | 1 |

Table 75: Items supplied F14-14x50cy rotor

6. 14. 2. Technical Data

| | |
|------------------------------|------------------------|
| Type | Fixed angle |
| Material | Carbon Fiber Composite |
| Net Weight | 7.7 kg/17 lbs |
| Capacity | 14 x 50 mL |
| Maximum Permissible Load | 14 x 75 g |
| Tube Dimensions Ø x L | 29 x 115 mm |
| Radius (max. / min.) | 154 mm / 83 mm |
| Angle | 34° |
| Max. Autoclaving Temperature | 121 °C |

Table 76: F14-14x50cy rotor technical data

6. 14. 3. Rotor Performance Data

| Centrifuge | LYNX 4000 | LYNX 6000 |
|--|-------------|-------------|
| Maximum Speed | 13 000 rpm | 14 000 rpm |
| Maximum RCF-Value | 29 097 x g | 33 746 x g |
| K-Factor at n_{max} | 798 | 798 |
| Acceleration / Braking Time | 80 s / 90 s | 80 s / 90 s |
| Maximum Speed at 4 °C | 13 000 rpm | 14 000 rpm |
| Min. Sample Temperature at Max. Speed (Ambient Temperature 23 °C, Run Time 60 minutes) | -3 °C | 0 °C |

Table 77: F14-14x50cy rotor performance data

6. 14. 4. Labware

| Tube vol. (mL) | Vol. fill (mL) | Description | Cat. No. | Qty./pkg. | Tubes/rotor | Max. speed (rpm) | Max. RCF ² (x g) | Dims ØxL (mm) | Required tube closures, adapters, tools & accessories | | | |
|----------------|----------------|---|----------|-----------|-------------|------------------|-----------------------------|---------------|---|----------|-----------|-------------|
| | | | | | | | | | Type | Cat. No. | Qty./pkg. | Description |
| 50.0 | 45.0 | Corning™ Disposable Conical Tube ² | - | - | 14 | 14 000 | 33 746 | - | - | - | - | - |
| 50.0 | 45.0 | Falcon™ Disposable Conical Tube ² | - | - | 14 | 14 000 | 33 746 | - | - | - | - | - |
| 50.0 | 45.0 | Nunc Disposable Conical Tube ² | 339653 | 25 | 14 | 8 690 | 13 000 | 30 x 115 | Closure | Included | 25 | PP Sealing |

| Tube vol. (mL) | Vol. fill (mL) | Description | Cat. No. | Qty./pkg. | Tubes/rotor | Max. speed (rpm) | Max. RCF ² (x g) | Dims ØxL (mm) | Required tube closures, adapters, tools & accessories | | | |
|----------------|----------------|----------------------------------|-----------|-----------|-------------|------------------|-----------------------------|---------------|---|------------|-----------|-----------------|
| | | | | | | | | | Type | Cat. No. | Qty./pkg. | Description |
| 50.0 | - | Amicon™ Filtration Tube | - | - | 14 | 5000 | 4304 | - | - | - | - | - |
| 50.0 | 46.0 | Nalgene PC Oak Ridge Tube | 3138-0050 | 50 | 4 | 14000 | 33746 | 29 x 108 | Closure | Included | 50 | PP Sealing |
| | | | | | | | | | Adapter | 010-0377 | 2 | 1 place/adapter |
| 50.0 | 46.0 | Nalgene PPCO Oak Ridge Tube | 3139-0050 | 50 | 14 | 14000 | 33527 | 29 x 108 | Closure | Included | 50 | PP Sealing |
| | | | | | | | | | Adapter | 010-0377 | 2 | 1 place/adapter |
| 50.0 | 46.0 | Nalgene PSF Oak Ridge Tube | 3137-0050 | 50 | 14 | 14000 | 33527 | 29 x 108 | Closure | Included | 50 | PP Sealing |
| | | | | | | | | | Adapter | 010-0377 | 2 | 1 place/adapter |
| 50.0 | 46.0 | Nalgene FEP Oak Ridge Tube | 3114-0050 | 10 | 14 | 14000 | 33527 | 29 x 108 | Closure | Included | 10 | ETFE Screw Cap |
| | | | | | | | | | Adapter | 010-0377 | 2 | 1 place/adapter |
| 30.0 | 30.0 | Nalgene PC Oak Ridge Tube | 3138-0030 | 50 | 14 | 14000 | 33527 | 26 x 102 | Closure | Included | 50 | PP Sealing |
| | | | | | | | | | Adapter | 010-1147 | 2 | 1 place/adapter |
| 30.0 | 30.0 | Nalgene PPCO Oak Ridge Tube | 3139-0030 | 50 | 14 | 14000 | 33527 | 26 x 102 | Closure | Included | 50 | PP Sealing |
| | | | | | | | | | Adapter | 010-1147 | 2 | 1 place/adapter |
| 30.0 | 30.0 | Nalgene FEP Oak Ridge Tube | 3114-0030 | 50 | 14 | 14000 | 33527 | 26 x 102 | Closure | Included | 50 | ETFE Screw Cap |
| | | | | | | | | | Adapter | 010-1147 | 2 | 1 place/adapter |
| 16.0 | 16.0 | Nalgene PC Oak Ridge Tube | 3139-0016 | 50 | 14 | 14000 | 33527 | 18 x 107 | Closure | Included | 50 | PP Sealing |
| | | | | | | | | | Adapter | 010-0376 | 2 | 1 place/adapter |
| 16.0 | 16.0 | Nalgene PPCO Oak Ridge Tube | 3138-0016 | 50 | 14 | 14000 | 33527 | 18 x 107 | Closure | Included | 50 | PP Sealing |
| | | | | | | | | | Adapter | 010-0376 | 2 | 1 place/adapter |
| 15.0 | - | Corning™ Disposable Conical Tube | - | - | 14 | 14000 | 33527 | - | Adapter | 75100378 | 2 | 1 place/adapter |
| 15.0 | - | Falcon™ Disposable Conical Tube | - | - | 14 | - | - | - | Adapter | 75100378 | 2 | 1 place/adapter |
| 15.0 | - | Amicon Filtration Devices | - | - | 14 | 5400 | 4988 | - | Adapter | 010-1340 | 2 | 1 place/adapter |
| 15.0 | 15.0 | Nunc EZ Flip™ Conical Tube | 362694 | 50 | 14 | 9000 | 13855 | - | Adapter | 010-1340 | 2 | 1 place/adapter |
| 15.0 | 15.0 | Nunc Conical Disposable Tube | 339650 | 50 | 14 | 9000 | 13855 | 17 x 120 | Closure | Included | 25 | PP Sealing |
| | | | | | | | | | Adapter | 010-1340 | 2 | 1 place/adapter |
| 10.0 | 8.0 | Nalgene PPCO Oak Ridge Tube | 3139-0010 | 50 | 14 | 14000 | 33527 | 16 x 100 | Closure | Included | 10 | PP Sealing |
| | | | | | | | | | Adapter | 010-1311 2 | 2 | 1 place/adapter |

| Tube vol. (mL) | Vol. fill (mL) | Description | Cat. No. | Qty./pkg. | Tubes/rotor | Max. speed (rpm) | Max. RCF ² (x g) | Dims ØxL (mm) | Required tube closures, adapters, tools & accessories | | | |
|----------------|----------------|---------------------------|-----------|-----------|-------------|------------------|-----------------------------|---------------|---|----------|-----------|-----------------|
| | | | | | | | | | Type | Cat. No. | Qty./pkg. | Description |
| 10.0 | 8.0 | Nalgene PC Oak Ridge Tube | 3138-0010 | 50 | 14 | 14000 | 33527 | 16 x 100 | Closure | Included | 10 | PP Sealing |
| | | | | | | | | | Adapter | 010-1311 | 2 | 1 place/adapter |
| 10.0 | - | BD Vacutainer™ Tube | - | - | 14 | - | - | 16 x 100 | Adapter | 010-1124 | 2 | 1 place/adapter |
| 5.0 | - | 5ml Eppendorf Microtube | - | - | 14 | 12000 | 25000 | - | Adapter | 75005770 | 1 | 1 place/adapter |

² Listed Max Speeds for Conical Disposable tubes may be higher than OEM tube specifications and may result in crazing and other cosmetic damage to the tube. Do not use these tubes more than once.
Refer to manufacturer's recommendations for product performance information.

Table 78: F14-14x50cy rotor labware

6. 14. 5. Biocontainment Certificate

Health Protection Agency
Microbiology Services
Porton Down
Salisbury
Wiltshire
SP4 0JG



Certificate of Containment Testing

Containment Testing of Rotor F14-14x50cy in a Thermo Scientific Centrifuge

Report No. 195-12 B

Report Prepared For: Thermo Fisher Scientific

Issue Date: 10th October 2012

Test Summary

A F14-14x50cy rotor was containment tested in a Thermo Scientific centrifuge at 14,000 rpm at partial vacuum, using Annex AA of IEC 61010-2-020:2006 (2nd Ed.). The sealed rotor was shown to contain all contents.

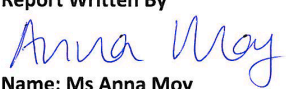
| | |
|--|---|
| Report Written By  Name: Ms Anna Moy Title: Biosafety Scientist | Report Authorised By  Name: Mrs Sara Speight Title: Senior Biosafety Scientist |
|--|---|

Thermo Scientific is a trademark of Thermo Fisher Scientific and is registered with the USPTO.

6.15. Fiberlite F20-12x50 LEX



6. 15. 1. Items Supplied

| Item | Cat. No. | Quantity |
|-------------------------------|------------|----------|
| Fiberlite F20-12x50 LEX Rotor | 096-124375 | 1 |
| Rotor Care Kit | 020-124375 | 1 |
| PPCO Nalgene 50mL Tubes | 010-1358 | 12 |

Table 79: Items supplied F20-12x50 LEX rotor

6. 15. 2. Technical Data

| | |
|------------------------------|------------------------|
| Type | Fixed angle |
| Material | Carbon Fiber Composite |
| Net Weight | 5.25 kg/11.5 lbs |
| Capacity | 12 x 50 mL |
| Maximum Permissible Load | 12 x 75 g |
| Tube Dimensions Ø x L | 29 x 115 mm |
| Radius (max. / min.) | 115 mm / 56 mm |
| Angle | 25° |
| Max. Autoclaving Temperature | 121 °C |

Table 80: F20-12x50 LEX rotor technical data

6. 15. 3. Rotor Performance Data

| Centrifuge | LYNX 4000 | LYNX 6000 |
|--|-------------|-------------|
| Maximum Speed | 18 000 rpm | 20 000 rpm |
| Maximum RCF-Value | 41 657 x g | 51 428 x g |
| K-Factor at n_{max} | 562 | 455 |
| Acceleration / Braking Time | 60 s / 80 s | 60 s / 80 s |
| Maximum Speed at 4 °C | 18 000 rpm | 20 000 rpm |
| Min. Sample Temperature at Max. Speed (Ambient Temperature 23 °C, Run Time 60 minutes) | 2 °C | 5 °C |

Table 81: F20-12x50 LEX rotor performance data

6. 15. 4. Labware

| Tube vol. (mL) | Vol. fill (mL) | Description | Cat. No. | Qty./pkg. | Tubes/rotor | Max. speed (rpm) | Max. RCF ² (x g) | Dims ØxL (mm) | Required tube closures, adapters, tools & accessories | | | |
|----------------|----------------|-----------------------------|-----------|-----------|-------------|------------------|-----------------------------|---------------|---|----------|-----------|----------------|
| | | | | | | | | | Type | Cat. No. | Qty./pkg. | Description |
| 50.0 | 46.0 | Nalgene PC Oak Ridge Tube | 3138-0050 | 50 | 12 | 20 000 | 51 428 | 29 x 115 | Closure | Included | 50 | PP Sealing |
| 50.0 | 46.0 | Nalgene PPCO Oak Ridge Tube | 3139-0050 | 50 | 12 | 20 000 | 51 428 | 29 x 115 | Closure | Included | 50 | PP Sealing |
| 50.0 | 46.0 | Nalgene PSF Oak Ridge Tube | 3137-0050 | 50 | 12 | 20 000 | 51 428 | 29 x 115 | Closure | Included | 50 | PP Sealing |
| 50.0 | 46.0 | Nalgene FEP Oak Ridge Tube | 3114-0050 | 10 | 12 | 20 000 | 51 428 | 29 x 108 | Closure | Included | 10 | ETFE Screw Cap |

| Tube vol. (mL) | Vol. fill (mL) | Description | Cat. No. | Qty./pkg. | Tubes/rotor | Max. speed (rpm) | Max. RCF ² (x g) | Dims ØxL (mm) | Required tube closures, adapters, tools & accessories | | | |
|----------------|----------------|---|-----------|-----------|-------------|------------------|-----------------------------|---------------|---|----------|-----------|-------------------|
| | | | | | | | | | Type | Cat. No. | Qty./pkg. | Description |
| 30.0 | 30.0 | Nalgene PC Oak Ridge Tube | 3138-0030 | 50 | 12 | 20000 | 51 428 | 29 x 108 | Closure | Included | 50 | PP Sealing |
| | | | | | | | | | Adapter | 010-0167 | 2 | 1 place/adapter |
| 30.0 | 30.0 | Nalgene PPCO Oak Ridge Tube | 3139-0030 | 50 | 12 | 20000 | 51 428 | 26 x 102 | Closure | Included | 50 | PP Sealing |
| | | | | | | | | | Adapter | 010-0167 | 2 | 1 place/adapter |
| 30.0 | 30.0 | Nalgene FEP Oak Ridge Tube | 3114-0030 | 10 | 12 | 20000 | 51 428 | 26 x 102 | Closure | Included | 10 | ETFE Screw Cap |
| | | | | | | | | | Adapter | 010-0167 | 2 | 1 place/adapter |
| 16.0 | 16.0 | Nalgene PC Oak Ridge Tube | 3138-0016 | 50 | 12 | 20000 | 51 428 | 18 x 107 | Closure | Included | 50 | PP Sealing |
| | | | | | | | | | Adapter | 010-0382 | 2 | 1 place/adapter |
| 16.0 | 16.0 | Nalgene PPCO Oak Ridge Tube | 3139-0016 | 50 | 12 | 20000 | 51 428 | 18 x 107 | Closure | Included | 50 | PP Sealing |
| | | | | | | | | | Adapter | 010-0382 | 2 | 1 place/adapter |
| 15.0 | - | Corning™ Disposable Conical Tube ³ | - | - | 12 | - | - | - | Closure | Included | - | PP Sealing |
| | | | | | | | | | Adapter | 010-1123 | 2 | 1 place/adapter |
| 15.0 | - | Falcon™ Disposable Conical Tube ³ | - | - | 12 | - | - | - | Adapter | 010-1123 | 2 | 1 place/adapter |
| | | | | | | | | | | | | |
| 14.0 | 11.0 | PC Flanged Tube | 03246 | 50 | 12 | 20000 | 51 428 | 18 x 75 | Closure | 03269 | 50 | PP Snap-on |
| | | | | | | | | | Adapter | 75003025 | 2 | 1 place/adapter |
| 10.0 | 8.0 | Nalgene PPCO Oak Ridge Tube | 3139-0010 | 50 | 12 | 20000 | 51 428 | 16 x 82 | Closure | Included | 50 | PP Sealing |
| | | | | | | | | | Adapter | 010-1306 | 2 | 1 place/adapter |
| 10.0 | 8.0 | Nalgene PC Oak Ridge Tube | 3138-0010 | 50 | 12 | 20000 | 51 428 | 16 x 82 | Closure | Included | 50 | PP Sealing |
| | | | | | | | | | Adapter | 010-1306 | 2 | 1 place/adapter |
| 10.0 | - | BD Vacutainer™ Tube | - | - | 12 | - | - | 16 x 100 | Adapter | 010-1068 | 2 | 1 place/adapter |
| 4.0 | 3.0 | PP Flanged Tube | 03105 | 50 | 24 | 19200 | 47 850 | 11 x 75 | Closure | 03264 | 50 | PP Snap-On |
| | | | | | | | | | Adapter | 75003023 | 2 | 2 places/ adapter |
| 4.0 | 3.0 | PC Flanged Tube | 03104 | 50 | 24 | 19200 | 47 850 | 11 x 75 | Closure | 03264 | 50 | PP Snap-On |
| | | | | | | | | | Adapter | 75003023 | 2 | 2 places/ adapter |
| 3.0 | - | BD Vacutainer Tube | - | - | 12 | - | - | 10 x 64 | Adapter | 010-1128 | 2 | 1 place/adapter |
| 1.5 | 1.5 | Polyallomer Microtube | 314352H01 | 100 | 36 | 16600 | 35 776 | 11 x 40 | Adapter | 75003029 | 2 | 3 places/ adapter |

| Tube vol. (mL) | Vol. fill (mL) | Description | Cat. No. | Qty./pkg. | Tubes/rotor | Max. speed (rpm) | Max. RCF ² (x g) | Dims ØxL (mm) | Required tube closures, adapters, tools & accessories | | | |
|----------------|----------------|----------------------|----------|-----------|-------------|------------------|-----------------------------|---------------|---|----------|-----------|------------------|
| | | | | | | | | | Type | Cat. No. | Qty./pkg. | Description |
| 1.0 | 1.0 | BD Microtainer™ Tube | - | - | 36 | - | - | 8 x 48 | Adapter | 010-1127 | 2 | 3 places/adapter |

Refer to manufacturer's recommendations for product performance information.

Table 82: F20-12x50 LEX rotor labware

6. 15. 5. Biocontainment Certificate

Health Protection Agency
Microbiology Services
Porton Down
Salisbury
Wiltshire
SP4 0JG



Certificate of Containment Testing

Containment Testing of Rotor F20-12x50 LEX in a Thermo Scientific Centrifuge

Report No. 195-12 D

Report Prepared For: Thermo Fisher Scientific
Issue Date: 10th October 2012

Test Summary

A F20-12x50 LEX rotor was containment tested in a Thermo Scientific centrifuge at 20,000 rpm at partial vacuum, using Annex AA of IEC 61010-2-020:2006 (2nd Ed.). The sealed rotor was shown to contain all contents.

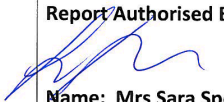
| | |
|--|---|
| Report Written By  Name: Ms Anna Moy Title: Biosafety Scientist | Report Authorised By  Name: Mrs Sara Speight Title: Senior Biosafety Scientist |
|--|---|

Thermo Scientific is a trademark of Thermo Fisher Scientific and is registered with the USPTO.

6.16. Fiberlite F21-8x50y



6. 16. 1. Items Supplied

| Item | Cat. No. | Quantity |
|---------------------------|------------|----------|
| Fiberlite F21-8x50y Rotor | 096-084275 | 1 |
| Rotor Care Kit | 020-084275 | 1 |
| PPCO Nalgene 50mL Tubes | 010-1358 | 8 |

Table 83: Items supplied F21-8x50y rotor

6. 16. 2. Technical Data

| | |
|------------------------------|------------------------|
| Type | Fixed angle |
| Material | Carbon Fiber Composite |
| Net Weight | 4.8 kg/10.5 lbs |
| Capacity | 8 x 50 mL |
| Maximum Permissible Load | 8 x 75 g |
| Tube Dimensions Ø x L | 29 x 115 mm |
| Radius (max. / min.) | 107 mm / 33 mm |
| Angle | 34° |
| Max. Autoclaving Temperature | 121 °C |

Table 84: F21-8x50y rotor technical data

6. 16. 3. Rotor Performance Data

| Centrifuge | LYNX 4000 | LYNX 6000 |
|--|-------------|-------------|
| Maximum Speed | 18 000 rpm | 20 000 rpm |
| Maximum RCF-Value | 38 759 x g | 47 850 x g |
| K-Factor at n_{max} | 919 | 744 |
| Acceleration / Braking Time | 40 s / 65 s | 40 s / 65 s |
| Maximum Speed at 4 °C | 18 000 rpm | 20 000 rpm |
| Min. Sample Temperature at Max. Speed (Ambient Temperature 23 °C, Run Time 60 minutes) | -7 °C | -2 °C |

Table 85: F21-8x50y rotor performance data

6.16.4. Labware

| Tube vol. (mL) | Vol. fill (mL) | Description | Cat. No. | Qty./pkg. | Tubes/rotor | Max. speed (rpm) | Max. RCF ² (x g) | Dims ØxL (mm) | Required tube closures, adapters, tools & accessories | | | |
|----------------|----------------|---|-----------|-----------|-------------|------------------|-----------------------------|---------------|---|----------|-----------|-------------------|
| | | | | | | | | | Type | Cat. No. | Qty./pkg. | Description |
| 50.0 | 46.0 | Nalgene PC Oak Ridge Tube | 3138-0050 | 50 | 8 | 20000 | 47850 | 29 x 115 | Closure | Included | 50 | PP Sealing |
| 50.0 | 46.0 | Nalgene PPCO Oak Ridge Tube | 3139-0050 | 50 | 8 | 20000 | 47850 | 29 x 115 | Closure | Included | 50 | PP Sealing |
| 50.0 | 46.0 | Nalgene PSF Oak Ridge Tube | 3137-0050 | 50 | 8 | 20000 | 47850 | 29 x 115 | Closure | Included | 50 | PP Sealing |
| 50.0 | 46.0 | Nalgene FEP Oak Ridge Tube | 3114-0050 | 10 | 8 | 20000 | 47850 | 29 x 108 | Closure | Included | 10 | ETFE Screw Cap |
| 30.0 | 30.0 | Nalgene PC Oak Ridge Tube | 3138-0030 | 50 | 8 | 20000 | 47850 | 26 x 102 | Closure | Included | 50 | PP Sealing |
| | | | | | | | | | Adapter | 010-0167 | 2 | 1 place/adapter |
| 30.0 | 30.0 | Nalgene PPCO Oak Ridge Tube | 3139-0030 | 50 | 8 | 20000 | 47850 | 26 x 102 | Closure | Included | 50 | PP Sealing |
| | | | | | | | | | Adapter | 010-0167 | 2 | 1 place/adapter |
| 30.0 | 30.0 | Nalgene FEP Oak Ridge Tube | 3114-0030 | 10 | 8 | 20000 | 47850 | 26 x 102 | Closure | Included | 10 | ETFE Screw Cap |
| | | | | | | | | | Adapter | 010-0167 | 2 | 1 place/adapter |
| 16.0 | 16.0 | Nalgene PC Oak Ridge Tube | 3138-0016 | 50 | 8 | 20000 | 47850 | 18 x 107 | Closure | Included | 50 | PP Sealing |
| | | | | | | | | | Adapter | 010-0382 | 2 | 1 place/adapter |
| 16.0 | 16.0 | Nalgene PPCO Oak Ridge Tube | 3139-0016 | 50 | 8 | 20000 | 47850 | 18 x 107 | Closure | Included | 50 | PP Sealing |
| | | | | | | | | | Adapter | 010-0382 | 2 | 1 place/adapter |
| 15.0 | - | Corning™ Disposable Conical Tube ³ | - | - | 8 | - | - | - | Adapter | 010-1123 | 2 | 1 place/adapter |
| 15.0 | - | Falcon™ Disposable Conical Tube ³ | - | - | 8 | - | - | - | Adapter | 010-1123 | 2 | 1 place/adapter |
| 14.0 | 11.0 | PC Flanged Tube | 03246 | 50 | 8 | 20000 | 47850 | 18 x 75 | Closure | 03269 | 50 | PP Snap-on |
| | | | | | | | | | Adapter | 75003025 | 2 | 1 place/adapter |
| 10.0 | 8.0 | Nalgene PPCO Oak Ridge Tube | 3139-0010 | 50 | 8 | 20000 | 47850 | 16 x 82 | Closure | Included | 50 | PP Sealing |
| | | | | | | | | | Adapter | 010-1306 | 2 | 1 place/adapter |
| 10.0 | 8.0 | Nalgene PC Oak Ridge Tube | 3138-0010 | 50 | 8 | 20000 | 47850 | 16 x 82 | Closure | Included | 50 | PP Sealing |
| | | | | | | | | | Adapter | 010-1306 | 2 | 1 place/adapter |
| 10.0 | - | BD Vacutainer™ Tube | - | - | 8 | - | - | 16 x 100 | Adapter | 010-1068 | 2 | 1 place/adapter |
| 4.0 | 3.0 | PP Flanged Tube | 03105 | 50 | 16 | 20000 | 47850 | 11 x 75 | Closure | 03264 | 50 | PP Snap-On |
| | | | | | | | | | Adapter | 75003023 | 2 | 2 places/ adapter |

| Tube vol. (mL) | Vol. fill (mL) | Description | Cat. No. | Qty./pkg. | Tubes/rotor | Max. speed (rpm) | Max. RCF ² (x g) | Dims ØxL (mm) | Required tube closures, adapters, tools & accessories | | | |
|----------------|----------------|----------------------|----------|-----------|-------------|------------------|-----------------------------|---------------|---|----------|-----------|------------------|
| | | | | | | | | | Type | Cat. No. | Qty./pkg. | Description |
| 4.0 | 3.0 | PC Flanged Tube | 03104 | 50 | 16 | 20000 | 47850 | 11 x 75 | Closure | 03264 | 50 | PP Snap-On |
| | | | | | | | | | Adapter | 75003023 | 2 | 2 places/adapter |
| 3.0 | - | BD Vacutainer Tube | - | - | 8 | - | - | 10 x 64 | Adapter | 010-1128 | 2 | 1 place/adapter |
| 1.0 | - | BD Microtainer™ Tube | - | - | 24 | - | - | 8 x 48 | Adapter | 010-1127 | 2 | 3 places/adapter |

Refer to manufacturer's recommendations for product performance information.

Table 86: F21-8x50y rotor labware

6. 16. 5. Biocontainment Certificate

Health Protection Agency
Microbiology Services
Porton Down
Salisbury
Wiltshire
SP4 0JG



Certificate of Containment Testing

Containment Testing of Rotor F21-8x50y in a Thermo Scientific Centrifuge



Report No. 195-12 C

Report Prepared For: Thermo Fisher Scientific

Issue Date: 17th October 2012

Test Summary

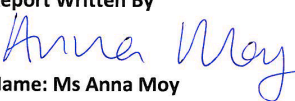
A F21-8x50y rotor was containment tested in a Thermo Scientific centrifuge at 20,000 rpm at partial vacuum, using Annex AA of IEC 61010-2-020:2006 (2nd Ed.). The sealed rotor was shown to contain all contents.

| | |
|--|---|
| Report Written By  Name: Ms Anna Moy Title: Biosafety Scientist | Report Authorised By  Name: Mrs Sara Speight Title: Senior Biosafety Scientist |
|--|---|

Thermo Scientific is a trademark of Thermo Fisher Scientific and is registered with the USPTO.

6.17. Fiberlite F23-48x1.5



6. 17. 1. Items Supplied

| Item | Cat. No. | Quantity |
|---------------------------------|------------|----------|
| Fiberlite F23-48x1.5 Rotor | 096-484075 | 1 |
| Rotor Care Kit | 020-484075 | 1 |
| Hitachi Brand himac-1.5mL Tubes | 010-1216 | 48 |

Table 87: Items supplied F23-48x1.5 rotor

6. 17. 2. Technical Data

| | |
|------------------------------|------------------------|
| Type | Fixed angle |
| Material | Carbon Fiber Composite |
| Net Weight | 4.54 kg/10.0 lbs |
| Capacity | 48 x 1.5 mL |
| Maximum Permissible Load | 48 x 3.2 g |
| Tube Dimensions Ø x L | 11 x 40 mm |
| Radius (max. / min.) | 97 mm / 64 mm |
| Angle | 45° |
| Max. Autoclaving Temperature | 121 °C |

Table 88: F23-48x1.5 rotor technical data

6. 17. 3. Rotor Performance Data

| Centrifuge | LYNX 4000 | LYNX 6000 |
|--|-------------|-------------|
| Maximum Speed | 18 500 rpm | 23 000 rpm |
| Maximum RCF-Value | 37 116 x g | 57 368 x g |
| K-Factor at n_{max} | 307 | 199 |
| Acceleration / Braking Time | 40 s / 50 s | 40 s / 50 s |
| Maximum Speed at 4 °C | 18 500 rpm | 23 000 rpm |
| Min. Sample Temperature at Max. Speed (Ambient Temperature 23 °C, Run Time 60 minutes) | -7 °C | 1 °C |

Table 89: F23-48x1.5 rotor performance data

6. 17. 4. Labware

| Tube vol. (mL) | Vol. fill (mL) | Description | Cat. No. | Qty./pkg. | Tubes/rotor | Max. speed (rpm) | Max. RCF ² (x g) | Dims ØxL (mm) | Required tube closures, adapters, tools & accessories | | | |
|----------------|----------------|-----------------------|-----------|-----------|-------------|------------------|-----------------------------|---------------|---|----------|-----------|--------------|
| | | | | | | | | | Type | Cat. No. | Qty./pkg. | Description |
| 1.5 | 1.5 | Polyallomer Microtube | 314352H01 | 100 | 48 | 23 000 | 57 368 | 11 x 40 | Closure | Included | - | Snap-on Seal |

Refer to manufacturer's recommendations for product performance information.

Table 90: F23-48x1.5 rotor labware

6.18. TCF-20 Continuous Flow and Zonal Rotors

For more information on the TCF-20 rotor, please refer to the separate rotor manual.



Chemical Compatibility

Chemical Compatibility

| MATERIAL | Viton™ | Tygon™ | Titanium | Stainless Steel | Silicone Rubber | Rulon A™, Teflon™ | Polyvinyl Chloride | Polysulfone | Polypropylene | Polyethylene | Polythermide | Polyester, Glass Thermoset | Polycarbonate | Polyallomer | PET ¹ , Polyclear™, Clear Crimp™ | Polyamide/Nylon | Noryl™ | Neoprene | Glass | EPDM rubber | Delrin™ | Composite Carbon Fiber/Epoxy | Polyurethane Rotor Paint | Cellulose Acetate Butyrate | Buna N | Anodic Coating for Aluminum | Aluminium |
|----------------------------|--|--------|----------|-----------------|-----------------|-------------------|--------------------|-------------|---------------|--------------|--------------|----------------------------|---------------|-------------|---|-----------------|--------|----------|-------|-------------|---------|------------------------------|--------------------------|----------------------------|--------|-----------------------------|-----------|
| CHEMICAL | | | | | | | | | | | | | | | | | | | | | | | | | | | |
| 2-MERCAPTOETHANOL | S | U | S | S | S | S | U | S | S | S | S | / | S | S | U | S | S | U | S | / | S | M | S | / | U | S | S |
| ACETALDEHYDE | S | / | S | / | U | S | M | / | M | M | U | U | U | M | / | / | / | U | / | M | / | / | / | U | U | / | S |
| ACETONE | M | U | S | M | M | S | U | U | S | S | U | U | U | S | U | S | U | U | S | S | M | U | S | U | U | S | S |
| ACETONITRILE | S | U | S | S | S | S | U | U | M | S | U | U | U | S | U | S | U | U | S | / | S | M | S | / | U | U | S |
| ALCOHOL™ | U | S | S | S | S | S | S | S | S | S | S | M | M | S | S | S | S | S | S | / | S | S | S | / | U | U | S |
| ALYL ALCOHOL | / | / | S | / | / | S | / | / | S | S | S | M | M | S | S | S | S | U | / | / | / | / | / | U | U | / | S |
| ALUMINUM CHLORIDE | U | S | U | U | M | S | S | S | S | S | / | S | S | S | S | M | S | S | S | S | U | S | S | S | U | U | S |
| FORMIC ACID (100%) | / | U | S | U | / | S | U | / | S | S | U | U | M | S | S | U | / | / | / | / | U | / | / | U | U | S | S |
| AMMONIUM ACETATE | S | S | S | S | S | S | S | S | S | S | / | U | U | S | S | S | S | S | S | / | S | S | S | / | U | U | S |
| AMMONIUM CARBONATE | M | S | S | S | S | S | S | S | S | S | / | U | U | S | S | S | S | S | S | S | S | S | S | / | U | U | S |
| AMMONIUM HYDROXIDE (10%) | U | S | S | S | S | S | S | S | S | S | / | U | U | S | S | S | S | S | S | S | S | S | S | / | U | U | S |
| AMMONIUM HYDROXIDE (28%) | U | S | S | S | S | S | S | S | S | S | / | U | U | S | S | S | S | S | S | S | S | S | S | / | U | U | S |
| AMMONIUM HYDROXIDE (CONC.) | U | S | S | S | S | S | S | S | S | S | / | U | U | S | S | S | S | S | S | S | S | S | S | / | U | U | S |
| AMMONIUM PHOSPHATE | U | S | S | S | S | S | S | S | S | S | / | U | U | S | S | S | S | S | S | S | S | S | S | / | U | U | S |
| AMMONIUM SULFATE | U | S | S | S | S | S | S | S | S | S | / | U | U | S | S | S | S | S | S | S | S | S | S | / | U | U | S |
| AMYL ALCOHOL | S | / | S | / | U | S | / | / | M | S | / | U | U | M | / | / | / | U | / | M | / | / | / | U | U | / | S |
| ANILINE | S | U | S | U | S | S | U | U | M | S | / | U | U | S | U | U | U | U | S | S | S | S | S | / | U | U | S |
| SODIUM HYDROXIDE (<1%) | U | / | S | / | M | S | / | S | S | S | / | M | M | S | / | / | / | M | / | M | / | / | / | U | U | / | S |
| SODIUM HYDROXIDE (10%) | U | / | S | / | M | S | / | S | S | S | / | M | M | S | / | / | / | M | / | M | / | / | / | U | U | / | S |
| BARIUM SALTS | M | S | S | M | S | S | S | S | S | S | / | M | S | S | S | S | S | S | S | S | S | S | S | / | U | U | S |
| S | Satisfactory | | | | | | | | | | | | | | | | | | | | | | | | | | |
| M | Moderate attack, may be satisfactory for use in centrifuge depending on length of exposure, speed involved, etc.; suggest testing under actual conditions of use | | | | | | | | | | | | | | | | | | | | | | | | | | |
| U | Unsatisfactory, not recommended | | | | | | | | | | | | | | | | | | | | | | | | | | |
| / | Performance unknown; suggest testing, using sample to avoid loss of valuable material | | | | | | | | | | | | | | | | | | | | | | | | | | |

Chemical Compatibility

| MATERIAL | CHEMICAL | | | | | | | | | | | | | | | | | | | |
|---|----------|---|---|---|---|---|---|---|---|---|---|---|---|---|---|---|---|---|---|---|
| Viton™ | S | S | S | S | S | S | S | S | S | S | S | S | S | S | S | S | S | S | S | S |
| Tygon™ | U | / | S | S | S | S | S | S | S | S | S | S | M | S | S | / | U | U | S | U |
| Titanium | S | S | S | S | S | S | S | S | S | S | S | U | S | S | / | S | S | M | S | S |
| Stainless Steel | U | / | S | M | M | M | M | M | M | M | M | U | U | U | S | M | S | S | S | S |
| Silicone Rubber | U | M | S | S | S | S | S | S | S | S | S | U | M | / | S | U | S | S | S | S |
| Rulon A™, Teflon™ | S | S | S | S | S | S | S | S | S | S | S | S | S | S | S | S | S | S | S | S |
| Polyvinyl Chloride | U | M | S | S | S | S | S | S | S | S | S | U | M | M | U | M | S | S | S | S |
| Polysulfone | U | / | S | S | S | S | S | S | S | S | S | U | U | U | / | M | S | S | S | S |
| Polypropylene | U | U | S | S | S | S | S | S | S | S | S | M | S | S | U | U | S | S | S | S |
| Polyethylene | M | U | S | S | S | S | S | S | S | S | M | S | S | S | U | M | S | S | S | S |
| Polythermide | U | U | U | / | / | / | / | / | / | / | U | M | M | / | S | S | S | S | S | S |
| Polyester, Glass Thermoset | M | U | S | / | / | / | / | / | / | / | U | U | U | / | M | S | S | S | S | S |
| Polycarbonate | U | U | S | S | S | S | S | S | S | S | U | M | M | U | U | S | S | S | S | S |
| Polyallomer | U | U | S | S | S | S | S | S | S | S | M | S | S | U | U | S | S | S | S | S |
| PET ¹ , Polyclear™, Clear Crimp™ | U | U | S | / | S | S | S | S | S | S | U | S | U | U | U | U | S | S | S | S |
| Polyamide/Nylon | S | S | S | S | S | S | S | S | S | S | M | U | U | U | U | S | S | S | S | S |
| Noryl™ | U | / | S | S | S | S | S | S | S | S | U | S | S | U | U | S | S | S | S | S |
| Neoprene | U | M | S | S | S | S | S | S | S | S | U | S | / | U | U | S | S | S | S | S |
| Glass | S | / | S | S | S | S | S | S | S | S | S | S | / | S | S | S | S | S | S | S |
| EPDM rubber | U | M | S | / | / | / | / | / | / | / | U | / | / | / | U | S | / | S | U | U |
| Delrin™ | M | M | U | S | S | S | S | S | S | S | M | U | U | U | S | S | S | S | S | M |
| Composite Carbon Fiber/Epoxy | U | / | S | S | S | S | S | S | S | S | S | U | U | / | S | S | S | S | S | S |
| Polyurethane Rotor Paint | S | / | S | S | S | S | S | S | S | S | S | U | U | / | S | S | S | S | S | S |
| Cellulose Acetate Butyrate | U | U | M | / | / | U | / | / | / | / | U | U | U | / | S | S | S | S | S | S |
| Buna N | U | U | S | S | S | S | S | S | S | S | U | U | U | U | / | S | S | S | S | S |
| Anodic Coating for Aluminum | S | / | S | / | S | S | S | S | S | S | U | / | / | S | S | S | S | S | S | S |
| Aluminium | S | / | S | / | S | S | S | S | S | S | U | / | / | S | S | S | S | S | S | S |

| | |
|---|--|
| S | Satisfactory |
| M | Moderate attack, may be satisfactory for use in centrifuge depending on length of exposure, speed involved, etc.; suggest testing under actual conditions of use |
| U | Unsatisfactory, not recommended |
| / | Performance unknown; suggest testing, using sample to avoid loss of valuable material |

Chemical Compatibility

| MATERIAL | Viton™ | Tygon™ | Titanium | Stainless Steel | Silicone Rubber | Rulon A™, Teflon™ | Polyvinyl Chloride | Polysulfone | Polypropylene | Polyethylene | Polythermide | Polyester, Glass Thermoset | Polycarbonate | Polyallomer | PET ¹ , Polyclear™, Clear Crimp™ | Polyamide/Nylon | Noryl™ | Neoprene | Glass | EPDM rubber | Delrin™ | Composite Carbon Fiber/Epoxy | Polyurethane Rotor Paint | Cellulose Acetate Butyrate | Buna N | Anodic Coating for Aluminum | Aluminium |
|----------------------------------|--|--------|----------|-----------------|-----------------|-------------------|--------------------|-------------|---------------|--------------|--------------|----------------------------|---------------|-------------|---|-----------------|--------|----------|-------|-------------|---------|------------------------------|--------------------------|----------------------------|--------|-----------------------------|-----------|
| CHEMICAL | S | M | U | U | U | S | U | U | M | U | S | U | U | U | U | U | M | U | S | / | M | U | S | / | U | S | U |
| Phenol (50%) | S | M | U | U | U | S | U | U | M | U | S | U | U | U | U | U | M | U | S | / | M | U | S | / | U | S | U |
| Phosphoric Acid (10%) | S | M | U | U | U | S | U | U | M | U | S | U | U | U | U | U | M | U | S | / | M | U | S | / | U | S | U |
| Phosphoric Acid (conc.) | S | / | U | U | U | S | U | U | M | U | S | U | U | U | U | U | M | U | S | / | M | U | S | / | U | S | U |
| Physiologic Media (Serum, Urine) | S | S | S | S | S | S | S | S | S | S | S | S | S | S | S | S | S | S | S | S | S | S | S | S | S | S | S |
| Picric Acid | S | M | U | U | U | S | U | U | M | U | S | U | U | U | U | U | M | U | S | / | M | U | S | / | U | S | U |
| Pine (60%) | S | M | U | U | U | S | U | U | M | U | S | U | U | U | U | U | M | U | S | / | M | U | S | / | U | S | U |
| Rubidium Bromide | S | S | S | S | S | S | S | S | S | S | S | S | S | S | S | S | S | S | S | S | S | S | S | S | S | S | S |
| Rubidium Chloride | S | S | S | S | S | S | S | S | S | S | S | S | S | S | S | S | S | S | S | S | S | S | S | S | S | S | S |
| Sulphur | S | S | S | S | S | S | S | S | S | S | S | S | S | S | S | S | S | S | S | S | S | S | S | S | S | S | S |
| Sulphur, Alkane | S | S | S | S | S | S | S | S | S | S | S | S | S | S | S | S | S | S | S | S | S | S | S | S | S | S | S |
| Sulfosulphuric Acid | S | S | S | S | S | S | S | S | S | S | S | S | S | S | S | S | S | S | S | S | S | S | S | S | S | S | S |
| Nitric Acid (10%) | S | M | U | U | U | S | U | U | M | U | S | U | U | U | U | U | M | U | S | / | M | U | S | / | U | S | U |
| Nitric Acid (50%) | S | M | U | U | U | S | U | U | M | U | S | U | U | U | U | U | M | U | S | / | M | U | S | / | U | S | U |
| Nitric Acid (95%) | S | M | U | U | U | S | U | U | M | U | S | U | U | U | U | U | M | U | S | / | M | U | S | / | U | S | U |
| Hydrochloric Acid (10%) | S | M | U | U | U | S | U | U | M | U | S | U | U | U | U | U | M | U | S | / | M | U | S | / | U | S | U |
| Hydrochloric Acid (50%) | S | M | U | U | U | S | U | U | M | U | S | U | U | U | U | U | M | U | S | / | M | U | S | / | U | S | U |
| Sulfuric Acid (10%) | S | M | U | U | U | S | U | U | M | U | S | U | U | U | U | U | M | U | S | / | M | U | S | / | U | S | U |
| Sulfuric Acid (50%) | S | M | U | U | U | S | U | U | M | U | S | U | U | U | U | U | M | U | S | / | M | U | S | / | U | S | U |
| Sulfuric Acid (conc.) | S | M | U | U | U | S | U | U | M | U | S | U | U | U | U | U | M | U | S | / | M | U | S | / | U | S | U |
| Stearic Acid | S | M | U | U | U | S | U | U | M | U | S | U | U | U | U | U | M | U | S | / | M | U | S | / | U | S | U |
| Tetrahydrofuran | S | M | U | U | U | S | U | U | M | U | S | U | U | U | U | U | M | U | S | / | M | U | S | / | U | S | U |
| S | Satisfactory | | | | | | | | | | | | | | | | | | | | | | | | | | |
| M | Moderate attack, may be satisfactory for use in centrifuge depending on length of exposure, speed involved, etc.; suggest testing under actual conditions of use | | | | | | | | | | | | | | | | | | | | | | | | | | |
| U | Unsatisfactory, not recommended | | | | | | | | | | | | | | | | | | | | | | | | | | |
| / | Performance unknown; suggest testing, using sample to avoid loss of valuable material | | | | | | | | | | | | | | | | | | | | | | | | | | |

Chemical Compatibility

| MATERIAL | Chemical | 1 | 2 | 3 | 4 | 5 | 6 | 7 | 8 | 9 | 10 | 11 | 12 | 13 | 14 | 15 | |
|--|--------------------------|--|---|---|---|---|---|---|---|---|----|----|----|----|----|----|---|
| Viton™ Tygon™ Titanium Stainless Steel Silicone Rubber Rulon A™, Teflon™ Polyvinyl Chloride Polysulfone Polypropylene Polyethylene Polythermide Polyester, Glass Thermoset Polycarbonate Polyallomer PET ¹ , Polyclear™, Clear Crimp™ Polyamide/Nylon Noryl™ Neoprene Glass EPDM rubber Delrin™ Composite Carbon Fiber/Epoxy Polyurethane Rotor Paint Cellulose Acetate Butyrate Buna N Anodic Coating for Aluminum Aluminium | TOLUENE | M | U | S | S | S | S | S | S | S | S | S | S | S | S | S | |
| | TRICHLOROACETIC ACID | U | M | / | / | / | / | / | / | / | / | / | / | / | / | / | |
| | TRICHLOROETHANE | U | M | / | / | / | / | / | / | / | / | / | / | / | / | / | / |
| | TRICHLOROETHYLENE | U | M | / | / | / | / | / | / | / | / | / | / | / | / | / | / |
| | TRISODIUM PHOSPHATE | U | M | / | / | / | / | / | / | / | / | / | / | / | / | / | / |
| | TRIS BUFFER (NEUTRAL pH) | U | M | / | / | / | / | / | / | / | / | / | / | / | / | / | / |
| | TRITON X/100™ | U | M | / | / | / | / | / | / | / | / | / | / | / | / | / | / |
| | UREA | U | M | / | / | / | / | / | / | / | / | / | / | / | / | / | / |
| | HYDROGEN PEROXIDE (10%) | U | M | / | / | / | / | / | / | / | / | / | / | / | / | / | / |
| | HYDROGEN PEROXIDE (3%) | S | M | / | / | / | / | / | / | / | / | / | / | / | / | / | / |
| | XYLENE | S | M | / | / | / | / | / | / | / | / | / | / | / | / | / | / |
| | ZINC CHLORIDE | U | M | / | / | / | / | / | / | / | / | / | / | / | / | / | / |
| | ZINC SULFATE | U | M | / | / | / | / | / | / | / | / | / | / | / | / | / | / |
| | CITRIC ACID (10%) | M | U | S | S | S | S | S | S | S | S | S | S | S | S | S | S |
| | S | Satisfactory | | | | | | | | | | | | | | | |
| | M | Moderate attack, may be satisfactory for use in centrifuge depending on length of exposure, speed involved, etc.; suggest testing under actual conditions of use | | | | | | | | | | | | | | | |
| | U | Unsatisfactory, not recommended | | | | | | | | | | | | | | | |
| | / | Performance unknown; suggest testing, using sample to avoid loss of valuable material | | | | | | | | | | | | | | | |

¹ Polyethylene terephthalate

NOTICE Chemical resistance data is included only as a guide to product use. Because no organized chemical compatibility data exists for materials under the stress of centrifugation, when in doubt we recommend pretesting sample lots.

Index

A

A21-24x15c 72
A22-24x16 75
A23-6x100 78
A27-6x50 82
A27-8x50 86
Aerosol-tight Applications 35
Autoclaving 43

B

Before installing a rotor 26
BIOFlex HC 55
BIOFlex HS 60
Bolting Down the Centrifuge (optional) 15

C

Care 39
Centrifugation 33
Cleaning 41
Cleaning Intervals 39
Control Panel 22

D

Decontamination 42
Directives 53
Disinfection 42
Disposal 44

E

Entering Centrifugation Parameters 30

F

Fiberlite F9-6x1000 LEX 90
Fiberlite F10-4x1000 LEX 95
Fiberlite F12-6x500 LEX 100
Fiberlite F14-6x250y 104
Fiberlite F14-14x50cy 108
Fiberlite F20-12x50 LEX 111
Fiberlite F21-8x50y 114
Fiberlite F23-48x1.5 117

G

Guidelines 53

H

How to Operate a Rotor 26

I

Ice Formation 46
Incorrect Loading 29
Information for the Customer Service 48
Intended Use 8
Items Supplied 7

L

Lifetime 44

List of Centrifuges 50

List of Rotors 50

Loading the Rotor 28

Location 14

M

Mains Connection 20
Mains Supply 54
Maintenance 39, 43
Maximum Loading 29
Mechanical Emergency Door Release 45

O

Operation 22

P

Power the Centrifuge On and Off 25
Product Features 49
Product Features and Materials Used 49
Programmed Operation 34
Proper Rotor Handling 27

R

Refrigerants 54
Remove the Rotor 35
Rotor Specifications 55

S

Safety Instructions 11
Standards 53

T

T29-8x50 68
TCF-20 Continuous Flow and Zonal Rotors 118
Technical Specifications 49, 51
TH13-6x50 64
Transport and Set Up 14
Troubleshooting 45
Troubleshooting Guide 46

U

Unpacking 14
Useful Features 38



Thermo Electron LED GmbH
Zweigniederlassung Osterode
Am Kalkberg, 37520 Osterode am Harz
Germany



Thermo Scientific LYNX Series

50171087 is the original instruction manual.

[thermofisher.com](https://www.thermofisher.com)

© 2025 Thermo Fisher Scientific Inc. All rights reserved.

All trademarks are the property of Thermo Fisher Scientific Inc. and its subsidiaries unless otherwise indicated.

Delrin is a registered trademark of Dupont Polymers, Inc. TEFLON and Viton are registered trademarks of The Chemours Company FC. Noryl and Valox are registered trademarks of Sabic Global Technologies. POLYCLEAR is a registered trademark of Hongye CO., Ltd. Hypaque is a registered trademark of Amersham Health AS. RULON A and Tygon are registered trademarks of Saint-Gobain Performance Plastics. Alconox is a registered trademark of Alconox, Inc. Ficoll is a registered trademark of Cytiva Sweden AB. Haemo-Sol is a registered trademark of Haemo-Sol International, LLC. Triton is a registered trademark of Union Carbide Corporation.

Specifications, terms and pricing are subject to change. Not all products are available in all countries. Please consult your local sales representative for details.

Shown pictures within the manual are examples and may differ considering the set parameters and language. Pictures of the user interface within the manual are showing the English version as example.

Australia
+61 39757 4300

Austria
+43 1 801 40 0

Belgium
+32 53 73 42 41

China
+800 810 5118
or +400 650 5118

France
+33 2 2803 2180

Germany national toll free
0800 1 536 376

Germany international
+49 6184 90 6000

India
+91 22 6716 2200

Italy
+39 02 95059 552

Japan
+81 3 5826 1616

Netherlands
+31 76 579 55 55

New Zealand
+64 9 980 6700

Nordic/Baltic/CIS countries
+358 10 329 2200

Russia
+7 812 703 42 15

Spain/Portugal
+34 93 223 09 18

Switzerland
+41 44 454 12 12

UK/Ireland
+44 870 609 9203

USA/Canada
+1 866 984 3766

Other Asian Countries
+852 2885 4613

Countries not listed
+49 6184 90 6000