



**Anton Paar**

# Physica MCR

The Modular Rheometer Series

::: Intelligence in Rheometry



# Physica MCR

## Modular Compact Rheometer

At Anton Paar we have a close relationship with our customers, are constantly searching for answers and pushing back physical and technical boundaries. We enjoy the challenge of research and development and take pride in our achievements. The result: customers receive instruments produced to the highest level of technical perfection, tailored to meet their special needs.

### Key factors in our success:

- ▶ Highly motivated employees working on their own initiative.
- ▶ More than 20% of the yearly turnover invested in R&D.
- ▶ Long-term investment in and cultivation of key technologies.
- ▶ An international sales and service network.
- ▶ Efficient and respectful use of both natural and human resources.
- ▶ A flat decision-making structure consisting of responsible teams.
- ▶ A charitable foundation as the owner.
- ▶ Thorough and continuous training of employees and apprentices.

Over the last ten years, the development of Physica rheometers has been characterized by innovation and the continuous integration of new technologies in the design concept. In keeping with our company philosophy, all improvements were made with the customer in mind, whether that be providing additional technical features or making the instruments easier to use. The new Physica MCR rheometer series is the result of this process.

Setting the standard for rheological measurements since its introduction in 1999, the new MCR series raises the bar even higher.

Discover the difference that years of innovation can make!

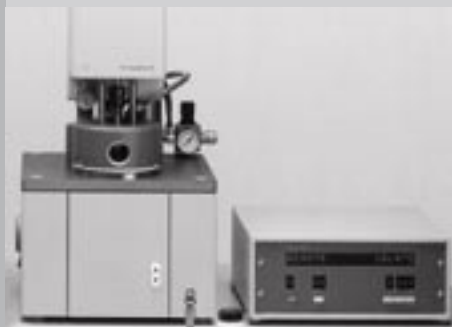

**1990**  
Introduction of  
Physica Rheolab



**1995**  
Introduction of  
Physica UDS 200



**1999**  
Introduction of  
Physica MCR 300

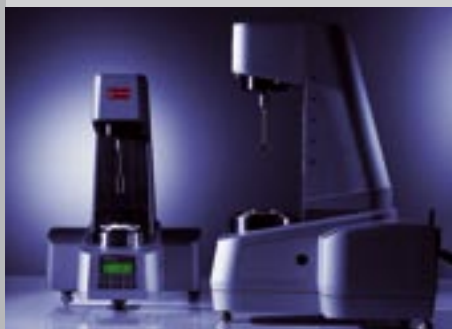

**Now**  
Introduction of the new  
Physica MCR series:  
51, 101, 301, 501

# Physica MCR

## The Success Story Continues

### The idea

Galileo Galilei's vision is the driving force behind the new Physica MCR rheometer series: "Measure what is measurable, and make measurable that which is not."

Fulfilling this vision required input from customers, developing the third generation of components, and implementing the use of new technologies. The result: an innovative rheometer series which extends the measuring possibilities to new levels!

From the basic configuration for quality control to the high-end model for research and development, we have made the new series of MCRs easier to use, more accurate, and have extended the range of applications through the innovative use of new technologies.

### The concept

The new Physica MCR series is based on technical concepts at the cutting edge of technology. The revolutionary modular design features innovations such as the Toolmaster™ – the first automatic measuring and accessory detection system, TruGap™ - a patented measuring gap detection system (US-Patent 6,499,336), an extended torque range, a patented normal force sensor (US-Patent 6,167,752) with improved normal force capabilities, and unprecedented thermal stability of the normal force signal.

The Physica MCR series incorporates modern design with a compact, low-compliance frame which houses both the mechanical and electronic control components. It provides a wide selection of measurement geometries, interchangeable environmental systems and special accessories.

All the main components, such as the motor, air bearing, electronic control units, and frame have been optimized using state-of-the-art technologies.



LARGE TEMPERATURE RANGES  
TEMPERATURE  
CONTROL SYSTEMS  
TO PREVENT TEMPERATURE  
GRADIENTS WITHIN THE SAMPLE

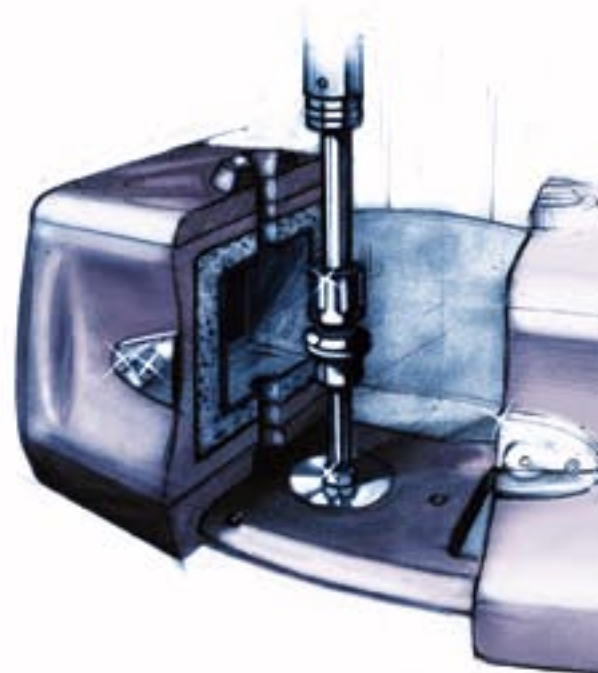

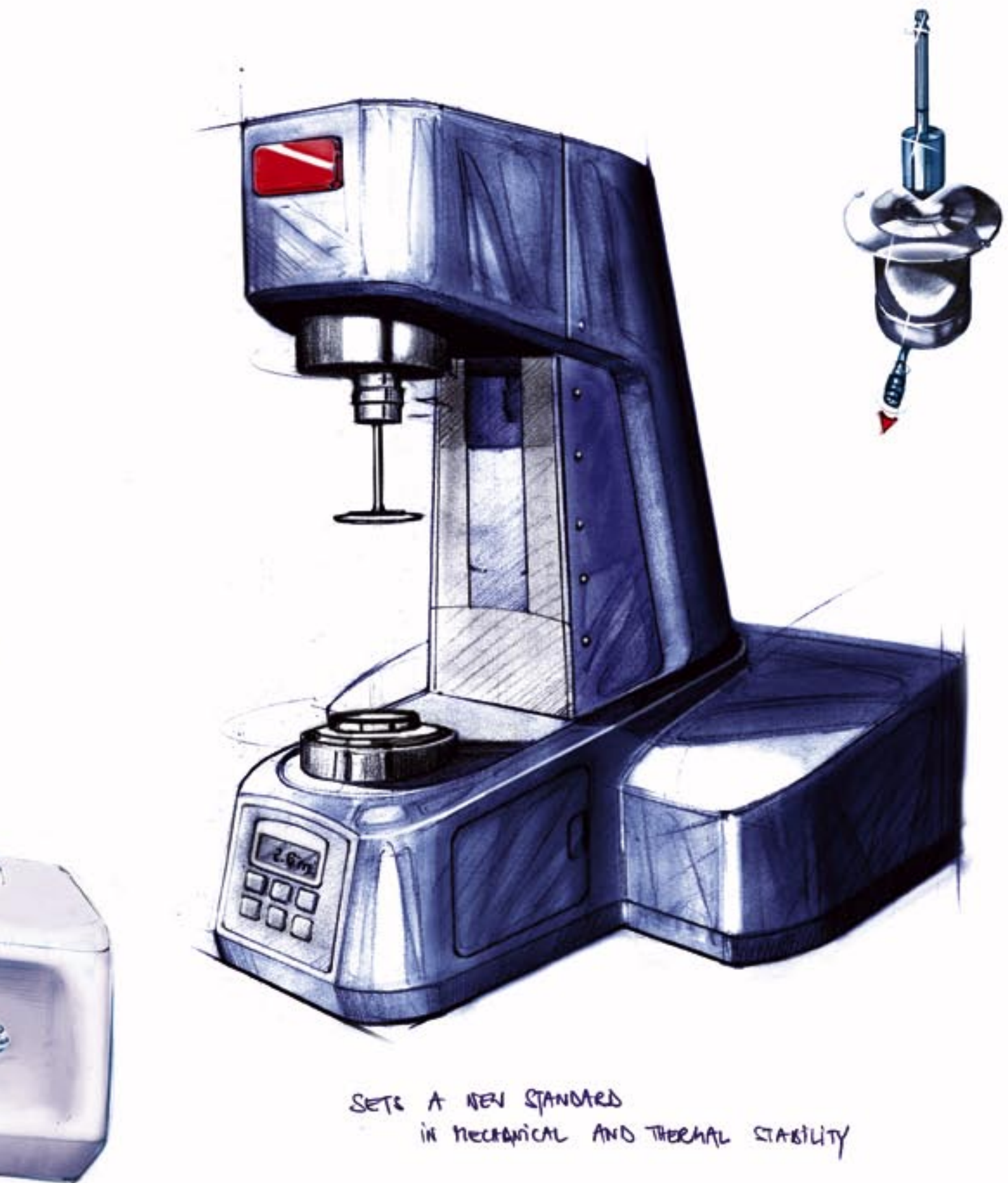

SETS A NEW STANDARD  
in MECHANICAL AND THERMAL STABILITY

## TOOLMASTER™

JUST CONNECT THE GEOMETRY  
AND ENVIRONMENTAL SYSTEM -  
EVERYTHING ELSE IS DONE  
AUTOMATICALLY BY THE TOOLMASTER



## TRU GAP™

THE SYSTEM  
FOR AN EXACT  
MEASUREMENT AND  
CONTROL OF THE  
REAL GAP SIZE



## REVOLUTIONARY SYNCHRONOUS MOTOR

WITH IMPROVED EFFICIENCY  
LARGER TORQUE RANGE AND  
FASTER RESPONSE TIMES



# The Technologies

## Simple and sophisticated: The housing and frame

Ergonomics and functionality were the major design goals behind the compact, modern housing and frame. All the mechanical and electrical control components are incorporated into one single unit.

- ▶ Fast and simple exchange of environmental systems and accessories.
- ▶ Integrated instrument requiring minimum laboratory space; easy installation.
- ▶ Extremely rigid and stable frame for optimized mechanical and thermal stability.
- ▶ Machined to perfection for durability and longevity.
- ▶ Large working area provides optimal access for sample loading and trimming.
- ▶ Easy to clean.

## High resolution: The optical encoder

A high-resolution optical encoder using data oversampling technology enables precise measurements of the angular deflection. This, combined with our proprietary Direct Strain Oscillation (DSO) method, provides the ability to control oscillatory strains as low as  $0.1 \mu\text{rad}$  – important for studying material with delicate structures. There is no limit to the upper value of the amplitude.

## Unrivaled precision: The air bearing

Together with the synchronous motor, the new, very rigid air bearing in the Physica MCR 101/301/501 series sets new standards in drift stability and low torque capabilities. A patented normal force sensor (US-Patent 6,167,752) located inside the air bearing performs a capacitive measurement and detects the natural movement of the bearing due to applied normal forces.

Calling on our many years of experience with air bearing technology, we were once again able to push back the boundaries and develop air bearings which have unmatched accuracy and stability.

- ▶ Position-sensitive torque mapping reduces residual torques to insignificant levels for measurements at the lowest torque values.
- ▶ Excellent normal force measurement with minimal signal drift and high thermal stability is available for all environmental systems and accessories.
- ▶ All bearings are machined and mounted in-house and undergo exhaustive quality control testing. This guarantees the highest quality and reliability of these components.



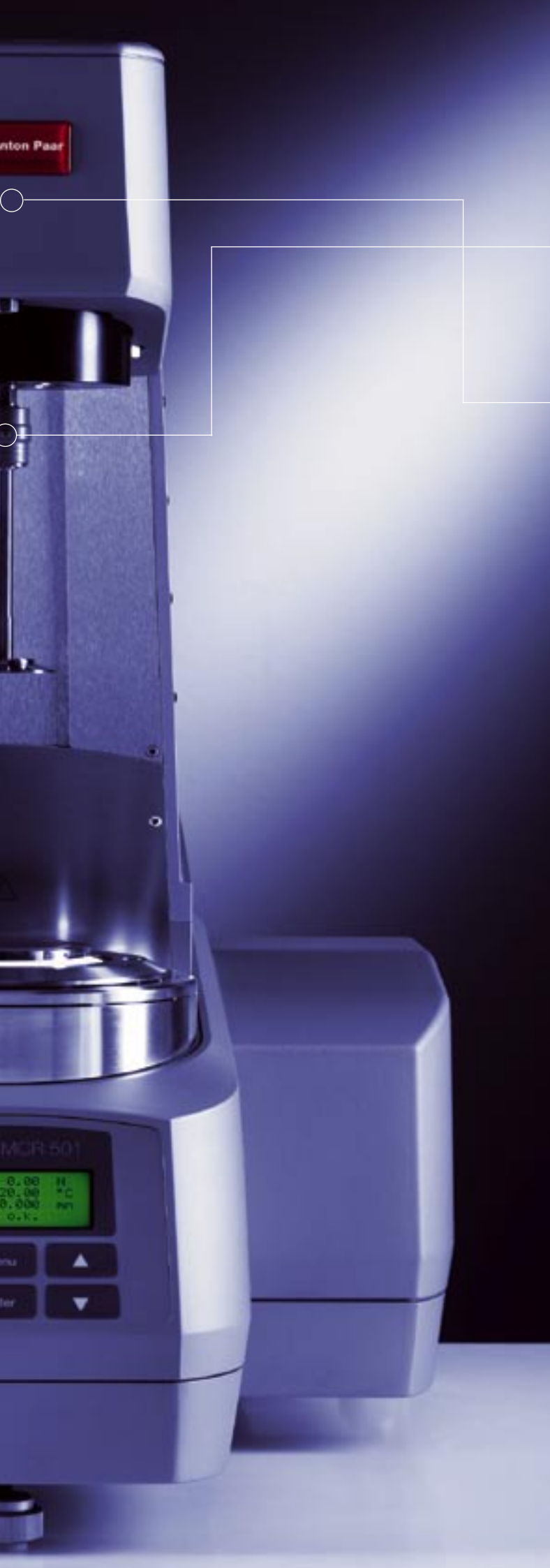

### Maximum ease of use: The quick-fitting coupling

All Physica rheometers have a quick-fitting coupling for maximum ease of use. Geometries can be changed in seconds.

### Tireless response: The motor drive

#### Principle

The air bearing-supported synchronous motor is one of the unique key components of the Physica MCR rheometer series. High-energy permanent magnets mounted on a small rotor disc produce a constant magnetic field, providing fast, delay-free response. The rotor moves at the same speed, i.e. synchronous, with the stator field, which is produced by a series of coils.

It is possible to adjust the torque in such a way that it is linear to the total amount of stator current. A change in the stator current therefore causes a simultaneous change in the torque. In contrast to induction motors, the rotor field in a synchronous motor does not change. This means there are no eddy currents causing heating problems, which significantly alter the motor characteristics and lead to signal drifts. Rapid, linear response coupled with advanced control electronics results in unmatched speed and strain control.

#### Advantages

- ▶ Highest efficiency.
- ▶ Absolute torque calibration due to the linear relationship between the electro-magnetic motor torque and the stator current.
- ▶ Suitable for all CSS and CSR tests over large stress, strain and frequency ranges.
- ▶ The Direct Strain Oscillation (DSO) function enables strain-controlled oscillatory tests at the smallest torques and deflection angles.
- ▶ The constant rotor field means no heat production and no unwanted signal drifts.
- ▶ No overshoots in CSS and CSR tests.
- ▶ Over seven decades of torque.
- ▶ Speeds as low as  $10^{-6} \text{ min}^{-1}$  can be set easily. For example: a simple shear flow test for direct measurement of the zero shear viscosity of high molecular weight polymer melt.
- ▶ Excellent speed control over more than 9 decades.
- ▶ Precision air bearing allows accurate measurements at extremely low torques.
- ▶ Fast response for step tests.

# Unique and Error-free

## Unique and error-free: The Toolmaster™

The revolutionary Toolmaster™ represents the first completely automatic tool recognition and configuration system.

All Physica measurement geometries and environmental systems are recognized automatically as soon as they are connected to the rheometer.

With QuickConnect, the measuring geometries are easily connected to the instrument using the reliable Physica quick-fitting coupling. A transponder chip integrated in the geometry contains all relevant geometry data, which are automatically transferred to the software. The data from the connected environmental system or accessory is initialized in the software by SmartLink.

### Advantages

- ▶ No more errors resulting from a user inserting the wrong geometry or making the wrong selection in the software.
- ▶ Intelligent auto-configuration system for user-specific rheometer packages.
- ▶ Calculation of exact geometry factors using real geometry data, e.g. truncation, diameter and cone angle.
- ▶ Unique identification of individual measuring geometries by the transfer of geometry serial numbers.
- ▶ No more errors when documenting a configuration – perfect for traceable documentation (e.g. 21CFR Part11)



Mega. System:	<input type="text" value="CP 50-2 SN0301"/>
Meas. Cell:	<input type="text" value="P-PTD200+H-PTD200"/>
Measuring Gap:	<input type="text" value="0,050"/> mm

# True Innovation



## True innovation: The TruGap™ function

For the first time it is possible to monitor and control the real gap in cone-and-plate or parallel-plate measurements. The new, patented (US Patent 6,499,336) technology is based on an induction method which determines the exact gap size, therefore eliminating errors from thermal expansion and normal force.

The TruGap™ function is available for Peltier elements, electrically heated, and convection-based environmental systems. It uses special measuring geometries and lower plates for each environmental system.

### Advantages

- ▶ Allows truly accurate temperature sweeps with cone-and-plate geometries.
- ▶ Works over wide temperature ranges and heating rates.
- ▶ Determination of the measuring gap at all times, independent of the rheological test.

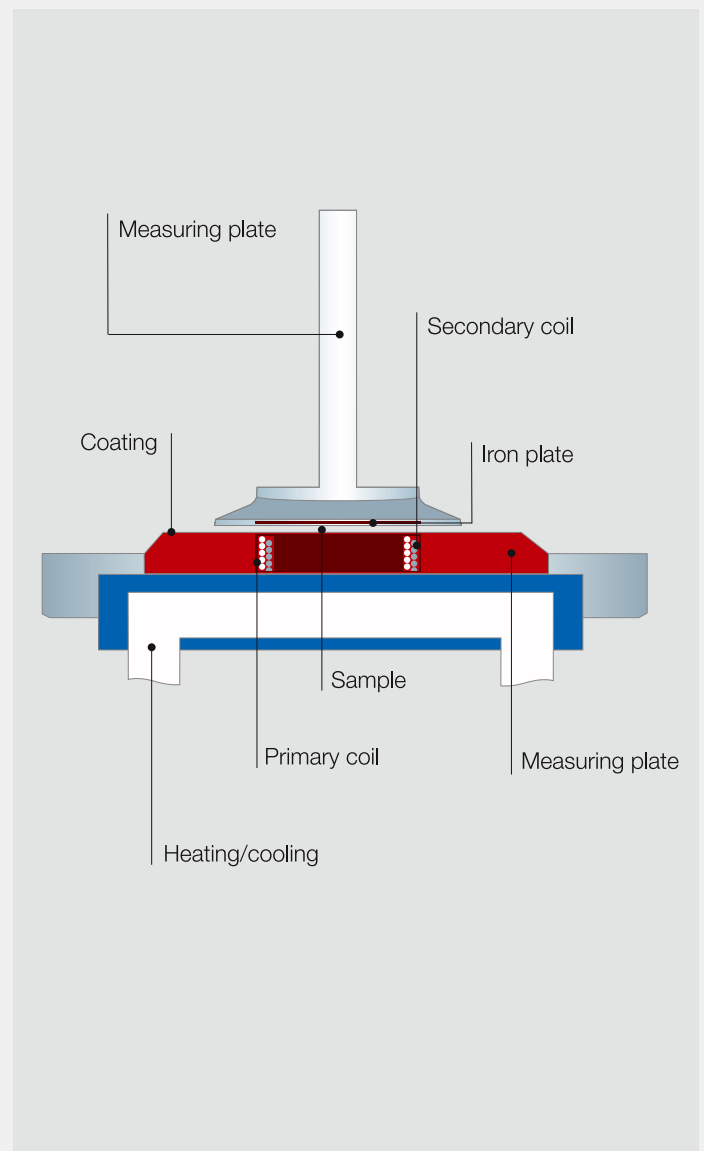

# Environmental Systems, Accessories and Geometries

## Temperature control technologies

Temperature greatly influences the rheological behavior of almost all substances. For this reason, Anton Paar engineers have invested a lot of time and effort in the development of new temperature control systems. The result is a complete range of environmental systems using a number of temperature control technologies. All the temperature control systems are highly accurate, with minimal thermal gradients. In addition, traceable automatic temperature calibration sensors are available to ensure the system is always operating within specification. The product line covers a temperature range from  $-150\text{ }^{\circ}\text{C}$  to  $+1000\text{ }^{\circ}\text{C}$ .

## Environmental systems for the MCR rheometer series

### Cone-and-plate/parallel-plate thermal chambers

- ▶ Liquid temperature control ( $-30$  to  $+180\text{ }^{\circ}\text{C}$ ).
- ▶ Peltier temperature control ( $-40$  to  $+200\text{ }^{\circ}\text{C}$ ).
- ▶ Electrical resistance heating with low temperature option ( $-130$  to  $+400\text{ }^{\circ}\text{C}$ ).
- ▶ Convection oven ( $-150$  to  $+1000\text{ }^{\circ}\text{C}$ ).

### Concentric cylinder thermal chambers

- ▶ Liquid temperature control ( $-30$  to  $+180\text{ }^{\circ}\text{C}$ ).
- ▶ Peltier temperature control ( $-20$  to  $+200\text{ }^{\circ}\text{C}$ ).
- ▶ Electrical resistance heating (RT to  $+300\text{ }^{\circ}\text{C}$ ).

## Additional accessories for the MCR rheometer series

- ▶ Pressure cells.
- ▶ UV chambers for UV-curing inks, adhesives, and coatings.
- ▶ Magneto-rheology and electro-rheology systems.
- ▶ Measuring chamber for starch gelatinization testing.
- ▶ Interfacial rheology measuring cell.
- ▶ Immobilization cell for controlled drying of dispersions, e.g. paper coatings.
- ▶ Rotating ball measuring system for samples containing large particles.
- ▶ Dielectric measuring system.
- ▶ Standardized solid bar and film fixtures for DTMA testing.
- ▶ Additional options for simultaneous structural investigations, e.g. Small Angle Light Scattering (SALS), Small Angle Neutron Scattering (SANS), Small and Wide Angle X-Ray Scattering (SAXS/WAXS) as well as chambers for flow visualization, microscopy and particle imaging velocimetry (PIV).

## Geometries

Anton Paar offers a wide selection of different geometries for concentric cylinder, cone-and-plate and parallel-plate systems for the Physica MCR rheometer series. Almost any diameter, cone angle, truncation, surface treatment, coating and material can be supplied to cover all application needs. Special geometries include stirrers, disposable systems, and customer-specific designs for unique samples and applications.



## Peltier temperature control

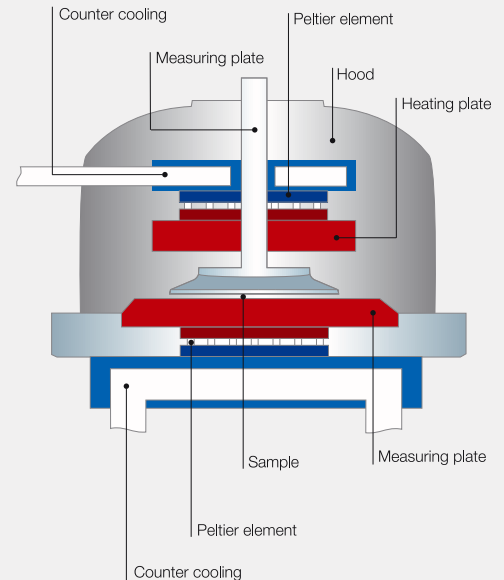

## Electrical resistance heating

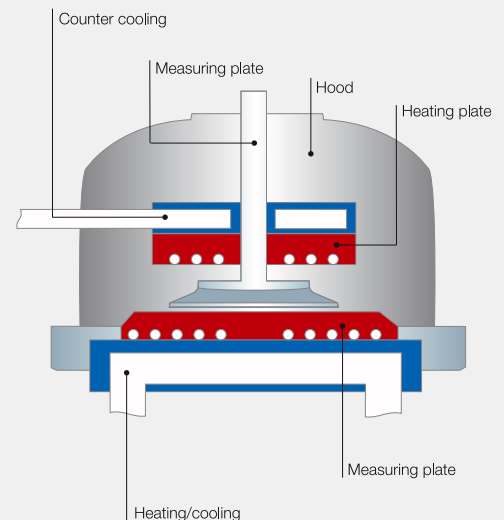

## Convection oven

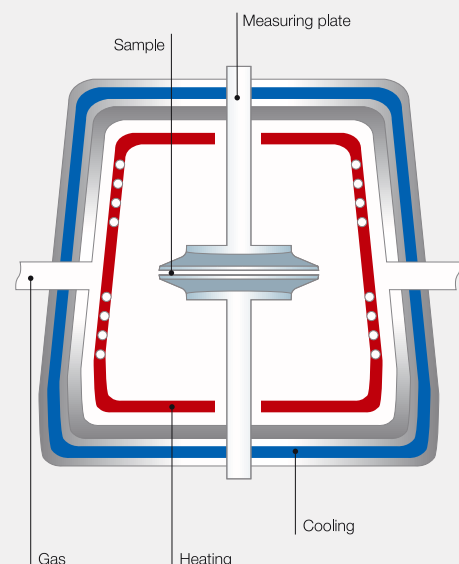

# Physica RheoPlus

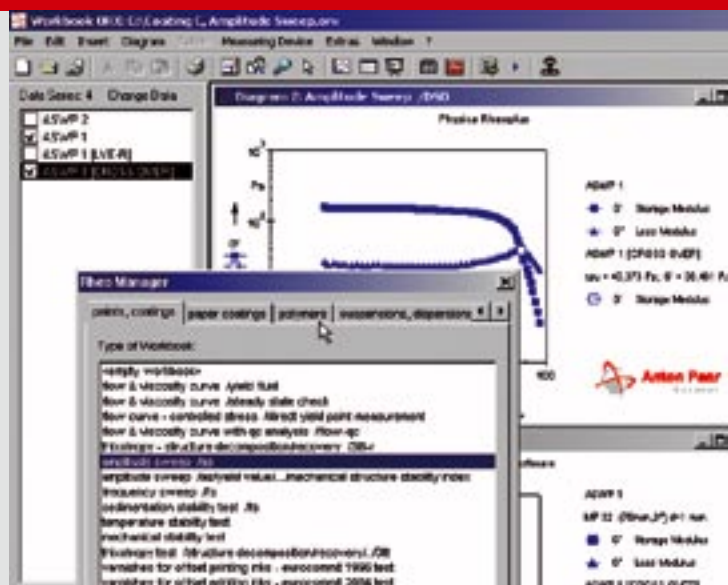

Like our rheometers, the Physica RheoPlus user software is a modular system which can be configured to meet individual requirements, from quality assurance to R&D. RheoPlus is multilingual, speaking to users in the language of their choice.

## RheoManager

The RheoManager helps users who are new to the software or rheology in general. It condenses our application know-how and suggests suitable measuring methods for a large number of applications. Standardized methods for numerous industrial branches are easy to find. Over 70 methods and 200 templates are provided.

Of course, users can also create and manage their own test profiles. The file structure helps keep files under control even when managing a large amount of data.

Convenient analysis routines are an integral part of the predefined RheoManager templates. All analysis routines run in RheoManager can be adapted to suit individual needs and organized in an analysis script. Reports can be configured automatically, and "pass/fail" tests are easily developed using the automation feature.

## Auto-configuration

The Toolmaster™ is an intelligent configuration system, which automatically transfers geometry data and control parameters for the measuring and temperature control systems to the RheoPlus. This eliminates user errors, which can occur when manually entering data for accessories.

## Compatibility

Users of Microsoft® Office will recognize many of the features in the RheoPlus software and use them intuitively. Drag & drop is just one of the many features which make working with RheoPlus easy and efficient. Data from earlier Physica software versions can be imported and data and graphs from RheoPlus are easily exported into MS Excel®, MS Word® or as ASCII data.

## Reliability

Physica RheoPlus was developed according to ISO 9001 guidelines and runs as C/C++ software for the latest Windows™ operating systems. The electronic signature, audit trail, archiving and retrieval of data comply with the regulations in 21 CFR Part 11 from the US Food and Drug Administration (FDA).

## PC connection

The LIMS-SAP module means results can be automatically saved in an external data base. Measuring profiles can also be activated by other programs via the interface, allowing users to work through the script.

RheoPlus is the first rheometer software to provide both a serial interface (RS 232) and an Ethernet interface for communicating with the instrument.

## Flexibility

There are no limits for programming and linking test sequences. Test types can be combined in real time in whichever order required. Additional instruments or signals such as power supplies, relays and magnetic valves are supported by RheoPlus in real time and can be synchronized with the rheological measuring profile. This makes RheoPlus the perfect platform for setting up measuring procedures which simulate processes and applications.

# Applications

**Fig. 1: FLOW AND VISCOSITY CURVE...or: how to get information about the flowability of a polymer**

Flow and viscosity curves reveal information about the flowability of polymers under different shear and simulated process conditions. The zero shear viscosity  $\eta_0$  at low shear rates is an important material property and is directly proportional to the average molar mass  $M_w$ . To determine a viscosity curve over a broad range of shear rates, a master curve can be calculated using the time-temperature superposition (TTS) in combination with the conversion method according to the Cox-Merz rule.

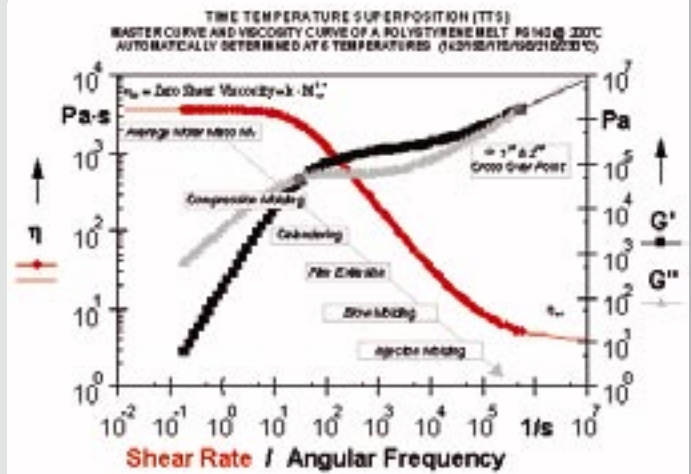

**Fig. 2: AMPLITUDE SWEEP...or: how to determine the deformation stability and yield stress of a suspension or emulsion**

Rotational tests, often used in the past, can deliver very different results when calculating the yield stress. Using  $G'$  and  $G''$  of an amplitude sweep with preset strain (Direct Strain Oscillation, DSO) plotted over the shear stress permits more reliable and practically relevant results for the yield stress value. Significant parameters for evaluating the mechanical stability of a material can be calculated using automated analysis routines in the software.

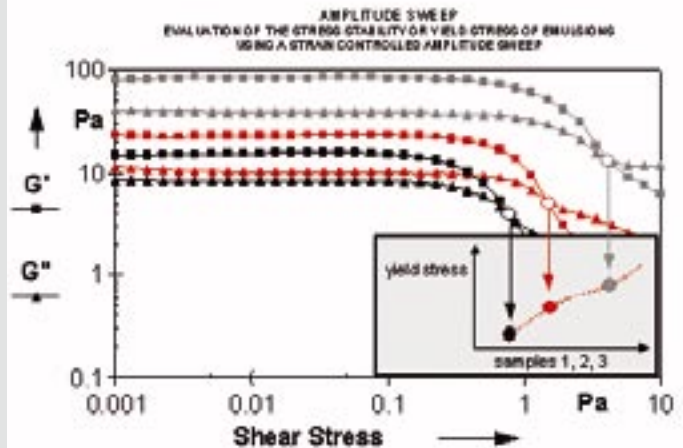

**Fig. 3: INTERVAL THIXOTROPY TEST...or: how to measure the structural regeneration of a material after a short period of high shear**

Almost every coating process consists of 3 phases (1 – at rest, 2 – structural decomposition, 3 – structural regeneration). In Fig. 3, the material's behavior is described by  $G'$  and  $G''$  over time. Time-dependent effects such as leveling and sagging, dot sharpness, layer thickness and separation stability of emulsions and dispersions can be correlated directly to the curve progression.

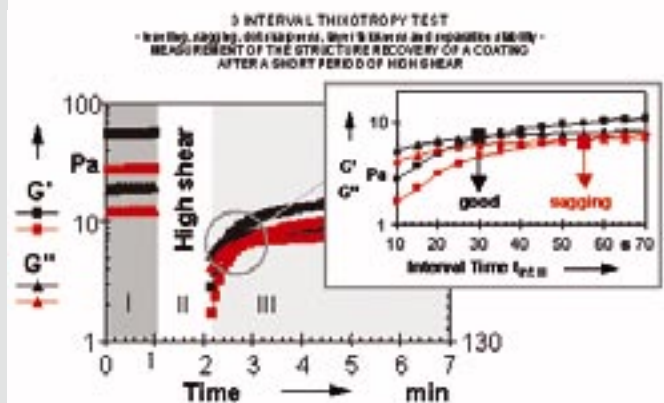

**Fig. 4: TEMPERATURE TEST...or: how important is a closed temperature control system for reproducible results?**

The same ice cream sample was measured in a Peltier system with an actively heated hood (closed system) and in a Peltier system without a hood (open system). As can be seen in Fig. 4, the values of  $G'$  and  $G''$  are much lower when measured by the open system compared to the measurements from the closed system. Samples in the closed system have a higher average sample temperature. Due to the large temperature gradients, samples measured in the open system have shallower curves. In short: the open system cannot describe the melting process of the ice cream accurately enough.

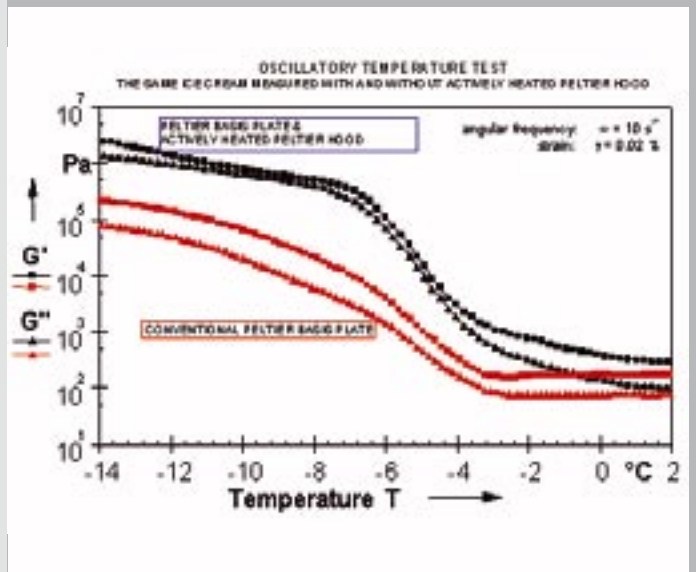

**Fig. 5: TRANSIENT TEST TYPES (creep, stress relaxation tests)...or: what can we learn from the first normal stress difference?**

Step stress (creep & recovery), step strain (stress relaxation) and step rate (stress growth / start-up flow) experiments are typically performed to measure the transient response of a material to a given constant shear stress, strain or rate. Besides the shear viscosity, the measurement of the first normal stress difference  $N_1$  and coefficient  $\psi_1$  also gives valuable information about the sample. Physica MCR rheometers include a patented normal force sensor (US-Patent 6,167,752) which allows the evaluation of the first normal stress difference  $N_1$  and the coefficient  $\psi_1$  over a large range with virtually no thermal drift.

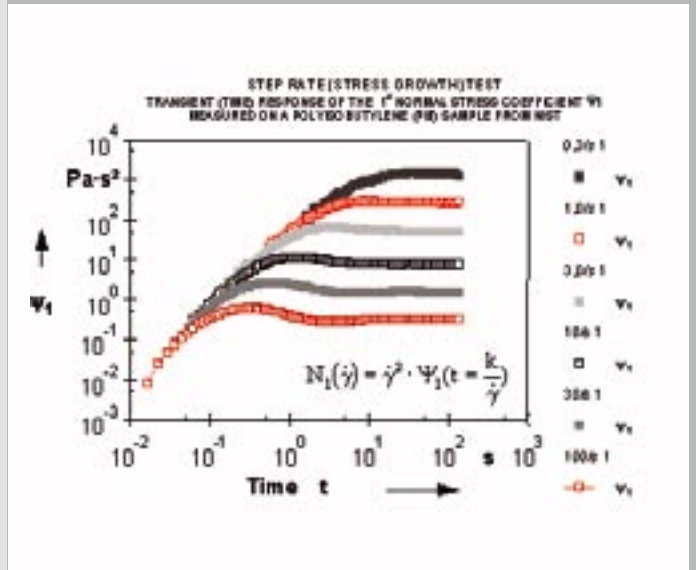

**FIG. 6: COMBINATION OF SMALL ANGLE LIGHT SCATTERING AND RHEOLOGY...or: how to get information about both the micro and macrostructure**

The combination of a Physica MCR rheometer and the small angle light scattering (SALS) system enables the simultaneous determination of microstructural properties (using the optical method) and macroscopic, or bulk, material properties (using rheology).

The flow behavior of a polymer blend (1% Polyisobutylene (PIB) in Polydimethylsiloxane (PDMS)) can be explained by looking at the scattering images. At rest and in the zero viscosity range the scattering patterns have a symmetrical shape. This is due to the circular PIB droplets in the PDMS matrix. At higher shear rates, the viscosity decreases and the sample starts to flow. The scattering patterns become elliptical, indicating an orientation and deformation of the PIB domains in the direction of flow.

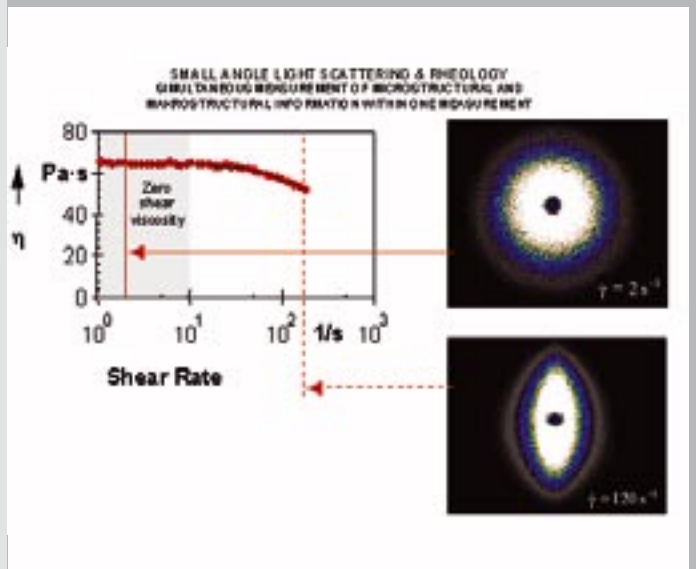

# Specifications

	Unit	Physica MCR 51	Physica MCR 101	Physica MCR 301	Physica MCR 501
<b>Bearing</b>		mechanical	air	air	air
<b>Min. torque</b>	µNm	250	0.5	0.1	0.1
<b>Min. torque DSO</b>	µNm	-	-	0.02	0.02
<b>Max. torque</b>	mNm	125	125	200	230
<b>Torque resolution</b>	µNm	<0.1	0.002	0.001	0.001
<b>Deflection angle (preset)</b>	µrad	1 to ∞	1 to ∞	0.1 to ∞	0.1 to ∞
<b>Internal angular resolution</b>	µrad	0.012	0.012	0.012	0.012
<b>Min. speed (CSS)</b>	1/min	10 <sup>-5</sup>	10 <sup>-6</sup>	10 <sup>-7</sup>	10 <sup>-7</sup>
<b>Min. speed (CSR)</b>	1/min	10 <sup>-3</sup>	10 <sup>-4</sup>	10 <sup>-6</sup>	10 <sup>-6</sup>
<b>Max. speed</b>	1/min	3000	3000	3000	3000
<b>Min. frequency</b>	Hz	10 <sup>-4</sup>	10 <sup>-4</sup>	10 <sup>-5</sup>	10 <sup>-5</sup>
<b>Max. frequency</b>	Hz	100	100	100	100
<b>Normal force range</b>	N	-	0.1 to 30	0.01 to 50	0.01 to 50
<b>Normal force resolution</b>	N	-	0.02	0.002	0.002
<b>Direct Strain Oscillation</b>		no	no	optional	yes
<b>Toolmaster™</b>		yes	yes	yes	yes
<b>TruGap™</b>		no	no	optional	yes
<b>Temperature range</b>	°C	-150 to +1000	-150 to +1000	-150 to +1000	-150 to +1000
<small>Depending on the environmental system used</small>					
<b>Accessories and environmental systems</b>		all	all	all	all
<b>Dimensions (W x D x H)</b>	mm	440 x 600 x 620	440 x 600 x 620	440 x 600 x 620	440 x 600 x 720
<b>Weight</b>	kg	43	43	43	50

## Physica MCR 51

- ▶ A robust rheometer utilizing ball bearings for quality assurance and production control. Ideal for high viscosity applications where low torque capability is not required.

## Physica MCR 101

- ▶ Air bearing rheometer (basic configuration) for quality assurance and product development.
- ▶ The torque range and angle of deflection are ideal for structured materials (pastes, crèmes, lotions, suspensions, emulsions).

## Physica MCR 301

- ▶ Air bearing rheometer for product development and research.
- ▶ The torque range and angular resolution are ideal for all samples from low viscous liquids up to solids.

## Physica MCR 501

- ▶ Air bearing, high-end rheometer for research and development.
- ▶ The widest torque range for the most demanding rheological measurements on all samples from liquids to solids.
- ▶ TruGap™ and DSO are standard for increased accuracy and reproducibility.
- ▶ Expanded housing and frame for customized extension modules.
- ▶ Optimized motor and air bearing system to eliminate external influences and ensure the highest accuracy.



# We Accompany Our Customers



## Total expertise assures flexibility

Anton Paar has a long tradition of experienced and highly skilled employees researching and developing key technologies. All components of the MCR rheometers are manufactured at our high-precision facilities, certified to ISO 9001. The rigorous quality control throughout the whole development and production process is essential for attaining the high quality we expect from our instruments.

## Application know-how

We are proud to provide our customers with unmatched application know-how in the field of rheology. New applications are constantly tested and analyzed in our laboratories. In addition to our own rheology book, we offer a comprehensive collection of publications, application reports, and technical information covering all aspects of rheological testing.

## Learn from the experts

When performing and interpreting rheological measurements, it is especially important to have a good understanding of the rheological background and the correlation between the rheological data and the practical application. To help customers expand their knowledge of rheology and better utilize some of the advanced features of our instruments, we offer classes and seminars throughout the year. Course schedules and locations can be found on our website.

## Professional after-sales service

Rheometers are high-precision measuring instruments. We therefore recommend regular adjustment checks and maintenance, and offer maintenance contracts. Our worldwide after-sales service is carried out by qualified engineers who undergo regular and systematic training at our headquarters.

## Our international sales network

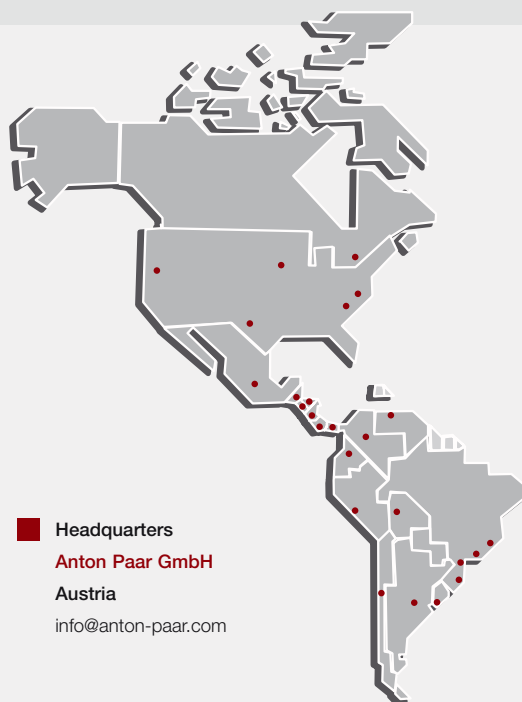

■ Headquarters  
Anton Paar GmbH  
Austria  
info@anton-paar.com

■ Countries with sales representatives

■ Direct sales via Anton Paar GmbH

● Exact location of sales representative



Photos: Croce & Wir



## Anton Paar

**Anton Paar** GmbH  
Anton-Paar-Str. 20  
A-8054 Graz  
Austria - Europe  
Tel.: +43 (0)316 257-0  
Fax: +43 (0)316 257 257  
E-mail: [info@anton-paar.com](mailto:info@anton-paar.com)  
Web: [www.anton-paar.com](http://www.anton-paar.com)



### International Product Management:

**Anton Paar** Germany GmbH  
Helmuth-Hirth-Str. 6  
D-73760 Ostfildern  
Germany - Europe  
Tel.: +49 (0)711 72091-0  
Fax: +49 (0)711 72091-630  
E-mail: [info.de@anton-paar.com](mailto:info.de@anton-paar.com)  
Web: [www.anton-paar.com](http://www.anton-paar.com)

### Instruments for:

Density and concentration measurement

Rheometry and viscometry

Sample preparation

Colloid science

Microhardness testing

X-ray structure analysis

CO<sub>2</sub> measurement

High-precision temperature measurement

Specifications  
subject to change  
without notice

09/04 C22IP01-B