

Service Guide

IntelliVue Patient Monitor MP2/X2

Patient Monitoring

Part Number M3002-9301B
4535 641 12541



PHILIPS

Contents

1 Introduction	9
Who Should Use This Guide	9
How to Use This Guide	9
Responsibility of the Manufacturer	10
Passwords	10
Warnings and Cautions	11
2 Theory of Operation	13
Monitor Theory of Operation	13
System Boundaries	14
Hardware Building Blocks	15
Data Flow	19
How does the Support Tool Work with the Monitor	22
Monitor Software Block Diagram	22
Block Diagram Legend	23
3 Testing and Maintenance	27
Introduction	27
Terminology and Definitions	28
Recommended Frequency	29
When to Perform Tests	30
Testing Sequence	34
Visual Inspection	35
Before Each Use	35
After Each Service, Maintenance or Repair Event	35
Power On Test	35
Safety Tests	36
Warnings, Cautions, and Safety Precautions	37
Safety Test Procedures	38
System Test	62
What is a Medical Electrical System?	62
General Requirements for a System	62
System Example	63
System Installation Requirements	64
Required Protective Measures at System Installation	65
System Test Procedure	75
Preventive Maintenance Procedures	76
Noninvasive Blood Pressure Measurement Calibration	76
Performance Assurance Tests	76
Basic Performance Assurance Test	76

Full Performance Assurance Test	77
ECG/Resp Performance Test	77
ECG Sync Performance Test	78
SpO2 Performance Test	78
NBP PerformanceTest	79
Invasive Pressure Performance Test	81
Temperature Performance Test	82
M3014A Capnography Extension Performance Tests	82
Microstream CO2 Performance Test	85
Cardiac Output Performance Test	90
Power Loss Alarm Buzzer Performance Test (only if Multi-Port Nurse Call Connector Board is installed)	92
IntelliVue 802.11 Bedside Adapter Communication Test	92
IIT Communication Test	93
Short Range Radio (SRR) Performance Test	94
Reporting of Test Results	95
Carrying Out and Reporting Tests	95
Evaluation of Test Results	97
Other Regular Tests	98
Locking/Unlocking Touch Operation	98
Battery Handling, Maintenance and Good Practices	98
About the Battery	98
Checking the Battery Status	99
Battery Status on the Main Screen	100
Battery Status Window	101
Checking Battery Charge	103
Replacing a Battery	103
Optimizing Battery Performance	104
Battery Safety Information	108
After Installation, Testing or Repair	108

4 Troubleshooting 109

Introduction	109
How To Use This Section	109
Who Should Perform Repairs	109
Replacement Level Supported	110
Software Revision Check	110
Software Compatibility Matrix	110
Compatibilty with MMS	111
Compatibility with Information Center	111
Obtaining Replacement Parts	111
Troubleshooting Guide	112
Checks for Obvious Problems	112
Checks Before Opening the Instrument	112
Troubleshooting Tables	114

Status Log	130
List of Error Codes	131
Troubleshooting with the Support Tool	131
Troubleshooting the Individual Measurements or Applications	131

5 Repair and Disassembly **133**

Who Should Perform Repairs	133
Tools required	133
Removing the Battery	134
Removing the Handle	134
Removing the Side Cover	135
Removing the Display/Exchanging the SRR Board	136
Reassembly of the Display	138
Removing the NBP Pump Assembly	138
Reassembling the NBP pump chassis	140
Exchanging the NBP Pump	142
Exchanging the NBP Airguide / IIT or WLAN Assembly	145
Reassembly Procedure	147
Exchanging the Loudspeaker	150
Reassembly Procedure	151
Removing the Power Board	152
Reassembly Procedure	154
Removing the ECG Sync Pulse Out Connector	155
Removing the Main Board	157
Removing the Rear Housing	158
Removing the Measurements	160
Exchanging the Main Housing	161
Exchanging the Silicon Pads	162
MMS Extensions - Exchanging the Top Cover, MSL Flex Cable and the Dual Link Bar	165
Exchange Procedures	166
Disassembly Procedures for the M3015A MMS Extension (HW Rev. A)	177
Removing the Front Cover	177
Refit Procedures for the MMS Extension	181
Smart Battery Charger LG1480 (M8043A)	183
Cleaning the Air Filter Mats	183
Replacing the Fan	183

6 Parts **187**

Exchange and Replacement Parts	189
MMS Extension Parts (M3012A, M3014A, M3015A and M3016A)	192
MMS Extension Part Numbers - Release Mechanisms	192
MMS Extension Part Numbers - Top Cover, Flex Cable and Link Bar	193
MMS Extension Part Numbers - Front Bezels	193
Exchange Parts List	195

Smart Battery Charger Part Numbers	197
7 Installation Instructions	199
Out-Of-Hospital Transport - Standards Compliance	199
Electromagnetic Interference (SRR)	201
Installation Checklist	201
Unpacking and Checking the Shipment	201
Initial Inspection	202
Claims for Damage	202
Repacking	202
Mounting the Monitor	203
Mounting the Monitor using the Anti-slip Pad	203
Mounting the Monitor using the MMS Mount and Mounting Clamp	205
Connecting the Monitor to AC Mains	209
Host Monitor as Power Source	209
External Power Supply M8023A(Standard with MP2, Optional with X2)	210
Checking Out the Monitor	211
Configuration Tasks	212
Checking Country-Specific Default Settings	212
Setting Altitude, Line Frequency, ECG Cable Colors and Height & Weight Units	213
Configuring the Equipment Label	213
Configuring IP Address, Subnet Mask and Default Gateway	214
Configuration Settings for CSCN Routed Bedside Monitors (RBM)	214
Configuring Routed Bedside Monitors Support	215
Setting the Date and Time	215
Handing Over the Monitor	216
Philips Clinical Network (Wired)	216
Philips IntelliVue Information Center	216
IntelliVue Instrument Telemetry (IIT)	217
Short Range Radio	218
Configuring SRR Channels	218
ECG Sync Pulse	221
MSL Cable Termination	222
8 Site Preparation	225
Introduction	225
Site Planning	225
Roles & Responsibilities	226
Monitor Site Requirements	228
Space Requirements	228
Environmental Requirements	228
Electrical and Safety Requirements (Customer or Philips)	229
Connecting Non-Medical Devices	230
Philips Medical LAN	230



<u>9 MP2/X2 Product Structure</u>	<u>231</u>
Upgrades	238
<u>10 Default Settings Appendix</u>	<u>241</u>
Country-Specific Default Settings	241
<u>11 Index</u>	<u>251</u>



Introduction

This Service Guide contains technical details for the IntelliVue MP2 Patient Monitor and the IntelliVue X2.

This guide provides a technical foundation to support effective troubleshooting and repair. It is not a comprehensive, in-depth explanation of the product architecture or technical implementation. It offers enough information on the functions and operations of the monitoring system so that engineers who repair them are better able to understand how it works.

Who Should Use This Guide

This guide is for biomedical engineers or technicians responsible for installing, troubleshooting, repairing, and maintaining Philips' patient monitoring systems.

How to Use This Guide

This guide is divided into eight sections. Navigate through the table of contents at the left of the screen to select the desired topic. Links to other relevant sections are also provided within the individual topics. In addition, scrolling through the topics with the page up and page down keys is also possible.

Responsibility of the Manufacturer

Philips only considers itself responsible for any effects on safety, EMC, reliability and performance of the equipment if:

- assembly operations, extensions, re-adjustments, modifications or repairs are carried out by persons authorized by Philips, and
- the electrical installation of the relevant room complies with national standards, and
- the instrument is used in accordance with the instructions for use.

To ensure safety and EMC, use only those Philips parts and accessories specified for use with the monitor. If non-Philips parts are used, Philips is not liable for any damage that these parts may cause to the equipment.

This document contains proprietary information which is protected by copyright. All Rights Reserved. Reproduction, adaptation, or translation without prior written permission is prohibited, except as allowed under the copyright laws.

Philips Medizin Systeme Böblingen GmbH

Hewlett-Packard Str. 2

71034 Böblingen, Germany

The information contained in this document is subject to change without notice.

Philips makes no warranty of any kind with regard to this material, including, but not limited to, the implied warranties or merchantability and fitness for a particular purpose.

Philips shall not be liable for errors contained herein or for incidental or consequential damages in connection with the furnishing, performance, or use of this material.

Passwords

In order to access different modes within the monitor a password may be required. The passwords are listed below.

Monitoring Mode: No password required

Configuration Mode: 71034

Demo Mode: 14432

Service Mode: 1345

Consult the configuration guide before making any changes to the monitor configuration.

Warnings and Cautions

In this guide:

- A **warning** alerts you to a potential serious outcome, adverse event or safety hazard. Failure to observe a warning may result in death or serious injury to the user or patient.
- A **caution** alerts you where special care is necessary for the safe and effective use of the product. Failure to observe a caution may result in minor or moderate personal injury or damage to the product or other property, and possibly in a remote risk of more serious injury.

Theory of Operation

Monitor Theory of Operation

The IntelliVue MP2/X2 Patient Monitor:

- displays real-time data
- alarms in the case of patient or equipment problems
- offers limited data storage and retrieval (trending)
- interfaces to the Philips Clinical Network and other equipment

The monitor can be configured with various different measurement and interface capabilities.

NOTE



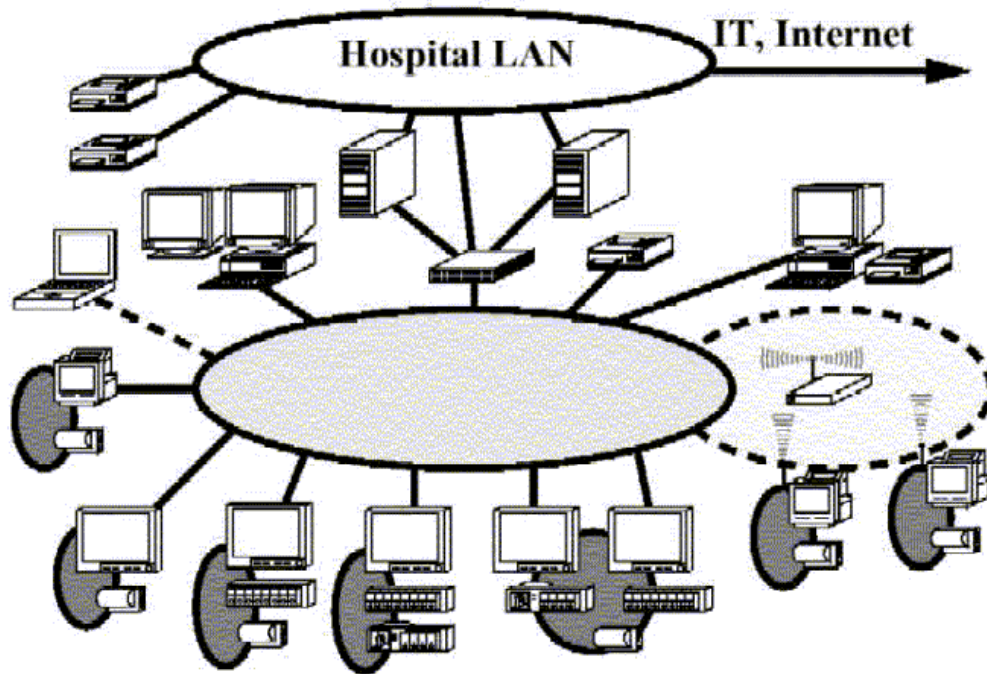

The following descriptions may vary depending on the monitor option purchased.

System Boundaries

The following diagram discusses specific boundaries within the overall system with respect to their openness and real-time requirements:

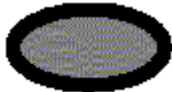

System Boundaries

	<p>Measurement connections Built-in measurement block</p>
	<p>Philips Clinical Network (wired LAN) connects multiple patient monitors, information centers, application servers; closed system, only Philips qualified products (tested and with regulatory approval) are connected, Philips is responsible for guaranteed real-time functionality and performance</p>
	<p>Philips Clinical Network (wireless) like Philips Clinical Network (wired) LAN, however due to current wireless technologies available it has reduced bandwidth, longer latencies, reduced functionality</p>
	<p>Hospital LAN, Internet Standard Network, not under Philips control, no guaranteed service, no real-time requirements</p>

Hardware Building Blocks

The following hardware building blocks make up the monitoring system:

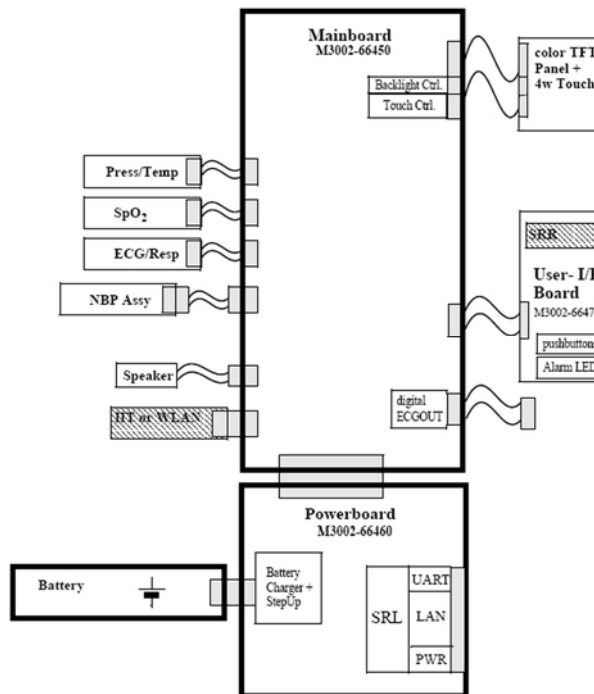

MP2/X2 Hardware Building Blocks

IntelliVue MP2

The MP2 monitor:

- integrates the display and processing unit into a single package
- uses a 3.5" color TFT display
- uses the Touchscreen as input device
- integrates the measurement block with optional parameter sets
- has an internal battery
- standalone patient monitor

IntelliVue X2

The IntelliVue X2:

- integrates the display and processing unit into a single package
- uses a 3.5" color TFT display
- uses the Touchscreen as input device
- integrates the measurement block with optional parameter sets
- has an internal battery
- can be used as a Multi-Measurement Module or as a standalone patient monitor

Optional Hardware

- An optional built-in wireless network interface (IntelliVue 802.11 Bedside Adapter or IntelliVue Instrument Telemetry) is supported. For further details regarding the wireless network please refer to the M3185A Philips Clinical Network documentation.
- Integrated Short Range Radio (SRR)

Power Distribution

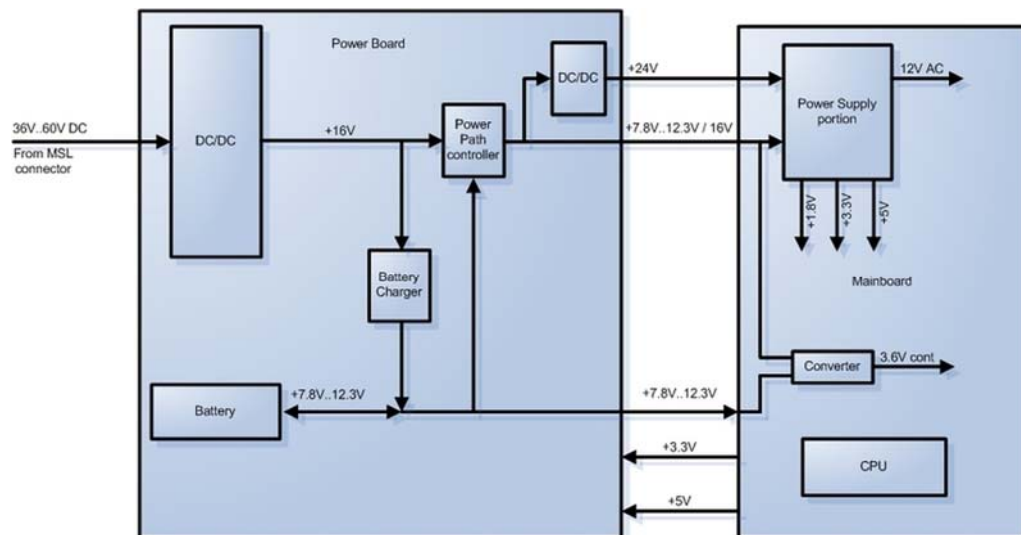

Power Distribution Architecture

The DC/DC converter transforms the DC power (36-60 V DC range) coming from the MSL plug into a 16 V DC source and isolates the monitoring system from the DC MSL.

The 16V DC is distributed via the Power Board to the battery charging circuit and to the main board.

The power is used to charge the battery and supply the monitoring system. As soon as the DC power source is disconnected, the battery starts and keeps the system powered (battery mode).

The main board contains power supply circuits, which convert the 16 V DC into several voltages supplying the particular components of the monitoring system.

The realtime clock and the buffered RAM is supplied with cont. 3.6 V DC power, provided either by the 16 V DC system power or by the battery power and converted to 3.6 V DC.

The CPU board has an MPC852 MHz processor in the patient monitor that provides a number of on-chip, configurable interfaces. An array of fast UARTS with configurable protocol options are implemented in an ASIC (along with other system functions such as independent watchdogs, video, etc.), providing interfacing capabilities to integrated measurements. The main board contains additional video hardware.

The CPU provides a LAN interface to connect to the Philips Clinical Network (Ethernet).

System Interfaces

The LAN interface on the Measurement Link (MSL) is used as the network interface.

Compatible Devices***M3012A, M3014A, M3015A, M3016A MMS Extensions*****NOTE**

The MMS Extensions are not supported if the IntelliVue MP2/X2 is powered from the internal battery. Although they can still be attached, they will not function in this case.

Data Flow

The following diagram shows how data is passed through the monitoring system. The individual stages of data flow are explained below.

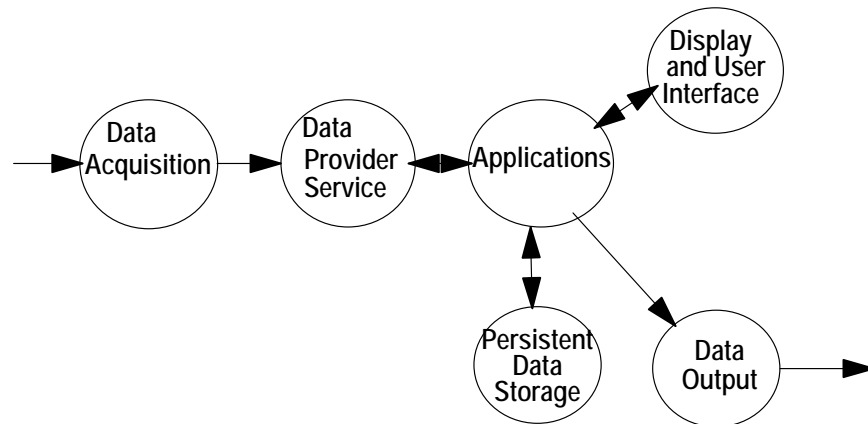

Data Flow

Data Acquisition

Monitoring data (for example patient measurement data in the form of waves, numerics and alerts) is acquired from a variety of sources:

- Measurement Block

The integrated measurements convert patient signals to digital data and apply measurement algorithms to analyze the signals.

- External measurement devices

Data can be also acquired from devices connected to the monitor. Software modules dedicated to such specific devices convert the data received from an external device to the format used internally.

- Server systems on the Philips Clinical Network

To enable networked applications, data can be acquired from server systems attached to the Philips Clinical Network, for example a Philips Information Center

Data Provider System Service

All data that is acquired from integrated measurements or external measurement devices is temporarily stored by a dedicated data provider system service. All monitor applications use this central service to access the data in a consistent and synchronized way rather than talking to the interfaces directly.

This service makes the applications independent of the actual type of data acquisition device.

The amount of data stored in the data provider system service varies for the different data types. For example several seconds of wave forms and the full set of current numerical values are temporarily stored in RAM.

Persistent Data Storage System Service

Some applications require storage of data over longer periods of time. They can use the persistent data storage system service. Dependent on the application requirements, this service can store data either in battery backed-up (buffered) memory or in flash memory. The buffered memory will lose its contents if the monitor is without power (not connected to mains) for an extended period of time. The flash memory does not lose its contents.

The trend application for example stores vital signs data in a combination of flash memory and buffered memory, while the system configuration information (profiles) is kept purely in flash memory.

Display and User Interface Service

Applications can use high level commands to display monitoring data or status and command windows on the internal LCD panel. These commands are interpreted by the display manager application. This application controls the dedicated video hardware which includes video memory and a special hardware in the ASIC.

User input is acquired from the touchscreen. The system software makes sure that the user input is directed to the application which has the operating focus.

Monitor Applications

The monitor applications provide additional system functionality over the basic measurement and monitoring capabilities. This includes for example trending, report generating, event storage or derived measurements.

In general, the monitor applications use the data provider system service to access the measurement data. Application interfaces to the other system services allow the application to visualize data, to store data over extended periods of time or to output data to other devices.

Internal LAN (Measurement Link)

The MP2/X2 communicates using an IEEE802.3 Ethernet LAN in the Measurement Link (MSL). This network is used to distribute data between the components, for example:

- Digitized patient signals including wave data, numerical data and status information (typically from the measurement server to a display unit)
- Control data representing user interactions (typically from the display unit to a measurement server)
- Shared data structures, for example representing patient demographical data and global configuration items

The internal LAN allows plug and play configuration of the monitoring system. The system automatically detects plugging or unplugging of measurement servers and configures the system accordingly.

The components on the internal LAN are time-synchronized to keep signal data consistent in the system. Dedicated hardware support for synchronization eliminates any latency of the network driver software.

The integrated LAN provides deterministic bandwidth allocation/reservation mechanisms so that the real-time characteristic of signal data and control data exchange is guaranteed. This applies to the data flow from the X2 to the host monitor (for example measurement signal data) and the data flow from the host monitor to an X2 (for example to feed data to a recorder module).

Philips Clinical Network

The monitoring system may be connected to the Philips Clinical Network, for example to provide central monitoring capabilities or other network services. This connection may be through a normal wired connection.

After configuration, the monitoring system sends the digitized patient signals including wave data, numerical data and status information onto the network. Control data representing user interactions can be exchanged between the monitoring system and a central station bi-directionally.

For plug and play operation, the monitoring system uses the standard BootP protocol to automatically acquire a network address.

How does the Support Tool Work with the Monitor

The support tool is a Windows application typically installed on the laptop of a customer engineer or a biomedical engineer working in the customer’s own service department.

The purpose of the support tool is to upgrade, configure and diagnose all monitoring components in the system over the network.

The service protocol developed for this purpose uses a raw access to the devices without the need for IP addresses etc. over a standard customer network installation, so that even defective devices can be upgraded as long as the few kBytes of initial boot code are working. The boot code itself can also be upgraded using the same protocol.

The tool allows access to internal service information and to serial numbers. It can be remote-controlled, for example via a dial-up connection from a response center, provided the proper infrastructure is in place.

For details see the Instructions for Use for the Support Tool.

Monitor Software Block Diagram

The figure below shows the functional block diagram for the monitoring system. A legend explaining terms and diagram elements follows. The information below varies depending on the purchased monitor options.

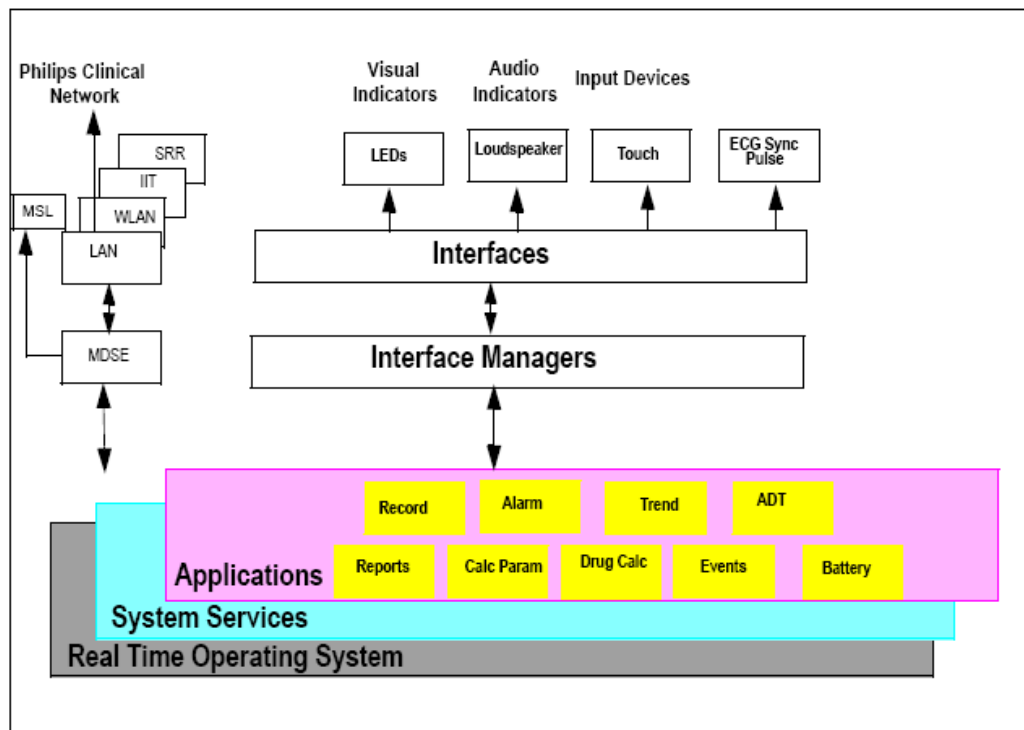

Functional Block Diagram

Block Diagram Legend

Functional Block	Description
Services	
Operating System	<p>The Operating System (OS) provides a layer of isolation between the specific hardware implementation and the application software. The OS performs system checks and allocates resources to ensure safe operation when the system is first started. This includes internal self-tests on several hardware modules and configuration checks for validity of configuration with the operating software. During normal operation, the OS continues to run checks on system integrity. If error conditions are detected the OS will halt monitoring operations and inform the operator about the error condition.</p>
System Services	<p>The System Services provide generic common system services. In particular: They use a real-time clock component to track time. They synchronize to network time sources and verify the accuracy of the system time information. They are also responsible for managing persistent user configuration data for all Measurement parameters and IntelliVue Patient Monitoring System software modules. User configuration data is stored in a non-volatile read/write storage device</p>
Applications	
Reports	<p>The Reports Service retrieves current and stored physiological data and status data to format reports for printing paper documentation. Examples of supported reports:</p> <ul style="list-style-type: none"> - Vital Signs Report - Graphical Trend Report - Event Review Report - Event Episode Report - ECG Report (12 Lead/Multi-Lead) - Test Report <p>The Reports service generates report data which can be printed on a central printer.</p>

Functional Block	Description
Alarm	The Alarm Service contains logic that prioritizes alarm conditions that are generated by IntelliVue Patient Monitoring System software modules. Visual alarm signals (messages) are displayed at the top of the IntelliVue Patient Monitoring System display and alarm sounds are generated by a loudspeaker. Alarm conditions may be generated when a physiological parameter exceeds preselected alarm limits or when a physiological parameter or any other software module reports an inoperative status (technical alarm, for example, the ECG leads may have fallen off the patient). The Alarm service manages the alarm inactivation states, for example suspension of alarms, silencing of alarms, and alarm reminder. Alarm signals may also be configured as latching (alarm signals are issued until they are acknowledged by the operator, even when the alarm condition is no longer true). The Alarm service controls the visual alarm signals (alarm lamps).
Trend	The Trend service stores the sample values of physiological data and status data with a resolution of 12 seconds, 1 minute or 5 minutes for a period of up to 48 hours. The data is kept in battery buffered read/write storage and flash memory devices to be preserved across power failures. The stored data is protected via consistency checks and checksums. When a new patient is admitted, the trend database erases all data of the previous patient.
ADT	The ADT (Admit/Discharge/Transmit) service maintains the patient demographics information. The operator may admit a new patient, discharge the old patient and enter or modify the patient demographics.
Calc Param	The Calc Param (Calculated Parameters) application performs calculations on physiological numerical values to derive calculated parameters like Temperature Difference.
Interface Managers	
MDSE	The MDSE (Medical Data Service Element) Interface Manager is responsible for the exchange of real-time data between the IntelliVue Patient Monitoring System display unit and the Measurement parameters and other devices attached to the network. MDSE establishes and maintains a data communication link between the devices. It provides configuration information about the remote device to applications in the local device and it allows the exchange of measurement data and status information between the devices.
Printer	<p>The Printer Interface Manager provides a high level interface to a printer. It provides means to:</p> <ul style="list-style-type: none"> - establish a connection to the printer - transfer data to the printer - get status of the printer - close connection to the printer <p>The Printer Interface Manager also supervises the connection to the printer and whether the printer accepts data (for example paper out). The Printer Interface Manager notifies the operator in such cases.</p>

Functional Block	Description
Display & Operator Interface	<p>The Display and Operator Interface Manager performs the following tasks:</p> <ul style="list-style-type: none"> - Screen presentation of real-time and stored physiological measurement data, alarm condition data and status information received from the MDSE interface manager, the Alarm service or other IntelliVue Patient Monitoring System modules - Screen presentation of operating controls (control windows) - Processing of operating control commands received from HIF Control interface. The module verifies and interprets the received commands and forwards them to other software modules of the IntelliVue Patient Monitoring System display unit or measurement parameters. - Sound generation (issues audible alarm signals and generates audible information signals, for example QRS and SpO2 tones, operator audible feedback)
Interfaces	
LAN	<p>The LAN interface implements the physical layer of IEEE 802.3. The LAN interface performs Manchester encoding/decoding, receive clock recovery, transmit pulse shaping, jabber, link integrity testing, reverse polarity detection/correction, electrical isolation, and ESD protection. Electronically separated interfaces are used for communication to the Measurement parameters and to the network.</p>
Display Controller	<p>The Display Controller Interface consists of a video controller, video RAM and the controlling software. The Display Controller interface processes the high level display commands (character and graphic generation, wave drawing) and translates them into pixels, which are written into the video RAM where the video controller chip generates the video synchronization signals and the pixel stream for the Color LCD Display.</p>
HIF Control	<p>The HIF (Human Interface Control) interface scans the Human Interface devices for operator controls (Touch Screen), formats the collected data and sends it to the display and Operating Interface.</p>
Sync Out (ECG)	<p>A pulse signal is provided on the Sync Out connector to allow synchronisation with other medical devices.</p>
IIT	<p>The built-in IIT module allows operation of the MP2/X2 monitors within IntelliVue Instrument Telemetry Infrastructure.</p>
WLAN	<p>The built-in WLAN interface allows wireless operation of the X2/MP2 monitors with the IntelliVue 802.11 Bedside Adapter</p>
SRR	<p>The built-in SRR interface allows wireless communication of the MP2/X2 monitors with an IntelliVue Instrument Telemetry Transceiver.</p>
MSL	<p>All components of the monitoring system communicate using an IEEE802.3/Ethernet LAN in the Measurement Link (MSL). This network is used to distribute data between the components</p>

Testing and Maintenance

Introduction

This chapter provides a checklist of the testing and maintenance procedures to ensure the performance and safety of the monitor and the MMS Extensions. For testing of the host monitor and the Flexible Module Rack (FMS), see the Service Guide of the host monitor.

These tests must be performed only by qualified personnel certified by the responsible organization. Qualifications required are: training on the subject, knowledge, experience and acquaintance with the relevant technologies, standards and local regulations. The personnel assessing safety must be able to recognize possible consequences and risks arising from non-conforming equipment.

All recurring safety and performance assurance tests must be performed under equal environmental conditions to be comparable.

Testing of the MP2/X2 may be performed either on the MP2/X2 (with external power supply) directly or (for the X2) on the host monitor.

Preventive Maintenance refers specifically to the series of tests required to make sure the measurement results are accurate. The accuracy and performance procedures are designed to be completed as specified in the following sections or when readings are in question.

For detailed instructions on the maintenance and cleaning of the monitor and its accessories, see *Care and Cleaning*, *Using Batteries* and *Maintenance and Troubleshooting* in the monitor's *Instructions for Use*.

Terminology and Definitions

The following terms and definitions are used throughout this chapter and taken from the international standards IEC 60601-1, IEC 60601-1-1 and IEC 62353.

- **Medical System:** a medical electrical system is a combination of at least one medical electrical device and other electrical equipment, interconnected by functional connection or use of a multiple portable socket-outlet.
- **Patient Vicinity:** any area in which intentional or unintentional contact can occur between the patient and parts of the medical system or between the patient and other persons who have had contact with parts of the medical system. The patient vicinity is defined anywhere within 1.5m (5 feet) of the perimeter of the patient's bed and 2.5m (8.2 feet) from the floor.
- **Separation Device/Transformer:** a component or arrangement of components with input parts and output parts that, for safety reasons, prevent a transfer of unwanted voltage or current between parts of a medical system.
- **Multiple Portable Socket-Outlet:** a combination of two or more socket-outlets intended to be connected to or integrated with flexible cables or cords, which can easily be moved from one place to another while connected to the power mains.
- **Functional Connection:** an electrical connection for transfer of signals and/or power.
- **Tests:** Safety or Performance Assurance test procedures which may consist of several steps.

Recommended Frequency

Perform the procedures as indicated in the suggested testing timetable. These timetable recommendations do not supersede local requirements.

Table 1: Suggested Testing Timetable

Tests		Frequency	
Preventive Maintenance*	NBP Performance	Once every two years, or more often if specified by local laws.	
	Microstream CO ₂ Calibration	Once a year or after 4000 hours of continuous use and following any instrument repairs or the replacement of any instrument parts.	
Other Regular Tests	Visual Inspection	Before each use.	
	Power On Test		
Performance Assurance Tests	ECG/Resp Performance	Once every two years, or if you suspect the measurement is incorrect, except Mainstream CO ₂ Accuracy Check, Sidestream CO ₂ Accuracy Check and Flow Check - required once a year.	
	ECG Sync Pulse Performance		
	SpO ₂ Performance		
	NBP Performance		
	Invasive Pressure Performance		
	Temperature Accuracy		
	M3014A Capnography Extension Performance Tests		
	Microstream CO ₂ Performance Test		
	C.O. Performance Test		
Safety Tests	Visual	Visual Inspection	After each service event.
	Electrical	Protective Earth	Once every two years and after repairs where the power supply has been removed or replaced or the monitor has been damaged by impact.
		Equipment Leakage Current	
		Patient Leakage Current	
		System Test	Once every two years

*M3015A with the old hardware Rev. A (i.e. Serial No. DE020xxxxx) also require the CO₂ pump/CO₂ scrubber replacement procedure. This is required every three years or after 15000 operating hours.

When to Perform Tests

This table tells you when to perform specific tests. The corresponding test procedures are described in the following sections. **All tests listed below must be performed on the monitor itself and its host monitor.**

When to perform tests

Service Event (When performing...	Tests Required ...Complete these tests)
Installation	
Installation of a monitor in combination with a medical or non-medical device connected to the same multiple socket outlet.	Perform Visual Inspection, Power On and System Tests
Installation of monitor with IntelliVue Instrument Telemetry (IIT)	Perform Visual Inspection, Power On and IIT communication test
Installation of monitor with IntelliVue 802.11 Bedside Adapter	Perform Visual Inspection, Power On and IntelliVue 802.11 Bedside Adapter Communication Test
Installation of a monitor with Short Range Radio (SRR)	Perform Visual Inspection, Power On and SRR communication test
Installation of networked monitor (LAN)	Perform Visual Inspection and Power On Test
Preventive Maintenance	
Preventive Maintenance*	Perform preventive maintenance tests and procedures: <ul style="list-style-type: none"> - NBP calibration - Microstream CO2 calibration
Other Regular Tests and Tasks	
Visual Inspection	Perform Visual Inspection test block

Service Event (When performing...	Tests Required ...Complete these tests)
Power On Test	Perform Power On test block
Repairs	
Repairs where the monitor has been damaged by impact, liquid ingress, fire, short circuit or electrical surge.	Perform Visual Inspection, Power On, all Safety Tests and Full Performance Assurance Tests
Repairs where the MSL power board is removed or replaced	Perform Visual Inspection, Power On, all Safety Tests and Basic Performance Assurance Test
Repairs where the main board has been replaced.	Perform Visual Inspection, Power On, Basic Performance Assurance Test and NBP Accuracy Test and Calibration.
Repairs where the measurement block has been removed or replaced	Perform Visual Inspection, Power On, all Safety Tests and Basic Performance Assurance Test. If a certain parameter seems suspicious, perform Full Performance Assurance Test for this parameter.
Repairs of IntelliVue Instrument Telemetry (IIT) Module	Perform Visual Inspection, Power On Test Block and IIT communication test
Repairs of IntelliVue 802.11 Bedside Adapter	Perform Visual Inspection, Power On and IntelliVue 802.11 Bedside Adapter Communication Test
Repairs of Short Range Radio (SRR) Interface	Perform Visual Inspection, Power On and SRR Communication Test
Repairs where the rear housing has been removed or replaced.	Perform Visual Inspection, Power On, all Safety Tests and Basic Performance Assurance Test.
Repairs where the NBP pump has been replaced	Perform Visual Inspection, Power On, all Safety Tests, Basic Performance Assurance Test and NBP Performance Test and Calibration
Repairs of the M3015A MMS Extension	Perform Visual Inspection, Power On, all Safety Tests, Basic Performance Assurance Test

Service Event (When performing...	Tests Required ...Complete these tests)
All other IntelliVue Monitoring System repairs (except when MSL power board is removed)	Perform Visual Inspection, Power On Test and Basic Performance Assurance Test
Performance Assurance	
Basic Performance Assurance	Perform basic performance assurance tests for the respective monitoring system component.
Full Performance Assurance	Perform all accuracy and performance test procedures listed in the following sections. If a particular measurement is in question, perform the measurement performance test only.
Upgrades	
Software Upgrades	Perform Visual Inspection, Power On Test and Basic Performance Assurance Test unless otherwise specified in the Upgrade Installation Notes shipped with the upgrade.
Hardware Upgrades	Perform Visual Inspection, Power On Test and Basic Performance Assurance Test unless otherwise specified in the Upgrade Installation Notes shipped with the upgrade.
Hardware Upgrades where IntelliVue Instrument Telemetry (IIT) is installed	Perform Visual Inspection, Power On Test, Basic Performance Assurance Test and IIT communication Test
Hardware Upgrades where IntelliVue 802.11 Bedside Adapter is installed	Perform Visual Inspection, Power On Test, Basic Performance Assurance Test and IntelliVue 802.11 Bedside Adapter Communication Test
Hardware Upgrades where Short Range Radio (SRR) is installed	Perform Visual Inspection, Power On Test, Basic Performance Assurance Test and SRR communication Test
Installation of Interfaces or Hardware Upgrades where the power supply or parameter boards need to be removed.	Perform Visual Inspection, Power On Test, Basic Performance Tests and all Safety Tests
Combining or Exchanging System Components	Perform the System Test for the respective system components

*M3015A with the old hardware Rev. A (i.e. Serial No. DE020xxxxx) also require the pump and scrubber replacement procedures.

NOTE

It is the responsibility of the facility operator or their designee to obtain reference values for recurring safety and system tests. These reference values are the results of the first test cycles after an installation. You may also purchase this service from Philips.

Testing Sequence

Summary of the recommended sequence of testing:

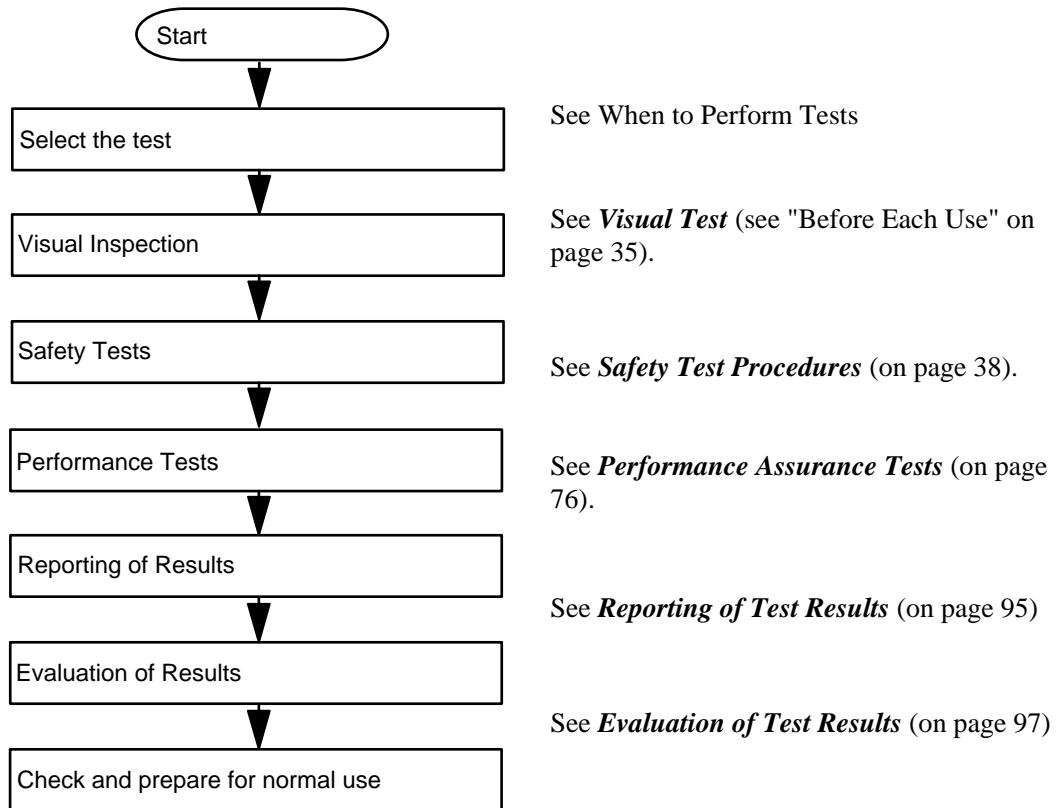

NOTE

If any single test fails, testing must be discontinued immediately and the device under test must be repaired or labeled as defective.

Visual Inspection

Before Each Use

Check all exterior housings for cracks and damage. Check the condition of all external cables, especially for splits or cracks and signs of twisting. If serious damage is evident, the cable should be replaced immediately. Check that all mountings are correctly installed and secure. Refer to the instructions that accompany the relevant mounting solution.

After Each Service, Maintenance or Repair Event

Ensure all fuses accessible from the outside comply with the manufacturer's specification.

Check:

- the integrity of mechanical parts, internally and externally.
- any damage or contamination, internally and externally
- that no loose parts or foreign bodies remain in the device after servicing or repair.
- the integrity of all relevant accessories.

Power On Test

1. Connect the monitoring system to mains and switch it on. This includes connected displays and MMS Extensions.
2. Make sure that all steps listed in the table *Initial Instrument Boot Phase* in the Troubleshooting section are completed successfully and that an ECG wave appears on the screen.

The expected test result is pass: the monitor boots up and displays an ECG wave. The wave might be a flat line if no simulator is attached.

Safety Tests

The following safety test needs to be performed on the monitoring system:

- applied part leakage current
- system test (if required)

Safety test requirements are set according to international standards, their national deviations and specific local requirements. The safety tests detailed in this Service Guide are derived from international standards but may not be sufficient to meet local requirements. We recommend that you file the results of safety tests. This may help to identify a problem early particularly if the test results deteriorate over a period of time.

Each individual piece of equipment of the monitoring system which has its own connection to mains or which can be connected or disconnected from mains without the use of a tool must be tested individually. The monitoring system as a whole must be tested according to the *System Test* (on page 61) procedure.

Accessories of the monitoring system which can affect the safety of the equipment under test or the results of the safety test must be included in the tests and documented.

Electrical safety tests for MP2/X2 can be performed either on the individual device (MP2 or X2) connected to the external power supply or on a connected host monitor (e.g. MP20-90). Note that if the electrical safety tests are performed with a host monitor the protective earth resistance and equipment leakage current come mainly from the host monitor. The earthing of MP2/X2 is for functional purposes and does not provide protection against electric shock. The protection against electric shock in this device is provided by double and/or reinforced insulation. The protective earth resistance and equipment leakage current measurements for MP2/X2 are optional.

Warnings, Cautions, and Safety Precautions







- These tests are well established procedures of detecting abnormalities that, if undetected, could result in danger to either the patient or the operator.
- Disconnect the device under test from the patient before performing safety tests.
- Disconnect the device under test from mains before performing safety tests. If this is not possible, ensure that the performance of these tests does not result in danger to the safety analyzer operator, patients or other individuals.
- Test equipment (for example, a *Safety Analyzer*) is required to perform the safety tests. Please refer to Annex C of IEC/EN 62353 for exact requirements for the measurement equipment and for measurement circuits for protective earth resistance and leakage currents. Refer to the documentation that accompanies the test equipment. Only certified technicians should perform safety testing.
- The consistent use of a *Safety Analyzer* as a routine step in closing a repair or upgrade is emphasized as a mandatory step to maintain user and patient safety. You can also use the *Safety Analyzer* as a troubleshooting tool to detect abnormalities of line voltage and grounding plus total current loads.
- During safety testing, mains voltage and electrical currents are applied to the device under test. Ensure that there are no open electrical conductive parts during the performance of these tests. Avoid that users, patients or other individuals come into contact with touch voltage.
- For Europe and Asia/Pacific, the monitor complies with:
IEC60601-1:1988 + A1:1991 + A2:1995 = EN60601-1:1990 +A1:1993 + A2:1995
IEC60601-1-1:2000
For USA, the monitor complies with:
UL60601-1
For Canada, CAN/CSA C22.2#601.1-M90
- Local regulations supersede the testing requirements listed in this chapter.
- If a non-medical electrical device is connected to a medical electrical device, the resulting medical electrical system must comply with IEC/EN 60601-1-1.
- Perform safety tests as described on the following pages.

Safety Test Procedures

Use the test procedures outlined here **only** for verifying safe installation or service of the product. The setups used for these tests and the acceptable ranges of values are derived from local and international standards but may not be equivalent. These tests are not a substitute for local safety testing where it is required for an installation or a service event. If using an approved safety tester, perform the tests in accordance with the information provided by the manufacturer of the tester and in accordance with your local regulations, for example IEC/EN 60601-1, UL60601-1 (US), IEC/EN 62353, and IEC/EN 60601-1-1. The safety tester should print results as detailed in this chapter, together with other data.

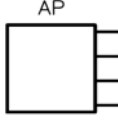
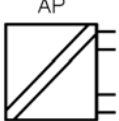
Please refer to Annex C of IEC/EN 62353 for requirements for the measurement equipment and for measurement circuits for protective earth resistance and leakage currents.

The following symbols are used in the diagrams illustrating the safety tests:

	Supply mains		Protective earth
L, N	Supply mains terminals	PE	Protective earth terminal
	Mains part		Applied part
	F-type applied part		Measuring device
	Resistance measuring device		Connection to accessible conductive parts
.....	Optional connection		

CAUTION

After each service, maintenance or repair event:

Ensure all fuses accessible from the outside comply with the manufacturer's specification.

Check:

- the integrity of mechanical parts, internally and externally.
 - any damage or contamination, internally and externally.
 - that no loose parts or foreign bodies remain in the device after servicing or repair.
 - the integrity of all relevant accessories.
-

Hints for Correct Performance of Safety Tests

- Perform a visual inspection on all detachable power cords used with the monitoring system and include these in all safety test procedures.
- Connection lines such as data lines or functional earth conductors may appear to act like protective earth connections. These may lead to incorrect measurements and need to be considered during testing. If necessary, unplug these connections.
- Position all cables and cords in such a manner that they do not influence the safety tests.
- Measurement of insulation resistance is not required.

Guideline for Performance of Safety Tests

Connect the detachable power cord of the device under test to the safety analyzer's test mains port. For testing the detachable power cord protective earth, use the setup provided with your safety analyzer. For testing the equipment leakage current and the applied part leakage current, connect all applied parts to the safety analyzer using the appropriate patient lead or adapter cable. For the ECG parameter all ten ECG-leads need to be connected to the safety analyzer. If necessary, use an adapter cable to connect all ten ECG-leads. If necessary, repeat the safety test procedure until all available applied parts have been tested. Refer to the documentation that accompanies the safety analyzer for further details on how to set up and perform the test.

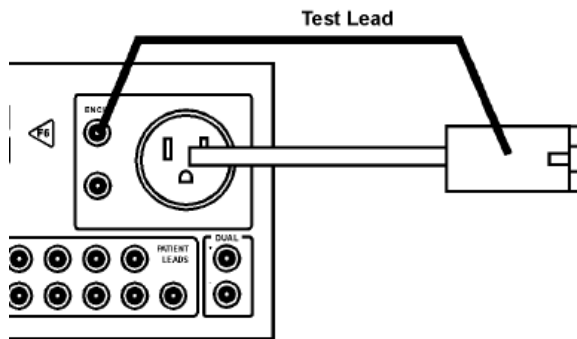

Detachable Power Cord Protective Earth Test - Setup Example

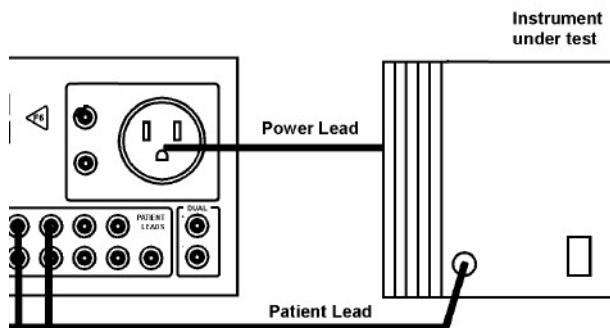

Equipment Leakage Current and Applied Part Current Test - Setup Example

NOTE

The above graphics resemble the Metron QA-90 setup and are protected by copyright. Copyright owned by Fluke (Metron).

Safety Test Adapter Cable - Schematics

The following graphics provide schematics of safety test (patient lead) adapter cables which can be used for electrical safety testing. These schematics can also be used as a guideline for making your own safety test adapter cables. Alternatively, other methods to make safety test adapter cables can be used, e.g. using a modified accessory cable.

NOTE

You may not need all of the cables displayed below for electrical safety testing of your respective monitor.

ECG:

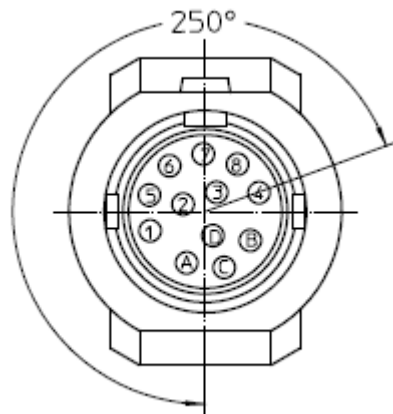

Wiring Schematic

PLUG 12-PIN
MALE

Conductor Coloring

Plug Banana



SpO2 (MP2/X2, MP5, M3001A & M1020B #A01, #A02, #A03):

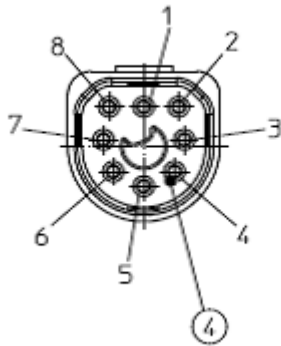

Wiring Schematic

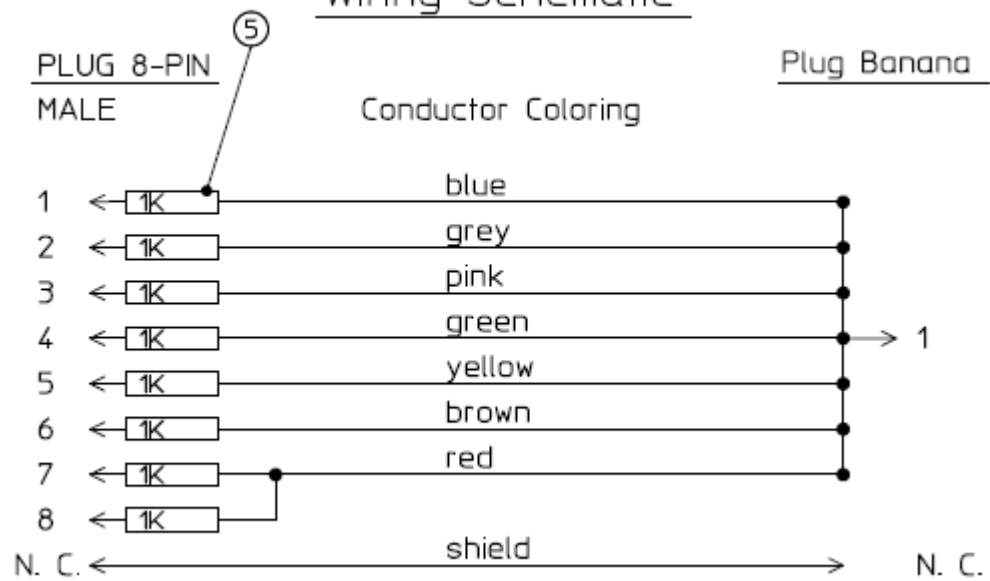

SpO2 (M1020A):

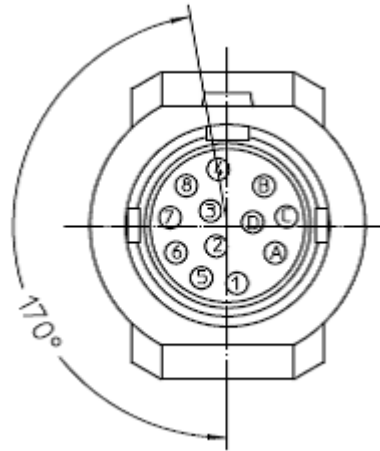

Wiring Schematic

PLUG 12-PIN
MALE

Conductor Coloring

Plug Banana

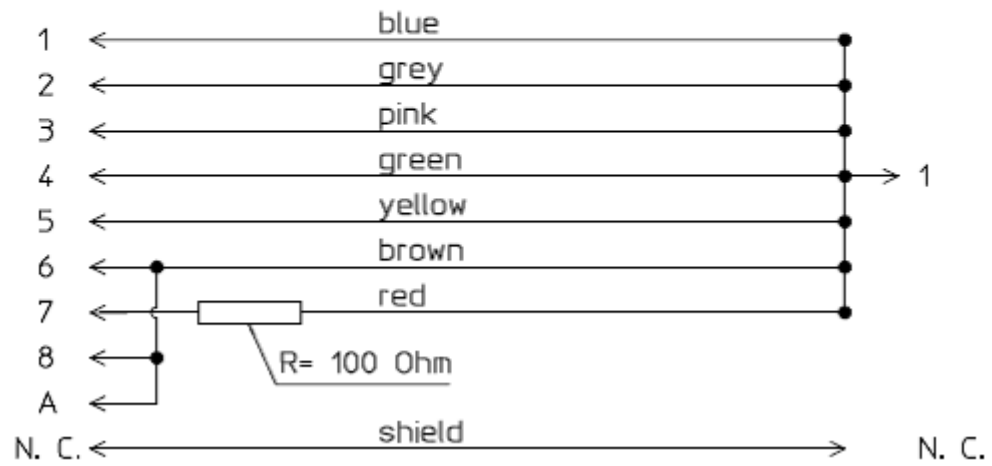

Invasive Pressure:

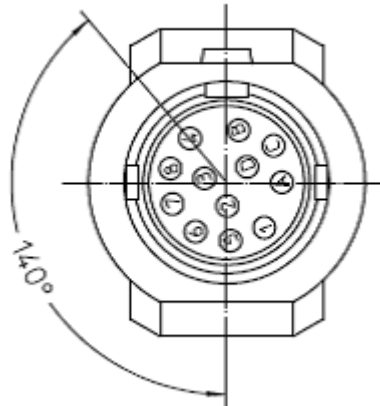

Wiring Schematic

PLUG 12-PIN
MALE

Conductor Coloring

Plug Banana



M1006B #C01:

Wiring Schematic



Temperature:

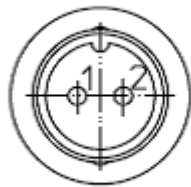

Wiring Schematic

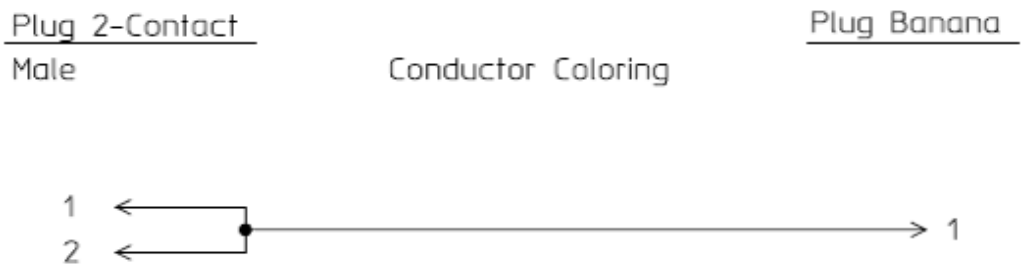

CO2 (MP5, M3014A):

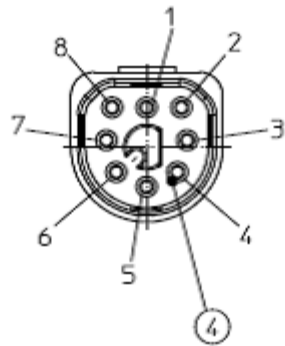

Wiring Schematic

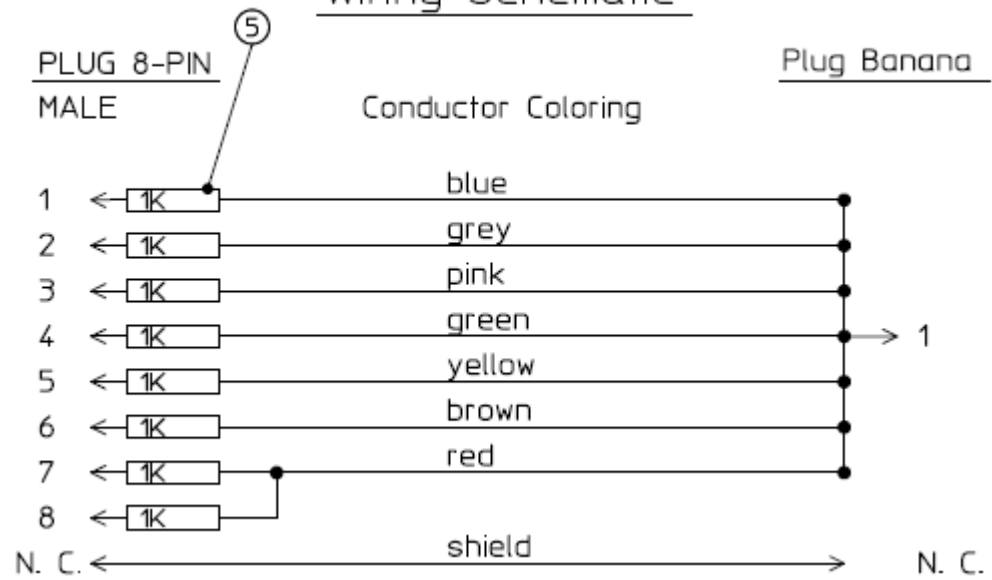

CO2 (M1016A, M3016A):

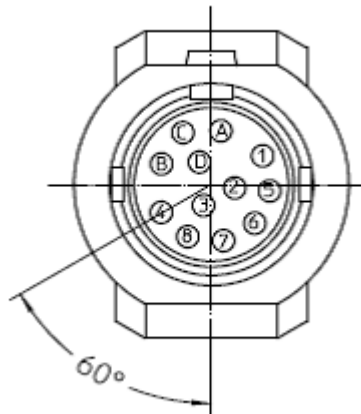

Wiring Schematic

PLUG 12-PIN
MALE

Plug Banana

Conductor Coloring

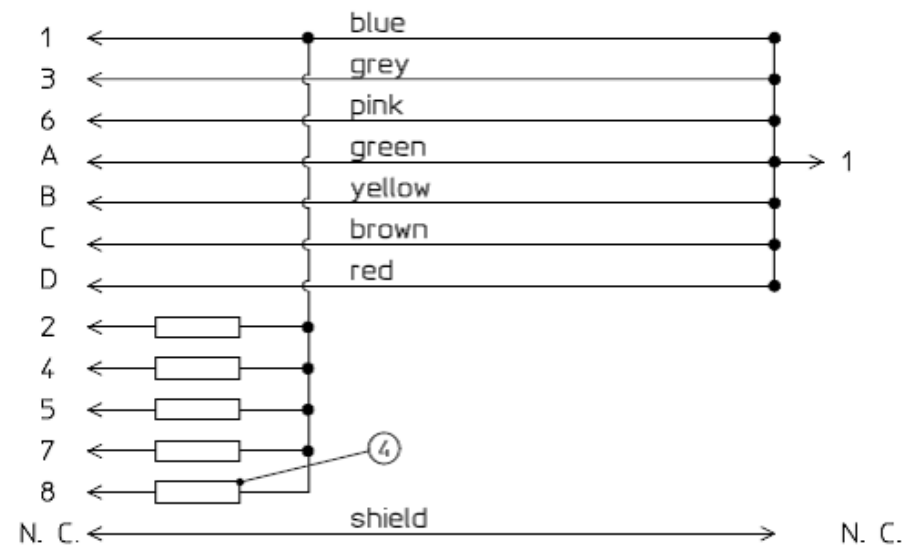

4 = all resistors 120 KOhm

Cardiac Output:

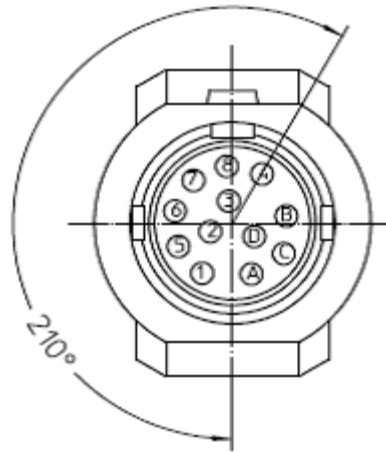

Wiring Schematic

PLUG 12-PIN

MALE

Conductor Coloring

Plug Banana

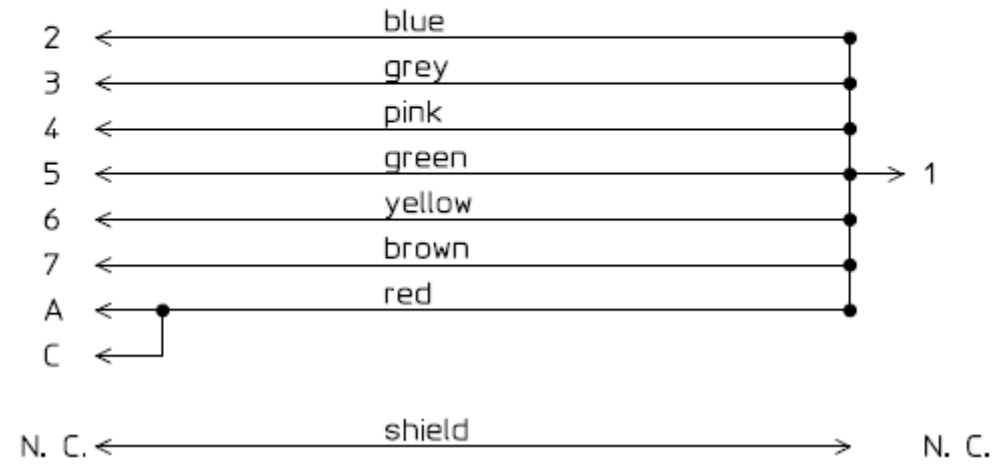

BIS:

Use Clamp Adapter Cable and M1034-61650 BIS sensor simulator.

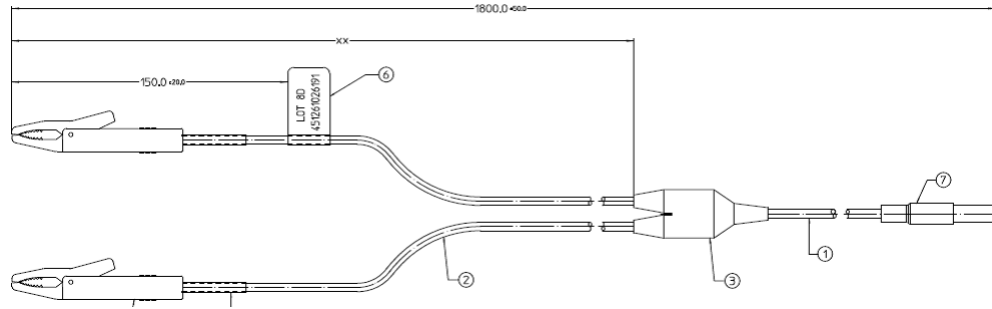

Wiring Schematic

Clamp

Divider

Plug Banana

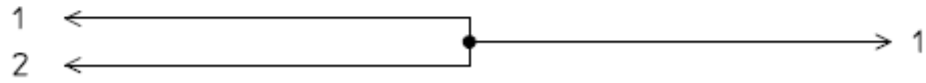

VueLink:

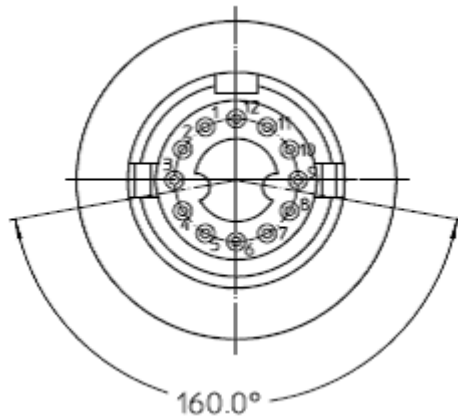

Wiring Schematic

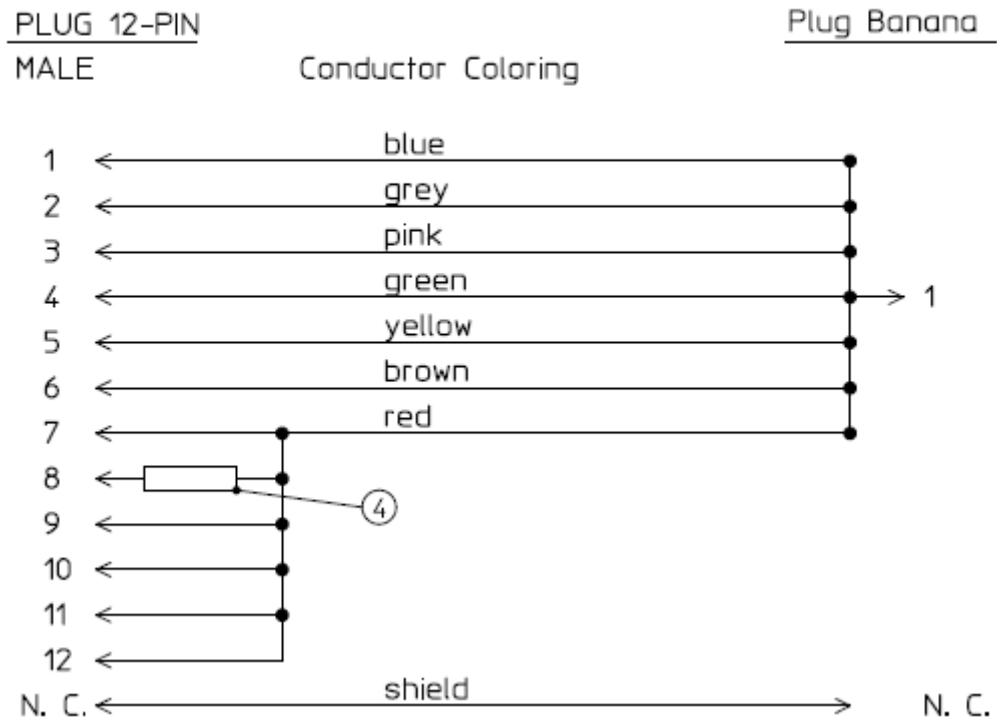

4 = 220 Ohm

IntelliBridge:

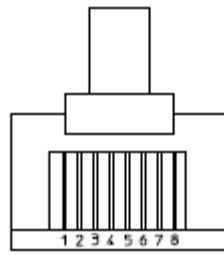

Wiring Schematic

Plug RJ-45

Plug Banana

Conductor Coloring



EEG:

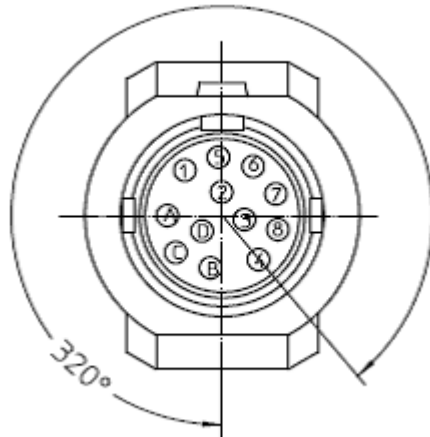

Wiring Schematic

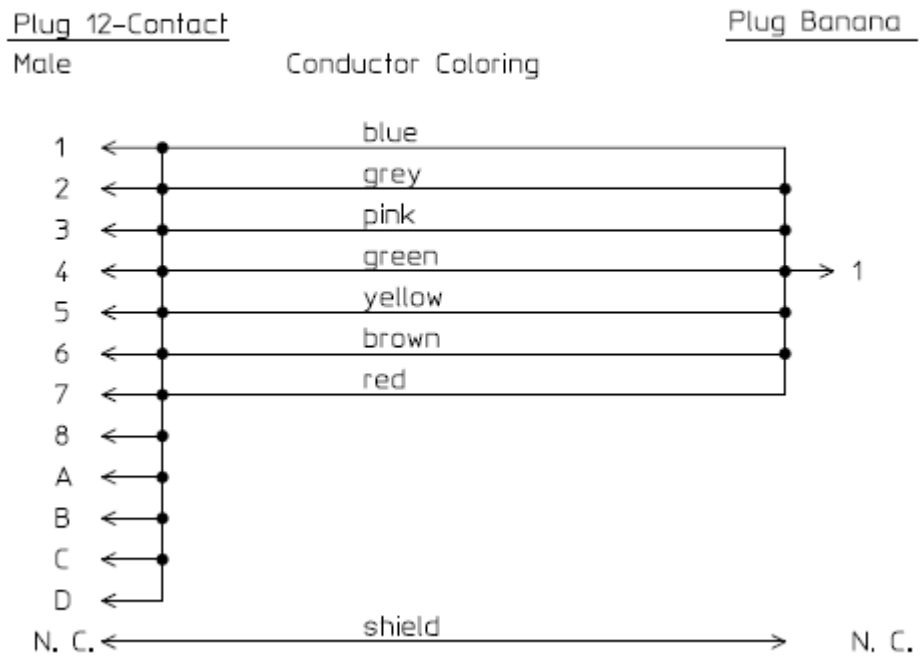

SvO2 (M1021A):

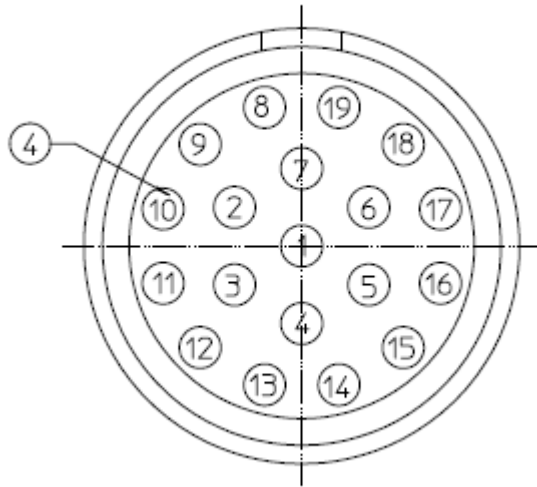

Wiring Schematic

Plug 19-Contact
Male

Conductor Coloring

Plug Banana

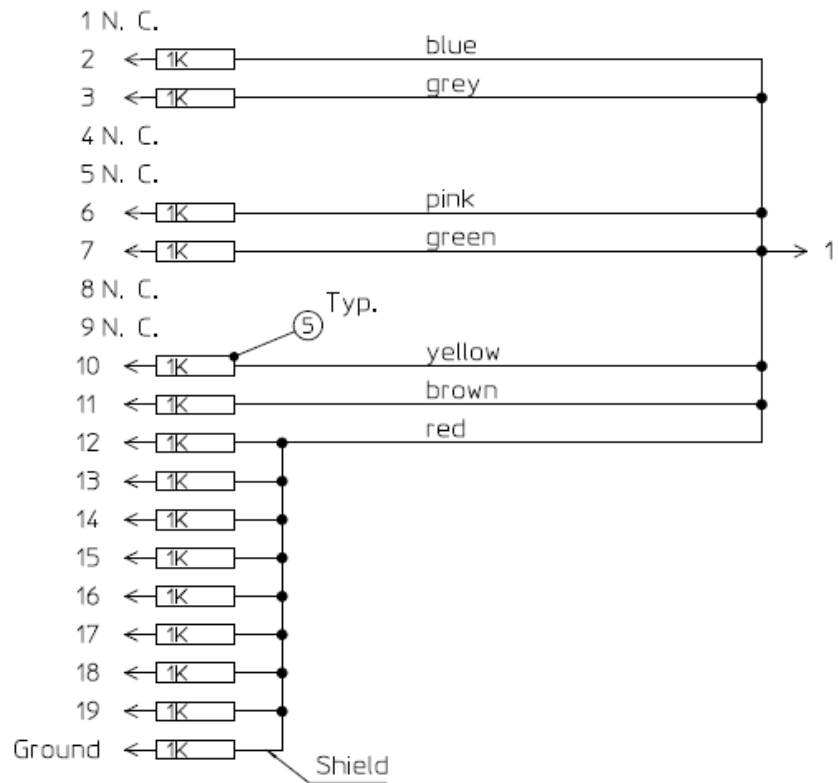

ScvO2 (M1011A):

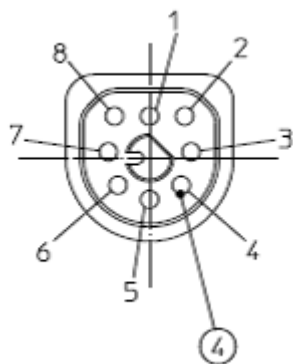

Wiring Schematic

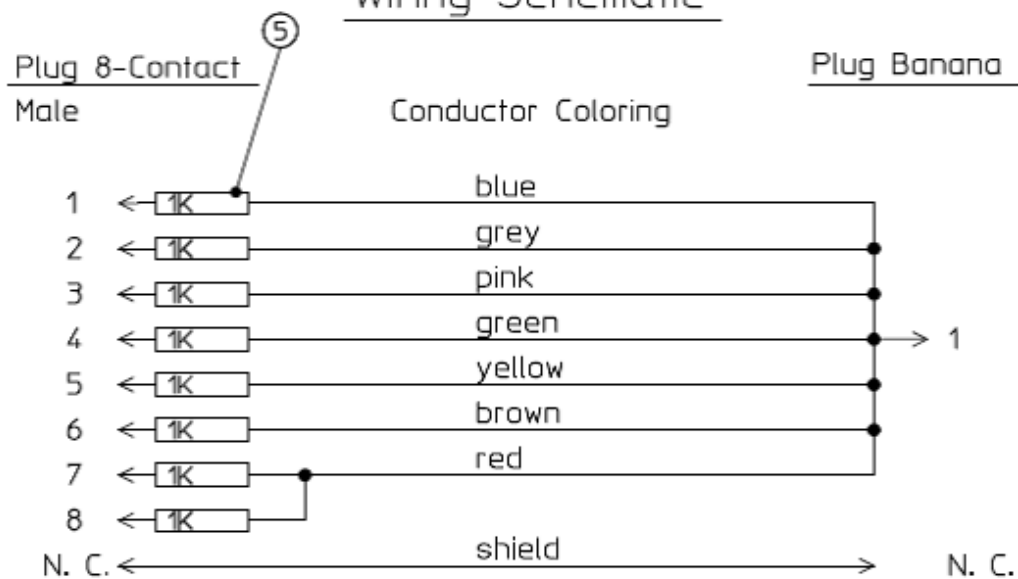

tcpO2/tcpCO2:

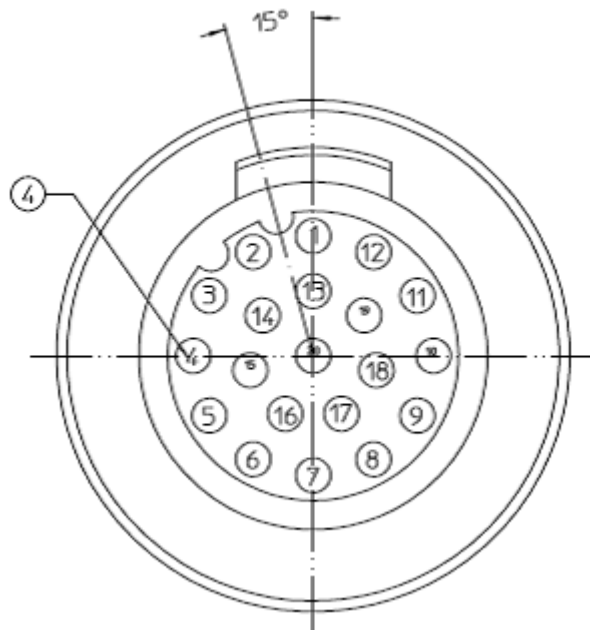

1
Wiring Schematic

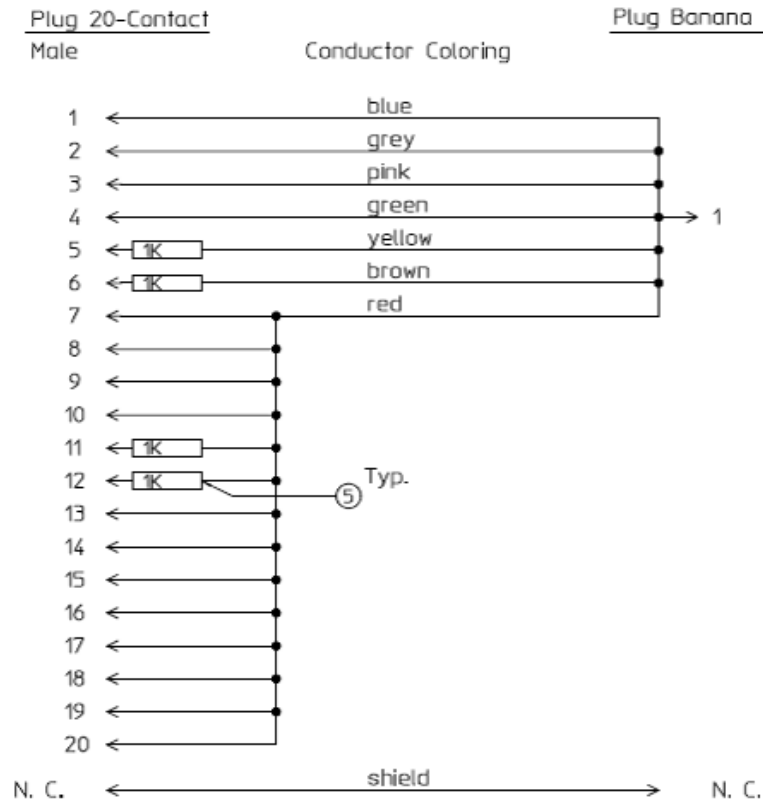

MP5 predictive Temperature:

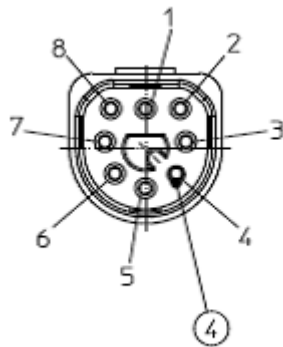

Wiring Schematic

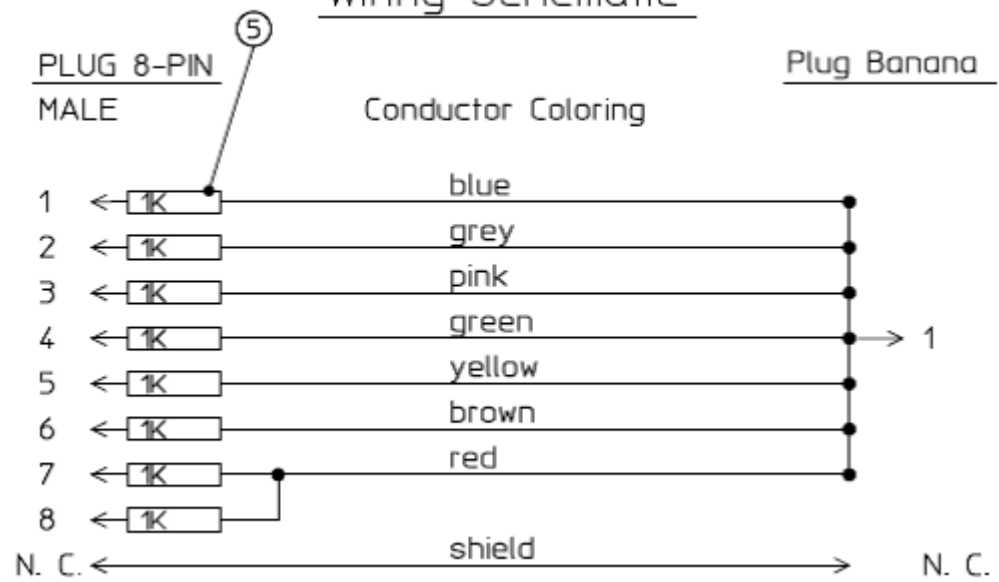

MP5 TAAP:

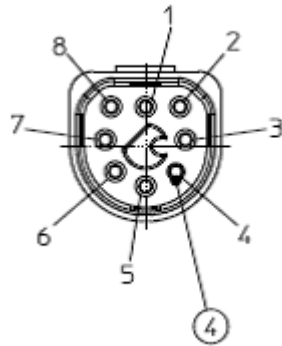

Wiring Schematic

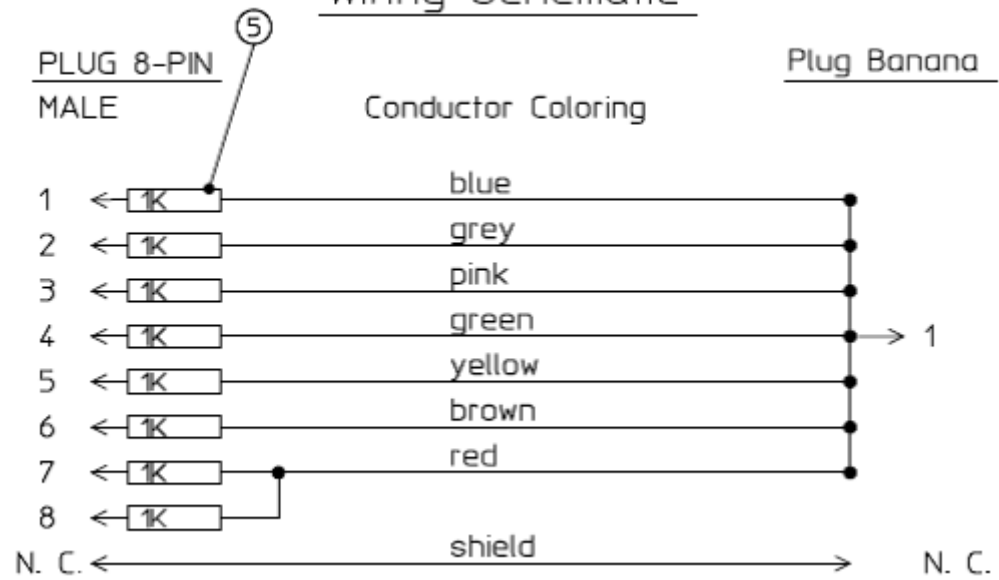

S(1): Detachable Power Cord Protective Earth Test (optional)

This test can be performed upon request by the customer.

Test to perform:

Use an Ohmmeter to measure the earth wire resistance of the detachable power cord.

This safety test is based on IEC/EN 60601-1, IEC/EN 62353, *UL2601-1 Ed. 2/UL60601-1:2003 and CSA 601.1-M90.*

Report the highest value (X1).

Test	Expected test results
Protective Earth Resistance Test	$X1 \leq 100\text{m}\Omega$

NOTE

- If the protective earth resistance test fails, testing must be discontinued immediately and the device under test must be repaired or labeled as defective.
- Flex the power cord during the protective earth resistance test to evaluate its integrity. If it does not pass the test, exchange the power cord.
- The functional earth conductor is required for EMC purposes. It has no protective function against electrical shock. The protection against electrical shock is provided by double and/or reinforced insulation.

S(2): Equipment Leakage Current Test - Normal Condition (optional)

This test can be performed upon request by the customer.

Test to perform:

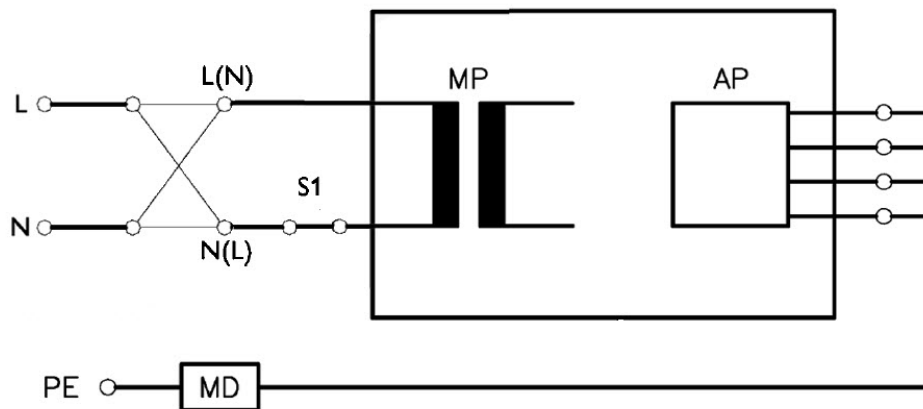

Measuring circuit for the measurement of Equipment Leakage Current - Direct method according to IEC/EN 62353.

This test measures the functional earth leakage current. It tests normal and reversed polarity. Perform the test with S1 closed (Normal Condition). There is no exposed metal part or functional earth connector which can be used to attach a test lead.

This safety test is based on IEC/EN 60601-1, IEC/EN 62353, *UL2601-1 Ed. 2/UL60601-1:2003 and CSA 601.1-M90.*

Report the highest value (X1).

Test	Expected test results
Equipment Leakage Current Test (Normal Condition - with mains cable)	$X1 \leq 100\mu A$

NOTE

All values for current and voltage are the root mean square (r.m.s.) values, unless otherwise stated.

S(3): Equipment Leakage Current Test - Single Fault Condition (optional)

This test can be performed upon request by the customer.

Test to perform:

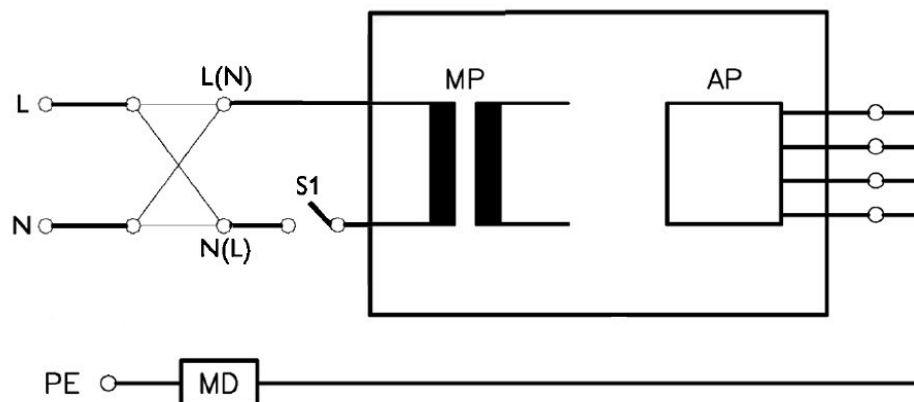

Measuring circuit for the measurement of Equipment Leakage Current - *Direct method according to IEC/EN 62353.*

This test measures the functional earth leakage current. It tests normal and reversed polarity. Perform the test with S1 open (Single Fault Condition). There is no exposed metal part or functional earth connector which can be used to attach a test lead.

This safety test is based on IEC/EN 60601-1, IEC/EN 62353, *UL2601-1 Ed. 2/UL60601-1:2003 and CSA 601.1-M90.*

Report the highest value (X2).

Test	Expected test results
Equipment Leakage Current Test (Single Fault Condition - with mains cable)	X2 \leq 300 μ A

NOTE

All values for current and voltage are the root mean square (r.m.s.) values, unless otherwise stated.

S(4): Applied Part Leakage Current - Mains on Applied Part

NOTE

During measurement of the Applied Part Leakage Current it is possible that the measured current can exceed the allowed limit (per IEC/EN 60601-1 or IEC/EN 62353).

This can occur when the safety tester is connected to the invasive blood pressure and temperature connectors at the same time during the applied leakage current measurement.

The connectors for the invasive blood pressure and temperature are independently functioning connectors.



Although there are individual connectors on the front end, internally those parameters use the same electrical insulation interface and are hardwired to each other. This results in an electrical short of those connectors during measurement if a test current is applied simultaneously. Therefore this should be avoided.

Due to the combined insulation interface, it is sufficient to connect to only one parameter interface (that is, Invasive Blood Pressure or Temperature) of the invasive blood pressure/temperature measurement block. This avoids a short and the potential of exceeding the limit for the current.

Test to perform:

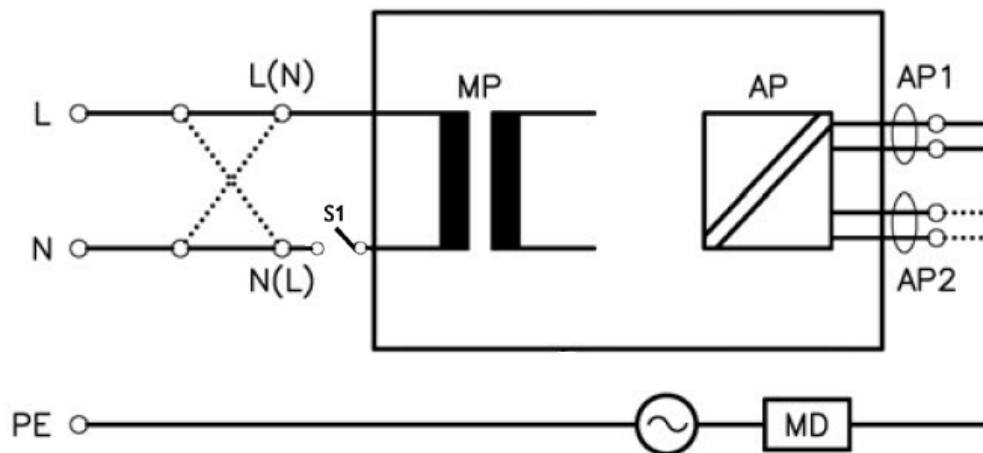

Measuring circuit for the measurement of Applied Part Leakage Current - Direct method according to IEC/EN 62353.

This test measures applied part leakage current from applied part to earth caused by external main voltage on the applied part. Each polarity combination possible shall be tested. This test is applicable for ECG measurement inputs. There is no exposed metal part or functional earth connector which can be used to attach a test lead.

This safety test is based on IEC/EN 60601-1, IEC/EN 62353, *UL2601-1 Ed. 2/UL60601-1:2003 and CSA 601.1-M90.*

For measurement limits and test voltage, refer to test block Safety (4), Test and Inspection Matrix.

Report the highest value. (X1).

Test	Expected test results
Applied Part Leakage Current Test (Single Fault Condition - mains on applied part)	X1 \leq 50 μ A

NOTE

All values for current and voltage are the root mean square (r.m.s.) values, unless otherwise stated.

System Test

After mounting and setting up a system, perform system safety tests according to IEC/EN 60601-1-1.

What is a Medical Electrical System?

A medical electrical system is a combination of at least one medical electrical piece of equipment and other electrical equipment, interconnected by functional connection or use of a multiple portable socket-outlet.

- Devices forming a medical electrical system must comply with IEC/EN 60601-1-1.
- Any electrical device such as IT equipment that is connected to the medical electrical equipment must comply with IEC/EN 60601-1-1 and be tested accordingly.

General Requirements for a System

After installation or subsequent modification, a system must comply with the requirements of the system standard IEC/EN 60601-1-1. Compliance is checked by inspection, testing or analysis, as specified in the IEC/EN 60601-1-1 or in this book.

Medical electrical equipment must comply with the requirements of the general standard IEC/EN 60601-1, its relevant particular standards and specific national deviations. Non-medical electrical equipment shall comply with IEC safety standards that are relevant to that equipment.

Relevant standards for some non-medical electrical equipment may have limits for equipment leakage currents higher than required by the standard IEC/EN 60601-1-1. These higher limits are acceptable only outside the patient environment. It is essential to reduce equipment leakage currents to values specified in IEC 60601-1 when non-medical electrical equipment is to be used within the patient environment.

System Example

This illustration shows a system where both the medical electrical equipment and the non-medical electrical equipment are situated at the patient's bedside.

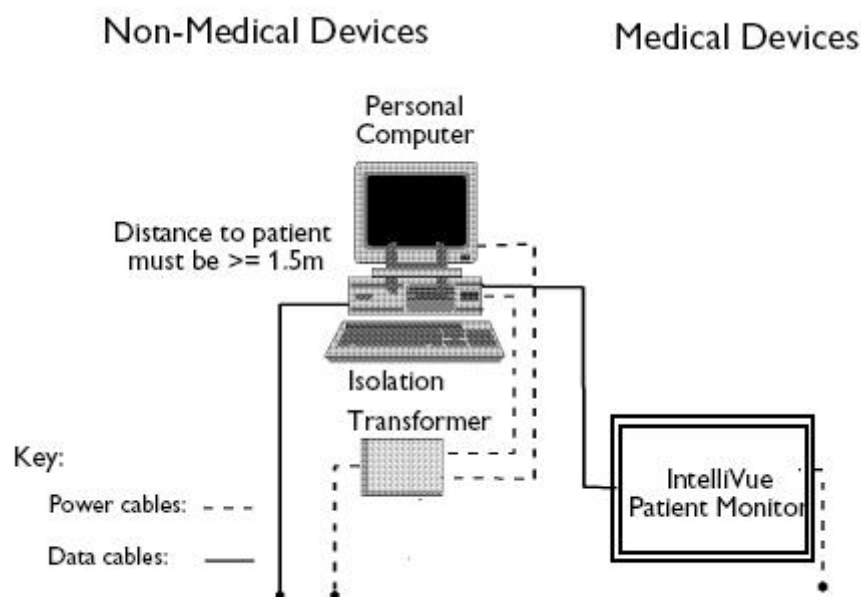

WARNING

- Do not use additional AC mains extension cords or multiple portable socket-outlets. If a multiple portable socket-outlet is used, the resulting system must be compliant with IEC/EN 60601-1-1. Do not place multiple socket-outlets on the floor. Do not exceed the maximum permitted load for multiple socket-outlets used with the system. Do not plug additional multiple socket outlets or extension cords into multiple socket outlets or extension cords used within the medical electrical system.
 - Do not connect any devices that are not supported as part of a system.
 - Do not use a device in the patient vicinity if it does not comply with IEC/EN 60601-1. The whole installation, including devices outside of the patient vicinity, must comply with IEC/EN 60601-1-1. Any non-medical device placed and operated in the patient's vicinity must be powered via a separating transformer (compliant with IEC/EN 60601-1-1) that ensures mechanical fixing of the power cords and covering of any unused power outlets.
-

System Installation Requirements

- Ensure that the the medical electrical system is installed in a way that the user achieves optimal use.
- Make sure the user is informed about the required cleaning, adjustment, sterilization and disinfection procedures listed in the Instructions for Use.
- The medical electrical system must be installed in such a way that the user is able to carry out the necessary cleaning, adjustment, sterilization and disinfection procedures listed in the Instructions for Use.
- Ensure that the medical electrical system is installed in a way that an interruption and restoration of power to any part of the medical electrical system does not result in a safety hazard.
- We recommend using fixed mains socket outlets to power the medical system or parts thereof. Avoid using multiple portable socket-outlets.
- Any multiple portable socket outlets used must be compliant with IEC 60884-1 and IEC 60601-1-1.
- Ensure that any part of the system connected to multiple portable socket-outlets is only removable with a tool, i.e. the multiple portable socket-outlet provides a locking mechanism to prevent power cords from being plugged or unplugged unintentionally. Otherwise, the multiple portable socket-outlet must be connected to a separation device. Multiple Socket Outlets used within the medical electrical system must only be used for powering medical electrical equipment which is part of the system.
- Ensure that any functional connections between parts of the medical electrical system are isolated by a separation device according to IEC 60601-1-1 to limit increased equipment leakage currents caused by current flow through the signal connections. This only works if the equipment leakage current of the respective medical electrical system parts is not exceeded under normal conditions.
- Avoid increase of equipment leakage currents when non-medical electrical equipment within the medical electrical system is used. This only works if the equipment leakage current of the respective medical electrical system parts is not exceeded under normal conditions. Use additional protective earth connection, separation device or additional non-conductive enclosures.
- Within the patient environment it is important to limit electrical potential differences between different parts of a system. If necessary, use potential equalization equipment (equipotential cable) or additional protective earth connections.
- Medical electrical equipment used in medical rooms must be connected to potential equalization equipment (equipotential cable) to avoid electrical potential differences. Check your local requirements for details.

Required Protective Measures at System Installation

For any IT equipment (IEC60950) operated in patient vicinity ensure that the equipment leakage current does not exceed the limits described in IEC 60601-1. Use a separation device to ensure compliance. After installation of IT equipment in patient vicinity, an enclosure leakage current test is required.

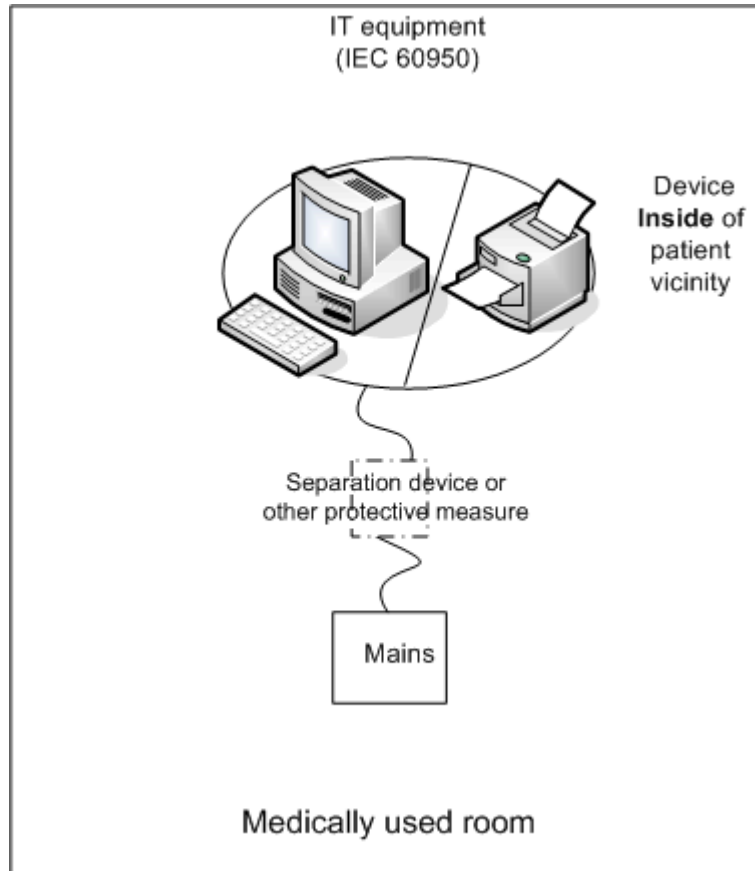

Case 1: Medical Device Combined with Medical Device

If you combine a medical device with another medical device (incl. Philips specified displays) to form a medical electrical system according to IEC60601-1-1, no additional protective measures are required. The medical electrical devices may be located in or outside the patient vicinity in a medically used room. This is valid as long as the medical devices are connected to separate mains outlets. No system test is required.

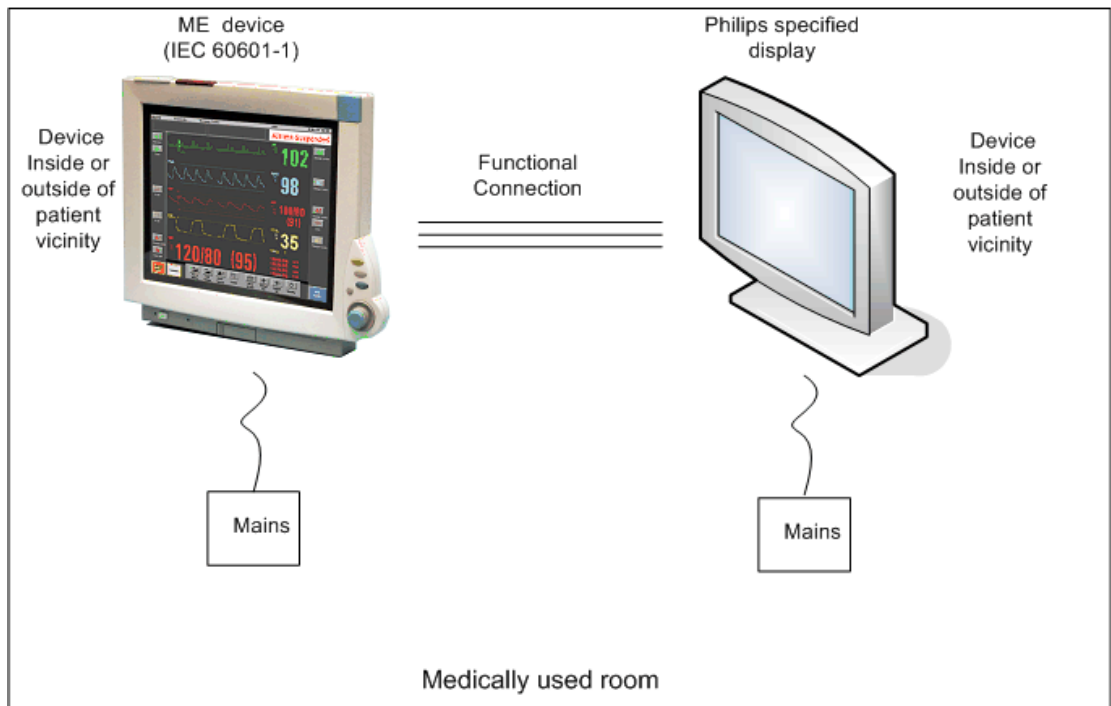
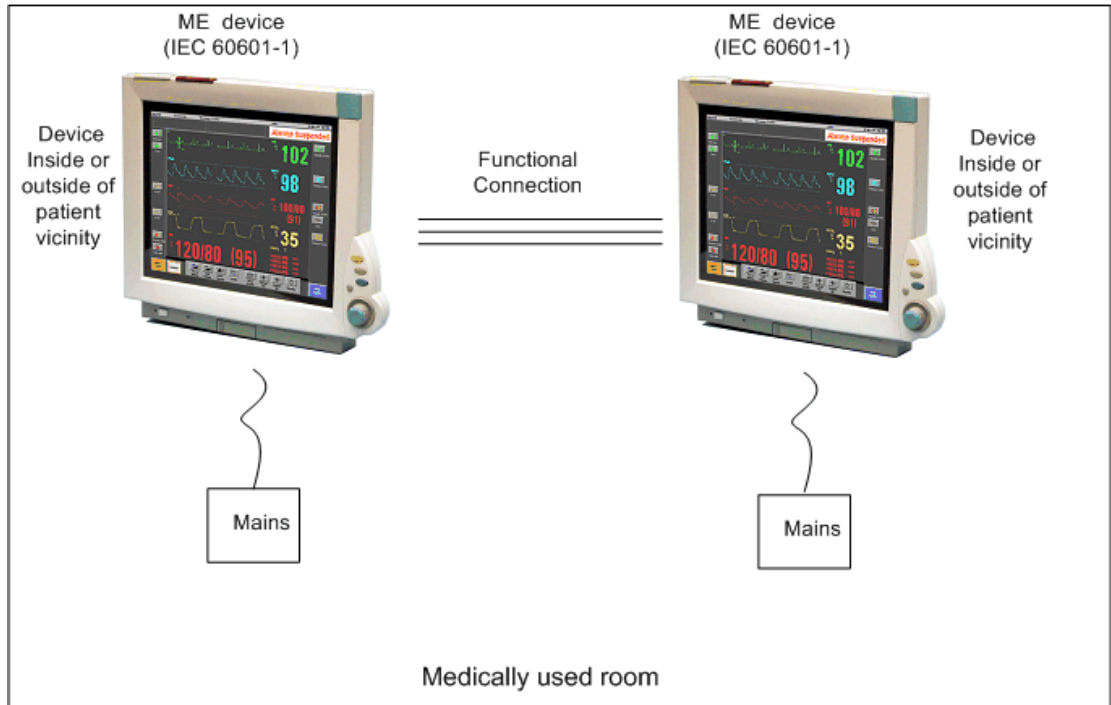

If the combined medical devices are connected to the same multiple portable socket outlet an enclosure leakage current test of the entire device combination on the multiple portable socket outlet is required to ensure that the resulting protective earth leakage current and equipment leakage current does not exceed the limits of IEC 60601-1. Avoid using multiple portable socket outlets. The medical electrical devices may be located in or outside the patient vicinity in a medically used room. If the limits are exceeded, additional protective measures are required, e.g. a separation device or the connection of each device to separate mains.

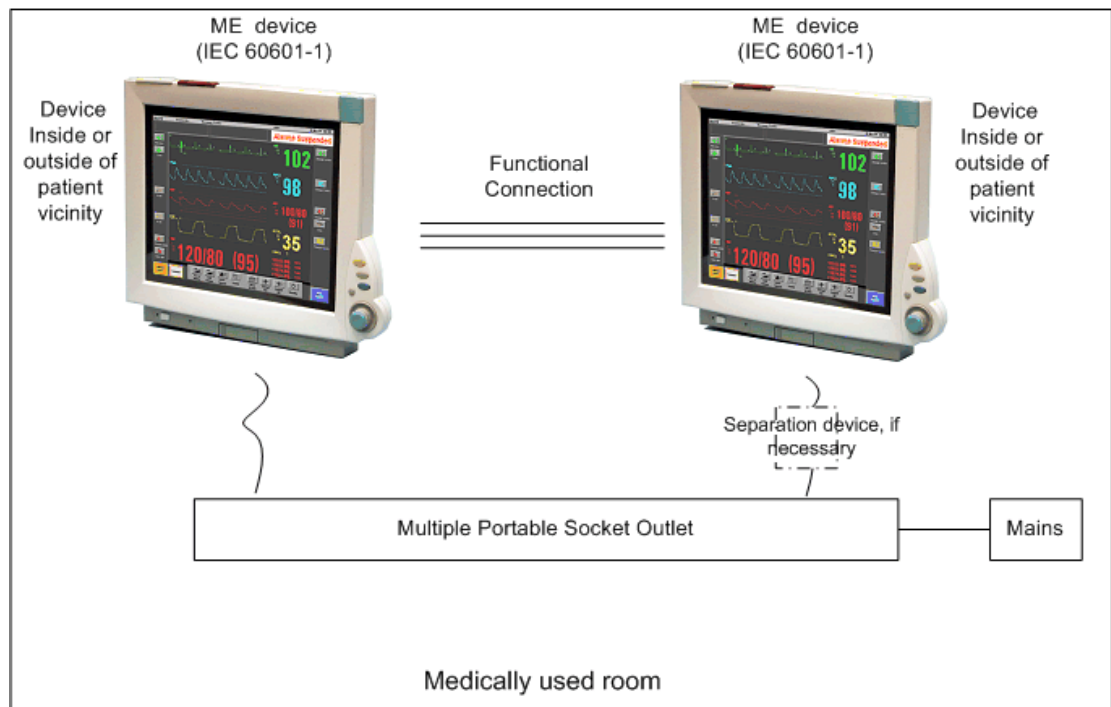

Case 2: Medical Device Combined with a Non-Medical Device

If you combine a medical device with a non-medical device to form a medical electrical system according to IEC60601-1-1, additional protective measures are required, e.g. usage of a separation device. The medical electrical devices or the IT equipment may be located in or outside the patient vicinity in a medically used room. After system installation incl. protective measures, a system test is required to ensure that the resulting equipment leakage current and applied part leakage current does not exceed the limits of IEC 60601-1-1.

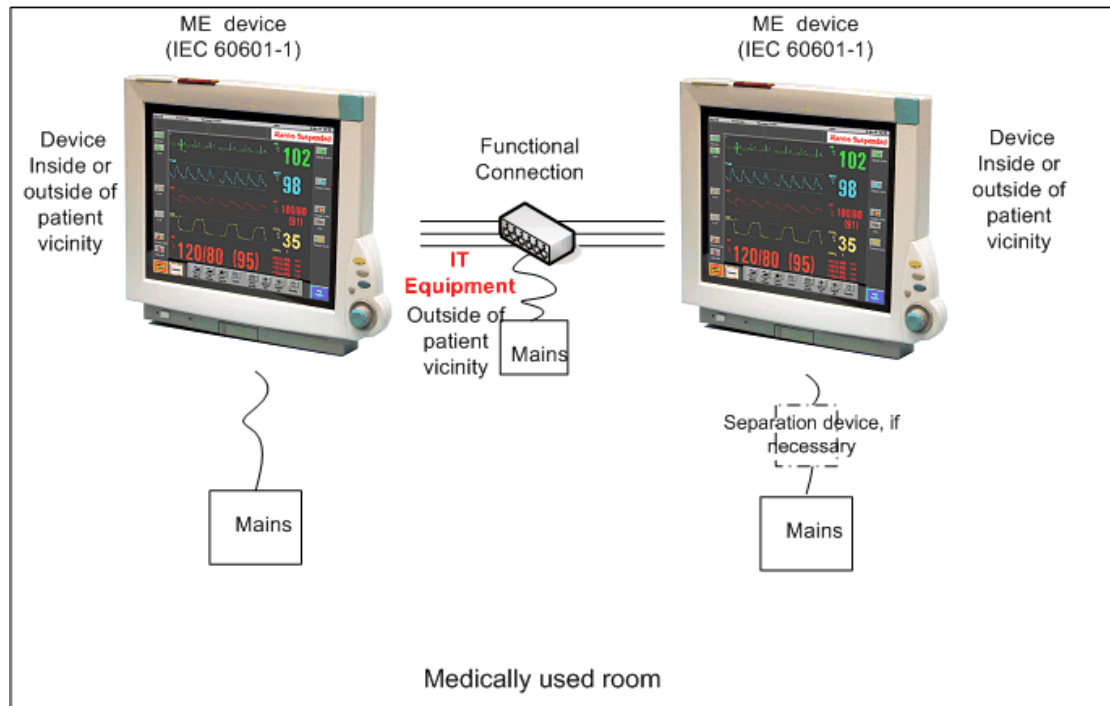

For any IT equipment (IEC60950) operated in patient vicinity ensure that the equipment leakage current does not exceed the limits described in IEC 60601-1. Use a separation device to ensure compliance. After installation of IT equipment in patient vicinity, an enclosure leakage current test is required.

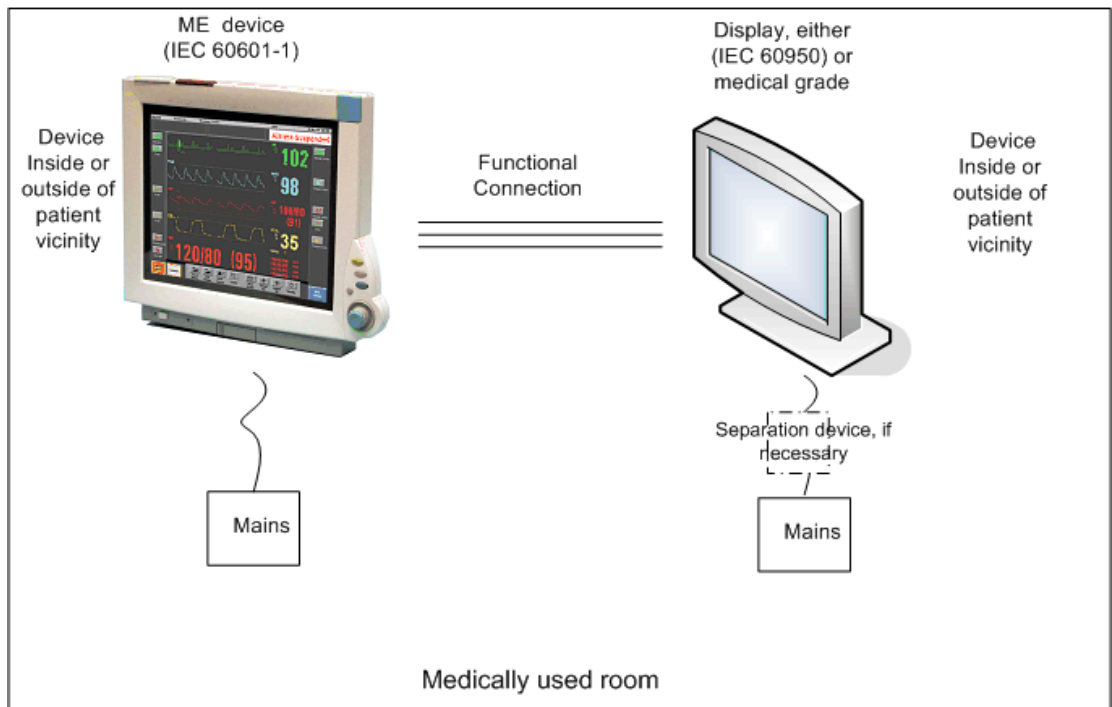
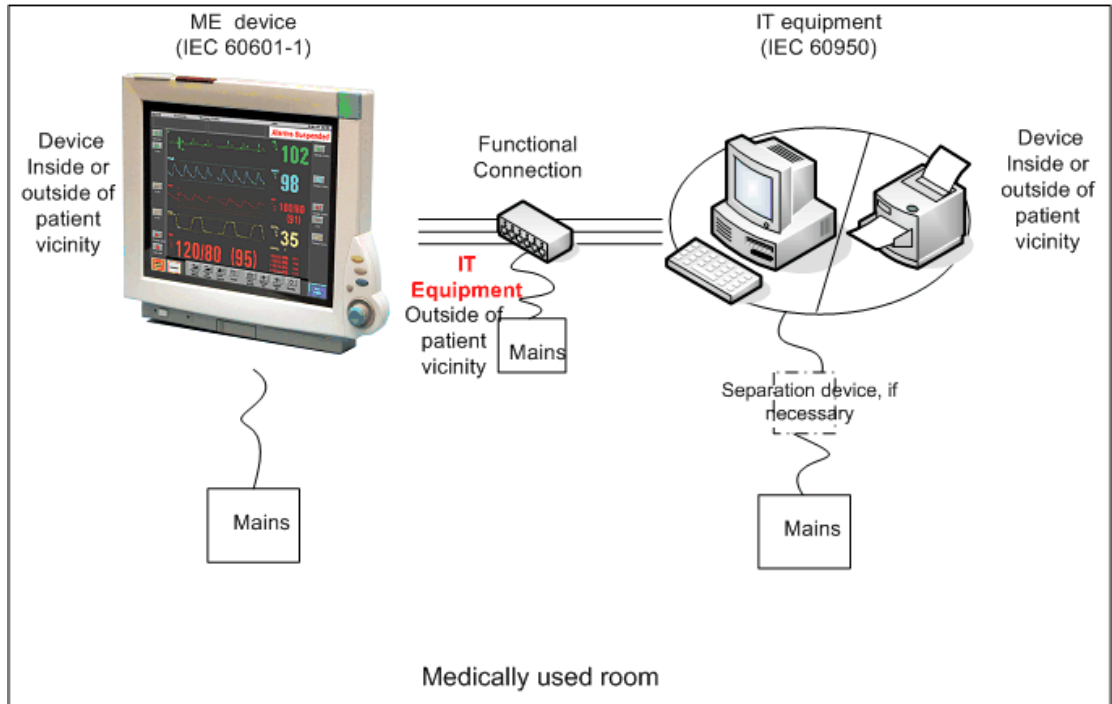

If the combined devices forming the medical electrical system are connected to the same multiple portable socket outlet, ensure that the resulting protective earth leakage current **and** equipment leakage current do not exceed the limits of IEC 60601-1-1. The medical electrical devices or IT equipment may be located in or outside the patient vicinity in a medically used room. Avoid using multiple portable socket outlets. If the limits of IEC 60601-1-1 are exceeded, additional protective measures are required, e.g. a separation device or the connection of each device to separate mains.

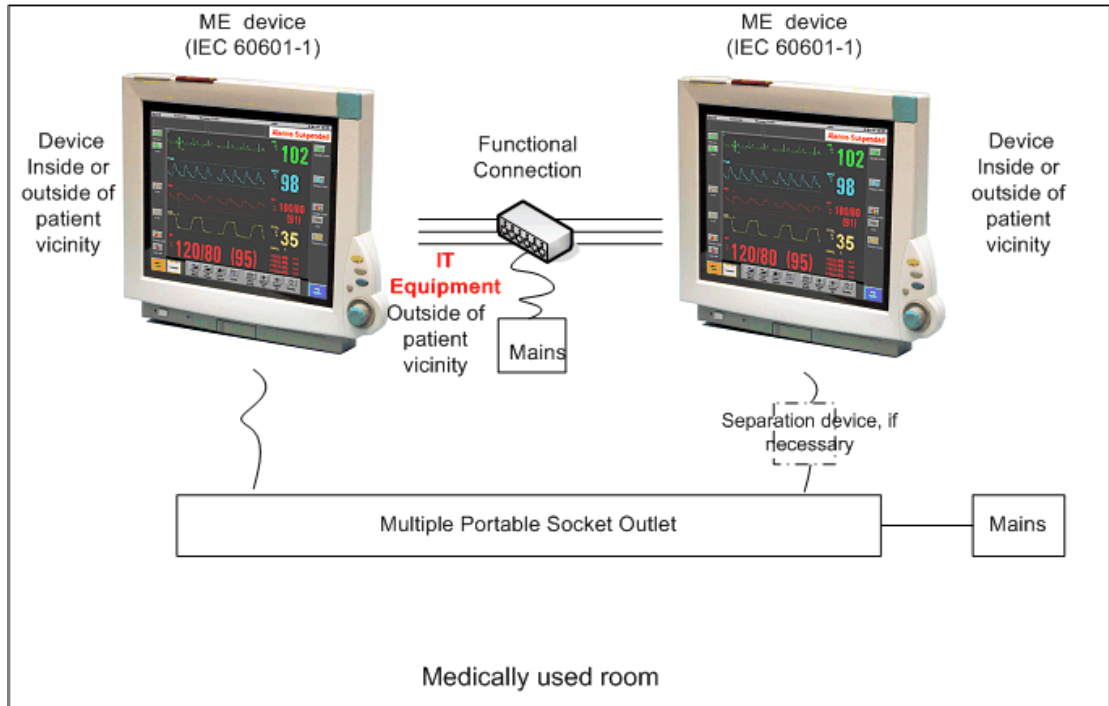

For any IT equipment (IEC60950) operated in patient vicinity ensure that the equipment leakage current does not exceed the limits described in IEC 60601-1. Use a separation device to ensure compliance. After installation of IT equipment in patient vicinity, an enclosure leakage current test is required.

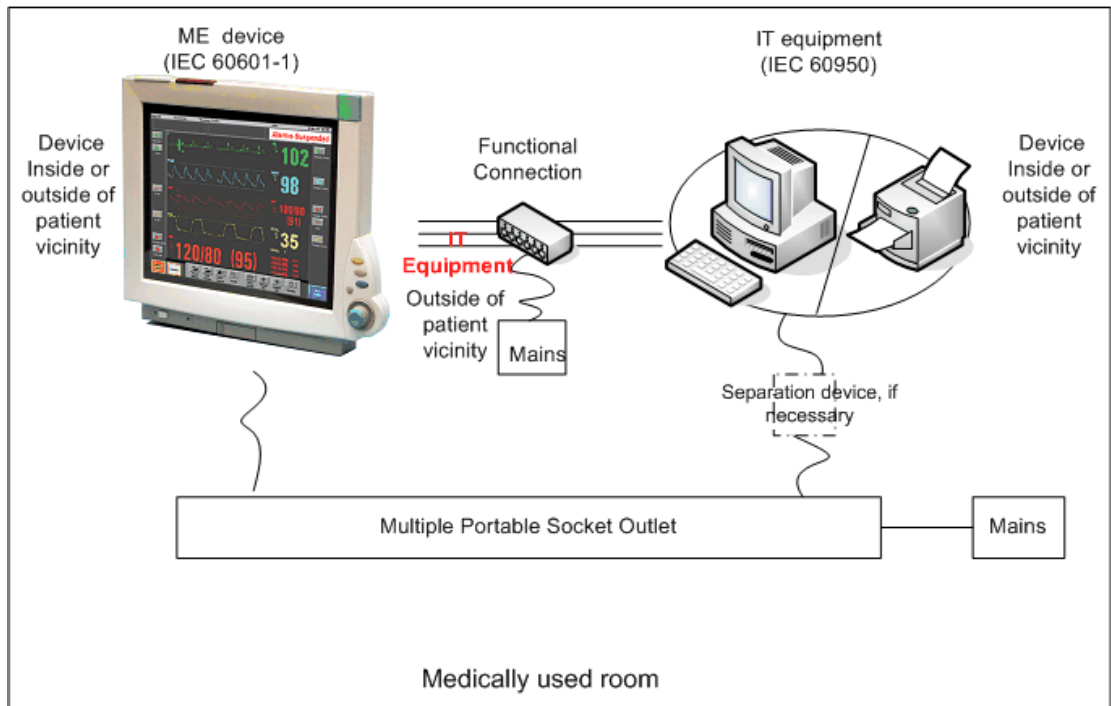

Case 3: Medical Device Combined with a Medical or Non-Medical Device with one Device in a Non-Medically-Used Room

If you combine a medical device with a medical or non-medical device to form a medical electrical system according to IEC60601-1-1 using a common protective earth connection and one of the devices is located in a non-medically used room, additional protective measures are required, e.g. usage of a separation device or additional protective earth connection. The medical electrical devices or IT equipment may be located in or outside the patient vicinity. After system installation incl. protective measures, a system test is required to ensure that the resulting equipment leakage current does not exceed the limits of IEC 60601-1-1.

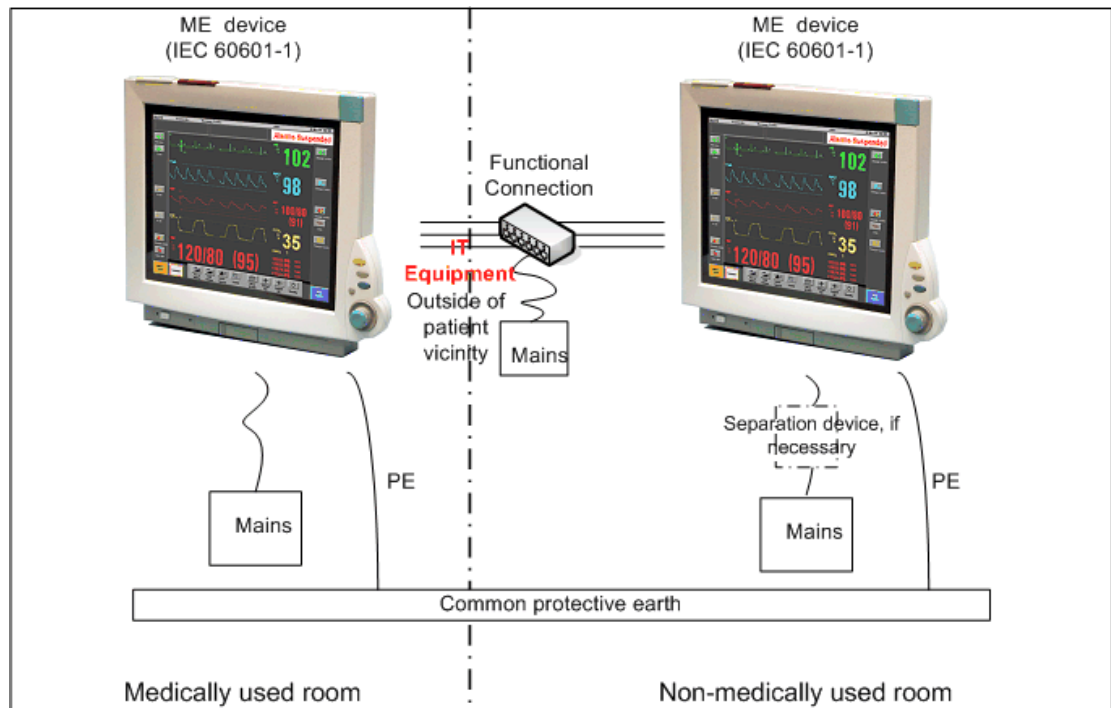

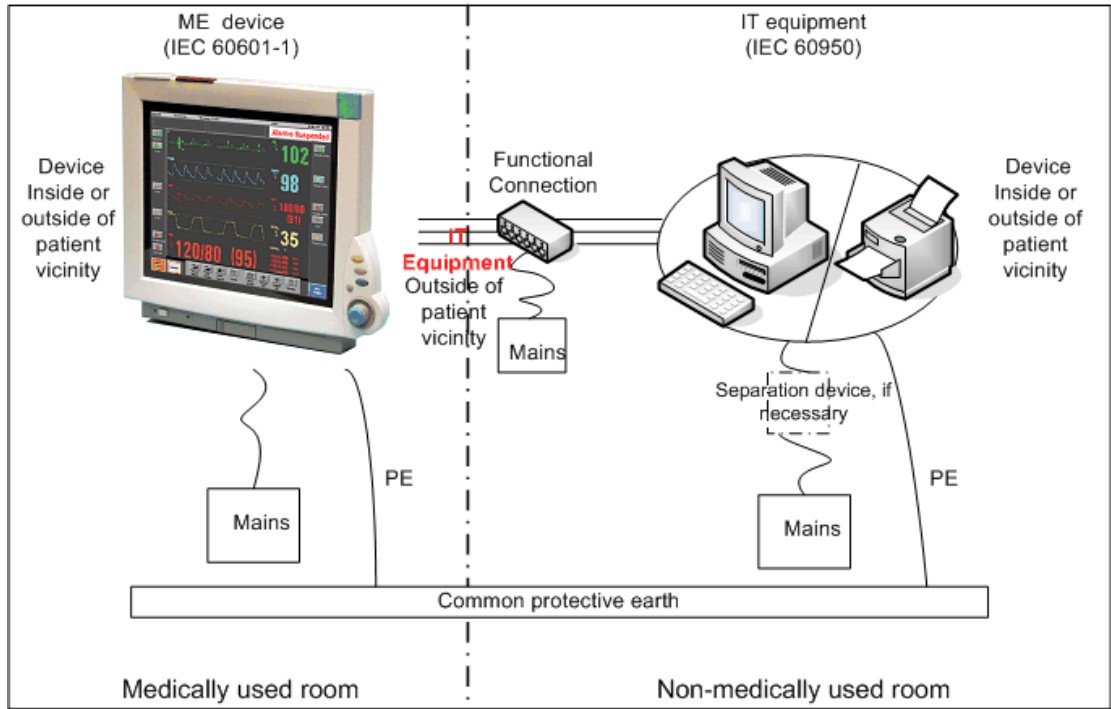

If you combine a medical device with a medical or non-medical device to form a medical electrical system according to IEC60601-1-1 using two separate protective earth connections and one of the devices is located in a non-medically used room creating a potential voltage difference, additional protective measures are required, e.g. usage of a separation device or additional protective earth connection. The medical electrical devices or IT equipment may be located in or outside the patient vicinity. After system installation incl. protective measures, a system test is required to ensure that the resulting equipment leakage current does not exceed the limits of IEC 60601-1-1.

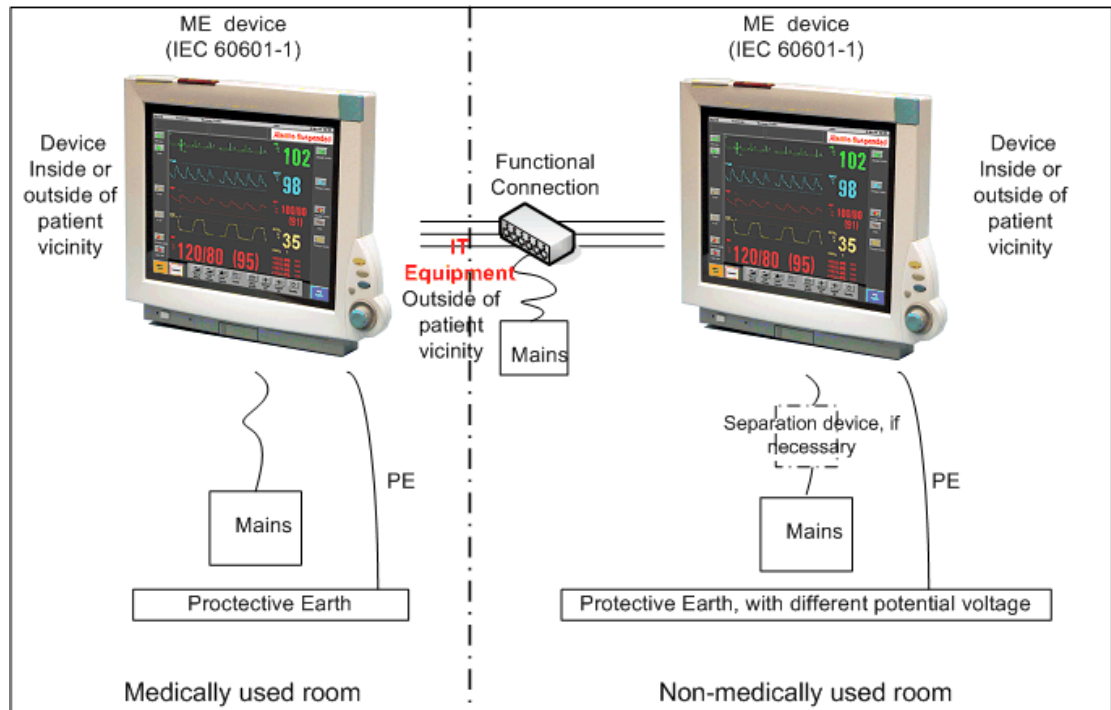

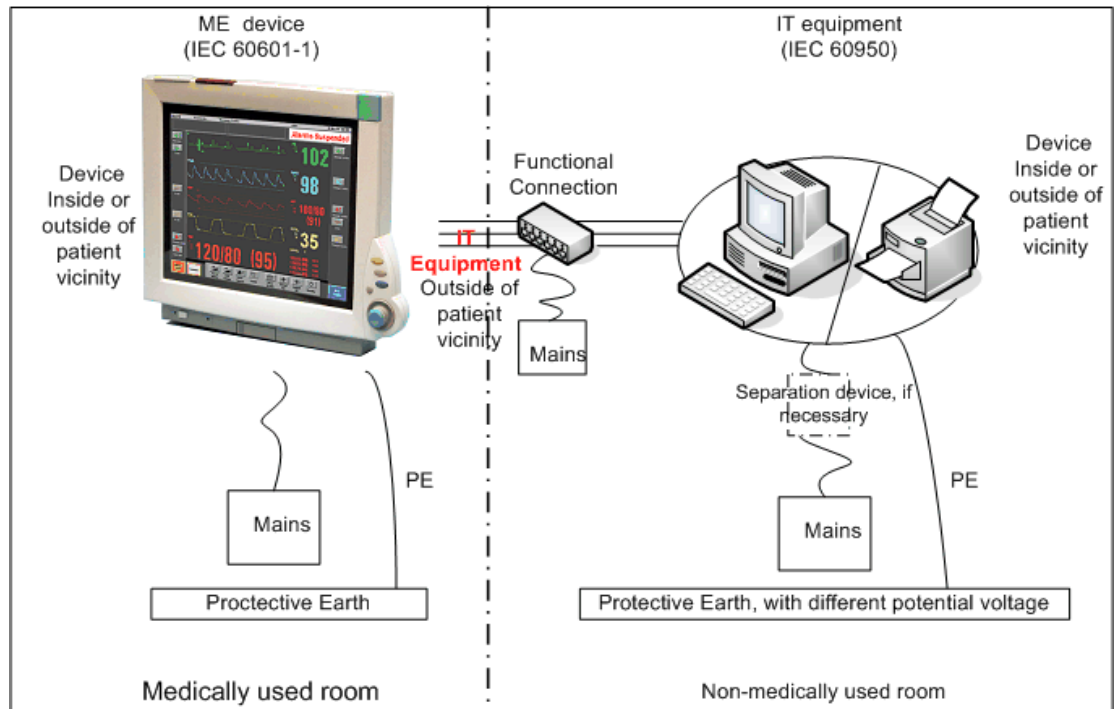

System Test Procedure

If the medical electrical device has already been tested as a standalone device e.g. during factory safety testing, an equipment leakage current test must only be performed once the device is connected to the LAN network. If the medical electrical system has not been tested as a standalone device, the device has to be tested as a standalone device (without connection to the system) and as part of the system (with connection to the system).

Connect the detachable power cord of the device under test to the safety analyzer's test mains port. Connect the enclosure test lead of the safety analyzer to the enclosure of the device under test, e.g. to the equipotential connector. Refer to the documentation that accompanies the safety analyzer for further details on how to set up the test.

Test	Expected test results
Equipment Leakage Current Test (Normal Condition)	Sys1 <= 100µA
Equipment Leakage Current Test (Single Fault Condition)	Sys2 <= 300µA

After the testing of the device as a standalone device and as part of the system, check that the resulting values (without connection and with connection to the system) do not differ by more than +/- 10% from each other.

If the devices in the medical electrical system are connected to a multiple portable socket outlet the resulting protective earth leakage current needs to be determined. All system components must be connected to the multiple portable socket outlet and be switched on during this measurement.

Test	Expected test results
Protective Earth Leakage Current of Multiple Socket Outlets	Sys3 <= 300µA

Refer to the documentation that accompanies the safety analyzer for further details on how to set up the test.

Preventive Maintenance Procedures

Noninvasive Blood Pressure Measurement Calibration

Carry out the noninvasive blood pressure measurement performance tests at least every two years , or as specified by local laws (whichever comes first).

Performance Assurance Tests

Some of the following test procedures must be performed in service mode. To enter service mode select **Operating Modes** in the main menu. Then select **Service Mode** and enter the password.

If required, open the screen menu in the monitor info line at the top of the screen and select **Service** to access the service screen. This is required particularly for Anesthetic Gas Module testing procedures.

Basic Performance Assurance Test

This section describes the basic performance test procedure. Please refer to the section When to Perform Tests for detailed information on when which test procedure is required.

Procedure:

Power on the monitoring system and go into demo mode. Check that each connected parameter (integrated, module, MMS, Gas Analyzer, Vuelink connected device) displays values.

Full Performance Assurance Test

The following sections describe the full performance testing procedures i.e. detailed testing of each parameter with a patient simulator or specified tools. Please refer to the section When to perform Tests for information on when which testing procedure is required.

ECG/Resp Performance Test

This test checks the performance of the ECG and respiration measurements.

Tools required: Patient simulator.

ECG Performance

1. Connect the patient simulator to the ECG/Resp connector.
2. Configure the patient simulator as follows:
 - ECG sinus rhythm.
 - HR = 100 bpm or 120 bpm (depending on your patient simulator).
3. Check the displayed ECG wave and HR value against the simulator configuration.
4. The value should be 100bpm or 120 bpm +/- 2 bpm.

Respiration Performance

1. Change the Patient Simulator configuration to:
 - Base impedance line 1500 Ohm.
 - Delta impedance 0.5 Ohm.
 - Respiration rate 40 rpm or 45 rpm.
2. The value should be 40 rpm +/- 2 rpm or 45 rpm +/- 2 rpm.

Test	Expected test results
ECG Performance Test	100bpm +/- 2bpm or 120bpm +/- 2bpm
Respiration Performance Test	40 rpm +/- 2 rpm or 45 rpm +/- 2 rpm

ECG Sync Performance Test

This test checks the performance of ECG synchronization between the monitor and a defibrillator. It only needs to be performed when this feature is in use as a protocol at the customer site.

Tools required:

- Defibrillator with ECG Sync and Marker Output.
 - Patient simulator.
1. Connect the patient simulator to the ECG connector and the defibrillator to the ECG Sync Output on the monitor.
 2. Set the patient simulator to the following configuration:
 - HR = 100 bpm or 120 bpm (depending on your patient simulator).
 - ECG sinus rhythm.
 3. Switch the defibrillator to simulation mode.
 4. Check that the marker pulse is displayed before the T-wave begins.

Test	Expected test results
ECG Sync Performance Test	Marker pulse is displayed before the T-wave begins

SpO2 Performance Test

This test checks the performance of the SpO2 measurement.

Tools required: none

1. Connect an adult SpO2 transducer to the SpO2 connector.
2. Measure the SpO₂ value on your finger (this assumes that you are healthy).
3. The value should be between 95% and 100%.

Test	Expected test results
SpO2 Performance Test	95% and 100%

Measurement Validation

The SpO₂ accuracy has been validated in human studies against arterial blood sample reference measured with a CO-oximeter. In a controlled desaturation study, healthy adult volunteers with saturation levels between 70% and 100% SaO₂ were studied. The population characteristics for those studies were:

- about 50% female and 50% male subjects
- age range: 18 to 45
- skin tone: from light to black

NOTE

A functional tester cannot be used to assess the accuracy of a pulse oximeter monitor. However, it can be used to demonstrate that a particular pulse oximeter monitor reproduces a calibration curve that has been independently demonstrated to fulfill a particular accuracy specification.

NBP Performance Test

This section describes NBP test procedures. The monitor must be in service mode and the screen “Service A” must be selected to perform these tests. The NBP Performance Test consists of:

- NBP Accuracy Test
- NBP Leakage Test
- NBP Linearity Test
- Valve Test

NBP Accuracy Test

This test checks the performance of the non-invasive blood pressure measurement. Connect the equipment as shown:

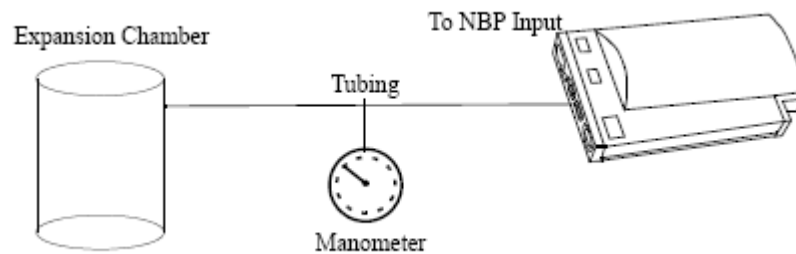

Tools required:

- Reference manometer (includes hand pump and valve), accuracy 0.2% of reading.
- Expansion chamber (volume 250 ml +/- 10%)
- Appropriate tubing.

In service mode, the systolic and diastolic readings indicate the noise of NBP channels 1 and 2 respectively. When static pressure is applied, the reading in NBP channel 1 should be below 50. The value in parentheses indicates the actual pressure applied to the system.

1. Connect the manometer and the pump with tubing to the NBP connector on the MMS and to the expansion chamber.
2. In service mode, select the **Setup NBP** menu.
3. Select **Close Valves: On**
4. Raise the pressure to 280 mmHg with the manometer pump.
5. Wait 10 seconds for the measurement to stabilize.
6. Compare the manometer values with the displayed values.
7. Document the value displayed by the monitor (**x1**).
8. If the difference between the manometer and displayed values is greater than 3 mmHg, calibrate the MMS. If not, proceed to the leakage test.
9. To calibrate the MMS, select **Close Valves off** then **Calibrate NBP** and wait for the instrument to pump up the expansion chamber. Wait a few seconds after pumping stops until **EnterPrVal** is highlighted and then move the cursor to the value shown on the manometer. If one of the following prompt messages appears during this step, check whether there is leakage in the setup:
 - NBP unable to calibrate—cannot adjust pressure
 - NBP unable to calibrate—unstable signal
10. Press **Confirm**.

If the INOP NBP Equipment Malfunction message occurs in monitoring mode, go back to service mode and repeat the calibration procedure.

NBP Leakage Test

The NBP leakage test checks the integrity of the system and of the valve. It is required once every two years and when you repair the monitor or replace parts.

1. If you have calibrated, repeat steps 2 to 6 from the accuracy test procedure so that you have 280 mmHg pressure on the expansion chamber.
2. Watch the pressure value for 60 seconds.
3. Calculate and document the leakage test value (**x2**).
 $x2 = P1 - P2$
where P1 is the pressure at the beginning of the leakage test and P2 is the pressure displayed after 60 seconds.
The leakage test value should be less than 6 mmHg.

NBP Linearity Test

1. Reduce the manometer pressure to 150 mmHg.
2. Wait 10 seconds for the measurement to stabilize.
3. After these 10 seconds, compare the manometer value with the displayed value.
4. Document the value displayed by the monitor (x3)
5. If the difference is greater than 3 mmHg, calibrate the MMS (see steps 9 to 10 in the accuracy test procedure).

Valve Test

1. Raise the pressure again to 280 mmHg.
2. Select **Close valves: Off**.
3. Wait five seconds and then document the value displayed. The value should be less than 10 mmHg.
4. Document the value displayed by the monitor (x4).

Expected Test Results for NBP Accuracy Test, Leakage Test, Linearity Test & Valve Test

Test	Expected test results
Accuracy test	x1 = value displayed by monitor Difference \leq 3mmHg
Leakage test	x2 = leakage test value x2 < 6 mmHg
Linearity test	x3 = value displayed by monitor Difference \leq 3mmHg
Valve Test	x4 = value < 10 mmHg

Invasive Pressure Performance Test

This test checks the performance of the invasive pressure measurement.

Tools required: Patient simulator.

1. Connect the patient simulator to the pressure connector.
2. Set the patient simulator to 0 pressure.
3. Make a zero calibration.
4. Configure the patient simulator as P(static) = 200 mmHg.
5. Wait for the display.

- The value should be $200 \text{ mmHg} \pm 5 \text{ mmHg}$. If the value is outside these tolerances, calibrate the Invasive Pressure measurement. If the measurement was calibrated with a dedicated reusable catheter, check the calibration together with this catheter.

Table 4:

Test	Expected test results
Invasive Pressure Performance Test	$200 \text{ mmHg} \pm 5 \text{ mmHg}$

Temperature Performance Test

This test checks the performance of the temperature measurement.

Tools required: Patient simulator (with 0.1°C or 0.2°F).

- Connect the patient simulator to the temperature connector.
- Configure the patient simulator to 40°C or 100°F .
- The value should be $40^\circ\text{C} \pm 0.2^\circ\text{C}$ or $100^\circ\text{F} \pm 0.4^\circ\text{F}$.

Table 2:

Test	Expected test results
Temperature Performance Test	$40^\circ\text{C} \pm 0.2^\circ\text{C}$ or $100^\circ\text{F} \pm 0.4^\circ\text{F}$

M3014A Capnography Extension Performance Tests

The procedures below describe the mainstream and sidestream CO₂ performance tests for the M3014A Capnography Extension.

Mainstream CO₂ Accuracy Check

Tools Required:

- three airway adapters
- Verification Gas M2506A
- Gas cylinder regulator M2505A

You also need a local barometric pressure rating received from a reliable local source (airport, regional weather station or hospital weather station) which is located at the same altitude as the hospital.

Procedure:

- Attach the M2501A CO₂ sensor to the patient monitor. Attach an airway adapter to the sensor. Make sure that the sensor is disconnected from the patient circuit.
- Switch on the patient monitor.
- Enter the monitor's Service Mode.

4. Using the sensor status provided in the M2501A Serial protocol, wait for the M2501A sensor to warm up to its operating temperature.
5. The default setting for gas temperature is 22°C. If the gas temperature is significantly above or below this value, correct the gas temperature setting.
6. Zero the sensor on the airway adapter being used in this test. Ensure Zero Gas is set to Room Air
7. Attach a regulated flowing gas mixture of 5% CO₂, balance N₂ to the airway adapter.
8. Set the gas correction to off.
9. Allow a few seconds for the gas mixture to stabilize and observe the CO₂ value. The expected value is 5% of the ambient pressure ± 2 mmHg

NOTE

Make sure that you follow the above steps correctly. If the sensor fails this check it must be exchanged. The sensor cannot be calibrated.

Example for an expected test result:

The expected test result for an altitude of 0 m (sea level) at approximately 760 mmHg ambient pressure is:

Table 6:

Test	Expected test results (x1)	Acceptance Range
Mainstream CO ₂ Accuracy Test	5% of 760 mmHg pressure ± 2 mmHg	36 mmHg - 40 mmHg

NOTE

The expected test results will differ depending on the conditions (i.e. altitude or ambient pressure).

Sidestream CO₂ Accuracy Check

Tools Required:

- Cal gas flow regulator M2267A
- Cal tube 13907A
- Verification Gas M2506A
- Straight Sample Line M2776A

You also need a local barometric pressure rating received from a reliable local source (airport, regional weather station or hospital weather station) which is located at the same altitude as the hospital.

Procedure:

1. Attach the M2741A CO₂ sensor to the patient monitor. Attach the sample line and the cal tube to the sensor. Make sure that the sensor is disconnected from the patient circuit.
2. Switch on the patient monitor.
3. Enter the monitor's Service Mode.

4. Using the sensor status provided in the M2741A Serial protocol, wait for the M2741A sensor to warm up to its operating temperature.
5. Zero the sensor. Ensure Zero Gas is set to Room Air
6. Attach a regulated flowing gas mixture of 5% CO₂, balance N₂ to the cal tube.
7. Set the gas correction to off.
8. Allow a few seconds for the gas mixture to stabilize and observe the CO₂ value. The expected value is 5% of the ambient pressure ± 2 mmHg

NOTE

Make sure that you follow the above steps correctly. If the sensor fails this check it must be exchanged. The sensor cannot be calibrated

Example for an expected test result:

The expected test result for an altitude of 0 m (sea level) at approximately 760 mmHg ambient pressure is:

Test	Expected test results (x2)	Acceptance Range
Sidestream CO ₂ Accuracy Test	5% of 760 mmHg pressure ± 2 mmHg	36 mmHg - 40 mmHg

NOTE

The expected test results will differ depending on the conditions (i.e. altitude or ambient pressure).

Sidestream CO₂ Flow Check

Check the flow rate in the Sidestream CO₂ extension as follows:

1. Connect the flowmeter to the sample line
2. Check on the flowmeter the flow that the Sidestream CO₂ extension pump draws. It should be 50 ml/min \pm 10 ml/min. If the value is not within tolerance check your setup again and perform another flow check. If it fails again, the sensor must be replaced. The sensor cannot be calibrated.

Microstream CO₂ Performance Test

Allow five seconds between individual service procedures to ensure stable equipment conditions. When certain monitor procedures are running, service procedures are not possible and trying to start them will result in a message **Service Operation Failed** in the monitor's status line. Wait until the monitor completes the current operation, then restart the service procedure.

This test checks the performance of the Microstream CO₂ measurement. The Microstream CO₂ measurement can either be integrated into the IntelliVue MP5 monitor or, for other IntelliVue monitors, into the M3015A MMS Extension. The Microstream CO₂ performance test is required once per year and when the instrument is repaired or when parts are replaced.

This test uses calibration equipment that you can order (see the *Parts* section for the part number). The procedure is summarized in the following steps. Refer to the documentation accompanying the equipment for detailed instructions.

Tools Required:

- Standard tools, such as screwdriver, tweezers
- Electronic flowmeter, M1026-60144
- Gas calibration equipment:
 - Cal 1 gas 15210-64010 (5% CO₂)
 - Cal 2 gas 15210-64020 (10% CO₂)
 - Cal gas flow regulator M2267A
 - Cal tube 13907A
 - Calibration Line M3015-47301

You also need a local barometric pressure rating received from a reliable local source (airport, regional weather station or hospital weather station) which is located at the same altitude as the hospital.

The CO₂ calibration for the Microstream extension consists of the following steps:

- Leakage check
- Barometric pressure check and calibration, if required.
- Pump check
- Flow check and calibration, if required
- Noise check
- CO₂ Cal check and calibration, if required
- CO₂ Cal verification using 2nd cal gas

Perform all checks in the same session.

Leakage Check

The leakage check consists of checking the tubing between:

- the pump outlet and the mCO₂ outlet and
- the pump inlet and FilterLine inlet.

Check the user's guide of the flowmeter for details on how to make a correct flow reading.

Part 1

1. Go into service mode and select **Setup CO2** menu.
2. Connect a FilterLine to the Microstream CO₂ input to start the pump running.
3. Check the ambient pressure and the cell pressure shown in the monitor's status line. The cell pressure should be approximately 20 mmHg lower than ambient pressure.
4. Connect the flowmeter outlet to the FilterLine inlet using a flexible connecting tube.
5. Block the mCO₂ outlet using your fingertip and observe the flowmeter display. The value on the flowmeter (**x1**) should decrease to between 0 and 4 ml/min, accompanied by an audible increase in pump noise. If the value is within the tolerance limits, continue with part 2 of the leakage check.
6. If the value is outside the tolerance limits, there is a leakage between the pump outlet and the mCO₂ outlet.
7. Open the MMS Extension or MP5 and check the tubing connections at the pump outlet and the extension gas outlet. If the connections are good, then there is a leakage in the tubing and you must exchange the MMS Extension or the mCO₂ Assembly of the MP5 respectively.

Part 2

1. Disconnect the flowmeter from the Part 1 setup and connect the flowmeter inlet to the M3015A gas outlet or the MP5 mCO₂ gas outlet.
2. Leave the Filterline connected to the M3015A inlet or the MP5 mCO₂ inlet..
3. Block the inlet of the FilterLine using your fingertip and observe the flowmeter display. The value on the flowmeter (**x2**) should decrease to between 0 and 4 ml/min, accompanied by an audible increase in pump noise. The cell pressure shown in the status line on the display should decrease to between 300 and 500 mmHg. Do not block the inlet for longer than 25 seconds as this will lead to an "Occlusion" INOP. If the value is within the tolerance limits, there are no leakages and the leakage check is completed; proceed to the pump check.
4. If the value is not within the tolerance limits, there is a leakage between the FilterLine inlet and the pump inlet.
5. Check the FilterLine connections and open the M3015A or MP5 to check the tubing connections at the pump inlet and the M3015A or MP5 mCO₂ gas inlet. If the connections are good, try replacing the FilterLine and repeating the leakage check. If the situation remains, there is a leakage in the tubing and the M3015A or the mCO₂ assembly of the MP5 must be exchanged.

Barometric Pressure Check and Calibration

Check the barometric pressure value in the M3015A MMS Extension or the MP5 as follows:

1. Go into service mode and select **Setup CO₂** menu.
2. Connect a FilterLine to the Microstream CO₂ input. This activates the pump in the M3015A MMS Extension or the MP5.
3. The status line at the bottom of the screen displays “CO₂ pressure reading (ambient/cell) xxx/yyy” where xxx is the ambient pressure and yyy is the measured cell pressure. Check whether the ambient pressure value (**x3**) matches (within the acceptable tolerance of ± 12 mm Hg) the reference value you have received. If so, proceed to the leakage check. If the value is not correct, calibrate as follows.
 - a. Select **CO₂** then select **Barom. Press** to activate a table of values.
 - b. Select the value in the table which matches the reference value received from a reliable local source (airport, regional weather station or hospital weather station). (The values are displayed with a resolution of 2 mmHg up to 500 mmHg and a resolution of 1 mmHg from 500 mmHg to 825 mmHg.) Note: the selected value must be within $\pm 10\%$ of the current measured ambient pressure, otherwise an error message will occur at restarting the monitor.
 - c. Confirm the barometric pressure setting.
 - d. Check that the ambient pressure displayed in the status line at the bottom of the screen is the same as the value which you selected from the list in step b.

Pump Check

1. Connect the flowmeter inlet to the mCO₂ gas outlet.
2. Connect the FilterLine to the mCO₂ inlet.
3. Block the inlet of the FilterLine using your fingertip and observe the cell pressure on the monitor display. The cell pressure (**x4**) should be more than 120 mmHg below the ambient pressure shown. If the pressure difference is less than 120 mmHg, the pump is not strong enough and you should replace it, irrespective of the Pump OpTime.

Flow Rate Check and Calibration

Check the flow rate in the M3015A MMS Extension or the MP5 as follows:

1. Connect the flowmeter to the CO₂ FilterLine.
2. Check on the flowmeter the flow that the M3015A MMS Extension or MP5 mCO₂ pump draws (**x5**). It should be 50 ml/min \pm 7.5 ml/min. If the value is within tolerance, proceed to the CO₂ Gas calibration check. If the value is not within tolerance, calibrate as follows.
3. Adjust the flow in the instrument by selecting **Increase Flow** or **Decrease Flow** until it is as close as possible to 50 ml per minute as indicated on the flowmeter gauge.
4. When you are satisfied that the flow is set as close as possible to 50 ml per minute, select **Store Flow** and confirm the setting. If you do not store the adjusted flow within 60 seconds of the adjustment, the old flow setting is restored.

5. If you cannot adjust the flow to within tolerance, replace the pump . If you still cannot make the flow adjustment, this indicates a fault in the measurement extension, which must be replaced.

Note that the pump can only be replaced on M3015A with the old hardware Rev. A (i.e. Serial No. DE020xxxxx)

Noise Check

1. With the monitor in service mode, select **Setup CO₂** menu.
2. Disconnect the flowmeter and connect the 5% calibration gas and flow regulator in its place.
3. Open the valve to apply the 5% calibration gas and wait until the value is stable.
4. Check the noise index (**x6**) displayed next to the CO₂ value on the display (this indicates the level of noise on the CO₂ wave). If the value exceeds 3 mmHg, replace the measurement extension.

CO₂ Gas Measurement Calibration Check

After switching the measurement extension on, wait at least 20 minutes before checking the calibration. Check the calibration of the CO₂ gas measurement as follows:

1. Check that the 5% calibration gas and flow regulator are connected.
2. Calculate the expected measurement value in mmHg as follows:
 $0.05 \times (\text{ambient pressure}) = \text{value mmHg}$
 for example $0.05 \times 736 = 36.8 \text{ mmHg}$ (with an ambient pressure of 736 mmHg)
3. Open the valve on the flow regulator to allow 5% CO₂ gas to flow into the extension. Allow the value to stabilize.
4. Check that the value on the instrument (measurement value on the main screen, **x7**) matches the calculated mmHg value $\pm 2.6 \text{ mmHg}$. If the value is outside the tolerance, calibrate as described in step 1 in this procedure onwards.
5. Disconnect the 5% calibration gas and connect the 10% calibration gas.
6. Calculate the expected measurement value and tolerance in mmHg as follows:
 $0.1 \times (\text{ambient pressure}) = \text{value mmHg}$
 $\pm 0.07 \times (\text{value mmHg}) = \text{tolerance}$
 for example $0.1 \times 737 \text{ mmHg} = 73.7 \text{ mmHg}$ (with an ambient pressure of 737 mmHg)
 $\pm 0.07 \times 73.7 \text{ mmHg} = \pm 5.16 \text{ mmHg}$ tolerance
7. Open the valve on the flow regulator to allow 10% CO₂ gas to flow into the extension. Allow the value to stabilize.
8. Check that the value on the instrument (**x8**) matches the calculated mmHg value within the calculated tolerance. If so, the measurement extension is correctly calibrated. If the value is outside the tolerance, calibrate as follows.
9. If not already connected, connect the 5% calibration gas.
10. Select **Cal . CO₂**.
11. Select the value for the calibration gas. (The default value is 5.0%.)

12. Open the valve on the calibration gas to allow CO₂ gas to flow into the extension. Allow the value to stabilize before the start of the calibration. Leave the valve open until the instrument gives a prompt that gas can be removed.
13. The extension calibrates and prompts when calibration is successful.

Calibration Verification

1. Reopen the 5% gas valve and allow the value to stabilize.
2. Check that the value displayed on the monitor is correct within the tolerance (see step above).
3. Disconnect the 5% calibration gas and connect the 10% calibration gas.
4. Open the valve on the flow regulator to allow 10% CO₂ gas to flow into the extension. Allow the value to stabilize.
5. Check that the value displayed on the monitor is correct within the tolerance (see step above).

If one or both values are not within tolerances, you must exchange the M3015A MMS Extension or the MP5 mCO₂ Assembly.

Test	Expected Test Results
Leakage Check parts 1 and 2	x1 = value of part 1 leakage check on flowmeter (x1 < 4.0 ml/min) x2 = value of part 2 leakage check on flowmeter (x2 < 4.0 ml/min)
Barometric Pressure Check	x3 = difference between the reference pressure and the measured ambient pressure displayed on the monitor (x3 < 12 mmHg)
Pump Check	x4 = difference in pressure between cell pressure and ambient pressure displayed on the monitor during occlusion (x4 > 120 mmHg)
Flow Check	x5 = difference between measured value and 50.0 ml/min (x5 < 7.5 ml/min)
Noise Check	x6 = noise index displayed on monitor (x6 < 3.0)
CO ₂ Gas Calibration Check	x7 = difference between measured CO ₂ value and calculated value, based on 5% CO ₂ cal. gas. (x7 < 2.6 mmHg)
CO ₂ Cal Verification	x8 = difference between measured CO ₂ value and calculated value, based on 10% CO ₂ cal. gas. (x8 < ± {0.07 x value calculated})

Reset Time Counters

NOTE

This procedure only applies to M3015A with the old hardware Rev. A (i.e. Serial No. DE020xxxxx)

You must check the time counters on the Microstream CO₂ extension before calibrating the instrument. As well, when parts are replaced, the appropriate counters must be reset to zero.

The counters for CO₂ pump, IR Src and Last Cal are displayed in the status line. The values are updated when entering the **Setup CO2** menu.

Observe the following guidelines:

- When calibrating the CO₂ extension, if no parts have been replaced, check the displayed values of **Reset PumpOpTime** and **Reset IRSourceTime** selections to make sure that they are within suggested guidelines for use (15,000 hours of continuous use). If the counter time is greater than 15,000 hours, replace the appropriate part. See *Repair and Disassembly* for details.
- When calibrating the CO₂ extension, if parts have been replaced, reset the appropriate values using the **Reset PumpOpTime** and **Reset IRSourceTime** selections. See *Repair and Disassembly* for details.

Resetting the PumpOpTime generates the INOP: “CO₂ OCCLUSION”. To clear this INOP you must perform a flow check and store the flow in service mode (select **Store Flow**).

CO2 Pump / CO2 Scrubber Replacement

NOTE

This procedure only applies to M3015A with the old hardware Rev. A (i.e. Serial No. DE020xxxxx)

Refer to the Repair and Disassembly section for the replacement procedures.

Cardiac Output Performance Test

These tests check the performance of the cardiac output measurement.

1. Connect the patient simulator to the C.O. module using the patient cable.
2. Configure the patient simulator as follows:
Injection temperature: 2 °C
Computation Const: 0.542
(Edward's Catheter)
Flow: 5 l/min
3. Check displayed value against the simulator configuration.
4. Expected test result: C.O. = 5 +/- 1 l/min.

Test	Expected test results
Cardiac Output Performance Test	C.O. = 5 +/- 1 l/min

Service Tool Procedure, Version 1

This procedure applies for Service Tool M1012-61601 in combination with C.O. modules without option C10 and M3012A MMS extensions with option C05.

1. In monitoring mode, connect the C.O. interface cable to the module.
2. Connect one side of the service tool to the injectate receptacle of C.O. interface cable and the other side to catheter cable receptacle.
3. Enter the **C.O. Procedure** window and check the results. The expected test result is:

Tblood = 37.0°C +/- 0.1°C

Test	Expected test results
Cardiac Output Service Tool Procedure Version 1	Tblood = 37.0°C +/- 0.1°C

Service Tool Procedure, Version 2

This procedure applies only for Service Tool M1012-61601 in combination with C.O. modules with option C10 and for the M3012A MMS Extension with option C10.

1. In monitoring mode, connect the C.O. interface cable to the module.
2. Connect one side of the service tool to the injectate receptacle of the C.O. interface cable and the other side to the catheter cable receptacle.
3. Enter **C.O. Procedure** window and check results for:
 - Method of measurement
 - Arterial Catheter constant
 - Tblood

The expected results are:

- Transpulmonary
 - 341
 - Tblood = 37.0°C +/- 0.1°C
4. Make sure the main alarms are switched on.
 5. Disconnect the Catheter cable receptacle from the service tool
 6. Enter the Setup C.O Window and change the method of measurement to “Right Heart”
 7. Enter the C.O. Procedure window and check the Tinj value. The expected result is:
Tinj = 0.0°C +/- 0.1°C

Test	Expected test results
Cardiac Output Service Tool Procedure Version 2	Tinj = 0.0°C +/- 0.1°C

Power Loss Alarm Buzzer Performance Test (only if Multi-Port Nurse Call Connector Board is installed)

1. Switch on the monitor.
2. Remove the battery and disconnect the monitor from AC power.
3. The Power Loss Alarm Buzzer should beep for about one minute.
4. To switch off the alarm sound, either press the power button, connect the monitor to AC power or insert a battery

Test	Expected test results
Power Loss Alarm Buzzer Performance Test	Beep for one minute

IntelliVue 802.11 Bedside Adapter Communication Test

1. Make sure the LAN cable is disconnected from the rear of the monitor, then switch on the monitor.
2. Go into Service Mode and select **Main Setup -> Network -> Setup WLAN**. In the **Setup WLAN** menu:
 - set **Mode** to either **802.11Ah**, **802.11G**, **802.11Bg** (not recommended), **Auto** (not recommended) or **None** (this setting disables the wireless LAN functionality permanently), to match your wireless infrastructure installation.
 - set **SSID** to match your installation.
 - set the **Country** code to "1000". Setting the country code to this value will automatically adjust the regulatory domain to match the configuration of the infrastructure. Do not set the country code to values other than "1000" unless otherwise instructed.
 - set the **Security Mode** to **WPA (PSK)** and enter the **WPA password** (string between 8 and 63 characters).
3. Select **Main Setup -> WLAN Diagnostic** to access the service window.
4. Proper installation of the IntelliVue 802.11 Bedside Adapter is assured by connecting to an access point over the wireless link. Place the monitor with the IntelliVue 802.11 Bedside Adapter installed in close proximity to the access point (e.g. if the access point is mounted on the ceiling, place the monitor directly below). Wait until the **Conn. Status** field in the service window shows *Authenticated* (for Rel. C.0 monitors) or *Connected* (for Rel D.0 or higher). Take the monitor approximately 5 m away from the access point. There should be no walls or other obstacles between the monitor and the access point. The following should apply:

- Observe the **RSSI** (Received Signal Strength Indicator) value for at least 5 - 10 seconds. The **RSSI** value will fluctuate but should stay above 30 in a 5 m distance from the access point used. The wireless link should be active, i.e. the **Conn. Status** field should be *Authenticated* (for Rel. C.0 monitors) or *Connected* (for Rel D.0 or higher), and the other fields should contain values. If the **RSSI** value is significantly lower, check the distance to the access point and the antenna orientation at the monitor. The antenna orientation should be vertical, but the physical placement of the monitor or other equipment within its vicinity as well as walls or other obstacles may influence the antenna orientation required to receive the best RSSI value.
5. If this test fails, retry in a different physical area with a different access point.
 6. Perform the Wireless Switch test blocks as described in the Philips IntelliVue 802.11 a/g Infrastructure Installation and Configuration Guide.

Test	Expected test results
IntelliVue 802.11 Bedside Adapter Performance Test	RSSI value above 30

IIT Communication Test

1. Make sure the LAN cable is disconnected from the rear of the monitor, then switch on the monitor.
2. Go into Configuration mode and, in the **Network** menu, set the **RF Access Code** in each profile to match your installation.
3. Go into Service Mode. Select **Main Setup -> Instr. Telemetry** to access the Instrument Telemetry Service window.
4. Proper installation of the IIT module is assured by connecting to an access point over the wireless link. Place the monitor with the IIT module installed in close proximity to the access point (e.g. if the access point is mounted on the ceiling, place the monitor directly below). Wait until the **Conn. Status** field in the Instrument Telemetry Service window shows *Active*. Take the monitor approximately 5 m away from the access point. There should be no walls or other obstacles between the monitor and the access point. The following should apply:
 - Observe the **RSSI** (Received Signal Strength Indicator) value for at least 5 - 10 seconds. The **RSSI** value should be around -50 ± 10 in a 5 m distance from the access point used and the IIT link should be active, i.e. the **Conn. Status** field should be *Active* and the other fields should contain values. If the **RSSI** value is significantly lower, check the distance to the access point and the antenna orientation at both the monitor and the access point (both should be vertical).
 - Remove the antenna. The **RSSI** value should be around -90 ± 10 . The IIT link may be active but the connection could be unreliable. The **Conn. Status** field may toggle between *Inactive* and *Seeking*. If the difference between the **RSSI** values measured with and without antenna is significantly lower, check the antenna and the antenna connector for damage and verify that the cable from the IIT adapter to the antenna connector plate is connected properly.
5. If this test fails, retry in a different physical area with a different access point.

Error Conditions:

- The field **MAC Instr. Tele** should show a value **unequal to** 0000 0000 0000. If it does not, there is a communication problem between the monitor and the IIT adapter.
 - With an incorrect RF Access Code or an incorrect or defective antenna installation, the fields **IP Address, Server IP, Subnet Mask**, and **RSSI** in the Instrument Telemetry Service window will stay blank. The field **Conn. Status** will slowly toggle between *Inactive* and *Seeking*.
6. Perform the Access Point Controller (APC) test blocks as described in the Philips IntelliVue Wireless Network Installation and Configuration Guide.

Short Range Radio (SRR) Performance Test

1. Make sure that the short range radio interface is configured as follows: **SRR On** and appropriate channel selected.
2. Assign a telemetry transceiver to the IntelliVue Monitor according to the procedure described in the Instructions for Use of the patient monitor.
3. Check that the following conditions are fulfilled:
 - a. Place the telemetry transceiver close to the monitor.
 - b. The telemetry transceiver status is displayed on the monitor in the measurement selection window.
 - c. Waves or numerics from the telemetry transceiver are displayed on the monitor. There are no dropouts or gaps in waves or numeric transmission.
 - d. The battery status of the telemetry transceiver is displayed in the measurement selection window.
 - e. The Signal Quality Indicator shows at least 
4. Check that the data from the telemetry transceiver is transmitted to the monitor within a 1m radius and that there are no dropouts or gaps in waves or numerics.
5. Check whether the connection remains stable within a 5m radius from the monitor.
6. Switch on all telemetry transceivers used on the site and check that there are no interferences between the transceivers and their assigned monitors.
7. Check and record the coverage area of the telemetry transceivers and inform the customer about this coverage area.

Reporting of Test Results

Philips recommends all test results are documented in accordance with local laws. Authorized Philips personnel report test result back to Philips to add to the product development database. While hospital personnel (biomedical engineers or technicians) do not need to report results to Philips, Philips recommends that they record and store the test results in accordance with local laws.

The following table lists what to record after completing the tests in this chapter. Record the results in the empty column in Table 16.

The following is a guide as to what your documentation should include:

- Identification of the testing body (for example, which company or department carried out the tests).
- Name of the person(s) who performed the tests and the concluding evaluation.
- Identification of the device(s) and accessories being tested (serial number, etc.).
- The actual tests (incl. visual inspections, performance tests, safety and system tests) and measurements required
- Date of testing and of the concluding evaluation.
- A record of the actual values of the test results, and whether these values passed or failed the tests.
- Date and confirmation of the person who performed the tests and evaluation.

The device under test should be marked according to the test result: passed or failed.

Carrying Out and Reporting Tests

Test Report

Testing Organization: Name of testing person:	Test before putting into service (reference value) Recurrent Test Test after Repair
Responsible Organization:	
Device Under Test:	ID-Number
Product Number:	Serial No.:
Accessories:	
Measurement Equipment (Manufacturer, Type, Serial No.):	
Functional Test (parameters tested):	

Test and Inspection Matrix

Test Block	Test or Inspection to be Performed	Expected Test Results	Record the Results (mandatory for Philips Personnel only)	
			What to record	Actual Results
Visual Inspection	Perform Visual Inspection	Pass or Fail	V:P or V:F	
Power On	Power on the unit. Does the self-test complete successfully	If Yes, Power On test is passed	PO:P or PO:F	
Noninvasive Blood Pressure Performance Tests	Perform the Accuracy Test	X1 = value displayed by monitor Difference \leq 3mmHg	PN:P/X1 or PN:F/X1	
	Performance Leakage Test	X2 = leakage test value X2 < 6 mmHg	PN:P/X2 or PN:F/X2	
	Performance Linearity Test	X3 = value displayed by monitor Difference \leq 3mmHg	PN:P/X3 or PN:F/X3	
	Performance Valve Test	X4 = value < 10 mmHg	PN:P/X4 or PN:F/X4	
Temperature Performance Test	Perform the Temperature Performance Test	X1 = 40°C \pm 0.2°C or 100°F \pm 0.4°F	PT: P/X1 or PT: F/X1	
All other performance tests	Perform the remaining parameter performance tests, if applicable	See expected results in test procedures	P: P or P: F	
Safety (4)	Perform Safety Test (4): Patient Leakage Current - Single Fault Condition, mains on applied part.	Maximum leakage current (X1): \leq 50 μ A	S(4): P/X1 or S(4): F/X1	
System (Sys 1-2)	Perform the system test according to subclause 19.201 of IEC/EN 60601-1-1, if applicable, after forming a system	Equipment Leakage Current: Sys1 \leq 100 μ A (Normal Condition) Sys2 \leq 300 μ A (Single Fault Condition)	Sys: PSys1/PSys2 or Sys: FSys1/FSys2	

Test Block	Test or Inspection to be Performed	Expected Test Results	Record the Results (mandatory for Philips Personnel only)	
			What to record	Actual Results
System (Sys 3)	Perform the system test according to subclause 19.201 of IEC/EN 60601-1-1, if applicable, after forming a system	Protective Earth Leakage Current if medical electrical system components are connected to the same Multiple Portable Socket Outlet: Sys3 \leq 300 μ A	Sys: P Sys3 or Sys: F Sys3	
Key: P = Pass, F = Fail, X or Sys = test value to be recorded				

NOTE

All values for current and voltage are the root mean square (r.m.s.) values, unless otherwise stated.

Evaluation:

	Yes	No
Safety and Functional Test passed		
Repair required at a later date, safety and functional test passed		
Device must be taken out of operation until repair and passed tests		
Device failed and must be taken out of operation.		

Notes:**Next Recurrent Test:**

Name: _____

Date/Signature: _____

Evaluation of Test Results

The evaluation of the test results must be performed by appropriately trained personnel with sufficient product, safety testing and application knowledge.

If any test results are between 90% and 100% of the respective expected result, the previously measured reference values must be taken into consideration for the assessment of the electrical safety of the device under test. If no reference values are available, you should consider shorter intervals between upcoming recurrent tests.

NOTE

If any single test fails, testing must be discontinued immediately and the device under test must be repaired or labeled as defective. Be sure to inform the user about the test failure in writing.

Other Regular Tests

The care and cleaning requirements that apply to the monitor and its accessories are described in the Instructions for Use. This section details periodic maintenance procedures recommended for the monitor and its accessories.

Locking/Unlocking Touch Operation

To temporarily disable touchscreen operation of the monitor, press and hold the **Main Screen** key. The message “Touch disabled, press Main Screen” will appear on the screen. Press and hold the **Main Screen** key again to re-enable touchscreen operation.

Battery Handling, Maintenance and Good Practices

This section provides some information on how to handle and maintain the battery in order to get the best usage from it. Additionally, some good working practices are also given regarding the correct disposal of the battery.

NOTE

If your MP2/X2 is connected to an IntelliVue Information Center, you should make sure that the IIC uses the text catalog revision F.0 or later, otherwise battery INOPs may not display correctly on the IIC. Consult your IIC documentation for instructions on upgrading the text catalog.

About the Battery

When monitoring a patient, **one** Philips M4607A rechargeable Lithium Ion battery must **always** be inserted into the battery compartment on the right side of the MP2/X2. This applies even when you are running the MP2/X2 external power, either via the external power supply or when connected to a host monitor. The battery has the effect of sealing the battery compartment, thereby preventing the ingress of fluids or foreign bodies. A severe yellow INOP (! ! **INSERT BATTERY**) will be issued if the monitor is connected to AC mains without a battery fully inserted in the battery compartment. This INOP will persist until a battery is loaded.



Battery compartment

To use the MP2/X2 with battery power, disconnect it from the host monitor or the external power supply (M8023A).

The rechargeable Lithium-Ion Mangan battery used in the MP2/X2 is regarded as a *Smart* battery because it has built-in circuitry. (This circuitry communicates battery-status information to the Monitor.)

To get the most out of the battery, observe the following guidelines:

- Condition the battery only upon maintenance request prompt on display.
- **If a battery shows damage or signs of leakage, replace it immediately. Do not use a faulty battery in the MP2/X2.**
- Capabilities of integrated battery charger: 10.8 V, 1 mAh (typ.)
Actual current / voltage: depends on smart battery request and monitor configuration
The approximate charging time is 2 hours with the monitor switched off and up to 12 hours or more during monitor operation, depending on the monitor configuration.

Checking the Battery Status

When the MP2/X2 is connected to the external power supply (M8023A), the battery charges automatically. The battery can be charged remotely from the MP2/X2 by using the battery charger. Use only the M8043A Smart battery charger with the additional adapter.

Battery status (level of charge) is indicated in several ways:

- LED on the front panel of the Monitor.
- Battery gauge.
- Display of battery time below gauge.
- Battery status window.
- INOP messages.

The AC Power LED is only on when the power cord is connected and AC power is available to the Monitor. In this case, the battery can be either charging or fully charged.

The battery LED can be yellow, or red depending on the following conditions:

Battery LED Colors	If the MP2/X2 is connected to a host monitor or external power supply , this means	If the monitor is running on battery power, this means
Yellow	battery charging	
Red, flashing		≤ 10 minutes power remaining
Red, flashes intermittently	battery or charger malfunction ^{1,2}	battery or charger malfunction ^{1,2}

¹ indicated by malfunction symbol and INOP

² for further details see Troubleshooting section

Battery Status on the Main Screen

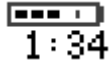



Battery status information can be configured to display permanently on all Screens. It shows the status of the battery, with the battery power remaining and, when the battery is not charging, an estimate of the monitoring time this represents.

Battery power gauge:

This shows the remaining battery power. It is divided into sections, each representing 20% of the total power. If three sections are filled, as in this example, this indicates that 60% battery power remains. If no battery is detected, a blank battery gauge marked with a flashing red X is displayed. If no data is available from the battery, a question mark is shown in the gauge.

Battery status/malfunction indicator:

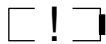
Normal battery function is indicated by the battery power gauge, together with the remaining operating time, on the Main Screen. You are informed of problems or changes in the status of the battery by the battery status/malfunction indicator. This consists of a blank battery gauge containing a symbol. If the symbol is red, this indicates a critical situation. You can check the specific cause of the problem by looking at the symbol(s) displayed in the **Battery Status** window.

Battery status indicator		Battery malfunction indicator	
	<p>Alternates with the battery gauge on the Main Screen.</p> <p>Check in the Battery Status window to see which status symbol is displayed to identify the cause.</p>		<p>The red ! flashes. Critical battery situation or malfunction. Check in the Battery Status window to see which malfunction indicator is displayed, or refer to the INOP, to identify the cause.</p>
			<p>Indicator for missing battery (flashing red X). An INOP is issued when the battery compartment is empty, and the MP2/X2 is connected to external power (a host monitor or the optional external power supply). This !! INSERT BATTERY INOP is suppressed for 15 seconds while the monitor is connected to AC mains power, allowing you sufficient time to load a new battery. After silencing, the INOP reappears every 10 seconds until a battery is loaded.</p>

Monitoring Time Available:

While the MP2/X2 is running on battery power, a time is displayed below the battery power gauge. No time is displayed when the MP2/X2 is running on external power via a host monitor or the external power supply (M8023A). This is the estimated monitoring time available with the current battery power. Note that this time fluctuates depending on the system load (the display brightness and how many measurements you carry out), the age of the battery, and the remaining capacity of the battery.

Battery Status Window

- ▶ To access the **Battery Status** window and its associated pop-up keys, select the battery status information on the Screen, or select **Main Setup -> Battery**.

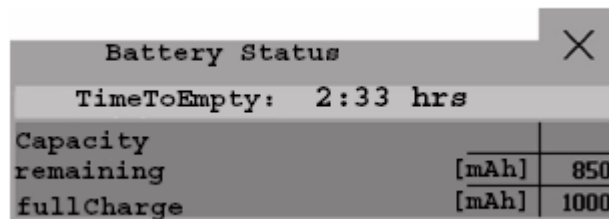

Battery Status		
TimeToEmpty: 2:33 hrs		
Capacity		
remaining	[mAh]	850
fullCharge	[mAh]	1000

Capacity, Remaining tells you how much power is left in the battery.









Capacity, Full Charge tells you how much power the battery can hold when fully charged.

Time To Empty tells you approximately how long you can continue to use the monitor with this battery. Note that this time fluctuates depending on the system load (the display brightness and how many measurements and recordings you carry out), the age of the battery, and the remaining capacity of the battery.

Time To Full is shown in place of **Time To Empty** if the MP2/X2 is connected to mains power via a host monitor or the M8023A external power supply, and tells you how much time is left until the battery is charged to 90%. Please allow indication to stabilize for 3 to 5 minutes after beginning the charging cycle. If the battery is charged over 90% **Battery Full (>90%)** is displayed until they are charged to 100%. Then **Batt Fully Charged** is displayed. You can use the M8043A Smart Battery Charger to charge the batteries externally.

Battery status/malfunction symbols:

If a problem is detected with the battery, an INOP may be issued, and the following symbols are displayed in the **Battery Status** window, where they may be accompanied by a battery status message providing more details. Messages appear in the line where **Time To Full/Time To Empty** is shown. Symbols indicating critical situations are colored red.

Battery status symbols		Battery malfunction symbols	
	battery is empty		(red) incompatible battery
	battery not charging as the temperature is above or below the specified range		(red) battery malfunction
	battery requires maintenance		(red) battery has no power left
	charging stopped to protect the battery		(red) battery temperature too high

Explanations of Battery Status and Malfunction Symbols:

Battery is empty: The remaining capacity of the battery is ≤ 10 min. Recharge the battery as soon as possible.

Temperature outside specified range: The charging of the battery is stopped if the temperature is below 10°C or above 60°C in order to protect the battery. Charging is resumed as soon as the temperature is within this range.

Battery requires maintenance: The battery requires conditioning. Refer to “Conditioning Batteries” for details.

Charging stopped to protect the battery: The charging of the battery is stopped to protect the battery if the temperature inside the monitor gets too high. Remove the battery and reinsert it or switch off the MP2/X2 if this situation occurs.

Incompatible Battery: The inserted battery is checked for certain battery internal parameters. If these are not correct, the incompatible battery symbol is displayed. Please use only M4607A batteries with the MP2/X2 monitor. Note that the incompatible battery symbol may also appear if there is a communication problem between the battery and the battery board.

Battery Malfunction: Communication between the battery and the battery board could not be established within about 4 minutes or battery internal data indicates malfunction. Please see the “Troubleshooting” section for remedies.

Battery has no power left: If the monitor is not running on AC power: battery will switch off power delivery at any moment - in this case recharge the battery immediately - or, if the monitor is running on AC power, the battery is in deep discharge and requires pre-charging to restore communication. To avoid this condition charge batteries to 50% for storage. Note that the battery malfunction INOP will eventually be issued if the pre-charging does not restore battery communication within about 4 minutes.

Battery Temperature too high: This symbol is displayed if the battery temperature goes above 65°C . In addition the INOP message CHECK BATT TEMP is displayed. If the battery temperature increases further above 70°C the batteries will switch off for safety reasons. Allow the battery to cool down to avoid the monitor switching off.

Viewing Battery Details

- ▶ To view detailed information for the battery, select the pop-up key **Batt**.

Batt	
Model	Philips M4607A
Chemistry	LiION
ManufactureDate	25 Feb 07
S/N	12345
Type	10.80V / 1000mAh
Request	12.60V / 1000mA
Cycles	5 (1%)

Printing Battery Status

To print all battery information in the **Battery Status** window,

8. Select the battery status information on the Screen or select **Main Setup** -> **Battery** to open the **Battery Status** window
9. Select the **Print Status** pop-up key to print the information on a connected printer.

Checking Battery Charge

- ▶ To check the charge status of a battery in a monitor, see the battery power gauge on the Screen or select **Main Setup** -> **Battery** to enter the **Battery Status** window.
- ▶ To check the charge status of a battery that is not connected to a monitor or battery charger, press the black dot marked “PUSH” on the labeled side of the battery. The remaining charge is indicated by four LEDs on the electronic fuel gauge directly above the dot. Each LED represents 25% of charge. If all LEDs are lit, the battery is fully charged, if only one LED is lit, 25% or less charge is left.

Replacing a Battery

To replace the battery,

1. Press the battery eject button. This releases the battery.

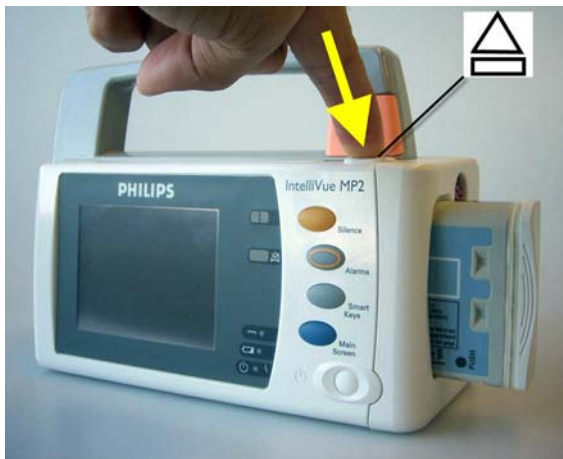

The INOP !! **INSERT BATTERY** is suppressed for 15 seconds, allowing you sufficient time to load a new battery.

2. Remove the battery from the compartment.
3. Slide the new battery into position with the contacts facing downwards. It should ‘click’ into position when it is fully inserted.

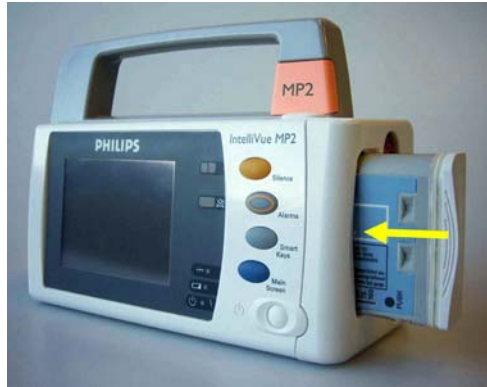

Optimizing Battery Performance

The performance of rechargeable batteries may deteriorate over time. Battery maintenance as recommended here can help to slow down this process.

Display Brightness Setting

- ▶ In the **Main Setup** menu, select **User Interface -> Brightness -> Optimum**. This selects a level of brightness suitable for most monitoring locations that uses less battery power than brighter settings.

Satisfy yourself that this level of brightness is suitable for your monitoring location.

Note that your monitor may be configured to dim or brighten the display brightness automatically when you disconnect from power, to suit the most common transport scenario (“**TransportBrightn**” setting).

Charging a Battery

A battery can be charged in a monitor during monitoring. You can also use the M8043A Smart Battery Charger to charge batteries.

1. Insert the battery into an MP2/X2 connected to a host monitor or the external power supply (M8023A) that is connected to mains power.
2. Charge the battery until it is full, the battery LED goes out, and the battery power gauge is filled.

In certain situations, internal temperature conditions may mean that the battery will not charge. This is sometimes necessary to protect the battery from damage, and does not indicate a malfunction. In this case you must use the M8043A Smart Battery Charger to charge the battery. To charge the battery in the smart battery charger, insert the battery into the battery adapter and then insert the battery with adapter into the smart battery charger.



Conditioning a Battery

What is Battery Conditioning?

Battery conditioning recalibrates the battery to ensure that it has accurate information on the actual battery capacity.

Why is Battery Conditioning Necessary?

The capacity of a battery decreases gradually over the lifetime of a battery. Each time a battery is charged its capacity decreases slightly. Therefore, the operating time of a monitor running on batteries also decreases with each charge cycle.

Battery conditioning ensures that the value stored in the battery for its full capacity takes account of this decrease, so that the remaining battery charge can be calculated accurately, and the low battery warning given at the right time.

When Should Battery Conditioning be Performed?

Battery conditioning should be performed when indicated by the Battery Status.

NOTE

When the battery status signals a conditioning request, the displayed **Time to Full** or **Time to Empty** may not be reliable.

What Causes the Conditioning Message on the Monitor?

In addition to the value for the full capacity, the battery also stores a value for the Max Error. The Max Error tracks the maximum possible deviation of the estimated charge of a battery from the actual charge.

If a battery is charged or discharged partially, or if it is charged while the monitor is being used, the accuracy of the “reference points” for the fully discharged and fully charged states decreases, causing an increase in the value for the Max Error (see diagram, below).

When the Max Error rises over a certain limit, a message is displayed prompting the user to condition the battery, as described in *Conditioning Batteries* (on page 106).

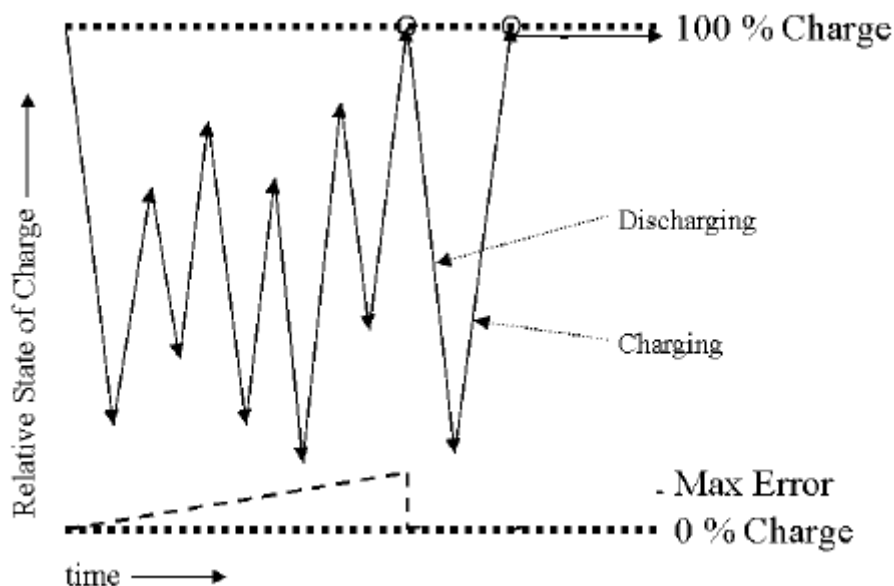

Conditioning Batteries

Battery conditioning can either be performed in the monitor or with an external battery charger. Philips recommends using the M8043A Smart Battery Charger to condition batteries.

Battery Conditioning in the Monitor

CAUTION

Do not use a monitor being used to monitor patients to condition batteries. The monitor switches off automatically when the battery is empty.

You should condition a battery when its “battery requires maintenance” symbol shows on the Screen. If conditioning is not performed immediately the monitor will still function according to specifications. However, the displayed time to empty and time to full will show increasing inaccuracy. Do not interrupt the charge or discharge cycle during conditioning. To condition a battery,

1. Insert the battery into an MP2/X2 connected to a host monitor or the external power supply (M8023A) that is connected to mains power.
2. Charge the battery until it is completely full. Open the **Battery Status** window. Check that the **Battery fully charged** message is displayed.
3. Disconnect the MP2/X2 from the external power supply (M8023A) or host monitor, and let it run until the battery is empty and the MP2/X2 switches itself off.
4. Reconnect the monitor to mains power or a host monitor and charge the battery until it is full for use or charge to 50% for storage.

Battery Conditioning with an External Charger

You can use the M8043A Smart Battery Charger for external battery conditioning. For details please see the IfU for the Smart Battery Charger. Use only the UL labeled M8043A Smart battery charger. To condition the battery in the smart battery charger, insert the battery into the battery adapter and then insert the battery with adapter into the smart battery charger.



Storing a Battery

A battery should not remain inside the monitor if it is not used for a longer period of time. Batteries should be charged to a maximum of 50% for storage.

NOTE

The battery will discharge over time if it is stored inside the MP2/X2 when not connected to AC power via a host monitor or the external power supply (M8023A). The reported values for “remaining capacity” and “runtime” will become less accurate when the battery is stored in this way for a longer period of time (that is, several weeks). Do not store the battery for more than 9 months without usage.

Battery Safety Information

WARNING

Use **only Philips batteries** part number M4607A. Use of a different battery may present a risk of fire or explosion.

Do not open batteries, or dispose of them in fire, or cause them to short circuit. They may ignite, explode, leak or heat up, causing personal injury.

Dispose of used batteries promptly and in an environmentally-responsible manner. Do not dispose of the battery in normal waste containers. Consult your hospital administrator to find out about local arrangements.

CAUTION

Do not disassemble, heat above 100°C (212°F) or incinerate the batteries, to avoid the risk of fire and burns. Keep batteries out of the reach of children and in their original package until you are ready to use them.

If battery leakage should occur, use caution in removing the battery. Avoid contact with skin. Refer to qualified service personnel.

After Installation, Testing or Repair

Before handing the patient monitor over to the end-user, make sure it is configured appropriately and that it is in monitoring mode. Ensure that the user receives the current revision of the monitor documentation.

Troubleshooting

Introduction

This section explains how to troubleshoot the monitor if problems arise. Links to tables that list possible monitor difficulties are supplied, along with probable causes, and recommended actions to correct the difficulty.

How To Use This Section

Use this section in conjunction with the sections *Testing and Maintenance* and *Parts*. To remove and replace a part you suspect is defective, follow the instructions in the section *Repair and Disassembly*. The *Theory of Operation* section offers information on how the monitor functions.

Who Should Perform Repairs

Only qualified service personnel (biomedical engineers or technicians) should open the monitor housing, remove and replace components, or make adjustments. If your medical facility does not have qualified service personnel, contact Philips' Response Center or your local Philips representative.

WARNING

High Voltage - Voltages dangerous to life are present in the instrument when it is connected to the mains power supply or to a host monitor. Do not perform any disassembly procedures (other than server removal) with power applied to the instrument. Failure to adhere to this warning could cause serious injury or death.

Replacement Level Supported

The replacement level supported for this product is to the printed circuit board (PCB) and major subassembly level. Once you isolate a suspected PCB, follow the procedures in the *Repair and Disassembly* section, to replace the PCB with a known good PCB. Check to see if the symptom disappears and that the monitor passes all performance tests. If the symptom persists, swap back the replacement PCB with the suspected malfunctioning PCB (the original PCB that was installed when you started troubleshooting) and continue troubleshooting as directed in this section.

Software Revision Check

Some troubleshooting tasks may require that you identify the Software Revision of your monitor. You can find the software revision along with other information, such as the system serial number, in the monitor revision screen. To access the monitor revision screen:

1. Enter the Main Setup menu and select **Revision**
2. Select **Product**
3. Select **Software Revision**
4. Select the pop-up key for the device you want to check (e.g. **M3002A**, **M8102A**)

NOTE

The part numbers listed in the monitor revision screen do not necessarily reflect the part numbers required for ordering parts. Please refer to the *Parts* section for the ordering numbers.

NOTE

The system serial number can also be found on the cover of the MSL connector.

Software Compatibility Matrix

For a detailed software compatibility matrix, please refer to the IntelliVue Compatibility Matrix on your Documentation DVD.

For further information on M3001A HW/SW compatibility, please refer to the *Parts* section.

Compatibility with MMS

The following table shows the compatibility between the monitor and X2 software revisions when X2 is used as an MMS.

Monitor Software	X2 Software	
	F.0	G.0
F.0	Yes	Yes
G.0	Yes	Yes

Compatibility with Information Center

The following tables show the compatibility between the MP2/X2/MP5 and the Information Center software revisions. The first table shows the compatibility if MP2/X2/MP5 are used as pure monitor or measurement module. The second table shows the compatibility if the MP2/X2/MP5 are used in companion mode i.e. as monitor and measurement module.

MP5/ MP2/X2 Software	Information Center Software								
	D.01	E.0	E.01	F.0	G.0	H.0	J.0	K.0	L.0
E.0	No	No	No	Yes	Yes	Yes	Yes	Yes	Yes
F.0	No	No	No	No	Yes	Yes	Yes	Yes	Yes
G.0	No	No	No	No	Yes	Yes	Yes	Yes	Yes

MP5/X2 Software	Information Center Software								
	D.01	E.0	E.01	F.0	G.0	H.0	J.0	K.0	L.0
F.0	No	No	No	No	No	No	No	Yes	Yes
G.0	No	No	No	No	No	No	No	Yes	Yes

Obtaining Replacement Parts

See *Parts* section for details on part replacements.

Troubleshooting Guide

Problems with the monitor are separated into the categories indicated in the following sections and tables. Check for obvious problems first. If further troubleshooting instructions are required refer to the Troubleshooting Tables.

Taking the recommended actions discussed in this section will correct the majority of problems you may encounter. However, problems not covered here can be resolved by calling Philips Response Center or your local representative.

Checks for Obvious Problems

When first troubleshooting the instrument, check for obvious problems by answering basic questions such as the following:

1. Is the battery adequately charged?
2. Is the AC power cord connected to the external power supply (M8023A) and plugged into an AC outlet?
3. Is the device properly connected to the external power supply or the host monitor?

NOTE

If the instrument is connected to a host monitor, refer to the host monitor's service manual for further troubleshooting instructions.

Checks Before Opening the Instrument

You can isolate many problems by observing indicators on the instrument before it is necessary to open the instrument.

NOTE

It takes several seconds for the AC Power LED on the monitor to switch on / off after the mains power cord has been connected / disconnected.

Checks with the Instrument switched Off

- external AC power connected, without battery:
 - AC Power LED on monitor is on (green).
- external AC power connected, with battery:
 - AC Power LED is on (green).
 - Battery LED is off if battery is fully loaded, yellow if battery is being charged.
 - Battery LED red and blinking signals battery or charger malfunction. See *Battery-related problems*.
- No external AC power connected, with battery:
 - All LEDs are off.

Checks with the Instrument switched On, external AC power connected, with battery

When the monitor is first switched on the AC Power LED switches on and stays on. The Power On/Error LED lights up red and then switches to green and stays on.

Checks with the Instrument switched On, external AC power not connected, with battery

When the monitor is connected to external AC power, the Power On/Error LED lights up red and then switches to green and stays on.



No.	Description
1	External Power LED (Green)
2	Battery LED (Red/Yellow)
3	Power On/Standby & Error LED (Green/Red)

Initial Instrument Boot Phase

The following tables describe the regular initial boot phase of the monitor and its components. If the boot phase does not proceed as described below go to Boot Phase Failures for Troubleshooting information.

Monitor Boot Phase:

For these steps it is assumed that the Monitor is powered correctly and the +3,3 V System Board supply voltage is okay. This is indicated by the green Power On LED.

Time (sec.) after Power On	Event
0	When the Power On/Off button is pressed, the combined Power On and Error LED switches on immediately and is red.
3	The alarm LEDs are switched on with low intensity. Colors: Left LED:blue; Right LED:red; Alarm Suspend LED (bottom): red. Power On/Error LED switches to green.
6	Boot Screen with the Philips Logo appears on the display.

Time (sec.) after Power On	Event
7	Test Sound is issued.
10	Alarm LEDs are tested in the following sequence: Blue on-off (left LED only) Yellow on-off (left & right LED) Red on-off (all LEDs)
	Boot Screen with the Philips Logo disappears
	Fixed screen elements (for example alarm fields) appear on the screen.
15-30	First measurement information appears on the screen, touchscreen is functional

Troubleshooting Tables

The following tables list troubleshooting activities sorted according to symptoms. Click on the links below to view a particular table.

NOTE

Be sure to check all cable connections within the monitor before proceeding to further troubleshooting.

How to use the Troubleshooting tables

The possible causes of failure and the remedies listed in the troubleshooting tables should be checked and performed in the order they appear in the tables. Always move on to the next symptom until the problem is solved.

Boot Phase Failures

Display is blank (on page 117)

Touch Operation not functioning (on page 118)

General Monitor INOP Messages (on page 119)

Battery related problems

Bedside Network Status Icons (on page 121)

Network related problems

IIT-related Problems (on page 123)

Alarm Lamps

Alarm Tones

Individual Parameter INOPs (on page 128)

Printer

Troubleshooting the ECG Sync Pulse (on page 129)

Companion Mode Problems (on page 129)

Boot Phase Failures

Symptoms	Possible Causes of Failure	Failure Isolation and Remedy
External Power LED does not light up when connected to external power or host monitor	External Power Connection not ok	Check that the external power sources are powered and the power cord and the MSL cable are ok and connected
	External power supply or power cable defective	Exchange external power supply or power cable
	MSL cable defective	Exchange MSL cable
	Flex cable to HIF board not connected correctly	Check flex cable connection to HIF board
	Flex cable to HIF board defective	Exchange flex cable to HIF board
	HIF board defective	Exchange display assembly
	MSL Power board defective	Exchange MSL power board
Combined Power On/Error LED remains off after pressing power on button:	Main Board defective	Exchange Main Board
	Battery defective	Check battery and replace, if necessary
	Flex cable to HIF board not connected or not positioned correctly.	Check flexible cable connection to HIF board and display
	Flex cable to HIF board defective	Exchange flex cable to HIF board
	HIF board defective	Exchange display assembly
	IIT module defective integrated measurements defective NBP pump defective	Disconnect cables and boards: - IIT module - Measurement Block - NBP pump then try to switch on the monitor again.
	MSL Power Board defective	Exchange MSL Power Board and try to switch the monitor on again.
Red Power On/Error LED stays on continuously	Main Board defective	Exchange main board. Add boards in reverse order and try again with each board.
	IIT module defective integrated measurements defective NBP pump defective MSL Power Board defective	Disconnect cables and boards: - IIT module - Measurement Block - NBP pump - MSL power board then try to switch on the monitor again.

Symptoms	Possible Causes of Failure	Failure Isolation and Remedy
Red Power On/Error LED blinks (indicating cyclic reboots)	Software Fault	connect Support Tool directly to host monitor with crossover cable and start “scan for defective devices” If the Support Tool can detect the device and it indicates the Operating Mode is ‘Boot’, download and store the status log. Reload software and re-clone the monitor. If this fixes the problem e-mail the status log to your local response center
	Hardware Failure	If no device is detected by the support tool or if reloading the software does not fix the problem, proceed as described above in section “Red error LED stays on continuously”
Alarm LEDs remain off:	Flex cable to HIF board not connected or not positioned correctly	Check flex cable connection to HIF board.
	HIF board defective	Exchange display assembly
	Flex cable to HIF board defective	Exchange flex cable
	Main board defective	Exchange Main board
No Test Sound issued	Speaker not connected	check for INOPs and follow instructions check speaker connection
	Speaker defective	exchange speaker
	Main board defective	exchange main board

Display is blank

Symptoms	Possible Causes of Failure	Failure Isolation and Remedy
Display is blank (The information listed in this table is only valid if the boot phase has completed without error. See Boot Phase Failures table for a description of the Boot phase.)	Flex cable to display not connected	Check flex cable connection to display.
	Display assembly defective	Replace display assembly
	Main board defective	Replace main board

Touch Operation not functioning

Symptoms	Possible Causes of Failure	Failure Isolation and Remedy
Touch Screen not functioning	Touchscreen functionality has been temporarily disabled	Check if touchscreen functionality has been temporarily disabled (“Touch disabled, press Main Screen” appears on the screen). If yes, press and hold the Main Screen key to re-enable touchscreen operation.
	Previously stored touch calibration is lost.	Calibrate touch (initial) using the support tool.
	Flex cable to display defective or not positioned/connected correctly	Check flex cable connection to display
	Main board defective	Replace main board

Symptoms	Possible Causes of Failure	Failure Isolation and Remedy
Touch Position invalid	Touch not calibrated	Perform touch calibration: 1. Enter Service Mode 2. Enter the Main Setup Menu 3. Select Hardware 4. Select Touch Driver Settings 5. Select Calibrate or use the support tool to calibrate touch screen

General Monitor INOP Messages

INOP Message	Possible Causes of Failure	Failure Isolation and Remedy
CHECK MONITOR FUNC	Problem with too low voltages (5V, 12V) in the monitor. Alarm lamps, display or interfaces may not function correctly.	Disconnect cables of: - all measurement boards - IIT - NBP Pump and reconnect them one at a time to isolate any defective board.
	Main board defective	Replace the main board
CHECK MONITOR TEMP	The temperature inside the monitor is too high	Check the environment for possible causes
	Battery temperature is too high	Check the battery.
	Main Board defective	replace Main Board
SETTINGS MALFUNCTION	Problem during cloning process.	Reclone configuration file
	Memory space in which the settings are stored has been corrupted	Reclone configuration file. This will reload the memory space.
	Main board defective	Replace Main board











Battery related problems

Symptoms	Causes of Failure	Failure Isolation and Remedy
BATT EMPTY INOP tone, battery LED flashes During this INOP, alarms cannot be paused or switched off.	The estimated remaining battery-powered operating time of the battery is ≤ 10 minutes.	Insert full battery or recharge the battery immediately. If the condition persists, this INOP is re-issued two minutes after you acknowledge it.
BATT INCOMPAT INOP tone	The indicated battery cannot be used with this monitor.	Replace with the correct battery (M4607A).
	Communication problem between power board and main board.	Check battery in a different monitor. If INOP persists replace battery. Check MSL power board using a known good battery. If INOP persist, replace MSL power board.
BATT LOW INOP tone	The estimated battery-powered operating time remaining is less than 20 minutes.	Insert full battery or recharge the battery
BATT MALF INOP tone, battery LED flashes During this INOP, alarms cannot be paused or switched off if the monitor is not connected to AC power.	The monitor cannot determine the battery status or there is a communication problem between the battery and the main board.	Replace the faulty battery. If the condition persists and the monitor is not connected to external power, this INOP is re-issued two minutes after you acknowledge it. Check the battery in a different monitor or in a battery charger. If the INOP persists the battery is faulty. Check the power board with known good battery. If the INOP persists, replace power board. If the problem persists, replace main board.

Symptoms	Causes of Failure	Failure Isolation and Remedy
CHARGER MALFUNCTION INOP tone, battery LED may flash	There is a problem with the battery charger in the monitor.	Switch the monitor off and back on again. If the problem persists replace battery with known good battery. If the INOP is shown again replace the power board. If the problem persists replace the main board.
CHECK BATT TEMP INOP tone	The temperature of the battery is too high.	Check that the monitor is not exposed to heat.
!!! INSERT BATTERY INOP tone	The monitor is connected to AC Mains without a battery fully inserted. Battery is required for sealing the battery compartment.	Insert a battery into the battery compartment.

Bedside Network Status Icons

The following table shows the icons displayed on the monitor when network related issues occur.

Wireless Icon	Wired Icon	Inverse Video	Blinks	Icon Comments	Inop Message	What does it mean?
No icon	No icon	-	-	-	-	MONITOR does not have a LAN connection (Wireless MONITOR cannot find an access point to talk to, wired MONITOR cannot hear anything on its LAN connection)
		Yes	Yes	Central - outline only	"UNSUPPORTED LAN" (after 1 minute)	MONITOR has a LAN connection but does not have an IP address assignment (Wireless MONITOR has found an access point to talk to, wired MONITOR hears traffic on the LAN)
		No	No	Central - outline only	"NO CENTRAL MONITORING"	MONITOR is connected to the LAN and has an IP address assignment, but the bed is not being monitored at the central 1. MONITOR is not assigned to a sector 2. There is another monitor on the network with the same "Equipment Label"
		No	No	Central - solid box	-	Normal Operation - MONITOR assigned to a sector and is being monitored by a central
-		No	No	Central - solid box, network line extended	-	Normal Operation - MONITOR assigned to a sector and is being monitored by a central This monitor also has OVERVIEW functionality on other beds
	-	No	Yes	Central - solid box	"WIRELESS OUT OF RANGE"	Wireless MONITOR that currently is being monitored by a central is losing contact with the access point and cannot find another to talk to
		Yes	Yes	Central - outline only, line for broken connection to central	"NO CENTRAL MONITORING"	Monitor lost connection to the Information Center: 1. LAN cable was disconnected 2. Information Center was disconnected 3. Network infrastructure failure (switch, etc.) 4. Out of range (wireless MONITOR)

Network related problems

Symptoms	Possible Causes of Failure	Failure Isolation and Remedy
Prompt Message “no central assigned to this bed” is issued	The monitor label is not set in the monitor (if the beds are “monitor labeled” in the IntelliVue Information Center (IIC))	Set Monitor Label in Config Mode
	Problem with the IntelliVue Information Center (IIC) to Switch communication (if the beds are “port mapped” in the IntelliVue Information Center (IIC))	Check IntelliVue Information Center (IIC) to Switch communication, Switch configuration and Firmware status
INOP “Unsupported LAN” is issued. One of the following icons is displayed.	Network failure	Check if network switches, IntelliVue Information Center (IIC) and Database Server are all running and connected to the network
	Monitor connected to wrong network	Check if monitor has been connected for example to a different hospital network instead of the Philips Clinical Network
	IP address conflict after infrastructure re-installation	Reboot Database Server and IntelliVue Information Center (IIC)
No connectivity to IntelliVue Information Center (IIC), no prompt or error message on monitor	Hardware Defect	Check LAN cable connection
		Check power board in monitor and the external power supply.
		Check network switch
	Configuration problem	Check switch configuration and firmware revision

IntelliVue 802.11 Bedside Adapter Problems

Symptoms	Cause of Failure	Failure Isolation and Remedy
No Network icon or Network icon flashes. No association to central station.	Configuration problem.	Make sure that the Mode, SSID, Country and Security settings in the Setup WLAN menu match your installation
	Communication problem between the monitor and the IntelliVue 802.11 Bedside Adapter or RSSI value below 30.	<p>Ensure that the network infrastructure is functioning properly. See Troubleshooting tables in the IntelliVue 802.11 a/g Infrastructure Installation and Configuration Guide for details.</p> <p>Check the antenna cable connection between the IntelliVue 802.11 Bedside adapter and the antenna.</p> <p>Check the cable connection between the IntelliVue 802.11 Bedside Adapter and the system interface board.</p> <p>Replace cable, antenna, antenna cable or IntelliVue 802.11 Bedside Adapter if necessary.</p>

IIT-related Problems

Symptoms	Cause of Failure	Failure Isolation and Remedy
No Network icon or Network icon flashes. No association to central station.	Incorrect RF Access Code. No IP Address.	Check that RF Access Code is set correctly. Make sure that network is set up correctly.

Symptoms	Cause of Failure	Failure Isolation and Remedy
INOP “Unsupported LAN” is issued	Communication problem between the monitor and the IIT adapter. MAC Instr. Tele. field in Instrument Telemetry Service Window is 0000 0000 0000	<p>Check that RF Access Code is set correctly and the network is correctly set up.</p> <p>Check the connection between the main board and the IIT module.</p> <p>Check the antenna cable connection between the IIT module and the antenna.</p> <p>Replace antenna, antenna cable or IIT module if necessary.</p>

Telemetry Device related Problems (TAAP)

Symptoms	Cause of Failure	Failure Isolation and Remedy
TELE DISCONNECTED INOP message is issued	The SRR link between the telemetry device and the monitor is disrupted.	<p>Position the SRR device and the monitor closer to each other. Check SRR signal quality indicator for signal strength.</p> <p>Check SRR Configuration Settings.</p> <p>Alternatively, use the TAAP cable connection between the telemetry device and the monitor.</p>
INVALID LEADSET INOP message is issued	see the instructions supplied with the telemetry device	see the instructions supplied with the telemetry device
REPLACE BATTERY T or BATTERY LOW T INOP message is issued	no battery is inserted in the telemetry device or the battery is low.	insert/replace the battery in the telemetry device. Note: If you are using the SRR connection, you must silence the INOPs even when the battery has been replaced. For further details see the instructions provided with the telemetry device.

Symptoms	Cause of Failure	Failure Isolation and Remedy
TELE EQUIP MALF INOP message is issued	no stable connection between the telemetry device and the monitor	Disconnect and reconnect the telemetry device from the monitor. Remove and reinsert the battery in the telemetry device. If problem persists, replace the telemetry device.
Telemetry Device using SRR not recognized by the monitor.	Telemetry Device not supported by the SRR adapter	Make sure you use a telemetry device which is compatible with SRR.

Short Range Radio Interface Problems

Symptoms	Cause of Failure	Failure Isolation and Remedy
Measurement selection icon does not change to SRR.	Assignment of SRR device to monitor not possible	Check SRR Configuration Settings. Replace defective SRR interface or cable, if necessary. Make sure SRR interface is installed.
	SRR interface of telemetry transceiver defective or incompatible	Make sure the telemetry transceiver SRR interface is compatible and functional.
Measurement selection icon changes to SRR but Assignment of SRR device to monitor fails. SRR INTERFERENCE INOP is issued	RF Interferences	Check location for RF interferences and free frequencies by performing a site survey (e.g. with air magnet tool).

Symptoms	Cause of Failure	Failure Isolation and Remedy
Communication Dropouts or gaps in parameter waves. SRR INTERFERENCE INOP may be issued	RF Interferences	Check location for RF interferences and free frequencies by performing a site survey (e.g. with air magnet tool).
	Too many SRR devices allocated to one SRR channel	Up to two SRR connections can be established per channel. Check SRR Configuration Settings.
SRR communication aborted. SRR INTERFERENCE or SRR INVALID CHAN INOP may be issued.	RF Interferences	Check location for RF interferences and free frequencies by performing a site survey (e.g. with air magnet tool).
	Too many SRR devices allocated to one SRR channel	Up to two SRR connections can be established per channel. Check SRR Configuration Settings.
	SRR device out of range (either monitor or Telemetry Transceiver)	Position the SRR devices closer to each other. Check SRR signal quality indicator for signal strength.
Telemetry Device using SRR not recognized by the monitor.	Telemetry Device not supported by the SRR adapter	Make sure you use a telemetry device which is compatible with SRR.

Alarm Lamps

Symptoms	Possible Causes of Failure	Failure Isolation and Remedy
INOP Message Check Alarm Lamps is issued	Flex cable to HIF board not connected or not positioned correctly	Check Flexible Display cable connection to main board and display
	HIF board defective	Replace display assembly
	Main board defective	replace Main board

Symptoms	Possible Causes of Failure	Failure Isolation and Remedy
Alarm occurs, but no LED lights up	Environmental lighting too bright	Place monitor in a darker environment
	Flex cable to HIF board not connected or not positioned correctly	Check Flexible Display cable connection to main board and display
	Flex cable to HIF board defective	Exchange flex cable
	HIF board defective	Replace display assembly
	Main Board defective	Main board

Alarm Tones

Symptoms	Possible Causes of Failure	Failure Isolation and Remedy
INOP Message SPEAKER MALFUNCTION is displayed	Speaker cable disconnected	Reconnect speaker cable
	Speaker assembly defective	Replace speaker assembly
	Sound amplifier on main board defective	Replace main board
Alarm occurs but no alarm sound is issued	Audible alarm indicators have been switched off	Switch audible alarm indicators back on
	Volume set to 0	Increase volume
	Speaker defective	Replace speaker
	Sound amplifier on main board defective	Replace main board
Alarm sound too quiet	Speaker foil defective.	Exchange monitor housing.

Alarm Behavior

If your monitor did not alarm in the way in which the end user expected, please consult the Instructions for Use for possible setup issues or configuration settings which could affect alarm behavior.

Individual Parameter INOPs

If any of the following parameter INOP messages are issued check the connection from the measurement to the main board. If the INOP messages persist replace the respective measurement. If problem persists, replace the main board and/or the power board.

- CO2 EQUIP MALF
- ECG EQUIP MALF
- NBP EQUIP MALF
- <Pressure Label> EQUIP MALF
- RESP EQUIP MALF
- SpO₂ EQUIP MALF
- SpO₂ TRANSDUC MALF
- <Temp Label> EQUIP MALF

Printer

Symptoms	Cause of Failure	Failure Isolation and Remedy
Prompt message “Print job could not be queued” is issued. No print device is found.	Printer is disabled in the Setup Printers menu Paper size of printer does not match paper size of report	Enable the correct printer in the Setup Printers menu Change paper size of the printer in the Setup Printers menu or change paper size of the report in the Setup Reports menu.
Status message “Print device Remote 1 (Remote 2, Remote 3) unavailable” is issued. Printer job is stalled	Print error on IntelliVue Information Center (IIC) Network Connection to IntelliVue Information Center (IIC) not functioning	Print a test report on the IntelliVue Information Center (IIC). If this fails, refer to IntelliVue Information Center (IIC) documentation Check that the network connection between the monitor and the IntelliVue Information Center (IIC) is working
Status message “Printing on device Remote 1... (Remote 2, Remote 3)” is issued but no report is printed	Print queue on IntelliVue Information Center (IIC) is full. Reasons for this may be: - Printer is not switched on - Printer paper tray is empty	Switch on printer power Fill printer paper tray

Symptoms	Cause of Failure	Failure Isolation and Remedy
Printouts are not as expected	Printer paper size is not correctly configured	Configure the paper size according to the inserted print media
	Printer resolution is not correctly configured	Configure the printer resolution according to the printer capabilities
	Printer color support is configured to “On” although the printer does not support color	Configure the printer color support to “Off”
	Printer not compatible	Check specifications

Troubleshooting the ECG Sync Pulse

Symptoms	Cause of Failure	Failure Isolation and Remedy
No ECG Sync Pulse	Wrong or defective cable	Make sure you are using the correct cable
	No ECG pulse signal available	Measure ECG Pulse out with oscilloscope.
	ECG OUT connector assembly not connected	Check ECGOUT connector assembly
	ECG connector defective	Replace ECG connector
	Main board defective	Exchange main board

Companion Mode Problems

Symptoms	Cause of Failure	Failure Isolation and Remedy
X2 does not enter companion mode when connected to a host monitor	Incompatible software revision of host monitor	Make sure that the host monitor has software revision F.0 or higher.
	MSL connection not established correctly	Check MSL connection to host monitor
	MSL power board defective	Exchange MSLpower board
	Main board defective	Exchange Main board

Symptoms	Cause of Failure	Failure Isolation and Remedy
	MSL on host monitor defective	See troubleshooting section in the host monitor's service guide

Image Sticking

If a static image is displayed for a long time on an LCD display, image sticking, i.e. a temporarily retained image, may occur. To eliminate image sticking, switch off the display and switch it back on again. It is also recommended to use the moving image in standby mode.

Status Log

Many events that occur during start-up or regular monitoring are logged in the Status Log. The Status Log can be printed and cleared. Not all entries in the Status Log are errors.

Monitor				
H	1720	20050	1	4 Apr 02 16:37
C	1721	21050	1	4 Apr 02 15:37

The Status Log window shows logged events which caused a reboot of the system component (monitor or measurement block).

To enter the Status Log Window, select Main Setup -> Revision. The following list opens up:

- Status Log
- Product
- Appl. SW
- Config
- Boot
- Language

Select **Status Log**.

The first column in the log identifies the event class ("C": caused a cold start, "H": caused a hot start, "N": no restart, for information only). Column 3 and 4 identify the event source and event code. Column 4 counts the number of occurrences of the event. The last column shows the time and date of the last occurrence of the event.

Cold Start: A cold start erases patient data incl. ADT, trends and customer configuration settings.

Hot Start: A hot start is a system reset. No data is erased.

The following pop-up keys overlay the SmartKeys:

Clear StatLog			M8102
------------------	--	--	-------

Clear StatLog

This key clears the currently displayed Status Log

M8102/M3002

NOTE

This key switches to the Monitor Revision Window

If an event occurs repeatedly, contact your Philips Service Representative.

NOTE

It is possible, using the support tool, to download the status log and send it to your Philips Service Representative as a file (for example via e-mail).

List of Error Codes

There are no error codes at this point.

Troubleshooting with the Support Tool

Using the support tool you can:

- access the full status log which can be saved as a file
- reload software
- identify defective devices
- reset touch screen calibration

For details on how to perform these tasks see the Support Tool User Manual.

Troubleshooting the Individual Measurements or Applications

For problems isolated to an individual parameter or application, please consult the Instructions for Use and configuration information.

If you are getting questionable readings for individual measurements you may want to do the Performance Verification tests in the *Testing and Maintenance* section.

The performance of the individual applications (arrhythmia, trending) are affected by the configuration of the monitor. When contacting Philips support you may be asked about the configuration of the monitor to aid in troubleshooting.

Repair and Disassembly

The following section describes the disassembly and reassembly procedures for the monitor and its components.

Who Should Perform Repairs

Only qualified service personnel (biomedical engineers or technicians) should open the monitor housing, remove and replace components, or make adjustments. If your medical facility does not have qualified service personnel, contact Philips' Response Center or your local Philips representative.

WARNING

High Voltage - Voltages dangerous to life are present in the instrument when it is connected to the mains power supply. Do not perform any disassembly procedures (other than server removal) with power applied to the instrument. Failure to adhere to this warning could cause serious injury or death.

Tools required

- Torx screwdrivers (sizes 8, 20)
- Small flat head screwdriver
- 1 small Pozi or Philips head screwdriver
- Needle Nose Pliers
- ESD mat and wrist strap
- Cleaning Agent

Recommended cleaning agents are:

Tensides (dishwasher detergents)	Edisonite Schnellreiniger ^â , Alconox ^â
Ammonias	Dilution of Ammonia <3%, Window cleaner
Alcohol	Ethanol 70%, Isopropanol 70%, Window cleaner

Removing the Battery

1. Press the battery release button and remove the battery.

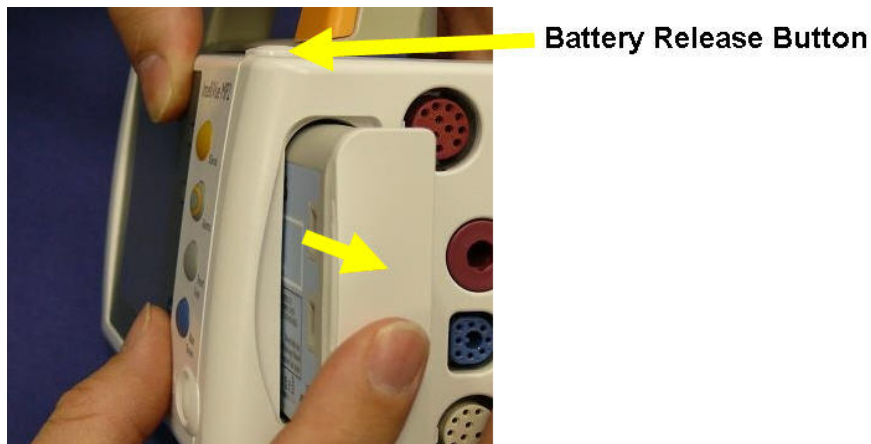

Removing the Handle

1. Remove the gray cover from the handle. You may need a screwdriver to help you remove the cover. Then remove the screw beneath (T20).



2. Lift up the handle and remove it.



Reassembly Note: When reassembling the handle, make sure it is inserted correctly into its notch. If an exchange handle is required, be sure to insert the new branding cover into the handle



Removing the Side Cover

1. Position the thin-bladed screwdriver in the small slot provided for this purpose. Then push off the side cover. A click signals that the cover has been removed from its position.



NOTE

There may be a slight resistance when removing the side cover.

Removing the Display/Exchanging the SRR Board

NOTE

The Short Range Radio (SRR) board is part of the display assembly and cannot be exchanged separately. To exchange the SRR board, the whole display assembly needs to be replaced.

1. Remove the battery as described above.
2. Remove the handle as described above.
3. Remove the side cover as described above.
4. Position the MP2/X2 with the connectors facing towards you. Locate the heads of the two pins on the display side. Remove these by lifting them out gently with a thin-bladed screwdriver and then pulling them out manually.



- Open up the display by lifting it up gently. The display is connected to the device with two thin flex cables. Handle these with care. There may be a slight resistance due to rubber sealing.

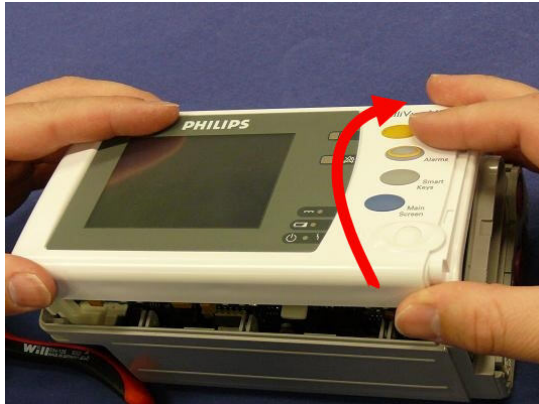

- The flex cables are secured with two latches that open in opposite directions. **Be very careful when opening the connectors - a broken latch cannot be replaced!** The photo below shows the latches in open position. See steps 7 and 8 for details on how to open the latches.

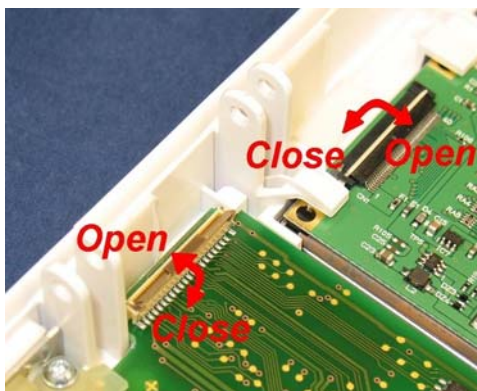

- Lift up the white latch and release the display cable.

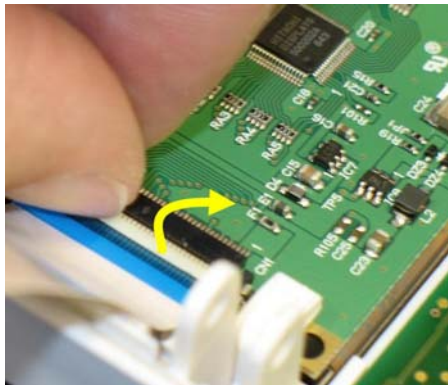

TIP

Use your fingernail to lift up the latch.

8. Remove the HIF cable by lifting up the brown latch.

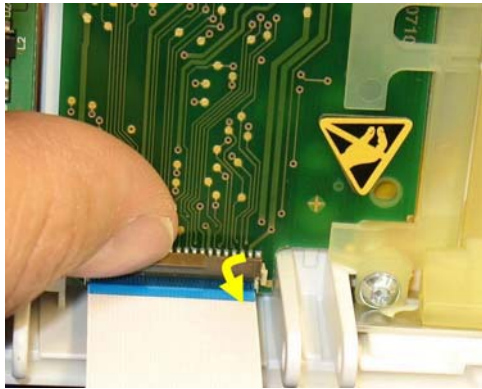

Reassembly of the Display

1. Insert the display and HIF cables into the open connectors. Make sure the display cable is placed under the metal nose and is properly aligned with the connector.

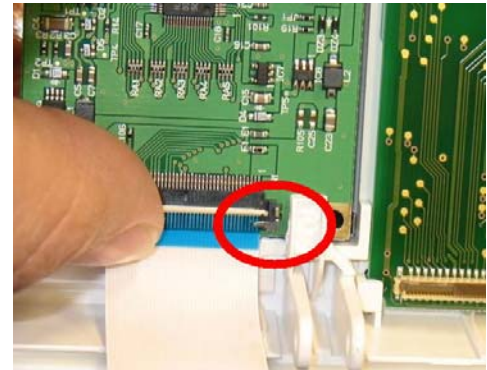
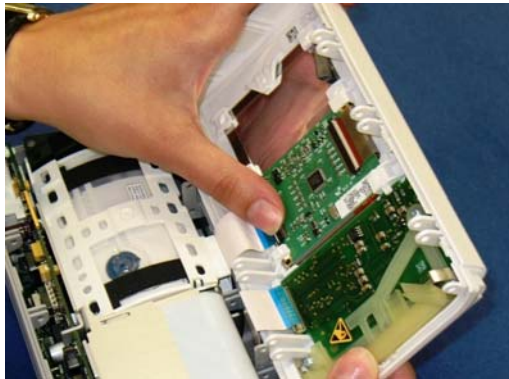

2. **Close the latches very carefully. A broken latch cannot be replaced.** When you hear a click, the latch is locked. Assume that the cables are seated correctly by pulling them slightly. The cables should remain in their position.
3. For reassembly of the display and pins, perform steps 1-6 of the section **Removing the Display** in reverse order.

Removing the NBP Pump Assembly

1. Remove the battery as described above
2. Remove the handle as described above
3. Remove the display as described above

- Remove the IIT antenna cable (if installed) from the NBP holder as shown below.

**TIP**

The antenna cable can also be loosened when the NBP pump assembly is lifted up (see Step 6)

- Remove the screws (T8) securing the NBP assembly.

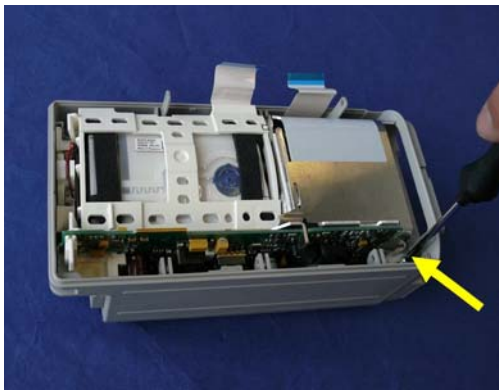

- Position your hands as shown below to loosen the connection to the main board. Then lift the whole NBP pump assembly up, including the metal chassis (battery compartment).

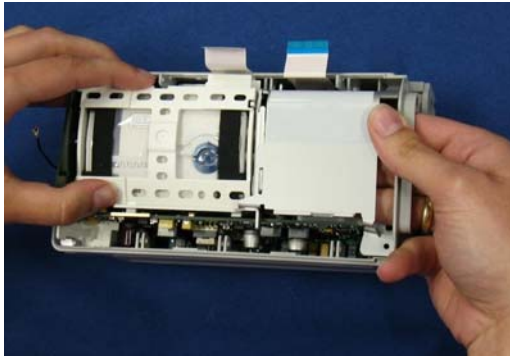
**TIP**

The connection between the NBP flex and the main board may be tight. This is the only connection which needs to be loosened.

- Lift the NBP cage up and remove it with the release mechanism as shown below.

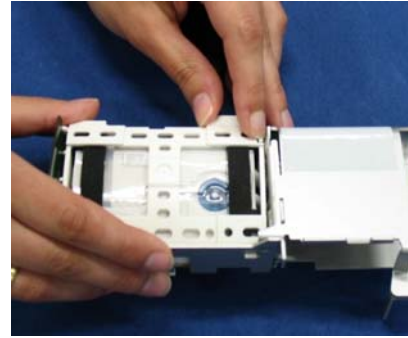
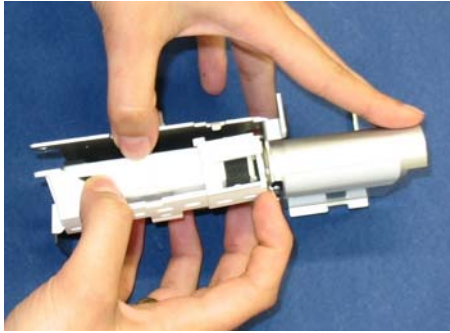

8. Remove the IIT antenna from the NBP cage.

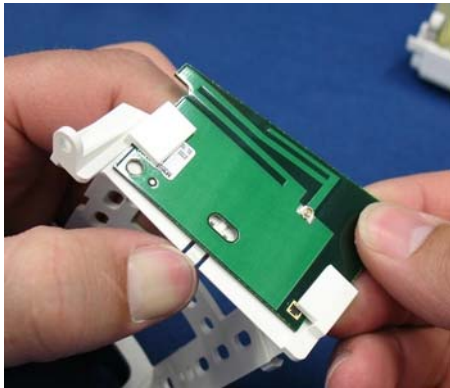

Reassembling the NBP pump chassis

1. Make sure the NBP flex holder is positioned correctly (i.e. pushed all the way up).

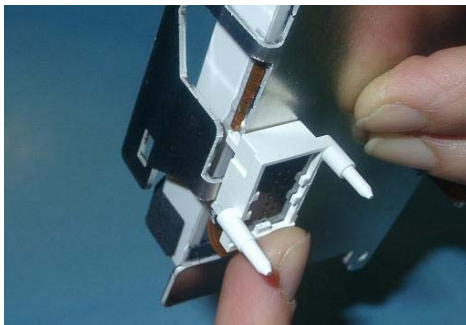

2. Make sure the silicon tubes are still attached to the airguide and that they are seated correctly. Check that the connection to the NBP connector is firmly established.

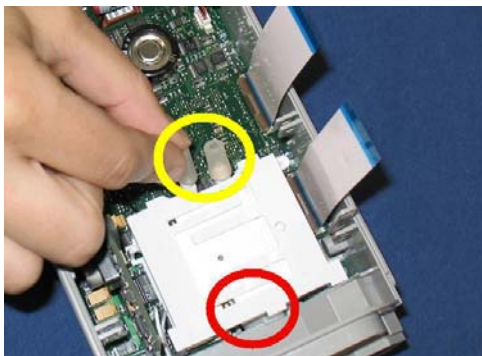

3. Insert the NBP pump assembly and press it down carefully. Check that the battery compartment and housing are in line with each other. The NBP flex connector is guided by plastic posts on the flex holder to ensure proper connection to the main board.



4. Make sure the NBP pump is connected properly to the NBP air guide tubes by lifting the back of the pump up and pressing it forward to establish a tight connection.

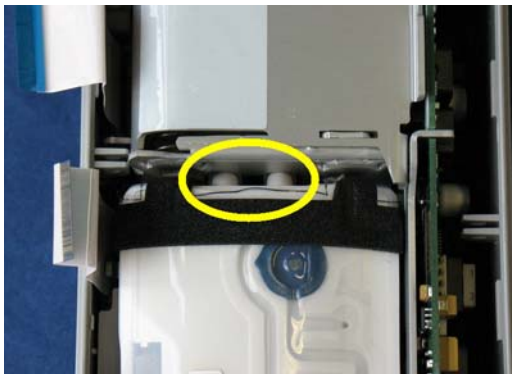
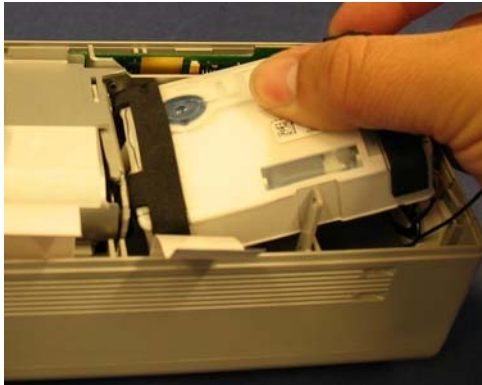

- Hook the NBP pump holder into the metal chassis and press it down gently. Make sure you do not squeeze the display cable in between. Press down until the latch has clicked into its position. Then connect the IIT antenna cable to the IIT antenna board

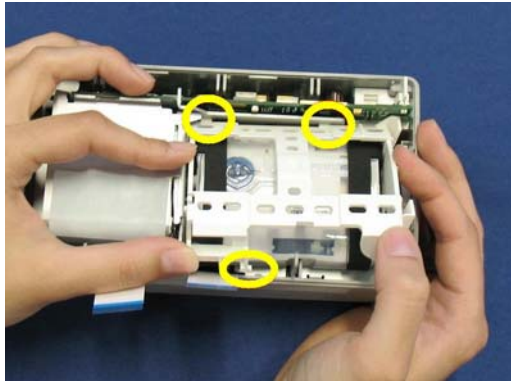

- Secure the NBP pump assembly with two screws. For adjustment reasons, start with the screw on the battery side.

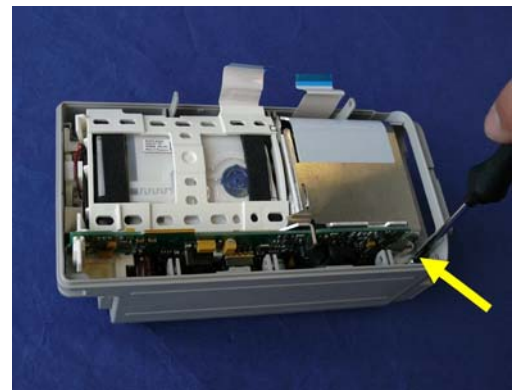
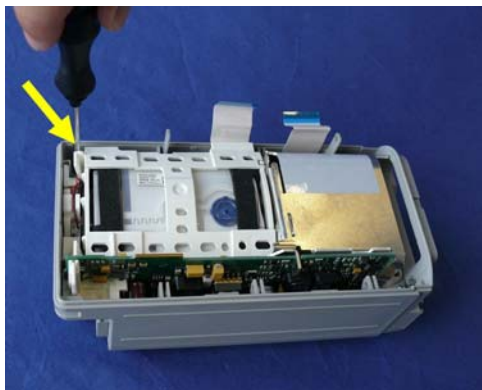

Exchanging the NBP Pump

- Remove the battery as described above.
- Remove the handle as described above.
- Remove the display as described above.
- Remove the NBP pump assembly as described above.
- Detach the flex holder from the metal chassis by pushing it down as shown below.



6. Remove the pump from the metal chassis.

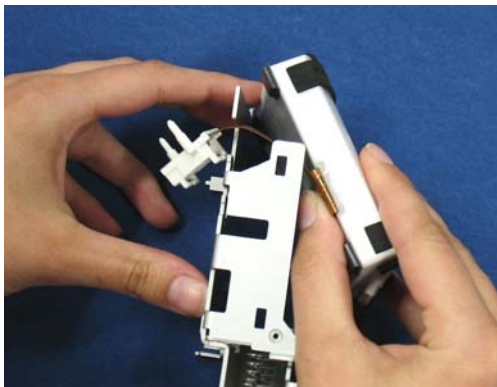

7. Remove the flex holder from the NBP flex cable by pressing down the cable with your thumb and then pulling it out. The flex cable is fixed by a small plastic latch on the flex holder. By pressing down the flex cable, the mechanism is released.

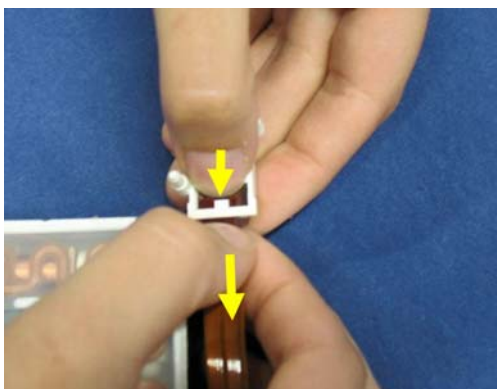

8. Insert the new pump and/or flex holder. Bend the NBP flex cable as shown in the picture. Remove the silicon tubes from the pump for later assembly.

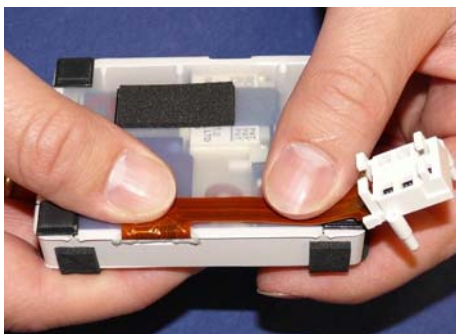

9. Insert the pump into the metal chassis. Start with the flex as it is shown in the picture.

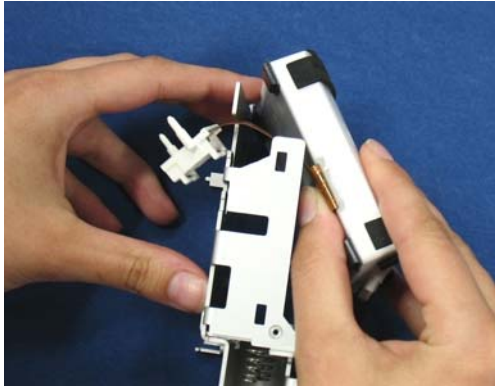

10. Press the pump flat to the metal chassis and make sure that the flex is not creased.

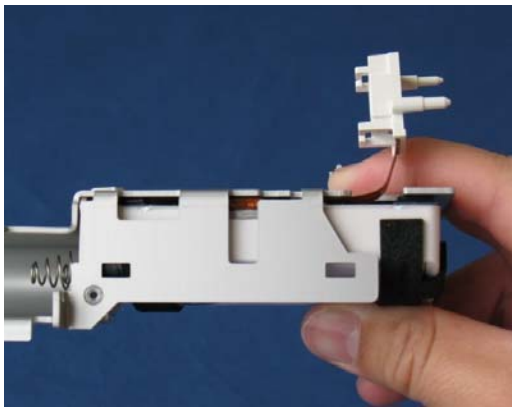

11. Mount the NBP flex holder into the metal chassis



12. Make sure the silicon tubes are still attached to the airguide and that they are seated correctly.

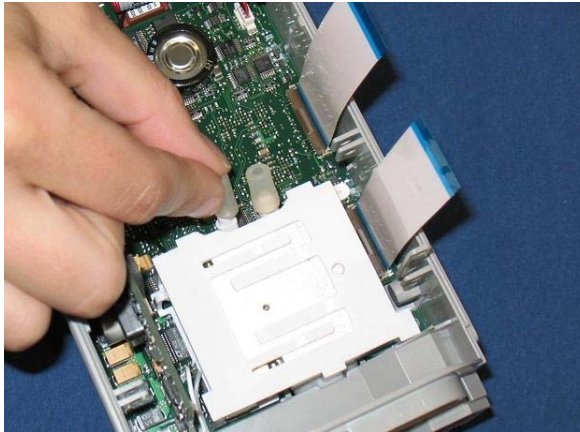

13. Reassemble the NBP pump assembly as described above.

Exchanging the NBP Airguide / IIT or WLAN Assembly

1. Remove the battery as described above.
2. Remove the handle as described above.
3. Remove the display as described above
4. Remove the NBP pump assembly as described above.
5. Remove the IIT or WLAN antenna from the IIT or WLAN antenna board.
6. Position the antenna as shown below.



7. Remove the entire airguide cage. Separate the two halves of the airguide cage for later reassembly.



8. Open the plastic cage. Disassemble the boards if IIT or WLAN is installed.

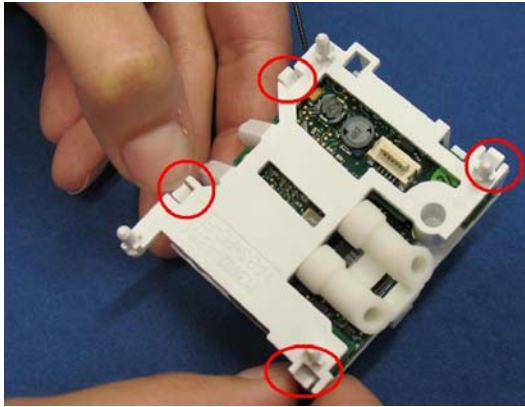

9. Disassemble the radio module.

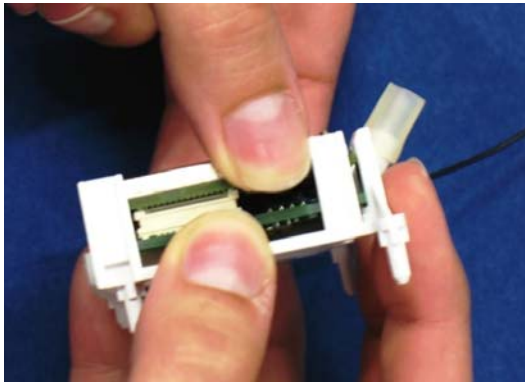

10. Remove the IIT system board or WLAN adapter board..

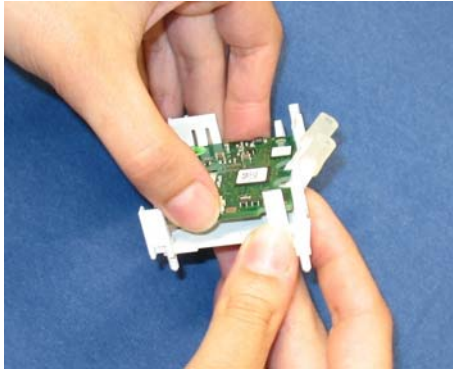

Reassembly Procedure

1. Stick the rubber airguide onto the airguide cage half as shown below.

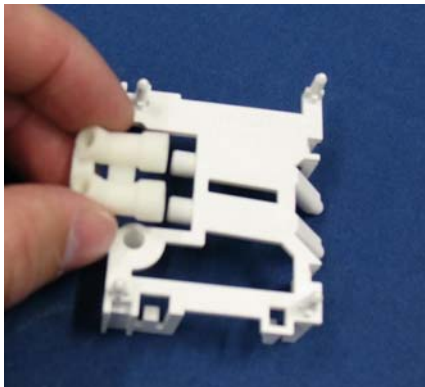

2. Place the airguide cage half with rubber airguide onto the plastic tubes on the measurement assembly. Make sure the rubber airguide is seated properly.

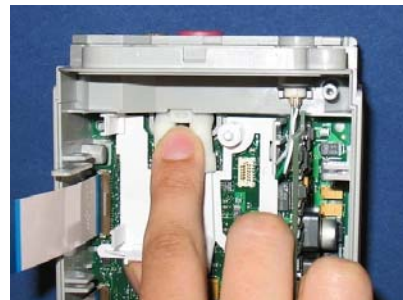

3. Make sure the posts of the airguide cage are inserted into the prepared holes on the main board.

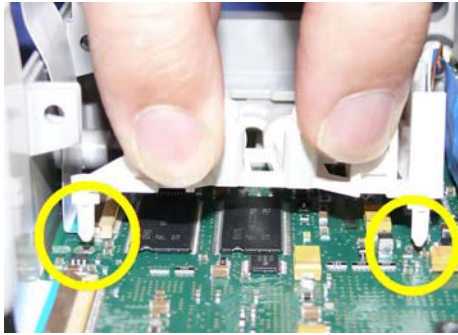

4. If an IIT or WLAN module is to be installed, insert the IIT system board or WLAN adapter board as shown below. The IIT system board or WLAN adapter board must be fitted under the white hooks.

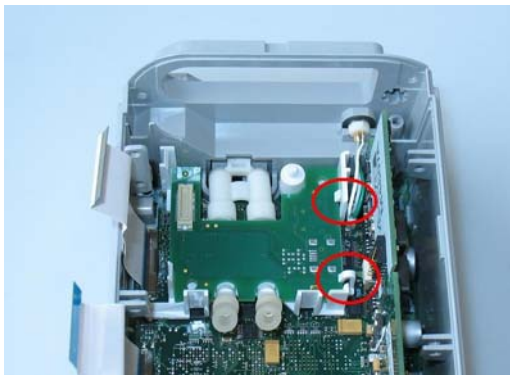
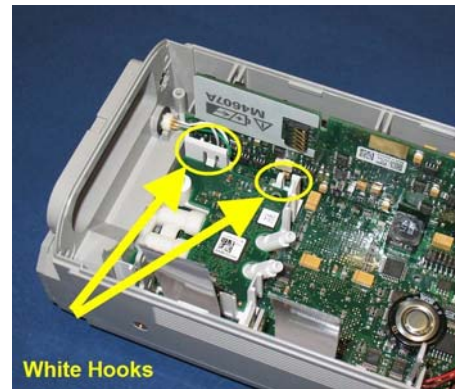
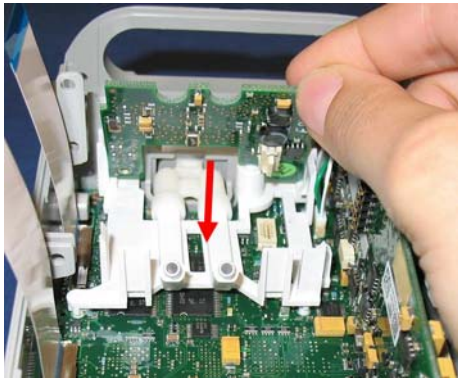

5. Plug the antenna cable into the IIT radio module or WLAN module.

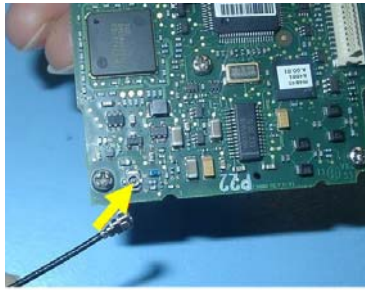

US Version



Non-US Version

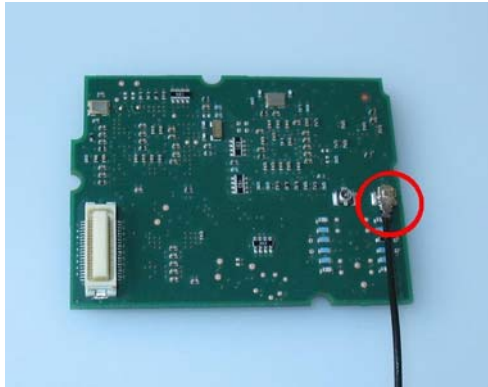

NOTE

Use only the right antenna connector.

6. Install the IIT radio module/WLAN module onto the IIT system board/WLAN adapter board. Make sure the antenna is placed into the prepared guiding rail.

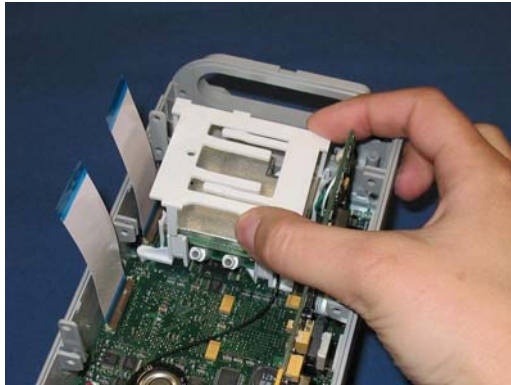

7. Insert the plastic airguide cover. For the WLAN installation, the airguide cover is grey. Be sure to use the appropriate airguide cover.

**NOTE**

Make sure the antenna cable is not covering the post connectors for the NBP flex.

8. Position the antenna as shown below. Make sure that the antenna is not covering any connectors.



9. Insert the silicon tubes and make sure they are seated correctly.



Exchanging the Loudspeaker

1. Remove the battery as described above.
2. Remove the handle as described above.
3. Remove the display as described above.

4. Remove the NBP pump assembly as described above.
5. Unplug the loudspeaker cable.

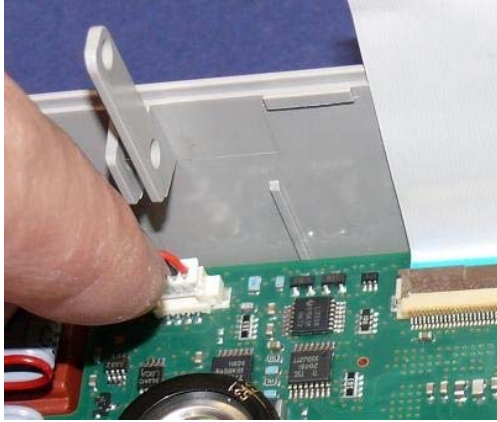

6. Lift up the speaker assembly with pliers. Position the pliers as shown below and pull the speaker assembly upwards. Note that there is no locking mechanism on the speaker assembly. Make sure you lift the speaker up straight



Reassembly Procedure

1. Position the new speaker as shown below and press the assembly down.

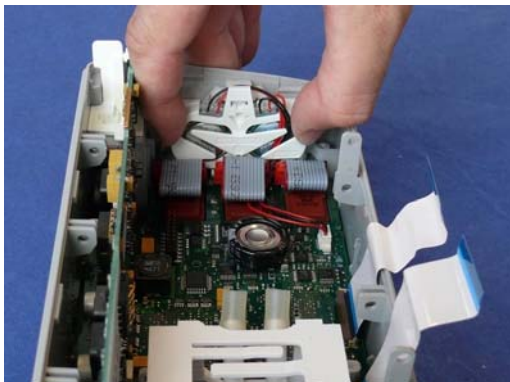

2. Plug in the speaker cable

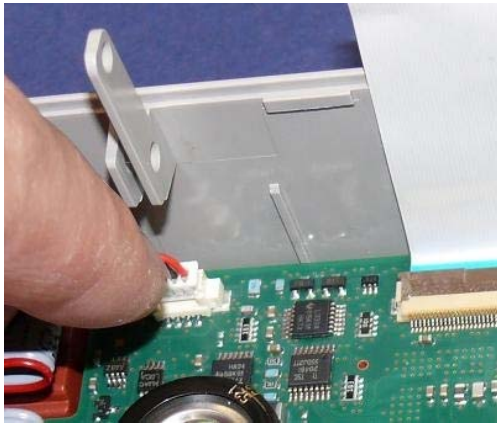

Removing the Power Board

NOTE

When replacing the power board, the monitor must have the serial number reloaded. A support tool is required to perform this task. Please see the Support Tool Instructions for Use document for details on how to load a new serial number.

1. Remove the battery as described above.
2. Remove the handle as described above.
3. Remove the display as described above.
4. Remove the NBP pump assembly as described above.
5. Remove the nameplate by moving it to the side. There will be a slight resistance when removing the nameplate. You may need to loosen the locking mechanism with a screwdriver before pulling off the nameplate.



- Carefully lift up the power board **only a few millimeters** in order to loosen the connection to the main board, then completely disconnect the power board from the main board by pressing gently on the black transformer. Make sure the ECG Sync Pulse Out connector and cable is not damaged.

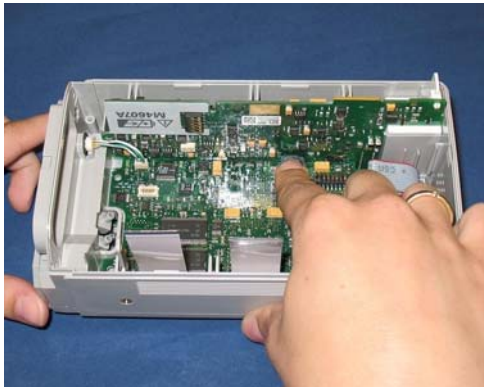
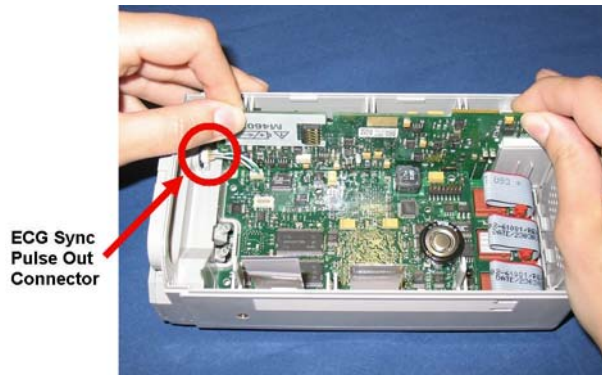

- Remove the power board by pushing up the MSL connector. Due to the sealing there will be a strong resistance when removing the board.



Reassembly Procedure

1. Insert the SRL cover into the prepared slots on the power board. The two grey dots on the plastic part must be next to the MSL connector.

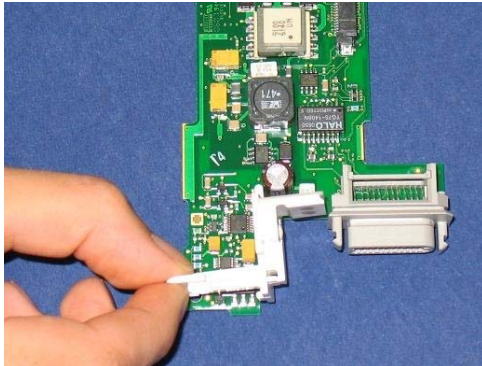

2. Make sure that after it is plugged into the power board, the cover is parallel to the power board and that the MSL connector and the cover form a line.

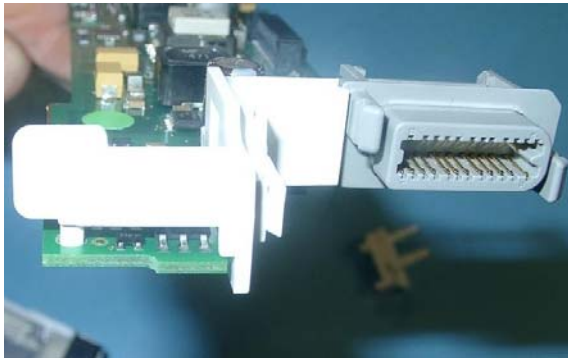

3. Insert the power board into the guiding rail on the housing and make sure the connection to the main board is established correctly.

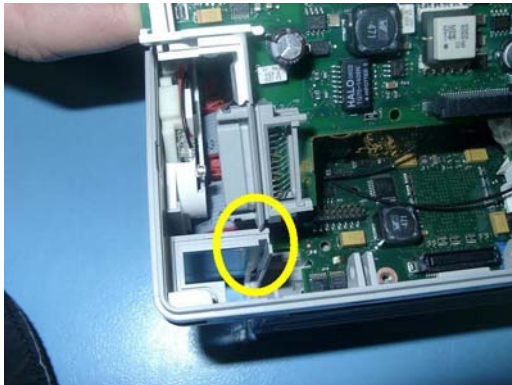

4. When the power board is connected to the main board, insert the name plate into the guiding of the power board.

**NOTE**

- Sometimes the name plate does not slide correctly into the dovetail locking mechanism. Make sure that the MSL power board is pressed down completely.
- Make sure the appropriate option is set with the support tool when reloading software. For further details, please refer to the support tool Instructions for Use.

Removing the ECG Sync Pulse Out Connector

1. Remove the battery as described above.
2. Remove the handle as described above.
3. Remove the display as described above.
4. Remove the NBP pump assembly as described above.
5. Remove the power board as described above.
6. Remove the NBP Airguide/Instrument Telemetry (IIT) Assembly
7. Unplug the ECG Pulse Out Connector.



- Position the screwdriver in between the spring and the connector and turn the screwdriver counterclockwise to remove the spring. Make sure the blade of the screwdriver fits into the hole of the spring. Hold on to the spring so it does not fall into the instrument.



- Pull out the complete ECG Sync Pulse Out cable and connector.

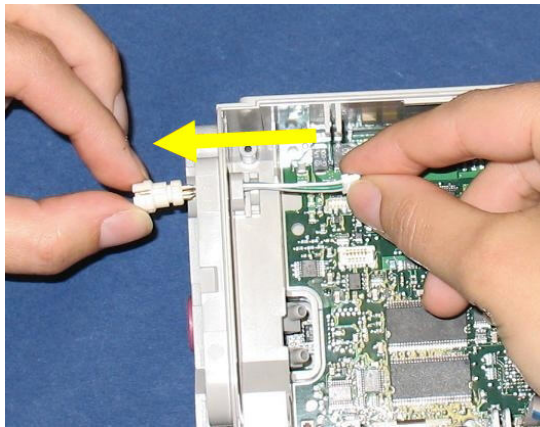

- For reassembly, push the connector from the outside to the inside of the main chassis. The connector is mechanically coded. Make sure that it is fitted correctly into its slot. Insert the spring and press it down.

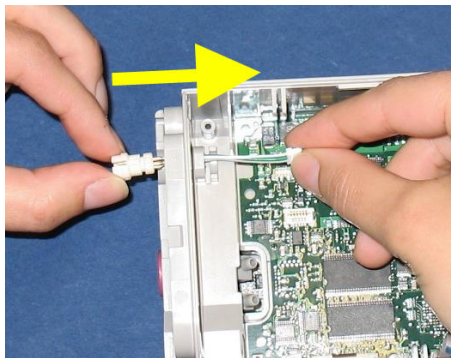

Removing the Main Board

When replacing the main board, the monitor must be reloaded with the software, purchased options and settings. A support tool is required to perform these tasks. Please see the Support Tool Instructions for Use document for details on how to load software, options and settings.

Before exchanging the main board, retrieve the status log from the monitor with the support tool. Please include a status log printout when returning the defective main board.

1. Remove the battery as described above.
2. Remove the handle as described above.
3. Remove the display as described above.
4. Remove the NBP pump assembly as described above.
5. Remove the power board as described above.
6. Remove the loudspeaker as described above.
7. Remove the NBP Airguide/Instrument Telemetry (IIT) Assembly as described above.
8. Remove the ECG Sync Pulse Out Connector as described above.
9. Unplug the connection to the measurements. Carefully loosen the connections by gently pulling the connectors and moving them back and forth. The connection between the measurements and the main board is very tight, therefore there will be some resistance when loosening them.



10. Remove the main board by lifting it up to the side on which the power board is connected.



NOTE

The housing has two plastic noses. Make sure the main board remains below these noses while it is being lifted. Otherwise the board will get stuck and cannot be lifted out.

11. Remove the flex cable by opening the plastic latch on the main board. Be very careful when opening the connector, because a broken latch cannot be replaced.

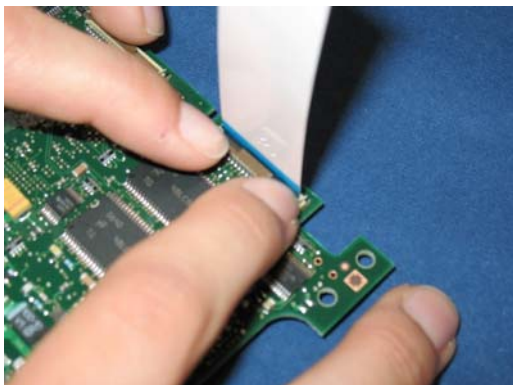

12. Reassemble by performing steps 1-10 in reverse order.

NOTE

When reinserting the main board, make sure it is placed below the plastic noses before pressing it in.

Removing the Rear Housing

NOTE

Depending on which repair or exchange needs to be performed, not all the components will need to be removed for removal of the rear housing. If only the rear housing needs to be exchanged, only the battery has to be removed.

1. Remove the battery as described above.
2. Remove the handle as described above.
3. Remove the display as described above.
4. Remove the NBP pump assembly as described above.
5. Remove the power board as described above.
6. Remove the ECG Out connector as described above.
7. Remove the Loudspeaker as described above.
8. Remove the IIT module as described above.
9. Remove the airways to the NBP pump as described above.

- Remove the pins holding the rear housing.



- Remove the rear housing. There might be a slight resistance due to the rubber sealing. Replace the rear housing.

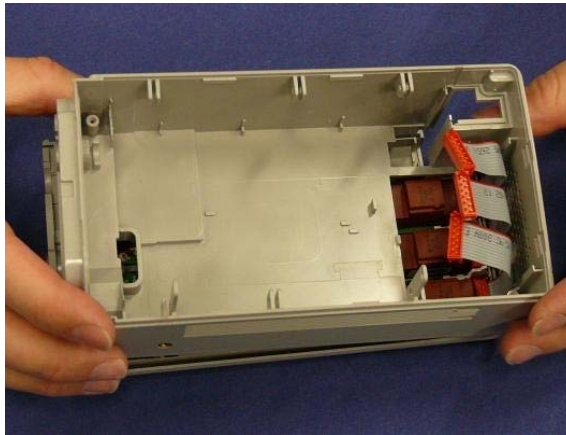

TIP

Due to the sealing, the housing may stick tight. In this case, a screwdriver can be used to loosen the bottom housing.

- Reassemble the monitor by performing the above steps in reverse order.
- Check the labeling on your old rear housing and apply the respective labels to your new rear housing.

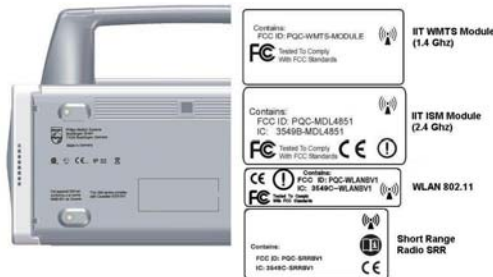

- Perform the leakage tests as described in the Testing and Maintenance section.

Removing the Measurements

1. Remove the battery as described above.
2. Remove the handle as described above.
3. Remove the display as described above.
4. Remove the NBP pump assembly as described above.
5. Remove the Loudspeaker as described above.
6. Remove the rear housing as described above.
7. Hold the main housing as shown below and press the measurements downwards. There will be a slight resistance due to the sealing.

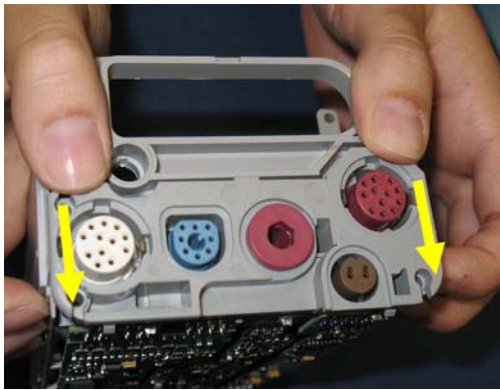

NOTE

The measurements can only be loosened if both sides are loosened simultaneously. If the measurements are only loosened on one side and get stuck, press the loosened side back down and try again.

8. When reassembling the measurements, make sure the cable is seated correctly. The plastic nose of the connector must be inserted as shown below.

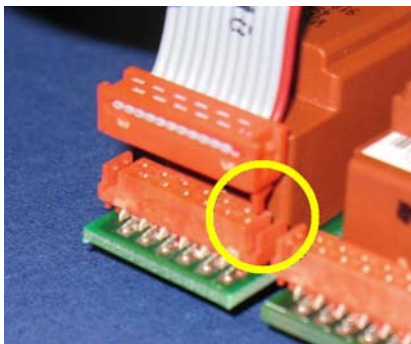

9. Insert the measurement spacer to guarantee correct seating. The measurements must be in one line.

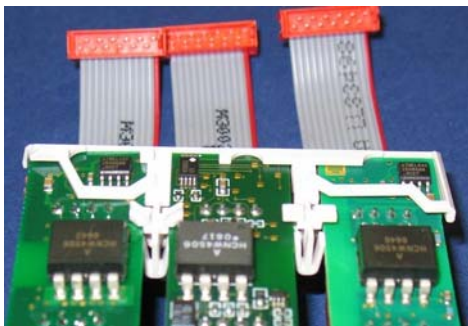

Exchanging the Main Housing

1. Remove the battery as described above.
2. Remove the handle as described above.
3. Remove the display as described above.
4. Remove the NBP pump assembly as described above.
5. Remove the power board as described above.
6. Remove the ECG Out connector as described above.
7. Remove the Loudspeaker as described above.
8. Remove the IIT module as described above.
9. Remove the airways to the NBP pump as described above.
10. Remove the rear housing as described above.
11. Remove the measurements as described above.
12. Insert the filter membrane into the new housing. Do not insert it into the ECG Sync Pulse Out connector slot.



13. Reassemble the monitor by performing steps 1 to 11 in reverse order

14. If you are not using a handle insert the screw cover.



15. Check the labeling on your old main housing and apply the respective labels to your new main housing.



16. Apply the speaker foil to cover the speaker holes in the housing.



Exchanging the Silicon Pads

1. Remove the battery as described above.
2. Remove the handle as described above.
3. Remove the display as described above.

4. Remove the battery release lever.



5. Remove the three screws securing the plastic HIF board holder (Torx 8).

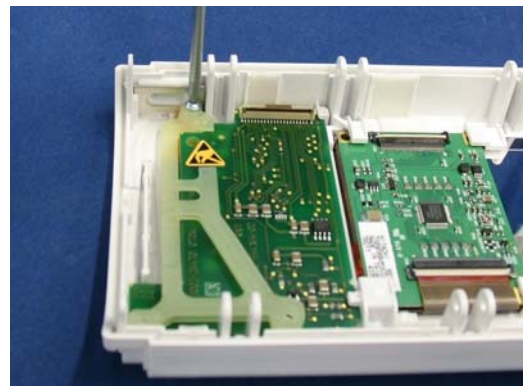
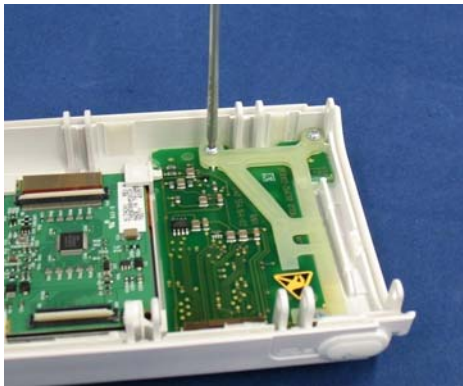

6. Remove the HIF board.



7. Remove the battery release lever guide.

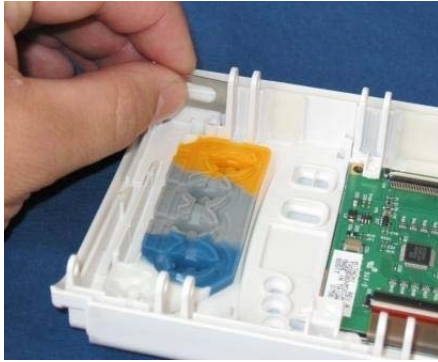

8. Remove the tappets.

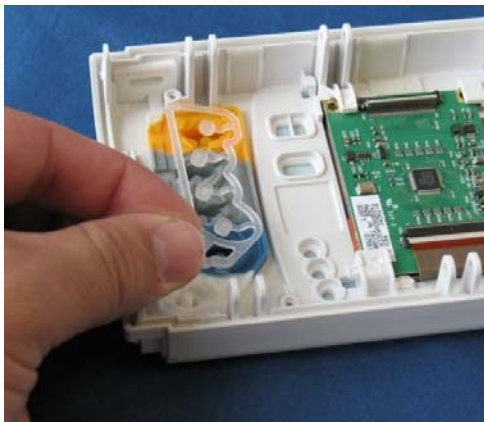

9. Remove the silicon pads.

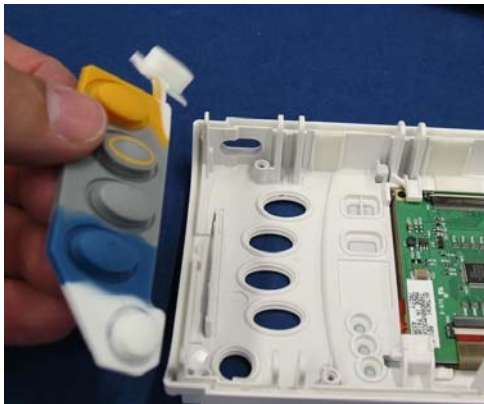

10. For reassembly, perform the above steps in reverse order.

Reassembly Note: Make sure the battery release lever is positioned correctly (see photo below).



MMS Extensions - Exchanging the Top Cover, MSL Flex Cable and the Dual Link Bar

This section describes the exchange procedures for:

- The Top Cover with new release mechanism
- The Dual Link Bar incl. the MSL Flex Cable.

for all MMS Extension (MSE) types (M3012A, M3014A, M3015A, M3016A).



Exchange Procedures

NOTE

Please follow the disassembly and reassembly steps closely.

Tools Required:

A thin-bladed screwdriver and a thick-bladed screwdriver, ESD mat and wrist strap

WARNING

- Do not open the MSE while it is connected to a monitor.
- Parts inside the instrument may be contaminated with bacteria. Protect yourself from possible infection by wearing examination gloves during this procedure.

NOTE

Once you have reassembled the MSE, you must perform a performance check on it. Please refer to the sections "Maintaining the Instrument" and "Testing the Instrument" .

Removing the Front Cover

1. Position the thin-bladed screwdriver in the small slot provided for this purpose. The front cover (Bezel) then clicks away from the Extension. Remove the front cover



NOTE

There might be a slight resistance when you remove the front cover.



Removing the Mounting Pin

1. Position the MSE on the dual link bar with the measurement connector hardware facing upwards and the arm of the dual link bar away from you. There are four long mounting pins threaded into the MSE in each of the four corners under the cover. Locate the heads of the two long mounting pins on the top housing and only remove these.
2. Use the thin-bladed screwdriver to lift the pins gently out far enough so they can be removed manually.



3. Remove the two pins and set them aside for refitting.

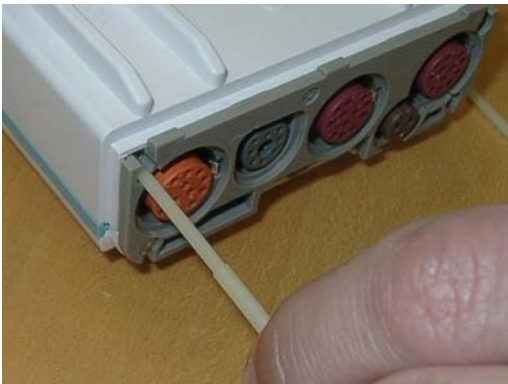

NOTE

Without these long mounting pins the MSE will not function properly.

Removing the Dual Link Bar

The Dual Link Bar consists of three parts as shown below. Follow the specific steps carefully to remove the Link Bar.

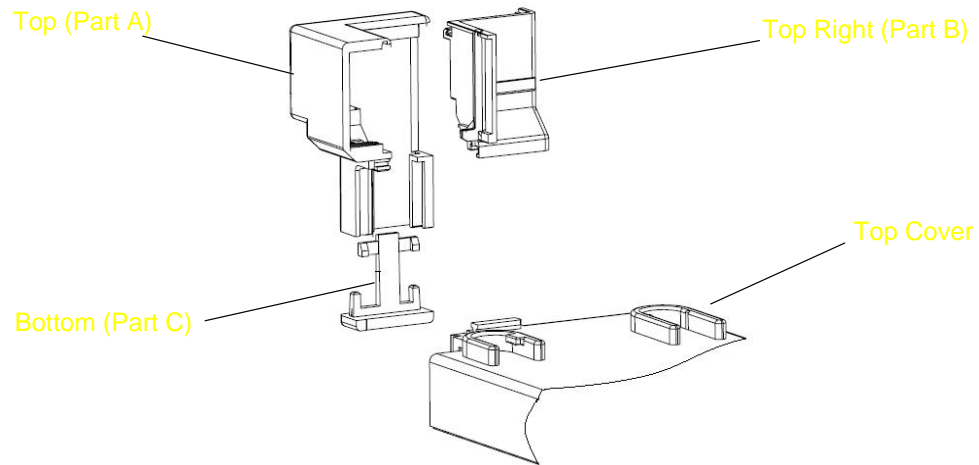

CAUTION

Do not try to remove the link bar with force as this can damage the MSL Flex Cable

1. Position the MSE with the measurement connector hardware facing towards you.
2. Hold the link bar as shown below. While pressing gently on part B, insert a thick-bladed screwdriver between the MSL connector and part A. Twist the screwdriver to the left and at the same time slide part B to the right, so it is released at the top.



3. Repeat Step 2 at the bottom.



4. Slide part B to the right. If part B fails to move to the side, please repeat steps 2 and 3.



5. Now the MSL Flex connector can be moved to the right.

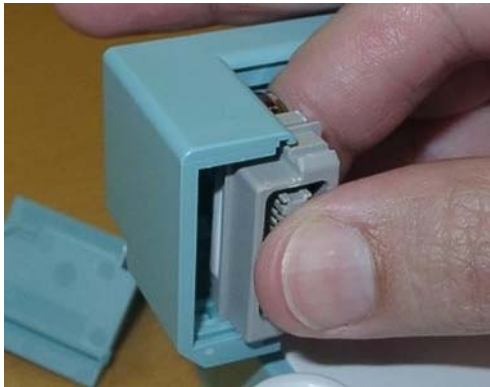

NOTE

Make sure that the movement of the screwdriver does not pinch the MSL flex cable.

6. Insert the thin-blade screwdriver behind the release mechanism of part C. Carefully twist the screwdriver, then press gently so that part C drops down.

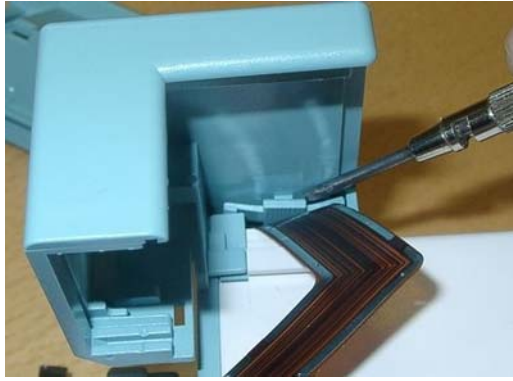

7. Lift part A upwards. It is fixed in a dovetail. Be careful with the MSL flex.



Removing the Top Cover

Begin by gently pulling away the top cover from the MSE. The top cover is press-latched at the link bar end. Remove it slowly, without hitting or touching the inside of the MSE.



Replacing the Flex Cable Assembly

1. Hold the Extension firmly and push upwards against the connector. Then slide connector (together with the connector holder) out of the dovetail connection.

NOTE

You will probably need to apply some more force at first until the holder slides out of its mechanical lock.

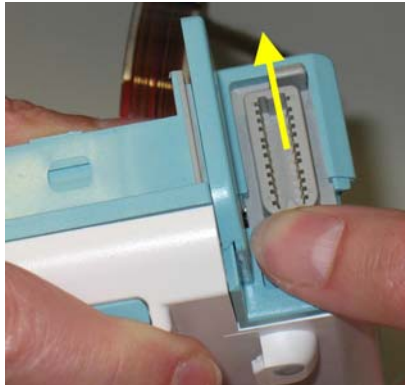

2. Slide the connector out of its holder.

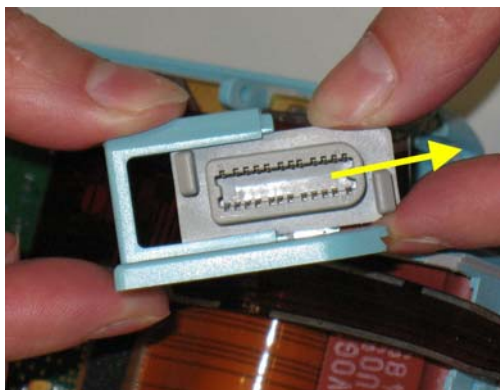

3. Remove the flex cable connector on the MSE board. Be careful not to bend any pins on the female part of the MSE connector.

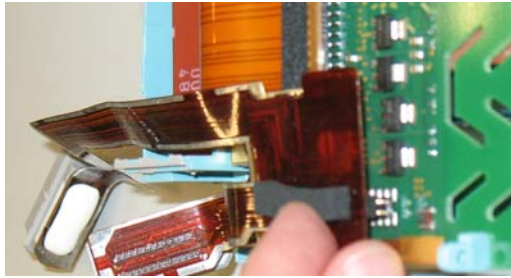

NOTE

Some units may have a foam pad on the connector of the inner flex cable of the MSEs (as shown below) and some units may not. This has no impact on the functionality of these units.

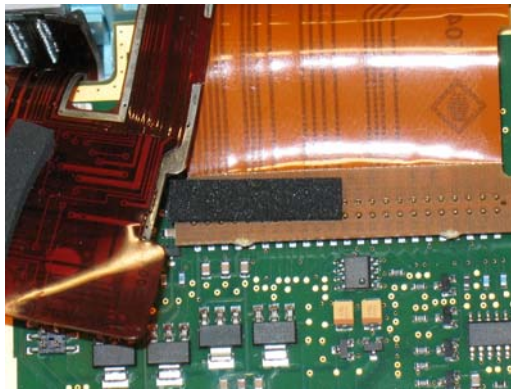

4. Stick the correct foam pad on the rear side of the inner connector. Use the thick pad for : M3012A, M3014A, M3016A. Use the thin pad for: M3015A. You can also check the old flex cable for the correct pad.

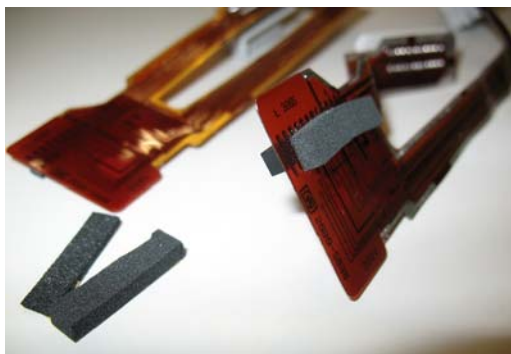

5. Insert the flex cable connector into the female receptacle on the MSE board. **Check from the side and the front that the connector is inserted correctly (there is no mechanical guidance) and that no pins are bent, otherwise you may damage the MSE when powering it on.**

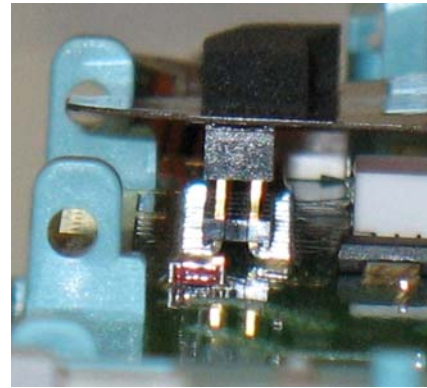
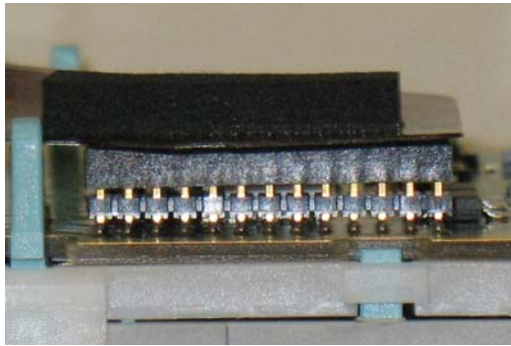

WARNING

A misplaced connector might damage the MSE or the monitor.

6. Slide the connector into the holder as shown below. Arrange the flex cable in the space beside and underneath the board (be careful not to bend the cable) while positioning the holder for insertion.

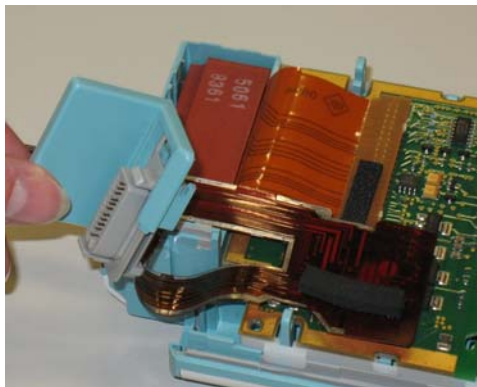

7. Insert the holder with the connector into the dovetail connection and slide it down until you hear a click.



Refitting the Top Cover

NOTE

Be careful with the MSL Flex cable. Make sure it does not get stuck between the covers.

1. Position top cover, then press the bottom cover back into place until a click is heard.
2. The cover has a rubber seal. Press the covers firmly together and make sure there is no gap between the top and bottom cover.

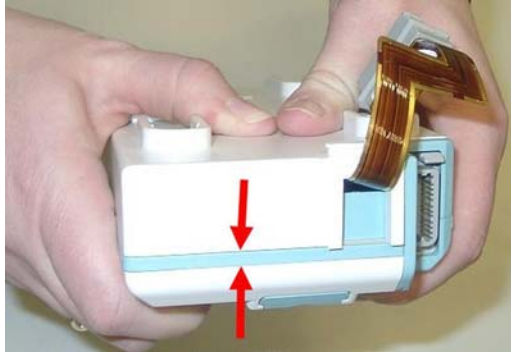

3. Holding the bottom cover firmly in place, slide the two long mounting pins completely back into the MSE.

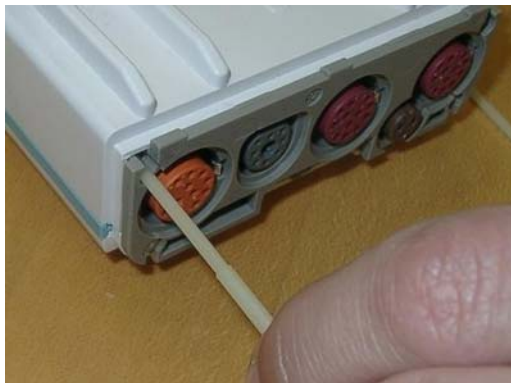

Assembling the dual Link Bar

CAUTION

Do not try to assemble any part of the link bar with force as this can damage the MSL Flex Cable.

1. Position part A into the dovetail and slide it down.



2. Make sure the MSL Flex connector is positioned in the correct slot (See indicated slots below). Then push it gently into part A.

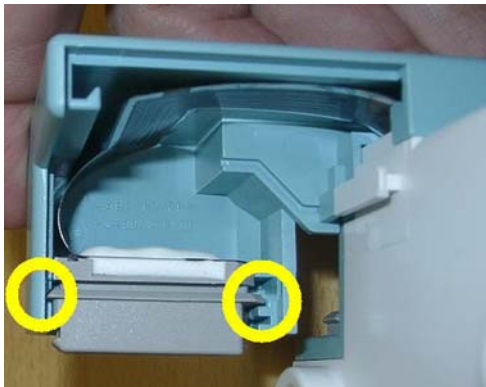

3. Making sure the MSL flex cable lies flat in part A of the assembly, place part B into the dovetail and close the open link bar.



4. Turn the MSE around and insert part C into the bottom part of the link bar. When you hear a click, part C is correctly inserted.



Refitting the Front Cover

To refit the front cover, press it back into place over the measurement connector hardware until you hear a click.



Final Inspection

Perform a final inspection to ensure that:

- The link bar is positioned correctly
- There are no gaps between the link bar parts
- There is no gap between the top and bottom cover



Testing

To ensure that the MSE is functioning correctly, you must perform a performance check on it. Please refer to the sections "Maintaining the Instrument" and "Testing the Instrument".

Disassembly Procedures for the M3015A MMS Extension (HW Rev. A)

NOTE

These procedures apply only to M3015A MMS with Serial Numbers DE020xxxxx.

It is recommended that you replace all the replaceable parts in the Extension (CO2 Scrubber and Pump) after 15 000 hours (approximately 3 years) of continuous use.

Tools Required:

- A thin-bladed screwdriver.
- A pair of large tweezers.
- In addition, for removing the pump, you will need a large-bladed screwdriver.

WARNING

There is high voltage inside the Instrument (800V). Do not connect the MMS Extension to a Monitor while the Extension housing is open.

As well, parts inside the Instrument may be contaminated with bacteria. Protect yourself from possible infection by wearing examination gloves during these procedures.

Removing the Front Cover

To remove the front cover, do the following:

1. Remove the server and the monitor from the extension.
2. Use a thin-bladed screwdriver to prise the grey front cover (the console covering the measurement connector hardware) gently from the bottom of the extension. Position the screwdriver in the small slits provided for this purpose. The front cover then clicks away from the extension.

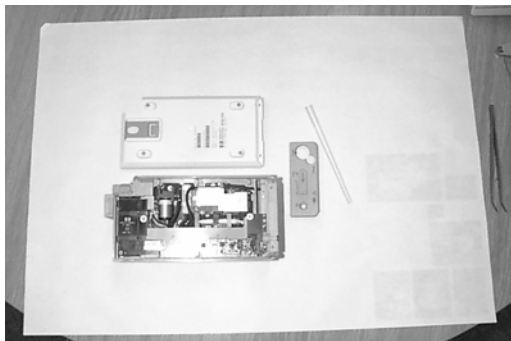

3. Remove the front cover.

Removing the Extension Bottom Cover

To remove the Extension bottom cover, do the following:

1. Position the extension on the dual link bar with the measurement connector hardware facing upwards and the arm of the dual link bar towards you. There are four long mounting pins threaded into the extension in each of the four corners under the cover. Locate the heads of the two long mounting pins on the side away from you
2. Use tweezers to prise the pins gently out enough to be removed by hand.
3. Remove the two pins and set them aside for refitting.

NOTE

Do not lose these long mounting pins since the Extension will not function unless they are in place.



4. Using your hands, gently pry the bottom cover away from the Extension at the link bar end first. The bottom cover is press-latched at the link bar end. Remove it gently making sure not to bang or touch the inside of the Extension.

NOTE

If you accidentally try to remove the wrong side of the bottom cover, you will notice that it is attached to the inside of the Extension with a ribbon connector and that the dual link bar prevents you from removing it completely. **Do not try to forcibly remove the wrong side of the M3015A cover; you cannot access replaceable parts from this side.**

The following illustration shows the location of the replaceable parts in the M3015A Measurement Server Extension.

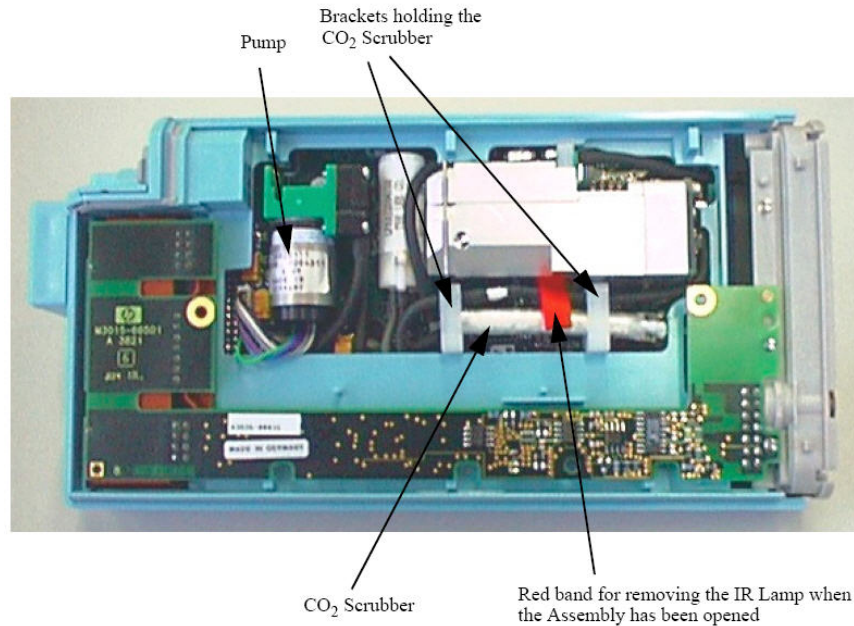
**Removing the CO₂ Scrubber**

To remove the CO₂ Scrubber, do the following:

1. Locate the CO₂ Scrubber in the Extension.
2. Being careful not to touch anything else in the Extension, use tweezers to pull the body of the CO₂ Scrubber out of the bracket.

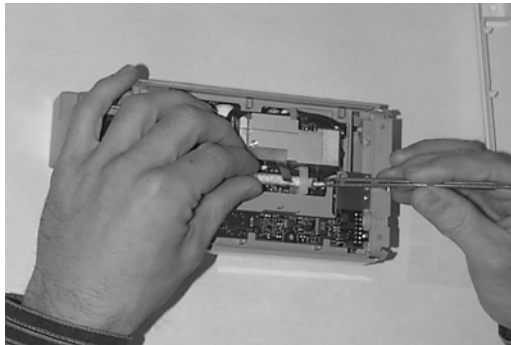

3. Holding the body of the CO₂ Scrubber with your fingers, carefully disconnect the Extension intake tube from the scrubber end and remove the CO₂ Scrubber from the Extension.

4. Dispose of the CO₂ Scrubber according to local legal requirements for low volume chemical waste.

NOTE

Now that it is exposed, do **NOT** allow anything to fall into the Infrared Lamp assembly.

Removing the Pump

To remove the Pump, do the following:

1. Locate the Pump in the Extension.
2. Being careful not to touch anything else in the Extension, unscrew the screw holding the pump bracket in position. Lift the top part of the bracket away and lift out the pump.

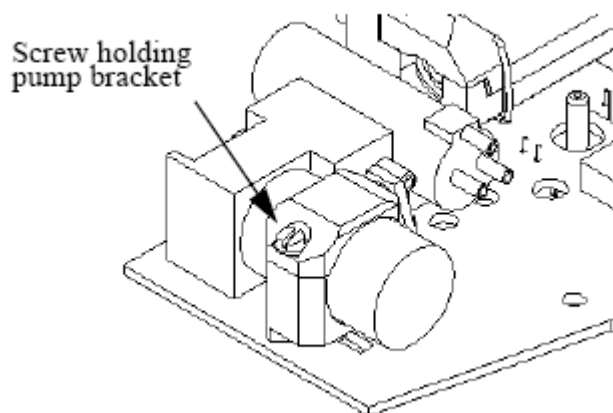

3. Gently disconnect the flow tubing attached to the Extension from the Pump.

NOTE

Be sure to note which tube attaches to the inlet and which tube attaches to the outlet.

4. Gently disconnect the power lead which attaches the Pump to the Extension.

5. Remove the Pump.

NOTE

After replacing the Pump, reset the displayed value displayed using the Reset PumpOpTime selection (Service Mode>CO₂ Setup). When the PumpOpTime has been reset an INOP will be generated: "CO₂ OCCLUSION". To clear this INOP you must perform a flow check and store the flow in Service Mode (select "Store Flow")

Refit Procedures for the MMS Extension

Tools Required:

- A thin-bladed screwdriver.
- A pair of large tweezers.
- In addition, for refitting the Pump, you will need a large-bladed screwdriver.

WARNING

There is high voltage inside the Instrument (800V). Do not connect the MMS Extension to a Monitor while the Extension housing is open.

As well, parts inside the instrument may be contaminated with bacteria. protect yourself from possible infection by wearing examination gloves during these procedures.

Refitting the CO2 Scrubber

WARNING

The CO2 Scrubber contains lithium hydroxide monohydrate. This is a strong base. Do not open or damage the CO2 Scrubber. If you come into contact with the CO2 Scrubber material, flush the area immediately with water and consult a doctor.

To refit the CO2 Scrubber, do the following:

1. O2 Scrubber through the bracket to meet the Extension intake tube.
2. Push the intake tube firmly into the scrubber end to connect it.
3. Holding the body of the CO2 Scrubber with tweezers, feed the CO2 Scrubber fresh air intake under the second bracket and position it.

Refitting the Pump

To refit the Pump, do the following:

1. Gently connect the power lead to the Extension.

NOTE

The power lead can only be connected one way. Do not try to force the power lead into position. Instead, align it correctly and connect it gently.

2. Connect the flow tubing to the Pump.

NOTE

Be sure to reconnect the inlet tube to the inlet valve and the outlet tube to the outlet valve.

3. Being careful not to touch anything else in the Extension, insert the pump into the bracket on the PC board. Make sure that the pump is horizontal and does not touch the PC board. (Vibration from the pump in operation will damage the Extension if the pump touches the PC board.)
4. Replace the top part of the bracket and screw firmly into position.

NOTE

After replacing the Pump, reset the displayed value using the Reset PumpOpTime selection (Service Mode>CO2 Setup). When the PumpOpTime has been reset an INOP will be generated: “CO₂ OCCLUSION”. To clear this INOP you must perform a flow check and store the flow in Service Mode (select “Store Flow”).

Refitting the Extension Bottom Cover

To refit the Extension bottom cover, do the following:

1. Latch the link bar end into place then press-click the bottom cover back into place covering the interior of the Extension.
2. Holding the bottom cover firmly in place, thread the two long mounting pins back into the Extension making sure to thread them all the way to the end.

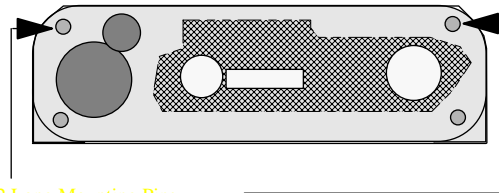
**Refitting the Front Cover**

To refit the front cover, press-click it back into place over the measurement connector hardware.

General Reassembly/Refitting Comments

- Ribbon Connections—Make sure male-female ribbon connections are correctly lined-up.
- Open Component—Do not allow anything to fall into the open component.

Following Reassembly

Once you have reassembled the Instrument, you must perform a safety and performance check on the Instrument. Refer to *Testing and Maintenance*.

Smart Battery Charger LG1480 (M8043A)

You should clean both air filter mats on a regular basis. Depending on the frequency of use and the environmental conditions (dust etc.), the interval can range from 6 to 24 months.

Cleaning the Air Filter Mats

The air filters are located on the right and left side of the battery conditioner. Perform the procedure below for each side.

1. Remove the 2 screws securing the filter cover and take off the cover.

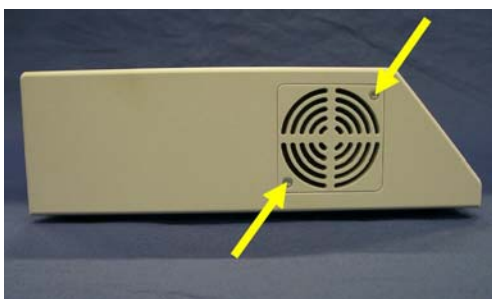

2. Remove the filter mat and clean the dust out by shaking.



3. Re-insert the mat and refit the cover and screws.

Replacing the Fan

1. Turn the battery conditioner upside down and remove the 5 screws at the bottom with a T20 screwdriver.

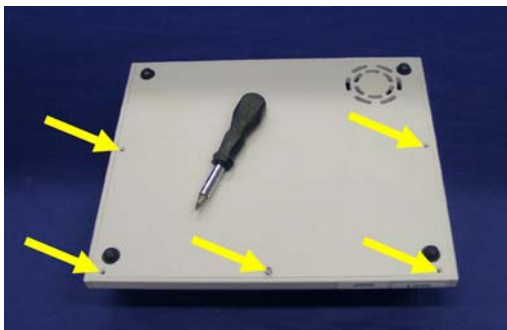

2. Lift the bottom cover up at the front and pull it off.



3. Unplug the fan connector from the main board.



4. Lift the fan out of the battery conditioner housing.



5. When replacing the fan make sure the connector is plugged in correctly as shown in the photograph below.

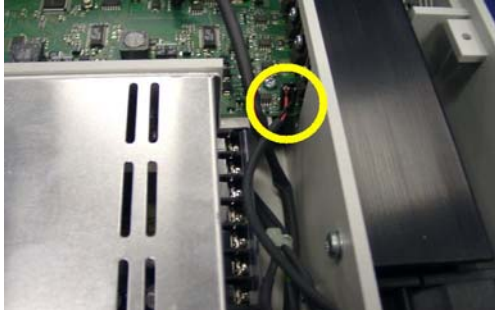

Parts

NOTE

- For part numbers of interconnecting cables, please consult the *Site Preparation* and *Installation Instructions* sections. For network-related parts, please see the M3185A Philips Clinical Network documentation.

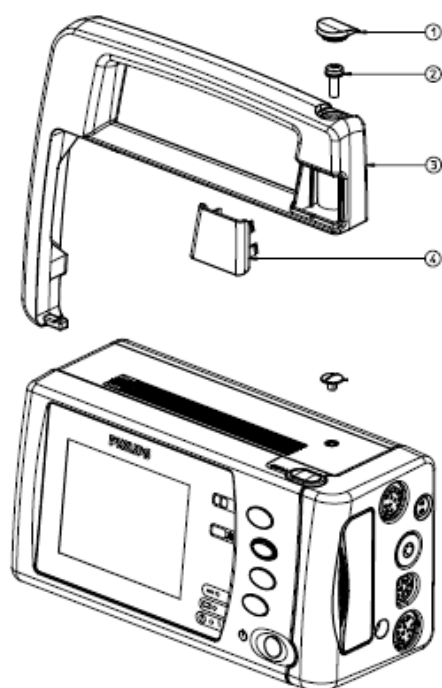

X2/MP2 Handle Kit

No. in Diagram	Exchange Part Number 12NC Part #/CMS Part #	New Part Number 12NC Part #/CMS Part #	Description
1,2,3,4		451261021051 M3002-64100	X2/MP2 Handle Kit (MP2 & X2) branding covers included)

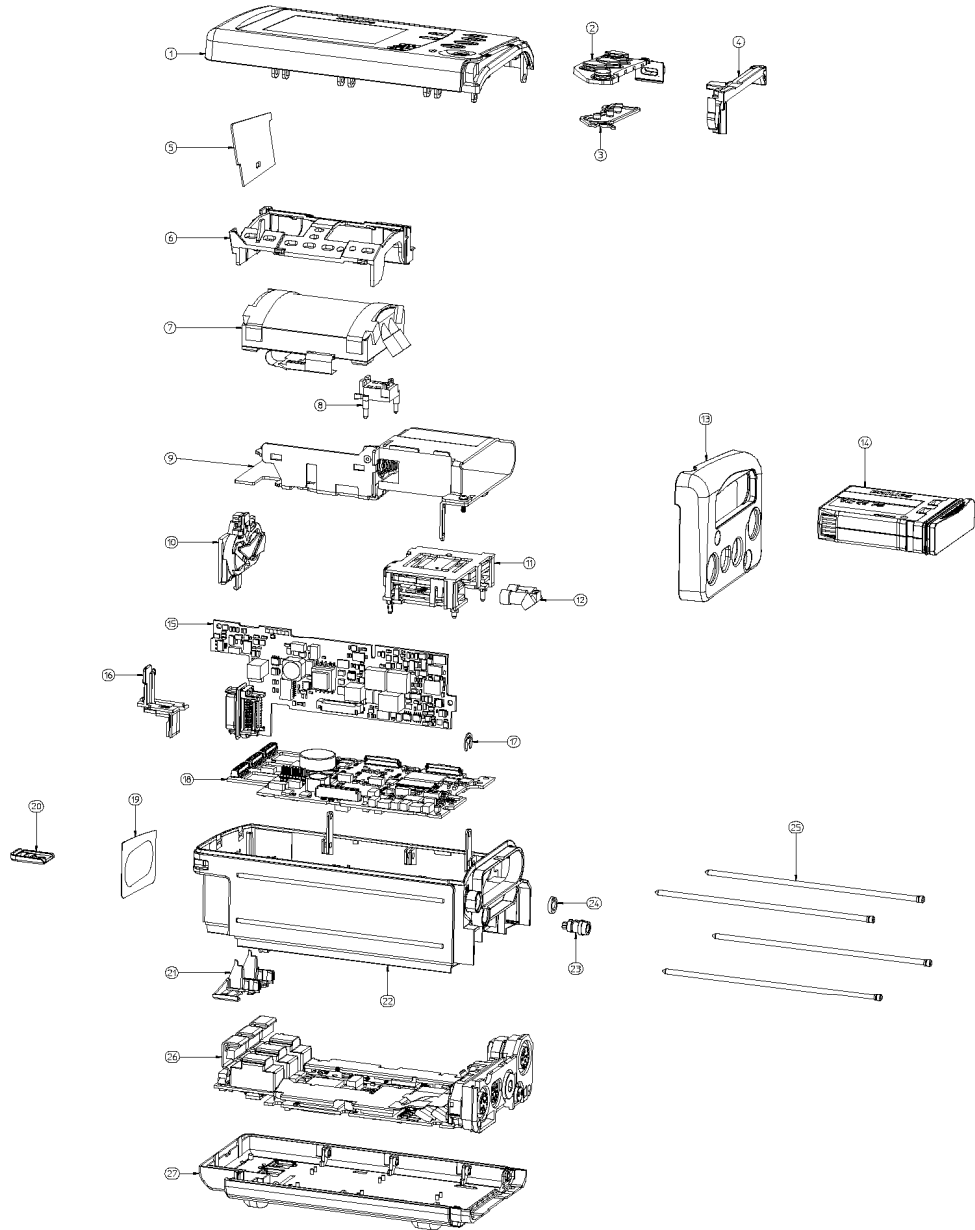

X2/MP2 Exchange Parts

Exchange and Replacement Parts

No. in Diagram	Part Number 12NC Part #/CMS Part #	Description
18	451261020901 M3002-68550	X2/MP2 Main board
15	451261020921 M3002-68580	X2/MP2 MSL Power board
26	451261020751 M3001-68557	ECG-5ld/Fast SpO2 PCA
26	451261020771 M3001-68553	ECG-5ld/Masimo SET SpO2 PCA
26	451261020811 M3001-68559	ECG-12ld/Fast SpO2 PCA
26	451261020831 M3001-68554	ECG-12ld/Masimo SET SpO2 PCA
26	451261020871 M3002-68560	ECG-5ld/Fast SpO2/P&T PCA
26	451261023451 M3002-68549	ECG-5ld/MasimoSpO2/P&T PCA
26	451261023491 M3002-68561	ECG-12ld/Fast SpO2/P&T PCA
26	451261023511 M3002-69550	ECG-12ld/Masimo SpO2/P&T PCA
26	451261023551 M3002-68562	ECG-5ld/Fast SpO2/CO2 PCA
26	451261023571 M3002-68551	ECG-5ld/Masimo SpO2/CO2 PCA
26	451261023611 M3002-68563	ECG-12ld/Fast SpO2/CO2 PCA
26	451261023631 M3002-68552	ECG-12ld/Masimo SpO2/CO2 PCA
10	451261020931 M3002-60017	X2/MP2 Speaker Assembly
7	451261020561 M3001-64500	NBP Pump Assembly
14	989803148701 M4607A	X2/MP2 Battery 10.8V 1Ah LiIon

No. in Diagram	Part Number 12NC Part #/CMS Part #	Description
n/a	451261017451 M4607-60001	X2/MP2 Battery Charger Adapter
n/a	451261023711 M8023-60000	X2/MP2 External Power Supply
1*	451261020961 M3002-67010	MP2 Front Display Symbol
1*	451261020971 M3002-67011	X2 Front Display Symbol
1	453564113811	X2 Front Display Symbol w. SRR
1	453564113841	MP2 Front Display Symbol w. SRR
1*	451261020981 M3002-67021	MP2 Front Display English Text
1*	451261020991 M3002-67021	X2 Front Display English Text
1	453564113831	MP2 Front Display English Text w. SRR
1	453564113821	X2 Front Display English Text w. SRR
n/a	451261020541 M3002-44701	X2/MP2 Anti-slip Pad (5x)
13	451261021011 M3002-64210	X2/MP2 Side Bezel Set Text (English) (includes all options)
13	451261021021 M3002-64211	X2/MP2 Side Bezel Set Symbol (includes all options)
16, 18, 22, 24, 25	451261021031 M3002-64050	MP2/X2 Main Housing Assembly
27	451261021041 M3002-64060	MP2/X2 Rear Housing Assembly
6,8,11,12	451261021061 M3002-64070	X2/MP2 NBP Airway Kit
n/a	451261021071 M3002-64080	X2/MP2 Cable Kit
2, 3, 4	451261021081 M3002-64090	X2/MP2 Display Kit
11	451261021091 M3002-60525	X2/MP2 IIT Assembly ROW 2.4 GHz
11	451261021101 M3002-60515	X2/MP2 IIT Assembly US 1.4 GHz

No. in Diagram	Part Number 12NC Part #/CMS Part #	Description
n/a	989803153021	X2/MP2/MP5 Rollstand
n/a	453564113271	X2 Wireless Assembly 802.11 (incl. cage)
n/a	451261021191 M3002-61601	X2 Cable ECG Out

* Parts 2,3, and 4 are included in the kit.

**X2/MP2 Main Housing Assembly Kit Contents-
M3002-64050 (451261021031):**

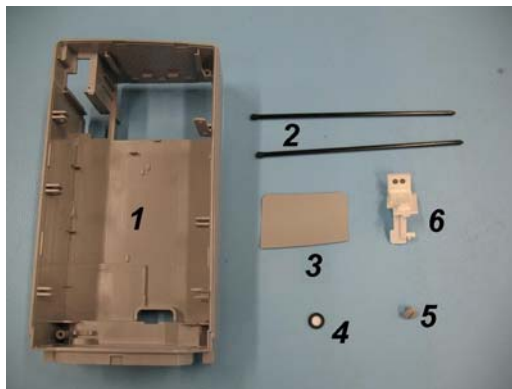

Description	No. in picture
Main Chassis assembly	1
O-Ring Membrane Filter	4
Label Sheet	n/a
Pin X2/MP2	2
Overlay Speaker	3
SRL holder Assembly	6
Chassis screw hole cover	5

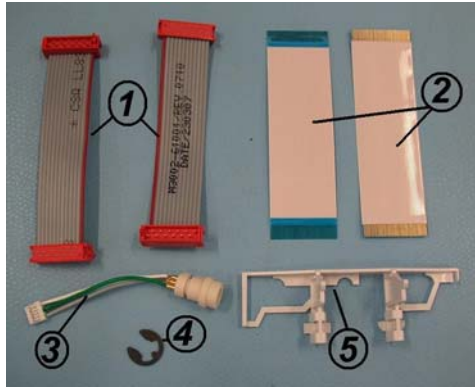
X2/MP2Cable Kit Contents-M3002-64080 (451261021071):

Description	No. in picture
Connector ECG Out	3
Spring	4
Flat flex cable	2
Spacer	5
Front-End cable	1

MMS Extension Parts (M3012A, M3014A, M3015A and M3016A)

Exchange MMS Extensions are shipped with English front bezels only. If you require a bezel in another language (compare the part numbers of your language to the English ones to check this) the front bezel has to be ordered additionally. Attach the appropriate bezel before putting the MMS extension into operation.

The part numbers in the following parts table below, are used to order parts from your Philips representative. The item numbers correspond to the illustration which follows.

MMS Extension Part Numbers - Release Mechanisms

Part Number	12NC Part Number	Description
M3014-64200	451261012731	MMS Extension clips and springs (10 each) for MMS extension release mechanism (old version)

Part Number	12NC Part Number	Description
M3001-64600	451261012721	MMS Extension lever locks.(packet of 5) for MMS extension release mechanism (new version)



MMS Extension Part Numbers - Top Cover, Flex Cable and Link Bar

Part Number	12NC Part Number	Description
M3012-64620	451261016601	MSE Top Cover Assembly
M3012-64621	451261016611	MSE Link Bar Assembly
n/a	453564088851	MSE Flex Cable Connector Assembly

MMS Extension Part Numbers - Front Bezels

12NC Part No.	Description
M3012A #C00 - Pressure, Temp & Press/Temp	
451261024471	M3012A Front Bezel P, T, P/T Eng. Text
451261024481	M3012A Front Bezel P, T, P/T Symbols
M3012A #C05 - Cardiac Output, Pressure, Temp & Press/Temp	
451261024491	M3012A Front Bezel C.O.,P, T, P/T Eng. Text
451261024501	M3012A Front Bezel C.O.,P, T, P/T Symbols

12NC Part No.	Description
M3012A #C10 - Cardiac Output, Continuous Cardiac Output, Pressure, Temp & Press/Temp	
451261024511	M3012A Front Bezel CCO, C.O.,P, T, P/T Eng. Text
451261024521	M3012A Front Bezel CCO, C.O.,P, T, P/T Symbols
M3014A #A01 - Capnography Extension	
451261024531	M3014A Front Bezel CO2 only Eng. Text/Symbols
M3014A #C05 - Cardiac Output, Mainstream CO2, Pressure & Press/Temp	
451261024541	M3014A Front Bezel C.O., CO2, P, P/T Eng. Text
451261024551	M3014A Front Bezel C.O., CO2, P, P/T Symbols
M3014A #C07 - Mainstream CO2, Pressure & Press/Temp	
451261024561	M3014A Front Bezel CO2, P, P/T Eng. Text
451261024571	M3014A Front Bezel CO2, P, P/T Symbols
M3014A #C10 - Cardiac Output, Continuous Cardiac Output, Mainstream CO2, Pressure & Press/Temp	
451261024581	M3014A Front Bezel C.O., CCO, CO2, P, P/T Text
451261024591	M3014A Front Bezel C.O.,CCO, CO2, P, P/T Symb.
M3015A #C06 Sidestream CO2 with Press/Temp	
451261024601	M3015A Front Bezel CO2 w P/T Eng. Text
451261024611	M3015A Front Bezel CO2 w P/T Symbols
M3015A Sidestream CO2 without Press/Temp	
451261024621	M3015A Front Bezel CO2 w/o P/T Eng. Text
451261024631	M3015A Front Bezel CO2 w/o P/T Symbols
M3015A Pump Kit And Mounting Pin (only for HW Rev. A)	
453563332261 (M3015-29303)	M3015A Pump Kit (including CO2 scrubber)
453563100081 (5041-8114)	Mounting Pin for M3015A

12NC Part No.	Description
M3016A (Press/Temp with Mainstream CO2)	
451261024641	M3016A Front Bezel CO2, P/T Eng. Text
451261024651	M3016A Front Bezel CO2, P/T Symbols

Exchange Parts List

Exchange parts are parts that have been returned to Philips and reconditioned for further use. Parts offered as exchange parts are in excellent service order according to rigorous Philips standards but offer you a considerable price advantage.

Part Number	12NC Part No.	Description	Item
M3012-6801A	451261000201	exchange M3012A MMS Extension with Pressure, Temperature, Press/Temp, For all languages apart from Danish, French, Italian, Chinese and Japanese, order also the local language bezel as shown in the previous "List of Parts"	Not shown
M3012-6831A	451261000341	exchange M3012A MMS Extension with Cardiac Output, Pressure, Temperature, Press/Temp, For all languages apart from Danish, Italian, Chinese and Japanese, order also the local language bezel as shown in the previous "List of Parts"	Not shown
M3012-6861A	451261000491	exchange M3012A MMS Extension with Continuous Cardiac Output, Pressure, Temperature, Press/Temp, For all languages apart from Danish, Italian, Chinese and Japanese, order also the local language bezel as shown in the previous "List of Parts"	Not shown
M3014-6801A	451261009281	exchange M3014A MMS Extension with CO2 For all languages apart from Danish, Italian, Chinese and Japanese, order also the local language bezel as shown in the previous "List of Parts"	Not shown

Part Number	12NC Part No.	Description	Item
M3014-6831A	451261009311	exchange M3014A MMS Extension with CO2, Cardiac Output, Pressure, Press/Temp For all languages apart from Danish, Italian, Chinese and Japanese, order also the local language bezel as shown in the previous "List of Parts"	Not shown
M3014-6891A	451261009461	exchange M3014A MMS Extension with CO2, Pressure, Press/Temp For all languages apart from Danish, Italian, Chinese and Japanese, order also the local language bezel as shown in the previous "List of Parts"	Not shown
M3014-6861A	451261009601	exchange M3014A MMS Extension with CO2, Cardiac Output/Continuous Cardiac Output, Pressure, Press/Temp For all languages apart from Danish, Italian, Chinese and Japanese, order also the local language bezel as shown in the previous "List of Parts"	Not shown
M3015-6801A	453563332431	exchange M3015A MMS Extension with Pressure/Temperature, English. (old hardware, S/N prefix: DE020xxxxx)* For all languages apart from French, Danish and Chinese, order also the local language bezel as shown in the previous "List of Parts".	Not Shown
M3015-6802A	451261005311	exchange M3015A MMS Extension with Pressure/Temperature, English. (new hardware, S/N prefix: DE435xxxxx)* For all languages apart from French, Danish and Chinese, order also the local language bezel as shown in the previous "List of Parts".	Not shown
M3015-6831A	453563477871	exchange M3015A MMS Extension without Pressure/Temperature, English. (old hardware, S/N prefix: DE020xxxxx)* For all languages apart from French, Danish and Chinese, order also the local language bezel as shown in the previous "List of Parts"	Not Shown

Part Number	12NC Part No.	Description	Item
M3015-6832A	451261005331	exchange M3015A MMS Extension without Pressure/Temperature, English. (new hardware, S/N prefix: DE435xxxxx)* For all languages apart from French, Danish and Chinese, order also the local language bezel as shown in the previous "List of Parts"	
M3016-6801A	453563332581	exchange M3016A MMS Extension with CO2, English. #A01 For all languages apart from French, Danish and Chinese, order also the local language bezel as shown in the previous "List of Parts".	Not Shown
M3016-6831A	453563483901	exchange M3016A MMS Extension without CO2, English. #A02 For all languages apart from French, Danish and Chinese, order also the local language bezel as shown in the previous "List of Parts"	Not shown

*The new M3015 hardware offers an improved warm up time compared to the old hardware and the gas sample flow rate specification has been changed to 50 ml/min -7,5ml/min/+15 ml/min. Also, the Suppress Auto Zero feature and the capability to turn off the M3015A pump have been added. The new hardware is backwards compatible with all MP20-90 host monitors, but the new features will only be available in combination with a monitor with SW Rev. B.1 or higher.

Smart Battery Charger Part Numbers

Exchange Assemblies

Exchange Part No.	12NC (Exch.)	Description
M8043-68000	453563498911	Exchange Smart Battery Charger

Non-Exchange Assemblies

Exchange Part No.	12NC (Exch.)	Description
M8043-60010	451261001281	Replacement Kit: Air Fan & 2 Filter Mats
M8043-60011	451261001291	Replacement Kit: 2 Filter Mats

Installation Instructions

Installation should be carried out by qualified service personnel, either by the hospital's biomedical department, or by Philips Support.

If you have purchased a “customer-installable bundle”, it is assumed that your own hospital personnel will install and, if necessary, configure the monitor. You can contact Philips Support for assistance if required; any assistance will be associated with additional costs.

For mechanical and electrical installation, you need technically qualified personnel with a knowledge of english. Additionally, for monitor configuration, you need clinically qualified personnel with a knowledge of the use environment.

WARNING

- Monitor configuration settings must be specified by authorized hospital personnel.
 - As the first step in preparing the monitor for use, follow the installation instructions given in this chapter.
-

Out-Of-Hospital Transport - Standards Compliance

The MP2 patient monitor and the X2 Multi-Measurement Module/patient monitor, with the following measurements and interfaces:

- ECG/Respiration, NBP, SpO₂, Pressure, Temperature, CO₂ (only Mainstream Sensor M2501A)
- LAN, Battery

can be used in a transport environment such as a road ambulance, airplane or helicopter. For this purpose the monitor fulfils the following additional mechanical, EMC and environmental requirements:

- **Shock Tests** according to IEC TR 60721-4-7, Class 7M3. Test procedure according to IEC/EN 60068-2-27 (peak acceleration up to 100 g).
- **Random Vibration** according to IEC TR 60721-4-7, Class 7M3. Test procedure according to IEC/EN 60068-2-64 (RMS acceleration 5 g).
- **Sinusoidal Vibration** according to IEC TR 60721-4-7, Class 7M3. Test procedure according to IEC/EN 60068-2-6 (acceleration up to amplitude 2 g).
- **Bump Test** according to IEC/EN60068-2-29 (peak acceleration 15 g, 1000 bumps).
- **Free Fall Test** according to EN1789 (covers also IEC TR 60721-4-7 and Class 7M3). Test procedure according to EN 60068-2-32 (height 0.75 m).
- Specification for degrees of protection provided by enclosures according to **IEC/EN 60529: IP 32**
- **EN 1789 +A1:2003** Medical vehicles and their equipment - Road ambulances (chapter 6 - Medical Devices).

NOTE

In order to be compliant with EN 1789 +A1:2003, the appropriate mounting device must be used.

- **Radiated susceptibility 20 V/m** according to EN ISO 9919 (SpO₂) and EN ISO 21647 (CO₂).
- **Altitude Range** from -500 to 3000 m operating and -500 to 4600 m storage and transportation.
- **Extended radiated susceptibility** tests

The MP2 patient monitor with its out-of-hospital parameter set provides a general immunity level of 20 V/m with only few restrictions. Details are as listed below:

The X2 Multi-Measurement Module/patient monitor with its out-of-hospital parameter set provides a general immunity level of 20 V/m with only few restrictions. Details are as listed below:

- GSM 900: Immunity at 900 MHz (uplink mobile phone), 20 V/m (ECG:10V/m), duty cycle 1:8
- GSM 1800: Immunity at 1800 MHz (uplink mobile phone), 20 V/m, duty cycle 1:8.
- DECT: Immunity at 1800 MHz (digital cordless phone), 20 V/m, duty cycle 1:24
- AM: 1 kHz Immunity from 80 MHz to 1.0 GHz (any radio communication unit, broadcasting and TV transmitter), 20 V/m, modulation factor 80 %. (ECG: 20 V/m except 600-950 MHz where it is 10 V/m and Temperature which holds 3 V/m over the full range).

CAUTION

Temperature measurement accuracy may be compromised in the presence of strong electromagnetic fields (>3 V/m) in certain small frequency bands.

- **Operating ambient temperature** testing over the range from 0 to 40°C (32 to 100°F).
- **Operating ambient humidity** testing up to 95 % RH at 40°C (100°F), non condensing.

NOTE

Additional requirements can be necessary for transport situations in air, on water or in difficult terrain in certain countries, e.g. EU.

Electromagnetic Interference (SRR)

Commercially available Short Range Radio 802.15.4 transceivers operate at very low RF power levels to transmit data and need to have high sensitivity receivers to achieve a good link budget. Due to technological limitations the selectivity of the receiver is limited. Consequently, the SRR link is susceptible to other strong RF transmitters not only in the operating frequency band and 5% around it, but also to non-transient RF disturbances stronger than 1V/m at frequencies close to the operating frequency band (2.0 to 2.3 GHz)

Installation Checklist

Use this checklist to document your installation.

Step	Task	Check Box when Task Done
1	Perform initial inspection of delivery, unpack and check the shipment	<input type="checkbox"/>
2	Mount the monitor as appropriate for your installation	<input type="checkbox"/>
3	Connect the monitor to AC mains via the external power supply using the supplied power cord or connect the MP2/X2 to a host monitor	<input type="checkbox"/>
4	Perform Visual, Power On and Functional test blocks	<input type="checkbox"/>
5	Perform Safety Tests, if required by local laws and regulations	<input type="checkbox"/>
6	Check/set the time and date	<input type="checkbox"/>
7	Check that the country-specific default settings are appropriate	<input type="checkbox"/>
8	Perform System Test as necessary	<input type="checkbox"/>

Unpacking and Checking the Shipment

The monitor and any supporting options ordered are supplied packed in protective shipping cartons.

Initial Inspection

Before unpacking, check the packaging and ensure that there are no signs of mishandling or damage.

Open the package carefully and remove the monitor and accessories.

Check that the contents are complete and that the correct options and accessories have been delivered..

System Components, Accessories and Supplies	Comments
Monitor with options as ordered	1
ECG accessories	optional
NBP accessories	optional
SpO ₂ accessories	optional
Pressure accessories	optional
Temperature accessories	optional
CO ₂ Accessories	optional
External Power Supply including AC power cord and MSL cable	1
External Power Supply including AC power cord and MSL cable	optional
Rechargeable battery	1
Instructions for Use	1
Quick Guide	1
Documentation CD-ROM (includes Service Guide and Instructions for Use)	1

Claims for Damage

If the shipping cartons are damaged, contact the carrier.

If any of the equipment is damaged, contact both the carrier and your local Philips service organization for repair or replacement arrangements.

Repacking

Retain the original packing carton and material, in case you need to return equipment to Philips for service. If you no longer have the original packing materials, Philips can advise you on alternatives.

Mounting the Monitor

Every type of compatible mounting solution is delivered with a complete set of mounting hardware and instructions. Refer to the documentation delivered with the mounting hardware for instructions on assembling mounts.

WARNING

- It is the customer's responsibility to have the attachment of the mounting hardware to the ceiling, wall, or mounting rail and the construction of the ceiling, wall, or mounting rail evaluated for structural integrity and compliance with all local, state and any other required codes by a registered, professional, structural and/or mechanical engineer.

Ensure that this commitment has been met before assembling mounts.

- Incorrect mounting and use of inappropriate mounting material may lead to injury. It is the customer's responsibility to ensure that the mounting procedures have been performed correctly and the appropriate mounting devices have been used.
-

Mounting the Monitor using the Anti-slip Pad

1. Place the anti-slip pad on a level surface. Optionally, the anti-slip pad can be secured with screws.



2. If you are using extensions with your MP2/X2 leave the anti-slip pad as is and insert the monitor.



3. If you are using an MP2/X2 without extensions, fold the back flap of the anti-slip pad backwards and insert it into the slots as shown below. Then place the MP2/X2 onto the anti-slip pad.

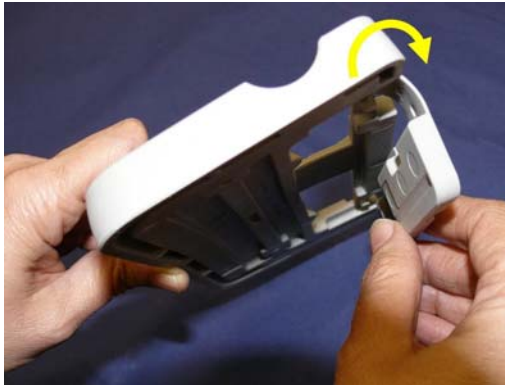

Mounting the Monitor using the MMS Mount and Mounting Clamp

Attach the universal mounting clamp to the MMS mount and the mount the MSL cable in the cable clamp according to the following instructions to ensure that the cable is attached permanently. Do not remove the MSL cable from the cable clamp.



MMS mount with cable clamp - rear view (without universal mounting clamp handle)



MMS mount with cable clamp - front view (with universal mounting clamp handle)

1. Attach the universal mounting clamp to the mount with two M4x16 screws either in horizontal or vertical position to suit your installation.



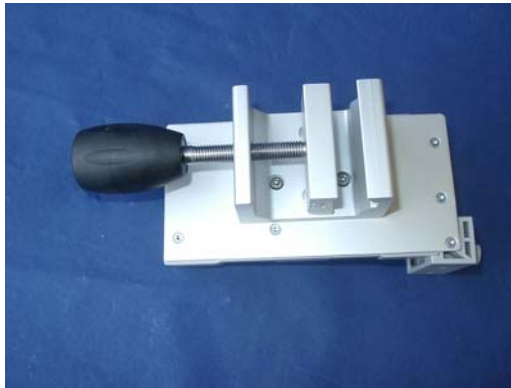
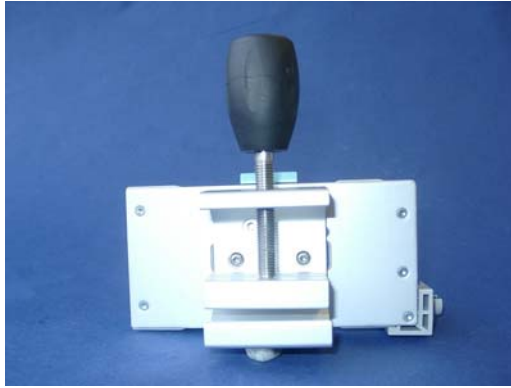

2. To install the MP2/X2, place the MSL cable (1) on the clamp (2), as shown in the picture. Use the visual guide (3) and the positioning notch (4) to ensure you have the cable correctly positioned.

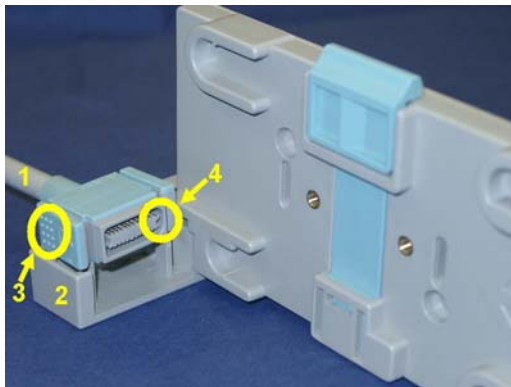

3. Squeeze the side clips (1) open slightly and ease the cable into the clamp so that the clips grip the gray pillars (2). Press the cable down firmly to ensure that it is fully seated in the clamp.

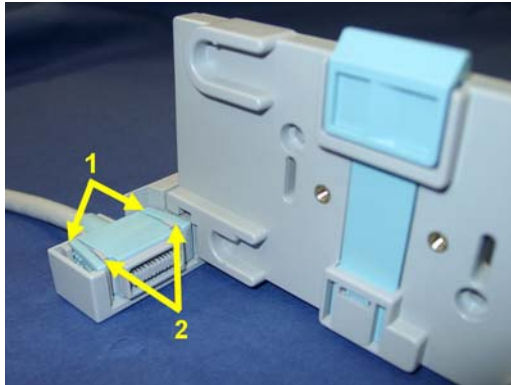

4. Align the feet on the MP2/X2 with the locating shoes (1) on the mounting plate and slide the MP2/X2 onto the mounting plate.



5. Ensure that the cable is securely fixed to the MP2/X2. Once fixed, do not remove the cable from the MMS clamp.



Mounting the Monitor onto the Rollerstand

1. The monitor can be attached to the rollerstand as shown below. For details see the IfU provided with the rollerstand.



Mounting the MMS Mount to the FMS (M8048A)

1. Connect the MMS Mount to the FMS and snap it into place.



2. Insert and tighten the screw at the bottom of the FMS

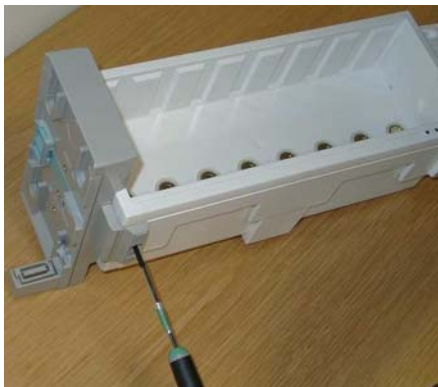

Connecting the Monitor to AC Mains

The monitor is an electrical Class II device in which the protection against electric shock does not rely on basic insulation and a protective earth conductor but on double and/or reinforced insulation.

Host Monitor as Power Source

When connected to a host monitor, via the Measurement Link (MSL) cable or when directly attached to the host, the X2 obtains its power from the host, including that needed for battery charging. Note that the X2 will operate and charge its battery even when attached to a host monitor running on battery power.

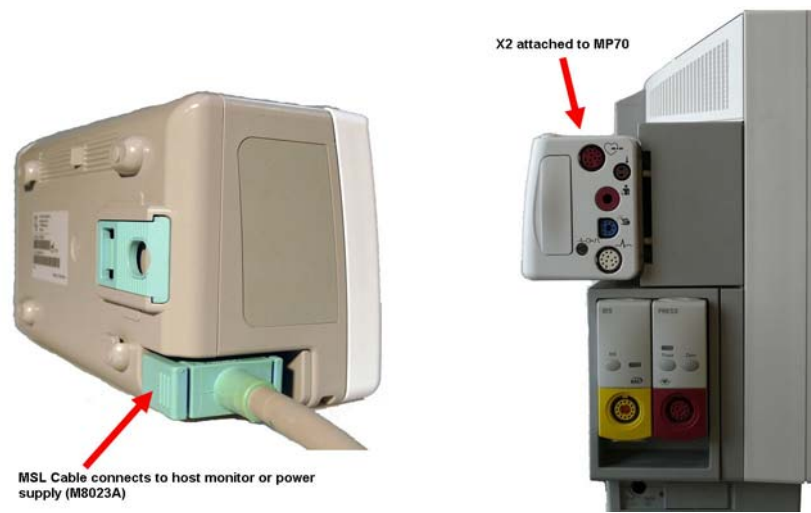

External Power Supply M8023A(Standard with MP2, Optional with X2)

The optional wide-range external power supply (M8023A) allows you to operate the monitor from an AC (alternating current) power source of 100 V to 240 V ($\pm 10\%$) and 50 to 60 Hz ($\pm 5\%$). The external power supply also charges the monitor's battery.

The monitor has a wide-range external power supply (M8023A) that allows you to operate the monitor from an AC (alternating current) power source of 100 V to 240 V ($\pm 10\%$) and 50 to 60 Hz ($\pm 5\%$). The external power supply also charges the monitor's battery.

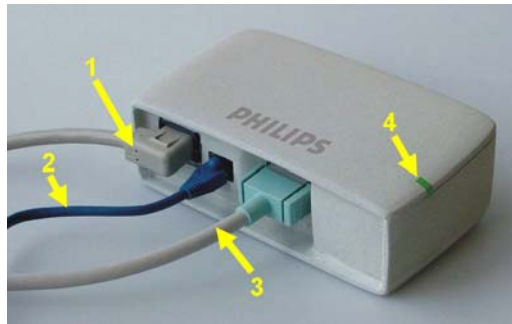

1	AC power cord. Connect to AC mains socket.
2	Connect LAN cable here. For connection to a PC or Central Station.
3	Measurement Link (MSL) cable. Supplies DC input power to the monitor for AC operation and for battery charging. The MSL cable is also used to communicate with a PC or Information Center.
4	Power-on LED. The green light is on when the external power supply is connected to AC mains.

WARNING

- Always use the supplied power cord with the earthed mains plug to connect the external power supply (M8023A) to an earthed AC mains socket. Never adapt the mains plug from the power supply to fit an unearthed AC mains socket.
- Do not use AC mains extension cords or multiple portable socket-outlets. If a multiple portable socket-outlet without an approved isolation transformer is used, the interruption of its protective earthing may result in enclosure leakage currents equal to the sum of the individual earth leakage currents, so exceeding allowable limits.
- Do not connect any devices that are not supported as part of a system.
- Any non-medical device placed and operated in the patient's vicinity must be powered via an approved isolation transformer that ensures mechanical fixing of the power cords and covering of any unused power outlets.
- The grub screws at the bottom of the external power supply are not internally connected to ground.

Checking Out the Monitor

The following table defines which tests and inspections need to be performed, and when they are required.

Test	Test or Inspection to be Performed
Visual	Inspect the monitor, measurement accessories and cables for any damage. Are they free of damage?
Power On	Power on the monitor. Does it start up successfully without errors? Do all alarm lamps light up during power up? After start up, the monitor sounds a tone, and you can see the monitoring main screen (normally with measurement wave channels and numeric positions).
Functionality Test	After power up, touch the battery status indicator in the bottom right of the screen. The battery status window should open. Press the blue Main Screen key to close the window and return to the main screen.
Safety Tests (1) to (4)	Perform safety tests (1) to (4), as described in the <i>Testing and Maintenance chapter</i> , for standalone devices if required by local laws and regulations, and each time you combine equipment to form a system, or exchange system components. Details of the safety tests and procedures are described in the <i>Testing and Maintenance chapter</i> . These safety tests are derived from international standards but may not always be sufficient to meet local requirements.
System	Perform the system test according to IEC 60601-1-1, if applicable, after combining equipment to form a system (see the <i>Testing and Maintenance chapter</i>).

For test and inspection information regarding repairs, upgrades and all other service events, refer to the *Testing and Maintenance chapter*.

Configuration Tasks

You must configure these settings during installation in configuration mode.

- Line Frequency
- Altitude
- Equipment Label (for wireless networked monitors, or when the Information center is in flexible monitoring mode).
- IP Address, Subnet Mask and Default Gateway (for manual IP Address Configuration - only in **service mode**)
- ECG cable colors
- Height and Weight units
- IGMP, CI Mode, CI Address, CI TTL (for Customer Supplied Clinical Network (CSCN) Routed Bedside Configurations) - only in **service mode**)

Checking Country-Specific Default Settings

Some settings are made in the factory to match the typical requirements in a specific country. Line frequency, units for weight and height, and ECG cable colors (AAMI or IEC) have been set to appropriate values. If you suspect that these settings may not match your institution's requirements, check the settings and change them if necessary as described in the *Configuration Guide*.

WARNING

Before starting monitoring, check that the configuration meets your requirements, especially patient category, alarm limits and paced setting.

If you need to enter configuration mode:

1. In the **Main Setup** menu, select **Operating Modes**.
2. Select **Config** and enter the passcode.
The passcode for configuration mode is given in the monitor's service documentation.

The monitor displays **Config** at the right hand side of the status line and in the center of the Screen while you are in configuration mode.

Before you leave configuration mode, always be sure to store any changes you made. You must store changes made to each Settings Block and to each Profile, individually. As it may be difficult to remember whether the settings you changed belong to a Monitor Settings block or a Measurement Settings block, we recommend that you store each block before you leave configuration mode.

To leave configuration mode:

- ▶ In the **Main Setup** menu, select **Operating Modes** and then select **Monitoring**.

Setting Altitude, Line Frequency, ECG Cable Colors and Height & Weight Units

You require a local barometric pressure rating from a reliable source (such as airport, regional weather station, or hospital weather station) that is located at the same altitude as the institution.

1. From the **Main Setup** menu, select **Global Setting**. Select **Altitude** and enter the altitude.
2. From the **Main Setup** menu, select **Global Setting**. Select **Line Frequency** and choose the Line Frequency.
3. From the **Main Setup** menu, select **Global Setting**. Select **ECG Cable Color** and choose the Cable Color.
4. From the **Main Setup** menu, select **Global Setting**. Select **Height Unit** and choose the Height unit.
5. From the **Main Setup** menu, select **Global Setting**. Select **Weight Unit** and choose the Weight unit.

Configuring the Equipment Label

If the Information Center is in fixed monitoring mode, it controls the equipment label. You do not need to follow this procedure.

However, if you are on a wireless network, or your Information Center is configured for flexible monitoring mode, you must set the equipment label. This associates the monitor with a central monitoring sector. An identical monitor label must also be configured in the Information Center.

1. Select the **Bed Label** screen element to call up the **Bed Info** menu.
2. Select **Equipment Label** to call up the onscreen keyboard.
3. Enter the system identifier. This needs to be set up in either the monitor or the information Center. If the Information Center is in flexible monitoring mode, the monitor must be setup to match the Information Center's monitor label.

Configuring IP Address, Subnet Mask and Default Gateway

Typically the automatic configuration via the BOOTP Server of the central station is used. In this case all fields are set to 0.0.0.0. For special requirements, it is possible to switch to a manual/fix IP address configuration.

NOTE

- Only limited checks of the manual values are possible. Therefore, it is mandatory that a manual configuration is only performed by an experienced service person to avoid problems such as duplicate IP addresses, non matching subnet mask, etc.
 - The second CPU of an MP90 does not support a manual configuration and therefore will always request the IP configuration via BOOTP.
1. Select the **Bed Label** screen element to call up the **Bed Info** menu.
 2. Select **IP Address**. If the IP Address is set to 0.0.0.0, all values are dynamically requested from a BOOTP Server. Otherwise the manually entered address is used.
 3. Select **Subnet Mask**. The Subnet Mask must be provided for manual IP addresses. The Subnet Mask must consist of a single consecutive series of "1" bits; e.g. 255.255.248.0. The configured value is ignored when the IP Address is provided by a BOOTP Server.
 4. Select **Default Gateway**. The IP Address of the Default Gateway can be optionally configured. The configured value is ignored if IP Address and gateway are provided by a BOOTP Server. The configured value must be within the range of the Subnet Mask.

Configuration Settings for CSCN Routed Bedside Monitors (RBM)

The following settings are used for Customer Supplied Clinical Network (CSCN) Routed Bedside monitors. To access these settings, select the **Bed Label** screen element to call up the **Bed Info** menu.

IGMP: Shows status of IGMP Support (On or Off). IGMP (Internet Group Multicast Protocol) is used by many switch manufacturers to limit the number of destinations targeted by a multicast packet.

CI Mode: The mode in which CI messages (Connect Indication messages) are send (Broadcast, Multicast, Manual).

CI Address: IP Address for Connect Indication messages only being used if CI Mode is set to Manual. If CI Mode is Broadcast the CI Address is implicitly the subnet broadcast address. If CI Mode is Multicast the CI Address is implicitly 224.0.23.63.

CI TTL: Sets the TTL (Time To Live) of the CI message. Defaults to 1.

Configuring Routed Bedside Monitors Support

An IntelliVue MP2/X2, MP5/MP5T or MP20-90 monitor must be running software revision level G.0 or higher to be used as a routed bedside monitor (RBM).

CAUTION

A Philips Routed Bedside Monitor may temporarily stop displaying its Care Group overview bar for up to 60 seconds if a network link carrying multicast traffic between the Philips IntelliVue Information Center and the network routers is lost. While the multicast traffic is being re-routed, the monitor will not display the Care Group overview bar but will maintain connectivity to its associated Philips IntelliVue Information Center. Primary monitoring/alarms will remain available at the Routed Bedside Monitor and its associated Philips IntelliVue Information Center while the multicast traffic is being re-routed.

To configure an IntelliVue Patient Monitor to function as an RBM:

1. Put the monitor into Service Mode
2. Select Main Setup => Bed Information => IGMP and set IGMP to On.
3. Select Main Setup => Bed Information => CI Mode and set CI Mode to Multicast.
4. Select Main Setup => Bed Information => CI TTL, and set CI TTL to a value of 8.
5. Store the settings.
6. The CI Address will change to 224.0.23.63.
7. Return the monitor to its normal operational mode.

For further information regarding CSCN Routed Bedside Monitors refer to the CSCN Specifications (P/N: 4535 640 24951)

Setting the Date and Time

To set the date and time:

1. Select the **Main Setup** SmartKey to enter the Main Setup menu.
2. Select the **Date, Time** screen element from the monitor's info line to enter the **Date, Time** menu.
3. Select, in turn, the **Year, Month, Day, Hour** (in 24 hour format, only) and **Minute** as necessary. Select the correct values from the pop-up list.
4. Select **Store Date, Time** to change the date and time.

If your monitor is connected to an Information Center, the date and time are automatically taken from this.

If the X2 is connected to a host monitor, the date and time are automatically synchronized with the host monitor. When connected to a host monitor, you cannot set the date and time on the X2.

Once it is set, the internal clock retains the setting even when you switch off the monitor.

Handing Over the Monitor

If you are handing over the monitor to the end-users directly after configuration, make sure that it is in Monitoring mode.

Ensure that the users have access to the following documentation delivered with the monitor:

- Training Guide - for self-training on the monitor before use
- Quick Guide - for quick reminders during use
- Instructions for Use- for full operating instructions

WARNING

All users must complete the training program before working with the monitor.

These training materials (in combination with this service guide) can also be used to train service personnel on how to use and service the MP2/X2 monitor.

Philips Clinical Network (Wired)

Installation of the Philips Clinical Network should be performed by Philips service personnel. Use unshielded twisted pair (UTP) cables for installation of the clinical network. Refer to the installation instructions in the M3185A Installation Manual for further details.

Philips IntelliVue Information Center

Please refer to the installation instructions and Instructions for Use of the IntelliVue Information Center Rev. System J or higher.

IntelliVue Instrument Telemetry (IIT)

Frequency Coordination (USA only):

Frequency coordination is a registration and coordination process for wireless medical telemetry devices used in the U.S.A. which operate in the FCC-allocated Wireless Medical Telemetry Service (WMTS) bands (608-614 MHz, 1395-1400 MHz, 1427-1432 MHz). The M8102A/M3002A #J45 operates in both of the 1395-1400 and 1427-1432 MHz bands.

Under U.S. Federal Communications Commission (FCC) rules, authorized healthcare providers must register their WMTS devices with an authorized Frequency Coordinator designated by the FCC. The American Society for Healthcare Engineering (ASHE) is the current designated Frequency Coordinator.

Registration/Coordination is a two-step process.

Step 1: Registration: Register the healthcare facility on-line, from the ASHE website (www.ashe.org (<http://www.ashe.org/n>)). Click on the link for Wireless Medical Telemetry Service and come to the registration page. Fill out the details, and pay the associated fee as per the instructions provided. You will receive confirmation of this registration. Confirmation must be received before proceeding to the next step.

Step 2: Frequency Coordination: Along with confirmation of registration, you will receive access information necessary to perform this second step, frequency coordination. This step involves logging the equipment and frequencies used into the FCC's database, so as to identify any existing potential interference and to help prevent potential future interference. Coordination is accomplished via the ASHE website. Click on the links for Wireless Medical Telemetry Service and then Frequency Coordination. The way the coordination process is executed as of today, **it will need to be repeated twice** for the M4840A system; once for the 1395-1400 MHz band, and then again for the 1427-1432 MHz band, both of which are used concurrently by the Philips product. There is a separate fee for each coordination request, which varies between \$250 and \$2000, depending upon the number of transmitting devices used and the band/s of operation. Coordination is executed by a company named Comsearch, on behalf of ASHE.

To fill in the frequency coordination forms, you'll need to know the following:

- The county.
- Latitude and longitude that represents the center of the area where the transmitting devices will be deployed. Comsearch can help provide this information; www.comsearch.com provides contact information.
- The name/s of the Clinical Unit/s using the devices (e.g. ICU4, CCU-West, ER1, Step-Down North, etc).
- The radius of deployment, expressed in meters. Imagine drawing a circle around the center of the clinical unit, that encloses/encompasses the unit. What is its radius?
- The number of the highest floor on which a transmitting device will operate.
- How many transmitting devices will be used, i.e. the total number of IntelliVue Instrument Telemetry adapter devices combined.
- The Effective Radiating Power: 6.3 mW.

- The Equipment Manufacturer: Philips Medical Systems.
- The Model numbers: M8102A/M3002A #J45 IntelliVue Instrument Telemetry adapter used with M8102A/M3002A (MP2/X2)
- The Frequency Range to be used: Two separate coordinations are required: For the first one, click on the range of 1395.0 through 1400.0 MHz. For the second one, click on all the frequency ranges listed in the range of 1427.0 through 1432.0 MHz.

When both Registration and Frequency Coordination have been successfully completed, the IntelliVue Instrument Telemetry System can be activated. Note that this process is the responsibility of the customer, as the final “operator” of the transmitting equipment.

Short Range Radio

Installation of the Short Range Radio interface should be performed by Philips service personnel. Before installing an SRR infrastructure it might be necessary to perform a site survey to determine available channels. This should be performed by Philips telemetry installation experts.

Configuring SRR Channels

Hardware Setting: **Main Setup -> Hardware -> SRR Channel**

SRR channel settings only apply for monitors that have a short range radio interface installed. They must be set to match the hospital’s wireless infrastructure. SRR channel settings are hardware settings and will typically be set by service personnel at installation.

Refer to your configuration guide for details.

SRR Channel Settings Configuration Implications

Channel Use this setting to configure the SRR channel the monitor should use. SRR provides a total of 16 channels in the ISM (2.4 GHz) band. The channels are labeled 11 to 26. Up to two SRR connections can be established per channel. The ISM band is not exclusively reserved for SRR applications. It is also used by, for example, Wireless LAN (WLAN) and the IntelliVue Telemetry network (except for the US). For this reason, depending on the hospital's existing wireless infrastructure, a number of SRR channels might already be occupied by other wireless applications.

To achieve the best SRR performance possible, follow these recommendations:

- Usage of WLAN together with SRR may cause interferences. Each WLAN network uses at least four of the 16 SRR channels. If the use of WLAN cannot be avoided, limit the number of channels used for the WLAN infrastructure to a minimum.
- Usage of Bluetooth devices together with SRR may cause interferences. Bluetooth devices automatically change channels regardless of whether a channel is already used by another component of the wireless infrastructure and therefore interfere with SRR connections.
- Usage of cordless phones using the ISM band in the vicinity of SRR devices may cause interferences.
- Usage of wireless PC keyboards or mice using the ISM band in the vicinity of SRR devices may cause interferences.

To assign SRR channels to all monitors in a unit that should be used with SRR connections,

1. Identify unused SRR channels. This can be done by using commercially available tools, such as AirMagnet.
2. Obtain a floor plan of the unit and identify where the monitors with SRR interface are located.
3. Determine SRR groups. An SRR group may contain a maximum of two monitors which share the same SRR channel. Monitors belonging to an SRR group should be located close to each other.
4. For each SRR group, assign the same SRR channel to all monitors belonging to a group.

SRR Channel Restrictions with WLAN, IIT, and DECT Devices

The following table and graphic show the restrictions of WLAN, IIT, or DECT Device usage together with SRR.

US WLAN (802.11)	1				6						11						
Europe WLAN (802.11)	1				7						13						
IIT 2.4 GHz (Smart Hopping Channels)	0 - 13				14	15 - 30						29 - 47					
SRR (802.15.4)	11 2405 MHz	12 2410 MHz	13 2415 MHz	14	15	16	17	18	19	20	21	22	23	24	25	26 2480 MHz	

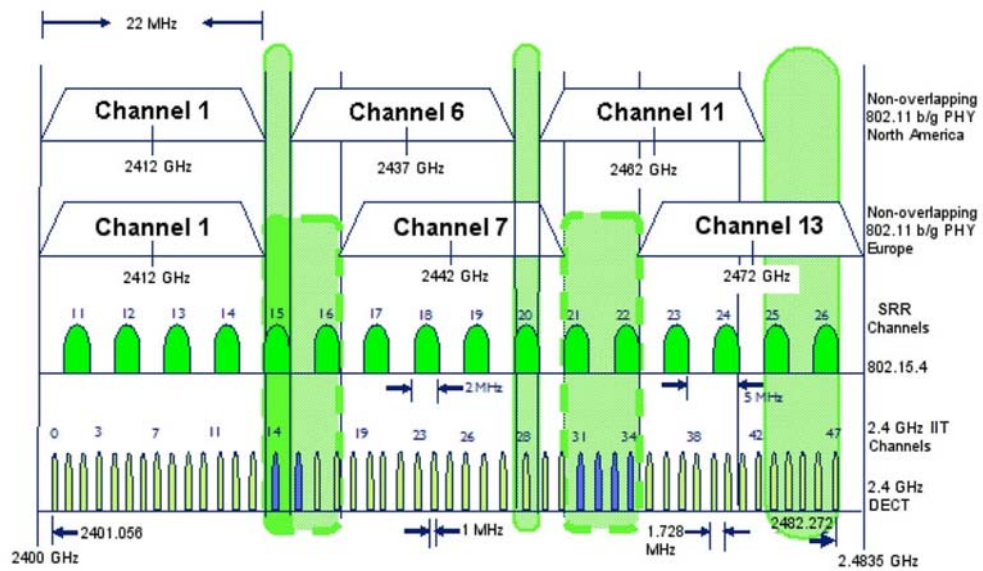

For a successful SRR deployment, the SRR channels must be located in RF spectra where they are least likely to be interfered with. Choosing appropriate channels after reviewing the Spectrum Analyzer data is critical. In hospitals, 802.11 systems are most the likely source of interference with SRR channels. The figures above show the relationship between 802.11, IIT, and DECT Devices. For example, if the site uses European 802.11 channel 1 for WLAN and has no IIT or DECT devices in the SRR channels 15 or 16, these channels can be used for SRR. Philips telemetry experts will identify available SRR channels by performing a site survey.

When using the Philips IntelliVue 802.11 Bedside Adapter we recommend that you use the 5 GHz band to free the 2.4 GHz band for SRR usage.

NOTE

Short range radio signals are low power signals and therefore have a relatively short range. You can use this fact if the number of unused channels is low, and you run out of channels. Provided the distance between two SRR groups is large enough, i.e. none of the short range radio signals transmitted by the one group can interfere with signals of the other group, you may attempt to assign the same SRR channel to both groups. Take into consideration that portable components (such as Telemetry transceiver, MP5/MP5T or an X2) belonging to one group may be temporarily used within the range of another group.

The range of SRR signals cannot be clearly defined as it depends on external factors such as the components and structure of walls, ceilings, etc.

ECG Sync Pulse

The ECG-Sync pulse is output only if a corresponding cable is detected. The detection of the cable is made by bridging two pins. Note that the ECG Pulse drives inputs with a resistance of 3 kOhms or higher. The rectangular ECG Pulse is active high (approximately 3.3V) for 100ms and low (approximately 0V) for the rest of the time.

ECG Pulse Client	Pin and Signal Direction	MP2/X2 monitor
GND	5 <=>	GND
ECG Pulse	1 =>	ECG Pulse
Cable detect: bridge pins 3 and 5, connect directly	5 <=	Cable detect

Provide a clean ECG signal (from patient or simulator) to the monitor. Then connect the cable to the monitor and check that marker pulses are shown on the screen. At last connect the cable to the ECG Pulse Client and process the signal.

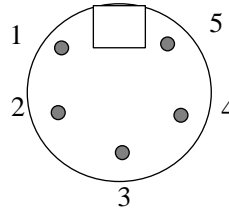

Monitor Output

MSL Cable Termination

The following installation procedure describes how to install the wall installation cable kit when the X2 and the host monitor are not located at the same site. The kit consists of two connector boxes and a cable (15m or 25m).

For this procedure you need the insertion tool (M3086-43801) and a small screwdriver.

1. Draw the MSL cable through the wall from the site of the monitor to the site of the measurement server.

Each MSL face plate kit contains two connector boxes; one in-going and one out-going. (The US version contains an additional rectangular wall-mounting plate).

NOTE

The installation procedure is the same for both connector boxes. This means you must perform steps 3 to 8 of this procedure twice.

The connectors on each box are different, so you must ensure that the correct box is placed at the correct location. The dots on the plastic angled cover indicates at which site you should install the box:

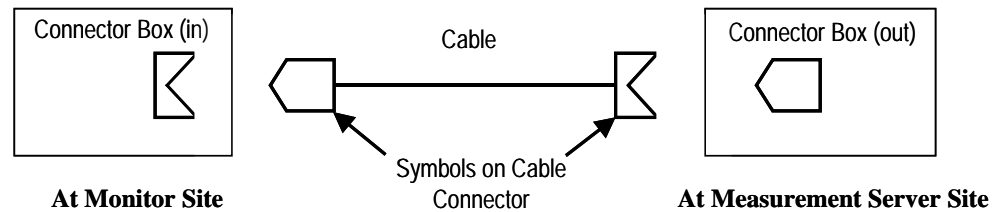
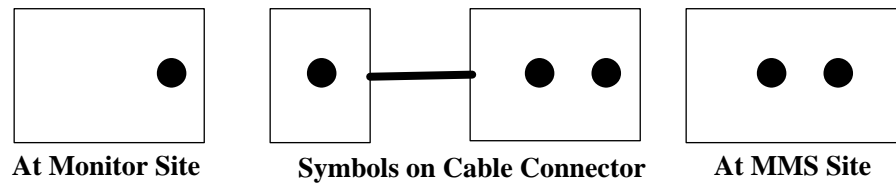

If there are no dots on the cover, symbols are used:

Symbol:  is connector box (in) and must be placed at the monitor site.

Symbol:  is connector box (out) and must be placed at the measurement server site.

The correct connector cable (M3081-61601, M3081-61602 or M3081-61603) has the opposite symbol:

2. Detach the PCB assembly (in/out) from the metallic mounting flange.
3. Use the Insertion Tool (M3086-43801) to position each wire on the PCB according the wiring schematic in , where each color corresponds to a number.

NOTE

The Insertion Tool should be set to cutting mode &= on.

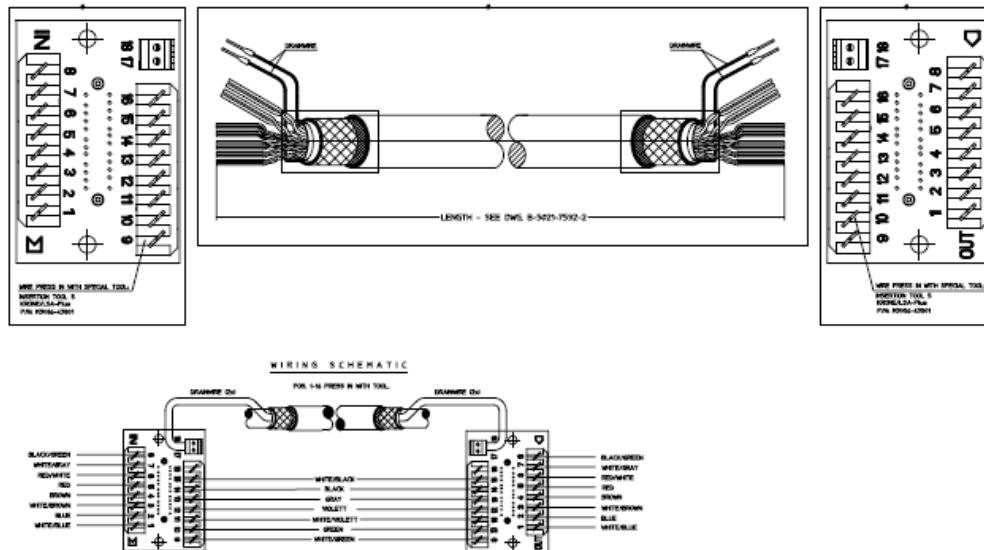
**Wiring Schematic**

4. Use a small screwdriver to connect the two drain wires to the PCB, see the wiring schematic in .
5. Slide the PCB back on to the metallic mounting flange.
6. Use screws to fasten the mounting flange to the wall.

NOTE

US version only: Fasten the rectangular wall-mounting plate to the wall. Attach the mounting flange to the wall-mounting plate.

7. Mount the plastic cover. The plastic cover consists of two pieces:
 - Frame
 - Angled cover

Put the frame over the mounting insert and the PCB. Place the angled cover on top and fasten with two screws.
8. Connect the monitor and the measurement server to the wall installation.
9. Perform the following tests as described in the Test and Maintenance section of this manual:
 - Power-on test blocks
 - Safety test blocks
 - ECG Sync Performance Test

Site Preparation

Introduction

This section describes the procedures you should follow to plan and prepare a site for an MP2/X2 monitor installation. It describes:

- Site planning.
- Roles and responsibilities for local and Philips personnel.
- Remote installation planning.

Site Planning

The careful planning of the site for the MP2/X2 monitor is essential for its safe and efficient operation. *A consulting schedule should be established between the Customer and Philips Sales and Support Representatives, to ensure that all preparations are completed when the system is delivered.*

The site planning phases prior to equipment installation are:

Location: Planning the location of the various system components.

Environment: Confirming and correcting, as necessary, the environment of the proposed installation site(s).

System Capabilities: Explaining the possibilities for system expansion.

Mounting: Referencing the mounting hardware information website for the listing of suitable mounting hardware recommended for use with the various system components, and all details on the available mounts and accessories.

Cabling: Identifying the requirements for the cabling, conduiting and faceplates for connecting the various system components.

Roles & Responsibilities

This section describes the procedures necessary to prepare a site for a system installation. The procedures are grouped into two parts: procedures that local staff or contractors are responsible for, and procedures that Philips personnel are responsible for.

Site Preparation Responsibilities

Local Staff

- Ensure that all safety, environmental and power requirements are met.
- Provide power outlets.
- Prepare mounts.
- Pull cables, install conduit, install wallboxes.
- Terminate network cables if a Philips Clinical Network is in use.
- It may be necessary to certify the network cable plant, see Philips Clinical Network Installation Manual for details.

Alternatively, the following procedures can be performed by Philips Personnel

- Provide the customer with the safety, environmental and power requirements.
- Assemble mounts.
- Prepare monitor remote cabling.

Procedures for Local Staff

The following tasks must be completed **before** the procedures for Philips personnel may be started.

- Providing Power Outlets

One power outlet for each display and for any peripheral device (for example, a printer or slave display) is required by the system. Provide a power outlet in the vicinity (1 m or 3 ft.) of each component that requires power.

WARNING

Only the power cables provided with the system may be used. For reasons of safety, power (mains) extension cables or adapters shall not be used.

- Preparing Mounts

Where ceiling, wall, or shelf mounts are required for mounting the equipment, the customer is responsible for the following:

- Providing and installing all hardware which is required to install the mounting hardware supplied by Philips as detailed in the installation notes.
- Making sure that all ceilings, walls, and mounting rails that supports mounting hardware are suitable for their proposed load.

WARNING

It is the customer's responsibility to have the attachment of the mounting hardware to the ceiling, wall, or mounting rail and the construction of the ceiling, wall, or mounting rail evaluated for structural integrity and compliance with all local, state and any other required codes by a registered, professional, structural and/or mechanical engineer.

Although considerable effort has been made to ensure the safety of the ceiling mount installation and or mounting guidelines, it is to be understood that the installation itself is beyond the control of Philips Medical Systems. Accordingly, Philips Medical Systems will not be responsible for the failure of any such installation.

- Providing Conduit

Where a remote installation is required, for example the installation of a remote display, the customer is responsible for the following hardware installations:

- Providing conduit and/or trunking of a sufficient cross-sectional area for the planned cables and possible future expansion (for additional components or systems).
 - Providing and/or installing suitable wall boxes to accommodate the faceplates.
- ### - Pulling Cables

WARNING

NEVER run power cables through the same conduit or trunking used for system cables.

- Installing Wall Boxes

It is the customer's responsibility to provide and install wallboxes to house faceplates. The customer must notify the Philips installation coordinator of which size is to be used.

- Install the MP2/X2 monitor using the appropriate mounting solution and perform the installation procedures as described in the Installation section.
- Hand over the monitor to the end-users as described in *Handing Over the Monitor* in the Installation section

WARNING

Incorrect installation, mounting and use of inappropriate mounting material may lead to serious injury. It is the customer's responsibility to ensure that the mounting procedures have been performed correctly, the appropriate mounting devices have been used and the monitor has been installed and configured correctly.

Procedures for Philips Personnel

Before you begin the procedures in the installation sections, ensure that the customer has completed all necessary preparations outlined in the previous section, "Procedures for Local Staff."

- Install the MP2/X2 monitor using the appropriate mounting solution and perform the installation procedures as described in the Installation section.
- Hand over the monitor to the end-users as described in *Handing Over the Monitor* in the Installation section

Monitor Site Requirements

Space Requirements

The siting of the monitor should be planned such that the nursing staff are able to monitor the patient with relative ease, with all patient connectors and controls readily available and the displays clearly visible. The location should also allow access to service personnel without excessive disruption and should have sufficient clearance all round to allow air circulation.

Dimensions and weight:

Size (W x D x H)

188 x 86 x 99 mm (7.4 x 3.39 x 3.9 in)

Weight (with standard measurement and battery)

1.5 kg (3.3 lb.)

Environmental Requirements

The environment where the MP2/X2 monitor will be used should be reasonably free from vibration, dust and corrosive or explosive gases. The ambient operating and storage conditions for the MP2/X2 monitor must be observed. If these conditions are not met, the accuracy of the system will be affected and damage can occur.

Temperature

Operating: 0 to 40°C (32 to 100°F)

Storage: -20 to 60°C (-4 to 140°F)

when equipped with IntelliVue Instrument Telemetry (IIT) and while charging batteries:

Operating: 0 to 35°C (32 to 95°F)

Humidity

Operating: 15% to 95% Relative Humidity (RH) (non-condensing)

Storage and Transport: 5% to 95% Relative Humidity (RH)

Altitude

Operating: -500m to 3000m (10000 ft.)

Storage and Transport: -500m to 4600m (15000 ft.)

Electrical and Safety Requirements (Customer or Philips)

Safety Requirements

If the MP2/X2 monitor is to be used in internal examinations on the heart or brain ensure that the monitor is connected to an equipotential grounding system.

Grounding

The monitor is an electrical Class II device in which the protection against electric shock does not rely on basic insulation and a protective earth conductor but on double and/or reinforced insulation.

WARNING

The functional earth conductor is required for EMC purposes. It has no protective function against electric shock! The protection against electric shock in this device is provided by double and/or reinforced insulation.

Do not use additional AC mains extension cords or multiple portable socket-outlets. If a multiple portable socket-outlet without an approved separating transformer is used, the interruption of its protective earthing may result in equipment leakage currents equal to the sum of the individual earth leakage currents, so exceeding allowable limits.

Electrical Requirements

Line Voltage Connection

The MP2/X2 external power supply uses < 50W (1.3 to 0.7 A).

Line Voltage

The MP2/X2 external power supply may be operated on ac line voltage ranges of 100 to 240V (50/60 Hz).

Connecting Non-Medical Devices

The standard IEC-60601-1-1 applies to any combination of medical and non-medical electrical devices, where at least one is a medical electrical device. Therefore IEC-60601-1-1 must still be met after all devices are connected.

For further details refer to the *Testing and Maintenance* section.

WARNING

Do not use a device in the patient vicinity if it does not comply with IEC-60601-1. The whole installation, including devices outside of the patient vicinity, must comply with IEC-60601-1-1; one reasonable solution may be the use of an isolation transformer. If the monitor is used with battery operation, always use an isolation transformer when connecting an additional display.

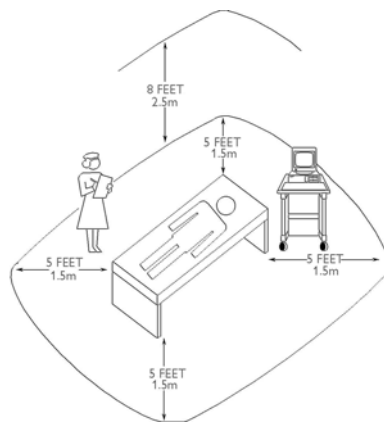

Equipment Location in the Patient Vicinity

NOTE

The site planning requirements, with the exception of the cabling, must be provided by the device manufacturer, if the remote device is not purchased from Philips.

Philips Medical LAN

For information refer to the IntelliVue Information Center documentation.

MP2/X2 Product Structure

The following tables show the product option structure for the MP2.

Standard Base Unit
User Interface
Touch
Multiple Profiles and Screen Layouts
Full Customization
Waves
3 Waves
Measurements
ECG/Resp
NBP
SpO2
Telemetry - Interface
Patient Data Management
Standard Database Size for Trends
Tabular and Graphical Trends
Screen Trends
Print ready Reports
Applications
Basic Arrhythmia
Full Arrhythmia
ST Segment Analysis, Trends and Snippets
EASI derived 12-lead ECG
QT/QTc
ST Map
12 Lead Display Application
Event Surveillance - single Event Group
Interfaces
Networking Hardware
Full Networking Software
ECG Sync Out
Add-Ons
One LiIon Battery

Mandatory Options		
Waves		
3 Waves		A03
4 Waves		A04
Application Areas		
General / Intensive Care Software		H10
Neonatal Software		H20
Anesthesia Software		H30
Cardiac Care Software		H40
SPO2 Options		
FAST		A01
Nellcor Oximax compatible		A02
Masimo SET technology		A03
Nellcor Oximax technology		A04
Interfaces		
LAN & Video output		J01
LAN & Battery Operation		J02
Advanced System Interface		J40
Measurements		
NBP		B02
SpO2, NBP		B10
SpO2, NBP, P, Temp		B11
SpO2, NBP, microstream CO2		B14
ECG, Resp, NBP, SpO2		B20
ECG, Resp, NBP, SpO2 +SureTemp		B21
ECG, Resp, NBP, SpO2 + IBP & Temp		B22
ECG, Resp, NBP, SpO2 + CO2		B23
ECG, Resp, NBP, SpO2 + microstream CO2		B24
ECG, Resp, NBP, SpO2 + TAAP +SureTemp		B31
ECG, Resp, NBP, SpO2 + TAAP + P/T		B32
ECG, Resp, NBP, SpO2, Press./Temp, SureTemp		B41
ECG, Resp, NBP, SpO2, Press./Temp x 2		B42
ECG, Resp, NBP, SpO2, Press./Temp, CO2 ready		B43
ECG, Resp, NBP, SpO2, P/T + microstream CO2		B44
ECG, Resp, NBP, SpO2, 2x P/T + microstream CO2		B54

Add-On Options		
Measurements		
IBP & Temp		C06
12 Lead ECG		C12
Add Respironics CO2 ready capability		C14
Conventional 12-lead and IBP&Temp		C18
Clinical Applications		
Full Arrhythmia Capability		C01
Neonatal Event Review		C04
Drug Calculator		C05
Basic Event Surveillance		C06
Time distribution bar graph (Histograms)		C09
Conventional 12 Lead ECG		C12
ST-Map		C13
Full Networking		C15
Protocol Watch		
Sepsis Screening		P01
XDS external display solution		
4-wave XDS connectivity		X04
6-wave XDS connectivity		X06
XDS remote control		X20
XDS clinical workstation		X30
Hardware Add-Ons		
Built-in recorder		E05
Roll Stand with Mounting plate		E17
Anti-slip pad		E18
Carrying Strap		E19
MMS Mount		E20
Bed hanger mount		E21
Quick release mount		E22
Protective cover		E23
Add 1 X Lithium-Ion battery		E24
Add 2 X Lithium-Ion battery		E26
Power and Network Adapter		E27
Handle		E31
Interfaces		
Companion mode		J21
IntelliVue 802.11 bedside adapter		J35
Instrument Telemetry 1.4GHz		J45
Short Range Radio		J46
Instrument Telemetry 2.4GHz		J47

System cables		
ECG Sync Signal Cable		SN3
SC1 SRL Connect Cable - 0.75 m		SC1
SC2 SRL Connect Cable - 2.0 m		SC2
SC4 SRL Connect Cable - 4.0 m		SC4
SC6 SRL Connect Cable - 10.0 m		SC6
SC7 SRL Connect Cable - 15.0 m		SC7
SC9 SRL Connect Cable - 25.0 m		SC9
Documents		
Provide paper documents		D01
Sensors and disposables		
Low cost 3&5 lead ECG bundles		
LCAcc.Bundle ICU-AAMI 3-ld		G06
LCAcc.Bundle ICU-IEC 3-ld		G07
LCAcc.Bundle ICU-AAMI 5-ld		G08
LCAcc.Bundle ICU-IEC 5-ld		G09
12-lead IntelliVue bundles		
H01 Accessory Bundle c12i ECG		H01
H02 Accessory Bundle c12i ECG		H02
H03 Accessory Bundle c12i ECG		H03
H04 Accessory Bundle c12i ECG		H04
5-lead IntelliVue bundles		
5 lead Accessories Bundle ICU-AAMI		H06
5 lead Accessories Bundle ICU-IEC		H07
5 lead Accessories Bundle OR-AAMI		H08
5 lead Accessories Bundle OR-IEC		H09
Neonatal IntelliVue bundles		
Accessories Bundle Neonatal -AAMI		H14
Accessories Bundle Neonatal -IEC		H15
3-lead IntelliVue bundles		
3 lead Accessories Bundle ICU-AAMI		H16
3 lead Accessories Bundle ICU-IEC		H17
3 lead Accessories Bundle OR-AAMI		H18
3 lead Accessories Bundle OR-IEC		H19
H20 Near Patient Application		H20
Mainstream CO2 accessories		
CO2 Mainstream Sensor		N01
Reusable Adult Airway Adaptor (msCO2)		N02
Reusable Infant Airway Adaptor (msCO2)		N03
Single use Adult Airway Adaptor (msCO2)		N04
Single use Infant Airway Adaptor (msCO2)		N05

Sidestream CO2 accessories		
CO2 Sidestream Sensor		N11
Non-intubated adult (ssCO2)		N12
Non-intubated pediatric (ssCO2)		N13
Intubated adult (ssCO2)		N14
Intubated infant (ssCO2)		N15
Microstream CO2 accessories		
Non-Intubated Adult		K30
Non-Intubated Pediatric		K31
Intubated Adult		K32
Intubated Infant/Neonatal		K33
Adult Non-Invas. Ventilat.		K34
Pedia. Non-Invas. Ventilat.		K35
Suretemp accessories		
Suretemp Oral with 25 probe covers		T01
Suretemp Rectal with 25 probe covers		T02

M8102A IntelliVue MP2 Product Structure

The following tables show the product option structure for the X2.

Standard Base Unit
User Interface
Touch
Multiple Profiles and Screen Layouts
Full Customization
Waves
3 Waves
Measurements
ECG/Resp
NBP
SpO2
Telemetry - Interface
Patient Data Management
Standard Database Size for Trends
Tabular and Graphical Trends
Screen Trends
Record/Print ready Reports
Cardiac Applications
Basic Arrhythmia
Full Arrhythmia
ST Segment Analysis, Trends and Snippets
EASI derived 12-lead ECG
QT/QTc
ST Map
12 Lead Display Application
Event Surveillance - single Event Group
Interfaces
Networking Hardware
Full Networking Software
ECG Sync Out (Sync pulse only)
Add-Ons
One LiIon Battery

Mandatory Options		
Waves		
3 Waves		A03
4 Waves		A04
Application Areas		
General / Intensive Care Software		H10
Neonatal Software		H20
Anesthesia Software		H30
Cardiac Care Software		H40
SPO2 Options		
FAST SPO2 Algorithm		A01
Nellcor Oximax compatible		A02
Masimo SPO2 Algorithm		A03
Nellcor Oximax SPO2 Algorithm		A04
Interfaces		
LAN & Video output		J01
LAN & Battery Operation		J02
Advanced System Interface		J40
Measurements		
NBP		B02
SpO2, NBP		B10
SpO2, NBP, P. Temp		B11
SpO2, NBP, microstream CO2		B14
ECG, Resp, NBP, SpO2		B20
ECG, Resp, NBP, SpO2 +SureTemp		B21
ECG, Resp, NBP, SpO2 + IBP & Temp		B22
ECG, Resp, NBP, SpO2 + CO2		B23
ECG, Resp, NBP, SpO2 + microstream CO2		B24
ECG, Resp, NBP, SpO2 + TAAP +SureTemp		B31
ECG, Resp, NBP, SpO2 + TAAP + P/T		B32
ECG, Resp, NBP, SpO2, Press./Temp, SureTemp		B41
ECG, Resp, NBP, SpO2, Press./Temp x 2		B42
ECG, Resp, NBP, SpO2, Press./Temp, CO2 ready		B43
ECG, Resp, NBP, SpO2, P/T + microstream CO2		B44
ECG, Resp, NBP, SpO2, 2x P/T + microstream CO2		B54

Add-On Options		
Measurements		
Add IBP & Temp		C06
12 Lead ECG		C12
Add Respiration CO2 ready capability		C14
Conventional 12-lead and IBP&Temp		C18
Clinical Applications		
Full Arrhythmia Capability		C01
Neonatal Event Review		C04
Drug Calculator		C05
Basic Event Surveillance		C06
Time distribution bar graph (Histograms)		C09
Conventional 12 Lead ECG		C12
ST-Map		C13
Full Networking		C15
Protocol Watch		
Sepsis Screening		P01
XDS external display solution		
4-wave XDS connectivity		X04
6-wave XDS connectivity		X06
XDS remote control		X20
XDS clinical workstation		X30
Hardware Add-Ons		
Built-in recorder		E05
Roll Stand with Mounting plate		E17
Anti-slip pad		E18
Carrying Strap		E19
MMS Mount		E20
Bed hanger mount		E21
Quick release mount		E22
Protective cover		E23
Add 1 X Lithium-Ion battery		E24
Add 2 X Lithium-Ion battery		E26
Power and Network Adapter		E27
Handle		E31
Interfaces		
Companion mode		J21
IntelliVue 802.11 bedside adapter		J35
1.4 G Smart Hopping		J45
Short Range Radio		J46
2.4 G Smart Hopping		J47

System cables		
ECG Sync Signal Cable		SN3
SC1 SRL Connect Cable - 0.75 m		SC1
SC2 SRL Connect Cable - 2.0 m		SC2
SC4 SRL Connect Cable - 4.0 m		SC4
SC6 SRL Connect Cable - 10.0 m		SC6
SC7 SRL Connect Cable - 15.0 m		SC7
SC9 SRL Connect Cable - 25.0 m		SC9
Documents		
Provide paper documents		D01

Sensors and disposables	
Low cost 3&5 lead ECG bundles	
LCAcc.Bundle ICU-AAMI 3-ld	G06
LCAcc.Bundle ICU-IEC 3-ld	G07
LCAcc.Bundle ICU-AAMI 5-ld	G08
LCAcc.Bundle ICU-IEC 5-ld	G09
12-lead IntelliVue bundles	
H01 Accessory Bundle c12i ECG	H01
H02 Accessory Bundle c12i ECG	H02
H03 Accessory Bundle c12i ECG	H03
H04 Accessory Bundle c12i ECG	H04
5-lead IntelliVue bundles	
5 lead Accessories Bundle ICU-AAMI	H06
5 lead Accessories Bundle ICU-IEC	H07
5 lead Accessories Bundle OR-AAMI	H08
5 lead Accessories Bundle OR-IEC	H09
Neonatal IntelliVue bundles	
Accessories Bundle Neonatal -AAMI	H14
Accessories Bundle Neonatal -IEC	H15
3-lead IntelliVue bundles	
3 lead Accessories Bundle ICU-AAMI	H16
3 lead Accessories Bundle ICU-IEC	H17
3 lead Accessories Bundle OR-AAMI	H18
3 lead Accessories Bundle OR-IEC	H19
H20 Near Patient Application	H20
Mainstream CO2 accessories	
CO2 Mainstream Sensor	N01
Reusable Adult Airway Adaptor (msCO2)	N02
Reusable Infant Airway Adaptor (msCO2)	N03
Single use Adult Airway Adaptor (msCO2)	N04
Single use Infant Airway Adaptor (msCO2)	N05
Sidestream CO2 accessories	
CO2 Sidestream Sensor	N11
Non-intubated adult (ssCO2)	N12
Non-intubated pediatric (ssCO2)	N13
Intubated adult (ssCO2)	N14
Intubated infant (ssCO2)	N15

Microstream CO2 accessories	
Non-Intubated Adult	K30
Non-Intubated Pediatric	K31
Intubated Adult	K32
Intubated Infant/Neonatal	K33
Adult Non-Invas. Ventilat.	K34
Pedia. Non-Invas.Ventilat.	K35
Suretemp accessories	
Suretemp Oral with 25 probe covers	T01
Suretemp Rectal with 25 probe covers	T02

M3002A IntelliVue X2 Product Structure

Upgrades

The following table shows the upgrade options for the X2.

Mandatory Options		
Waves		
	3 Waves	A03
	4 Waves	A04
Application Areas		
	General / Intensive Care Software	H10
	Neonatal Software	H20
	Anesthesia Software	H30
	Cardiac Care Software	H40
SPO2 Options		
	FAST	A01
	Nellcor Oximax compatible	A02
	Masimo SET technology	A03
	Nellcor Oximax technology	A04
Interfaces		
	LAN & Video output	J01
	LAN & Battery Operation	J02
	Advanced System Interface	J40
Measurements		
	NBP	B02
	SpO2, NBP	B10
	SpO2, NBP, P. Temp	B11
	SpO2, NBP, microstream CO2	B14
	ECG, Resp, NBP, SpO2	B20
	ECG, Resp, NBP, SpO2 +SureTemp	B21
	ECG, Resp, NBP, SpO2 + IBP & Temp	B22
	ECG, Resp, NBP, SpO2 + CO2	B23
	ECG, Resp, NBP, SpO2 + microstream CO2	B24
	ECG, Resp, NBP, SpO2 + TAAP +SureTemp	B31
	ECG, Resp, NBP, SpO2 + TAAP + P/T	B32
	ECG, Resp, NBP, SpO2, Press./Temp, SureTemp	B41
	ECG, Resp, NBP, SpO2, Press./Temp x 2	B42
	ECG, Resp, NBP, SpO2, Press./Temp, CO2 ready	B43
	ECG, Resp, NBP, SpO2, P/T + microstream CO2	B44
	ECG, Resp, NBP, SpO2, 2x P/T + microstream CO2	B54

Add-On Options		
Measurements		
	IBP & Temp	C06
	12 Lead ECG	C12
	Add Respironics CO2 ready capability	C14
	Conventional 12-lead and IBP&Temp	C18
Clinical Applications		
	Full Arrhythmia Capability	C01
	Neonatal Event Review	C04
	Drug Calculator	C05
	Basic Event Surveillance	C06
	Time distribution bar graph (Histograms)	C09
	Conventional 12 Lead ECG	C12
	ST-Map	C13
	Full Networking	C15
Protocol Watch		
	Sepsis Screening	P01
	Sepsios Screening + SW	P41
XDS external display solution		
	4-wave XDS connectivity	X04
	6-wave XDS connectivity	X06
	XDS remote control	X20
	XDS clinical workstation	X30
Hardware Add-Ons		
	Built-in recorder	E05
	Roll Stand with Mounting plate	E17
	Anti-slip pad	E18
	Carrying Strap	E19
	MMS Mount	E20
	Bed hanger mount	E21
	Quick release mount	E22
	Protective cover	E23
	Add 1 X Lithium-Ion battery	E24
	Add 2 X Lithium-Ion battery	E26
	Power and Network Adapter	E27
	Handle	E31

Interfaces		
	MSL Interface	J21
	IntelliVue 802.11 bedside adapter	J35
	1.4 G Smart Hopping	J45
	Short Range Radio	J46
	2.4 G Smart Hopping	J47
Documents		
	Provide paper documents	D01
Software upgrade		
	Latest IntelliVue SW	SU0

M3002AU IntelliVue X2 Upgrades

Default Settings Appendix

This appendix documents the country-specific default settings of your monitor as it is delivered from the factory. For a comprehensive list and explanation of default settings, see the Configuration Guide supplied with your monitor. The monitor's default settings can be permanently changed in Configuration Mode.

Note: If your monitor has been ordered preconfigured to your requirements, the settings at delivery will be different from those listed here.

Country-Specific Default Settings

Certain default settings are specific to a particular country. These are listed here for all countries alphabetically.

Country-Description	Line Frequency	Units Weight	Units Height	ECG Cable Color
	50/60 [Hz]	kg, lb	in, cm	IEC, AAMI
Afghanistan	50	kg	cm	AAMI
Åland Islands	50	kg	cm	IEC
Albania	50	kg	cm	IEC
Algeria	50	kg	cm	IEC
American Samoa	60	lb	in	AAMI
Andorra	60	lb	in	AAMI
Angola	50	kg	cm	IEC
Anguilla	60	lb	in	AAMI
Antarctica	60	lb	in	AAMI
Antigua and Barbuda	50	kg	cm	AAMI
Argentina	50	kg	cm	AAMI
Armenia	50	kg	cm	IEC
Aruba	60	kg	cm	AAMI

Country-Description	Line Frequency	Units Weight	Units Height	ECG Cable Color
Australia	50	kg	cm	AAMI
Austria	50	kg	cm	IEC
Azerbaijan	50	kg	cm	IEC
Bahamas, The	60	kg	cm	AAMI
Bahrain	50	kg	cm	AAMI
Bangladesh	60	lb	in	AAMI
Barbados	50	kg	cm	AAMI
Belarus	50	kg	cm	IEC
Belgium	50	kg	cm	IEC
Belize	60	lb	in	AAMI
Benin	60	lb	in	AAMI
Bermuda	60	kg	cm	AAMI
Bhutan	60	lb	in	AAMI
Bolivia	50	kg	cm	AAMI
Bosnia and Herzegovina	50	kg	cm	IEC
Botswana	50	kg	cm	IEC
Bouvet Island	60	lb	in	AAMI
Brazil	60	kg	cm	AAMI
British Indian Ocean Territory	60	lb	in	AAMI
Brunei Darussalam	50	kg	cm	AAMI
Brunei	50	kg	cm	IEC
Bulgaria	50	kg	cm	IEC
Burkina Faso	50	kg	cm	IEC
Burundi	50	kg	cm	IEC
Cambodia	50	kg	cm	IEC
Cameroon	50	kg	cm	IEC
Canada	60	kg	cm	AAMI
Cape Verde	60	lb	in	AAMI
Cayman Islands	60	kg	cm	AAMI
Central African Republic	50	kg	cm	IEC
Chad	60	lb	in	AAMI
Chile	50	kg	cm	AAMI

Country-Description	Line Frequency	Units Weight	Units Height	ECG Cable Color
China	50	kg	cm	IEC
Christmas Islands	60	lb	in	AAMI
Cocos Keeling Islands	60	lb	in	AAMI
Colombia	60	kg	cm	AAMI
Comoros	60	lb	in	AAMI
Congo	50	kg	cm	IEC
Congo, Democratic Republic of the	50	kg	cm	IEC
Cook Islands	60	lb	in	AAMI
Costa Rica	60	kg	cm	AAMI
Côte d'Ivoire	50	kg	cm	IEC
Croatia	50	kg	cm	IEC
Cuba	60	kg	cm	IEC
Cyprus	50	kg	cm	IEC
Czech Republic	50	kg	cm	IEC
Denmark	60	lb	in	AAMI
Djibouti	50	kg	cm	IEC
Dominica	50	kg	cm	AAMI
Dominican Republic	60	kg	cm	AAMI
Ecuador	60	kg	cm	AAMI
Egypt	50	kg	cm	IEC
El Salvador	60	kg	cm	AAMI
Equatorial Guinea	50	kg	cm	IEC
Eritrea	50	kg	cm	IEC
Estonia	50	kg	cm	IEC
Ethiopia	50	kg	cm	IEC
Falkland Islands, Malvinas	60	lb	in	AAMI
Faroe Islands	60	lb	in	AAMI
Fiji	60	lb	in	AAMI
Finland	50	kg	cm	IEC
France	50	kg	cm	IEC
French Guiana	50	kg	cm	IEC
French Polynesia	60	lb	in	AAMI

Country-Description	Line Frequency	Units Weight	Units Height	ECG Cable Color
French Southern Territories	60	lb	in	AAMI
Gabon	50	kg	cm	IEC
Gambia, The	50	kg	cm	IEC
Georgia	60	lb	in	AAMI
Germany	50	kg	cm	IEC
Ghana	50	kg	cm	IEC
Gibraltar	60	lb	in	AAMI
Greece	50	kg	cm	IEC
Greenland	60	lb	in	AAMI
Grenada	50	kg	cm	AAMI
Guadeloupe	50	kg	cm	IEC
Guam	60	lb	in	AAMI
Guatemala	60	kg	cm	AAMI
Guernsey	50	kg	cm	IEC
Guinea	60	lb	in	AAMI
Guinea-Bissau	60	lb	in	AAMI
Guyana	60	kg	cm	AAMI
Haiti	60	kg	cm	AAMI
Heard Island and McDonald Islands	60	lb	in	AAMI
Holy See, Vatican City State	60	lb	in	AAMI
Honduras	60	kg	cm	AAMI
Hong Kong	50	kg	cm	IEC
Hungary	50	kg	cm	IEC
Iceland	50	kg	cm	IEC
India	50	kg	cm	IEC
Indonesia	50	kg	cm	IEC
Iran, Islamic Republic of	50	kg	cm	AAMI
Iraq	50	kg	cm	AAMI
Ireland	50	kg	cm	IEC
Isle of Man	50	kg	cm	IEC
Israel	50	kg	cm	IEC
Italy	50	kg	cm	IEC

Country-Description	Line Frequency	Units Weight	Units Height	ECG Cable Color
Jamaica	50	kg	cm	AAMI
Japan	60	kg	cm	IEC
Jersey	50	kg	cm	IEC
Jordan	50	kg	cm	AAMI
Kazakhstan	50	kg	cm	IEC
Kenya	50	kg	cm	IEC
Kiribati	60	lb	in	AAMI
Korea, Democratic People's Republic of	60	lb	in	AAMI
Korea, Republic of	60	kg	cm	AAMI
Kuweit	50	kg	cm	AAMI
Kyrgyzstan	60	lb	in	AAMI
Lao People's Democratic Republics	50	kg	cm	IEC
Latvia	50	kg	cm	IEC
Lebanon	50	kg	cm	AAMI
Lesotho	50	kg	cm	IEC
Liberia	50	kg	cm	IEC
Libyan Arab. Jamahiriya	60	lb	in	AAMI
Liechtenstein	60	lb	in	AAMI
Lithuania	50	kg	cm	IEC
Luxembourg	50	kg	cm	IEC
Macao	60	lb	in	AAMI
Macedonia, The former Yugoslav. Rep. of	50	kg	cm	IEC
Madagascar	50	kg	cm	IEC
Malawi	50	kg	cm	IEC
Malaysia	50	kg	cm	IEC
Maldives	60	lb	in	AAMI
Mali	50	kg	cm	IEC
Malta	50	kg	cm	IEC
Marshall Islands	60	lb	in	AAMI
Martinique	60	kg	cm	IEC
Mauritania	50	kg	cm	IEC
Mauritius	60	lb	in	AAMI

Country-Description	Line Frequency	Units Weight	Units Height	ECG Cable Color
Mayotte	60	lb	in	AAMI
Mexico	60	kg	cm	AAMI
Micronesia, Fed. States of	60	lb	in	AAMI
Moldova, Republic of	60	lb	in	AAMI
Monaco	60	lb	in	AAMI
Mongolia	60	lb	in	AAMI
Montenegro	50	kg	cm	IEC
Montserrat	50	kg	cm	AAMI
Morocco	50	kg	cm	IEC
Mozambique	50	kg	cm	IEC
Myanmar	60	lb	in	AAMI
Namibia	50	kg	cm	IEC
Nauru	60	lb	in	AAMI
Nepal	60	lb	in	AAMI
Netherlands	50	kg	cm	IEC
Netherlands Antilles	50	kg	cm	AAMI
New Caledonia	60	lb	in	AAMI
New Zealand	50	kg	cm	AAMI
Nicaragua	60	kg	in	AAMI
Niger	50	kg	cm	IEC
Nigeria	50	kg	cm	IEC
Niue	60	lb	in	AAMI
Norfolk Islands	60	lb	in	AAMI
Northern Mariana Islands	60	lb	in	AAMI
Norway	50	kg	cm	IEC
Oman	50	kg	cm	AAMI
Pakistan	50	kg	cm	IEC
Palau	60	lb	in	AAMI
Palestinian Territory	50	kg	cm	AAMI
Panama	60	lb	in	AAMI
Papua New Guinea	60	lb	in	AAMI
Paraguay	50	kg	cm	AAMI

Country-Description	Line Frequency	Units Weight	Units Height	ECG Cable Color
Peru	60	kg	cm	AAMI
Philippines	60	kg	cm	AAMI
Pitcairn	60	lb	in	AAMI
Poland	50	kg	cm	IEC
Portugal	50	kg	cm	IEC
Puerto Rico	60	lb	in	AAMI
Qatar	50	kg	cm	AAMI
Reunion	60	lb	in	AAMI
Romania	50	kg	cm	IEC
Russian Federation	50	kg	cm	IEC
Rwanda	50	kg	cm	IEC
Saint Helena	60	lb	in	AAMI
Saint Kitts and Nevis	60	kg	cm	AAMI
Saint Lucia	50	kg	cm	AAMI
Saint Pierre and Miquelon	60	lb	in	AAMI
Saint Vincent and the Grenadines	50	kg	cm	AAMI
Samoa	60	lb	in	AAMI
San Marino	60	lb	in	AAMI
Sao Tome and Principe	60	lb	in	AAMI
Saudi Arabia	50	kg	cm	AAMI
Senegal	50	kg	cm	IEC
Serbia	50	kg	cm	IEC
Serbia & Montenegro	50	kg	cm	IEC
Seychelles	60	lb	in	AAMI
Sierra Leone	50	kg	cm	IEC
Singapore	50	kg	cm	IEC
Slovakia	50	kg	cm	IEC
Slovenia	50	kg	cm	IEC
Solomon Islands	60	lb	in	AAMI
Somalia	50	kg	cm	IEC
South Africa	60	lb	in	AAMI
South Georgia and the South Sandwich Islands	60	lb	in	AAMI

Country-Description	Line Frequency	Units Weight	Units Height	ECG Cable Color
Spain	50	kg	cm	IEC
Sri Lanka	60	lb	in	AAMI
Sudan	50	kg	cm	IEC
Suriname	60	kg	cm	AAMI
Svalbard and Jan Mayen	60	lb	in	AAMI
Swaziland	60	lb	in	AAMI
Sweden	50	kg	cm	IEC
Switzerland	50	kg	cm	IEC
Syrian Arab Rep	50	kg	cm	AAMI
Taiwan, Province of China	60	kg	cm	AAMI
Tajikistan	60	lb	in	AAMI
Tanzania, United Republic of	60	lb	in	AAMI
Thailand	50	kg	cm	AAMI
Timor-Leste	60	lb	in	AAMI
Togo	60	lb	in	AAMI
Tokelau	60	lb	in	AAMI
Tonga	60	lb	in	AAMI
Trinidad and Tobago	60	lb	in	AAMI
Tunisia	50	kg	cm	IEC
Turkey	50	kg	cm	IEC
Turkmenistan	60	lb	in	AAMI
Turks and Caicos Islands	60	kg	cm	AAMI
Tuvalu	60	lb	in	AAMI
Uganda	60	lb	in	AAMI
Ukraine	60	lb	in	AAMI
UK	50	kg	cm	IEC
United Arab Emirates	50	kg	cm	AAMI
United Kingdom	50	kg	cm	OIEC
United States	60	lb	in	AAMI
United States (Weight kg)	60	kg	in	AAMI
United States (Height cm, Weight kg)	60	kg	cm	AAMI
United States Minor Outlying Islands	60	lb	in	AAMI

Country-Description	Line Frequency	Units Weight	Units Height	ECG Cable Color
Uruguay	50	kg	cm	AAMI
Uzbekistan	60	lb	in	AAMI
Vanuatu	60	lb	in	AAMI
Venezuela	60	lb	in	AAMI
Viet Nam	50	kg	cm	IEC
Virgin Islands (British)	50	kg	cm	AAMI
Virgin Islands (US)	60	lb	in	AAMI
Wallis and Futuna Islands	60	lb	in	AAMI
Western Sahara	50	kg	cm	IEC
Yemen	50	kg	cm	AAMI
Zambia	60	lb	in	AAMI
Zimbabwe	60	lb	in	AAMI

Index

A

- About the Battery • 101
- adjustments • 10
- After Each Service, Maintenance or Repair Event • 36
- After Installation, Testing or Repair • 111
- Alarm Behavior • 131
- Alarm Lamps • 130
- Alarm Tones • 130
- Altitude • 229
- Assembling the dual Link Bar • 176
- assembly • 10

B

- Barometric Pressure Check and Calibration • 90
- Basic Performance Assurance Test • 79
- battery
 - and display brightness • 107
 - charge status • 106
 - conserving power • 107
 - malfunction symbols • 103
 - power gauge • 103
 - replacing • 106
 - safety information • 111
- Battery Conditioning in the Monitor • 109
- Battery Conditioning with an External Charger • 110
- Battery Handling, Maintenance and Good Practices • 101
- battery performance
 - optimizing • 107
- Battery related problems • 123
- Battery Safety Information • 111
- Battery Status
 - checking • 102
- Battery Status on the Main Screen • 103

battery status recording • 106
battery status window • 104
Battery Status Window • 104
Bedside Network Status Icons • 119, 125
Before Each Use • 35, 36
Block Diagram Legend • 24
Boot Phase Failures • 119

C

Calibration Verification • 92
Cardiac Output Performance Test • 93
Carrying Out and Reporting Tests • 98
Case 1
 Medical Device Combined with Medical Device • 69
Case 2
 Medical Device Combined with a Non-Medical Device • 71
Case 3
 Medical Device Combined with a Medical or Non-Medical Device with one Device in a Non-Medically-Used Room • 75
Charging a Battery • 108
Check for Obvious Problems • 116
checking battery charge • 106
Checking Battery Charge • 106
Checking Country-Specific Default Settings • 212
Checking Out the Monitor • 211
Checking the Battery Status • 102
checklist
 delivery • 202
 installation • 201
Checks before opening the instrument • 116
Checks Before Opening the Instrument • 116
Checks for Obvious Problems • 116
Checks with the Instrument switched Off • 116
Checks with the Instrument switched On, external AC power connected, with battery • 116
Checks with the Instrument switched On, external AC power not connected, with battery • 117
Claims for Damage • 202
cleaning
 recommended substances • 137
Cleaning the Air Filter Mats • 184
CO2
 Calibration Verification • 92
 Flow Rate Check and Calibration • 90
 Noise Check • 91
 Pump check • 90

- CO2 Gas Measurement Calibration Check • 91
- CO2 Pump / CO2 Scrubber Replacement • 93
- Companion Mode Problems • 119, 133
- Compatibility with Information Center • 115
- Compatibilty with MMS • 114
- Compatible Devices • 19
- Conditioning a Battery • 108
- Conditioning Batteries • 109
- configuration mode
 - entering • 212
- Configuration Settings for CSCN Routed Bedside Monitors (RBM) • 214
- Configuration Tasks • 212
- Configuring IP Address, Subnet Mask and Default Gateway • 214
- Configuring Routed Bedside Monitors Support • 215
- Configuring SRR Channels • 218
- Configuring the Equipment Label • 213
- Connecting Non-Medical Devices • 230
- connecting power • 210
- Connecting the Monitor to AC Mains • 209
- Country-Specific Default Settings • 239

D

- damage claims • 202
- Data Acquisition • 20
- Data Flow • 20
- Data Provider System Service • 21
- date, setting • 215
- default settings • 239
- Default Settings Appendix • 239
- Disassembly Procedures for the M3015A MMS Extension (HW Rev. A) • 178
- Display and User Interface Service • 21
- display brightness • 107
- Display Brightness Setting • 107
- Display is blank • 119, 121

E

- ECG Performance • 80
- ECG Sync Performance Test • 81
- ECG Sync Pulse • 221
- ECG/Resp
 - Performance check • 80
- ECG/Resp Performance Test • 80
- Electrical and Safety Requirements (Customer or Philips) • 229
- Electrical Requirements • 229

Electromagnetic Interference (SRR) • 201
Environmental Requirements • 228
Evaluation of Test Results • 35, 100
Exchange and Replacement Parts • 189
Exchange Parts
 listing • 195
Exchange Parts List • 195
Exchange Procedures • 167
Exchanging the Loudspeaker • 153
Exchanging the Main Housing • 163
Exchanging the NBP Airguide / IIT or WLAN Assembly • 148
Exchanging the NBP Pump • 146
Exchanging the Silicon Pads • 165
extensions • 10
External Power Supply M8023A(Standard with MP2, Optional with X2) • 210

F

Final Inspection • 177
Flow Rate Check and Calibration • 90
Following Reassembly • 183
Full Performance Assurance Test • 80

G

General Monitor INOP Messages • 119, 123
General Reassembly/Refitting Comments • 183
General Requirements for a System • 65
Guideline for Performance of Safety Tests • 40

H

Handing Over the Monitor • 216
Hardware Building Blocks • 16
Hints for Correct Performance of Safety Tests • 40
Host Monitor as Power Source • 209
How does the Support Tool Work with the Monitor • 23
How to use the Troubleshooting tables • 119
How to Use This Guide • 9
How To Use This Section • 113
Humidity • 229

I

IIT Communication Test • 96
IIT-related Problems • 119, 127
Image Sticking • 133
Individual Parameter INOPs • 119, 131

- Initial Inspection • 202
- Initial Instrument Boot Phase • 117
- installation • 10, 199
 - checklist • 201
 - personnel • 199
- Installation Checklist • 201
- Installation Instructions • 199
- IntelliVue 802.11 Bedside Adapter Communication Test • 95
- IntelliVue 802.11 Bedside Adapter Problems • 126
- IntelliVue Instrument Telemetry (IIT) • 217
- IntelliVue MP2 • 16
- IntelliVue X2 • 17
- Internal LAN (Measurement Link) • 22
- Introduction • 9, 29, 113, 225
- Invasive Pressure Performance Test • 84
- Isolating problems to the correct subassembly • 113, 137

L

- Leakage Check • 89
- List of Error Codes • 134
- Locking/Unlocking Touch Operation • 101

M

- M3014A Capnography Extension Performance Tests • 85
- mains power
 - connecting to • 209
- Mainstream CO2 Accuracy Check • 85
- malfunction symbols
 - battery • 103
- Measurement Validation • 82
- Microstream CO2 Performance Test • 88
- MMS Extension Part Numbers - Front Bezels • 193
- MMS Extension Part Numbers - Release Mechanisms • 192
- MMS Extension Part Numbers - Top Cover, Flex Cable and Link Bar • 193
- MMS Extension Parts (M3012A, M3014A, M3015A and M3016A) • 192
- MMS Extensions - Exchanging the Top Cover, MSL Flex Cable and the Dual Link Bar • 167
- modifications • 10
- Monitor Applications • 21
- monitor defaults • 239
- Monitor Site Requirements • 228
- Monitor Software Block Diagram • 23
- Monitor Theory of Operation • 13
- Mounting the MMS Mount to the FMS (M8048A) • 208
- Mounting the Monitor • 203

Mounting the Monitor onto the Rollerstand • 208
Mounting the Monitor using the Anti-slip Pad • 203
Mounting the Monitor using the MMS Mount and Mounting Clamp • 205
MP2/X2 Product Structure • 232
MSL Cable Termination • 222

N

NBP Accuracy Test • 82
NBP Leakage Test • 83
NBP Linearity Test • 84
NBP Performance Test • 82
Network related problems • 125
Noise Check • 91
Noninvasive Blood Pressure Measurement Calibration • 79
Nurse Call Relay
 Performance Test • 93

O

Obtaining Replacement Parts • 115
Optimizing Battery Performance • 107
Optional Hardware • 17
Other Regular Tests • 101
Out-Of-Hospital Transport - Standards Compliance • 199

P

Parts • 187
parts and accessories • 10
Passwords • 10
PCB
 replacement level support • 114
performance • 10
Performance Assurance Tests • 35, 79
Persistent Data Storage System Service • 21
Philips Clinical Network • 22
Philips Clinical Network (Wired) • 216
Philips IntelliVue Information Center • 216
Philips Medical LAN • 230
power
 connecting • 210
 connection • 209
Power Distribution • 17
Power Loss Alarm Buzzer Performance Test (only if Multi-Port Nurse Call Connector Board is installed) • 95
Power On Test • 36
Preventive Maintenance Procedures • 79

- Printer • 131
- Printing Battery Status • 106
- Procedures for Local Staff • 226
- Procedures for Philips Personnel • 228
- Pump Check • 90

R

- Reassembling the NBP pump chassis • 144
- Reassembly of the Display • 141
- Reassembly Procedure • 150, 154, 157
- Recommended Frequency • 30
- recording
 - battery status • 106
- Refit Procedures for the MMS Extension • 182
- Refitting the CO2 Scrubber • 182
- Refitting the Extension Bottom Cover • 183
- Refitting the Front Cover • 177, 183
- Refitting the Pump • 182
- Refitting the Top Cover • 175
- reliability • 10
- Removing the Battery • 138
- Removing the CO2 Scrubber • 180
- Removing the Display/Exchanging the SRR Board • 139
- Removing the Dual Link Bar • 169
- Removing the ECG Sync Pulse Out Connector • 158
- Removing the Extension Bottom Cover • 179
- Removing the Front Cover • 168, 178
- Removing the Handle • 138
- Removing the Main Board • 159
- Removing the Measurements • 162
- Removing the Mounting Pin • 168
- Removing the NBP Pump Assembly • 142
- Removing the Power Board • 155
- Removing the Pump • 181
- Removing the Rear Housing • 161
- Removing the Side Cover • 139
- Removing the Top Cover • 172
- Repacking • 202
- Repair and Disassembly • 137
- repairs • 10
 - qualified personnel • 113
- Replacement level
 - major subassembly • 114

PCB • 114
Replacement Level Supported • 114
Replacement parts. See Spare parts • 115
Replacing a Battery • 106
replacing batteries • 106
Replacing the Fan • 184
Replacing the Flex Cable Assembly • 172
Reporting of Test Results • 35, 98
Required Protective Measures at System Installation • 68
Reset Time Counters • 93
Respiration Performance • 80
Responsibility of the Manufacturer • 10
Roles & Responsibilities • 226

S

S(1)
 Detachable Power Cord Protective Earth Test (optional) • 60
S(2)
 Equipment Leakage Current Test - Normal Condition (optional) • 61
S(3)
 Equipment Leakage Current Test - Single Fault Condition (optional) • 62
S(4)
 Applied Part Leakage Current - Mains on Applied Part • 63
safety • 10
safety information
 batteries • 111
Safety Requirements • 229
Safety Test Adapter Cable - Schematics • 42
Safety Test Procedures • 35, 39
Safety Tests • 37
 performance tests • 211
 power on test • 211
 system • 211
 visual inspection • 211
Service Tool Procedure, Version 1 • 94
Service Tool Procedure, Version 2 • 94
Setting Altitude, Line Frequency, ECG Cable Colors and Height & Weight Units • 213
Setting the Date and Time • 215
settings
 default • 239
Short Range Radio • 218
Short Range Radio (SRR) Performance Test • 97
Short Range Radio Interface Problems • 128

- Sidestream CO2 Accuracy Check • 86
- Sidestream CO2 Flow Check • 87
- Sidestream CO2 Performance Test • 88
- Site Planning • 225
- Site Preparation • 225
- Site Preparation Responsibilities • 226
- Smart Battery Charger LG1480 (M8043A) • 184
- Smart Battery Charger Part Numbers • 197
- Software Compatibility Matrix • 114
- Software Revision Check • 114
- Space Requirements • 228
- Spare parts
 - obtaining • 114
- SpO2 Performance Test • 81
- SRR Channel Settings Configuration Implications • 219
- Status Log • 133
- Storing a Battery • 110
- symbols
 - battery • 103
- System Boundaries • 14
- System Example • 65
- System Installation Requirements • 67
- System Interfaces • 18
- System Test • 37, 64
- System Test Procedure • 78

T

- Telemetry Device related Problems (TAAP) • 127
- Temperature • 228
- Temperature Performance Test • 85
- Terminology and Definitions • 30
- test blocks, how to perform • 211
- Testing • 178
- Testing and Maintenance • 29
- Testing Sequence • 35
- Theory of Operation • 13
- Time counters
 - resetting • 93
- time, setting • 215
- Tools required • 137
- Touch Operation not functioning • 119, 122
- transport brightness setting • 107
- Troubleshooting • 113

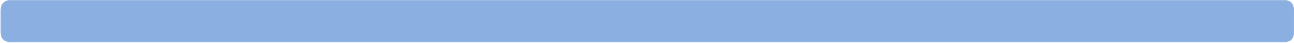

Troubleshooting Guide • 115
Troubleshooting Tables • 118
Troubleshooting the ECG Sync Pulse • 119, 132
Troubleshooting the Individual Measurements or Applications • 135
Troubleshooting with the Support Tool • 135

U

unpacking • 201
Unpacking and Checking the Shipment • 201
Upgrades • 236

V

Valve Test • 84
Viewing Battery Details • 106
Visual Inspection • 36
voltage setting • 210

W

Warnings and Cautions • 11
Warnings, Cautions, and Safety Precautions • 38
What Causes the Conditioning Message on the Monitor? • 109
What is a Medical Electrical System? • 65
What is Battery Conditioning? • 108
When Should Battery Conditioning be Performed? • 108
When to Perform Tests • 31
Who Should Perform Repairs • 113, 137
Who Should Use This Guide • 9
Why is Battery Conditioning Necessary? • 108
window
 battery status • 104