

Operating Instructions

G 7782 CD Washer/Disinfector

To prevent accidents
and machine damage,
read these instructions

before
installation or use.





Read all instructions before using the washer disinfectant. This equipment is suitable for the applications mentioned in the operating instructions. Do not use for purposes other than those for which it was designed, as these may be dangerous. The manufacturer cannot be held responsible for damage caused by improper use.

Contents

WARNINGS AND SAFETY INSTRUCTIONS	5
Indications for use	9
Guide to the disinfectant	10
Opening and closing the door	12
Instrument Guidelines	13
Instruments suitable for processing in the Washer/Disinfectant	13
Instruments not suitable for processing in the Washer/Disinfectant	13
Cleaning Without Disinfection	13
Loading the washer/disinfectant	14
Loading accessory baskets/inserts	14
Loading the washer/disinfectant	15
Adjustable upper basket	15
Loading examples	16
MIS injector mobile unit E 450	20
Loading instructions	20
Loading examples	21
Adding detergent	24
Adding neutralizing rinse	26
Cycle selection	28
WARNINGS AND SAFETY INSTRUCTIONS	Center pages
Washer/Disinfectant operation	34
Cycle Operation	34
Cycle phase indicators	35
Selecting an additional cycle	35
Interrupting a cycle	36
Unloading the washer/disinfectant	37
Programming special functions	38
Cleaning and care	39
Maintaining the filter assembly	39
Maintaining the dispensing system	41
Maintaining the drying unit	42
Reactivating the water softener	44
Troubleshooting	46
Installation instructions	49

WARNINGS AND SAFETY INSTRUCTIONS

The following is a summary of the safety precautions which must be observed when operating and servicing this equipment. These precautions are repeated (in whole or in part), where applicable throughout the manual.

All relevant safety procedures must be obeyed. Relevant safety procedures include, but are not limited to, the Centers for Disease Control's Recommended Infection Control Practices and the OSHA Bloodborne Pathogens Standard.

READ ALL INSTRUCTIONS BEFORE USING THE APPLIANCE

WARNING -

The manufacturer cannot accept responsibility for damage caused when the appliance is not used according to the instructions, or for uses other than those for which it was intended.

The manufacturer cannot be held responsible for problems or injuries resulting from improper installation, use or operation of this equipment.

WARNINGS AND SAFETY INSTRUCTIONS

■ **WARNING - PERSONAL INJURY HAZARD:** Do not allow small children or unauthorized personnel access to the washer/disinfector or its controls.

■ **WARNING - EXPLOSION HAZARD:** Do not install the washer/disinfector in areas where flammable compounds/vapors are present.

■ **WARNING - PERSONAL INJURY/EQUIPMENT DAMAGE HAZARD:** Repair work must be carried out only by a qualified and competent service technician. Repairs by unqualified persons or installation of unauthorized parts could cause personal injury, result in costly equipment damage or void the washer/disinfector warranty.

■ **WARNING - BURN HAZARD:** Except for an emergency, do not open door when cycle is in process. In an emergency, first stop the cycle by pressing the ON/OFF button. Press the DRAIN touch pad and wait for washer/disinfector to drain. Wear protective gloves and face shield whenever reaching into wash cabinet.

■ **WARNING - ELECTRICAL SHOCK HAZARD:** Disconnect all utilities to equipment before servicing. Do not service equipment unless all utilities have been properly locked out.

■ **WARNING - PERSONAL INJURY/EQUIPMENT DAMAGE HAZARD:** Only use detergents which have been approved by Miele. Use of any other products may cause personal injury, invalidate the disinfection results or void the washer/disinfector warranty.

■ **WARNING - PERSONAL INJURY HAZARD:** The water in this washer/disinfector is not suitable for drinking.

■ **WARNING - PERSONAL INJURY HAZARD:** Be careful when sorting instruments with sharp pointed ends. If possible, place the pointed end downwards.

■ **WARNING - CHEMICAL BURN HAZARD:** Wear protective gloves and goggles and use care when handling liquids such as detergents or neutralizing agents. Read and follow the instructions and safety procedures on the packaging and in the **M**aterial **S**afety **D**ata **S**heet (MSDS).

WARNINGS AND SAFETY INSTRUCTIONS

■ **WARNING - PERSONAL INJURY/
EQUIPMENT DAMAGE HAZARD:**
Empty containers and glassware before placing in the washer/disinfector. Do not allow any acids or solvents, especially hydrochloric acid and chlorides, to get into the wash cabinet.

■ **WARNING - PERSONAL INJURY/
EQUIPMENT DAMAGE HAZARD:**
Internal cleaning and disinfecting to a measurable standard can only be achieved with instruments that can be dismantled and where the jets, sleeves and adapters are used appropriately. A special examination, over and above a visual one, of the cleanliness of the inner area of the instruments should be made. Minimally invasive surgical (MIS) and dental instruments should preferably be processed using the DISIN VARIO 93°C-10 MIN or DISIN 93°C-10 MIN program with recommended detergents.

■ **WARNING - BURN HAZARD:** Allow accessories to cool to room temperature before unloading. Any water which may have collected in incorrectly loaded items will be very hot and should be emptied into the wash cabinet.

■ **WARNING - BURN HAZARD:**
Do not touch the heating elements in wash cabinet after the end of a cycle.

■ **WARNING - TIPPING HAZARD:** Do not sit or lean on the open door. This could cause the washer/disinfector to tip.

■ **WARNING - FALL HAZARD:**
To prevent falls, keep floors dry by immediately wiping up any spilled liquids in washer/disinfector loading and unloading areas.

■ **WARNING - ELECTRIC SHOCK
HAZARD:** Washer/disinfector must be correctly grounded!

■ **WARNING - POTENTIAL
BIOHAZARD:** Always use DISINFECTION cycles when processing dental or medical instruments and accessories. Only DISINFECTION cycles provide high levels of disinfection.

■ **WARNING - PERSONAL INJURY/
EQUIPMENT DAMAGE HAZARD:**
Do not fill the white cylindrical container with cleaning detergent! Fill with reactivation salt only! Otherwise the pressurized container may cause injuries by unscrewing.

WARNINGS AND SAFETY INSTRUCTIONS

■ If thermal disinfection is required (93 °C / 10 min.), the process needs to be checked and documented regularly. This can be done by checking the disinfection control diode on the machine. Alternatively, a chemical indicator may be used (e.g. the Disinfection Control Tubes by A. Browen Ltd., supplied by Miele). These disinfection control tubes should be placed in the filter combination. After the disinfection cycle, they may be inspected by removing the coarse filter.

■ CAUTION: Washer/disinfector must not be used without all filters in place.

■ CAUTION: Use only accessories specifically designed for this equipment. Load accessories into washer/disinfector in accordance with the instructions provided.

■ CAUTION: The operator is responsible for monitoring and guaranteeing the standard of disinfection in the routine disinfection cycle. Disinfection parameters should be checked regularly using chemical indicators, and contamination levels checked and documented periodically using biological indicators.

SAVE THESE INSTRUCTIONS

The G 7782 CD Washer/Disinfector is intended for cleaning and disinfection of dental and general medical instruments and accessories. It cleans and, when using the disinfection cycles, simultaneously thermally disinfects at (93 °C) instruments and accessories.

Areas of effectiveness are physical removal or thermal inactivation of vegetative bacteria including mycobacteria, fungi, fungal spores, and viruses. These categories include the *Mycobacterium tuberculosis* and the *Enterococcus faecium*.

The intended use is identical for processing medical and dental instrumentation. Miele, Inc. considers general medical instruments to be only insignificantly different from dental instruments. Materials used are identical (mostly stainless steel); architectures are simple and very similar.

Important: Only the cycles labeled 'DISINFECTION' disinfect! **Always** use these cycles when handling contaminated items. All other cycles are designed to clean items **without** disinfecting them!

IMPORTANT: Centers for Disease Control Publication PB85-923404, *Guideline for Handwashing and Hospital Environmental Control, 1985*, defines the processing requirements for critical, semi-critical and non-critical instruments. Refer to these definitions to determine when and under what conditions the G 7782 CD Washer/Disinfector can be used.

Guide to the disinfector

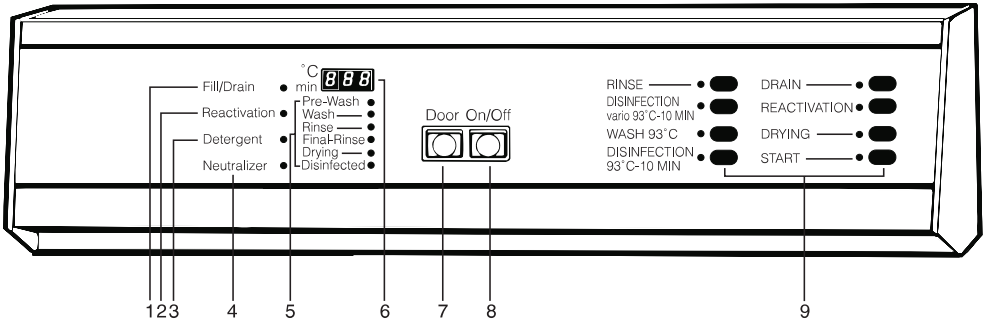

- | | |
|--|---|
| <p>1 CHECK WATER INLET/DRAIN indicator light</p> <p>2 REACTIVATE WATER SOFTENER indicator light</p> <p>3 ADD <u>LIQUID</u> DETERGENT indicator light</p> <p>4 ADD NEUTRALIZING AGENT indicator light</p> | <p>5 Cycle phase indicator lights</p> <p>6 Indicator display field</p> <p>7 Door release button</p> <p>8 On-Off button</p> <p>9 Cycle selector touch pads</p> |
|--|---|

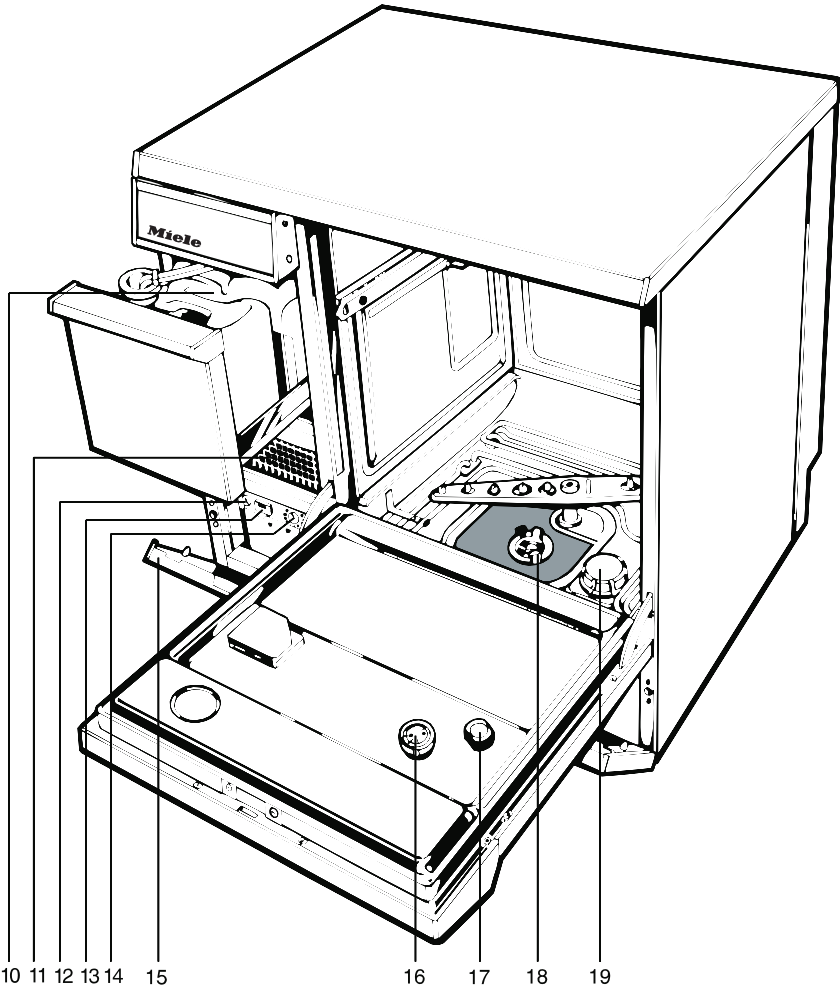

- | | | | |
|----|---|----|--|
| 10 | Dispenser for detergent (blue) and neutralizing agent (red) | 15 | Service panel |
| 11 | Filter assembly | 16 | Dispenser for liquid rinsing agent with dosage selector |
| 12 | Safety fuse (anti-block feature) for drying unit | 17 | Level indicator for rinsing agent |
| 13 | Operating hours counter for drying unit | 18 | Filter combination |
| 14 | Temperature selector for drying unit | 19 | Salt reservoir (water softener) |

Opening and closing the door

To open the door

- Press the DOOR button on the control panel and open the door.

WARNING - BURN HAZARD: Except for emergency, do not open door when cycle is in process. In an emergency, first stop the cycle by pressing ON/OFF button. Press DRAIN touch pad and wait for washer/disinfector to drain. Wear protective gloves and face shield whenever reaching into wash cabinet.

The door should only be opened during cycle operation for emergencies, e.g. if articles are knocking together. (Refer to "Interrupting a cycle".)

WARNING - TIPPING HAZARD: Do not sit or lean on open door.

To close the door

Lift the door upwards and push until it clicks into position. Do not press the DOOR button.

Instruments suitable for processing in the Washer/Disinfector

All instruments, accessories, and other items to be cleaned and disinfected in the G 7782 CD Washer/Disinfector must have the following properties:

- Heat resistance to temperatures of at least 93 °C.
- Corrosion resistance in the presence of heat, alkalinity and water.

Certain items and materials are **not suitable** for processing in the G 7782 CD Washer/Disinfector.

Instruments not suitable for processing in the Washer/Disinfector

- Carbon steel and chrome steel devices as they may corrode.
- Flexible endoscopes.
- Light cables, fiber optics, rotating devices, motors or other electrical equipment unless the device manufacturer approves the processing.

Handpieces, drill bits, grinders, root canal instruments or other rotating instruments only have a limited suitability for the washer/disinfector. Please ask the manufacturer's advice on the suitability for processing in this system.

Rhodium coated specula must be arranged so that their surfaces do not suffer any mechanical damage. Not all specula with glass are suitable for machine treatment.

NOTE: Aluminum devices can only be processed using the DISINFECTION VARIO 93 °C – 10 MIN cycle with Neutral pH Detergent as they may discolor otherwise. Aluminum only has a limited suitability for processing in this system.

NOTE: Always contact the device manufacturer to confirm processing compatibility if you have any concerns about the suitability of a specific item.

 **WARNING – POTENTIAL BIOHAZARD:** Always use DISINFECTION cycles when processing medical and dental instruments and accessories. Only DISINFECTION cycles provide high-level disinfection.

- Please visually inspect instruments and cassettes to make sure they are free from deposits before wrapping and sterilization.

Cleaning Without Disinfection

All other cycles are designed to clean goods without disinfecting them. These programs are:

- RINSE
- WASH 93 °C
- Please refer to “Cycle selection” for detailed information.

Loading the washer/disinfector

CAUTION: Use only accessories specifically designed for this equipment.

The washer/disinfector normally uses an upper and a lower basket.

Depending on the type and shape of the items being cleaned, accessory baskets and inserts can be utilized. Select baskets and inserts which are appropriate for the application (see separate product literature).

Loading accessory baskets/inserts

WARNING - PERSONAL INJURY/EQUIPMENT DAMAGE HAZARD: Empty containers and glassware before placing in the washer/disinfector. Do not allow any acids or solvents, especially hydrochloric acid and chlorides to get into the wash cabinet.

WARNING - PERSONAL INJURY HAZARD: Be careful when sorting instruments with sharp pointed ends. If possible, place pointed end downwards.

1. Empty all items to be cleaned before loading into the basket or insert.
2. Remove gross soil/debris from all items to be cleaned before loading into the basket or insert.
3. Load the items to be cleaned so the water will come into contact with all surfaces. This ensures that they will be properly cleaned and disinfected.
 - Do not place items to be cleaned inside other pieces where they may be concealed.
 - Vessels should be inverted and placed in the correct accessory inserts.
 - Deep-based items should be placed at enough of an angle for water to run off them freely.
 - Tall and narrow pieces should be placed in the center of the basket to ensure good coverage with water.
4. In order to avoid corrosion, it is recommended that only heat and corrosion resistant items be cleaned in the washer/disinfector. For the suitability of instruments, please refer to "Instrument Guidelines".
5. The spray arms must not be blocked by items which are too high for the basket or which hang down. If necessary, manually rotate the spray arms to test it.

Loading the washer/disinfector

Loading the washer/disinfector

WARNING - FALL HAZARD: To prevent falls, keep floors dry by immediately wiping up any spilled liquids in washer/disinfector loading and unloading areas.

CAUTION: Load baskets and inserts into washer/disinfector in accordance with the instructions provided.

Care should be taken to remove (dental) cement or amalgam from the instruments. However, where necessary, the instruments can be cleaned manually after thermal disinfection (following health and safety regulations) with minimized danger.

Make sure the spring loaded coupling engages correctly when the upper basket is inserted into the washer/disinfector. There should be a tight fit between the coupling and the water inlet connector at the top of the chamber. If there is not, adjust the adapter as follows:

- Loosen the holding ring on the upper basket.
- Push up the adapter so it is 1/4" higher than the water inlet connector, and tighten the holding ring.

Adjustable upper basket

Adjustable upper baskets can be used in this machine. They can be raised or lowered by $\frac{3}{4}$ " (2 cm) from the initial setting. In the middle position, the upper basket will accommodate:

- instruments, utensils, accessories and inserts up to $7\frac{1}{2}$ " (19 cm) in height

while the lower basket can accommodate:

- instruments, utensils, accessories and inserts up to $9\frac{13}{16}$ " (25 cm) in height.

For further details regarding container height combinations, see table below.

Top basket position	Top basket height		Bottom basket height	
	(cm)	(inches)	(cm)	(inches)
top	17	$6\frac{11}{16}$	27	$10\frac{5}{8}$
middle	19	$7\frac{1}{2}$	25	$9\frac{13}{16}$
bottom	21	$8\frac{1}{4}$	23	$9\frac{1}{16}$

To adjust the upper basket

- Pull out the upper basket until a resistance is felt, lift from the runners and remove.

Unscrew the knurled nuts on both sides of the basket and reposition as necessary.

Loading examples

Loading examples

Miele offers a wide variety of baskets and inserts for many medical and dental applications.

Please see the following pages for instructions on loading specific baskets / inserts.

Please contact a Miele representative for recommendations on the appropriate basket / insert for your cleaning needs.

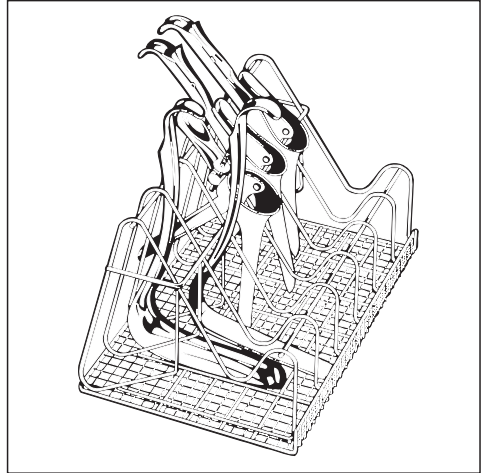

E-414 **1/4 ENT Insert**

For speculums used in gynecological applications. Load as illustrated.

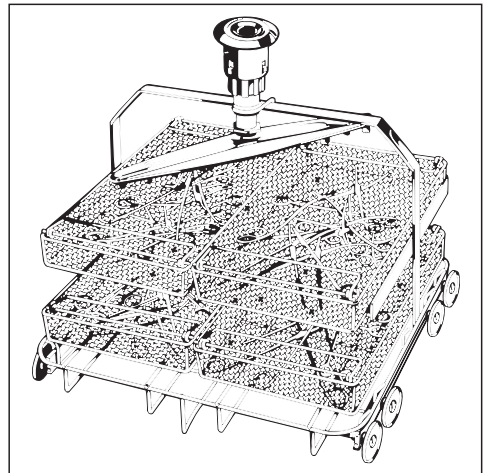

E-327 **2-Level Mobile Unit**

with 2 levels for mesh trays. Unit is sold separately from mesh baskets in the illustration.

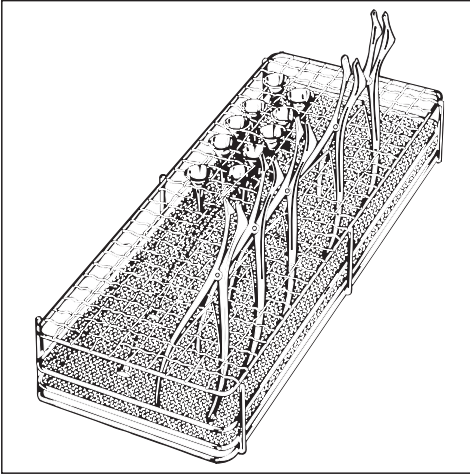

E-417
 $\frac{2}{5}$ ENT Insert

For ear and nose speculums. Load as illustrated to ensure that speculums are open for cleaning.

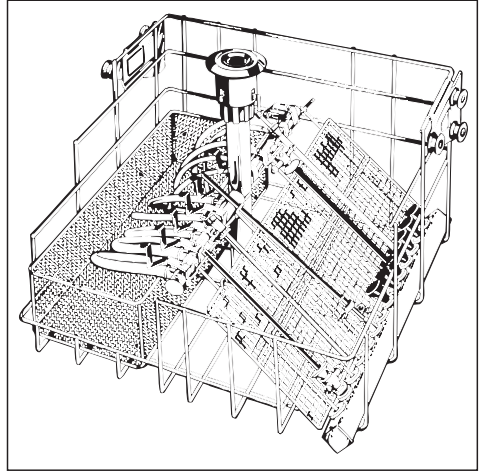

E-176
Upper basket with Drying Connection for rigid endoscopes

Right-hand side: 14 jets/funnels for parts of rigid endoscopes, max. length 50 cm. 10 jets with clips are fitted for catheters.

Left-hand side: mesh basket for loose instruments (sold separately).

Loading examples

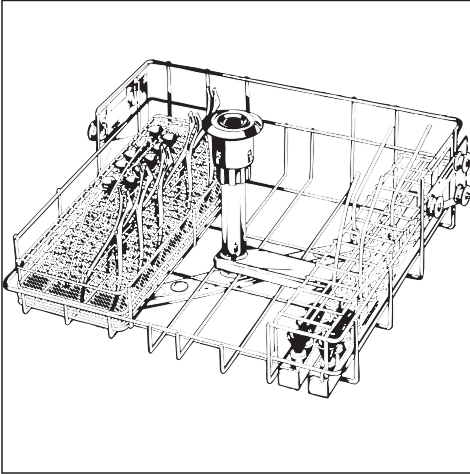

Upper basket O 177

The upper basket O 177 features 28 jets/funnels for direct injection of hollow instruments like syringe tips or evacuation tips. The left side is free for alternative inserts (sold separately).

Place hollow instruments directly onto the jets. If the inner diameter of the hollow instruments do not allow for positioning onto the jets, the jets may be replaced by funnels.

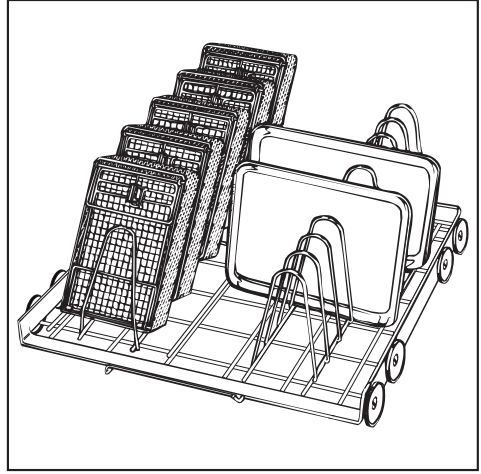

Lower basket U 874

Inserts sold separately:

Left side: insert E 131 for 5 mesh trays (E 146 - $2 \frac{5}{32}'' \times 5 \frac{7}{8}''$) and holders (E 328) for double sided instruments.

Right side: E 130 insert for 10 trays.

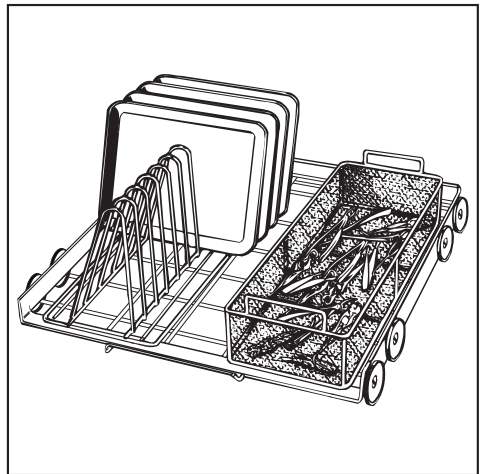

Lower basket U 874 insert

Left side: E 130 insert for 10 trays.

Right side: E 379 universal mesh tray for various loose instruments.

Loading examples

Additional baskets, inserts and accessories not pictured:

O190	Standard upper basket
E 363	Mesh tray with lid for various instruments ($1/32$ " wire mesh)
E 378	Insert for lower basket. Full size mesh tray (for various instruments) without lid
E 338	Insert for lower and upper basket – for 8 half trays
E 441	Instrument container ($1\ 31/32$ " x $7\ 1/16$ ")
E 417	Insert for lower basket – for miscellaneous items
E 373	Mesh tray with instrument holders
E 339	Insert for lower basket – for 16 tray bases
E 308	Insert for lower basket – for 7 half trays

MIS injector mobile unit E 450

Loading instructions

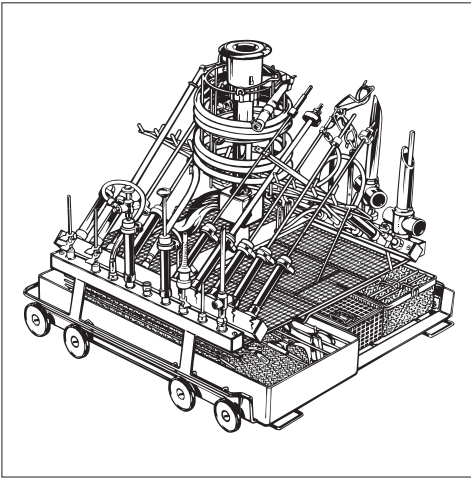

Important:
The "Warnings and Safety instructions" pages must be observed.

WARNING - PERSONAL INJURY/EQUIPMENT DAMAGE HAZARD: Internal cleaning and disinfecting to a measurable standard can only be achieved with instruments that can be dismantled and where the jets, sleeves and adapters are used appropriately. A special examination, over and above a visual one, of the cleanliness of the inner area of the instruments should be made. MIS instruments should preferably be processed using the DISIN VARIO 93°C-10 MIN or DISIN 93°C-10 MIN program with recommended detergents.

- Put 5 mm and 10 mm Ø shafts into the appropriate sleeves (E-442 or E-443).
- Do not load the lower levels with more inserts than as shown above in the example (from left to right E-457, E-460, E-451)
- Trocars of a wider diameter will be cleaned more effectively in the front or the rear position of the row of jets.

Other accessories and fitting not pictured:

- E 442 5 mm Ø injection sleeve
- E 443 10 mm Ø injection sleeve
- E 445 caps for E 442 sleeves
- E 446 caps for E 443 sleeves
- E 447 Adapter for Luer lock (female)
- E 452 Injector jet Ø 2.5 x 60 mm
- E 362 Blanking screw
- E 444 Insert for fiber optic (cold-light) cable or suction hose

Loading examples

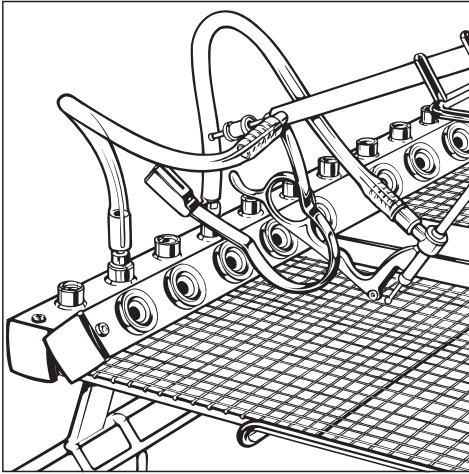

- Connect MIS instruments which cannot be dismantled, and have an irrigation channel connector, to the water circuit with the E-448 tube with Luer lock adapters, so that they lie at an angle.

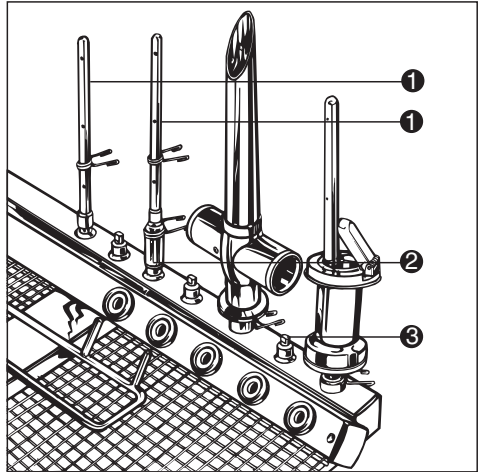

- Take apart trocar sleeves and push on to the corresponding injector jets.
E-454 **1** for Trocar sleeves 10-15 mm Ø
E-464 **2** with E-454 **1** for Trocar sleeves >15 mm Ø.
Using the clamp springs, the sleeves or the flap valve can be positioned in such a way that critical areas such as for example the side piston shoe, can be washed by the jet openings on the side or the jet spray of the E-454.
- Important:
To maintain wash pressure every opening must be fitted either with an item to be cleaned or a blanking screw **3**.

MIS injector mobile unit E 450

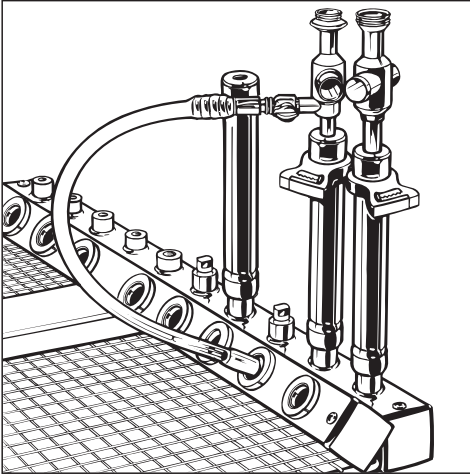

- Fit the trocar or instrument sleeves < 10 mm Ø into sleeve E-336 or on to jet E-453. Trocar sleeves with a side connection should be attached via the E-448 tube with Luer lock adapters.

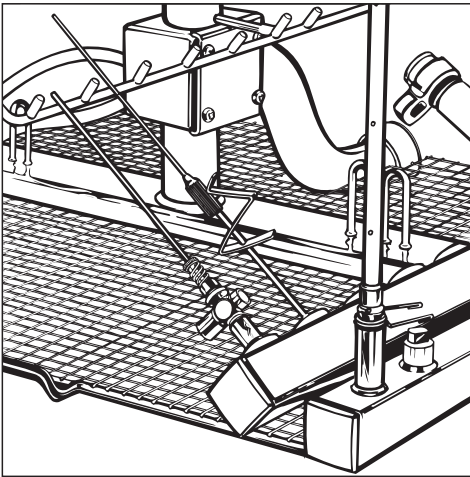

- Connect narrow (Veress) cannulae so that they lie at an angle with Luer lock adapters E-449, or fix on the jet with a spring clip.

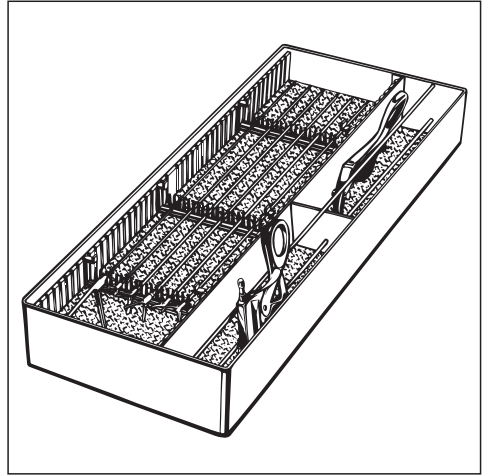

E-457 Insert for separable MIS instruments

- Place the handles of modular shaft instruments into the side compartments
- Then clamp the connection end of the functional parts into the plastic clip. Open the working ends and fix the functional part into one or two further clips.

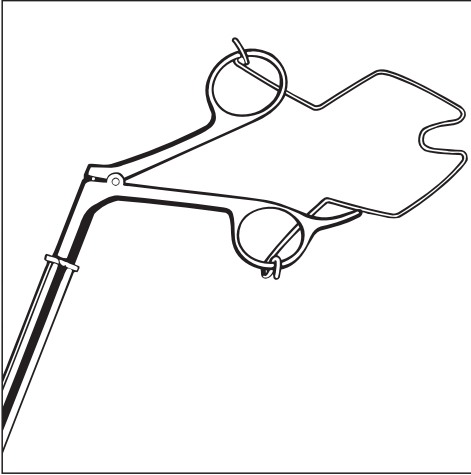

Opening spring E-456

For MIS instruments which are sprung to stay closed and cannot be taken apart, scissors, forceps etc., and must be held open in the wash jet sleeve. Use the opening spring if appropriate.

Optics insert (not illustrated)

- Only optics which are safeguarded by the manufacturer against mechanical damage may be processed in special inserts such as the E-460 or corresponding optic manufacturer's inserts.
- Assurance is needed from the manufacturer that optics and fiber optic (cold-light) cables can be thermally treated. Pre-treatment conditions must be observed. DISIN VARIO 93°C-10 MIN or DISIN 93°C-10 MIN process with de-ionized water final rinse is recommended.

If you have any questions relating to applications technology please contact Miele's Professional Division:

USA 1-800-843-7231
products@mieleusa.com

CDN 1-800-565-6435

Adding detergent

Priming the liquid dispensing system

Before using the washer/disinfector for the first time, or if the washer/disinfector has been operated with an empty detergent container, the dispensing system must be primed. Please proceed as follows:

1. Press the ON/OFF button to turn the washer/disinfector off.
2. Open the door slightly so that the priming switches are visible.

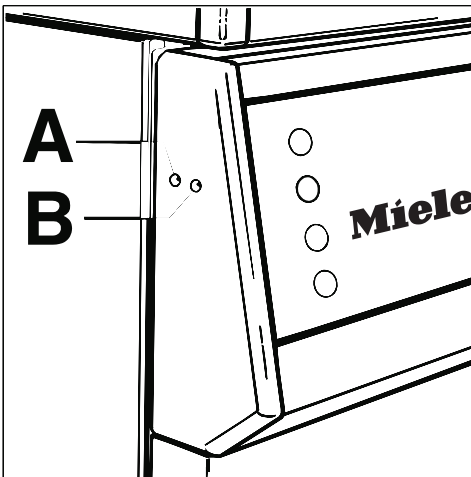

3. Using a long, thin object (e.g., straightened paper clip), press in switch "B", located on the left end of the control panel, for 3 1/2 minutes.

Each time the system is primed, any detergent which runs into the wash cabinet must be washed out by running the RINSE cycle.

After this cycle is run, the dispensing system is filled and ready for use.

Adding detergent

**WARNING - PERSONAL INJURY/
EQUIPMENT DAMAGE HAZARD:**
Only use detergents which have
been approved by Miele. Use of any
other products may cause personal
injury, invalidate the disinfection re-
sults or void the washer/disinfector
warranty.

**WARNING - CHEMICAL BURN
HAZARD:** Wear protective gloves
and goggles and use care when
handling liquid detergents. Read
and follow the instructions and
safety procedures on the packaging
and in the **Material Safety Data
Sheet (MSDS)**.

Use of Alkaline detergent* or Neutral
pH detergent* in a liquid form is recom-
mended.

* *Contact your Miele representative for
ordering information.*

1. Place the detergent container in the
dispensing unit next to the washer
chamber.
2. When the Detergent indicator on the
control panel lights up, either fill con-
tainer with more detergent or replace
the empty container with a full one.
3. Place the siphon tube from the deter-
gent dispensing pump firmly in the
opening of the detergent container (see
illustration). The siphon tube may be
cut so that the bottom of the tube lies
about 1" above the bottom of the con-
tainer.



Adding neutralizing rinse

Priming the neutralizer dispensing system

Before using the washer/disinfector for the first time, or if the washer/disinfector has been operated with an empty neutralizer container, the dispensing system must be primed. Please proceed as follows:

1. Press the ON/OFF button to turn washer/disinfector off.
2. Open the door slightly so that the priming switches are visible.

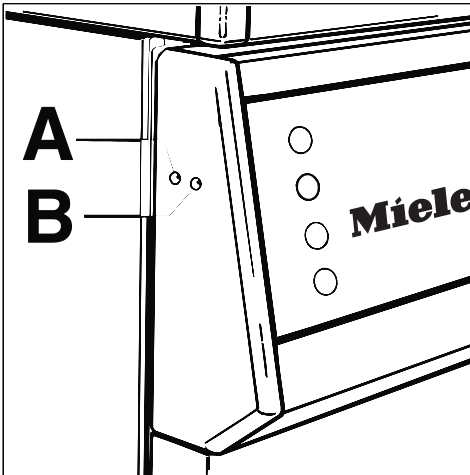

3. Using a long, thin object (e.g., straightened paper clip), press in switch "A", located on the left end of the control panel, for 3¹/₂ minutes.

Each time the system is primed, any neutralizer which runs into the wash cabinet must be washed out by running the RINSE cycle.

After this cycle is run, the dispensing system is filled and ready for use.

To reduce the pH level of the wash solution after the wash phase, the machine dispenses neutralizer during Interim Rinse I.

Adding neutralizing rinse

WARNING - CHEMICAL BURN HAZARD: Wear protective gloves and goggles and use care when handling neutralizing agents. Read and follow the instructions and safety procedures on the packaging and in the **M**aterial **S**afety **D**ata **S**heet (MSDS).

1. Place the Neutralizer container in the dispensing unit next to the washer chamber.
2. When the NEUTRALIZER indicator on the control panel lights up, either fill container with more neutralizer or replace the empty container with a full one.
3. Place the siphon tube from the neutralizer dispensing pump firmly in the opening of the neutralizer container (see illustration). The siphon tube may be cut so that the bottom of the tube lies about 1" abo



Cycle selection

Cycle	Application	Detergent
		Please follow manufacturer's instructions.
RINSE	To rinse heavily soiled instruments e.g. after soaking them in a disinfecting agent to avoid the build-up of foam in the machine.	None
DISINFECTION VARIO 93°C-10 MIN	For protein soils (such as blood and secretions) - for cleaning and thermal disinfection with 93°C and 10-minute holding time for instruments which are susceptible to chemicals and changes in temperature.	Neodisher FA or Medizym may be dispensed
WASH 93°C	Cleaning of instruments at 93°C with 3-minute holding time. NO DISINFECTION	Neodisher FA or Medizym may be dispensed
DISINFECTION 93°C-10 MIN	For protein soils (such as blood and secretions) - for cleaning and thermal disinfection with 93°C and 10-minute holding time for instruments which are susceptible to chemicals and changes in temperature.	Neodisher FA or Medizym may be dispensed

WARNINGS AND SAFETY INSTRUCTIONS

G 7782 CD Washer/Disinfector

To the person responsible for this machine:

- Make this pull-out with the Warning and Safety Instructions available to any operators of the machine. Place it near the machine, where it can be seen.
- Ensure that operators know and understand these Warning and Safety Instructions, and observe them in use.

The following is a summary of the safety precautions, which must be observed when operating and servicing this equipment. These precautions are repeated (in whole or in part), where applicable throughout the manual.

All relevant safety procedures must be obeyed. Relevant safety procedures include, but are not limited to, the Centers for Disease Control's Recommended Infection Control Practices and the OSHA Bloodborne Pathogens Standard.

READ ALL INSTRUCTIONS BEFORE USING THE APPLIANCE

WARNING -

The manufacturer cannot accept responsibility for damage caused when the appliance is not used according to the instructions, or for uses other than those for which it was intended.

The manufacturer cannot be held responsible for problems or injuries resulting from improper installation, use or operation of this equipment.

WARNINGS AND SAFETY INSTRUCTIONS

■ **WARNING - PERSONAL INJURY HAZARD:** Do not allow small children or unauthorized personnel access to the washer/disinfector or its controls.

■ **WARNING - EXPLOSION HAZARD:** Do not install the washer/disinfector in areas where flammable compounds/vapors are present.

■ **WARNING - PERSONAL INJURY/EQUIPMENT DAMAGE HAZARD:** Repair work must be carried out only by a qualified and competent service technician. Repairs by unqualified persons or installation of unauthorized parts could cause personal injury, result in costly equipment damage or void the washer/disinfector warranty.

■ **WARNING - BURN HAZARD:** Except for an emergency, do not open door when cycle is in process. In an emergency, first stop the cycle by pressing the ON/OFF button. Press the DRAIN touch pad and wait for washer/disinfector to drain. Wear protective gloves and face shield whenever reaching into wash cabinet.

■ **WARNING - ELECTRICAL SHOCK HAZARD:** Disconnect all utilities to equipment before servicing. Do not service equipment unless all utilities have been properly locked out.

■ **WARNING - PERSONAL INJURY/EQUIPMENT DAMAGE HAZARD:** Only use detergents which have been approved by Miele. Use of any other products may cause personal injury, invalidate the disinfection results or void the washer/disinfector warranty.

■ **WARNING - PERSONAL INJURY HAZARD:** The water in this washer/disinfector is not suitable for drinking.

■ **WARNING - PERSONAL INJURY HAZARD:** Be careful when sorting instruments with sharp pointed ends. If possible, place the pointed end downwards.

■ **WARNING - CHEMICAL BURN HAZARD:** Wear protective gloves and goggles and use care when handling liquids such as detergents or neutralizing agents. Read and follow the instructions and safety procedures on the packaging and in the **Material Safety Data Sheet (MSDS)**.

WARNINGS AND SAFETY INSTRUCTIONS

■ **WARNING - PERSONAL INJURY/
EQUIPMENT DAMAGE HAZARD:**
Empty containers and glassware before placing in the washer/disinfector. Do not allow any acids or solvents, especially hydrochloric acid and chlorides, to get into the wash cabinet.

■ **WARNING - PERSONAL INJURY/
EQUIPMENT DAMAGE HAZARD:**
Internal cleaning and disinfecting to a measurable standard can only be achieved with instruments that can be dismantled and where the jets, sleeves and adapters are used appropriately. A special examination, over and above a visual one, of the cleanliness of the inner area of the instruments should be made. Minimally invasive surgical (MIS) and dental instruments should preferably be processed using the DISIN VARIO 93°C-10 MIN or DISIN 93°C-10 MIN program with recommended detergents.

■ **WARNING - BURN HAZARD:** Allow accessories to cool to room temperature before unloading. Any water which may have collected in incorrectly loaded items will be very hot and should be emptied into the wash cabinet.

■ **WARNING - BURN HAZARD:**
Do not touch the heating elements in wash cabinet after the end of a cycle.

■ **WARNING - TIPPING HAZARD:** Do not sit or lean on the open door. This could cause the washer/disinfector to tip.

■ **WARNING - FALL HAZARD:**
To prevent falls, keep floors dry by immediately wiping up any spilled liquids in washer/disinfector loading and unloading areas.

■ **WARNING - ELECTRIC SHOCK
HAZARD:** Washer/disinfector must be correctly grounded!

■ **WARNING - POTENTIAL
BIOHAZARD:** Always use DISINFECTION cycles when processing dental or medical instruments and accessories. Only DISINFECTION cycles provide high levels of disinfection.

■ **WARNING - PERSONAL INJURY/
EQUIPMENT DAMAGE HAZARD:**
Do not fill the white cylindrical container with cleaning detergent! Fill with reactivation salt only! Otherwise the pressurized container may cause injuries by unscrewing.

WARNINGS AND SAFETY INSTRUCTIONS

■ If thermal disinfection is required (93 °C / 10 min.), the process needs to be checked and documented regularly. This can be done by checking the disinfection control diode on the machine. Alternatively, a chemical indicator may be used (e.g. the Disinfection Control Tubes by A. Browen Ltd., supplied by Miele). These disinfection control tubes should be placed in the filter combination. After the disinfection cycle, they may be inspected by removing the coarse filter.

■ CAUTION: Washer/disinfector must not be used without all filters in place.

■ CAUTION: Use only accessories specifically designed for this equipment. Load accessories into washer/disinfector in accordance with the instructions provided.

■ CAUTION: The operator is responsible for monitoring and guaranteeing the standard of disinfection in the routine disinfection cycle. Disinfection parameters should be checked regularly using chemical indicators, and contamination levels checked and documented periodically using biological indicators.

SAVE THESE INSTRUCTIONS

Cycle selection

Cycle phase					
1. Pre-rinse	2. Cleaning and/or thermal disinfection	3. Interim rinse I (with neutra- lization)	4. Interim rinse II	5. Final rinse and/or disinfec- tion	6. Drying phase
X					
X	X 45°C	X	X	X 93°C (AD*)	(X)
	X 93°C	X	X	X 80°C (AD*)	(X)
	X 93°C	X	X	X 80°C (AD*)	(X)

X = Cycle phase included

(X) = Programming option

* **AD (Aqua destillata)** = Deionized water

Washer/Disinfector operation



WARNING - PERSONAL INJURY HAZARD: Do not allow small children or unauthorized personnel access to the washer/disinfector or its controls.

NOTE: Provided the **START** touch pad has not yet been pressed, a mistakenly selected cycle may be changed by pressing the appropriate touch pad to select the correct cycle, then pressing the **START** touch pad.

Cycle Operation

1. Turning on

- Press ON/OFF button.

2. Loading washer/ disinfector

Load accessories and washer/disinfector as explained in "Loading the washer/disinfector".

3. Selecting a cycle

After turning on the washer/ disinfector, the indicator lights next to the available cycles will light.

- Press the touch pad for the required cycle. The wash temperature of the selected cycle will show in the display field and phase indicator lights for selected cycle will light.
- If drying cycle is desired, press **DRYING** touch pad (see "Selecting an additional cycle").

4. Running a cycle

- Press the **START** touch pad. The display field will show the total processing time in minutes for the selected cycle and the washer/disinfector will begin cycle operation.

NOTE: Once **START** is pressed, all other cycles are blocked and only the indicator lights for the selected cycle are lit.

- During the heating stage in **WASH** and **FINAL RINSE**, the end temperature will be alternately displayed on the control panel.

Washer/Disinfector operation

5. Turning off

- Once a cycle is complete, press the ON/OFF button. The washer/disinfector can now be unloaded. (Refer to "Unloading the washer/disinfector").

WARNING - BURN HAZARD: Do not touch the heating element.

6. Please visually inspect instruments and cassettes to make sure they are free from deposits before wrapping and sterilization.

Cycle phase indicators

When a wash or disinfection cycle has been selected, the phase indicator lights on the control panel will show the cycle sequence.

When a phase of the cycle is completed, the corresponding indicator light goes out. The wash cycle is completed when the START light goes out.

Selecting an additional cycle

The following additional cycles are available:

DRYING

NOTE: The heat retention capacity of stainless steel allows for fast drying. Plastic has a lower heat retention capacity, thus needing a longer drying time. In this case, a slightly extended drying period of 15 minutes may be necessary.

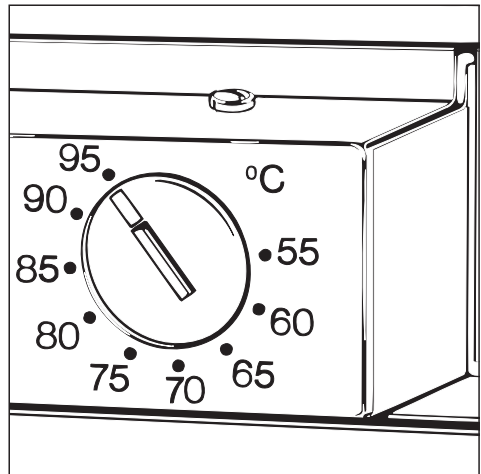

Washer/Disinfector operation

This cycle may be selected immediately after choosing a processing cycle (exception: RINSE cycle). By pushing the DRYING touch pad repeatedly, the drying time will extend in 15 minute increments from 0 to 90 minutes. The time currently set is shown in the display field. The total running time of the cycle will be lengthened accordingly.

The drying temperature is pre-set at 95°C. The temperature can be changed from 55°C to 95°C in 5°C increments using the dial located on front of drying unit behind the front panel.

***NOTE:** To prevent corrosion, the drying cycle should be set to a time and temperature that ensure thorough drying after the wash and disinfection cycle.*

REACTIVATION

See "Reactivating the water softener"

DRAIN

Use the DRAIN cycle in case there is water left in the wash chamber at any time. For more information see "Washer / Disinfector operation - Interrupting a cycle".

1. Press the ON/OFF button.
2. Press the DRAIN touch pad.
3. Press the START touch pad.

Interrupting a cycle

Once a cycle is running, it should only be interrupted in extreme cases, such as when articles in the washer/disinfector rattle or bump against each other and have to be rearranged.

WARNING - BURN HAZARD: Except for emergency, do not open door when cycle is in process. Wear protective gloves and face shield whenever reaching into wash cabinet.

If cycle interruption is necessary, please follow these instructions:

- Turn the machine off by pressing the ON/OFF button.
- Press the DRAIN touch pad.
- On completion, open the door and rearrange the articles securely and correctly.
- Close the door. Reselect the cycle and press START button.

IMPORTANT: The disinfection cycle should not be interrupted, as this would affect the disinfection result. If interruption is necessary, the entire cycle must be repeated.

Unloading the washer/disinfector

1. When the cycle is finished, the indicator light next to the START touch pad will go out.
2. If one of the DISINFECTION cycles was chosen, check the DISINFECTED indicator light. If it is not lit, the load is not disinfected! In this case, please call for technical assistance.
3. Check, if any warning lights (left hand side of the control panel) are on, or if the display field shows two dashes. If so, refer to the section "Troubleshooting", or call for technical assistance.
4. Open the door partially (about 4 inches [10 cm]). Let the load cool down for about 10-15 minutes. During this time the load will usually dry. If drying cycle is selected, it is still recommended to open the door partially to let instruments cool.
5. Safely unload the washer/disinfector.

WARNING - FALL HAZARD: To prevent falls, keep floors dry by immediately wiping up any spilled liquids in washer/disinfector loading and unloading area.

WARNING - BURN HAZARD: Allow accessories to cool to room temperature before unloading. Any water which may have collected in incorrectly loaded items will be very hot and should be emptied into wash cabinet.

Programming special functions

The following special functions can be programmed where appropriate:

1. Extending the water inlet from 60 seconds to 120 seconds with level control

If the inlet water pressure is lower than 35 psi (2.5 bar), too little water will flow into the wash cabinet. By selecting the extended water inlet, more water will flow into the wash cabinet if there is low water pressure (between 15 and 35 psi [1.0 and 2.5 bar]).

- Turn off the washer/disinfector.
- Press DRAIN and DRYING touch pads at the same time, while turning on the machine. "Pxx" appears in the display field.
- Press DISINFECTION 93°C -10 MIN touch pad.
"10" or "11" will appear in the display.
10 = 60 seconds water intake
11 = 120 seconds water intake
with level control
- Press DRYING touch pad to change the display to "11".
- Press START touch pad. "SP" appears in the display field.
- Press START again. The change is now stored and the display field clears.

2. Deactivating of neutralizer dispensing

The G 7782 CD is programmed from the factory to dispense neutralizer during the first interim rinse. It is strongly recommended to use this option to avoid discoloration or corrosion of instruments. However, dispensing of neutralizer might not be necessary if a pH neutral detergent is being used.

To deactivate the neutralizer setting perform the following.

- Turn off the washer/disinfector.
- Press DRAIN and DRYING touch pads at the same time, while turning on the machine. "Pxx" appears in the display field.
- Press WASH 93°C touch pad.
"20" or "21" will appear in the display field.
20 = without interim rinse I
21 = with neutralizing agent dispensed in interim rinse I
- Press DRYING touch pad to change from 21 to 20 or vice versa.
- Press START touch pad. "SP" appears in the display field.

Press START again. The change is now stored and the display field clears.

WARNING - ELECTRIC SHOCK HAZARD: Disconnect all utilities to equipment before servicing. Do not service equipment unless all utilities have been properly locked out.

WARNING - PERSONAL INJURY/EQUIPMENT DAMAGE HAZARD: Repair work must be carried out only by a qualified and competent service technician. Repairs by unqualified persons or installation of unauthorized parts could cause personal injury, result in costly equipment damage or void the washer/disinfector warranty.

Maintaining the filter assembly

The filter assembly in the base of the cabinet must be inspected and cleaned regularly.

1. Cleaning the coarse filter

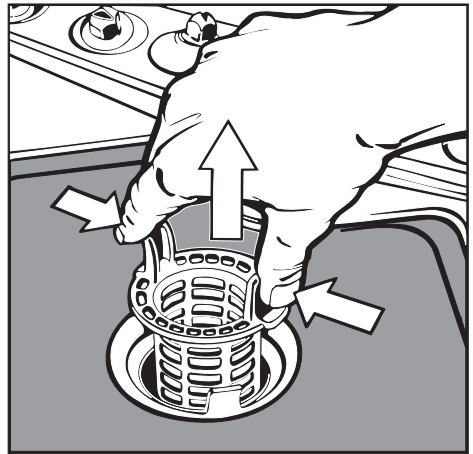

- Press the 2 tabs together, remove and clean the filter. Put the clean filter back in position and press until it clicks in place.

Cleaning and care

2. Cleaning the fine, flat and micro fine filters

- Remove the coarse filter.
- Remove the fine filter from between the flat and the micro-fine filters.

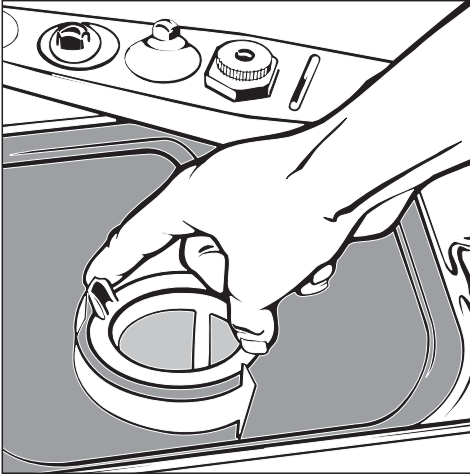

- To unscrew the micro-fine filter, take hold of the two tabs and turn twice in a counter clockwise direction.

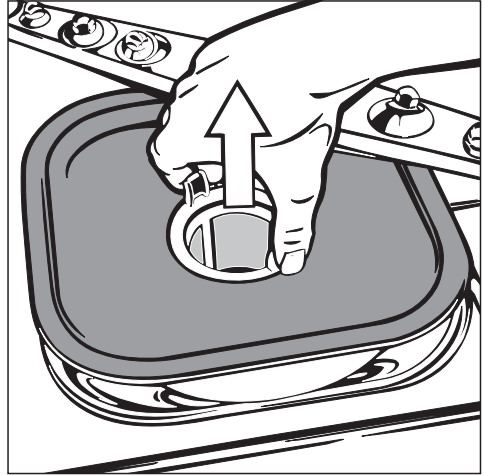

- Pull up and remove the two filters.
- Clean the filters.
- The filter assembly is then replaced in the reverse order in which it was removed.

CAUTION: The washer/disinfector must not be used without all filters in place.

3. Cleaning the water inlet filters

Filters are incorporated into the stainless steel housing located between the supply valve and the hose.

The filters must be cleaned when dirty, otherwise insufficient water will flow into the wash cabinet. These filters must be periodically inspected based on the quality of incoming water.

- Turn off the valves.
- Unscrew the water inlet hoses.

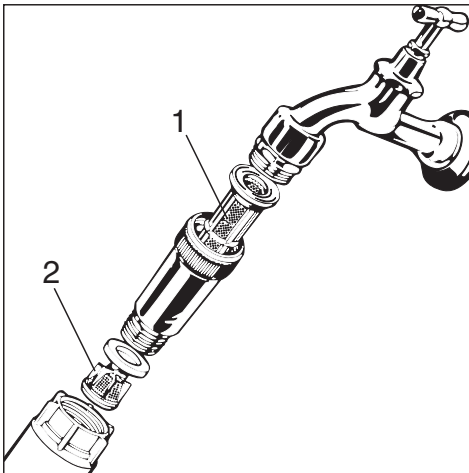

- Clean the large area filter (1) and the fine filter (2) or replace if necessary.
- After reconnection, turn on the valves and test for leaks.

Maintaining the dispensing system

The dispensing system should be maintained at regular intervals in order to guarantee optimum safety and efficiency.

- The tubes in the dispensing system should be replaced every 2 years.

Cleaning and care

Maintaining the drying unit

To ensure thorough cleaning without recontamination, the air filters have to be exchanged after their life cycle (coarse filter = 100 operating hours, clean room filter = 500 operating hours).

1. Changing the coarse filter

The coarse filter is located on the drying unit behind the unit's front panel, which can be pulled out.

After 100 operating hours, this coarse filter needs to be replaced. Please note the total operating time that is displayed on the drying hour meter on the sticker supplied with the filter.

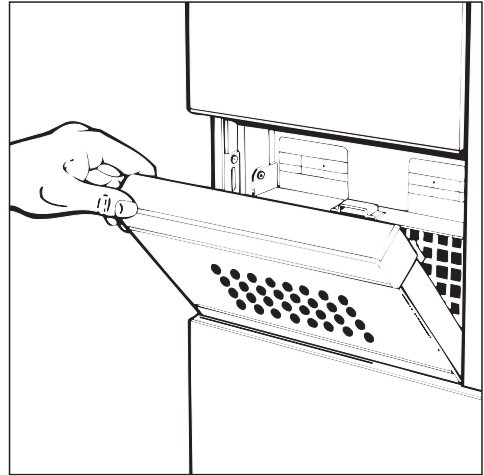

- Grip the inlet grill on the right and left-hand side and pull up out of the retainers. Then pull downwards and remove.

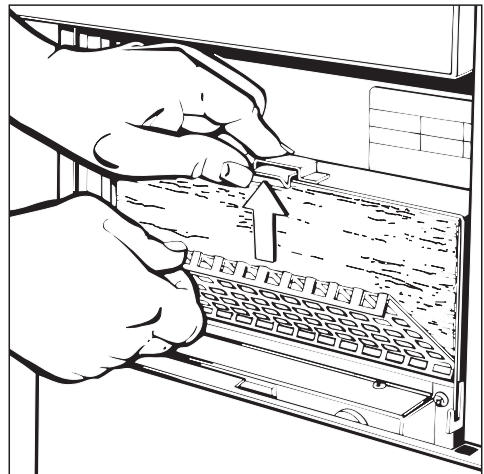

- Remove the perforated plate.

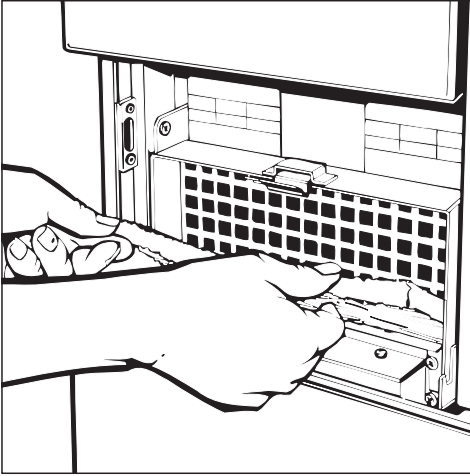

2. Changing the clean room filter

The class 100 HEPA clean room filter has a life cycle of 500 operating hours. It needs to be replaced by specially trained technicians. The time for the next change is written on the sticker on the front of the drying aggregate. Please call the Technical Service Department when the drying hour meter reaches the time specified.

USA 1-800-999-1360
techserv@mieleusa.com

CDN 1-800-565-6435
service@miele.ca

- Change the coarse filter. The smooth side must face toward the rear of the drying unit.
- Reinsert the perforated plate and press into place at the top. The surrounding edge should face forward.
- Replace the inlet grill. The grill should audibly click into place.

Reactivating the water softener

When the REACTIVATION indicator light on the left hand side of the control panel comes on during a cycle, the built-in water softener is depleted and cannot supply any more soft water.

It should be reactivated with salt as soon as the wash cycle has finished. If this cannot be done, and further loads have been washed, then the reactivation process should be carried out twice in succession.

Each reactivation cycle requires:

- 4.4 lbs (2 kg) of water softener salt. Do not use any other type of salt, it may damage the water softener. Softener salt can be ordered from Miele's Technical Service Department.
- The plastic salt container which is supplied with the washer/disinfector.

Filling the salt container

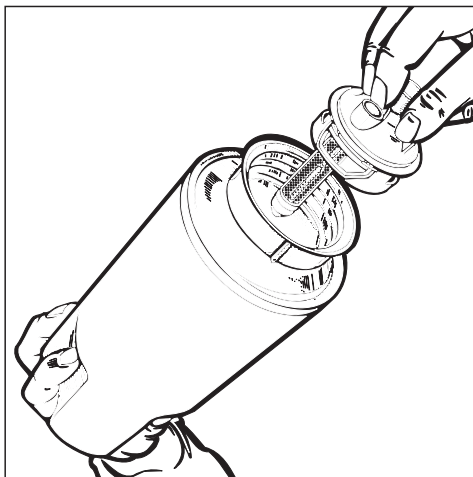

1. Unscrew the filter insert from the salt container and remove.

**WARNING: PERSONAL INJURY/
EQUIPMENT DAMAGE HAZARD**
Do not fill container with cleaning detergent! Fill with reactivation salt only! Detergents can be corrosive, causing potential personal injury and damage to the water softener.

2. Fill the salt container with approx. 4.4 lbs (2 kg) of granular salt and screw the filter insert back in place.

Reactivating the water softener

Position the salt container as follows:

1. Remove the lower basket from the machine.

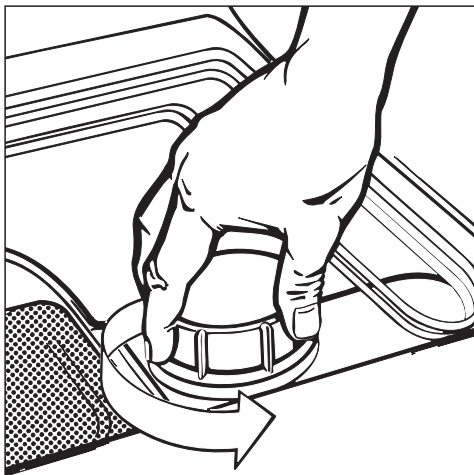

2. Unscrew the plastic cap in the base of the wash cabinet.

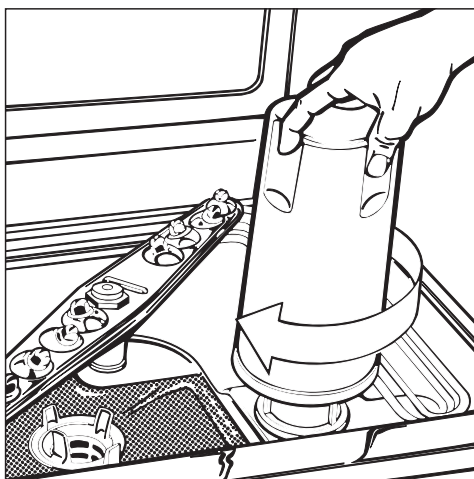

3. Place the salt container on the reactivation socket and screw firmly into place.

4. Close the door.
5. Turn on the washer/disinfector.
6. Press the REACTIVATION touch pad.
7. Press the START touch pad. The reactivation program proceeds automatically.
8. When the REACTIVATION light at the left hand side of the control panel and the START indicator light have gone out, turn off the washer/disinfector.
9. Remove salt container slowly, allowing pressure to be released. Do not open by force. If you cannot unscrew it by hand, contact the Miele Technical Service Department.
10. Screw the plastic lid back on the socket.
11. Reposition the lower basket.
12. Rinse the salt container and filter insert thoroughly.

IMPORTANT: If, after REACTIVATION cycle, salt is still found in the salt container, water pressure may be fluctuating or is below 35 psi (2.5 bar). If this is the case, run the REACTIVATION cycle again to wash all water softener from the salt container.

Troubleshooting

With the aid of the following explanatory notes, minor problems can be corrected without contacting the Miele Technical Service Department.

IMPORTANT: Any work on the washer/disinfector electrical components should only be carried out by a qualified person.

In the event any problems cannot be corrected, please contact the Miele Technical Service Department.

Warning lights

DRAIN/FILL warning light flashes

- Check that both water intake hoses are connected to the water supply and that the valves are turned on.
- Check if inlet water filters are clogged.
- Check the drain hoses. They should be no higher than 3 feet (1 m) from the base level of the washer/disinfector. The inner diameter of the hoses should be no less than 3/4" (2 cm).
- Check if any hoses are kinked. If so, straighten.
- Activate DRAIN cycle. Once DRAIN is complete, restart processing cycle.

The REACTIVATION light is on

- Replenish the water softener. Please refer to "Reactivating the water softener".

The DETERGENT light is on

- The liquid detergent container has to be refilled.

The NEUTRALIZER light is on

- The neutralizer container has to be refilled.

The display shows two dashes

- Contact the Miele Technical Service Department.
The washer/disinfector must be reset by a trained technician.

Unsatisfactory cleaning results

Unsatisfactory cleaning results may appear as drying spots, or as spots that look like corrosion.

Presumably corrosive spots often are bio-debris. They have the shape of drying spots, blurry edges, and the color of rust. Bio-debris may also appear on surfaces that were not decontaminated before processing.

Please observe:

- Have the instruments been stored in the washer/disinfector for more than 6 hours? If so, please run the washer/disinfector, even partially loaded, within 6 hours of loading the first instrument.
- Was enough detergent used? Please check the dosage of the detergent and adjust, if necessary. Too little as well as too much detergent may deteriorate the cleaning results.
- Can both spray arms rotate easily, when the washer/disinfector is loaded? If not, please rearrange the items to be cleaned in a way so that the spray arms can rotate freely.

The water in the wash cabinet is not heated; the cycle lasts too long

This washer/disinfector has a temperature sensor which will shut off the heating elements in the case of over-heating. This could be caused if large articles cover the heating elements or if the filters in the wash cabinet are blocked.

- Remove the cause of overheating.
- Take off the service panel (see "Installation").
- Press in the blue reset button on the temperature sensor.

If this switch trips repeatedly, contact the Miele Technical Service Department before using the washer/disinfector further.

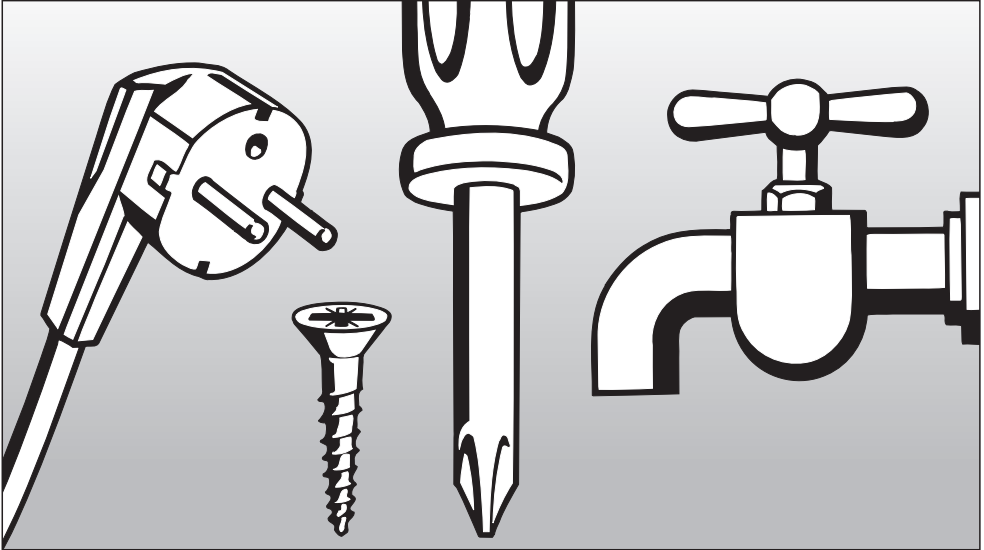

INSTALLATION INSTRUCTIONS

To prevent accidents
and machine damage
read these instructions
before installation or use.

Contents

Help to protect our environment.	51
Installation	52
Electrical connection.	55
Plumbing.	56
Before using for the first time.	58
Adjusting the water softener	59

Help to protect our environment

Disposal of the packaging material

The transport and protective packaging are biodegradable and recyclable.

Please recycle.

Disposal of your old machine

Old appliances may contain materials which can be recycled. Please contact your local recycling authority about the possibility of recycling these materials.

Before disposing, run the DRAIN program to make sure that no residual fluids are left in the sump of the machine.

When disposing of an old machine, remove the door to prevent child hazards.

Installation

WARNING - EXPLOSION HAZARD:
Do not install the washer/disinfector in an area where flammable compounds/vapors are present.

IMPORTANT: The machine should only be installed by a competent contractor. The contractor should be experienced in installing machines that require electrical hook-up as well as plumbing.

The machine can be installed in the following ways:

- Free-standing
- Under counter

The recess should be at least 23 ³/₄" (60 cm) wide, 23 ³/₄" (60 cm) deep, and 33 ¹/₄" (85 cm) high.

Washer/disinfector can be built into a recess of 32 ¹/₄" (83 cm) high by removing the washer/disinfector top.

If necessary the washer/disinfector **lid can be removed** as follows:

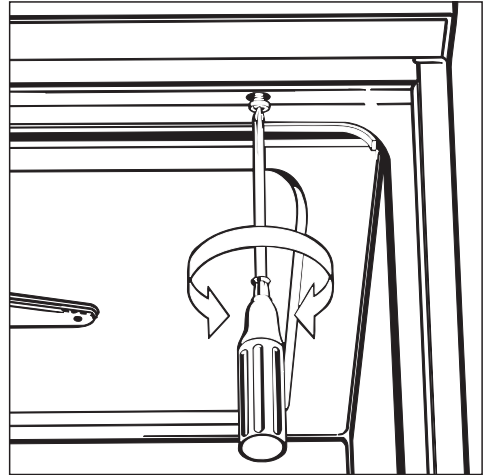

- Open the door.
- Remove the screws on the left and right, using a Philips screw driver.
- Pull the top forward, lift and remove.

By removing the lid, the machine can be built into a recess 32 ¹/₄" (83 cm) high.

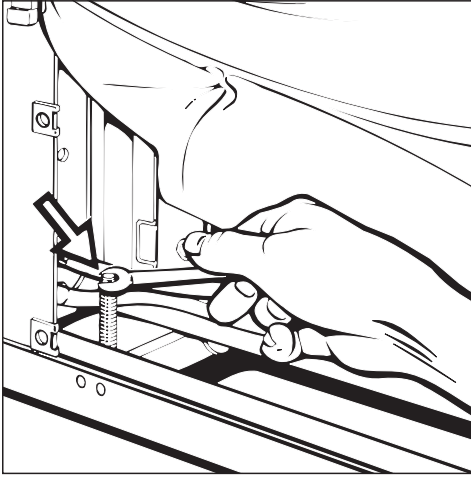

The machine must be installed and leveled correctly. Any unevenness in the floor can be compensated for by screwing the adjustable feet in or out as necessary. To level this unit, the service panel and kickplate must first be removed.

To remove the service panel and kickplate:

- Take hold of the service panel at the top of both sides and pull forward.
- Remove all four kickplate screws.
- Disconnect grounding lead if necessary.
- Remove plastic protective cap.

To re-assemble:

- Replace plastic protective cap, kickplate facing and service panel in the reverse order which they were removed.
- Make sure the grounding lead is re-connected.
- Do not use silicone sealant to seal the gaps between the machine and any neighboring units as this will hinder ventilation to the circulation pump.

Depending on the installation requirements, the following kit is available:

34 $\frac{1}{4}$ " (87 cm) high recess

Steam deflector

For use where the machine will be installed under a wooden countertop. The underside of the work surface is protected from steam damage by a plate of stainless steel (part #1156154.)

Installation

The machine must be installed and leveled correctly. Any unevenness in the floor can be compensated for by screwing the adjustable feet in or out as necessary. To level this unit, the service panel and kickplate must first be removed.

To remove the service panel and kickplate:

- Take hold of the service panel at the top of both sides and pull forward.
- Remove all four kickplate screws.
- Disconnect grounding lead if necessary.
- Remove plastic protective cap.

To re-assemble:

- Replace plastic protective cap, kickplate facing and service panel in the reverse order which they were removed.
- Make sure the grounding lead is re-connected.
- Do not use silicone sealant to seal the gaps between the machine and any neighboring units as this will hinder ventilation to the circulation pump.

Depending on the installation requirements, the following kit is available:

34 $\frac{1}{4}$ " (87 cm) high recess

Steam deflector

For use where the machine will be installed under a wooden countertop. The underside of the work surface is protected from steam damage by a plate of stainless steel (part #1156154.)

Electrical connection

IMPORTANT: All electrical work must be carried out by a qualified electrician and in compliance with all local and national electrical codes.

Before making any connections, check that the voltage shown on the data plate corresponds to your power supply. Data plate is located on back of unit and behind service panel.

The washer/disinfector is supplied as standard for connection to a 208 V, 60 Hz, single phase power supply and is fitted with a power supply cord 6 ft (1.8 m) long with a cross-section of AWG 10-4. Connect washer/disinfector to the main power supply (junction box or electrical cord to outlet) according to the opposite chart.

NOTE: If an electrical cord is used, make sure cord is the proper size and voltage/current rating for the washer/disinfector as identified on the data plate.

Voltage: 208 V, single phase

Frequency: 60 Hz

Rated load: 6.0 kW



Circuit breaker: 30 A per phase

The washer/disinfector can be converted for connection to a 3-phase power supply.

WARNING - ELECTRICAL SHOCK HAZARD: Washer/disinfector must be correctly grounded!

Possibilities of connection:

Single phase



208V 2Ø 60 Hz
6,0 kW  5,4 kW  2x30A

Supply cord: 3 x AWG 10
cord type: S, SE, SO, SOO, ST, STO or STOO

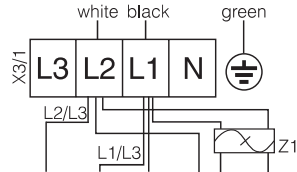
Circuit. pump: 600 W / 0,8 Hp **CD:**
Drain pump: 080 W / 0,1 Hp Fan Heater: 1500 W
Cond. pump: 080 W / 0,1 Hp Fan: 270 W / 0,4 Hp



Three phase

208V 3Ø 4 W 60 Hz
6,0 kW  5,4 kW  3x20A

Supply cord: 4 x AWG 12
cord type: S, SE, SO, SOO, ST, STO or STOO

Circuit. pump: 600 W / 0,8 Hp **CD:**
Drain pump: 080 W / 0,1 Hp Fan Heater: 1500 W
Cond. pump: 080 W / 0,1 Hp Fan: 270 W / 0,4 Hp

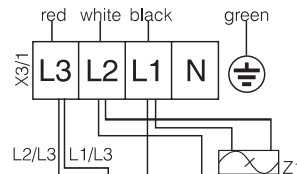

Green must be connected to ground!

The wiring diagram can be found behind the kickplate on the left hand side, attached to the floor of the machine.

The data plate with serial and model numbers is on the rear of the machine and on the kickplate behind the service panel.

Plumbing

Connection to the cold water inlet

- The machine must be connected to the water supply in accordance with local and national plumbing codes.
- The machine is constructed with an air gap/anti-siphoning device on both the intake and the drain sides. No such additional devices are necessary or recommended, as they will impede the water inflow into and out of the washer.
- The water pressure must be between 35 and 145 psi (2.5 - 10.0 bar). If the water pressure is not within this range, the Technical Service Department can advise you of the measures to be taken (see "Programming special functions").
- This machine is designed for cold water connection only. Both inlet hoses (water supply and steam condenser) must be connected to the valves for cold water. Cold water supply must be provided with shut off valves (by others).
- Valves with $\frac{3}{4}$ " male hose thread should be provided near the washer, and should be easily accessible.

- For additional protection of the valves against impurities in the water supply, large surface area filters are enclosed in the kit supplied with the machine (see diagram in "Cleaning and care, Maintaining the filter assembly").
- In installations where a source of DI water is unavailable, it is acceptable to plumb to cold tap water. However, when reprocessing rigid endoscopes, it is strongly recommended to use DI water.

Hose Color	Water type
Blue	Cold water
Green	Deionized water

 **WARNING - PERSONAL INJURY HAZARD:** The water in the washer/disinfector is not suitable for drinking.

Drainage

- The drain system is equipped with a non-return valve which prevents dirty water from flowing back into the washer/disinfector.
- The machine is supplied with two 5 ft (1.5 m) long flexible drain hoses with an inner diameter of 3/4" (2 cm). They should not be shortened or attached to any fittings that would cause a reduction in water flow.
- Longer drain hoses up to a length of 13 ft (3.3 m) are available if required.
- Both hoses can be attached to existing drain lines through the use of a 1 1/2" (3.5 cm) or larger stand pipe / P-trap combination. Alternately, the hoses can be connected directly to existing drain lines, provided any fittings or adapters used do not reduce the water flow.
- The drain hoses must not exceed 13 ft (3.3 m) in length, or be attached to the main drain at a point higher than 3 ft (1 m) above the floor.

A floor drain is permissible.

Before using for the first time

To avoid the build-up of calcium deposits on items being cleaned and disinfected in the washer/disinfector, the water may need to be softened (where the supply hardness exceeds 107 ppm CaCO₃).

To ensure a steady supply of soft water, the water softener must always be:

- correctly set
- regenerated with salt as soon as the REACTIVATION indicator light comes on.

The water softener should be set to correspond with the water hardness upon installation of the washer/disinfector.

Your local water authority can advise you on the water hardness in your area.

Setting the water softener

The hardness range is divided into 18 units and a zero position. The washer/disinfector is set at the factory for a water hardness setting of 8, corresponding to 339 ppm CaCO₃. If your water supply is harder or softer than this, change the setting as follows:

Time setting	gr/gal	mmol/l	° f	°e	ppm CaCO ₃
18	6	1.07	10.7	7.5	107
17	7	1.25	12.5	8.8	125
16	8	1.42	14.3	10.0	143
15	9	1.60	16.0	11.3	160
14	10	1.78	17.9	12.5	179
13	11	1.96	19.6	13.8	196
12	12	2.14	21.4	15.0	214
11	13	2.31	23.2	16.3	232
10	15	2.67	26.8	18.8	268
9	17	3.03	30.4	21.3	304
8	19	3.38	33.9	23.8	339
7	22	3.92	39.3	27.5	393
6	24	4.27	42.8	30.0	428
5	28	4.98	50.0	35.0	500
4	32	5.70	57.1	40.0	571
3	38	6.76	67.8	47.6	678
2	48	8.54	85.7	60.1	857
1	71	12.64	126.7	88.9	1267
0					

Adjusting the water softener

1. Using table provided, identify correct "Display Field" number that corresponds to your local water hardness.
2. Press the DRAIN and DRYING touch pads simultaneously and, while depressed, turn the machine on, using the main ON/OFF switch. "Pxx" will appear in the display field where "xx" can be any value.
3. Press the REACTIVATION touch pad. The "Pxx" will disappear and setting "0" will appear in the display field.
4. Press the DRYING touch pad as many times as necessary for the desired value to appear in the display field.
5. Press the START touch pad. "SP" appears in the display field.
6. Press START once more. The setting will now be stored. The display field clears.

The washer/disinfector is now ready for operation.

If the water hardness in your area is permanently below 107 ppm CaCO₃, you do not need to soften the water. Please deactivate the water softener by selecting the setting "0" in the display field according to above instructions. The REACTIVATION indicator light will not come on and the water softener will not need to be reactivated.

For instructions on reactivating the water softener, see "Reactivating the water softener".

Miele

PROFESSIONAL

Miele, Inc. (USA)

National Headquarters

9 Independence Way
Princeton, NJ 08540
Phone: 800-843-7231
609-419-9898
Fax: 609-419-4298
www.mieleusa.com

Miele Limited (CDN)

National Headquarters

55G East Beaver Creek Road
Richmond Hill, ON L4B 1E5
Phone: 800-565-6435
905-707-1171
Fax: 905-707-0177
www.miele.ca
professional@miele.ca

Technical Service & Support

Nationwide

Phone: 800-999-1360
Fax: 888-586-8056

Mid-West Region

Phone: 847-714-9790
Fax: 847-714-9434

West-Coast Region

Phone: 800-245-8215
Fax: 415-241-6822