



This manual covers the model shown below

NA Model	EU Model	Voltage	Description
88861021	N/A	100~240V	Multi Platform Shaker US plug
88861022	15594060	100~240V	Multi Platform Shaker Intl plug



Before using this product, read this entire operation manual carefully. Users should follow all of the operational guidelines contained in this manual and take all necessary safety precautions while using this product. Failure to follow these guidelines could result in potentially irreparable bodily harm and/or property damage.

Caution all internal adjustments and maintenance must be performed by qualified service personnel.

Material in this manual is for information purposes only. Fisher Scientific is committed to a continuing program of product development and improvement, and reserves the right to change information, such as specifications, appearance, and dimensions, described in this document without notice. Fisher Scientific makes no representations or warranties with respect to this manual. In no event shall Fisher Scientific be held liable for any damages, direct or incidental, arising out of or related to the use of this manual.

No part of this manual may be reproduced or transmitted in any form or by any means, including photocopying, recording, or using information storage and retrieval systems, for any purpose other than the purchaser's own use, without the express written permission of the manufacturer.

Any other product names and services identified in this manual are trademarks or registered trademarks of their respective owners. No such use, or the use of any trade name, is intended to convey endorsement or other affiliation with Fisher Scientific.

© 2017 Fisher Scientific. All rights reserved.

Contents

Section 1 Inspection and Installation	4
Packing List	4
Connections	4
Structure Diagram	4
<hr/>	
Section 2 Overview	5
Specifications	5
Environmental Conditions	5
Safety Instructions	5
Capacity and Speed	6
<hr/>	
Section 3 Operation	7
Control Panel	7
Installation	7
Settings	7
Installation of Accessories	8
<hr/>	
Section 4 Safety Tips and Maintenance	10
<hr/>	
Section 5 Troubleshooting	11
<hr/>	
Section 6 Optional Accessories/Spare Parts	12
<hr/>	
Section 7 Warranty	14
<hr/>	

Section 1 Inspection and Installation

1. Inspect package and contents upon receipt of the instruments. If the package is severely damaged or if there are any missing pieces, please contact the manufacturer immediately.







2. Unpack the instrument, ensure all parts of the instrument and accessories are not missing or damaged. Make sure to take out

all the components before discarding the packing. If there are any missing or damaged pieces, please contact the manufacturer immediately.

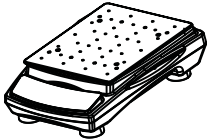
3. Place the instrument on a level and firm surface to avoid vibration and noise.

1.1 Packing List

Table -1 Packing List

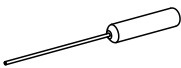
Description	NA Cat. No.	NA/EU Cat. No.	Figure
Multi Platform Shaker	88861021 US plug	88861022 /15594060 Intl plug	
*Universal (Aluminum) Platform	1	1	
General Power Adaptor	1	1	
US Plug	1	N/A	
CN Plug	N/A	1	
EU Plug	N/A	1	
UK Plug	N/A	1	
Screw Driver	1	1	

*Has been installed on the instrument

1.2 Connections

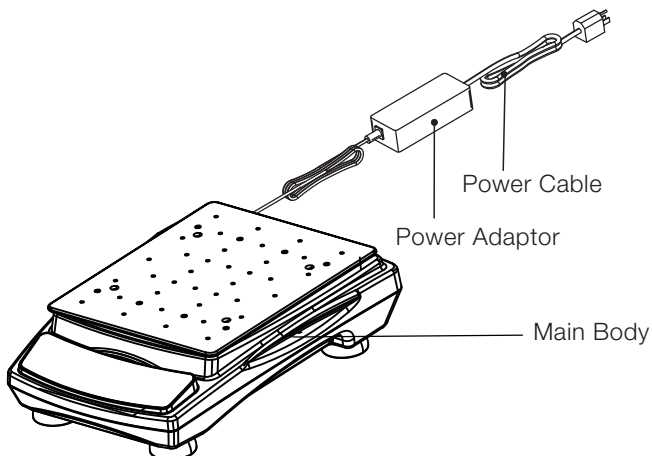

1.3 Structure Diagram

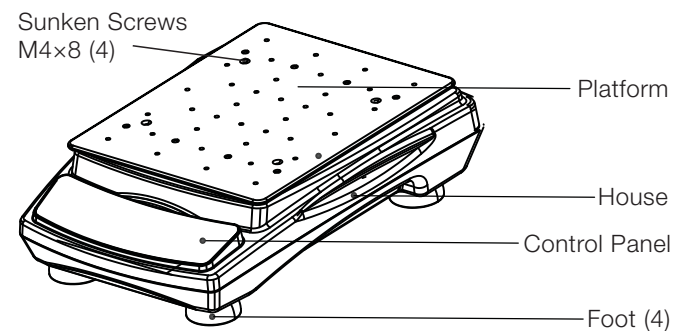

Section 2 Overview

2.1 Specifications

Category Number

Description	NA Cat. No.	NA/EU Cat. No.
Multi Platform Shaker	88861021 US plug	88861022 /15594060 Intl plug

Rotation Speed

Speed Range	50 to 450 rpm (load weight < 3 kg) 50 to 300 rpm (load weight :3 to 4.5 kg)
Orbit Diameter	∅ 10mm(0.4in.)
Speed Accuracy	± 1rpm(≤100rpm) ± 1%(101~450rpm)
Display Mode	LED
Display Accuracy	1 rpm

Note: Maximum speed may vary with heavy or unbalanced loads.

Time

Timing Range	0, 1min~99h59min
--------------	------------------

Load

Maximum Load (Centered on tray)	4. 5kg (10lb)
------------------------------------	---------------

Size

Overall Dimensions	415×293×123mm(16.3×11.5×4.8in)
Platform Dimensions	310×284mm(12.2×11.2in)
Package Dimensions	536×501×346mm(21.1×19.7×13.6in)

Weight

Net Weight	12Kg(26.4lb)
Gross Weight	14Kg(30.8lb)

Power Supply

Requirement	AC100-240V, 50Hz/60Hz, 40VA
-------------	-----------------------------

Others

Certification	ROHS, WEEE, cCSAus, CE Mark
---------------	-----------------------------

2.2 Environmental Conditions

Application Environmental Conditions: indoor use

Temperature	5 to 40°C (41 to 104 °F)
Altitude	≤2,000 m
Humidity	20% to 85%,

Storage Environmental Conditions

Temperature	0°C to 60°C
Altitude	≤2,000 m
Humidity	20% to 90%, non-condensing

2.3 Safety Instructions

Please read the entire instruction manual before operating the Multi Platform Shaker.

⚠ WARNING DO NOT use the Multi Platform Shaker in a hazardous atmosphere or with hazardous materials for which the unit was not designed. Also, the user should be aware that the protection provided by the equipment may be impaired if accessories used are not provided or recommended by the manufacturer, or are used in a manner not specified by the manufacturer.

CAUTION ! To avoid electrical shock, completely cut off power to the unit by disconnecting the power cord from the unit or unplugging from the wall outlet. Disconnect unit from the power supply prior to maintenance and service. Any spills should be removed promptly. Bio hazard spills should be cleaned using approved liquid promptly. Solvent spills are a fire hazard. Stop the unit immediately, and **DO NOT** operate until clean up is complete and vapors have dissipated.

DO NOT immerse the unit for cleaning. **DO NOT** operate the unit if it shows signs of electrical or mechanical damage.

Placement of Loads

Please place loads symmetrically during operation.

Symmetrical placement

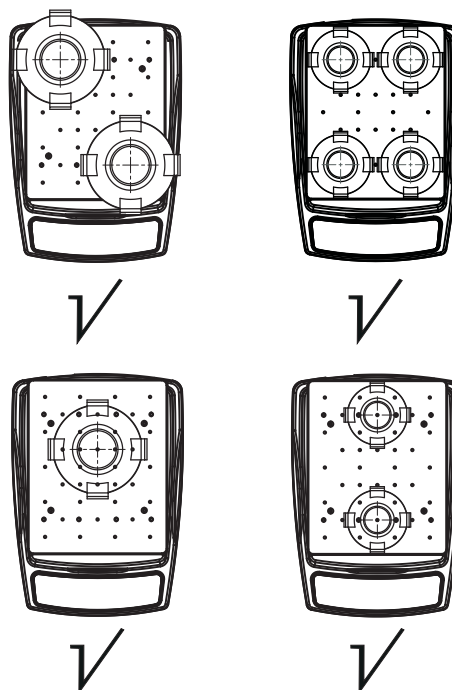

Asymmetrical Placement

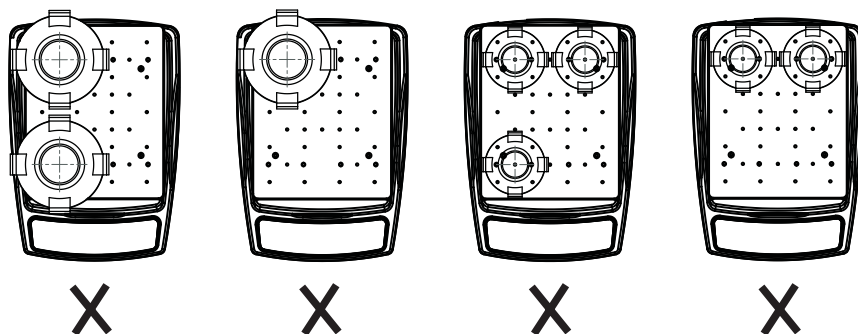

Warning: It may affect the normal operation of the instrument or even cause damage if placing loads asymmetrically.

2.4 Capacity and Speed

Conical Flask Size (ml)	≤Capacity (ml)	Max Speed(rpm)		
		With Flask Clamp	With Sticky Pad	With Nonslip Rubber Mat
50	5	450		160
	25			180
	50			210
100	10	450		170
	50	400		210
	100			230
150	15	450		170
	75	420		230
	150	400		240
200	20	450		160
	100	410		230
	200			240
250	25	450		160
	125	420		200
	250			210
500	50	450		230
	250	370	400	210
	500	360	380	230
1000	100	450		250
	500	330		210
	1000	320		230
2000	200	450		230
	1000	300		200
	2000	320		220
3000	300	450		230
	1500	330		180
	3000	290		200
5000	500	450		250
	2500	270		170
	3500			170

Note: Unit may have up to a +/- 5% RPM variability. The ultimate speed maybe different as the clamp is from different brand.

Section 3 Operation

This chapter covers the control panel and its operation.

3.1 Control Panel

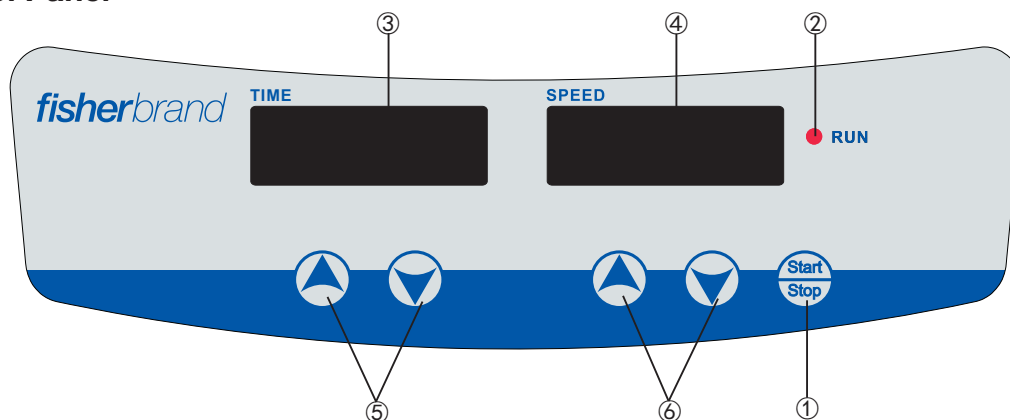

The front panel of the Multi-Purpose Tube Rotator contains all the controls needed to operate the unit.

1. Start/Stop button: Start or stop the instrument.
2. RUN indicator light: The light is on when the instrument is running and off when the instrument is in standby.
3. TIME display window: The window shows cumulative time (in continuous mode) or remaining time (in timer mode). The range of time displayed is 0 to 99 hours and 59 minutes. The accuracy is 1 minute.
4. SPEED display window: The window shows set speed (when the instrument is in standby) or current speed (when the instrument is running).
5. Set Time Buttons: UP/DOWN Arrow buttons are used to increase/decrease the set time of the instrument.
6. Set Speed Buttons: UP/DOWN Arrow buttons are used to increase/ decrease the set speed of the instrument.

3.2 Installation

1. Connect all the components according to the figures shown on page 4 of this manual. Use grounded power outlet.
2. Press down the power switch on the back right side of the instrument and put it to the “|” state and then the instrument is in standby.

3.3 Settings

Time Settings

1. Continuous mode

Press the “▲” or “▼” arrow button below the TIME display window. When the number shown on the display window starts flashing, press “▼” arrow button to decrease the time to 00:00 and then release the button. The time setting is finished after the number shown on the display window has flashed twice.

2. Timer mode

Press the “▲” or “▼” arrow button below the TIME display

window. When the number shown on the display window starts flashing, press “▲” or “▼” arrow button to increase or decrease the time value. Release the button when the time shown on the display window reaches the set value. The time setting is finished after the number shown on the display window has flashed twice.

Speed Settings

Press the “▲” or “▼” arrow button below the SPEED display window. When the number shown on the display window starts flashing, press “▲” or “▼” arrow button to increase or decrease the speed value. Release the button when the speed shown on the display window reaches the set value. The speed setting is finished after the number shown on the display window has flashed twice.

Note: press the “▲” or “▼” arrow button for a longer time to accelerate the setting.

Run and Stop

1. Continuous Mode

Press “Start/Stop” button and the instrument will start running with the specified settings and the RUN indicator light will be on. The TIME display window will show the cumulative time and the SPEED display window will show the current speed. Press “Start/Stop” button again and the instrument will slow down until it stops. The instrument will then be in standby and the two display windows will show the set values.

2. Timer Mode

Press “Start/Stop” button and the instrument will start running with the specified settings and the RUN indicator light will be on. The TIME display window will show the remaining time and the SPEED display window will show the current speed. Press “Start/Stop” button again and the instrument will slow down until it stops. The instrument will then be in standby and the two display windows will show the set values.

Finish Operation

After the operation is finished, press the power switch at the back right side the instrument and put it into the “O” state. Unplug the instrument and store the instrument according to the storage guide.

Note:

To ensure shaking operation smooth and steady, it may take minute for the microprocessor control system to accelerate the tray to the set speed.

Alarm Instructions

1. If the actual rotation speed is 0 or above 450 rpm when the instrument has been in normal operation mode for 10 seconds, the instrument will alarm immediately.
2. If the instrument is running steadily when the instrument has been in normal operation mode for 10 seconds, the instrument will alarm immediately. (Running steadily means the unit has been

running at the actual speed which is within ± 10 rpm of the set speed for 2 seconds.)

3. After the instrument alarms, LED RUN indicator light will go off, LED SPEED window will show “ERR1”, and the instrument will stop running. Press any button to put the instrument standby.

4. In timer mode, the instrument will stop running and the alarm will sound when the timer goes off.

Power Recovery

If the power supply is cut off suddenly while the instrument is in operation, the unit will automatically run at the previously set parameter upon power restoration. The display window will flash. Press any button to stop flashing.

Set Rotation Speed	Actual Rotation Speed	Alarm Time
(0, 100)	Lower 10 RPM than the set speed and no more than 50% of the set speed	After 10 seconds
	More than 10 RPM than the set speed and no more than 150% of the set speed	After 10 seconds
	Lower 10 RPM than the set speed and lower than 50% of the set speed	After 2 seconds
	More than 10 RPM than the set speed and more than 150% of the set speed	After 2 seconds
(100, 450)	Lower 10 RPM than the set speed and no more than 70% of the set speed	After 10 seconds
	More than 10 RPM than the set speed and no more than 130% of the set speed	After 10 seconds
	Lower 10 RPM than the set speed and lower than 70% of the set speed	After 2 seconds
	More than 10 RPM than the set speed and more than 130% of the set speed	After 2 seconds

3.4 Installation of Accessories

Installation of Tray

1. Remove platform as shown in the figure 1.
2. Align counter bores and nut columns, and fasten the screws as shown in the figure 2.
3. Place nonslip rubber mat onto the platform as shown in the figure 3.

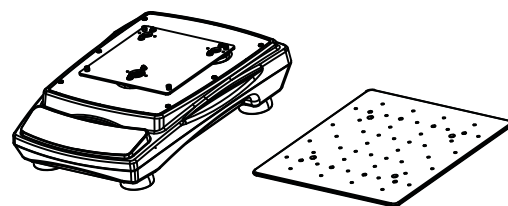

figure 1

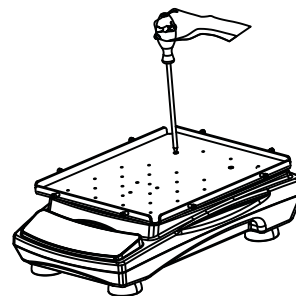

figure 2

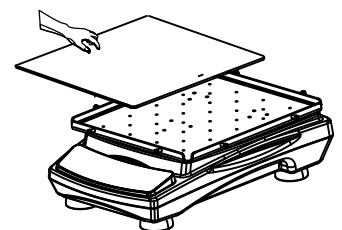

figure 3

Note: Nonslip rubber mat is only used for low-speed shaking. In order to prevent containers from moving during operation, it is recommended to use rubber bands to fasten the container.

Installation of Test Tube Rack

1. Place the test tube rack holder at the corresponding position on the aluminum platform and fasten the 4 sunk screws as shown in the figure 4.
2. Vertically clamp the tube rack into the tube rack holder and make sure the bottom of the tube rack is closely attached to the holder as shown in the figure 5.
3. Insert test tubes.

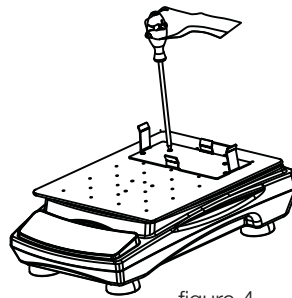

figure 4

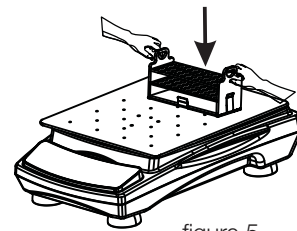

figure 5

Installation of Flask Clamp and Infusion Bottle Clamp

1. Fasten flask clamp and infusion bottle clamp onto the platform with screws as shown in the figure 6.
2. Put corresponding flask and infusion bottle into the clamp.

Note: To prevent splashing, containers should not be full of liquid during shaking. It is recommended to fill the container up to 2/3 of the maximum capacity.

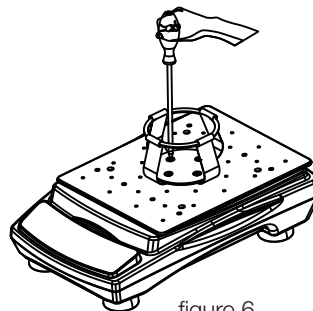

figure 6

Installation of Universal Platform with Adjustable Bars

1. Fasten Universal Platform with Adjustable Bars onto the platform as shown in the figure 7.
2. Place nonslip rubber mat onto the flat surface of Universal Platform with Adjustable Bars.
3. Install wheel and fixed handle. Do not fasten the screw to make sure the wheel can move back and forth along the waist-shaped long hole on Universal Platform with Adjustable Bars as shown in the figure 8.
4. Place conical flask between the wheels, adjust the position of the wheels to fasten the flasks, and tighten the fixed handle as shown in the figure 9.

Note: The rotation speed is inversely proportional to the load. When the instrument is used to shake test tubes, it is recommended to adjust the rotation speed from low to high step by step and run the machine at an appropriate speed.

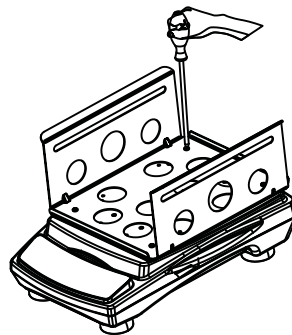

figure 7

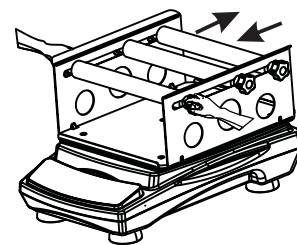

figure 8

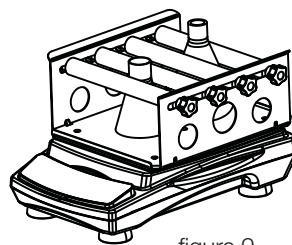

figure 9

Section 4 Safety Tips and Maintenance

Safety Tips

1. Use independent power supply.
2. Check if the local power supply voltage is suitable for use.
3. Do not drag the power supply cable when unplugging.
4. Do not use non-specified power cable or damage cable.
5. Service should only be performed by a qualified professional.
6. The power supply must be unplugged under the following situations:
 - a. When the unit is moved
 - b. When the electrical cabinet or the moving component is opened
 - c. When the equipment is malfunctioning
 - d. When the equipment is not in use

Maintenance

- a. This instrument uses brushless DC motor. It is maintenance free and has a long service time, high quality, and low noise level.
- b. Surface can be cleaned with a mild detergent and water.

Clean Spill

If accidental spillage of liquids caused by mishandling or contained breakage occurs on the surface of the instrument, please shut down the instrument and clean up the liquid immediately.

If the liquid has already spilled into the unit, cut off the power supply first and immediately clean up the liquid at the surface of the instrument. Place the instrument in a ventilated and dry environment for 24 hours before reuse. If the instrument is not functioning after drying for 24 hours, please contact the manufacturer.



Warning: Disassembling/Assembling without a qualified professional's guidance may cause malfunctioning of the instrument.



Section 5 Troubleshooting

Please refer to the following table to troubleshoot if any malfunction occurs. If the problem still exists, contact your local sales representative.

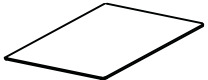
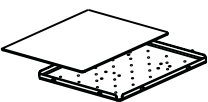
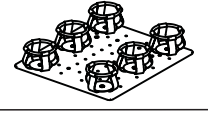
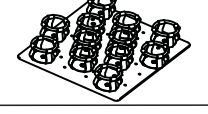
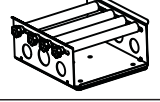
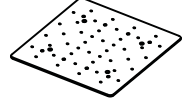
Error	Cause	Solution
Cannot start machine, LED display window off	Power disconnected	Connect the power
	Power switch off	Turn power switch on
	Power adaptor failure	Replace power adaptor
No shaking of the tray	Over-weighted or unbalanced load	Adjust the weight and position of load, decrease rotation speed
	Electrical malfunction	Contact Fisher Scientific
	Mechanical malfunction	Contact Fisher Scientific
Loud noise	Machine case loose	Fasten machine case screws
	Tray loose	Fasten tray screws
	Load moving	Fix load position
Other	Keep record for maintenance	

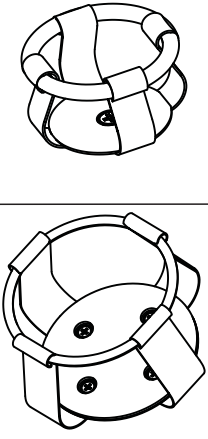
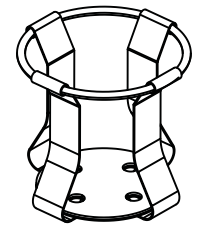
Section 6 Optional Accessories/Spare Parts

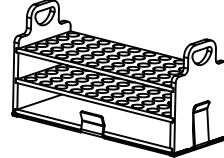
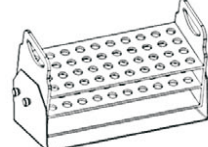
Description	NA Cat. No.	EU Cat. No.	Dimensions	Max. Qty	Figure
Nonslip Rubber Mat	N/A	15514100	306×246mm	1	
Flat Platform with Nonslip Rubber Mat	88861131	15524100	330×270×19mm	1	
Platform with Clamps for 6x250ml flasks	88861132	15534100	310×284×60mm	1	
Platform with Clamps for 12x100ml flasks	88861133	15544100	310×284×48mm	1	
Universal Platform with Adjustable Bars	88861134	15554100	307×303×145mm	1	
Universal (Aluminum) Platform	N/A	15534120	310×284mm	1	
96-well Microplate Holder	N/A	15544120	128×86×23mm	5	
25ml flask clamp	88861135	15564100	Φ 58×46mm	20	
50ml flask clamp	88861136	15574100	Φ 59×38mm	20	
100ml flask clamp	88861137	15584100	Φ 66×43mm	8	
250ml flask clamp	88861138	15594100	Φ 85×55mm	8	
500ml flask clamp	88861139	15504110	Φ 105×59mm	6	
1000ml flask clamp	88861140	15514110	Φ 130×77mm	4	
2000ml flask clamp	88861141	15524110	Φ 168×91mm	2	
3000ml flask clamp	88861142	15534110	Φ 194×109mm	2	
5000ml flask clamp	88861143	15544110	Φ 231×120mm	1	
Sticky Mat	88861144	15554110	140×140mm	4	
500ml Infusion Bottle Clamp	N/A	15564110	Φ 100×92.5mm	5	
1000ml Infusion Bottle Clamp	N/A	15574110	Φ 125×122.5mm	5	

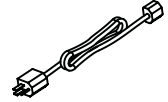
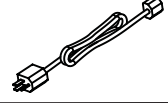
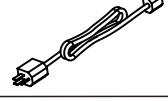
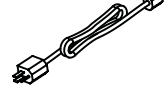
Description	NA Cat. No.	EU Cat. No.	Dimensions	Max. Qty	Figure
Funnel Clamp	88861147	15584110	90×90×150mm	2	
Fixed Tube Rack 40×Φ14	88861148	15594110	262×112×140mm	2	
Fixed Tube Rack 40×Φ16	88861149	15504120	262×112×140mm	2	
Fixed Tube Rack 40×Φ18	N/A	15783798	262×112×140mm	2	
Fixed Tube Rack 27×Φ22	N/A	15793798	262×112×140mm	2	
Fixed Tube Rack 21×Φ30	N/A	15703808	262×112×140mm	2	
Adjustable Tube Rack 40×Φ14	88861150	15514120	262×112×171mm	2	
Adjustable Tube Rack 40×Φ16	88861151	15524120	262×112×171mm	2	
Adjustable Tube Rack 40×Φ18	N/A	15713808	262×112×171mm	2	
Adjustable Tube Rack 27×Φ22	N/A	15723808	262×112×171mm	2	
Adjustable Tube Rack 21×Φ30	N/A	15733808	262×112×171mm	2	
General Power Adaptor (Spare Part)	88861154	15554120	AC100~240V, 50/60HZ	1	
Power Cable US Plug (Spare Part)	88861155	N/A	125VAC, 10A, 1.8m	1	
Power Cable CN Plug (Spare Part)	88861156	N/A	250VAC, 10A, 1.8m	1	
Power Cable EU Plug (Spare Part)	88861157	15564120	250VAC, 16A, 1.8m	1	
Power Cable Uk Plug (Spare Part)	88861158	15574120	250VAC, 13A, 1.8m	1	

Section 7 Warranty

When used in laboratory conditions and according to these operation instructions and maintenance, this product is warranted for 24 months against defective materials or workmanship. The 24 month warranty period begins from the delivery date of this product.

For product quality or performance issues, contact Fisher Scientific Customer Service.

North America

United States
1-800-766-7000
fishersci.com

Canada
1-800-234-7437
fishersci.ca

Europe

Austria:
+43(0)800-20 88 40
at.fishersci.com

Belgium:
+32(0)56 260 260
be.fishersci.com

Denmark:
+45 70 27 99 20
fishersci.dk

Germany:
+49(0)180 5258221
de.fishersci.com

Ireland:
+959(0)1 885 5854
ie.fishersci.com

Italy:
+39 02 950 59 478
it.fishersci.com

Finland:
+358(0)9 8027 6280
fishersci.fi

France:
+33(0)388 67 14 14
fishersci.fr

Netherlands:
+31(0)20 4887 70 00
nl.fishersci.com

Norway:
+47 22 95 59 59
fishersci.no

Portugal:
+351 21 425 33 50
pt.fishersci.com

Spain:
+34 002 239 303
es.fishersci.com

Sweden:
+46 31- 68 94 30
fishersci.se

Switzerland:
+41(0)56 618 41 11
ch.fishersci.com

UK:
+44(1)1509 555 500
fisher.co.uk

Find out more at **fishersci.com**