

OPERATOR'S MANUAL



DEAD AIR WORKSTATION

**AC600 Series Dead Air Box & Timed UV Light
with UVtect™ Controller**

AirClean® Systems
The Fume Control Experts.

3248 Lake Woodard Drive, Raleigh, NC 27604 USA
Phone: 919-255-3220 • Toll Free: 800-849-0472 • Fax: 919-255-6120
Website: www.aircleansystems.com • Email: info@aircleansystems.com

* Product designs are subject to change without notice.

© 2012 AirClean® Systems

CONTENTS

SECTION	PAGE
Warranty	3
Declaration of Conformity	4
Symbols and Definitions	5
Cautions and Precautions	6
Technical Specifications	7
Overview	8
Installation Instructions	9
Controller Instructions	11
Programming Menus	12
Operating Instructions	13
Alarm Messages	13
Maintenance:	
• Bulbs	14-16
• Cleaning	16
Spare Parts List	16
Options	17-18
Shipping Claims	19
Contact Information	19

FIGURES	PAGE
Figure 1, AC600DBC interior	8
Figure 2, Lifting the workstation properly	9
Figure 3, Swell latch locations	10
Figure 4, Linecord connections	10
Figure 5, Control panel layout	11
Figure 6, Fluorescent bulb replacement	14

WARRANTY

Warranty registration must be completed online.

To activate warranty visit:
aircleansystems.com/warranty

AirClean® Systems is committed to providing our customers with quality equipment and service after the sale. We request that you take a moment to fill out the warranty registration form at aircleansystems.com/warranty so that we may ensure prompt and efficient service in the future.

AirClean® Systems provides a warranty on all parts and factory workmanship. The warranty includes areas of defective material and workmanship, provided such defect results from normal and proper use of the equipment.

The warranty for all AirClean® Systems products will expire one year from date of shipment from AirClean® Systems, except for DrySafe™ and CyanoSafe™ product lines, which carry a two-year warranty from date of shipment.

This limited warranty covers parts and labor, but not transportation and insurance charges. In the event of a warranty claim, contact AirClean® Systems or the dealer who sold you the product. If the cause is determined to be a manufacturing fault, the dealer or AirClean® Systems will repair or replace all defective parts to restore the unit to operation. Under no circumstances shall AirClean® Systems be liable for indirect, consequential, or special damages of any kind. This statement may be altered by a specific published amendment. No individual has authorization to alter the provisions of this warranty policy or its amendments. Lamps and filters are not covered by this warranty. Damage due to accidental breakage is also not covered.

NOTE: Do not return any materials without authorization from AirClean® Systems. Products returned without prior authorization will not be accepted. AirClean® Systems and its dealers are not responsible for shipping damage. The recipient must file claims directly with the freight carrier. If authorization has been received to return this product, by accepting this approval, the user assumes all responsibility and liability for biological and chemical decontamination and cleansing. AirClean® Systems reserves the right to refuse delivery of any products which do not appear to have been properly cleaned and/or decontaminated prior to return. Please see additional Shipping Claims on Page 20.

IMPORTANT: Complete the warranty registration form at aircleansystems.com/warranty

AirClean® Systems

The Fume Control Experts.

DECLARATION OF CONFORMITY

We: AirClean® Systems, Inc.
of: 3248 Lake Woodard Drive
Raleigh, North Carolina 27604
USA

declare that:

Product Name: Ductless PCR Workstation
Model Numbers: AC632DBC and AC648DBC

in accordance with the following Directives:

73/23/EEC The Low Voltage Directive as amended by 93/68/EEC
89/336/EEC EMC Directive as amended by 92/31/EEC

has been designed and manufactured to the following specifications:

Safety: IEC 61010: 2001 SAFETY REQUIREMENTS FOR ELECTRICAL EQUIPMENT
FOR MEASUREMENT

EMC: CISPR 11 Electromagnetic Disturbance Characteristics - Limits And
Methods of Measurement
IEC 61000-4-2 Electromagnetic Compatibility, ESD
IEC 61000-4-3 Electromagnetic Compatibility, Radiated Immunity
IEC 61000-4-4 Electromagnetic Compatibility, Fast Transient
IEC 61000-4-5 Electromagnetic Compatibility, Surge
IEC 61000-4-6 Electromagnetic Compatibility, Conducted Immunity
IEC 61000-4-8 Electromagnetic Compatibility, MM
IEC 61000-4-11 Electromagnetic Compatibility, Voltage Interruption

The CE marking has been affixed on the device according to article 10 of the EMC Directive 89/336/EEC.







I hereby declare that the equipment named above has been designed to comply with the relevant sections of the above referenced specifications. The unit complies with the essential requirements of the directives.

Signed by: 

Name: M. Kevin McGough
Position: General Manager

Raleigh, North Carolina USA 15- Apr-2004

SYMBOLS THAT MAY APPEAR ON YOUR ENCLOSURE

	Alerts the user to the presence of dangerous voltages within the product's enclosure that maybe of sufficient magnitude to constitute a risk of electric shock to persons.
	Alerts the user to the presence of important operating maintenance or service instructions.
	Alerts the user to the possible presence of ultraviolet light.
	Alerts the user that two persons are required for safe lifting of the object.
	The presence of this symbol means that this equipment has been designed, tested and certified as complying with the applicable Underwriter's Laboratory (USA) regulations and recommendations.
	The presence of this symbol means that this equipment has been designed, tested and certified as complying with all of the essential requirements applicable to European Union (CE) regulations and recommendations.
	This symbol alerts the user to the correct replacement fuses for the product.

Abbreviation Definition

PPE	Personal Protective Equipment
OSHA	Occupational Safety and Health Administration
ACGIH	American Conference of Government Industrial Hygienists
TLV	Threshold Limit Value
UV	Ultraviolet
MSDS	Material Safety Data Sheet

CAUTIONS AND PRECAUTIONS

Notices in this Manual



WARNING

Indicates a potentially hazardous situation, which if not avoided, could result in death or serious injury.



CAUTION

Indicates a potentially hazardous situation, which if not avoided, may result in minor or moderate injury. It may also be used to alert against unsafe practices or potential equipment damage.

General Cautions



Always use a properly grounded line cord and receptacle.



Always replace fuses with those specified.



These instructions must be placed in an easily seen location.



DO NOT use this equipment for purposes other than nucleic acid preparation and amplification of non-biological substances.



DO NOT use this system until it has been properly installed.



DO NOT operate this unit if the linecord appears damaged or frayed in any way.



DO NOT attempt to access non-user serviceable components of system.



DO NOT operate this unit if display is blank or hard to read. If display is hard to read, call customer service.



DO NOT look directly at the UV light.

TECHNICAL SPECIFICATIONS

SPECIFICATIONS	AC632DBC	AC648DBC
Physical Dimensions		
Outside Dimensions	32"w x 30"h x 24"d	48"w x 32"h x 24"d
Inside Dimensions	31"w x 18"h x 23"d	47"w x 19"h x 23"d
Weight	100 lbs.	150 lbs.
Electrical		
Voltage	110VAC 60 Hz or 230VAC 50 Hz	110VAC 60 Hz or 230VAC 50 Hz
Current	1.4A / .7A	2.8A / 1.4A
Power Consumption	150W	300W
Mains Fluctuation	±10%	±10%
Fuses		
Type	3A 250V, Slow Blow 5 X 20	6.3A 250V, Slow Blow 5 X 20
Requirements	1 (110V) / 2 (230V)	1 (110V) / 2 (230V)
Environmental		
Usage	Indoor Use Only	Indoor Use Only
Altitude	Up to 2000m	Up to 2000m
Humidity	80% Max up to 31C Decreasing Linearly to 50% at 40C	80% Max up to 31C Decreasing Linearly to 50% at 40C
Installation Category	II	II
Pollution Degree	2	2
Construction		
Top Material	ABS	ABS
Front Panel and Sides (3)	Lexan™ Polycarbonate	Lexan™ Polycarbonate
Base Material	Structural Polypropylene	Structural Polypropylene
Options		
Cart w/ two 4" locking wheels	32"l x 24"w x 34"h	48"l x 24"w x 34"h

OVERVIEW

The AC600 Series DBC Workstation, with UVText™ microprocessor-driven controller provides 254 nm short-wave UV light to effectively irradiate contaminating DNA and RNA within minutes. Short-wave UV bulbs (254 nm) have a definable useful life of 1000 hours in your workstation. The UVText™ Controller tracks UV bulb hours and alerts the user when to replace the UV bulb. The overlapping sash design prevents operator exposure to shortwave UV energy.



THIS WORKSTATION IS NOT DESIGNED FOR USE WITH BIOLOGICAL SAMPLES.

HOW THE AC600DBC WORKSTATION WORKS:

1. UV light sterilizes pipette tips, tubes and flasks.

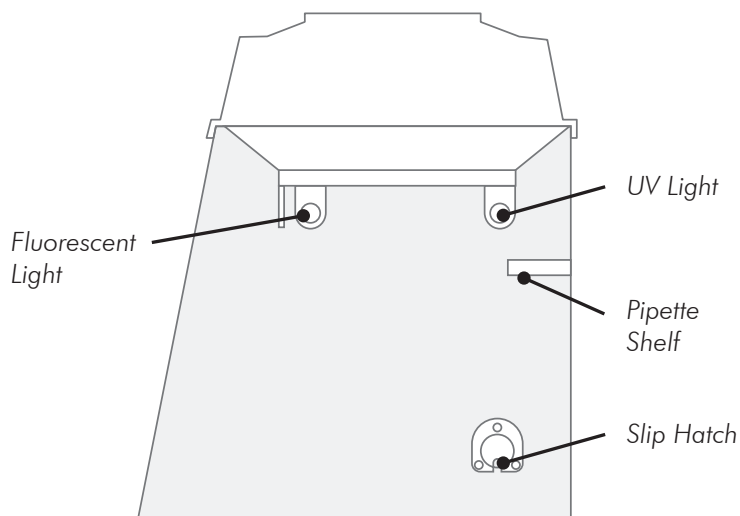

Figure 1, AC600DBC interior

INSTALLATION INSTRUCTIONS



DO NOT lift the workstation by the head assembly, the sash, or any protruding wires.

- 1) If ordered, assemble the mobile cart. Assembly instructions are included with the cart and also in the OPTIONS section of this manual. (Page 20)
- 2) Designate the appropriate installation location. Make sure that the desired area is stable enough to hold the workstation and that there is an appropriate AC wall receptacle near the workstation. Do not place workstations near doors or windows.
- 3) With the help of a co-worker, lift the workstation out of the bottom tray of the box. Make sure to lift from the bottom of the workstation. See figure 2.

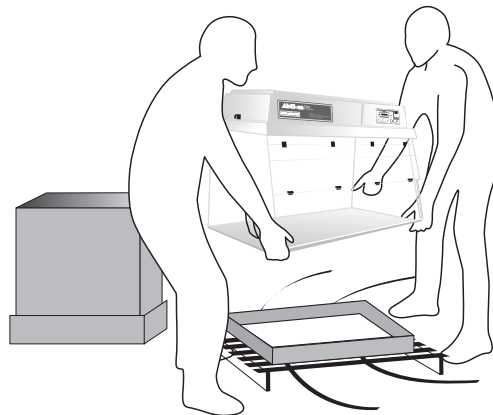

Figure 2, Lifting the workstation properly

- 4) Place the workstation in the desired location. Once in place, make sure that it is secure and stable.
- 5) Visually inspect your workstation, checking for any damage that may have occurred in shipping. Pay special attention to the sash hinges. If damage has occurred, call AirClean® Systems immediately. DO NOT attempt to use workstation.
- 7) Make sure that the swell latches, located on the side lip of the head assembly, are in the latched (down) position and that the head assembly is secure and properly seated. See figure 3. (Page 10)

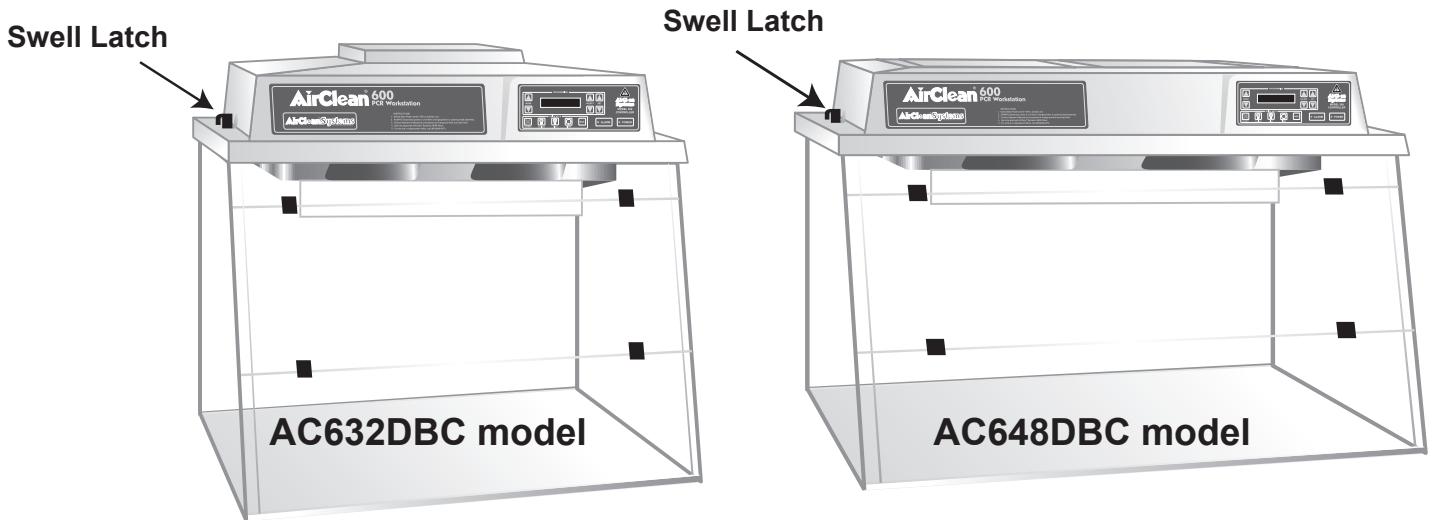



Figure 3, Swell latch locations.

- 8) Ensure that the door switch cable on the right hand side of the head assembly is secure. See figure 4.

 CAUTION	<p><i>Only use approved accessories with the exterior connectors.</i></p>
--	--

- 9) Make sure that any exterior linecord connections are secure and seated properly. These connections are located on the back of the workstation. See figure 4.
- 10) Locate the power entry module on the back of the workstation. Insert the female end of the linecord into the power entry module and the male end into an appropriate electrical outlet. See figure 4.

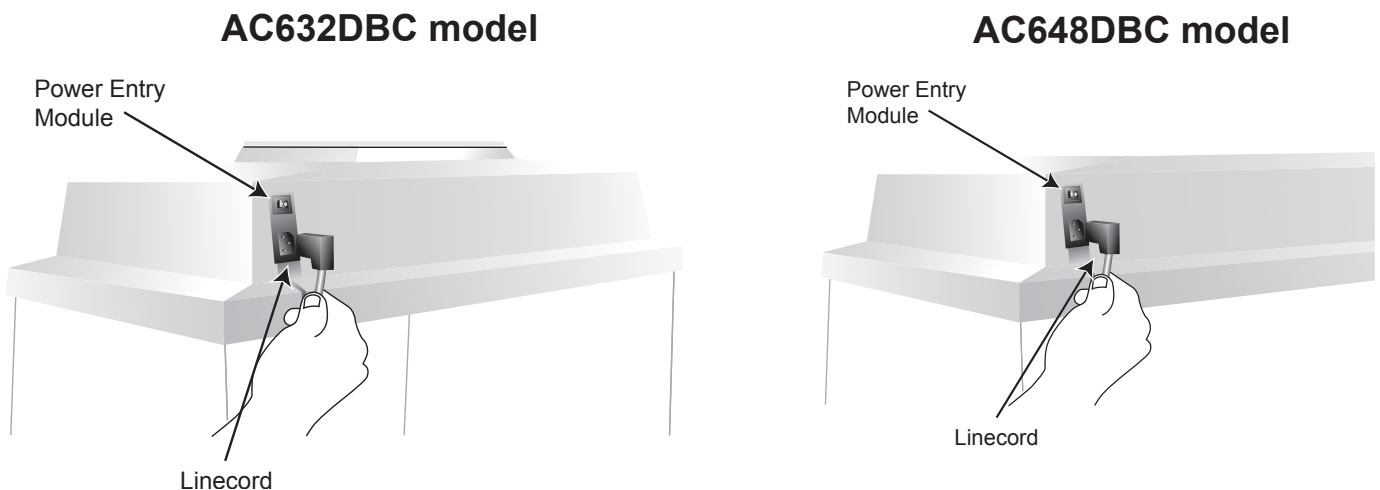

Figure 4, Linecord Connections.

CONTROLLER INSTRUCTIONS

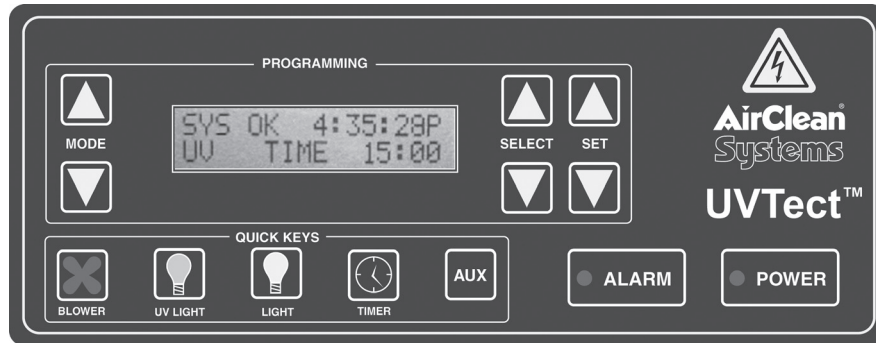





Figure 5, Control panel layout.

QUICK KEYS	
	UV LIGHT (light blue icon) - One touch to enable UV light bulb. When front sash is opened, safety switch automatically turns UV light off to prevent exposure. Front sash must be closed for UV light to illuminate.
	LIGHT (yellow icon) - Inactive key for workstation. (Light will automatically turn on when front sash is opened and turn off when sash is closed.)
	TIMER - User definable lab event timer.
	AUX - Inactive key for workstation.
NAVIGATION KEYS	
MODE	Allows the operator to move between different program screens.
SELECT	Allows movement within each program screen. The user modifiable portions of the screen will be blinking.
SET	Allows operator to adjust the following user definable settings: <ul style="list-style-type: none"> • Lab event timer • UV light timer • Time/Date

* All other settings are factory pre-set and should not be changed.

PROGRAMMING MENUS

NOTE: The UVtect™ controller has been pre-programmed by AirClean® Systems to allow the unit to be operational immediately. (The fluorescent light, which is preset to run at full speed, automatically turn on when sash is opened.) The UV light time is preset to stay on for a 15-minute period when the sash is closed and the UV key is depressed.

- **MAIN MENU** - Displays the time, date, and status when the main power is on and the controller power is off. When controller power is activated the screen will display one of the following and may be changed by pressing the “Select” arrow keys:
- **UV Timer** - UV light timer, factory set at 15 minutes.
- **Timer** - General lab event timer, factory set at 20 minutes.

Press “Mode” arrow keys to scroll between the following program screens:

TIMER - Allows operator to turn the lab event timer on/off and set a specific amount of time. Pressing the “Timer” quick key on the controller will activate the timer.

UV - Allows operator to set operation time of UV light. It is factory preset for 15 minutes.

TIME/DATE - Operator can change displayed time and date.

ALARM ENABLE - THIS SCREEN IS FACTORY PRESET. DO NOT ALTER THIS SCREEN!
Controls audio/visual alarms for workstation.

NOTE: You can deactivate the audible alarm, when it sounds, by touching the alarm button on the controller. The visual alarm will still work.

UV LAMP - Displays hours remaining for UV bulb life.

NOTE: Each time the UV bulb is illuminated, a minimum of one hour will be used. Each UV bulb has a life expectancy of 1000 bulb hours. The workstation will alarm before the bulb life expires. For complete instructions on replacing the UV bulb, refer to the Maintenance Section on Page 17.

ADDITIONAL INFORMATION

- Changes within each program are automatically saved.
- After programming the above options, use the quick keys to activate/deactivate the features.

OPERATING INSTRUCTIONS

- 1) To activate the main power of the workstation, flip the switch above the power inlet. See figure 5.
- 2) On the controller, the green light on the POWER quick key should be illuminated. If it is not, press the POWER quick key once to turn on the system. While the system is on, the top line of the controller screen will read "SYS OK" and display the time. The bottom line of the controller will read one of the following, and can be changed by pressing the SELECT arrow keys:
 - Timer - General lab event timer
 - UV Time - UV light timer, factory set at 15 minutes*To change settings, see Controller Instructions on page 11.*
- 3) Open the front sash. The fluorescent light should turn on. When sash is closed, the fluorescent light should turn off.
- 4) To begin the sterilization period, close the sash completely and press the UV light quick key on the controller. The UV light timer will count down from 15 minutes. The UV light will automatically turn off when the timer reaches zero.

Note: The UV light will automatically turn off when the front sash is opened and will activate when the sash is closed. The UV light timer will continue counting down once the sash is closed.

- 5) Always close the front sash when the workstation is not in use and press the "POWER" button on the controller to turn off the unit. The LCD screen will display the time and date.
- 6) Clean the unit on a scheduled basis. See MAINTENANCE section for instructions. (page 18)

ALARM MESSAGES

The alarms that are built into the system are maintenance related. They are designed to tell the operator about conditions that may affect the operation of the workstation and decrease its performance.

- **ALARM → UV CHECK** - The UV light alarm occurs after 900 use-hours of the UV bulb. (One use-hour = an hour of actual use or one on/off cycle of the light.) After 1000 use-hours, the UV bulb may glow blue but the UV radiation may not be effective. Replacement of the UV bulb is required.

BULBS

Fluorescent Bulb Replacement

The AC632DBC workstation contains one fluorescent bulb, and the AC648DBC workstation contains two fluorescent bulbs. They may be replaced as needed with a 15W Cool White Bulb.

To replace the fluorescent light bulb in the AC632 model:

 <p>CAUTION</p>	<p><i>Disconnect the linecord from the power entry module prior to proceeding.</i></p>
---	---

1. Turn off power at the power entry module. Disconnect linecord from the power entry module. See figure 4. (Page 10)
2. Completely open the folding front sash by carefully resting it on the head assembly of the workstation.
3. Using both hands, turn the bulb counter clockwise $\frac{1}{4}$ turn and remove from the light socket. See figure 7.
4. Install new bulb by sliding into the light socket and turning clockwise $\frac{1}{4}$ turn until the bulb locks into place.
5. Reconnect linecord to power entry module. Turn the power on at the power entry module. See figure 4. (Page 10)

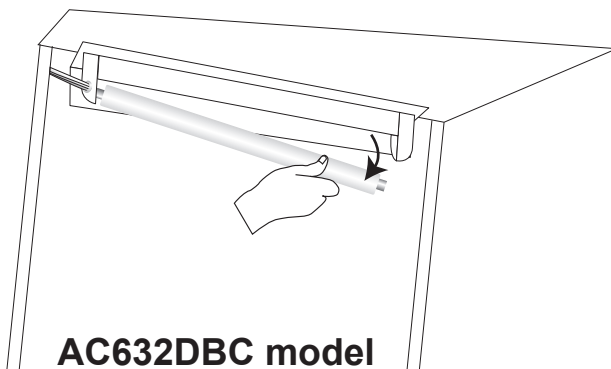

Figure 7, Fluorescent bulb replacement.

To replace the fluorescent light bulb in the AC648DBC model:



1. Disconnect linecord from the power entry module. Disconnect the door switch cable and light cables. See figure 4. (Page 10)
2. Using both hands, turn the bulb counter clockwise $\frac{1}{4}$ turn and remove the bulb from the socket.
3. Install new bulb by sliding into the light socket and turning it clockwise $\frac{1}{4}$ turn until the bulb locks into place.
4. Reconnect the linecord, door switch cable, and light cables.

UV Bulb Replacement

Each UV bulb has a life expectancy of 1000 bulb hours. The UVtect™ Controller will track the remaining UV bulb hours. Each time the UV bulb is illuminated, a minimum of one hour will be used. The alarm will sound when 100 UV bulb hours remain. When the life of the UV bulb has expired, the UV light will not work until a new bulb is installed.



To replace the UV light bulb(s) in the AC632DBC or AC648DBC models:

1. Turn off power at the power entry module. Disconnect linecord from the power entry module. See figure 4. (Page 10)
2. Completely open the folding front sash by carefully resting it on the head assembly of the workstation.
3. Using both hands, turn the bulb counter clockwise $\frac{1}{4}$ turn and remove from the light socket.
4. Take note of the serial number on the sleeve of the new bulb prior to installing. Install new bulb by sliding into the light socket and turning clockwise $\frac{1}{4}$ turn until the bulb locks
5. Reconnect linecord to power entry module. Turn the power on at the power entry module. See figure 4. (Page 10)

To enter validation number of new UV bulb:

1. Press the “MODE” arrow keys until the UV Lamp screen is displayed. This screen will display the number of remaining useful hours for the UV bulb.
2. Press the “SELECT” up arrow key.
3. Using the “SET” keys, enter the new UV bulb validation number starting with the first digit. Press the “SELECT” up arrow key to move to the next digit.
4. Repeat until the entire validation number is entered.
5. Press the “SELECT” up arrow key until the “<” caret blinks.
6. Finish by pressing the “SET” up arrow key once to store the UV bulb validation number.

CLEANING

Exterior:

- Clean with only a soft, damp cotton cloth or an acrylic cleaner.
- *Do not use paper products to clean unit, as they may scratch the material.*

Interior:

- A high level disinfectant or 10% bleach/water solution may be used as needed. Sporidicin® is an approved disinfectant for use with AirClean® Systems PCR workstations.

 WARNING	<p><i>Interior cleaning with an approved disinfectant should be completed routinely. Residual moisture must be removed or UV radiation may cause chemical burn of the polycarbonate. If this occurs contact AirClean® Systems technical support before continued usage of product.</i></p>
---	--

SPARE PARTS LIST

CATALOG NO.	DESCRIPTION	AC632	AC648
77-52398	Electronics Box (648)	N/A	1
11-52757	Controller Touch Pad	1	1
10-50055	Power Inlet Fuse, 3.15 A, Slow Blow	1	N/A
10-50428	Power Inlet Fuse, 6.3 A, Slow Blow	N/A	1
03-50184	IEC Connector	1	1
77-52411	Door Switch	1	1
77-52441	Light Fixture	2	4
01-52053	Power Cord	1	1
09-50031	¼-20 x 1 PH bolt for fixed sash	4	4
09-50547	¼-20 Lock nut	4	4
06-50318	Sash Hinges	4	8
77-52431	Polycarbonate Front Sash, Complete	1	N/A
77-52407	Polycarbonate Front Sash, Complete	N/A	1
77-53715	Polycarbonate shell	1	N/A
77-52409	Polycarbonate shell	N/A	1
73-63281	Polypropylene Base	1	N/A
73-64887	Polypropylene Base	N/A	1
04-50647	Polycarbonate Sash Rails	2	2
10-50215	15W Cool White Fluorescent Lamp	1	2
ACAUVBL4	UV Bulbs, Pack of 4	1	2

Product designs are subject to change without notice, contact Customer Service before placing order.

OPTIONS

AIRCLEAN® SYSTEMS CART ASSEMBLY INSTRUCTIONS

Model ACA1011 and ACA1039

Your AirClean® Systems Cart is shipped with the following components:

- | | |
|--|---------------------------------------|
| 4 - Cross pieces | 8 - 1¼" washers (cross piece washers) |
| 2 - End pieces | 4 - Casters |
| 8 - Hook & Loop Fasteners (4 Hook, 4 Loop) | |
| 8 - 2" x ¼" Phillips head bolts
(cross piece bolts) | |

ASSEMBLY OF CART

1. Locate a cart end piece and one cart cross piece. Place one ³/₈" washer on to a 2" phillips head bolt.
2. Starting with hole one on the cart end piece place washer and bolt through the hole and into the threaded receiver of the cart cross piece. Hand-tighten only until cart is completely assembled.
3. Repeat steps above for holes 2 and 3.
4. For standard setup complete assembly using hole 4. For seated use complete assembly using hole 5.
5. Tighten all bolts completely.
6. Installation of casters should be per illustration on page 21.

MOUNTING OF ENCLOSURE TO ASSEMBLED CART

1. Remove the adhesive backing from one hook-side fastener and adhere to the top of the cart end piece, one inch from the front.
2. Repeat step one, adhering the fastener one inch from the back.
3. Repeat steps one and two for the other cart end piece. There should be strips of hook-side fasteners on all four corners of the top of the cart (see cart components diagram).
4. Attach loop-side fasteners to the hook-side fasteners and peel off the backing so the adhesive is exposed on all four corners.
5. Carefully place the enclosure on the assembled cart, lining up the enclosure and cart edges.
6. Firmly push down on the edges of the base inside the workstation so the adhesive sticks to the enclosure base.

CART COMPONENTS



Hook



Loop

Hook & Loop Fasteners

4 - Hook

4 - Loop

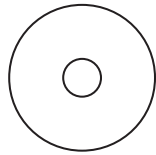

8 - 1 1/4" Washer

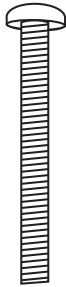

8 - 2" x 1/4" Bolt



4 - Cart Cross Piece

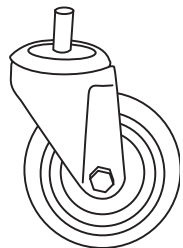

2 - Standard Caster

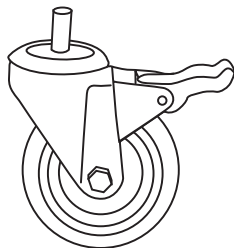

2 - Locking Caster

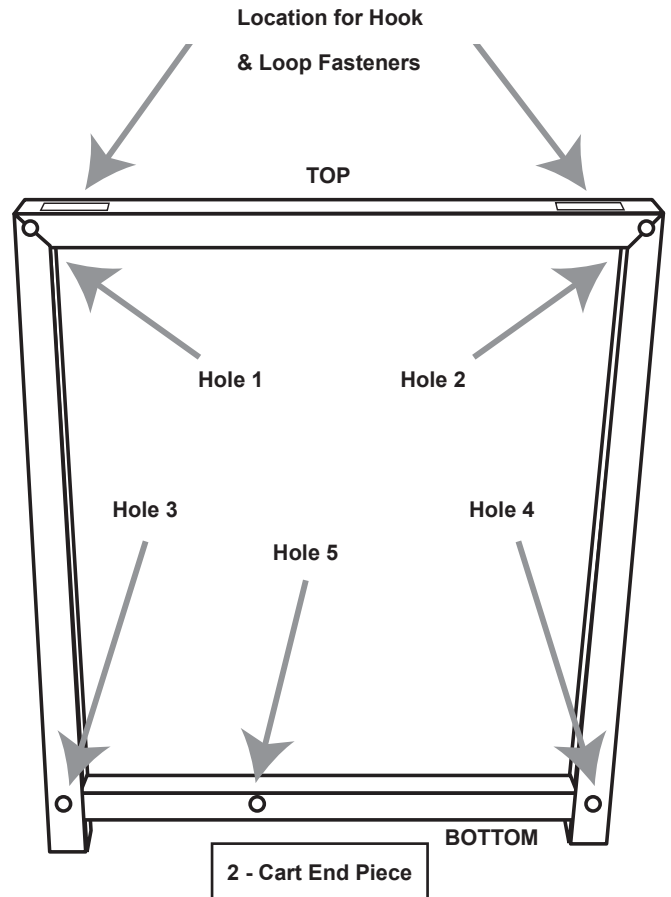

ASSEMBLED CART CONFIGURATIONS

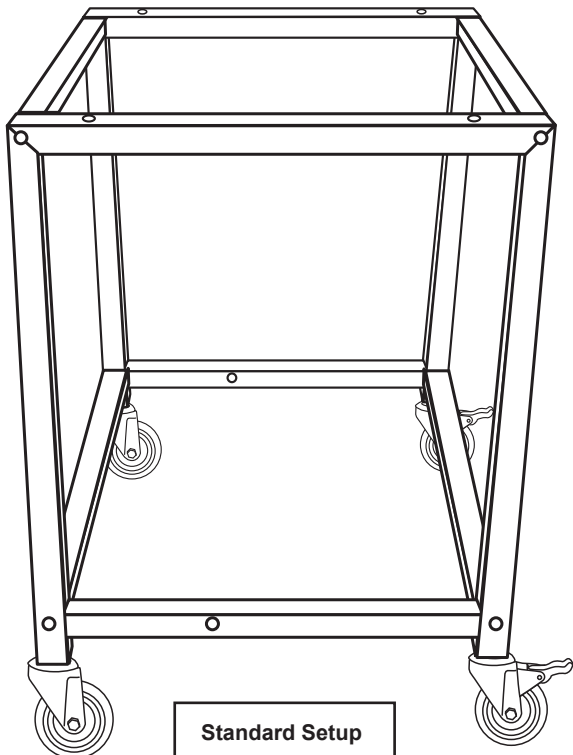

Standard Setup

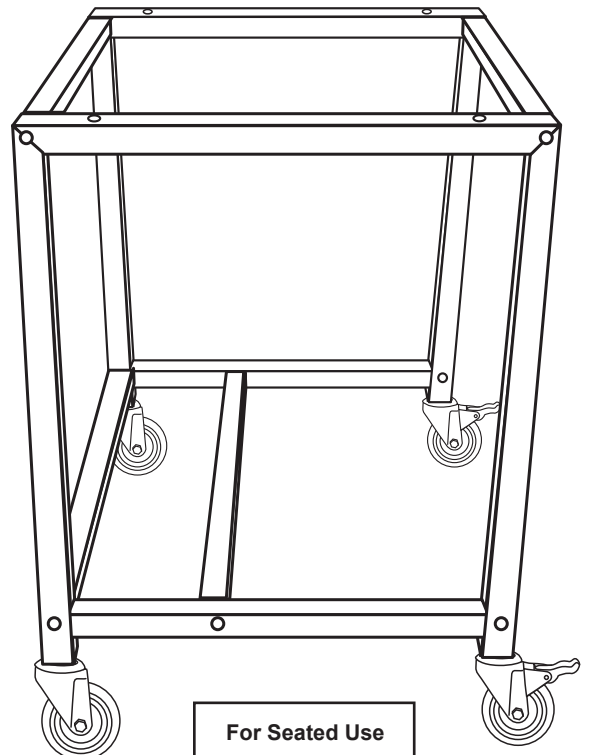

For Seated Use

SHIPPING CLAIMS

If a shipment is received with visible damage, be certain to make a notation on the delivering carrier's receipt and have their agent confirm the damage on your receipt. Otherwise, the damage claim may be refused.

If concealed damage or pilferage is discovered, notify the carrier immediately and retain the entire shipment intact for inspection. Interstate Commerce Commission rules require that the claim be filed with the carrier within 15 days of delivery.

NOTE: Do not return any materials without authorization from AirClean® Systems. Products returned without prior authorization will not be accepted. AirClean® Systems and its dealers are not responsible for shipping damage. The recipient must file claims directly with the freight carrier. If authorization has been received to return this product, by accepting this approval, the user assumes all responsibility and liability for biological and chemical decontamination and cleansing. AirClean® Systems reserves the right to refuse delivery of any products which do not appear to have been properly cleaned and/or decontaminated prior to return.

CONTACT INFORMATION

If you have any questions that are not addressed in this manual, or if you need technical assistance, please contact AirClean® Systems at 800-849-0472, between the hours of 8:00 AM and 5:30 PM EST.

AirClean® Systems mailing address:

AirClean® Systems
3248 Lake Woodard Drive
Raleigh, NC 27604

Phone: 919-255-3220 Toll Free: 800-849-0472 Fax: 919-255-6120

Visit AirClean® Systems on the Internet at: <http://www.aircleansystems.com>

Email AirClean® Systems at: info@aircleansystems.com

MODEL NO.

- AC632DBC**
- AC648DBC**

SERIAL NO.

AC632-DBC _____

AC648-DBC _____

AirClean[®] Systems

The Fume Control Experts.

3248 Lake Woodard Drive, Raleigh, NC 27604

Phone: 919-255-3220 Toll Free: 800-849-0472 Fax: 919-255-6120

Website: www.aircleansystems.com • Email: info@aircleansystems.com