



PRODUCT CATALOGUE
2012



Our new website...



Contents

Small Wet/Dry Pumps	1
Turbomolecular Pumps	2
Vapour Pumps	3
Measurement & Control	4
Vacuum Valves	5
Fittings and Flanges	6
Semiconductor Pumps	7
Industrial Pumps and Pumping Systems	8
Chemical Dry Pumps	9
Liquid Ring Pumps	10
Shelf Dryers	11
Process Vacuum	12
Service	13



Small Pumps and Pumping Systems	2
Small Pumps: Application and Accessory Information	3
Small Pumps and Accessories: Frequently Asked Questions	4
nXDS Scroll Pumps	5
nXDS-C Scroll Pumps	13
XDS Scroll Pumps	14
NGB Scroll Pumps	20
E2M0.7 and 1.5 Oil Sealed Rotary Vane Pumps	21
RV Rotary Vane Pumps	25
EM18 and 28 Oil Sealed Rotary Vane Pumps	33
Small ATEX Certified Pumps	37
Electrical Data	41
Diaphragm Pumps	46

Small Pumps and Pumping Systems

1

Page
2

To meet the diverse needs of applications ranging from analytical instrumentation, wet chemistry, R & D to light industrial, Edwards offers a comprehensive range of different pumping technologies. Refer to the application and accessory guide to select pumps and accessories for your application.

Oil Free Scroll Pumps

Scroll pumps are an excellent alternative to rotary vane pumps where oil free pumping is desirable. The innovative XDS pumps in particular use a bearing shield to isolate the vacuum environment from all forms of lubricant not only making them *totally dry*, but also protecting the bearing from any process gases. Vapour handling is enabled by an gas ballast; this allows the range of pumps to satisfy many applications that were previously off limits to scroll pumps.

- $\leq 2 \times 10^{-2}$ mbar / $\leq 1.5 \times 10^{-2}$ Torr
- 5 to 35 m³h⁻¹ / 2.9 to 20.6 ft³min⁻¹



Oil Sealed Rotary Vane Pumps



- $\leq 10^{-3}$ mbar / $\leq 10^{-3}$ Torr
- 0.9 to 32.3 m³h⁻¹ / 0.5 to 19.5 ft³min⁻¹

This wide range of rugged pumps offers an excellent ultimate with good pumping speed. RV pumps have superior vapour handling capabilities, while operating quietly.

Oil Free Diaphragm Pumps

- ≤ 2 mbar / ≤ 1.5 Torr
- 0.6 to 2.0 m³h⁻¹ / 0.35 to 1.2 ft³min⁻¹

The D-LAB diaphragm pumps are made of corrosion resistant materials, to withstand attack from chemicals. They are ideal for applications such as gel drying and other wet chemistry processes. The XDD1 diaphragm pumps provide oil free backing for compound turbomolecular pumps.

Easy to Service

All Edwards pumps are designed for easy routine maintenance. Key components are easily accessible and, with RV and XDS pumps, no special tools are required. Service kits of guaranteed parts are available for routine service by the user. Worldwide support from the Edwards service organization is also available.

Quality Manufacture

Edwards pumps are manufactured on state of the art machine tools for high consistency of components. For example, RV rotors are manufactured in a robotic cell to remove errors and inconsistencies from the manufacturing process.



Applications

Edwards high performance pumps are used in many industrial and laboratory applications, including the following:

- Electron microscopes, mass spectrometry, residual gas analysers and surface analysis
- Epoxy degassing, powder materials processing
- Solvent concentration
- Sterilization, distillation and centrifuges
- Gel dryers and glove boxes
- Atomic emission spectrometers, nuclear physics, fusion technology and space research
- Vacuum ovens
- TV tube evacuation
- Automotive system filling
- Freeze drying
- Vacuum metallurgy

Small Pumps: Application and Accessory Information

Use the information in the list below to select the best pump and accessories for your application. The information is given as a guide only; the optimum set-up may depend on your specific method of operation. Note that you need to buy the accessories separately, unless otherwise stated.

ATEX and Flammable Gases

The following standard pump models have an **internal** ATEX classification of  II 3 G c IIB T4:

- E2M0.7, E2M1.5
- E1M18, E2M18 & E2M28
- RV3, RV5, RV8, RV12
- XDS5, XDS10, XDS35i

The following standard pump models operating on hydrocarbon oil can be supplied with flameproof motors providing an **external** classification of  II 2 G IIB T4 (or IIC):

- RV3, RV5, RV8, RV12
- E1M18, E2M18



Gel Dryers

Recommended pump: nXDS/XDS or D-Lab.

Suggested accessories for D-Lab: Separator.

Optional accessories for D-Lab: Condenser, gas ballast valve.

Rotary Evaporation and Vacuum Ovens

Recommended pump: nXDS/XDS or D-Lab.

Suggested accessories for D-Lab: Separator.

Optional accessories for D-Lab: Condenser, gas ballast valve.

Centrifugal Concentration

Recommended pump: nXDS/XDS.

Vacuum Filtration

Recommended pump: nXDS/XDS or D-Lab.

Suggested accessories for D-Lab: Separator.

Optional accessories for D-Lab: Condenser, gas ballast valve.

Distillation/Extraction Apparatus

Recommended pump: nXDS/XDS or D-Lab.

Suggested accessories for D-Lab: Separator.

Optional accessories for D-LAB: Condenser, gas ballast valve.

Freeze Dryers

Recommended pump: nXDS/XDS or Rotary pumps.

Suggested accessories: Mist filters, oil return.

MS Inlet Systems (like Electro-Spray)

Recommended pump: XDS35i or E2M28.

Suggested accessories for rotary pumps: Mist filter, oil return.

Suggested accessories for nXDS/XDS: Silencer.

Load Locks, Fume Hoods and Glove Boxes

Recommended pump: nXDS/XDS or Rotary pumps.

Suggested accessories for rotary pumps: Mist filter, oil return.

Suggested accessories for nXDS/XDS: Silencer.

Ultra High Speed Centrifuges

Recommended pump: nXDS/XDS or Rotary pumps.

Suggested accessories: Mist filter

Suggested accessories for rotary pumps: Mist filters, oil return.

Leak Detection, Electron Microscopes, Mass Spectrometers and Lasers

Recommended pump: nXDS/XDS or Rotary pumps.

Suggested accessories for rotary pumps: FL20K, Mist filter.

Suggested accessories for nXDS/XDS: Silencer.

Surface Science and Particle Size Analysers

Recommended pump: nXDS/XDS or Rotary pumps.

Suggested accessories for rotary pumps: FL20K, Mist filter.

Suggested accessories for nXDS/XDS: Silencer.

High Energy Physics

Recommended pump: nXDS/XDS or Rotary pumps.

Suggested accessories for rotary pumps: FL20K, Mist filter.

Suggested accessories for nXDS/XDS: Silencer.

Helium or Rare Gas Recirculation

Recommended pumps: nXDS/XDS

Backing Turbomolecular Pumps

Recommended pump: nXDS/XDS, XDD1 or Rotary pumps.

Suggested accessories for rotary pumps: FL20K, Mist filter.

Suggested accessories for nXDS/XDS: Silencer.

Backing Diffusion Pumps

Recommended pump: nXDS/XDS or Rotary pumps.

Suggested accessories for rotary pumps: FL20K, Mist filter.

Suggested accessories for nXDS/XDS: Silencer.

Refrigeration, Air Conditioning Systems

Recommended pump: nXDS/XDS or Rotary pumps.

Suggested accessories for rotary pumps: FL20K, Mist filter.

Suggested accessories for nXDS/XDS: Silencer.

Vacuum Furnace

Recommended pump: nXDS/XDS or Rotary pumps.

Suggested accessories for rotary pumps: ITF20K, Mist filter.

Suggested accessories for nXDS/XDS: Silencer.

Azide Forming Applications

Recommended pump: nXDS/XDS or Rotary pumps.

Suggested accessories for rotary pumps: Mist filter.

Suggested accessories for nXDS/XDS: Silencer.

Notes

- FL20K is an inlet trap, to prevent oil back-streaming.
- ITF20K is an inlet trap, to capture dust particles.
- The gas ballast facility allows atmospheric air into the pump, minimising the formation of condensates (which contaminate the oil in rotary pumps).
- An oil return kit is available for E2M0.7, E2M1.5, RV, EM18 and E2M28 pumps to allow oil to be returned from the mist filter to the pump. A gas ballast oil return is also available to allow oil to return and have gas ballast flow.

Small Pumps and Accessories: Frequently Asked Questions

1

Page
4

Oil Mist

Question: What accessory do I use to trap oil mist (which all oil sealed pumps emit during pump down or with gas ballast)?

Answer: To meet regulations and preserve pump oil, fit a recommended Edwards oil mist filter (EMF) to the pump outlet, and connect the exhaust to an exhaust line.

Question: If I operate an RV pump continuously or with high inlet pressure, what accessories do I need?

Answer: Fit an Edwards mist filter (EMF) and a gas ballast oil return (GBOR) kit. Then the pump can be operated with the mode switch open and gas ballast oil return. The oil condensed in the filter will be continuously returned to the pump oil box.

Vapour Processes

Question: Which pump and accessories should I use if my process generates vapours which could condense in the pump?

Answer: You can choose either an nXDS/XDS pump, or rotary pump. Gas ballast should be used with both pumps; to sweep the vapour through the pump. This prevents condensation and oil contamination. Operate the pump with gas ballast for at least an hour before and after use. Choose the size of pump taking into account the vapour pumping rate.

If you selected a rotary pump, then you should fit a gas ballast oil return kit and mist filter. Change the oil frequently and keep an oil change reminder tag on the pump.

D-Lab would also be a suitable alternative depending on required pumping speed.

Dust and Particle Processes

Question: Which pump and accessory should I use if my process generates dust or grit, which could clog or damage the pump?

Answer: Use a rotary pump fitted with an inlet dust filter. We do not recommend the use of scroll pumps or XDD1 pumps for these applications.

Special Chemical Cleaning Processes

Question: Which pump and accessory should I use if my process generates oxygen or ozone?

Answer: Use a rotary pump adapted to run with Fomblin® oil or nXDS/XDS. Contact Edwards for more information.

Question: Are there any special considerations if my pump will be used in the vicinity of organic gases, like propane?

Answer: Use a rotary pump fitted with a flameproof motor. Contact Edwards for more information.

Contamination

Question: Which pump and accessories should I use if I must ensure that my process and process chamber (operated below 0.1 mb) are not contaminated with oil from the pump?

Answer: Use an nXDS/XDS scroll pump.

Alternatively, you can use a rotary pump with a FL20K foreline trap fitted to the system inlet. The trap contains activated alumina which traps the oil molecules. To maintain the alumina charge, bake the charge basket or replace as required.

Question: How can I reduce the noise level of my pump?

Answer: If the noise is only obvious during pumping down then fitting the exhaust with a silencer (nXDS/XDS pumps), or fitting an exhaust line will reduce the level.

An alternative is to fit an acoustic enclosure. Contact Edwards for more information.

nXDS6i Scroll Pump

The nXDS6i is the next generation in completely oil free, dry scroll pumps and replaces the XDS5. nXDS improves on legacy XDS pumps by offering increased pumping speeds, combined with lower ultimate pressures, lower power consumption and lower noise. Gas ballast allows for pumping of condensable vapours including, water, solvents, dilute acids and bases. nXDS pumps also feature the latest in tip seal technology giving significantly longer life between tip seal changes. Integrated inverter drive with auto sensing voltage input delivers optimized pumping performance globally. nXDS pumps are designed to be completely field serviceable.



Features & Benefits

- Lubricant-free within the vacuum envelope and hermetically sealed means totally clean and dry vacuum to prevent cross contamination
- No atmosphere to vacuum shaft seals means bearings are completely isolated, which prevents process attack and means the bearings run cooler and last longer
- Simple single sided scroll arrangement combined with an innovative motor and bearing design allows for easy field service with a minimum of special tooling for low cost of ownership and maximum up-time
- Improved motor and drive efficiencies for reduced power and cost of ownership
- Advanced interface provides a variety of traditional, analogue and digital control methods enabling remote control/monitoring via USB, RS232 or RS485

Applications

- General clean pumping applications
- Scanning Electron Microscopes - SEM
- Beam lines and high energy physics
- Backing turbo pumps
- Centrifuges, ultra-high speed

Dimensions

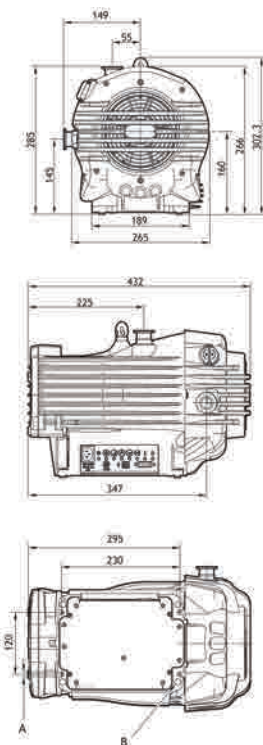

A. 9 wide slots (x 4) B. Rubber feet (x 4)

Performance Curves

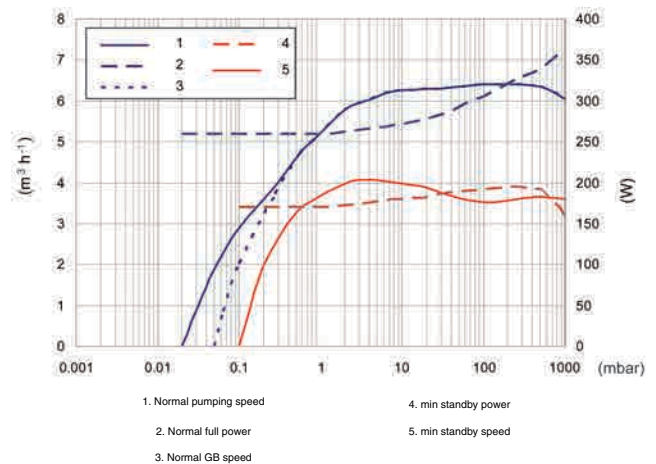

Technical Data

Nominal rotational speed	1800 rpm
Displacement	6.8 m ³ h ⁻¹ / 4.0 ft ³ min ⁻¹
Peak pumping speed	6.2 m ³ h ⁻¹ / 3.6 ft ³ min ⁻¹
Ultimate vacuum (total pressure)	0.020 mbar / 0.015 Torr
Minimum standby rotational speed	1200 rpm
Speed control resolution (percentage of full rotation speed)	1%
Pumping speed at minimum rotational speed	4.1
Maximum continuous inlet pressure	200 mbar
Motor power 1-ph	260 W
Power connector 1-ph	IEC EN60320 C13
Recommended fuse	10A, 250Vac rms
Weight	26.2 kg / 58 lb
Inlet flange	NW25
Exhaust flange	NW25
Noise level	52 dB(A)
Vibration at inlet flange	< 4.5 mms ⁻¹ (rms)
Leak tightness (static)	< 1x10 ⁻⁶ mbar ls ⁻¹
Operating temperature range	10 to 40 °C / 41 to 104 °F

Ordering Information

Product Description	Order No.
nXDS6i 100 - 127 V, 200 - 240 V, 1ph 50/60 Hz	A73501983
Accessories & Spares	Order No.
2m electrical supply cable for 1-ph pumps, no plug	A50508000
2m electrical supply cable for 1-ph pumps, North America/Japan plug	A50507000
2m electrical supply cable for 1-ph pumps, North European plug	A50506000
2m electrical supply cable for 1-ph pumps, UK, Three-pin plug	A50505000
Exhaust silencer	A50597000
Silencer spares kit	A50597800
NW25 Inlet/Outlet exhaust filter 5 Micron	A50597805
1 Micron element	A50597803
5 Micron element	A50597802
Gas Ballast adaptor	A73501809
Gas Ballast adaptor blank	A73501806
Exhaust Nozzle Kit 3/4" To 15mm	A50509000
Vibration isolators	A24801441
Chemical resistance conversion kit	A73501807
nXDS Tip Seal Service Kit	A73501801
nXDS Bearing Replacement Kit	A73501802

nXDS10i Scroll Pump

The nXDS10i is the next generation in completely oil free, dry scroll pumps and replaces the XDS10. nXDS improves on legacy XDS pumps by offering increased pumping speeds, combined with lower ultimate pressures, lower power consumption and lower noise. Gas ballast allows for pumping of condensable vapours including, water, solvents, dilute acids and bases. nXDS pumps also feature the latest in tip seal technology giving significantly longer life between tip seal changes. Integrated inverter drive with auto sensing voltage input delivers optimized pumping performance globally. nXDS pumps are designed to be completely field serviceable.



Features & Benefits

- Lubricant-free within the vacuum envelope and hermetically sealed means totally clean and dry vacuum to prevent cross contamination
- No atmosphere to vacuum shaft seals means bearings are completely isolated, which prevents process attack and means the bearings run cooler and last longer
- Simple single sided scroll arrangement combined with an innovative motor and bearing design allows for easy field service with a minimum of special tooling for low cost of ownership and maximum up-time
- Improved motor and drive efficiencies for reduced power and cost of ownership
- Advanced interface provides a variety of traditional, analogue and digital control methods enabling remote control/monitoring via USB, RS232 or RS485

Applications

- General clean pumping applications
- Scanning Electron Microscopes - SEM
- Beam lines and high energy physics
- Backing turbo pumps
- Centrifuges, ultra-high speed

Dimensions

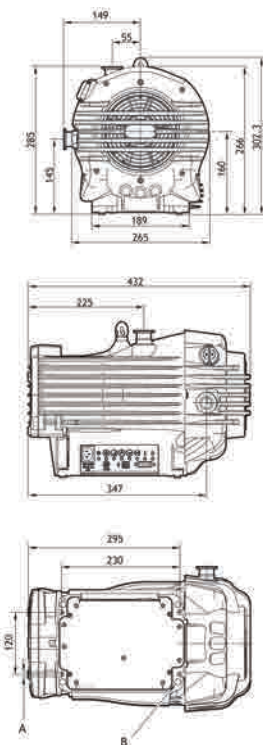

A. 9 wide slots (x 4) B. Rubber feet (x 4)

Performance Curves

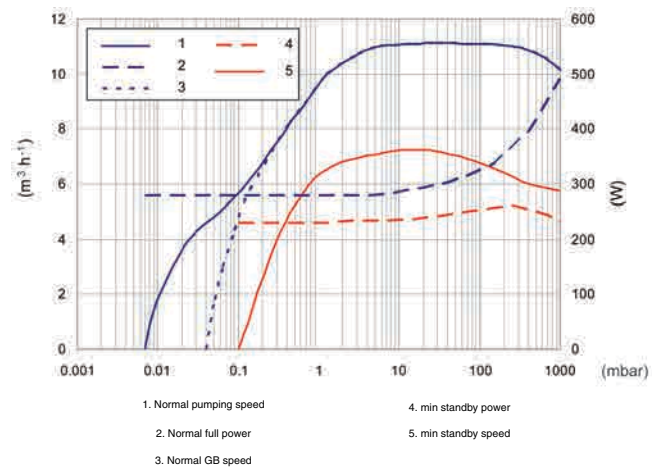

Technical Data

Nominal rotational speed	1800 rpm
Displacement	12.7 m ³ h ⁻¹ / 7.5 ft ³ min ⁻¹
Peak pumping speed	11.4 m ³ h ⁻¹ / 6.7 ft ³ min ⁻¹
Ultimate vacuum (total pressure)	0.007 mbar / 0.005 Torr
Minimum standby rotational speed	1200 rpm
Speed control resolution (percentage of full rotation speed)	1%
Pumping speed at minimum rotational speed	7.5
Maximum continuous inlet pressure	200 mbar
Motor power 1-ph	280 W
Power connector 1-ph	IEC EN60320 C13
Recommended fuse	10A, 250Vac rms
Weight	25.8 kg / 57 lb
Inlet flange	NW25
Exhaust flange	NW25
Noise level	52 dB(A)
Vibration at inlet flange	< 4.5 mms ⁻¹ (rms)
Leak tightness (static)	< 1x10 ⁻⁶ mbar ls ⁻¹
Operating temperature range	10 to 40 °C / 41 to 104 °F

Ordering Information

Product Description	Order No.
nXDS10i 100 - 127 V, 200 - 240 V, 1ph 50/60 Hz	A73601983
Accessories & Spares	Order No.
2m electrical supply cable for 1-ph pumps, no plug	A50508000
2m electrical supply cable for 1-ph pumps, North America/Japan plug	A50507000
2m electrical supply cable for 1-ph pumps, North European plug	A50506000
2m electrical supply cable for 1-ph pumps, UK, Three-pin plug	A50505000
Exhaust silencer	A50597000
Silencer spares kit	A50597800
NW25 Inlet/Outlet exhaust filter 5 Micron	A50597805
1 Micron element	A50597803
5 Micron element	A50597802
Gas Ballast adaptor	A73501809
Gas Ballast adaptor blank	A73501806
Exhaust Nozzle Kit 3/4" To 15mm	A50509000
Vibration isolators	A24801441
Chemical resistance conversion kit	A73501807
nXDS Tip Seal Service Kit	A73501801
nXDS Bearing Replacement Kit	A73501802

nXDS15i Scroll Pump

The nXDS15i is the next generation in completely oil free, dry scroll pumps and can be used to replace similar sized dry pumps and medium sized oil sealed pumps in a variety of applications. nXDS improves on legacy XDS pumps by offering increased pumping speeds, combined with lower ultimate pressures, lower power consumption and lower noise. Gas ballast allows for pumping of condensable vapours including, water, solvents, dilute acids and bases. nXDS pumps also feature the latest in tip seal technology giving significantly longer life between tip seal changes. Integrated inverter drive with auto sensing voltage input delivers optimized pumping performance globally. nXDS pumps are designed to be completely field serviceable.



Features & Benefits

- Lubricant-free within the vacuum envelope and hermetically sealed means totally clean and dry vacuum to prevent cross contamination
- No atmosphere to vacuum shaft seals means bearings are completely isolated, which prevents process attack and means the bearings run cooler and last longer
- Simple single sided scroll arrangement combined with an innovative motor and bearing design allows for easy field service with a minimum of special tooling for low cost of ownership and maximum up-time
- Improved motor and drive efficiencies for reduced power and cost of ownership
- Advanced interface provides a variety of traditional, analogue and digital control methods enabling remote control/monitoring via USB, RS232 or RS485

Applications

- General clean pumping applications
- Scanning Electron Microscopes - SEM
- Beam lines and high energy physics
- Backing turbo pumps
- Centrifuges, ultra-high speed

Dimensions

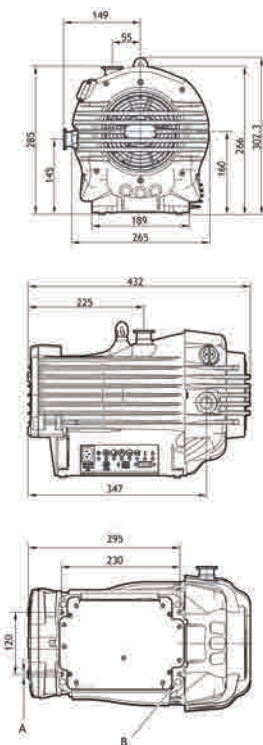

A. 9 wide slots (x 4) B. Rubber feet (x 4)

Performance Curves

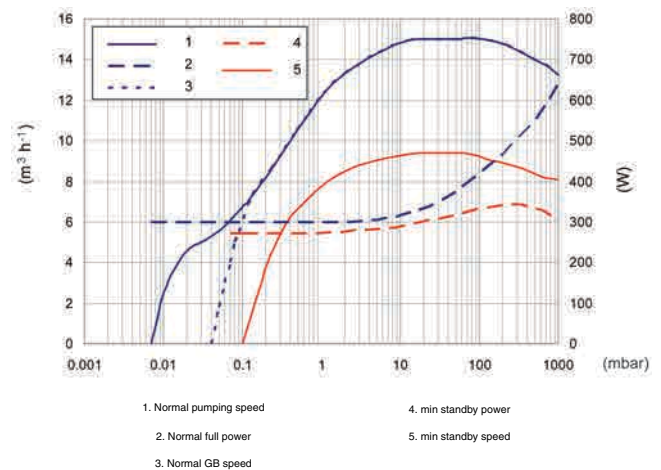

Technical Data

Nominal rotational speed	1800 rpm
Displacement	17.1 m ³ h ⁻¹ / 10.1 ft ³ min ⁻¹
Peak pumping speed	15.1 m ³ h ⁻¹ / 8.9 ft ³ min ⁻¹
Ultimate vacuum (total pressure)	0.007 mbar / 0.005 Torr
Minimum standby rotational speed	1200 rpm
Speed control resolution (percentage of full rotation speed)	1%
Pumping speed at minimum rotational speed	9.9
Maximum continuous inlet pressure	200 mbar
Motor power 1-ph	300 W
Power connector 1-ph	IEC EN60320 C13
Recommended fuse	10A, 250Vac rms
Weight	25.2 kg / 56 lb
Inlet flange	NW25
Exhaust flange	NW25
Noise level	52 dB(A)
Vibration at inlet flange	< 4.5 mms ⁻¹ (rms)
Leak tightness (static)	< 1x10 ⁻⁶ mbar ls ⁻¹
Operating temperature range	10 to 40 °C / 41 to 104 °F

Ordering Information

Product Description	Order No.
nXDS15i 100 - 127 V, 200 - 240 V, 1ph 50/60 Hz	A73701983
Accessories & Spares	Order No.
2m electrical supply cable for 1-ph pumps, no plug	A50508000
2m electrical supply cable for 1-ph pumps, North America/Japan plug	A50507000
2m electrical supply cable for 1-ph pumps, North European plug	A50506000
2m electrical supply cable for 1-ph pumps, UK, Three-pin plug	A50505000
Exhaust silencer	A50597000
Silencer spares kit	A50597800
NW25 Inlet/Outlet exhaust filter 5 Micron	A50597805
1 Micron element	A50597803
5 Micron element	A50597802
Gas Ballast adaptor	A73501809
Gas Ballast adaptor blank	A73501806
Exhaust Nozzle Kit 3/4" To 15mm	A50509000
Vibration isolators	A24801441
Chemical resistance conversion kit	A73501807
nXDS Tip Seal Service Kit	A73501801
nXDS Bearing Replacement Kit	A73501802

nXDS20i Scroll Pump

The nXDS20i is the next generation in completely oil free, dry scroll pumps and can be used to replace similar sized dry pumps and medium sized oil sealed pumps in a variety of applications. nXDS improves on legacy XDS pumps by offering increased pumping speeds, combined with lower ultimate pressures, lower power consumption and lower noise. Gas ballast allows for pumping of condensable vapours including, water, solvents, dilute acids and bases. nXDS pumps also feature the latest in tip seal technology giving significantly longer life between tip seal changes. Integrated inverter drive with auto sensing voltage input delivers optimized pumping performance globally. nXDS pumps are designed to be completely field serviceable.



Features & Benefits

- Lubricant-free within the vacuum envelope and hermetically sealed means totally clean and dry vacuum to prevent cross contamination
- No atmosphere to vacuum shaft seals means bearings are completely isolated, which prevents process attack and means the bearings run cooler and last longer
- Simple single sided scroll arrangement combined with an innovative motor and bearing design allows for easy field service with a minimum of special tooling for low cost of ownership and maximum up-time
- Improved motor and drive efficiencies for reduced power and cost of ownership
- Advanced interface provides a variety of traditional, analogue and digital control methods enabling remote control/monitoring via USB, RS232 or RS485

Applications

- General clean pumping applications
- Scanning Electron Microscopes - SEM
- Beam lines and high energy physics
- Backing turbo pumps
- Centrifuges, ultra-high speed

Dimensions

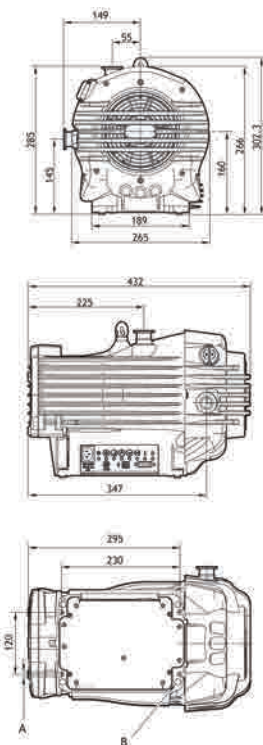

A. 9 wide slots (x 4) B. Rubber feet (x 4)

Performance Curves

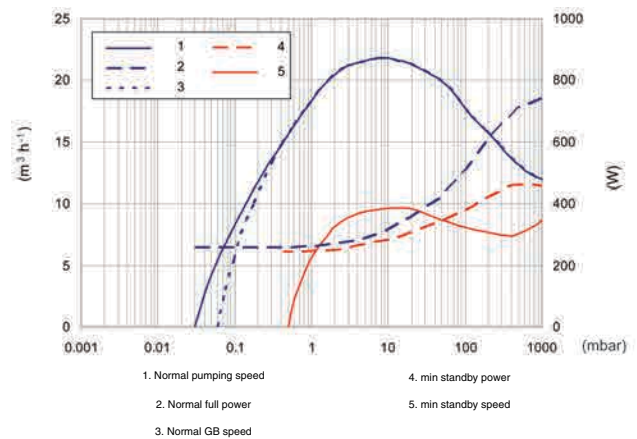

Technical Data

Nominal rotational speed	1800 rpm
Displacement	28.0 m ³ h ⁻¹ / 16.5 ft ³ min ⁻¹
Peak pumping speed	22.0 m ³ h ⁻¹ / 13.0 ft ³ min ⁻¹
Ultimate vacuum (total pressure)	0.030 mbar / 0.022 Torr
Minimum standby rotational speed	1200 rpm
Speed control resolution (percentage of full rotation speed)	1%
Pumping speed at minimum rotational speed	10
Maximum continuous inlet pressure	50 mbar
Motor power 1-ph	260 W
Power connector 1-ph	IEC EN60320 C13
Recommended fuse	10A, 250Vac rms
Weight	25.6 kg / 56 lb
Inlet flange	NW25
Exhaust flange	NW25
Noise level	52 dB(A)
Vibration at inlet flange	< 4.5 mms ⁻¹ (rms)
Leak tightness (static)	< 1x10 ⁻⁶ mbar ls ⁻¹
Operating temperature range	10 to 40 °C / 41 to 104 °F

Ordering Information

Product Description	Order No.
nXDS20i 100 - 127 V, 200 - 240 V, 1ph 50/60 Hz	A73801983
Accessories & Spares	Order No.
2m electrical supply cable for 1-ph pumps, no plug	A50508000
2m electrical supply cable for 1-ph pumps, North America/Japan plug	A50507000
2m electrical supply cable for 1-ph pumps, North European plug	A50506000
2m electrical supply cable for 1-ph pumps, UK, Three-pin plug	A50505000
Exhaust silencer	A50597000
Silencer spares kit	A50597800
NW25 Inlet/Outlet exhaust filter 5 Micron	A50597805
1 Micron element	A50597803
5 Micron element	A50597802
Gas Ballast adaptor	A73501809
Gas Ballast adaptor blank	A73501806
Exhaust Nozzle Kit 3/4" To 15mm	A50509000
Vibration isolators	A24801441
Chemical resistance conversion kit	A73501808
nXDS Tip Seal Service Kit	A73501801
nXDS Bearing Replacement Kit	A73501802

The nXDS-C pump is a modified version of the nXDS that is suitable for use on vapour handling processes, and may be used for some pumping applications involving corrosive substances. The nXDS-C variants have Chemraz® internal valves and stainless steel fittings for extra protection from the pumped media.



Features & Benefits

- Lubricant-free within the vacuum envelope and hermetically sealed means totally clean and dry vacuum to prevent cross contamination
- No atmosphere to vacuum shaft seals means bearings are completely isolated, which prevents process attack and means the bearings run cooler and last longer
- No oil changes required eliminating costs of contaminated oil disposal
- Simple single sided scroll design means routine maintenance is done in minutes for low cost of ownership and maximum up-time
- Gas ballast feature to enable pumping of vapours

Technical Data

Technical Data, Performance curves and Dimensions are as per the standard nXDS pumps.

Ordering Information

Product Description	Order No.
nXDS6iC 100 - 127 V, 200 - 240 V, 1ph 50 - 60 Hz	A73502983
nXDS10iC 100 - 127 V, 200 - 240 V, 1ph 50 - 60 Hz	A73602983
nXDS15iC 100 - 127 V, 200 - 240 V, 1ph 50 - 60 Hz	A73702983
nXDS20iC 100 - 127 V, 200 - 240 V, 1ph 50 - 60 Hz	A73802983
Accessories & Spares	Order No.
2m electrical supply cable for 1-ph pumps, no plug	A50508000
2m electrical supply cable for 1-ph pumps, North America/Japan plug	A50507000
2m electrical supply cable for 1-ph pumps, North European plug	A50506000
2m electrical supply cable for 1-ph pumps, UK, Three-pin plug	A50505000
nXDS Bearing Replacement Kit	A73501802
nXDS Tip Seal Service Kit	A73501801

XDS35i Scroll Vacuum Pump

1

Page
14



The XDS35i pump has an innovative bearing shield design that isolates the vacuum environment from all forms of lubricant, not only making it totally dry but hermetically sealed. The shield also protects the bearing from any process vapours. Gas ballast allows vapour to be handled and opens up the range of applications to many that were previously unsuited to scroll pumps. The inverter drive controls the motor characteristics and ensures the pump always runs at optimum speed.

Features & Benefits

- Lubricant-free within the vacuum envelope and hermetically sealed means totally clean and dry vacuum to prevent cross contamination
- No atmosphere to vacuum shaft seals means bearings are completely isolated, this prevents process attack and means bearings run cooler and last longer
- No oil changes required eliminating costs of contaminated oil disposal
- Simple single sided scroll design means maintenance is done in minutes for low cost of ownership and maximum up-time
- Inverter drive for consistent pumping speed at 50/60Hz

Dimensions

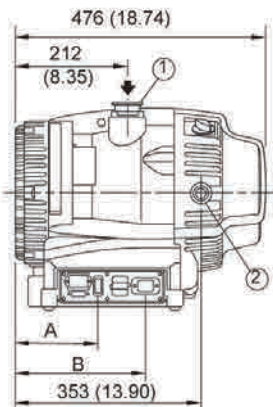
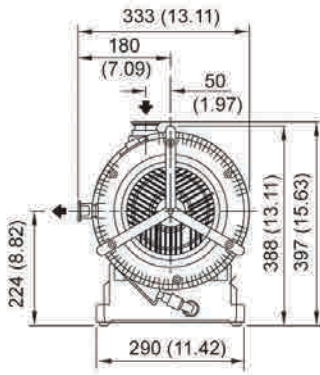

A. 150 (5.91)

B. 247.5 (9.74)

1. NW40

2. NW25

Applications

- Clean pumping applications
- Automotive
- Beam lines and high energy physics
- Centrifuges, ultra high speed
- Coating

Performance Curves

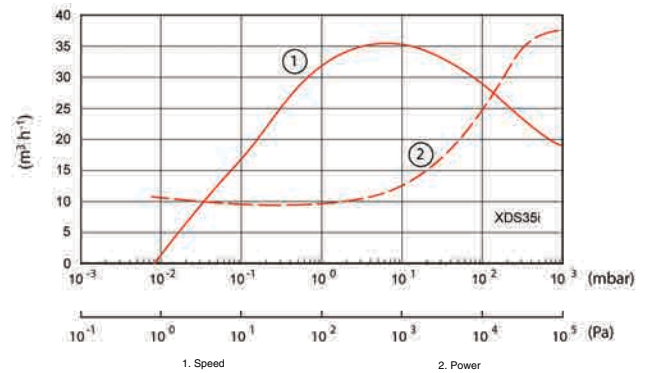

Technical Data

Displacement 50 or 60Hz	43 m ³ h ⁻¹ / 25 ft ³ min ⁻¹
Peak pumping speed 50 or 60Hz	35 m ³ h ⁻¹ / 21 ft ³ min ⁻¹
Ultimate vacuum (Total pressure)	1 x 10 ⁻² mbar / 8 x 10 ⁻³ Torr
Max inlet pressure for water vapour	35 mbar / 23 Torr
Max water vapour pumping rate – GB I	70 gh ⁻¹
Max water vapour pumping rate – GB II	240 gh ⁻¹
Max allowed outlet pressure	0.2 bar gauge / 2.9 psig*
Max allowed inlet and GB pressure	0.5 bar gauge / 7 psig
Motor power	0.52kW
Power connector	IEC EN60320 C19
Nominal rotation speed	1750 rpm
Weight	48 kg / 105 lb
Inlet flange	NW40
Exhaust flange	NW25
Noise level	57 dB (A)
Vibration	<4.5mms ⁻¹ (rms)
Leak tightness (static)	<1 x 10 ⁻⁶ mbar ls ⁻¹
Operating temperature range	10 to 40 °C / 50 to 104 °F

* 1 bar gauge / 14 psig for short period of time only.

Ordering Information

Product Description	Order No.
XDS35i 100-120/200-230V, 1-ph, 50/60Hz with an IEC60320 connector, factory set to 230V	A73001983
Accessories & Spares	Order No.
2m Electrical supply cable, no plug	A50508003
2m Electrical supply cable, North America/Japan plug	A50507003
2m Electrical supply cable, North European plug	A50506003
2m Electrical supply cable, UK, three-pin plug	A50505003
Exhaust silencer XDS35i	A50597001
Gas Ballast Adapter with 0.25mm hole	A50626801
Silencer spares kit	A50597801
Tip seal kit XDS35i	A73001801

XDS46i Scroll Vacuum Pump

1

Page
16



The XDS46i pump is a development on the XDS35i and thus shares many of the same features and benefits but with a peak speed boosted to 40m³/hr. The XDS46i is optimised for maximum pumping speed at inlet pressures between 1 mbar and 10 mbar making it ideally suited for LCMS and ICPMS applications requiring a higher pumping speed than that offered by the XDS35i. Recent improvements in tip seal technology have lead to reduced tip seal wear therefore giving a longer time between service interventions. The inverter drive controls the motor characteristics and ensures the pump always runs at optimum speed and allows the user to control the pump remotely.

Features & Benefits

- Lubricant-free within the vacuum envelope and hermetically sealed means totally clean and dry vacuum to prevent cross contamination
- No atmosphere to vacuum shaft seals means bearings are completely isolated, this prevents process attack and means bearings run cooler and last longer
- No oil changes required eliminating costs of contaminated oil disposal
- Simple single sided scroll design means maintenance is done in minutes for low cost of ownership and maximum up-time
- Inverter drive for consistent pumping speed at 50/60Hz

Dimensions

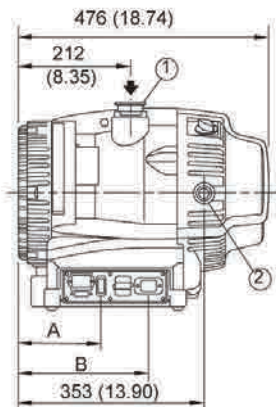
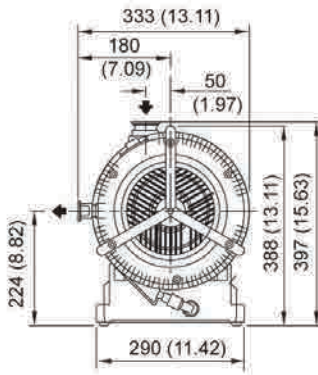

A. 150 (5.91)

B. 247.5 (9.74)

1. NW40

2. NW25

Applications

- LCMS inlet
- ICPMS inlet
- Coating

Performance Curves

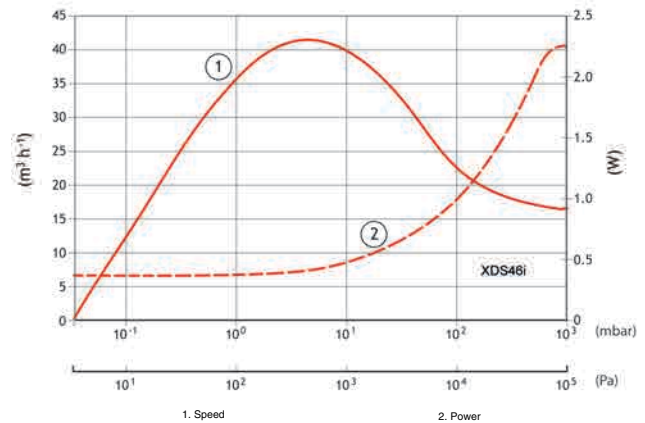

Technical Data

Displacement 50 or 60Hz	60 m ³ h ⁻¹ / 35 ft ³ min ⁻¹
Peak pumping speed 50 or 60Hz	40 m ³ h ⁻¹ / 23.5 ft ³ min ⁻¹
Ultimate vacuum (Total pressure)	5 x 10 ⁻² mbar / 4 x 10 ⁻² Torr
Max continuous inlet pressure	40 mbar / 30 Torr
Max continuous outlet pressure	0.2 bar gauge / 2.9 psig
Max allowed inlet and GB pressure	0.5 bar gauge / 7 psig
Motor power	0.52kW
Power connector	IEC EN60320 C19
Nominal rotation speed	1750 rpm
Weight	48 kg / 105 lb
Inlet flange	NW40
Exhaust flange	NW25
Noise level	55.4 dB (A)
Vibration	<4.5mm s ⁻¹ (rms)
Leak tightness (static)	<1 x 10 ⁻⁶ mbar ls ⁻¹
Operating temperature range	10 to 40 °C / 50 to 104 °F

Ordering Information

Product Description	Order No.
XDS46i 100-120/200-230V, 1-ph, 50/60Hz with an IEC60320 connector, factory set to 230V	A73101983
Accessories & Spares	Order No.
Gas Ballast Adapter with 0.25mm hole	A50626801
Exhaust silencer XDS35i	A50597001
Silencer spares kit	A50597801
2m Electrical supply cable, UK, three-pin plug	A50505003
2m Electrical supply cable, North European plug	A50506003
2m Electrical supply cable, North America/Japan plug	A50507003
2m Electrical supply cable, no plug	A50508003
Tip seal kit XDS46i	A73101801

XDS100B Scroll Booster Vacuum Pump

1

Page
18



The XDS100B is a scroll booster, with a pumping mechanism designed specifically for high pumping speed. Like all booster pumps, it needs to be used in conjunction with a primary pump and is ideally matched with Edwards XDS35i or XDS46i scroll pumps. The XDS100B is optimised for maximum pumping speed at inlet pressures between 1 mbar and 10 mbar making it ideally suited for ultra high throughput LCMS applications. The advanced pump design has resulted in virtually no tip seal wear thus reducing service intervention and maximising uptime.

The inverter drive allows the pump to be connected to a single phase supply and controls the motor characteristics and ensures the pump always runs at optimum speed and allows the user to control the pump remotely.

Features & Benefits

- Lubricant-free within the vacuum envelope and hermetically sealed means totally clean and dry vacuum to prevent cross contamination
- No atmosphere to vacuum shaft seals means bearings are completely isolated, this prevents process attack and means bearings run cooler and last longer
- No oil changes required eliminating costs of contaminated oil disposal
- Simple single sided scroll design means maintenance is done in minutes for low cost of ownership and maximum up-time
- Inverter drive for consistent pumping speed at 50/60Hz

Dimensions

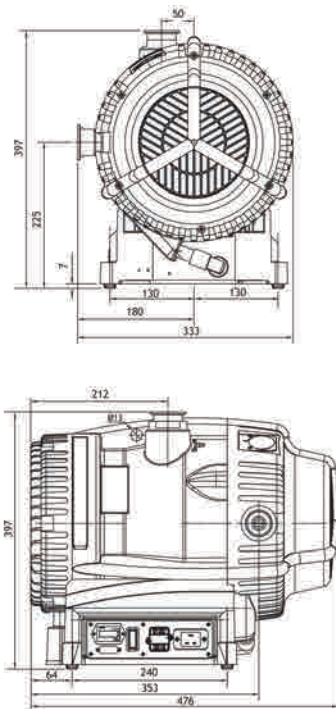

Applications

- High throughput – LCMS

Performance Curves

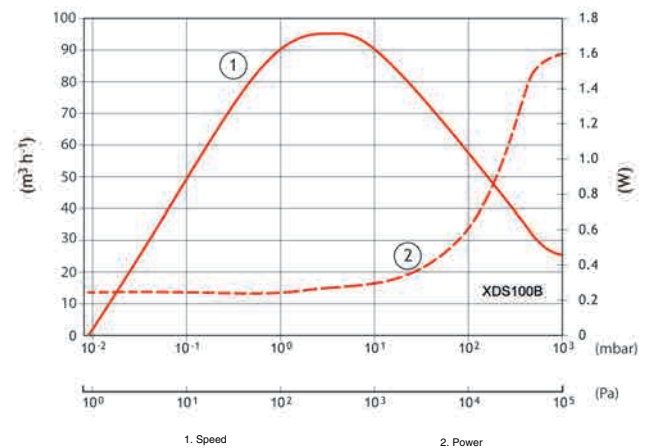

Technical Data

Pumping speed	
50 or 60Hz	95 m ³ h ⁻¹ / 56 ft ³ min ⁻¹
Ultimate vacuum (Total pressure)*	<1 x 10 ⁻² mbar / <8 x 10 ⁻³ Torr
Max continuous inlet pressure	20 mbar / 15 Torr
Max continuous outlet pressure	60 mbar / 45 Torr
Max permitted inlet pressure for short duration	0.5 bar gauge / 7 psig
Max chamber volume to pump down from atmosphere	100 litres
Max chamber volume for cyclic duty – max 6 per hour	50 litres
Motor power	0.52kW
Nominal rotation speed	1750 rpm
Weight	48 kg / 105 lb
Inlet flange	NW40
Exhaust flange	NW40
Noise level	52.1 dB (A)
Vibration	<4.5mms ⁻¹ (rms)
Leak tightness (static)	<1 x 10 ⁻⁶ mbar ls ⁻¹
Operating temperature range	10 to 40 °C / 50 to 104 °F

* Ultimate pressure is backing pump dependant

Ordering Information

Product Description	Order No.
XDS100B 1-ph, 100-120/200-230V Set to 230V	A73201983
Accessories & Spares	Order No.
2m Electrical supply cable, UK, three-pin plug	A50505003
2m Electrical supply cable, North European plug	A50506003
2m Electrical supply cable, North America/Japan plug	A50507003
2m Electrical supply cable, no plug	A50508003
Tip seal kit XDS35i	A73001801

NGB Scroll Vacuum Pumps

1

Page
20



NGB pumps are standard nXDS/XDS pumps but with the gas ballast feature removed. They are for applications where it is advantageous to have the gas ballast control knob and machining removed so that it cannot be accidentally opened. Example applications include rare gas recirculation and gas recovery.

Note: Mains leads must be ordered separately, please see the catalogue entry for the relevant standard nXDS/XDS pump for the correct mains lead.

Applications

- Rare gas recirculation
- Gas recovery

Features & Benefits

- Lubricant-free within the vacuum envelope and hermetically sealed means totally clean and dry vacuum to prevent cross contamination
- No atmosphere to vacuum shaft seals means bearings are completely isolated, which prevents process attack and means the bearings run cooler and last longer
- No oil changes required eliminating costs of contaminated oil disposal
- Simple single sided scroll design means routine maintenance is done in minutes for low cost of ownership and maximum up-time
- No gas ballast to eliminate accidental opening and resultant ingress of air

Technical Data

Technical Data and Dimensions are as per the standard nXDS/XDS pumps but ignoring the water vapour handling capability and gas ballast facility.

Ordering Information

Product Description	Order No.
XDS35i-NGB 1-ph 100-120/200-230V set to 230V	A73005983
nXDS6iR 100 - 127 V, 200 - 240 V, 1ph 50 - 60 Hz	A73503983
nXDS10iR 100 - 127 V, 200 - 240 V, 1ph 50 - 60 Hz	A73603983
nXDS15iR 100 - 127 V, 200 - 240 V, 1ph 50 - 60 Hz	A73703983
nXDS20iR 100 - 127 V, 200 - 240 V, 1ph 50 - 60 Hz	A73803983
Accessories & Spares	Order No.
2m electrical supply cable for 1-ph pumps, no plug	A50508000
2m electrical supply cable for 1-ph pumps, North America/Japan plug	A50507000
2m electrical supply cable for 1-ph pumps, North European plug	A50506000
2m electrical supply cable for 1-ph pumps, UK, Three-pin plug	A50505000
Exhaust silencer	A50597000
Silencer spares kit	A50597800
Exhaust silencer XDS35i	A50597001
Silencer spares kit	A50597801
NW25 inlet/exhaust filter with 5µm element	A50597805
NW40 inlet filter with 5µm element	NRD383000
NW40 low profile inlet filter with 5µm element	NRD386000
Replacement 1µm element for NW25 filter	A50597803
Replacement 1µm element for NW40 filter	NRD385000
Replacement 1µm element for NW40 low profile filter	NRD388000
Replacement 5µm element for NW25 filter	A50597802
Replacement 5µm element for NW40 filter	NRD384000
Replacement 5µm element for NW40 low profile filter	NRD387000
Tip seal kit XDS35i	A73001801
nXDS Tip Seal Service Kit	A73501801
nXDS Bearing Replacement Kit	A73501802

Dimensions

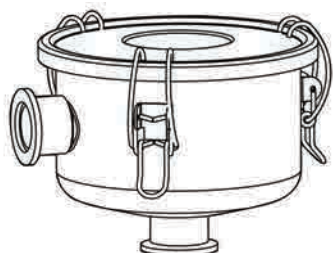

nXDS Filter

E2M0.7 Two Stage Rotary Vane Pump



The E2M0.7 is a small two stage oil sealed rotary vane pump that features a very low sound level of only 43 dB(A), compact dimensions, low energy consumption and low operating temperature. It will appeal to scientific instrument manufacturers and laboratory users for backing small turbomolecular or diffusion pumps as well as general laboratory applications.

Fitted in a cabinet, the pump will be virtually inaudible and the low operating temperature will minimize the heat load on the equipment. Vertical vacuum inlet with horizontal option.

Supplied with: Ultragrade 15 oil, NW O-ring and centering ring, 2 Allen keys and spare seals for oil drain and filler plugs.



Features & Benefits

- Very low sound level of only 43 dB(A).
- The pump is designed for reliable, long-term operation.
- Compact dimensions.
- Low energy consumption.
- Low operating temperature will minimize the heat load on the equipment.

Applications

- Analytical instruments
- Leak detectors, Helium
- Research and development
- Backing Turbomolecular pumps

Dimensions

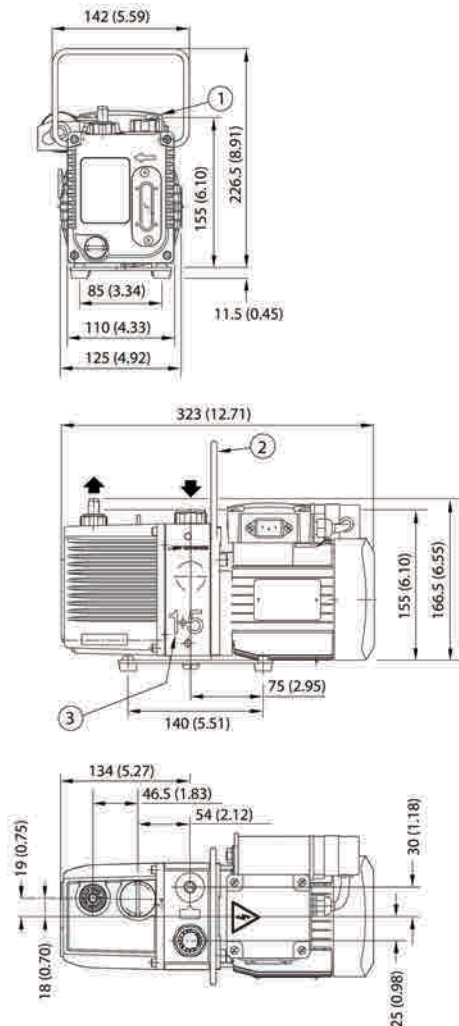

1. 220-240 V motor 2. Handle (can be removed) 3. Alternative inlet position

Performance Curves

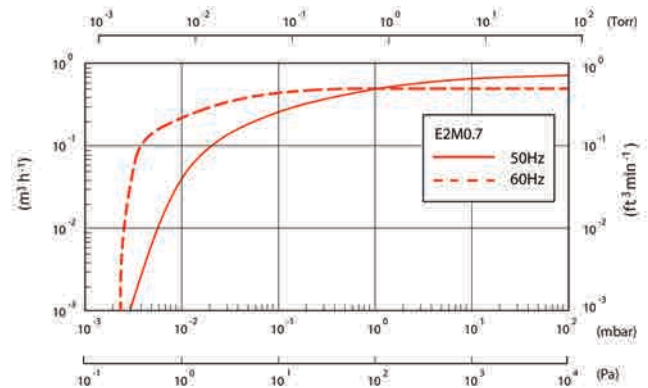

Technical Data

Displacement (swept volume)	
50 Hz	$0.9 \text{ m}^3 \text{ h}^{-1} / 0.5 \text{ ft}^3 \text{ min}^{-1}$
60 Hz	$1.1 \text{ m}^3 \text{ h}^{-1} / 0.6 \text{ ft}^3 \text{ min}^{-1}$
Speed (Pneurop 6602)	
50 Hz	$0.75 \text{ m}^3 \text{ h}^{-1} / 0.4 \text{ ft}^3 \text{ min}^{-1}$
60 Hz	$0.95 \text{ m}^3 \text{ h}^{-1} / 0.5 \text{ ft}^3 \text{ min}^{-1}$
Ultimate vacuum (total pressure)	
without gas ballast	$3.0 \times 10^{-3} \text{ mbar} / 2.3 \times 10^{-3} \text{ Torr}$
with full gas ballast	$2.0 \times 10^{-1} \text{ mbar} / 1.5 \times 10^{-1} \text{ Torr}$
Inlet connection	NW10 flange
Outlet connection	Nozzle 11 mm external Ø removable from 3/8 inch BSP tapped hole
Maximum permitted pressure at outlet	0.5 bar gauge / 7 psig
Maximum inlet pressure for water vapour	15 mbar / 11 Torr
Maximum water vapour pumping rate	8 gh^{-1}
Motor power	0.09 kW
Nominal rotational speed 50/60Hz	1400/1700 rpm
Power connector	IEC EN60320 C13
Operating temperature range	12 - 40 °C
Weight, without oil	10 kg / 22 lbs
Noise	43 dB(A) @ 50 Hz
Oil capacity - maximum	0.28 litre
Oil capacity - minimum	0.2 litre
Recommended oil (supplied)	Ultragrade 15

Ordering Information

Product Description	Order No.
E2M0.7 200-230V, 1-ph, 50/60Hz, IEC 60320 connectors	A37141919
E2M0.7 100-120V, 1-ph, 50/60Hz, IEC 60320 connectors	A37141902
Accessories & Spares	Order No.
Model EMF3 mist filter	A46220000
2m electrical supply cable for 1-ph pumps, UK, Three-pin plug	A50505000
2m electrical supply cable for 1-ph pumps, North European plug	A50506000
2m electrical supply cable for 1-ph pumps, North America/Japan plug	A50507000
2m electrical supply cable for 1-ph pumps, no plug	A50508000
Spares Kit C&O E2M0.7/1/1.5	A37101131
Spares Kit Blade E2M0.7/1.5	A37101132
NW10/10 Centring Nitrile S/S Pk1	C10511396
NW10 O Ring Viton Pk 5	H02124032
NW10 x 3/8" BSP Adapter	A25908064

E2M1.5 Two Stage Rotary Vane Pump



The E2M1.5 is a two stage oil sealed rotary vane pump suitable for many bench type applications. The pump features an alternative inlet connection position at the side of the pump so that overall installation height can be reduced to a minimum when required.

The interstage version features an additional pumping port to provide a rough vacuum for auxiliary duties.

Supplied with: Ultrgrade 15 oil, NW O-ring, centering ring, 2 Allen keys and spare seals for oil drain and filler plugs.



Features & Benefits

- The pump is designed for reliable, long-term operation.
- Compact dimensions.
- Low energy consumption.
- The interstage version features an additional pumping port to provide a rough vacuum for auxiliary duties.
- The pump is a free-standing unit.

Applications

- Analytical instruments
- Laboratory bench top vacuum
- Leak detectors, Helium
- Research and development
- Backing turbomolecular pumps

Dimensions

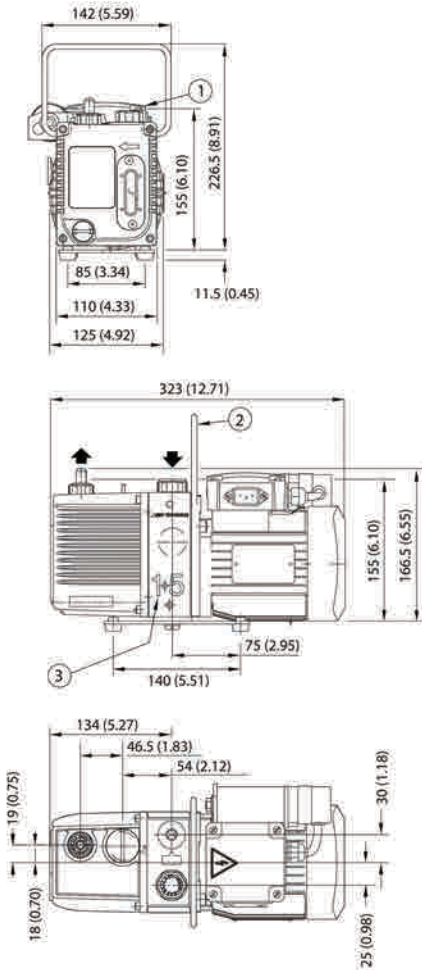

1. 220-240 V motor 2. Handle (can be removed) 3. Alternative inlet position

Performance Curves

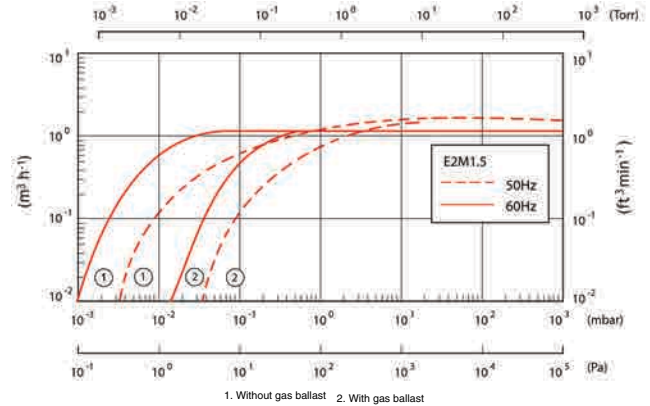

Technical Data

Displacement (swept volume)	
50 Hz	1.8 m ³ h ⁻¹ / 1 ft ³ min ⁻¹
60 Hz	2.2 m ³ h ⁻¹ / 1.3 ft ³ min ⁻¹
Speed (Pneurop 6602)	
50 Hz	1.6 m ³ h ⁻¹ / 0.8 ft ³ min ⁻¹
60 Hz	2.0 m ³ h ⁻¹ / 1.2 ft ³ min ⁻¹
Ultimate vacuum (total pressure)	
without gas ballast	3 x 10 ⁻³ mbar / 2.3 x 10 ⁻³ Torr
with gas ballast	2.5 x 10 ⁻² mbar / 1.9 x 10 ⁻² Torr
Inlet connection	NW10 flange
Outlet connection	Nozzle 11 mm external diameter removable from hole tapped 3/8 inch BSP
Maximum permitted pressure at outlet	0.5 bar gauge / 7 psig
Maximum inlet pressure for water vapour	15 mbar / 11 Torr
Maximum water vapour pumping rate	16 gh ⁻¹
Motor power 50/60 Hz (IP54)	0.16 kW
Nominal rotation speed 50/60Hz	2800/3400 rpm
Power connector	IEC EN60320 C13
Operating temperature range	12 - 40 °C
Weight	10 kg / 22 lbs
Noise	54 dB (A) @ 50 Hz
Oil capacity - max	0.28 litre
min	0.2 litre
Recommended oil (supplied)	Ultragrade 15

Ordering Information

Product Description	Order No.
E2M1.5 200-230V, 1-ph, 50/60Hz, IEC 60320 connectors	A37132919
E2M1.5 100-120V, 1-ph, 50/60Hz, IEC 60320 connectors	A37132902
E2M1.5 interstage 200-230V, 1-ph, 50/60Hz, IEC 60320 connectors	A37104919
E2M1.5 interstage 100-120V, 1-ph, 50/60Hz, IEC 60320 connectors	A37104902
Accessories & Spares	Order No.
Model EMF3 mist filter	A46220000
2m electrical supply cable for 1-ph pumps, UK, Three-pin plug	A50505000
2m electrical supply cable for 1-ph pumps, North European plug	A50506000
2m electrical supply cable for 1-ph pumps, North America/Japan plug	A50507000
2m electrical supply cable for 1-ph pumps, no plug	A50508000
Spares Kit C&O E2M0.7/1/1.5	A37101131
Spares Kit Blade E2M0.7/1.5	A37101132
NW10/10 Centring Nitrile S/S Pk1	C10511396
NW10 O Ring Viton Pk 5	H02124032
NW10 x 3/8" BSP Adapter	A25908064

RV3 Two Stage Rotary Vane Pump



Edwards RV pumps have become the industry standard for scientific primary pumping applications. RV pumps are uniquely capable of delivering high or low throughputs with high ultimate vacuum. This, combined with ultra-low noise levels, makes them ideal for a wide range of applications including GCMS and other small bench top type applications.

All pumps are approved to UL and CSA standards by an external test house. Edwards has a global network, providing world-wide support for product applications and service.

Supplied with: 1 litre of Ultragrade 19 oil, inlet filter and O-ring. Fomblin® must be purchased separately for PFPE RV pumps.



Features & Benefits

- 48 dB(A) and intrusive frequencies minimised.
- Dual mode. Suitable for high throughput and high vacuum applications.
- Easy-to-use gas ballast.
- Fast acting inlet valve for system protection.
- High torque, dual voltage/dual frequency motor, electronic start relay.

Applications

- Analytical instruments
- Laboratory bench top vacuum
- Turbomolecular backing pumps
- Freeze drying
- Research and development

Dimensions

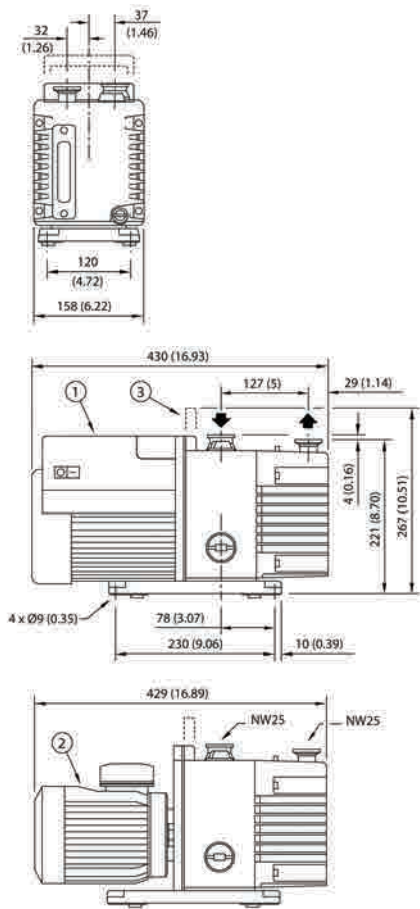

1. 1-phase motor 2. 3-phase motor 3. Retractable handle

Performance Curves

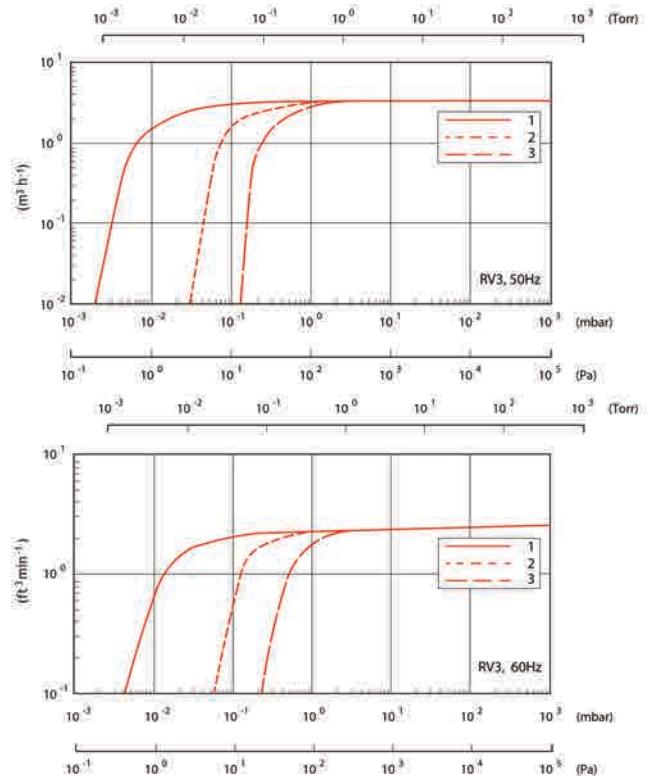

1. High vacuum mode, gas ballast = 0
 2. High throughput mode, gas ballast = 0 and high vacuum mode, gas ballast = 1
 3. High vacuum and throughput modes, gas ballast = 1

Technical Data

Displacement	
50Hz	3.7 m ³ h ⁻¹ / 2.2 ft ³ min ⁻¹
60Hz	4.5 m ³ h ⁻¹ / 2.6 ft ³ min ⁻¹
Speed (Pneurop 6602)	
50Hz	3.3 m ³ h ⁻¹ / 2 ft ³ min ⁻¹
60Hz	3.9 m ³ h ⁻¹ / 2.3 ft ³ min ⁻¹
Ultimate pressure	2.0 x 10 ⁻³ mbar / 1.5 x 10 ⁻³ Torr
Ultimate pressure GB I	3.0 x 10 ⁻² mbar / 2.3 x 10 ⁻² Torr
Ultimate pressure GB II	1.2 x 10 ⁻¹ mbar / 9.1 x 10 ⁻² Torr
Ultimate Pressure with Fomblin®	2 x 10 ⁻² mbar / 1.5 x 10 ⁻² Torr
Max inlet pressure for water vapour	80 mbar / 60 Torr
Max water vapour pumping rate – GB I	60 gh ⁻¹
Max water vapour pumping rate – GB II	220 gh ⁻¹
Max allowed outlet pressure	1 bar gauge / 14 psig
Max allowed inlet and gas ballast pressure	0.5 bar gauge / 7 psig
Motor power 50/60Hz	450 / 550W
Power connector 1-ph	IEC EN60320 C13
Nominal rotation speed 50/60Hz	1500 / 1800rpm
Weight (without oil)	25 kg / 55 lb
Oil capacity min/max	0.42/0.7 litres
Recommended oil	Ultragrade 19
Inlet flange	NW25
Exhaust flange	NW25
Noise level	48 dB(A) @ 50 Hz
Operating temperature range	12 – 40 °C

Ordering Information

Product Description	Order No.
RV3 115/230V, 1-ph, 50/60Hz, Factory set to 230V for Europe	A65201903
RV3 100/200V, 1-ph, 50/60Hz, Factory set to 200V for Japan	A65201904
RV3 200-220/380-415V, 3-ph, 50Hz and 200-230/460V, 3-ph, 60Hz Factory set to 380/460V	A65201905
RV3 115/230V, 1-ph, 50/60Hz, Factory set to 115V for USA	A65201906
PFPE RV3 115/230V, 1-ph, 50/60 Hz, Factory set to 230V for Europe	A65209903
PFPE RV3 100/200V, 1-ph, 50/60Hz, Factory set to 200V for Japan	A65209904
PFPE RV3 200-220/380-415V, 3-ph, 50Hz and 200-230/460V, 3-ph, 60Hz, Factory set to 380/460V	A65209905
PFPE RV3 115/230V, 1-ph, 50/60Hz, Factory set to 115V for USA	A65209906
Accessories & Spares	Order No.
2m electrical supply cable for 1-ph pumps, UK, Three-pin plug	A50505000
2m electrical supply cable for 1-ph pumps, North European plug	A50506000
2m electrical supply cable for 1-ph pumps, North America/Japan plug	A50507000
2m electrical supply cable for 1-ph pumps, no plug	A50508000
RV gas-ballast adaptor	A50502000
Exhaust Nozzle Kit 3/4" To 15mm	A50509000
Model EMF10 mist filter	A46226000
Clean and overhaul kit	A65201131
Clean and overhaul kit (Nitrile)	A65201137
Blade Kit RV3	A65201130
Outer Shaft Seal Kit RV	A65201134
Spares Kit Inlet Valve RV3/5/8/12	A65201036
Spares Kit Cartridge RV3	A65201032

RV5 Two Stage Rotary Vane Pump

Edwards RV pumps have become the industry standard for scientific primary pumping applications. RV pumps are uniquely capable of delivering high or low throughputs with high ultimate vacuum. This, combined with ultra-low noise levels, makes them ideal for a wide range of applications including GCMS and other small bench top type applications.

All pumps are approved to UL and CSA standards by an external test house. Edwards has a global network, providing world-wide support for product applications and service.

Supplied with: 1 litre of Ultragrade 19 oil, inlet filter and O-ring. Fomblin® must be purchased separately for PFPE RV pumps.



Features & Benefits

- 48 dB(A) and intrusive frequencies minimised.
- Dual mode. Suitable for high throughput and high vacuum applications.
- Easy-to-use gas ballast.
- Fast acting inlet valve for system protection.
- High torque, dual voltage/dual frequency motor, electronic start relay.

Applications

- Analytical instruments
- Centrifuges, ultra-high speed
- Coating
- Degassing/curing - oil, epoxy resin
- Distillation/extraction/filtration

Dimensions

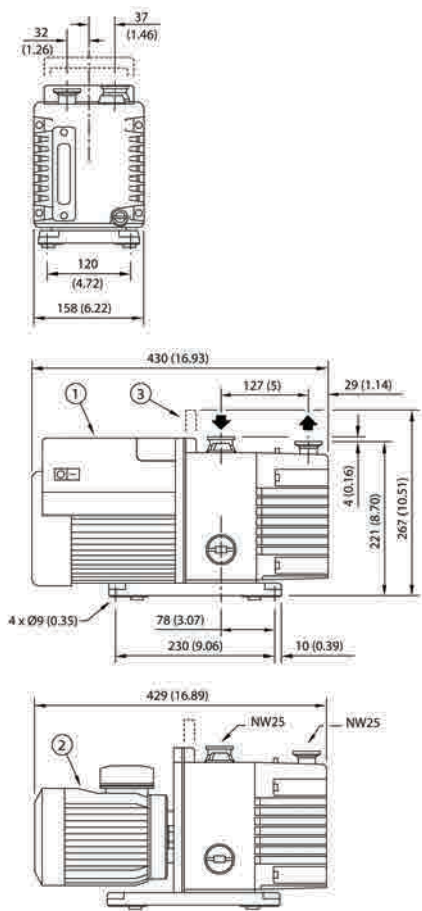

1. 1-phase motor 2. 3-phase motor 3. Retractable handle

Performance Curves

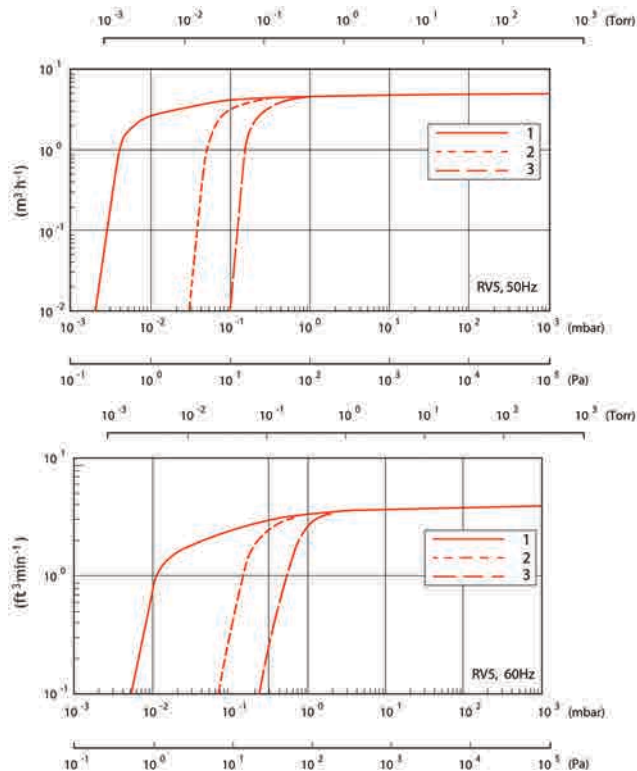

1. High vacuum mode, gas ballast = 0
 2. High throughput mode, gas ballast = 0 and high vacuum mode, gas ballast = 1
 3. High vacuum and throughput modes, gas ballast = II

Technical Data

Displacement	
50Hz	5.8 m ³ h ⁻¹ / 3.4 ft ³ min ⁻¹
60Hz	7.0 m ³ h ⁻¹ / 4.1 ft ³ min ⁻¹
Speed (Pneurop 6602)	
50Hz	5.1 m ³ h ⁻¹ / 3.0 ft ³ min ⁻¹
60Hz	6.2 m ³ h ⁻¹ / 3.7 ft ³ min ⁻¹
Ultimate pressure	2.0 x 10 ⁻³ mbar / 1.5 x 10 ⁻³ Torr
Ultimate pressure GB I	3.0 x 10 ⁻² mbar / 2.3 x 10 ⁻² Torr
Ultimate pressure GB II	1.0 x 10 ⁻¹ mbar / 7.5 x 10 ⁻² Torr
Ultimate Pressure with Fomblin®	2.0 x 10 ⁻² mbar / 1.5 x 10 ⁻² Torr
Max inlet pressure for water vapour	50 mbar / 38 Torr
Max water vapour pumping rate – GB I	60 gh ⁻¹
Max water vapour pumping rate – GB II	220 gh ⁻¹
Max allowed outlet pressure	1 bar gauge / 14 psig
Max allowed inlet and gas ballast pressure	0.5 bar gauge / 7 psig
Motor power 50/60Hz	450 / 550W
Power connector 1-ph	IEC EN60320 C13
Nominal rotation speed 50/60Hz	1500 / 1800rpm
Weight (without oil)	25 kg / 55 lb
Oil capacity min/max	0.42/0.7 litres
Recommended oil	Ultragrade 19
Inlet flange	NW25
Exhaust flange	NW25
Noise level	48 dB(A) @ 50 Hz
Operating temperature range	12 – 40 °C

Ordering Information

Product Description	Order No.
RV5 115/230V, 1-ph, 50/60Hz, Factory set to 230V for Europe	A65301903
RV5 100/200V, 1-ph, 50/60Hz, Factory set to 200V for Japan	A65301904
RV5 200-220/380-415V, 3-ph, 50Hz and 200-230/460V, 3-ph, 60Hz, Factory set to 380/460V	A65301905
RV5 115/230V, 1-ph, 50/60Hz, Factory set to 115V for USA	A65301906
PFPE RV5 115/230V, 1-ph, 50/60Hz, Factory set to 230V for Europe	A65309903
PFPE RV5 100/200V, 1-ph, 50/60Hz, Factory set to 200V for Japan	A65309904
PFPE RV5 200-220/380-415V, 3-ph, 50Hz and 200-230/460V, 3-ph, 60Hz, Factory set to 380/460V	A65309905
PFPE RV5 115/230V, 1-ph, 50/60Hz, Factory set to 115V for USA	A65309906
Accessories & Spares	Order No.
2m electrical supply cable for 1-ph pumps, UK, Three-pin plug	A50505000
2m electrical supply cable for 1-ph pumps, North European plug	A50506000
2m electrical supply cable for 1-ph pumps, North America/Japan plug	A50507000
2m electrical supply cable for 1-ph pumps, no plug	A50508000
RV gas-ballast adaptor	A50502000
Exhaust Nozzle Kit 3/4" To 15mm	A50509000
Model EMF10 mist filter	A46226000
Clean and overhaul kit	A65201131
Clean and overhaul kit (Nitrile)	A65201137
Spares Kit Blade RV5	A65301130
Outer Shaft Seal Kit RV	A65201134
Spares Kit Inlet Valve RV3/5/8/12	A65201036
Spares Kit Cartridge RV5	A65301032

RV8 Two Stage Rotary Vane Pump

Edwards RV pumps have become the industry standard for scientific primary pumping applications. RV pumps are uniquely capable of delivering high or low throughputs with high ultimate vacuum. This, combined with ultra-low noise levels, makes them ideal for a wide range of applications including GCMS and other small bench top type applications.

All pumps are approved to UL and CSA standards by an external test house. Edwards has a global network, providing world-wide support for product applications and service.

Supplied with: 1 litre of Ultragrade 19 oil, inlet filter and O-ring. Fomblin® must be purchased separately for PFPE RV pumps.



Features & Benefits

- 48 dB(A) and intrusive frequencies minimised.
- Dual mode. Suitable for high throughput and high vacuum applications.
- Easy-to-use gas ballast.
- Fast acting inlet valve for system protection.
- High torque, dual voltage/dual frequency motor, electronic start relay.

Applications

- Analytical instruments
- Centrifuges, ultra-high speed
- Coating
- Degassing/curing - oil, epoxy resin
- Distillation/extraction/filtration

Dimensions

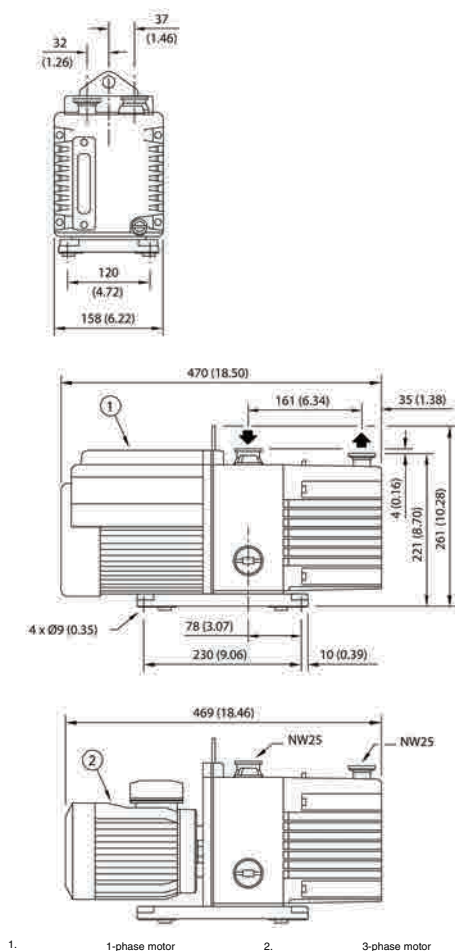

Performance Curves

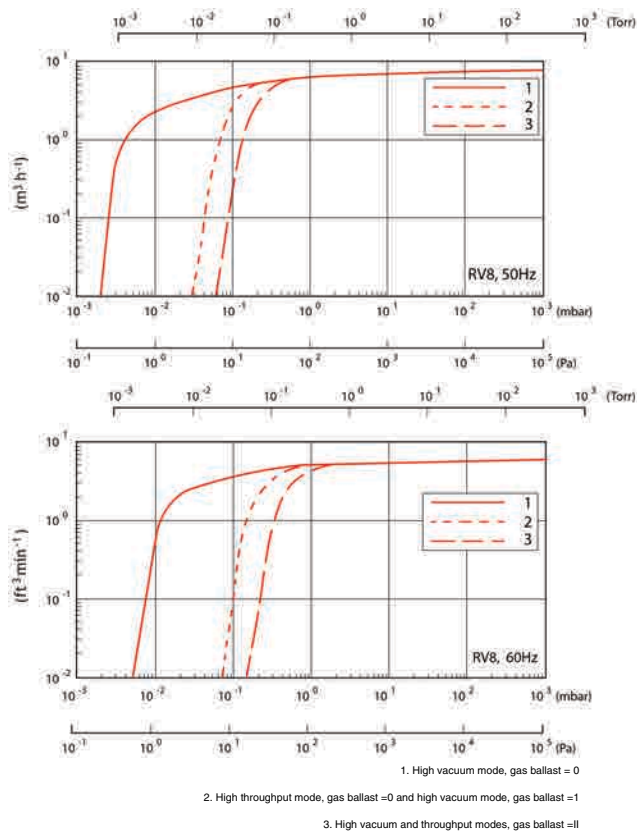

Technical Data

Displacement	
50Hz	$9.7 \text{ m}^3 \text{ h}^{-1} / 5.7 \text{ ft}^3 \text{ min}^{-1}$
60Hz	$11.7 \text{ m}^3 \text{ h}^{-1} / 6.9 \text{ ft}^3 \text{ min}^{-1}$
Speed (Pneurop 6602)	
50Hz	$8.5 \text{ m}^3 \text{ h}^{-1} / 5 \text{ ft}^3 \text{ min}^{-1}$
60Hz	$10 \text{ m}^3 \text{ h}^{-1} / 5.9 \text{ ft}^3 \text{ min}^{-1}$
Ultimate pressure	$2 \times 10^{-3} \text{ mbar} / 1.5 \times 10^{-3} \text{ Torr}$
Ultimate pressure GB I	$3 \times 10^{-2} \text{ mbar} / 2.3 \times 10^{-2} \text{ Torr}$
Ultimate pressure GB II	$6 \times 10^{-2} \text{ mbar} / 4.6 \times 10^{-2} \text{ Torr}$
Ultimate pressure with Fomblin®	$2 \times 10^{-2} \text{ mbar} / 1.5 \times 10^{-2} \text{ Torr}$
Max inlet pressure for water vapour	38 mbar / 28.5 Torr
Max water vapour pumping rate – GB I	60 gh^{-1}
Max water vapour pumping rate – GB II	220 gh^{-1}
Max allowed outlet pressure	1 bar gauge / 14 psig
Max allowed inlet and gas ballast pressure	0.5 bar gauge / 7 psig
Motor power 50/60Hz	450 / 550W
Power connector 1-ph	IEC EN60320 C13
Nominal rotation speed 50/60Hz	1500 / 1800rpm
Weight (without oil)	28 kg / 61.6 lb
Oil capacity min/max	0.45 / 0.75 litres
Recommended oil	Ultragrade 19
Inlet flange	NW25
Exhaust flange	NW25
Noise level	48 dB(A) @ 50 Hz
Operating temperature range	12 – 40 °C

Ordering Information

Product Description	Order No.
RV8 115/230V, 1-ph, 50/60Hz, Factory set to 230V for Europe	A65401903
RV8 100/200V, 1-ph, 50/60Hz, Factory set to 200V for Japan	A65401904
RV8 200-220/380-415V, 3-ph, 50Hz and 200-230/460V, 3-ph, 60Hz, Factory set to 380/460V	A65401905
RV8 115/230V, 1-ph, 50/60Hz, Factory set to 115V for USA	A65401906
PFPE RV8 115/230V, 1-ph, 50/60Hz, Factory set to 230V for Europe	A65409903
PFPE RV8 100/200V, 1-ph, 50/60Hz, Factory set to 200V for Japan	A65409904
PFPE RV8 200-220/380-415V, 3-ph, 50Hz, and 200-230/460V, 3-ph, 60Hz, Factory set to 380/460V	A65409905
PFPE RV8 115/230V, 1-ph, 50/60Hz, Factory set to 115V for Europe	A65409906
Accessories & Spares	Order No.
2m electrical supply cable for 1-ph pumps, UK, Three-pin plug	A50505000
2m electrical supply cable for 1-ph pumps, North European plug	A50506000
2m electrical supply cable for 1-ph pumps, North America/Japan plug	A50507000
2m electrical supply cable for 1-ph pumps, no plug	A50508000
RV gas-ballast adaptor	A50502000
Exhaust Nozzle Kit 3/4" To 15mm	A50509000
Model EMF10 mist filter	A46226000
Clean and overhaul kit	A65201131
Clean and overhaul kit (Nitrile)	A65201137
Spares Kit Blade RV8	A65401130
Outer Shaft Seal Kit RV	A65201134
Spares Kit Inlet Valve RV3/5/8/12	A65201036
Spares Kit Cartridge RV8	A65401032

RV12 Two Stage Rotary Vane Pump

Edwards RV pumps have become the industry standard for scientific primary pumping applications. RV pumps are uniquely capable of delivering high or low throughputs with high ultimate vacuum. This, combined with ultra-low noise levels, makes them ideal for a wide range of applications including GCMS and other small bench top type applications.

All pumps are approved to UL and CSA standards by an external test house. Edwards has a global network, providing world-wide support for product applications and service.

Supplied with: 1 litre of Ultragrade 19 oil, inlet filter and O-ring. Fomblin® must be purchased separately for PFPE RV pumps.



Features & Benefits

- 48 dB(A) and intrusive frequencies minimised.
- Dual mode. Suitable for high throughput and high vacuum applications.
- Easy-to-use gas ballast.
- Fast acting inlet valve for system protection.
- High torque, dual voltage/dual frequency motor, electronic start relay.

Applications

- Analytical instruments
- Centrifuges, ultra-high speed
- Coating
- Degassing/curing - oil, epoxy resin
- Distillation/extraction/filtration

Dimensions

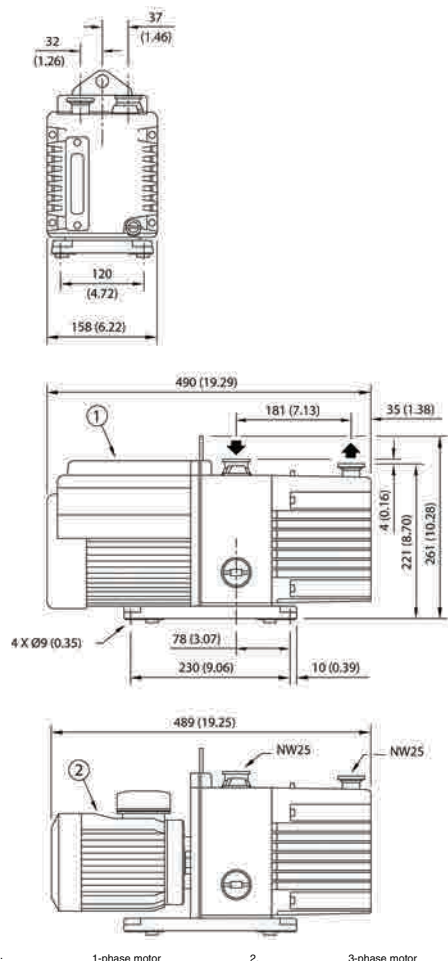

1. 1-phase motor 2. 3-phase motor

Performance Curves

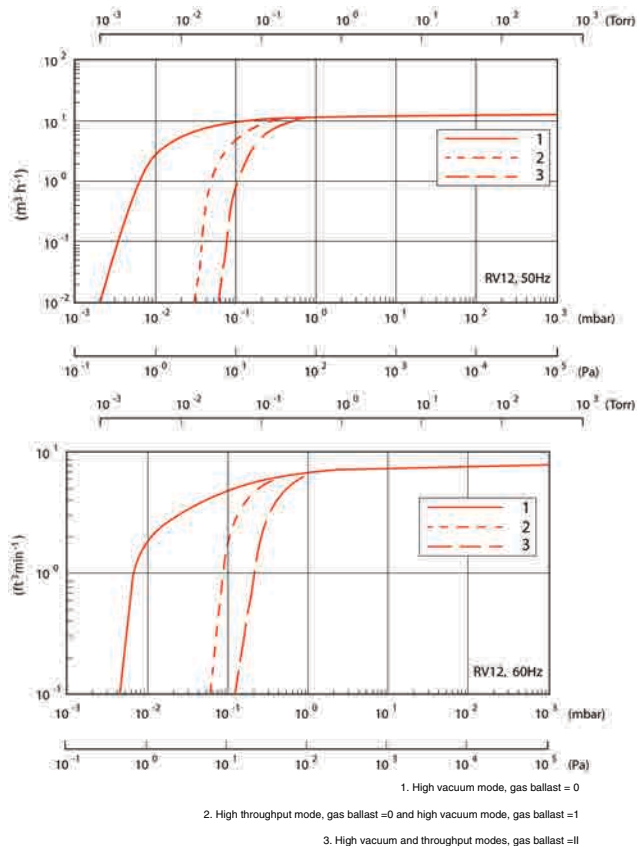

Technical Data

Displacement	
50Hz	14.2 m ³ h ⁻¹ / 8.4 ft ³ min ⁻¹
60Hz	17 m ³ h ⁻¹ / 10 ft ³ min ⁻¹
Speed (Pneurop 6602)	
50Hz	12 m ³ h ⁻¹ / 7.1 ft ³ min ⁻¹
60Hz	14.2 m ³ h ⁻¹ / 8.4 ft ³ min ⁻¹
Ultimate pressure	2 x 10 ⁻³ mbar / 1.5 x 10 ⁻³ Torr
Ultimate pressure GB I	3 x 10 ⁻² mbar / 2.3 x 10 ⁻² Torr
Ultimate pressure GB II	6 x 10 ⁻² mbar / 4.6 x 10 ⁻² Torr
Ultimate pressure with Fomblin®	2 x 10 ⁻² mbar / 1.5 x 10 ⁻² Torr
Max inlet pressure for water vapour	32 mbar / 24 Torr
Max water vapour pumping rate – GB I	60 gh ⁻¹
Max water vapour pumping rate – GB II	220 gh ⁻¹
Max allowed outlet pressure	1 bar gauge / 14 psig
Max allowed inlet and gas ballast pressure	0.5 bar gauge / 7 psig
Motor power 50/60Hz	450 / 550W
Power connector 1-ph	IEC EN60320 C13
Nominal rotation speed 50/60Hz	1500 / 1800rpm
Weight (without oil)	29 kg / 63.8 lb
Oil capacity min/max	0.65 / 1 litres
Recommended oil	Ultragrade 19
Inlet flange	NW25
Exhaust flange	NW25
Noise level	48 dB(A) @ 50 Hz
Operating temperature range	12 – 40 °C

Ordering Information

Product Description	Order No.
RV12 115/230V, 1-ph, 50/60Hz, Factory set to 230V for Europe	A65501903
RV12 100/200V, 1-ph, 50/60Hz, Factory set to 200V for Japan	A65501904
RV12 200-220/380-415V, 3-ph, 50Hz and 200-230/460V, 3-ph, 60Hz, Factory set to 380/460V	A65501905
RV12 115/230V, 1-ph, 50/60Hz, Factory set to 115V for USA	A65501906
PFPE RV12 115/230V, 1-ph, 50/60Hz, Factory set to 230V for Europe	A65509903
PFPE RV12 100/200V, 1-ph, 50/60Hz, Factory set to 200V for Japan	A65509904
PFPE RV12 200-220/380-415V, 3-ph, 50Hz and 200-230/460V, 3-ph, 60Hz, Factory set to 380/460V	A65509905
PFPE RV12 Two Stage Rotary Vane Pump 115/230V 1ph 50/60Hz, Factory set to 115V for USA	A65509906
Accessories & Spares	Order No.
2m electrical supply cable for 1-ph pumps, UK, Three-pin plug	A50505000
2m electrical supply cable for 1-ph pumps, North European plug	A50506000
2m electrical supply cable for 1-ph pumps, North America/Japan plug	A50507000
2m electrical supply cable for 1-ph pumps, no plug	A50508000
RV gas-ballast adaptor	A50502000
Exhaust Nozzle Kit 3/4" To 15mm	A50509000
Model EMF20 mist filter	A46229000
Clean and overhaul kit	A65201131
Clean and overhaul kit (Nitrile)	A65201137
Spares Kit Blade RV12	A65501130
Outer Shaft Seal Kit RV	A65201134
Spares Kit Inlet Valve RV3/5/8/12	A65201036
Spares Kit Cartridge RV12	A65501032

E1M18 One Stage, E2M18 Two Stage Rotary Vane Pumps



The EM range of oil-sealed rotary pumps - renowned for their high ultimate vacuum, rapid pumping speed, quiet operation and ability to handle vapour - have become the industry standard for laboratory and light industrial applications.

The E1M18 and E2M18 pumps are direct drive, sliding vane pumps. The pump is oil sealed and designed for reliable, long-term operation. The pump is a freestanding unit with the drive provided through a flexible coupling by either a single-phase or three-phase (four-pole) motor.



Supplied with: Ultragrade 19 oil, NW25 O-ring and centering ring. Fomblin® must be purchased separately for PFPE pumps.

Features & Benefits

- The pump is designed for reliable, long-term operation.
- Thermal overload device prevents overheating (single phase only).
- The drive is provided through a flexible coupling by a single-phase or three-phase (four pole) motor.
- The motors are totally enclosed and are cooled by the motor-cooling fan.
- Pressure die cast oil box with integral oil seals prevents oil leaks.

Applications

- Analytical instruments
- Leak detectors, Helium
- Research and development
- Backing Turbomolecular pumps

Dimensions

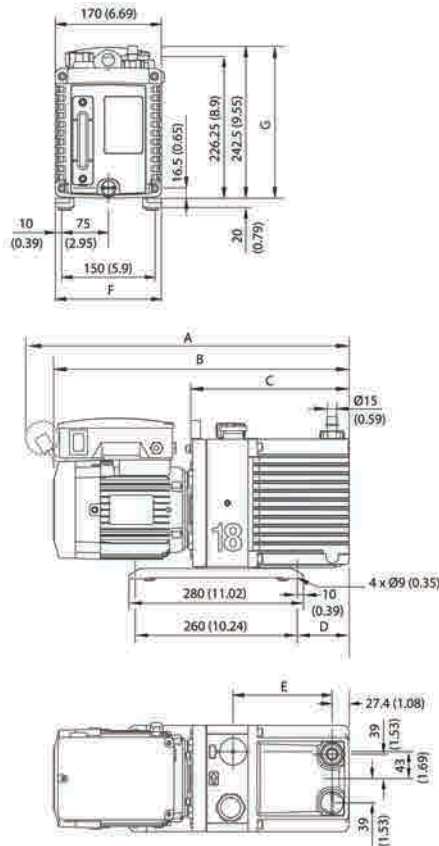

Order No.	A	B	C	D	E	F	G
A34310940	-	474	247	83	159	171.4	217
A34315904	518	474	247	83	159	171.4	241
A34317984	-	504	247	83	159	171.4	251
A36310940	-	520	295	131	207	171.4	217
A36315904	564	520	295	131	207	171.4	241
A36317984	-	550	295	131	207	171.4	251

Performance Curves

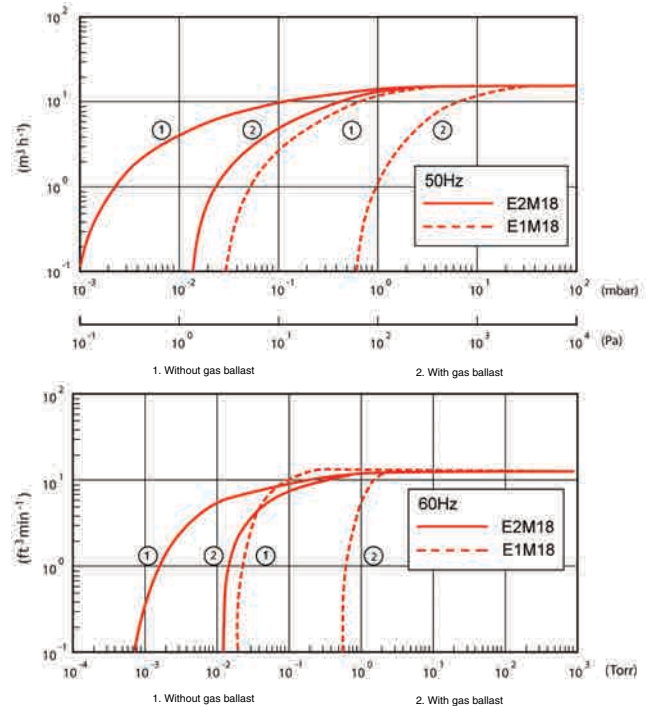

Technical Data

	E1M18	E2M18
Displacement		
50Hz	20.5 m ³ h ⁻¹ / 12.1 ft ³ min ⁻¹	20.5 m ³ h ⁻¹ / 12.1 ft ³ min ⁻¹
60Hz	25.0 m ³ h ⁻¹ / 14.7 ft ³ min ⁻¹	25.0 m ³ h ⁻¹ / 14.7 ft ³ min ⁻¹
Speed (Pneurop 6602)		
50Hz	17.0 m ³ h ⁻¹ / 10 ft ³ min ⁻¹	17.0 m ³ h ⁻¹ / 10 ft ³ min ⁻¹
60Hz	20.4 m ³ h ⁻¹ / 12.1 ft ³ min ⁻¹	20.4 m ³ h ⁻¹ / 12.1 ft ³ min ⁻¹
Ultimate vacuum (total pressure)		
without gas purge	3 x 10 ⁻² mbar / 2.2 x 10 ⁻² Torr	1 x 10 ⁻³ mbar / 7.4 x 10 ⁻⁴ Torr
with gas purge	6.5 x 10 ⁻¹ mbar / 4.8 x 10 ⁻¹ Torr	1.5 x 10 ⁻¹ mbar / 1.1 x 10 ⁻² Torr
with Fomblin®	3 x 10 ⁻¹ mbar / 2.56 x 10 ⁻² Torr	1 x 10 ⁻² mbar / 7.5 x 10 ⁻³ Torr
Inlet connection	NW25 Nozzle 15 mm external Ø removable from 3/4 in BSP tapped hole	NW25 Nozzle 15 mm external Ø removable from 3/4 in BSP tapped hole
Outlet connection*		
Max permitted pressure at outlet	0.5 bar gauge / 7 psig	0.5 bar gauge / 7 psig
Max inlet pressure for water vapour	50 mbar / 38 Torr	20 mbar / 15 Torr
Max water vapour pumping rate	0.65 kg h ⁻¹	0.3 kg h ⁻¹
Operating temp range	13-40°C	13 – 40 °C
Nominal Rotation speed 50/60Hz	1440/1720 rpm	1440 / 1720 rpm
Power connector 1-ph**	IEC EN60320 C19	IEC EN60320 C19
Motor power 50 Hz	0.55 kW	0.55 kW
Motor power 60 Hz	0.75 kW	0.75 kW
Weight	37 kg / 82 lbs	39 kg / 86 lbs
Noise @ 50Hz	57 dB(A)	57 dB(A)
Oil capacity - max	1.4 litre	1.05 litre
Oil capacity - min	0.9 litre	0.75 litre
Recommended oil (supplied)	Ultragrade 19	Ultragrade 19

* The PFPE are supplied with NW25 outlet connection

** Pumps listed with IEC connector only

Ordering Information

Product Description	Order No.
E1M18 200-230/380-415V, 3-ph, 50Hz or 200-230/460V, 3-ph, 60Hz	A34310940
E1M18 100/200V, 1-ph, 50Hz or 100-105/200-210V, 1-ph, 60Hz	A34315904
E1M18 115/200-230V, 1-ph, 50/60Hz with IEC60320 connector, factory set to 230V	A34317984
E1M18 PFPE 115/200-230V, 1-ph, 50/60Hz with IEC60320 connector	A34325984
E2M18 200-230/380-415V, 3-ph, 50Hz or 200-230/460V, 3-ph, 60Hz	A36310940
E2M18 100/200V, 1-ph, 50Hz or 100-105/200-210V, 1-ph, 60Hz	A36315904
E2M18 115/200-230V, 1-ph, 50/60Hz with IEC60320 connector	A36317984
E2M18 PFPE 200-230/380-415 V, 3-ph, 50 Hz or 200-230/460 V, 3-ph, 60 Hz	A36321940
E2M18 PFPE 100/200V, 1-ph, 50Hz or 100-105/200-210V, 1-ph, 60Hz	A36325904
E2M18 PFPE 115/200-230 V, 1-ph, 50/60 Hz with IEC60320 connector fitted	A36325984
Accessories & Spares	Order No.
Model EMF20 mist filter	A46229000
2m Electrical supply cable, UK, three-pin plug	A50505003
2m Electrical supply cable, North European plug	A50506003
2m Electrical supply cable, North America/Japan plug	A50507003
2m Electrical supply cable, no plug	A50508003
Spares Kit C&O E1M18/E2M18	A36301131
Spares Kit Blade E1M18	A34301041
Spares Kit Blade E2M18	A36301020
NW25 to 28mm bore tube adaptor	C10520201
3/4" BSP to NW25 outlet adaptor	C10501414

E2M28 Two Stage Rotary Vane Pump

The EM range of oil-sealed rotary pumps - renowned for its high ultimate vacuum, rapid pumping speed, quiet operation and ability to handle vapour - has become the industry standard laboratory and light industrial applications.

The E2M28 pump is a two-stage, direct drive, sliding vane pump. The pump is oil sealed and designed for reliable, long-term operation in both laboratory and industrial environments. The pump is a freestanding unit with the drive provided through a flexible coupling by either a single-phase or three-phase (four-pole) motor.



Supplied with: Ultragrade 19 oil, NW25 O-ring and centering ring, lifting plate. Fomblin® must be purchased separately for PFPE pumps.

Features & Benefits

- The pump is designed for reliable, long-term operation.
- Thermal overload device prevents overheating (single phase only).
- The pump is a free-standing unit.
- The drive is provided through a flexible coupling by a single-phase or three-phase (four pole) motor.
- The motors are totally enclosed and are cooled by the motor-cooling fan.

Applications

- Analytical instruments - LCMS
- Automotive
- Beam lines and high energy physics
- Centrifuges, ultra-high speed
- Coating

Dimensions

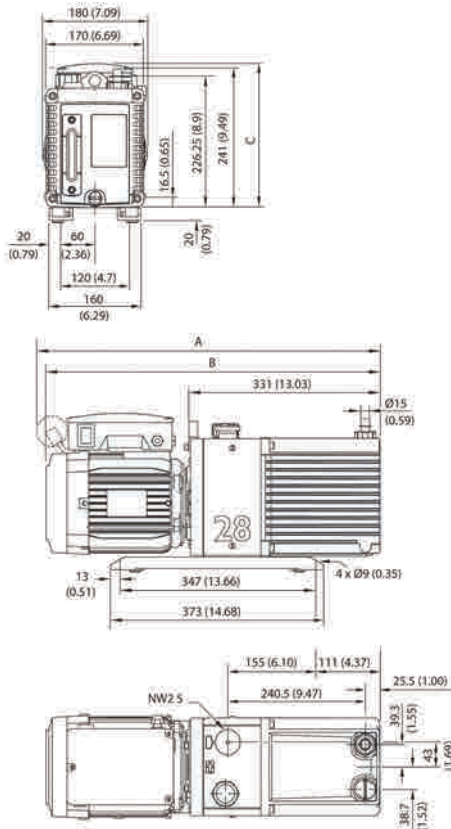

Ordering No.	A	B	C
A37310940	-	553	217
A37315904	598	584	251
A37317984	-	584	251

Performance Curves

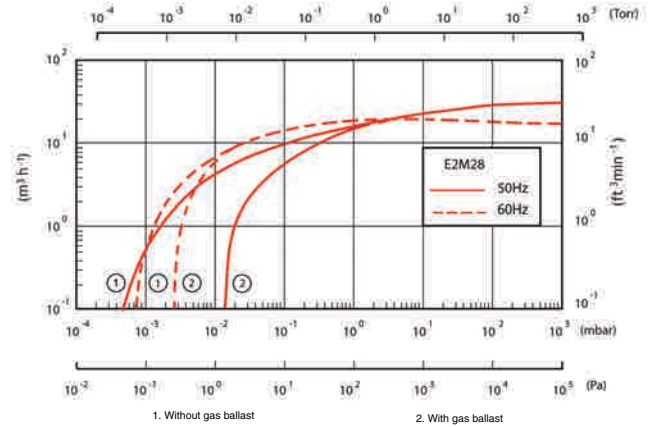

Technical Data

Displacement (swept volume)	
50 Hz	32.2 m ³ h ⁻¹ / 19 ft ³ min ⁻¹
60 Hz	38.9 m ³ h ⁻¹ / 22.3 ft ³ min ⁻¹
Speed (Pneurop 6602)	
50 Hz	27.5 m ³ h ⁻¹ / 16.2 ft ³ min ⁻¹
60 Hz	33.0 m ³ h ⁻¹ / 19.5 ft ³ min ⁻¹
Ultimate vacuum (total pressure)	
without gas ballast	1 x 10 ⁻³ mbar / 7.5 x 10 ⁻⁴ Torr
with gas ballast	1.5 x 10 ⁻² mbar / 1.1 x 10 ⁻² Torr
with Fomblin®	1 x 10 ⁻² mbar / 7.5 x 10 ⁻³ Torr
Inlet connection	NW25 flange
Outlet connection*	Nozzle 15 mm external Ø removable from 3/4 in BSP tapped hole
Max allowed pressure at outlet	0.5 bar gauge / 7 psig
Max inlet pressure for water vapour	30 mbar / 23 Torr
Max water vapour pumping rate	0.7 kg h ⁻¹
Operating temperature range	13 – 40 °C
Nominal rotation speed	1440 / 1720 rpm
Motor power 50 Hz	0.75 kW
Motor power 60 Hz	0.90 kW
Power Connector 1-ph**	IEC EN60320 C19
Weight	44 kg / 97 lbs
Noise	57 dB(A) @ 50 Hz
Oil capacity - max	1.5 litre
Oil capacity - min	1.2 litre
Recommended oil (supplied)	Ultragrade 19

* The PFPE are supplied with NW25 outlet connection

** Pumps listed with IEC connector only

Ordering Information

Product Description	Order No.
E2M28 200-220/380-415 V, 3-ph, 50 Hz or 200-230/460 V, 3-ph, 60 Hz IE2	A37330940
E2M28 100/200 V, 1-ph, 50 Hz or 100-105/200-210 V, 1-ph, 60 Hz	A37315904
E2M28 115/200-230 V, 1-ph, 50/60 Hz with IEC60320 connector fitted	A37317984
E2M28 PFPE 200-220/380-415 V, 3-ph, 50 Hz or 200-230/460 V, 3-ph, 60 Hz IE2	A37341940
E2M28 PFPE 115/200-230 V, 1-ph, 50/60 Hz with IEC60320 connector fitted	A37325984
Accessories & Spares	Order No.
Model MF30 mist filter	A46233000
Model EMF20 mist filter	A46229000
2m Electrical supply cable, UK, three-pin plug	A50505003
2m Electrical supply cable, North European plug	A50506003
2m Electrical supply cable, North America/Japan plug	A50507003
2m Electrical supply cable, no plug	A50508003
Clean and overhaul kit (hydrocarbon) E2M28	A37301131
Blade Kit E2M28/30	A37301135
NW25 to 28mm bore tube adaptor	C10520201
3/4" BSP to NW25 outlet adaptor	C10501414

RV ATEX Two Stage Rotary Vane Pump

ATEX RV pumps have an **external** ATEX classification of Ex II 2G IIC T4 or Ex II 2G IIB T4 and are suitable for use in potentially explosive atmospheres. They share the same **internal** ATEX classification as our standard RV pumps, namely Ex II 3G c IIB T4. ATEX pumps with flameproof motors require the user to provide 2 off hazardous area cable glands and cables. In addition, connection of the thermistors to an appropriate safety circuit must be made to switch off the pump if overheating occurs. The pumps are supplied with the Gas Ballast port plugged. When pumping flammable gasses or vapours you must fit an inert gas purge to this port to dilute such gases or vapours below the lower explosive limit. Supplied with 1 litre of Ultragrade 19 oil, inlet filter and O-ring.



Features & Benefits

- ATEX rated spot voltage motor.
- Dual mode. Suitable for high throughput and high vacuum applications.
- Fast acting inlet valve for system protection.
- Efficient high pressure lubrication.
- Oil-tight with printed gaskets, effective shaft seals.

Dimensions

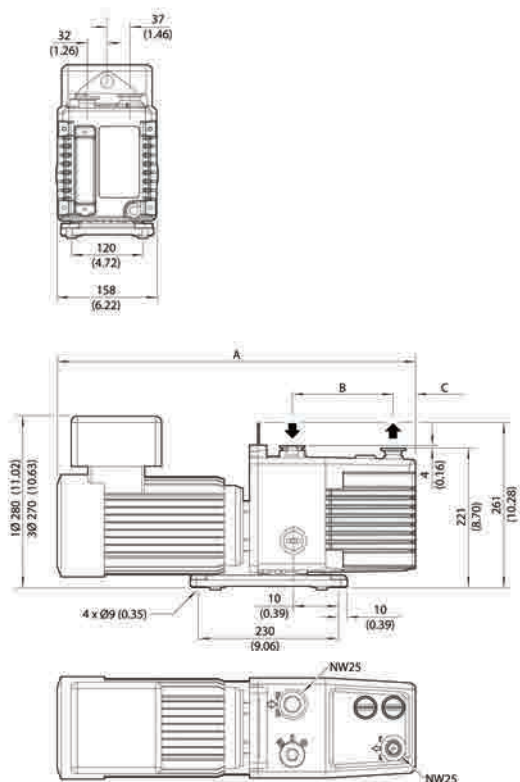

Pump	A	B	C
RV3	520 (20.47)	127 (5)	29 (1.06)
RV5	520 (20.47)	127 (5)	29 (1.06)
RV8	560 (22.05)	161 (6.34)	35 (1.38)
RV12	580 (22.83)	181 (7.13)	35 (1.38)

Applications

- Hazardous area pumping

Performance Curves

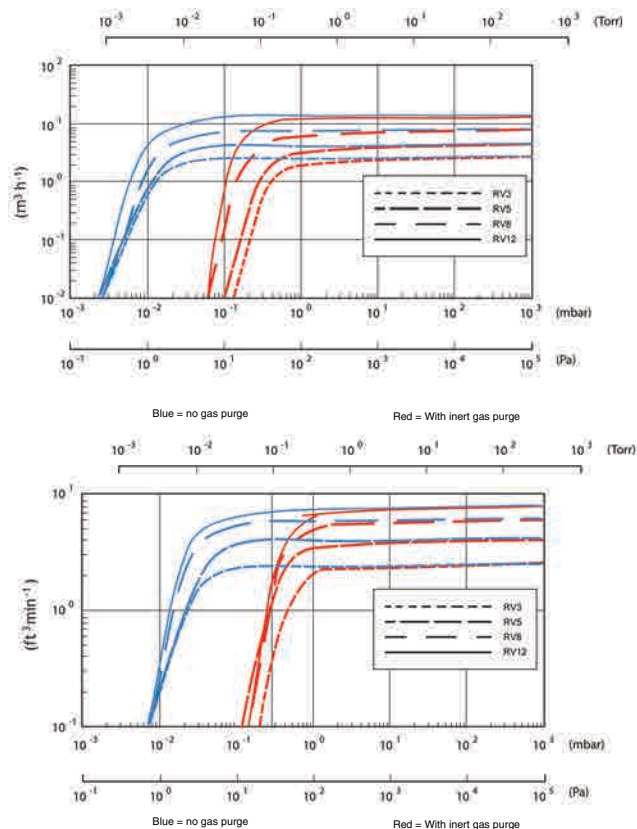

Technical Data

Displacement	
RV3 50Hz	3.7 m ³ h ⁻¹ / 2.2 ft ³ min ⁻¹
RV3 60Hz	4.5 m ³ h ⁻¹ / 2.6 ft ³ min ⁻¹
RV5 50Hz	5.8 m ³ h ⁻¹ / 3.4 ft ³ min ⁻¹
RV5 60Hz	7 m ³ h ⁻¹ / 4.1 ft ³ min ⁻¹
RV8 50Hz	9.7 m ³ h ⁻¹ / 5.7 ft ³ min ⁻¹
RV8 60Hz	11.7 m ³ h ⁻¹ / 6.9 ft ³ min ⁻¹
RV12 50Hz	14.2 m ³ h ⁻¹ / 8.4 ft ³ min ⁻¹
RV12 60Hz	17 m ³ h ⁻¹ / 10 ft ³ min ⁻¹
Speed (Pneurop 6602)	
RV3 50Hz	3.3 m ³ h ⁻¹ / 2 ft ³ min ⁻¹
RV3 60Hz	3.9 m ³ h ⁻¹ / 2.3 ft ³ min ⁻¹
RV5 50Hz	5.1 m ³ h ⁻¹ / 3 ft ³ min ⁻¹
RV5 60Hz	6.2 m ³ h ⁻¹ / 3.6 ft ³ min ⁻¹
RV8 50Hz	8.5 m ³ h ⁻¹ / 5 ft ³ min ⁻¹
RV8 60Hz	10 m ³ h ⁻¹ / 5.9 ft ³ min ⁻¹
RV12 50Hz	12 m ³ h ⁻¹ / 7.1 ft ³ min ⁻¹
RV12 60Hz	14.2 m ³ h ⁻¹ / 8.4 ft ³ min ⁻¹
Max allowed outlet pressure	1 bar gauge / 14 psig
Max allowed inlet and gas purge pressure	0.5 bar gauge / 7 psig
Nominal rotation speed 50/60Hz	1430 / 1710 rpm
Motor power 50/60Hz	550W
Weight (without oil)	
RV3	28 kg / 61.6 lb
RV5	28 kg / 61.6 lb
RV8	31 kg / 68.2 lb
RV12	32 kg / 70.4 lb
Inlet flange	NW25
Exhaust flange	NW25
Operating temperature range	12 – 40 °C

Ordering Information

Product Description	Order No.
ATEX RV3 115V, 1-ph 50Hz Ex II 2G IIC T4	A65218985
ATEX RV3 115V, 1-ph, 60Hz Ex II 2G IIC T4	A65218986
ATEX RV3 115V, 1-ph, 60Hz Ex II 2G IIB T4	A65218987
ATEX RV3 230V, 1-ph, 60Hz Ex II 2G IIB T4	A65218988
ATEX RV3 230V, 1-ph, 50Hz Ex II 2G IIC T4	A65218989
ATEX RV3 230V, 1-ph, 60Hz Ex II 2G IIC T4	A65218990
ATEX RV3 230V, 1-ph, 50Hz Ex II 2G IIB T4	A65218991
ATEX RV3 400V, 3-ph, 50Hz Ex II 2G IIC T4	A65218992
ATEX RV3 400V, 3-ph, 50Hz Ex II 2G IIB T4	A65218993
ATEX RV5 115V, 1-ph 50Hz Ex II 2G IIC T4	A65318985
ATEX RV5 115V, 1-ph, 60Hz Ex II 2G IIC T4	A65318986
ATEX RV5 115V, 1-ph, 60Hz Ex II 2G IIB T4	A65318987
ATEX RV5 230V, 1-ph, 60Hz Ex II 2G IIB T4	A65318988
ATEX RV5 230V, 1-ph, 50Hz Ex II 2G IIC T4	A65318989
ATEX RV5 230V, 1-ph, 60Hz Ex II 2G IIC T4	A65318990
ATEX RV5 230V, 1-ph, 50Hz Ex II 2G IIB T4	A65318991
ATEX RV5 400V, 3-ph, 50Hz Ex II 2G IIC T4	A65318992
ATEX RV5 400V, 3-ph, 50Hz Ex II 2G IIB T4	A65318993
ATEX RV8 115V, 1-ph 50Hz Ex II 2G IIC T4	A65418985
ATEX RV8 115V, 1-ph, 60Hz Ex II 2G IIC T4	A65418986
ATEX RV8 115V, 1-ph, 60Hz Ex II 2G IIB T4	A65418987
ATEX RV8 230V, 1-ph, 60Hz Ex II 2G IIB T4	A65418988
ATEX RV8 230V, 1-ph, 50Hz Ex II 2G IIC T4	A65418989
ATEX RV8 230V, 1-ph, 60Hz Ex II 2G IIC T4	A65418990
ATEX RV8 230V, 1-ph, 50Hz Ex II 2G IIB T4	A65418991
ATEX RV8 400V, 3-ph, 50Hz Ex II 2G IIC T4	A65418992
ATEX RV8 400V, 3-ph, 50Hz Ex II 2G IIB T4	A65418993
ATEX RV12 115V, 1-ph, 60Hz Ex II 2G IIC T4	A65518986
ATEX RV12 115V, 1-ph, 60Hz Ex II 2G IIB T4	A65518987
ATEX RV12 230V, 1-ph, 60Hz Ex II 2G IIB T4	A65518988
ATEX RV12 230V, 1-ph, 50Hz Ex II 2G IIC T4	A65518989
ATEX RV12 230V, 1-ph, 60Hz Ex II 2G IIC T4	A65518990
ATEX RV12 230V, 1-ph, 50Hz Ex II 2G IIB T4	A65518991
ATEX RV12 400V, 3-ph, 50Hz Ex II 2G IIC T4	A65518992
ATEX RV12 400V, 3-ph, 50Hz Ex II 2G IIB T4	A65518993

E1M18 One Stage, E2M18 Two Stage ATEX Rotary Vane Pumps

ATEX EM18 pumps have an **external** ATEX classification of Ex II 2G IIC T4 or Ex II 2G IIB T4 and are suitable for use in potentially explosive atmospheres. They share the same **internal** ATEX classification as our standard EM18 pumps, namely Ex II 3G c IIB T4. ATEX pumps with flameproof motors require the user to provide 2 off hazardous area cable glands and cables. In addition, connection of the thermistors to an appropriate safety circuit must be made to switch off the pump if overheating occurs. The pumps are supplied with the gas ballast port plugged. When pumping flammable gasses or vapours you must fit and inert gas purge to this port to dilute such gasses or vapours below the lower explosive limit. Supplied with ultragrade 19 oil, NW25 O-ring and centering ring.



Features & Benefits

- Approved to external ATEX standards Ex II 2G IIC T4 and Ex II 2G IIB T4, which enables use in hazardous environments.

Dimensions

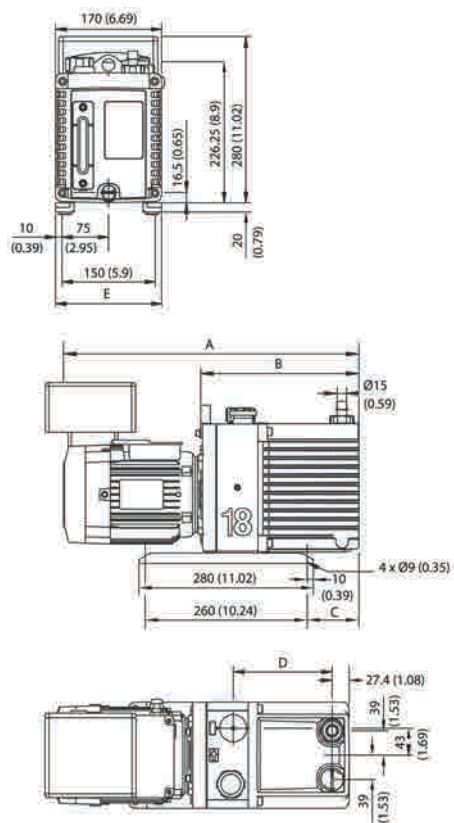

	A	B	C	D	E
E1M18	526	247	83	159	171.4
E2M18	576	295	131	207	171.4

Applications

- Hazardous area pumping

Performance Curves

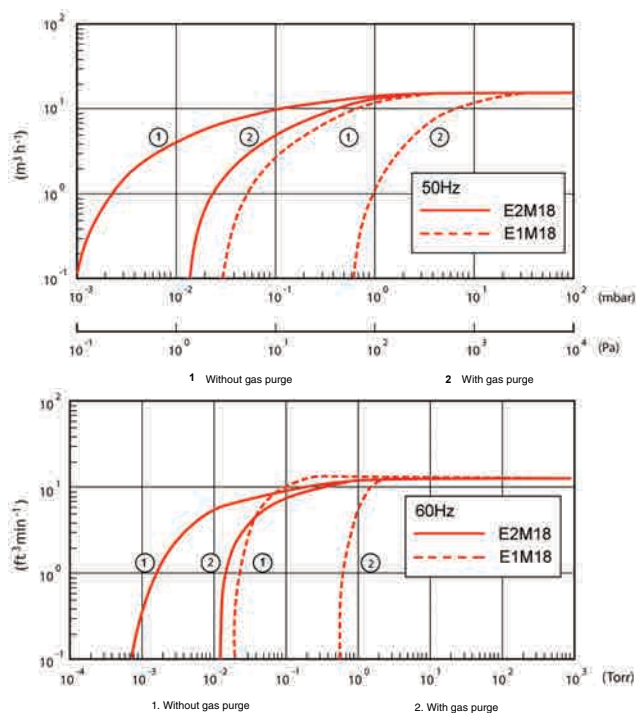

Technical Data

Ordering Information

1

Page
40

	E1M18	E2M18
Displacement		
50Hz	20.5 m ³ h ⁻¹ / 12.1 ft ³ min ⁻¹	20.5 m ³ h ⁻¹ / 12.1 ft ³ min ⁻¹
60Hz	25.0 m ³ h ⁻¹ / 14.7 ft ³ min ⁻¹	25.0 m ³ h ⁻¹ / 14.7 ft ³ min ⁻¹
Speed (Pneurop 6602)		
50 Hz	17.0 m ³ h ⁻¹ / 10 ft ³ min ⁻¹	17.0 m ³ h ⁻¹ / 10 ft ³ min ⁻¹
60Hz	20.4 m ³ h ⁻¹ / 12.1 ft ³ min ⁻¹	20.4 m ³ h ⁻¹ / 12.1 ft ³ min ⁻¹
Ultimate vacuum (total pressure)		
without gas purge	3 x 10 ⁻² mbar / 2.2 x 10 ⁻² Torr	1 x 10 ⁻³ mbar / 7.4 x 10 ⁻⁴ Torr
with gas purge	6.5 x 10 ⁻¹ mbar / /4.8 x 10 ⁻¹ Torr	1.5 x 10 ⁻¹ mbar / /1.1 x 10 ⁻² Torr
Inlet connection	Nozzle 15 mm external Ø removable from 3/4 in BSP tapped hole	Nozzle 15 mm external Ø removable from 3/4 in BSP tapped hole
Outlet connection		
Max permitted pressure at outlet	0.5 bar gauge / 7 psig	0.5 bar gauge / 7 psig
Max inlet pressure for water vapour	50 mbar / 38 Torr	20 mbar / 15 Torr
Max water vapour pumping rate	0.65 kg h ⁻¹	0.3 kg h ⁻¹
Operating temp range	13-40°C	13-40°C
Nominal Rotation speed 50/60Hz	1440/1720 rpm	1440/1720 rpm
Motor power		
50 Hz	0.55 kW	0.55 kW
60 Hz	0.75 kW	0.75 kW
Weight	37 kg / 82 lbs	39 kg / 86 lbs
Noise @ 50Hz	57 dB(A)	57 dB(A)
Oil capacity - max	1.4 litre	1.05 litre
Oil capacity - min	0.9 litre	0.75 litre
Recommended oil (supplied)	Ultragrade 19	Ultragrade 19

Product Description	Order No.
E1M18 ATEX 230V, 1ph, 50Hz Ex II 2G IIB T4	A34318991
E1M18 ATEX 230V, 1ph, 50Hz Ex II 2G IIC T4	A34318989
E1M18 ATEX 400V, 3ph, 50Hz Ex II 2G IIB T4	A34318993
E1M18 ATEX 400V, 3ph, 50Hz Ex II 2G IIC T4	A34318992
E1M18 ATEX 115V, 1ph, 60Hz Ex II 2G IIB T4	A34318987
E1M18 ATEX 115V, 1ph, 60Hz Ex II 2G IIC T4	A34318986
E1M18 ATEX 230V, 1ph, 60Hz Ex II 2G IIB T4	A34318988
E1M18 ATEX 230V, 1ph, 60Hz Ex II 2G IIC T4	A34318990
E2M18 ATEX 230V, 1ph, 50Hz Ex II 2G IIB T4	A36318991
E2M18 ATEX 230V, 1ph, 50Hz Ex II 2G IIC T4	A36318989
E2M18 ATEX 400V, 1ph, 50Hz Ex II 2G IIB T4	A36318993
E2M18 ATEX 400V, 1ph, 50Hz Ex II 2G IIC T4	A36318992
E2M18 ATEX 115V, 1ph, 60Hz Ex II 2G IIB T4	A36318987
E2M18 ATEX 115V, 1ph, 60Hz Ex II 2G IIC T4	A36318986
E2M18 ATEX 230V, 1ph, 60Hz Ex II 2G IIB T4	A36318988
E2M18 ATEX 230V, 1ph, 60Hz Ex II 2G IIC T4	A36318990
Accessories & Spares	Order No.
3/4" BSP to NW25 outlet adaptor	C10501414
NW25 O Ring Viton Pk 5	H02124035
NW25 to 28mm bore tube adaptor	C10520201
NW25/25 Centring Nitrile S/S Pk1	C10514396
Ultragrade 19 Oil	H11025013
Spares Kit Blade E1M18	A34301041
Spares Kit C&O E1M18/E2M18	A36301131

The table shows current data and suggests a suitable fuse rating. Starting current is drawn for less than one second and slow blow fuses should be used to prevent unnecessary rupture during starting. Pump outflows are rated for operation above 12°C. Pump starting at temperatures lower than 12°C will increase the current drawn due to the higher start torque required. This may cause the motor thermal overload to trip.

Three-phase motors should be protected by a starter consisting of a suitably rated contactor and thermal overload. The trip current regulator on the thermal overload should be set according to the starter manufacturer's instructions.

Electrical Supply	Full load current (A)		Start current (A)		Suggested fuse rating (A)
	50 Hz	60 Hz	50 Hz	60 Hz	
E2M0.7					
200-240 V 1-ph 50/60 Hz	1.0	1.0	2.8	2.3	6
100-120 V 1-ph 50/60 Hz	1.8	1.9	5.7	5.3	10
E2M1.5					
200-240 V 1-ph 50/60 Hz	1.4	1.3	5.5	5.2	6
100-120 V 1-ph 50/60 Hz	3.1	2.6	12.0	11.2	10
RV3 and RV5					
220-240 V 1-ph 50/60 Hz	2.7	2.1	17.0	17.0	5
110-120 V 1-ph 50/60 Hz	4.4	4.4	30.8	30.8	10
200 V 1-ph 50/60 Hz	2.9	2.4	17.6	17.2	5
200-220 V 3-ph 50/60 Hz	1.7	1.7	10.2	10.2	2.5
380-415/460 V 3-ph 50/60 Hz	1.0	1.0	5.7	7.0	2.5
RV8 and RV12					
220-240 V 1-ph 50/60 Hz	3.4	3.4	17.0	18.0	5
110-120 V 1-ph 50/60 Hz	7.8	6.9	34.0	30.8	13
200 V 1-ph 50/60 Hz	4.0	4.0	17.6	17.2	5
200-220 V 3-ph 50/60 Hz	2.5	2.9	14.0	12.0	4.0
380-415/460 V 3-ph 50/60 Hz	1.5	1.5	9.0	8.7	2.5
E1M18 and E2M18					
220-240 V 1-ph 50/60 Hz	4.6	5.0	33.0	33.0	15
110-120 V 1-ph 50/60 Hz	11.0	10.0	42.0	32.0	30
200 V 1-ph 50/60 Hz	6.0	5.5	44.0	44.0	15
100 V 1-ph 50/60 Hz	12.0	11.0	88.0	88.0	30
200-230 V 3-ph 50/60 Hz	3.3	2.3	16.1	15.9	10
380-415/460 V 3-ph 50/60 Hz	1.9	1.6	10.2	10.6	6
E2M28					
220-240 V 1-ph 50/60 Hz	6.0	6.5	27.0	32.0	15
110-120 V 1-ph 50/60 Hz	12.0	12.0	36.0	50.0	30
200 V 1-ph 50/60 Hz	6.5	5.5	40.0	40.0	20
100 V 1-ph 50/60 Hz	12.0	12.0	80.0	80.0	30
200-230 V 3-ph 50/60 Hz	3.8	3.9	22.8	22.0	16
380-415/460 V 3-ph 50/60 Hz	2.3	2.3	14.3	14.6	10
XDS35i					
200-230 V 1-ph 50/60 Hz	6.6	6.6	-	-	16 (13 UK)
100-120 V 1-ph 50/60 Hz	10.6	10.6	-	-	20
XDS46i and XDS100B					
200-230 V 1-ph 50/60 Hz	6.6	6.6	-	-	16 (13 UK)
100-120 V 1-ph 50/60 Hz	10.6	10.6	-	-	20
nXDS					
100-127 V 1-ph 50/60 Hz	10.0	10.0	-	-	13
200-240 V 1-ph 50/60 Hz	6.0	6.0	-	-	10

This diagram shows the accessories available for oil-sealed pumps. Refer to the following pages for details of each accessory. Note that the E-LAB2 pump is supplied with all required accessories.

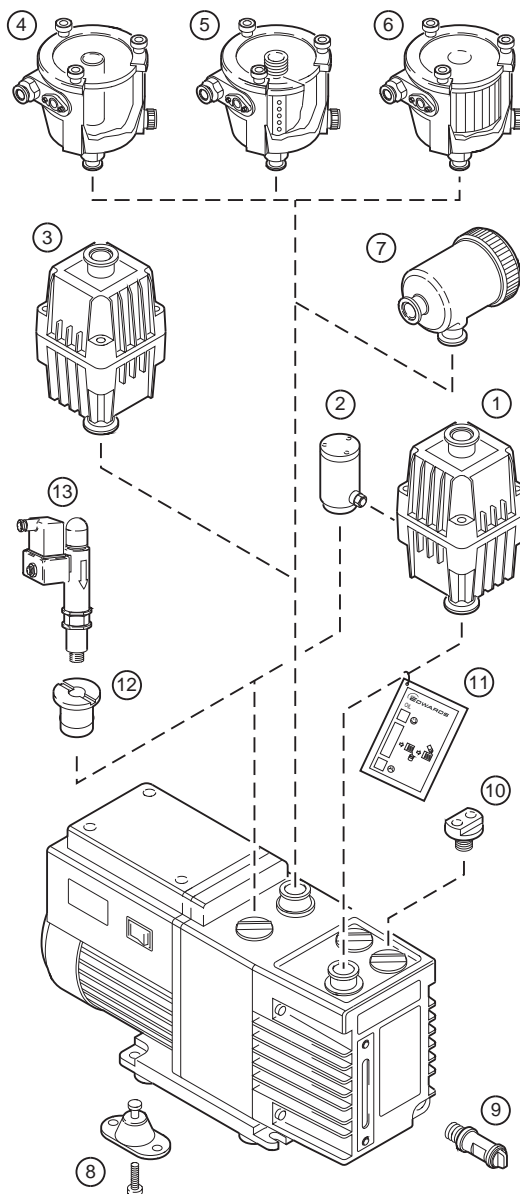

- 1 Outlet mist filter*
- 2 Oil return kit†
- 3 Small volume inlet liquid catchpot
- 4 ITO20K inlet liquid catchpot
- 5 ITC20K inlet chemical trap
- 6 ITF20K inlet dust filter
- 7 FL20K foreline trap
- 8 Vibration isolators
- 9 Oil drain kit‡
- 10 OB20 oil box purge adaptor
- 11 Oil change reminder card
- 12 RV gas ballast adaptor**
- 13 RV gas solenoid operated gas ballast valve

* EMF filter shown
 † RV adjustable gas ballast oil return kit shown
 ‡ RV pump extension kit shown
 ** Not required for EM pumps

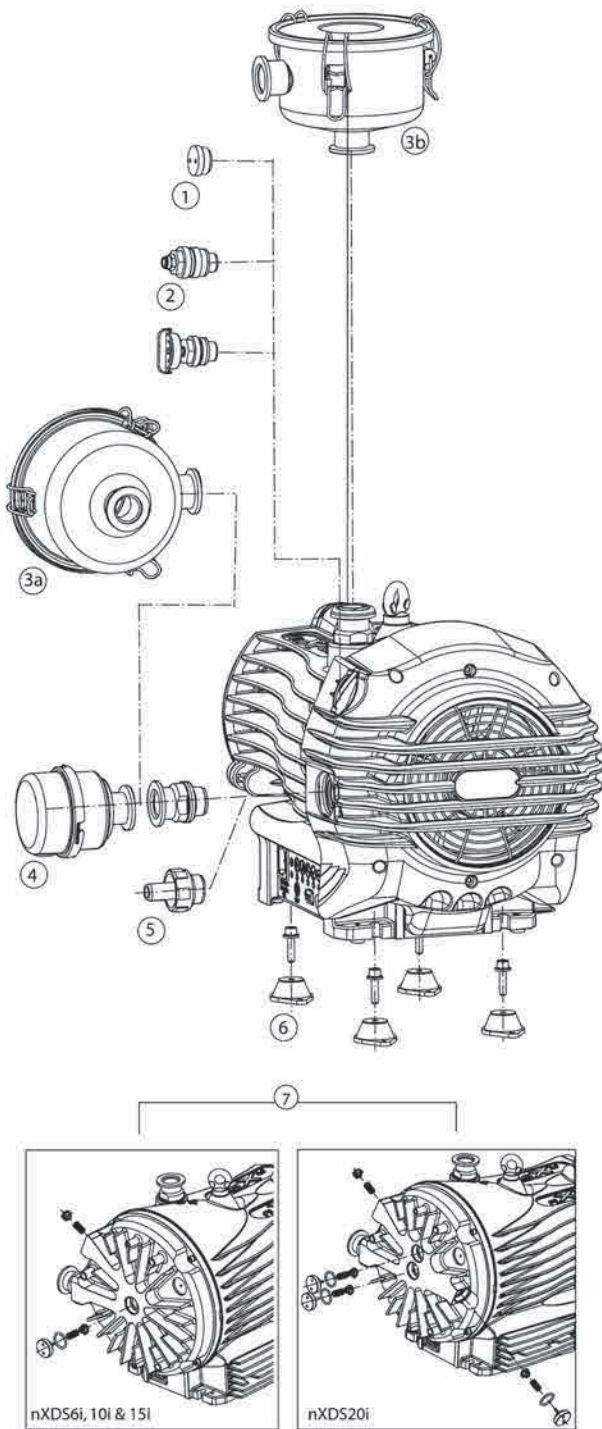

- | | |
|-----------------------------|--|
| 1 Gas-ballast adaptor blank | 5 Exhaust nozzle |
| 2 Gas-ballast adaptor | 6 Vibration isolators |
| 3a Inlet / exhaust filter | 7 Chemical resistance conversion kit |
| 3b Inlet / exhaust filter | 8 Pump-to-controller cable (not shown) |
| 4 Silencer | |

* General view (O-ring seals not shown)

Outlet Mist Filters

Benefits of the mist filter include:

- Protection from oil mist emissions as required by COSHH and health and safety regulations
- Use of optional oil return kits results in reduced oil level maintenance and savings in pump oil
- If the oil element becomes blocked, an integral pressure relief valve opens

EMF Filters The EMF3, EMF10 and EMF20 mist filters are suitable for all small rotary vane pumps up to E2M18. (The EMF20 can be used with an E2M28 on low pressure/throughput applications; contact Edwards). They are very efficient at 99.999% DOP test and are also azide proof. The white bottom half of the body is semi-transparent, allowing the oil level to be monitored. The EMF filters have a unique odour element which neutralizes the smell of oil mist.

MF30 Filter The MF30 is suitable for E2M28 pumps. It is very efficient at 99.85% DOP test. You can monitor the oil level through the sight-glass provided.

Dimensions

EMF Filters

	A	B Square	Inlet/ Outlet
EMF3	128 mm / 5.03 inch	82 mm / 3.22 inch	NW10
EMF10	171 mm / 6.73 inch	97 mm / 3.81 inch	NW25
EMF20	191 mm / 7.51 inch	118.4 / 4.66 inch	NW25

MF30 Filters

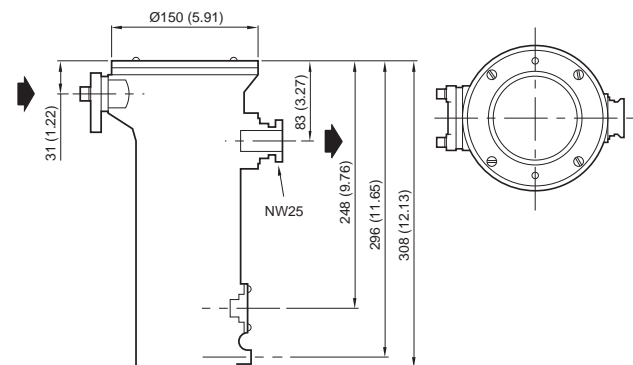

Ordering Information

Product Description	Order No.
Model EMF3 mist filter (0.315 kg)*	A46220000
Model EMF10 mist filter (0.500 kg)†	A46226000
Model EMF20 mist filter (0.700 kg)†	A46229000
Model MF30 mist filter (1.30 kg)‡	A46233000
* Supplied with NW10 clamp, centring-ring and O-ring, NW10 to ¼ inch BSP adaptor.	
† Supplied with NW25 clamp, centring-ring and O-ring, NW25 to ¼ inch BSP adaptor.	
‡ Supplied with NW25 elbow, NW25 clamp, NW25 to ¼ inch BSP adaptor and NW25 Co-Seal.	
Spares	Order No.
Odour element (pack of 5)	
EMF3	A22304081
EMF10	A22304079
EMF20	A22304077
Oil element	
EMF3	A22304197
EMF10	A22304198
EMF20	A22304199
MF30	A22304057
Body seal	
EMF3	A27159538
EMF10	A27159535
EMF20	A27159534

Oil Return Kits

Oil return kits These conserve the pump oil, by returning the oil trapped in the mist filter to the pump. The gas ballast oil return kit, for example, allows extended operation of the pump with gas ballast.

Ordering Information

Product Description	Order No.
Clean application oil return kit (RV, Speedivac 2 to E2M0.7, E2M1.5)	A50419000
Adjustable gas ballast oil return kit (RV)	A50523000
Clean application oil return kit (E1M18 to E2M28)	A50420000

Inlet Liquid Catchpots

These catchpots minimize the entry of condensable vapours into the pump. Benefits of the catchpots include:

- Capture condensable vapours, which would otherwise condense in the pipelines or in the pump
- Prevents froth or spray from the process from carrying over to the pump
- Corrosion-resistant body
- Visual indication of trapped liquid level
- Hand-tightened drain plug, for easy drainage

Ordering Information

Product Description	Order No.
ITO20K inlet catchpot, 1.84 litres capacity, weight 3.2 kg	A44110000
Small volume inlet catchpot 0.1 litre capacity, weight 0.3 kg	A44105000
Both supplied with NW25 clamp, centring-ring and O-ring.	

ITD20K Inlet Desiccant Trap

The ITD desiccant trap is intended for use when pumping limited quantities of water vapour at high pumping speeds to a low vapour pressure using phosphorous pentoxide (P₂O₅) as the desiccant. P₂O₅ (not supplied by Edwards) absorbs more than 20% (by weight) of water whilst still maintaining a low vapour pressure.

The trap body is an aluminium casting which contains a tray assembly made of stainless steel. The condition of the desiccant can be observed through a glass cover fitted to the top of the trap.

Ordering Information

Product Description	Order No.
ITD20K Inlet Desiccant Trap	A44510000

ITC20K Inlet Chemical Traps

The ITC series of chemical traps provides the following benefits:

- Protection against various aggressive vapours, which may attack the pump or pump oil
- Prevent high molecular weight vapours (such as might arise in a resin treatment plant), from reaching the pump. These vapours could cause lacquering or clogging
- The standard sorbent (activated charcoal), has relatively high trapping properties (absorbs around 25% of its own weight), even when large amounts of water vapour are being pumped
- When filled with activated alumina on two-stage pumps, backstreaming of pump oil can be controlled
- See also ITO catchpots for design advantages of the body

Ordering information

Product Description	Order No.
ITC20K inlet chemical trap charcoal charge 0.4 kg, weight 3.5 kg	A44410000
Sorbent charge not supplied. Supplied with NW25 clamp, centring-ring and O-ring.	
Spares	Order No.
0.5 kg activated charcoal	H12205001
3 kg activated charcoal	H12205002
0.45 kg activated alumina	H02600050
0.2 kg activated alumina	H02600056

ITF20K Inlet Dust Filter

The ITF inlet dust filters prevent the entry of dust particles into the pump. The impedance of a clean filter reduces the pumping speed of a 20 m³h⁻¹ pump by about 20% at 1 mbar and 25% at 10 mbar.

Depending on your application, you can normally clean the filter element with a vacuum cleaner or a clean air blast, and then re-use the element.

The benefits of the ITF filters include:

- Thick aluminium casting, to withstand abrasion
- Tangential entry port, to promote centrifugal separation of dust particles
- Filter efficiency better than 96% (tested to BS2831, dust number 2).

Dimensions

ITO20K, ITC20K and ITF20K

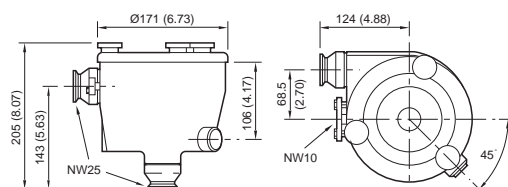

Ordering Information

Product Description	Order No.
ITF20K inlet dust filter (3.4 kg)	A44215000
ITF20K element and gasket kit (0.3 kg)	A44201800

EBV Gas Ballast Control Valves

Fit the EBV 20 valve to allow remote operation of the pump's gas ballast control.

Ordering Information

Product Description	Order No.
EBV20 110 V 1-ph 50/60 Hz	A50006984
EBV20 (0.5 kg) 220 - 240 V 50/60 Hz	A50006930
Suits the E2M0.7 to E2M28 including RV	
For RV and XDS pumps an adaptor is required	A50502000
For the E1M18/E2M28 an adapter is required	A50006003

Acoustic Enclosures

Designed for use in a laboratory or an industrial environment, Edwards new acoustic enclosures are compatible with all EM, RV and nXDS/XDS pumps ranging up to the E2M28 series/XDS46i.

The acoustic enclosure reduces the noise level by up to 9dBA and incorporates internal fans to ensure adequate air cooling is provided to the pump. They are also CSA/UL compliant.

The design of the enclosure allows for it to be easily assembled or disassembled without tooling. A removable front panel also allows for quick access to the oil sight glass and if required a side panel can be removed allowing access to the oil filler cap (EM/RV only). The enclosure is powered via a power cable fitting into an IEC 320 socket.

- Simple slot together assembly means no tools are required
- Designed to attenuate the noise of an E2M28 by 7dBA or an XDS35i/46i by 9dBA
- Integrated cooling fans to maintain optimum pump running temperature
- Castor wheels with brakes for easy manoeuvrability
- Fully compatible with Edwards inlet traps, exhaust mist filters and nXDS/XDS silencer with extension spools (available separately)
- Over temperature buzzer alarm with battery back-up

Dimensions

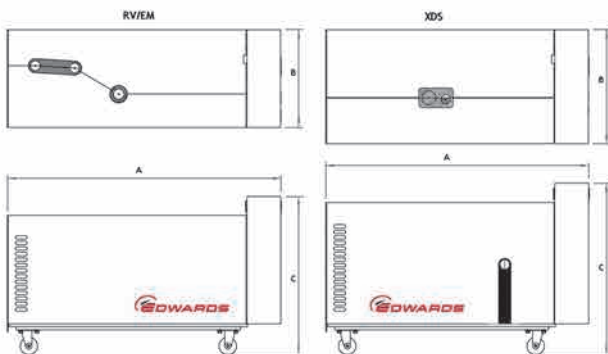

Dimension	RV/EM	nXDS/XDS
A	790 mm	778 mm
B	285 mm	442 mm
C	460 mm	580 mm

Technical Data

Mass (RV-EM/XDS)	23 kg/ 37 kg
Electrical supply for cooling fans	
Voltage	100-120 V/200-240 V
Fuse rating	5 A Type T 20 mm
Connector	IEC320 socket
Approximate noise reduction	
RV	7dBA
E2M28	7dBA
XDS35i/46i	9dBA

Ordering Information

Product Description	Order No.
RV/EM acoustic enclosure 110-120V (NRD317000)	A50635906
RV/EM acoustic enclosure 200-240V (NRD418000)	A50635903
nXDS/XDS acoustic enclosure 110-120V	A50636906
nXDS/XDS acoustic enclosure 200-240V (NRD797000)	A50636903
Accessories & Spares	Order No.
2m Electrical supply cable, UK 3 pin plug	A50505000
2m Electrical supply cable, N. Europe plug	A50506000
2m Electrical supply cable, USA/Japan plug	A50507000
2m Electrical supply cable, no plug	A50508000
NW25 Aluminium nipple 100mm long	C10514409
NW40 Aluminium nipple 130mm long	C10516409

FL20K Foreline Trap

The FL20K foreline trap has been developed for use in clean pumping systems, to prevent the back-migration of rotary pump oil mist into the system. The activated alumina sorbent has the following benefits:

- Exceptional trapping properties for oil mist (99.7%)
- A very long life before it is saturated
- Can be rejuvenated by baking the basket containing the sorbent for 2 hours at 250 °C – 300 °C.

The FL20K is most useful with two-stage rotary pumps, operating below 1 mbar. To maximize sorbent life, install the FL20K near the vacuum system. In common with other types of sorbent, activated alumina absorbs water. This does not affect the oil vapour trapping properties but may tend to prolong the roughing time on successive pump downs. To minimize vapour absorption, we recommend you fit a valved by-pass line.

The trap body is made of aluminium and is fitted with a removable basket containing the sorbent.

Dimensions

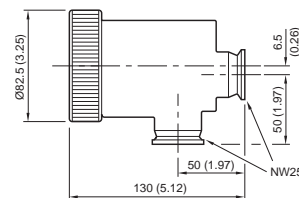

Ordering Information

Product Description	Order No.
FL20K foreline trap weight 1kg (Supplied with 0.2 kg sorbent charge)	A13305000
Spares	Order No.
0.45 kg activated alumina	H02600050
0.2 kg activated alumina	H02600056

Vibration Isolators

You may need to fit vibration isolators to your pump if you mount it into a frame or a system, if the mounting points are not level or if you need to minimize the transmission of vibration and noise in your application. You must fit flexible bellows or other flexible pipes to the pump inlet and outlet.

The height of these neoprene rubber isolators reduces by about 1 mm when the pump is fitted.

Dimensions

E2M0.7, E2M1.5

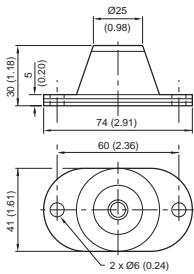

RV Pumps, E1M18/E2M18, E2M28, nXDS and XDS35i

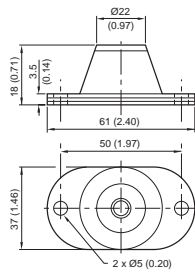

Ordering Information

Product Description	Order No.
Vibration isolators	
E2M0.7, E2M1.5 (0.3 kg)	A24801407
RV, E1M/E2M18 (0.45 kg)	A24801404
E2M28 (0.45 kg)	A24801412
XDS35i (0.45 kg)	A24801408
nXDS (0.45 kg)	A24801441

Oil Box Drain Kits

Two kits are available:

- RV easy oil box drain kit. This kit includes an oil drain extension tube for use when the oil is gravity drained. Fits E2M0.7, E2M1.5, RV, E1M18, E2M18, E2M28.
- ODP20, for use with the E1M18, E2M18 and E2M28 pumps. This accessory provides alternative methods for draining oil where access to the pump drain plug is difficult, or where there is no room for a receptacle under the drain outlet. The pack includes an oil drain extension tube for use when oil is gravity drained, and a pressure drain device with which the oil can be discharged at a high level.

Ordering Information

Product Description	Order No.
RV easy oil box drain kit	A50503000
ODP20 oil box drain kit	A50002000

Exhaust Silencers

For use on XDS pumps that are not connected to a house exhaust system. These silencers also offer exhaust filtration.

Ordering Information

Product Description	Order No.
Exhaust silencer	
nXDS	A50597000
XDS35i	A50597001
Spares	Order No.
silencer spares kit	
nXDS	A50597800
XDS35i	A50597801

OB20 Oil Box Purge Adaptor

This stainless steel adaptor enables a flow of dry inert gas to be introduced into the oil box to provide large scale dilution of process gases which cannot be dealt with sufficiently by the standard gas ballast facility. The adaptor replaces the oil filler plug, on the RV and E1M18/E2M18 pumps only.

Ordering Information

Product Description	Order No.
OB20 oil box purge adaptor	A50034000

Oil Change Reminder Tag

The oil change reminder tag is a useful reminder for users to change the oil when it starts to go brown. Brown oil indicates that the oil is contaminated or degraded, and must be changed to prevent mechanical wear or failure of the pump. Tie the tag onto the pump exhaust so that it hangs over the oil box.

Ordering Information

Product Description	Order No.
Oil change reminder tag (pack of 10)	A20003017

Water Jet Pump 0.23 m³h⁻¹

Fits laboratory tap and ordinary water supply for simplest production of rough vacuum for distillation, filtration, aeration etc. An integral non-return valve prevents system flooding from fluctuating water pressures.

Technical Data

Material of construction	Corrosion resistant plastic equivalent to stainless steel
Recommended water pressure	1.4 bar / 20 lbs inch ⁻¹
Operational water temperature	15°C / 59°C
Pumping speed (air)	0.23 m ³ h ⁻¹ – 3.9 l min ⁻¹
Ultimate vacuum	16 – 19 mbar / 12-14.25 Torr
Time to evacuate volume of 5 litres down to 60 mbar	3 min approx
Water consumption	625 l h ⁻¹ / 2.75 gal (US) min ⁻¹
Connections	
Water	12 mm tubing
Vacuum	riffled to suit 7 mm bore tubing
Drain	¾ inch (9.5 mm) tubing
Weight	34 g
Size	60 W x 110 L / 2.5 inch x 4.3 inch

Ordering Information

Product Description	Order No.
Water jet pump	C41001000
Fluoroelastomer ball/pin assembly for non-return valve	C03901010

D-LAB Diaphragm Vacuum Pump



1

Page
46



The D-LAB membrane pumps with their chemically resistant Teflon® heads, diaphragms and Kalrez® valves offer the chemical or pharmaceutical laboratory user a wide range of choice, either used as stand-alone pumps or as part of a sophisticated system. The one head, 100 mbar ultimate vacuum pumps are suitable for use with drying equipment or for replacing water-jet pumps, whilst the two head, 8 mbar ultimate vacuum pumps are suitable for rotary evaporation, gas transfer and a wide range of medium vacuum applications. 110V pumps are supplied with USA plug; 220-240V pumps are supplied with an IEC connector but mains cable with correct plug must be ordered separately.

Features & Benefits

- Teflon® heads and diaphragms
- One and two head versions
- 3 Sizes
- Compact, space-saving design
- Low noise

Dimensions

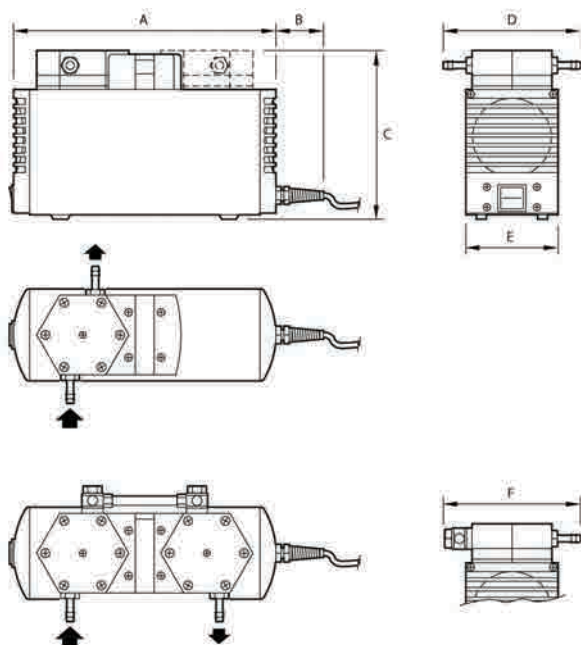

D-Lab	A	B	C	D	E	F
10-100	255	50	182	144	98	-
20-100	268	60	204	157	110	-
34-100	296	60	222	172	122	-
10-8	288	53	184	-	98	140
20-8	312	59	204	-	110	153
34-8	341	62	222	-	122	169

Applications

- Rotary evaporation
- Gel drying
- Vacuum desiccation
- Vacuum filtration
- Vacuum degassing

Technical Data

Pumping speed (air)	
10-100, 10-8	0.6 m ³ h ⁻¹ , 10 lmin ⁻¹
20-100, 20-8	1.2 m ³ h ⁻¹ , 20 lmin ⁻¹
34-100, 34-8	2 m ³ h ⁻¹ , 34 lmin ⁻¹
Ultimate vacuum	
10-100, 20-100, 34-100	100 mbar 50Hz, 75 mbar 60Hz
10-8, 20-8, 34-8	8 mbar 50Hz, 6 mbar 60Hz
Inlet and outlet connection	Riffled nozzle, suitable for 9 mm i.d. hose
Maximum inlet pressure	1 bar
Motor power and current	
10-100, 110V 60Hz	110 W 1.3 A
10-100, 220-240V 50Hz	100 W 0.6 A
20-100, 110V 60Hz	145 W 1.9 A
20-100, 220-240V 50Hz	130 W 0.9 A
34-100, 110V 60Hz	220 W 3.2 A
34-100, 220-240V 50Hz	180 W 1.4 A
10-8, 100V 60Hz	110 W 1.3 A
10-8, 220-240V 50Hz	90 W 0.6 A
20-8, 110V 60Hz	130 W 1.2 A
20-8, 220-240V 50Hz	120 W 0.9 A
34-8, 110V 60Hz	250 W 3.2 A
34-8, 220-240V 50Hz	200 W 1.5 A
Enclosure rating	IP44
Operating temperature	5 - 40 °C
Weight	
10-100	5.8kg / 12.8lbs
20-100	7.1kg / 15.6lbs
34-100	10.3kg / 22.7lbs
10-8	6.9kg / 15.2lbs
20-8	9.3kg / 20.5lbs
34-8	12.6kg / 27.7lbs

Performance Curves

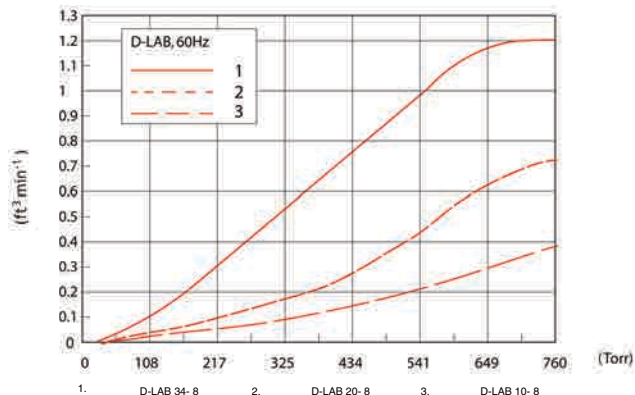
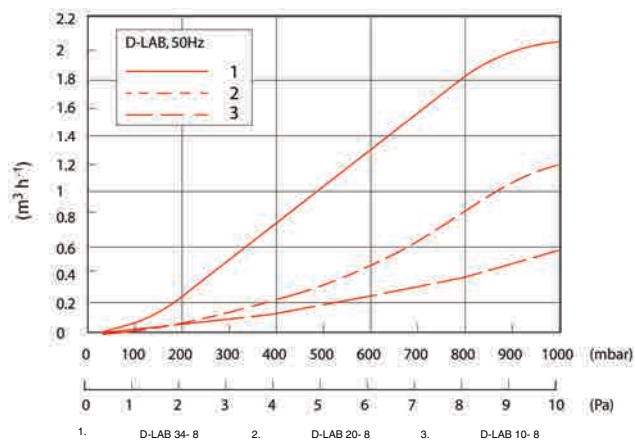
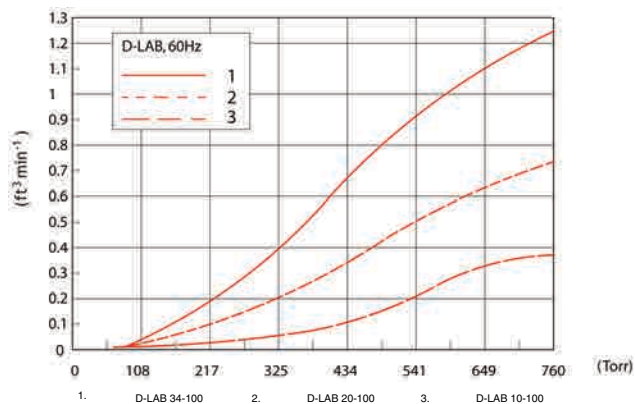
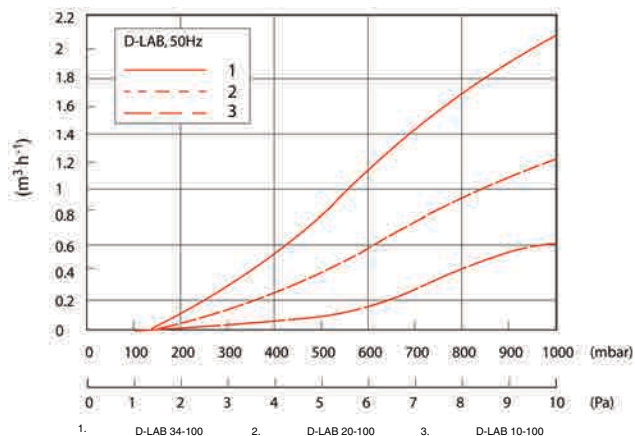

Ordering Information

Product Description	Order No.
D-LAB 10-100, 110V, 60Hz, 1-ph	A48015941
D-LAB 10-100, 220-240, 50Hz, 1-ph	A48015960
D-LAB 10-8, 110 V 1-phase 60 Hz	A48016941
D-LAB 10-8, 220-240~ 50Hz, 1-ph	A48016960
D-LAB 20-100, 110V 60Hz, 1-ph	A48017941
D-LAB 20-100, 220-240~ 50Hz, 1-ph	A48017960
D-Lab 20-8, 110 V 1-phase 60 Hz	A48018941
D-Lab 20-8, 220-240V 50Hz, 1-ph	A48018960
D-LAB 34-100, diaphragm pump, 110~ 60Hz, 1-ph	A48021941
D-LAB 34-100, 220-240~ 50Hz, 1-ph	A48021960
D-LAB 34-8, diaphragm pump, 110V 60Hz, 1-ph	A48022941
D-LAB 34-8, diaphragm pump, 220-240 V 1-phase 50 Hz	A48022960
Accessories & Spares	Order No.
D-Lab Base Plate 10+20-X	A48015134
Baseplate For D-Lab Pumps 34-100,34-8.	A48021134
D-Lab Separator	A48015136
Condenser For D-Lab Pumps	A48015137
2m electrical supply cable for 1-ph pumps, UK, Three-pin plug	A50505000
2m electrical supply cable for 1-ph pumps, North European plug	A50506000
2m electrical supply cable for 1-ph pumps, no plug	A50508000
Gas Ballast For D-Lab Pumps 10-100,10-8	A48015135
D-Lab Gas Ballast 20+34-8	A48017135
D-Lab Controller 230V	A48015138
D-Lab Controller 100/110V	A48015139
Service kit for D-LAB 10-100	A48015815
Service Kit D-Lab 20-100	A48017815
Service Kit D-Lab 34-100	A48021815
Service Kit D-Lab 10-8	A48016815
Service Kit D-Lab 20-8	A48018815
Service Kit D-Lab 34-8	A48022815

XDD1 Diaphragm Vacuum Pump



1

Page 48



The Edwards XDD1 diaphragm pumps are used for backing small compound turbomolecular pumps in clean, high vacuum applications. They comply with EN61010, EN1012, CSA/UL and are designed to be free standing bench top units.

The a.c. voltage motor can be used on worldwide supplies ranging from 100 to 115 V, and 200 to 230 V. The d.c. voltage motor runs on 24 V via a 15 pin DIN connector. By selecting the appropriate mode the pump speed can be controlled by the user to provide variable pumping speed. This version is suited to the customer who is building their own a system. Pumps are not supplied with connection cables. A suitable cable should be ordered with the pump.

Features & Benefits

- Dry pumping, oil free turbomolecular backing pump with no oil disposal issues
- Compact and lightweight with a small footprint
- Worldwide a.c. voltage or 24 V d.c.
- On/off switch
- EN 60320 connector on AC pumps

Dimensions

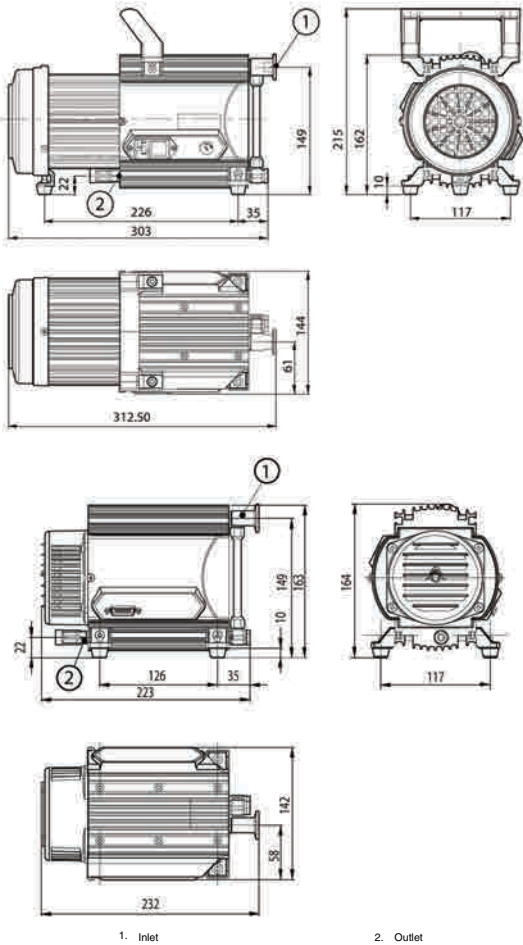

Applications

- RGA
- Mass spectrometers
- Cryostat and Dewar evacuation
- Ion pump evacuation
- Surface science

Performance Curves

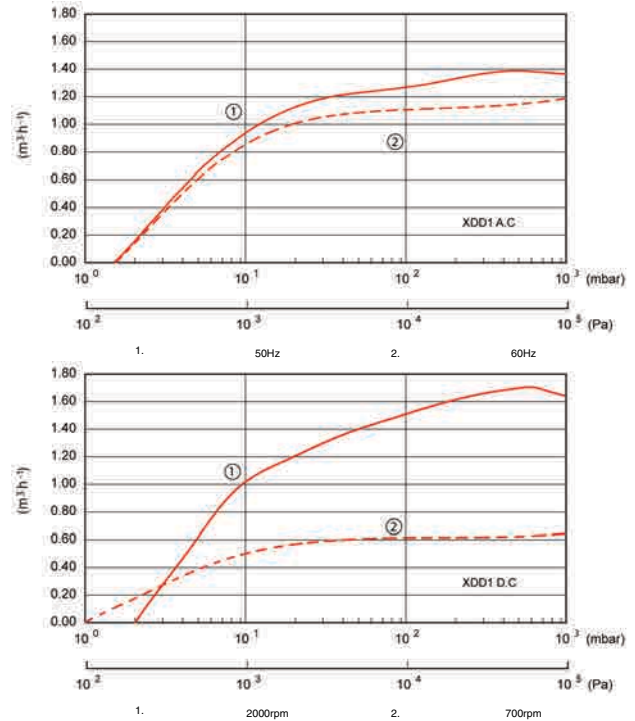

Technical Data

Pumping Speed	
a.c.	
50Hz	1.2 m ³ h ⁻¹
60Hz	1.5 m ³ h ⁻¹
d.c.	
50Hz	0.6 m ³ h ⁻¹ 600 rpm
60Hz	1.6 m ³ h ⁻¹ 2200 rpm
Ultimate vacuum (typical)	<2 mbar
Ambient temperature limit	10 to 40 °C
Inlet connection	NW16
Exhaust connection	The pump is fitted with a silencer which can be removed and an exhaust line connected with a 1/8 inch BSP fitting
Max allowed inlet pressure	1 bara
Power connector	IEC EN60320 C13
Motor power	
a.c.	80 W
d.c.	64 W
Weight	
a.c.	6.5 kg
d.c.	4.1 kg

Ordering Information

Product Description	Order No.
XDD1 Diaphragm Pump 100-115V/200-230V 50/60 Hz	A74602983
XDD1 Diaphragm Pump 24 V d.c.	A74602991
Accessories & Spares	Order No.
2m electrical supply cable for 1-ph pumps, UK plug 3A	A50516000
2m electrical supply cable for 1-ph pumps, no plug	A50508000
2m electrical supply cable for 1-ph pumps, North America/Japan plug	A50507000
2m electrical supply cable for 1-ph pumps, North European plug	A50506000
XDD/DX/EXDC Extension Cable 1m	D39700835
XDD/DX/EXDC Extension Cable 2m	D39700836
XDD/DX/EXDC Extension Cable 5m	D39700837
XDD1 diaphragm service kit	A74601800

This page is intentionally left blank.

1

Page
50

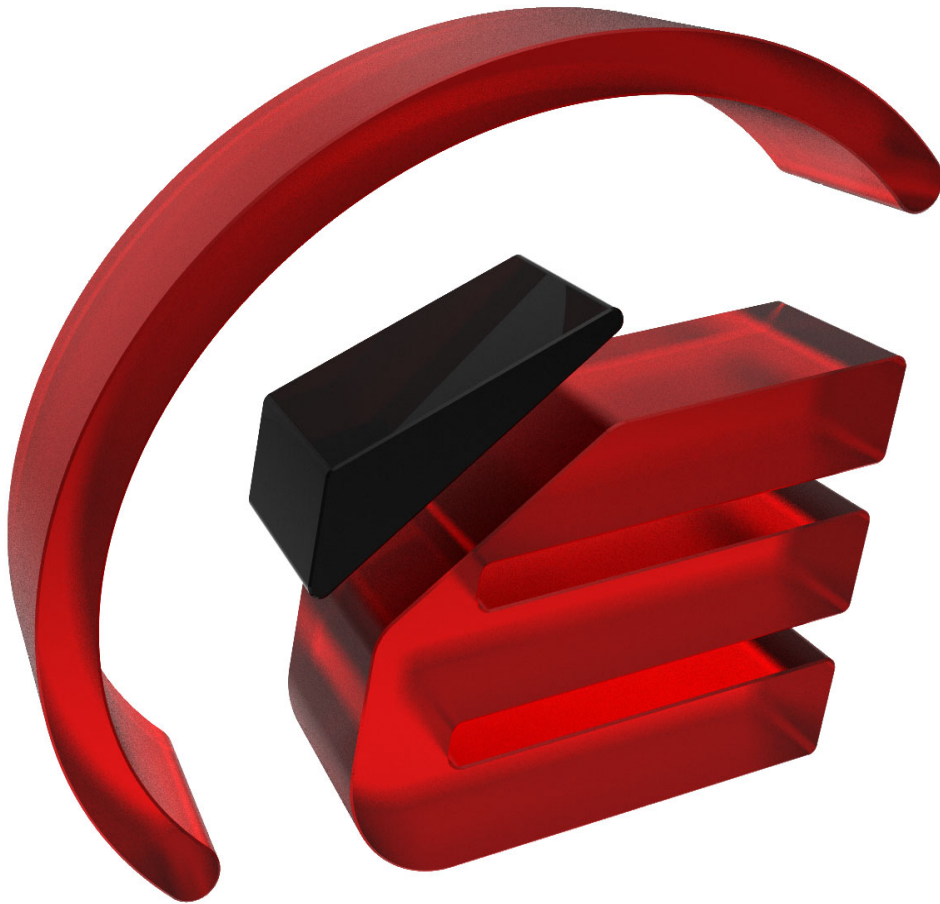



nEXT Turbomolecular Pumps	54
EXT Turbomolecular Pumps	60
TAG Turbo and active gauge controller	64
TIC Turbo Controllers	66
EXT and nEXT Accessories	70
Turbocarts	72
nEXT Turbopumping Stations	74
STP Magnetically Levitated Turbomolecular Pumps	75
STPs and the Environment	77
STP Pump with Integrated Controller	78
Ultra High Vacuum STP Pumps	86
High Throughput STP Pumps	94
Advanced High Throughput STP Pumps	98
High Flow and High Throughput STP Pumps	106
STP Controllers	112

EXT and nEXT Turbomolecular Pumps and Controllers

2

Page
52



Our range of EXT and nEXT compound turbo molecular pumps and TIC Controllers use state-of-the-art technology to provide reliable, high and ultra high vacuum.

Key Performance Factors

A turbomolecular pump (TMP) is a multi-stage axial-flow turbine in which high speed rotating blades provide compression by increasing the probability of gas molecules moving in the pumping direction. The turbomolecular pump is optimised for molecular flow conditions and requires a suitably sized two stage rotary vane pump or an oil free scroll pump to exhaust to atmosphere.

A compound molecular pump (CMP) is based on the concept of combining bladed turbomolecular stages with molecular drag stages on the same rotor. This design allows:

- High critical foreline pressures (typically up to 10 mbar)
- Options to use smaller backing pumps or dry diaphragm backing pumps

Pumping Speed (volume flow rate) is determined by the rotor diameter, inlet flange size and rotational speed. The pumping speed reduces at high inlet pressures to a value determined by the size of the backing pump.

As the inlet pressure rises, the motor power dissipation and pump temperature increase. **Maximum continuous inlet pressure** sets the maximum throughput limit for steady state pumping and depends on the cooling method used. Above this pressure, the rotational speed of the pump reduces as temperature sensors limit the pump power. With a water-cooled pump, the actual **maximum throughput** depends on the size of the backing pump.

Quiescent Electrical Power is the nominal power dissipated by a pump operating normally at full rotational speed and with low gas throughput (inlet pressure below the 10^{-3} mbar range). During the run-up time, or when operating at high gas throughput or above the critical backing pressure, the pump power dissipation will rise and approach the maximum power output for the turbo Controller used. Critical backing pressure for compound turbomolecular pumps is approximately 10 to 20 mbar.

Compression Ratio is determined by the rotational speed, the number of pump stages and the molecular weight of the pumped gas. It is higher for heavier gases which explains why the suppression of hydrocarbon backstreaming is so effective and why the ratio for hydrogen is important for ultra high vacuum applications.

Ultimate Pressure measured according to Pneurop standards, is the lowest pressure achieved in the test system, 48 hours after bakeout. The system is backed only by a two-stage rotary vane pump.

Fluoroelastomer inlet seals are used with ISO-flanged pumps and metal seals are used with CF-flanged pump models.

Bearing and Suspension Technologies

We use two basic technologies: magnetic bearings and mechanical ceramic ball bearings.

Ceramic bearings, which are lubricated for life by either grease or oil, have replaced conventional steel bearings. The silicon nitride ceramic balls are lighter, harder and smoother than steel equivalents, leading to longer life and lower vibration characteristics. Reliability is increased because the ball and race materials are different, which prevents micro pitting.

Magnetic bearings further increase reliability. Our EXT and nEXT turbomolecular pumps use a hybrid bearing arrangement with a permanent magnet upper bearing and an oil lubricated ceramic lower bearing.

Rotor Technologies

We use two basic technologies:

- compound molecular and fluid dynamic (combining turbomolecular, drag and fluid dynamic stages) available on nEXT 'T' variant pumps
- Compound molecular (combining turbomolecular and drag stages) on all EXT and nEXT 'D' variant pumps.

Motor Technology

EXT pumps use brushless d.c. motors and are available in 24 (EXT75DX), 24 to 48 (nEXT) and 80 (EXT556H) volt variants. For the 24 volt pumps the TIC line of controllers are available with the added benefit of integrated instrument controllers. For the 80 volt pumps you can choose from our EXC line of controllers to optimize the performance and cost options for your application.

The Controllers incorporate a regenerative back-up supply which provides power in the event of electrical supply failure to keep the vent-valve closed for several minutes.



Ceramic ball bearings

Corrosive Applications

For maximum life and reliability in the exacting process conditions encountered in semiconductor wafer processing applications, we recommend that you use turbomolecular pumps from our Edwards STP-C and STPH-C series. These Maglev pumps have magnetic bearings and are ideal for these harsh duty applications.

Purge Port

The EXT and nEXT pumps all have purge-ports which can be used to purge the motor and bearing cavity with an inert gas (such as nitrogen). We recommend that you purge the pump when you pump corrosive and abrasive gas mixtures or those with an oxygen content over 20%. You can use our PRX10 purge-restrictor to set the purge gas flow rate. This typically adds up to 25 sccm to the total gas load and the backing pump must be sized accordingly.

Venting

To maintain the cleanliness of your vacuum system, we recommend that you vent a turbomolecular pump at or above half rotational speed, when the rotor is still spinning fast enough to suppress any backstreaming of hydrocarbons from the backing line.

The vent port on the EXT and nEXT pump is part way up the rotor stack to ensure maximum cleanliness even with fluoroelastomer sealed vent-valves. Each pump is supplied with a manual vent-valve. If you use this manual valve care must be taken not to open it too quickly, especially if the system volume is small (typically less than the approximate volume of the turbomolecular pump), because if the rate of pressure rise is too high, the pump bearing life may be reduced.

In a small volume system, the rate of pressure rise will be greater than in a large volume for a given vent flow rate, and it may be necessary to restrict the vent gas flow. We offer the VRX range of vent restrictors which you can fit to your EXT or nEXT pump.

Since the rate of pressure rise cannot be accurately controlled by the manual vent-valve, we recommend that, unless you fit a suitable VRX restrictor to the vent port, you must wait until the turbomolecular pump has slowed down to 50% speed, as indicated by the controller, before you open the manual vent-valve.

The maximum rate of pressure rise varies by pump model, and the Instruction Manual supplied with the pump gives further guidance on this, and the size of vent restrictor needed to meet the fastest pressure rise allowed.

Control of the rate of venting is particularly important with pumps using fully magnetic bearings, otherwise the safety bearings may be damaged.

The manual vent-valve can be replaced with a TAV solenoid valve driven by the Controller to allow venting after a 2 second delay on shut-off, or delaying vent until the rotational speed has dropped to 50%. The Controller can also control the TAV vent-valve in the event of power or pump failure.

You can choose from two solenoid vent-valve options; the TAV5 which covers most auto-venting applications, and the TAV6 which has a higher conductance than the TAV5 and is designed either for use on larger chambers (typically with a volume greater than 10 litres), or when you want to use a two-stage venting procedure for the fastest possible vent times.

For two-stage venting you need two TAV valves. By using the appropriately restricted flow for the first stage vent-valve you can start venting when the pump is still at full rotational speed. Once the pump has slowed to half rotational speed you can then introduce higher flow rates from the second stage vent-valve.

EXT75DX and nEXT also have the facility for pulsed venting to allow rapid yet controlled venting of a system.

Inlet-Screen

An inlet-screen is fitted as standard to all EXT pumps and supplied with nEXT pumps. The inlet-screen prevents debris from falling into the pump-inlet. In addition, the inlet-screen prevents you from coming into contact with the blades of the pump when it is disconnected from your vacuum system.

Cooling

For most applications, we recommend that you use forced-air cooling with the appropriate ACX air-cooler connected to your EXT or nEXT pump. NB: high gas load, high backing pressure and rapid cycling require more cooling.

However, if the ambient temperature is above 35 °C you must water-cool the pump.

Water cooling reduces the running temperature of the pump motor and bearings and is particularly recommended when you operate the pump with a continuous high throughput (that is, inlet pressure above 1×10^{-3} mbar) or when you bake the pump to above 70 °C (measured at the inlet flange).

Water cooling accessories need to be purchased separately.

Scope of Supply

For end users desiring front panel controls and indications we suggest the following:

- TIC controller with EXT75DX and nEXT
- EXC300 controller with EXT556H and EXT to EXC cable

Each EXT or nEXT pump is supplied with an inlet screen, elastomer or copper gasket inlet seal (as appropriate) and manual vent valve. Where required a water cooling accessory is available.

Turbo controllers require the appropriate mains cable to be selected.

nEXT240D Turbomolecular Pump



The nEXT240D is a hybrid bearing compound turbopump available with either an ISO100 or a CF100 inlet flange and has a N_2 pumping speed of 240ls^{-1} . nEXT pumps combine our proven bearing technology (oil lubricated ceramic lower bearing with dry permanent magnetic upper bearing), an improved rotor design with a new molecular drag stage to deliver improved pumping speed and compression ratios, and true user serviceability. They feature 24V to 48Vd.c. sensor less motors with a built in drive that is fully compatible with our range of TAG and TIC controllers. They are available pre-set for either 80W or 160W maximum power, the former enabling use with our 100W TIC controllers are also recommended for pumping Argon, but with a longer ramp time to full operating speed.

Features & Benefits

- State-of-the-art rotor design enhances performance to deliver exceptional pumping speeds and compression ratios
- Fully end user serviceable in minimum time without complex tooling or major disassembly...you can do it!
- Compact design with high performance for efficient systemisation
- Compatible with Edwards TIC turbo and instrument controllers meaning you can add up to 3 vacuum gauges without the need of an additional gauge controller
- RoHS compliant and CSA/UL approved

Performance Curves

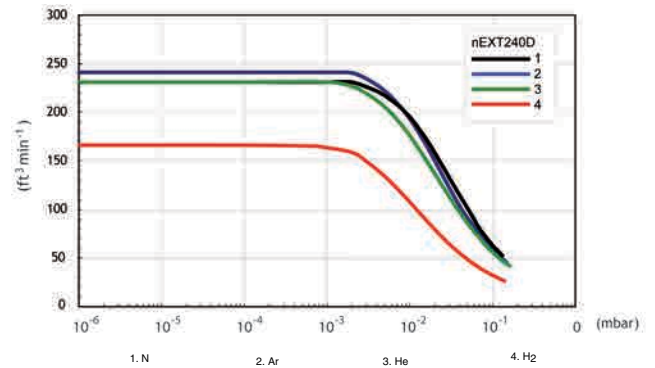

Dimensions

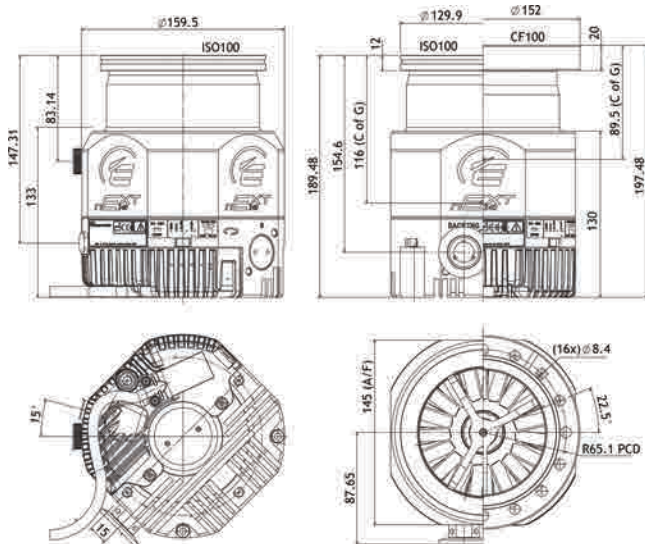

Ordering Information

Product Description	Order No.
nEXT240D Turbomolecular Pump ISO100 Inlet Flange	B81200100
nEXT240D Turbomolecular Pump ISO100 Inlet Flange, 80W	B81200101
nEXT240D Turbomolecular Pump CF100 Inlet Flange	B81200200
nEXT240D Turbomolecular Pump CF100 Inlet Flange, 80W	B81200201
Accessories & Spares	Order No.
DX/nEXT Pump Profibus Communications Module	D39755000

Technical Data

Inlet flange	DN100ISO-K, DN100CF
Outlet flange	DN25NW
Pumping speed	
N ₂	240 ls ⁻¹
He	230 ls ⁻¹
H ₂	165 ls ⁻¹
Compression ratio	
N ₂	>1 × 10 ¹¹
He	3 × 10 ⁵
H ₂	1 × 10 ⁴
Ultimate pressure with RV backing pump ISO/CF	<6 × 10 ⁻⁸ / <5 × 10 ⁻¹⁰ mbar
Recommended backing pump*	RV12/nXDS10i
Vent port	1/8 inch BSP female
Purge port	1/8 inch BSP female
Max continuous inlet flow (Nitrogen) [†]	
Water cooling (water at 15°C, ambient temp at 40°C)	45 sccm
Forced air cooled, 35 °C ambient	30 sccm
Pump rotational speed	
Nominal rotational speed	60000 rpm
Standby rotational speed	Variable from 33000 to 60000 rpm (42000 rpm default)
Programmable power limit settings	Variable from 50-200W (160W default)
Start time to 90% speed	115s‡
Analogue outputs	Pump rotational speed; Power consumption; Pump temp; Controller temp
Cooling method [#]	Forced air / water
Ambient air temp for forced air cooling	5 - 35°C
Min cooling water flow rate (water 15°C)	15 l h ⁻¹
Water temp range	10 - 20°C
Max inlet flange temp	75°C
Operating attitude	Vertical and upright, through to Horizontal +/- 2°
Noise level at 1 metre	<45 dB(A)
Max magnetic field pump can tolerate	5 mT
Recommended controller	TIC200 turbo and instrument controller
Quiescent electrical power	Typically 20W

* A smaller backing pump may be used depending on application. A suitable diaphragm pump with ultimate <5 mbar may also be used e.g. XDD1.

† Above this inlet pressure, rotational speed drops to below nominal.

‡ Power limit set to 160 W.

Air and water cooling accessories must be ordered separately

nEXT300D Turbomolecular Pump



The nEXT300D is a hybrid bearing compound turbo pump available with either an ISO100 or a CF100 inlet flange and has a N_2 pumping speed of 300ls^{-1} . nEXT pumps combine our proven bearing technology (oil lubricated ceramic lower bearing with dry permanent magnetic upper bearing), an improved rotor design with a new molecular drag stage to deliver improved pumping speed and compression ratios, and true user serviceability. They feature 24V to 48Vd.c. sensor less motors with a built in drive that is fully compatible our range of TAG and TIC controllers. They are available pre-set for 80W or 160W maximum power, the former enabling use with our 100W TIC controllers are also recommended for pumping Argon, but with a longer ramp time to full operating speed.

Features & Benefits

- State-of-the-art rotor design enhances performance to deliver exceptional pumping speeds and compression ratios
- Fully end user serviceable in minimum time without complex tooling or major disassembly... You can do it!
- Compact design with high performance for efficient systemisation
- Compatible with Edwards TIC turbo and instrument controllers meaning you can add up to 3 vacuum gauges without the need of an additional gauge controller
- RoHS compliant and CSA/UL approved

Performance Curves

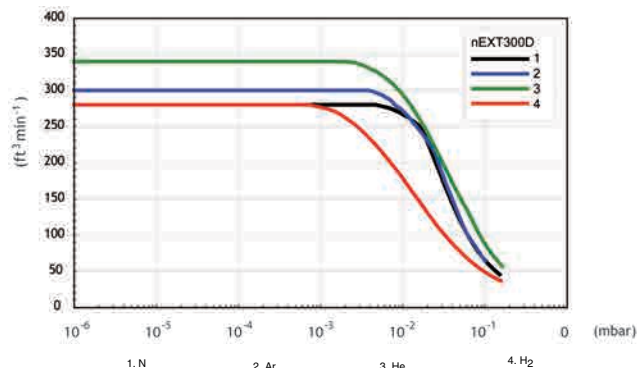

Dimensions

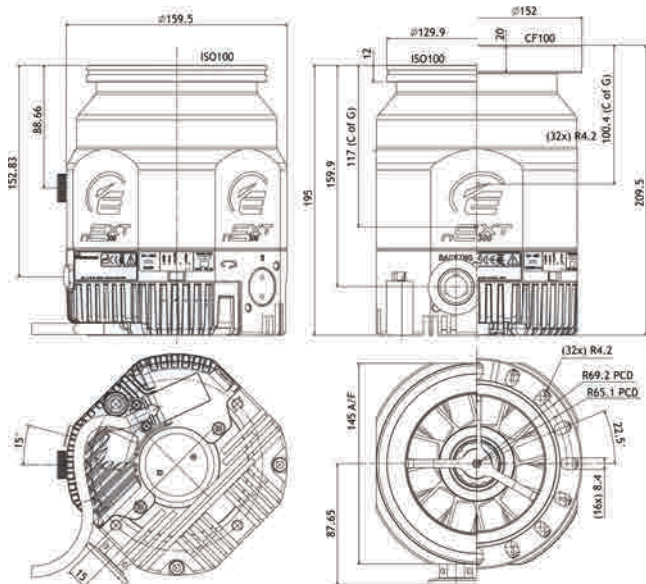

Ordering Information

Product Description	Order No.
nEXT300D Turbomolecular Pump ISO100 Inlet Flange	B82200100
nEXT300D Turbomolecular Pump ISO100 Inlet Flange, 80W	B82200101
nEXT300D Turbomolecular Pump CF100 Inlet Flange	B82200200
nEXT300D Turbomolecular Pump CF100 Inlet Flange, 80W	B82200201
Accessories & Spares	Order No.
DX/nEXT Pump Profibus Communications Module	D39755000

Technical Data

Inlet flange	DN100ISO-K, DN100CF
Outlet flange	DN25NW
Pumping speed	
N ₂	300 ls ⁻¹
He	340 ls ⁻¹
H ₂	280 ls ⁻¹
Compression ratio	
N ₂	>1 × 10 ¹¹
He	1 × 10 ⁶
H ₂	5 × 10 ⁴
Ultimate pressure with RV backing pump ISO/CF	<6 × 10 ⁻⁸ / <5 × 10 ⁻¹⁰ mbar
Recommended backing pump*	RV12/nXDS10i
Vent port	1/8 inch BSP female
Purge port	1/8 inch BSP female
Max continuous inlet flow (Nitrogen) [†]	
Water cooling (water at 15°C, ambient temp at 40°C)	95 sccm
Forced air cooled, 35 °C ambient	115 sccm
Pump rotational speed	
Nominal rotational speed	60000 rpm
Standby rotational speed	Variable from 33000 to 60000 rpm (42000 rpm default)
Programmable power limit settings	Variable from 50-200W (160W default)
Start time to 90% speed	145s‡
Analogue outputs	Pump rotational speed; Power consumption; Pump temp; Controller temp
Cooling method [#]	Forced air / water
Ambient air temp for forced air cooling	5 - 35°C
Min cooling water flow rate (water 15°C)	15 l h ⁻¹
Water temp range	10 - 20°C
Max inlet flange temp	80°C
Operating attitude	Vertical and upright, through to Horizontal +/- 2°
Noise level at 1 metre	<45 dB(A)
Max magnetic field pump can tolerate	5 mT
Recommended controller	TIC200 turbo and instrument controller
Quiescent electrical power	Typically 20W

* A smaller backing pump may be used depending on application. A suitable diaphragm pump with ultimate <5 mbar may also be used e.g. XDD1.

† Above this inlet pressure, rotational speed drops to below nominal.

‡ Power limit set to 160 W.

Air and water cooling accessories must be ordered separately

nEXT400D Turbomolecular Pump



The nEXT400D is a hybrid bearing compound turbo pump available with either an ISO160 or a CF160 inlet flange and has a N_2 pumping speed of $400l\ s^{-1}$. nEXT pumps combine our proven bearing technology (oil lubricated ceramic lower bearing with dry permanent magnetic upper bearing), an improved rotor design with a new molecular drag stage to deliver improved pumping speed and compression ratios, and true user serviceability. They feature 24V to 48Vd.c. sensor less motors with a built in drive that is fully compatible our range of TAG and TIC controllers. They are available pre-set for 80W or 160W maximum power, the former enabling use with our 100W TIC controllers are also recommended for pumping Argon, but with a longer ramp time to full operating speed.

Features & Benefits

- State-of-the-art rotor design enhances performance to deliver exceptional pumping speeds and compression ratios
- Fully end user serviceable in minimum time without complex tooling or major disassembly... you can do it!
- Compact design with high performance for efficient systemisation
- Compatible with Edwards TIC turbo and instrument controllers meaning you can add up to 3 vacuum gauges without the need of an additional gauge controller
- RoHS compliant and CSA/UL approved

Performance Curves

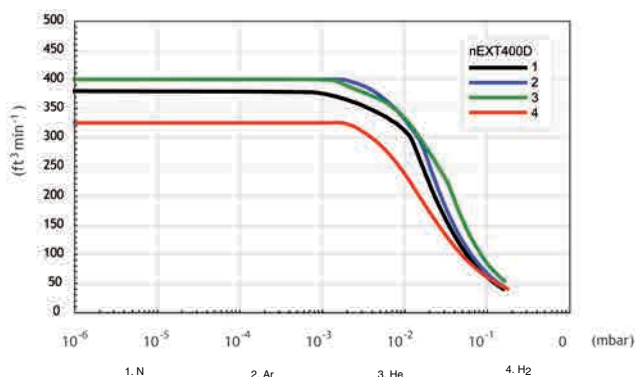

Dimensions

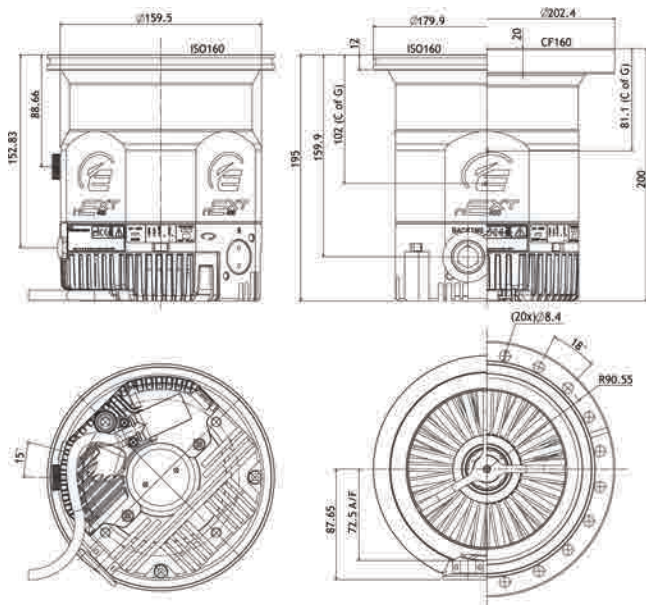

Ordering Information

Product Description	Order No.
nEXT400D Turbomolecular Pump ISO160 Inlet Flange	B83200300
nEXT400D Turbomolecular Pump ISO160 Inlet Flange, 80W	B83200301
nEXT400D Turbomolecular Pump CF160 Inlet Flange	B83200400
nEXT400D Turbomolecular Pump CF160 Inlet Flange, 80W	B83200401
Accessories & Spares	Order No.
DX/nEXT Pump Profibus Communications Module	D39755000

Technical Data

Inlet flange	DN160ISO-K, DN160CF
Outlet flange	DN25NW
Pumping speed	
N ₂	400 ls ⁻¹
He	390 ls ⁻¹
H ₂	325 ls ⁻¹
Compression ratio	
N ₂	>1 × 10 ¹¹
He	1 × 10 ⁸
H ₂	5 × 10 ⁵
Ultimate pressure with RV backing pump ISO/CF	<1 × 10 ⁻⁸ / <1 × 10 ⁻¹⁰ mbar
Recommended backing pump*	RV12/nXDS10i
Vent port	1/8 inch BSP female
Purge port	1/8 inch BSP female
Max continuous inlet flow (Nitrogen) [†]	
Water cooling (water at 15°C, ambient temp at 40°C)	105 sccm
Forced air cooled, 35 °C ambient	90 sccm
Pump rotational speed	
Nominal rotational speed	60000 rpm
Standby rotational speed	Variable from 33000 to 60000 rpm (42000 rpm default)
Programmable power limit settings	Variable from 50-200W (160W default)
Start time to 90% speed	180s‡
Analogue outputs	Pump rotational speed; Power consumption; Pump temp; Controller temp
Cooling method [#]	Forced air / water
Ambient air temp for forced air cooling	5 - 35°C
Min cooling water flow rate (water 15°C)	15 l h ⁻¹
Water temp range	10 - 20°C
Max inlet flange temp	70°C
Operating attitude	Vertical and upright, through to Horizontal +/- 2°
Noise level at 1 metre	<45 dB(A)
Max magnetic field pump can tolerate	5 mT
Recommended controller	TIC200 turbo and instrument controller
Quiescent electrical power	Typically 20 W

* A smaller backing pump may be used depending on application. A suitable diaphragm pump with ultimate <5 mbar may also be used e.g. XDD1.

† Above this inlet pressure, rotational speed drops to below nominal.

‡ Power limit set to 160 W.

Air and water cooling accessories must be ordered separately

EXT75DX Compound Turbomolecular Vacuum Pump



The EXT75DX is a hybrid bearing compound turbo pump that combines the proven technology of a ceramic mechanical lower bearing, a dry permanent magnetic upper bearing and Holweck drag stage with the added convenience of an on-board 24V controller allowing parallel and serial communication compatible with our TAG and TIC controllers. It is available with either aDN40NW, ISO63, DN63CF or an ISO100 inlet flange with an N₂ pumping speed of up to 66ls⁻¹. A basic pump system would require an EXT75DX pump, a TAG or TIC controller, either an air or water cooling accessory and a suitable backing pump.

Dimensions

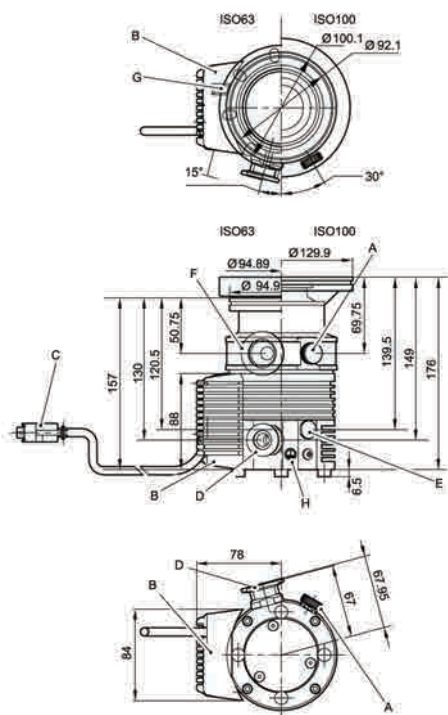

- | | | | |
|---|--------------------------------|---|--------------------------------|
| A | Manual vent valve in vent port | E | Purge port (blanked off) |
| B | Podule | F | Interstage port (EXT75DX only) |
| C | Logic interface connector | G | Podule connector socket |
| D | Backing port | H | Earth connection |

Performance Curves

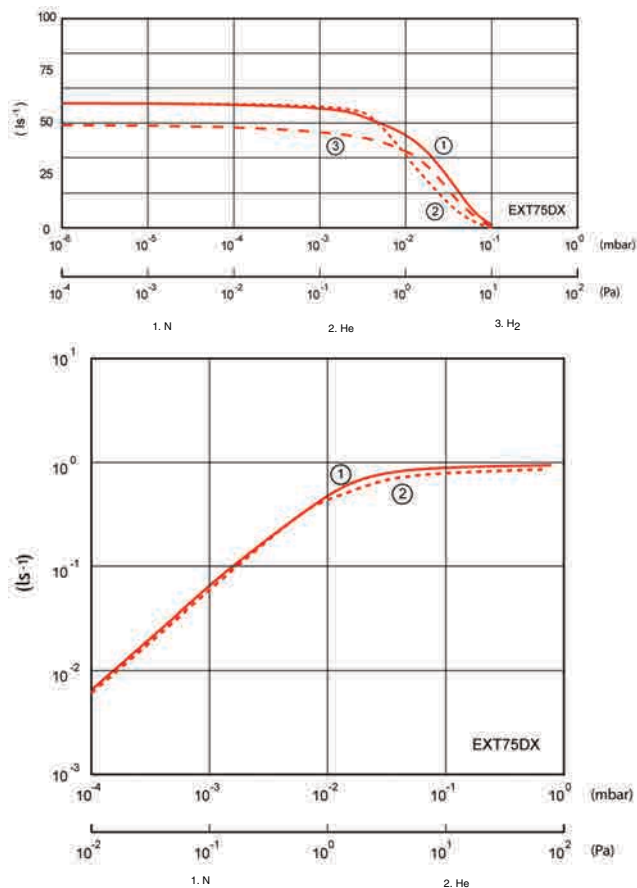

Technical Data

Inlet flange	DN63ISO-K, DN63CF, DN40NW or DN100ISO-K
Outlet flange	DN16NW
Vent/purge port	1/8 inch BSP
Pumping Speed ISO63/63CF (DN40NW)(ISO100)	
N ₂	61 ls ⁻¹ (42 ls ⁻¹) (66 ls ⁻¹)
He	57 ls ⁻¹ (49 ls ⁻¹) (59 ls ⁻¹)
H ₂	53 ls ⁻¹ (48 ls ⁻¹) (54 ls ⁻¹)
Compression ratio	
N ₂	>1 × 10 ¹¹
He	1 × 10 ⁶
H ₂	5 × 10 ⁴
Recommended backing pump*	RV5/nXDS6i
Max continuous inlet pressure (light gas pumping) [†]	
water cooling (water at 15 °C, ambient temp at 40 °C)	2 × 10 ⁻² mbar
forced air cooled, 35 °C ambient	1 × 10 ⁻² mbar
Pump rotational speed	
Nominal rotational speed	90000 rpm
Standby rotational speed	Variable from 49500 to 90000 rpm (63000 rpm default)
Programmable power limit settings	Variable from 50-120W (80W default)
Analogue outputs	Rotational speed; Power consumption; Pump temp; Controller temp
Start time to 90% speed	110 s ‡
Ultimate Pressure (ISO/CF)	
RV backing pump	<5 × 10 ⁻⁹ / 5 × 10 ⁻¹⁰
Diaphragm backing pump	<5 × 10 ⁻⁸ / 5 × 10 ⁻⁹
Cooling method [#]	Forced air / water
Ambient air temperature for forced air cooling	5 - 35 °C
Min cooling water flow rate (water 15 °C)	15 l h ⁻¹
Water temp range	10 - 20 °C
Max inlet flange temp	100 °C
Operating attitude	Vertical and upright, through to Horizontal
Noise level at 1 metre	<50 dB(A)
Max magnetic field pump can tolerate	5 mT
Recommended controller	TIC100
Quiescent electrical power	10 W

* A smaller backing pump may be used depending on application. A suitable diaphragm pump with ultimate <5 mbar may also be used e.g. XDD1.

† Above this inlet pressure, rotational speed drops to below nominal.

‡ Power limit set to 80 W.

Air and water cooling accessories must be ordered separately

Ordering Information

Product Description	Order No.
EXT75DX DN63ISO-K	B72241000
EXT75DX DN63CF	B72242000
EXT75DX DN40NW	B72243000
EXT75DX DN100ISOK	B72245000
EXT75DX DN100ISO-K (DN25NW Backing)	B72246000
EXT75iDX Turbo Pump DN40NW	B72235000
EXT75iDX Turbo Pump DN63ISO-K	B72237000
EXT75iDX Turbo Pump DN63ISO-K (NW25 Interstage)	B72238000
Accessories & Spares	Order No.
DX/nEXT Pump Profibus Communications Module	D39755000

EXT556H Compound Turbomolecular Vacuum Pump



The EXT556H incorporates our hybrid bearing and enhanced molecular drag pumping technologies with turbopump stages on a single rotor. It is an 80V pump and therefore must be used with an EXC300 controller. The EXC300 is a fully featured controller with a user panel, backing pump relay and bake-out band control. It is rack mountable and can power an air cooler and control a vent valve as well as the turbopump. A basic pump system would require an EXT556H pump, an EXC300 controller, a pump to controller cable, either an air or water cooler accessory, and a suitable backing pump.

Dimensions

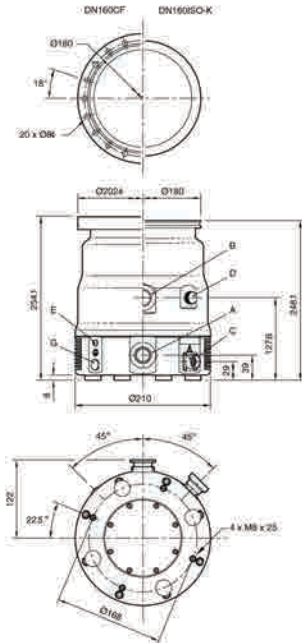

- A Inlet ISO100
- B Inlet ISO160
- C Vent port
- D Earth stud
- E Purge port
- F Backing port
- G Electrical connector
- H Base mount holes (8)/Rubber feet (4)

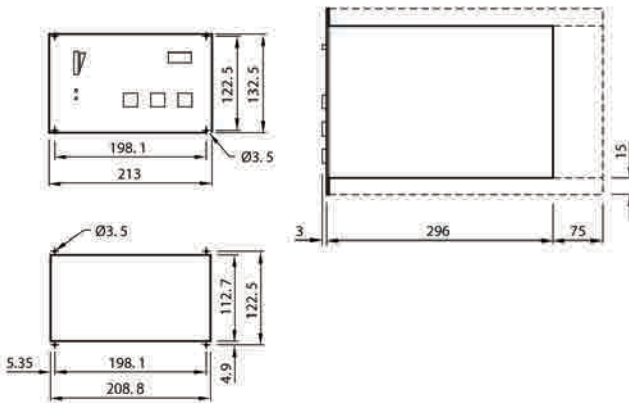

Performance Curves

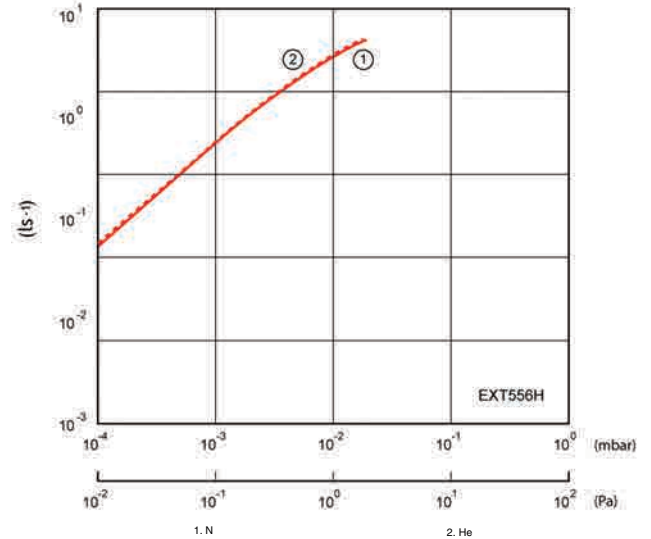
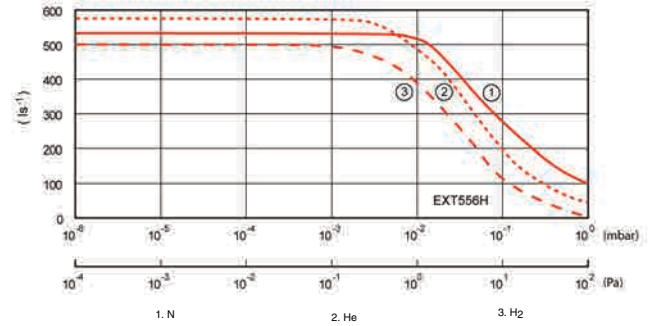

Technical Data

Main Inlet flange	DN160ISO-K/DN160CF
Outlet Flange	DN25NW
Vent/purge port	$\frac{1}{8}$ inch BSP
Inlet pumping speed* (compression ratio)	
N ₂	540 ls ⁻¹ (>10 ¹⁰)
He	580 ls ⁻¹ (10 ⁸)
H ₂	500 ls ⁻¹ (10 ⁶)
Ar	510 ls ⁻¹ (>10 ¹⁰)
Ultimate Pressure (CF variant)	<10 ⁻¹⁰ mbar
Recommended backing pump	RV12/nXDS10i
Max continuous inlet pressure (N ₂ , He, H ₂)**	
forced air cooled, 30 °C ambient	1 x 10 ⁻³ mbar
forced air cooled, 35 °C ambient	5 x 10 ⁻⁴ mbar
water cooling at 15 °C	2 x 10 ⁻³ mbar
Nominal rotational speed	50000 rpm
Start time to 90% speed	
EXC300	6.5 min
Cooling method	Forced air/water
Ambient air temp for forced air cooling	0 °C - 35 °C
Recommended cooling water flow rate (water at 15°C)	15 lh ⁻¹
Water temp range	10 - 20 °C
Max inlet flange temp	80 °C
Operating attitude	Vertical and upright, through to horizontal
Noise level at 1 metre	<60 dB(A)
Max axial magnetic field	<7 mT
Max radial magnetic field	<3 mT
Recommended controller	EXC300
Quiescent power consumption	35 W
Electrical supply voltage	
Electrical supply frequency (EXC250/300)	47 – 63 Hz
Max power output for pump	
EXC300	290W
Weight	
EXT556H ISO/CF	13.4/21.2 kg
EXT556HF ISO/CF	19.3/20.5 kg
EXC300	4.6 kg

* Measured without inlet screen. Inlet screens are supplied fitted and may reduce speed by up to 20%

** With backing pressure <0.3 mbar. Above this inlet pressure rotational speed drops

Ordering Information

Product Description	Order No.
EXT556H DN160ISO-K	B77751000
EXT556H DN160CF	B77752000
EXT556H DN160ISO-K (Martensitic envelope)	B77757000
EXT556H DN160CF (Martensitic envelope)	B77758000
EXT556H DN160ISO-K (Fine inlet screen)	B77761000
Accessories & Spares	Order No.
EXT Pump To Controller Cable 1M	D39618010
EXT Pump To Controller Cable 3M	D39618030
EXT Pump To Controller Cable 5M	D39618050

TAG Controller

2

Page
64



The TAG (Turbo & Active Gauge) controller is a small, compact, low cost pumping system Controller, which is suitable for a wide range of vacuum applications. It is a 24V controller that is compatible with all Edwards DX and nEXT turbopumps. It contains no power source and thus you either need to supply your own power or buy the optional power supply. In addition to a turbopump it can control a backing pump, a vent valve, an air cooler and an Edwards active gauge.

The TAG Controller is controlled by an easy to use interface. A large clear LED display shows the pump speed or vacuum pressure. The compact size of the controller is ideal for use on bench-tops or suitable mobile platforms.

Features & Benefits

- Compatible with all Edwards 24V turbopumps enabling pump control and speed display
- Start/stop control of a backing pump for full system control (external relay may be required)
- Turbomolecular pump start options: start with backing pump, start after time delay or start at pressure set point
- Vent valve control options: controlled vent from full speed, vent from half speed or no vent
- Pressure display from a compatible active gauge in mbar, Torr or Pa

Dimensions

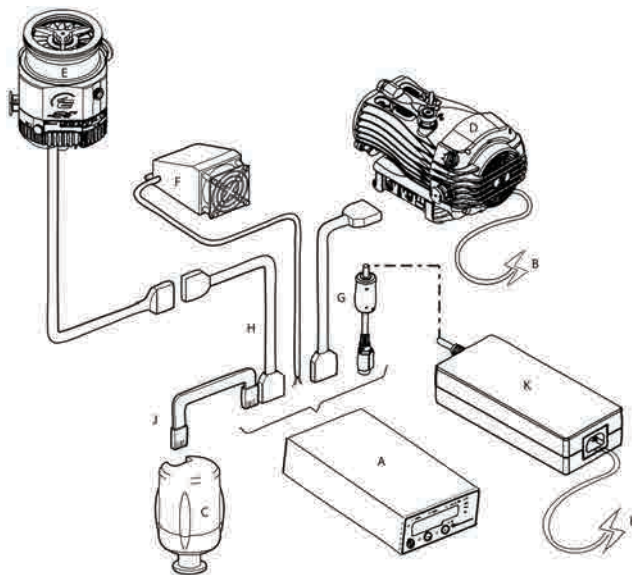

A	Contrôleur TIC (Turbo and Instrument Controller), 200 W
B	Câble secteur / cordon de raccordement
C	WRG-S-NW25
D	Pompe à membrane 24 V c.c. XDD1
E	EXT75DX ISO63
F	Refroidisseur par air ACX75
G	Cordon rallonge XDD/DX/EXDC
H	Cordon rallonge XDD/DX/EXDC (en option)
J	Câble pour jauge active
K	Alimentation électrique

Technical Data

Max input Power	240W
Mains input	
Electrical supply	24V d.c.
Power consumption (max)	5W
Auxiliary terminals	
Air cooling fan	24V d.c. 3.6W max
Turbo pump	24V d.c. 160W max
Dimensions	96 x 48 x 165mm
Mass	0.3kg
Operating temp	0°C to 40°C
Storage temp	-30°C to 70°C
Max ambient operating humidity	90% RH non-condensing at 40°C
Max operating altitude	2000 m
Enclosure rating	IP20. IP40 when panel mounted.

Ordering Information

Product Description	Order No.
TAG Turbo and active gauge controller	D39592000
Accessories & Spares	Order No.
Linecord 2M North Euro Plug	D40013030
Linecord 2M UK Plug	D40013025
Linecord 2m With US Plug	D40013120
XDD/DX/EXDC Extension Cable 1m	D39700835
XDD/DX/EXDC Extension Cable 2m	D39700836
XDD/DX/EXDC Extension Cable 5m	D39700837
200 W power supply	D39592800



A compact turbo controller with a large clear graphical display, an intuitive user interface and serial communications providing full remote control and data logging functions via a new Windows™ based PC program. The controller automatically recognizes and supports one 24 V turbomolecular pump from the EXT/nEXT range. Cooling and vent valve support is provided directly from the controller. Mains backing pumps (up to nXDS20i/RV12) may be controlled via an optional relay box. 2 different power variants are available, 100W or 200W which determines the ramp speed of the turbo pump. In addition 200W models have the ability to power a 24Vdc backing pump such as our XDD1 or nXDS through a 15-way D. Turbo and instrument models add the ability to control up to 3 of our range of Active gauges (excluding IGC & Barocels).

Features & Benefits

- TIC automatically recognizes and controls one 24 V turbomolecular pump from either the nEXT, DX or EXDC ranges. nEXT and DX turbos have full serial communication with TIC and may be both configured and report status via TIC.
- Both mains and 24 V backing pumps may be controlled by TIC. For larger vacuum systems the TIC may control mains backing pumps, up to and including nXDS10 and RV12, via the optional relay box.
- The optional external relay box enables mains backing pumps to be controlled and also provides interfaces for a turbo heater band, a backing line isolation valve and a logic bypass. See relay box section.
- In most instances, TIC systems may be simply and quickly configured using the range of standard cables on offer, there is therefore no need for the customer to prepare loom assemblies or relay boxes and special interfaces.
- TIC is packaged in a compact case and may be panel or rack (¼ 19inch rack 3U) or bench mounted. With the addition of the bezel it becomes an attractive bench-top instrument. The large 128 x 64 pixel backlit graphics LCD and mobile phone style menu system simplifies programming and with a choice of summary screens excellent visibility of displayed parameters is assured.

Dimensions

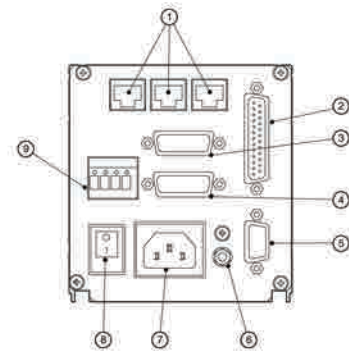

1. Gauge inputs (FCC68 (RJ45) (turbo & instrument only)
2. Logic interface (25-way 'D' socket)
3. Backing pump 24V (15-way 'D' socket) (TIC200 only)
4. Turbo Pump 24V (15-way 'D' socket)
5. RS232/485 (9-way 'D' socket)
6. Earth stud (M4)
7. Mains input (CEE/IEC 320 plug)
8. Mains on/off switch
9. Auxiliary vent valve and fan terminals (24V supply) 4-way screw term.

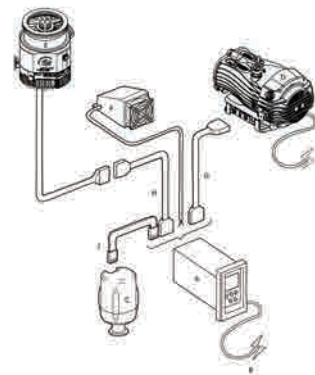

- A. TIC turbo and instrument controller, 200W
- B. Mains cable/line cord
- C. WRG-S-NW25
- D. XDD1 24Vdc diaphragm pump
- E. EXT75DX ISO63
- F. ACX75 air-cooler
- G. XDD/DX/EXDC extension cable
- H. XDD/DX/EXDC extension cable (optional)
- J. Active gauge cable

Technical Data

Pump / TIC power	100W / 200W
EXT75DX	Fast / Fast
nEXT 80W	Slow / Slow
nEXT 160W	Slow / Fast
Mains input	
Electrical supply	90 to 264 V a.c. 47 to 63 Hz
Power consumption (max)	215 VA
Peak inrush current	10.3 A @ 110 V a.c. / 23.0 A @ 230 V a.c.
Earth stud	M4
Auxiliary terminals	
Air cooling fan	24 V d.c. 3 W max, ACX70, ACX75 & ACX250H
Vent valve	24 V d.c. 2 W max, TAV5 & TAV6
Dimensions	
Electronics housing	110 mm high x 105 mm wide x 245 mm deep
Front panel	106 mm wide x 128 mm high
Weight	3.5 kg
Operating temp	+0 ° to +40 °C
Storage temp	-30 ° to +70 °C
Max ambient operating humidity	90% RH non-condensing at 40 °C
Max operating altitude	3000 m
Electronic Design	EN 61010-1
Electromagnetic Compatibility	EN 61326 Industrial Location, Class B Emissions
Enclosure rating	IP20

Ordering Information

Product Description	Order No.
TIC Turbo & Instrument Controller 100 W RS232	D39721000
TIC Turbo & Instrument Controller 200 W RS232	D39722000
TIC Turbo Controller 100 W RS232	D39711000
TIC Turbo Controller 200 W RS232	D39712000
Accessories & Spares	Order No.
TIC Profibus Communications Module	D39754000
XDD/DX/EXDC Extension Cable 1m	D39700835
XDD/DX/EXDC Extension Cable 2m	D39700836
XDD/DX/EXDC Extension Cable 5m	D39700837
Linecord 2M UK Plug	D40013025
Linecord 2M North Euro Plug	D40013030
Linecord 2m With US Plug	D40013120
0.5M Active Gauge Cable	D40001005
1M Active Gauge Cable	D40001010
3M Active Gauge Cable	D40001030
5M Active Gauge Cable	D40001050
10M Active Gauge Cable	D40001100

TIC Relay Boxes



Two relay boxes are available for use with our TIC controllers:

- A small backing pump relay box is compatible with TIC turbo only and turbo and instrument controllers

- A small backing pump and instruments relay box is compatible with TIC turbo and instrument controllers

The small backing pump relay boxes are able to control mains backing pumps up to RV12/XDS10. The relay box also controls a mains heater band and backing line isolation valve. In addition the small backing pump and instrument relay box includes three 250 V a.c. 3 A changeover relays, which are activated by the gauge open collector set point outputs.

Features & Benefits

- Enables TIC to control mains backing pumps, up to and including XDS10 and RV12.
- Provides interfaces for a turbo heater band, a backing line isolation valve and a logic bypass. All relay boxes include a logic bypass facility for further system integration.
- TIC relay is packaged in a compact case and may be panel or rack (¼ 19inch rack 3U) or bench mounted.
- TIC relay will operate from mains supplies with voltages up to 240 V ac.

Dimensions

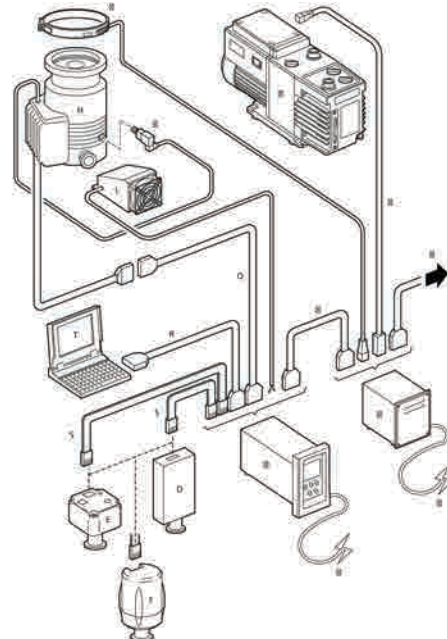

A	TIC200 turbo and instrument	K	TAV5 vent valve
B	Mains cable / line cord	L	ACX air cooler
C	Relay box	M	TIC logic interface cable
D	APG100 Pirani gauge	N	IEC320 M/F cable
E	AIGX Ion gauge	P	TIC logic interface cable
F	AIM Penning gauge	Q	XDD/IX/EXDC extension cable
G	XDS scroll pump	R	TIC RS232 interface cable
H	EXT/nEXT turbopump	S	Active gauge cable
J	BX heater band	T	PC with RS232 interface

Technical Data

Mains input	
Connector type	CEE/IEC320 inlet
Max rating	240V a.c.
Earth stud	M4
Heater band outlet	
Connector type	CEE/IEC320 inlet
Max rating	240V a.c. 1A
Fuse	20mm x 5mm, 250V, 1A type F
Backing pump outlet	
Connector type	CEE/IEC320 inlet
Max rating	240V a.c. 10A
Fuse	20mm x 5mm, 250V, 10A type T
Setpoint connector	
Connector type	12-way positronic PLC plug
Max rating	250V a.c. or 30V d.c., 3A (resistive)
Mating half (supplied)	12-way positronic PLC socket with hood
Backing line isolation valve connector	
Connector type	3-way DIN socket
Max rating	24V d.c. 0.5A
Lead type	3 core 0,5mm ²
Weight	695g
Operating temperature	+0°C to +40°C
Storage temperature	-30°C to +70°C
Max ambient operating humidity	90% RH non-condensing at 40°C
Max operating altitude	3000m
Electronic design	EN61010-1
Enclosure rating	IP20

Ordering Information

Product Description	Order No.
TIC Relay Box Sml Bkg	D39711805
TIC Relay Box Inst & Sml Bkg	D39721806
Accessories & Spares	Order No.
Linecord 2M North Euro Plug	D40013030
Linecord 2M UK Plug	D40013025
Linecord 2m With US Plug	D40013120
TIC Logic Interface Cable 2m	D39700833
TIC RS232 Interface Cable 2m	D39700834
XDD/DX/EXDC Extension Cable 1m	D39700835
XDD/DX/EXDC Extension Cable 2m	D39700836
XDD/DX/EXDC Extension Cable 5m	D39700837

EXT and nEXT Accessories

Pump-to-Controller Extension Cables

EXT75DX and nEXT pumps come as standard with a 1 m cable fitted. Where you wish to mount the pump further away from the controller, an extension cable is required. They are available in 1, 3 and 5 m lengths, to suit your installation.

Ordering Information

Product Description	Order No.
1 m cable	D39700835
3 m cable	D39700836
5 m cable	D39700837

Air-Cooler

An air-cooler is used to cool a turbo pump when a suitable cooling-water supply is not available or for a pump in a mobile pumping system. The air-cooler is an enclosed electrical fan and fixing bracket assembly which is easily fitted to bolt holes in the base of the pump. The air-cooler has a 24 V d.c. motor which can be powered and controlled from a rear panel socket on the EXC/TIC Controller or nEXT/DX pump. It is supplied with 3 m of electrical cable.

nEXT air coolers are also available with a phoenix connector to plug directly into the pump via short cable.

Ordering Information

Product Description	To Fit Pumps	Order No.
ACX75	EXT75DX	B58053075
ACX555H	EXT556H	B58053561
nEXT Axial air cooler	nEXT240/300/400	B58053185
nEXT Radial air cooler	nEXT240/300/400	B58053175
nEXT Axial air cooler with connector	nEXT240/300/400	B58053180
nEXT Radial air cooler with connector	nEXT240/300/400	B58053170

BX Bakeout Band

Use a BX bakeout band to increase the rate of degassing of the pump body to achieve faster pump down and lower ultimate pressure. Bakeout bands are only fitted to CF flanged pumps and/or intended for use in ultra high vacuum systems.

Bakeout bands are available for use with 110-120 or 220-240 V a.c. electrical supplies and can be powered from a rear panel socket on the EXC/TIC Controller. It is supplied with 3 m cable and mating CE22 connector.

Ordering Information

Product Description	To Fit Pumps	Order No.
Contact Edwards for ordering information		

PRX10 Purge-Restrictor

The PRX10 purge-restrictor is used to set the flow-rate of purge gas into the (n)EXT pump. All of the (n)EXT pumps have a purge-port to allow you to purge the motor and bearing cavity with dry nitrogen or another inert gas. Fit a vent-port adaptor to the purge-port of the pump to convert it from 1/8 inch BSP to DN10NW, before you use the PRX10.

Ordering Information

Product Description	Order No.
PRX10 purge-restrictor	B58065001

TAV Vent-Valve

The TAV vent-valves are 24 V d.c. solenoid operated valves which you can use to vent your vacuum system with atmospheric air or dry nitrogen when you switch off the (n)EXT pump. The valves are supplied with a sintered bronze inlet-filter, a riffled hose connector, 3 m of electrical cable and a DN10NW adaptor. The vent-valves can be powered and controlled from a rear panel socket on the EXC/TIC Controller or directly on DX/nEXT. You can either use your TAV vent-valve to replace the manual vent-valve supplied with the (n)EXT pump, or adapt it to fit any other suitable port on the vacuum system upstream of the turbomolecular pump.

Dimensions

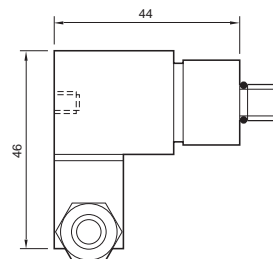

Ordering Information

Product Description	Order No.
TAV5 vent-valve	B58066010
TAV6 vent-valve	B58066020

Vent-Port Adaptor

This 1/8 inch BSP male to DN10NW adaptor can be used to replace the TAV5 vent-valve or the manual vent-valve fitted to the EXT pumps. It allows the threaded vent-port or purge port on the pump to be converted to a DN10NW flange.

The vent-port adaptor is supplied with a removable flow-restrictor and an O-ring to seal the adaptor to the pump.

Ordering Information

Product Description	Order No.
Vent-port adaptor	B58066011

Vibration Isolator

A vibration isolator can be fitted to the inlet-flange of the (n)EXT pump to reduce the transmission of the small amount of vibration generated by the pump to your vacuum system. The vibration isolator has two flanges separated by a flexible stainless steel bellows and an outer rubber anti-vibration collar.

The vibration isolator is designed for use with vertically mounted pumps only.

Ordering Information

To Fit Pump Inlet-Flange	Order No.
DN63CF	B58101000
DN63ISO-K	B58115000
DN100ISO-K	B58120000
DN160ISO-K	B58125000
DN100CF	B58105000
DN160CF	B58110000

VRX Vent-Restrictor

Fit a VRX vent-restrictor to your (n)EXT pump if you will vent the pump when the pump speed is above 50% of full rotational speed. The vent-restrictor restricts the flow-rate of the vent gas into the (n)EXT pump. You can also use the VRX to replace the standard restrictor supplied with the PRX10 purge restrictor to obtain a different purge rate.

You can fit the vent-restrictor to the TAV vent-valve, to the vent-port adaptor or directly to the vent or purge port of the pump.

Ordering Information

VRX Vent-Restrictor	Orifice Diameter (mm)	Order No.
VRX10	0.1	B58066021
VRX20	0.2	B58066022
VRX30	0.3	B58066023
VRX50	0.5	B58066024
VRX70	0.7	B58066025

Water-Cooler

A water cooler is used to cool a turbo pump where ambient temperatures are above 35°C, where high gas flows are required or where backing pressure is high.

For EXT75DX and EXT556H pumps the water cooler is fitted with 6mm OD nozzle connectors. For nEXT pumps the water cooler is supplied with push fit connectors to suit a 10mm OD pipe.

Ordering Information

Product description	Pump	Order No.
nEXT water cooler	nEXT240/300/400	B80000815
WCX water-cooler		
WCX250	EXT75DX	B73600121
WCX555H	EXT556H	B58067003

(n)EXT Spares

Each (n)EXT pump is supplied with an inlet seal and inlet screen. These items may also be ordered as spares.

Ordering Information

Product Description	Pump Type	To Fit Inlet Flange Size	Order No.
Inlet flange seals with integrated inlet screen			
100 coarse	nEXT240/300	DN100ISO	B81000808
100 fine	nEXT240/300	DN100ISO	B81000809
160 coarse	nEXT400	DN160ISO	B80000825
160 fine	nEXT400	DN160ISO	B80000826
ISX inlet-screen			
100 coarse	nEXT240/300	DN100CF	B80000821
100 fine	nEXT240/300	DN100CF	B80000822
160 coarse	nEXT400	DN160CF	B80000823
160 fine	nEXT400	DN160CF	B80000824
63	EXT75DX	DN63ISO-K, DN63CF	B72240860
160 coarse	EXT556H	DN160ISO-K, DN160CF	B58051007
160 fine	EXT556H	DN160ISO-K, DN160CF	B58051008
Inlet flange seals			
DN40NW Co-Seal, fluoroelastomer			B27158453
ISO63 Trapped O-ring, fluoroelastomer			B27158170
63CF copper compression gasket (pack of 10)			C10007490
100CF copper compression gasket (pack of 10)			C10009290
160CF copper compression gasket (pack of 5)			C10011290

nEXT bearing service parts and tools

On nEXT it is possible for end-users to change the oil cartridge and bearing in the field, using basic workshop tools and an Edwards tool kit. Service parts and tools are listed below.

Ordering Information

Product description	Order No.
Oil cartridge tool kit	B80000812
Bearing tool kit	B80000805
Oil cartridge	B80000811
Bearing and oil cartridge	B80000810

T-Station 75

2

Page
72



The T-Station 75 is Edwards's new entry level Turbopumping system. It combines our proven EXT75DX with a choice of either an oil sealed E2M1.5 backing pump or an XDD1 diaphragm pump where a totally dry solution is desired.

The T-Station comes with our new TAG (Turbo and Active Gauge) controller fitted as standard which enables single button start/stop of the system, the ability to control one of our Active Gauges*, vent valve control*, and delayed start to either time or pressure if a gauge is fitted making the T-Station ideal for general laboratory needs.

* Gauges and TAV5 vent valve must be purchased separately.

Features & Benefits

- Fully assembled and ready to use
- Control of turbopump, backing pump and optional gauge from integrated controller
- NW40, ISO63 or CF63 inlet flanges
- Choice of backing pumps, E2M1.5 oil sealed pump T-Station 75W or XDD1 diaphragm pump T-Station 75D
- Delayed turbo start option for pumping larger volumes

Dimensions

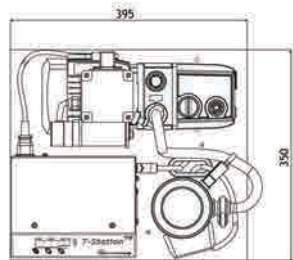
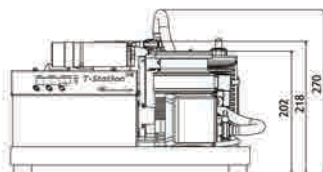

T-Station 75D

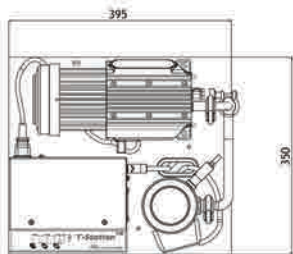
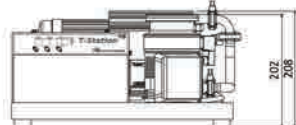

T-Station 75D

Applications

- General laboratory applications
- Spectroscopy
- Surface analysis
- Small coating systems
- Vacuum tube manufacturing

Ordering Information

Product Description	Order No.
T-Station 75D NW40 200-230V 50/60Hz	TS75D1001
T-Station 75D NW40 100-120V 50/60Hz	TS75D1002
T-Station 75D ISO63 200-230V 50/60Hz	TS75D2001
T-Station 75D ISO63 100-120V 50/60Hz	TS75D2002
T-Station 75D CF63 200-230V 50/60Hz	TS75D3001
T-Station 75D CF63 100-120V 50/60Hz	TS75D3002
T-Station 75W NW40 200-230V 50/60Hz	TS75W1001
T-Station 75W NW40 100-120V 50/60Hz	TS75W1002
T-Station 75W ISO63 200-230V 50/60Hz	TS75W2001
T-Station 75W ISO63 100-120V 50/60Hz	TS75W2002
T-Station 75W CF63 100-120V 50/60Hz	TS75W3002
T-Station 75W CF63 200-230V 50/60Hz	TS75W3001
Accessories & Spares	Order No.
0.5M Active Gauge Cable	D40001005
1M Active Gauge Cable	D40001010
2m electrical supply cable for 1-ph pumps, no plug	A50508000
2m electrical supply cable for 1-ph pumps, North America/Japan plug	A50507000
2m electrical supply cable for 1-ph pumps, North European plug	A50506000
2m electrical supply cable for 1-ph pumps, UK, Three-pin plug	A50505000
3M Active Gauge Cable	D40001030
5M Active Gauge Cable	D40001050
AIM-X Active Inverted Magnetron Gauge	D14642000
APG100 Active Pirani Vacuum Gauge	D02603000
APGX-H Active Linear Convection Gauge	D02391000
Model EMF3 mist filter	A46220000
TAV5 Vent Valve 24V DC 1/8 Bsp	B58066010
WRG-S Active Wide Range Gauge	D14701000

Technical Data

Pumping Speed for N₂

NW40 42 ls⁻¹

ISO63/CF63 61 ls⁻¹

Compression ratio for N₂ >1 x 10¹¹

Backing pump speed @ 50Hz

E2M1.5 1.6 m³ h⁻¹

XDD1 1.2 m³ h⁻¹

Ultimate pressure <5 x 10⁻⁸ mbar

Inlet flange NW40, ISO63 or CF63

Exhaust flange

E2M1.5 11mm OD Nozzle or 3/8 inch BSP

XDD1 Fitted silencer or 1/8 inch BSP

Weight

E2M1.5 22 kg / 48 lb

XDD1 18 kg / 40 lb

Noise level 55.4 dB(A)

Leak tightness <1 x 10⁻⁶ mbar ls⁻¹

Operating temperature range 10 to 40°C / 50 to 104°F

nEXT Turbopumping Stations

Our new range of nEXT turbopumping stations build on our previous generation, but with a simplified ordering matrix and expanded range to include turbopumps with speeds from 42 l s⁻¹ to 400 l s⁻¹.

For pumping speeds from 42 l s⁻¹ to 66l/s we offer our trusted EXT75DX pump with a choice of various wet and dry backing pumps and a Turbo and Instrument TIC100.

For pumping speeds of 240 l s⁻¹ to 400 l s⁻¹ the new turbopumping stations are based on our nEXT pumps offering the additional flexibility of end-user serviceability plus a choice of backing pumps and a Turbo and Instrument TIC200.

Turbopumping stations fitted with E2M1.5 or RV pumps come with an EMF mist filter fitted, and those fitted with our class leading XDS scroll pumps have an isolation valve fitted between the turbopump and backing pump as standard.

All turbopumping stations include 4 locking castor wheels, a bench-top mounting kit, built in air cooling and come configured to suit a wide variety of applications such as:

- UHV systems
- Beam lines
- Load locks
- Surface science
- High energy physics

Features & Benefits

- Fully assembled and ready to use
- Where nEXT is fitted the turbopump is fully end user-serviceable
- Control of the turbopump, backing pump and gauges from the integrated TIC
- Serial communication control available with RS232 and RS485 (Windows software included)
- Dry pumping options with XDD1, XDS5 and XDS10



Ordering Information

Turbopump *
M EXT75DX
B nEXT240D
C nEXT300D
D nEXT400D

Inlet Flange *
1 DN40NW (EXT75DX)
2 DN63ISO-K (EXT75DX)
3 DN63CF (EXT75DX)
4 DN100ISO-K (nEXT240/300)
5 DN100CF (nEXT240/300)
6 DN160ISO-K (nEXT400)
7 DN160CF (nEXT400)

Backing Pump
1 E2M1.5 †
2 RV5
3 RV12
A XDD1
B XDS5
C XDS10

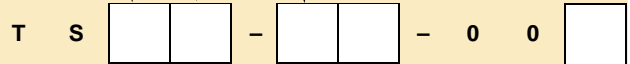

Vent Option
 Manual vent **0**
 TAV5 vent valve W **1**

Electrical Supply
 220-240 V 50/60 Hz (Europe) **1**
 110-120 V 50/60 Hz (USA) **2**
 200 V 50/60 Hz (Japan) **3**
 220-240 V 50/60 Hz (UK) **4**

* Turbopump and inlet flange must match as shown
 † For Japan low volts on E2M1.5 please order the USA voltage variant, for all other pumps please order Japan version and specify low volts on your order

STP Magnetically Levitated Turbomolecular Pumps

In April 2002, Edwards Acquired the Turbomolecular Pump Business of Seiko Instruments, Inc.

- Distributed and supported globally by Edwards for nearly twenty years
- Designed by continuous improvement on existing proven reliable technology
- Advanced materials and designs provide:
 - Class leading performance
 - Low vibration
 - Guaranteed reliability
 - Low cost of ownership
- The broad product range covers all potential turbo pump applications.
- Qualified by all major semiconductor OEM's
- Used in all major semiconductor fabrication plants
- Installed base of over 80000 units, 85% in the semiconductor industry



Key Features

- Multi-axis magnetic bearing system
- High Throughput versions for high flow processes
- Low vibration characteristics
- Advanced controller technology
- Full interfacing capability

Features & Benefits

- Improved pumping performance
 - Optimised for semiconductor process pressures
 - Maximised gas throughput for each flange size
 - Applications specific models
- New generation universal controllers
- Compact (1/2 rack) controller
 - Auto tune enabling "mix and match" pumps
 - Integrated TMS control
 - Improved diagnostics
- High power d.c. motor drive
 - Fast ramp-up time
 - Self regeneration upon power failure, eliminating the need for batteries



Edwards is a leader in clean and dry vacuum technology. The first STP pumps were sold in 1983 and there are now over 80000 installations worldwide. 85% are operating on semiconductor process tools where they demonstrate exceptional levels of reliability. STP pumps are the first choice for applications demanding high up-time, hydrocarbon-free pumping, minimal maintenance and low vibration.

- Proven reliability.
- Clean oil-free high vacuum.
- Complete range from 300 to 4500 l s⁻¹.
- Application specific models.
- Very low noise and vibration.
- Low cost of ownership.
- Virtually maintenance free.
- Installation in any orientation.
- Full remote control interface.
- Supported globally by Edwards

Proven Magnetic Bearing Technology

The rotor is entirely suspended by magnetic bearings so all contact between the rotor and the remainder of the pump is eliminated. As well as giving very low vibration, the elimination of contact means no bearing wear and no requirement for consequent pump maintenance.

STP Range



UHV Series The Ultra High Vacuum series of magnetically levitated turbo molecular pumps are the products of choice for the semiconductor, surface science or high energy physics industries. They offer unrivalled reliability, performance, cleanliness and class leading low vibration levels. The pumps are all d.c. powered, eliminating the need for batteries, they use a half rack controller which features auto-tuning and advanced diagnostic features. The range contains pumps with speeds from 300 l s⁻¹ to 1000 l s⁻¹ all of which are available in ISO or CF flange variants.



High Throughput Series The high throughput series of magnetically levitated turbo pumps generate the high gas flows required by the current generation of semiconductor etch, ion implant and LCD systems. All the pumps feature a five active axis magnetic bearing system and a d.c. drive for increased robustness and stability. They use a Holweck stage to provide advanced throughput performance. They operate via a half rack controller with auto-tuning, advanced diagnostics and an integrated temperature management system. The range operates with throughput speeds from 300 l s⁻¹ to 1300 l s⁻¹.



Advantage Series The new Advantage series of magnetically levitated turbo pumps have been designed to provide the highest levels of throughput required by the next generation of semiconductor etch and CVD processes. They have been developed, using continuous improvement techniques, from the ultra reliable, high performance H series of products. Their advanced rotor design combined with selection of the best materials has allowed the creation of the next generation of high throughput turbo pump inside the same footprint as many of the existing models. The range contains pumps with throughput speeds from 800 l s^{-1} to 4500 l s^{-1} .

STP Features

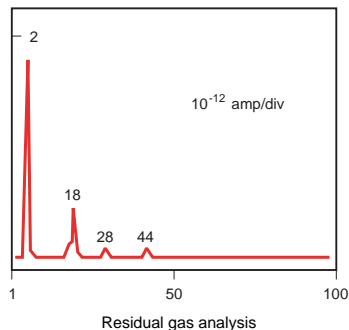

Oil Free All STP turbomolecular pumps are oil free. The use of magnetic bearings eliminates all hydrocarbon lubricants ensuring no contamination of the vacuum process from the turbomolecular pump. This feature is vital in the semiconductor industry (where device densities are constantly increasing) and in surface science or high energy physics applications (where even minute degrees of contamination disrupt measurements).

Maintenance Free Unlike conventional mechanical bearings, magnetic levitation means there is no frictional contact, eliminating sources of wear and vibration. This feature enables STP turbomolecular pumps to run for years with virtually no maintenance, reducing annual operating costs to a minimum and ensuring maximum up-time is achieved. This maintenance free feature can be particularly beneficial on processes producing chemical or radioactive contamination.

Vibration Free Magnetic levitation of the rotor results in an extremely low level of noise and vibration. Peak-to-peak vibration level is less than $0.02 \mu\text{m}$. This amplitude remains constant throughout the life of the pump and is free from troublesome sub-harmonics.

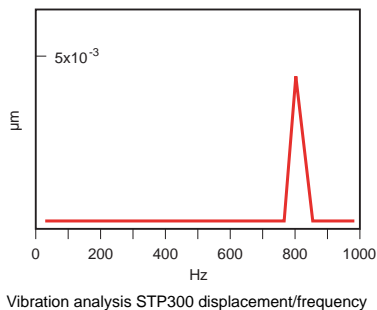

Automatic Balancing System (ABS) ABS is a unique patented development of 5-axis technology. If any rotor imbalance is introduced (by deposition of process by-products, for example), sensors in the pump detect changes in the rotor motion and compensate the magnetic bearing fields to allow the rotor to spin on its natural inertial axis. This minimizes the vibration transmitted to the inlet flange. ABS works at all pump rotational speeds.

Safety Backup Bearings STP pumps have dry lubricated axial and radial mechanical bearings as safety backup bearings. These support the rotor and protect the pump in the event of a total disruption of magnetic suspension or a massive air inrush which overcomes the magnetic bearing stiffness. These high precision ball bearings are dry lubricated and are not in contact with the rotor during normal operation.



Optimised Rotors The multistage pure bladed rotors in the UHV pumps provide the high vacuums required for clear beamlines on CD SEM machines, mass spectrometers and ion implanters. They provide optimum pumping performance with excellent light gas compression ratios.



Compound Rotors The high throughput pumps incorporate a Holweck drag stage that increases the pumps throughput at low pressure.



Advanced Series Compound Rotors The advanced series pumps have a redesigned compound rotor, the materials of manufacture have been improved to reduce the clearances within the pump, the rotors have an advanced 3D design and the Holweck stage has been redesigned to increase the throughput.



Corrosion Resistant To ensure a high level of resistance to corrosion, the corrosion resistant (C) and high throughput (H-C) pumps have nickel coated rotors/stators and pump internals suitable for ion implantation and plasma etching. Further enhanced levels of protection are available on request.



Nitrogen Purging The corrosion resistant (C) pumps and the high throughput (H-C) pumps have a nitrogen purge facility, a constant flow of nitrogen through the pump dilutes corrosive gases minimising their damage to the pumps motor and sensor coils.



TMS System The Edwards Temperature Management System is available on a wide range of turbo pumps. It is designed to optimize the temperature within the pump, dramatically reducing the particle condensation within. This will not only considerably enhance the performance of the pump under harsh process conditions, but also increase its operational life.

Applications

Semiconductor Fabrication STP turbomolecular pumps are the number one choice for the world's leading semiconductor etch and implant manufacturers. The pumps are installed on the harshest applications (for example, metal etch) and demonstrate exceptional levels of reliability.

- Plasma etch (chlorine, fluorine and bromine chemistries) for metal (aluminium), tungsten and dielectric (oxide) and polysilicon
- Electron cyclotron resonance (ECR) etch
- Film deposition CVD, PECVD, ECRCVD, MOCVD
- Sputtering
- Ion implantation source, beam line pumping end station
- MBE
- Diffusion
- Photo resist stripping
- Crystal/epitaxial growth
- Wafer inspection
- Load lock chambers

Scientific Applications STP pumps are used extensively in the world's foremost research and development institutes. The pumps satisfy stringent performance criteria and reliability expectations. They are also used in the following applications:

- Scientific instruments: surface analysis, mass spectrometry, electron microscopy
- High energy physics: beam lines, accelerators
- Radioactive applications: fusion systems, cyclotrons

STPs and the Environment

Reducing Energy Usage

Reducing global energy consumption is key in the fight against global warming. In addition to minimising the energy our production facilities and offices consume, our latest generation of Maglev turbo pumps enable our customers to meet their energy reduction targets. Future proofing against carbon taxes and potentially qualifying for 'Green Grants'.

Example:

In the production of coated products, existing vacuum pump energy could account for >50% of the total energy consumed by the process tool.

With an installed base of 95,000 maglev turbo pumps globally in a wide range of applications, Edwards STP Maglevs typically reduce the power consumption of Diffusion by < 90%.

Switching from Diffusion pumps to the latest Maglev turbos from Edwards on an 80 pump glass coating line will dramatically reduce your carbon footprint by over 3,000 tonnes of CO₂e / year.

Economising by switching to the new generation of STP Maglev turbo pumps

Benefits of STP Maglev turbo pumps

- Lower utility cost (Power and Water)
- No yearly services or oil changes
- Increased pumping performance
- Very low ambient noise and low vibration
- Reduced space requirements

Edwards HT10 Diffusion Pump vs Maglev Turbo Pump

	HT10 Diffusion Pump	STP iXA2205	% reduction	CO ₂ reduction per year (tonnes)
Power consumption	5.1 kW	0.3 kW*	94%	22.6 pa**
Water consumption	400 l h ⁻¹	120 l h ⁻¹	70%	

Edwards HT16 Diffusion Pump vs Maglev Turbo Pump

	HT16 Diffusion Pump	STP XA3203	% reduction	CO ₂ reduction per year (tonnes)
Power consumption	9 kW	0.3 kW*	97%	40.9 pa**
Water consumption	700 l h ⁻¹	120 l h ⁻¹	83%	

* at 300 sccm gas load power = 0.3 kW

** Energy source units vs kW/h

Kg CO₂ = kWh 0.537

Source: Department for Environment, Food, Rural Affairs, UK

Enabling Environmental Technology



Solar Cells A photovoltaic solar cell (PV cell) is a semiconductor device which, in the presence of light, generates electricity. Solar cells provide clean renewable energy, producing zero air pollution, hazardous waste or noise.



Biofuel Production The term biofuel applies to any solid, liquid or gaseous fuel produced from organic (once-living) matter. The word biofuel covers a wide range of products, some of which are commercially available today and some of which are still in research and development.



Glass Coating Vacuum coated glass is primarily used to control the solar generated thermal energy load on buildings. Multiple layers comprising exotic metal oxides create infrared reflecting properties. Reducing the heat load on buildings reduces the need for electrical power to run air conditioning in hot countries. Conversely in cold countries these same reflective properties are used to retain heat and reduce fuel used for heating. We expect the trend to accelerate as sustainable building principles become part of International building design standards.

Switching from just one 10 inch Diffusion pump to a Maglev turbo reduces the energy consumption by up to 95%, with a CO₂ reduction of 22.6 tonnes per year.



Steel Degassing Vacuum degassing (VD) and vacuum oxygen decarburisation (VOD) are used in the production of speciality steel alloys to reduce the levels of hydrogen, carbon and other impurities during the secondary steel making process.

Edwards dry mechanical vacuum pumps offer considerable energy savings compared to the traditional multi-stage steam ejector systems, backed with liquid ring pumps.



Solid State Lighting Solid-state lighting sources, such as light emitting diodes (LEDs), offer energy savings and environmental benefits compared to traditional incandescent or fluorescent lamps. In some cases they can offer a 95% energy saving over conventional lighting systems.

STP Turbo Pump Range

Integrated Controller

- 300 to 3300 l s⁻¹
- Compact design including a fully integrated controller
- Innovative, self-sensing magnetic bearing system
- Digital 5-axis control
- Can be configured to run corrosive processes
- Automatic Balancing System (ABS) standard
- Automatic Vibration Reduction (AVR) standard
- Reduces cabling requirement (no separate controller)
- Profibus[®] available
- IP54 rated

Ultra High Vacuum (UHV) Series

- 300 to 1000 l s⁻¹, <10⁻¹⁰ mbar (CF flange)
- Low vibration
- Highest reliability
- Maintenance free
- Harsh process compatible (C version)

UHV Low Vibration Series

- 300 to 500 l s⁻¹
- Built-in vibration isolator gives ultra low vibration performance
- Increased pumping performance
- Compact design
- Easy installation - one simple pump component solution
- Low magnetic field variants available

Advanced High Throughput Maglev Pumps

- 300 to 4500 l s⁻¹, 6 slm throughput class pump
- Advanced series rotor technology and 3D blade design
- The Holweck drag stage with reversed spiral for high gas throughput
- Digital 5-axis control
- Harsh duty compatible
- Class leading performance on ISO250
- Increased H₂, N₂ and Ar performances

STP-iX455 Turbomolecular vacuum pump



The STP-iX455 turbo-molecular pump features an innovative, magnetic bearing and motor drive system, providing a 50% reduction in vibration compared to previous generation turbo pumps. An integrated controller eliminates the need for a conventional, rack-mounted controller and interconnecting cables, and does not require water cooling. The pump features 450 ls^{-1} pumping speed for nitrogen. The STP-iX455 is an excellent fit for electron microscope, metrology, lithography and other vibration sensitive applications.

Features & Benefits

- Compact Design including a fully integrated controller
- Innovative, Self-Sensing magnetic bearing system
- Digital 5-axis control
- Vibration levels reduced by 50% compared to the existing turbo pumps
- Can be configured to run corrosive processes

Dimensions

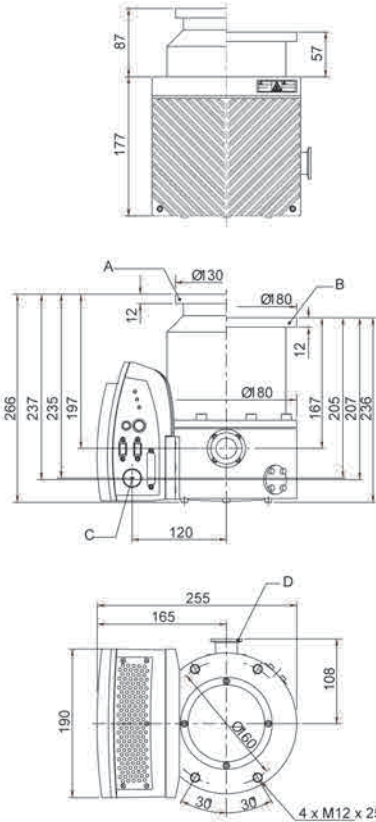

Inlet Flange	A	B
ISO100	130 (5.12)	12 (0.47)
DN100CF	152 (5.98)	21 (0.83)
VG100	182 (7.17)	12 (0.47)
ISO160	180 (7.09)	12 (0.47)
DN160CF	203 (7.99)	22 (0.87)
VG150	235 (9.25)	12 (0.47)

Applications

- Plasma etch (chlorine, fluorine and bromine chemistries) for metal (aluminum), tungsten and dielectric (oxide) and polysilicon
- Electron cyclotron resonance (ECR) etch
- Film deposition CVD, PECVD, ECRCVD, MOCVD
- Sputtering
- Ion implantation source, beam line pumping end station

Performance Curves

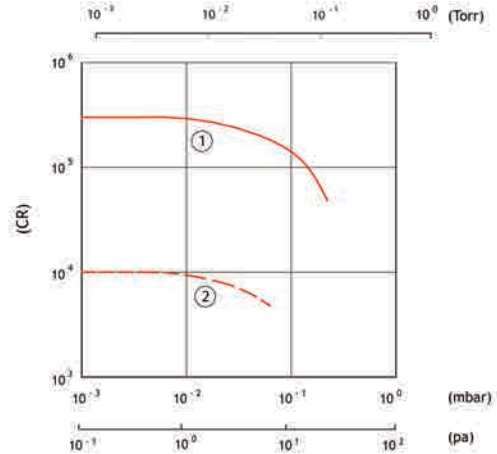

1. He 2. H₂

Compression Ratio CR vs Backing Pressure

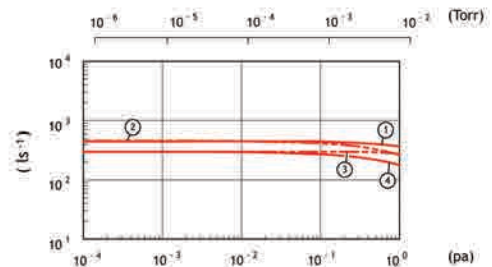

1. N₂ (450 ls^{-1}) 2. H₂ (460 ls^{-1}) 3. N₂ (300 ls^{-1}) 4. H₂ (300 ls^{-1})
(ISO160, VG150) (ISO160, VG150) (ISO100, VG100) (ISO100, VG100)

Technical Data

Inlet flange	ISO100K
Pumping Speed	
N ₂	300 ls ⁻¹
H ₂	300 ls ⁻¹
Compression ratio	
N ₂	>10 ⁸
H ₂	>1 x 10 ⁴
Ultimate pressure	6.5 x 10 ⁻⁶ order Pa
Max working pressure	1.3 x 10 ⁻¹ Pa
Allowable backing pressure	67 Pa
Rated speed	55000 rpm
Starting time	<6 min
Mounting position	Any orientation
Cooling method	Natural cooling (water cooling or air cooling when baking and gas pumping)
Lubricating oil	Not necessary
Backing pump	240 lmin ⁻¹
Leakage Magnetic Flux	
Axial direction	<100 m/Gauss
Radial direction	<100 m/Gauss
Ambient temperature range	0 to 40 °C
Storage temperature range	-25 to 55 °C
Weight	15 kg

Ordering Information

Product Description	Order No.
STP-iX455 Turbomolecular pump ISO100K	PT640Z010
STP-iX455 Turbomolecular pump ISO160K	PT640Z020
STP-iX455 Turbomolecular pump DN100CF	PT640Z050
STP-iX455 Turbomolecular pump DN160CF	PT640Z060
Accessories & Spares	Order No.
iDT-001 Display unit	PT64W1Z00
iPS240 Power supply	PT64W0Z00
STP-iX455-iPS240 interconnection cable 5 m	PT64Y0B20
STP-iX455-iPS240 interconnection cable 10 m	PT64Y0B30
STP-iX455-iPS240 interconnection cable 15 m	PT64Y0B40
STP-iX455-iPS240 interconnection cable 20 m	PT64Y0B50
Power supply cable for iPS240 3m	PT64Y0A10
Power supply cable for iPS240 5m	PT64Y0A20

STP-iXR1606 Turbomolecular vacuum pump



STP-iXR1606 series magnetically levitated turbo-molecular pump provides industry-leading performance and incorporates latest technology small power supply into the onboard control which is the same concept with STP-iXA2206/iXA3306 series. The pumping performance is improved by the newest developed revolutionary rotor design. This fully integrated product offers easy installation and small footprint as an all-in-one solution for all application tools.

Features & Benefits

- Eliminates connection cable between pump and control unit.
- Eliminates installation space and cost required by conventional rack type control unit.
- Compact design results in easy installation and small foot print.
- Highest pumping speed in the 8" TMP class, along with the STP-A1603.
- 32% reduced power consumption in the high gas flow area.

Dimensions

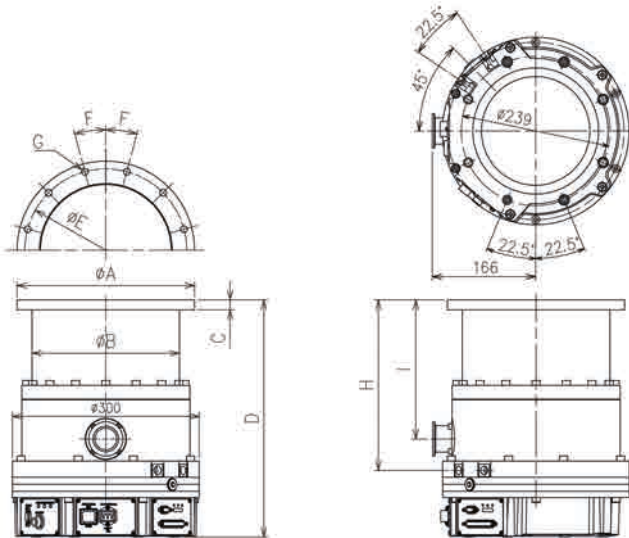

Inlet port flange	VG150	VG200	VG250	ISO160F	ISO200F	ISO250F	ICF203	ICF253	ICF305
OA	235	300	350	225	285	335	203	253	305
OB	237	237	237	237	237	237	237	237	237
C	15	16	16	15	16	16	22	25	28
D	420	380	380	420	380	380	420	418	380
OE	210	270	320	200	260	310	181	231.8	284
F	22.5	22.5	15	22.5	15	15	9	7.5	5.625
G	8-Ø12	8-Ø15	12-Ø15	8-Ø12	12-Ø11	12-Ø11	20-Ø8.4	24-Ø8.4	32-Ø8.4
H	313	273	273	313	273	273	313	311	273
I	263	223	223	263	223	223	263	261	223

Applications

- Glass Coating
- Solar PVD
- Industrial Sputtering

Performance Curves

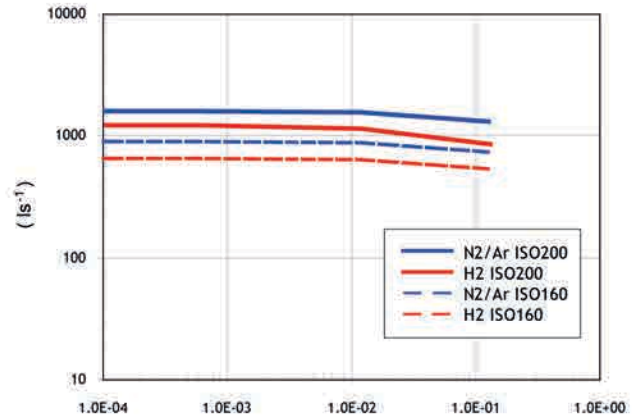

Technical Data

Intel Flange Size	VG150	VG200/VG250
	ISO160F	ISO200F/ISO250F
	ICF203	ICF253/ICF305
Backing port size	KF40	KF40
Pump Speed		
N ₂	900 ls ⁻¹	1600 ls ⁻¹
H ₂	600 ls ⁻¹	1200 ls ⁻¹
Compression ratio		
N ₂	>10 ⁸	
H ₂	1 x 10 ³	
Ultimate pressure	10 ⁻⁷ Pa (10 ⁻⁹ Torr)	
Allowable backing pressure	266 Pa (2 Torr)	
Max Gas size N2 (water cooled only)	4700 sccm	
	(7.94 Pam ³ s ⁻¹)	
Max Gas size Ar (water cooled only)	1800 sccm	
	(3.04 Pam ³ s ⁻¹)	
Rated speed	36,500 rpm	
Starting time	8 min	
Mounting position	Any orientation	
Input voltage	200 to 240 (± 10) V a.c.	
Maximum input power	750 VA	
Weight	48 kg	

Ordering Information

Product Description	Order No.
STP-iXR1606 ISO200F	YT790Z010
STP-iXR1606 VG200	YT790Z020
STP-iXR1606 ISO250F	YT790Z040
STP-iXR1606 ISO160F	YT790Z070
STP-iXR1606 VG150	YT790Z080
STP-iXR1606 ISO200F with Profibus	YT790Z100
STP-iXR1606 ISO250F with Profibus	YT790Z110
Accessories & Spares	Order No.
iDT-001 Display Terminal	YT79U1Z00
Power cable 5m	YT79Y0A00
Power cable 10m	YT79Y0A03
Power connector only	PTZ003114

STP-iXA2206C Turbomolecular vacuum pump



The STP-iXA2206 series magnetically levitated turbomolecular pump provides industry-leading performance and incorporates a small power supply into the onboard control unit – the latest technology of the well-established STP-iXA2205 series. The height of the pump is equal to the STP-A2203C and is also equal to the height of the STP-iXA2205 series without its power supply (iPS-1200). This fully integrated product offers easy installation and a small footprint as an all-in-one solution for all application tools.

Features & Benefits

- Compact design including a fully integrated controller
- Innovative, self-sensing magnetic bearing system
- Digital 5-axis control
- Vibration levels reduced by 50% compared to the existing turbo pumps
- Can be configured to run corrosive processes

Dimensions

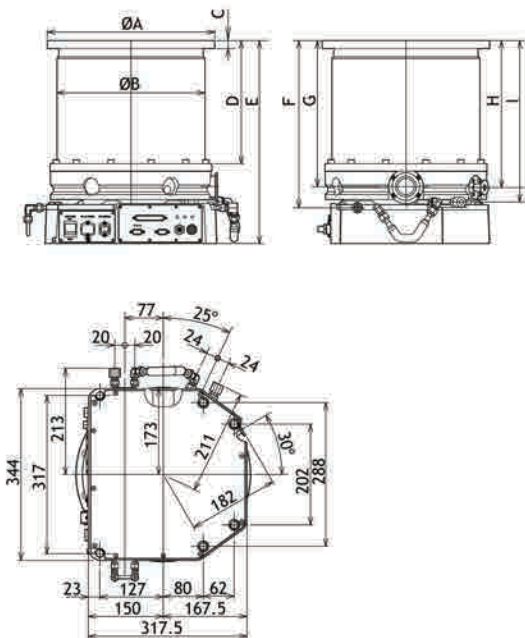

Inlet port flange	VG250	ISO250F	ICF305
OA	350	335	305
OB	296	296	296
C	18	16	28
D	235	245	275
E	395	405	435
F	312	322	352
G	281	291	321
H	283	293	323
I	322	332	322

Applications

- Plasma etch (chlorine, fluorine and bromine chemistries) for metal (aluminium), tungsten and dielectric (oxide) and polysilicon
- Electron cyclotron resonance (ECR) etch
- Film deposition CVD, PECVD, ECRCVD, MOCVD
- Sputtering
- Ion implantation source, beam line pumping and station

Performance Curves

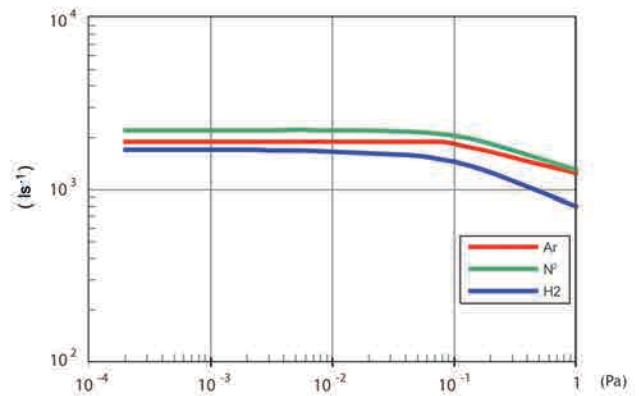

Technical Data

Inlet flange size	ISO250F/VG250/ICF305
Backing port size	KF40
Pump speed N ₂ /Ar	2200/1900 ls ⁻¹
Compression ratio N ₂ /H ₂	$>10^8 / 1 \times 10^4$
Ultimate pressure	10^{-7} Pa (10^{-9} Torr)
Allowable backing pressure	266 Pa (2 Torr)
Max gas flow N ₂ * (water cooled only)	3000 sccm ($5.07 \text{ Pam}^3 \text{ s}^{-1}$)
Max gas flow Ar * (water cooled only)	1400 sccm ($2.36 \text{ Pam}^3 \text{ s}^{-1}$)
Rated speed	27000 rpm
Run-up time to 90% rated speed	<8 minutes
Mounting position	Any orientation
Input voltage	200-240 V
Max input power (without TMS)	1200 VA
Weight	62 kg

* The maximum gas flow is applicable under conditions that N₂ or Ar gas is pumped continuously with water cooling temperature between 15-25 °C and the backing pump (10,000 l/min size) is used. It is changed on condition.

Ordering Information

Product Description	Order No.
STP-iXA2206C ISO250F	YT810Z010
STP-iXA2206C VG250	YT810Z020
STP-iXA2206C DN250CF	YT810Z030
STP-iXA2206C ISO250F with Profibus	YT810Z040
Accessories & Spares	Order No.
iDT-001 Display unit	YT63U1Z30
Power Cable 10M	PT35Y0A00
Power Cable 15m	B75030430
Power Cable 5m	B75030020

STP-iXA3306C Turbomolecular vacuum pump



The STP-iXA3306 series magnetically levitated turbomolecular pump provides industry-leading performance and incorporates a small power supply into the onboard control unit – the latest technology of the well-established STPiXA3305 series. The height of the pump is equal to the STP-XA2703/XA3203 and is also equal to the height of the STP-iXA3305 series without its power supply (iPS-1200). This fully integrated product offers easy installation and a small footprint as an all-in-one solution for all application tools.

Features & Benefits

- Compact design including a fully integrated controller
- Innovative, self-sensing magnetic bearing system
- Digital 5-axis control
- Vibration levels reduced by 50% compared to the existing turbo pumps
- Can be configured to run corrosive processes

Dimensions

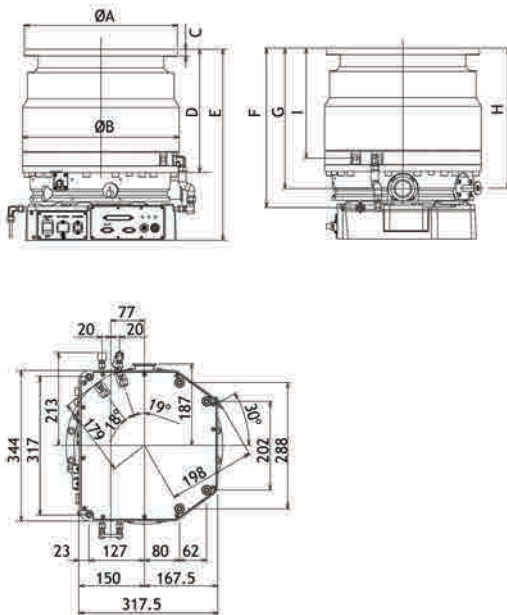

Inlet port/flange	VG250	ISO250F	VG300	ISO320F	ICF305	ICF356
ØA	350	335	400	425	305	356
ØB	358	358	358	358	358	358
C	15	15	18	20	28	28.5
D	281	281	242	242	286	281
E	435	435	396	396	440	435
F	363	363	325	325	368	364
G	320	320	282	282	325	321
H	319	319	281	281	324	320
I	251	251	212	212	256	251

Applications

- Plasma etch (chlorine, fluorine and bromine chemistries) for metal (aluminium), tungsten and dielectric (oxide) and polysilicon
- Electron cyclotron resonance (ECR) etch
- Film deposition CVD, PECVD, ECRCVD, MOCVD
- Sputtering
- Ion implantation source, beam line pumping and station

Performance Curves

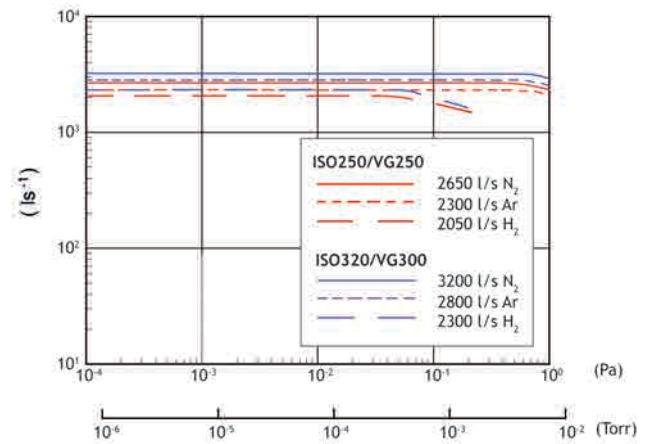

Technical Data

Inlet flange size	ISO250F / VG250 / ICF305
Backing port size	KF40
Pumping speed N ₂	2650 ls ⁻¹
Pumping speed Ar	2300 ls ⁻¹
Compression ratio N ₂ /H ₂	$>10^8 / 2 \times 10^3$
Ultimate pressure	10 ⁻⁷ Pa (10 ⁻⁹ Torr)
Allowable backing pressure	266 Pa (2 Torr)
Max gas flow N ₂ *(water cooled only)	4000 sccm (6.76 Pam ³ s ⁻¹)
Max gas flow Ar *(water cooled only)	2100 sccm (3.55 Pam ³ s ⁻¹)
Rated speed	27700 rpm
Starting time	<10 minutes
Mounting position	Any orientation
Input voltage	200-240 V
Max input power without TMS	1500 VA
Max input power with TMS	1800 VA
Weight	80 kg

* The maximum gas flow is applicable under conditions that N₂ or Ar gas is pumped continuously with water cooling temperature under 25° C and the backing pump (10,000 l/min size) is used. It is changed on condition.

Ordering Information

Product Description	Order No.
STP-iXA3306C ISO250F	YT820Z020
STP-iXA3306C VG250	YT820Z030
STP-iXA3306C ISO320F	YT820Z040
STP-iXA3306C VG300	YT820Z050
STP-iXA3306C ISO250F with Profibus	YT820Z060
STP-iXA3306C ISO320F with Profibus	YT820Z070
Accessories & Spares	Order No.
iDT-001 Display unit	YT63U1Z30
Power Cable 5m	B75030020
Power Cable 10M	PT35Y0A00
Power Cable 15m	B75030430

STP301 Turbomolecular Vacuum Pump



Edwards STP301 is for use in electron microscopes and semiconductor applications. Edwards rotor technology gives class-leading performance for maximum process flexibility. The STP301 has been approved for use by major equipment manufacturers in the scientific instrument, semiconductor and magnetic media industries.

This STP pump is supplied with an inlet screen.

For a complete installation order an STP pump, a controller, a connection cable and power cable.

Features & Benefits

- Advanced rotor technology
- Maximized process flexibility
- Oil free
- Low vibration
- High reliability

Dimensions

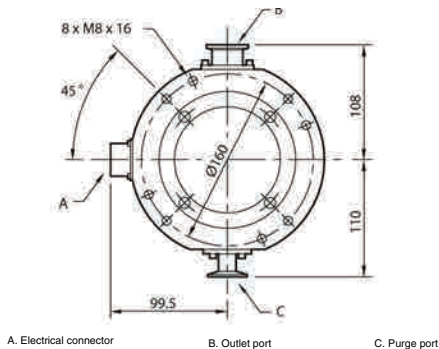
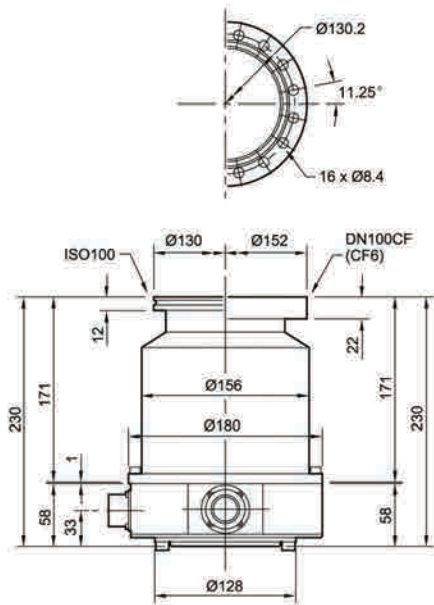

A. Electrical connector B. Outlet port C. Purge port

Applications

- Plasma etch (chlorine, fluorine and bromine chemistries) for metal (aluminum), tungsten and dielectric (oxide) and polysilicon
- Electron cyclotron resonance (ECR) etch
- Film deposition CVD, PECVD, ECRCVD, MOCVD
- Sputtering
- Ion implantation source, beam line pumping end station

Performance Curves

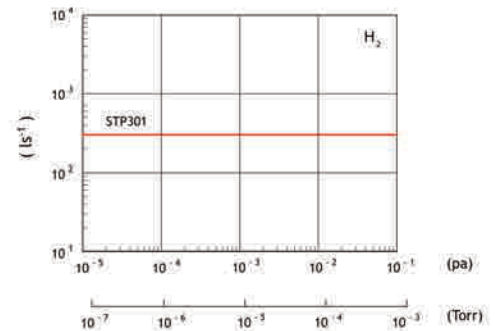
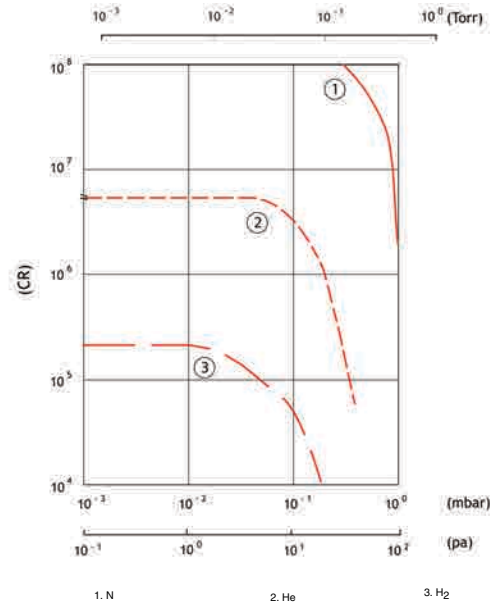

Technical Data

Inlet flange	ISO100, CF100
Outlet port	KF25
Pumping Speed	
N ₂	300 ls ⁻¹
H ₂	300 ls ⁻¹
Compression ratio	
N ₂	>10 ⁸
H ₂	>2 x 10 ⁴
Ultimate pressure with bake out heating (VG/ISO flange)	6.5 x 10 ⁻⁶ Pa (5 x 10 ⁻⁸ Torr)
Ultimate pressure with bake out heating (ICF flange)	10 ⁻⁸ Pa (10 ⁻¹⁰ Torr)
Maximum allowable inlet pressure (ambient cooled)	0.066 Pa (5 x 10 ⁻⁴ Torr)
Max continuous outlet pressure (ambient cooled)	13 Pa (0.1 Torr)
Rated speed	48000 rpm
Starting time	3 min
Maximum inlet flange temperature	120 °C
Input voltage	100 to 120 (± 10%) V a.c. or 200 to 240 (± 10%) V a.c.
Power consumption at start up	0.55 kVA
Pump weight	11 kg
Controller weight	7 kg

Ordering Information

Product Description	Order No.
STP301 ISO100 Inlet KF25 Outlet	B74830020
STP301 DN100CF Inlet	B74831010
STP301C ISO100 Inlet	B74871010
STP301C ISO100 inlet KF40 outlet	B74872000
STP301C DN100CF Inlet	B74881010
STP301C ISO100 inlet KF25 outlet	B74871000
Accessories & Spares	Order No.
SCU-21 Control unit	PT21Z0Z04
STP301/451 Water Cooling Coil	YT21CA001
STP301/451/603/1003 Air Cooler 100-120 VAC	YT011A003
STP301/451/603/1003 Air Cooler 200-240 VAC	YT011A005
STP straight connection cable, 3m	B70700010
STP straight connection cable, 5m	B70700000
Connection cable, 12m	PT21Y0B08
Type B P/Cab 3M UK Plug	A50505010
Type B P/Cab 3M Europe Plug	A50506010
Type B P/Cab 3M Ring Terminals	B70700090
Type B P/Cab 5M Ring Terminals	B70700040

STP-L301 Turbomolecular Vacuum Pump



Edwards corrosion resistant STP-L301(C) is for use in electron microscopes and semiconductor applications. Edwards rotor technology gives class-leading performance for maximum process flexibility.

The STP-L301(C) has been approved for use by major equipment manufacturers in the scientific instrument, semiconductor and magnetic media industries.

Features & Benefits

- Advanced rotor technology
- Maximized process flexibility
- Oil free
- Low vibration
- High reliability

Dimensions

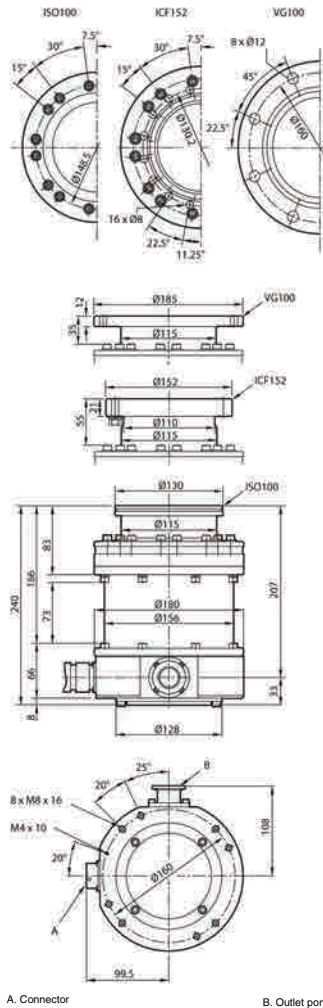

Applications

- Plasma etch (chlorine, fluorine and bromine chemistries) for metal (aluminum), tungsten and dielectric (oxide) and polysilicon
- Electron cyclotron resonance (ECR) etch
- Film deposition CVD, PECVD, ECRCVD, MOCVD
- Sputtering
- Ion implantation source, beam line pumping end station

Performance Curves

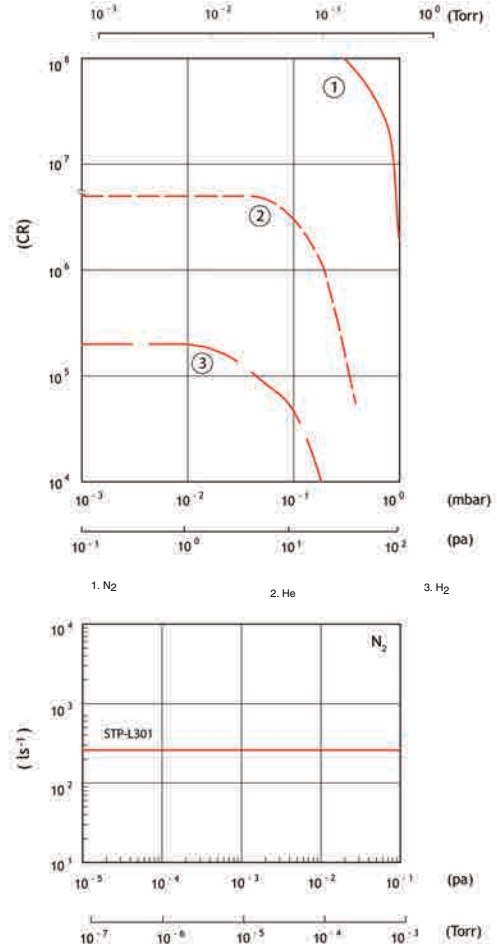

Technical Data

Inlet flange	ISO100, CF100
Outlet port	KF25
Purge port	KF10
Pumping Speed	
N ₂	260 ls ⁻¹
H ₂	290 ls ⁻¹
Compression ratio	
N ₂	>10 ⁸
He	5 x 10 ⁵
H ₂	2 x 10 ⁴
Ultimate pressure with bake out heating (VG/ISO flange)	6.5 x 10 ⁻⁶ Pa (5 x 10 ⁻⁸ Torr)
Ultimate Pressure with bake out heating (ICF flange)	10 ⁻⁸ Pa (10 ⁻¹⁰ Torr)
Max allowable inlet pressure ambient cooled	6.7 x 10 ⁻² Pa (5 x 10 ⁻⁴ Torr)
Max continuous outlet pressure ambient cooled	13 Pa (0.1 Torr)
Rated speed	48000 rpm
Starting time	3 min
Maximum inlet flange temperature	120 °C
Input voltage	100 to 120 (± 10) V a.c. or 200 to 240 (± 10) V a.c.
Power consumption at start up	0.55 kVA
Pump weight	13 kg
Controller weight	7 kg

Ordering Information

Product Description	Order No.
STP-L301C ISO100 Inlet	B75800010
STP-L301 ISO100 Inlet	B75800090
STP-L301 DN100CF Inlet	PT470Z000
STP-L301C DN100CF Inlet	PT47AZ030
Accessories & Spares	Order No.
SCU-21 Control unit	PT21Z0Z04
STP301/451 Water Cooling Coil	YT21CA001
STP301/451/603/1003 Air Cooler 100-120 VAC	YT011A003
STP301/451/603/1003 Air Cooler 200-240 VAC	YT011A005
STP straight connection cable, 3m	B70700010
STP straight connection cable, 5m	B70700000
Connection cable, 12m	PT21Y0B08
Type B P/Cab 3M Europe Plug	A50506010
Type B P/Cab 3M Ring Terminals	B70700090
Type B P/Cab 3M UK Plug	A50505010
Type B P/Cab 5M Ring Terminals	B70700040

STP603 Turbomolecular Vacuum Pump



Edwards STP603 is a new turbomolecular pump for use in the most advanced semiconductor applications. Edwards rotor technology gives class-leading performance for maximum process flexibility. This pump has been approved for use by major equipment manufacturers in the semiconductor and magnetic media industries.

Features & Benefits

- Advanced rotor technology
- Maximized process flexibility
- Oil free
- Low vibration
- High reliability

Dimensions

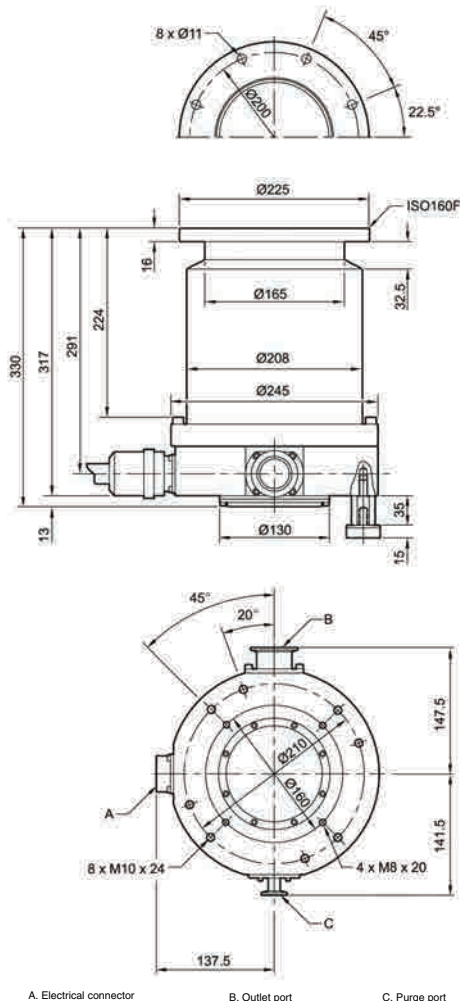

Applications

- Plasma etch (chlorine, fluorine and bromine chemistries) for metal (aluminum), tungsten and dielectric (oxide) and polysilicon
- Electron cyclotron resonance (ECR) etch
- Film deposition CVD, PECVD, ECRCVD, MOCVD
- Sputtering
- Ion implantation source, beam line pumping end station

Performance Curves

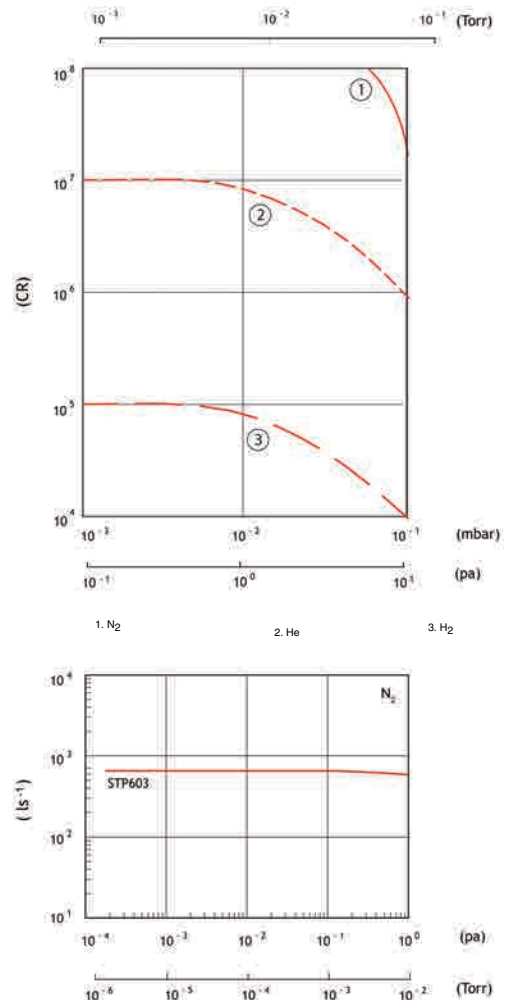

Technical Data

Inlet flange	ISO160F
Outlet port	KF40
Pumping Speed	
N ₂	650 ls ⁻¹
H ₂	550 ls ⁻¹
Compression ratio	
N ₂	>10 ⁸
H ₂	>10 ⁵
Ultimate pressure with bake out heating (VG/ISO flange)	6.5 x 10 ⁻⁶ Pa (5 x 10 ⁻⁸ Torr)
Ultimate Pressure with bake out heating (ICF flange)	10 ⁻⁷ Pa (10 ⁻⁹ Torr)
Max continuous outlet pressure	13 Pa (0.1 Torr)
Rated speed	35000 rpm
Starting time	6 min
Max inlet flange temp	120 °C
Input voltage	100 to 120 (± 10) V a.c. or 200 to 240 (± 10) V a.c.
Power consumption at start up	0.8 kVA
Pump weight	31 kg
Controller weight	9 kg

Ordering Information

Product Description	Order No.
STP603 ISO160F Inlet	YT39B0030
STP603C ISO160F Inlet	YT39B0110
STP603 DN160CF Inlet	YT390Z005
STP603C DN160CF Inlet	YT39AZ002
Accessories & Spares	Order No.
SCU-800 Control unit	YT49Z2Z00
Water cooling coil	YT170A001
STP301/451/603/1003 Air Cooler 100-120 VAC	YT011A003
STP301/451/603/1003 Air Cooler 200-240 VAC	YT011A005
Vibration Isolator ISO200-K	B58061000
Power Cable 5m	PT49Y0A00
Power Cable 10m	PT49Y0A01
Connection Cable 3m	B75130050
STP straight connection Cable, 5m	B75130020
STP straight connection cable ,10m	B75130060

STP1003 Turbomolecular Vacuum Pump



Edwards corrosion resistant STP1003C is a new turbomolecular pump for use in the most advanced of semiconductor applications. Edwards's rotor technology gives class-leading performance for maximum process flexibility. This pump has been approved for use by major equipment manufacturers in the semiconductor and magnetic media industries.

Features & Benefits

- Advanced rotor technology
- Maximized process flexibility
- Oil free
- Low vibration
- High reliability

Dimensions

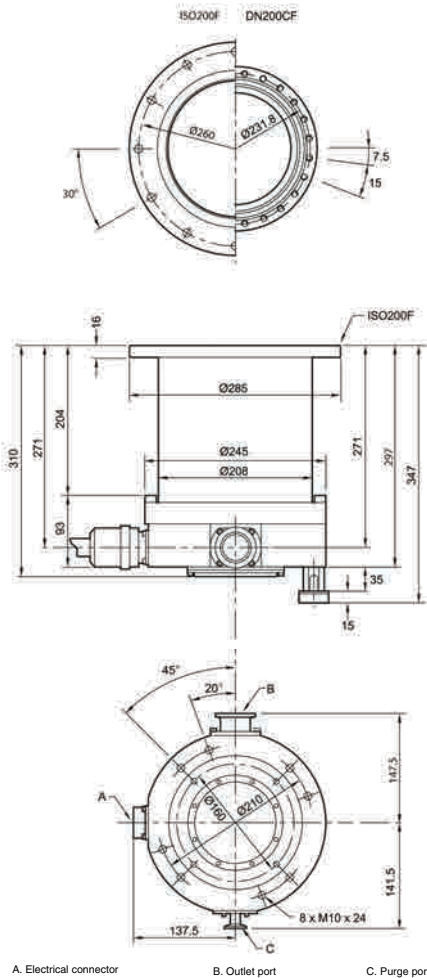

Applications

- Plasma etch (chlorine, fluorine and bromine chemistries) for metal (aluminum), tungsten and dielectric (oxide) and polysilicon
- Electron cyclotron resonance (ECR) etch
- Film deposition CVD, PECVD, ECRCVD, MOCVD
- Sputtering
- Ion implantation source, beam line pumping end station

Performance Curves

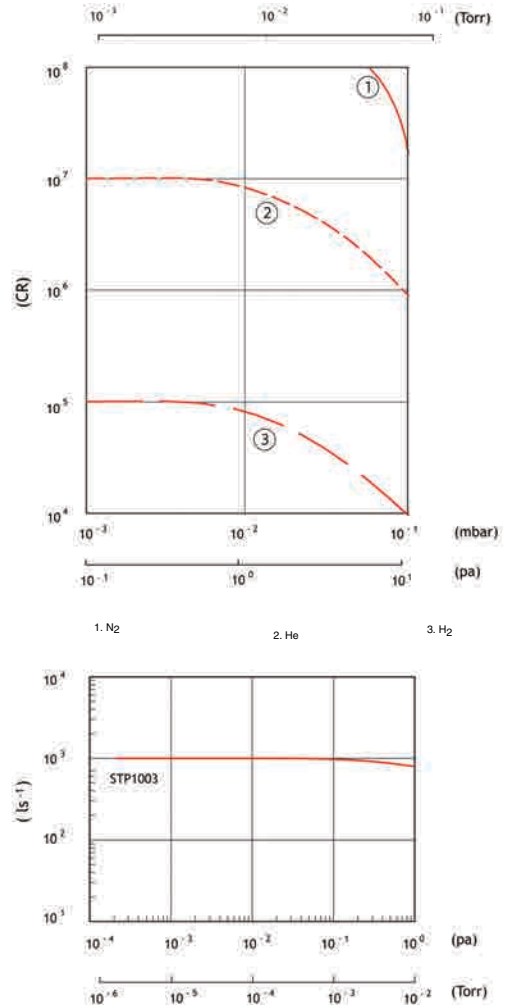

Technical Data

Inlet flange	ISO200F
Outlet port	KF40
Purge port	KF10
Pumping Speed	
N ₂	1000 ls ⁻¹
H ₂	800 ls ⁻¹
Compression ratio	
N ₂	>10 ⁸
H ₂	>10 ⁵
Ultimate pressure with bake out heating (VG/ISO flange)	10 ⁻⁷ Pa (10 ⁻⁹ Torr)
Ultimate pressure with bake out heating (ICF flange)	10 ⁻⁸ Pa (10 ⁻¹⁰ Torr)
Max continuous outlet pressure	13 Pa (0.1 Torr)
Rated speed	35000 rpm
Starting time	6 min
Max inlet flange temp	120 °C
Input voltage	100 to 120 (± 10) V a.c. or to 240 (± 10) V a.c.
Power consumption at Start up	0.8 kVA
Pump weight	31 kg
Controller weight	9 kg

Ordering Information

Product Description	Order No.
STP1003C ISO200F Inlet	YT39B0130
STP1003 ISO200F Inlet	YT390Z001
STP1003C DN200CF Inlet	PT39AZ003
STP1003 DN200CF Inlet	YT39B0010
Accessories & Spares	Order No.
SCU-800 Control unit	YT49Z2Z00
Water cooling coil	YT170A001
STP301/451/603/1003 Air Cooler 100-120 VAC	YT011A003
STP301/451/603/1003 Air Cooler 200-240 VAC	YT011A005
Vibration Isolator ISO200-K	B58061000
Power Cable 5m	PT49Y0A00
Power Cable 10m	PT49Y0A01
Connection Cable 3m	B75130050
STP straight connection Cable, 5m	B75130020
STP straight connection cable ,10m	B75130060

STPH301C Turbomolecular Vacuum Pump



Edwards high performance STPH301C turbomolecular pump has been designed for use in the harshest of semiconductor applications. The pumps field proven reliability and class-leading performance give maximum process flexibility. The STPH301C has been approved for use by major equipment manufacturers in the semiconductor and magnetic media industries.

Features & Benefits

- Advanced rotor technology
- Higher gas throughput
- Maximized process flexibility
- Oil free
- Low vibration

Dimensions

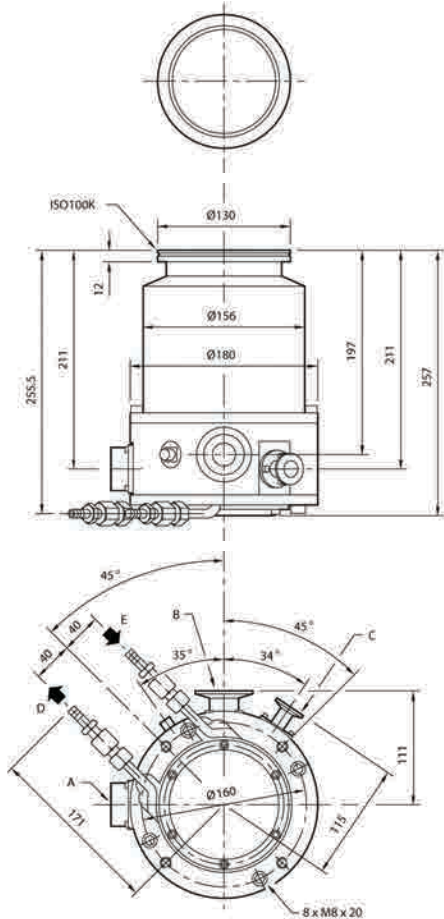

- | | | | | | |
|---|----------------------|---|------------------|---|------------|
| A | Electrical connector | B | Outlet port | C | Purge port |
| D | Cooling water out | E | Cooling water in | | |

Applications

- Plasma etch (chlorine, fluorine and bromine chemistries) for metal (aluminum), tungsten and dielectric (oxide) and polysilicon
- Electron cyclotron resonance (ECR) etch
- Film deposition CVD, PECVD, ECRCVD, MOCVD
- Sputtering
- Ion implantation source, beam line pumping end station

Performance Curves

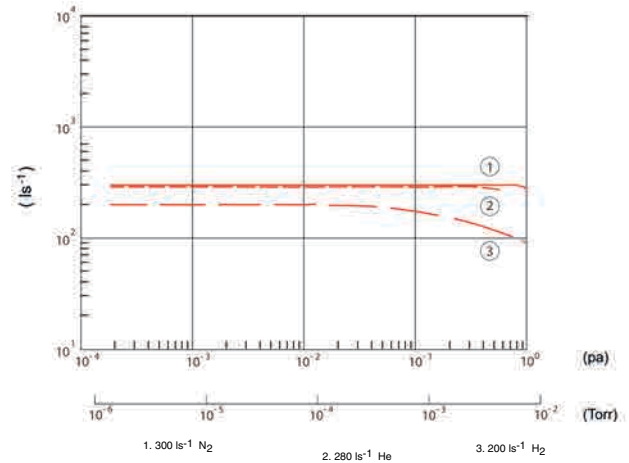

Technical Data

Inlet flange	ISO100K
Outlet port	KF40
Purge port	KF10
Water cooling fitting	PT1/4
Pumping Speed	
N ₂	300 ls ⁻¹
H ₂	200 ls ⁻¹
Compression ratio	
N ₂	>10 ⁸
H ₂	10 ³
Ultimate pressure with bake out heating	10 ⁻⁷ Pa (10 ⁻⁹ Torr)
Max continuous outlet pressure	660 Pa (5 Torr)
Max Nitrogen throughput	2500 sccm
Rated speed	48000 rpm
Starting time	4 min
Max inlet flange temperature	120 °C
Input voltage	100 to 120 (± 10) V a.c. or 200 to 240 (± 10) V a.c.
Power consumption	0.6 kVA
Pump weight	15 kg
Controller weight	9 kg

Ordering Information

Product Description	Order No.
STPH301C ISO100K Inlet	B71901010
STPH301C DN100CF Inlet	YT340Z004
STPH301CV TMS ISO100F Inlet	YT3416001
STPH301CV TMS DN100CF Inlet	YT3416005
Accessories & Spares	Order No.
SCU-800 Control unit	YT49Z2Z00
Power Cable 5m	PT49Y0A00
Power Cable 10m	PT49Y0A01
Connection Cable 3m	B75130050
STP straight connection Cable, 5m	B75130020
STP straight connection cable ,10m	B75130060
TMS Connection Cable Kit	PT330V000
TMS Connection Cable Kit	PT330V001
TMS Connection Cable Kit	PT330V002

STPH451C Turbomolecular Vacuum Pump



Edwards high performance STPH451C turbomolecular pump has been designed for use in the harshest of semiconductor applications. The pumps field proven reliability and class-leading performance give maximum process flexibility. The STPH451C has been approved for use by major equipment manufacturers in the semiconductor and magnetic media industries.

Features & Benefits

- Advanced rotor technology
- Higher gas throughput
- Maximized process flexibility
- Oil free
- Low vibration

Dimensions

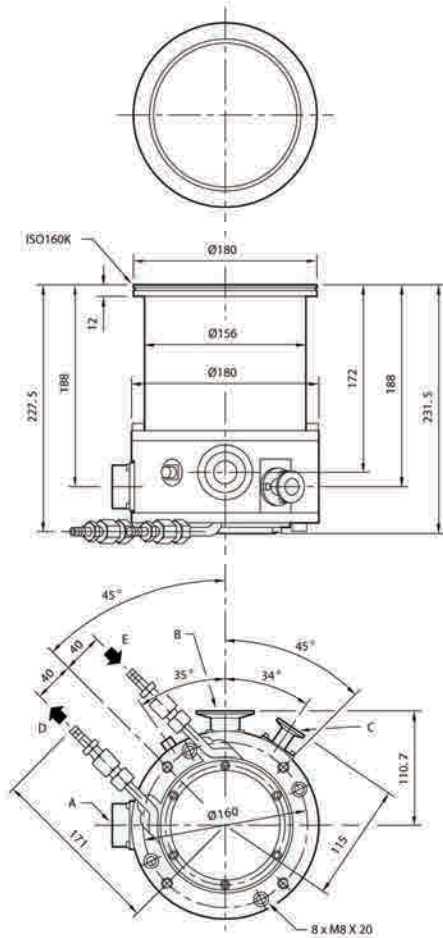

- | | | | | | |
|---|----------------------|---|------------------|---|------------|
| A | Electrical connector | B | Outlet port | C | Purge port |
| D | Cooling water out | E | Cooling water in | | |

Applications

- Plasma etch (chlorine, fluorine and bromine chemistries) for metal (aluminum), tungsten and dielectric (oxide) and polysilicon
- Electron cyclotron resonance (ECR) etch
- Film deposition CVD, PECVD, ECRCVD, MOCVD
- Sputtering
- Ion implantation source, beam line pumping end station

Performance Curves

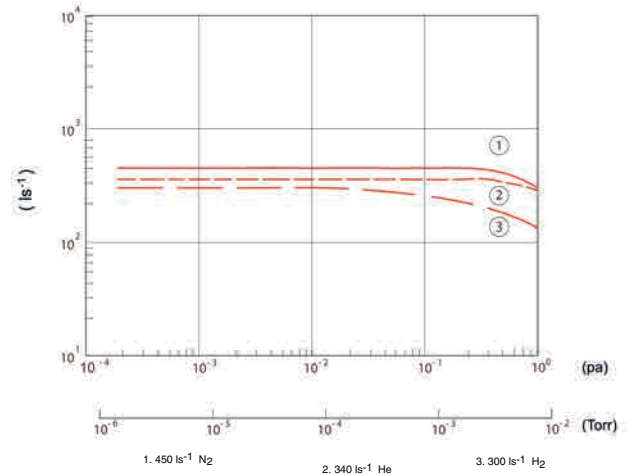

Technical Data

Inlet flange	ISO160K
Outlet port	KF40
Purge port	KF10
Water cooling fitting	PT1/4
Pumping Speed	
N ₂	450 ls ⁻¹
H ₂	300 ls ⁻¹
Compression ratio	
N ₂	>10 ⁸
H ₂	10 ³
Ultimate pressure with bake out heating	10 ⁻⁷ Pa (10 ⁻⁹ Torr)
Max continuous outlet pressure	660 Pa (5 Torr)
Max Nitrogen throughput	2500 sccm
Rated speed	48000 rpm
Starting time	4 min
Max inlet flange temperature	120 °C
Input voltage	100 to 120 (± 10) V a.c. or 200 to 240 (± 10) V a.c.
Power consumption	0.6 kVA
Pump weight	15 kg
Controller weight	9 kg

Ordering Information

Product Description	Order No.
STPH451C ISO160K Inlet	B71901001
STPH451C DN160CF Inlet	PT340Z005
STPH451CV TMS ISO160F Inlet	YT3416007
STPH451CV TMS DN160CF Inlet	YT3416006
Accessories & Spares	Order No.
SCU-800 Control unit	YT49Z2Z00
Power Cable 5m	PT49Y0A00
Power Cable 10m	PT49Y0A01
Connection Cable 3m	B75130050
STP straight connection Cable, 5m	B75130020
STP straight connection cable ,10m	B75130060
TMS Connection Cable Kit	PT330V000
TMS Connection Cable Kit	PT330V001
TMS Connection Cable Kit	PT330V002

STPA803C Turbomolecular Vacuum Pump



Edwards STPA803C turbomolecular pump is designed for use in semiconductor applications. Edwards advanced rotor technology gives class-leading performance for maximum process flexibility. The STPA803C has been approved for use by major equipment manufacturers in the semiconductor and magnetic media industries.

Features & Benefits

- Advanced rotor technology
- Maximized process flexibility
- Oil free
- Low vibration
- High reliability

Dimensions

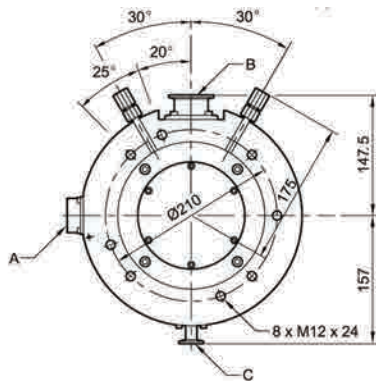
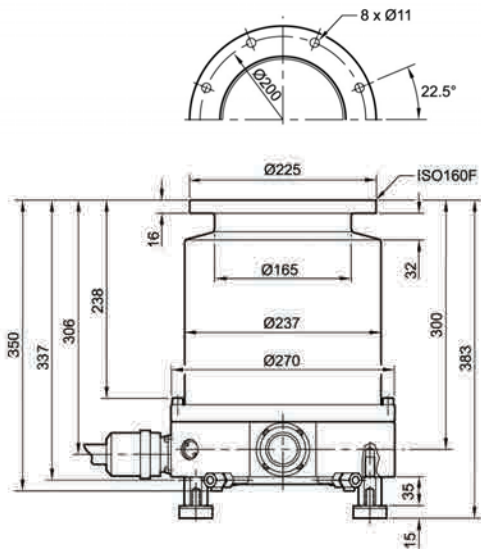

A. Electrical connector B. Outlet port C. Purge port

Applications

- Plasma etch (chlorine, fluorine and bromine chemistries) for metal (aluminum), tungsten and dielectric (oxide) and polysilicon
- Electron cyclotron resonance (ECR) etch
- Film deposition CVD, PECVD, ECRCVD, MOCVD
- Sputtering
- Ion implantation source, beam line pumping end station

Performance Curves

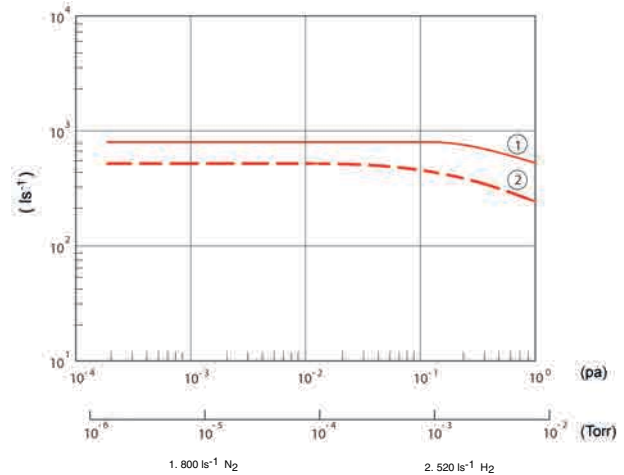

Technical Data

Inlet flange	ISO160F
Outlet port	KF40
Purge port	KF10
Water cooling fitting	PT1/4
Pumping Speed	
N ₂	800 ls ⁻¹
H ₂	520 ls ⁻¹
Compression ratio	
N ₂	>10 ⁸
H ₂	10 ³
Ultimate pressure with bake out heating	10 ⁻⁷ Pa (10 ⁻⁹ Torr)
Max continuous outlet pressure	270 Pa (2 Torr)
Max Nitrogen throughput	1500 sccm
Rated speed	32500 rpm
Starting time	7 min
Max inlet flange temperature	120 °C
Input voltage	200 to 240 (± 10) V a.c.
Power consumption	0.85 kVA
Pump weight	39 kg
Controller weight	9 kg

Ordering Information

Product Description	Order No.
STPA803C ISO160F Inlet	YT36B0040
STPA803C DN160CF Inlet	YT36B0010
STPA803CV (TMS) ISO160F Inlet	YT3626000
STPA803CV (TMS) DN160CF Inlet	YT3626003
Accessories & Spares	Order No.
SCU-800 Control unit	YT49Z2Z00
Power Cable 5m	PT49Y0A00
Power Cable 10m	PT49Y0A01
STP straight connection Cable, 5m	B75130020
STP straight connection cable ,10m	B75130060
TMS Connection Cable Kit	PT330V000
TMS Connection Cable Kit	PT330V001
TMS Connection Cable Kit	PT330V002

STPA1303C Turbomolecular Vacuum Pump



Edwards STPA1303C is a turbomolecular pump designed for use in semiconductor applications. Edwards advanced rotor technology gives class-leading performance for maximum process flexibility. The STPA1303C has been approved for use by major equipment manufacturers in the semiconductor and magnetic media industries.

Features & Benefits

- Advanced rotor technology
- Higher gas throughput
- Maximized process flexibility
- Oil free
- Low vibration

Dimensions

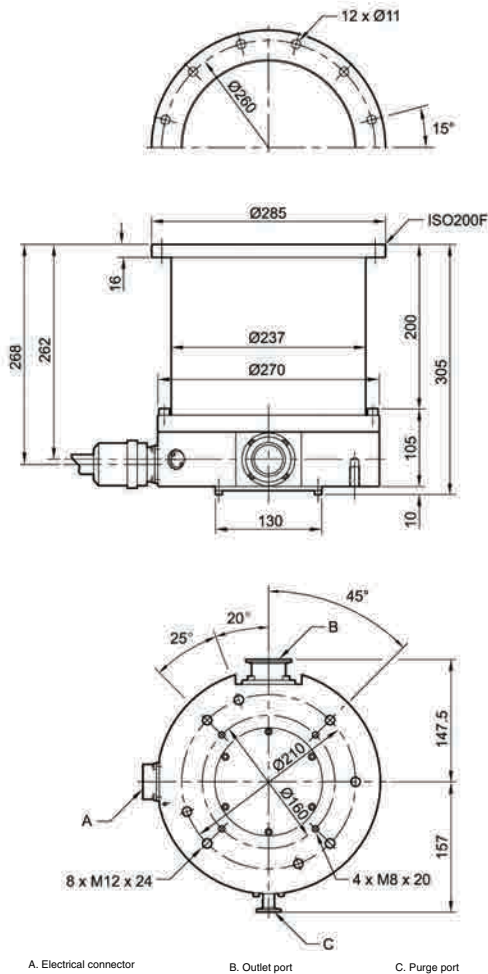

Applications

- Plasma etch (chlorine, fluorine and bromine chemistries) for metal (aluminum), tungsten and dielectric (oxide) and polysilicon
- Electron cyclotron resonance (ECR) etch
- Film deposition CVD, PECVD, ECRCVD, MOCVD
- Sputtering
- Ion implantation source, beam line pumping end station

Performance Curves

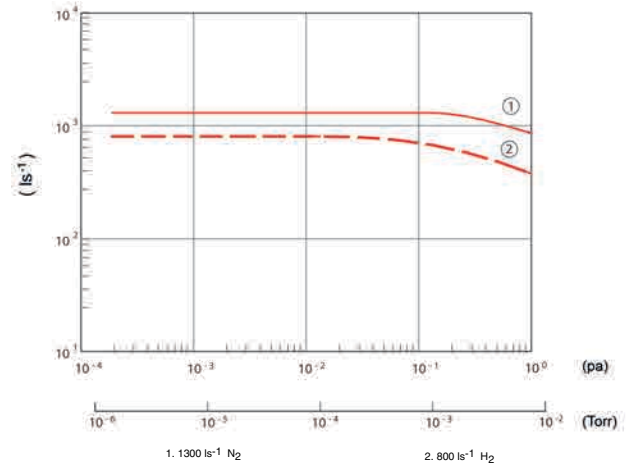

Technical Data

Inlet flange	ISO200F
Outlet port	KF40
Purge port	KF10
Water cooling fitting	PT1/4
Pumping Speed	
N ₂	1300 ls ⁻¹
H ₂	800 ls ⁻¹
Compression ratio	
N ₂	>10 ⁸
H ₂	10 ³
Ultimate pressure with bake out heating	10 ⁻⁷ Pa (10 ⁻⁹ Torr)
Maximum continuous outlet pressure *	270 Pa (2 Torr)
Maximum Nitrogen throughput *	1500 sccm
Rated speed	32500 rpm
Starting time	7 min
Maximum inlet flange temperature	120 °C
Input voltage	200 to 240 (± 10) V a.c.
Power consumption	0.85 kVA
Pump weight	39 kg
Controller weight	9 kg

* Water cooled

Ordering Information

Product Description	Order No.
STPA1303C ISO200F Inlet	B71802020
STPA1303C DN200CF Inlet	YT36B0030
STPA1303C TMS ISO200F Inlet	YT3626005
STPA1303C TMS DN200CF Inlet	YT3626004
Accessories & Spares	Order No.
SCU-800 Control unit	YT49Z2Z00
Power Cable 5m	PT49Y0A00
Power Cable 10m	PT49Y0A01
Connection Cable 3m	B75130050
STP straight connection Cable, 5m	B75130020
STP straight connection cable ,10m	B75130060
TMS Connection Cable Kit	PT330V000
TMS Connection Cable Kit	PT330V001
TMS Connection Cable Kit	PT330V002

STPA1603C Turbomolecular Vacuum Pump



The small and powerful Edwards STPA1603C turbo-molecular pump has been designed using Edwards advanced rotor technology. This provides high throughput, maximum reliability and class leading performance which is demanded by the latest generation of semiconductor processes. Its half rack controller and compact design provide considerable space saving, whilst its advanced deposition reduction system gives improved reliability and performance. The STPA1603C has been qualified on the latest 200 mm etch tools as well as on new generation 300 mm oxide etch processes.

Features & Benefits

- Advanced rotor design
- Increased performance
- Higher gas throughput
- High reliability
- Maintenance free

Dimensions

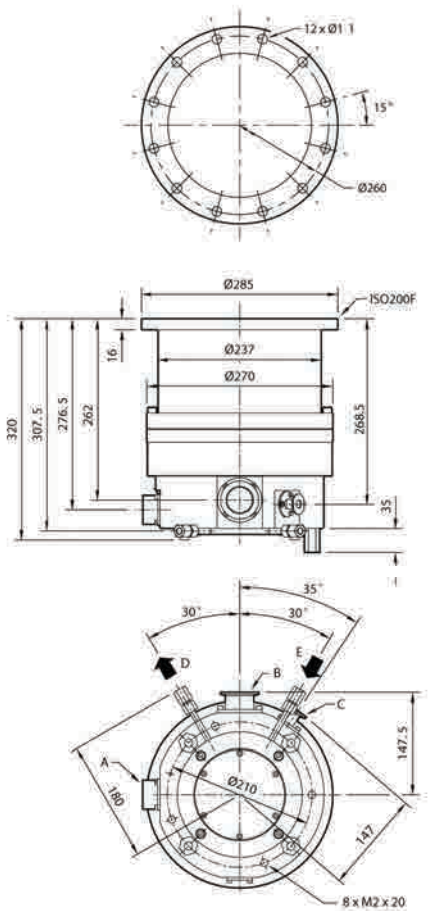

- | | | | | | |
|---|----------------------|---|------------------|---|------------|
| A | Electrical connector | B | Outlet port | C | Purge port |
| D | Cooling water out | E | Cooling water in | | |

Applications

- Plasma etch (chlorine, fluorine and bromine chemistries) for metal (aluminum), tungsten and dielectric (oxide) and polysilicon
- Electron cyclotron resonance (ECR) etch
- Film deposition CVD, PECVD, ECRCVD, MOCVD
- Sputtering
- Ion implantation source, beam line pumping end station

Performance Curves

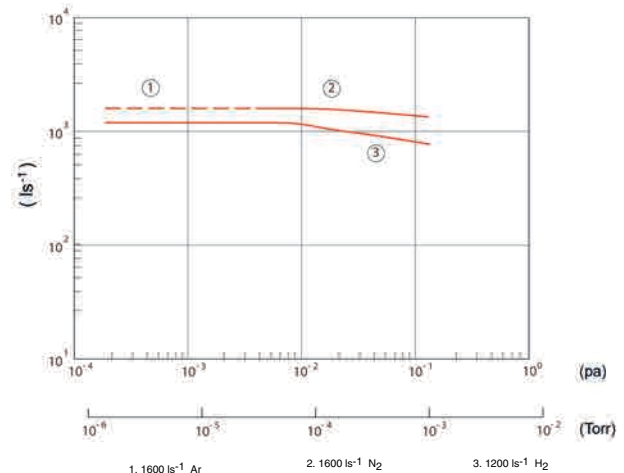

Technical Data

Inlet flange	ISO200F
Outlet port	KF40
Purge port	KF16
Water cooling fitting	PT1/4
Pumping Speed	
N ₂	1600 ls ⁻¹
H ₂	1200 ls ⁻¹
Compression ratio	
N ₂	>10 ⁸
H ₂	>7 x 10 ³
Ultimate pressure with bake out heating	10 ⁻⁷ Pa
Max allowable backing pressure	266 Pa (2 Torr)
Max Nitrogen throughput	2500 sccm
Rated speed	36500 rpm
Starting time	7 min
Mounting position	Any
Water cooling flow	2 lmin ⁻¹
Temperature	5-25 °C
Pressure	0.3 MPa
Recommended purge gas flow	20 sccm
Input voltage	200 to 240 (± 10) V a.c.
Power consumption	0.85 kVA
Pump weight	35 kg
Controller weight	9 kg

Ordering Information

Product Description	Order No.
STPA1603C ISO200F Inlet	B75100010
STPA1603C DN200CF Inlet	B75100100
STPA1603CV TMS ISO200F Inlet	YT4616004
STPA1603CV TMS DN200CF Inlet	YT4616005
Accessories & Spares	Order No.
SCU-800 Control unit	YT49Z2Z00
Power Cable 5m	PT49Y0A00
Power Cable 10m	PT49Y0A01
STP straight connection Cable, 5m	B75130020
STP straight connection cable ,10m	B75130060

STPA2203C Turbomolecular Vacuum Pump



Edwards STPA2203C is a new turbomolecular pump designed for use in semiconductor applications. It has advanced rotor technology that gives class-leading performance for maximum process flexibility. A new half rack controller gives additional space savings and incorporates d.c. drive technology for battery-free operation. The STPA2203C has been approved for use by major etch, ion implant and deposition equipment manufacturers in the semiconductor and magnetic media industries.

Features & Benefits

- Advanced rotor design
- Higher gas throughput
- Maximized process flexibility
- 5 Axis Magnetic Suspension System
- Zero contamination

Dimensions

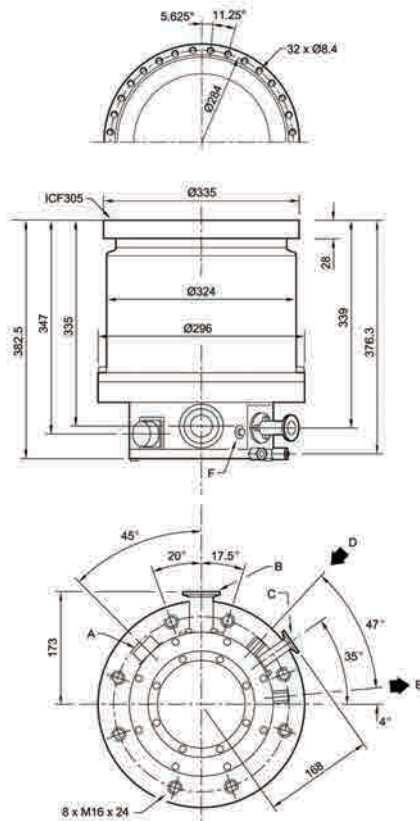

- | | | | | | |
|---|----------------------|---|------------------|---|------------------------------|
| A | Electrical connector | B | Outlet port | C | Purge port |
| D | Cooling water out | E | Cooling water in | F | Temperature sensor connector |

Applications

- Plasma etch (chlorine, fluorine and bromine chemistries) for metal (aluminum), tungsten and dielectric (oxide) and polysilicon
- Electron cyclotron resonance (ECR) etch
- Film deposition CVD, PECVD, ECRCVD, MOCVD
- Sputtering
- Ion implantation source, beam line pumping end station

Performance Curves

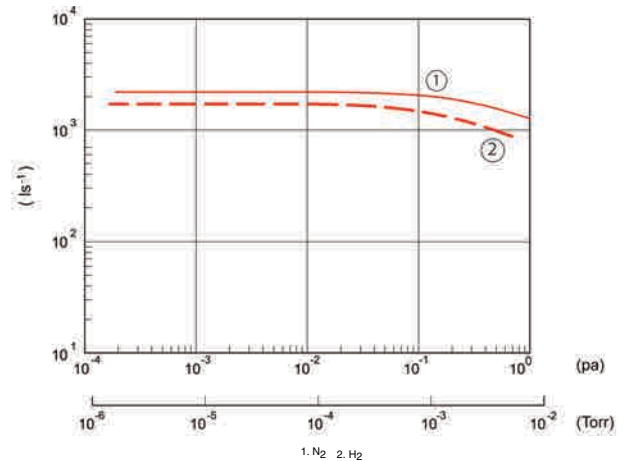

Technical Data

Inlet flange	ISO250F
Outlet port	KF40
Purge port	KF10
Water cooling fitting	PT1/4
Pumping Speed	
N ₂	2200 ls ⁻¹
H ₂	1700 ls ⁻¹
Compression ratio	
N ₂	>10 ⁸
H ₂	>2.5 x 10 ⁴
Ultimate pressure	10 ⁻⁶ Pa (10 ⁻⁸ Torr)
Maximum allowable backing pressure	400 Pa (3 Torr)
Maximum Nitrogen throughput	1500 sccm
Rated speed	27000 rpm
Starting time	7 min
Mounting position	Any
Water cooling flow	2 lmin ⁻¹
Water cooling temperature	5-25 °C
Pressure	0.3 MPa
Recommended purge gas flow	20 sccm
Input voltage	200 to 240 (± 10) V a.c.
Power consumption	1.5 kVA
Pump weight	61 kg
Controller weight	12 kg

Ordering Information

Product Description	Order No.
STPA2203C ISO250F Inlet	YT4V0Z002
STPA2203C DN250CF Inlet	YT4V0Z003
STPA2203CV TMS ISO250F Inlet	YT4V66001
STPA2203CV TMS DN250CF Inlet	YT4V66002
Accessories & Spares	Order No.
SCU-1600 Control unit	YT76Z0Z00
Power Cable 5m	B75030020
Power Cable 10M	PT35Y0A00
STP straight connection cable, 5m	B75030010
STP straight connection cable, 10m	B75030040
5m TMS connection cable kit	PT351V000
10m TMS connection cable kit	PT351V001
15m TMS connection cable kit	PT351V002

STP-XA2703C Turbomolecular Pump



The STP-XA2703C turbo pump offers high performance in the process range of high vacuum to 2300 sccm process flow with enhanced throughput for all gases.

This pump is based on a new platform design offering features to improve thermal management, which enhances performance on harsh processes, increases the maximum process flow capability and reduces the effects of corrosion and deposition.

The outstanding performance is suited to both light and harsh applications, such as semiconductor etch, implant, lithography and LCD processes.

Features & Benefits

- Advanced rotor design
- Increased H₂, N₂ and Ar performance
- Improved performance in the process pressure range of high vacuum to 2300 sccm
- Maintenance free
- 5-axis magnetic suspension system

Dimensions

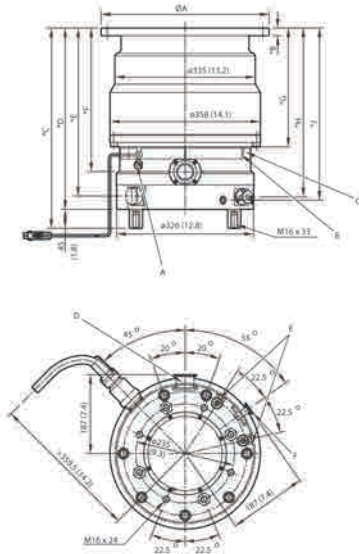

	VG250	ISO250F	ICF305 (DN250CF)
A	350 (13.8)	335 (13.2)	305 (12.0)
*B	15 (0.6)	15 (0.6)	28 (1.1)
*C	454 (17.9)	454 (17.9)	459 (18.1)
*D	409 (16.1)	409 (16.1)	414 (16.3)
*E	377.5 (14.9)	377.5 (14.9)	383 (15.1)
*F	319 (12.6)	319 (12.6)	325 (12.8)
*G	262 (10.3)	262 (10.3)	267 (10.5)
*H	379.5 (14.9)	379.5 (14.9)	385 (15.2)
*J	387 (15.2)	387 (15.2)	393 (15.5)

mm (inch)

- A Temperature management system (TMS) sensor
- B TMS Heater (TMS spec only)
- C TMS heater cover (TMS spec only)
- D Outlet port KF40
- E Cooling water port Rc 1/4 ISO
- F Purge port KF10

Applications

- Plasma etch (chlorine, fluorine and bromine chemistries) for metal (aluminum), tungsten and dielectric (oxide) and polysilicon
- Electron cyclotron resonance (ECR) etch
- Film deposition CVD, PECVD, ECRCVD, MOCVD
- Sputtering
- Ion implantation source, beam line pumping end station

Performance Curves

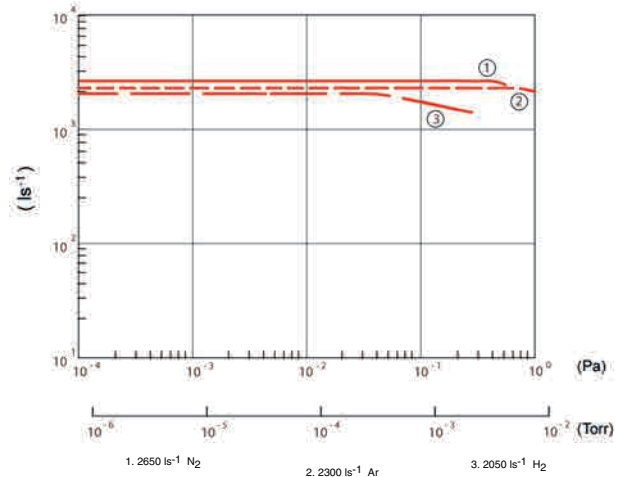

Technical Data

Inlet flange	VG250
Pumping Speed	
N ₂	2650 ls ⁻¹
H ₂	2050 ls ⁻¹
Compression ratio	
N ₂	>10 ⁸
H ₂	>6 x 10 ³
Ultimate pressure	10 ⁻⁷ Pa
Max allowable backing pressure	266 Pa
Max allowable gas flow	
N ₂ (water cooled)	2300 sccm (3.8 Pam ³ s ⁻¹)
Ar (water cooled)	1900 sccm (3.2 Pam ³ s ⁻¹)
Rated speed	27500 rpm
Starting time	8 min
Mounting position	Any orientation
Water cooling Flow	3 lmin ⁻¹
Water cooling Temperature	5-25 °C (41-77 °F)
Pressure	0.3 MPa
Recommended purge gas flow	50 sccm (8.4 x 10 ⁻² Pam ³ s ⁻¹)
Input voltage	200 to 240 V a.c. (± 10)
Power consumption	1.5 kVA
Pump weight	75 kg (165 lb)
Controller weight	12 kg (26.4 lb)

Ordering Information

Product Description	Order No.
STP-XA2703C VG250	YT660Z110
STP-XA2703C ISO250	PT660Z140
STP-XA2703C DN250CF	YT6610010
Accessories & Spares	Order No.
SCU-1600 Control unit	YT76Z0Z00
Power Cable 5m	B75030020
Power Cable 10M	PT35Y0A00
STP straight connection cable, 5m	B75030010
STP straight connection cable, 10m	B75030040

STP-XA3203C Turbomolecular Pump



The STP-XA3203C turbo pump offers high performance in the process range of high vacuum to 2300 sccm process flow with enhanced throughput for all gases.

This pump is based on a new platform design offering features to improve thermal management, which enhances performance on harsh processes, increases the maximum process flow capability and reduces the effects of corrosion and deposition.

The outstanding performance is suited to both light and harsh applications, such as semiconductor etch, implant, lithography and LCD processes.

Features & Benefits

- Advanced rotor design
- Increased H₂, N₂ and Ar performance
- Improved performance in the process pressure range of high vacuum to 2300 sccm
- Maintenance free
- 5-axis magnetic suspension system

Dimensions

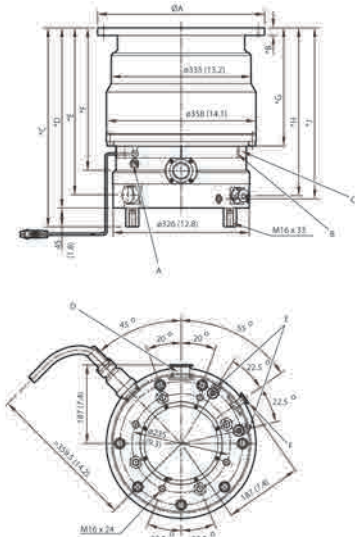

	VG300	ISO320F	ICF356 (DN320CF)
A	400 (15.8)	425 (16.7)	356 (14.0)
*B	18 (0.7)	20 (0.8)	28.5 (1.1)
*C	415.5 (16.4)	415.5 (16.4)	454.5 (17.9)
*D	370.5 (14.6)	370.5 (14.6)	409.5 (16.1)
*E	339 (13.3)	339 (13.3)	378.5 (14.9)
*F	280.5 (11.0)	280.5 (11.0)	320.5 (12.6)
*G	223.5 (8.8)	223.5 (8.8)	262.5 (10.3)
*H	341 (13.4)	341 (13.4)	380.5 (15.0)
*J	348.5 (13.7)	348.5 (13.7)	388 (15.3)

mm (inch)

- A Temperature management system (TMS) sensor
- B TMS Heater (TMS spec only)
- C TMS heater cover (TMS spec only)
- D Outlet port KF40
- E Cooling water port 1/4 ISO
- F Purge port KF10

Applications

- Plasma etch (chlorine, fluorine and bromine chemistries) for metal (aluminum), tungsten and dielectric (oxide) and polysilicon
- Electron cyclotron resonance (ECR) etch
- Film deposition CVD, PECVD, ECRCVD, MOCVD
- Sputtering
- Ion implantation source, beam line pumping end station

Performance Curves

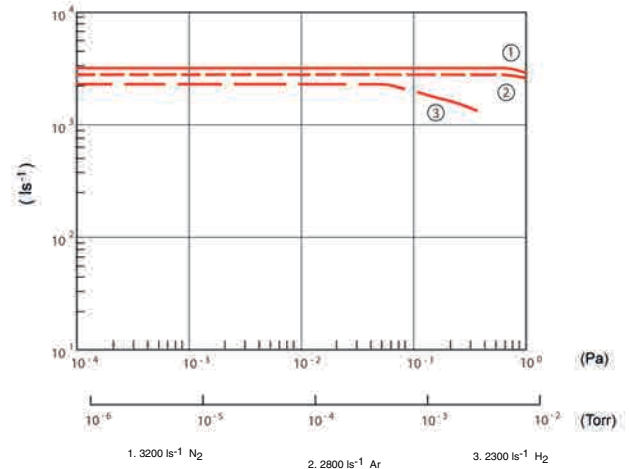

Technical Data

Inlet flange	ISO320F
Pumping Speed	
N ₂	3200 ls ⁻¹
H ₂	2300 ls ⁻¹
Compression ratio	
N ₂	>10 ⁸
H ₂	>6 x 10 ³
Ultimate pressure	10 ⁻⁷ Pa
Max allowable backing pressure	266 Pa
Max allowable gas flow	
N ₂ (water cooled)	2300 sccm (3.8 Pam ³ s ⁻¹)
Ar (water cooled)	1900 sccm (3.2 Pam ³ s ⁻¹)
Rated speed	27500 rpm
Starting time	8 min
Mounting position	Any orientation
Water cooling	
Flow	3 lmin ⁻¹
Temperature	5-25 °C (41-77 °F)
Pressure	0.3 MPa
Recommended purge gas flow	50 sccm (8.4 x 10 ⁻² Pam ³ s ⁻¹)
Input voltage	200 to 240 (± 10) V a.c.
Power consumption	1.5 kVA
Pump weight	80 kg (176 lb)
Controller weight	12 kg (26.4 lb)

Ordering Information

Product Description	Order No.
STP-XA3203C ISO320F	YT660Z050
STP-XA3203C DN320CF	PT660Z080
STP-XA3203C VG300	YT660Z150
Accessories & Spares	Order No.
SCU-1600 Control unit	YT76Z0Z00
Power Cable 5m	B75030020
Power Cable 10M	PT35Y0A00
STP straight connection cable, 5m	B75030010
STP straight connection cable, 10m	B75030040

STP-XA4503C Turbomolecular Pump



The STP-XA4503C magnetic bearing turbomolecular pump has a wide process window, from high vacuum, to high flow requirements with enhanced throughput for all gases.

This pump is based on a new design, offering features to improve thermal management, which enhances performance on harsh processes, increases the maximum process flow capability and reduces the effects of corrosion and deposition.

It has been designed to handle light and harsh duty applications, such as etch, implant, lithography and FPD processes.

Features & Benefits

- Advanced Rotor Design
- Increased Argon performance
- Highest pumping speed in its class
- Wide process window
- Higher throughput at lower pressure

Ordering Information

Product Description	Order No.
STP-XA4503C ISO320F Inlet	YT670Z040
Accessories & Spares	Order No.
Power Cable 10M	PT35Y0A00
Power Cable 5m	B75030020
SCU-1600 Control unit	YT76Z0Z00
STP straight connection cable, 10m	B75030040
STP straight connection cable, 5m	B75030010

Dimensions

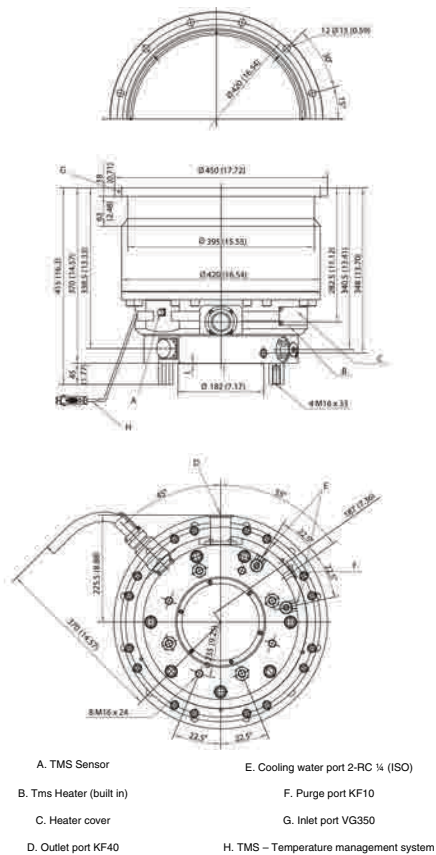

Performance Curves

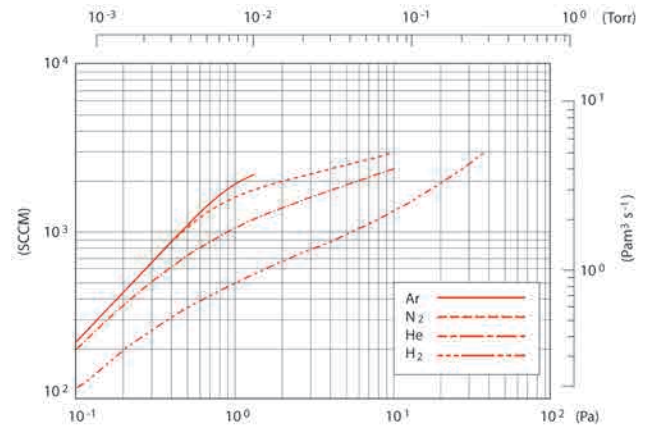

Technical Data

Inlet flange size	VF300, ISO320F, VG350
Backing port size	KF40
Pumping speed	
N ₂	3800 to 4300 ls ⁻¹ (dependant on model)
H ₂	2500 ls ⁻¹
Compression ratio	
N ₂	>10 ⁸
H ₂	6 x 10 ³
Ultimate pressure	10 ⁻⁷ Pa / 10 ⁻⁹ mbar
Max allowable backing pressure	266 Pa / 2.66 mbar
Max allowable gas flow N ₂ (Water cooled only)	2800 sccm
	4.73 Pam ³ s ⁻¹
Maximum allowable gas flow Ar(Water cooled only)	2150 sccm
	3.63 Pam ³ s ⁻¹
Rated speed	24000 rpm
Run up time to 90% rated speed	12 minutes
Mounting position	Any orientation
Water cooling	
Flow	3 lmin ⁻¹
Temperature	5 – 25 °C / 41 – 77 °F
Pressure	0.3 MPa
Recommended purge gas flow N ₂	50 sccm / 8.4 x 10 ⁻² Pam ³ s ⁻¹
Input voltage	200 – 240 ±10 % V a.c.
Maximum input power (without TMS)	1.5 KVA

SCU-350 Control Unit



The Edwards new SCU-350 control unit is a EU-RoHS compliant controller for small sized turbo pumps. It is fully compatible with the current control unit models, but has an improved vibration property at low frequency range. It also has lower input voltage, which contributes to a reduction in electric capacity and tool power consumption. The SCU-350 has improved noise immunity and is equipped with universal voltage function for operation with supply voltage from 100-240 VAC without switching.

Features & Benefits

- Better vibration property
- No peak vibration movement across all frequencies
- Compact design
- Smallest size control unit in its class
- Energy saving

Applications

- STP301/451 series
- STPL301/L451 series

Dimensions

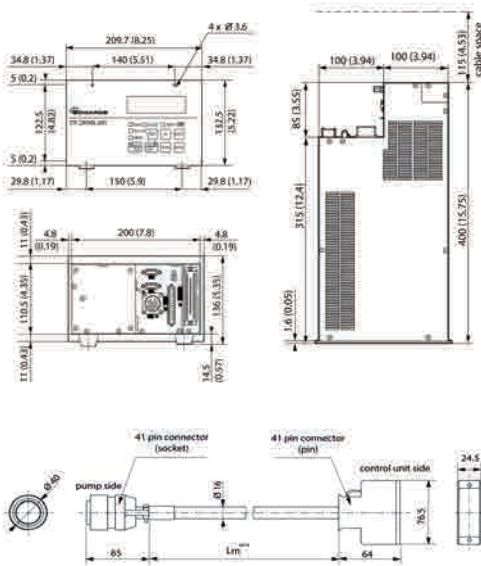

Pump to controller cable

Technical Data

Magnetic bearing control system	Digital control
Input voltage	100-120
	200-240V a.c.
Power consumption (Start up)	Max 350 VA
Power consumption (continuous)	Max 150 VA
Input frequency	50/60 ±2 Hz
Leak current	3.5 mA
Main breaker rated current	5 A
Motor drive system	3-phase DC
Allowable ambient temperature	0 to 40 °C
	(32 to 104 °F)
Weight	8 kg
Panel display	LCD

Ordering Information

Product Description	Order No.
SCU-350 Control Unit	YT21Z3ZC0
SCU-350 Turbo Pump Control Unit with RS232	YT21ZEZC0
SCU-350A Turbo Pump Control Unit with ABS	YT21ZCZC0
Accessories & Spares	Order No.
Type B P/Cab 3M Ring Terminals	B70700090
Type B P/Cab 5M Ring Terminals	B70700040
Type B P/Cab 10M Ring Terminals	PT21Y0A00
Type B P/Cab 15M Ring Terminals	PT21Y0A01
STP straight connection cable, 3m	B70700010
STP straight connection cable, 5m	B70700000
STP straight connection cable, 10m	B70700130
STP straight connection cable, 15m	B70700070
STP straight connection cable, 20m	B70700150

SCU-800 Control unit



The Edwards SCU800 turbo pump control unit is a fully digital controller, and has perfect compatibility for middle sized pumps. New AVR (Auto vibration reduction) technology achieves a further reduction in vibration levels, and the advanced pre-maintenance call function provides advanced notice of precise maintenance time. The reliability focused design, enhanced communication function, and perfect compatibility bring significant back up units savings and contributes to a reduction in total C₀O.

Features & Benefits

- Universal Controller
- Single controller is used for middle sized pumps. No requirement for different controllers for each pump type
- Service back up stocks will be reduced
- Advanced Pre-maintenance Function
- AVR (Auto Vibration Reduction) minimizes the rotate system vibration during acceleration.

Dimensions

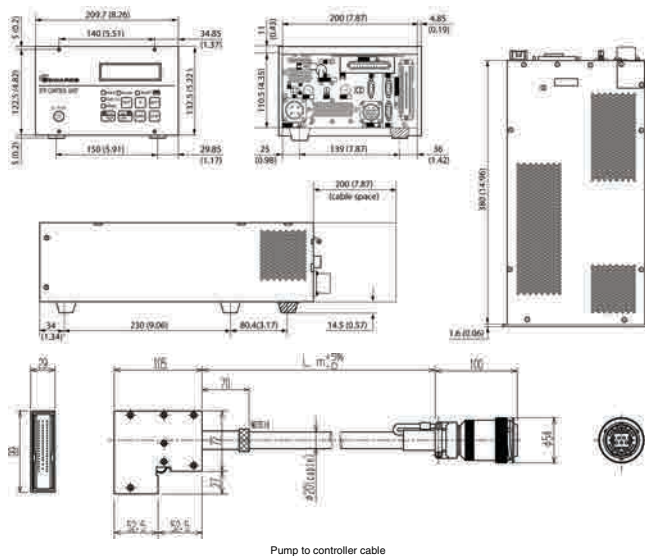

Pump to controller cable

Applications

- STP603/1003 series
- STPH301/H451 series
- STPH803/H1303 series
- STPA803C/A1303 series
- STPA1603 series

Technical Data

Magnetic bearing control system	Digital control
Input voltage	100 – 120 ±10 V a.c. 200 – 240 ±10 V a.c.
Power consumption (without Temperature Management System, TMS)	Max 850 VA
Power consumption (with TMS)	Max 1200 VA
Input frequency	50/60 ±2 Hz
Leak current	3.5 mA
Main breaker rated current	10 A
Motor drive system	3-phase d.c.
Allowable ambient temperature	0 to 40 °C (32 to 104 °F)
Weight	8.5 kg
TMS control unit	Built-in
Serial communication function (RS232/RS485)	Standard
Panel display	LCD

Ordering Information

Product Description	Order No.
SCU-800 Turbo Pump Control Unit	YT49Z2Z00
Accessories & Spares	Order No.
Power Cable 5m	PT49Y0A00
Power Cable 10m	PT49Y0A01
Power Cable 15m	PT49Y0A02
Power Cable 20m	PT49Y0A03
STP straight connection Cable, 5m	B75130020
STP straight connection cable ,10m	B75130060
STP straight connection cable, 15M	B75130070
STP straight connection cable, 20M	B75130190

SCU-1600 Control unit

The fully digital SCU-1600 turbo pump control unit is compatible with STP turbo pumps ranging from 2000 ls^{-1} to 4500 ls^{-1} . It provides reliability, enhanced communication and pump compatibility with reduced back-up unit requirements and minimized overall cost of ownership.



Features & Benefits

- Advanced pre-maintenance function
- Precise maintenance timing
- Two stage warning messages
- Rotor imbalance monitoring
- Back-up bearing damage monitoring

Dimensions

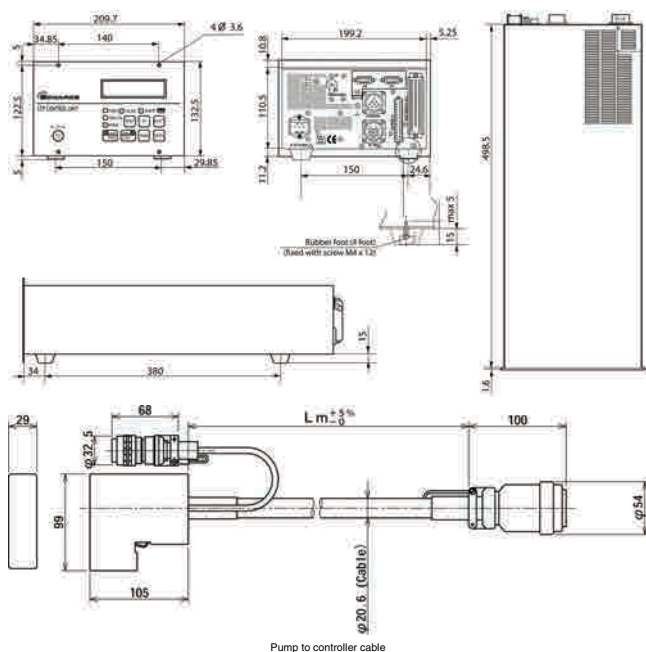

Applications

- STP-A2203/2503/2803/3003/3503
- STP-F2203
- STP-XA2703/3203/4503
- STP-XH2603/3203

Technical Data

Magnetic bearing control system	Digital control
Input voltage	200 – 240 ± 10 V a.c.
Power consumption (without Temperature Management System, TMS)	Max 1600 VA
Power consumption (with TMS)	Max 2100 VA
Input frequency	50/60 ± 2 Hz
Leak current	3.5 mA
Main breaker rated current	15 A
Motor drive system	3-phase d.c.
Allowable ambient temperature	0 to 40 °C (32 to 104 °F)
Weight	12 kg
TMS control unit	Built-in
Serial communication function (RS232/RS485)	Standard
Operation switch	Start, Stop, Reset, Select, Up, Down, Enter, Manual/Remote
Panel display	LCD

Ordering Information

Product Description	Order No.
SCU-1600 Turbo Pump Control Unit	YT76Z0Z00
Accessories & Spares	Order No.
Power cable, 15m	YT76Y0A03
Power cable, 20m	YT76Y0A04
STP straight connection cable, 5m	B75030010
STP straight connection cable, 10m	B75030040
STP straight connection cable, 15m	B75030220
STP straight connection cable, 20m	B75030230



High Throughput Diffusion Pumps	120
Vapour Booster Pumps	126
Vapour Pumps for Scientific Instruments and R&D Applications	130
Diffstak Installation	132
Vapour Pump Spares	134



HT10 high throughput vapour pump

Edwards' vapour pumps suit the widest range of applications, as we offer the most comprehensive range of pumps and accessories available from any supplier.

Our industrial, high throughput diffusion pumps and vapour booster pumps fulfil the requirements of applications like vacuum metallurgy, distillation and coating.

Our compact scientific pumps are designed for instrument and general R&D applications.

By matching the pump of your choice with appropriate accessories, we offer a complete high vacuum pumping solution for all applications.

Pumping Speed and Throughput

The pumping speed (volume flowrate) of a vapour pump is the volume of gas and vapour passing through the inlet of the pump in one second. The unit of measurement is l s^{-1} . The throughput (mass flowrate) is the mass of gas passing through the pump in one second and is measured in mbar l s^{-1} . The throughput of the pump is the same at the pump inlet and pump outlet.

At a given pressure, pumping speed (S) and throughput (Q) are related by the simple equation: $Q = P \times S$, where P is the pressure. You can use this equation to convert between pumping speed and throughput measurements.

Below about 1×10^{-3} mbar, pumping speed is the most convenient measure of the pump's performance. At these pressures, the pumping speed is proportional to the diameter of the pump inlet: a large pump is required to obtain higher pumping speeds. Above about 1×10^{-3} mbar, the pump's throughput is most often used to characterise its performance. At these pressures, the performance of the pump is affected by its internal construction as well as its overall size.

To choose the best type of vapour pump for your application, you must define the operation pressure and the pumping speed (or throughput) requirement of your application and match these to the performance characteristics of our range of vapour pumps. Remember that, when you calculate the required pumping speed, you must include provision for the process gas throughput, the outgassing of the vacuum system and the leakage into the system. You may also have to consider how quickly you want to achieve the operation pressure.

Measurement Methods

The methods used to measure pressure and flow have become more accurate in recent years allowing much tighter controls over system conditions. The speeds and throughputs quoted in the catalogue for the HT diffusion pumps are based on actual pump data derived from measurements made with the latest technology total pressure gauges and mass flow transducers in accordance with ISO standards.

Some confusion could arise with previously published speed and throughput figures for older designed pumps where, historically, pressure measurements were made with partial pressure gauges like the McLeod gauge. This older gauge can indicate speeds up to 30% higher than that expected using state of the art total pressure gauges.

Further confusion could arise from the measurement standards chosen to determine pumping performance. In the case of AVS (American Vacuum Society), this can indicate speeds and throughput up to 15% higher than ISO figures.

Historical industry practice meant that in considering the above, and potential gauge accuracy of $\pm 15\%$, it was possible to have speeds quoted 60% higher than might be expected using modern total pressure measurement equipment. This should be carefully considered when comparing specifications for older derived data published for similarly sized competitor pumps and the Edwards HT diffusion pumps.

Ultimate Vacuum

The ultimate vacuum of a vapour pump is the lowest pressure achieved in tests on the pump, measured above the inlet of the pump (or above the high vacuum valve for the Diffstaks). The ultimate vacuum depends on: the type of fluid used in the pump; the temperature of the inlet baffle; the amount of outgassing from the vacuum system; and the amount of leakage into the system.

Critical Backing Pressure

The critical backing pressure is the highest pressure that a pump can tolerate in the backing line. If the pressure is higher than the critical backing pressure, the pump may stall. The critical backing pressure depends on: the pump design; the power of the heaters; and the fluid used in the vapour pump.

Backstreaming

Backstreaming is the direct movement of molecules of pump fluid vapour from the pump toward the vacuum system. All Edwards pumps are specially designed to minimise backstreaming; the pumps have a guard ring (sometimes called a cool-cap) fitted above the top jet. The guard ring condenses vapour molecules moving from the top jet toward the vacuum system.

In some sensitive applications, backstreaming may be very undesirable; you can minimise backstreaming if you fit a baffle or a trap to the top of the pump.

Vapour Pumps for Industrial Applications

Edwards has long been a pioneer of vapour pumps and diffusion pump technology with innovations such as the diffusion pump cold cap and the combined diffusion pump, the Diffstak.

Edwards's range of high throughput diffusion pumps have many advantages in industrial applications. High throughput gives high pumping speeds at high pressures, earlier cross over from backing pump set to the diffusion pump, thus reducing pump down time to process pressure. A high tolerance to gas surges and high critical backing pressures are additional benefits of this range of pumps. The pumps, in back to back testing, are comparable to the best leading competition but also incorporating the above benefits.

To offer even higher pumping speeds, of up to $45000 \text{ m}^3\text{h}^{-1}$ at pressures intermediate between mechanical boosters and diffusion pumps Edwards can supply our industrially proven vapour booster pumps. Vapour boosters from Edwards have been proven in the field for over 30 years. A constant program of updates and improvements, with input from OEM's and end users, ensures that the vapour boosters always meet the requirements of the industry. This combined with inherent reliability, ease of use, ease of maintenance and tolerance to a wide range of inlet and exhaust pressures means they have been used extensively in metallurgy and coating industries as well as many other specialist applications.

- Vacuum metallurgy
- Distillation, drying and degassing
- Thin film coating and metallising
- Large scale research

Industrial applications require a robustly designed and constructed vapour pump often with very high throughputs. Edwards provides a complete range of vapour diffusion pumps and vapour boosters to meet these needs. All industrial diffusion pumps are water-cooled.

HT Series Pumps

These pumps are designed to give high throughput (pressure multiplied by pumping speed) at 4×10^{-3} mbar making them ideal for industrial processes that evolve large quantities of gases. Their high critical backing pressure means that they are more tolerant to sudden increases in load. They are particularly suitable for large coating systems and furnaces.

All Edwards vapour diffusion pumps are fully fractionating. This means that volatile components are fed to the lower stages of the vapour pump and the vapour fed to the inlet stage is stripped of these fractions and this improves the ultimate vacuum performance of the pump. Conduction cooled baffles above the pump help to prevent pump fluid migration into the vacuum system, which would prevent the pump achieving its ultimate vacuum. Baffles also ensure that backstreaming is minimised.

The outgassing from the system, its leak tightness, the vapour pressure of the pump fluid and the number of joints and elastomers used for seals all contribute to the pump down time and ultimate vacuum achievable. Ultimate vacuum is a function of the vapour pressure of the pump fluid selected, at a particular temperature, and in most industrial applications the pump's throughput at a particular pressure is more important than obtaining a very high ultimate vacuum. For these reasons we have elected not to quote an ultimate vacuum for our industrial vapour diffusion pumps, since it would not provide a useful measure of their performance.

By combining Edwards vapour diffusion pumps with either our GV series dry pump combinations or our oil-sealed rotary pump combinations fast pump-down and process times are achievable. Our applications specialists are able to recommend suitable pump combinations to meet specific process requirements.

Vapour Booster Pumps

Vapour booster pumps operate in a similar way to vapour diffusion pumps but generate boiler pressures approximately ten times higher than is typical for a vapour diffusion pump. The high boiler pressure feed supplies powerful ejector nozzles, that are specifically designed to increase further the throughput of the pump. The ultimate pressure of these pumps is typically in the range 10^{-4} to 10^{-5} mbar, above which the pumps exhibit considerable pumping speed for permanent gases. Additionally, they are tolerant to high backing pressures. Vapour boosters are typically used in the 10^{-1} to 10^{-4} mbar range where primary pump combinations are often at their limit and ordinary diffusion pumps exhibit instability.

Edwards booster pumps are particularly tolerant to pumping contaminated systems and processes with high gas loads of hydrogen, hence their suitability for use in metallurgical and chemical process applications.

By combining Edwards vapour booster pumps with either our GV series dry pump combinations or our oil-sealed rotary pump combinations fast pump-down and process times are achievable. Our applications specialists are able to recommend suitable pump combinations to meet specific process requirements.

HT10 Diffusion pump



The HT high throughput series is the pinnacle of our diffusion pump knowledge with technology aimed specifically at industrial users.

Edwards HT10 (ANSI10/ISO320 inlet) diffusion pump is designed for all light and heavy duty industrial applications. The robust construction gives high pumping speed at high pressure. The cast and machined aluminium interior provides consistent performance, while the stainless steel body prevents corrosion and ensures process cleanliness. These pumps are designed to give a high throughput (pressure multiplied by pumping speed) at 4×10^{-3} mbar making them ideal for industrial processes that involve large quantities of gases.

3

Page
120

Features & Benefits

- Highest throughput of comparative sized pumps
- Earliest crossover pressure of similar sized pumps
- Excellent maximum backing line pressure and tolerance to gas surges
- Comparative pumping speed to similar sized pumps
- Integral cold cap for best performance and low backstreaming

Dimensions

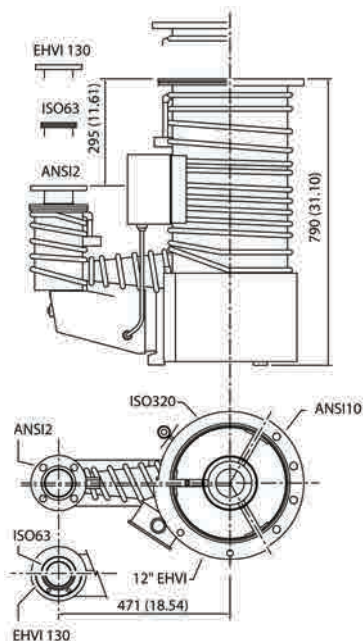

Applications

- Vacuum metallurgy
- Distillation, drying and degassing
- Thin film coating and metallizing
- Large-scale research

Performance Curves

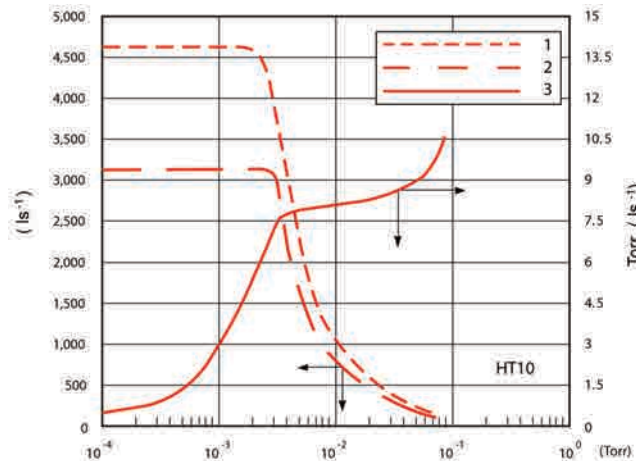
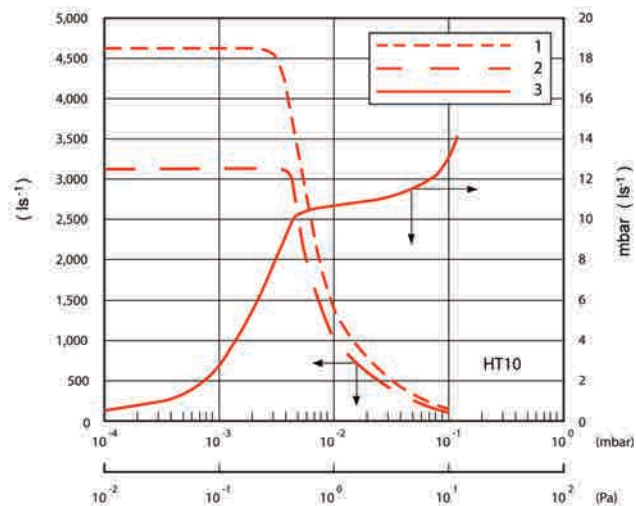

1. Comparative pumping speeds from back to back testing
2. ISO pumping speed obtained using total pressure gauges
3. ISO throughput obtained using total pressure gauges

Technical Data

Comparative pumping speed	4650 ls ⁻¹
ISO pumping speed†	
Nitrogen	3000 ls ⁻¹
Helium	4650 ls ⁻¹
AVS pumping	
Nitrogen	3330 ls ⁻¹
Helium	5165 ls ⁻¹
Maximum throughput (nitrogen)	10 mbar ls ⁻¹
	7.5 Torr ls ⁻¹
Critical backing pressure (DC704EU)	1.1 mbar
	0.8 Torr
Minimum backing pump displacement for maximum throughput	60 m ³ h ⁻¹
	35 ft ³ min ⁻¹
Recommended backing pump‡	GV80, E2M80
Recommended fluid	DC704EU
Fluid charge (dry)	1250 ml
	1.3 qt
Inlet/backing connection	ANSI10/ANSI12 or EO12 inch/EO130 mm or ISO320/ISO63
Water connection	3/8 inch NPT female
Heater power	5.1 kW
	6.8 hp
Warm up time	30 min
Minimum cooling water flow at 25°C	400 l h ⁻¹
	1.8 US gal min ⁻¹
Pressure drop across cooling water supply	1 bar
	14.5 psi
Weight	80 kg
	176 lbs

† ISO speed and throughput data obtained with total pressure measurement. Partial pressure readings typically increase data by ~30%. ISO speed measurements are typically 10% less than AVS measurements for the same pump.

‡ These are given for guidance, please contact Edwards for a recommendation of pump combinations best suited to your application.

Ordering Information

Product Description	Order No.
HT10 ANSI10/ANSI2, 200V	B31101200
HT10 ANSI10/ANSI2, 220V	B31101220
HT10 ANSI10/ANSI2, 380V	B31101380
HT10 ANSI10/ANSI2, 400V	B31101400
HT10 ANSI10/ANSI2, 415V	B31101415
HT10 ANSI10/ANSI2, 460V	B31101460
HT10 ANSI10/ANSI2, 480V	B31101480
HT10 EO12/EHV1130, 200V	B31102200
HT10 EO12/EHV1130, 220V	B31102220
HT10 EO12/EHV1130, 380V	B31102380
HT10 EO12/EHV1130, 400V	B31102400
HT10 EO12/EHV1130, 415V	B31102415
HT10 ISO320/ISO63, 200V	B31103200
HT10 ISO320/ISO63, 220V	B31103220
HT10 ISO320/ISO63, 380V	B31103380
HT10 ISO320/ISO63, 400V	B31103400
HT10 ISO320/ISO63, 415V	B31103415
HT10 ISO320/ISO63, 480V	B31103480

HT16B Diffusion pump

3

Page
122



The HT high throughput series is the pinnacle of our diffusion pump knowledge with technology aimed specifically at industrial users.

Edwards HT16B (ANSI16/ISO5000 inlet) diffusion pump is designed for all light and heavy duty industrial applications. The robust construction gives high pumping speed at high pressure. The cast and machined aluminium interior provides consistent performance, while the stainless steel body prevents corrosion and ensures process cleanliness. These pumps are designed to give a high throughput (pressure multiplied by pumping speed) at 4×10^{-3} mbar making them ideal for industrial processes that involve large quantities of gases.

Features & Benefits

- Highest throughput of comparative sized pumps
- Earliest crossover pressure of similar sized pumps
- Excellent maximum backing line pressure and tolerance to gas surges
- Comparative pumping speed to similar sized pumps
- Integral cold cap for best performance and low backstreaming

Dimensions

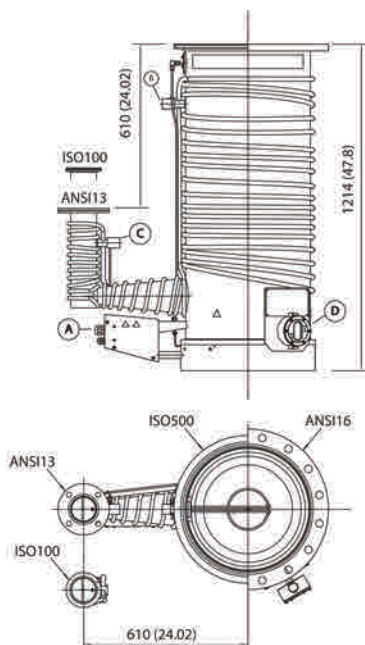

Applications

- Vacuum metallurgy
- Distillation, drying and degassing
- Thin film coating and metallizing
- Large-scale research

Performance Curves

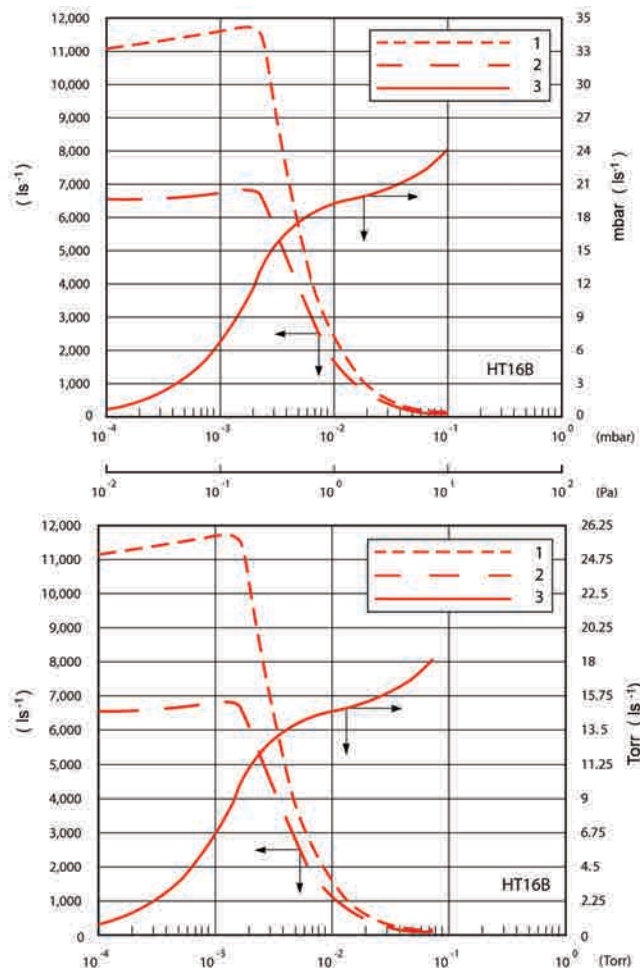

1. Comparative pumping speeds from back to back testing
 2. ISO pumping speed obtained using total pressure gauges
 3. ISO throughput obtained using total pressure gauges

Technical Data

Comparative pumping speed	11580 ls ⁻¹
ISO pumping speed†	
Nitrogen	6500 ls ⁻¹
Helium	7200 ls ⁻¹
AVS pumping	
Nitrogen	7220 ls ⁻¹
Helium	8000 ls ⁻¹
Maximum throughput (nitrogen)	18 mbar ls ⁻¹
	13.5 Torr ls ⁻¹
Critical backing pressure (DC704EU)	1.4 mbar
	1 Torr
Min backing pump displacement for max throughput	94 m ³ h ⁻¹
	55 ft ³ min ⁻¹
Recommended backing pump‡	GV80, GXS250, E2M175
Recommended fluid	DC704EU
Fluid charge (dry)	2400 ml / 2.5 qt
Inlet/backing connection	ANSI16/ANSI3 or ISO500/ISO100
Water connection	3/4 inch NPT female
Heater power	9 kW / 12 hp
Warm up time	60 min
Minimum cooling water flow at 25°C	700 l h ⁻¹ / 3.1 US gal min ⁻¹
Pressure drop across cooling water supply	1 bar / 14.5 psi
Weight	185 kg / 408 lbs

† ISO speed and throughput data obtained with total pressure measurement. Partial pressure readings typically increase data by ~30%. ISO speed measurements are typically 10% less than AVS measurements for the same pump.

‡ These are given for guidance, please contact Edwards for a recommendation of pump combinations best suited to your application.

Ordering Information

Product Description	Order No.
HT16B ANSI16/ANSI3, 200V	B31220200
HT16B ANSI16/ANSI3, 220V	B31220220
HT16B ANSI16/ANSI3, 380V	B31220380
HT16B ANSI16/ANSI3, 400V	B31220400
HT16B ANSI16/ANSI3, 415V	B31220415
HT16B ANSI16/ANSI3, 440V	B31220440
HT16B ANSI16/ANSI3, 460V	B31220460
HT16B ANSI16/ANSI3, 480V	B31220480
HT16B ISO500/ISO100, 200V	B31222200
HT16B ISO500/ISO100, 220V	B31222220
HT16B ISO500/ISO100, 380V	B31222380
HT16B ISO500/ISO100, 400V	B31222400
HT16B ISO500/ISO100, 415V	B31222415
HT16B ISO500/ISO100, 440V	B31222440
HT16B ISO500/ISO100, 460V	B31222460
HT16B ISO500/ISO100, 480V	B31222480

HT20B Diffusion pump

3

Page
124



The HT high throughput series is the pinnacle of our diffusion pump knowledge with technology aimed specifically at industrial users.

Edwards HT20B (ANSI20/ISO630 inlet) diffusion pump is designed for all light and heavy duty industrial applications. The robust construction gives high pumping speed at high pressure. The cast and machined aluminium interior provides consistent performance, while the stainless steel body prevents corrosion and ensures process cleanliness. These pumps are designed to give a high throughput (pressure multiplied by pumping speed) at 4×10^{-3} mbar making them ideal for industrial processes that involve large quantities of gases.

Features & Benefits

- Highest throughput of comparative sized pumps
- Earliest crossover pressure of similar sized pumps
- Excellent maximum backing line pressure and tolerance to gas surges
- Comparative pumping speed to similar sized pumps
- Integral cold cap for best performance and low backstreaming

Dimensions

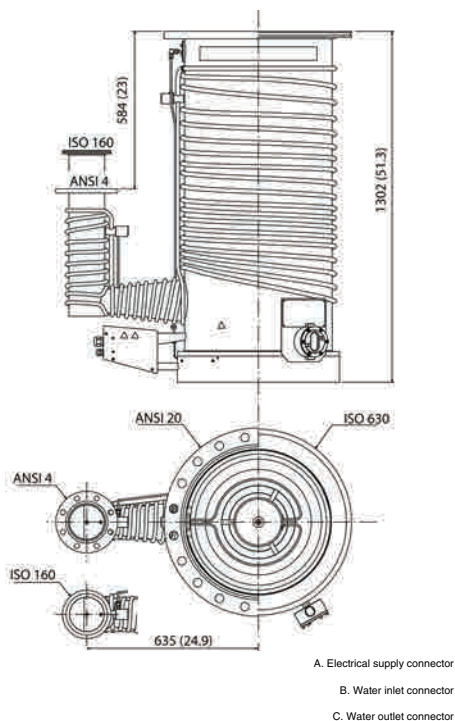

Applications

- Vacuum metallurgy
- Distillation, drying and degassing
- Thin film coating and metallizing
- Large-scale research

Performance Curves

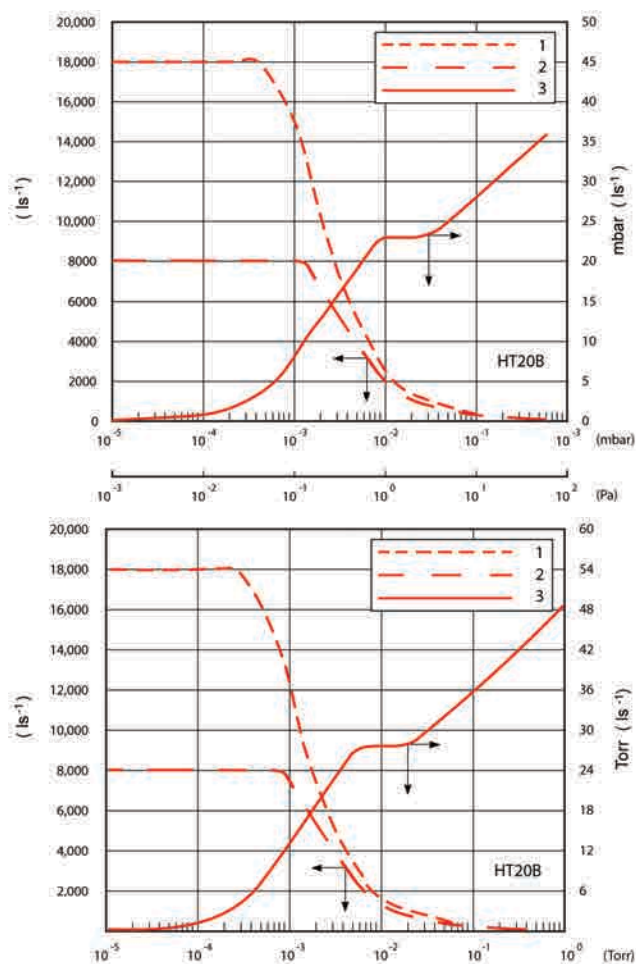

1. Comparative pumping speeds from back to back testing
2. ISO pumping speed obtained using total pressure gauges
3. ISO throughput obtained using total pressure gauges

Technical Data

Comparative pumping speed	18000 ls ⁻¹
ISO pumping speed†	
Nitrogen	8000 ls ⁻¹
Helium	16000 ls ⁻¹
Max throughput (nitrogen)	24 mbar ls ⁻¹
	18 Torr ls ⁻¹
Critical backing pressure (DC704EU)	1.3 mbar /
	1 Torr
Min backing pump displacement for max throughput	135 m ³ h ⁻¹
	80 ft ³ min ⁻¹
Recommended backing pump‡	GXS250, E2M175
Recommended fluid	DC704EU
Fluid charge (dry)	3600 ml / 3.8 qt
Inlet/backing connection	ANSI20/ANSI4 or ISO630/ISO160
Water connection	3/4 inch NPT female
Heater power	12.6 kW / 16.9 hp
Warm up time	60 min
Minimum cooling water flow at 25°C	960 l h ⁻¹ / 4.2 US gal min ⁻¹
Pressure drop across cooling water supply	1.2 bar / 17.4 psi
Weight	275 kg / 605 lbs

† ISO speed and throughput data obtained with total pressure measurement. Partial pressure readings typically increase data by ~30%. ISO speed measurements are typically 10% less than AVS measurements for the same pump.

‡ These are given for guidance, please contact Edwards for a recommendation of pump combinations best suited to your application.

Ordering Information

Product Description	Order No.
HT20B ANSI20/ANSI4, 200V	B31420200
HT20B ANSI20/ANSI4, 220V	B31420220
HT20B ANSI20/ANSI4, 380V	B31420380
HT20B ANSI20/ANSI4, 400V	B31420400
HT20B ANSI20/ANSI4, 415V	B31420415
HT20B ANSI20/ANSI4, 440V	B31420440
HT20B ANSI20/ANSI4, 460V	B31420460
HT20B ANSI20/ANSI4, 480V	B31420480
HT20B ISO630/ISO160, 200V	B31422200
HT20B ISO630/ISO160, 220V	B31422220
HT20B ISO630/ISO160, 380V	B31422380
HT20B ISO630/ISO160, 400V	B31422400
HT20B ISO630/ISO160, 415V	B31422415
HT20B ISO630/ISO160, 440V	B31422440
HT20B ISO630/ISO160, 460V	B31422460
HT20B ISO630/ISO160, 480V	B31422480

18B4B Vapour Booster Pump



The Edwards 18B4B vapour booster pumps offer higher pumping speeds, of up to 6000 l s⁻¹ at pressures intermediate between mechanical boosters and diffusion pumps. Vapour boosters from Edwards have been proven in the field for over 30 years. With a constant program of updates and modernisation, with input from OEM's and end users, combined with inherent reliability, ease of use and tolerance to various inlet and exhaust pressures they have been used extensively in metallurgy and coating industries as well as other specialist applications.

3

Page
126

Features & Benefits

- Very large pumping speed at high operating pressures
- Very high throughput at operating pressures
- Quick crossover for excellent pump down times
- Industry proven for over 40 years
- Excellent reliability

Dimensions

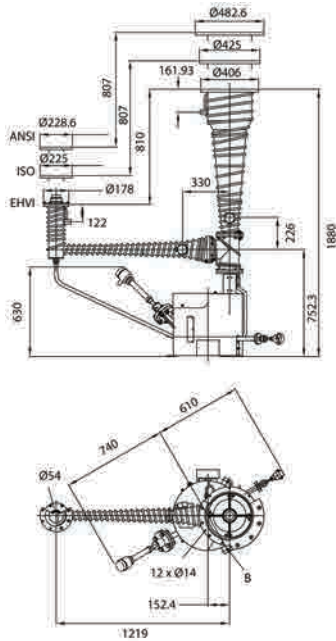

B. Position of base securing holes 3 x 7/16 inch (12.7mm) diameter on 21 5/8 inch (549mm) p.c.d.

Applications

- Vacuum metallurgy
- Distillation, drying and degassing
- Thin film coating and metallizing
- Large-scale research

Performance Curves

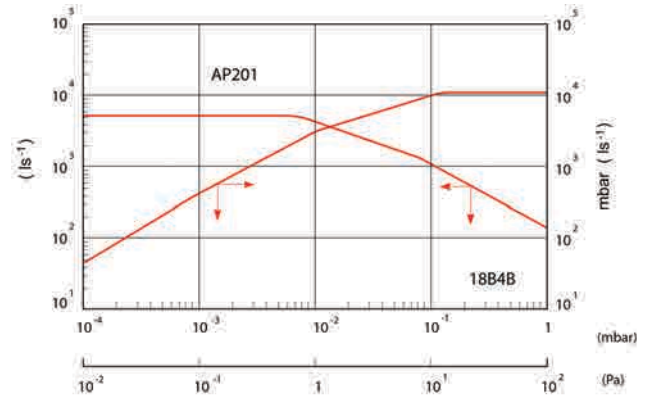

Technical Data

Pumping speed	
air	4000 ls ⁻¹
hydrogen	6000 ls ⁻¹
Maximum throughput	100 mbar ls ⁻¹ / 75 Torr ls ⁻¹
Critical backing pressure (with AP201 fluid)	2-2.6 mbar / 1.5-2 Torr
Recommended backing pump displacement	190 m ³ h ⁻¹ / 112 ft ³ min ⁻¹
Recommended backing pump	GXS450, E2M275
Recommended fluid	Apiezon® AP201
Fluid charge	10 litre / 9.5 qt
Inlet connection	8x11mm holes on 387.4 PCD (Edwards) / ANSI 12 inch / ISO320
Backing connection	2 inch union (Edwards) / ANSI 4 inch / ISO160
Water connection	-
Heater power	6.0 kW / 8 hp
Warming up time for full performance at maximum heater input	60 min
Minimum water flow inlet	375 l h ⁻¹ @ 20°C / 1.8 US gal min ⁻¹ @ 20°C
Water block threaded hole	½ inch BSP
Weight	165 kg / 365 lbs

Ordering Information

18B4B	Flanges
	1 Edwards (same as previous models 18B4A)
	2 ANSI
	3 ISO
	Oil monitoring
	0 None
	1 Temperature only
	2 Level only
	3 Both temperature and level
B	0 6 - 5 - - - -
	↑ ↑ ↑
	Voltage
	200-210 Volts 200
	220-230 Volts 220
	240-250 Volts 240
	380-440 Volts 380
	415-440 Volts 440
	460-480 Volts 480

30B5M Vapour Booster Pump



The Edwards 30B5M vapour booster pumps offer higher pumping speeds, of up to 15000 ls^{-1} at pressures intermediate between mechanical boosters and diffusion pumps. Vapour boosters from Edwards have been proven in the field for over 30 years. With a constant program of updates and modernisation, with input from OEM's and end users, combined with inherent reliability, ease of use and tolerance to various inlet and exhaust pressures they have been used extensively in metallurgy and coating industries as well as other specialist applications.

Features & Benefits

- Very large pumping speed at high operating pressures
- Very high throughput at operating pressures
- Quick crossover for excellent pumpdown times
- Industry proven for over 40 years and continuously updated to suit OEM and end-user requirements
- Excellent reliability

Dimensions

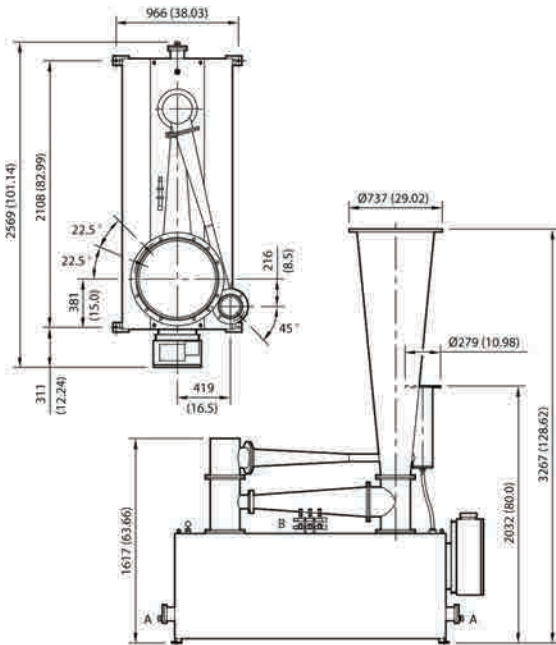

Applications

- Vacuum metallurgy
- Distillation, drying and degassing
- Thin film coating and metallizing
- Large-scale research

Performance Curves

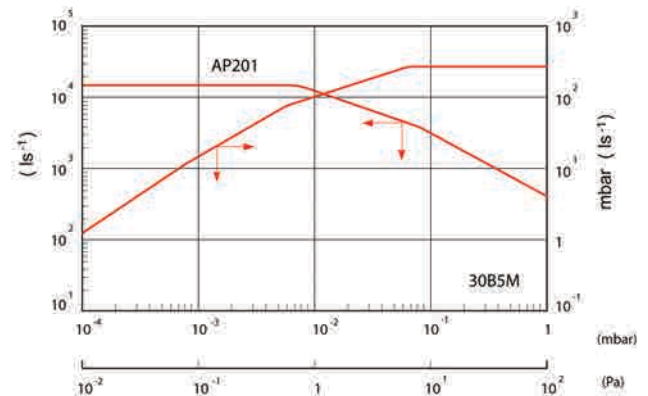

Technical Data

Pumping speed	
air	12500 ls ⁻¹
hydrogen	15000 ls ⁻¹
Maximum throughput	300 mbar ls ⁻¹
	225 Torr ls ⁻¹
Critical backing pressure	5.3-6 mbar
(with AP201 fluid)	4-4.5 Torr
Recommended backing pump displacement	290 m ³ h ⁻¹
	171 ft ³ min ⁻¹
Recommended backing pump†	GXS450, E2M275
Recommended fluid	Apiezon® AP201
Fluid charge	55 litre / 52 qt
Inlet connection	12 x 20.60 holes on 686.0 PCD
Backing connection	4 x 16.70 holes on 235.0 PCD
Water connection	1 inch BSP
Heater power	22.5 kW / 30 hp
Warming up time for full performance at maximum heater input	60 min
Minimum water flow inlet	2250 l h ⁻¹ @ 20°C
	9.9 US gal min ⁻¹ @ 20°C
Weight	620 kg / 1367 lbs

† These are given for guidance, please contact Edwards for a recommendation of pump combinations best suited for your application.

Ordering Information

Product Description	Order No.
30B5M, 380V, 3Ø, 50/60 Hz with Terminal Box	B06407380
30B5M, 400V, 3Ø, 50/60 Hz with Terminal Box	B06407400
30B5M, 415V, 3Ø, 50/60 Hz with Terminal Box	B06407415
30B5M, 440V, 3Ø, 50/60 Hz with Terminal Box	B06407440
30B5M, 460V, 3Ø, 50/60 Hz with Terminal Box	B06407460
30B5M, 480V, 3Ø, 50/60 Hz with Terminal Box	B06407480

Vapour Pumps for Scientific Instruments and R&D Applications

3

Page
130



Scientific and R&D applications require special vapour pumps and accessories. It is important to minimize any backstreaming of the vapour pump fluid, and the number of elastomer seals used in system design needs to be kept to a minimum, to give clean pumping with minimal outgassing. For bench-top or transportable instruments, compact air-cooled pumps are essential.

Edwards offers a range of vapour pumps and accessories which are designed to meet these needs.

Diffstak Vapour Diffusion Pumps

The compact water-cooled Diffstak pumps with an integral cooled baffle offer exceptionally clean pumping with very low backstreaming, reduced outgassing, and a reduction in the number of elastomer seals required for installation.

The Diffstak design has been proven over many years with thousands of pumps installed. They are supplied in two types: standard, and unvalved. (C – collar model pumps).

The Edwards Diffstak 63 (ISO 63 inlet), 100 (ISO100 inlet), 160 (ISO160 inlet), 250 (ISO250 inlet), design has been proven over many years with thousands of pumps installed.

The standard Diffstak pumps have integral high vacuum valves and water-cooled baffles, which are supplied as either manually operated (M-model pumps) or pneumatically operated (P-model pumps).

When comparing pumping speeds, note that the speeds quoted for valved Diffstaks are the speeds above the high vacuum valve, taking full account of the valve's impedance.

The unvalved Diffstaks are for systems requiring the highest possible ultimate vacuum or for those which do not need a high vacuum valve. All sizes are available with ISO flanges while two sizes are also available with CF flanges. (F – ConFlat® model pump).

The complete range is shown in the table below. Refer to the following pages for full technical data for each of the pumps and also for full details of installations, spares and accessories

Standard Diffstak	Unvalved Diffstak	
	ISO Flange	CF Flange
63/150M or P	63/150C	–
100/300M or P	100/300C	100/300F
160/700M or P	160/700C	160/700F
250/2000M or P	250/2000C	–

The following table shows the critical backing and ultimate pressures for the diffusion pump range:

Fluid	Critical Backing Pressure (mbar)	Ultimate Pressure (mbar)
Santovac® 5	0.6	5×10^{-9}
Silicone 702	1.2	7×10^{-6}
Silicone 704	0.8	7×10^{-8}
Silicone 705	0.6	3×10^{-8}

Data summary vapour pumps

Pump		63/150M 63/150P	63/150C
Pumping speed (M&P/C)			
Nitrogen	$l s^{-1}$	135	150
Hydrogen	$l s^{-1}$	200	225
Minimum backing pump displacement*	$m^3 h^{-1}$	5	5
Inlet connection		ISO63	ISO63
Backing connection		NW10	NW10
Oil charge capacity		60 ml	60 ml
Heater Power		450 W	450 W
Weight (M&P/C)		9 kg / 5 kg	9 kg / 5 kg

Pump		100/300M 100/300P	100/300C 100/300F
Pumping speed (M&P/C)			
Nitrogen	$l s^{-1}$	280	300
Hydrogen	$l s^{-1}$	500	535
Minimum backing pump displacement*	$m^3 h^{-1}$	5	5
Inlet connection		ISO100	ISO100 / 6 inch
Backing connection		NW25	NW25
Oil charge capacity		125 ml	125 ml
Heater Power		650 W	650 W
Weight (M/P/C/F)		12 kg / 13 kg / 9 kg / 10 kg	12 kg / 13 kg / 9 kg / 10 kg

Pump		160/700M 160/700P	160/700C 160/700F
Pumping speed (M&P/C)			
Nitrogen	$l s^{-1}$	700	760
Hydrogen	$l s^{-1}$	1300	1410
Minimum backing pump displacement*	$m^3 h^{-1}$	12	12
Inlet connection		ISO160	ISO160 / 8 inch
Backing connection		NW25	NW25
Oil charge capacity		250 ml	250 ml
Heater Power		1350 W	1350 W
Weight (M/P/C/F)		26 kg / 27 kg / 18 kg / 20 kg	26 kg / 27 kg / 18 kg / 20 kg

Pump		250/2000M 250/2000P	250/2000C
Pumping speed (M&P/C)			
Nitrogen	$l s^{-1}$	2000	2130
Hydrogen	$l s^{-1}$	3000	3200
Minimum backing pump displacement*	$m^3 h^{-1}$	40	40
Inlet connection		ISO250	ISO250
Backing connection		NW40	NW40
Oil charge capacity		500 ml	500 ml
Heater Power		2250 W	2250 W
Weight (M/P/C)		59 kg / 60 kg / 46 kg	59 kg / 60 kg / 46 kg

*. For maximum throughput. (63/150M and 63/150P – For applications where maximum throughput is not required, use an RV3.)

Ordering information

Product description	Order No.
Standard Diffstak 63/150M	
110-125 V 1-ph 50/60 Hz	B34431976
210-225 V 1-ph 50/60 Hz	B34431977
230-250 V 1-ph 50/60 Hz	B34431978
Standard Diffstak 63/150P	
110-125 V 1-ph 50/60 Hz	B34432976
210-225 V 1-ph 50/60 Hz	B34432977
230-250 V 1-ph 50/60 Hz	B34432978
Unvalved Diffstak 63/150C	
110-125 V 1-ph 50/60 Hz	B34433976
210-225 V 1-ph 50/60 Hz	B34433977
230-250 V 1-ph 50/60 Hz	B34433978
Supplied with: NW10 elbow, NW10 centring-ring, NW10 clamp, water pipe couplings and ferrules, inlet ISO 63 Co-Seal.	
Standard Diffstak 100/300M	
110-125 V 1-ph 50/60 Hz	B34631976
210-225 V 1-ph 50/60 Hz	B34631977
230-250 V 1-ph 50/60 Hz	B34631978
Standard Diffstak 100/300P	
110-125 V 1-ph 50/60 Hz	B34632976
210-225 V 1-ph 50/60 Hz	B34632977
230-250 V 1-ph 50/60 Hz	B34632978
Unvalved Diffstak 100/300C	
110-125 V 1-ph 50/60 Hz	B34633976
210-225 V 1-ph 50/60 Hz	B34633977
230-250 V 1-ph 50/60 Hz	B34633978
Unvalved Diffstak 100/300F	
110-125 V 1-ph 50/60 Hz	B34640976
210-225 V 1-ph 50/60 Hz	B34640977
230-250 V 1-ph 50/60 Hz	B34640978
Unvalved Diffstak 100/300D	
120V 1-ph 50/60Hz	B34642968
Supplied with: NW25 elbow, NW25 centring-ring, NW25 clamp, water pipe couplings and ferrules inlet ISO Co-Seal (C version only).	

Product description	Order No.
Standard Diffstak 160/700M	
110-125 V 1-ph 50/60 Hz	B34831976
210-225 V 1-ph 50/60 Hz	B34831977
230-250 V 1-ph 50/60 Hz	B34831978
Standard Diffstak 160/700P	
110-125 V 1-ph 50/60 Hz	B34832976
210-225 V 1-ph 50/60 Hz	B34832977
230-250 V 1-ph 50/60 Hz	B34832978
Unvalved Diffstak 160/700C	
110-125 V 1-ph 50/60 Hz	B34833976
210-225 V 1-ph 50/60 Hz	B34833977
230-250 V 1-ph 50/60 Hz	B34833978
Unvalved Diffstak 160/700F	
110-125 V 1-ph 50/60 Hz	B34840976
210-225 V 1-ph 50/60 Hz	B34840977
230-250 V 1-ph 50/60 Hz	B34840978
Supplied with: NW25 elbow, NW25 centring-ring, NW25 clamp, water pipe couplings and ferrules, inlet ISO 160 Co-Seal (C version only).	
Standard Diffstak 250/2000M	
110-125 V 1-ph 50/60 Hz	B35031976
210-225 V 1-ph 50/60 Hz	B35031977
230-250 V 1-ph 50/60 Hz	B35031978
Standard Diffstak 250/2000P	
110-125 V 1-ph 50/60 Hz	B35032976
210-225 V 1-ph 50/60 Hz	B35032977
230-250 V 1-ph 50/60 Hz	B35032978
Unvalved Diffstak 250/2000C	
110-125 V 1-ph 50/60 Hz	B35033976
210-225 V 1-ph 50/60 Hz	B35033977
230-250 V 1-ph 50/60 Hz	B35033978
Supplied with: NW40 elbow, NW40 centring-ring, NW40 clamp, water pipe couplings and ferrules, inlet ISO 250 trapped O-ring.	

Diffstak Installation

- M-model pumps have a manually operated high vacuum valve. P-model pumps have a pneumatically operated high vacuum valve. Both M-model and P-model pumps have inlet flanges which are compatible with ISO flanges: the internal diameter of the inlet flange is narrower and the flange is deeper than a standard ISO flange, to accommodate the high vacuum valve.
- C-model pumps do not have a high vacuum valve and have an ISO flange on the inlet.
- F-model pumps do not have a high vacuum valve and have a CF flange on the inlet.

Refer to the diagrams and the tables on these pages to identify the pipeline components and valves required to complete the typical Diffstak installation shown. Items supplied with the pump are shown as a dotted line. Read the footnotes below the diagrams and the tables for more information and for details of the installation requirements for the different models of Diffstaks.

3

Page
132

63/150, 100/300, 160/700 Installation

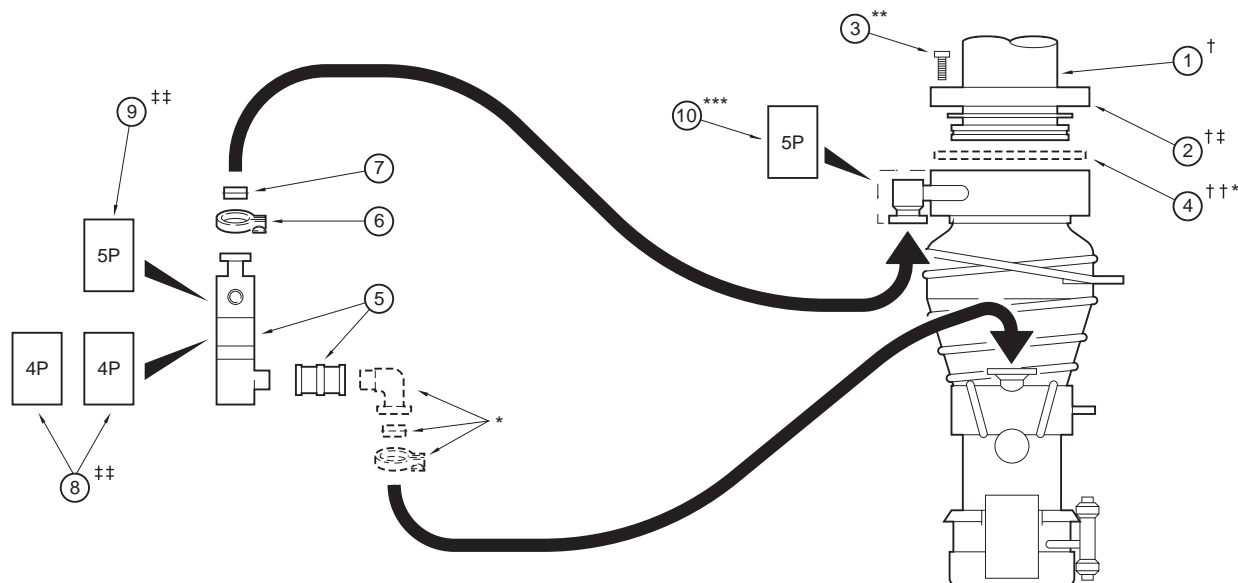

Diagram Key	Component Description	63/150 Component		100/300 Component		160/700 Component		
		Size	Quantity	Size	Quantity	Size	Quantity	
1 †	ISO tube/collar assembly	ISO63	1	ISO100	1	ISO160	1	
2 †‡	Rotable flange pack	ISO63	1	ISO100	1	ISO160	1	
3 **	Bolts (size x minimum length, mm)	M- and P-model	M8 x 75	4	M8 x 75	8	M10 x 90	8
		F-model	–	–	M8 x 55	16	M8 x 60	20
4 ††	Inlet seal	ISO63	1	ISO100	1	ISO160	1	
5	BRV valve, manual	BRV10M	1	BRV25M	1	BRV25M	1	
	BRV valve, pneumatic	BRV10P	1	BRV25P	1	BRV25P	1	
6	Clamp	NW10	1	NW25	1	NW25	1	
7	O-ring assembly	NW10	1	NW25	1	NW25	1	
8 ††	4-port light-weight electropneumatic control valve	–	2	–	2	–	2	
9 ††	5-port electropneumatic control valve	–	1	–	1	–	1	
10 ***	5-port electropneumatic control valve	–	1	–	1	–	1	

* These items are supplied with the pumps, except that the inlet seal for the F-model pumps is not supplied.

† Not required for F-model pumps; use CF fittings.

‡ Not required for C-model pumps; use claw clamps to bolt the pump ISO inlet flange directly to the ISO tube/collar assembly.

** Bolts are not available from Edwards. Bolts are not required for C-model pumps; use claw clamps to bolt the pump ISO inlet flange directly to the ISO tube/collar assembly; use 4 claw clamps for ISO63, ISO100 and ISO160 flanges.

†† These inlet seals are suitable for standard, C-model pumps only; use CF fittings for F-model pumps.

††† Required only for pneumatic operation BRV valves; use either 1 5-port control valve or 2 4-port control valves. If you use 2 4-port control valves, you can use the isolation position of the BRV valve.

*** Required only for P-model pumps, to control the operation of the high vacuum valve.

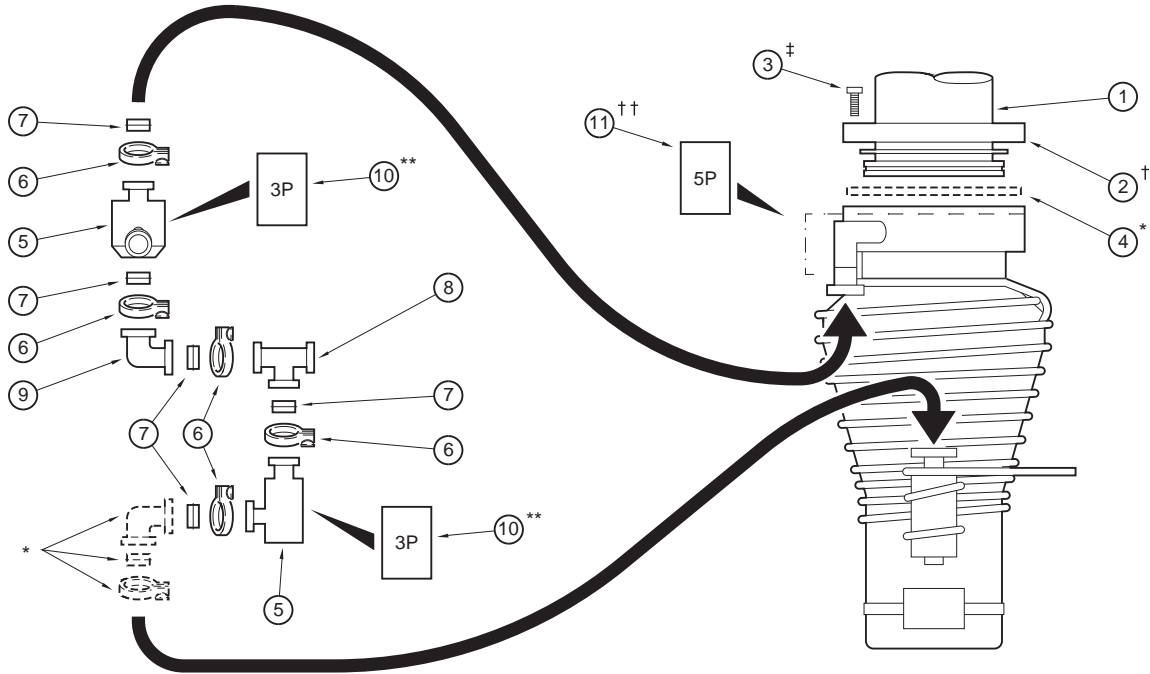

Diagram Key	Component Description	Component Size	Component Quantity
1	ISO tube/collar assembly	ISO250	1
2 †	Rotatable flange pack	ISO250	1
3 ‡	Bolts (size, minimum length, mm) M- & P-model	M10 × 110	12
4	Inlet seal, trapped O-ring	ISO250	1
5	PV40 valve, manual	PV40MK	2
	PV40 valve, pneumatic	PV40PK	2
6	Clamp	NW40	5
7	O-ring assembly	NW40	5
8	T-piece	NW40	1
9	Elbow	NW40	1
10 **	3-port electropneumatic control valve		2
11 ††	5-port electropneumatic control valve	–	1

* These items are supplied with the pump.
 † Not required for C-model pumps; use 6 claw clamps to bolt the pump ISO inlet flange directly to the ISO tube/collar assembly.
 ‡ Bolts are not available from Edwards. Bolts are not required for Model-C pumps; use 6 claw clamps to clamp the pump ISO inlet flange directly to the ISO tube/collar assembly.
 ** Required only for pneumatic operation PVPK valves; use 1 3-port control valve for each of the two PVPK valves.
 †† Required only for P-model pumps, to control the high vacuum valve.

Vapour Pump Spares

3

Page
134

Product description	Order No.
Diffstak 63 Heater (0.45 kW)	
110-125 V	H01700182
210-225 V	H01700186
230-250 V	H01700191
Diffstak 100 Heater (0.4 kW)	
120 V	H01700226
Diffstak 100 Heater (0.65kW)	
110-125 V	H01700199
210-225 V	H01700097
230-250 V	H01700190
Diffstak 160 Heaters (one of each power required)	
110-125 V 0.35 kW	H01700102
210-225 V 1 kW	H01700059
230-250 V 0.35 kW	H01700107
210-225 V 1 kW	H01700063
230-250 V 0.35 kW	H01700113
230-250 V 1 kW	H01700054
Diffstak 250 Heaters (one of each power required)	
110-125 V 0.85 kW	H01700140
110-125 V 1.4 kW	H01700161
210-225 V 0.85 kW	H01700134
210-225 V 1.4 kW	H01700155
230-250 V 0.85 kW	H01700137
230-250 V 1.4 kW	H01700158
HT10 Heater 1700 W, 50/60 Hz, 3-ph (three required)	
200 V	H01706010
220 V	H01706011
380 V	H01706012
400 V	H01706013
415 V	H01706014
460 V	H01706015
480 V	H01706016
HT16B Heater, 1500 W, 50/60 Hz, 3-phase (six required)	
200 V	H01706020
220 V	H01706021
380 V	H01706022
400 V	H01706023
415 V	H01706024
440 V	H01706028
460 V	H01706025
480 V	H01706026
HT20B Heater, 1400 W, 50/60 Hz, 3-phase (nine required)	
200 V	H01706113
220 V	H01706114
380 V	H01706115
400 V	H01706116
415 V	H01706117
440 V	H01706118
460 V	H01706119
480 V	H01706120

This page is intentionally left blank.

3

Page
136

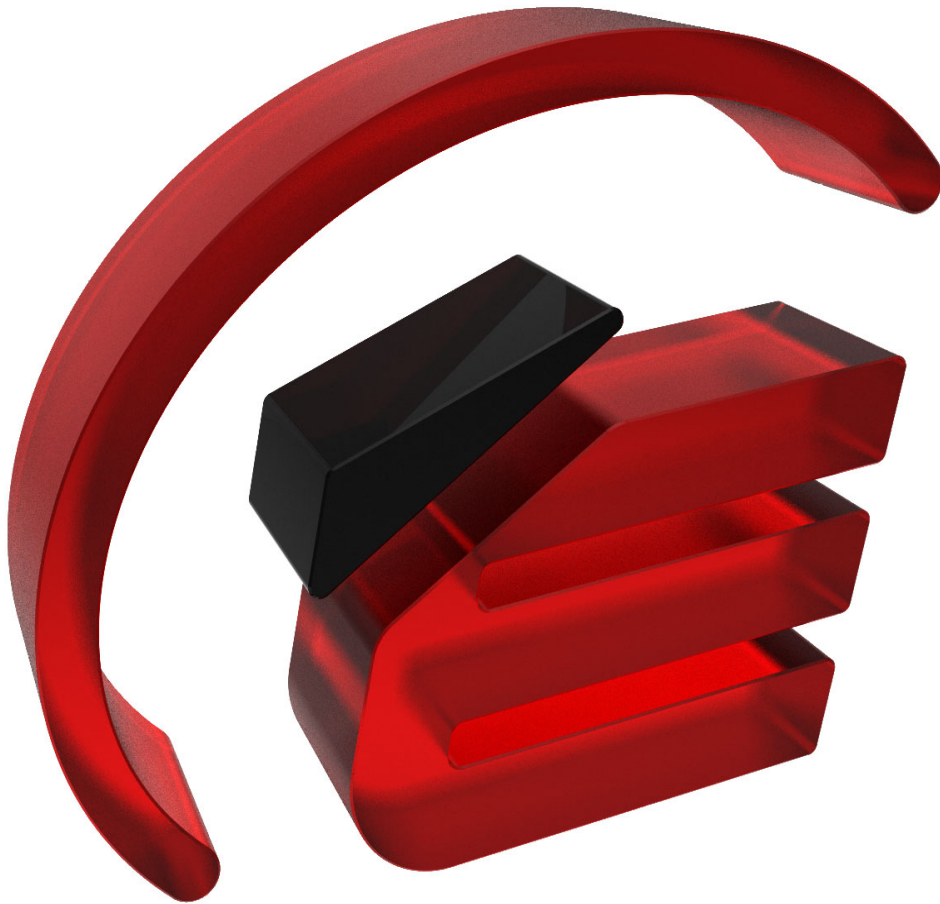



TIC Instrument Controllers	140
Profibus Communications Module	142
ADC Active Digital Controllers	144
APG100 Active Pirani Vacuum Gauge	146
APGX-H Active Linear Convection Gauges	148
ATC Active Thermocouple Gauge	150
ASG Active Strain Gauge	152
AIM Active Inverted Magnetron Gauge	156
WRG Active Wide Range Gauge	158
AIGX Active Ion Gauge	160
Model 1575 Pressure Display	162
CG16K Capsule Dial Gauge	163
IS16K Vacuum Interlock Switch	164
VS16K Adjustable Vacuum Switch	165
Gascheck Leak Detectors	166

Vacuum Measurement and Control Systems

The Edwards range of instruments offers:

- Measurement over the range 2000 to 10^{-11} mbar
- Advanced microprocessor based controllers
- Calibration of instruments to UK national standards

Selecting Your Vacuum Gauge

Edwards offers a wide choice of vacuum measurement and control products – from dial gauges to microprocessor based gauge controllers. Within each product range, there is a family of models designed to meet the widest user specification.

The first step in selecting the right gauge to meet your application is to decide the range of pressures that you want to measure at each of your measuring points. The chart below indicates the broad pressure ranges covered by the spectrum of Edwards instruments: use this chart as a primary guide to the choice of gauge head.

The second step is to establish your requirement for the output of the pressure measurement. If you simply want an indication that a certain level of vacuum has been reached (for example, to open a valve or start a process), then a vacuum switch or Active gauge head alone may be appropriate. If you want to display the pressure locally, then a dial gauge may be suitable. If you need the pressure display to be remote from the measurement point (for example, in a control panel) then select the TIC Instrument Controller or Active Digital Controller, depending on the features you require. (You will also need to select appropriate gauge head(s) to accompany these displays and controllers.) If your control system (such as a PLC, PC or dedicated microprocessor controller) needs to know the pressure to make sequence decisions but you do not need a separate vacuum display, then you can use an Active gauge head as a stand-alone transducer connected to an appropriate power supply and control system analog input.

Thirdly, you need to select a gauge suitable for the process gases and constructed to withstand exposure to the external environment of your vacuum system. Consider both whether the gauge will survive in the process and also whether the process gases will effect the gauge's measurement. For example, the measurement made by mechanical gauges (vacuum switches, dial gauges, strain gauges and capacitance manometers) is not affected by gas composition, whereas that made by other types of gauges is gas dependent.

Calibration for Different Gases

All of our gauge heads are calibrated for dry nitrogen; the calibration for dry air is the same. If you use thermal conductivity or ionization gauges with gases other than nitrogen or air, you may need to apply a gas correction factor for an accurate indication of your system pressure. Please contact us if you need more information.

Gauge Head Installation

How you install the gauge head into your vacuum system will affect the accuracy and reliability of your pressure measurement. For best performance we recommend that you:

- Connect the gauge head to your vacuum system with a straight, short branch pipe. This pipe should have an internal diameter no less than that of the gauge tube itself. Long, narrow or angled connections can cause a significant measurement error. Note that the indicated pressure may be higher or lower than the actual pressure.
- Connect the gauge head as close as possible to the point where you want to measure the system pressure.
- Orientate the gauge head so that it is vertical, with the connection to the vacuum system at its base. This prevents debris falling into the gauge.

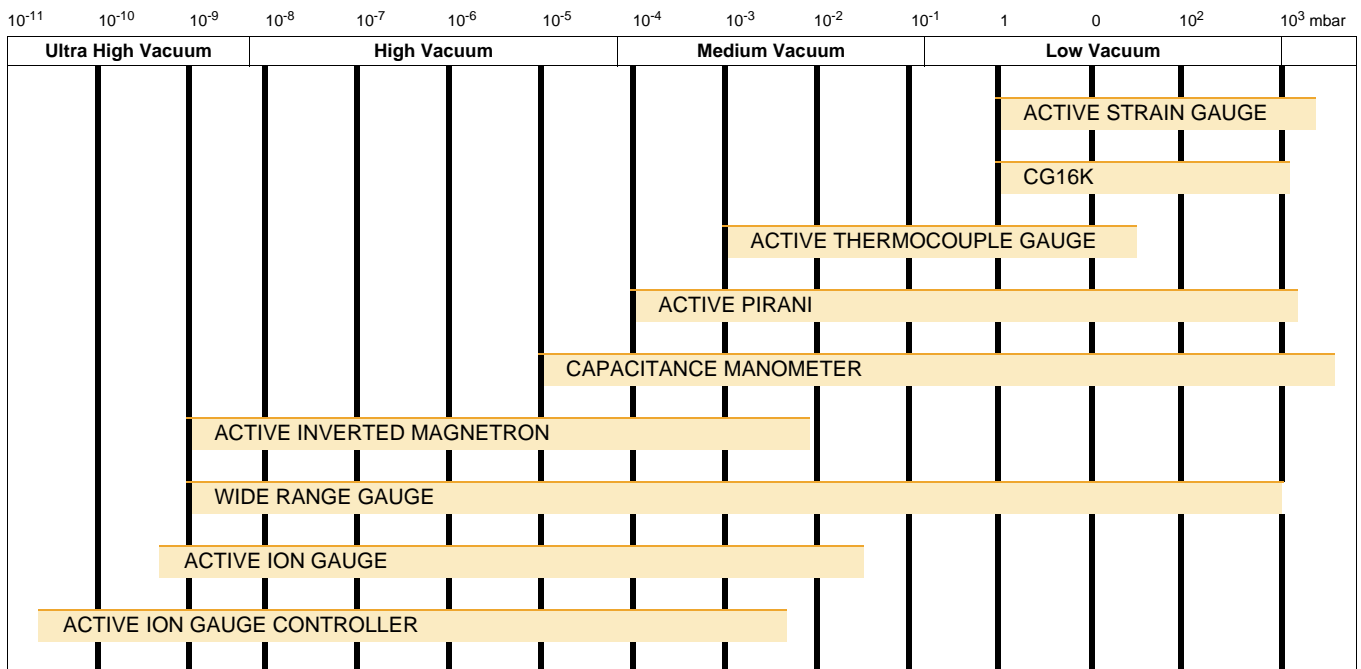

The Active Gauge Concept



- Operate from standard power supplies for simple installation
- Gauge type identification signal and common 0-10 V d.c. output
- Cable lengths of up to 100 m for remote operation
- Range of microprocessor based controllers
- The Active gauge range with TIC Instrument Controller give continuous measurement from 2000 mbar to 10^{-11} mbar
- Low cost analog and digital displays and controllers available

Edwards Active vacuum gauges and controllers give unrivalled performance, flexibility and ease of use. Traditionally, vacuum gauges consisted of a sensing element and a separate display/controller. With Edwards' Active gauges, the functions that are specific to the gauge type (such as signal conditioning and specialized power supplies) have been moved from the dedicated controller and incorporated in the head itself. Now the gauge head can be used as a stand-alone transducer: it requires only a simple power supply and it provides a 2 to 10 V output. Alternatively, you can connect the gauges to a Edwards display or universal controller: these will accept all gauge types in any combination for the most flexible solution.

The Active Gauge Range

Active Pirani Gauge A range of Pirani gauges including linear measuring from above atmospheric pressure to 10^{-4} mbar, with integral set-point for OEM use.

Active Ion Gauge A new range of small self-contained Active ion gauges with a measuring range from 5×10^{-2} to 5×10^{-10} Torr. The gauges incorporate degas, automatic emission current switching, automatic filament protection, a push button adjustable set point and status indicating LED.

Active Inverted Magnetron Operating through the range 10^{-2} mbar to 10^{-9} mbar, with integral set-point for OEM use. A low external magnetic active field version is available.

Active Wide Range Gauge A range of gauges measuring from atmosphere to 10^{-9} mbar with a linear output and integral set-point for OEM use. A low external magnetic field version is available.

Active Thermocouple Gauge A range of gauges measuring from atmosphere to 10^{-3} mbar, with integral set-point for OEM use and LED indication of vacuum status.

Active Strain Gauge A range of strain gauges measuring from 2000 mbar to 1 mbar. This type of gauge is extremely rugged and offers accurate, gas independent measurement.

Barocel Capacitance Manometers

The Barocel manometers provide high accuracy, high stability, gas independent pressure measurement making them ideal for a wide range of industrial process, research and calibration applications. Their Inconel/Monel construction means that they can also be used with corrosive and radioactive gases.

- Accuracy 0.15% of reading
- True total pressure measurement, independent of gas species
- Very high corrosion resistance
- Fast response
- Wide range, 4 decade range with single head
- Temperature controlled manometers from 45 °C
- Excellent stability
- Full scale ranges from 1 mbar to 1000 mbar (0.05 Torr to 1000 Torr)

Active Controllers and Displays

The Edwards Active range of gauges can operate as stand-alone pressure transducers requiring only a simple power supply and providing a 2 to 10 V analog output. If you need a complete vacuum measuring and display system, we also offer a range of controllers and displays.

Our displays and controllers are designed for maximum flexibility and ease of use. The range is suitable for bench-top or panel mounting and options include RS232 interfacing.

TIC Instrument Controller A compact instrument controller with a large clear graphical display, an intuitive user interface and serial communications providing full remote control and data logging functions for one or more TIC systems via a new Windows™ based PC program.

The controller supports, automatically recognises and controls up to six gauges from the Edwards range (including IGC and up to three Barocels), with coverage from 2000 to 6.6×10^{-10} mbar. Low pressure gauges may be controlled and protected by high pressure gauges and there are open collector set point outputs. An optional relay box uses these outputs to control mains changeover relays.

The TIC instrument controller may be either rack or bench mounted and provides a useful hub for the flexible operation of a wide range of vacuum system configurations.

Active Digital Controller The Edwards Active Digital Controller (ADC) is a compact single gauge controller and display. It features a bright LED display and simple push-button controls. The ADC automatically recognises compatible Edwards gauges, loads the appropriate look-up table and displays the pressure in commonly used vacuum units.

The ADC is available in standard and enhanced versions. The standard controller displays the pressure measured by a single active gauge. The enhanced controller supports two similar gauges – it has two variable hysteresis set-points which are linked to 48 V d.c. 1 A changeover relays and two 0-10 V d.c. analog outputs. To aid system integration, the enhanced controller is provided with an RS232 interface.

When combined with a suitable gauge, such as the Edwards APGX-H Convection Pirani or Wide Range Gauge (WRG), the ADC represents a cost effective means of monitoring and controlling process vacuum in a broad range of applications.

Other Instruments

In addition to the range of Active gauges, Edwards offers a variety of more traditional vacuum measurement and control products.

Our simple dial gauges provide rugged, local indication of pressures from atmosphere to 1 mbar and are ideal for vacuum chambers in an industrial environment. Vacuum switches, with high current ratings, give a simple method of directly controlling loads without the need for additional relays or power supplies.

Gauge Calibration Service

All Edwards gauges may either be supplied with a calibration certificate or re-calibrated by request.

- Provides certificate of calibration traceable to National Standards which meets ISO9000 requirements worldwide
- Service available for both new and returned instruments
- Transducers calibrated separately or with display/controller

As a leading manufacturer of vacuum instruments, Edwards offers an expert calibration and repair service with 25 years of experience. Other manufacturers' vacuum instruments including Helium leaks are also covered. The instruments are calibrated with dry nitrogen; for calibration with other gases or at specific pressures, please consult Edwards. The option of calibration figures before and after adjustments and repairs is also available.

The range of instruments include:

- Active gauges, displays and controllers. Note that Active gauges can be calibrated on their own, with a display or with a controller.
- Capacitance manometers. Note that some types of manometers can be calibrated as stand-alone instruments, with a controller or with a pressure monitor, for example the TIC Instrument Controller.
- Helium quartz leaks for mass spectrometer leak detectors.

Contact Edwards for details.



The TIC Instrument Controller provides compact control with a large, clear graphical display, an intuitive user interface and serial communications. The supplied Windows™-based PC program provides full remote setup, control and data logging functions via the RS232 interface.

Three TIC Instrument Controllers are available; the three head and six head versions can accommodate 3 or 6 active gauges. The six head capman version can accept up to three Edwards Barocel® Capacitance Manometers.

4 Features & Benefits

Page 140

- TIC automatically recognizes and controls active gauges including APG100 Pirani, convection, thermocouple, strain, inverted magnetron, wide range and active ion gauges. To enable complete integration into PC and PLC controlled processes, all TIC variants include RS232 and RS485 interface.
- TIC has six pressure related set points, which operate open collector outputs rated at 24 V d.c. 50 mA. Using the optional relay boxes, these may be linked to 250 V a.c. changeover relays to provide a useful accessory control capability. All relay boxes include a logic bypass facility for further system integration.
- In most instances, TIC systems may be simply and quickly configured using the range of standard cables on offer, there is therefore no need for the customer to prepare loom assemblies or relay boxes and special interfaces.
- TIC includes lookup tables for a range of commonly encountered process gasses (N₂, He, Ar, CO₂, Kr & Ne). Selecting the appropriate gas enables direct readout of the correct pressure without the need to apply conversion factors.
- TIC is packaged in a compact case and may be panel or rack (¼ 19 inch rack 3U) mounted. With the addition of the bezel it becomes an attractive bench-top instrument. The large 128 x 64 pixel backlit graphics LCD and mobile phone style menu system simplifies programming and with a choice of summary screens excellent visibility of displayed parameters is assured.

Dimensions

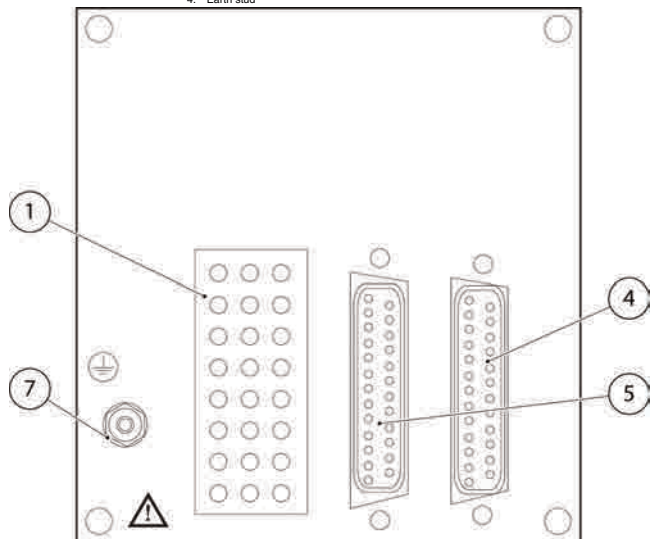
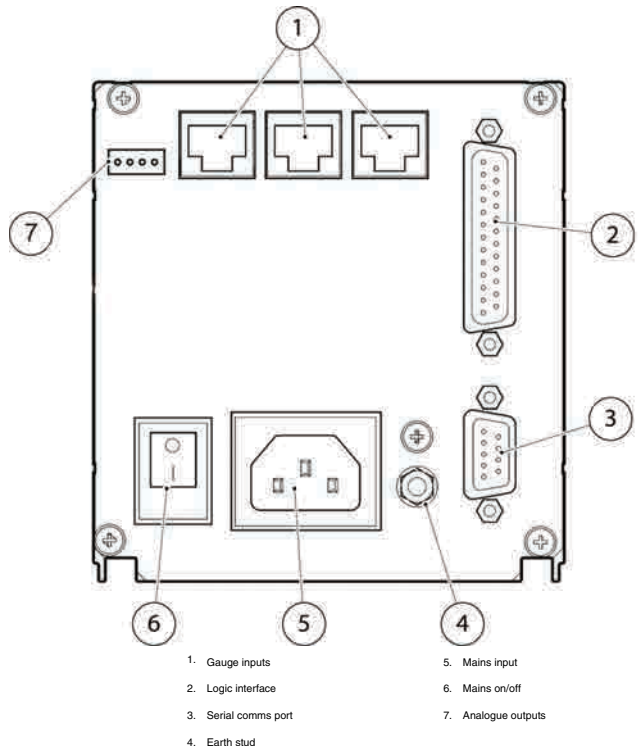

This is the 6 set point version; the 3 set point version is similar.

Technical Data

Electrical Data	
Connector type	CEE/IEC 320
Electrical supply	90 to 264 V AC, 47 to 63 Hz
Power consumption	3 head TIC 55 VA. 6 Head TIC 160 VA
Fuse	The unit is self-protecting and has no user replaceable fuse. The unit will recover once any overload is removed.
Earth stud	M4
Operating And Storage Data	
Ambient operating temperature range	0 °C to 40 °C (measured underneath TIC)
Maximum ambient operating humidity	Max 90% RH non-condensing at 40 °C
Maximum operating altitude	3000 m max
IP rating	20
IEC rated pollution degree	2
Mechanical Data	
Weight	1.7 Kg
Interfaces	
Analogue output	0-10 V DC – one for each gauge
Serial Interface	The TIC has two built-in communications protocols, RS232 and RS485. These may be used either to interface to a PLC or, using the Windows™ PC software package supplied, connected to a PC for full monitoring and control of a TIC system.
Set-points	6 set-point (open collector) rated at 24V DC 50 mA can be assigned to any gauge. Use directly or in conjunction with TIC relay boxes.

Capacitance manometer compatibility – 6 head capman versions only
 3 x 600 series Barocel®
 2 x 655 series Barocel®
 For more information, contact Edwards.

Ordering Information

Product Description	Order No.
TIC Instrument Controller 3 Head RS232/RS485	D39700000
TIC Instrument Controller 3 Head RS232/RS485, Certificated	D3970000C
TIC Instrument Controller 6 Head RS232/RS485	D39701000
TIC Instrument Controller 6 Head Capman	D39702000
TIC Instrument Controller 6 Head RS232/RS485, Certificated	D3970100C
TIC Instrument Controller 6 Head Capman, Certificated	D3970200C
Accessories & Spares	Order No.
0.5M Active Gauge Cable	D40001005
100M Active Gauge Cable Assembly	D40001999
10M Active Gauge Cable	D40001100
15M Active Gauge Cable	D40001150
1M Active Gauge Cable	D40001010
25M Active Gauge Cable	D40001250
3M Active Gauge Cable	D40001030
50M Active Gauge Cable	D40001500
5M Active Gauge Cable	D40001050
Linecord 2M North Euro Plug	D40013030
Linecord 2M UK Plug	D40013025
Linecord 2m With US Plug	D40013120
TIC front bezel kit	D39700803
TIC Logic Interface Cable 2m	D39700833
TIC Relay Box Instruments (3 x 3A, 250V)	D39700804
TIC Relay box instruments (6 x 5 A, 250 V)	D39701804
TIC RS232 Interface Cable 2m	D39700834

Profibus Communications Module



Manufacturers, laboratories and research establishments are converting to fieldbus to take advantage of the reduced cabling and network equipment costs.

Edwards offers a compact, Din rail mountable module to allow Profibus protocol communications with the TIC Turbo and Instrument Controllers, or directly with Edwards DX/nEXT turbo pumps.

The TIC is a versatile, advanced system controller capable of controlling a series of vacuum pumps and up to three Edwards Active vacuum gauges. The addition of the Profibus module allows full advantage to be taken of digital multi-drop communications.

4 Features & Benefits

Page
142

- Full Profibus International Accreditation
- Din Rail Or Rack Mounting
- Wide Operating Voltage Range 9 - 52 V
- Simple Set-up
- Field Software Upgrades Available

Dimensions

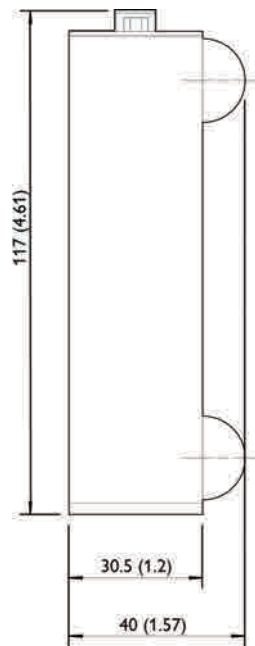

Technical Data

Electrical Data

Electrical supply

TIC Profibus module	9 - 52 V DC 5W (switch on surge 500 mA)
Ambient operating temperature	0 to 40 °C
Ambient storage temperature	-30 to 70 °C
Max ambient operating humidity	90% RH non-condensing
Max operating altitude	2000 m
IP rating	IP30 - indoor use only
Mass	0.28 kg

Connectors

DC power connector (supplied)	2-way receptacle. Mating part is cable mount terminal block (supplied). Suitable parts include: Phoenix MSTBV 2.5/2-G-5.08; Weidmuller BLZ 5.08/2; Amp796634-2; IMO 21.950/2
Profibus connector	
Connector type	9-way sub-miniature "D" type socket
Profibus data signals	Electrically compliant with RS485 specification isolated from chassis
Profibus power supply	10 mA supply (protected for external terminator resistors if required)
Chassis	For Profibus cable screen convention
Repeater control signal	Digital signal, nominally 0-5 V but with series 340 ohm resistor. High = module transmitting. Low = receiving or idle
RS232 connector TIC version	9-way sub-miniature "D" type plug
RS232 protocol	9600 baud, 1 stop bit, 8 data bits, no parity
RS232 protocol	9600 baud, 1 stop bit, 8 data bits, no parity

Cables

Profibus cable	Should be screened and comply with EN50170
RS232 cable TIC version	15 m max. Screening not required.
DX pump connection	Connection must be either directly to the DX pump flying lead or an Edwards DX pump extension cable.

Ordering Information

Product Description	Order No.
TIC Profibus Communications Module	D39754000
DX/nEXT Pump Profibus Communications Module	D39755000



The Edwards Active Digital Controller (ADC) is a compact single gauge controller and display. It features a bright LED display and simple push-button controls. The ADC automatically recognizes compatible Edwards gauges, loads the appropriate look-up table and displays the pressure in commonly used vacuum units.

Two versions are available; the standard ADC simply displays the pressure in choice of units, and the enhanced ADC includes a second gauge connection, two set-point relays, two analogue outputs and an RS232 interface.

The ADC mk2 enhanced controller can now support 2 different gauges e.g. APG100 and AIM.

4 Features & Benefits

Page
144

- Plug and measure operation means you simply plug in the mains supply, connect the gauge and ADC displays the measured pressure
- The ADC supports Edwards gauges with a total measuring range of 2000 to 1×10^{-9} mbar (1500 to 7.5×10^{-10} Torr)
- Bright LED display gives clear, long distance readability
- The ADC displays units in mbar, Torr, Pascal or Volts
- Small 1/8 DIN enclosure, may be panel or bench mounted

Dimensions

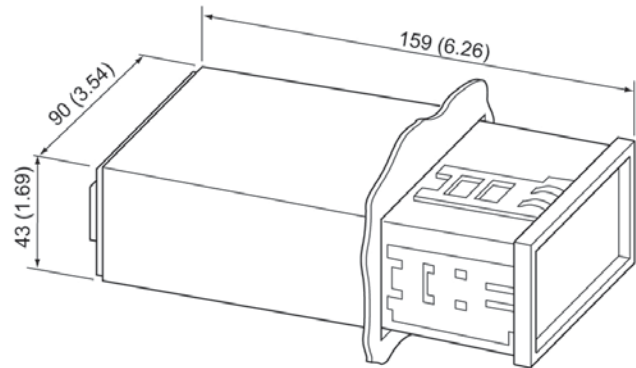

Technical Data

Active gauge compatibility	
Standard	APG100, APG-L, APG-MP, APG-M, APGX-H, APGX-L, WRG
Enhanced	Up to two gauges from the standard version plus AIM-X, AIM-S & ASG
Display	High brightness green LED display (0.47 inch high) Units - mbar/Torr/Pa/Volts
Electrical supply	100 to 240V AC 47 to 63 Hz
Dimensional Data	
Panel cut-out	92 + 0.8 x 45 + 0.6 mm (3.62inch x 1.77 inch) to DIN43700
Panel thickness	1.5mm (0.06 inch) Min
Weight	0.33Kg
Operating and storage data	
Operating temperature	+0 to +40°C
Storage temperature	-30 to +70°C
Max ambient operating humidity	90% RH non condensing at 40°C
Standards	
Electrical safety	BS EN 61010-1
Electrical noise immunity	BS EN 61326 (Industrial location, class B emissions)
Flame retardant case materials	UL94 V1
Enclosure rating	IP40
Enhanced features	
Two analogue output	0-10V d.c.
Two set-point relays, volt free single pole change-over	1A at 48V d.c. / 2A at 24V d.c.
Serial output	RS232

Ordering Information

Product Description	Order No.
ADC Standard	D39590000
ADC mkII Enhanced	D39591500
ADC Standard, Certificated	D3959000C
ADC mkII Enhanced, Certificated	D3959150C
Accessories & Spares	Order No.
0.5M Active Gauge Cable	D40001005
100M Active Gauge Cable Assembly	D40001999
10M Active Gauge Cable	D40001100
15M Active Gauge Cable	D40001150
1M Active Gauge Cable	D40001010
25M Active Gauge Cable	D40001250
3M Active Gauge Cable	D40001030
50M Active Gauge Cable	D40001500
5M Active Gauge Cable	D40001050
Linecord 2M North Euro Plug	D40013030
Linecord 2M UK Plug	D40013025
Linecord 2m With US Plug	D40013120
TIC RS232 Interface Cable 2m	D39700834

APG100 Active Pirani Vacuum Gauge



Features include compact size for easy installation, a linear output, and a replaceable sensor tube. The new gauges are compatible with all Edwards TIC instrument controllers and other active gauge controllers and displays. They are also CSA, C/US approved as well as fully RoHS compliant due to their lead-free construction.

4 Features & Benefits

Page 146

- Cable connections and gauge adjustment conveniently located, thereby minimizing the space envelope required for access
- Sensor tube can be baked to 150 °C
- Adjustable set-point for simple process control and interlocking
- Remote calibration possible
- CSA, C/US approved

Performance Curves

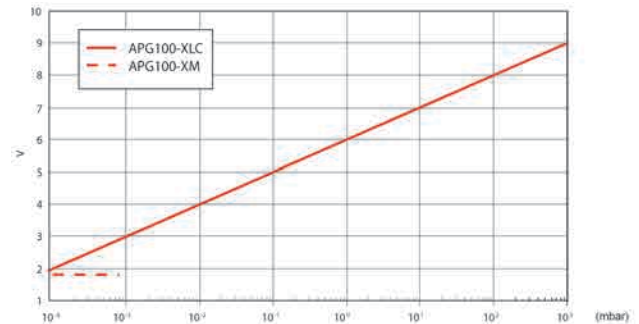

Dimensions

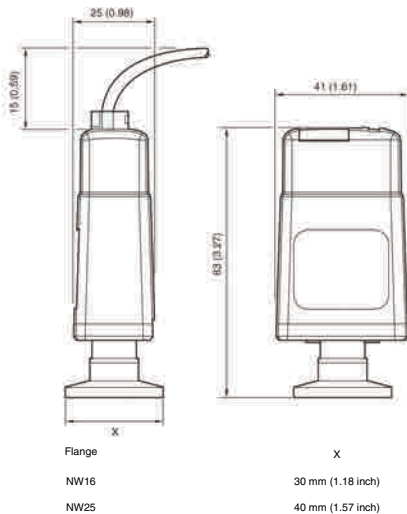

Ordering Information

Product Description	Order No.
APG100-XM, NW16	D02601000
APG100-XM, NW25	D02602000
APG100-XLC, corrosion resistant, NW16	D02603000
APG100-XLC, corrosion resistant, NW25	D02604000
APG100-XM, NW16, Certificated	D0260100C
APG100-XM, NW25, Certificated	D0260200C
APG100-XLC, NW16, Certificated	D0260300C
APG100-XLC, NW25, Certificated	D0260400C
APG100-XM, DN16CF	NRD710000
APG100-XLC, DN16CF	NRD712000
Accessories & Spares	Order No.
Spare APG100-XLC electronics module	D02603800
Spare APG100-XM electronics module	D02601800
Spare mesh filter for APG100 pack of 5	D02601805
Spare sensor for APG100-XLC NW16 flange	D02603801
Spare sensor for APG100-XLC NW25 flange	D02604801
Spare sensor for APG100-XM NW16 flange	D02601801
Spare sensor for APG100-XM NW25 flange	D02602801
Spare sensor for APG100-XM DN16CF flange	NRD711000
Spare sensor for APG100-XLC DN16CF flange	NRD713000

Technical Data

Mass	85 g
Internal volume	5 cm ³
Enclosure rating	IP40
Measurement range (APG100-XM)	Atmosphere to 10 ⁻³ mbar
Measurement range (APG100-XLC)	Atmosphere to 10 ⁻⁴ mbar
Accuracy (APG100-XM)	Typically +/- 15% at <100 mbar
Accuracy (APG100-XLC)	Typically +/- 15% at <10 mbar
Maximum over-pressure	10 bar absolute
Operating temp range	5° to 60° C
Storage temp range	-30° to 70° C
Bake-out with no electronics	150° C
Humidity	80% RH up to 31° C decreasing linearly to 50% RH at 40° C and above
Maximum altitude	3000 m
Filament temperature	100° C above ambient
Electrical supply voltage	15 to 30 V d.c. nominal 13.5 V d.c. minimum 32 V d.c maximum
Power consumption	1 W
Output signal	0 to 10 V d.c. nominal
Set-point – open collector transistor	
Rating	30 V d.c. 100 mA
Range of set-point	1.8 to 9.2 V dc
Fixed hysteresis	500 mV (1/2 decade)
Level setting resolution	6 mV

APGX-H Active Linear Convection Gauge



Edwards Linear Convection Vacuum Gauge has a wide measuring range from 1333 to 3×10^{-4} mbar (1000 to 2.3×10^{-4} Torr). The use of convection technology ensures accuracy and sensitivity are maintained to the top of the range.

The gauge is compact and may be mounted in any orientation, simplifying installation where space is limited. The gauge incorporates a setpoint and two LEDs, which indicate setpoint and gauge status.

4 Features & Benefits

Page 148

- Wide Measuring Range 1333 to 3×10^{-4} mbar (1000 to 2.3×10^{-4} Torr)
- Use of convection technology ensures consistent measuring accuracy (typically $\pm 15\%$) and repeatability ($\pm 5\%$) to top of range
- Reduced Cost of Ownership
- Replaceable tubes are available
- CSA, C/US Approved

Dimensions

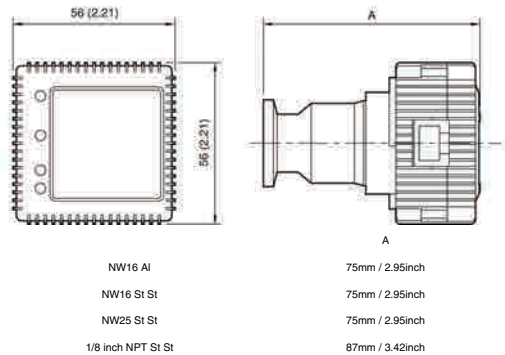

Performance Curves

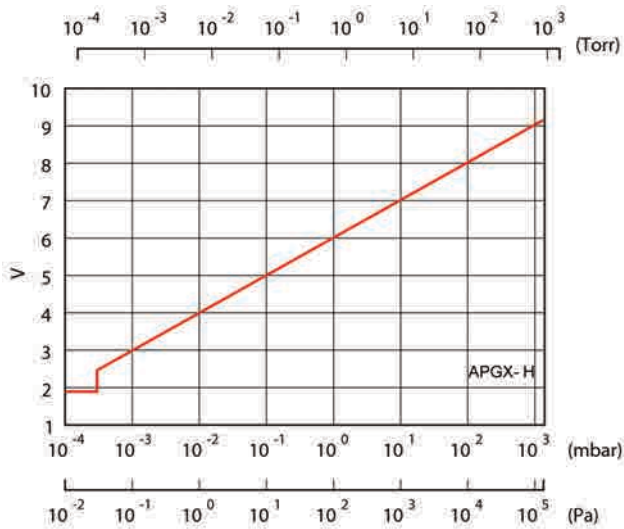

Technical Data

Pressure range	1333 to 3×10^{-4} mbar (1000 to 2.3×10^{-4} Torr)
Power supply	14.5 to 30 V DC
Power consumption	1.5 W maximum
Accuracy	$\pm 15\%$ of reading $\pm 3 \times 10^{-4}$ mbar
Repeatability	$\pm 5\%$ of reading
Resolution	6mV increments
Response time	< 100 ms
Maximum overpressure	10 bar absolute (145 psia)
Adjustments	Set vacuum and set atmosphere. To allow for variations in barometric pressure, atmosphere may be set in the range 700 to 1100 mbar (525 to 825 Torr).
Setpoints† (open collector transistor)	Range of setpoint 1.8 to 9.3 V Rating 30 V DC 100 mA Fixed hysteresis (1/2 decade) 500 mV

† The setpoint output will be turned off if an error is detected. For further information, please contact Edwards.

Ordering Information

Product Description	Order No.
APGX-H-NW16, aluminium	D02391000
APGX-H-NW25 ST/ST	D02392000
APGX-H-NW16 ST/ST	D02395000
APGX-H 1/8" NPT ST/ST	D02396000
APGX-H-NW16 Aluminium, Certificated	D0239100C
APGX-H-NW16 ST/ST, Certificated	D0239500C
APGX-H-NW25 ST/ST, Certificated	D0239200C
APGX-H 1/8" NPT ST/ST, Certificated	D0239600C
Accessories & Spares	Order No.
0.5M Active Gauge Cable	D40001005
100M Active Gauge Cable Assembly	D40001999
10M Active Gauge Cable	D40001100
15M Active Gauge Cable	D40001150
1M Active Gauge Cable	D40001010
25M Active Gauge Cable	D40001250
3M Active Gauge Cable	D40001030
50M Active Gauge Cable	D40001500
5M Active Gauge Cable	D40001050
AGC EPROM Upgrade Kit	D38660800
APGX-H Electronics Module	D02391800
APGX-H Filter Pack 5 (not NPT version)	D02391805
NW16 AL TUBE APGX-H SPARE	D02391801
NW16 STST TUBE APGX-H	D02395801
NW25 STS TUBE APGX-H SPARE	D02392801
Spare Tube 1/8" NPT ST/ST	D02396801

ATC Active Thermocouple Gauge



The Edwards Active Thermocouple (ATC-E) gauges mount directly on either the ATC-D or ATC-M thermocouple tubes to form a compact, stand-alone transducer.

The ATC-E electronics module drives both medium and low pressure gauge tubes. These gauges offer a cost effective measuring solution for higher pressures.

4 Features & Benefits

Page 150

- Drive electronics mount directly on the gauge tube which simplifies the system design and saves valuable rack space
- Wide range, regulated, internal power supply runs from standard d.c. power supplies from +13.5 to +36 V and is tolerant to voltage fluctuations
- Standard analogue outputs of 0 to +10 V d.c. and gauge identifier allows for easy interface with a computer or PLC and provides fault output indication
- Adjustable set-point with vacuum status LED can be used for process control and interlocking and includes a digital vacuum status signal with set-point level ready visually
- Low output impedance and integral Faraday shield provides a high level of noise immunity and permits long cable runs of up to 100 meters

Dimensions

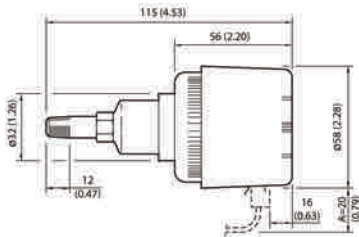

A. Allowance for cable and connector

Applications

- Active thermocouple gauges are ideally suited to applications where a simple rugged gauge is required to measure higher pressures.

Performance Curves

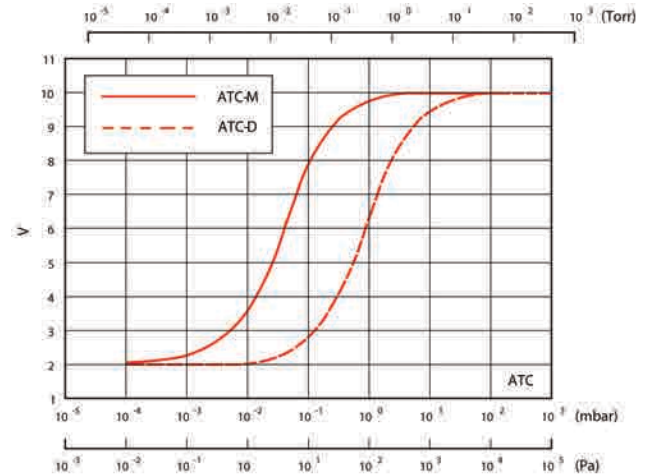

Technical Data

ATC-E Electronics Module

Power supply	+13.5 to +36 V d.c. (max 1 V ripple)
Power consumption	0.54W maximum
Output signal	
Operating	2 to 10 V d.c.
Fault output	0 to 2 V d.c., 10 to 13.5 V d.c.
Output impedance	0.1 ohms
Minimum load	10 k ohms

Tube Type Selection

Adjustments	Adjust set point visually via potentiometer
Set point	Open collector transistor
Range of set point	2 to 85 full scale voltage
Fixed hysteresis	12 full scale voltage
Level setting	±2 full scale voltage
Rating	40 V d.c., 100 mA maximum
Temperature range	
Operating	+5 to +60 °C
Storage	0 to +70 °C
Weight	110 g
External interface connector	8 way FCC68 / RJ45 socket

ATC-D, ATC-M gauge tubes

Pressure range	
ATC-D	50 to 5 x 10 ⁻² Torr 65 to 6.5 x 10 ⁻² mbar
ATC-M	1 to 1 x 10 ⁻³ Torr 1.3 to 1.3 x 10 ⁻³ mbar
Maximum overpressure	
ATC-D	10 bar absolute
ATC-M	3.4 bar absolute
Weight	55 g
Internal volume	
ATC-D	1 cm ³
ATC-M	8 cm ³

For more information, contact Edwards.

Ordering Information

Product Description	Order No.
ATC-E Electronics module	D35108000
ATC-D 1/8 inch NPT gauge tube	D35512000
ATC-M 1/8 inch NPT gauge tubes	D35513000
Accessories & Spares	Order No.
0.5M Active Gauge Cable	D40001005
100M Active Gauge Cable Assembly	D40001999
10M Active Gauge Cable	D40001100
15M Active Gauge Cable	D40001150
1M Active Gauge Cable	D40001010
25M Active Gauge Cable	D40001250
3M Active Gauge Cable	D40001030
50M Active Gauge Cable	D40001500
5M Active Gauge Cable	D40001050
NW10 Adapter Pipe 1/8NPT Female S/S	C10501072
Surge Protector Box	D40006000



The Edwards Active Strain Gauge (ASG) is a rugged, corrosion resistant diaphragm gauge which provides accurate, gas independent measurement from 2000 mbar to 1 mbar. It can be used as a stand-alone transducer allowing OEMs and system builders to develop low cost, flexible solutions to their vacuum instrumentation needs. Alternatively, it can be connected to the TIC Instrument Controller where it can be combined with many other sensor types to provide a complete vacuum instrument solution.

Note: ASG adaptor cable supplied separately. This cable must be used with TIC, AGC, ADC & ADD.

4 Features & Benefits

Page 152

- Drive electronics combined in the gauge head which simplifies system design and saves valuable rack space
- Wide range, regulated internal power supply which runs from standard d.c. power supplies of +13.5 to +36 V and is tolerant to voltage fluctuations
- Standard analogue output of 0 to 10 V d.c. which is easy to interface with a computer or PLC
- High accuracy and stability. Accuracy of ± 0.2 full scale and stability 0.2 full scale
- Corrosion resistant, rugged design where the only material exposed to vacuum is stainless steel 316

Dimensions

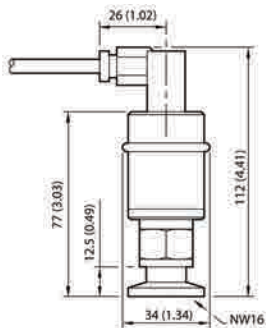

Applications

- Active strain gauges are an excellent choice where accurate, gas independent, measurement of pressures around atmosphere are required, making them ideal for applications such as load locks.
- It can be used as a stand-alone transducer allowing OEMs and system builders to develop low cost, flexible solutions to their vacuum instrumentation needs. Alternatively, it can be connected to the TIC Instrument Controller where it can be combined with many other sensor types to provide a complete vacuum instrument solution.

Performance Curves

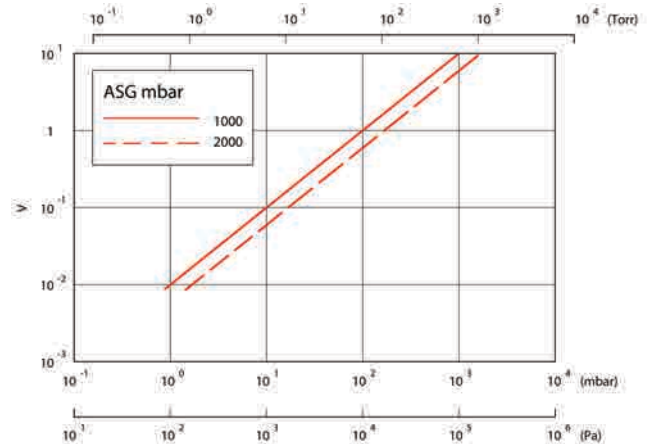

Technical Data

Full scale pressure range	1000 mbar
Accuracy	±0.2 full scale
Stability	±0.2 full scale
Temperature coefficient	±0.05 full scale per °C
Power supply	+13.5 to +36 V d.c.
Power consumption	0.4 W
Output signal	
Operating	0 to 10 V d.c. linear
Output impedance	>200 ohms
Minimum load	50 k ohms
Response speed	5 m/s
Adjustments	Set full scale and set zero
Temperature range	
Compensated	+10 to +50 °C
Operating	-20 to +90 °C
Materials exposed to vacuum	Stainless steel 316
Internal volume	1.25 cm ³
Weight	120g
Electrical connector	Miniature 4 pin Din
Vacuum fitting	1/8 Inch NPT
Standards	
Overall design	EN 61010-1
Electromagnetic compatibility	EN 61326 (Class B Emissions)
Enclosure rating	IP65

Ordering Information

Product Description	Order No.
ASG 1/8 Inch NPT, 1000 mbar	D35725000
ASG NW16, 1000 mbar	D35726000
ASG NW16, 2000 mbar	D35728000
ASG 1/8 Inch NPT, 2000 mbar	D35727000
ASG 1/8 Inch NPT, 1000 mbar, Certificated	D3572500C
ASG NW16, 1000 mbar, Certificated	D3572600C
ASG 1/8 Inch NPT, 2000 mbar, Certificated	D3572700C
ASG NW16, 2000 mbar, Certificated	D3572800C
Accessories & Spares	Order No.
0.5M Active Gauge Cable	D40001005
100M Active Gauge Cable Assembly	D40001999
10M Active Gauge Cable	D40001100
15M Active Gauge Cable	D40001150
1M Active Gauge Cable	D40001010
25M Active Gauge Cable	D40001250
3M Active Gauge Cable	D40001030
50M Active Gauge Cable	D40001500
5M Active Gauge Cable	D40001050
Adapter Cable AGC-ASG	D40003160
Surge Protector Box	D40006000

ASG2 Active Strain Gauge



The Edwards Active Strain Gauge (ASG2) is a rugged, corrosion resistant diaphragm gauge which provides accurate, gas independent measurement from 2000 mbar to 1 mbar and 1000 mbar to 1 mbar. It can be used as a stand-alone transducer allowing OEMs and system builders to develop low cost, flexible solutions to their vacuum instrumentation needs. Alternatively, it can be connected to the TIC Instrument Controller where it can be combined with many other sensor types to provide a complete vacuum instrument solution.

Note: ASG adaptor cable supplied separately. This cable must be used with TIC, AGC, ADC & ADD.

4 Features & Benefits

Page 154

- Drive electronics combined in the gauge head which simplifies system design and saves valuable rack space
- Wide range, regulated internal power supply which runs from standard d.c. power supplies of +12 to +32 V and is tolerant to voltage fluctuations
- Standard analogue output of 0 to 10 V d.c. which is easy to interface with a computer or PLC
- High accuracy and stability. Accuracy of ± 0.2 full scale and stability 0.1% full scale
- Corrosion resistant, rugged design where the material exposed to vacuum is stainless steel 316 L & Hastelloy C276

Dimensions

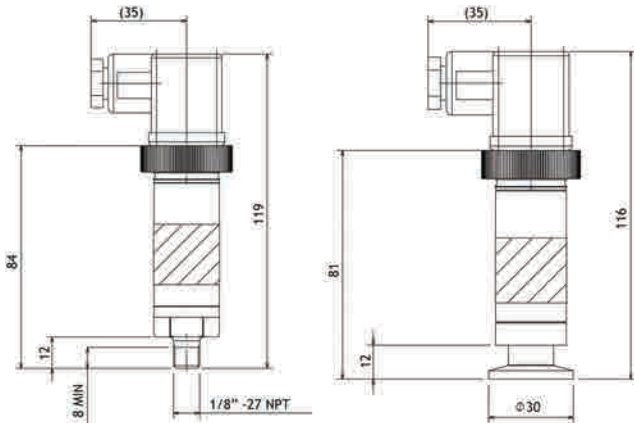

Applications

- Active strain gauges are an excellent choice where accurate, gas independent, measurement of pressures around atmosphere are required, making them ideal for applications such as load locks.
- It can be used as a stand-alone transducer allowing OEMs and system builders to develop low cost, flexible solutions to their vacuum instrumentation needs. Alternatively, it can be connected to the TIC Instrument Controller where it can be combined with many other sensor types to provide a complete vacuum instrument solution.

Performance Curves

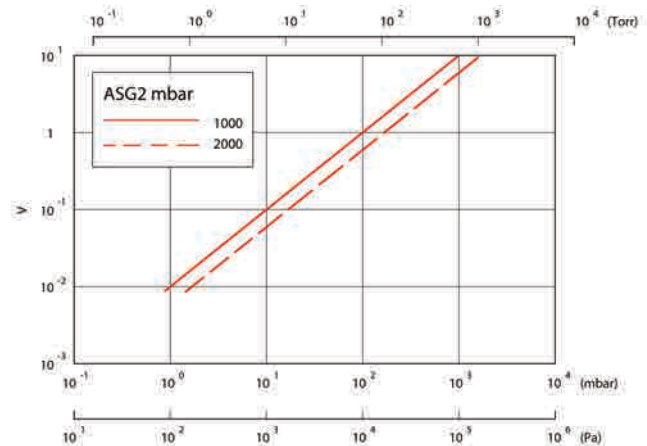

Technical Data

Full scale pressure range	1000 mbar, 2000 mbar
Accuracy	±0.2% full scale
Stability	±0.2% full scale
Temperature coefficient	±0.03% full scale per °C
Power supply	12 to 32 V d.c.
Power consumption	0.1 W
Output signal	
Operating	0 to 10 V d.c. linear
Output impedance	51 ohms
Minimum load	>10 k ohms
Adjustments	Set full scale and set zero
Temperature range	
Compensated	-10 to +50 °C
Operating	-40 to +80 °C
Materials exposed to vacuum	Stainless steel 316L, Hastelloy C276
Internal volume	2.78 cm ³
Weight	150g
Electrical connector	4 pin Din 43650 Form A
Vacuum fitting	1/8 Inch NPT, NW16
Standards	
Electromagnetic compatibility	EN 61326 -2-J for Transducers
Enclosure rating	IP65

Ordering Information

Product Description	Order No.
ASG2 1/8 Inch NPT, 1000 mbar	D35735000
ASG2 NW16, 1000 mbar	D35736000
ASG2 NW16, 2000 mbar	D35738000
ASG2 1/8 Inch NPT, 2000 mbar	D35737000
ASG2 1/8 Inch NPT, 1000 mbar, Certificated	D3573500C
ASG2 NW16, 1000 mbar, Certificated	D3573600C
ASG2 1/8 Inch NPT, 2000 mbar, Certificated	D3573700C
ASG2 NW16, 2000 mbar, Certificated	D3573800C
Accessories & Spares	Order No.
0.5M Active Gauge Cable	D40001005
100M Active Gauge Cable Assembly	D40001999
10M Active Gauge Cable	D40001100
15M Active Gauge Cable	D40001150
1M Active Gauge Cable	D40001010
25M Active Gauge Cable	D40001250
3M Active Gauge Cable	D40001030
50M Active Gauge Cable	D40001500
5M Active Gauge Cable	D40001050
Adapter Cable AGC-ASG	D40003160
Surge Protector Box	D40006000

AIM-X Active Inverted Magnetron Gauge



The Edwards Active Inverted Magnetron Gauges (AIM) combine the gauge-head and controller in one compact Active unit. These gauges have proved to be rugged and reliable in a wide range of applications ranging from scientific instruments to industrial processes.

This gauge features a linear output for easy integration with a computer or PLC.



4 Features & Benefits

Page 156

- Drive electronics combined in the gauge head which reduces the system cost and saves valuable rack space
- Low output impedance and integral Faraday shield provides high level of noise immunity and permits long cable runs (up to 100 m)
- Low magnetic field version - XL - for sensitive applications e.g. mass spectrometry and electron microscopy.
- Interchangeable body tube allows for rapid tube replacement without pre-calibration
- CSA, C/US approved

Dimensions

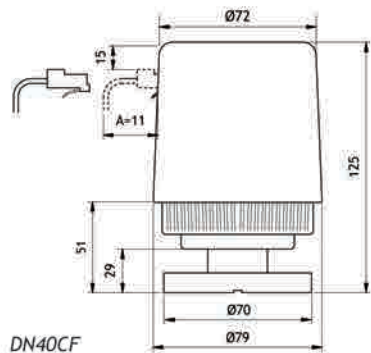
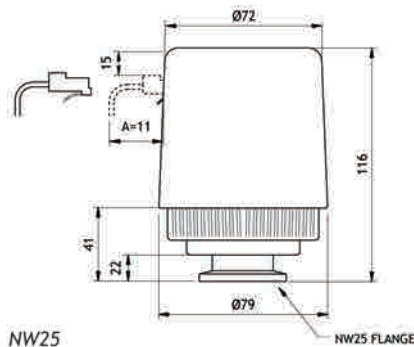

Applications

- All vacuum applications requiring rugged and reliable pressure indication in the range 1×10^{-2} to 1×10^{-9} mbar. Typical processes range from general vacuum through industrial coaters and furnaces to scientific instruments and semicon.

Performance Curves

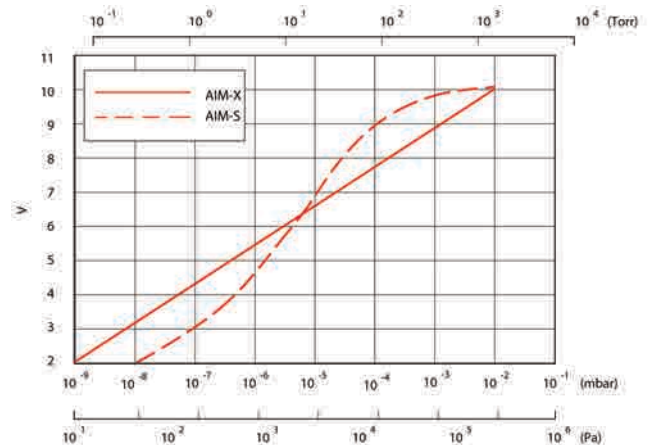

Technical Data

Pressure Range	
AIM-X	10^{-2} to 10^{-9} mbar
Accuracy*	Typically $\pm 30\%$
Maximum overpressure	10 bar absolute (145 psi)
Power supply	+13.5 to +36 V DC (max 1 V ripple)
Power consumption	2 W Maximum
Output signal	2 to 10 V DC
Set point	Open collector transistor
Maximum voltage	40V DC
Current	100 mA max
Temperature range	
Operating	+5 to +60°C
Storage	0 to +70°C
Materials exposed to vacuum	
NW25 versions	Stainless steel 304 & 306 & 347, fluoroelastomer, glass
Internal volume	26 cm ³
Weight	0.81 kg
External interface connector	8-way FCC68/RJ45 socket
Vacuum fitting	NW25
Standards	
Electromagnetic compatibility	EN 61326 (Class B Emissions)
Enclosure rating	IP40

*Accuracy is reduced at the limits of the measuring range

Ordering Information

Product Description	Order No.
AIM-X-NW25	D14642000
AIM-X-DN40CF	D14662000
AIM-X-NW25, Certificated	D1464200C
AIM-X-DN40CF, Certificated	D1466200C
AIM-XL-NW25	D14645000
AIM-XL-DN40CF	D14665000
AIM-XL-NW25, Certificated	D1464500C
AIM-XL-DN40CF, Certificated	D1466500C
Accessories & Spares	Order No.
0.5M Active Gauge Cable	D40001005
100M Active Gauge Cable Assembly	D40001999
10M Active Gauge Cable	D40001100
15M Active Gauge Cable	D40001150
1M Active Gauge Cable	D40001010
25M Active Gauge Cable	D40001250
3M Active Gauge Cable	D40001030
50M Active Gauge Cable	D40001500
5M Active Gauge Cable	D40001050
Aim Body Tube Assy - NW25	D14545801
Aim Body Tube Assy DN40CF	D14661801
AIM-X Elect & Mag Housing	D14642800
NW25 Centering Ring 3D Baffle Viton	D02110000
Spares Kit Aim Body Tube	D14545802
Spares Kit Aim Body Tube DN40CF	D14661802
Surge Protector Box	D40006000

WRG Active Wide Range Gauge



The Wide Range Gauge (WRG) family offers the capability of single port pressure measurement in the range atmosphere to 10^{-9} mbar with a linear output. Its a compact solution, halving the space and connectivity hardware requirement, which can be all important in many applications. The WRG has many novel features, including a new patented striker, pushbutton calibration and set point controls and comprehensive diagnostics. The WRG is a cost-effective vacuum management solution when used either with a Edwards controller or directly integrated into the system controls.

4 Features & Benefits

Page
158

- Microprocessor signal processing gives seamless transition between Pirani and magnetron outputs as well as linear output (log pressure scale)
- D-type version including cable strain relief and enhanced ingress protection - IP44
- Low magnetic field version (SL) available for sensitive applications e.g. mass spectrometry and electron microscopy
- Easily programmed set point covering entire measuring range
- Magnetron uses an advanced patented technique for highly reliable striking, even at high vacuum or in relatively contaminated conditions

Dimensions

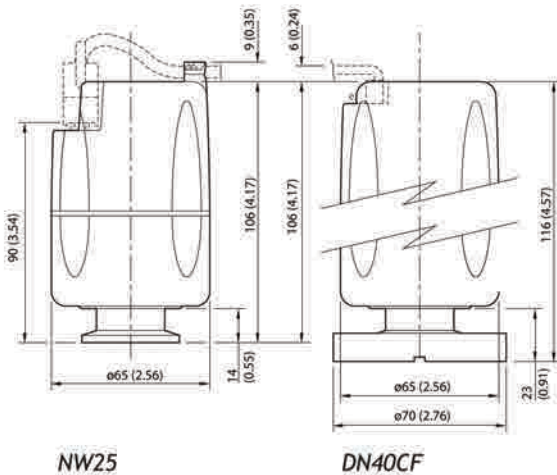

Applications

- Any vacuum system where there is a need to measure pressure over a wide range. The WRG with an AGD represents a very simple and cost effective means of achieving this.
- The linear output and equation make WRG's an attractive option for industrial OEM's where the gauge may be directly integrated into the process controller.
- The WRG is suitable for a wide range of HV and UHV applications, however if your process will spend a significant amount of time between 5×10^{-4} and 5×10^{-3} mbar then Edwards recommend using independent APG100 Pirani and AIM Penning gauges, as this will improve gauge reliability for your application.

Performance Curves

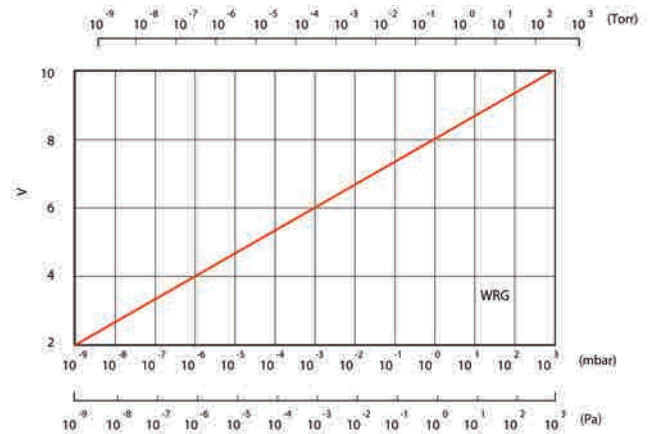

Technical Data

Pressure range	Atmosphere to 10^{-9} mbar/Torr
Accuracy *	Typically $\pm 15\%$ <100 mbar and $\pm 30\%$ < 10^{-3} mbar
Maximum over pressure	6 bar absolute (87 psia)
Power supply	+14.5 to +36 V d.c.
Power consumption	2 W maximum
Output signal	1.8 to 10.2 V d.c.
Adjustments	Atmosphere and setpoint
Set point	Open collector transistor
Maximum voltage	40 V d.c.
Current	100 mA maximum
Temperature range	
Operating	+5 to +60 °C
Storage	0 to +70 °C
Materials exposed to vacuum (Both NW and CF versions)	Stainless steel (AISI 304, 316, 321, 347), Fluoroelastomer, soda lime glass, Tungsten, trace of Nickel and Nickel Iron
Internal volume	26 cm ³
Weight	0.8 kg
External interface connector	8-way FCC68 / RJ45 Socket
Interface cables	Use range of active gauge cables
Standards	
Electromagnetic compatibility	EN 61326 Industrial Location, Class B emissions
Enclosure rating	IP40
Pin allocation **	
1. Power supply positive	5. Signal common
2. Power supply common	6. Set-point output
3. Gauge output	7. Atmosphere calibration
4. Gauge identification	8. Not connected

* Accuracy is reduced at the limits of the measuring range.

** Not shown on diagram

Ordering Information

Product Description	Order No.
WRG-S-NW25	D14701000
WRG-S-DN40CF	D14703000
WRG-S-NW25, Certificated	D1470100C
WRG-S-DN40CF, Certificated	D1470300C
WRG-D-NW25	D14702000
WRG-SL-NW25	D14711000
WRG-SL-NW25, Certificated	D1471100C
Accessories & Spares	Order No.
0.5M Active Gauge Cable	D40001005
100M Active Gauge Cable Assembly	D40001999
10M Active Gauge Cable	D40001100
15M Active Gauge Cable	D40001150
1M Active Gauge Cable	D40001010
25M Active Gauge Cable	D40001250
3M Active Gauge Cable	D40001030
50M Active Gauge Cable	D40001500
5M Active Gauge Cable	D40001050
NW25 Centering Ring 3D Baffle Viton	D02110000
Spares Kit WRG Electrode Assy	D14701802
Spares Kit WRG Full Body Tube	D14701804
Spares Kit WRG Pirani Tube	D14701803
Surge Protector Box	D40006000
WRG Body Tube Assy DN40CF	D14703801
WRG Body Tube Assy NW25	D14701801
WRG D Adapter Cable 9-Way D/Fcc68	D40003100
WRG-D Elect & Mag Housing NW25	D14702800
WRG-S Elect & Mag Housing NW25	D14701800
WRG-SL Elect & Mag Housing NW25	D14711800

AIGX Active Ion Gauge



A compact Active ion gauge with dual yttria coated iridium filaments, a wide measuring range from 6.6×10^{-2} to 6.6×10^{-10} mbar (5×10^{-2} to 5×10^{-10} Torr) and a 1 Volt/decade linear output.

The new AIGX gauge from Edwards incorporates all the benefits of the industry standard Active gauging concept, with integral electronics and replaceable tube. The gauge has a degas facility and includes features to protect and extend the life of the filaments. The AIGX benefits from extremely low emissions of charged particles, which makes it an excellent choice for processes where background noise is undesirable.

4 Features & Benefits

Page 160

- Full 8-decade measurement capability, to 6.6×10^{-10} mbar (5×10^{-10} Torr).
- Two versions available, each with three vacuum coupling variants:
- 'D' versions have a 9-pin 'D' connector and standard interface;
- Up to a thirty-fold reduction in charged particle process contamination compared to leading competitors.
- Automatic filament protection against switching on at atmosphere and running or degassing at high pressure.

Performance Curves

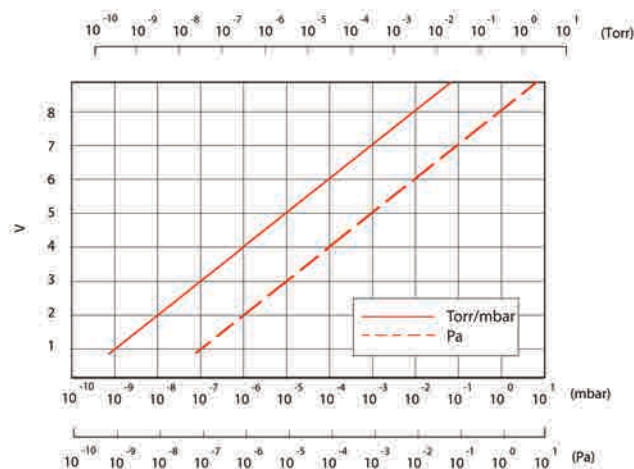

Dimensions

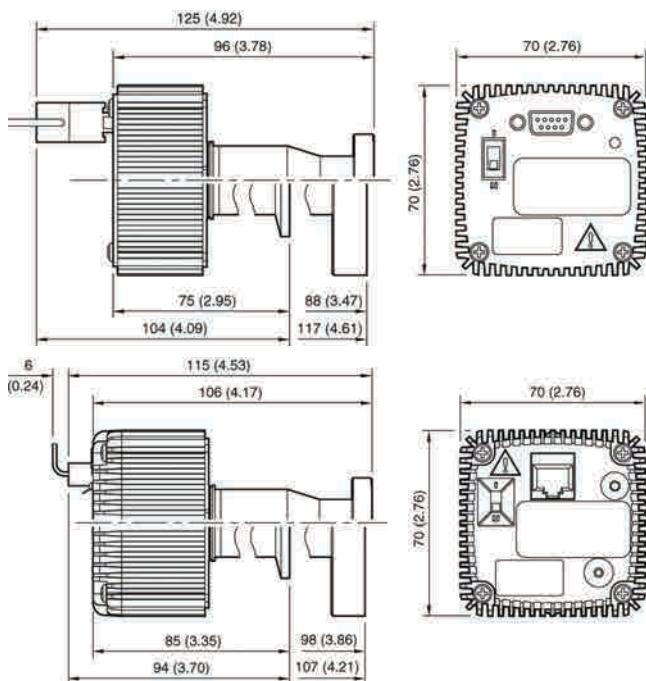

Technical Data

Pressure range	6.6×10^{-2} to 6.6×10^{-10} mbar (5×10^{-2} to 5×10^{-10} Torr)
Power supply	+14.5 to +30.0 V d.c.
Power consumption	Normal operation: 7W (Max), Degas: 14W (Max)
Output signal	Linear, 1 Volt / decade
Response time	1.33×10^{-8} mbar ($>10^{-8}$ Torr) ~100 ms 1.33×10^{-8} mbar ($<10^{-8}$ Torr) ~1-2 s
Maximum voltage	30 V d.c.
Maximum current	100 mA max
Temperature range	
Operating temperature	0 to +40 °C
Storage temperature	-30 to +70 °C

For more information, contact Edwards.

Ordering Information

Product Description	Order No.
AIGX-D-NW25	D04860000
AIGX-D-DN16CF	D04861000
AIGX-D-DN40CF	D04862000
AIGX-D-NW25, Certificated	D0486000C
AIGX-D-DN16CF, Certificated	D0486100C
AIGX-D-DN40CF, Certificated	D0486200C
AIGX-S-NW25, Certificated	D0485000C
AIGX-S-DN16CF, Certificated	D0485100C
AIGX-S-DN16CF	D04851000
AIGX-S-DN40CF	D04852000
AIGX-S-DN40CF, Certificated	D0485200C
AIGX-S-NW25	D04850000
Accessories & Spares	Order No.
0.5M Active Gauge Cable	D40001005
1M Active Gauge Cable	D40001010
3M Active Gauge Cable	D40001030
5M Active Gauge Cable	D40001050
10M Active Gauge Cable	D40001100
AIGX Fuses Spare Pk5	D04850805
AIGX Tube DN40CF	D04852801
AIGX Tube Spare DN16CF	D04851801
AIGX Tube Spare NW25	D04850801
AIGX-D Electronics Module SP	D04860800
AIGX-S Electronics Module SP	D04850800
DN16CF/1.33 Annealed Copper Gasket Pk 5	C10001270
DN16CF/1.33 Nut & Bolt & Washer M4 Pk 25	C10001630
DN40CF/2.75 Annealed Copper Gasket Pk 5	C10005270
DN40CF/2.75 Nut & Bolt & Washer M6 Pk 25	C10005630
NW25 Trapped O Ring Viton	C10514490

Model 1575 Pressure Display



The Model 1575 Pressure Display is a low cost, microprocessor based, digital display and set-point controller for the Barocel 600, 622 and 655 capacitance manometers. The Model 1575 incorporates power supply, digital display, four user-selectable set-points, along with analog outputs in a compact 1/8 DIN package.

4 Features & Benefits

Page
162

- Push button or remote zero adjustment
- Push button full scale calibration
- There are four user programmable solid-state, open collector set-points; two high and two low. The hysteresis band associated with each set-point can also be adjusted to meet system requirements.
- Easy to read LED display
- Optional RS232 output

Technical Data

Signal input	± 10 V d.c.
d.c. output	Transducer input signal
A/D resolution	± 25000 counts
Accuracy ¹	± 0.005% of reading ± 2 counts
Full scale temperature coefficient	20 ppm/ °C
Zero temperature coefficient	0.001 ppm/ °C
Zero suppression	± 100% of full scale
Transducer supply	±15 V d.c. at 250 mA (maximum)
Electrical supply (50 - 60 Hz)	
Standard	230 V ac ± 10%
Optional	115 V ac ± 10%
Set-points (4 open collector transistors)	
Voltage (maximum)	50 V
Current (maximum)	100 mA
Hysteresis (both set-points)	0 - 99 counts
Control status	LEDs indicate controls actuated
Operating temp range	+0 to +55 °C
Storage temp range	-40 to +85 °C
Warm-up time (at 25 °C)	30 minutes
Electronic safety	EN 61010-1
Electromagnetic compatibility	EN 61326 Industrial Location, Class A Emissions
List of compatible transducers	Barocel® 600, 655

Ordering Information

Product Description	Order No.
Model 1575, Analog Output, 115V	W60810000
Model 1575, Analog Output, 230V	W60820000
Model 1575, RS232 Output, 230V	W60820004
Model 1575, RS232 Output, 115V	W60810004
Accessories & Spares	Order No.
Cable 1800 To 600 Length 15'	W18997005
Cable 1800 To 655 Length 15'	W18992005
Cable 622 Barocel 1501C/1575	W18999005
Linecord 2M North Euro Plug	D40013030
Linecord 2M UK Plug	D40013025
Linecord 2m With US Plug	D40013120

CG16K dial gauge

Edwards CG16K capsule dial gauges are barometrically compensated with NW flange fittings. Designed to cover the range of 0 to 1040 mbar, these robust gauges provide accurate, repeatable performance even at low pressures making them equally suited for non-corrosive process plant or for laboratory applications. Fitting is simple: the gauges can be mounted direct or panel mounted using the kit supplied.



Features & Benefits

- Reading independent of gas type
- Accurate to $\pm 2\%$ of full scale
- Barometrically independent
- Pipeline or panel mounting
- Easy to read linear scale

Dimensions

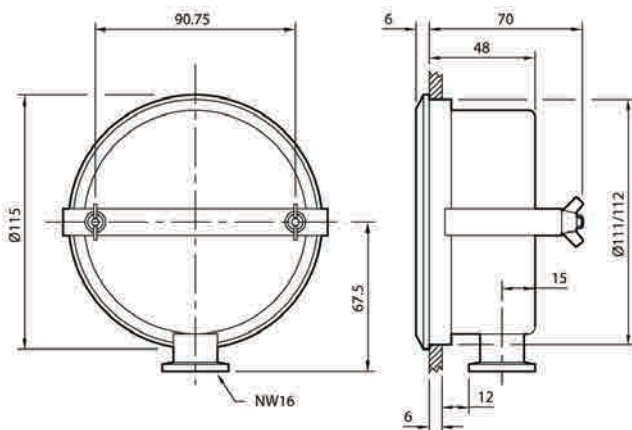

Applications

- Backfilling
- Portable equipment
- Degassing
- Refrigeration
- Flammable vapours

Ordering Information

Product Description	Order No.
CG16K, 0-1040 mbar	D35610000
CG16K, 0-125 mbar	D35611000
CG16K, 0-50 mbar	D35612000
CG16K, 0-25 mbar	D35613000
CG16K, 0-760 Torr	D35630000
CG16K, 0-100 Torr	D35631000
CG16K, 0-40 Torr	D35632000
CG16K, 0-20 Torr	D35633000
CG16K, 0-1040 mbar, Certificated	D3561000C
CG16K, 0-125 mbar, Certificated	D3561100C
CG16K, 0-50 mbar, Certificated	D3561200C
CG16K, 0-25 mbar, Certificated	D3561300C
CG16K, 0-760 Torr, Certificated	D3563000C
CG16K, 0-100 Torr, Certificated	D3563100C
CG16K, 0-40 Torr, Certificated	D3563200C
CG16K, 0-20 Torr, Certificated	D3563300C

Technical Data

Range	0-1040 mbar, 0-760 Torr 0-125 mbar, 0.100 Torr 0-50 mbar, 0-40 Torr 0-25 mbar, 0-20 Torr
Accuracy	$\pm 2\%$ of full scale deflection
Maximum applied pressure	
25 mbar version	1 bar absolute, 0 bar gauge
Other versions	2 bar absolute, 1 bar gauge
Weight	1 kg
Vacuum connection	NW16 Flange
Accessories supplied	Clamp and studs for panel mounting

IS16K Vacuum Interlock Switch



RoHS



The IS16K vacuum interlock switch is designed to safeguard the operator by ensuring that electrical circuits in the vacuum chamber do not remain energized when the system is let up to atmosphere.

Typical applications include interlocking of the HT cleaning or process circuits on thin film deposition and vacuum systems.

The IS16K is high vacuum compatible and corrosion resistant, with all wetted parts made from stainless steel. A high current rating allows direct switching of loads without additional relays or external power supplies.

4 Features & Benefits

- Single non-adjustable set-point, cannot be tampered with
- Positive break switch
- Rapid contact separation, prevents arcing
- Breaks circuit directly, no relays required
- Corrosion resistant materials exposed to vacuum

Dimensions

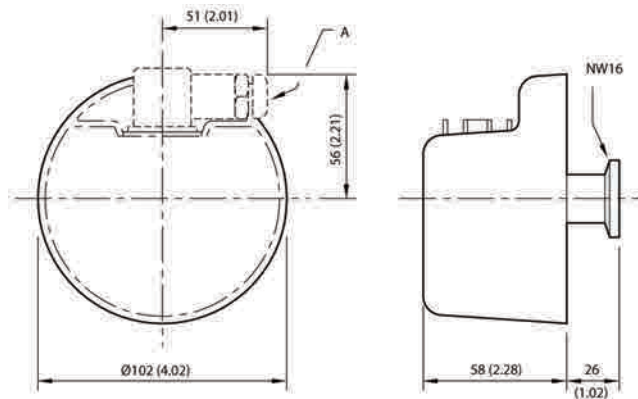

A Mating half shown fitted

Applications

- Furnaces
- Laboratories
- Tank units
- Packaging
- General purpose pumping units

Ordering Information

Product Description

IS16K Vacuum Interlock Switch

Order No.

D05914000

Technical Data

Fixed set-point	640 ±120 mbar*
Maximum switching differential	100 mbar
Maximum working pressure	1 bar gauge (2 bar absolute)
Electrical rating	10 A resistive, 5 A inductive at 250 V a.c.
Electrical connection plug	Type 283 mPm
Internal volume	7 cm ³
Materials in vacuum	Stainless steel
Leak rate	<1 x 10 ⁻⁹ mbar l s ⁻¹
Enclosure classification	IP52
Weight	0.7 kg
Vacuum connection	NW16
Accessories supplied	Mating electrical socket type 183 mPm

* Set point varies with barometric pressure

VS16K Adjustable Vacuum Switch



The VS16K is a general purpose vacuum switch with a user adjustable set-point and small switching differential. This diaphragm operated vacuum switch is high vacuum compatible and corrosion resistant with all wetted parts made from stainless steel. A high current rating allows direct switching of loads without additional relays or external power supplies.

This switch should not be used for safety critical applications. For many interlock applications the Edwards IS16K may be more suitable.



Features & Benefits

- Set-point range 30-1000 mbar
- User adjustable
- Reproducible
- Changeover contacts for normally open or normally closed operation
- Switch point independent of gas composition

Dimensions

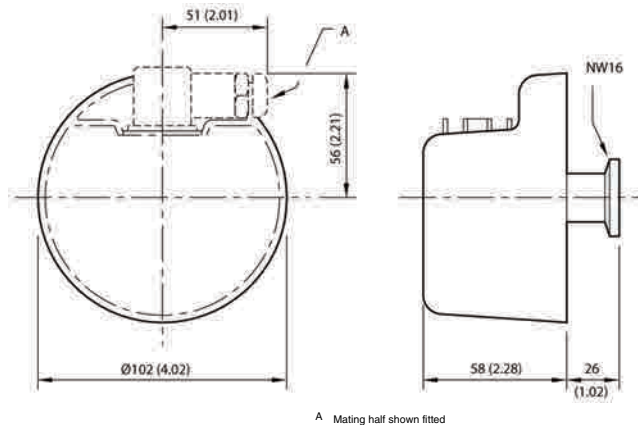

Applications

- Furnaces
- Laboratories
- Tank units
- Packaging
- General purpose pumping units

Ordering Information

Product Description	Order No.
VS16K Adjustable Vacuum Switch	D05915000

Technical Data

Range of adjustment	30 to 1000 mbar
Maximum switching differential	30 mbar
Maximum working pressure	1 bar gauge (2 bar absolute)
Electrical rating	10 A resistive, 5 A inductive at 250 V a.c.
Electrical connection plug	Type 283 mPm
Internal volume	7 cm ³
Materials in vacuum	Stainless steel
Leak rate	<1 x 10 ⁻⁹ mbar l s ⁻¹
Enclosure classification	IP52
Weight	0.7 kg
Vacuum connection	NW16
Accessories supplied	Mating electrical socket type 183 mPm

Set-point varies with barometric pressure

GasCheck G3



Introduced as an enhanced replacement for the popular GasCheck 3000, the Gascheck G3 incorporates a new backlit dot matrix LCD for improving viewing in poor lighting and leak rate indication by both flashing LED and sounder, for easier use in all environments. In addition the GasCheck G3 has a new tactile keyboard with fewer keys and improved temperature stability for better performance in uncontrolled areas.

4 Features & Benefits

Page
166

- Detect leaks with automatic and direct display of gas leak rate
- New, simple to interpret graphical icon display menu
- Choice of readings in cc/sec, mg/m³ or ppm
- Rapidly detects almost any known gas mixture – particularly sensitive to ammonia, argon, butane, helium
- Data logging facility – 10 data points with date and time stamp

Technical Data

Detector	Micro thermal conductivity sensor
Min detectable limits of some common gases:	
R134A	5.8x10 ⁻⁵ cc/sec
Helium	1.0x10 ⁻⁵ cc/sec
Argon	3.5x10 ⁻⁵ cc/sec
Carbon Dioxide	4.0x10 ⁻⁵ cc/sec
Sulphur Hexafluoride	2.2x10 ⁻⁵ cc/sec
Response/Recovery time	
Short probe	1s
Long probe	9s
Data logging	10 data points with date and time stamp
Batteries	4 off AA Alkaline or NiMH
Operating temp range	0 to 50 °C
Storage temp range	-25 to 70 °C
Length with 110 mm, short probe	390 mm
Length with 300 mm, long probe	580 mm
Storage Case	420 x 320 x 97 mm
Unpacked weight	0.5 kg
Packed weight	1.6 kg
Electrical noise immunity	EN61326, class B emissions

Applications

- Quality assurance testing on manufactured component seals
- Laboratory applications, such as the detection of leaks from gas chromatographs, from mass spectrometers, from gas cylinders and fittings
- Industrial applications, such as the detection of leaks from gas installations, in cylinder receiving rooms, from pipeline assemblies, the detection of leaks from stored gases and the detection of vapours released from stored chemicals
- Medical applications, such as the detection of leaks from gas bottles and pipelines and leak testing of membrane materials, glove boxes and so forth
- Pneumatic applications, such as leak testing of pipeline joints, gaskets and so forth

Ordering Information

Product Description	Order No.
GasCheck G3	D14132000
Accessories & Spares	Order No.
B Series Long Probe	D14128802
Gas Check Battery Holder	D14130802
Gas Check Nozzle	D14130800
Short Probe For B Series For Gas Check	D14128801



Speedivalves	169
Ball Valves	171
PVMK Manual Operation Isolation Valves	173
PVPK Pneumatic Operation Isolation Valves	175
PVEK Solenoid Operation Isolation Valves	179
Backing/Roughing Valves	187
Soft-Start Valves	189
BGV Stainless Steel Gate Valves	191
GV Manual and Pneumatic Gate Valves	195
Butterfly Valves	197
Air Admit and Needle Valves	199
Electro-Pneumatic Control Valves	202

Valves for Vacuum Systems



Complete Range

Whatever the application, Edwards has the right solution to meet your process requirements. Well known for its innovation in pump design, Edwards applies the same energy and commitment to its valves. The result is an extensive range of valves, with a choice of actuation methods, materials and size. Materials of construction have been uncompromisingly selected for performance in high vacuum.

Confidence in Edwards valves begins early in the design process. We use techniques such as Finite Element Analysis to optimise the design of the valve. An arduous testing program in our environmental testing laboratory prior to release to production ensures that every valve we supply will meet the needs of your application. Once in production, all valves are subject to stringent quality control and are individually tested with a helium mass spectrometer leak detector.

Bellows sealed pipeline valves are manufactured with 100% grease free O-rings exposed to vacuum delivering unrivalled low contamination levels.

Selection Guide

When you design a vacuum system, your choice of valves will be determined by the need for certain operating parameters. When you choose a valve for your vacuum system, consider all of the parameters listed in the left hand column of the table as described below.

Actuation The choice is manual, solenoid or pneumatic, which will be determined by your system design and what facilities are available to the machine.

Dirty System Tolerance Vacuum valves have a differing ability to remain leak tight in "dirty" vacuum systems. If your system generates or contains dust or other particulates, choose a valve with a high tolerance.

Size Choose a valve which complements the size of your vacuum pipeline. To maintain high pumping speeds and throughputs, do not reduce the size of your pipeline to accommodate a smaller valve.

Pressure Range Both the maximum and minimum pressure rating are important, particularly if the vacuum system is occasionally pressurized to above atmospheric pressure.

Port Configuration Depending on the location of the valve, you may need either an in-line or a right angle valve.

Life The mean time to failure is important for solenoid and pneumatic valves in rapid cycle duties, or where you have extended maintenance intervals.

Position Indication You may need local or remote indication of valve position as part of your control system.

Closure Speed Use either a solenoid valve or pneumatic valve if you must have rapid valve closure.

Corrosion Resistance Valves are available in stainless steel for those applications that process corrosive gases.

Edwards SP Speedivalves are diaphragm sealed in-line, isolation valves. The construction consists essentially of a flexible elastomeric diaphragm which is sealed onto a lightly polished seat by a screw thread mechanism. The mechanism is isolated from the system by the diaphragm resulting in an extremely rugged and 'dirty' system tolerant valve.

The valve terminates in NW flanges and can be pipeline supported or panel mounted. (SP40K is pipeline supported only).



Features & Benefits

- Easy to operate with visual indication of valve open (SP10K to SP25K)
- Leak tight to better than 10^{-6} mbar ls⁻¹ / 8×10^{-7} Torr ls⁻¹
- Diaphragm completely isolates mechanism from vacuum system
- Extremely rugged and 'dirty' system tolerant
- Will withstand 9 bar overpressure (SP10K to SP40K, with Co-Seal)

Dimensions

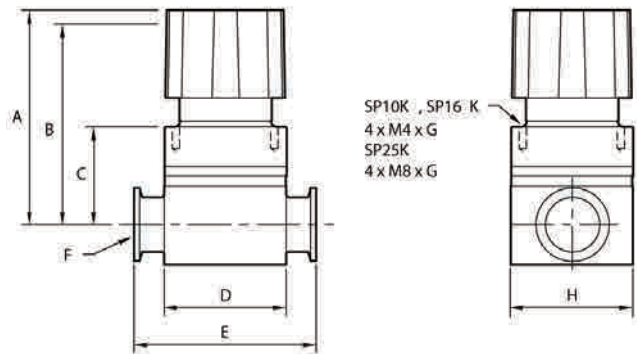

Model	A		C	D	E	F	G	H
	Open	Closed						
SP10K	71	64	33.5	42	60	NW10	8	43
SP16K	71	64	33.5	42	80	NW16	8	43
SP25K	123	111	51	67	100	NW25	12	72
SP40K	130	-	-	105	130	NW40	-	96

Technical Data

Construction materials	
Body	Aluminium alloy to BS1490
Hand wheel and bonnet	Glass reinforced plastics
Diaphragms	Nitrile or Fluoroelastomer
Leak rate (1 bar / 14.5 psi differential)	
Valve (overall and across seat)	10^{-6} mbar ls ⁻¹ 8×10^{-7} Torr ls ⁻¹
Coupling	10^{-7} mbar ls ⁻¹ 8×10^{-8} Torr ls ⁻¹
Molecular conductance	
SP10K, SP16K	1.7 ls ⁻¹
SP25K	9.0 ls ⁻¹
SP40K	23.3 ls ⁻¹
Pressure rating using Co-Seal	9 bar / 131 psi
Ambient operating range	0 to 40 °C
Ambient storage range	-10 to 40 °C
Panel thickness	3 mm / 0.117 in maximum
Weight	
SP10K	230 g / 8.1 oz
SP16K	240 g / 8.4 oz
SP25K	760 g / 26.6 oz
SP40K	2300 g / 80.5 oz
Baking temperature	60 °C

Ordering Information

Product Description	Order No.
SP10K, Nitrile Diaphragm	C33105000
SP10K, Fluoroelastomer Diaphragm	C33155000
SP16K, Nitrile Diaphragm	C33205000
SP16K, Fluoroelastomer Diaphragm	C33255000
SP25K, Nitrile Diaphragm	C33305000
SP25K, Fluoroelastomer Diaphragm	C33355000
SP40K, Nitrile Diaphragm	C33405000
SP40K, Fluoroelastomer Diaphragm	C33455000
Accessories & Spares	Order No.
Fluoroelastomer Diaphragm for SP10/16	C33155800
Fluoroelastomer Diaphragm for SP25	C33355800
Fluoroelastomer Diaphragm for SP40	C33455800
Nitrile Diaphragm for SP10/16	C33105800
Nitrile Diaphragm for SP25	C33305800
Nitrile Diaphragm for SP40	C33405800

IBV series vacuum ball valves

Ball valves are popular in applications where fast action and full bore pumping are needed. The Edwards IBV series valves combine these practical everyday features plus ease of use and economy in a high specification design. Manufactured in 316L stainless steel with PTFE seats they deliver robust performance in a wide variety of vacuum duties.



Features & Benefits

- Low capital cost
- Convenient NW16, 25, 40, 50 sizes
- Optional BSP threaded versions
- Easy to use manual operation
- High conductance full bore pumping

Dimensions

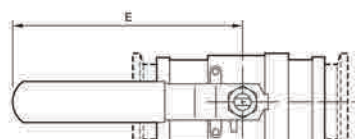
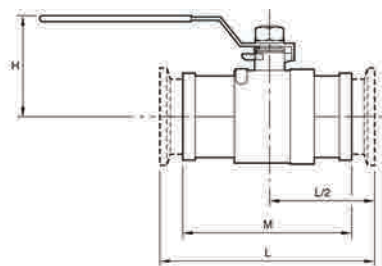

MODEL	E	H	L	M	FLANGE
IBV16MKS	120	56	92.5	-	NW10/16
IBV16MS	120	56	-	59.7	½" BSP
IBV25MKS	148	70	118.5	-	NW25
IBV25MS	148	70	-	82.5	1" BSP
IBV40MKS	164	84	166.5	-	NW40
IBV40MS	164	84	-	111	1½" BSP
IBV50MKS	164	94	175.5	-	NW50
IBV50MS	164	94	-	125	2" BSP

Technical Data

Construction materials	
Body	AISI 316L stainless steel
Ball	AISI 316L stainless steel
Cups	PTFE
Leak rate	1×10^{-6} mbar ls ⁻¹
	8×10^{-7} Torr ls ⁻¹
Molecular conductance	
IBV16MKS	5.3 ls^{-1}
IBV25MKS	15.9 ls^{-1}
IBV40MKS	46.5 ls^{-1}
IBV50MKS	86.0 ls^{-1}
Pressure rating (bar absolute) using NW Co-Seal	7 bar / 102 psi
Ambient operating temp range	5 to 65 °C
Reliability MTTF	30000 cycles
Weight (g/lbs)	
IBV16MKS (MS)	1200 / 2.6 (750 / 1.7)
IBV25MKS (MS)	1750 / 3.9 (1500 / 3.3)
IBV40MKS (MS)	3100 / 6.8 (2600 / 5.7)
IBV50MKS (MS)	4300 / 9.4 (3600 / 7.9)

Ordering Information

Product Description	Order No.
IBV16MKS Ball Valve NW16	C36000100
IBV16MS Ball Valve 1/2" BSP	C36000110
IBV25MKS Ball Valve NW25	C36000200
IBV25MS Ball Valve 1" BSP	C36000210
IBV40MKS Ball Valve NW40	C36000300
IBV40MS Ball Valve 1.1/2" BSP	C36000310
IBV50MKS Ball Valve NW50	C36000400
IBV50MS Ball Valve 2" BSP	C36000410

PVMK Manual Operation Right Angle Isolation Valves



The PVMK is a quick acting, bellows sealed, right-angled lever operated valve and is available with either an Aluminium or stainless steel body. The lever, connected to a self-lubricating plastic cam-piston, actuates the valve stem and valve plate through PTFE bearings. The valve plate 'O' ring groove is vented to prevent gas bursts. The valves are designed to operate down to 10^{-9} mbar / 8×10^{-10} Torr and up to a pressure of 2100 mbar / 1575 Torr (30 psi).



Technical Data

Construction material		
Body	HE30TF grade aluminium	
Bellows	AISI 316L stainless steel	
'O' ring	Fluoroelastomer	
Leak rate	$< 10^{-9}$ mbar ls ⁻¹	
	$< 7.5 \times 10^{-10}$ Torr ls ⁻¹	
Operating pressure range	10^{-9} - 2100 mbar	
	8×10^{-10} - 1575 Torr (30 psi)	
Molecular conductance		
PV10MK	3 ls ⁻¹	
PV16MK	4 ls ⁻¹	
PV25MK	10 ls ⁻¹	
PV40MK	38 ls ⁻¹	
PV50MK	50 ls ⁻¹	
Maximum baking temperature	100 °C	
Reliability (MTTF)	100000 operations	
Weight	Aluminium	Stainless Steel
PV10MK	170 g / 6 oz	-
PV16MK	180 g / 6.3 oz	500 g / 17.5 oz
PV25MK	490 g / 17.1 oz	1050 g / 36.8 oz
PV40MK	1400 g / 49 oz	3300 g / 116 oz
PV50MK	-	3800 g / 133 oz

Ordering Information

Product Description	Order No.
PV16MKA Right Angle, Aluminum, NW16	C31205000
PV16MKS Right Angle, Stainless Steel, NW16	C31215000
PV25MKA Right Angle, Aluminum, NW25	C31305000
PV25MKS Right Angle, Stainless Steel, NW25	C31315000
PV40MKA Right Angle, Aluminum, NW40	C31405000
PV40MKS Right Angle, Stainless Steel, NW40	C31415000
PV50MKS Right Angle, Stainless Steel, NW50	C31515000
PV10MKA Right Angle, Aluminum, NW10	C31105000
Accessories & Spares	Order No.
PV10/16MK O-Ring Kit	C41101800
PV25MK O-Ring kit	C41301810
PV40MK O-Ring kit	C41401800
PV50MK O-Ring kit	C41501800
PV10/16MK Major overhaul kit	C31105826
PV25MK Major overhaul kit	C31305826
PV40MK Major Overhaul kit	C31405826
PV50MK Major overhaul kit	C31515826
Valve Body PV10KA	C41101816
Valve body PV16KA	C41201816
Valve Body PV16KS	C41602801
Valve Body PV25KA	C41301816
Valve Body PV25KS	C41622801
Valve Body PV40KS	C41642801
Valve Body PV50KS	C41662801

Dimensions

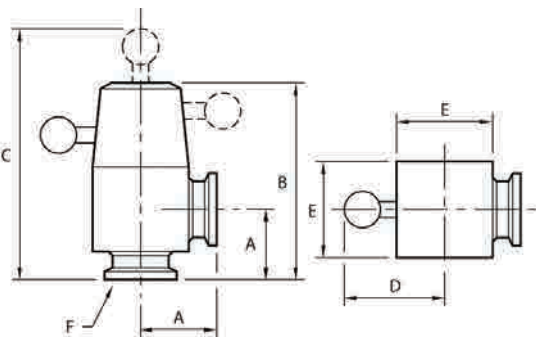

	A	B	C	D	E	F
PV10MK	30	76.5	105	38	38	NW10
PV16MK	40	85.6	114	38	38	NW16
PV25MK	50	120	149	51	51	NW25
PV40MK	65	169	222	86	77	NW40
PV50MK	70	186	239	86	89	NW50

IPVMK Manual Operation In-line Isolation Valves



The IPVMK is a quick acting, bellows sealed, right-angled lever operated valve and is available with either an Aluminium or stainless steel body. The lever, connected to a self-lubricating plastic cam-piston, actuates the valve stem and valve plate through PTFE bearings. The valve plate O-ring groove is vented to prevent gas bursts. The valves are designed to operate down to 10^{-9} mbar / 8×10^{-10} Torr and up to a pressure of 2100 mbar / 1575 Torr (30 psi).

Technical Data

Construction material		
Body	HE30TF grade aluminium or AISI304 grade stainless steel	
Bellows	AISI 316L stainless steel	
O-ring	Fluoroelastomer	
Leak rate	$< 10^{-9}$ mbar ls ⁻¹ $< 7.5 \times 10^{-10}$ Torr ls ⁻¹	
Operating pressure range	10^{-9} - 2100 mbar 8×10^{-10} - 1575 Torr (30 psi)	
Molecular conductance		
IPV16MK	2 ls ⁻¹	
IPV25MK	6 ls ⁻¹	
IPV40MK	22 ls ⁻¹	
Maximum baking temperature	100 °C	
Reliability (MTTF)	100000 operations	
Weight	Aluminium	Stainless Steel
IPV16MK	180g / 6.3oz	500g / 17.5oz
IPV25MK	490g / 17.1oz	1050g / 36.8oz
IPV40MK	1400g / 49oz	3300g / 116oz

Ordering Information

Product Description	Order No.
IPV16MKA, Aluminium, NW16	C41218000
IPV16MKS, Stainless Steel, NW16	C41219000
IPV25MKA, Aluminium, NW25	C41321000
IPV25MKS, Stainless Steel, NW25	C41322000
IPV40MKS, Stainless Steel, NW40	C41421000
IPV40MKA, Aluminium, NW40	C41420000
Accessories & Spares	Order No.
PV10/16MK O-Ring Kit	C41101800
PV25MK O-Ring kit	C41301810
PV40MK O-Ring kit	C41401800
PV10/16MK Major overhaul kit	C31105826
PV25MK Major overhaul kit	C31305826
PV40MK Major Overhaul kit	C31405826
Valve body IPV16KA	C41201802
Valve Body IPV16KS	C41602811
Valve Body IPV25KA	C41621802
Valve Body IPV25KS	C41622811
Valve Body IPV40KA	C41641802
Valve Body IPV40KS	C41642811

Dimensions

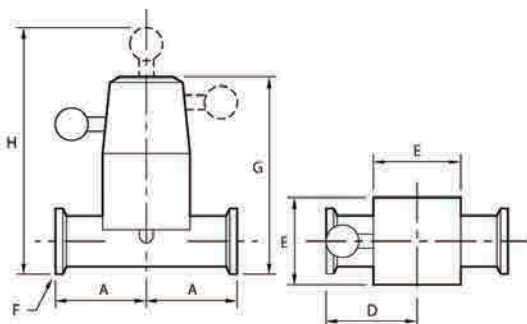

	A	B	C	D	E	F	G	H
IPV10MK	30	76.5	105	38	38	NW10	-	-
IPV16MK	40	85.6	114	38	38	NW16	70	99
IPV25MK	50	120	149	51	51	NW25	112	141
IPV40MK	65	169	222	86	77	NW40	155	208
IPV50MK	70	186	239	86	89	NW50	-	-

PVPK Pneumatic Operation Right Angle Isolation Valve



The range of single acting cylinder, spring return pipeline valves is designed for high speed actuation from standard pneumatic lines, and are offered in sizes NW10, 16, 25, 40 and 50. They are available with aluminium or stainless steel bodies with either O-ring (shaft seal Aluminium only) or bellows seal.

The valves are designed for long life duties, with a MTTF of 5000000 cycles for both bellows and 'O' ring sealed versions providing long intervals between services.



Features & Benefits

- Improved lifetime, mean-time-to-failure now 5000000 cycles
- Electrical and visual indication of valve status
- Fast acting - 20 ms to close (PV16)
- Available in aluminum or stainless steel
- Choice of bellows or 'O' ring shaft sealing with aluminum bodies

Dimensions

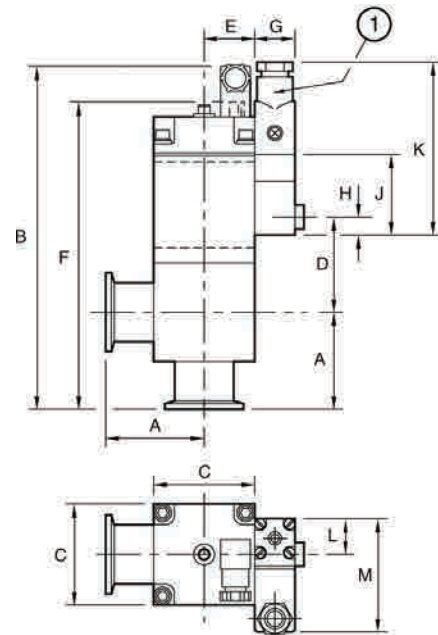

	A	B	C	D	E	F	G	H	J	K	L	M
PV10PK	30	139.5	38	41	25	122	20	10	40	88	19	59
PV16PK	40	149.5	38	41	25	132	20	10	40	88	19	59
PV25PK	50	171.3	50.8	47.6	28	153.7	20	10	40	88	19	59
PV40PK	65	200.6	76.2	57.8	41	183	20	10	40	88	19	59
PV50PK	70	218	92	70	41	200	20	10	40	88	19	59

1 Optional control valve

Technical Data

Valve actuation type	Single acting, pneumatically opened, spring closed
Pressure range	1 x 10 ⁻⁹ to 2100 mbar 8 x 10 ⁻¹⁰ to 1575 Torr

Max pressure differential

Opening	1000 mbar / 750 Torr
Closing	2100 mbar / 1575 Torr
Leak rate	< 1 x 10 ⁻⁹ mbar ls ⁻¹ < 8 x 10 ⁻¹⁰ Torr ls ⁻¹

Pneumatic connector	Rp 1/8 (1/8 inch BSP) *
Pneumatic operating pressure	2.8 to 4.2 bar / 41 to 61 psi
Electrical indicator	Single microswitch ‡
Microswitch electrical rating	24 V, 1.5 A a.c. or d.c.
Max cycle frequency	900 h ⁻¹
Bellows reliability, MTTF	5000000 cycles
Ambient operating temp	5 - 100 °C
Maximum baking temp	100 °C

Construction materials

PVPKA	HE30TF aluminium
PVPKS	AISI304 stainless steel
Bellows	AISI316L stainless steel
O-ring	Fluoroelastomer

Molecular conductance (ls⁻¹) Right angled

PV10PK	3
PV16PK	4
PV25PK	10
PV40PK	40
PV50PK	50

‡ Twin microswitch versions are available on request.

	Time to open (ms)*	Time to close (ms)*
PV10/16PK	60	20
PV25PK	15	41
PV40PK	50	155
PV50PK	50	155
Weight	Aluminium	Stainless Steel
PV16PK	310g / 10.9oz	520g / 18.2oz
PV25PK	610g / 21.4oz	980g / 34.3oz
PV40PK	1500g / 52.5oz	2300g / 80.5oz
PV50PK	2000g / 70.5oz	4000g / 140oz

* With optional control valve fitted

Ordering Information

Product Description	Order No.
PV10PKAO, O-ring sealed, aluminium	C41113000
PV10PKA, bellows sealed, aluminium	C41111000
PV16PKAO, O-ring sealed, aluminium	C41213000
PV16PKA, bellows sealed, aluminium	C41211000
PV16PKS, bellows sealed, stainless steel	C41215000
PV25PKAO, O-ring sealed, aluminium	C41313000
PV25PKA, bellows sealed, aluminium	C41311000
PV25PKS, bellows sealed, stainless steel	C41315000
PV40PKAO, O-ring sealed, aluminium	C41413000
PV40PKA, bellows sealed, aluminium	C41411000
PV40PKS, bellows sealed, stainless steel	C41415000
PV50PKA, bellows sealed, aluminium	C41510000
PV50PKS, bellows sealed, stainless steel	C41515000
Accessories & Spares	Order No.
Spares Kit Valve Seals PVPK10/16	C41111800
Spares Kit Valve Seals PV25PK	C41311800
Spares Kit Valve Seals PV40PK	C41411800
PV50MK O-Ring kit	C41501800
Top Cap Assembly PV10/16P	C41111821
Top Cap Assy PV25P	C41311821
Top Cap Assembly PV40P	C41411821
PV10PO Ring Actuator Assembly	C41113035
Bellows Actuator Assy PV10P	C41111035
PV25PO Ring Actuator Assembly	C41313035
Bellows Actuator Assy PV25P	C41311035
O Ring Actuator Assy PV40P	C41413035
Bellows Actuator Assy PV240P	C41411035
Bellows Actuator Assy PV50P	C41515035
Valve Body PV10KA	C41101816
Valve body PV16KA	C41201816
Valve Body PV16KS	C41602801
Valve Body PV25KA	C41301816
Valve Body PV25KS	C41622801
Valve Body PV40KA	C41401816
Valve Body PV40KS	C41642801
Valve body PV50KA	C41662816
Valve Body PV50KS	C41662801
3 Port Electropneumatic Control Valve 24V d.c.	H06200124
3 Port Electropneumatic Control Valve 24V a.c.	H06200125
3 Port Electropneumatic Control Valve 110V a.c.	H06200126
3 Port Electropneumatic Control Valve 230V a.c.	H06200138

IPVPK Pneumatic Operation In-Line Isolation valves



The Edwards range of in-line single acting cylinder, spring return pipeline valves are designed for high speed actuation from standard pneumatic lines, and are offered in sizes NW16, 25, 40 and 50. They are available with aluminium or stainless steel bodies with either O-ring (shaft seal, aluminium only) or bellows sealed.

The valves are designed for long life duties, with a MTTF of 5000000 cycles for both bellows and 'O' ring sealed versions providing long intervals between services.



Features & Benefits

- Improved lifetime, mean-time-to-failure now 5000000 cycles
- Electrical and visual indication of valve status
- Fast acting - 20 ms to close (PV16)
- Available in aluminum or stainless steel
- Choice of bellows or 'O' ring shaft sealing with aluminum bodies

Dimensions

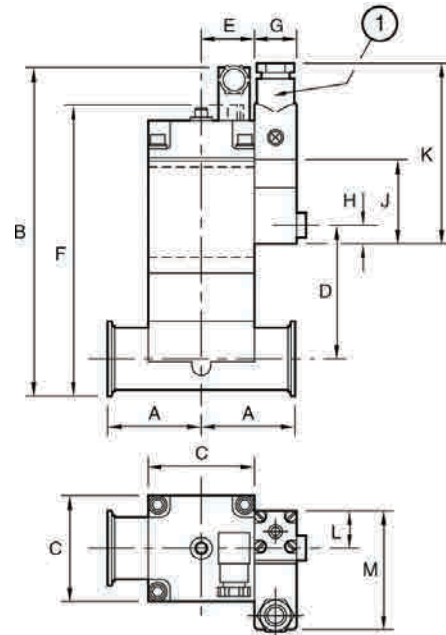

	A	B	C	D	E	F	G	H	J	K	L	M
PV16PK	40	132.9	38	49.4	22.9	115.4	20	10	40	88	19	59
PV25PK	50	161.9	50.8	68.2	25.8	144.3	20	10	40	88	19	59
PV40PK	65	192.2	76.2	86.9	38.2	174.6	20	10	40	88	19	59
PV50PK	70	216.9	92	101.6	38.8	199.3	20	10	40	88	19	59

1 Optional control valve

Technical Data

Valve actuation type	Single acting, pneumatically opened, spring closed			
Pressure range	1 x 10 ⁻⁹ to 2100 mbar 8 x 10 ⁻¹⁰ to 1575 Torr			
Maximum pressure differential	Opening 1000 mbar / 750 Torr Closing 2100 mbar / 1575 Torr			
Leak rate	< 1 x 10 ⁻⁹ mbar ls ⁻¹ < 8 x 10 ⁻¹⁰ Torr ls ⁻¹			
Pneumatic connector	Rp 1/8 (1/8 inch BSP) *			
Recommended pneumatic operating pressure	2.8 to 4.2 bar / 41 to 61 psi			
Electrical indicator	Single micro switch ‡			
Micro switch electrical rating	24 V, 1.5 A a.c. or d.c.			
Max cycle frequency	900 h ⁻¹			
Bellows reliability, MTTF	5000000 cycles			
Ambient operating temperature	5 - 100 °C			
Maximum baking temperature	100 °C			
Construction materials	IPVPKA HE30TF aluminium IPVPKS AISI304 stainless steel Bellows AISI316L stainless steel O-ring Fluoroelastomer			

‡ Twin micro switch versions are available on request.

	IPV16PK	IPV25PK	IPV40PK	IPV50PK
Molecular conductance (ls ⁻¹)	2	6	18	30
Time to open (ms)*	60	15	50	50
Time to close (ms)*	20	41	155	155
Weight				
Aluminium	310 / 10.9	610 / 21.4	1500 / 52.5	-
Stainless Steel	520 / 18.2	980 / 34.3	2300 / 80.5	4000 / 140

- With optional control valve fitted

Ordering Information

Product Description	Order No.
IPV16PKAO, O-ring sealed, aluminium	C41603000
IPV16PKA, bellows sealed, aluminium	C41601000
IPV16PKS, bellows sealed, stainless steel	C41602000
IPV25PKAO, O-ring sealed, aluminium	C41623000
IPV25PKA, bellows sealed, aluminium	C41621000
IPV25PKS, bellows sealed, stainless steel	C41622000
IPV40PKAO, O-ring sealed, aluminium	C41643000
IPV40PKA, bellows sealed, aluminium	C41641000
IPV40PKS, bellows sealed, stainless steel	C41642000
IPV50PKS, bellows sealed, stainless steel	C41662000
Accessories & Spares	Order No.
Spares Kit Valve Seals PVPK10/16	C41111800
Spares Kit Valve Seals PV25PK	C41311800
Spares Kit Valve Seals PV40PK	C41411800
PV50MK O-Ring kit	C41501800
Top Cap Assembly PV10/16P	C41111821
Top Cap Assy PV25P	C41311821
Top Cap Assembly PV40P	C41411821
PV10PO Ring Actuator Assembly	C41113035
Bellows Actuator Assy PV10P	C41111035
PV25PO Ring Actuator Assembly	C41313035
Bellows Actuator Assy PV25P	C41311035
O Ring Actuator Assy PV40P	C41413035
Bellows Actuator Assy PV240P	C41411035
Bellows Actuator Assy PV50P	C41515035
Valve body IPV16PKA	C41601802
Valve Body IPV16KS	C41602811
Valve Body IPV25KA	C41621802
Valve Body IPV25KS	C41622811
Valve Body IPV40KA	C41641802
Valve Body IPV40KS	C41642811
Valve body IPV50KS	C41662811
3 Port Electropneumatic Control Valve 24V d.c.	H06200124
3 Port Electropneumatic Control Valve 24V a.c.	H06200125
3 Port Electropneumatic Control Valve 110V a.c.	H06200126
3 Port Electropneumatic Control Valve 230V a.c.	H06200138

PVEK Solenoid Operation Right Angle Isolation valves



The Edwards PVEK series valves are compact, light-weight electromagnetic vacuum valves suitable for use in vacuum pipeline systems down to 1×10^{-9} mbar. A double wound coil combined with an electronic switching circuit ensures low energy consumption, low operating temperatures and extended operating life.

Bellows sealed, the PVEK solenoid operated right angle valves are available with either aluminum (A) or stainless steel (S) bodies, with an overall MTTF of up to 500,000 cycles.



Features & Benefits

- Transient high power for opening - electronically switched
- Low energy consumption in the 'hold open' position
- Enclosure rating to IP55
- Grease free vacuum
- MTTF up to 500000 cycles

Dimensions

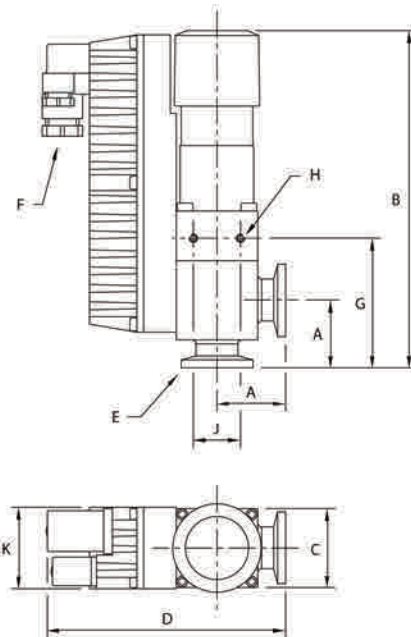

F Connectors for electrical supply and reed switch cables.

(mm)	A	B	C	D	E	G	H	J	K
PV10EK	30	150	38	116	NW10	59	M4 x 7	20	41
PV16EK	40	160	38	126	NW16	69	M4 x 7	20	41
PV25EK	50	182	51	142	NW25	82	M4 x 7	20	41
PV40EK	65	230	76	170	NW40	110	M6 x 9	40	41

(inches)	A	B	C	D	E	G	H	J	K
PV10EK	1.17	5.85	1.48	4.52	NW10	2.3	M4 x 7	0.78	1.6
PV16EK	1.56	6.24	1.48	4.91	NW16	2.69	M4 x 7	0.78	1.6
PV25EK	1.95	7.1	1.99	5.54	NW25	3.2	M4 x 7	0.78	1.6
PV40EK	2.54	8.97	2.96	6.63	NW40	4.29	M6 x 9	1.56	1.6

Technical Data

Valve actuation type	Single acting, electrically opened, spring closed
Pressure range valve open	1 x 10 ⁻⁹ to 2000 mbar 7.5 x 10 ⁻¹⁰ to 1500 Torr (30 psi)
Maximum pressure differential	
opening/closing	1000 mbar / 750 Torr
Leak rate	< 1 x 10 ⁻⁹ mbar ls ⁻¹ < 7.5 x 10 ⁻¹⁰ Torr ls ⁻¹
Reed switch (peak ratings)	
Maximum voltage	24 V a.c. or d.c.
Maximum current	0.25 A
Maximum power	3 VA
Maximum cycle frequency	400 h ⁻¹
Ambient operating temperature	
PV10/16	5 °C to 45 °C
PV25/40	5 °C to 50 °C
Valve temperature above ambient	
Rapid cycling	
PV10/16	<25 °C
PV25/40	<20 °C
Valve open	<10 °C
Bellows reliability MTTF	
PV10/16	500000 cycles
PV25/40	130000 cycles
Construction materials	
PVEKA	HE30TF aluminium
PVEKS	AISI304 stainless steel
Bellows	AISI316L stainless steel
O-ring	Fluoroelastomer

Ordering Information

Product Description	Order No.
PV10EKA, 110-127V 1-ph 50/60Hz, aluminium	C41103000
PV10EKA, 220-240V 1-ph 50/60Hz, aluminium	C41101000
PV16EKA, 110-127V 1-ph 50/60Hz, aluminium	C41203000
PV16EKA, 220-240V 1-ph 50/60Hz, aluminium	C41201000
PV16EKS, 110-127V 1-ph 50/60Hz, stainless steel	C41204000
PV16EKS, 220-240V 1-ph 50/60Hz, stainless steel	C41202000
PV25EKA, 110-127V 1-ph 50/60Hz, aluminium	C41303000
PV25EKA, 220-240V 1-ph 50/60Hz, aluminium	C41301000
PV25EKS, 110-127V 1-ph 50/60Hz, stainless steel	C41304000
PV25EKS, 220-240V 1-ph 50/60Hz, stainless steel	C41302000
PV40EKA, 110-127V 1-ph 50/60Hz, aluminium	C41403000
PV40EKA, 220-240V 1-ph 50/60Hz, aluminium	C41401000
PV40EKS, 110-127V 1-ph 50/60Hz, stainless steel	C41404000
PV40EKS, 220-240V 1-ph 50/60Hz, stainless steel	C41402000
Accessories & Spares	Order No.
PV10/16MK O-Ring Kit	C41101800
Spares Kit Pad & Body O-ring PV25EK	C41301800
PV40MK O-Ring kit	C41401800
Moving Pole Assy PV10E	C41101007
Moving Pole Assy PV25EK	C41301007
Moving Pole Assy PV40E	C41401007
Valve Body PV10KA	C41101816
Valve body PV16KA	C41201816
Valve Body PV16KS	C41602801
Valve Body PV25KA	C41301816
Valve Body PV25KS	C41622801
Valve Body PV40KA	C41401816
Valve Body PV40KS	C41642801

IPVEK Solenoid Operation In-Line Isolation valves



The Edwards IPVEK series valves are compact, light-weight electromagnetic vacuum valves suitable for use in vacuum pipeline systems down to 1×10^{-9} mbar. A double wound coil combined with an electronic switching circuit ensures low energy consumption, low operating temperatures and extended operating life.

Bellows sealed, the IPVEK solenoid operated in-line valves are available with either aluminum (A) or stainless steel (S) bodies, with an overall MTTF of up to 500,000 cycles.



Features & Benefits

- Transient high power for opening - electronically switched
- Low energy consumption in the 'hold open' position
- Enclosure rating to IP55
- Grease free vacuum
- MTTF up to 500000 cycles

Dimensions

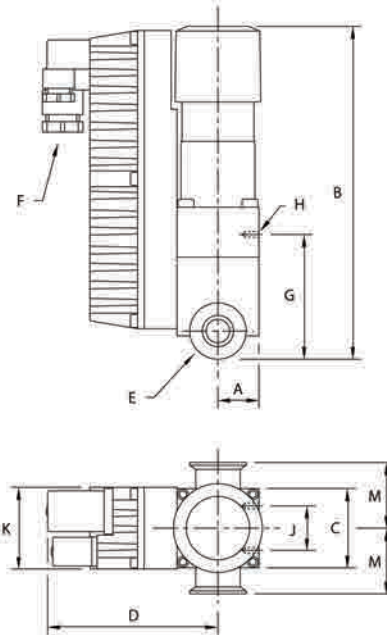

(mm)	A	B	C	D	E	G	H	J	K	M
IPV16EK	19	142.9	38	85	NW16	37.4	M4 x 7	20	41	40
IPV25EK	25.4	172	51	93	NW25	72.5	M4 x 7	20	41	50
IPV40EK	38.1	222	76	111	NW40	101.5	M6 x 9	40	41	65

(inches)	A	B	C	D	E	G	H	J	K	M
IPV16EK	0.7	5.57	1.48	3.32	NW16	1.46	M4 x 7	0.78	1.6	1.56
IPV25EK	1.0	6.7	1.99	3.63	NW25	2.83	M4 x 7	0.78	1.6	1.95
IPV40EK	1.5	8.69	2.96	4.33	NW40	3.96	M6 x 9	0.78	1.6	2.54

F Connectors for electrical supply and reed switch cables.

Technical Data

Valve actuation type	Single acting, electrically opened, spring closed
Pressure range valve open	1 x 10 ⁻⁹ to 2000 mbar 7.5 x 10 ⁻¹⁰ to 1500 Torr (30 psi)
Maximum press differential	
Opening/closing	1000 mbar / 750 Torr
Leak rate	< 1 x 10 ⁻⁹ mbar ls ⁻¹ < 7.5 x 10 ⁻¹⁰ Torr ls ⁻¹
Reed switch (peak ratings)	
Maximum voltage	24 V a.c. or d.c.
Maximum current	0.25 A
Maximum power	3 VA
Maximum cycle frequency	400 h ⁻¹
Ambient operating temperature	5 °C to 45 °C
Valve temperature above ambient	
Rapid cycling	<25 °C
Valve open	<10 °C
Bellows reliability MTTF	500000 cycles
Construction materials	
IPVEKA	HE30TF aluminum
Bellows	AISI316L stainless steel
O-ring	Fluoroelastomer
Molecular conductance (ls ⁻¹)	2
Time to open (ms)	40
Time to close (ms)	100
Operating power (VA)	
220 V a.c. at 25 °C pulse	417
220 V a.c. at 25 °C hold	4.7
Maximum continuous power 220 V a.c. rms (W)	4.5
Weight (g/oz)	800/28

Ordering Information

Product Description	Order No.
IPV16EKA, 220-240V, 1-ph 50/60Hz, aluminium	C41610000
IPV16EKA, 110-127V 1-ph 50/60Hz, aluminium	C41611000
IPV16EKS, 110-127V 1-ph 50/60Hz, stainless steel	C41613000
IPV25EKA, 220-240V 1-ph 50/60Hz, aluminium	C41630000
IPV25EKA, 110-127V 1-ph 50/60Hz, aluminium	C41631000
IPV25EKS, 220-240V 1-ph 50/60Hz, stainless steel	C41632000
IPV25EKS, 110-127V 1-ph 50/60Hz, stainless steel	C41633000
IPV40EKA, 220-240V 1-ph 50/60Hz, aluminium	C41651000
IPV40EKA, 110-127V 1-ph 50/60Hz, aluminium	C41652000
IPV40EKS, 220-240V 1-ph 50/60Hz, stainless steel	C41653000
IPV40EKS, 110-127V 1-ph 50/60Hz, stainless steel	C41654000
Accessories & Spares	Order No.
IEC plug to mating socket for PVEK valves	C41101090
Moving Pole Assy PV10E	C41101007
Moving Pole Assy PV25EK	C41301007
Moving Pole Assy PV40E	C41401007
PV10/16MK O-Ring Kit	C41101800
PV40MK O-Ring kit	C41401800
Spares Kit Pad & Body O-ring PV25EK	C41301800
Valve Body IPV16KS	C41602811
Valve body IPV16PKA	C41601802
Valve Body IPV25KA	C41621802
Valve Body IPV25KS	C41622811
Valve Body IPV40KA	C41641802
Valve Body IPV40KS	C41642811
Valve body PV16KA	C41201816

LCPVEK Solenoid Operation Isolation valves



Edwards' aluminum right angle LCPVEK valves are designed for vacuum applications which need a compact, simple, solenoid operation valve to control gas flow. These economical valves are ideal for a number of duties ranging from simple laboratory pump isolation to OEM vacuum system integration and design. Their versatility makes them effective both in vacuum pipelines and in chamber admittance applications.

Careful design of the solenoid power control and vacuum isolation components delivers efficient magnetic actuation with optimum vacuum performance at an affordable price. This facilitates the use of an electrically actuated valve in many applications where previously this had been uneconomic.



Features & Benefits

- Economical design can be used in low budget applications
- Electrical actuation
- Low power requirements
- Electronic boost power supply
- Efficient magnetic design

Dimensions

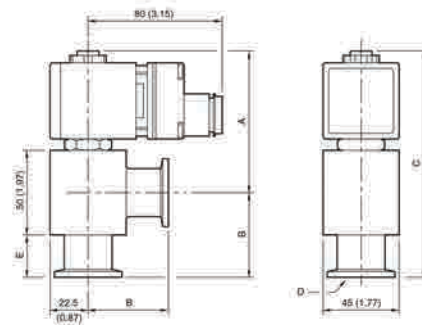

(mm)	A	B	C	D	E
LCPV16EK	95	40	135	NW16	17.5
LCPV25EK	92.5	50	142.5	NE25	25
(inches)	A	B	C	D	E
LCPV16EK	3.33	1.56	4.89	NW16	0.69
LCPV25EK	3.24	1.95	5.19	NW25	0.98

Technical Data

Valve actuation type	Single acting, electrically opened, spring return
Molecular conductance	3 ls ⁻¹
Pressure range	1 x 10 ⁻⁶ - 1000 mbar 7.5 x 10 ⁻⁷ - 750 Torr
Max pressure differential (open/close)	1000 mbar / 750 Torr
Time to open	60 ms
Time to close	<20 ms
Max cycle frequency	1800 h ⁻¹
Leak rate	< 1 x 10 ⁻⁶ mbar ls ⁻¹ < 7.5 x 10 ⁻⁷ Torr ls ⁻¹
Power consumption	
Open	95 W for 60 ms
Hold	2.5 to 4 W
Operating temperature range	5 to 45 °C
Weight	
LCPV16EK	810g / 28oz
LCPV25EK	840g / 29oz
Enclosure rating	IP67
Voltage	
230V	±10%
110V	-10% +15%
Construction materials	
Body	Aluminium, stainless steel
Seals	Fluoroelastomer

Ordering Information

Product Description	Order No.
LCPV16EKA, 110V, 50/60Hz, aluminium	C41751100
LCPV16EKA, 230V 50/60Hz aluminium	C41751000
LCPV25EKA, 110V 50/60Hz, aluminium	C41752100
LCPV25EKA, 230V, 50/60Hz, aluminium	C41752000

LCPVEK Solenoid Operation Isolation valves 24V



Edwards' aluminum LCPVEK valves are designed for vacuum applications which need a compact, simple, solenoid operation valve to control gas flow. These economical valves are ideal for a number of duties ranging from simple laboratory pump isolation to OEM vacuum system integration and design. Their versatility makes them effective both in vacuum pipelines and in chamber admittance applications.

Careful design of the solenoid power control and vacuum isolation components delivers efficient magnetic actuation with optimum vacuum performance at an affordable price. This facilitates the use of an electrically actuated valve in many applications where previously this had been uneconomic.



Features & Benefits

- Economical design can be used in low budget applications
- Electrical actuation
- Low power requirements
- Electronic boost power supply
- Efficient magnetic design

Dimensions

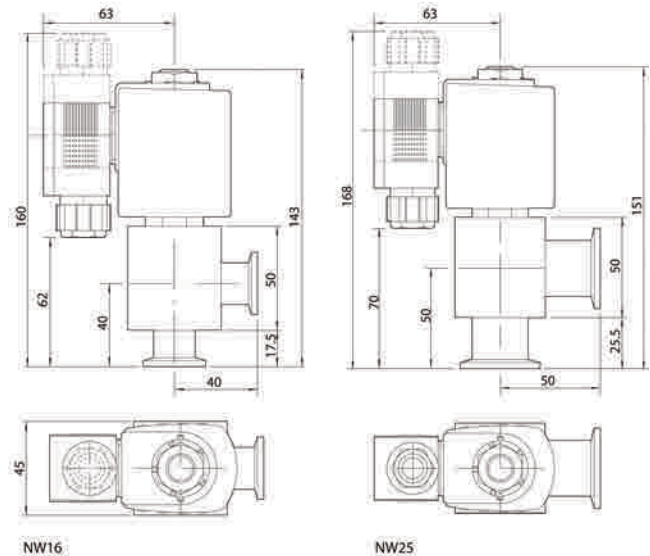

Technical Data

Valve actuation type	Single acting, electrically opened, spring return
Molecular conductance	1.5 ls ⁻¹
Pressure range	1 x 10 ⁻⁶ - 1000 mbar 7.5 x 10 ⁻⁷ - 750 Torr
Max pressure differential (open/close)	1000 mbar / 750 Torr
Time to open	20 ms
Time to close	50 ms
Max cycle frequency	600 h ⁻¹
Leak rate	Typically 1 x 10 ⁻⁶ mbar ls ⁻¹ Typically 7.5 x 10 ⁻⁷ Torr ls ⁻¹
Power consumption	
Open	72W for 400 ms
Hold	Typically 5W
Operating temperature range	-10 to 55 °C
Weight	
LCPV16EK	900g / 31oz
LCPV25EK	900g / 31oz
Enclosure rating	IP65
Voltage	
24V a.c/d.c.	+/- 10%
Construction materials	
Body	Aluminium, stainless steel, silver
Seals	FKM Fluoroelastomer

Ordering Information

Product Description	Order No.
LCPV16EKA, 24V ac,dc, aluminium	C41780200
LCPV25EKA, 24V ac,dc, aluminium	C41790200

BRV Backing/Roughing Valve



Edwards backing/roughing valves with ISO NW roughing and forepump terminations feature manual or pneumatic actuation. They combine the function of separate backing/roughing valves in one integral 3 port unit.

A flexible neoprene connector is supplied for the backing connection. The roughing and forepump ports terminate in the appropriate NW termination.



Features & Benefits

- Easy to operate - both ports closed position
- Long life - 100,000 operations or more
- Position indicator on pneumatic valve
- Leak tight to better than 10^{-9} mbar ls⁻¹ / 8×10^{-10} Torr ls⁻¹

Dimensions

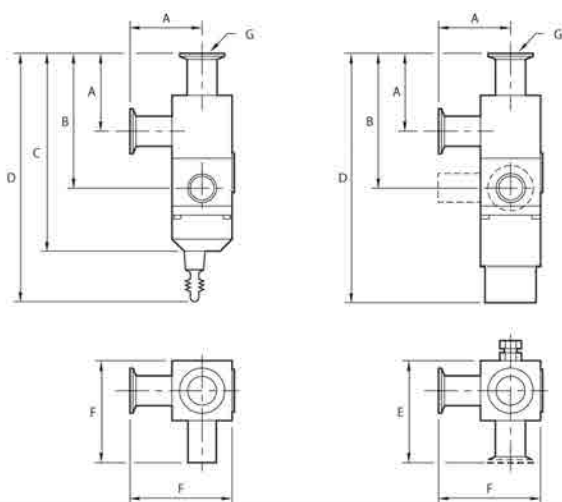

(mm)	A	B	C	D	E	F	G
BRV10K	30	90	134	169	52.5	49	NW10
BRV10PK	30	90	-	198	52.5	49	NW10
BRV25K	50	98	155	195	82	75	NW25
BRV25PK	50	98	-	203	82	75	NW25

(inches)	A	B	C	D	E	F	G
BRV10K	1.17	3.51	5.23	6.59	2.05	1.91	NW10
BRV10PK	1.17	3.51	-	7.72	2.05	1.91	NW10
BRV25K	1.95	3.82	6.05	7.61	3.2	2.93	NW25
BRV25PK	1.95	3.82	-	7.92	3.2	2.93	NW25

Applications

- The valves have been designed particularly for the Diffstak[®] pumping systems, but have applications where a compact change-over valve is required in the pressure range 10^{-7} - 2000 mbar / 8×10^{-8} - 1500 Torr.

Ordering Information

Product Description	Order No.
BRV10K, Manual Operation	C32103000
BRV10PK Backing/Roughing Valve Pneumatic Operation	C32104000
BRV25K Backing/Roughing Valve, Manual Operation	C32303000
BRV25PK Backing/Roughing Valve, Pneumatic Operation	C32304000
BRV25PK Backing/Roughing Valve, Pneumatic Operation, In-line Flanges	C32304900
BRV25PK Backing/Roughing Valve, Pneumatic Operation, All NW25 Flanges	C32303500

Accessories & Spares	Order No.
NW10 Flexible Sleeve For 15mm OD Tube	C26501002
NW25 Flexible Sleeve For 28mm OD Tube	C26501004
O Ring Viton 1119 Pk 2	H02106119
O Ring Viton 0215 Pk 5	H02106025
O Ring Viton 024 Pk 5	H02106261
O Ring Viton Vit 031 Pk 2	H02106262
5 Port Lightweight Electropneumatic Control Valve 24V a.c.	B28703030
5 Port Lightweight Electropneumatic Control Valve 24V d.c.	B28703055
5 Port Lightweight Electropneumatic Control Valve 110V a.c.	B28703031
5 Port Lightweight Electropneumatic Control Valve 230V a.c.	B28703032

Technical Data

Construction materials

Body and pneumatic cylinder	HE 30TF aluminum
Lever and bonnet (manual)	Glass reinforced plastic
Operating shaft/valve seat	Stainless steel
Body seals, port seals, shaft seal 'O' ring	Fluoroelastomer
Leak rate	
Overall	$< 10^{-9}$ mbar ls ⁻¹ $< 8 \times 10^{-10}$ Torr ls ⁻¹
Across ports	$< 10^{-9}$ mbar ls ⁻¹ $< 8 \times 10^{-10}$ Torr ls ⁻¹
NW coupling	$< 10^{-9}$ mbar ls ⁻¹ $< 8 \times 10^{-10}$ Torr ls ⁻¹
Operating pressure range	10^{-7} - 2100 mbar 8×10^{-8} - 1575 Torr
Max baking temperature	
Pneumatic	70 °C
Manual	90 °C
Reliability (MTTF)	100000 cycles
Recommended air pressure	2.8 - 4.2 bar / 40.6 - 61 psi
Maximum air pressure	7.0 bar / 102 psi
Minimum air pressure	2.4 bar / 35 psi
Air connections	1/8 in BSP, for 6 mm Ø plastic or copper tube
Microswitch rating	24 V 1.5 A a.c. or d.c.
Weight	
BRV10K	350g / 12oz
BRV10PK	380g / 13oz
BRV25K	860g / 30oz
BRV25PK	900g / 31.7oz

SIPVP Soft-Start Isolation Valves



Soft-start, pneumatically operated, in-line valves with interchangeable orifices for the controlled pumpdown of processes where turbulent flow can cause problems with particulate contamination. Slave and master valve combination allows slow initial pumping to minimise disturbance. Both slave and master valves require separate pneumatic connections.



Features & Benefits

- MTTF of 5000000 cycles
- Controlled pump down to match process
- Aluminum bodies
- Fast acting valves in the event of power failure
- Supplied with 5 mm, 6 mm and 7 mm interchangeable orifices

Applications

- When the slave valve is opened gas flows at a low rate between the two sides of the valve through interchangeable orifices allowing slow pumping. Having reached a predetermined pressure level specified by the user, the master valve is opened by means of a user supplied signal allowing full bore pumping. The bellows sealed valves are single acting with pneumatic opening and spring closure. They are supplied with three interchangeable orifices to enable pumping characteristics to be matched to your process. A microswitch is supplied as standard to indicate valve status. Both the valve and the microswitch can be baked to 100°C to speed up degassing, and to prevent process gases from condensing inside the valve. While designed primarily for the semiconductor industry the valve can also be used in other applications requiring controlled pump-down.

Dimensions

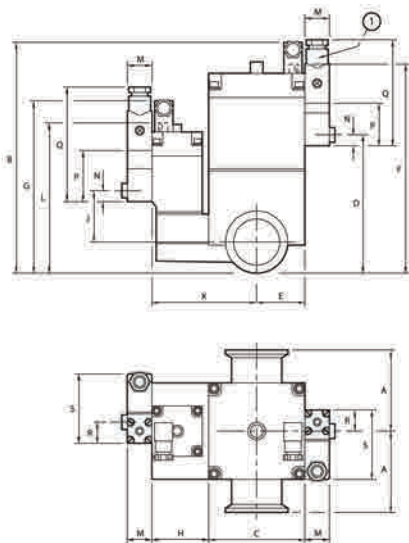

SIPV25P	A	B	C	D	E	F
mm	50	161.9	50.8	68.2	25.8	144.3
inches	1.95	6.31	1.98	2.66	1	5.63
SIPV40P						
mm	65	192.2	76.2	68.2	38.2	174.6
inches	2.54	7.49	2.97	2.66	1.49	6.81
SIPV25P / SIPV40P	G	H	J	K	L	M
mm	145	43.5	49	86	127	20
inches	5.66	1.69	1.91	3.35	4.95	0.78
	N	P	Q	R	S	
mm	10	40	88	19	59	
inches	0.39	1.56	3.43	0.74	2.3	

Performance Curves

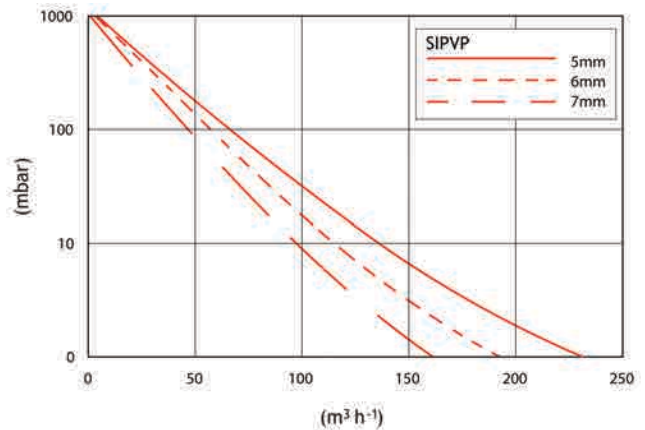

Typical pump-down curve of initial pumping phase with 80 m³h⁻¹ pump on a 66l chamber

Technical Data

Valve actuation type	Single acting, pneumatically opened, spring closed
Pressure range	1 x 10 ⁻⁹ to 2100 mbar 8 x 10 ⁻¹⁰ to 1575 Torr
Maximum pressure differential	
Opening	1000 mbar / 750 Torr
Closing	2100 mbar / 1575 Torr
Leak rate	10 ⁻⁹ mbar ls ⁻¹ 10 ⁻¹⁰ Torr ls ⁻¹
Pneumatic connector	Rp 1/8 (1/8 inch BSP)*
Pneumatic operating pressure	2.8 to 4.2 bar / 41 to 61 psi
Electrical indicator	Single microswitch
Microswitch electrical rating	24 V, 1.5 A a.c. or d.c.
Max cycle frequency	900 h ⁻¹
Bellows reliability, MTTF	5000000 cycles
Ambient operating temperature	5 - 100 °C
Maximum baking temperature	100 °C
Construction materials	HE30TF aluminum
O-ring	Fluoroelastomer
Time to open/close at 4 bar (ms)	SIPV25P (SIPV40P)
Slave valve	60/20 (60/20)
Master valve	15/41 (50/155)
Weight (g / oz)	
SIPV25P	920 / 32
SIPV40P	1760 / 62

* With optional control valve fitted

Ordering Information

Product Description	Order No.
SIPV25P, pneumatic, bellows sealed, aluminium body	C41624000
SIPV40P, pneumatic, bellows sealed, aluminium body	C41644000
Accessories & Spares	Order No.
3 Port Electropneumatic Control Valve 110V a.c.	H06200126
3 Port Electropneumatic Control Valve 230V a.c.	H06200138
3 Port Electropneumatic Control Valve 24V a.c.	H06200125
3 Port Electropneumatic Control Valve 24V d.c.	H06200124

The BGV basement gate valves are a range of stainless steel, bellows-sealed basement isolation valves. They have been designed, in conjunction with VAT, to enable pumps to be kept running during foreline maintenance in order to maximise the reliability and up-time of pumps operating on harsh processes. The BGV valves are designed for an operating pressure range of 1×10^{-9} mbar to 1.2 bar absolute (1×10^{-7} to 1.2×10^5 Pa). The valves withstand 1.2 bar absolute in either direction and can tolerate against a 1 bar differential pressure across the valve seal.

Although principally designed for isolation of pumps in a semiconductor fab basement, the BGV valves are ideal for other applications where a 1 bar differential at opening is desirable and 20000 cycles is acceptable.



Features & Benefits

- Jointly developed with VAT, a world leader in sealing technology.
- Stainless steel construction and robust patented design for a long service life
- Simple grease-free mechanism minimizes damage due to particulates in dusty processes
- Can be operated with 1 bar pressure differential so pressure equalization is not required
- Easy servicing with only inexpensive consumables for low cost of ownership

Dimensions

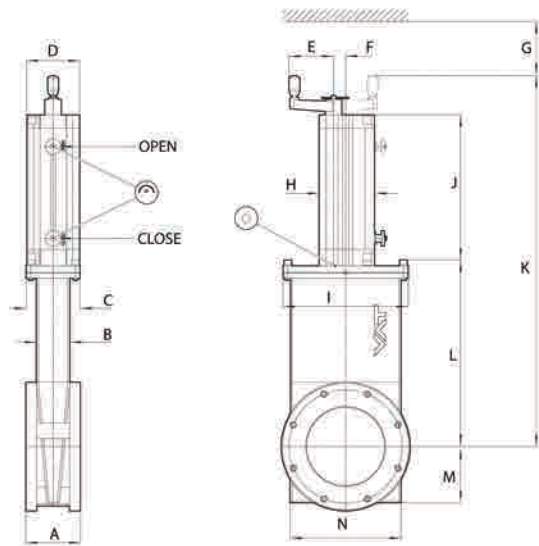

		NW50	ISO63	ISO80	ISO100	ISO160
A	mm/inch	60/2.36	70/2.75	70/2.75	70/2.75	90/3.54
B	mm/inch	36/1.41	43/1.69	43/1.69	43/1.69	64/2.52
C	mm/inch	63/2.48	69/2.71	69/2.71	69/2.71	87/3.42
D	mm/inch	62/2.44	62/2.44	62/2.44	62/2.44	62/2.44
E	mm/inch	60/2.36	68/2.67	68/2.67	68/2.67	87/3.42
F	mm/inch	120/4.72	160/6.3	200/7.87	200/7.87	260/10.23
G	mm/inch	62.5/2.46	71/2.79	71/2.79	71/2.79	91/3.58
H	mm/inch	70.5/2.77	75/2.95	75/2.95	75/2.95	85/3.34
I	mm/inch	119/4.68	138/5.43	155/6.09	174.5/6.86	241/9.47
J	mm/inch	110/4.32	123/4.83	142/5.58	160/6.29	210/8.25
K	mm/inch	268/10.53	314/12.34	364/14.31	413.5/16.25	578/22.72
L	mm/inch	149/5.86	176/6.92	209/8.21	239/9.39	337/13.24
M	mm/inch	45/1.77	53.5/2.1	72/2.83	72/2.83	97/3.81
N	mm/inch	90/3.54	105/4.13	124/4.87	142/5.58	192/7.55

Technical Data

Leak rate	
Body	$< 1 \times 10^{-9}$ mbar ls ⁻¹
Valve seat	$< 1 \times 10^{-7}$ mbar ls ⁻¹
Pressure range	1 x 10 ⁻⁹ mbar to 1.2 bara
Differential pressure on the gate	1.2 bar in either direction
Differential pressure at opening	1 bar
Cycles until first service	20, 0000
Maximum operating temps	
Valve body	120 °C
Manual actuator	80 °C
Pneumatic actuator	80 °C
Position indicator	60 °C
Solenoid	50 °C
Molecular flow conductance	
NW50	300 ls ⁻¹
ISO63	400 ls ⁻¹
ISO80	1100 ls ⁻¹
ISO100	1700 ls ⁻¹
ISO160	4600 ls ⁻¹
Weight	
NW50	3.3 kg (7.3 lbs)
ISO63	6.6 kg (14.6 lbs)
ISO80	7.0 kg (15.4 lbs)
ISO100	8.5 kg (18.7 lbs)
ISO160	17.7 kg (39.0 lbs)
Materials of construction:	
Body	AISI 304 stainless steel
Bonnet	Black anodized aluminium
Gate	AISI 304 stainless steel
Gliders	PEEK
Bellows	AISI 633 stainless steel
Seals	Fluoroelastomer
Gate fixation screw	A2 stainless steel Ni-TEFLON coated
Handle	Reinforced polyamide
Manual Valves	
Turns of the handle to open/close	
NW50	22
ISO63	27
ISO80	33
ISO100	39
ISO160	41

Ordering Information

Product Description	Order No.
BGV manual gate valve NW50	B90000195
Accessories & Spares	Order No.
Vacuum seals kit NW50	B90000595
Vacuum seals kit ISO63	B90000600
Vacuum seals kit ISO80	B90000605
Vacuum seals kit ISO100	B90000610
Vacuum seals kit ISO160	B90000620
Bellows feed-through NW50	B90000625
Bellows feed-through ISO63	B90000630
Bellows feed-through ISO80	B90000635
Bellows feed-through ISO100	B90000640
Bellows feed-through ISO160	B90000650
Spare gate NW50	B90000655
Spare gate ISO63	B90000660
Spare gate ISO80	B90000665
Spare gate ISO100	B90000670
Spare gate ISO160	B90000680
Spare solenoid 24V a.c./d.c.	B90000790

The BGV basement gate valves are a range of stainless steel, bellows-sealed basement isolation valves. They have been designed, in conjunction with VAT, to enable pumps to be kept running during foreline maintenance in order to maximise the reliability and up-time of pumps operating on harsh processes. The BGV valves are designed for an operating pressure range of 1×10^{-9} mbar to 1.2 bar absolute (1×10^{-7} to 1.2×10^5 Pa). The valves withstand 1.2 bar absolute in either direction and can tolerate against a 1 bar differential pressure across the valve seal.

Although principally designed for isolation of pumps in a semiconductor fab basement, the BGV valves are ideal for other applications where a 1 bar differential at opening is desirable and 20000 cycles is acceptable.



Features & Benefits

- Jointly developed with VAT, a world leader in sealing technology.
- Stainless steel construction and robust patented design for a long service life
- Simple grease-free mechanism minimizes damage due to particulates in dusty processes
- Can be operated with 1 bar pressure differential so pressure equalization is not required
- Easy servicing with only inexpensive consumables for low cost of ownership

Dimensions

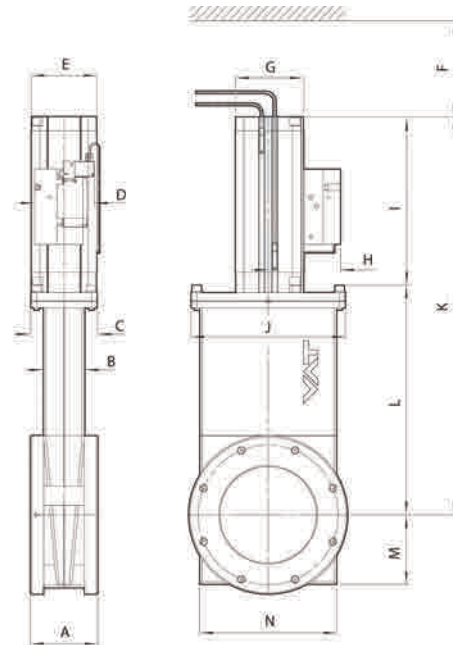

		NW50	ISO63	ISO80	ISO100	ISO160
A	mm/inch	60/2.36	70/2.75	70/2.75	70/2.75	90/3.54
B	mm/inch	36/1.41	43/1.69	43/1.69	43/1.69	52.5/2.06
C	mm/inch	63/2.48	69/2.71	69/2.71	69/2.71	87/3.42
D	mm/inch	60/2.36	68/2.67	68/2.67	68/2.67	87/3.42
E	mm/inch	57/2.24	57/2.24	57/2.24	57/2.24	73/2.87
F	mm/inch	13/0.51	15.5/0.61	15.5/0.61	15.5/0.61	20.3/0.8
G	mm/inch	120/4.71	160/6.3	200/7.87	200/7.87	260/10.23
H	mm/inch	62.5/2.46	71/2.79	71/2.79	71/2.79	91/3.58
I	mm/inch	110/4.32	123/4.84	142/5.58	160/6.3	210/8.26
J	mm/inch	134/5.27	149/5.86	165/6.49	185/7.28	264/10.39
K	mm/inch	333/13.09	375/14.76	424/16.66	474/18.66	651/25.62
L	mm/inch	149/5.86	176/6.92	209/8.21	239/9.4	337/13.27
M	mm/inch	45/1.77	53.5/2.1	72/2.83	72/2.83	97/3.83
N	mm/inch	90/3.54	105/4.13	124/4.87	142/5.59	192/7.55

Technical Data

Leak rate	
Body	$< 1 \times 10^{-9}$ mbar ls ⁻¹
Valve seat	$< 1 \times 10^{-7}$ mbar ls ⁻¹
Pressure range	1×10^{-9} mbar to 1.2 bara
Differential pressure on the gate	1.2 bar in either direction
Differential pressure at opening	1 bar
Cycles until first service	20, 0000
Maximum operating temperatures	
Valve body	120 °C
Manual actuator	80 °C
Pneumatic actuator	80 °C
Position indicator	60 °C
Solenoid	50 °C
Molecular flow conductance	
NW50	300 ls ⁻¹
ISO63	400 ls ⁻¹
ISO80	1100 ls ⁻¹
ISO100	1700 ls ⁻¹
ISO160	4600 ls ⁻¹
Weight	
NW50	3.3 kg (7.3 lbs)
ISO63	6.6 kg (14.6 lbs)
ISO80	7.0 kg (15.4 lbs)
ISO100	8.5 kg (18.7 lbs)
ISO160	17.7 kg (39.0 lbs)
Materials of construction:	
Body	AISI 304 stainless steel
Bonnet	Black anodized aluminum
Gate	AISI 304 stainless steel
Gliders	PEEK
Bellows	AISI 633 stainless steel
Seals	Fluoroelastomer
Gate fixation screw	A2 stainless steel Ni-teflon coated
Handle	Reinforced polyamide
Pneumatic valves	
Solenoid rating	
Standard solenoid	24 V - 15% / + 10%, AC/DC, 2.4 W
Position indicator contact rating	12 - 30 V AC/DC, max 500 mA, max 10 W
Pneumatic supply	
Min supply pressure	58 psig (4 bar gauge, 5 bar absolute, 5×10^5 Pa)
Max supply pressure	100 psig (7 bar gauge, 8 bar absolute, 8×10^5 Pa)
Pneumatic connection	R1/8 inch (1/8 inch NPT for valves ordered in USA)

Ordering Information

Product Description	Order No.
BGV pneumatic gate valve NW50	B90003105
BGV pneumatic gate valve ISO63	B90003110
BGV pneumatic gate valve ISO80	B90003125
BGV pneumatic gate valve ISO100	B90003130
BGV pneumatic gate valve ISO160	B90003140
Accessories & Spares	Order No.
Vacuum seals kit NW50	B90000595
Vacuum seals kit ISO63	B90000600
Vacuum seals kit ISO80	B90000605
Vacuum seals kit ISO100	B90000610
Vacuum seals kit ISO160	B90000620
Bellows feed-through NW50	B90000625
Bellows feed-through ISO63	B90000630
Bellows feed-through ISO80	B90000635
Bellows feed-through ISO100	B90000640
Bellows feed-through ISO160	B90000650
Spare gate NW50	B90000655
Spare gate ISO63	B90000660
Spare gate ISO80	B90000665
Spare gate ISO100	B90000670
Spare gate ISO160	B90000680
Spare solenoid 24V a.c./d.c.	B90000790
BGV mk2 TIM interface cable	B90003388

GV Manual and Pneumatic Gate Valves



The Edwards GV range of stainless steel, bellows sealed gate valves is designed for applications requiring overall leak tightness and a minimum of hydrocarbon in the residual atmosphere.

These superior quality valves offer high vacuum integrity coupled with maximum conductance. The valves are available with flange options of ISO, CF (metal sealed) for applications at ultra high vacuum requiring increased bakeout temperatures.

The stainless steel valve bodies are vacuum brazed, a special process which includes a bakeout at 1100 °C. This eliminates any possibility of virtual leaks and ensures a product with low outgassing characteristics.

A laser welded stainless steel bellows effectively seals the actuator from the valve. The concept provides ease of servicing and allows the gate and linkage mechanism to be removed while the valve remains in situ.

Features & Benefits

- In situ removal of gate and linkage mechanism for easy servicing
- Virtual leaks eliminated due to vacuum brazed manufacture
- Electropolished finish inside and outside
- Compact design with high conductance
- Manual or pneumatic options
- Microswitch position indicator as standard on pneumatic version
- Long periods of use between maintenance
- Low vibration and shock
- Free choice of orientation
- Wide range from 40 mm / 1.56 inch bore up to 320 mm / 12.48 inch bore
- Flange options – ISO, CF (metal sealed)
- High reliability – 1000000 cycle option
- Optional 3 position operation
- Vacuum brazed to 1100 °C to eliminate virtual leaks

Dimensions

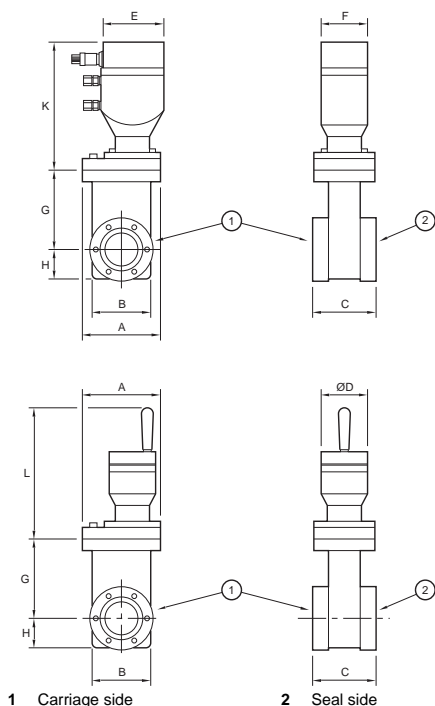

Technical Data

Pressure range	10 ⁻⁹ mbar to 1 bar (absolute) / 8 x 10 ⁻¹⁰ – 750 Torr
Leak rate	< 10 ⁻⁹ mbar l s ⁻¹ / 8 x 10 ⁻¹⁰ Torr l s ⁻¹
Maximum differential pressure on the valve plate	1 bar / 750 Torr in either direction
Maximum differential pressure on the valve plate at opening	20 mbar / 15 Torr
Position indicator switch, breaking capacity	24 V d.c., 5 A
Material of construction	
Body, valve plate	AISI 304 stainless steel
Mechanism	AISI 304 stainless steel
Bearings	Hardened high carbon chrome steel
Circlips	SS PH 15-7 Mo
Bellows	AM 350 stainless steel
Seals, valve plate	Fluoroelastomer
Bonnet	
Metal sealed valves	OFHC
Other valves	Fluoroelastomer
Bakeout temperature	
Valve body, valve open	150 °C (fluoroelastomer bonnet seal)
Valve body, valve open	250 °C (metal bonnet seal)
Valve closed	200 °C
Actuator, manual	200 °C
Actuator, pneumatic	100 °C
Average life until first service*	100000 closures
Mounting position	Any orientation
Pneumatic operating pressure	4 – 5.5 bar / 60 – 80 psi

* Dependent on the vacuum environment and the opening and closing speed

Flange Bore mm	Flange Bore in	Conductance in High Vacuum l s ⁻¹	Pneumatic Valve Minimum Closing & Opening Time at 5 bar, Seconds	Approx Weight, kg
40	1.5	130	0.5	5
50	2	250	0.5	6
63	2.5	520	1	8
100	4	2000	1.5	15
160	6	6300	1.5	23
200	8	15000	2 (close) 3 (open)	34
250	10	23000	3 (close) 4 (open)	73
320	12	39000	3 (close) 4 (open)	77

* Special versions available, including 1 million cycle types, 3 position types, larger valves, and pneumatic versions with reed switch position indicators.

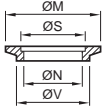
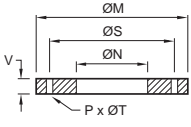
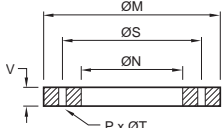
	Model No.	Body Dimensions (mm)										Flange Dimensions (mm)					
		A	B	C	Ø D	E	F	G	H	K	L	Ø M	Ø N	P	Ø S	Ø T	V
NW 	GVI 040	84.1	26.2	50.5	50.8	69.3	50.7	86.1	33.0	134.9	91.7	55.0	38.1	-	41.2	-	12.7
	GVI 050	96.8	75.2	50.5	50.8	69.3	50.7	104.5	37.6	134.9	91.7	75.0	50.8	-	52.2	-	12.7
ISO 	GVI 063	111.0	89.4	51.6	50.8	69.3	50.7	122.1	43.1	134.9	91.7	130.1	63.5	4	110.0	M8	12.7
	GVI 080	125.0	109.1	51.6	50.8	69.3	50.7	145.9	72.8	134.9	91.7	145.1	75.9	8	126.0	M8	12.7
	GVI 100	177.8	143.5	61.2	75.5	93.5	76.2	206.4	66.9	175.6	201.3	165.1	101.6	8	145.0	M8	12.7
	GVI 160	222.3	191.8	67.0	75.5	93.5	76.2	270.5	87.6	175.6	201.3	225.0	152.4	8	200.0	M10	16.0
	GVI 200	285.8	254.5	67.6	75.5	93.5	76.2	353.4	114.6	175.6	201.3	285.8	203.2	12	260.0	M10	15.9
	GVI 250	341.1	303.5	80.0	88.9	120.4	120.4	460.6	146.6	240.7	231.7	335.0	254.0	12	310.0	M10	19.0
	GVI 320	408.2	362.7	80.0	88.9	120.4	120.4	560.5	174.9	240.7	231.7	425.0	304.8	12	395.0	M12	19.0
CF 	GVC 015	84.1	62.5	51.6	50.8	69.3	50.7	86.1	33.0	134.9	91.7	69.3	38.1	6	58.7	M6	12.7
	GVC 020	96.8	75.2	57.9	50.8	69.3	50.7	104.5	37.6	134.9	91.7	85.7	50.8	8	72.4	M8	15.9
	GVC 025	111.0	89.4	61.2	50.8	69.3	50.7	122.1	43.1	134.9	91.7	113.5	63.5	8	92.2	M8	17.5
	GVC 040	177.8	143.5	75.4	75.9	93.5	76.2	206.4	66.9	175.6	190.6	151.6	101.9	16	130.3	M8	19.8
	GVC 060	222.3	191.8	80.5	75.9	93.5	76.2	270.5	87.6	175.6	200.2	202.4	152.4	20	181.1	M8	22.4
	GVC 080	285.8	254.5	85.1	75.9	93.5	76.2	353.4	114.6	175.6	200.2	253.2	203.2	24	231.9	M8	24.6
	GVC 100	341.4	303.5	98.8	88.9	120.4	101.6	460.6	146.6	240.7	231.7	304.8	254.0	32	284.0	M8	28.5
	GVC 120	403.2	362.7	98.8	88.9	120.4	101.6	560.5	174.9	240.7	231.7	354.6	304.8	30	325.4	M10	28.5

Ordering Information

Type	Model	Flange seals	No. seals*	Fixing kit	No. kits†
ISO	GVI 063	B27158170	1	B22417187	1
	GVI 100	B27158171	1	B22417187	2
	GVI 160	B27158172	1	B22417217	2
	GVI 200	B27158081	1	B22417217	2
	GVI 250	B27158143	1	B22417247	2
	GVI 320	B27158166	1	B22417247	2
CF	GVC 015	C10001290	10	B22417157	2
	GVC 020	C10005290	10	B22417187	2
	GVC 025	C10007490	10	B22417188	2
	GVC 040	C10009290	10	B22417189	2
	GVC 060	C10011290	5	B22417190	2
	GVC 080	C10012290	5	B22417190	2
	GVC 100	C10013290	5	B22417190	2

* Number of seals in each pack.

† Number of fixing kits that are needed to mount both flanges of the valve.

Ordering Information

Type	Flange	Nominal		Valve Ordering (Number)
		Bore mm/in	Model	
ISO Manual	NW40	40/1½	GVI040	B65001000
	NW50	50/2	GVI050	B65101000
	ISO63	63/2½	GVI063	B65201000
	ISO80	75/3	GVI080	N03933800
	ISO100	100/4	GVI100	B65301000
	ISO160	160/6	GVI160	B65401000
	ISO200	200/8	GVI200	B65501000
	ISO250	250/10	GVI250	B65601000
	ISO320	320/12	GVI320	B65701000
	ISO Pneumatic	NW40	40/1½	GVI040
NW50		50/2	GVI050	B65151000
ISO63		63/2½	GVI063	B65251000
ISO80		75/3	GVI080	U30002092
ISO100		100/4	GVI100	B65351000
ISO160		160/6	GVI160	B65451000
ISO200		200/8	GVI200	B65551000
ISO250		250/10	GVI250	B65651000
ISO320		320/12	GVI320	B65751000
CF Manual		2.37 inch od CF	40/1½	GVC015
	3.37 inch od CF	50/2	GVC020	B65103000
	4.47 inch od CF	63/2½	GVC025	B65203000
	6.00 inch od CF	100/4	GVC040	B65303000
	8.00 inch od CF	160/6	GVC060	B65403000
	10.00 inch od CF	200/8	GVC080	B65503000
	12.00 inch od CF	250/10	GVC100	B65603000
14.00 inch od CF	320/12	GVC120	B65703000	
CF Pneumatic	2.37 inch od CF	40/1½	GVC015	B65053000
	3.37 inch od CF	50/2	GVC020	B65153000
	4.47 inch od CF	63/2½	GVC025	B65253000
	6.00 inch od CF	100/4	GVC040	B65353000
	8.00 inch od CF	160/6	GVC060	B65453000
	10.00 inch od CF	200/8	GVC080	B65553000
	2.00 inch od CF	250/10	GVC100	B65653000
14.00 inch od CF	320/12	GVC120	B65753000	

QSB Quarter Swing Butterfly Valve



The QSB quarter swing valves are compact, quick acting, high conductance isolation valves. The QSB valves have a polished, stainless steel, ISO flanged body with fluoroelastomer 'O' ring sealed valve plate and shaft. The valve plate 'O' ring groove is vented to help maintain a stable high vacuum. The valve shaft 'O' rings and bearings are lubricated with Fomblin® grease to prevent gas bursts from behind the shaft seals.

This valve is supplied with a Co-Seal.



Features & Benefits

- Manual operation
- High conductivity
- Resists atmosphere in either direction
- Compact and quick acting
- Corrosion resistant construction

Dimensions

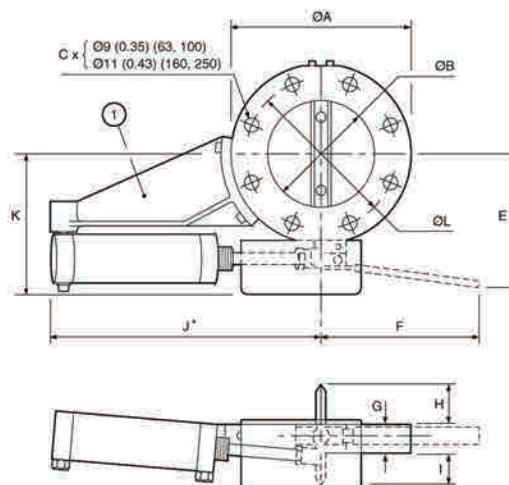

	A	B	C	E	F	G	H	I	J	K	OL
63	130	63	4	111	130	23.5	24.5	19	-	-	110
63P	130	63	4	105	-	23.5	24.5	19	235	108	110
100	165	96	8	125	130	26	41	33	-	-	145
100P	165	96	8	123	-	26	41	33	238	126	145
160	225	142.5	8	170	180	43.5	55	48.5	-	-	200
160P	225	142.5	8	166	-	43.5	55	48.5	263	166	200

1 Actuator cylinder support bracket (QSB63P, QSB100P and QSB160P only)

Technical Data

Valve plate material	AISI 304 stainless steel
Operating pressure range	10 ⁻⁹ - 3000 mbar 8 x 10 ⁻¹⁰ - 2250 Torr
Max pressure differential	1000 mbar / 750 Torr
Operating temp range	5 - 40 °C
Max baking temp	200 °C (without actuator)
Leak rate	< 10 ⁻⁹ mbar ls ⁻¹ 8 x 10 ⁻¹⁰ Torr ls ⁻¹
Pneumatic valves only:	
Reliability (MTTF)	>1.5 x 10 ⁵ cycles
Pneumatic connectors	1/8 inch BSP, for 6mm OD tube
Number of connectors	
QSB63, QSB100, QSB160	2
Reed switch rating	
Max voltage	30V
Max current	500mA
Max Power	6W
Reed switch connectors	3m flying leads
Microswitch rating	5A at 48V
Microswitch connectors	
QSB63, QSB100, QSB160	Solder tags
Flange Size	ISO63 up to ISO250
Conductance *	420 ls ⁻¹
QSB63	420 ls ⁻¹
QSB100	1250 ls ⁻¹
QSB160	2700 ls ⁻¹
Recommended pneumatic pressure~ (bar)	
QSB63, QSB100, QSB160	2.8 to 4.2

* Conductance of equivalent tube length
~ Pneumatic operation

Ordering Information

Product Description	Order No.
QSB63, Manual Operation	B42402000
QSB100, Manual Operation	B42602000
QSB160, Manual Operation	B42802000
QSB63P, Double Pneumatic Operation	B42403000
QSB100P, Double Pneumatic Operation	B42603000
QSB160P, Double Pneumatic Operation	B42803000
QSB63P, Double Pneumatic Operation with reed switches	B42409000
QSB100P, Double Pneumatic Operation with reed switches	B42609000
Accessories & Spares	Order No.
O Ring Viton 1161 Pk 1	H02106161
O Ring Viton 0340 Pk 1	H02106055
O Ring Viton Vit 1208 Pk 1	H02106208
Valve shaft seal O-Ring Vit0012 Pk5	H02106010
O Ring Viton Vit 0111 Pk 5	H02106011
5 Port Lightweight Electropneumatic Control Valve 24V a.c.	B28703030
5 Port Lightweight Electropneumatic Control Valve 24V d.c.	B28703055
5 Port Lightweight Electropneumatic Control Valve 110V a.c.	B28703031
5 Port Lightweight Electropneumatic Control Valve 230V a.c.	B28703032

AV5A Air Admittance Valve With Couplings



The AV5A is manufactured in aluminum alloy. It has a control knob attached to a screw-actuated plunger: turn the control knob clockwise to close the valve. A nitrile 'O' ring seals the plunger to the valve body.

The valve can be connected directly, pipeline supported or panel mounted, and is connected to the vacuum system with the Edwards SC5 coupling (supplied).



Dimensions

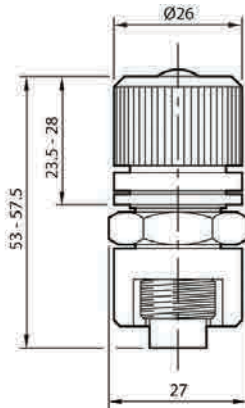

Technical Data

Materials of construction	HE30 aluminum / nickel plated brass
Body	HE30 aluminum
Plunger	Nitrile
Seal	
Leak rate across seat	10^{-7} mbar ls ⁻¹ / 8×10^{-8} Torr ls ⁻¹
Leak rate through body	10^{-1} mbar ls ⁻¹ / 8×10^{-2} Torr ls ⁻¹
Panel mounting	Ø 17 mm / Ø 0.66 in hole, 3 mm / 0.117 in maximum thickness
Vacuum connections	SC5 couplings or 3/8 inch BSP threaded body and bonded seal
Weight	85 g / 3 oz

Ordering Information

Product Description	Order No.
AV5A Air Admittance Valve With Couplings	C35003000
Accessories & Spares	Order No.
O Ring Nitrile Vor 2A Pk 10	H02105115
Dowty Seal 3/8 BSP MkC	H02104003



The AV10K is manufactured in aluminum alloy. It has a control knob attached to a screw-actuated plunger: turn the control knob clockwise to close the valve. A nitrile 'O' ring seals the plunger to the valve body.

The valve can be pipeline supported only, and is connected to the vacuum system with an NW10 fitting.

Dimensions

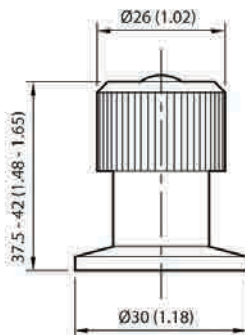

Technical Data

Materials of construction	
Body	HE30 aluminum
Control knob	Nylon 6
Seal	Nitrile
Leak rate across seat	10^{-7} mbar ls ⁻¹ / 8×10^{-8} Torr ls ⁻¹
Leak rate through body	10^{-1} mbar ls ⁻¹ / 8×10^{-2} Torr ls ⁻¹
Vacuum connections	NW10
Weight	100 g / 3.5 oz

Ordering Information

Product Description	Order No.
AV10K Air Admittance Valve	C35103000
Accessories & Spares	Order No.
O Ring Nitrile Vor 2A Pk 10	H02105115

LV10K Leak Valve NW10 Flanges



The LV10K needle valve provides fine control of gas bleed into a vacuum chamber or a regulated leak to control pressure in a vacuum system and is suitable for gas admission down to 10^{-5} mbar / 8×10^{-6} Torr. Suitable for pipeline or panel mounting.



Dimensions

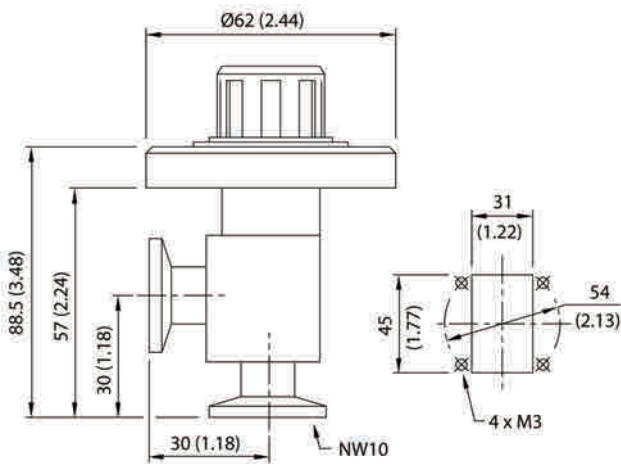

Technical Data

Materials of construction	
Body	Aluminium HE30
Seat	Brass BS2784 C2112
Needle	Martensitic stainless steel EN56AM
Filter	Brass BS249
Max flow rate (approx)*	0.1 ls^{-1}
Max inlet pressure	2000 mbar / 1500 Torr
Max leak rate, across seat	$10^{-7} \text{ mbar ls}^{-1}$ / $8 \times 10^{-8} \text{ Torr ls}^{-1}$
Max leak rate, across body	$10^{-7} \text{ mbar ls}^{-1}$ / $8 \times 10^{-8} \text{ Torr ls}^{-1}$
Vacuum connection	NW10
Weight (g/oz)	138 g / 4.8 oz

* Flow rate relates to a pressure differential across valve of one bar.

Ordering Information

Product Description	Order No.
LV10K Leak Valve NW10 Flanges	C37102000
Accessories & Spares	Order No.
Spares Kit Valve Seat	C37102812

Electropneumatic Control Valve



Electropneumatic control valves can be used to control the operation of pneumatically activated vacuum valves. Control valves are available with different electrical supply voltages and frequencies to suit your application.

Dimensions

Ordering Information

5

Page
202

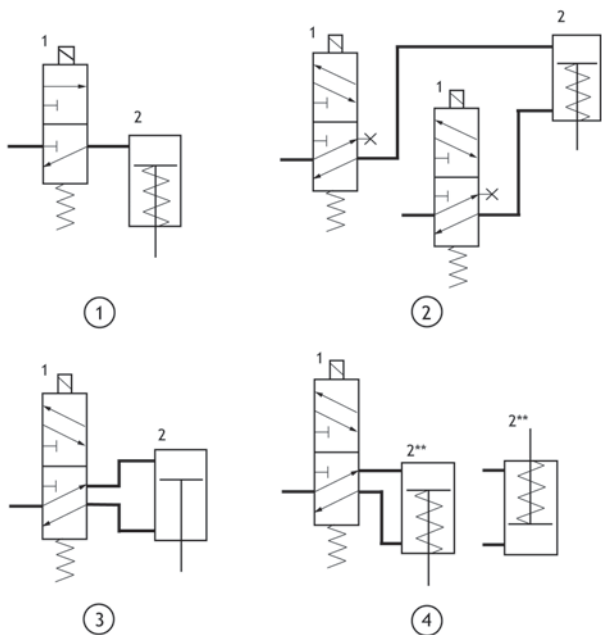

Figure 1 - Pneumatic circuit for 3-port control valve
 Figure 2 - Pneumatic circuit for two 5-port lightweight control valves
 Figure 3 - Pneumatic circuit 5-port lightweight control valve
 Figure 4 - Pneumatic circuit for 5-port control valve

Product Description

Order No.

3-Port, 24V d.c., 1/8 Inch BSP	H06200124
3-Port, 24 V a.c., 50/60 Hz, 1/8 Inch BSP	H06200125
3-Port, 48 V d.c., 1/8 Inch BSP, North America	H06200130
3-Port, 110 V a.c., 50/60 Hz, 1/8 Inch BSP	H06200126
3-Port, 230 V a.c., 50/60 Hz, 1/8 Inch BSP	H06200138
5-Port, 24 V d.c., 6mm BSP	B28703055
5-Port, 24 V a.c., 50/60 Hz, 6mm BSP	B28703030
5-Port, 110 V a.c., 50/60 Hz, 6mm BSP	B28703031
5-Port, 230 V a.c., 50/60 Hz, 6mm BSP	B28703032

Technical Data

Valve	Valve Type	Recommend Control Valve Configuration	Schematic
GV gate valves	Double-acting cylinder with no spring return	1 x 5-port	3
PVPK pipeline valves soft start	Single-acting cylinder with spring return	1 x 3-port	1
BRV backing/roughing valve	Double-acting cylinder with spring return to the mid-position (that is, isolated position)	2 x 5-port or (1 x 5-port)	2*(4†)
QSB63/100/160 quarter swing butterfly valves, Diffstak isolation-valves	Double-acting cylinder with no spring return	1 x 5-port	4
Supply pressure	3-port	5-port	
bar gauge	2.1 - 8	3.4 – 4.8	
Psig	30 – 115	50 - 70	

* This configuration allows the use of the isolated position of the vacuum valve.

† This configuration only allows the use of the roughing and backing positions of the vacuum valve.

This page is intentionally left blank.

5

Page
204

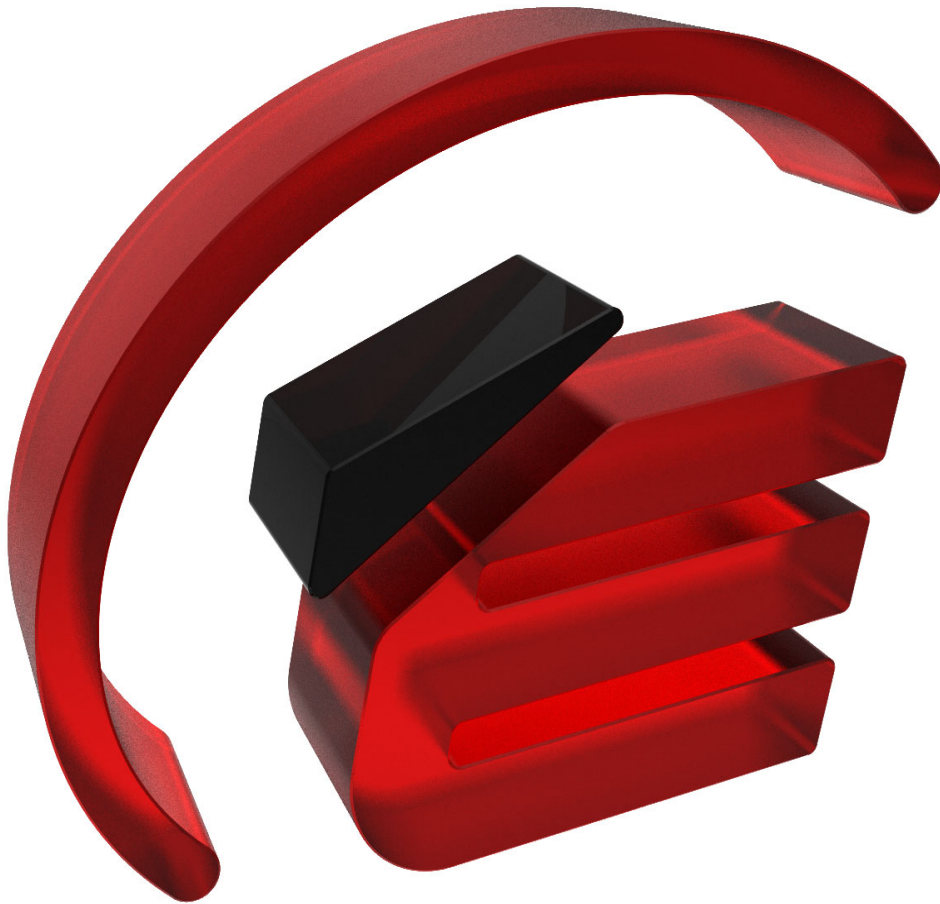



Product Summary	210
NW fittings	211
ISO fittings	223
CF Flange Fittings	230
Cord and Tubing	238
Oils, Fluids, Sealants and Greases	239
Vapour Pump Fluids	243
Greases and Waxes	245



- Fast availability from responsive local supply centers
- Edwards worldwide support
- International ISO, Pneurop and British Standards
- Complete range for all common sizes in aluminium and stainless steel
- Stainless fittings made in 316L for highest corrosion resistance
- Precision material control ensures low outgassing and dependable vacuum performance

When you buy flange fittings from Edwards, you can expect the service that only a leading international supplier can offer you. Whether you are an OEM (needing scheduled deliveries of component kits for series production) or a unique system builder, you can rely on your local supplier to meet all your requirements.

90+ Years of Vacuum Experience

From our experience in vacuum technology we enjoy solving your vacuum problems. You can rely on our library of vacuum applications and let us advise you on the most cost effective solutions. Our trained engineers will resolve any problem you have in choosing the right product for your application or troubleshooting a product that's not doing what you expected.

Partnership with Edwards

Edwards offers complete vacuum solutions. With our wide range of pumping technologies and sophisticated distribution networks we can offer flexible supply partnerships to match your competitive needs and offer the best value for your budget.

The Edwards Advantage

One Source Shopping

- Simplifies administration and purchasing costs
- Creates more purchasing power
- Ensures total quality performance

Kitting

- All components supplied for system build in one kit
- Simplifies ordering
- Ensures no missing parts in production
- Easier administration
- Reduces inventory levels, stock costs and warehousing space
- Easier control of usage

Consignment Stocks

- Only pay for when used
- Stocks on your premises
- No delivery problems
- Stocks regularly replenished when used

Total Quality

- Accredited ISO9001 supplier
- Customer contracts performance measures

Vacuum Fittings in General

Edwards vacuum fittings are designed to be leak-tight in vacuum applications. However, they are not intended to provide full structural support. When designing vacuum systems, it is essential that consideration be given to the static and dynamic loads imposed on each connection. If necessary, additional mechanical support should be provided.

Regular inspection including leak-checking and, where appropriate, periodic replacement of components should be considered.

These accessories are primarily designed for vacuum applications however some will withstand a small over-pressure, which is indicated in the tables below where appropriate. For the purpose of the European Union's Pressure Equipment Directive (97/23/EC), these items are considered to be piping for Group 2 gases (i.e. gas mixtures which are not explosive, flammable, toxic or oxidising) and are manufactured according to sound engineering practice as defined within the Directive.

NW and ISO Flange Fittings

Choose the optimum material to match your application and budget. Aluminium is ideal for achieving dependable cost-effective performance down to 10^{-7} mbar. Edwards also offers 316L/DIN 1.4404 stainless steel fittings for rugged corrosion resistance in semiconductor processing and excellent repeatability in high vacuum applications. In addition, careful quality control of elastomer specifications ensures critical sealing materials deliver the low outgassing performance your vacuum system performance depends on. Edwards attention to detail on all specifications delivers fit-and-forget dependability for your vacuum equipment.

UHV ConFlat® Flange Fittings

Sealing Principle A copper seal is squeezed axially and radially between two CF flanges, where knife-edges force the copper to cold flow. This flow is severely limited by the vertical flange wall which generates high pressures and fills surface imperfections to give a leak tight joint. At high bakeout temperatures, the flange geometry maintains high internal pressures despite softening of the gasket. A radial groove extends right up to the sealing ring and provides for leak testing of the vacuum connection.

Materials Our range of CF flanges is manufactured from AISI 304 stainless steel, which offers optimum performance at an affordable cost. Stainless steel 304 is used for the majority of UHV applications where a bakeout temperature of up to 450 °C is needed. AISI 316LN stainless steel is recommended for special applications where a harder material, higher bakeout temperature and much lower magnetic permeability are needed: these fittings are available on special order terms.

Dimensions Edwards CF flanges are manufactured to international standards and are compatible with all leading manufacturers. Metric flanges common in Europe and Asia use metric tapped holes and bored holes in flanges suitable for metric tubing. Flanges specified in inches, more commonly used in the USA, use UNF tapped flange threads and bored holes compatible with inch sized tube. Edwards offers both options.

CF Flange Names There are many descriptions used to describe the same flange sizes. Use the table below to cross-reference between common names.

CF Flange Name Equivalents				Flange OD		
				mm	inch	
DN16CF	NW16	CF34	NW16CF	1 1/8 inch	34.00	1.33
DN25CF			NW25CF	2 1/8 inch	53.60	2.11
DN40CF	NW35	CF70	NW35CF	2 3/4 inch	70.00	2.73
DN50CF			NW50CF	3 3/4 inch	85.70	3.37
DN63CF	NW63	CF114	NW63CF	4 1/2 inch	114.00	4.47
DN80CF			NW75CF	4 5/8 inch	117.35	4.62
DN100CF	NW100	CF150	NW100CF	6 inch	152.00	5.97
DN125CF			NW130CF	6 3/4 inch	171.45	6.75
DN160CF	NW150	CF200	NW150CF	8 inch	202.00	7.97
DN200CF	NW200	CF250	NW200CF	10 inch	253.00	9.97
DN250CF	NW250	CF300	NW250CF	12 inch	306.00	13.25

NW Polymer Clamping Rings



In addition to the traditional aluminium hinged clamp, Edwards also offers a range of coupling clamps manufactured from high technology polymer, offering important advantages for the vacuum system builder.

Compared to aluminium, the high flexural modulus and better strength-to-weight ratio has enabled Edwards to design and manufacture clamps which are lighter and more compact than existing aluminium products. The CX4 crystalline aryl polymer clamps can be used at temperatures up to 100 °C and are unaffected by most common solvents.

These clamps are competitively priced and the high quality finish will enhance the appearance of any vacuum system. The range is available in swing and quick release hinged versions covering the following flange sizes: NW10/16, 20/25, 25/32, 32/40 and 50. With Edwards Co-Seals, swing clamps are suitable for use in the pressure range 10⁻⁷ mbar to 10 bar. Electrical continuity across the clamps is achieved by built-in earth strips.

Co-Seal

The introduction of our Co-Seal represented a major advance in the method of sealing NW and ISO flange connections. Discerning users appreciate the benefits of a seal design which eliminates crevices and trapped volumes. Our NW Co-Seals with polymer carriers offer a more economical seal with even wider appeal.

A Co-Seal has a split outer ring, or carrier, which retains a moulded elastomer sealing ring. When fitted, the inner face of the Co-Seal is directly exposed to the vacuum system, eliminating any crevices or trapped volumes which can generate gas bursts and inhibit pump-down. Unlike the regular centring-ring and O-ring, the NW Co-Seal is fully restrained externally and is therefore suitable from 10⁻⁷ mbar to 10 bar. Available with either nitrile or fluoroelastomer seals.

For ISO bolted flanges, cut-outs around the external circumference of the Co-Seal are positioned so that the securing bolts centralise the Co-Seal precisely. For ISO collar flanges, claw clamps also centralise the seal and are themselves spaced around the flange by the cut-outs in the Co-Seal.

Centring Rings in High Technology Polymer

We complement our aluminium centring-rings with a range manufactured from a high-tech polymer. These centring-rings have a unique slotted design which prevents gas bursts. The CX2 polymer can be used at temperatures up to 100 °C and is unaffected by most common solvents. The material has an outgassing rate of 6.6 × 10⁻⁸ mbar l s⁻¹cm⁻² which makes it suitable for use in most vacuum systems, whilst giving additional benefits in terms of lower weight and cost.

Technical Data

Physical Data

Operating pressure range (absolute)	
C clamp and centring-ring	10 ⁻⁷ mbar – 1 bar / 14.5 psi
Stainless steel clamping ring and Co-Seal	10 ⁻⁷ mbar – 10 bar / 145 psi
Stainless steel clamp and metal seal	10 ⁻⁸ mbar – 3 bar / 44 psi
Stainless steel clamp and Co-Seal (all sizes)	10 ⁻⁷ mbar – 10 bar / 145 psi
Polymer and aluminium clamps and Co-Seal	
NW10 to NW25	10 ⁻⁷ mbar – 10 bar / 145 psi
NW40 to NW50	10 ⁻⁷ mbar – 10 bar / 145 psi
NW trapped O-ring	10 ⁻⁷ mbar – 10 bar / 145 psi
ISO trapped O-ring	10 ⁻⁷ mbar – 1 bar / 14.5 psi
O-ring and centring-ring (vacuum use only)	10 ⁻⁷ mbar – 1 bar / 14.5 psi
Bellows	10 ⁻⁷ mbar – 1 bar / 14.5 psi
Flexible pipelines*	10 ⁻⁷ mbar – 1.5 bar / 21 psi
Braided flexible pipelines*	10 ⁻⁷ mbar – 10 bar / 145 psi

* Depends on size

Operating Temperature

The maximum temperature for continuous operation with fluoroelastomer is 150 °C. It may be intermittently baked to 200 °C.

Polymer Co-Seal	-10 to 80 °C
Aluminium Co-Seal and nitrile seal	-10 to 100 °C
Aluminium Co-Seal and fluoroelastomer seal	-10 to 200 °C
Polymer centring-ring and nitrile O-ring	-10 to 100 °C
Polymer centring-ring and fluoroelastomer seal	-10 to 125 °C
Nitrile O-ring	-10 to 100 °C
Fluoroelastomer O-ring	-10 to 200 °C
Polymer clamp	
Constant vacuum use	-10 to 100 °C
Intermittent vacuum use	-10 to 125 °C
Stainless steel clamping ring	-10 to 125 °C
Aluminium swing/hinge clamp	-10 to 200 °C
Stainless steel clamp	-10 to 200 °C

Standards compliance

NW and ISO fittings	Pneurop 6606 (1981), ISO1609 (1986) DIN28403, DIN28404 ISO3669
---------------------	--

CF fittings

Stainless steel equivalents

AISI Number	German Steel Number	DIN Standard
304	1.4301	X5 CrNi 18 10
303	1.4305	X10 CrNi 5 18 9
304L	1.4306	X2 CrNi 19 10
301	1.4310	X12 CrNi 17 7
316	1.4401	X5 CrNiMo 18 10
316L	1.4404	X2 CrNiMo 17 13 2
316Ti	1.4571	X6 CrNiMoTi 17 12 2
321	1.4541	X10 CrNiTi 18 9

Chemical Resistance

This information is provided as a general guide only. Further guidance should be sought with respect to specific chemicals and their applications

Material	Generally Resistant To	Generally Attacked By
Nitrile		
Butadiene Acrylonitrile copolymer	Many hydrocarbons, fats, oils, greases, hydraulic fluids	Ozone, ketones, esters, aldehydes, chlorinated and nitro hydrocarbons
Neoprene		
Chloroprene polymer	Moderate chemicals and acids, ozone, oily fats, greases, many oils and solvents	Strong oxidizing acids and esters, ketones, chlorinated aromatic and nitro hydrocarbons
Fluoroelastomer		
Fluorocarbon polymer	All aliphatic, aromatic and halogenated hydrocarbons, acids, animal and vegetable fats	Ketones, low molecular weight esters and nitro containing compounds
Aluminium		
	Organic acids, fatty acids, freons, nitric acid	Strong acids, alkalis, chlorinated solvents, mercury
Stainless steel		
	Organic acids, alkalis, nitric acid. Sulphuric acid (10%)	Oxidizing chlorines, some organic acids, hydrochloric acid, hydrofluoric acid
Polymer		
Liquid crystal polymer	Organic acids, glycols, chlorinated solvents, ketones, mineral and oxidising acids, caustic solutions, freons	Sodium hydroxide, sulphuric acid (70%)

Dimensions

NW Dimensions

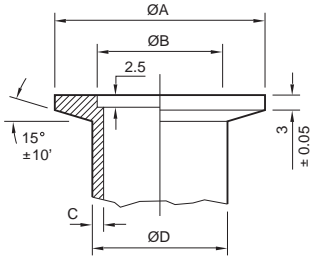

	A	B	C	D
NW10	30	12.2	2	14
NW16	30	17.2	2	20
NW20	40	22.2	2	25
NW25	40	26.2	2	28
NW32	55	34.2	2	38
NW40	55	41.2	2	44.5
NW50	75	52.2	2	57

ISO-K, ISO-F Dimensions

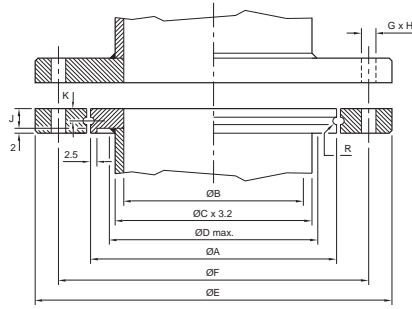

	A	B	C	D	E	F	G	H	J	K	R
ISO63	95	70	76.1	80	130	110	9	4	10	5	1.5
ISO80	110	83	88.9	95	145	125	9	8	10	5	1.5
ISO100	130	102	114.3	115	165	145	9	8	10	5	1.5
ISO160	180	153	160.3	165	225	200	11	8	10	5	2.5
ISO200	240	213	219	225	285	260	11	12	10	5	2.5
ISO250	290	261	273	275	335	310	11	12	10	5	2.5
ISO320	370	318	324	355	425	395	14	12	15	7.5	2.5
ISO400	450	400	406	435	510	480	14	16	15	7.5	4
ISO500	550	501	508	535	610	580	14	16	15	7.5	4
ISO630	690	630	660	660	750	720	14	20	20	10	5

CF dimensions

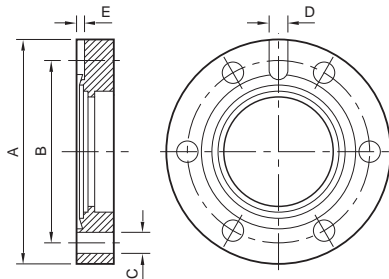

Nominal	A, mm	A, inch	B	C	D	E	Bolt Holes
DN16CF	34	1 1/8	27	4.4	-	-	6
DN40CF	70	2 3/4	58.7	6.6	-	-	6
DN63CF	114	4 1/2	92.1	8.4	6	3	8
DN100CF	152	6	130.2	8.4	6	3	16
DN160CF	202	8	181	8.4	6	3	20
DN200CF	253	10	231.8	8.4	6	3	24
DN250CF	306	12	284	8.4	6	3	32

ISO Flange Assembly with Co-Seals

Two Fixed Collar Flanges with Claw Clamps

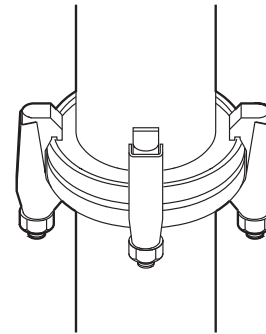

Two Rotatable Flanges

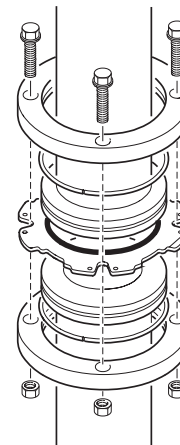

One Fixed Collar Flange, with One Rotatable Flange

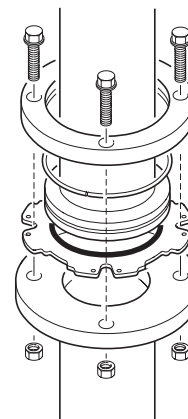

Product Summary

6

Page
210

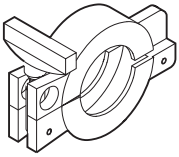

Description	Semiconductor				Features	Page		
	Scientific	R & D	Industrial			NW	ISO	CF
Clamps								
Clamping Ring	-	✓	✓	✓	Low cost, compact Stainless steel	6-6	-	-
Polymer Clamp	-	✓	✓	✓	Low cost, lightweight Neat appearance	6-6	-	-
Aluminium Clamp	✓	✓	✓	✓	Rugged Pneurop standard Competitive price	6-6	-	-
Metal Clamp	-	✓	✓	-	Suitable for aluminium and indium seals Wide temperature range	6-6	-	-
Claw Clamps and Bolts	✓	✓	✓	✓	Wide range optimised for many applications High strength CF bolts for UHV flanges	6-7	6-18	6-31

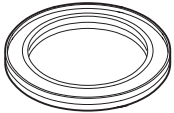

Seals								
Polymer Centring Ring	-	✓	✓	✓	Low cost Gas vents – no gas bursts Resistant to solvents	6-7	-	-
Trapped O-Rings	✓	✓	✓	✓	No gas bursts	6-9	6-19	-
Polymer Co-Seal	-	✓	✓	✓	No gas bursts Suitable for up to 10 bar	6-8	6-19	-
Metal Centring Ring	✓	✓	✓	✓	Stainless steel and aluminium carrier Pneurop standard Fluoroelastomer and nitrile versions	6-7	6-20	-
Metal Seal	-	✓	✓	-	Aluminium all metal seals Copper gaskets for UHV seals	6-9	-	6-30

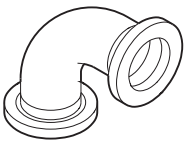

Pipeline Components								
Aluminium	-	✓	✓	✓	NW10 to NW50 components	6-9	6-21	-
Stainless Steel	✓	✓	✓	✓	NW10 to NW50 components NW and ISO fittings in 316L for corrosion resistance CF fittings in 304L for cost effectiveness	6-9	6-21	6-27

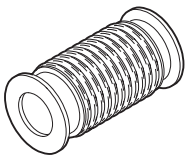

Bellows and Flexible Pipelines								
Bellows	✓	✓	✓	✓	NW and ISO fittings in 316L, CF fittings in 304L Suitable for minimising transfer of vibration from pump to vacuum systems	6-16	6-24	6-30
Flexible Pipelines	-	✓	✓	✓	Use to simplify connection of two components or correct misalignment Use braided versions for positive pressure applications (like dry pump exhausts)	6-16	6-24	-

NW fittings

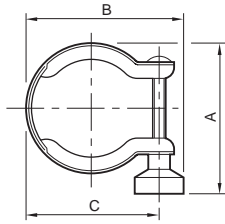

Size	A	B	C	D	E	F	Ordering Number
------	---	---	---	---	---	---	-----------------

Clamping Ring

Copper free (black wing nut)

NW10/16	44	46	34				C10512501
NW20/25	60	60	48				C10514501
NW32/40	73	75	63				C10516501
NW50	90	96	84				C10517501

Stainless steel (red wing nut)

NW10/16	44	46	34				C10512401
NW20/25	60	60	48				C10514401
NW32/40	73	75	63				C10516401
NW50	90	96	84				C10517401

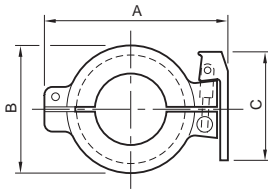

Hinged Clamp

aluminium

NW10/16	68	40	57				C10512402
NW20/25	80	50	57				C10514402
NW32/40	95	66	57				C10516402

Polymer

NW10/16	68	40	57				C10512303
NW20/25	80	50	57				C10514303
NW32/40	95	66	57				C10516303
NW50	125	86	57				C10517303

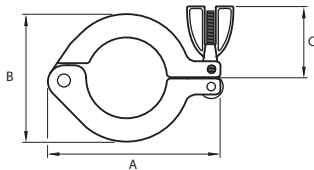

Swing Clamp

aluminium

NW10/16	62	40	35				C10512403
NW20/25	75	50	35				C10514403
NW32/40	90	66	35				C10516403
NW50	120	86	35				C10517403

Polymer

NW10/16	62	40	35				C10512304
NW20/25	75	50	35				C10514304
NW32/40	90	66	35				C10516304
NW50	120	86	35				C10517304

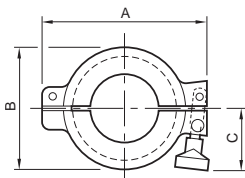

Clamp (Metal Seals)

Stainless steel

NW10/16	54	22					C10512404
NW20/25	64	32					C10514404
NW32/40	82	47					C10516404
NW50	112	62					C10517404

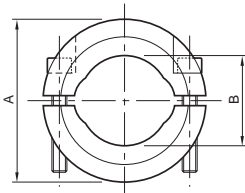

We recommend the use of thread lubricant, 1764 00030.

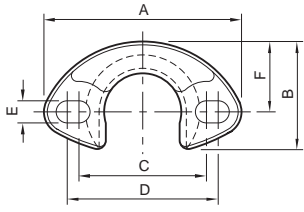

* Stainless steel; † Non slotted

Size	A	B	C	D	E	F	Ordering Number
"C" Clamp							
Nickel plated brass including screw pack							
NW10/16	59	35	38	45	6.3	22	C11002340
NW25	70	44	54	54†	8.3	25.4	C11004340
NW40*	100	73.5	79	81	8.3	50	C11005340

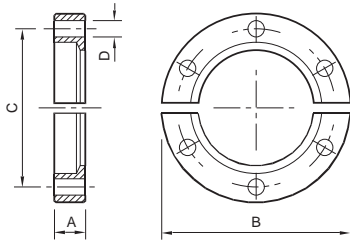

Bulkhead Clamp

aluminium

					Europe	N. America
NW10/16	9.2	50.8	38.1	5.1	C10512007	C90512007
NW25	9.8	60.3	48.0	5.1	C10514007	C90514007
NW40	9.3	74.6	62.0	5.1	C10516007	C90516007
NW50	10.3	95.2	83.0	5.1	C10517007	C90517007

All sizes supplied with
6 x 10-32 UNF x 5/8" hex head stainless steel bolts
6 x 10-32 UNF stainless steel plain washers

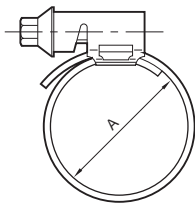

PVC Hose Clamp

Stainless steel

NW10/16	25	C10512408
NW25	36	C10514408
NW40	50	C10516408
NW50	60	C10517408

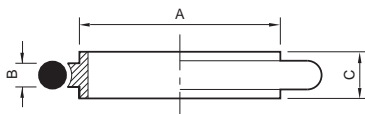

Centring Ring with O-Ring

Fluoroelastomer/stainless steel carrier

NW10	12	3.9	8	C10511395
NW16	17	3.9	8	C10512395
NW25	26	3.9	8	C10514395
NW40	41	3.9	8	C10516395
NW50	52	3.9	8	C10517395

Fluoroelastomer/aluminium carrier

NW10	12	3.9	8	C10511397
NW16	17	3.9	8	C10512397
NW25	26	3.9	8	C10514397
NW40	41	3.9	8	C10516397

Fluoroelastomer/polymer carrier

NW10	12	3.9	8	C10511394
NW16	17	3.9	8	C10512394
NW25	26	3.9	8	C10514394
NW40	41	3.9	8	C10516394

Nitrile/stainless steel carrier

NW10	12	3.9	8	C10511396
NW16	17	3.9	8	C10512396
NW25	26	3.9	8	C10514396
NW40	41	3.9	8	C10516396
NW50	52	3.9	8	C10517396

Size	A	B	C	D	E	F	Ordering Number
Nitrile/aluminium carrier							
NW10	12	3.9	8				C10511398
NW16	17	3.9	8				C10512398
NW25	26	3.9	8				C10514398
NW40	41	3.9	8				C10516398

Nitrile/polymer carrier							
NW10	12	3.9	8				C10511393
NW16	17	3.9	8				C10512393
NW25	26	3.9	8				C10514393
NW40	41	3.9	8				C10516393

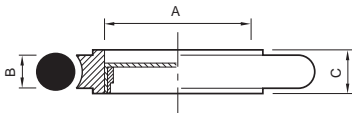

Centring Ring with Screen

Fluoroelastomer/stainless steel AISI 316L DIN 1.4404 Stainless Steel wire Ø0.5 Aperture size 1 mm²

NW16	9.5	3.9	8				C10512085
NW25	19.5	3.9	8				C10514085
NW40	32	3.9	8				C10516085
NW50	43	3.9	8				C10517085

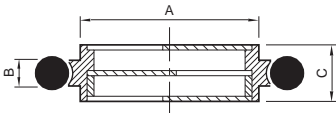

Centring Ring with Optical Baffle

Fluoroelastomer/stainless steel AISI 304L DIN 1.4301

NW25	26	3.9	8.5				D02110000
------	----	-----	-----	--	--	--	-----------

Centring Ring Sintered Filter

NW10							D02158020
NW40							D15405110

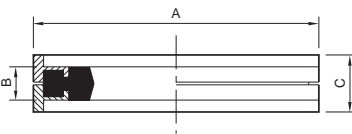

Co-Seal

Nitrile/aluminium carrier

NW10/16	32	3.9	7				B27158480
NW20/25	42	3.9	7				B27158490
NW32/40	57	3.9	7				B27158500

Nitrile/polymer carrier

NW10/16	32	3.9	7				B27158426
NW20/25	42	3.9	7				B27158447
NW32/40	57	3.9	7				B27158454
NW50	77.5	3.9	7				B27158467

Fluoroelastomer/aluminium carrier

NW10/16	32	3.9	7				B27158481
NW20/25	42	3.9	7				B27158491
NW32/40	57	3.9	7				B27158501

Fluoroelastomer/polymer carrier

NW10/16	32	3.9	7				B27158427
NW20/25	42	3.9	7				B27158448
NW32/40	57	3.9	7				B27158453
NW50	77.5	3.9	7				B27158466

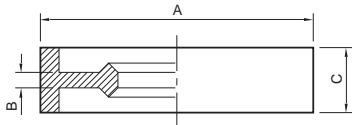

Size	A	B	C	D	E	F	Ordering Number
------	---	---	---	---	---	---	-----------------

Metal Seals

aluminium
Use with clamps (metal seals) C105-XX-404.

NW10/16	32	2.0	7				C27159004
NW20/25	42	2.0	7				C27159005
NW32/40	57	2.0	7				C27159006
NW50	77	2.0	7				C27159007

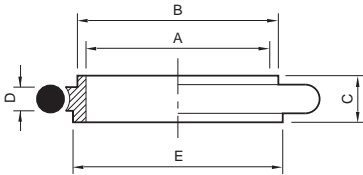

Adapting Centring Ring with O-Ring

Nitrile

NW10/16 stainless steel	10	12	8	3.9	17		C10512346
NW10/16 polymer	10	12	8	3.9	17		C10512349

Fluoroelastomer

NW10/16 stainless steel	10	12	8	3.9	17		C10512345
NW10/16 polymer	10	12	8	3.9	17		C10512350

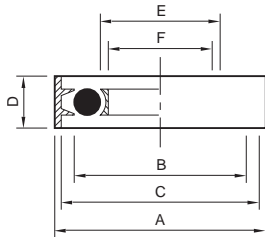

NW Trapped O-Ring

Fluoroelastomer/stainless steel/aluminium

NW10/16	32.5	27.5	30.2	7	18.5	16	C10512490
NW25	42.5	37.5	40.2	7	28.5	25	C10514490
NW40	57.5	52.0	55.2	7	43	40	C10516490
NW50	77.5	64.5	75.2	7	55.5	50	C10517490

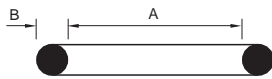

O-Ring (Pack of 10)

Nitrile

NW10	15	5					H02124012
NW16	18	5					H02124013
NW25	28	5					H02124015
NW40	42	5					H02124017
NW50	50	5					H02124018

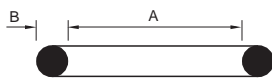

O-Ring (Pack of 5)

Fluoroelastomer

NW10	15	5					H02124032
NW16	18	5					H02124033
NW25	28	5					H02124035
NW40	42	5					H02124037
NW50	50	5					H02124038

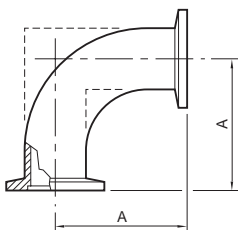

▲ Dimensions shown dotted in diagram

Elbow 90°

aluminium BS LM25 DIN 3.2371▲

NW10	30						C10511410
NW16	40						C10512410
NW25	50						C10514410
NW40	65						C10516410

Stainless Steel AISI 316L DIN 1.4404

NW10	30						C10511420
NW16	40						C10512420
NW25	50						C10514420
NW40	65						C10516420
NW50	70						C10517420

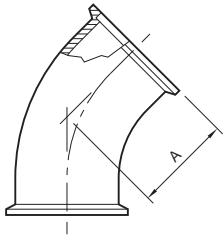

Size	A	B	C	D	E	F	Ordering Number
Elbow 45°							
Stainless Steel AISI 316L DIN 1.4404							
NW16	23.2						C10512405
NW25	28.5						C10514405
NW40	42.7						C10516405
NW50	50.6						C10517405

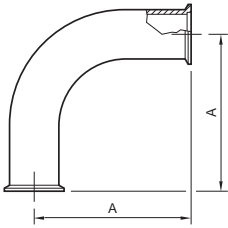

Long Radius Elbow							
Stainless Steel AISI 316L DIN 1.4404							
NW40	130						C10516406
NW50	140						C10517406

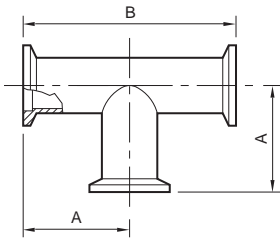

T-Piece							
aluminium BS LM25 DIN 3.2371							
NW10	30	60					C10511411
NW16	40	80					C10512411
NW25	50	100					C10514411
NW40	65	130					C10516411

Stainless Steel AISI 316L DIN 1.4404							
NW10	30	60					C10511421
NW16	40	80					C10512421
NW25	50	100					C10514421
NW40	65	130					C10516421
NW50	70	140					C10517421

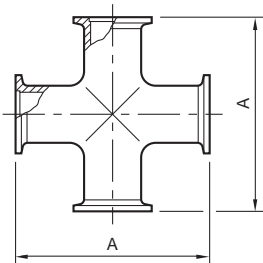

Cross Piece							
aluminium BS LM25 DIN 3.2371							
NW10	60						C10511412
NW16	80						C10512412
NW25	100						C10514412
NW40	130						C10516412

Stainless Steel AISI 316L DIN 1.4404							
NW10	60						C10511422
NW16	80						C10512422
NW25	100						C10514422
NW40	130						C10516422
NW50	140						C10517422

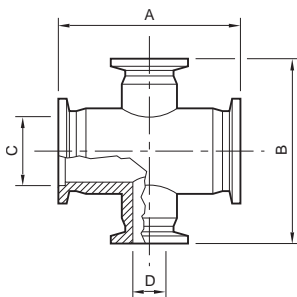

Reducing Cross							
aluminium ISO 6082 DIN 3.2315							
NW25/10	70	70	26.2	12.2			C10514413
NW40/10	80	90	41.2	12.2			C10516413

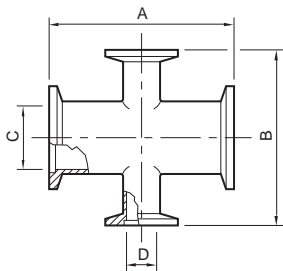

Size	A	B	C	D	E	F	Ordering Number
Reducing Cross							
Stainless Steel AISI 316L DIN 1.4404							
NW25/10	70	70	26.2	12.2			C10514423
NW25/16	100	80	26.2	17.2			C10514424
NW40/16	130	80	41.2	17.2			C10516424
NW40/25	130	100	41.2	26.2			C10516425
NW50/25	140	100	52.2	26.2			C10517425

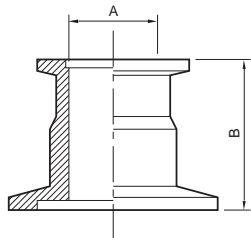

Size	A	B	Ordering Number
Reducing Piece			
aluminium ISO 6082 DIN 3.2315			
NW25/10	10	40	C10514436
NW25/16	16	40	C10514437
NW40/25	24	40	C10516439
NW40/16	16	40	C10516438
NW50/16	16	40	C10517040
NW50/25	24	40	C10517043
NW50/40	41	40	C10517041

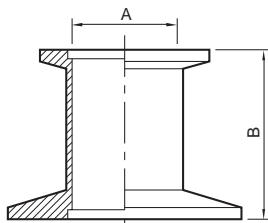

Size	A	B	Ordering Number
Reducing Piece			
Stainless Steel AISI 316L DIN 1.4404			
NW25/10	10	40	C10514446
NW25/16	16	28	C10514447
NW40/16	16	28	C10516448
NW40/25	24	28	C10516449
NW50/16	16	28	C10517450
NW50/25	24	40	C10517051
NW50/40	40	28	C10517452

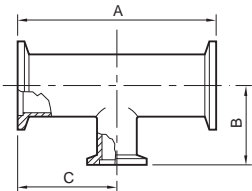

Size	A	B	C	Ordering Number
Reducing T-Piece				
Stainless Steel AISI 316L DIN 1.4404				
NW25/16	100	40	50	C10514427
NW40/16	130	40	65	C10516428
NW40/25	130	50	65	C10516429
NW50/16	140	50	70	C10517430
NW50/25	140	65	70	C10517431

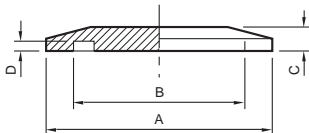

Size	A	B	C	D	Ordering Number
Blanking Flange					
aluminium BS LM 25 DIN 3.2371					
NW10	30	12.2	6	2.5	C10511368
NW16	30	17.2	6	2.5	C10512368
NW25	40	26.2	6	2.5	C10514368
NW40	55	41.2	6	2.5	C10516368
Stainless Steel AISI 316L DIN 1.4404					
NW10	30	12.2	6	2.5	C10511366
NW16	30	17.2	6	2.5	C10512366
NW25	40	26.2	6	2.5	C10514366
NW40	55	41.2	6	2.5	C10516366
NW50	75	52.2	6	2.5	C10517366

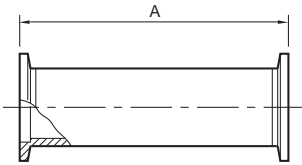

Size	A	B	C	D	E	F	Ordering Number
------	---	---	---	---	---	---	-----------------

Full Nipple

aluminium BS LM 25 DIN 3.2371

NW10	60						C10511409
NW16	80						C10512409
NW25	100						C10514409
NW40	130						C10516409

Stainless Steel AISI 316L DIN 1.4404

NW10	60						C10511433
NW16	80						C10512433
NW25	100						C10514433
NW40	130						C10516433
NW50	140						C10517433

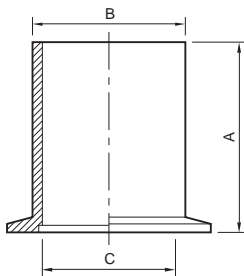

For inch tube: D= tube OD

Long Flange Weld Stub

Stainless Steel AISI 316L DIN 1.4404

For metric tube

NW10	70	15	10				C10511316
NW16	70	20	16				C10512316
NW25	70	28	24				C10514316
NW40	70	44.5	41				C10516616
NW50	70	57	51				C10517316

For inch tube

NW10	40	12.7	9.3	1/2			C10504080
NW16	40	19.1	15.7	3/4			C10504101
NW25	40	25.4	22	1			C10504223
NW40	40	38.1	34.7	1 1/2			C10504324
NW50	40	50.8	47.4	2			C10504351

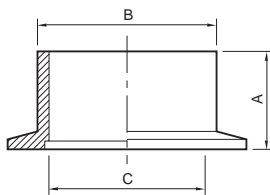

For inch tube: D= tube OD

Short Flange Weld Stub

Stainless Steel AISI 316L DIN 1.4404

For metric tube

NW10	30	15	10				C10511311
NW16	30	20	16				C10512311
NW25	30	28	24				C10514311
NW40	30	44.5	41				C10516611
NW50	30	57	51				C10517311

For inch tube

NW10	12.7	12.7	9.3	1/2			C10504079
NW16	12.7	19.1	15.7	3/4			C10504100
NW25	12.7	25.4	22	1			C10504222
NW40	19.1	38.1	34.7	1 1/2			C10504323
NW50	19.1	50.8	47.4	2			C10504350

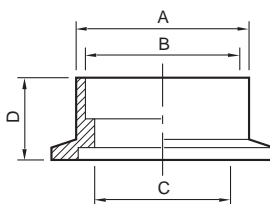

E= tube OD, mm
F= tube OD, inches

Weld Socket Flange for Inch Tube

Stainless Steel AISI 316L DIN 1.4404

NW16	15.5	13	11.4	12.7	12.7	1/2	C10504102
NW16	22.1	19.3	17.3	12.7	19.1	3/4	C10504103
NW25	28.6	25.9	22.1	12.7	25.4	1	C10504224
NW40	44.5	38.6	34.9	12.7	38.1	1 1/2	C10504325
NW50	57.2	51.3	47.5	12.7	50.8	2	C10504353

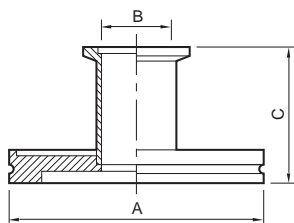

Size	A	B	C	D	E	F	Ordering Number
Adaptor NW/ISO							
Stainless Steel AISI 316L DIN 1.4404							
NW25/ISO63	95	25	50				C10007115
NW40/ISO63	95	40	50				C10007116
NW40/ISO80	110	40	118				C10008002
NW40/ISO100	130	40	50				C10009122
NW50/ISO63	95	50	50				C10007118
NW50/ISO80	110	50	118				C10008003
NW50/ISO100	130	50	50				C10009123

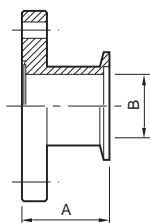

Adaptor NW/CF							
Stainless Steel AISI 316L DIN 1.4404							
NW16/DN16CF/1½	52.7	15.8					C10503104
NW16/DN40CF/2¾	45.3	15.8					C10503105
NW25/DN40CF/2¾	45.3	22					C10503207
NW40/DN40CF/2¾	45.3	40					C10503305
NW50/DN63CF/4½	49.5	50					C10503405

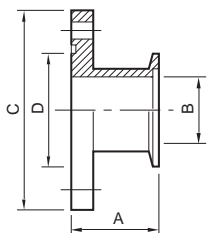

Adaptor NW/ASA with O-Ring Groove							
Stainless Steel AISI 316L DIN 1.4404							
NW40/2 inch ASA	46	40	152	86.9			C10503310
NW40/3 inch ASA	46	40	190	118			C10503311
NW50/2 inch ASA	46	50	152	86.9			C10503410

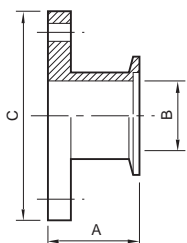

Adaptor NW/ASA without O-Ring Groove							
Stainless Steel AISI 316L DIN 1.4404							
NW40/1½ inch ASA	46	40	127				C10503303
NW40/2 inch ASA	46	40	152				C10503300
NW50/2 inch ASA	46	50	152				C10503400

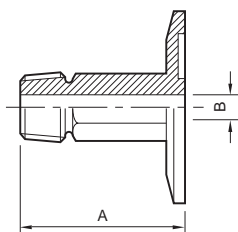

Adaptor NW/NPT Threaded Pipe Male							
Stainless Steel AISI 316L DIN 1.4404							
NW16/⅛ inch NPT male	40	4.7					C10501102
NW16/¼ inch NPT male	50	7.1					C10501103
NW25/⅛ inch NPT male	40	4.7					C10501217
NW25/¼ inch NPT male	50	7.1					C10501218
NW25/½ inch NPT male	75	11.9					C10501219
NW25¾ inch NPT male	75	15.9					C10501220
NW40/¼ inch NPT male	50	7.1					C10501303
NW40/½ inch NPT male	75	11.9					C10501304
NW40¾ inch NPT male	75	15.9					C10501305
NW40/1 inch NPT male	75	22.2					C10501306
NW50/½ inch NPT male	75	11.9					C10501501
NW50/1 inch NPT male	75	22.2					C10501503

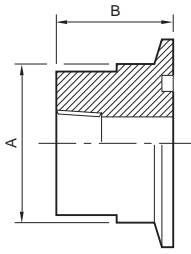

Size	A	B	C	D	E	F	Ordering Number
Adaptor NW/NPT Threaded Pipe Female							
aluminium ISO 6082 DIN 3.2315							
NW10 ¹ / ₈ inch NPT female	15.8	19.1					C10501070
NW16 ¹ / ₈ inch NPT female	15.8	19.1					C10501104
NW25 ¹ / ₈ inch NPT female	22.4	19.1					C10501221
NW40 ¹ / ₈ inch NPT female	31.8	25.4					C10501307
NW10 ¹ / ₄ inch NPT female	15.8	19.1					C10501071
NW16 ¹ / ₄ inch NPT female	15.8	19.1					C10501105
NW25 ¹ / ₄ inch NPT female	22.4	19.1					C10501222
NW40 ¹ / ₄ inch NPT female	31.8	25.4					C10501308

Stainless Steel AISI 316L DIN 1.4404							
NW10 ¹ / ₈ inch NPT female	15.8	19.1					C10501072
NW16 ¹ / ₈ inch NPT female	15.8	19.1					C10501106
NW25 ¹ / ₈ inch NPT female	22.4	19.1					C10501223
NW40 ¹ / ₈ inch NPT female	31.8	25.4					C10501309
NW10 ¹ / ₄ inch NPT female	15.8	19.1					C10501073
NW16 ¹ / ₄ inch NPT female	15.8	19.1					C10501107
NW25 ¹ / ₄ inch NPT female	22.4	19.1					C10501224
NW40 ¹ / ₄ inch NPT female	31.8	25.4					C10501310

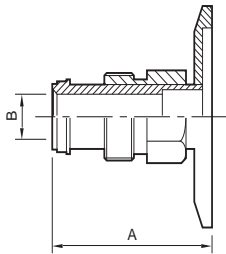

Adaptor NW/VCR Male							
Stainless Steel AISI 316L DIN 1.4404							
NW16 ¹ / ₄ inch VCR male	35.6	4.8					C10501108
NW16 ¹ / ₂ inch VCR male	41.4	10.4					C10501110
NW25 ¹ / ₄ inch VCR male	35.6	4.8					C10501225
NW25 ¹ / ₂ inch VCR male	40.6	10.4					C10501227
NW40 ¹ / ₄ inch VCR male	35.6	4.8					C10501311
NW40 ¹ / ₂ inch VCR male	40.6	10.4					C10501313
NW50 ¹ / ₄ inch VCR male	35.6	4.8					C10501508

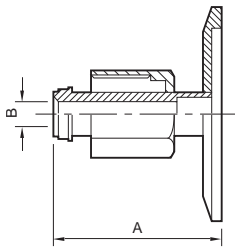

Adaptor NW/VCR Female							
Stainless Steel AISI 316L DIN 1.4404							
NW16 ¹ / ₄ inch VCR female	35.6	4.8					C10501109
NW16 ¹ / ₂ inch VCR female	41.4	10.4					C10501111
NW25 ¹ / ₄ inch VCR female	35.6	4.8					C10501226
NW25 ¹ / ₂ inch VCR female	40.6	10.4					C10501228
NW25 ³ / ₄ inch VCR female	54.4	15.7					C10501230
NW40 ¹ / ₄ inch VCR female	35.6	4.8					C10501312
NW40 ¹ / ₂ inch VCR female	40.6	10.4					C10501314

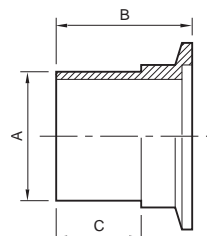

D= hose internal diameter

Adaptor PVC Hose							
Stainless Steel AISI 316L DIN 1.4404							
NW10 ¹ / ₂ inch hose	12.7	32	20	12.7			C10504081
NW16 ¹ / ₂ inch hose	12.7	32	20	12.7			C10504104
NW16 ³ / ₄ inch hose	19.1	32	20	19.1			C10504105
NW25 ³ / ₄ inch hose	19.1	38.1	26	19.1			C10504266
NW25 ¹ inch hose	25.4	38.1	26	25.4			C10504225
NW40 ¹ / ₂ inch hose	38.1	50	38.1	38.1			C10504326
NW50 ¹ / ₂ inch hose	47.4	55	41	50.8			C10504352

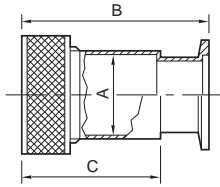

D= tube od in mm
E= tube OD in inches

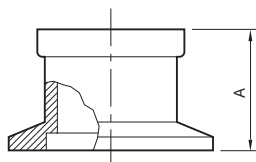
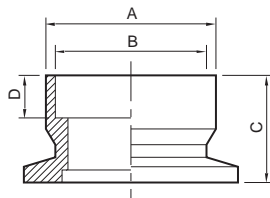
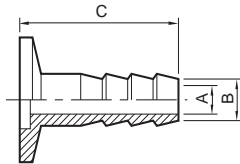
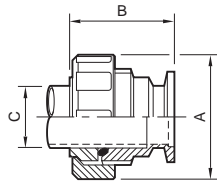

Temperature range -40 to 380 °C,
Temperature gradient <3 °C min⁻¹

Size	A	B	C	D	E	F	Ordering Number
------	---	---	---	---	---	---	-----------------

Gauge Tube Adaptor and Compression O-Ring

Stainless Steel AISI 316L DIN 1.4404 Fluoroelastomer O-ring

NW10	13.1	50	33	12.7	½		C10502001
NW16	6.7	32	–	6.4	¼		C10502101
NW16	13.1	50	33	12.7	½		C10502102
NW16	19.4	56	40	19.1	¾		C10502103
NW25	13.1	50	33	12.7	½		C10502201
NW25	19.4	58	40	19.1	¾		C10502202
NW25	25.8	62	46	25.4	1		C10502203
NW40	13.1	58	33	12.7	½		C10502300
NW40	19.4	63.5	40	19.1	¾		C10502301
NW40	25.8	71	46	25.4	1		C10502302
NW40	29	74	49	28.6	1⅛		C10502303
NW40	38.4	84	63.5	38.1	1½		C10502304
NW50	19.4	63.5	40	19.1	¾		C10502400
NW50	25.8	71	46	25.4	1		C10502401
NW50	51.1	87	66	50.8	2		C10502404

Compression Fitting

aluminium

NW10	44	43	14/15				C10520050
------	----	----	-------	--	--	--	-----------

Nozzle

aluminium ISO 6082 DIN 3.2315

NW10	7	12	40				C10511645
NW25	7	12	40				C10514645
NW40	7	12	40				C10516645

Coupling Body

Brass

NW10	18	15.2	13	6			C10511328
NW25	32	28.2	20	8			C10514328
NW40	46	42.2	18	8			C10516628

NW Optical Viewpoint

Body: Stainless Steel AISI 316L DIN 1.4404; Mounting: Nilo K; Glass: Borosilicate (8250 Schott)

NW40	23.6						C10516407
NW50	31.8						C10517407

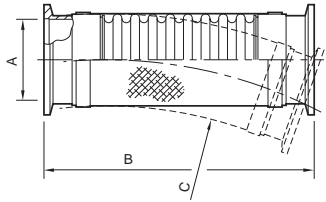

C= minimum bend radius, static
 D= minimum bend radius, dynamic
 E= maximum operating pressure, bar absolute

Size	A	B	C	D	E	F	Ordering Number
Braided Flexible Exhaust Pipeline							
Stainless Steel AISI 316L DIN 1.4404							
NW25	26.2	135	50	320	10.0		C10514294
NW40	41.2	135	80	400	10.0		C10516294
NW50	52.2	135	100	450	10.0		C10517294
NW25	26.2	250	50	320	10.0		C10514295
NW40	41.2	250	80	400	10.0		C10516295
NW50	52.2	250	100	450	10.0		C10517295
NW25	26.2	500	50	320	10.0		C10514296
NW40	41.2	500	80	400	10.0		C10516296
NW50	52.2	500	100	450	10.0		C10517296
NW25	26.2	1000	50	320	10.0		C10514297
NW40	41.2	1000	80	400	10.0		C10516297
NW50	52.2	1000	100	450	10.0		C10517297

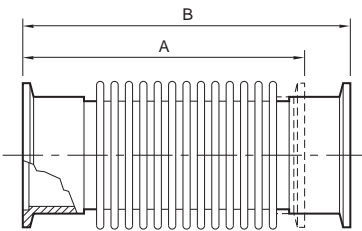

C= maximum operating pressure, bar absolute

Size	A	B	C	Ordering Number
Flexible Bellows				
Stainless Steel AISI 316L DIN 1.4404				
NW10	102	123	1.2	C10511670
NW16	102	123	1.2	C10512670
NW25	102	123	1.2	C10514670
NW40	102	123	1.2	C10516670
NW50	102	123	1.2	C10517670

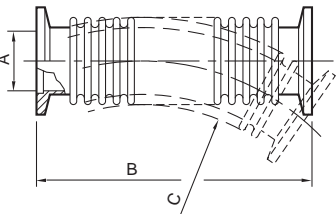

C= minimum bend radius, static
 D= minimum bend radius, dynamic
 E= maximum operating pressure, bar absolute

Size	A	B	C	D	E	F	Ordering Number
Flexible Pipelines							
Stainless Steel AISI 316L DIN 1.4404							
NW10	12.2	250	30	100	1.5		C10511285
NW16	17.2	250	30	130	1.5		C10512285
NW25	26.2	250	50	210	1.5		C10514285
NW40	41.2	250	80	260	1.5		C10516285
NW50	52.2	250	100	320	1.5		C10517285
NW10	12.2	500	30	100	1.5		C10511286
NW16	17.2	500	30	130	1.5		C10512286
NW25	26.2	500	50	210	1.5		C10514286
NW40	41.2	500	80	260	1.5		C10516286
NW50	52.2	500	100	320	1.5		C10517286
NW10	12.2	750	30	100	1.5		C10511300
NW16	17.2	750	30	130	1.5		C10512300
NW25	26.2	750	50	210	1.5		C10514300
NW40	41.2	750	80	260	1.5		C10516300
NW50	52.2	750	100	320	1.5		C10517300
NW10	12.2	1000	30	100	1.5		C10511287
NW16	17.2	1000	30	130	1.5		C10512287
NW25	26.2	1000	50	210	1.5		C10514287
NW40	41.2	1000	80	260	1.5		C10516287
NW50	52.2	1000	100	320	1.5		C10517287

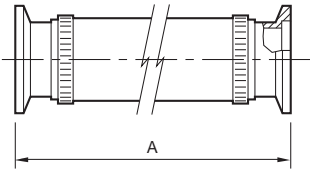

Size	A	B	C	D	E	F	Ordering Number
Reinforced PVC Tube with NW Flanges and Hose Clamps							
Stainless Steel AISI 316L DIN 1.4404							
NW10	500						C10511055
NW16	500						C10512055
NW25	500						C10514055
NW40	500						C10516055
NW50	500						C10517055
NW10	1000						C10511155
NW16	1000						C10512155
NW25	1000						C10514155
NW40	1000						C10516155
NW50	1000						C10517155

Maximum operating pressure 1 bar absolute, Temperature 5 to 60 °C

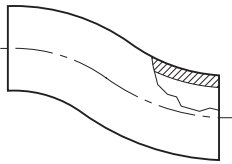

Reinforced PVC Tube, 1 metre

	Europe	N. America
½ inch ID tube	N/A	A63012220
¾ inch ID tube	H02100016	U30002173
1 inch ID tube	H02100017	A63012343
1½ inch ID tube	H02100018	U30000484
2 inch ID tube	H02100019	U30003837

Maximum operating pressure 1 bar absolute, Temperature 5 to 60 °C

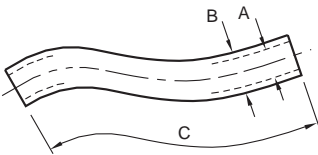

Neoprene Rubber Tube

5 x 19 mm	5	19	1000	H02100002
7 x 17 mm	7	17	1000	H02100003
9 x 25 mm	9	25	1000	H02100004
12 x 28 mm	12	28	1000	H02100005
20 mm x 34 mm	20	34	1000	H02100006
Reinforced hose	25	32	305	C06600025

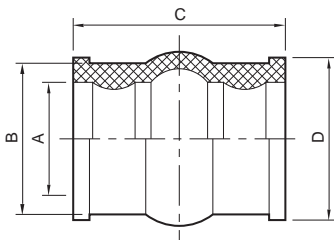

Moulded Sleeve

Neoprene							
NW10	13	21	38	23			C26501002
NW25	27	36	55	38			C26501004

ISO fittings

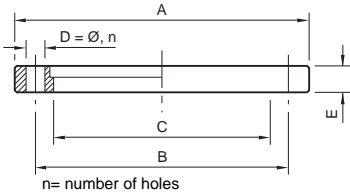

Size	A	B	C	D	E	F	Ordering Number
Rotatable Flange with Fitting Kit							
Mild steel nickel plated							
ISO63	130	110	95.5	Ø9,4	12		C10007010
ISO80	145	125	110	Ø9,8	12		C10008012
ISO100	165	145	130.5	Ø9,8	12		C10009010
ISO160	225	200	180.7	Ø11,8	16		C10011010
ISO200	285	260	240.7	Ø11,12	16		C10012010
ISO250	335	310	290.7	Ø11,12	16		C10013010
ISO320	425	395	371	Ø14,12	20		C10014012

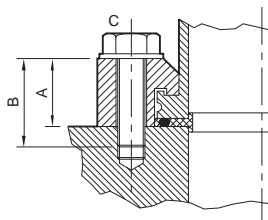

Half Claw Clamp for use with Centring Ring (Tapped Holes)							
Zinc plated mild steel body, stainless steel bolt							
ISO63	22.5	35	M8	4			C10007151
ISO100	22.5	35	M8	8			C10007151
ISO160	23	40	M10	8			C10011151
ISO200	23	40	M10	12			C10011151
ISO250	23	45	M10	12			C10011151
ISO320	36.5	60	M12	12			C10014151
ISO400	36.5	60	M12	16			C10014151
ISO500	36.5	60	M12	16			C10014151

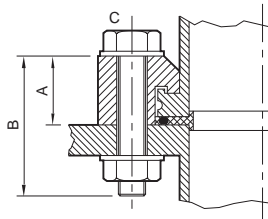

Half Claw Clamp for use with Centring Ring (Clear Holes)							
Zinc plated mild steel body, stainless steel bolt							
ISO63	22.5	35	M8	4			C10007150
ISO100	22.5	35	M8	8			C10007150
ISO160	23	40	M10	8			C10011150
ISO200	23	40	M10	12			C10011150
ISO250	23	45	M10	12			C10011150
ISO320	30.5	60	M12	12			C10014150
ISO400	30.5	60	M12	16			C10014150
ISO500	30.5	60	M12	16			C10014150

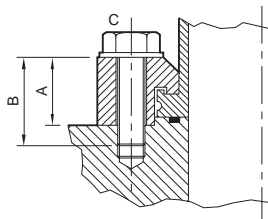

Half Claw Clamp for use with O-ring groove (tapped holes)							
Zinc plated mild steel body, stainless steel bolt							
ISO63	18.6	35	M8	4			C10007093
ISO100	18.6	35	M8	8			C10007093
ISO160	19	40	M10	8			C10011093
ISO200	19	40	M10	12			C10011093
ISO250	19	40	M10	12			C10011093
ISO320	31	50	M12	12			C10014093
ISO400	31	50	M12	16			C10014093
ISO500	31	50	M12	16			C10014093

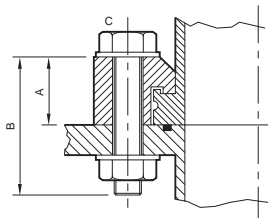

Half Claw Clamp for use with O-ring Groove (Clear Holes)							
Zinc plated mild steel body, stainless steel bolt							
ISO63	18.6	45	M8	4			C10007149
ISO100	18.6	45	M8	8			C10007149

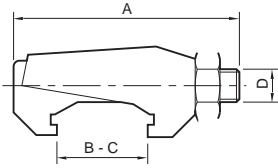

ISO63 requires 4 clamps; ISO80-160 requires 4-8 clamps; ISO200-320 requires 6-12 clamps; ISO400-500 requires 8-16 clamps

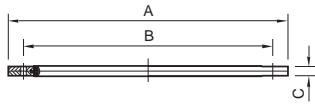
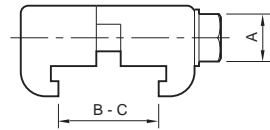

Use ISO polymer Co-Seals only for high vacuum applications $<10^{-6}$ mbar). In other applications, use the trapped O-ring seal; O-ring seals have higher mechanical strength.

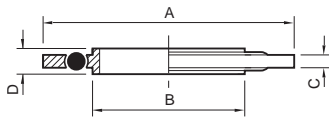

Size	A	B	C	D	E	F	Ordering Number
------	---	---	---	---	---	---	-----------------

Claw Clamps

Zinc plated 1.1181 steel

ISO63/ISO250	60	22	33	M10			C10007090
ISO320/ISO500	75	32	42	M12			C10014090

Claw Clamps

aluminium

ISO63/100	–	22	33	M8			C10007156
ISO160/250	–	24	38	M10			C10011094
ISO320/500	–	35	56	M12			C10014094

Co-Seal

Nylon, nitrile

ISO40	101	80	4.2				B27158458
ISO63	116	110	4.2				B27158063
ISO100	151	145	4.2				B27158070
ISO160	200	190	5.7				B27158073

Fluoroelastomer

ISO40	101	80	4.2				B27158457
ISO63	116	110	4.2				B27158064
ISO100	151	145	4.2				B27158071
ISO160	200	190	5.7				B27158074

Trapped O-Ring

aluminium centring-ring, aluminium outer ring

Fluoroelastomer

ISO63	95	70	3.9	8			C10521001
ISO100	128	102	3.9	8			C10523001
ISO160	179	153	3.9	8			C10524001

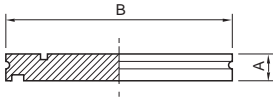

Size	A	B	C	D	E	F	Ordering Number
Blanking Flange for use with Collar Flange							
Stainless steel AISI 316L DIN 1.4404							
ISO63	12	95					C10007049
ISO80	12	110					C10008015
ISO100	12	130					C10009049
ISO160	12	180					C10011049
ISO200	12	240					C10012049
ISO250	12	290					C10013049
ISO320	17	370					C10014003
ISO500	17	550					C10016003

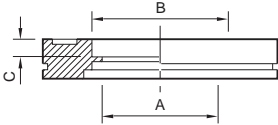

Size	A	B	C	D	E	F	Ordering Number
ISO Bored Flange							
Stainless steel AISI 316L DIN 1.4404							
ISO63	60.2	63.5	5.5				C10007138
ISO100	98.3	102	5.5				C10009157
ISO160	148	152	5.5				C10011068
ISO200	197	203	5.5				C10012053
ISO250	248	254	5.5				C10013059

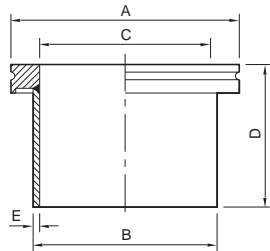

Size	A	B	C	D	E	F	Ordering Number
Collar Weld Stub							
Stainless steel AISI 316L DIN 1.4404							
ISO63	95	76	70	100	3.2		C10007032
ISO80	110	76	83	100	3.2		C10008013
ISO100	130	108	102	100	3.2		C10009032
ISO160	180	159	153	100	3.2		C10011032
ISO200	240	219.1	213	100	3.2		C10012032
ISO250	290	267	261	100	3.2		C10013032

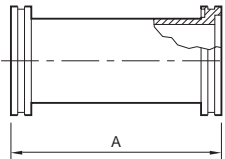

Size	A	B	C	D	E	F	Ordering Number
Nipple							
Stainless steel AISI 316L DIN 1.4404							
ISO63	176						C10007140
ISO100	216						C10009160
ISO160	276						C10011071
ISO200	356						C10012054
ISO250	416						C10013060

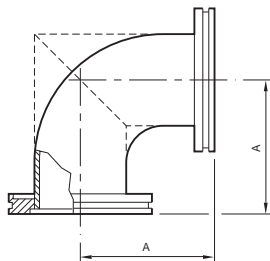

Size	A	B	C	D	E	F	Ordering Number
Elbow 90°							
Stainless steel AISI 316L DIN 1.4404							
ISO63	88						C10007203
ISO100	108						C10009203
ISO160*	138						C10011203
ISO200*	178						C10012203
ISO250*	208						C10013203

* Shown dotted

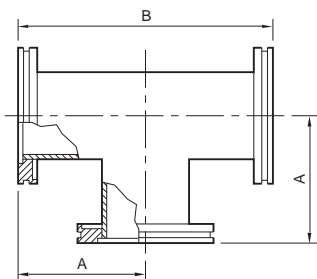

Size	A	B	C	D	E	F	Ordering Number
------	---	---	---	---	---	---	-----------------

T-piece

Stainless steel AISI 316L DIN 1.4404

ISO63	88	176					C10007207
ISO100	108	216					C10009207
ISO160	138	276					C10011207
ISO200	178	356					C10012207

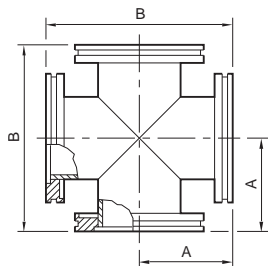

Cross Piece

Stainless steel AISI 316L DIN 1.4404

ISO63	88	176					C10007211
ISO100	108	216					C10009211

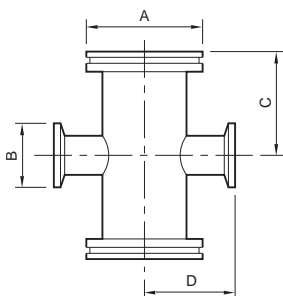

ISO to NW Reducing Cross

Stainless steel AISI 316L DIN 1.4404

ISO63/NW40	95	55	102	76			C10007232
ISO100/NW25	130	40	130	98			C10009231
ISO160/NW40	180	55	160	121			C10011232

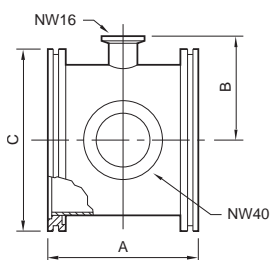

Connector with Two Lateral Flanges

Stainless steel AISI 316L DIN 1.4404

ISO63	88	60	95				C10007215
ISO100	108	75	130				C10009215
ISO160	138	100	180				C10011215

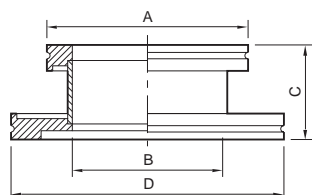

ISO/ISO Adapting Piece

Stainless steel AISI 316L DIN 1.4404

ISO80/ISO63	95	60	105	110	95		C10008021
ISO80/ISO100	110	73	105	130	110		C10009158
ISO100/ISO63	95	70	50	130	95		C10009111
ISO160/ISO63	95	70	50	180	95		C10011110
ISO160/ISO80	110	73	242	180	110		C10011069
ISO160/ISO100	130	102	50	180	130		C10011111

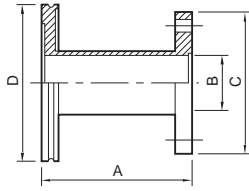

Supplied with bolts for tapped holes and bolts plus nuts and washers for plain holes

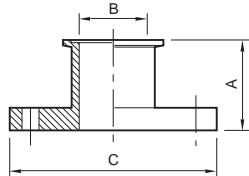
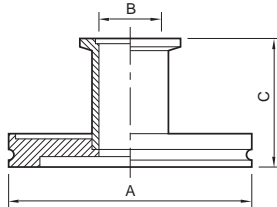

* Supplied with bolts for tapped holes and bolts plus nuts and washers for plain holes

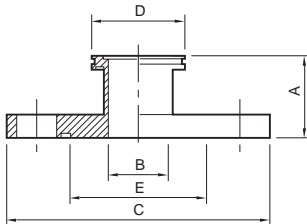
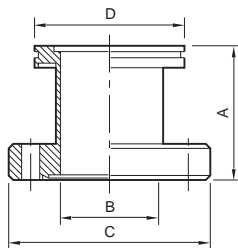

Size	A	B	C	D	E	F	Ordering Number
Adaptor ISO Bolted/ISO Collar							
Stainless steel AISI 316L DIN 1.4404							
ISO40 bolted/ISO63	106	41	100	95			C10007087
ISO63 bolted/ISO63	160	70	130	95			C10007155

Adaptor ISO/NW							
Stainless steel AISI 316L DIN 1.4404							
ISO63/NW25	95	25	50				C10007115
ISO63/NW40	95	40	50				C10007116
ISO100/NW40	130	40	50				C10009122
ISO63/NW50	95	50	50				C10007118
ISO80/NW50	110	50	118				C10008003
ISO100/NW50	130	50	50				C10009123
ISO80/NW40	110	40	118				C10008002

Adaptor ISO Bolted/NW							
Stainless steel AISI 316L DIN 1.4404							
					Europe	N. America	
ISO40 bolted/NW50*	50	41	100		C10005080	C10005080	
ISO40 bolted/NW40	69	40	100	No bolts supplied	N/A	A1516	
ISO63 bolted/NW50	50	50	130	No bolts supplied	N/A	A1509	
ISO63 bolted/NW40	68	40	130	No bolts supplied	N/A	A1448	
ISO63 bolted/NW40	50	40	130	No bolts supplied	N/A	A1574	
ISO40/ISO63 bolt kit for clear and tapped holes					N/A	NGV515000	

Adaptor ISO/CF							
Stainless steel AISI 316L DIN 1.4404							
ISO63/DN63CF/4½	110	60	114	95			C10007130
ISO100/DN100CF/6	111	98	152	130			C10009149
ISO100/DN160CF/8	113	148	203	180			C10011063

Adaptor ISO/ASA							
Stainless steel AISI 316L DIN 1.4404							
Without O-ring groove							
ISO63/2 inch ASA	106	60.2	152	95			C10007131
ISO80/3 inch ASA	106	72.9	190	110			C10008011
ISO100/3 inch ASA	106	98.3	190	130			C10009152
ISO100/4 inch ASA	106	98.3	229	130			C10009154
ISO160/6 inch ASA	112	148	279	180			C10011066

With O-ring groove							
ISO63/2 inch ASA	106	60.2	152	95	88.5		C10007132
ISO63/3 inch ASA	106	60.2	190	95	114.5		C10007134

Size	A	B	C	D	E	F	Ordering Number
------	---	---	---	---	---	---	-----------------

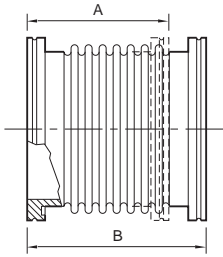

C= maximum pressure, bar absolute

Flexible Bellows

Stainless steel AISI 316L DIN 1.4404

ISO63	106	127	1.5				C10007670
ISO80	106	127	1.5				C10008028
ISO100	107	127	1.5				C10009670
ISO160	170	220	1.5				C10011670
ISO200	170	220	1.5				C10012670
ISO250	170	220	1.5				C10013670

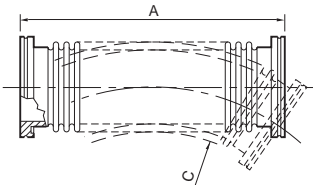

C= minimum band radius, static
D= minimum band radius, dynamic
E= maximum pressure, bar absolute

Flexible Pipelines

Stainless steel AISI 316L DIN 1.4404

ISO63	250	140	360	1.4			C10007285
ISO100	250	200	550	1.3			C10009285
ISO63	500	140	360	1.4			C10007286
ISO100	500	200	550	1.3			C10009286
ISO63	750	140	360	1.4			C10007288
ISO80	750	160	420	1.4			C10008024
ISO100	750	200	550	1.3			C10009288
ISO63	1000	140	360	1.4			C10007287
ISO100	1000	200	550	1.3			C10009287

Pump Hook-Up Kits



Pump hook-up kits are available as convenient boxed sets containing components, seals and clamps to connect pumps to mating flanges.

We offer a number of standard hook-up kits to simplify the installation of dry vacuum pumps.

Each kit has the required spool piece (if needed), bellows, seals and claw-clamps for direct connection of the dry pump to the appropriate size fore-line. All exhaust lines include NW40 braided flexibles.

Kits are available with gate valves and can include a dead leg to reduce particulates from falling directly into the pump inlet.

For greater protection, KIT714101 includes an ITO catchpot.

KIT715101 can be used with (but does not include) a Water Cooled Trap. Consult Edwards for more details.

Ordering Information

Product Description	Order No.
Straight inlet, no gate valve, 40 mm fore-line	KIT710040
Straight inlet, no gate valve, 50 mm fore-line	KIT710050
Straight inlet, no gate valve, 63 mm fore-line	KIT710063
Straight inlet, no gate valve, 100 mm fore-line	KIT710100
Straight inlet, pneumatic gate valve, 63 mm fore-line	KIT712064
Straight inlet, pneumatic gate valve, 100 mm fore-line	KIT712101
Dead-leg inlet, pneumatic gate valve, 100 mm fore-line	KIT713101
Catchpot, pneumatic gate valve, 100 mm fore-line	KIT714101
Dead-leg inlet, pneumatic gate valve, 100 mm fore-line for water cooled trap (not included)	KIT715101

CF Flange Fittings

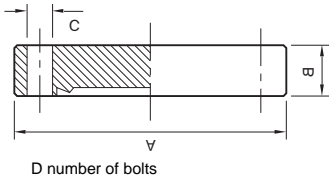

Size	A	B	C	D	E	F	Ordering Number
Blank Flange Non-Rotatable Clear							
Stainless steel AISI 304L DIN 1.4306							
Metric	Inch						
DN16CF	1 1/3	34	7.6	4.3	6		C10001200
DN40CF	2 3/4	70	12.7	6.7	6		C10005200
DN63CF	4 1/2	114	17.4	8.3	8		C10007400
DN100CF	6	152	19.9	8.3	16		C10009400
DN160CF	8	203	22.3	8.3	20		C10011300
DN200CF	10	254	24.6	8.3	24		C10012300

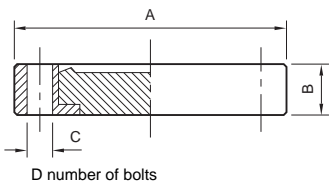

Size	A	B	C	D	E	F	Ordering Number
Blank Flange Rotatable Clear							
Stainless steel AISI 304L DIN 1.4306							
Metric	Inch						
DN16CF	1 1/3	34	7.6	4.3	6		C10001201
DN40CF	2 3/4	70	12.7	6.7	6		C10005201
DN100CF	6	152	19.9	8.3	16		C10009401

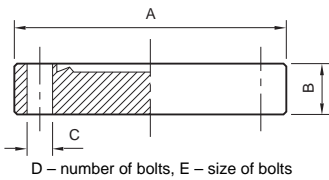

Size	A	B	C	D	E	F	Ordering Number
Blank Flange Non-Rotatable Tapped							
Stainless steel AISI 304L DIN 1.4306							
Metric	Inch						
DN16CF	1 1/3	34	7.6	4.3	6	M4	C10001202
DN40CF	2 3/4	70	12.7	6.7	6	M6	C10005202
DN63CF	4 1/2	114	17.4	8.3	8	M8	C10007402
DN100CF	6	152	19.9	8.3	16	M8	C10009402

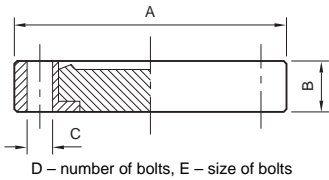

Size	A	B	C	D	E	F	Ordering Number
Blank Flange Rotatable Tapped							
Stainless steel AISI 304L DIN 1.4306							
Metric	Inch						
DN100CF	6	152	19.9	8.3	16	M8	C10009403
DN160CF	8	203	22.3	8.3	20	M8	C10011303

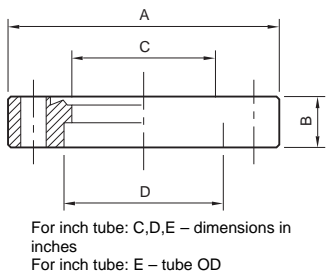

Size	A	B	C	D	E	F	Ordering Number
Bored Weld Flange Non-Rotatable Clear							
Stainless steel AISI 304L DIN 1.4306							
For metric tube							
Metric	Inch						
DN40CF	2 3/4	70	12.7	36.9	38.2		C10005207
DN40CF	2 3/4	70	12.7	40.1	41.3		C10005208
DN63CF	4 1/2	114	17.4	49.6	51.1		C10007405
DN100CF	6	152	19.9	99.4	101.9		C10009405
DN200CF	10	254	24.6	200.4	203.5		C10012305
For inch tube							
Metric	Inch						
DN63CF	4 1/2	114	17.4	1.875	2.01	2	C10007405
DN100CF	6	152	19.9	3.81	4.01	4	C10009405
DN200CF	10	254	24.6	7.812	8.02	8	C10012305

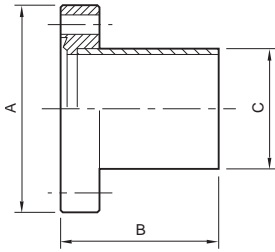

Size	A	B	C	D	E	F	Ordering Number
------	---	---	---	---	---	---	-----------------

Half-Nipple Non-Rotatable Clear

Stainless steel AISI 304L DIN 1.4306

Metric Inch

DN16CF	1 $\frac{1}{3}$	34	38	19			C10001250
DN40CF	2 $\frac{3}{4}$	70	63	38			C10005250
DN63CF	4 $\frac{1}{2}$	114	105	64			C10007450
DN100CF	6	152	135	102			C10009450
DN160CF	8	203	167	152			C10011450

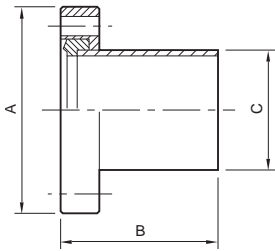

Half-Nipple Rotatable Clear

Stainless steel AISI 304L DIN 1.4306

Metric Inch

DN40CF	2 $\frac{3}{4}$	70	63	38			C10005251
DN63CF	4 $\frac{1}{2}$	114	105	64			C10007451
DN100CF	6	152	135	102			C10009451
DN160CF	8	203	167	152			C10011451

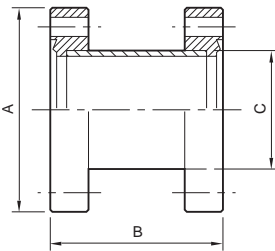

Full-Nipple Non-Rotatable Clear

Stainless steel AISI 304L DIN 1.4306

Metric Inch

DN40CF	2 $\frac{3}{4}$	70	126	38			C10005260
--------	-----------------	----	-----	----	--	--	-----------

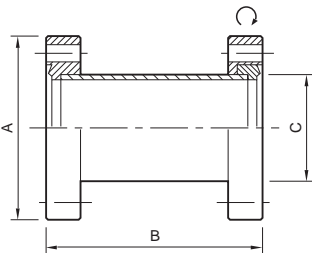

Full-Nipple Rotatable Clear

Stainless steel AISI 304L DIN 1.4306

Metric Inch

DN40CF	2 $\frac{3}{4}$	70	126	38			C10005261
DN63CF	4 $\frac{1}{2}$	114	210	64			C10007461
DN100CF	6	152	270	102			C10009461

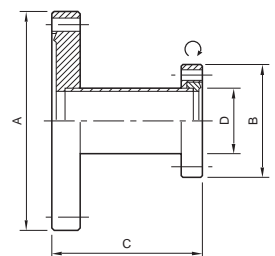

Reducing Nipple Rotatable Clear

Stainless steel AISI 304L DIN 1.4306

Metric Inch

DN40/16CF	2 $\frac{3}{4}$ /1 $\frac{1}{3}$	70	34	70	19		C10005370
DN63/40CF	4 $\frac{1}{2}$ /2 $\frac{3}{4}$	114	70	70	38		C10007570
DN100/40CF	6/2 $\frac{3}{4}$	152	70	70	38		C10009570

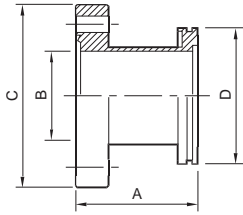

Size

A B C D E F

Ordering Number

Adaptors ISO/CF

Stainless steel AISI 316L DIN 1.4404

Metric/inch

ISO63/DN63CF/4½	110	60	114	95		C10007130
ISO100/DN100CF/6	111	98	152	130		C10009149
ISO160/DN160CF/8	113	148	203	180		C10011063

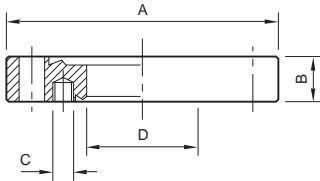

Zero Length Adaptor Major Clear/Minor Tapped

Stainless steel AISI 304L DIN 1.4306

Metric Inch

DN40/16CF	2¾/1⅓	70	12.7	M4	13.2	C10005240
DN63/40CF	4½/2¾	114	17.5	M6	36.9	C10007440
DN100/40CF	6/2¾	152	19.9	M6	36.9	C10009440
DN100/63CF	6/4½	152	19.9	M8	61.2	C10009441
DN63/40CF	4½/2¾	114	17.5	¼-28	36.9	C10007441

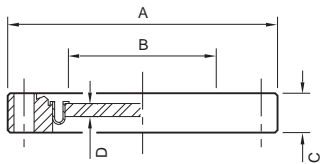

NW Zero Length Kodial Viewport

Stainless steel AISI 304L DIN 1.4306

Metric Inch

DN16CF	1⅓	34	16	12.7	1	C10001600
DN40CF	2¾	70	38	12.7	2.5	C10005600
DN63CF	4½	114	63	17.4	3	C10007600
DN100CF	6	152	89	19.9	4	C10009600
DN160CF	8	203	136	22.3	6.5	C10011600

Bakeable to 350 °C, at no greater than 2 to 3 °C per minute.
Use annealed copper gaskets.

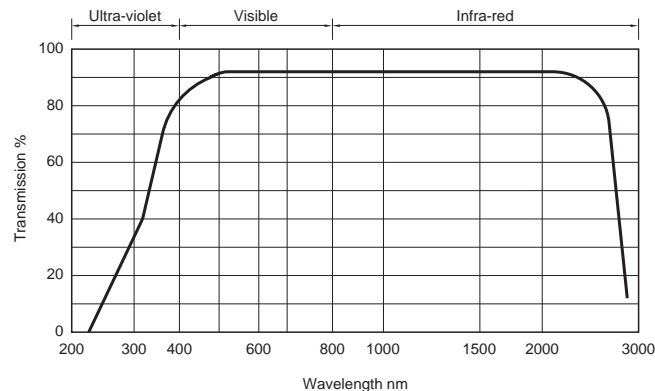

Kodial transmission curve

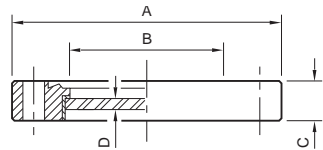

Bakeable to 200 °C, at no greater than 2 to 3 °C per minute.
Use annealed copper gaskets.

Size	A	B	C	D	E	F	Ordering Number
Zero Length Quartz Viewport							
Stainless steel AISI 304L DIN 1.4306							
Metric	Inch						
DN40CF	2¾	70	29.5	12.7	4		C10005610
DN63CF	4½	114	60	17.3	5		C10007610

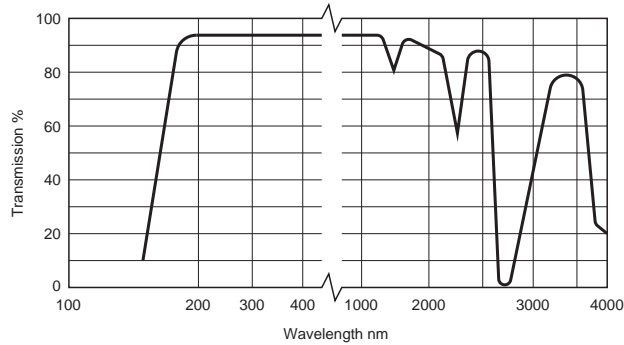

Quartz transmission curve.

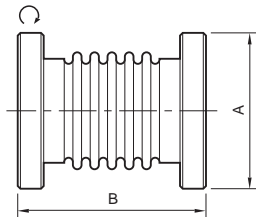

C – maximum pressure, bar absolute

Size	A	B	C	Ordering Number
Hydroformed Bellows Rotatable				
Stainless steel AISI 304L DIN 1.4306				
Metric	Inch			
DN16CF	1⅓	34	110	1.2
DN40CF	2¾	70	160	1.2

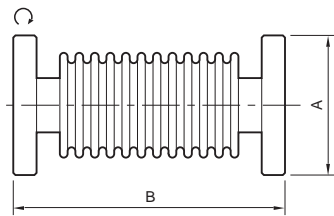

C – Minimum bend radius, static
D – Minimum bend radius, dynamic
E – Maximum pressure, bar absolute

Size	A	B	C	D	E	Ordering Number
Flexible Hose Rotatable						
Stainless steel AISI 304L DIN 1.4306						
Metric	Inch					
DN40CF	2¾	70	250	80	260	1.5
DN63CF	4½	114	250	140	360	1.5
DN16CF	1⅓	34	500	30	130	1.5
DN40CF	2¾	70	500	80	260	1.5
DN63CF	4½	114	500	140	360	1.5
DN100CF	6	152	750	200	550	1.5
DN40CF	2¾	70	1000	80	260	1.5
DN63CF	4½	114	1000	140	360	1.5

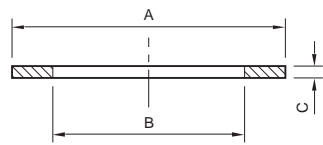

D – For flange OD, mm; E – For flange OD, inch
F – Number per pack

Size	A	B	C	D	E	F	Ordering Number
Copper Gaskets							
Metric	Inch						
DN16CF	1⅓	21	16	2	34	1.33	10
DN40CF	2¾	48	37	2	70	2.75	10
DN63CF	4½	82	63	2	114	4.5	10
DN100CF	6	120	101	2	152	6	10
DN160CF	8	171	152	2	203	8	5
DN200CF	10	222	203	2	254	10	5
DN250CF	12	270	254	2	304	12	5

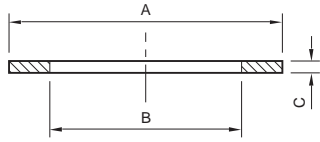

D – For flange OD, mm; E – For flange OD, inch
F – Number per pack

Size	A	B	C	D	E	F	Ordering Number	
Annealed Copper Gaskets								
Metric	Inch							
DN16CF	1 1/3	21	16	2	34	1.33	5	C10001270
DN40CF	2 3/4	48	37	2	70	2.75	5	C10005270
DN63CF	4 1/2	82	63	2	114	4.5	5	C10007270
DN100CF	6	120	101	2	152	6	5	C10009270
DN160CF	8	171	152	2	203	8	5	C10011270
DN200CF	10	222	203	2	254	10	5	C10012270
DN250CF	12	270	254	2	304	12	5	C10013270

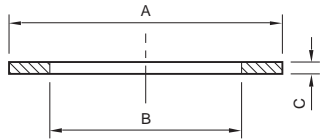

D – For flange OD, mm; E – For flange OD, inch
F – Number per pack

Size	A	B	C	D	E	F	Ordering Number	
Silver Plated Copper Gaskets								
Metric	Inch							
DN16CF	1 1/3	21	16	2	34	1.33	5	C10001280
DN40CF	2 3/4	48	37	2	70	2.75	5	C10005280
DN63CF	4 1/2	82	63	2	114	4.5	5	C10007280
DN100CF	6	120	101	2	152	6	5	C10009280
DN160CF	8	171	152	2	203	8	5	C10011280
DN200CF	10	222	203	2	254	10	5	C10012280

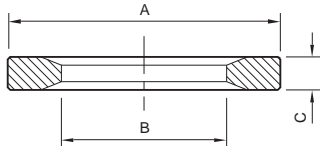

D – For flange OD, mm; E – For flange OD, inch
F – Number per pack

Size	A	B	C	D	E	F	Ordering Number	
Fluoroelastomer Gaskets								
Metric	Inch							
DN16CF	1 1/3	29	19	2	34	1.33	2	C10001620
DN40CF	2 3/4	50	38	3	70	2.75	2	C10005620
DN63CF	4 1/2	76	64	3	114	4.5	2	C10007620
DN100CF	6	112	100	3	152	6	2	C10009620
DN160CF	8	162	150	3	203	8	2	C10011620

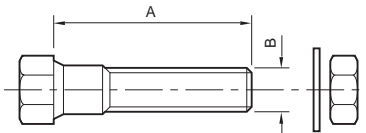

C – number per pack

Size	A	B	C	D	E	F	Ordering Number
HEX Head Nut, Bolt and Washers for Clear Hole CF Flanges							
Standard							
Metric	Inch						
DN16CF	1 1/3	20	M4	25			C10001630
DN40CF	2 3/4	35	M6	25			C10005630
DN63CF	4 1/2	45	M8	25			C10007630
DN100CF	6	50	M8	25			C10009630
DN160CF	8	60	M8	25			C10011630
DN200CF	10	60	M8	25			C10012630
DN40CF	2 3/4	35	1/4-28	25			C10005640
DN200CF	10	60	5/16-24	25			C10012640

Size	A	B	C	D	E	F	Ordering Number
Silver Plated							
Metric	Inch						
DN40CF	2 3/4	35	M6	25			C10005650
DN63CF	4 1/2	45	M8	25			C10007650
DN100CF	6	50	M8	25			C10009650
DN160CF	8	60	M8	25			C10011650
DN200CF	10	60	M8	25			C10012650

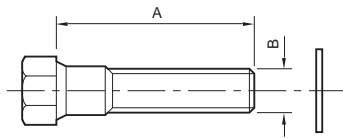

C – number per pack

Size	A	B	C	D	E	F	Ordering Number
------	---	---	---	---	---	---	-----------------

HEX Head Bolt and Washers for Tapped Hole CF Flanges

Standard

Metric	Inch	A	B	C	D	E	F	Ordering Number
DN40CF	2¾	25	M6	25				C10005670
DN63CF	4½	30	M8	25				C10007730

Silver Plated

Metric	Inch	A	B	C	D	E	F	Ordering Number
DN40CF	2¾	25	M6	25				C10005690
DN63CF	4½	30	M8	25				C10007690
DN100CF	6	35	M8	25				C10009690

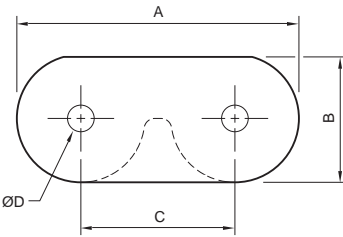

E – number per pack

Plate Nuts

Metric	Inch	A	B	C	D	E	F	Ordering Number
DN40CF	2¾	41	11	29	M6	25		C10005710
DN63CF	4½	51	12	35	M8	25		C10007710
DN40CF	2¾	41	11	29	¼-28	25		C10005720

Cord and Tubing

Lubrication All O-rings, nitrile rubber extruded cord and sheet used in low vacuum applications should be lubricated with either vapour pump fluid, Fomblin[®] vacuum grease or Apiezon[®] grease M. Lubrication will prolong the life of the material and facilitate sealing.

Apply the oil or grease very sparingly and evenly, coating the seal to give it no more than a shining surface with no visible smears.

Excessive lubrication may cause leaks.

In general, but with certain exceptions dictated by common sense, seals used in high vacuum applications should be lubricated, but even more sparingly, using vapour pump fluid.

Cleaning The only necessary and recommended method of cleaning O-rings and nitrile rubber extruded cord or sheet is by wiping with a dry, lint free, soft cloth. Most solvent fluids are liable to be absorbed by fluoroelastomer and nitrile rubber, swelling these materials and subsequently outgassing into the system.

Nitrile Rubber Cord

Nitrile cord should be cut perfectly square and to a length which is 5% above the mean circumference of the groove in which it is laid. Compression and sealing of the butt joint is thereby assured.

Ordering Information

Product Description	Order No.
Nitrile rubber cord	
0.275 inch (7 mm) diameter	H02101008
0.312 inch (8 mm) diameter	H02101009
0.500 inch (12.7 mm) diameter	H02101015

State exact length required (per metre).

Vacuum Tubing

This high quality neoprene rubber vacuum tubing is suitable for use down to approximately 10^{-4} mbar. We recommend that you use the shortest length possible.

Ordering Information

Product Description	Order No.
Rubber vacuum tube, 1 m lengths	
5 mm bore, 19 mm external diameter	H02100002
7 mm bore, 17 mm external diameter	H02100003
9 mm bore, 25 mm external diameter	H02100004
12 mm bore, 28 mm external diameter	H02100005
20 mm bore, 34 mm external diameter	H02100006
Flexible hose connection*	C06600025

* Neoprene, steel reinforced, 12 inch (305 mm) long, to suit 1½ inch external diameter tube

Oils, Fluids, Sealants and Greases



We strongly recommend that you use only the recommended grades and qualities of fluids and sealants, to maintain the high performance of Edwards products. If you use inferior materials, this can lead to a reduction in the pump or system efficiency, partial or complete failure of the equipment, and excessive outgassing. We think it is a false economy to use cheaper fluids and sealants which are untried for many demanding applications.

All our fluids and sealants are tested under formal laboratory conditions. In addition, we have gained considerable on-site experience through our own use of these materials and by maintaining close contact with users who have specific problems. As many cases of suspected equipment under-performance are eventually traced to the use of unsuitable or unsatisfactory fluids and sealants, we are pleased to advise on the correct selection of fluids and sealants for your application.

Mineral Based Materials

These materials include rotary pump oils, Diffstak and diffusion pump oils and greases. They are available with or without various additives for different applications.

Silicone Based Materials

These materials are used for Diffstak and diffusion pump fluids and greases. They comprise either di-methyl siloxanes or phenyl methyl siloxanes.

Synthetic-Organic Compounds

These include various hindered esters, phenyl ethers and naphthalene based compounds. They are offered for use in Diffstak and diffusion pumps, but they can also be used as a rotary pump oils in certain unique applications. Edwards can advise on the matching of the fluids to particular applications.

Fluorinated Materials (PFPE)

These are perfluoropolyethers. Perfluoropolyether is a fully fluorinated material free from other halogens and from hydrogen, and so is of particular value where freedom from hydrocarbons is important. It is inert to most reactive chemicals such as UF_6 , F_2 , O_2 , O_3 , and so on, and it does not polymerise when exposed to electron and most ion bombardment.

Perfluoropolyether fluid is available in grades suitable for use in rotary pumps. A low vapour pressure Fomblin[®] grease (AR555) is available which combines good lubrication properties with superior vacuum properties.

PFPE for Semiconductor Applications

The major growth in the use of perfluoropolyether (PFPE) compounds has been in applications where hostile process conditions quickly destroy normal hydrocarbon pump oils. This applies particularly in semiconductor processing. The corrosion resistant properties and chemical inertness of PFPE result in greatly increased operation times between oil changes and pump maintenance, and this provides a cost effective solution to many difficult pumping applications.

These are the basic properties of PFPE and the advantages for use in vacuum systems:

- **Chemically Inert** Ideal for pumping aggressive materials, particularly in semiconductor processes.
- **High Oxidation Resistance** Fluid is not damaged by repeated exposure to air at operating temperatures.
- **Non-Inflammable** No fire risk.
- **High Thermal Resistance** No residual tar compounds formed by overheating. Eventually reduced to gaseous products.
- **Oxygen Compatible** Allows absolutely safe pumping of oxygen (NASA approved for liquid oxygen systems). Maximum recommended operation temperature and pressure for 100% oxygen is 250 °C and 91.4 kg cm⁻² and 60 °C, 175.75 kg cm⁻².
- **Non-Polymerization** Does not polymerise on exposure to energetic particle bombardment (except hydrogen ions). This reduces the impact of backstreamed vapours, and is an important property where polymers cannot be tolerated (for example, in electron microscopes).
- **Miscible with Most Common Solvents** Allows pumping of solvent even without gas ballast.

Before charging with PFPE, thoroughly clean the pumps to achieve maximum advantage. If you do not have skilled technicians available, we recommend that you return the pumps to a Edwards Service Center to be cleaned and filled. Some models of high vacuum rotary pumps and mechanical booster pumps adapted for use with PFPE are available as standard and can be found in the appropriate sections of this catalogue: these pumps are assembled and tested with PFPE.

Safety note Perfluoropolyether is a fluorinated compound and will give-off toxic vapours if exposed to temperatures above 280 °C. Do not expose PFPE to naked flames and prohibit smoking in work areas.

Mechanical Pump Oils



Edwards supplies the widest range of oils of different viscosities and specifications to enable customers to obtain the best performance from mechanical pumps under different application conditions. Mineral oils are manufactured by a hydro treatment process to reduce carcinogenic risk. All are specially prepared for high vacuum use, having low vapour pressures even at high temperatures. The particular mechanical pump specification should be consulted to find which oil to use.

Ultragrade® Mineral Oils

Edwards offers a range of new oils, Ultragrade® 15, 19, 20 and 70, which result from a new process. Most manufacturers use a solvent refining process, whereas these oils are produced by a unique hydrotreating process. This process eliminates nitrogen, sulphur and oxygen and the aromatic hydrocarbons, leaving a clear base stock essentially free of impurities.

When combined with additives, the Ultragrade® oils give improved vacuum performance, thermal and oxidation stability and rust inhibition. The anti-oxidants included in the oils enable the pump to withstand high operating temperatures without oil degradation, so extending intervals between oil changes.

The properties of the oils allow them to be used in a wide range of applications. New Ultragrade® 70 oils are the best choice for large pumps used in heavy-duty, cycling applications. Contact Edwards or your local supplier for detailed recommendations.

Ultragrade Oil	Use In	Replaces
Ultragrade 15	E2M0.7, E2M1.5. Also suitable for cold start applications.	Edwards 8A
Ultragrade 19	RV pumps, E2M18	Supergrade A, Edwards 17 and 20
Ultragrade 70	E2M40 to E2M275	–
Ultragrade 20	EH boosters	Edwards 16 and 18

Ordering Information

Product Description	Order No.
Ultragrade 15	
1 litre	H11026015
12 x 1 litre	H11026012
4 litre	H11026013
4 x 4 litre	H11026011
205 litre	H11026010
Ultragrade 19	
1 litre	H11025015
12 x 1 litre	H11025012
4 litre	H11025013
4 x 4 litre	H11025011
205 litre	H11025010
Ultragrade 20	
1 litre	H11024015
12 x 1 litre	H11024012
4 litre	H11024013
4 x 4 litre	H11024011
205 litre	H11024010
Ultragrade 70	
4 litre	H11028013
4 x 4 litre	H11028011
205 litre	H11028010

Edwards TW has been developed for applications where rotary pump oils are likely to be exposed to reactive or corrosive gases. The oil is distilled hydrocarbon containing no additives, but unsaturates and aromatic links have been removed. The result is that the oil will last up to 20 times longer, depending on process, than refined mineral oils. Longer oil life significantly extends the intervals between oil changes.

Ordering Information

Product Description		Order No.	
		Europe	N. America
Edwards TW mineral oil	1 litre	H11012015	H02100001TW
	4 litre	H11012013	H02100002TW
	20 litre	H11012026	H02100003TW
	205 litre (55 US gal)	N/A	H02100004TW

Edwards 45 Oil

Edwards 45 is a hydrocarbon synthetic polymer whose molecular structure offers chemical inertness, high temperature stability and low vapour pressure (<10⁻⁷ mbar at 25 °C). It is commonly used in mass spectrometry applications because of its well defined peaks. Edwards 45 oil is non-toxic, non-corrosive and reclaimable.

Ordering Information

Product Description	Order No.	
	Europe	N. America
Edwards 45 oil		
1 litre	H11022015	H01800001
4 litre	H11022013	H01800003
12 x 1 litre	N/A	H01800005

V-Lube

The V-Lube range of oils offer good thermal stability and oxidation resistance and have been selected for use with the Stokes range of vacuum pumps. Choose from the following:

V-Lube Oil	Application
V-Lube B	-
V-Lube F	Microvac piston pumps
V-Lube G	Hot Microvac, 912H, 612MB
V-Lube H	MB Boosters

Ordering Information

Product Description	Order No.
V-Lube B oil	
3.8 litres (1 US gal) North America Only	254-117-001
19 litres (5 US gal) North America Only	254-539-001
208 litres (55 US gal) North America Only	297-854-001
V-Lube G oil	
19 litres (5 US gal) North America Only	262-461-003
208 litres (55 US gal) North America Only	421-793-001
V-Lube H oil	
3.8 litres (1 US gal) North America Only	424-051-001
19 litres (5 US gal) North America Only	419-699-001
208 litres (55 US gal) North America Only	419-698-001
V-Lube F oil	
5 litres (1.3 US gal)	H11030001
25 litres (6.6 US gal)	H11030002
205 litres (54 US gal)	H11030003
3.8 litres (1 US gal) North America only	254-117-002
19 litres (5 US gal) North America only	254-539-002
208 litres (55 US gal) North America only	254-780-001

Mechanical Pump Oil Selection Chart

Application	Ultra- grade 15	Ultra- grade 19	Ultra- grade 20	Ultra- grade 70	Edwards TW	Fomblin® 06/6	Krytox® 1506	Fomblin® 16/6	Krytox® 1514	Fomblin® 25/6	Krytox® 1525	
Mass spectrometers	•	•	•	•								
Electron microscopes	•	•	•	•								
Thin film sputtering	•	•	•	•								
Surface studies	•	•	•	•								
UHV systems	•	•	•	•								
Leak detection	•	•	•	•								
TV tubes		•	•	•								
Power valves		•	•	•								
Distillation		•	•	•	•							
Space studies		•	•	•								
Furnaces		•	•	•								
EB welders		•	•	•								
Semiconductors		•	•	•	•					•	•	
Impregnation		•	•	•								
Chemical pumping		•	•	•	•					•	•	
Oxygen pumping		•	•	•						•	•	
Radioactive		•	•	•						•	•	
Packaging		•	•	•								
Mechanical booster		•	•	•								
Metallisation		•	•	•				•				
vapour pressure mbar	5.8 x 10 ⁻⁶	1 x 10 ⁻⁸	2.1 x 10 ⁻⁷	2.1 x 10 ⁻⁷	1.3 x 10 ^{-6†}	4 x 10 ⁻⁶	5.2 x 10 ⁻⁷	3 x 10 ⁻⁶	2.6 x 10 ⁻⁷	4 x 10 ⁻⁸	1.3 x 10 ⁻⁷	
	3.0 x 10 ⁻²	1.0 x 10 ⁻³	3.0 x 10 ⁻³	3 x 10 ⁻³	–	5 x 10 ⁻³	1.3 x 10 ⁻³	1 x 10 ⁻³	1.3 x 10 ⁻⁴	6 x 10 ⁻⁵	3.9 x 10 ⁻⁵	
Molecular weight	385	420	500	600	430	1900	2400	2700	3500	3300	4600	
Specific gravity at 15 °C	0.86	0.86	0.86	0.86	0.860	1.88	1.88	1.89	1.89	1.9	1.9	
Viscosity cSt	104.2	143.7	352	222	155	64	70	168	140	276	250	
	at 20 °C	at 20 °C	at 20 °C	at 20 °C	at 20 °C	at 20 °C	at 20 °C	at 20 °C	at 20 °C	at 20 °C	at 20 °C	
	at 40 °C	at 40 °C	at 40 °C	at 40 °C	at 40 °C	at 40 °C	at 40 °C	at 40 °C	at 40 °C	at 40 °C	at 40 °C	
Pour point °C	-18	-16	-12	-12	-12	-50	-45	-45	-40	-35	-35	
Flash point °C	220	230	260	230	243	none*	none*	none*	none*	none*	none*	
Auto ignition point °C	355	355	365	360	270	none*	none*	none*	none*	none*	none*	
Sulphur content% mass/mass	0	0	0	0	0	0	0	0	0	0	0	
Energetic particle impact	Conducting polymers formed											
Thermal stability	good	good	good	good	poor	No polymers formed (except with H ₂ ions)						Excellent – decomposes to gas only above 300 °C*
Oxidation resistance	good	good	good	good	poor to fair	Excellent						Excellent
Chemical resistance	fair	fair	fair	fair	poor to good	Excellent						Excellent
Radiation resistance	fair	fair	fair	fair	fair	Good – but reacts with electro-positive metals (for example, sodium)						

* WARNING – Perfluoropolyether is a fluorinated compound which will give off toxic vapours if exposed to temperatures above 280 °C. The fluid should not be exposed to naked flames and smoking should be prohibited in the working area.
 • Suitable for this application.
 † Vapour pressure at 25 °C.

Krytox® is a registered trademark of Dupont Dow Elastomers

Perfluoropolyether Oils

Edwards now offers an extended range of Fomblin® and Krytox®, perfluoropolyether oils for use in rotary vacuum pumps. Fomblin® YVAC 06/6 and Krytox® 1506 are recommended for Edwards oil sealed rotary pumps and are practically a direct replacement for mineral oil in terms of viscosity and vapour pressure. Krytox® 1525 is suitable for use in rotary pumps requiring a viscosity equivalent to Fomblin® Y25 fluid. Fomblin® Y16/6 and Krytox® 1514 are recommended for use in perfluoropolyether adapted mechanical booster pumps.

Edwards, in conjunction with Ausimont UK, has developed Drynert fluid which contains anti-rust and anti-wear additives soluble in Fomblin®. These additives cover metallic surfaces with a protective, corrosion resistant film.

Ordering Information

Product Description	Order No.		
	Europe	N. America	
Fomblin® YVAC 06/6	100 ml	N/A	H026004001
	240 ml	N/A	H026004002
	0.5 kg	N/A	H026004003
	1 kg (532 ml)	H11301019	H11301019
	2 kg	N/A	H026004005
	5 kg	H11301020	H11301020
Krytox® 1506 fluid	8 kg	N/A	H026004006
	0.5 kg	N/A	H11307017
	1 kg (532 ml)	H11307018	H11307018
Krytox® 1525 fluid	5 kg (2660 ml)	H11307020	H11307020
	0.5 kg	N/A	H11309017
	1 kg (526 ml)	H11309018	H11309018
Fomblin® Y16/6 fluid	5 kg	H11309020	H11309020
	0.5 kg	N/A	H026001003
	1 kg (529 ml)	H11306019	H11306019
Krytox® 1514 fluid	2 kg	N/A	H026001005
	5 kg	H11306020	H11306020
	8 kg	N/A	H026001006
	0.5 kg	N/A	H11308017
Fomblin® 25/6 fluid	1 kg (529 ml)	H11308018	H11308018
	5 kg (2646 ml)	H11308020	H11308020
	100 ml	N/A	H026008001
Drynert 25/6 fluid	0.5 kg	N/A	H026008003
	1 kg (529 ml)	H11312019	H11312019
	2 kg	N/A	H026008005
	5 kg (2646 ml)	H11312020	H11312020
	8 kg	N/A	H026008006
	50 kg	N/A	H026008007
Krytox® 1514 fluid	1 kg (529 ml)	H11312021	H11312021
	5 kg (2646 ml)	H11312025	H11312025

Single Stage and Rough Pump Oil Selection Chart

		LOWVAC 60	V-Lube CD	V-Lube F	V-Lube G	V-lube H
Vapour pressure mbar	20 °C	7.5×10^{-5}	<1.3	<1.3	<1.3	<1.3
	100 °C	3.9×10^{-2}	<1.3	<1.3	<1.3	<1.3
Molecular weight		485	350-500	350-500	350-500	350-500
Specific gravity at 20 °C		0.80	0.87-0.89	0.86-0.88	0.88-0.89	0.88-0.91
Viscosity cSt at 40 °C	0	59.1	68	95.5-100	183-191	208-220
Pour point °C		-45	-31	-36	-30	-25
Flash point °C		209	210	223	216	220
Auto ignition point °C		360	343	TBC	343	343
Sulphur content% mass/mass		0	0	0.281	0	0
Energetic particle impact		Conducting polymers formed				
Thermal stability		good	good	good	good	good
Oxidation resistance		good	good	good	good	good
Chemical resistance		fair	fair	fair	fair	fair
Radiation resistance		fair	fair	fair	fair	fair

Vapour Pump Fluids

Edwards supplies a range of fluids of different vapour pressures and physical properties. From this range, you can choose the optimum fluid for your applications.

In general, the more volatile fluids are used with vapour booster pumps and for vapour diffusion pumps used on industrial processes (for example, decorative coating and vacuum furnaces) where high gas loads are encountered and high critical backing pressure is advantageous. The less volatile fluids are used for processes or experiments requiring more exacting high vacuum conditions. The least volatile fluids are used for clean or ultra high vacuum applications (mass spectrometry, electron probe apparatus, surface studies, and so forth). Fluid selection depends also on the particular physical and chemical characteristics of the fluids (apart from vapour pressure).

Edwards has a long history of co-operation with various fluid manufacturers in the development of new pumping fluids and is well placed to advise in cases of uncertainty.

AP201 Vapour Booster Pump Fluid

Apiezon® AP201 is a hydrocarbon fluid prepared by molecular distillation and protected against oxidation by a thermally stable additive of matched vapour pressure. It has an auto ignition temperature of 305 °C.

It exhibits a fair degree of resistance to chemical degradation (so that high throughputs of air and water vapour can be pumped without damage to the fluid) and it can withstand limited accidental admission of atmospheric air at operating temperature. The fluid has low viscosity which permits easy filling and draining. It does not attack synthetic rubbers used for seals and gaskets in vacuum systems. It is non-irritant, non-toxic and environmentally non-polluting.

Ordering Information

Product Description	Order No.
AP201 vapour booster pump fluid	
4 litres	H02601054
20 litres	H02601052
200 litres	H02601050

Edwards L9 Diffusion Pump Fluid

Edwards L9 fluid has been developed for use in Diffstak and diffusion pumps. It is a naphthalene based synthetic material which is ideal for use in applications where silicones (which form insulating films) cannot be tolerated.

L9 fluid is rugged, has a very good vacuum performance and gives an ultimate pressure of typically 5×10^{-9} mbar (at 20 °C).

In addition, the fluid is chemically stable and is resistant to acids, alkalis, halogens and oxides of nitrogen. It does not react with common engineering metals or elastomers. It is immiscible to the common solvents alcohol, acetone and trichlorotrifluoroethane. The toxicity level of L9 is very low.

Safety note: When changing to this fluid the pump should be cleaned using a proprietary fluid. The pump should then be rinsed in acetone and dried prior to re-charging.

Ordering Information

Product Description	Order No.
Edwards L9 fluid 1 litre	H11501015

Silicone DC702, DC704EU and DC705 Diffusion Pump Fluids

These synthetic fluids are organo-silicon oxide polymers and have exceptional chemical stability both at high temperature and when in contact with most gases and vapours. They provide a range of general purpose fluids for ultimate vacuum from about 10^{-5} to 10^{-9} mbar, and are particularly useful in industrial processing applications due to their exceptional ruggedness. High throughputs of air, water vapour and corrosive gases can be pumped without fluid degradation. The fluids can withstand repeated admission of atmospheric air while at operating temperature and are widely used in valveless quick-cycle pumping processes. They have low toxicity and good resistance to gamma radiation.

Fluid breakdown products (due to bombardment and so on) tend to be electrically insulating and so we do not recommend these fluids for physical electronic applications such as mass spectrometers and surface analysis systems. The fluids are indifferent lubricants. Their decomposition is catalysed by traces of alkali metals (for example, caesium) and their use should be avoided where possible.

Ordering Information

Product Description	Order No.	
	Europe	N. America
Silicone 702		
500 ml	H02400007	H02400007
1 US gal	N/A	H02400008
5 kg (4673 ml)	H02400038	N/A
Silicone 704EU		
500 ml	H11201040	H02400043
1 US gal	N/A	H02400011
5 kg (4673 ml)	H11201041	N/A
Silicone 705		
500 ml	H02400027	H02400027

Santovac® 5 Diffusion Pump Fluid

This synthetic fluid is a polyphenyl ether developed from fluids originally produced as lubricants for space vehicles. It has exceptionally low vapour pressure, exceptional thermal stability and a tendency to wet surfaces less readily and "creep" to a lesser extent than is common with most fluids. The fluid is employed for the cleanest high vacuum and ultra high vacuum applications down to less than 10^{-9} mbar (for example, electron microscopes, mass spectrometers and surface physics studies) where its excellent high vacuum performance and low tendency to migrate into the pump system particularly recommend it. The fluid is chemically stable, non-corrosive, safe and non-toxic at normal operating temperatures. Fluid breakdown products (due to bombardment and so forth) tend to be electrically conducting. Lubricating qualities are good and the fluid finds application to lubricate mechanisms in vacuum systems.

Ordering Information

Product Description	Order No.	
	Europe	N. America
Santovac® 5 fluid		
100 ml	H11401001	H02300045
500 ml	H11401002	H02300046

Vapour Pump Fluid Selection Chart

	Apiezon®		Silicone		Santovac® 5	L9
	AP201	702	704EU	705		
Mass Spectrometers					•	•
Electron Microscopes					•	•
Thin Film Sputtering					•	
Surface Studies					•	
UHV Systems				•	•	
Leak Detection					•	
TV Tubes		•	•			
Power Valves					•	•
Spaces Studies					•	
Furnaces	•					
Radioactive					•	
Vapour Booster	•					
Metallisation		•	•			
Typical ultimate vacuum achievable at 20 °C (mbar)	6.5×10^{-5}	6.5×10^{-6}	6.5×10^{-8}	1.3×10^{-9}	1.3×10^{-9}	5×10^{-9}
Vapour pressure (mbar) at 20 °C	5×10^{-6}	6.5×10^{-7}	1.3×10^{-8}	2.6×10^{-10}	2.6×10^{-10}	7.8×10^{-10}
at 100 °C	2.4×10^{-2}	1.3×10^{-3}	2.6×10^{-4}	1.3×10^{-5}	6.5×10^{-6}	2.6×10^{-5}
at 150 °C	6.5×10^{-1}	$< 10^{-1}$	1.3×10^{-2}	$< 10^{-3}$	4×10^{-4}	2.3×10^{-3}
Boiling temperature at 1.3 mbar (°C) (approximate)	160	185	223	254	295	251
Molecular weight (average)	310	530	484	546	446	407
Viscosity cSt at						
20 °C	34	55	47	240	2400	71.3
100 °C	5.0	4.9	4.3	7.9	12	5.6
150 °C	2.7	2.4	2.2	3.3	4.5	1.2
Pour point (°C) (approximate)	-30	< -20	< -20	-10	+5	-5
Flash point (°C)	196	193	221	243	288	241
Fire point (°C) (approximate)	204	275	275	275	350	281
Auto ignition point (°C) (approximate)	305	500	500	500	590	370
Specific heat (cal/g/°C)	0.46	0.42	0.41	0.42	–	0.46
Latent heat (cal/g)	69	40.9	52.7	51.6	49.2	42
Specific gravity at 25 °C	0.862	1.07	1.07	1.09	1.195	0.901
Coefficient of expansion per deg C	0.0007 (10 – 30 °C)	0.0008 (25 – 50 °C)	0.0008 (25 – 50 °C)	0.0006 (25 – 50 °C)	0.0008 (25 – 50 °C)	0.00042 (25 – 50 °C)
Refractive index at room temperature	1.476	1.516	1.557	1.579	1.6306 (25 °C)	1.5154 (25 °C)
Energetic Particle Bombardment	conducting polymers formed	insulating polymers formed			conducting polymers formed	
Thermal Stability	poor	very good			excellent	good
Oxidation Resistance	Poor to fair	excellent			very good	good
Chemical Resistance	poor	very good but decomposed by alkali metal			good	very good
Radiation Resistance	fair	good			very good	fair

• Recommended for this application

Greases and Waxes



Silicone Grease

A high vacuum grade grease, which is for use at system pressures lower than 10^{-6} mbar.

Ordering Information

Product Description	Order No.
Silicone, high vacuum grease, tube 50 g	H02400036
Silicone, high vacuum grease, pack 5 kg	H11251015

Fomblin® Grease

This grease is an excellent lubricant for sliding elastomer seals, and exhibits the chemical inertness typical of the Fomblin® range.

It has a very low vapour pressure and is suitable for use in the presence of gaseous and liquid oxygen under severe conditions.

The general purpose AR555 grease offered by Edwards has the basic properties of Fomblin®, but the vapour pressure is not specifically controlled. The vapour pressure is $<10^{-7}$ mbar at 20 °C.

Ordering Information

Product Description	Order No.
Fomblin® vacuum grease AR555 grade, syringe 100 g	H11350013

Krytox® Grease

DuPont Krytox® fluorinated greases are a family of multipurpose lubricants intended for use in speciality applications at elevated temperatures or in aggressive environments.

Ordering Information

Product Description	Order No. N. America
Krytox® 240AD, tube (57 g, 2 oz)	U30002525
Krytox® 240AD, tube (226 g, 8 oz)	U30002206
Krytox® 240AB, tube (57 g, 2 oz)	U30002536
Krytox® 240AB, tube (226 g, 8 oz)	U30002535
Krytox® 240AC, tube (57 g, 2 oz)	U30002538
Krytox® 240AC, tube (226 g, 8 oz)	U30002537
Krytox® LVP, tube (57 g, 2 oz)	U30002075
Krytox® LVP, tube (226 g, 8 oz)	U30002539

Waxes and Sealing Compounds (Mineral Based)

Apiezon® wax W is a low vapour pressure wax for sealing joints in high vacuum systems. This wax softens at 80-90 °C and has a vapour pressure at 80 °C of 10^{-3} mbar and at 20 °C of 10^{-8} mbar.

Apiezon® wax W40 is similar to type W, but has a lower softening point which makes it very suitable for flow sealing in or around vacuum joints. It is not recommended for use at temperatures above 30 °C. It has a vapour pressure at 20 °C of 10^{-7} mbar.

Apiezon® sealing compound Q remains firm for temperatures up to 30 °C, but is sufficiently pliable to permit easy moulding into position. It is an excellent material for shielding or blanking off sections of apparatus. The compound is easily applied and can be readily removed. It has a vapour pressure at 20 °C of 10^{-4} mbar.

Ordering Information

Product Description		Order No.
Apiezon® W wax	20 x 25 g	H02301014
Apiezon® W wax	pack 1 kg	H11176007
Apiezon® W40 wax	pack 250 g	H02301015
Apiezon® Q sealing compound	tin 1 kg	H02300012

Apiezon® Greases

A range of Apiezon® greases is offered for use on high vacuum systems and for many general applications in the laboratory. These high purity greases are non-toxic, easy to apply, easy to clean off and have long shelf lives.

Applications include:

- Lubrication of glass and metal taps in vacuum systems
- Sealing polymer joints in vacuum systems
- Leak detection
- Protecting metal contacts in vacuum-encapsulated relays
- Sealing polished and ground glass/metal surfaces
- Optical surfaces in vacuum systems and laser systems – does not cause clouding (L and M greases only)
- Non vacuum uses include lubrication of glass and metal taps in laboratory, medical and industrial applications
- Good “gettering” qualities (absorbs grease and chemical impurities) – ideal for electronics industry

Choice of grease depends largely on operating temperature (see below).

Anti Seize Greases

	AP100	AP101
Melting point	47 °C	>200 °C
Radiation resistant	No	No
Vapour pressure at 20 °C (mbar)	$<10^{-10}$	$<10^{-5}$
Comments	High vacuum; good lubrication, resists alkali, acid and corrosive gas; easily removed by most solvents. Particularly good for polished/ground glass joints.	Medium vacuum, heavy duty grease; wide temperature base, ideal for laboratory work.

Lubricant (unmodified)

	L	M
Melting point	47 °C	44 °C
Radiation resistant	Yes	Yes
Vapour pressure at 20 °C (mbar)	<10 ⁻¹⁰	<10 ⁻¹⁰
Comments	High vacuum, low temperature; nuclear, space industries; liquid gas chromatography	Similar to L grease, but stiffer; good gettinger properties

Lubricant (polymers added)

	N	T	H
Melting point	43 °C	125 °C	N/A*
Radiation resistant	No	No	No
Vapour pressure at 20 °C (mbar)	<10 ⁻⁹	<10 ⁻⁸	<10 ⁻⁷
Comments	Rubbery, tenacious; cushions glass mating surfaces, ideal for burette taps. Cryogenic.	As N grease, but higher temperature; glass and general lubrication	Very high temperature; becomes stiffer as temperature increases

* Grease H can withstand temperatures up to 250 °C without melting

Ordering Information

Product Description	Order No.	
	Europe	N. America
Apiezon [®] L grease (50 g)	H02301041	H02301041
Apiezon [®] L grease (25 g)	N/A	H02301042
Apiezon [®] M grease (100 g)	H02301040	H02301040
Apiezon [®] M grease (25 g)	N/A	H11151002
Apiezon [®] N grease (25 g)	H02301011	H02301011
Apiezon [®] T grease (25 g)	H02301018	H02301018
Apiezon [®] AP100 grease (50 g)	H02300043	H02300043
Apiezon [®] AP101 grease (50 g)	H02301044	H02301044
Apiezon [®] AP101 grease (4 kg)	H02301045	H02301045
Apiezon [®] H grease (25 g)	H11150001	H11150001



iXL Dry Pumps	248
EPX on-tool High Vacuum Pumps	250
GX Dry Pumps	266
Exhaust Management for Semiconductor Processes	272

iXL120 Dry Pump System



iXL120 is a compact, low energy, $110 \text{ m}^3 \text{ h}^{-1}$ dry pump for wafer handling and other clean duty applications. It provides fast pump down of load lock chambers with extremely low energy consumption.

iXL120 is one of the smallest and lightest pumps available for load lock and clean applications. Its low vibration and low noise levels make it ideal for mounting on-tool or within a fab's waffle floor, helping to save valuable fab floor space. A Green Mode allows reduced utilities usage during idle periods, lowering utility costs and helping to save the environment!

Features & Benefits

- Class leading chamber pump down time reduces Total Average Cycle Time (TACT)
- Only 0.55kW power consumption helps minimise customer cost of ownership
- Green Mode can reduce power consumption by up to 92% during idle periods
- Up to 35°C water supply helps reduce facility cooling water requirements
- Extremely small and light, helping to save valuable fab space

Dimensions

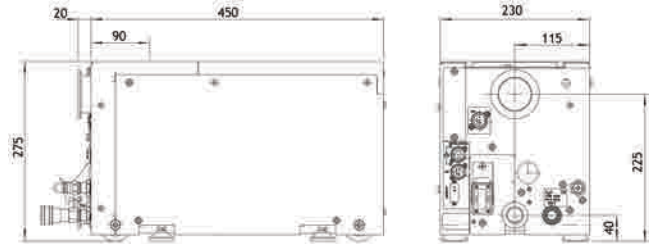

Performance Curves

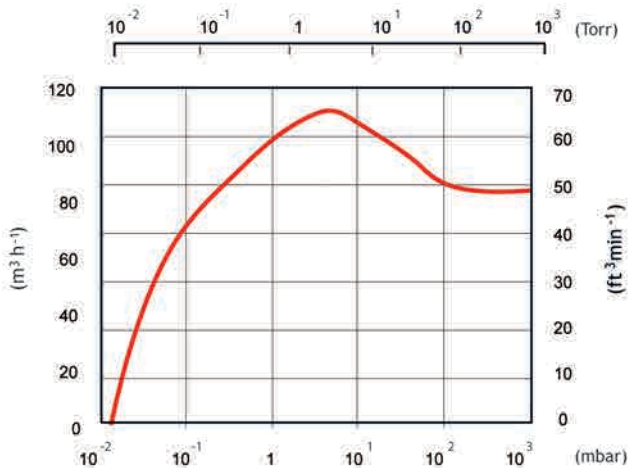

Ordering Information

Product Description	Order No.
iXL120 E 200-460V 3/8 QC Water Fittings	A54113010
iXL120 E 200-460V 1/4 QC Water Fittings	A54113020
iXL120 E 200-460V HIT 3/8 QC Water Fittings	A54113610
iXL120 E 200-460V MCM 3/8 QC Water Fittings	A54113710
iXL120 E 200-460V 3/8 QC Water Fittings Flow Cont Valve	A54113011
iXL120 E 200-460V SPI 1/4 QC Water Fittings Flow Cont Valve	A54113221
iXL120 E 200-460V HIT 3/8 QC Water Fittings Flow Cont Valve	A54113611
iXL120 E 200-460V MCM 3/8 QC Water Fittings Flow Cont Valve	A54113711
iXL120N E 200-460V 3/8 QC Water Fittings	A54114010
iXL120N E 200-460V 1/4 QC Water Fittings	A54114020
iXL120N E 200-460V SPI TIM 3/8 QC Water Fittings	A54114210
iXL120N E 200-460V TEL 3/8 QC Water Fittings	A54114410
iXL120N E 200-460V 3/8 QC Water Fittings Flow Cont Valve	A54114011
iXL120N E 200-460V TEL 3/8 QC Water Fittings Flow Cont Valve	A54114411

Technical Data

Product	iXL120
Peak speed	110 m ³ h ⁻¹ 65 cfm
Ultimate pressure (typical)	1833 lmin ⁻¹ 0.013 mbar 0.009 Torr 1.3 Pa
Power at ultimate	0.55 kW
Power in Green Mode	0.045 kW
Inlet connection	
Vertical	ISO63
Horizontal	NW50
Outlet connection	NW25
Cooling water connection	Optional
Water flow	1 lmin ⁻¹
Weight	59 kg

EPX180L Dry pump



The new compact EPX180 high vacuum drypump offers enhanced performance with reduced cost of ownership. Using a unique patent protected mechanism the EPX180 is capable of pumping from atmosphere to ultimate pressures of $<7 \times 10^{-5}$ Torr.

Based on the successful award winning IPX range, the modular EPX180 offers outstanding performance in a package that is 20% lighter, 30% smaller and requires 40% less power than the IPX.

Features & Benefits

- Compact footprint - as one of the smallest on-tool pumps available, the EPX offers outstanding savings in footprint. EPX can be mounted directly onto the tool saving foreline and installations costs or remotely if preferred.
- Low cost of ownership - EPX requires only 1.4 kW of power and incorporating idle mode to maximize power efficiency.
- Unique patent protected pumping mechanism - the EPX can pump down from atmosphere to turbomolecular base pressure and can operate continuously at all inlet pressures.
- Ultra clean mechanism - conventional high vacuum bearings under grease use grease lubrication which can be a source of contamination in process tools. EPX pumps have no high vacuum bearings under grease and present no other source of potential contamination.
- Extremely reliable - based on field proven IPX technology, the EPX has a $MTBF_p = 13$ years (SEMI E10) with service periods of around every 5 years to maximize the life of the pump.

Applications

- The EPX series covers a broad range of applications from wafer handling through to medium duty processes. The EPX 'L' Series has been designed for use clean duty applications pumping inert gas mixtures, such as loadlock, whereby control is provided by the process tool interface.

Dimensions

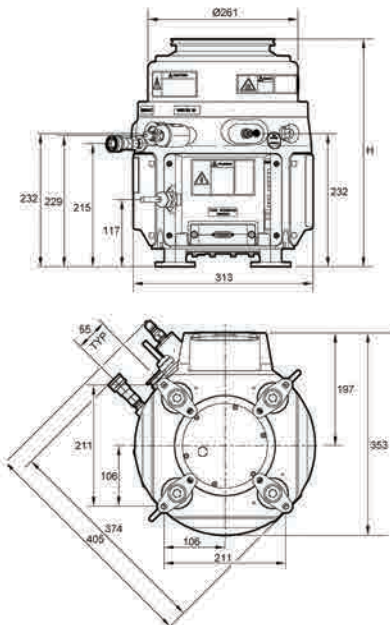

H = 388 (EPX180) H = 397 (EPX500)

Performance Curves

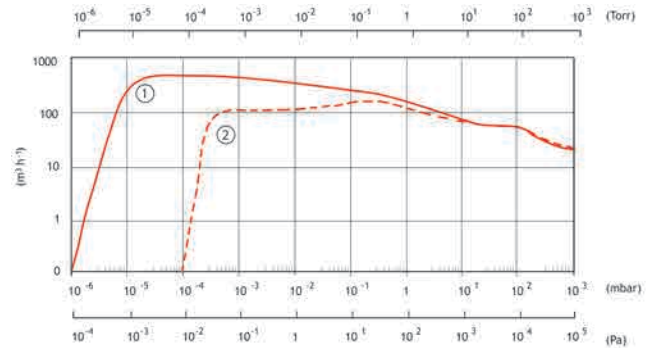

1. EPX500 2. EPX180

Technical Data

Peak speed	170 m ³ h ⁻¹ 105 ft ³ min ⁻¹ 2835 lmin ⁻¹
Ultimate vacuum	<1 x 10 ⁻⁴ mbar <7.5 x 10 ⁻⁵ Torr <1 x 10 ⁻² Pa
Warm-up time (to nominal performance)	30 min
Inlet flange	ISO63
Outlet flange	NW25
Noise	<59 dB(A)
Water connectors	3/8 in Quick
Minimum cooling water flow rate	2 lmin ⁻¹
Cooling water temperature	15 – 35 °C
Electrical Supply	200/208 V, 50/60 Hz 3 phase
Power at ultimate	1.4 kW
Rated motor power	3.0 kW
TIM	C3
Weight	43.5 kg

Ordering Information

Product Description	Order No.
EPX180L Dry pump 400V, 3/8 water connector	A41941014
EPX180L Dry pump 208V C3 TIM 9/16 water connector	A41941132
EPX180L Dry pump 208V SPI TIM 3/8 water connector	A41941212
EPX180L Dry pump 208V SPI TIM 1/4 water connector	A41941222
EPX180L Dry pump 208V E73 TIM 3/8 water connector	A41941312
EPX180L Dry Pump 400V E73 TIM 3/8 water connectors	A41941314
EPX180L Dry pump 208V TEL TIM 3/8 water connector	A41941412
EPX180L Dry Pump 400V LAM TIM 3/8 water connectors	A41941514
EPX180L Dry Pump 208V MCM TIM 3/8 water connector	A41941712
EPX180L Dry pump 200V	A41941002
EPX180L Dry pump 200V, 3/8 water connector	A41941012
EPX180L Dry pump 208V C3 TIM 3/8 water connector	A41941112
EPX180L Dry pump 400V 1/4 water connector	A41941024
EPX180L Dry pump 208V C3 TIM 3/8 water connector	A41941142
EPX180L Dry pump 208V C3 TIM 3/8 water connector	A41941152
EPX180L Dry pump 400V SPI TIM 3/8 water connector	A41941214

EPX180LE Dry Pump



The new compact EPX180 high vacuum drypump offers enhanced performance with reduced cost of ownership. Using a unique patent protected mechanism the EPX180 is capable of pumping from atmosphere to ultimate pressures of $<7 \times 10^{-5}$ Torr.

The EPX LE series of pumps has an End User Controller (EUC). The End User Controller enables local control for stand-alone use as well as the ability to connect to a fab-wide network for remote control and monitoring.

Features & Benefits

- Compact footprint - as one of the smallest on-tool pumps available, the EPX offers outstanding savings in footprint. EPX can be mounted directly onto the tool saving foreline and installations costs or remotely if preferred.
- Low cost of ownership - EPX requires only 1.4 kW of power and incorporating idle mode to maximize power efficiency.
- Unique patent protected pumping mechanism - the EPX can pump down from atmosphere to turbomolecular base pressure and can operate continuously at all inlet pressures.
- Ultra clean mechanism - conventional high vacuum bearings under grease use grease lubrication which can be a source of contamination in process tools. EPX pumps have no high vacuum bearings under grease and present no other source of potential contamination.
- Extremely reliable - based on field proven IPX technology, the EPX has a $MTBF_p = 13$ years (SEMI E10) with service periods of around every 5 years to maximize the life of the pump.

Applications

- The EPX series covers a broad range of applications from wafer handling through to medium duty processes. The EPX 'LE' Series has been designed for use clean duty applications pumping inert gas mixtures, such as loadlock, whereby control is provided by the process tool interface.

Dimensions

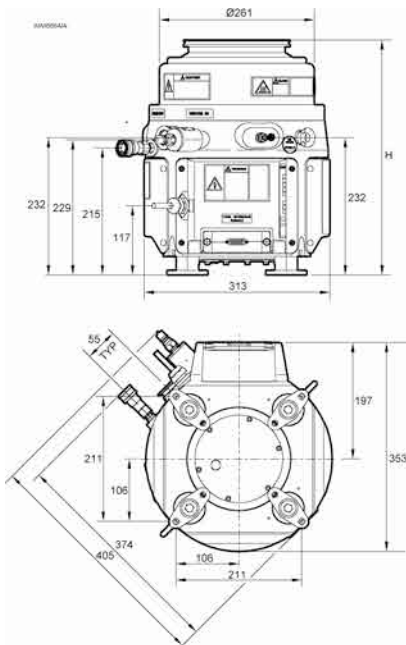

H = 388 (EPX180) H = 397 (EPX500)

Performance Curves

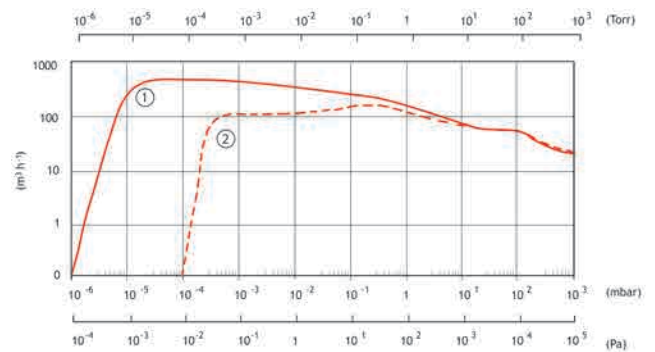

1. EPX500 2. EPX180

Technical Data

Peak speed	170 m ³ h ⁻¹ 105 ft ³ min ⁻¹ 2835 lmin ⁻¹
Ultimate vacuum	<1 x 10 ⁻⁴ mbar <7.5 x 10 ⁻⁵ Torr <1 x 10 ⁻² Pa
Warm-up time (to nominal performance)	30 min
Inlet flange	ISO63
Outlet flange	NW25
Noise	<59 dB(A)
Water connectors	3/8 in Quick
Minimum cooling water flow rate	2 lmin ⁻¹
Cooling water temperature	15 – 35 °C
Electrical Supply	200/208 V, 50/60 Hz 3 phase
Power at ultimate	1.4 kW
Rated motor power	3.0 kW
TIM	None
Weight	43.5 kg

Ordering Information

Product Description	Order No.
EPX180LE Dry Pump 208V No TIM 3/8 water connector	A41943012
EPX180LE Dry Pump 400V No TIM 3/8 water connectors	A41943014
EPX180LE Dry Pump 208V No TIM 1/4 water connector	A41943022
EPX180LE Dry Pump 400V No TIM 1/4 water connectors	A41943024
EPX180LE Dry Pump 208V C3 TIM 3/8 water connector	A41943112
EPX180LE Dry Pump 208V SPI TIM 3/8 water connector	A41943212
EPX180LE Dry Pump 208V SPI TIM 1/4 water connector	A41943222
EPX180LE Dry Pump 400V SPI TIM 1/4 water connectors	A41943224
EPX180LE Dry Pump 208V TEL TIM 3/8 water connector	A41943412
EPX180LE Dry Pump 208V Hitachi TIM 3/8 water connector	A41943612
EPX180LE Dry Pump 208V MCM TIM 3/8 water connector	A41943712
EPX180LE Dry Pump 400V MCM TIM 3/8 water connectors	A41943714
EPX180LE Dry Pump 208V MCM TIM 1/4 water connector	A41943722

EPX180N Dry pump



The new compact EPX180 high vacuum drypump offers enhanced performance with reduced cost of ownership. Using a unique patent protected mechanism the EPX180 is capable of pumping from atmosphere to ultimate pressures of $<7 \times 10^{-5}$ Torr.

Based on the successful award winning IPX range, the modular EPX180 offers outstanding performance in a package that is 20% lighter, 30% smaller and requires 40% less power than the IPX.

Features & Benefits

- Compact footprint - as one of the smallest on-tool pumps available, the EPX offers outstanding savings in footprint. EPX can be mounted directly onto the tool saving foreline and installations costs or remotely if preferred.
- Low cost of ownership - EPX requires only 1.4 kW of power and incorporating idle mode to maximize power efficiency.
- Unique patent protected pumping mechanism - the EPX can pump down from atmosphere to turbomolecular base pressure and can operate continuously at all inlet pressures.
- Ultra clean mechanism - conventional high vacuum bearings under grease use grease lubrication which can be a source of contamination in process tools. EPX pumps have no high vacuum bearings under grease and present no other source of potential contamination.
- Extremely reliable - based on field proven IPX technology, the EPX has a $MTBF_p = 13$ years (SEMI E10) with service periods of around every 5 years to maximize the life of the pump.

Applications

- Load Lock
- Transfer Chamber
- PVD sputtering
- Ashing/PR Strip
- Dielectric Etch

Dimensions

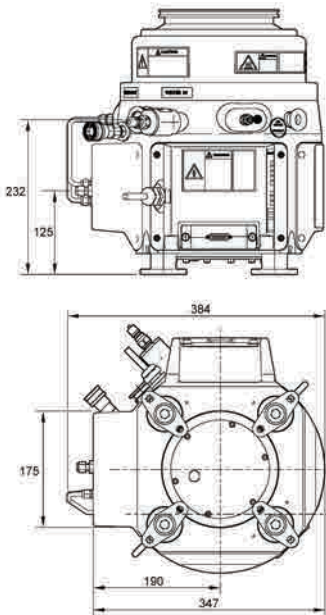

H = 388 (EPX180) H = 397 (EPX500)

Performance Curves

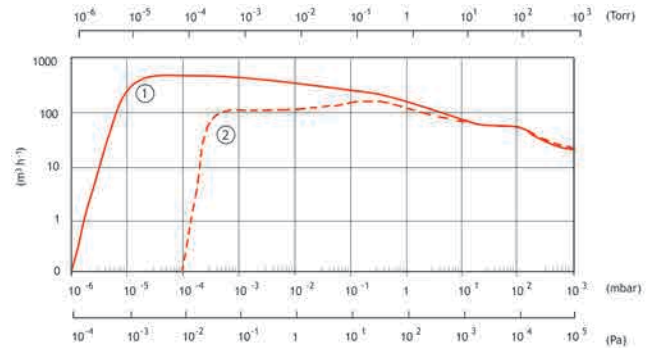

1. EPX500 2. EPX180

Technical Data

Peak speed	170 m ³ h ⁻¹ 105 ft ³ min ⁻¹ 2835 lmin ⁻¹
Ultimate vacuum	<1 x 10 ⁻⁴ mbar <7.5 x 10 ⁻⁵ Torr <1 x 10 ⁻² Pa
Warm-up time (to nominal performance)	30 min
Inlet flange	ISO63
Outlet flange	NW25
Noise	<59 dB(A)
Water connectors	3/8 in Quick
Minimum cooling water flow rate	2 lmin ⁻¹
Cooling water temperature	15 – 35 °C
Nitrogen supply interface	1/4 in (6.5 mm) tube
Nitrogen supply pressure	3 x 10 ⁵ – 7 x 10 ⁵ pa
Minimum nitrogen purity	99.95%
Electrical Supply	200/208 V, 50/60 Hz 3 phase
Power at ultimate	1.4 kW
Rated motor power	3.0 kW
TIM	C3
Weight	43.5 kg

Ordering Information

Product Description	Order No.
EPX180N Dry pump 208V C3 TIM 3/8 water connector	A41942112
EPX180N Dry pump 208V SPI TIM 3/8 water connector	A41942212
EPX180N Dry pump 208V SPI TIM 1/4 water connector	A41942222
EPX180N Dry pump 208V E73 TIM 3/8 water connector	A41942312
EPX180N Dry pump 208V TEL TIM 3/8 water connector	A41942412
EPX180N Dry pump 400V TEL TIM 3/8 water connectors	A41942414
EPX180N Dry pump 208V MCM TIM 3/8 water connector	A41942712
EPX180N Dry pump 400V MCM TIM 3/8 water connectors	A41942714
EPX180N Dry pump 400V, 3/8 water connector	A41942014

EPX180NE Dry pump



The new compact EPX180 high vacuum drypump offers enhanced performance with reduced cost of ownership. Using a unique patent protected mechanism the EPX180 is capable of pumping from atmosphere to ultimate pressures of $<7 \times 10^{-5}$ Torr.

The EPX NE series of pumps has an End User Controller (EUC). The End User Controller enables local control for stand-alone use as well as the ability to connect to a fab-wide network for remote control and monitoring.

Features & Benefits

- Compact footprint - as one of the smallest on-tool pumps available, the EPX offers outstanding savings in footprint. EPX can be mounted directly onto the tool saving foreline and installations costs or remotely if preferred.
- Low cost of ownership - EPX requires only 1.4 kW of power and incorporating idle mode to maximize power efficiency.
- Unique patent protected pumping mechanism - the EPX can pump down from atmosphere to turbomolecular base pressure and can operate continuously at all inlet pressures.
- Ultra clean mechanism - conventional high vacuum bearings under grease use grease lubrication which can be a source of contamination in process tools. EPX pumps have no high vacuum bearings under grease and present no other source of potential contamination.
- Extremely reliable - based on field proven IPX technology, the EPX has a $MTBF_p = 13$ years (SEMI E10) with service periods of around every 5 years to maximize the life of the pump.

Applications

- Load Lock
- Transfer Chamber
- PVD sputtering
- Ashing/PR Strip
- Dielectric Etch

Dimensions

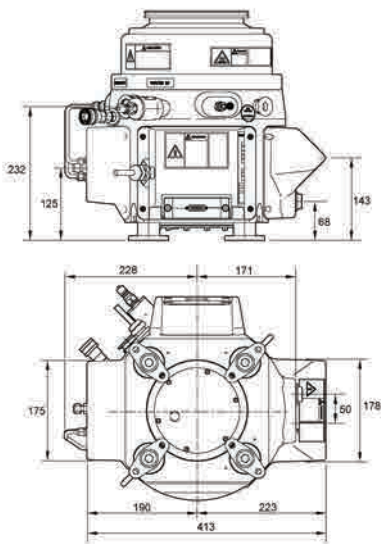

H = 388 (EPX180) H = 397 (EPX500)

Performance Curves

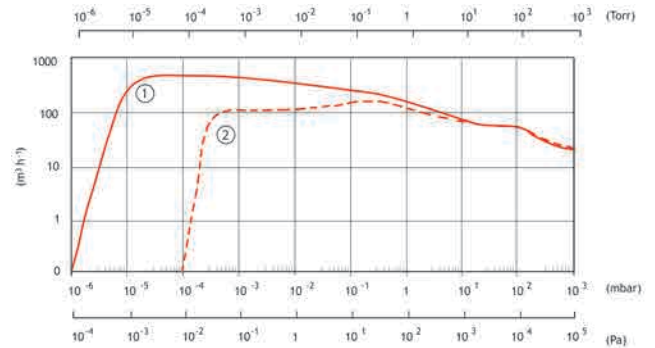

1. EPX500 2. EPX180

Technical Data

Peak speed	170 m ³ h ⁻¹ 105 ft ³ min ⁻¹ 2835 lmin ⁻¹
Ultimate vacuum	<1 x 10 ⁻⁴ mbar <7.5 x 10 ⁻⁵ Torr <1 x 10 ⁻² Pa
Warm-up time (to nominal performance)	30 min
Inlet flange	ISO63
Outlet flange	NW25
Noise	<59 dB(A)
Minimum cooling water flow rate	2 lmin ⁻¹
Cooling water temperature	15 – 35 °C
Nitrogen supply interface	1/4 in (6.5 mm) tube
Nitrogen supply pressure	3 x 10 ⁵ – 7 x 10 ⁵ pa
Minimum nitrogen purity	99.95%
Electrical Supply	400 V, 50/60 Hz 3 phase
Power at ultimate	1.4 kW
Rated motor power	3.0 kW
TIM	None
Weight	43.5 kg

Ordering Information

Product Description	Order No.
EPX180NE Dry pump 208V SPI TIM 3/8 water connector	A41944212
EPX180NE Dry pump 400V SPI TIM 1/4 water connectors	A41944224
EPX180NE Dry pump 208V TEL TIM 3/8 water connector	A41944412
EPX180NE Dry pump 400V TEL TIM 3/8 water connectors	A41944414
EPX180NE Dry pump 400V TEL TIM 1/4 water connectors	A41944424
EPX180NE Dry pump 208V LAM TIM 3/8 water connector	A41944512
EPX180NE Dry pump 400V LAM TIM 3/8 water connectors	A41944514
EPX180NE Dry pump 208V MCM TIM 3/8 water connector	A41944712
EPX180NE Dry pump 400V MCM TIM 3/8 water connectors	A41944714
EPX180NE Dry pump 400V MCM TIM 1/4 water connectors	A41944724
EPX180NE Dry pump 208V No TIM 3/8 water connector	A41944012
EPX180NE Dry pump 400V No TIM 3/8 water connector	A41944014

EPX500L Dry Pump



The new compact EPX500 high vacuum drypump offers enhanced performance with reduced cost of ownership. Using a unique patent protected mechanism the EPX500 is capable of pumping from atmosphere to ultimate pressures of $<7 \times 10^{-5}$ Torr.

Based on the successful award winning IPX range, the modular EPX500 offers outstanding performance in a package that is 20% lighter, 30% smaller and requires 40% less power than the IPX.

Features & Benefits

- Compact footprint - as one of the smallest on-tool pumps available, the EPX offers outstanding savings in footprint. EPX can be mounted directly onto the tool saving foreline and installations costs or remotely if preferred.
- Low cost of ownership - EPX requires only 1.4 kW of power and incorporating idle mode to maximize power efficiency.
- Unique patent protected pumping mechanism - the EPX can pump down from atmosphere to turbomolecular base pressure and can operate continuously at all inlet pressures.
- Ultra clean mechanism - conventional high vacuum bearings under grease use grease lubrication which can be a source of contamination in process tools. EPX pumps have no high vacuum bearings under grease and present no other source of potential contamination.
- Extremely reliable - based on field proven IPX technology, the EPX has a $MTBF_p = 13$ years (SEMI E10) with service periods of around every 5 years to maximize the life of the pump.

Applications

- The EPX series covers a broad range of applications from wafer handling through to medium duty processes. The EPX 'L' Series has been designed for use clean duty applications pumping inert gas mixtures, such as loadlock, whereby control is provided by the process tool interface.

Dimensions

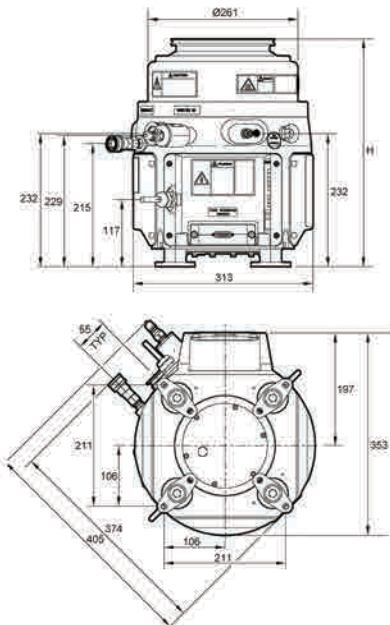

H = 388 (EPX180) H = 397 (EPX500)

Performance Curves

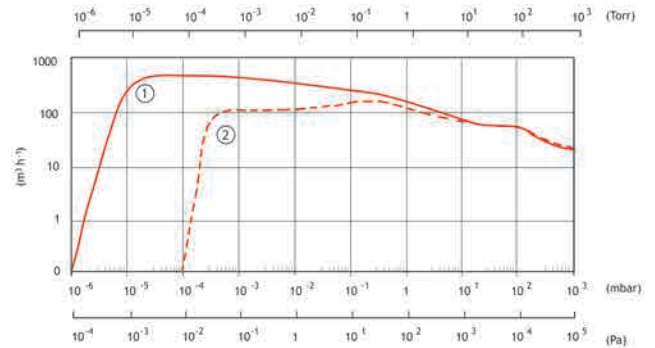

1. EPX500 2. EPX180

Technical Data

Peak speed	500 m ³ h ⁻¹ 295 ft ³ min ⁻¹ 8338 lmin ⁻¹
Ultimate vacuum	<1 x 10 ⁻⁶ mbar <7.5 x 10 ⁻⁷ Torr <1 x 10 ⁻⁴ Pa
Warm-up time (to nominal performance)	30 min
Inlet flange	ISO160
Outlet flange	NW25
Noise	<59 dB(A)
Minimum cooling water flow rate	2 lmin ⁻¹
Cooling water temperature	15 – 35 °C
Electrical Supply	200/208 V, 50/60 Hz 3 phase
Power at ultimate	1.4 kW
Rated motor power	3.0 kW
TIM	C3
Weight	45.2 kg

Ordering Information

Product Description	Order No.
EPX500L Dry Pump 208V SPI TIM 3/8 water connector	A41951212
EPX500L Dry Pump 400V SPI TIM 3/8 water connectors	A41951214
EPX500L Dry Pump 208V SPI TIM 1/4 water connector	A41951222
EPX500L Dry Pump 400V E73 TIM 3/8 water connectors	A41951314
EPX500L Dry pump 400V LAM TIM 3/8 water connectors	A41951514
EPX500L Dry Pump 400V MCM TIM No water connectors	A41951704
EPX500L Dry pump 208V MCM TIM 3/8 water connector	A41951712
EPX500L Dry pump 400V MCM TIM 3/8 water connectors	A41951714
EPX500L Dry Pump 208V C3 TIM 3/8 water connector	A41951112
EPX500L Dry Pump 200V	A41951002
EPX500L Dry Pump 400V	A41951004
EPX500L Dry Pump 400V SPI TIM 3/8 water connectors	A41951014

EPX500LE Dry pump



The new compact EPX500 high vacuum drypump offers enhanced performance with reduced cost of ownership. Using a unique patent protected mechanism the EPX500 is capable of pumping from atmosphere to ultimate pressures of $<7 \times 10^{-5}$ Torr.

Based on the successful award winning IPX range, the modular EPX500 offers outstanding performance in a package that is 20% lighter, 30% smaller and requires 40% less power than the IPX.

Features & Benefits

- Compact footprint - as one of the smallest on-tool pumps available, the EPX offers outstanding savings in footprint. EPX can be mounted directly onto the tool saving foreline and installations costs or remotely if preferred.
- Low cost of ownership - EPX requires only 1.4 kW of power and incorporating idle mode to maximize power efficiency.
- Unique patent protected pumping mechanism - the EPX can pump down from atmosphere to turbomolecular base pressure and can operate continuously at all inlet pressures.
- Ultra clean mechanism - conventional high vacuum bearings under grease use grease lubrication which can be a source of contamination in process tools. EPX pumps have no high vacuum bearings under grease and present no other source of potential contamination.
- Extremely reliable - based on field proven IPX technology, the EPX has a $MTBF_p = 13$ years (SEMI E10) with service periods of around every 5 years to maximize the life of the pump.

Applications

- The EPX series covers a broad range of applications from wafer handling through to medium duty processes. The EPX 'LE' Series has been designed for use clean duty applications pumping inert gas mixtures, such as loadlock, whereby control is provided by the process tool interface.

Dimensions

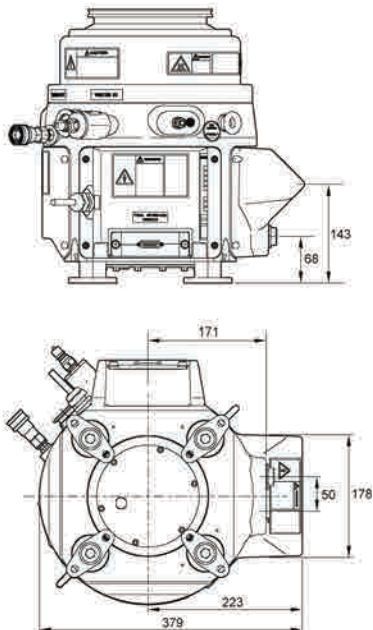

H = 388 (EPX180) H = 397 (EPX500)

Performance Curves

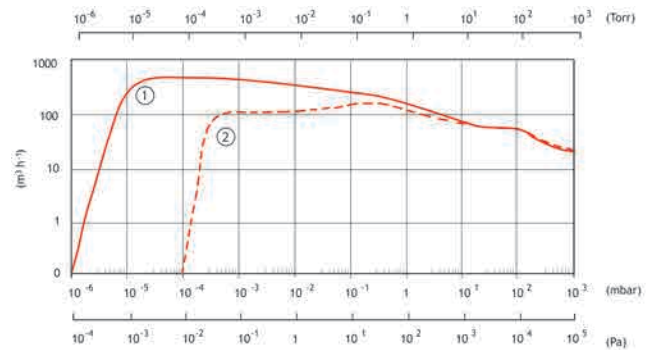

1. EPX500 2. EPX180

Technical Data

Peak speed	500 m ³ h ⁻¹ 295 ft ³ min ⁻¹ 8338 l min ⁻¹
Ultimate vacuum	<1 x 10 ⁻⁶ mbar <7.5 x 10 ⁻⁷ Torr <1 x 10 ⁻⁴ Pa
Warm-up time (to nominal performance)	30 min
Inlet flange	ISO160
Outlet flange	NW25
Noise	<59 dB(A)
Minimum cooling water flow rate	2 l min ⁻¹
Cooling water temperature	15 – 35 °C
Electrical Supply	200/208 V, 50/60 Hz 3 phase
Power at ultimate	1.4 kW
Rated motor power	3.0 kW
TIM	None
Weight	45.2 kg

Ordering Information

Product Description	Order No.
EPX500LE Dry pump 208V No TIM 3/8 water connector	A41953012
EPX500LE Dry pump 400V No TIM 3/8 water connectors	A41953014
EPX500LE Dry pump 208V E73 TIM 3/8 water connector	A41953312
EPX500LE Dry pump 208V TEL TIM 3/8 water connector	A41953412
EPX500LE Dry pump 208V MCM TIM 3/8 water connector	A41953712

EPX500N Dry Pump



The new compact EPX500 high vacuum drypump offers enhanced performance with reduced cost of ownership. Using a unique patent protected mechanism the EPX500 is capable of pumping from atmosphere to ultimate pressures of $<7 \times 10^{-5}$ Torr.

Based on the successful award winning IPX range, the modular EPX500 offers outstanding performance in a package that is 20% lighter, 30% smaller and requires 40% less power than the IPX.

Features & Benefits

- Compact footprint - as one of the smallest on-tool pumps available, the EPX offers outstanding savings in footprint. EPX can be mounted directly onto the tool saving foreline and installations costs or remotely if preferred.
- Low cost of ownership - EPX requires only 1.4 kW of power and incorporating idle mode to maximize power efficiency.
- Unique patent protected pumping mechanism - the EPX can pump down from atmosphere to turbomolecular base pressure and can operate continuously at all inlet pressures.
- Ultra clean mechanism - conventional high vacuum bearings under grease use grease lubrication which can be a source of contamination in process tools. EPX pumps have no high vacuum bearings under grease and present no other source of potential contamination.
- Extremely reliable - based on field proven IPX technology, the EPX has a $MTBF_p = 13$ years (SEMI E10) with service periods of around every 5 years to maximize the life of the pump.

Applications

- Load Lock
- Transfer Chamber
- PVD sputtering
- Ashing/PR Strip
- Dielectric Etch

Dimensions

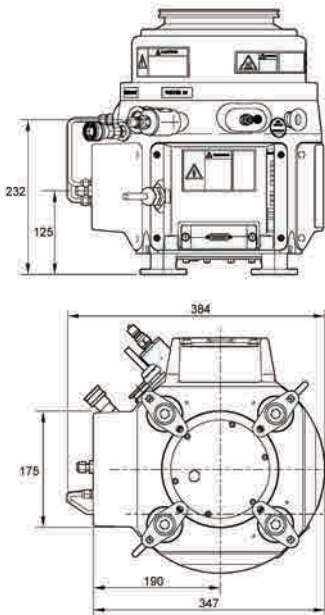

H = 388 (EPX180) H = 397 (EPX500)

Performance Curves

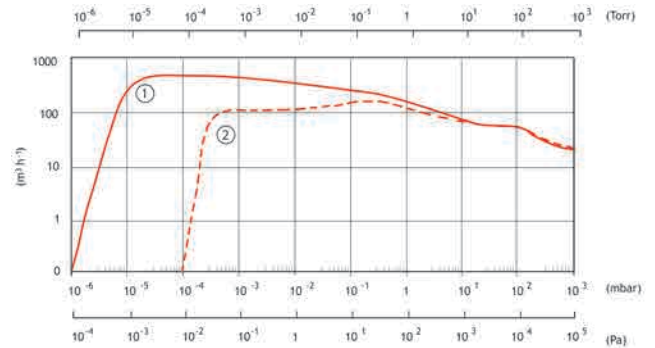

1. EPX500 2. EPX180

Technical Data

Peak speed	500 m ³ h ⁻¹ 295 ft ³ min ⁻¹ 8338 lmin ⁻¹
Ultimate vacuum	<1 x 10 ⁻⁶ mbar <7.5 x 10 ⁻⁷ Torr <1 x 10 ⁻⁴ Pa
Warm-up time (to nominal performance)	30 min
Inlet flange	ISO160
Outlet flange	NW25
Noise	<59 dB(A)
Minimum cooling water flow rate	2 lmin ⁻¹
Cooling water temperature	15 – 35 °C
Nitrogen supply interface	1/4 in (6.5 mm) tube
Nitrogen supply pressure	3 x 10 ⁵ – 7 x 10 ⁵ Pa
Minimum nitrogen purity	99.95%
Electrical Supply	200/208 V, 50/60 Hz 3 phase
Power at ultimate	1.4 kW
Rated motor power	3.0 kW
TIM	C3
Weight	45.2 kg

Ordering Information

Product Description	Order No.
EPX500N Dry pump 208V C3 TIM 3/8 water connector	A41952112
EPX500N Dry pump 208V SPI TIM 3/8 water connector	A41952212
EPX500N Dry pump 208V SPI TIM 1/4 water connector	A41952222
EPX500N Dry pump 400V TEL TIM 3/8 water connectors	A41952414
EPX500N Dry pump 208V TEL TIM 1/4 water connector	A41952422
EPX500N Dry pump 208V MCM TIM 3/8 water connector	A41952712
EPX500N Dry pump 400V, 3/8 water connector	A41952014

EPX500NE Dry pump



The new compact EPX500 high vacuum drypump offers enhanced performance with reduced cost of ownership. Using a unique patent protected mechanism the EPX500 is capable of pumping from atmosphere to ultimate pressures of $<7 \times 10^{-5}$ Torr.

The EPX NE series of pumps has an End User Controller (EUC). The End User Controller enables local control for stand-alone use as well as the ability to connect to a fab-wide network for remote control and monitoring.

Features & Benefits

- Compact footprint - as one of the smallest on-tool pumps available, the EPX offers outstanding savings in footprint. EPX can be mounted directly onto the tool saving foreline and installations costs or remotely if preferred.
- Low cost of ownership - EPX requires only 1.4 kW of power and incorporating idle mode to maximize power efficiency.
- Unique patent protected pumping mechanism - the EPX can pump down from atmosphere to turbomolecular base pressure and can operate continuously at all inlet pressures.
- Ultra clean mechanism - conventional high vacuum bearings under grease use grease lubrication which can be a source of contamination in process tools. EPX pumps have no high vacuum bearings under grease and present no other source of potential contamination.
- Extremely reliable - based on field proven IPX technology, the EPX has a $MTBF_p = 13$ years (SEMI E10) with service periods of around every 5 years to maximize the life of the pump.

Applications

- Load Lock
- Transfer Chamber
- PVD sputtering
- Ashing/PR Strip
- Dielectric Etch

Dimensions

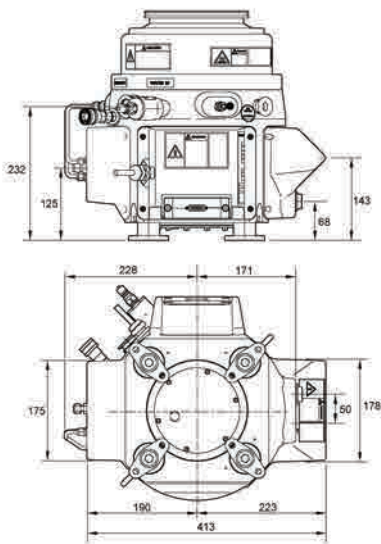

H = 388 (EPX180) H = 397 (EPX500)

Performance Curves

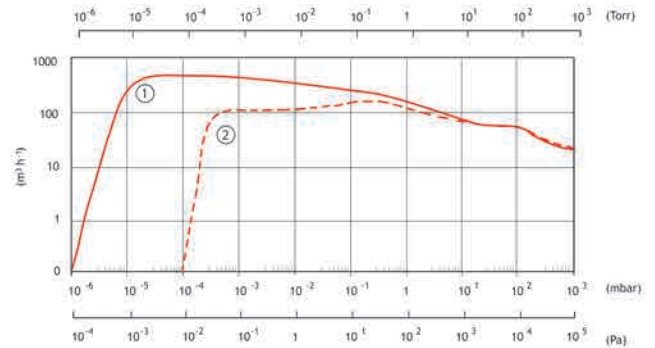

1. EPX500 2. EPX180

Technical Data

Peak speed	500 m ³ h ⁻¹ 295 ft ³ min ⁻¹ 8338 lmin ⁻¹
Ultimate vacuum	<1 x 10 ⁻⁶ mbar <7.5 x 10 ⁻⁷ Torr <1 x 10 ⁻⁴ Pa
Warm-up time (to nominal performance)	30 min
Inlet flange	ISO160
Outlet flange	NW25
Noise	<59 dB(A)
Minimum cooling water flow rate	2 lmin ⁻¹
Cooling water temperature	15 – 35 °C
Nitrogen supply interface	1/4 in (6.5 mm) tube
Nitrogen supply pressure	3 x 10 ⁻⁵ – 7 x 10 ⁻⁵ Pa
Minimum nitrogen purity	99.95%
Electrical Supply	200/208 V, 50/60 Hz 3 phase
Power at ultimate	1.4 kW
Rated motor power	3.0 kW
TIM	None
Weight	45.2 kg

Ordering Information

Product Description	Order No.
EPX500NE 208V No TIM 3/8 water connector	A41954012
EPX500NE 400V No TIM 3/8 water connector	A41954014
EPX500NE 208V No TIM 1/4 water connector	A41954022
EPX500NE 208V SPI TIM 3/8 water connector	A41954212
EPX500NE 400V SPI TIM 1/4 water connectors	A41954224
EPX500NE 208V TEL TIM 3/8 water connector	A41954412
EPX500NE 400V TEL TIM 3/8 water connectors	A41954414
EPX500NE 400V TEL TIM 1/4 water connectors	A41954424
EPX500NE 208V LAM TIM 3/8 water connector	A41954512
EPX500NE 208V MCM TIM 3/8 water connector	A41954712
EPX500NE 400V MCM TIM 3/8 water connectors	A41954714

GX100 Dry Pump



The GX Dry Vacuum Pump Series sets new standards for zero maintenance between major overhauls. Improved efficiency lowers the cost of ownership and provides continuous pumping duty throughout the pressure range.

GX pumps are available in a wide range of peak speeds and variants to address applications from clean through to medium-duty processes. A modular design allows users to configure GX drypumps to suit individual fab requirements. An ultra-compact footprint allows installation options including on-tool, close proximity, or remote.

Features & Benefits

- Reduced Cost of Ownership
- Up to a 50% reduction in utilities cost compared to iL/iH drypumps
- No preventative maintenance
- Flexible Installation Options
- Small and light for easy installation

Applications

- Load Lock
- Transfer
- Metrology

Dimensions

GX100 Side View

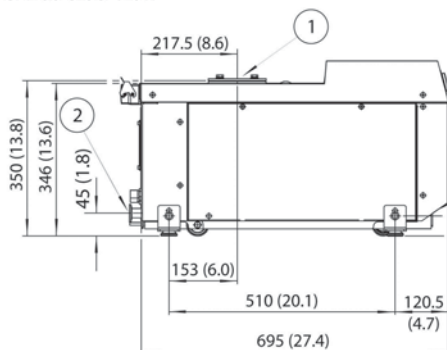

1. Inlet flange

2. Exhaust flange

GX Top View

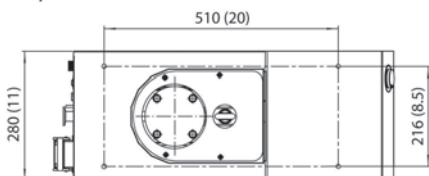

Performance Curves

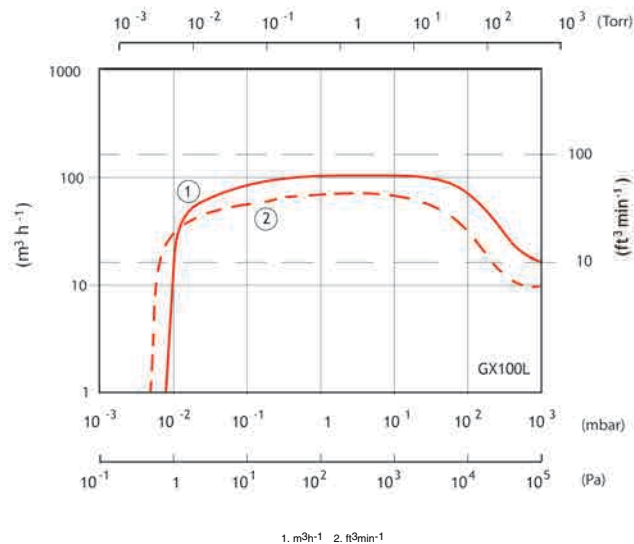

1. 1 m³ h⁻¹ 2. 0.5 m³ h⁻¹

Technical Data

Performance

Peak speed	105 m ³ h ⁻¹
	62 ft ³ min ⁻¹
	1750 lmin ⁻¹
Ultimate pressure	5 x 10 ⁻³ mbar
	3.75 x 10 ⁻³ Torr
	0.5 Pa

Power at 700 Torr exhaust

Ultimate	1 kW
AUC (Active Utility Controller)	0.05 kW
Water *	
Water inlet	1 slm
Nitrogen	0 slm

Installation Details

Footprint (excluding exhaust)	0.20 m ²
Weight	120 kg
Inlet connection	ISO 63
Outlet connection	NW25
Noise at ultimate	<55 dB(A)

* Requires Constant Flow Valve accessory

Ordering Information

Product Description	Order No.
GX100L Dry Pump 200-230 V 50/60 Hz	A54710958
GX100L Dry Pump 380-460 V 50/60 Hz	A54710959
GX100TI Dry Pump 200-230 V 50/60 Hz	A54746958
GX100N Dry Pump 200-230 V 50/60 Hz	A54711958
GX100N Dry Pump 380-450 V 50/60 Hz	A54711959

GX600 Dry Pump



The GX Dry Vacuum Pump Series sets new standards for zero maintenance between major overhauls. Improved efficiency lowers the cost of ownership and provides continuous pumping duty throughout the pressure range.

GX pumps are available in a wide range of peak speeds and variants to address applications from clean through to medium-duty processes. A modular design allows users to configure GX drypumps to suit individual fab requirements. An ultra-compact footprint allows installation options including on-tool, close proximity, or remote.

Features & Benefits

- Reduced Cost of Ownership
- Up to a 50% reduction in utilities cost compared to iL/iH drypumps
- No preventative maintenance
- Flexible Installation Options
- Small and light for easy installation

Dimensions

GX300, 600, 1000 Side View

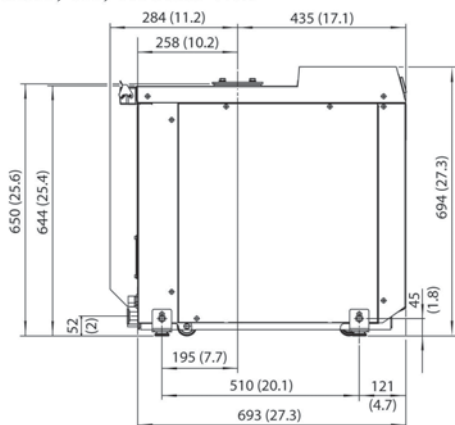

GX Top View

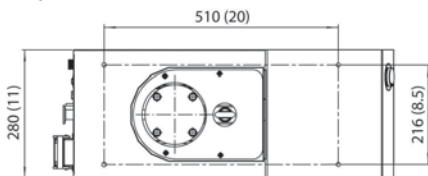

Applications

- Load Lock
- Transfer
- Metrology

Performance Curves

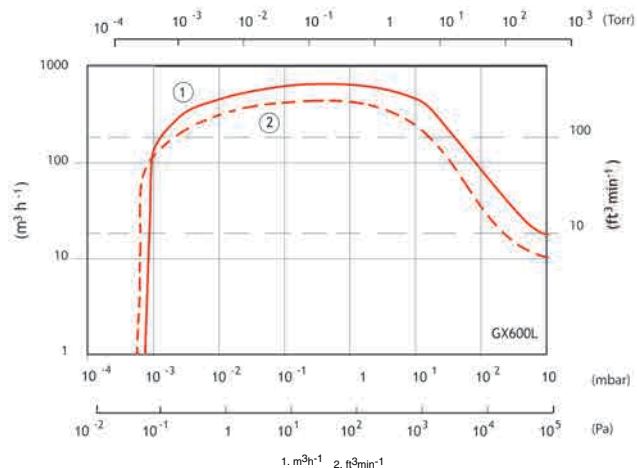

Technical Data

Performance

Peak speed	620 m ³ h ⁻¹
	365 ft ³ min ⁻¹
	10333 lmin ⁻¹
Ultimate pressure	7 x 10 ⁻⁴ mbar
	5.25 x 10 ⁻⁴ Torr
	0.07 Pa

Power at 700 Torr exhaust

Ultimate	1.6 kW
AUC (Active Utility Controller)	0.05 kW
Water *	
Water inlet	2 slm
Nitrogen	0 slm

Installation Details

Footprint (excluding exhaust)	0.20 m ²
Weight	220 kg
Inlet connection	ISO 100
Outlet connection	NW25
Noise at ultimate	<55 dB(A)

* Requires Constant Flow Valve accessory

Ordering Information

Product Description	Order No.
GX600L Dry Pump 200-230 V 50/60 Hz	A54730958
GX600L Dry Pump 380-460 V 50/60 Hz	A54730959
GX600N Dry Pump 200-230 V 50/60 Hz	A54731958
GX600N Dry Pump 380-450 V 50/60 Hz	A54731959

GX1000 Dry Pump



The GX Dry Vacuum Pump Series sets new standards for zero maintenance between major overhauls. Improved efficiency lowers the cost of ownership and provides continuous pumping duty throughout the pressure range.

GX pumps are available in a wide range of peak speeds and variants to address applications from clean through to medium-duty processes. A modular design allows users to configure GX drypumps to suit individual fab requirements. An ultra-compact footprint allows installation options including on-tool, close proximity, or remote.

Features & Benefits

- Reduced Cost of Ownership
- Up to a 50% reduction in utilities cost compared to iL/iH drypumps
- No preventative maintenance
- Flexible Installation Options
- Small and light for easy installation

Dimensions

GX300, 600, 1000 Side View

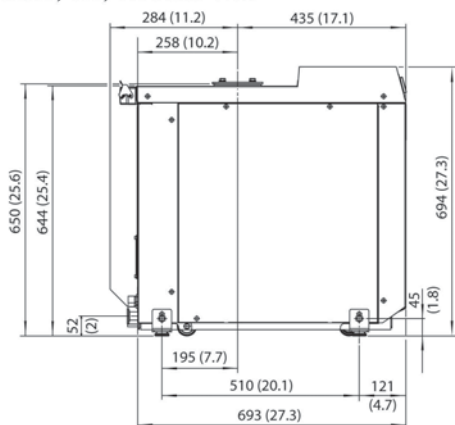

GX Top View

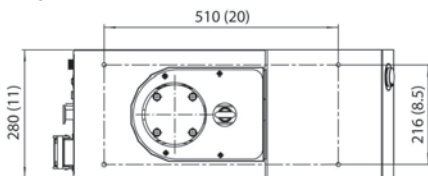

Applications

- Load Lock
- Transfer
- Metrology
- Lithography
- PVD Process

Performance Curves

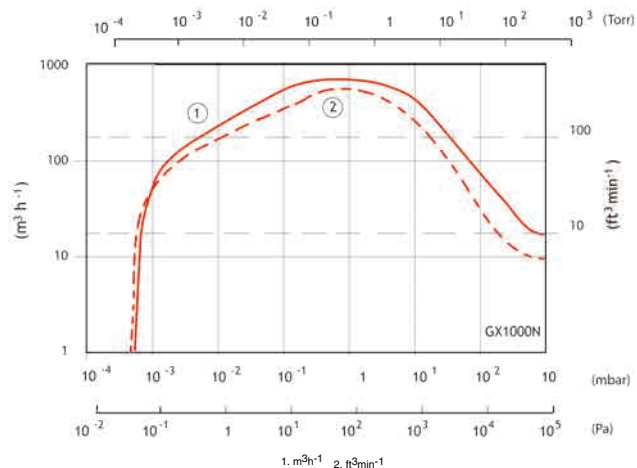

Technical Data

Performance	
Peak speed	800 m ³ h ⁻¹ 471 ft ³ min ⁻¹ 13333 lmin ⁻¹
Ultimate pressure	1 x 10 ⁻³ mbar 7.5 x 10 ⁻⁴ Torr 0.10 Pa
Power at 700 Torr exhaust	
Ultimate	1.6 kW
AUC (Active Utility Controller)	1.05 kW
Water *	
Water inlet	2 slm
Nitrogen	4 or 14 slm **
Installation Details	
Footprint (excluding exhaust)	0.20 m ²
Weight	230 kg
Inlet connection	ISO 100
Outlet connection	NW25
Noise at ultimate	<55 dB(A)

* Requires Constant Flow Valve accessory

** Nitrogen purge can be manually adjusted to a maximum flow of 39slm

Ordering Information

Product Description	Order No.
GX1000N Dry Pump 200-230 V 50/60 Hz	A54781958
GX1000N Dry Pump 380-460 V 50/60 Hz	A54781959

Exhaust Management for Semiconductor Processes

Comprehensive Range

Edwards is unique in offering the broadest range of exhaust management technologies, demonstrated in a series of products and systems designed to meet all customer requirements – from low-cost facility management to full environmental protection. We are committed to supplying exhaust management systems that match customer specific application requirements. We strive to minimise cost of ownership while introducing innovative designs to achieve greater reliability, longer service intervals, reduced space and utilities requirements and lower waste emissions.

Leading-Edge Manufacturing

Our primary manufacturing facility is located at Clevedon in the UK. The site comprises a factory with flexible production lines, assembly feed cells, just-in-time manufacturing techniques and one of the largest exhaust management research centers in the world. Additional manufacturing sites located at Chunan (Korea) and Ina (Japan) complement the global production capability. Underpinning our whole operation is a commitment to quality and world class manufacturing standards. An ISO 9001 and ISO 14001 management system, supported by TQM and Kaizen methodologies, is at the core of the operation. Product certification to the relevant international standard is conducted by ITS, the independent external test house.

Thermal Processing

Effective exhaust management of CVD processes must be able to handle the deposition gases and the associated powders. The fluoride wastes from cleaning gases also require suitable treatment along with the global warming gases. Abatement systems must be able to comply with these requirements in one complete unit.

The TPU (Thermal Processing Unit) is the industry standard abatement system for CVD. One model is suitable for all CVD and many etch applications. Each inlet can be configured for high level abatement of all Global Warming PFC gases, F₂ or ClF₃. The TPU can accommodate total input flows up to 280 slpm.

Where PFCs are not used, the TCS (Thermal Conditioning System) provides a cost-effective means of handling both hazardous fluoride waste and deposition gases.

The Helios is an advanced solution for the abatement of high hydrogen flows designed to handle both toxic and carrier gases from Low Pressure Epitaxy and MOCVD processes.

Atlas The Atlas range is the latest addition to the inward fired combustor range available in TPU, TCS and Kronis variants, the range offers the same excellent performance with added benefits of reduced utilities and cost of ownership savings as standard.

The Kronis provides effective treatment for low k CVD process exhausts.

The HOx (Hot Oxidation System) offers an innovative electrical heated oxidation unit and the proven three-stage wet scrubber of the combustor product line, it combines superior performance for the abatement of CVD processes in facilities which do not have the ability to use fuel gas.



GRC technology has been used to abate the exhaust gas streams on a wide range of semiconductor applications. (Photograph courtesy of TI, Dallas, USA.)

Gas Reactor Columns

Edwards offers a range of low-cost, point-of-use dry abatement systems for semiconductor processing. Each system uses the unique hot bed reactor technology developed for the GRC (Gas Reactor Column) range. The Inline 250 is the highest performance of any dry abatement technology for etch exhausts. It provides treatment by chemical reaction to stable inert salts and treats the widest range of gases from halogens and acids to ClF₃, NF₃, SF₆ and other halide etch compounds. The D150 Dual GRC provides dual-cartridge operation thus minimising the cost of ownership with 100% uptime. The M150 Single GRC is a compact dry gas treatment system for removing hazardous etch and CVD emissions at the source, converting them into harmless solids within an easily changed and disposable cartridge.

Wet Scrubbers

Edwards new range of wet scrubbers provide exhaust management at minimal cost for preservation of assets and regulatory compliance.

Tempest is a point of use wet scrubber suitable for the treatment of semiconductor process tool exhausts containing water-soluble and water-reactive gases such as HCl, Cl₂ and NH₃.

Pyrophoric Conditioning

For the removal of silane and pyrophoric gases to below lower explosion level (LEL) the PCS (Pyrophoric Conditioning System) offers an advanced solution. Specifically designed for the safe handling of silane, the PCS incorporates a unique particle handling system to keep ducts free from powders.

Integrated Vacuum and Exhaust Management Systems

Vacuum equipment and exhaust management devices are traditionally installed side-by-side, beneath the process tool. The Zenith range now offers a series of process-specific, fully integrated vacuum pump and exhaust management systems designed to safely handle the process exhausts from a wide range of applications. Enhanced safety, process tool compatibility, minimum footprint and reduced cost of ownership are key benefits derived from our unique approach, resulting in improved uptime, process efficiency and profitability.

TMS Temperature Management System

Edwards offers TMS (Temperature Management System) for processes involving condensable byproducts. TMS ensures that these compounds remain volatile until they enter the abatement device. The TMS is designed to heat both forelines and pump exhaust lines to the inlet of the abatement device. Moulded high surface area heaters maximize contact with pipes and are designed to maintain the temperature of the pipe between 90° and 150 °C. TMS monitoring is available as an option to provide both local and remote verification that the line is at a sufficient temperature. TMS has been successfully used in conjunction with the entire range of Edwards exhaust management equipment to alleviate the problems historically associated with solid deposition and corrosion.

Product Selection

Using our product selection guide customers have the opportunity to decide which Edwards point-of use abatement equipment is most suitable for their particular application on the basis of their exhaust gas management goals. Edwards will provide their experience and expertise to specify the exhaust management product for the chosen application.

This page is intentionally left blank.

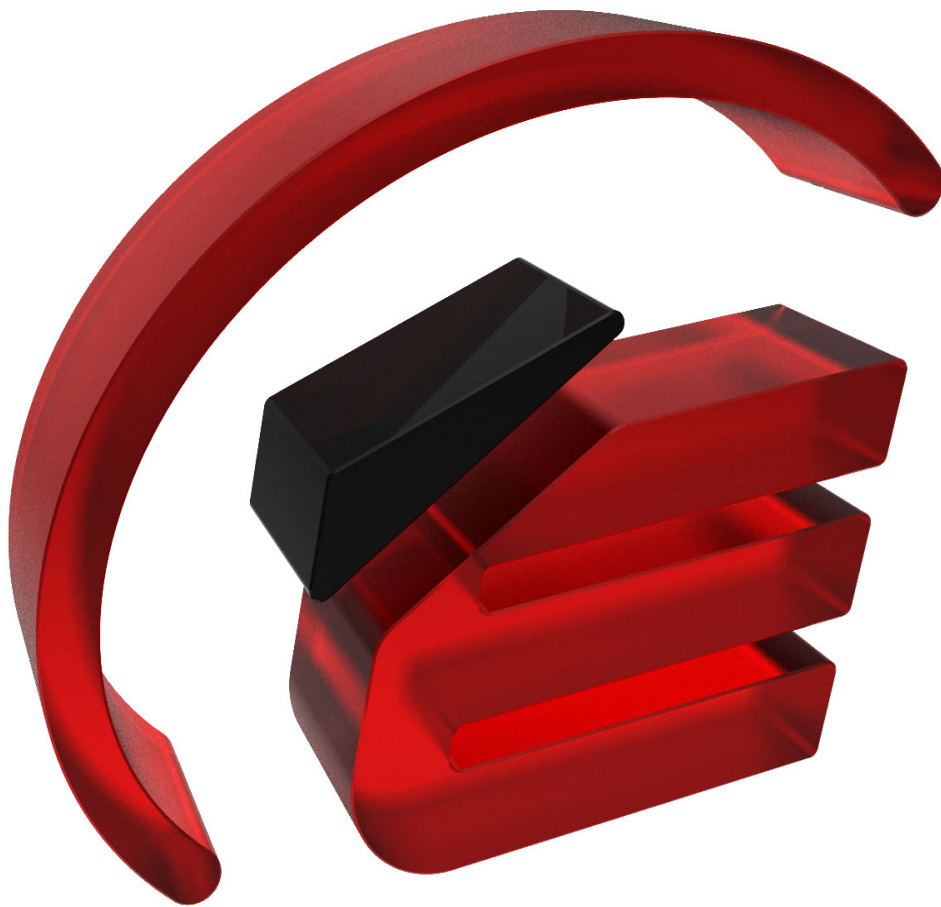

7

Page
274

Industrial Pumps and Pumping Systems



GXS Dry Pumps	280
Drystar 80 Pumps	288
IDX Dry pumps	290
Medium and Large EM Oil Sealed Rotary Vane Pumps	294
Large Pump Accessories	302
Stokes Microvac Series Oil Sealed Pumps	308
Stokes Microvac Accessories	312
MB/MV Series Vertically Oriented Booster Combinations	315
Stokes Microvac / 6" Booster combinations	316
Stokes 1700 Series Mechanical Booster Combinations	319
EV Single Stage Oil Sealed Rotary Vane Pumps	340
Accessories for Single Stage Oil Sealed Pumps	349
EV Single Stage Oil Sealed Pump Combinations	350
EH Mechanical Booster Pumps	353
Mechanical Booster Pump Accessories	363
Stokes 6" Series Mechanical Booster Pumps	365
HV Mechanical Booster Pumps	373

Large Pumps and Pumping Systems

Introduction

Edwards range of industrial dry pumps, oil sealed rotary pumps, oil sealed piston pumps and mechanical boosters are the most comprehensive available to the industrial user. Add our extensive range of accessories and the pumps can be configured for a wide range of applications. The pumps and accessories can be supplied either as individual components or as fully systemized, factory tested combinations.

The range consists of:

- GXS dry pumps
- IDX dry pumps
- Drystar® 80 dry pumps
- EM oil sealed rotary vane pumps
- Stokes Microvac oil sealed piston pumps
- EV oil sealed rotary vane pumps
- EH, Stokes Vacuum 6" and HV booster pumps

GXS Dry Pumps



Edwards, a pioneer in dry pumping technology, launches a new generation of dry pumps for industrial applications.

Edwards has over 90 years of experience in harsh process vacuum applications, including dust and process contaminants handling, with more than 150,000 dry pumps installed worldwide.

The GXS industrial dry screw pump incorporates innovative, patented design features that establish a new standard in dry pumping.

Fast - Dry pumping down to 5×10^{-4} mbar / 3.7×10^{-4} Torr ultimate vacuum (without purge)

Robust - Reliable operation in harsh industrial applications

Compact - Smaller footprint than pumps of similar capabilities

Economical - Affordable capital investment and low cost of ownership

Environmental - Smooth, quiet running with low power and utilities consumption

IDX and Drystar® 80 Dry Pumps



The Drystar® 80 is based on the well proven Edwards reverse claw mechanism reaching a peak speed of $560 \text{ m}^3\text{h}^{-1}$ / $330 \text{ ft}^3\text{min}^{-1}$. The reverse claw mechanism results in short gas paths within the operating mechanism, providing the ability to handle large amounts of dust and water vapour, when compared to oil sealed pumps, without deterioration of performance.

The IDX 1000 and 1300 use the latest double ended screw technology to provide a peak speed of up to $1300 \text{ m}^3\text{h}^{-1}$ / $767 \text{ ft}^3\text{min}^{-1}$. Many features are patented and as with the GV range are able to handle large amounts of dust and water vapour with little or no effect on performance.

- Low cost of ownership in harsh conditions
- High reliability – dry mechanism proven in 100,000 installations
- Oil free mechanism – reduced maintenance
- Higher dust and water vapour tolerance
- Accessories to optimise pump performance to process variables
- Fast pump down with Edwards hydrokinetic drive booster pumps.

EM Oil Sealed Rotary Pumps



Edwards rugged two stage mechanical oil sealed pumps are available in sizes from 40 - $275 \text{ m}^3\text{h}^{-1}$ / 30 - $206 \text{ ft}^3\text{min}^{-1}$. They feature:

- Advanced oil lubrication circuit
- High reliability
- Accessories to match your application needs

Stokes Microvac Oil Sealed Rotary Piston Pumps



Stokes Microvac oil sealed piston pumps are available in sizes 255 - $1240 \text{ m}^3\text{h}^{-1}$ / 150 - $728 \text{ ft}^3\text{min}^{-1}$. They feature:

- Proven rugged robust design
- Internal oil piping to eliminate potential leaks
- Oil sight glass and flow indicator to provide easy monitoring of oil level and flow
- O-ring sealed covers to eliminate potential oil leaks
- Integral gas ballast valve

EV Oil Sealed Single Stage Rotary Vane Pumps



Oil sealed rotary vane pumps 20 to 630 m³h⁻¹ / 11 to 360 ft³min⁻¹. Standard features include:

- Dual frequency, wide band motor operates in most countries worldwide
- Efficient mist filter for economical operation and environmental protection
- Integral anti suckback valve protected by fine mesh filter
- Gas ballast valve
- High pumping speed at low pressure
- Ultimate vacuum better than 0.5 mbar
- Continuously rated at any pressure from atmosphere to ultimate
- Fine mesh inlet filter

The new EV range of vacuum pumps provides an economical solution for industrial applications where high ultimate vacuums are not required.

EH Mechanical Booster Pumps



The EH mechanical booster pumps feature the unique hydrokinetic drive, providing an efficient power transmission with benefits in economy, performance and compactness. The hydrokinetic drive provides the following features:

- Capacities for 250 to 4200 m³h⁻¹
- Pump down times cut by 50%, when compared with direct drive pumps
- No bypass lines or pressure switches required
- Reduced capital and operating costs
- Air cooled motors
- Quiet, minimum vibration

Stokes 6" Series Mechanical Booster Pumps



Stokes 6" series mechanical booster pumps are available in sizes 1020-5100 m³h⁻¹ / 600-3000 ft³min⁻¹. Features include:

- Rugged design for reliable and extended operation
- Simple maintenance features incorporated in design
- Options of direct drive motors or bare shaft machines
- Options of 5 seal process isolation boosters for optimum protection from dust and particulate
- Options of by pass technology to reduce pump down time
- Dynamically balanced impellers

HV8000 Industrial, ATEX and Explosion Proof Mechanical Booster Pumps

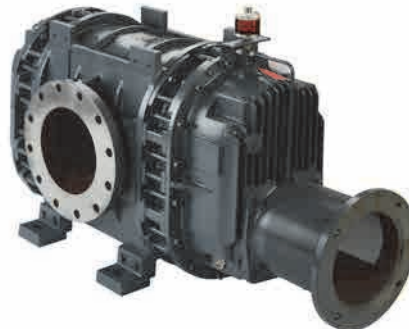

The Edwards HV8000 high vacuum mechanical booster has a nominal pumping speed of 7200 m³ h⁻¹ (4241 ft³ min⁻¹), at 50 Hz.

- Derived from the successful range of SN pressure blowers, the HV8000 booster is designed for arduous duty cycles and high power applications.
- Ideal for larger scale harsh industrial and chemical applications, HV boosters are available in Industrial, ATEX or Explosion Proof configurations.
- HV boosters may be ordered as either 'bareshaft' or with motor fitted. Variable frequency drives may be specified for greater versatility.
- HV boosters are available in vertical or horizontal gas flow configuration.
- For long service life, the external shaft seal is water-cooled.
- Five bearing construction and rugged helical gears make for a very robust construction.

HV Mechanical Booster Pumps



The HV30000 direct drive mechanical booster has a pumping speed of up to 36000 m³h⁻¹ / 21204 ft³min⁻¹ at 60 Hz. The speed of the pump motor can be controlled by an inverter.

In addition, the pumps offer the following features:

- Water cooled shaft seals and after cooler
- Fitted with thermal snap-switch, to protect the pump from over temperature
- Nitrogen purge inlet fitted as standard
- Vertical flow, direct drive
- Control with inverter, or interlock with a pressure switch input.

Systemization

Edwards comprehensive range of pumps forms the basis for the manufacture of factory tested combination systems, with displacements from 310 m³h⁻¹ to 30000 m³h⁻¹ / 180 ft³min⁻¹ to 17700 ft³min⁻¹. With a wide and robust range of accessories to choose from, the pumping system can be optimised for your application. Edwards systemization service offers fully factory tested combinations with appropriate accessories.

GXS, IDX and Drystar® 80 Pumps

Edwards is a market leader in dry pump technology and has pioneered the use of dry vacuum in some of the harshest applications.

The Edwards GXS range incorporates our unique screw technology with a world leading high efficiency drive to achieve excellent vacuum performance with low running costs.

The IDX uses the very latest in double ended screw pumping technology, whilst the Drystar 80 range utilises a reverse claw mechanism, proven over more than 10 years and 100,000 installations worldwide. Both provide reliable and economical solutions to the demands of today's industrial processes.



All Edwards dry pump ranges are ideally suited to:

- Metallurgy
 - Vacuum Induction Melting (VIM)
 - Precision Investment Casting (PIC)
 - Vacuum Arc Refining (VAR)
 - Electron beam welding
 - Vacuum sintering
 - Steel degassing
- LED manufacture
- Lithium Battery manufacture
- Solar
 - Lamination
 - Silicon Crystal growing
 - Solar coating
- Heat treatment
 - Hardening
 - Plasma & LP nitriding
 - LP carburization
 - Vacuum brazing
- Coating
 - Roll coating
 - Architectural glass coating
 - Optical filters & lenses
 - Vacuum metallising
- Drying
 - Lithium Ion Battery (Drying and Degassing)
 - Transformers, capacitors & cables
 - Leather
 - Spices & fragrances
 - Nuclear industry

and many more.

With such a range of pumping speeds combinations and applications available, Edwards retains a comprehensive Applications Engineering capability and are able to offer a solutions package that includes:

- Process design
- Equipment specification and selection
- Safety and operating procedures
- Vacuum system and control integration
- Commissioning advice

Solutions Engineering

The range and complexity of industrial applications means a 'one size fits all' policy does not result in system optimization. A detailed appreciation of the process, environmental and safety issues is required to tailor systems to match performance and process.

Applications Design & Support Edwards comprehensive design service is based on in-depth knowledge of the industries and applications involved. This expertise is held in the highly focused and experienced applications team, which consists of a Central Applications Group supported by a regional network of Applications Specialists. Proprietary software is used to define pumping requirements and a suite of optional accessories or modules are available. For larger or more unusual applications a custom engineering service is available.

Solutions could cover:

- Process design
- Equipment selection
- Safety and Operating Parameters
- Integration with plant control system(s)
- Commissioning advice and more...

Contact your local office to request an initial discussion with an Applications Specialist. Typically, discussions will include gases / materials to be pumped, cycle times and duty pressures, system capacities, control systems, utilities, system footprint and all other aspects of the vacuum system to ensure that we are able to offer the most effective solution for your application.

The product range is available from $80 \text{ m}^3\text{hr}^{-1} / 47 \text{ ft}^3\text{min}^{-1}$ to $3450 \text{ m}^3\text{hr}^{-1} / 2031 \text{ ft}^3\text{min}^{-1}$.

Why Dry?

Dry Vacuum pumps - why not you? The competitive nature of today's business means changes are required to improve performance, lower costs, and provide optimal process solutions. The Dry pumping solution is the change from traditional oil sealed pumps to a proven technology for this industry. Edwards, a world leader in dry pump technology, has demonstrated the ability to provide a low-cost, custom tailored solution to your vacuum application. The benefits offered by the GXS/Drystar 80/IDX Dry pumping solutions are:

- Maintenance
 - Low capital cost and minimal maintenance requirements lead to lowest cost of ownership
 - Extended periods between user intervention
 - Lower consumable costs
- Environmental
 - No oil disposal
 - No oil emissions into atmosphere
- Performance
 - Very stable pumping speed gives repeatability to processes
 - Continuous pumping at atmosphere
 - Ability to handle particulates
 - Dry eliminates back-streaming, thus protecting reactive alloys from contamination
 - Significantly higher capacity for water vapour pumping than traditional oil sealed pumps
- Safety
 - Unobtrusive noise levels
 - No unsightly oil spills
 - No hazardous oil vapours

GXS industrial Dry Screw Pump

Designed for high reliability Edwards patented screw-rotor design delivers excellent pumping speed and is part of an advanced thermal management system that maximizes pump performance and life of the seals, bearings, and motor to ensure long pump service life.

Adaptable to a wide range of applications GXS pumps are offered with a range of purge options, filters, catchpots, inlet isolation valves and silencers; together with our special high flow purge and solvent flush accessory enabling the inside of the pump to be kept clean without disassembly.

Long service intervals and easy swap-out Long-life non-oxidizing gearbox oil enables service intervals of up to 5 years to be achieved. Quick-connect utility interfaces provide for rapid pump installation and exchange to improve factory up-time.

Low cost of ownership Custom high-efficiency motor and drive system with advanced seal technology provides for greatly reduced power consumption. Minimal cooling water and purge gas requirements coupled with improved powertrain technology provide for long service intervals and near maintenance-free operation.

Minimum workplace and environmental impact GXS pumps are incredibly compact. Edwards advanced screw-rotor design provides for remarkably quiet, low vibration operation even without a silencer.

Simple to install and operate GXS pumps are easily wheeled or fork-lifted into position, coupled to the process and services using the supplied mating connectors and run at the push of a button.

Ideal for integration into larger systems GXS pumps and combinations are supplied with serial (RS232) communication and LAN-based web-serving capability as standard. Optional modules are available to add Parallel (digital I/O) and Profibus control functionality.

At your service Edwards has highly skilled applications specialists who will advise on the optimum configuration for your process or application.

GXS innovative technology

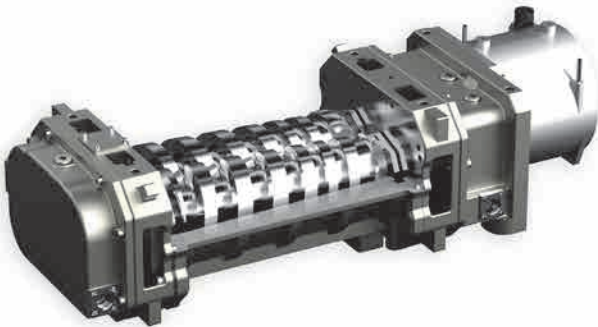

Bearing and Lubrication

- Oil lubricated gears eliminate grease and the need for periodic maintenance.
- Advanced quality bearings and special purpose oil is used, with low vapour pressure for application compatibility and greatly improved life.

Double ended shaft support

- Non-cantilever design provides secure rotor support for extremely low vibration and superior starting reliability, especially on harsh processes.
- In tests superior liquid and powder handling has demonstrated that a five litre water slug and one kilogram fine powder slug handling capability.

Built in control panel

- All pumps are fitted with a built-in control panel for direct local control of the pump.
- Full start / stop control with indication of running mode and state of the pump with a connector for an optional Pump Display Terminal (PDT) for improved diagnostic and configuration capability.

Advanced shaft sealing technology

- Non-contacting long-life seals with integral oil blocking labyrinth seal provides for highly effective sealing.
- Combined with a four litre per minute seal purge the gearbox is protected from contamination and the vacuum space is kept free of oil.

World leading motor and drive technology

- Extremely high efficiency motors with electronic drives deliver maximum torque performance for difficult processes.
- Hermetically sealed motor eliminates oil leaks and improves pump reliability.
- Water-cooled motors and drives provide for improved reliability and long life to reduce service costs.

Advanced pumping mechanism design

- Enhanced screw-type rotor design results in smooth, gradual compression along the length of the rotor for improved thermal control and optimised pumping at all inlet pressures.
- Integrated heat management and unique rotor and stator design features provide argon gas pumping capability at full concentration.
- Advanced machining techniques and design features eliminate the need for rotor coatings while maintaining superb ultimate vacuum performance.
- Improved manufacturing technology and design contributes to low vibration and extremely quiet running of <64 dB(A) without a silencer.

Accessories for enhanced reliability

- High-flow inlet purge accessory available to aid powder removal from the pump mechanism.
- Solvent flush accessory for in-situ cleaning and removal of sticky substances from the pump mechanism.
- Solvent injection accessory for use during vacuum processing.
- All accessories controllable via the pump's advanced control system with optional hand-held Pump Display Terminal (PDT).

GXS Systemisation

The range of GXS Industrial screw pumps may be further enhanced through the addition of accessories which have been specially designed to give optimum performance in a wide range of industrial applications.

For detailed advice and availability, please consult one of our Edwards sales engineers.

Inlet and Exhaust accessories (ISO-ANSI and NW-ANSI)

- Foreline spool adaptor
- Inlet isolation valve (with position indicator)
- Inlet spool
- Inlet filter
- Inlet cyclone
- Inlet knock-out pot
- Exhaust knock-out pot
- Cleanable, drainable silencer
- Exhaust check valve

Control and monitoring accessories

- Operator panel with IP54 enclosure
- MCM microTIM (I/O control module)
- Profibus DP control module
- Cooling water flow sensor
- Purge gas flow switch
- Instrument pack (PT100 & ASG + cables)

Special accessories

- IP54 enclosure
- Solvent injection
- Heated/insulated exhaust
- Air blast cooler

GXS160/1750 Dry Pump



Edwards, a pioneer in dry pumping technology, has more than 90 years experience in harsh process vacuum applications, including dust and process contaminants handling, with more than 150,000 pumps installed worldwide.

The GXS industrial dry screw pump incorporates innovative, patented design features that establish a new standard in dry pumping.

Features & Benefits

- Designed for high reliability
- Adaptable to a wide range of applications
- Long service interval and easy swap out
- Low cost of ownership
- Minimum workplace and environmental impact

Dimensions

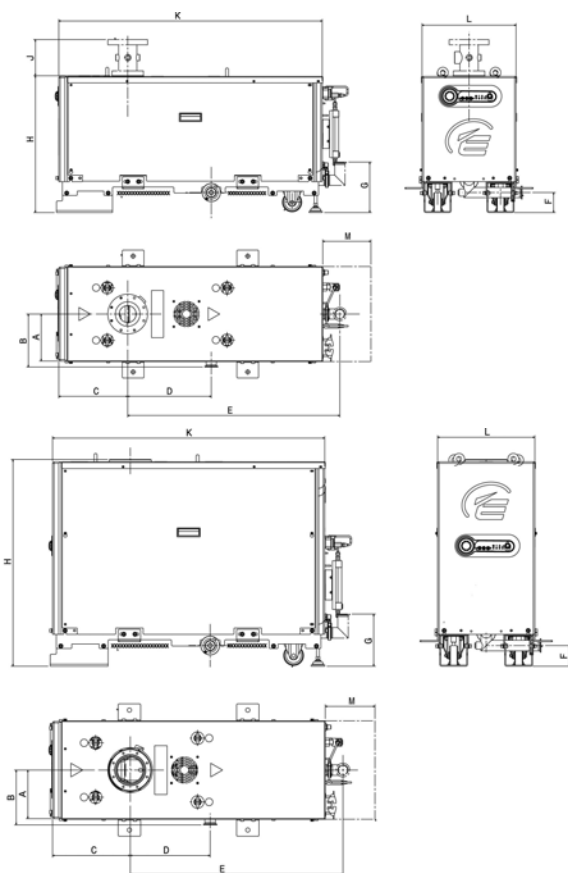

(mm)	A	B	C	D	E	F	G	H	J	K	L	M
160	195	220	285.9	346.5	879.5	83	209.4	568	150	1092	390	250
160/1750	195	220	311.6	346.5	853.8	83	209.4	829.5	-	1092	390	250

(inches)	A	B	C	D	E	F	G	H	J	K	L	M
160	7.7	8.7	11.3	13.6	34.6	3.3	8.2	22.4	5.9	43	15.4	9.8
160/1750	7.7	8.7	12.3	13.6	33.6	3.3	8.2	32.7	-	43	15.4	9.8

Applications

- Solar
- Silicon crystal growing
- Lithium Ion battery manufacture
- Freeze drying
- Pharmaceutical

Performance Curves

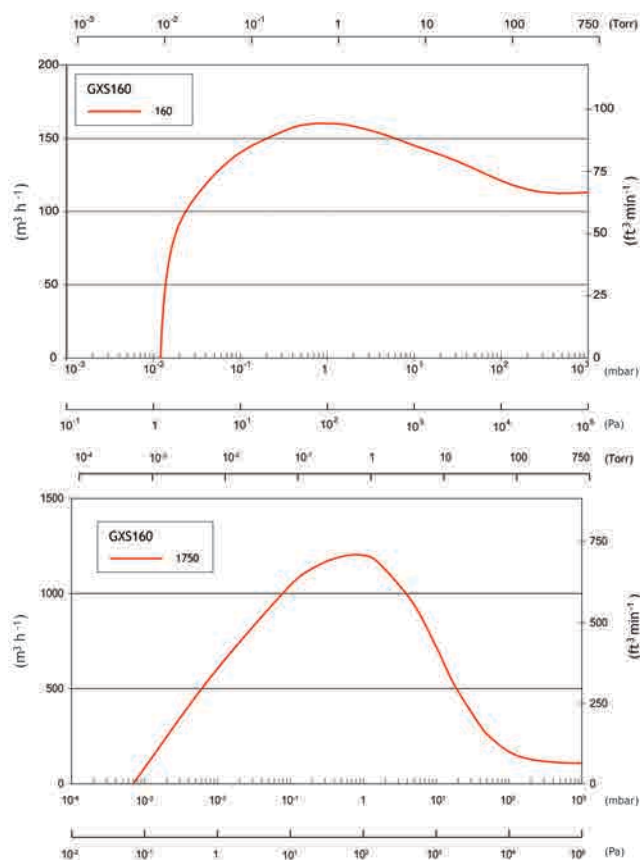

Technical Data

	GXS160	GXS160/1750
Peak Pumping Speed	160 m ³ h ⁻¹ (95 cfm)	1200 m ³ h ⁻¹ (706 cfm)
Ultimate Pressure with Purge	1.2 x 10 ⁻² mbar (9 x 10 ⁻³ Torr)	7 x 10 ⁻⁴ mbar (5.3 x 10 ⁻⁴ Torr)
Ultimate Pressure without Purge	7 x 10 ⁻³ mbar (5.3 x 10 ⁻³ Torr)	7 x 10 ⁻⁴ mbar (5.3 x 10 ⁻⁴ Torr)
Full Load Power @ ultimate pressure	3.8 kW (5.1 hp)	5.1 kW (6.8 hp)
@ peak pumping load	5 kW (6.7 hp)	7.4 kW (9.9 hp)
Inlet connection		
Light/med duty	ISO63	ISO100
Med duty +	ISO100	ISO100
Exhaust connection	NW40	NW40
Cooling Water		
Flow	4 lmin ⁻¹ (1.1 galmin ⁻¹)	7 lmin ⁻¹ (1.9 galmin ⁻¹)
Supply pressure (max)	6.9 bar (100 psig)	6.9 bar (100 psig)
DP across pump (min)	1 bar (14.7 psig)	1 bar (14.7 psig)
Temperature	5-40 °C (41-104 °F)	5-40 °C (41-104 °F)
Mass	305 Kg (672 lb)	475 Kg (1047 lb)
Volume	0.7 l (0.2 gal)	1.4 l (0.4 gal)
Purge Gas*		
Pressure		2.5-6.9 bar (36-100 psig)
Light Duty		12 slm
Medium Duty		18-52 slm
High flow purge/solvent flush supply pressure		2.5-6.9 bar (36-100 psig)
Noise		<64 dB(A)
Operating Temperature		5-40 °C (41-104 °F)
Exhaust Back Pressure (Max)		1400 mbar (20 psia)
System IP rating		31
Lubrication		PFPE Drynert® 25/6
Monitoring & Control		
Standard		Front panel - Dashboard Serial - RS232 Ethernet Webserver
Option		Parallel I/O - MicroTim Profibus DP Pump Display Terminal (PDT) FabWorks®

*Purge Gas information

Light duty - shaft seal purge and high vac purge only
 Medium duty - Shaft seal purge, inlet purge, variable gas ballast & exhaust purge (with exhaust pressure sensor)
 Medium duty + - As Medium duty, plus High Flow Purge / Solvent Flush

Ordering Information

Applications
Industrial

Pump Mechanism
Screw

Pumps / Boosters
2 160 (7.5 kW)
5 160 (7.5 kW) / 1750 (5.5 kW)

Lubrication
PFPE (Drynert 25/6)

G
S

0

0
0
0
0

Electrical
Low volt 200-230 V 3Ø 50/60 Hz 2
High volt 380-460 V 3Ø 50/60 Hz 5

Cooling
TMS Standard 0

Pump purges
Light duty (SSP + HVP) 0
Medium duty (SSP + HVP + Inlet + GB + Exh PM) 3
Medium duty + High Flow Purge / Solvent Flush 4

Installation
Side Exhaust and Skids 0
Rear Exhaust and Casters 5

SSP = Shaft seal purge, HVP = High vac purge, Inlet = Inlet purge,
 GB = Gas ballast, Exh PM = Exhaust pressure monitor and purge
 All pump variants configured for Medium Duty + High Flow Purge / Solvent Flush (MD+) require optional PDT for operation

Recommended Accessory
 Pump Display Terminal (PDT)* D37280700

Optional Accessories

GXS Auxilliary gauge cable (0-10 V)	D37241017
GXS Pressure input cable (4-20 mA)	D37241019
MCM MicroTIM	D37360320
Connector kit for MCM MicroTIM**	D37422802
Profibus® Module	D39753000
Cooling water flow monitoring switch	A50783000
Purge gas flow switch options	
160 LD/MD/MD+, 250 LD/MD/MD+, 450 LD, 750 LD	A50633000
450 MD/MD+, 750 MD/MD+	A50634000
Drynert 25/6 fluid 1 kg (528 ml)	H11312021
Drynert 25/6 fluid 5 kg (2646 ml)	H11312025

* Access to full functionality for MD & MD+ pumps requires a PDT
 ** Required to build interface cable

GXS250/2600 Dry Pump



Edwards, a pioneer in dry pumping technology, launches a new generation of dry pumps for industrial applications.

Edwards has over 90 years of experience in harsh process vacuum applications, including dust and process contaminants handling, with more than 150,000 dry pumps installed worldwide.

The GXS industrial dry screw pump incorporates innovative, patented design features that establish a new standard in dry pumping.

Features & Benefits

- Designed for high reliability
- Adaptable to a wide range of applications
- Long service interval and easy swap out
- Low cost of ownership
- Minimum workplace and environmental impact

Dimensions

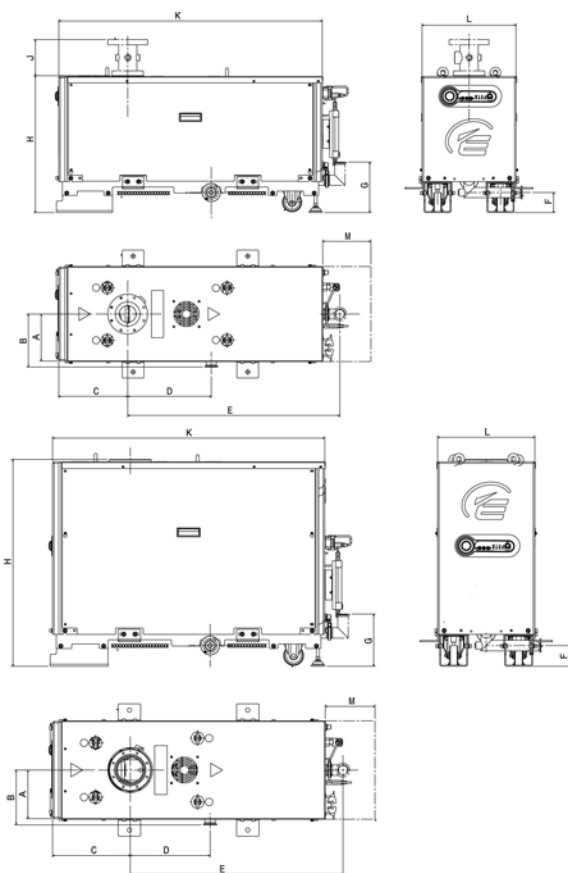

(mm)	A	B	C	D	E	F	G	H	J	K	L	M
250	195	220	285.9	346.5	879.5	83	209.4	568	150	1092	390	250
250/2600	195	220	311.6	346.5	853.8	83	209.4	829.5	-	1092	390	250

(inches)	A	B	C	D	E	F	G	H	J	K	L	M
250	7.7	8.7	11.3	13.6	34.6	3.3	8.2	22.4	5.9	43	15.4	9.8
250/2600	7.7	8.7	12.3	13.6	33.6	3.3	8.2	32.7	-	43	15.4	9.8

Applications

- Solar
- Touch display manufacture
- Lamination
- Freeze drying
- Lithium Ion battery manufacture

Performance Curves

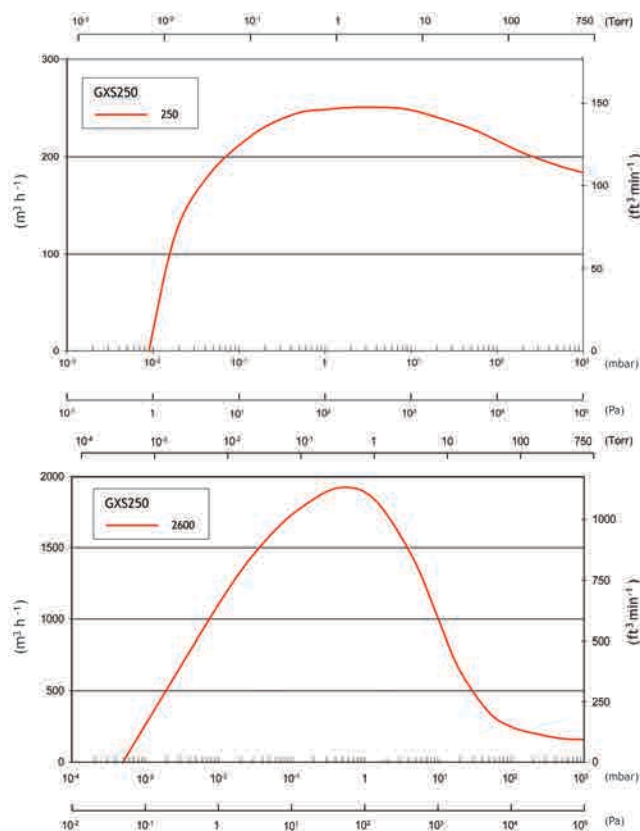

Technical Data

	GXS250	GXS250/2600
Peak Pumping Speed	250 m ³ h ⁻¹ (148 cfm)	1900 m ³ h ⁻¹ (1118 cfm)
Ultimate Pressure with purge	9 x 10 ⁻³ mbar (6.8 x 10 ⁻³ Torr)	5 x 10 ⁻⁴ mbar (3.8 x 10 ⁻⁴ Torr)
Ultimate Pressure without purge	4 x 10 ⁻³ mbar (3 x 10 ⁻³ Torr)	5 x 10 ⁻⁴ mbar (3.8 x 10 ⁻⁴ Torr)
Full Load Power @ ultimate pressure	4 kW (5.4 hp)	5.3 kW (7.1 hp)
@ peak pumping load	9 kW (12.1 hp)	9.7 kW (13 hp)
Inlet connection		
Light/med duty	ISO63	ISO160
Med duty +	ISO100	ISO160
Exhaust connection	NW40	NW40
Cooling Water		
Flow	4 lmin ⁻¹ (1.1 galmin ⁻¹)	7 lmin ⁻¹ (1.9 galmin ⁻¹)
Supply pressure (max)	6.9 bar (100 psig)	6.9 bar (100 psig)
DP across pump (min)	1 bar (14.7 psig)	1 bar (14.7 psig)
Temperature	5-40 °C (41-104 °F)	5-40 °C (41-104 °F)
Mass	305 Kg (672 lbs)	515 Kg (1035 lbs)
Volume	0.7 l (0.2 gal)	1.4 l (0.4 gal)
Purge Gas*		
Pressure		2.5-6.9 bar (36-100 psig)
Light Duty		12 slm
Medium Duty		18-52 slm
High flow purge/solvent flush supply pressure		2.5-6.9 bar (36-100 psig)
Noise		<64 dB(A)
Operating Temperature		5-40 °C (41-104 °F)
Exhaust Back Pressure (Max)		1400 mbar (20 psia)
System IP rating		31
Lubrication		PFPE Drynert [®] 25/6
Monitoring & Control		
Standard		Front panel - Dashboard Serial - RS232 Ethernet Webserver
Option		Parallel I/O - MicroTim Profibus DP Pump Display Terminal (PDT) FabWorks [®]

*Purge Gas information

Light duty - shaft seal purge and high vac purge only
 Medium duty - Shaft seal purge, inlet purge, variable gas ballast & exhaust purge (with exhaust pressure sensor)
 Medium duty + - As Medium duty, plus High Flow Purge / Solvent Flush

Ordering Information

Applications
Industrial

Pump Mechanism
Screw

Pumps / Boosters
7 250 (7.5 kW)
A 250 (7.5 kW) / 2600 (5.5 kW)

Lubrication
PFPE (Drynert 25/6)

↓ ↓ ↓ ↓

G S 0 0 0 0 0

Electrical
Low volt 200-230 V 3Ø 50/60 Hz 2
High volt 380-460 V 3Ø 50/60 Hz 5

Cooling
TMS Standard 0

Pump purges
Light duty (SSP +HVP) 0
Medium duty (SSP + HVP + Inlet + GB + Exh PM) 3
Medium duty + High Flow Purge / Solvent Flush 4

Installation
Side Exhaust and Skids 0
Rear Exhaust and Casters 5

SSP = Shaft seal purge, HVP = High vac purge, Inlet = Inlet purge, GB = Gas ballast, Exh PM = Exhaust pressure monitor and purge
 All pump variants configured for Medium Duty + High Flow Purge / Solvent Flush (MD+) require optional PDT for operation

Recommended Accessory
Pump Display Terminal (PDT)* D37280700

Optional Accessories

GXS Auxilliary gauge cable (0-10 V)	D37241017
GXS Pressure input cable (4-20 mA)	D37241019
MCM MicroTIM	D37360320
Connector kit for MCM MicroTIM**	D37422802
Profibus [®] Module	D39753000
Cooling water flow monitoring switch	A50783000
Purge gas flow switch options	
160 LD/MD/MD+, 250 LD/MD/MD+, 450 LD, 750 LD	A50633000
450 MD/MD+, 750 MD/MD+	A50634000
Drynert 25/6 fluid 1 kg (528 ml)	H11312021
Drynert 25/6 fluid 5 kg (2646 ml)	H11312025

* Access to full functionality for MD & MD+ pumps requires a PDT
 ** Required to build interface cable

GXS450/2600/4200 Dry Pump

Edwards, a pioneer in dry pumping technology, has more than 90 years experience in harsh process vacuum applications, including dust and process contaminants handling, with more than 150,000 pumps installed worldwide.



The GXS industrial dry screw pump incorporates innovative, patented design features that establish a new standard in dry pumping.

Features & Benefits

- Designed for high reliability
- Adaptable to a wide range of applications
- Long service interval and easy swap-out
- Low cost of ownership
- Minimum workplace and environmental impact

Dimensions

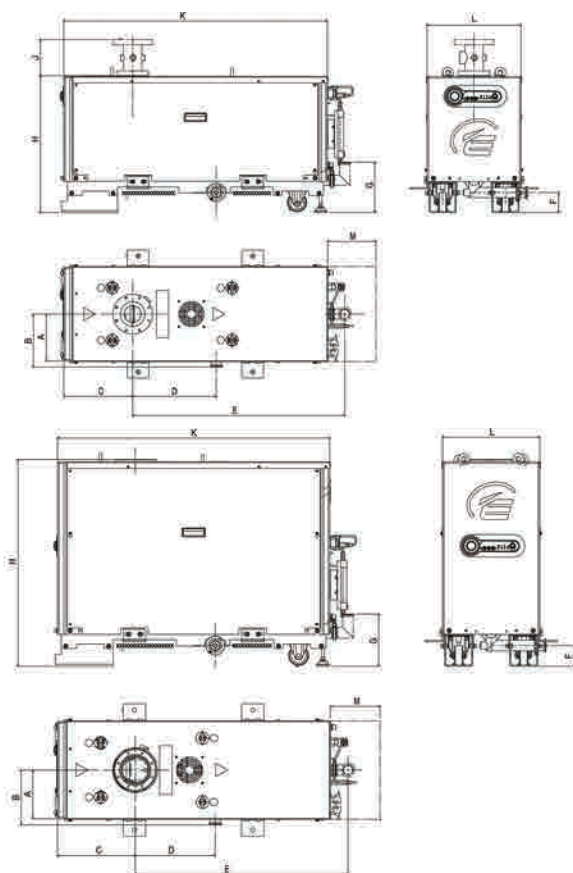

(mm)	A	B	C	D	E	F	G	H	J	K	L	M
450	258.5	283.5	394	300	871.6	83	261.4	717	150	1186	517	250
450/2600	258.5	283.5	362	332	903.8	83	261.4	1031	-	1186	517	250
450/4200	258.5	283.5	362	332	903.8	83	261.4	1031	-	1186	517	250

(inches)	A	B	C	D	E	F	G	H	J	K	L	M
450	10.2	11.2	15.5	11.8	34.3	3.3	10.3	28.2	5.9	46.7	20.4	9.8
450/2600	10.2	11.2	14.2	13.1	33.6	3.3	10.3	40.6	-	46.7	20.4	9.8
450/4200	10.2	11.2	14.2	13.1	33.6	3.3	10.3	40.6	-	46.7	20.4	9.8

Applications

- Solar
- Freeze drying
- Sterilisation
- Coating
- Metallurgy

Performance Curves

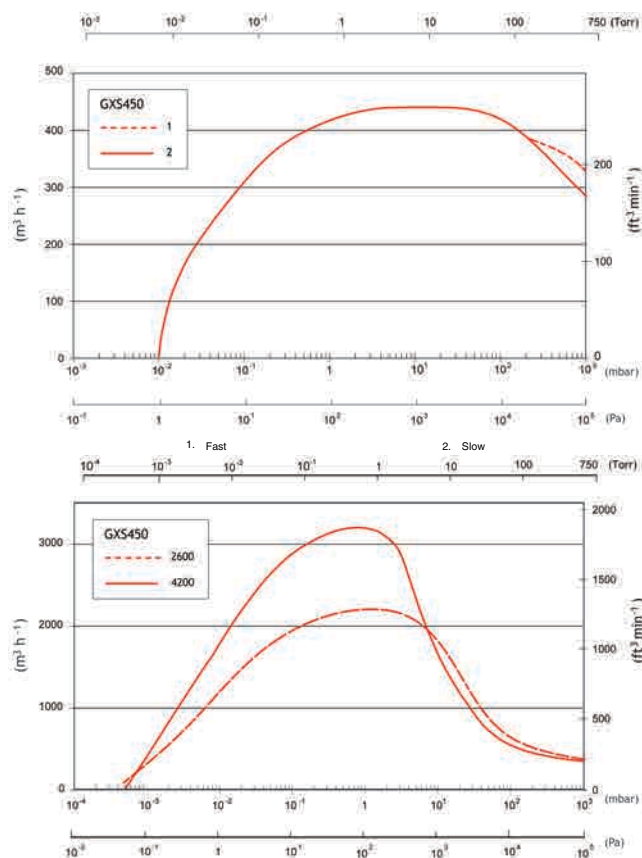

Technical Data

	GXS450	GXS450/2600	GXS450/4200
Peak Pumping Speed	450 m ³ h ⁻¹ (265 cfm)	2200 m ³ h ⁻¹ (1295 cfm)	3026 m ³ h ⁻¹ (1781 cfm)
Ultimate Pressure with purge	1 x 10 ⁻² mbar (7.5 x 10 ⁻³ Torr)	5.4 x 10 ⁻⁴ mbar (3.8 x 10 ⁻⁴ Torr)	5.4 x 10 ⁻⁴ mbar (3.8 x 10 ⁻⁴ Torr)
Ultimate Pressure without purge	5 x 10 ⁻³ mbar (3.8 x 10 ⁻³ Torr)	5 x 10 ⁻⁴ mbar (3.8 x 10 ⁻⁴ Torr)	5 x 10 ⁻⁴ mbar (3.8 x 10 ⁻⁴ Torr)
Full Load Power @ ultimate pressure	7.2 kW (9.6 hp)	8.8 kW (11.8 hp)	9.4 kW (12.6 hp)
@ peak pumping load	17.3 kW (23.2 hp)	20 kW (26.8 hp)	21.1 kW (28.3 hp)
Cooling water flow @ min DP	6 lmin ⁻¹ (1.6 galmin ⁻¹)	12 lmin ⁻¹ (3.2 galmin ⁻¹)	12 lmin ⁻¹ (3.2 galmin ⁻¹)
Cooling water DP across pump	1 barg (15 psig)	1.5 barg (22 psig)	1.5 barg (22 psig)
Inlet connection	ISO100	ISO160	ISO160
Exhaust connection	NW50	NW50	NW50
Mass	640 Kg (1411 lbs)	860 Kg (1996 lbs)	868 Kg (1914 lbs)
Lubrication volume	1.8 l (0.5 gal)	2.5 l (0.7 gal)	3.6 l (1.0 gal)
Cooling Water supply pressure (max)		6.9 bar (100 psig)	
Cooling Water temperature		5-40 °C (41-104 °F)	
Purge gas - pressure*		2.5-6.9 bar (36-100 psig)	
Purge gas - light duty*		12 slm	
Purge gas - medium duty*		18-146 slm	
High flow purge/solvent flush supply pressure		2.5-6.9 bar (36-100 psig)	
Noise		<64 dB(A)	
Operating Temperature		5-40 °C (41-104 °F)	
Exhaust back pressure (max)		1400 mbar (20 psia)	
IP rating		31	
Lubrication		PFPE Drynert [®] 25/6	
Monitoring & Control Standard		Front panel - Dashboard Serial - RS232 Ethernet Webserver	
Option		Parallel - MCM MicroTim Profibus DP Pump Display Terminal (PDT) FabWorks [®]	

* Purge Gas information
 Light duty - shaft seal purge and high vac purge only
 Medium duty - Shaft seal purge, inlet purge, variable gas ballast & exhaust purge (with exhaust pressure sensor)
 Medium duty + - As Medium duty, plus High Flow Purge / Solvent Flush

Ordering Information

Applications
Industrial

Pump Mechanism
Screw

Pumps / Boosters
 D 450 (11 kW)
 F 450 (11 kW) / 2600 (7.5 kW)
 G 450 (11 kW) / 4200 (7.5 kW)

Lubrication
PFPE (Drynert 25/6)

Electrical
 Low volt 200-230 V 3Ø 50/60 Hz 2
 High volt 380-460 V 3Ø 50/60 Hz 5

Cooling
TMS Standard 0

Pump purges
 Light duty (SSP +HVP) 0
 Medium duty (SSP + HVP + Inlet + GB + Exh PM) 3
 Medium duty + High Flow Purge / Solvent Flush 4

Installation
 Side Exhaust and Skids 0
 Rear Exhaust and Casters 5

Ordering Code: G S [] [] 0 [] [] 0 0 0 0

SSP = Shaft seal purge, HVP = High vac purge, Inlet = Inlet purge, GB = Gas ballast, Exh PM = Exhaust pressure monitor and purge
 Medium Duty (MD) variants require optional PDT for operation
 All pump variants configured for Medium Duty + High Flow Purge / Solvent Flush (MD+) require optional PDT for operation

Recommended Accessory
 Pump Display Terminal (PDT)* D37280700

Optional Accessories

GXS Auxilliary gauge cable (0-10 V)	D37241017
GXS Pressure input cable (4-20 mA)	D37241019
MCM MicroTIM	D37360320
Connector kit for MCM MicroTIM**	D37422802
Profibus [®] Module	D39753000
Cooling water flow monitoring switch	A50783000
Purge gas flow switch options	
160 LD/MD/MD+, 250 LD/MD/MD+, 450 LD, 750 LD	A50633000
450 MD/MD+, 750 MD/MD+	A50634000
Drynert 25/6 fluid 1 kg (528 ml)	H11312021
Drynert 25/6 fluid 5 kg (2646 ml)	H11312025

* Access to full functionality for MD & MD+ pumps requires a PDT
 ** Required to build interface cable

GXS750/2600/4200 Dry Pump

Edwards, a pioneer in dry pumping technology, has more than 90 years experience in harsh process vacuum applications, including dust and process contaminants handling, with more than 150,000 pumps installed worldwide.



The GXS industrial dry screw pump incorporates innovative, patented design features that establish a new standard in dry pumping.

Features & Benefits

- Designed for high reliability
- Adaptable to a wide range of applications
- Long service interval and easy swap-out
- Low cost of ownership
- Minimum workplace and environmental impact

Dimensions

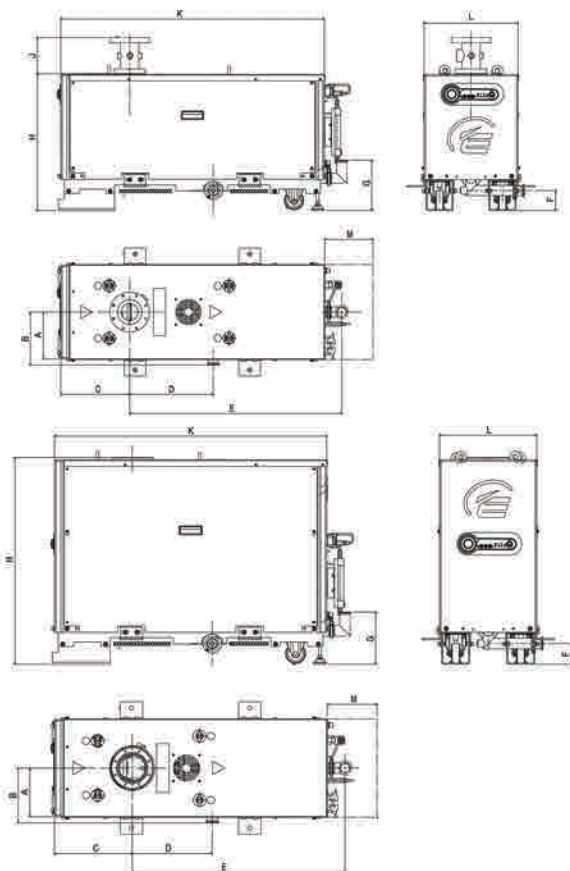

(mm)	A	B	C	D	E	F	G	H	J	K	L	M
750	258.5	283.5	576	413	1134	83	261.4	717	150	1622	517	250
750/2600	258.5	283.5	657	332	1053	83	261.4	1031	-	1622	517	250
750/4200	258.5	283.5	657	332	1053	83	261.4	1031	-	1622	517	250

(inches)	A	B	C	D	E	F	G	H	J	K	L	M
750	10.2	11.2	15.5	11.8	34.3	3.8	10.3	28.2	5.9	46.7	20.4	9.8
750/2600	10.2	11.2	25.9	13.1	41.5	3.8	10.3	40.6	-	63.9	20.4	9.8
750/4200	10.2	11.2	25.9	13.1	41.5	3.8	10.3	40.6	-	63.9	20.4	9.8

Applications

- Solar
- Freeze drying
- Sterilisation
- Coating
- Metallurgy

Performance Curves

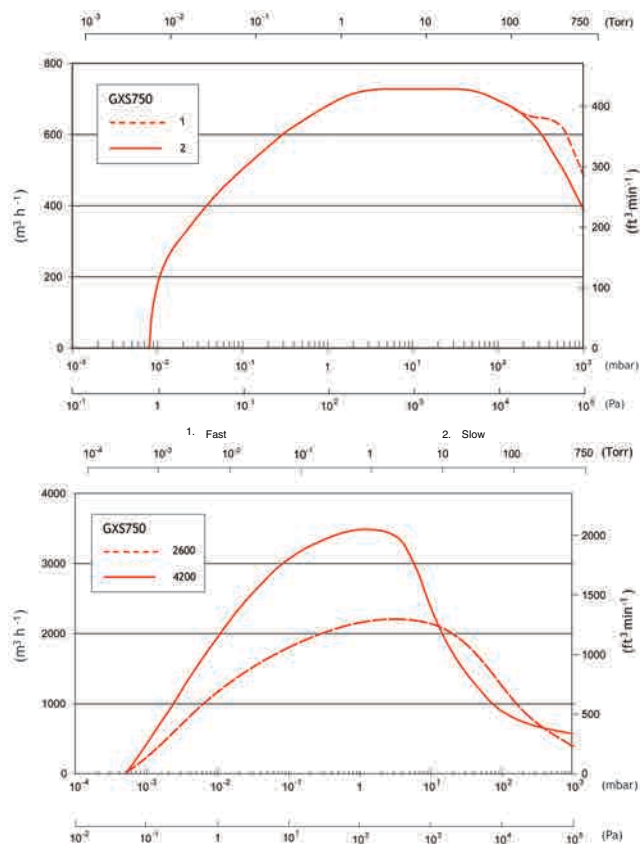

Technical Data

	GXS750	GXS750/2600	GXS750/4200
Peak Pumping Speed	740 m ³ h ⁻¹ (436 cfm)	2300 m ³ h ⁻¹ (1354 cfm)	3450 m ³ h ⁻¹ (2031 cfm)
Ultimate Pressure with purge	8 x 10 ⁻³ mbar (6 x 10 ⁻³ Torr)	5 x 10 ⁻⁴ mbar (3.8 x 10 ⁻⁴ Torr)	5 x 10 ⁻⁴ mbar (3.8 x 10 ⁻⁴ Torr)
Ultimate Pressure without purge	3 x 10 ⁻³ mbar (2.3 x 10 ⁻³ Torr)	5 x 10 ⁻⁴ mbar (3.8 x 10 ⁻⁴ Torr)	5 x 10 ⁻⁴ mbar (3.8 x 10 ⁻⁴ Torr)
Full Load Power @ ultimate pressure	10 kW (13.4 hp)	11.1 kW (14.9 hp)	11.5 kW (15.4 hp)
@ peak pumping load	37 kW (49.6 hp)	40 kW (53.6 hp)	40 kW (53.6 hp)
Cooling Water flow @ min DP	10 lmin ⁻¹ (2.6 galmin ⁻¹)	12 lmin ⁻¹ (3.2 galmin ⁻¹)	12 lmin ⁻¹ (3.2 galmin ⁻¹)
Cooling Water DP across pump	2 bar (29 psig)	2.5 bar (36 psig)	2.5 bar (36 psig)
Inlet connection	ISO100	ISO160	ISO160
Exhaust connection	NW50	NW50	NW50
Mass	640 Kg (1411 lb)	908 Kg (2002 lb)	953 Kg (2101 lb)
Lubrication volume	2.4 l (0.6 gal)	3.1 l (0.8 gal)	4.2 l (1.1 gal)
Cooling Water supply pressure (max)		6.9 bar (100 psig)	
Cooling Water temperature			
High volts		5-40 °C (41-104 °F)	
Low Volts		5-30 °C (41-86 °F)	
Purge gas - pressure*		2.5-6.9 bar (36-100 psig)	
Purge gas – light duty*		12 slm	
Purge gas – medium duty*		18-146 slm	
High flow purge/solvent flush supply pressure		2.5-6.9 bar (36-100 psig)	
Noise		<70B(A)	
Operating Temperature		5-40 °C (41-104 °F)	
Exhaust back pressure (max)		1400 mbar (20 psia)	
IP rating – standard		31	
Lubrication		PFPE Dryner [®] 25/6	
Monitoring & Control			
Standard		Front panel - Dashboard	
		Serial - RS232	
		Ethernet Webserver	
Option		Parallel – MCM MicroTim	
		Profibus DP	
		Pump Display Terminal (PDT)	
		FabWorks [®]	

* Purge Gas information

Light duty - shaft seal purge and high vac purge only
 Medium duty - Shaft seal purge, inlet purge, variable gas ballast & exhaust purge (with exhaust pressure sensor)
 Medium duty + - As Medium duty, plus High Flow Purge / Solvent Flush

Ordering Information

Applications
Industrial

Pump Mechanism
Screw

Pumps / Boosters
 L 750 (22 kW)
 N 750 (22 kW) / 2600 (7.5 kW)
 P 750 (22 kW) / 4200 (7.5 kW)

Lubrication
PFPE (Dryner 25/6)

↓ ↓ ↓ ↓

G S 0 0 0 0 0

Electrical
 Low volt 200-230 V 3Ø 50/60 Hz 2
 High volt 380-460 V 3Ø 50/60 Hz 5

Cooling
TMS Standard 0

Pump purges
 Light duty (SSP +HVP) 0
 Medium duty (SSP + HVP + Inlet + GB + Exh PM) 3
 Medium duty + High Flow Purge / Solvent Flush 4

Installation
 Side Exhaust and Skids 0
 Rear Exhaust and Casters 5

SSP = Shaft seal purge, HVP = High vac purge, Inlet = Inlet purge, GB = Gas ballast, Exh PM = Exhaust pressure monitor and purge
 Medium Duty (MD) variants require optional PDT for operation
 All pump variants configured for Medium Duty + High Flow Purge / Solvent Flush (MD+) require optional PDT for operation

Recommended Accessory

Pump Display Terminal (PDT)*	D37280700
------------------------------	-----------

Optional Accessories

GXS Auxilliary gauge cable (0-10 V)	D37241017
GXS Pressure input cable (4-20 mA)	D37241019
MCM MicroTIM	D37360320
Connector kit for MCM MicroTIM**	D37422802
Profibus [®] Module	D39753000
Cooling water flow monitoring switch	A50783000
Purge gas flow switch options	
160 LD/MD/MD+, 250 LD/MD/MD+, 450 LD, 750 LD	A50633000
450 MD/MD+, 750 MD/MD+	A50634000
Dryner 25/6 fluid 1 kg (528 ml)	H11312021
Dryner 25/6 fluid 5 kg (2646 ml)	H11312025

* Access to full functionality for MD & MD+ pumps requires a PDT
 ** Required to build interface cable

Drystar 80 Pump and Booster Package



Edwards DRYSTAR 80 dry vacuum pump is configured for ease of installation and commissioning while providing a clean, robust and cost effective alternative to traditional oil-sealed pumps.

The DRYSTAR 80 is designed to handle large volumes of condensable vapours and particulate loads to provide a consistent pumping performance, minimal service intervention and low cost of ownership. The use of dry pumping technology and unique seal design will eliminate contamination throughout the vacuum process making the DRYSTAR 80 suitable for a range of applications and environments.

Features & Benefits

- Extended periods between user intervention to achieve maximum uptime
- No exhaust filters to service offering lower consumable cost and inventory
- Available in hydrocarbon or PFPE fluid (for oxygen) versions making it suitable for a wide range of applications and environments
- Continuous pumping from atmosphere
- Consistent performance in demanding applications

Dimensions

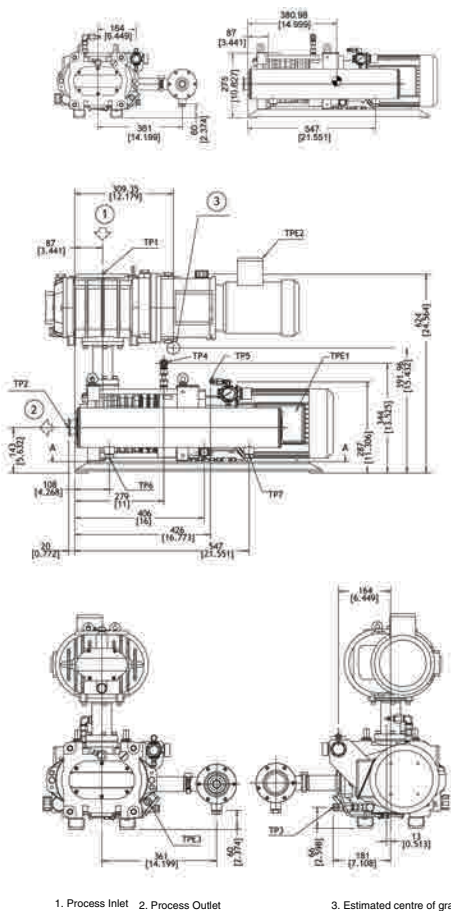

Applications

- Vacuum metallurgy processes
- Heat treatment carburisation
- Thin film coating technologies
- Pharmaceutical freeze drying
- Refrigeration and air conditioning system evacuation, drying, and backfilling

Performance Curves

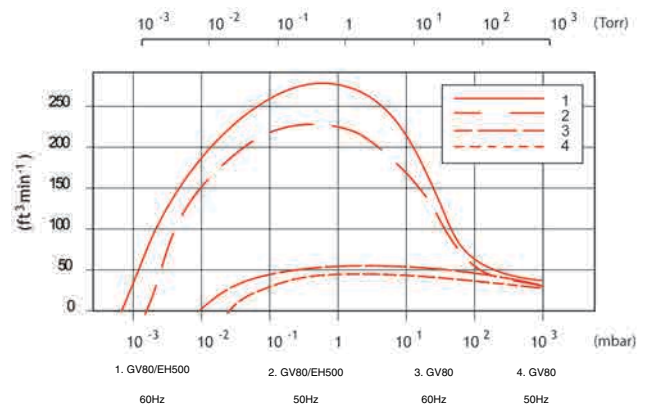

Technical Data

	Drystar 80	Drystar 80/EH500
Peak Pumping Speed		
50 Hz	80 m ³ h ⁻¹ (47 cfm)	390 m ³ h ⁻¹ (230 cfm)
60 Hz	94 m ³ h ⁻¹ (56 cfm)	471 m ³ h ⁻¹ (277 cfm)
Ultimate Pressure	<3x10 ⁻² mbar (<2x10 ⁻² Torr)	<3x10 ⁻³ mbar (<2x10 ⁻³ Torr)
Power @ ultimate pressure	3.6 kW (4.8 hp)	4.3 kW (5.6 hp)
Power @ peak pumping load	5.8 kW (7.8 hp)	6.7 kW (9.0 hp)
Electrical supply	200-230V 3Æ 50/60Hz or 380-460V 3Æ 50/60Hz	200-230V 3Æ 50/60Hz or 380-460V 3Æ 50/60Hz
Inlet connection	ISO40	ISO100
Outlet connection	NW40	NW40
Cooling method	Water	Water/Air
Cooling Water flow rate	1 lmin ⁻¹ (0.26 galmin ⁻¹)	1 lmin ⁻¹ (0.26 galmin ⁻¹)
Max cooling Water supply pressure	8 bar (116 psig)	8 bar (116 psig)
Cooling Water DP across pump	2.1 bar (30 psig)	2.1 bar (30 psig)
Cooling Water temp	5-35 °C (41-95 °F)	5-35 °C (41-95 °F)
Cooling Water inlet	½" Quick connect coupling	½" Quick connect coupling
Cooling Water outlet	½" Quick connect plug	½" Quick connect plug
Purge gas pressure	0.5 bar (6-8 psig)	0.5 bar (6-8 psig)
Purge gas light duty	15 slm	15 slm
Purge gas connection	¼" Quick connect coupling	¼" Quick connect coupling
Weight	145 kg (320 lbs)	220 kg (485 lbs)
Noise (with exhaust silencer)	<78 dB(A)	<78 dB(A)
Exhaust back pressure	1.3 bar (18 psig)	1.3 bar (18 psig)
Lubrication volume	0.4 l (0.1 gal)	1.4 l (0.4 gal)
Hydrocarbon lubrication	SHC629	SHC629 / Ultragrade 20
PFPE lubrication	YVAC 25/6	YVAC 25/6 / YVAC 16/6

Ordering Information

Product Description	Order No.
Drystar 80 SSP & Silencer 380-415V 50Hz	NR8030000
DRYSTAR 80 SSP & Silencer 230/460V 60 Hz	NR8031000
Drystar 80 SSP & Silencer 380V 60 Hz	NR8032000
Drystar 80 SSP & Silencer 200V 50 Hz	NR8033000
Drystar 80 SSP & Silencer 200V 60 Hz	NR8034000
Drystar 80 SSP (24VAC Solenoid) Silencer Wall Mount MCM 230V 60 Hz	NR2A0000
Drystar 80 SSP (24VAC Solenoid) Silencer Wall Mount MCM 460V 60 Hz	NR2A4000
Drystar 80 SSP (24VAC Solenoid) Silencer Wall Mount MCM 208V 60 Hz	NR29W000
Drystar 80F PFPE SSP (24vac Solenoid) Silencer Wall Mount MCM 208V 60 Hz	NR29Y000
Drystar 80 PFPE SSP & Silencer 380-415V 50Hz	NR8035000
Drystar 80 PFPE SSP & Silencer 230/460V 60 Hz	NR8036000
Drystar 80 PFPE SSP & Silencer 380V 60 Hz	NR8037000
Drystar 80 PFPE SSP & Silencer 200V 50 Hz	NR8038000
Drystar 80 PFPE SSP & Silencer 200V 60 Hz	NR8039000
Drystar 80F PFPE SSP (24vac Solenoid) Silencer Wall Mount MCM 230V 60 Hz	NR2A2000
Drystar 80F PFPE SSP (24vac Solenoid) Silencer Wall Mount MCM 460V 60 Hz	NR2A6000
Drystar 80/EH500 SSP & Silencer 380-415V 50Hz	NR041000
Drystar 80/EH500 SSP & Silencer 230/460V 60 Hz	NR042000
Drystar 80/EH500 SSP & Silencer 380V 60 Hz	NR043000
Drystar 80/EH500 SSP & Silencer 200V 50 Hz	NR044000
Drystar 80/EH500 SSP & Silencer 200V 60 Hz	NR045000
Drystar 80/EH500 SSP (24vac Solenoid) Silencer Wall Mount MCM 208V 60 Hz	NR29X000
Drystar 80/EH500 SSP (24vac Solenoid) Silencer Wall Mount MCM 230V 60 Hz	NR2A1000
Drystar 80/EH500 SSP (24vac Solenoid) Silencer Wall Mount MCM 460V 60 Hz	NR2A5000
Drystar 80/EH500 PFPE SSP & Silencer 380-415V 50Hz	NR046000
Drystar 80/EH500 PFPE SSP & Silencer 230/460V 60 Hz	NR047000
Drystar 80/EH500 PFPE SSP & Silencer 380V 60 Hz	NR048000
Drystar 80/EH500 PFPE SSP & Silencer 200V 50 Hz	NR049000
Drystar 80/EH500 PFPE SSP & Silencer 200V 60 Hz	NR050000
Drystar 80/EH500F PFPE SSP (24vac Solenoid) Silencer Wall Mount MCM 208V 60 Hz	NR29Z000
Drystar 80/EH500F PFPE SSP (24vac Solenoid) Silencer Wall Mount MCM 230V 60 Hz	NR2A3000
Drystar 80/EH500F PFPE SSP (24vac Solenoid) Silencer Wall Mount MCM 460V 60 Hz	NR2A7000
Accessories & Spares	Order No.
Acoustic Enclosure For GV80	A50575000
Atmospheric Shaft Seal Purge Kit	NRA640450
Exhaust Silencer	A50805020
Fomblin® 25/6 fluid	H026008001
Fomblin® 25/6 fluid	H026008003
Fomblin® 25/6 fluid	H026008005
Fomblin® 25/6 fluid	H026008006
Fomblin® 25/6 fluid	H026008007
Fomblin® 25/6 fluid	H11312019
Fomblin® Y16/6 fluid	H026001003
Fomblin® Y16/6 fluid	H026001005
Fomblin® Y16/6 fluid	H026001006
Fomblin® Y16/6 fluid	H11306019
Fomblin® Y16/6 fluid	H11306020
Gear Box Oil 4 Ltr Mobil SHC 629	H11023011
Routine Maintenance Kit GV80	A70212825
Spares Kit Con C&O EH/QMB250/500A	A30151815
Ultragrade 20 Oil	H11024010
Ultragrade 20 Oil	H11024011
Ultragrade 20 Oil	H11024012
Ultragrade 20 Oil	H11024013
Ultragrade 20 Oil	H11024015

IDX 1000/1300

The IDX1000 is the new benchmark in performance for fast pumpdown of large chambers and high capacity pumping for industrial processes.



Based on the double-ended screw technology, the IDX Dry Vacuum Pump will give you all the reliability and performance you want for your process. The IDX outperforms all other dry pumps in robustness, performance and ease of operation, giving you faster pump-down from atmosphere and managing higher throughput at low pressures. Dry pumping systems reduce energy costs, eliminate effluent and can give significant improvements in product quality, making them the ideal solution for many coating and metallurgy processes.

Features & Benefits

- Improved Performance and Reliability
- Continuous performance from atmosphere to ultimate
- Excellent thermal profile and temperature control
- Tolerates liquid and particles
- Does not contaminate your process

Dimensions

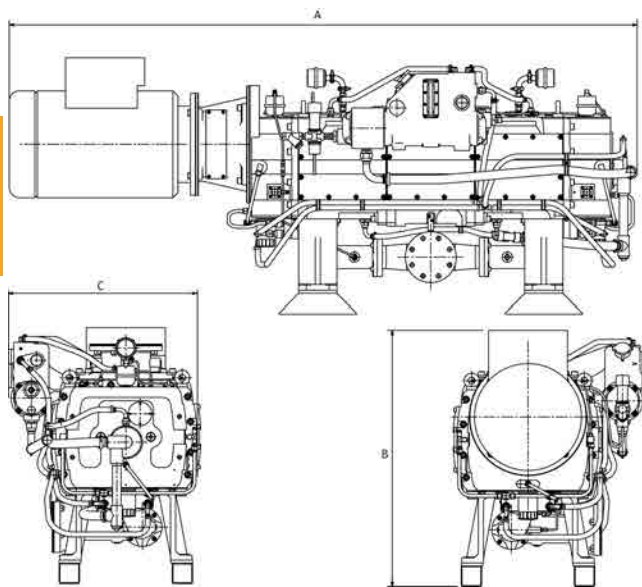

	IDX1000		IDX1300	
A	50Hz	2250mm (88.5")	2465mm (97")	
	60Hz	2290mm (90.1")	2515mm (99")	
B		854mm (33.6")	1005mm (39.6")	
C		750mm (29.5")	750mm (29.5")	

Applications

- Metallurgy
- Vacuum Induction Melting (VIM)
- Vacuum Arc Refining (VAR)
- Precision Investment Casting (PIC)
- Steel Degassing

Performance Curves

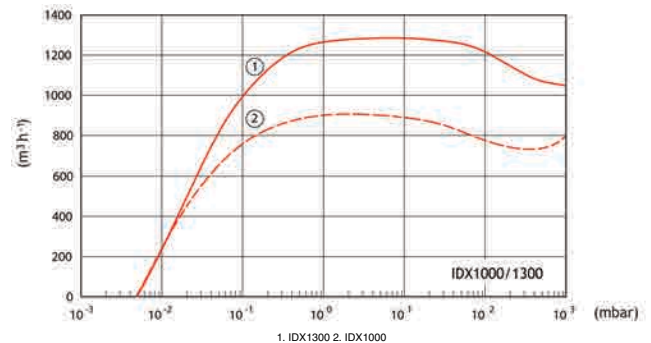

Technical Data

Mass	IDX1000	IDX1300
50 Hz	1560 kg (3439 lb)	1590 kg (3506 lb)
60 Hz	1630 kg (3594 lb)	1660 kg (3660 lb)
Pumping Speed		
Nominal	1000 m ³ h ⁻¹ (589 cfm)	1300 m ³ h ⁻¹ (766 cfm)
Actual	900 m ³ h ⁻¹ (560 cfm)	1250 m ³ h ⁻¹ (736 cfm)
Ultimate pressure	5 x 10 ⁻² mbar (3.75 x 10 ⁻² Torr)	5 x 10 ⁻² mbar (3.75 x 10 ⁻² Torr)
Noise	82 dB(A)	82 dB(A)
Motor	30 kW (40 hp)	30 kW (40 hp)
Optional	22 kW (30 hp)	

Ordering Information

Product Description	Order No.
IDX1300 30kW DIN Safe Area	A70904985
IDX1300 40hp ANSI Safe Area	A70914985
IDX1000 22 kW 50 Hz safe area	A70803985
IDX1000 30 kW 50 Hz safe area extended performance	A70804985
IDX1000 30 hp 60 Hz safe area	A70813985
IDX1000 40 hp 60 Hz safe area extended performance	A70814985
Accessories & Spares	Order No.
Gear Box Oil 4 Ltr Mobil SHC 629	H11023011
Coolant 0.9/2L Drystar	H12810003
IDX Routine maintenance kit	A70801800
IDX Heat exchanger cleaning kit	A70801801
IDX Cooling system overhaul kit	A70801802
IDX Motor fitting kit	A70801803
IDX Drive coupling kit	A70801804
IDX Bearing and seal replacement kit	A70801805
IDX Oil pump replacement kit	A70801806
IDX Strip and rebuild kit	A70801807
IDX Flame arrestor cleaning kit	A70801808
IDX Hoses kit	A70801809
IDX Flame arrestor replacement kit (inlet)	A70801810
IDX Flame arrestor replacement kit (outlet)	A70801811
IDX Flame arrestor tooling kit	A70801812

EM Oil Sealed Rotary Pumps



Edwards rugged two stage mechanical oil sealed pumps are available in sizes from 40 to 275 m³h⁻¹ / 30-206 ft³min⁻¹. They feature:

- Advanced oil lubrication circuit
- High reliability
- Accessories to match your application needs

Application and Accessory Information EM Rotary Pumps

The use of Edwards rotary pumps with our comprehensive range of accessories will result in enhanced performance and reliability. The information below will help you to select the correct accessories for your application. However, we recommend that you treat this as a guide only, because the final selection of components can be influenced by the operation of your vacuum system and the process by-products. If in doubt, please contact Edwards or your local supplier for further advice from an Edwards application specialist.

When you select accessories for your system, the major aim is to prolong the life and the safe operation of the pumps and to ensure that the system continues to perform at its ultimate specification. To do this, you need to ensure that the system is able to accommodate the process media and any process by-products, including vapours, liquids or particulates, which may damage the pumps. At the same time, you should ensure that any materials discharged from the system to atmosphere are not harmful to the environment and to people nearby.

Broad Application Coverage

Industrial

Industrial EM primary pumps are annotated with the suffix "IND". EM primary pumps are safe to handle non-flammable gases and vapours within the normal operating parameters of the pump. Flammable gases and vapours may also be pumped, provided they are outside the flammable range, please consult Edwards for advice.

PFPE

EM primary pumps may be supplied for use with PFPE oil. This enables them to be used in harsh (corrosive) processes, or where the presence of Oxygen will result in rapid degradation of hydrocarbon oils.

ATEX

- EM primary pumps (hydrocarbon oil only) may be supplied with ATEX classification either as part of a pump system or stand-alone. Please consult Edwards.
- ATEX compliance is typically specified for use in Europe, but may also be required in other areas.

ATEX compliant EM primary pumps are suitable for operation in ATEX systems rated as follows:

Pump Classification	Internal Classification	External Classification
E2M40 & E2M80	⊕ II 3 Gc IIB T4	⊕ II 2 G IIB T4
E2M175 & E2M275	⊕ II 3 Gc IIB T3	⊕ II 2 G IIB T160

Where the following classification...

Symbol	Meaning
⊕	Specifies that an ATEX-compliant EM pump can be used in a potentially explosive atmosphere
II	Equipment Group – II = non-mining equipment
3 (Int) 2 (Ext) G	Equipment Category 3 (or 2) – G = Gas
c	Constructional safety
IIB	Gas Group – Suitable to pump gases in gas group IIB Where no gas group is mentioned, there are no limitations
T4 T160 T3	Temperature Class – Gas auto-ignition temperature greater than: – T4 = 135 °C, T160 = 160 °C, T3 = 200 °C

A four-pole, three-phase ATEX approved flameproof motor provides direct drive through an ATEX certified flexible coupling to the E2M40, E2M80, E2M175 and E2M275 pumps. A cooling fan is attached to the drive coupling on the E2M40 and E2M80 pumps. The E2M175 and E2M275 pumps are water-cooled.

Lubrication is provided by a sliding vane oil pump, which delivers pressurized oil to the vacuum pumping mechanism.

Pumps are supplied with sealed Gas Ballast. Plugs have been fitted to prevent flammable atmospheres accidentally entering the pump. If the gas ballast facility is required, an N₂ purge must be used, or clean air supplied from a safe area.

For much of the operating cycle the pump operates at pressures significantly below 0.8 bar (11.6 psi) absolute. However, the final stage of the pump will exhaust to atmosphere and there is a startup and shutdown period where the whole pump is briefly operating at atmospheric pressure.

A surface temperature thermal snap switch is fitted to the body of the E2M175 and E2M275 rotary pumps. This must be connected to an intrinsically safe circuit suitable for the hazardous zone in which it may be located; otherwise it must be located in a safe area. If the pump temperature should rise due to a fault condition, the snap switch activates and the pump will shut-off.

Trapping Particulates

In any application, first ensure that particulates in the process stream are trapped before they get into the pump: use the ITM or ITF inlet filters which are suitable for use with oil-sealed and dry pumps. However, in processes which generate or contain large amounts of particulates, some will enter the pump: use our EOF an external oil filter to remove particulates from the pump oil during operation.

ITF inlet dust filters If the mechanical pump is a backing pump for a diffusion pump, the diffusion pump will trap particulates during normal operation, but the diffusion pump will not trap dust during the roughing stage of the process cycle. We recommend you fit an ITF filter to the mechanical pump inlet (that is, in the foreline): this filter has a replaceable element. Note that the impedance of a clean filter will cause the pumping speed to decrease by about 10% at 1 mbar and 20% at 10⁻² mbar. The ITF filter is more than 96% efficient, when tested in accordance with BS2831.

ITM High Capacity Inlet Dust Filters Use an ITM filter for applications where there is a high load of dust and particulates. Fit the ITM directly to the inlet of a rotary or mechanical booster pump. This filter has a stainless steel mesh element that can be washed and re-used. It is ideal for use when backing diffusion pumps or for wet processes where a paper filter may become blocked quickly. The ITM filter has high conductance and is therefore ideal for applications which require fast pump down times. The ITM filter has an efficiency of 90%, when tested in accordance with BS3831.

EOF External Oil Filters Use the EOF's with the EM oil-sealed rotary pumps, to remove particulates trapped in the pump oil.

The EOFA and EOFM filters use the internal pressurized oil system of the pump to continually filter a proportion of the pump oil. These filters are only suitable for hydrocarbon oil. The EOFM filter removes particulates down to 0.5 microns, and the EOFA filter both removes particulates and includes an active element to remove acidic and other aggressive contaminants from the oil.

Pumping Vapours

The use of gas ballast significantly improves vapour handling capability of oil sealed rotary pumps. We offer a number of accessories to improve the utility of gas ballast.

EBV Gas Ballast Control Valve Fit EBV gas ballast control valve to allow remote or automated control of gas ballast.

TCV Temperature Control Valve The vapour pumping performance of the larger oil sealed pumps can be enhanced by fitting a TCV. Use the TCV both to warm-up the pump faster (which reduces the amount of condensation in the pump) and to reduce water usage and cost.

ITC Inlet Chemical Traps Fit an ITC trap to the inlet of the pump to protect against the aggressive process vapours that may corrode the pump or degrade the oil.

Trapping Liquids

The use of gas ballast allows an oil sealed pump to process significant quantities of vapour. However, oil sealed pumps can not pump liquid streams and it is important both to remove liquids before they reach the pump inlet and to prevent condensed liquids from flowing back into the pump outlet. The following accessories may be suitable for your application:

ITO Inlet Trap The ITO inlet trap is ideal for processes where there is a risk of liquids in the process entering the pump inlet. Fit the ITO trap to the pump inlet or elsewhere in the foreline.

CP Catchpot Process vapours passing through the pump may condense after the pump outlet, in the exhaust line. Fit a CP catchpot to the pump outlet to trap the condensates and prevent them flowing back into the pump.

Exhaust Management

You should aim to minimise the impact of gases and vapours which exhaust from the pump outlet. Edwards offers a range of exhaust management systems for the most exacting applications. However, for most straight-forward applications of oil sealed rotary pumps, we recommend that you fit an oil mist filter to the pump outlet to remove oil mist vapour. A mist filter is not required if you vent the exhaust gases remotely or pass them through exhaust scrubbing equipment.

MF Oil Mist Filters The MF filters remove oil mist (vapour) from the process gases exhausted from the outlet of an oil sealed pump. The filters remove both odour and oil vapour and so prevent it from reaching the atmosphere and the workplace.

Back Migration

When operated at ultimate pressure for extended periods of time, any oil sealed pump allows oil vapour to back migrate into the process chamber. The back-migration of oil vapour could contaminate your process or your vacuum system.

ITC Inlet Chemical Trap Fit an ITC inlet chemical trap (filled with an alumina charge) to the pump inlet to trap oil vapour and to prevent back migration.

Applications

- Refrigeration dehydration
- Brake line evacuation
- TV aluminisers
- Vacuum metallurgy
- Fluorescent light tube pumping
- Thin film coating
- IT hard disc coating
- Vacuum distillation
- Cryogenic vessel evacuation
- Transformer and cable drying
- Pharmaceutical freeze drying
- Space simulation
- Crystal growing
- Automotive
- Chemical processing

E2M40 Two Stage Rotary Vacuum Pumps



Edwards E2M40 series two stage oil sealed rotary vane vacuum pumps are renowned for their high ultimate vacuum, rapid pumping speeds, quiet operation and ability to handle water vapour. These direct drive rotary vane pumps are inherently compact and vibration free, and with their finger-proof fan and coupling housings they offer excellent operator protection.

A comprehensive range of accessories is available to allow use on the widest variety of vacuum applications.

Supplied with Ultragrade 70 Oil. Fomblin® must be purchased separately for PFPE prepared pumps E2M40FX, E2M80FX, and E2M175FX.

Features & Benefits

- Advanced pressurised oil circuit to give effective lubrication even under high gas loads
- When the pump is switched off, the spring loaded distributor valve provides oil and air suck-back protection
- Gas Ballast control to assist in handling high water vapour loads
- Industrial roller bearings on drive shaft for ultimate reliability and long, trouble free life
- Full height oil sight glass for easy checking of oil level and condition

Applications

- Vacuum metallurgy processes
- Thin film coating technologies
- Pharmaceutical freeze drying
- Refrigeration and air conditioning system evacuation, drying, and backfilling
- Transformer and cable drying and impregnation, insulating oil treatment plant

Dimensions

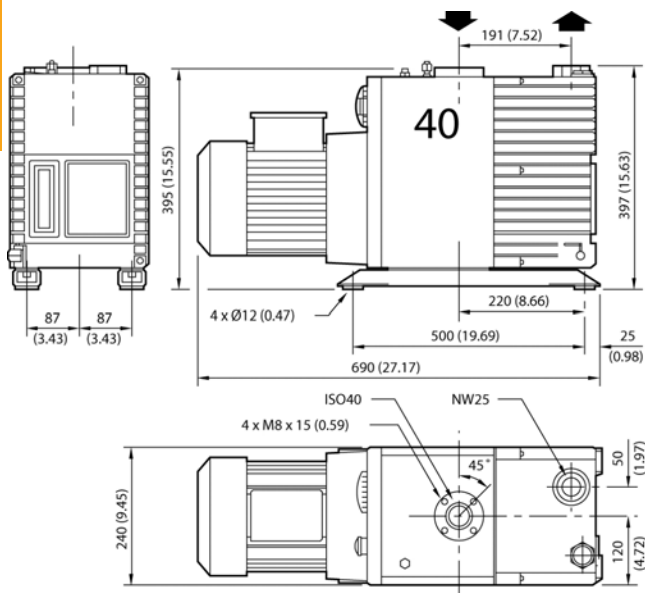

Performance Curves

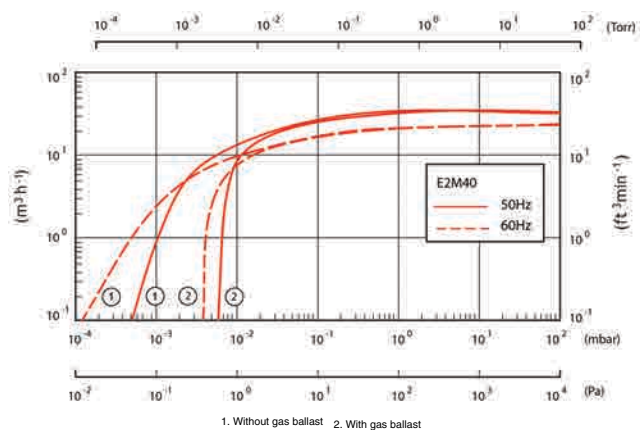

Technical Data

Displacement	
50Hz	42.5 m ³ h ⁻¹ / 25 ft ³ min ⁻¹
60Hz	50.5 m ³ h ⁻¹ / 29.7 ft ³ min ⁻¹
Speed (Pneurop)	
50Hz	37 m ³ h ⁻¹ / 21.8 ft ³ min ⁻¹
60Hz	44 m ³ h ⁻¹ / 25.9 ft ³ min ⁻¹
Number of stages	2
Ultimate vacuum (total pressure)	
Without gas ballast	1 x 10 ⁻³ mbar / 7.7 x 10 ⁻⁴ Torr
With gas ballast	7 x 10 ⁻³ mbar / 5.4 x 10 ⁻³ Torr
Ultimate with Fomblin®	
Without gas ballast	1 x 10 ⁻² mbar
Inlet connection	ISO40
Outlet connection	25 mm flange suitable for NW25
Max outlet pressure	0.5 bar gauge
Max inlet pressure for water vapour	7 mbar / 5.3 Torr
Max water vapour pumping rate	0.2 kg h ⁻¹ / 0.4 lb h ⁻¹
Weight	82 kg / 179 lb
Motor protection rating	IP55
Motor power	
50Hz	1.1 kW / 1.5 hp
60Hz	1.5 kW / 2 hp
Standard oil capacity	
maximum	3.5 litre / 3.2 qt
minimum	1.32 litre / 1.6 qt
PFPE oil capacity	
maximum	3.5 litre / 3.2 qt
minimum	1.32 litre / 1.6 qt
Recommended oil	Ultragrade 70
Noise level	65 dB (A)

Ordering Information

Product Description	Order No.
E2M40 220-240 / 380-415V, 3-ph, 50Hz	A36401935
E2M40 208-230/460V, 3-ph, 60Hz	A36402982
E2M40 200/380V, 3-ph, 50/60Hz	A36401934
E2M40FX 220-240/380-415V, 3-ph, 50Hz	A36411935
E2M40FX 208-230/460V, 3-ph 60Hz	A36412982
E2M40FX 200/380V, 3-ph, 50/60Hz	A36411934
E2M40T4 400V, 3-ph, 50Hz	A36418993
Accessories & Spares	Order No.
Spares Kit C&O E1/2M40 HC/F	A34401131
Spares Kit Blade E1M40	A34401050
Spares Kit Blade E2M40	A36401050
Spares Kit Major E1M40	A34401814
Spares Kit Major Service E2M40	A36401814

E2M80 Two Stage Rotary Vacuum Pumps



Edwards E2M80 series two stage oil sealed rotary vane vacuum pumps are renowned for their high ultimate vacuum, rapid pumping speeds, quiet operation and ability to handle water vapour. These direct drive rotary vane pumps are inherently compact and vibration free, and with their finger-proof fan and coupling housings they offer excellent operator protection.

This pump is suitable for most duties and is safe to handle non-flammable gases and vapours within the normal operating parameters of the pump.

Supplied with Ultragrade 70 Oil. Fomblin® must be purchased separately for PFPE prepared pumps E2M40FX, E2M80FX, and E2M175FX.

Features & Benefits

- Advanced pressurised oil circuit to give effective lubrication even under high gas loads
- When the pump is switched off, the spring loaded distributor valve provides oil and air suck-back protection
- Gas Ballast control to assist in handling high water vapour loads
- Industrial roller bearings on drive shaft for ultimate reliability and long, trouble free life
- Full height oil sight glass for easy checking of oil level and condition

Applications

- Vacuum metallurgy processes
- Thin film coating technologies
- Pharmaceutical freeze drying
- Refrigeration and air conditioning system evacuation, drying, and backfilling
- Transformer and cable drying and impregnation, insulating oil treatment plant

Dimensions

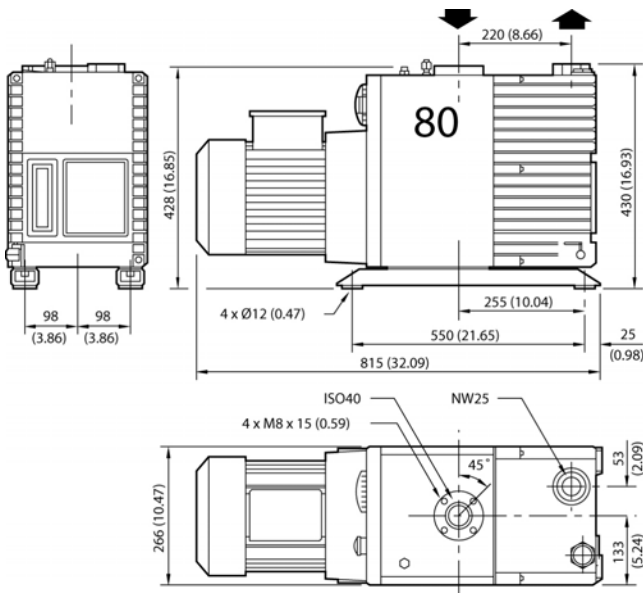

Performance Curves

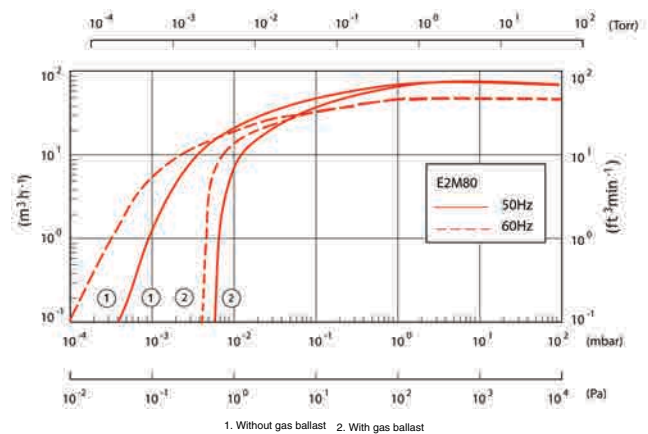

Technical Data

Displacement	
50Hz	80 m ³ h ⁻¹ / 47.1 ft ³ min ⁻¹
60Hz	96 m ³ h ⁻¹ / 56.5 ft ³ min ⁻¹
Speed (Pneurop)	
50Hz	74 m ³ h ⁻¹ / 43.6 ft ³ min ⁻¹
60Hz	90 m ³ h ⁻¹ / 53 ft ³ min ⁻¹
Number of stages	2
Ultimate vacuum (total pressure)	
Without gas ballast	1 x 10 ⁻³ mbar / 7.7 x 10 ⁻⁴ Torr
With gas ballast	7 x 10 ⁻³ mbar / 5.4 x 10 ⁻³ Torr
Ultimate with Fomblin®	
Without gas ballast	1 x 10 ⁻² mbar
Inlet connection	ISO40
Outlet connection	25 mm flange suitable for NW25
Max outlet pressure	0.5 bar gauge
Max inlet pressure for water vapour	5 mbar / 3.8 Torr
Max water vapour pumping rate	0.3 kg h ⁻¹ / 0.7 lb h ⁻¹
Weight	125 kg / 275 lb
Motor protection rating	IP55
Motor power	
50Hz	2.2 kW / 3 hp
60Hz	3 kW / 4 hp
Standard oil capacity	
maximum	6.3 litre / 6.7 qt
minimum	4 litre / 4.2 qt
PFPE oil capacity	
maximum	4.01 litre / 4.2 qt
minimum	2.19 litre / 2.3 qt
Recommended oil	Ultragrade 70
Noise level	70 dB (A)

Ordering Information

Product Description	Order No.
E2M80 220-240/380-415V, 3-ph, 50Hz	A36501935
E2M80 208-230/460V, 3-ph, 60Hz	A36502982
E2M80 200/380V, 3-ph, 50/60Hz	A36501934
E2M80FX 220-240/380-415V, 3-ph, 50Hz	A36511935
E2M80FX, 208-230/460V, 3-ph, 60Hz	A36512982
E2M80FX 200/380V, 3-ph, 50/60Hz	A36511934
E2M80T4 400V, 3-ph, 50Hz	A36518993
Accessories & Spares	Order No.
Spares Kit C&O E1/2M80 HC/F	A34501131
Spares Kit Blade E2M80	A36501050
Spares Kit Blade E1M80	A34501050
Spares Kit Major Service E1M80	A34501814
Spares Kit Major Service E2M80	A36501814

E2M175 Two Stage Rotary Vacuum Pumps



Edwards E2M175 series two stage oil sealed rotary vane vacuum pumps are renowned for their high ultimate vacuum, rapid pumping speeds, quiet operation and ability to handle water vapour. These direct drive rotary vane pumps are inherently compact and vibration free, and with their finger-proof fan and coupling housings they offer excellent operator protection.

This pump is suitable for most duties and is safe to handle non-flammable gases and vapours within the normal operating parameters of the pump.

Supplied with Ultragrade 70 Oil. Fomblin® must be purchased separately for PFPE prepared pumps E2M40FX, E2M80FX, and E2M175FX.

Features & Benefits

- Advanced pressurised oil circuit to give effective lubrication even under high gas loads
- When the pump is switched off, the spring loaded distributor valve provides oil and air suck-back protection
- Gas Ballast control to assist in handling high water vapour loads
- Industrial roller bearings on drive shaft for ultimate reliability and long, trouble free life
- Full height oil sight glass for easy checking of oil level and condition

Applications

- Vacuum metallurgy processes
- Thin film coating technologies
- Pharmaceutical freeze drying
- Refrigeration and air conditioning system evacuation, drying, and backfilling
- Transformer and cable drying and impregnation, insulating oil treatment plant

Dimensions

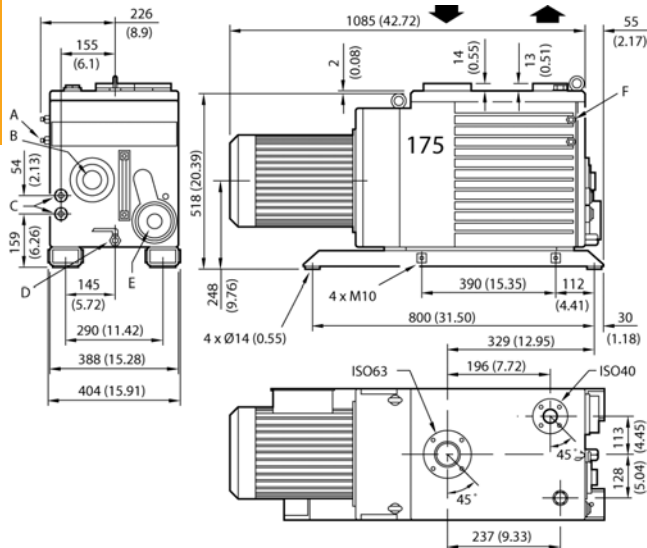

- A Union for oil return connection from oil mist filter
- B Gas ballast control valve
- C Water connections (tapped 3/8 in BSP)
- D Oil drain tap (tapped 1/2 in BSP)
- E Oil filter mounting plate (allow 330mm to withdraw filter from pump)
- F Oil pressure take-off (tapped 1/8 in BSP)

Performance Curves

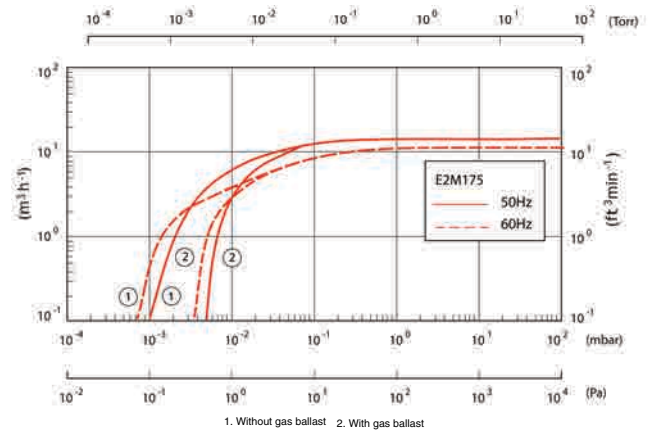

Technical Data

Displacement	
50Hz	178 m ³ h ⁻¹ / 105 ft ³ min ⁻¹
60Hz	214 m ³ h ⁻¹ / 126 ft ³ min ⁻¹
Speed (Pneurop)	
50Hz	160 m ³ h ⁻¹ / 94 ft ³ min ⁻¹
60Hz	196 m ³ h ⁻¹ / 115 ft ³ min ⁻¹
Number of stages	2
Ultimate vacuum (total pressure)	
Without gas ballast	1 x 10 ⁻³ mbar / 7.7 x 10 ⁻⁴ Torr
With gas ballast	7 x 10 ⁻³ mbar / 5.4 x 10 ⁻³ Torr
Ultimate with Fomblin®	
Without gas ballast	1 x 10 ⁻² mbar
Inlet connection	ISO63 blank flange with seal
Outlet connection	ISO40 flange centre tapped
Max outlet pressure	0.5 bar gauge
Max inlet pressure for water vapor	20 mbar / 15 Torr
Max water vapor pumping rate	0.3 kg h ⁻¹ / 0.7 lb h ⁻¹
Weight	230 kg / 508 lb
Motor protection rating	IP55
Motor power	
50Hz	5.5 kW / 7.5 hp
60Hz	6.5 kW / 8.5 hp
Standard oil capacity	
maximum	25 litre / 26 qt
minimum	16 litre / 17 qt
PFPE oil capacity	
maximum	18 litre / 19 qt
minimum	6.5 litre / 6.9 qt
Recommended oil	Ultragrade 70
Noise level	75 dB (A)
Water cooling requirement	1.3 lmin ⁻¹

Ordering Information

Product Description	Order No.
E2M175 220-240/380-415V, 3-ph, 50Hz	A36601935
E2M175 208-230/460V, 3-ph, 60Hz 4 pole	A36603982
E2M175 200/380V, 3-ph, 50/60Hz	A36601934
E2M175FX 220-240/380-415V, 3-ph, 50Hz	A36615935
E2M175FX 208-230/460V, 3-ph, 60Hz	A36616982
E2M175T3 220-240/380-415V, 3-ph, 50Hz	A36618993
Accessories & Spares	Order No.
Spares Kit C&O E1M175/275S	A34601131
Spares Kit C&O E2M175/275	A36601131
Service Interior Assy E1M175	A34601100
Service Interior Assy E2M175	A36601100
Spares Kit Blade E2M175	A36601134
Spares Kit Blade Springless E1M175	A34601134
Spares Kit Major E1M175S	A34601831
Spares Kit Major Service E2M175	A36601831

E2M275 Two Stage Rotary Vacuum Pumps



Edwards E2M275 series two stage oil sealed rotary vane vacuum pumps are renowned for their high ultimate vacuum, rapid pumping speeds, quiet operation and ability to handle water vapour. These direct drive rotary vane pumps are inherently compact and vibration free, and with their finger-proof fan and coupling housings they offer excellent operator protection.

This pump is suitable for most duties and is safe to handle non-flammable gases and vapours within the normal operating parameters of the pump. Supplied with Ultragrade 70 Oil.

Features & Benefits

- Advanced pressurised oil circuit to give effective lubrication even under high gas loads
- When the pump is switched off, the spring loaded distributor valve provides oil and air suck-back protection
- Gas Ballast control to assist in handling high water vapour loads
- Industrial roller bearings on drive shaft for ultimate reliability and long, trouble free life
- Full height oil sight glass for easy checking of oil level and condition

Applications

- Vacuum metallurgy processes
- Thin film coating technologies
- Pharmaceutical freeze drying
- Refrigeration and air conditioning system evacuation, drying, and backfilling
- Transformer and cable drying and impregnation, insulating oil treatment plant

Dimensions

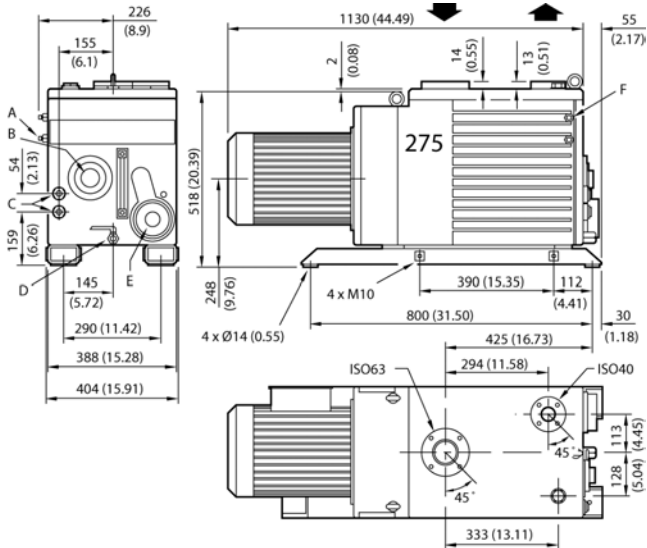

- A Union for oil return connection from oil mist filter
- B Gas ballast control valve
- C Water connections (tapped 3/8 in BSP)
- D Oil drain tap (tapped 1/2 in BSP)
- E Oil filter mounting plate (allow 330mm to withdraw filter from pump)
- F Oil pressure take-off (tapped 1/8 in BSP)

Performance Curves

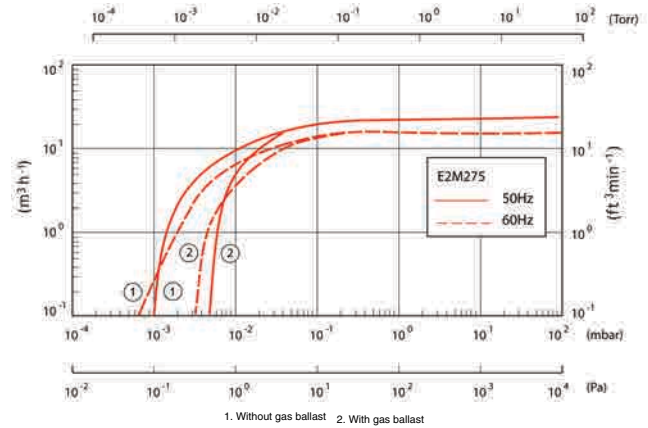

Technical Data

Displacement	
50Hz	292 m ³ h ⁻¹ / 172 ft ³ min ⁻¹
60Hz	350 m ³ h ⁻¹ / 206 ft ³ min ⁻¹
Speed (Pneurop)	
50Hz	255 m ³ h ⁻¹ / 150 ft ³ min ⁻¹
60Hz	306 m ³ h ⁻¹ / 180 ft ³ min ⁻¹
Number of stages	
	2
Ultimate vacuum (total pressure)	
Without gas ballast	1.0 x 10 ⁻³ mbar / 7.7 x 10 ⁻⁴ Torr
With gas ballast	5.0 x 10 ⁻³ mbar / 3.8 x 10 ⁻³ Torr
Inlet connection	
	ISO63 blank flange with seal
Outlet connection	
	ISO40 flange centre tapped
Max outlet pressure	
	0.5 bar gauge
Max inlet pressure for water vapour	
	12 mbar / 9 Torr
Max water vapour pumping rate	
	2.3 kg h ⁻¹ / 5.1 lb h ⁻¹
Weight	
	253 kg / 558 lb
Motor protection rating	
	IP55
Motor power	
50Hz	7.5 kW / 10 hp
60Hz	8.5 kW / 11 hp
Standard oil capacity	
maximum	28 litre / 29.5 qt
minimum	19 litre / 20 qt
Recommended oil	
	Ultragrade 70
Noise level	
	75 dB (A)
Water cooling requirement	
	2 lmin ⁻¹

Ordering Information

Product Description	Order No.
E2M275 220-240/380-415V, 3-ph, 50Hz	A36701935
E2M275 208-230/460V, 3-ph, 60Hz	A36703982
E2M275 200/380V, 3-ph, 50/60Hz	A36701934
E2M275T3 400V, 3-ph, 50Hz	A36718993
Accessories & Spares	Order No.
Spares Kit C&O E1M175/275S	A34601131
Spares Kit C&O E2M175/275	A36601131
Service Interior Assy E1M275	A34701100
Service Interior Assy E2M275	A36701100
Spares Kit Blade E2M275	A36701134
Spares Kit Blade Springless E1M275	A34701134
Spares Kit Major E1M275S	A34701831
Spares Kit Major Service E2M275	A36701831

Large Pump Accessories

MF Outlet Mist Filters

The MF30, MF100 and MF300 mist filters are suitable for pumps from E2M28 to E2M275. They are very efficient at 99.85% DOP test (pre-wetted filter; 99.5% with dry element). The oil level sight-glass provides easy monitoring of mist filter status.

The MF100AE is a version of the MF100, designed for use with corrosive gases and vapours and for greater security when processing toxic substances. It is very efficient at 99.1% DOP test (pre-wetted; 98.4% with dry element). This version is leak tested to 1×10^{-4} mbar l s⁻¹ / 3.8×10^{-3} Torr. The filter element, sight-glasses and seals are resistant to chemical attack. The MF100AE is fitted with an acrylic sight-glass (for use with fluorinated processes); a glass sight-glass is also supplied with the filter (for use with chlorinated processes).

A version of the EMF clean application oil return kit is available for all the MF filters, except the MF100AE.

Ordering Information

Product Description	Order No.
Model MF100 mist filter (12 kg/26.5 lb)*	A46203000
Model MF100AE mist filter (12 kg/26.5 lb)*	A46211000
Model MF300 mist filter (28 kg/62 lb)†	A46204000
* Supplied with two NW25 "C" clamps, NW25 elbow, two NW25 centring-ring and O-rings, bolts, washers, mounting brackets and studs	
† Supplied with two ISO40 "C" clamps, ISO40 elbow, two 40 mm Co-Seals, bolts, washers, mounting brackets and studs	
Accessories	Order No.
Clean application oil return kit (E1M40 to E2M80)	A50004000
Clean application oil return kit (E1M175 to E2M275)	A50005000
Spares	Order No.
MF100	A22304020
MF100AE	A22304052
MF300	A22304021
Spares kits	
MF100, MF100AE	A46203800
MF300	A46204800
MF100AE sight-glass kit	A50080000

CP Outlet Catchpots

In some industrial applications it is desirable for pumps to be provided with piped exhaust arrangements to carry gases and vapours to the outside of the building.

There is always a risk that some vapour carried out with the effluent gas will cool and condense as it travels up the exhaust line and the liquid produced will drain back into the pump causing serious contamination.

For this reason, it is good practice to use a catchpot between the pump outlet and the exhaust line to prevent this from happening. These catchpots are designed for fitting directly to the pump outlet, or can be remotely mounted if required. A "high level" sight glass is provided to indicate the need for draining the catchpot when the nominal capacity is reached. A drain plug is also provided.

Note: When an oil mist filter is used, a separate catchpot is generally unnecessary.

Ordering Information

Product Description	Order No.
Model CP100 outlet catchpot, 6.5 litre/6.2 qt capacity (12.0 kg/26.5 lb)*	A46103000
Model CP300 outlet catchpot, 23.0 litre/22 qt capacity (28.0 kg/62 lb)†	A46104000
* Supplied with two NW25 "C" clamps, NW25 elbow, two NW25 centring-rings and O-rings, bolts, washers, mounting bracket and studs.	
† Supplied with two ISO40 "C" clamps, ISO40 elbow, two 40 mm O-rings and centring-rings, bolts, washers, mounting brackets and studs.	

External Oil Filters: EOF100A/300A (Chemical) and EOF100M/300M (Dust)

These filters are operated by the internal pressurized oil system of the pump, which by-passes a proportion of the oil through the filter. The filters are easy to install – just connect the flexible hoses supplied to the oil outlet and return connectors on the pump. The oil capacities are approximately 6 litres / 5.7 qt (EOF100) and 15 litres / 14.3 qt (EOF300).

The EOF100A and EOF300A chemical filters have a renewable high-capacity, activated earth element. The filters purify the oil by removing acidic and other aggressive contaminants. These filters are intended for use with hydrocarbon oils, and they will greatly increase the interval between oil changes.

The EOF100M and EOF300M dust filters have pleated paper elements which trap small dust particles (down to 0.5 micron diameter). Use these filters for applications which produce large quantities of abrasive dust (for example, vacuum furnaces).

Ordering Information

Product Description	Order No.
External oil filter, without connection kit	
EOF100A	A50024000
EOF100M	A50025000
External oil filter, with E1M/E2M175 and 275 connection kit	
EOF300A	A50003000
EOF300M	A50023000
Connection kit for E1M/E2M40 and E1M/E2M80	
EOF100A and M	A50039000
EOF300A and M	A36401020
Product Description	Order No.
Activated earth element	
EOF100A	A22304043
EOF300A	A22304033
Dust filter element	
EOF100M	A22304044
EOF300M	A22304042

Vibration Isolators

You may need to fit vibration isolators to your pump if you mount it into a frame or system, if the mounting points are not level or if you need to minimise the transmission of vibration and noise in your application. You must fit flexible bellows or other flexible pipes to the pump inlet and outlet.

Ordering Information

Pump	Approximate Reduction in Height with Pump Fitted (mm)	Weight Set of Four	Order No.
E1M40/E2M40	.5	0.6 kg/1.3 lb	A24801405
E1M80/E2M80	2.5	0.6 kg/1.3 lb	A24801405
E1M175/E2M175	3	0.9 kg/2 lb	A24801406
E1M275/E2M275	3.5	0.9 kg/2 lb	A24801406

Details of vibration isolators for use with rotary/mechanical booster pump combinations are available on request.

OLM100 Oil Level Monitor

Fit the OLM100 in place of the oil sight glass on the E1M/E2M 40 and 80 pumps. The OLM100 continues to allow visual inspection of the oil level and condition, while also providing a switched output for remote indication. Technical data: 24 V a.c. or d.c., maximum current 0.5 A, switching power 10 W (12 VA).

Ordering Information

Product Description	Order No.
OLM100 oil level monitor	A50433000

EBV Gas Ballast Control Valves

Fit the EBV valve (EBV20 for RVs and E2M1.5 to E2M28, EBV300D for E2M40, 80, 175 and 275) to allow remote operation of the pump's gas ballast control. For example, the EBV can be configured to switch off the gas ballast when the pump is switched off, to provide suck-back protection. The EBV can also be configured to prevent the 175 and 275 from running backwards when the gas ballast valve is open and the pumps are stopped under vacuum.

Ordering Information

Product Description	Order No.
EBV20 (0.5 kg) 220 – 240 V s.ph 50/60 Hz	A50006930
EBV300D (1.0 kg) 220 – 240 V s.ph 50/60 Hz	A50017930

TCV300 Temperature Control Valve

Use the TCV300 with the E1M/E2M175 and 275 pumps. The valve facilitates rapid pump warm-up and higher operation temperatures. This improves the pump's vapour pumping performance. The TCV300 also reduces the use of cooling water and reduces operation costs.

Ordering Information

Product Description	Order No.
TCV300 (1.2 kg/2.6 lb)	A50001000

ITF Inlet Dust Filters

The ITF inlet dust filters prevent the entry of dust particles into the pump. The impedance of a clean filter reduces the pumping speed of a 20 m³h⁻¹ / 12 ft³min⁻¹ pump by about 20% at 1 mbar / 0.75 Torr and 25% at 10 mbar / 7.5 Torr.

Depending on your application, you can normally clean the filter element with a vacuum cleaner or a clean air blast, and then re-use the element.

The benefits of the ITF filters include:

- Thick aluminium casting, to withstand abrasion
- Tangential entry port, to promote centrifugal separation of dust particles
- Filter efficiency better than 96% (tested to BS2831, dust number 2)

Ordering Information

Product Description	Order No.
ITF100 inlet dust filter (7.0 kg/15 lb)*	A44202000
ITF300 inlet dust filter (8.3 kg/18 lb) [†]	A44203000
ITF800 inlet dust filter (20.2 kg/44 lb)**	A44204000
ITF3000 inlet dust filter ^{††}	A44212000

* Supplied with bolts, washers, 40 mm O-ring and centring-ring

[†] Supplied with 63 mm Co-Seal, bolts and washers

** Supplied with 100 mm Co-Seal, bolts and washers

^{††} Supplied with 160 mm Co-Seal, bolts and washers

Spares	Order No.
ITF100 element and gasket kit	A44202800
ITF300 element and gasket kit	A44203800
ITF800 element and gasket kit	A44204800
ITF3000 element (2 required)	A22304037

ITM High Capacity Inlet Dust Filters

The ITM deep, stainless steel mesh elements are ideal for applications where fast pump-down times are required and which produce high levels of dust and grit (which would normally clog the ITF filters very quickly). You can wet the stainless steel mesh element with oil to improve dust adhesion. You can wash the mesh elements and re-use them indefinitely.

The benefits of the ITM filters include:

- Thick aluminium casting, to withstand abrasion
- Tangential entry port, to promote centrifugal separation of dust particles
- Filter efficiency better than 90% (tested to BS2831, dust number 2)
- Glass cover, to allow a visual check of the filter element

Ordering Information

Product Description	Order No.
ITM100 high capacity dust filter (7.2 kg/16 lb)*	A44302000
ITM300 high capacity dust filter (8.7 kg/19 lb) [†]	A44303000
ITM800 inlet dust filter (20.2 kg/44 lb)**	A44304000
ITM3000 inlet dust filter ^{††}	A44312000
ITM5000 inlet dust filter	A44313000

* Supplied with bolts, washers, 40 mm O-ring and centring-ring

[†] Supplied with 63 mm Co-Seal, bolts and washers

** Supplied with 100 mm Co-Seal, bolts and washers

^{††} Supplied with 160 mm Co-Seal, bolts and washers

Spares	Order No.
ITM100 filter element	A22305020
ITM300 filter element	A22305019
ITM800 filter element	A22305018
ITM3000 filter element (2 required)	A22305033

ITO Inlet Catchpots

These catchpots minimise the entry of condensable vapours into the pump. Benefits of the catchpots include:

- Capture condensable vapours
- Helps prevent froth or spray from the process from carrying over to the pump
- Corrosion-resistant body
- Visual indication of trapped liquid level
- Hand-tightened drain plug, for easy drainage

Ordering Information

Product Description	Order No.
ITO100 inlet catchpot, 5.47 litres/5.2 qt capacity (6.8 kg, 15 lb)*	A44102000
ITO300 inlet catchpot, 7.87 litres/7.5 qt capacity (8.0 kg/18 lb)†	A44103000
IT0800 inlet catchpot, 9.5 litres/10 qt capacity (19.5 kg/43 lb)**	A44104000

* Supplied with bolts, washers, 40 mm O-ring and centring-ring
† Supplied with 63 mm Co-Seal, bolts and washers
** Supplied with 100 mm Co-Seal, bolts and washers

ITC Inlet Chemical Traps

The ITC series of chemical traps provides the following benefits:

- Protection against various aggressive vapours, which may attack the pump or pump oil
- Prevent high molecular weight vapours (such as might arise in a resin treatment plant), from reaching the pump. These vapours could cause lacquering or clogging
- The standard sorbent (activated charcoal), has relatively high trapping properties (absorbs around 25% of its own weight), even when large amounts of water vapour are being pumped
- When filled with activated alumina on two-stage pumps, backstreaming of pump oil can be controlled

Ordering Information

Product Description	Order No.
ITC100 inlet chemical trap*	A44402000
Charcoal charge 0.75 kg/1.7 lb, weight 16.5 kg/1.7 lb	
ITC300 inlet chemical trap†	A44403000
Charcoal charge 1.1 kg/2.4 lb, weight 9 kg/20 lb	
ITC800 inlet chemical trap**	A44404000
Charcoal charge 3.3 kg/2.4 lb, weight 21 kg/20 lb	

* Supplied with bolts, washers, 40 mm O-ring and centring-ring
† Supplied with 63 mm Co-Seal, bolts and washers
** Supplied with 100 mm Co-Seal, bolts and washers

Spares	Order No.
0.5 kg/1.1 lb activated charcoal	H12205001
3 kg/6.6 lb activated charcoal	H12205002
0.45 kg/1 lb activated alumina	H02600050
0.2 kg/0.5 lb activated alumina	H02600056

Ordering Information – All Territories Except North America

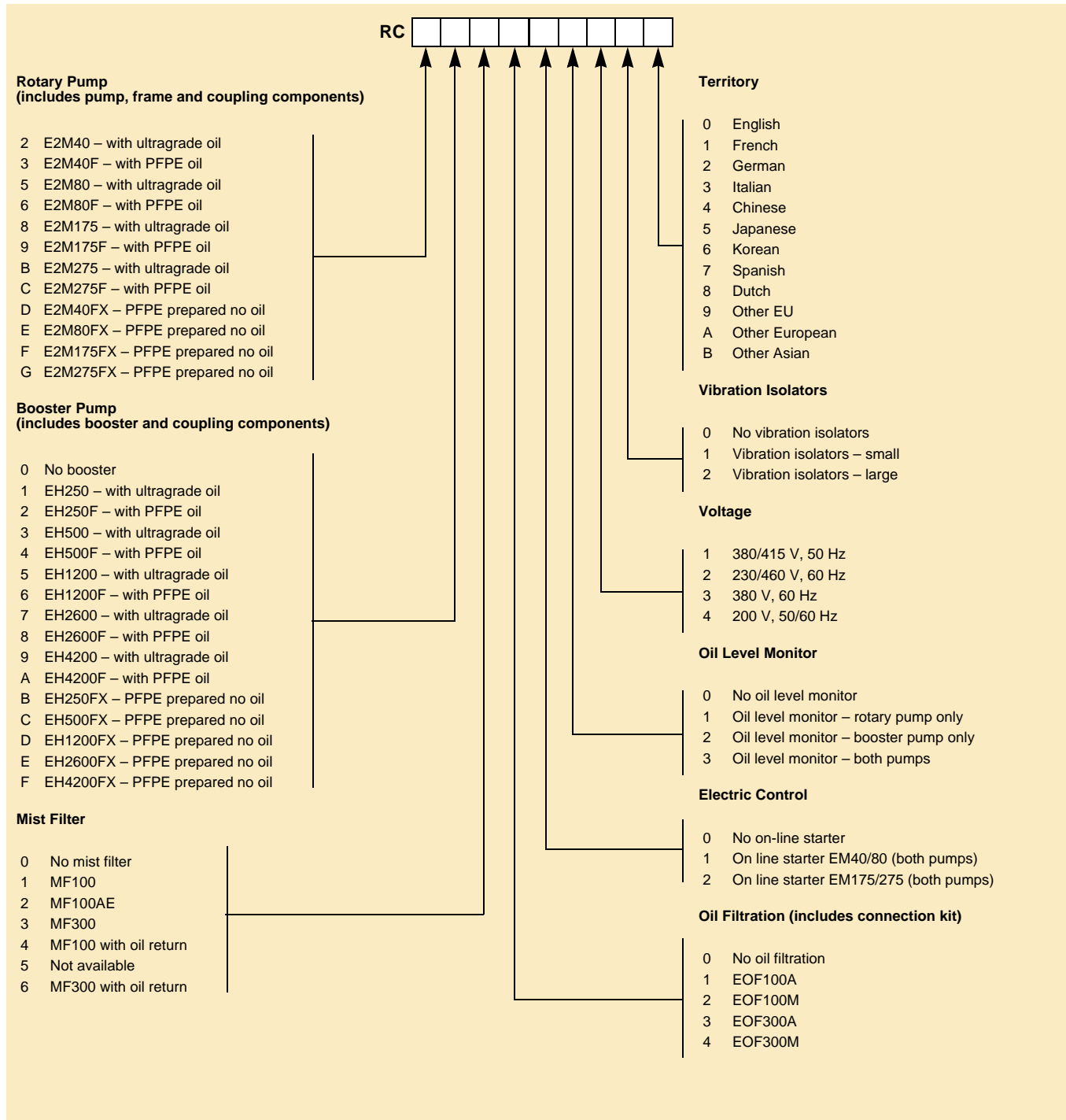

Ordering Information – North America

DM - -

DM – Simple Direct Mount, fully assembled system and tested

G - -

G – Easy Roll Around Frame, fully assembled system and tested

Rotary Pump (includes pump, frame, and coupling components)

- 0 None
- 1 E2M40
- 2 E2M80
- 3 E2M40 + oil level
- 4 E2M80 + oil level
- B E2M175
- C E2M275

Booster Pump (includes booster and coupling components)

- 0 None
- 1 EH250
- 2 EH500
- 3 EH1200
- 4 EH250 + oil level
- 5 EH500 + oil level
- 6 EH1200 + oil level
- 7 EH2600
- 8 EH4200

Mist Filter

- 0 None
- 1 MF100AE (for E1/E2M40, E1/E2M80)
- 2 MF100AE with semi-automatic oil return
- 3 MF100AE with oil return
- 7 MF300
- 8 MF300 with semi-automatic oil return
- 9 MF300 with oil return

Oil Filtration (includes connection kit)

- 0 None

Oil (prices included with pump)

- 0 None-PFPE prepared only
- 2 PFPE
- 3 Edwards TW
- 4 Ultragrade oil

Electrical Supply (no additional charge)

- 0 None*
- 1 208 V, 60 Hz
- 2 230 V, 60 Hz
- 3 460 V, 60 Hz
- 4 575 V, 60 Hz
- 5 220 V, 60 Hz
- 6 380 V, 60 Hz
- 7 415 V, 60 Hz

Electrical Controls – motor control module, stop/start switches and interlocks (credit)

- S Controls Supplied
- X No Controls Supplied
 - EH250, EH500 and EH1200 Combinations
 - EH2600 and EH4200 Combinations

Flow Control

- 0 None
- 1 Dry Nitrogen Box Purge (OB100)
- 2 Dry Nitrogen Gas Ballast

Stokes Microvac Series Oil Sealed Rotary Piston Pumps



In today's globally competitive environment, the need for manufacturing and process equipment delivers maximum performance and reliability is greater than ever. Whether you operate at low pressure, handle large gas loads, or simply need increased capacity for your existing system, Edwards can help meet your pumping requirements.

Rugged, Reliable Operation

Every design consideration, feature and detail is thoroughly engineered to maximize uptime and extend operating life. Below are just a few features that testify to the integrity of these rugged multistage vacuum pumps.

- Efficient, time proven design to deliver ease of maintenance
- Low 500 rpm operation for longest pump life cycle
- Low ultimate blank-off – pressures down to $< 10^{-2}$ Torr
- Robust cast and ductile iron construction
- Hardened replaceable shaft sleeve enhances wear resistance
- Efficient design provides maximum uptime with minimal moving parts, low rotational speed and large clearance
- New valve design virtually eliminates valve maintenance and noise
- Application specific seals maximize resistance to heat and corrosion while providing protection from gas stream oil contamination
- Standard, totally enclosed fan-cooled motors
- Space saving design – saves up to 50% of valuable floor space
- Complete and self-contained – delivered and ready to install
- Automatic lubrication – system provides proper flow of oil to bearings and sealing surfaces, prevents back flow into system
- Controlled balancing – reduces vibration to a practical minimum
- Gas ballast- standard on all models
- Total capability – includes the manufacturing and service capabilities to keep your equipment in top operation – with a broad range of vacuum system accessories
- Oxygen service models available

Solutions to Fit Your Needs

Our total vacuum capabilities include a full line of pumping systems from 150 to 7880 ft³min⁻¹ capacities. Choose from Stokes microvac rotary piston pump (J series), Stokes 1700 series high capacity mechanical booster pump combinations, and MV Series Matrix selection series mechanical booster packages, or a custom designed package to meet all your pumping needs.

J Series Overview

The Stokes J series microvac rotary piston pump sets the standard for performance and reliability as the industry's most efficient, space-saving design. The Stokes microvac rotary piston pump has been improved, upgraded, and fine-tuned to deliver even better dependability and productivity combined with minimal maintenance and process downtime.

An integral oil distribution system eliminates external piping and delivers leak-free operation in a more stylized design for the J series. A larger oil sight glass and paddle wheel design flow indicator provides easier viewing of the oil system function. A stiffer motor mounting platform cuts flexibility to minimise motor belt wear. A stylized oil reservoir cover and side cover O-rings improve sealing to eliminate oil leakage. An integral gas ballast valve built into the side cover allows quick adaptation to automatic gas ballast.

Most importantly, these improvements don't increase the industry leading space saving footprint. Inlet, outlet and mounting dimensions are exactly the same as the H series microvac rotary piston pump.

Applications

- Automotive
- General applications
- Metallurgy
- Vacuum coating
- Vacuum melting
- Chemical processing
- Heat treatment
- Leak detection
- PET processing
- Pharmaceuticals
- Transformer drying and cable fluid conditioning

By combining over a century of technical experience with a global sales and service network, Edwards adds value to your process. Our applications specialists can offer advice on a single pump or component through to a complete pumping system, custom tailored to your specifications.

Stokes Microvac Model 212J



The Stokes Microvac rotary piston pump sets the standard for performance and reliability as the industries most efficient, space-saving design. The Stokes Microvac rotary piston pump has been improved, upgraded, and fine-tuned to deliver even better dependability and productivity combined with minimal maintenance and process downtime.

An integral oil distribution system eliminates external piping and delivers leak-free operation in a stylized design. A stiffer motor mounting platform cuts flexibility to minimize motor belt wear. A stylized oil reservoir cover and side cover 'O' rings improve sealing to eliminate oil leakage. An integral gas ballast valve built into the side cover allows quick adaptation to automatic gas ballast.

Dimensions

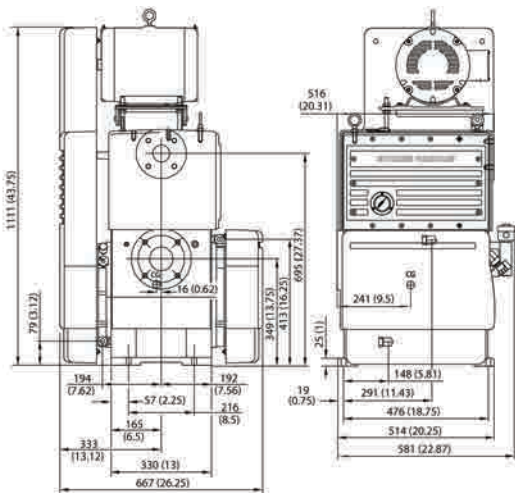

Performance Curves

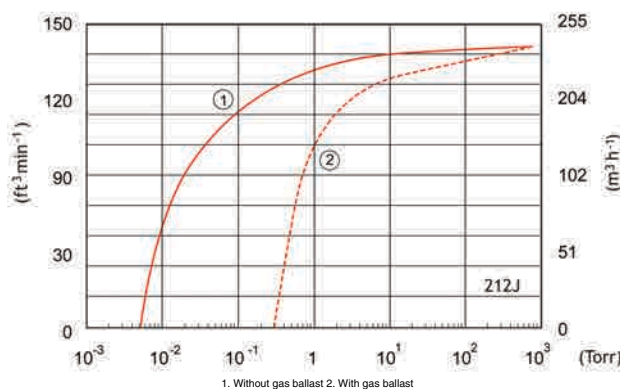

Technical Data

Displacement (swept volume)	$255 \text{ m}^3 \text{ h}^{-1} / 150 \text{ ft}^3 \text{ min}^{-1}$
Pumping Speed	$234 \text{ m}^3 \text{ h}^{-1} / 138 \text{ ft}^3 \text{ min}^{-1}$
Ultimate vacuum (total pressure)	
without gas ballast	$<3.3 \times 10^{-2} \text{ mbar} / <2.5 \times 10^{-2} \text{ Torr}$
with gas ballast	$<2.6 \times 10^{-2} \text{ mbar} / <2 \times 10^{-2} \text{ Torr}$
50Hz Motor size (TEFC)	5.5 kW IEC (CE variant)
60Hz Motor size (TEFC)	7.5 hp TEFC
Motor speed	1800 rpm
Inlet connection	3 inch ASA/ANSI flange
Exhaust connection	2 inch ASA/ANSI flange or 2 inch NPT
Water inlet/outlet connection	½ inch NPT
Recommended cooling flow @ 85°C / 30°F	$5.7 \text{ lmin}^{-1} / 1.5 \text{ galmin}^{-1}$
Water vapour pumping rate	$5 \text{ kg h}^{-1} / 11 \text{ lb h}^{-1}$
Oil capacity	15 litre / 4 gal
Recommended oil	V lube F
Noise	<77 dB(A)
Weight	431 kg / 950 lbs

Ordering Information

Product Description	Order No.
212J 230/460V, 3Ø, 60Hz (230/460V Coil)	900212014
212J 400V, 3-ph, 50Hz, IEC motor, 380V Coil (CE compliant)	900212014501
212J 400V, 3-ph, 50Hz, IEC motor, 415V Coil (CE compliant)	900212014502
212J 400V, 3-ph, 50Hz, IEC motor, 380V Coil with Water Miser (CE compliant)	900212014503
212J 400V, 3-ph, 50Hz, IEC motor 415V Coil with Water Miser (CE compliant)	900212014504
Accessories & Spares	Order No.
Replacement parts kit	429638016
Bearings	085019757
Valve deck assembly	607417001

Stokes Microvac Model 412J

The Stokes Microvac rotary piston pump sets the standard for performance and reliability as the industries most efficient, space-saving design. The Stokes Microvac rotary piston pump has been improved, upgraded, and fine-tuned to deliver even better dependability and productivity combined with minimal maintenance and process downtime.

An integral oil distribution system eliminates external piping and delivers leak-free operation in a stylized design. A stiffer motor mounting platform cuts flexibility to minimize motor belt wear. A stylized oil reservoir cover and side cover 'O' rings improve sealing to eliminate oil leakage. An integral gas ballast valve built into the side cover allows quick adaptation to automatic gas ballast.



Dimensions

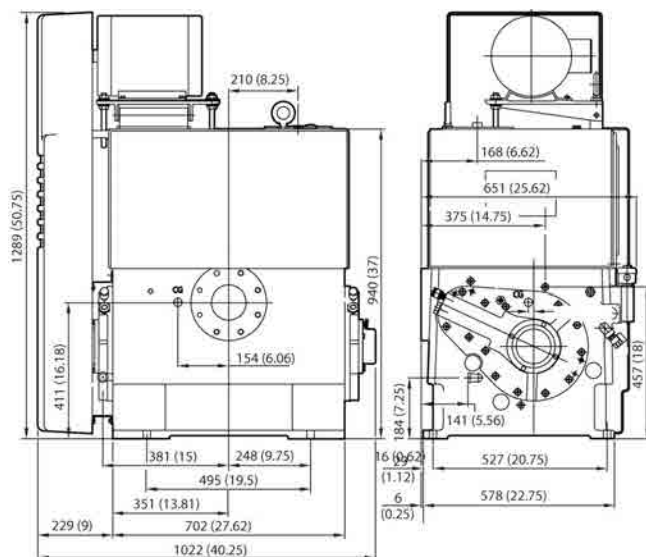

Performance Curves

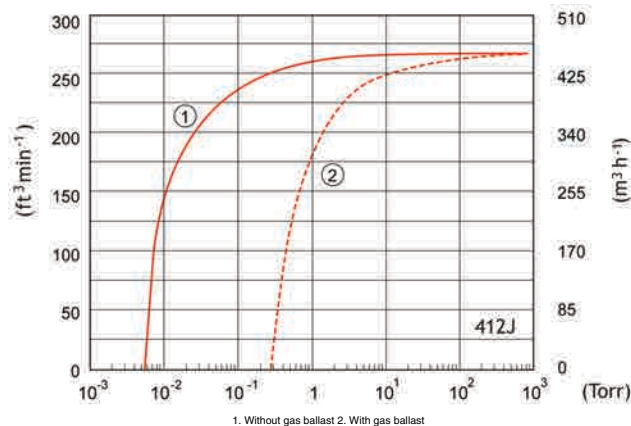

Technical Data

Displacement (swept volume)(AVS)	510 m ³ h ⁻¹ / 300 ft ³ min ⁻¹
Pumping Speed	442 m ³ h ⁻¹ / 260 ft ³ min ⁻¹
Ultimate vacuum (total pressure)	
without gas ballast	<3.3x10 ⁻² mbar / <2.5x10 ⁻² Torr
with gas ballast	<2.6x10 ⁻¹ mbar / <2x10 ⁻¹ Torr
50Hz Motor size	11 kW IEC (CE variant)
60Hz Motor size	10 hp TEFC
Motor speed	1800 rpm
Inlet connection	4 inch ASA/ANSI flange
Exhaust connection	3 inch ASA/ANSI flange or 3 inch NPT
Water inlet/outlet connection	½ inch NPT
Recommended cooling flow @ 85°C / 30°F	7.6 lmin ⁻¹ / 1.5 galmin ⁻¹
Water vapour pumping rate	10.45 kg h ⁻¹ / 23 lb h ⁻¹
Oil capacity	46 litre / 12 gal
Recommended oil	V lube F
Noise level	<83 dB(A)
Weight	794 kg / 1750 lbs

Ordering Information

Product Description	Order No.
412J 230/460V, 3Ø, 60Hz (230/460V Coil)	900412014
412J 400V, 3-ph, 50Hz, IEC motor 380V Coil (CE compliant)	900412014501
412J 400V, 3-ph, 50Hz, IEC motor 415V Coil (CE compliant)	900412014502
412J 400V, 3-ph, 50Hz, IEC motor, 380V Coil with Water Miser (CE compliant)	900412014503
412J 400V, 3-ph, 50Hz, IEC motor 415V Coil with Water Miser (CE compliant)	900412014504
Accessories & Spares	Order No.
Replacement parts kit	429638015
Bearings	085019757
Valve deck assembly	607417001

Stokes Microvac Model 612J



The Stokes Microvac rotary piston pump sets the standard for performance and reliability as the industry's most efficient, space-saving design. The Stokes Microvac rotary piston pump has been improved, upgraded, and fine-tuned to deliver even better dependability and productivity combined with minimal maintenance and process downtime.

An integral oil distribution system eliminates external piping and delivers leak-free operation in a stylized design. A stiffer motor mounting platform cuts flexibility to minimize motor belt wear. A stylized oil reservoir cover and side cover 'O' rings improve sealing to eliminate oil leakage. An integral gas ballast valve built into the side cover allows quick adaptation to automatic gas ballast.

Dimensions

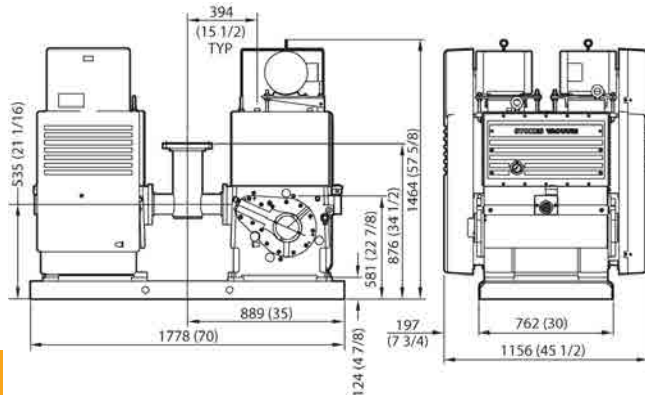

Performance Curves

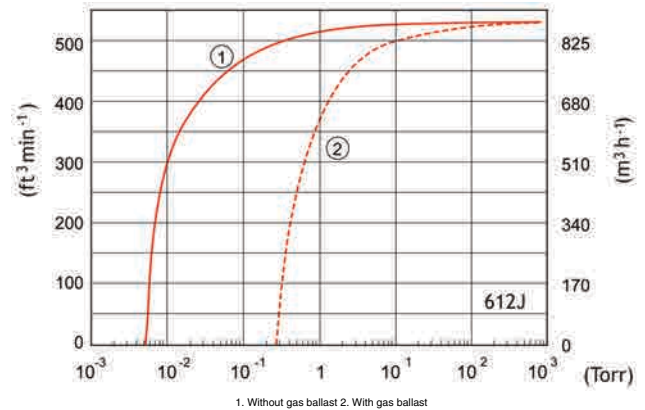

Technical Data

Displacement (swept volume)	1020 m ³ h ⁻¹ / 600 ft ³ min ⁻¹
Pumping speed	884 m ³ h ⁻¹ / 520 ft ³ min ⁻¹
Ultimate vacuum (total pressure)	
without gas ballast	<3.3 x 10 ⁻² mbar / <2.5 x 10 ⁻² Torr
with gas ballast	<2.6 x 10 ⁻¹ mbar / <2 x 10 ⁻¹ Torr
50Hz Motor size	11 kW IEC (CE variant) (x2)
60Hz Motor size	10 hp TEFC (x2)
Motor speed	1800 rpm
Inlet connection	6 inch ASA/ANSI flange
Exhaust connection	2 x 3 inch ASA/ANSI flange or 3 inch NPT
Cooling medium	Water
Water inlet/outlet connection	2 x 1/2 inch NPT
Recommended cooling flow @ 85°F / 30°C	7.6 lmin ⁻¹ / 1.5 galmin ⁻¹ (x2)
Water vapour pumping rate	20.9 kg h ⁻¹ / 46 lb h ⁻¹
Oil capacity	92 litre / 24 gal
Recommended oil	V lube F
Noise level	<85 dB(A)
Weight	1724 kg / 3800 lbs

Ordering Information

Product Description	Order No.
612J 230/460V, 3-ph, 60Hz (230/460V Coil)	900612014
Accessories & Spares	Order No.
Replacement parts kit	429638015
Bearings	085019757
Valve deck assembly	607417001

Stokes Microvac Model 912J

The Stokes Microvac rotary piston pump sets the standard for performance and reliability as the industry's most efficient, space-saving design. The Stokes Microvac rotary piston pump has been improved, upgraded, and fine-tuned to deliver even better dependability and productivity combined with minimal maintenance and process downtime.

An integral oil distribution system eliminates external piping and delivers leak-free operation in a stylized design. A stiffer motor mounting platform cuts flexibility to minimize motor belt wear. A stylized oil reservoir cover and side cover 'O' rings improve sealing to eliminate oil leakage. An integral gas ballast valve built into the side cover allows quick adaptation to automatic gas ballast.



Dimensions

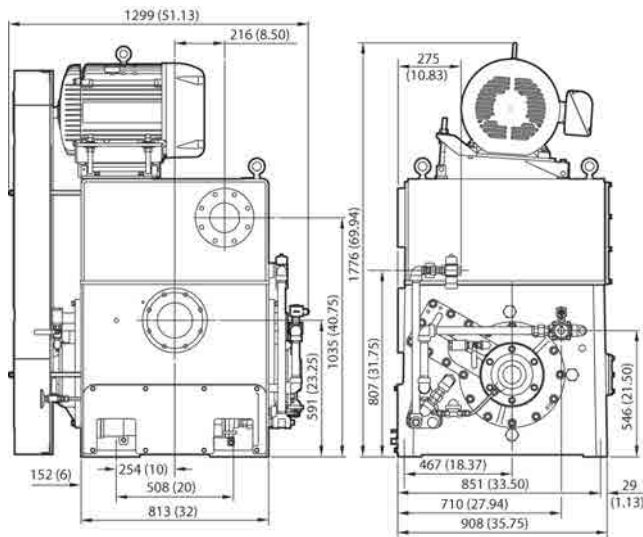

Performance Curves

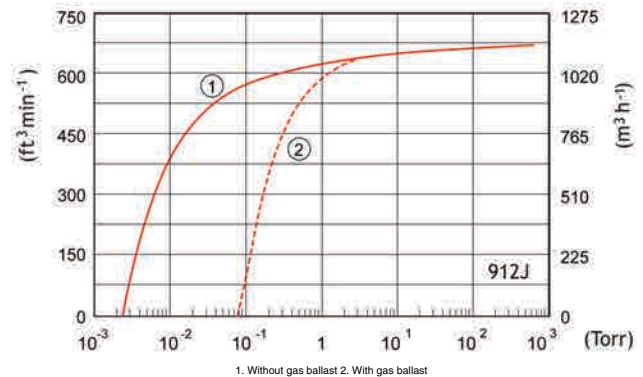

Technical Data

Displacement (swept volume)(AVS)	1240 m ³ h ⁻¹ / 728 ft ³ min ⁻¹
Pumping speed	1132 m ³ h ⁻¹ / 670 ft ³ min ⁻¹
Ultimate vacuum (total pressure)	
without gas ballast	<3.3 x 10 ⁻² mbar / <2.5 x 10 ⁻² Torr
with gas ballast	<2.6 x 10 ⁻¹ mbar / <2 x 10 ⁻¹ Torr
50Hz Motor size	22 kW TEFC
60Hz Motor size	30 hp TEFC
Motor speed	1800 rpm
Inlet connection	6 inch ASA/ANSI flange
Exhaust connection	5 inch NPT
Cooling medium	Water
Water inlet/outlet connection	1 inch NPT
Recommended cooling flow @ 85°C / 30°F	18.9 lmin ⁻¹ / (2) / 5 galmin ⁻¹
Water vapour pumping rate	27.27 kg h ⁻¹ / 60 lb h ⁻¹
Oil capacity	92 litre / 24 gal
Recommended oil	V lube F
Noise level	<85 dB(A)
Weight	2495 kg / 5500 lbs

Ordering Information

Product Description	Order No.
912J 230/460V, 3-ph, 60Hz (230/460V Coil)	900912010
Accessories & Spares	Order No.
Replacement roller bearing	085033795
Replacement oil seal	085018191
Roller bearing with adaptive sleeve	085033794
Valve deck stainless steel clappers	272963002
Valve deck springs	247172001

Stokes Microvac Accessories

Water Miser

Features & Benefits

- Saves cooling water, improves efficiency
- Remote bulb temperature sensor in oil reservoir of vacuum pump
- Throttles valve on cooling water to control oil temperature
- Fits most water cooled vacuum pumps

Ordering Information

Product Description	For Pump	Order No.
Water Miser	149H-412J	900412124

Gas Ballast Silencer

Features & Benefits

- Cuts noise level
- Simple thread-in unit reduces noise level
- Filters gas ballast intake air

Ordering Information

Product Description	For Pump	Order No.
151 Series Gas Ballast Silencer/Filter		
# Required		
1	146H, 148H, 149H/S	900151001
1	212J	900151002
2 or 4	412J / 612J	900151002
2	912J	900151003

Min-Max Cooler

The Edwards Model 170-116 mini-max compact cooler provides closed circuit cooling specially designed for mobile pumping systems. It includes pump, radiator, fan, motor (115/60/1), on-off switch, connection kit for the microvac pumps, and has a cooling capacity of 14000 BTU/hr. The mini-max cooler is ideal when cooling water is not convenient or clean enough to ensure peak performance.

Technical Data

For use with Model 149, 212 & 412 Rotary Piston Pumps

Motor	1/4 hp (Pump and Fan)
Motor Voltage	115 V, 1-ph, 60 Hz
	230 V, 1-ph, 60 Hz
Cooling Capacity	14000 BTU/hour
Hose Length	5 feet
Reservoir Tank Capacity	3 gallons
Overall Dimensions	12 1/4" W x 23 1/4" I X 13 1/4" H
Weight	50 lbs

Ordering Information

Product Description	Order No.
Minimax Cooling System	900170116
Includes: Pump, Radiator, Fan, Motors, On-Off Switch, Piping, Wiring and Hoses.	

Oil Mist Separators

The 291 series oil mist separators are high performance air/oil coalescing separators that will virtually eliminate all liquids and solids from a gas stream. These units produce exhaust liquid levels as low as 0.05 PPMW and solids removal in excess of 99.79% efficiency for particulate as small as 0.3 micron.

Features & Benefits

- Clean pump exhaust, saves oil
- Two-stage design removes oil smog and traps particles as small as 0.3 microns
- Standard and heavy models available

Heavy Duty Oil Mist Filter

Heavy-duty oil mist separators are designed to handle the most severe oil exhaust situations from rotary oil sealed mechanical pumps. For true measure of efficiency, it is important to go beyond the weight to consider the actual number of particles collected. The heavy-duty oil mist separators efficiency by weight approaches 100% and total particle collection 97.8%. Edwards guarantees to collect and remove the stated percentage of particles by size, not by weight alone. The HD mist separator will effectively prevent fume emissions unlike existing separators that do not remove the sub micron particles.

Ordering Information

Product Description	For Pump	CFM	Replacement Elements	Order No.
Oil Mist Separators with Fiberglass Element				
291-30S	146H		085021473	900291021
291-50S	148H		085021474	900291022
291-100S	149H		085021475	900291023
291-150S	212H		085052035	900291024
291-150J	212J only		085052263	900291J24
291-300S	412H, 612H		085052036	900291025
291-300J	412J only		085052264	900291J25
291-750S	912J		085021478	900291026
291-750MB	612MB		085021478	900291027
Oil Mist Separator with Polypropylene Element				
291-30SO	146H		085039836	900291031
291-50SO	148H		085039837	900291032
291-100SO	149H		085039838	900291033
291-150SO	212H		085039839	900291034
291-300SO	412H, 612H		085039840	900291035
291-750SO	912J, 612MB		085039841	900291036
Heavy Duty Oil Mist Separators				
291-150HD	212H and smaller	150	085038239	900291048
291-300HD	412H	300	085038125	900291049
291-600HD	612H	600	085038226	900291050
291-1000HD	Combinations	1000	085044934	900291054
291-1500HD	Combinations	1500	085045429	900291055

Oil Reservoir Heater

Edwards model 212 and 412 oil reservoir heaters are recommended for pre-heating oil in the reservoir prior to pump start up at temperatures below 55 °F. Below 1 Torr., it will help maintain the oil at a temperature high enough to prevent condensation of water vapour in the oil when running with full gas ballast. The 212 and 412 oil reservoir heaters consist of an immersion heater to be inserted into the oil reservoir and an over-temperature switch with sensing bulb to control power to the heater. The heater arrangement can be factory or field installed.

Vacuum Break Solenoid

Features & Benefits

- 2-way 240 V 3/8 inch FNPT
- 2-way 110 V 3/8 inch FNPT

Ordering Information

Product description	For pump	Order No.
Vacuum Break Solenoid	All 240 V	085046623
	All 110 V	085046998

Gask-O-Seal

Features & Benefits

- For tight joint seals
- Combination anodised aluminium retainer with Buna-N seals
- Range to 0.0001 microns

Ordering Information

Product Description	Order No.
Gask-O-Seal	
Pipe Size (inch)	
1.5	900318005
2	900318006
3	900318007
4	900318008
6	900318010
8	900318011
10	900318012
12	900318013
14	900318014
16	900318015
18	900318016
20	900318017
24	900318018

Flex Hose

The model 820 high vacuum hose from Edwards is an all-plastic hose with aluminium flanges tough enough for easy handling streamline use. This rugged, reliable hose is suitable for use in a temperature range of -50 °F to 150 °F, tested to 10⁻² Torr absolute pressure

Ordering Information

Product Description	Flange Gasket	Order No.
Series 820 High Vacuum Hose		
Size		
2" x 20' long	08510028	900820220
3" x 20' long	023001141	900820206
4" x 20' long	023001129	900820208

Flex Connectors

Model 315 flexible connectors feature rugged type 321 stainless steel bellows to sharply ease potential alignment and thermal expansion problems, while significantly reducing vibration transmissions from other equipment. They are designed to provide years of trouble-free service.

Features & Benefits

- Free-formed bellows minimise stress concentration
- Solve alignment problems
- Convoluted bellows of AISI 321 stainless steel
- ASA standard carbon steel flanges
- Sizes from 1.5 inch to 24 inch

Ordering Information

Product Description	Order No.
Type Standard: Flexible connector, vacuum service, convoluted, stainless steel bellows, carbon steel pipe flange, 150# ASA – both ends – 63 micro finish, Mass spec tested.	
Pipe Size (inch)	
1-1/2	900315005
2	900315006
3	900315008
4	900315009
6	900315011
8	900315012
10	900315013
12	900315014
Type CE: Flexible connector, vacuum service, convoluted, stainless steel bellows, carbon steel weld band – one end – to fit over ASA pipe for lap weld, carbon steel pipe flange, 150# ASA – one end – 63 micro finish, Mass spec tested.	
Pipe Size (inch)	
1-1/2	900315099
3	900315102
4	900315103
6	900315105
Type PP: Flexible connector, vacuum service, convoluted, stainless steel bellows, carbon steel pipe ends – both ends – for butt welding, Mass spec tested.	
Pipe Size (inch)	
1-1/2	900315069
2	900315070
3	900315072
4	900315073
6	900315075
8	900315076
10	900315077
12	900315078
Type EE: Flexible connector, vacuum service, convoluted, stainless steel bellows, carbon steel weld band – both ends – to fit over ASA pipe for lap weld, Mass spec tested.	
Pipe Size (inch)	
2	900315090
4	900315093
6	900315095
8	900315096
10	900315097
12	900315098
Type CP: Flexible connector, vacuum service, convoluted, stainless steel bellows, carbon steel pipe end – one end – for butt welding, carbon steel pipe flange, 150# ASA – one end – 63 micro finish, Mass spec tested.	
Pipe Size (inch)	
2	900315080
3	900315082
4	900315083
6	900315085
8	900315086
12	900315088

High Volume Inlet Filters

Features & Benefits

- Traps particulates ahead of pump
- Recommended ahead of all vacuum pumps
- Provide protection to pump internals
- Extends the change interval up to 10 times
- Variety of filter elements available
- 146H pump has a 2 inch flange – 333-30A has a 1 inch flange. 333-100A (2 inch flange) can be used as an option
- 1754 and 1755 have 8 inch flange. Customer must supply an adaptor to mate with 10 inch flange on filter
- Polyester replacement element max temp 200 °F, Glastex replacement element 450 °F
- 1700 Series requires 2 replacement elements

Ordering Information

Product Description	For Pump	CFM	Order No.
Intake Pipeline Filters			
333-30A*	146H	30	900333031
333-50A	148H	50	900333032
333-100A	149H	100	900333033
333-165A	212J	165	900333034
333-330A	412J	400	900333035
333-750A	612J, 912J	850	900333036
333-1125A	1721, 1722, 1738	2000	900333037
333-2250A†	1739, 1733, 1754	2800	900333038
Spares			Order No.
Replacement Glastex Elements‡			
333-30A*			085032573
333-50A			085032576
333-100A			085032579
333-165A			085032582
333-330A			085032585
333-750A			085032079
333-1125A			085032588**
333-2250A†			085032591**
Replacement Polyester Elements‡			
333-30A*			085039010
333-50A			085039011
333-100A			085039012
333-165A			085039013
333-330A			085039014
333-750A			085039077
333-1125A			085039015**
333-2250A†			085039016**

* 146H Pump has a 2" Flange, Filter 333-30A has a 1" Flange. Use Filter 333-100A w/2" Flange as an Option.
 † 1754 and 1755 have 8" Flange. Customer must supply an adaptor to mate w/10" Flange on Filter.
 ‡ Replacement Element is Polyester w/Maximum Temp of 200°F, Glastex has a Maximum Temp. of 450°F.
 ** Two Elements Are Required.

Small Volume Inlet Filter

Features & Benefits

- For small volumes and fast pump down cycles
- Effective protection from harmful solid particles of 0.01 inch or larger
- Less expensive than conventional filters

Ordering Information

Product Description	Flange Size	For Pump	Replacement Elements	Order No.
Small Volume Inlet Filters				
332-3	3"	212J	085036701	900332003
332-4	4"	412J	085036702	900332004
332-6	6"	612J-912J	085036703	900332006
332-8	8"	1721-1722	085036704	900332008

Oil Purifiers

Oil purifiers continuously supply clean oil to the vacuum pump to assure peak uptime while prolonging the life of both the oil and the pump. Oil purifiers from Edwards are designed for use with rotary oil sealed pumps used in dirty applications or for corrosive and hazardous gases. These oil purifiers are commonly used in heat creating, annealing, sintering, brazing, nitriding, and metal melting. The Edwards models are available to handle hydrocarbon and inert oils for rotary oil sealed pumps up to 750 ft³min⁻¹ and can filter out solids to 3 microns.

Features & Benefits

- Keep pump fluids cleaner
- Self-contained and portable
- Suitable for mechanical vacuum pumps up to 730 ft³min⁻¹
- Models available for hydrocarbon and inert oils

Ordering Information

Product Description	For Pump	GPM	Elements Required	Order No.
Vacuum Pump Oil Purifiers				
339-015 (115 V, 1-ph, 60 Hz)	146, 148, 149	1.5	1	900339015
339-015 CE (230 V, 1-ph, 50 Hz)	146, 148, 149	1.2	1	900339015501
339-015 CE (200/400 V, 3-ph, 50 Hz)	146, 148, 149	1.2	1	900339015502
339-030 (115 V, 1-ph, 60 Hz)	212, 412	3	1	900339030
339-030 CE (230 V, 1-ph, 50 Hz)	212, 412	2.3	1	900339030501
339-030 CE (200/400 V, 3-ph, 50 Hz)	212, 412	2.3	1	900339030502
339-150	All	1.5	2	900339150
339-215	All	1.5	2	900339215
339-070	912	7	2	900339070
Special Service (all pumps)				
339-15 (115 V, 1-ph, 60 Hz)*	146, 148, 149	1.5	1	900339151
339-152 (115 V, 1-ph, 60 Hz)†	146-412	1.5	2	900339152
339-251 (115 V, 1-ph, 60 Hz)*	146-412	1.5	2	900339251
339-252 (115 V, 1-ph, 60 Hz)†	146-412	1.5	4	900339252
Spares				Order No.
Model 339 Replacement Oil Purifier Elements				
Standard 339 Filter Fullers Earth 10 microns				085033395
Standard 339 Filter Pleated Paper 3 microns				085039432
Standard 339 Filter Activated Alumna				085039890
Special Service 339 Fullers Earth 10 microns				N/A (use 3 Microns Option)
Special Service 339 Pleated Paper 3 microns				085037794
Special Service 339 Activated Alumna				085039956

* Single element canister
 † Double element canister

MB/MV Series Vertically Oriented Booster Combinations

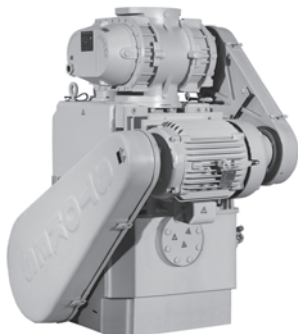

Overview

Edwards multi-stage pumping systems, backed by over a century of in-depth applications knowledge and technical experience.

These compact, efficient pumping systems feature a Stokes microvac pump and rugged, proven Stokes 6" Series boosters or the Edwards EH series with patented hydrokinetic drive. MB series configurations are comprised of the Stokes 412J piston pumps coupled with a model 607 mechanical booster. The configuration has the ability to start at atmospheric pressure without the need for a pressure switch, packages are offered as a cost-effective alternative for low to medium range capacity requirement.

The MV Series Mechanical Booster Pump Packages comprises of either the Stokes 212J or 412J rotary piston pump. Each can be directly coupled with a range of mechanical booster pumps. The range includes Edwards EH series offering the patented Hydrokinetic Drive or the full range of Stokes 6" series. All are vertical gas flow orientation for a compact space saving design. The MV Series offers a broad selection of configurations which enables the flexibility to mix and match the complete range of Stokes Microvac accessories along with various electrical control options. This enables the user to customize the pumping package to meet their application requirements.

1700 Series High Capacity Mechanical Booster Pump Combinations



Overview

Whether you need to increase the capacity of your existing system or achieve peak performance for a new installation; Edwards makes taking advantage of the latest technology easy. These field-proven pumping systems are the workhorse of countless industrial and large chamber applications. Each Stokes 1700 series mechanical booster combinations includes a Stokes microvac backing pump and a belt driven, Stoke 6" series mechanical booster pump horizontal flow. In harsh applications where chemical or particulate contamination is present, process isolation boosters are available as an option. Controls for Stokes 1700 series mechanical booster combinations include a pressure switch, motor starters, fuses and overload.

The Stokes 1700 series combinations deliver the high capacity needed to achieve faster pump-downs. Most importantly, these systems achieve the task more cost effectively than larger single stage pumps. Depending on the specific application, they can improve blank-off by a factor of ten over large, single stage pumps. Pumping capacities range from 1300 to 7880 ft³min⁻¹.

Stokes 412MBX Multi-Stage Pumping System



Stokes MB Multi-stage pumping systems are available in two options, consisting of a Microvac piston pump and a Stokes 607 mechanical booster pump. The compact direct mounted packages provide high performance pumping from atmosphere. The MB systems are ideal for high cycling arduous applications.

Dimensions

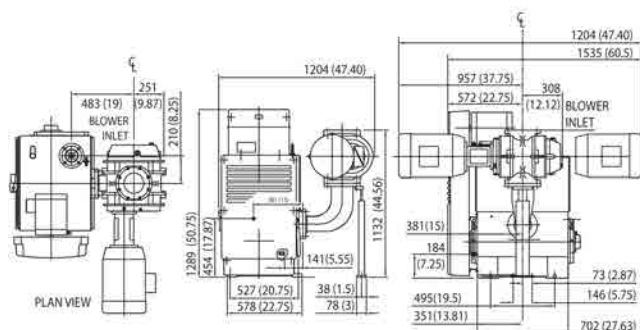

Performance Curves

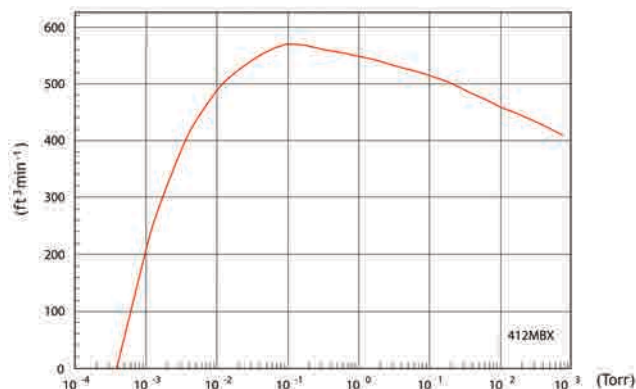

8

Page
316

Technical Data

Blower displacement (swept volume) (AVS)	1040 m ³ h ⁻¹ / 612 ft ³ min ⁻¹
Pump displacement (swept volume) (AVS)	510 m ³ h ⁻¹ / 300 ft ³ min ⁻¹
Blower motor size	15 kW / 20 hp
Microvac motor size	7.5 kW / 10 hp
Blower motor	1800 rpm
Microvac motor	1800 rpm
Inlet connection	6 inch ASA/ANSI flange
Exhaust connection	3 inch ASA/ANSI flange or 3 inch NPT
Microvac water inlet/outlet connection	½ inch NPT
Recommended cooling flow @ 30 °C/85 °F	7.6 lmin ⁻¹ / 1 US galmin ⁻¹
Booster oil capacity	4.2 litre / 22 US gal
Microvac oil capacity	46 litre / 12 US gal
Booster recommended oil	V lube H
Microvac recommended oil	V lube F
Dimensions (L x W x H)	973 x 1022 x 1365 mm 47 x 55.69 x 51.75 inch
Height to inlet	868 mm / 34.19 inch
Weight	1202 kg / 2650 lbs

Ordering Information

Product Description	Order No.
412MBX Multi-stage Pumping System 230/460V, 3Ø, 60 Hz with 230/460V Coil	900412072
Accessories & Spares	Order No.
Replacement parts kit	429638015
Bearings	085019757
Valve deck assembly	607417001
Replacement 6" booster Mseal - seal kit	607552001
Replacement 6" booster - maintenance kit	607552002
Replacement parts kit for 412H pump	429638012

Stokes 612MB Multi-Stage Pumping System

Stokes MB Multi-stage pumping systems are available in two options, consisting of a Microvac piston pump and a Stokes 607 mechanical booster pump. The compact direct mounted packages provide high performance pumping from atmosphere. The MB systems are ideal for high cycling arduous applications. The 612MB Multi-stage pumping systems incorporate an integral bypass valve which offers increased speed at atmospheric pressure.



Dimensions

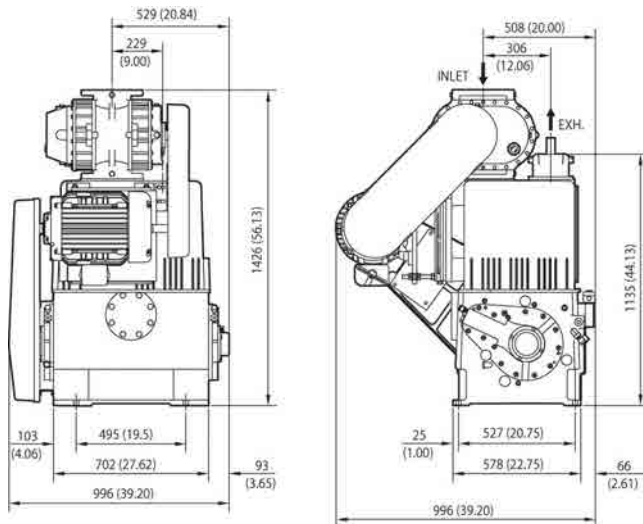

Performance Curves

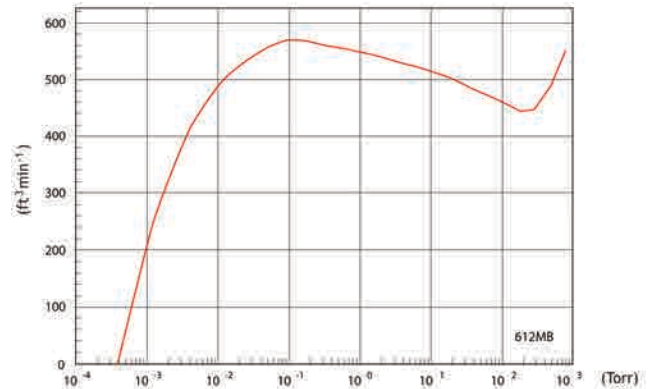

Technical Data

Blower displacement (swept volume) (AVS)	1040 m ³ h ⁻¹ / 612 ft ³ min ⁻¹
Pump displacement (swept volume) (AVS)	510 m ³ h ⁻¹ / 300 ft ³ min ⁻¹
Pressure switch required	No
Blower motor size ***	15 kW / 20 hp
Motor	1800 rpm
Inlet connection	6 inch ASA/ANSI flange
Exhaust connection	4 inch NPT
Microvac water inlet/outlet connection	½ inch NPT
Recommended cooling flow @ 30 °C/85 °F	7.6 lmin ⁻¹ / 2 US galmin ⁻¹
Booster oil capacity	4.7 litre / 7 US gal
Microvac oil capacity	46 litre / 12 US gal
Booster recommended oil	V lube H
Microvac recommended oil	V lube F
Dimensions (L x W x H)	1181 x 1022 x 1434 mm 47 x 55.69 x 51.75 inch
Height to inlet	1434 mm / 56.44 inch
Weight	1452 kg / 3200 lbs

*** 612 MB incorporates double shafted single motor

Ordering Information

Product Description	Order No.
612MBX Multi-stage Pumping System 230/460V, 3Ø, 60 Hz with 230/460V Coil	900612J30
Accessories & Spares	Order No.
Replacement parts kit	429638015
Bearings	085019757
Valve deck assembly	607417001
Replacement 6" booster Mseal - seal kit	607552001
Replacement 6" booster - maintenance kit	607552002

MV Series Oil Sealed Piston Pumps and Mechanical Booster Combinations

Ordering Information

CE Marking

0 No CE mark required
1 CE marked system

Microvac Pump

1 212J
2 412J
3 212J with base
4 412J with base

Booster

0 No booster
1 EH250
2 EH500
3 EH1200
4 EH2600
5 EH4200
6 EH250 with 3 inch ASA inlet
7 EH500 with 4 inch ASA inlet
8 EH1200 with 6 inch ASA inlet
9 EH2600 with 8 inch ASA inlet
A 607MV05
B 607MV20
C 615MV10
D 615MV15
E 61BMV10
F 61BMV25
M 622MV25

Oil Mist Filter

0 No mist filter
1 MF 291-150J
2 MF 291-300J

Cooling Options

0 No cooling options
1 Water miser
2 Min max cooler 115 V 1-ph 60 Hz
3 Min max cooler 230 V 1-ph 60 Hz

Oil Purification and Connection Kit

0 No oil purifier
1 OP 339-030 115 V 1-ph 60 Hz
2 OP 339-030CE 230 V 1-ph 50 Hz
3 OP 339-030CE 230/400 V 1-ph 50 Hz
4 OP 339-215 115 V 1-ph 60 Hz

Manual Selection

0 English
1 French
2 German
3 Italian
4 Chinese
5 Japanese
6 Korean
7 Spanish
8 Dutch
9 Other EU
A Other European
B Other Asian

Motor Control Module

0 No motor control/pressure switch
1 Motor starter control box pedestal mount without pressure switch****
2 Motor starter control box wall mount without pressure switch****
3 Motor starter control box pedestal mount with pressure switch****
4 Pressure switch only
5 Motor starter control box wall mount with pressure switch****

Coil Voltage

1 24 V a.c. 50 Hz
2 24 V a.c. 60 Hz
3 120 V 60 Hz/110 V 50 Hz
4 240 V 60 Hz/220 V 50 Hz
5 380 V 50 Hz
6 415 V 50 Hz
7 480 V 60 Hz/440 V 50 Hz
8 380 V 60 Hz

Motor Voltage (All TEFC Motors)

1 230 V 3-ph 60 Hz
2 460 V 3-ph 60 Hz
3 400 V 3-ph 50 Hz CE
4 220 V 3-ph 50 Hz
5 380 V 3-ph 50 Hz
6 440 V 3-ph 50 Hz
7 380 V 3-ph 60 Hz

Gas Ballast Silencer and Vacuum Break

0 No gas ballast, no silencer, no vacuum break
1 Gas ballast silencer
2 Auto gas ballast 24 V a.c. 60 Hz
3 Auto gas ballast 24 V d.c. din
4 Auto gas ballast 120 V 60 Hz/110 V 50 Hz

MV

--	--	--	--	--	--	--	--	--	--	--	--	--	--	--	--	--	--	--	--

Note* Above booster combinations are direct mount vertical flow.
 Note** Oil mist filters and min max coolers will ship separately unless ordered with base frame.
 Note*** Oxygen service pumps are available, please contact your local Edwards representative to discuss your requirements.
 Note**** Not applicable in CE versions.
 For other possible combinations, please contact your local Edwards representative to discuss your requirements.

Stokes 1721 Mechanical Booster Pump Combination

Whether you need to increase the capacity of your existing system or achieve peak performance for a new installation; Edwards makes taking advantage of the latest technology easy. These field-proven pumping systems are the workhorse of countless industrial and large chamber applications. Each Stokes1700 series mechanical booster pump combination includes a Stokes Microvac backing pump and a belt driven, horizontal flow, high vacuum Stokes 6" series mechanical booster pump. In harsh applications where chemical or particulate contamination is present, process isolation boosters are available as an option. Controls for Stokes 1700 series mechanical booster pump combination include a pressure switch, motor starters, overloads, remote booster selection switch and lights for pump running and fault indication.



Dimensions

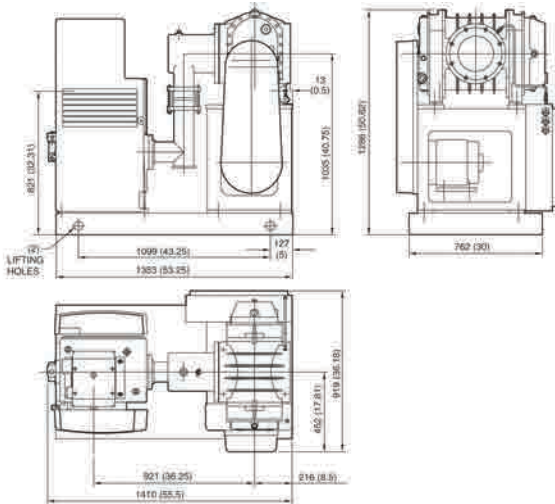

Performance Curves

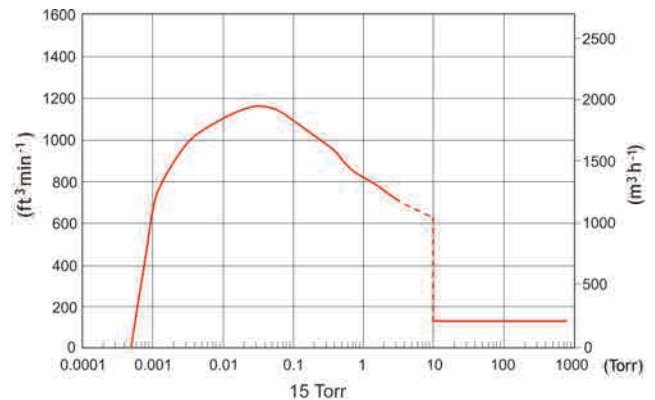

Technical Data

Booster displacement	2210 m ³ h ⁻¹ / 1300 ft ³ min ⁻¹
Booster speed	1800 rpm
Booster orientation	Horizontal
Pump displacement	255 m ³ h ⁻¹ / 150 ft ³ min ⁻¹
Pressure switch required	Yes
Normal cut-in pressure	20 mbar / 10 Torr
Continuous operation pressure limit	4 mbar / 3 Torr
Booster drive	5.6 kW / 7.5 hp
Pump drive (TEFC)	5.6 kW / 7.5 hp
Inlet connections	8 inch ASA/ANSI flange
Discharge connections	2 inch ASA/ANSI flange, 2 inch NPT
Water inlet/outlet connection	½ inch NPT
Recommended cooling flow @ 30°C/85 °F	5.7 lmin ⁻¹ / 1.5 galmin ⁻¹
Booster oil capacity (V lube H)	1.9 litre / 0.51 US gal
Microvac oil capacity (V lube F)	15 litre / 4 US gal
Inlet height	1035 mm / 40.75 inch
Footprint (L x W x H)	1419 x 919 x 1260 mm 55.87 x 36.18 x 49.61 inch
Weight	1225 kg / 2700 lbs

Ordering Information

Product Description	Order No.
1721 230/460V, 3-ph, 60Hz (230/460V Coil)	900170061
Accessories & Spares	Order No.
Replacement parts kit	429638016
Bearings	085019757
Valve deck assembly	607417001
Replacement 6" booster Mseal - seal kit	607552001
Replacement 6" booster - maintenance kit	607552002

Stokes 1721S Mechanical Booster Pump Combination



Whether you need to increase the capacity of your existing system or achieve peak performance for a new installation; Edwards makes taking advantage of the latest technology easy. These field-proven pumping systems are the workhorse of countless industrial and large chamber applications. Each Stokes1700 series mechanical booster pump combination includes a Stokes Microvac backing pump and a belt driven, horizontal flow, high vacuum Stokes 6" series mechanical booster pump. In harsh applications where chemical or particulate contamination is present, process isolation boosters are available as an option. Controls for Stokes 1700 series mechanical booster pump combination include a pressure switch, motor starters, overloads, remote booster selection switch and lights for pump running and fault indication.

Dimensions

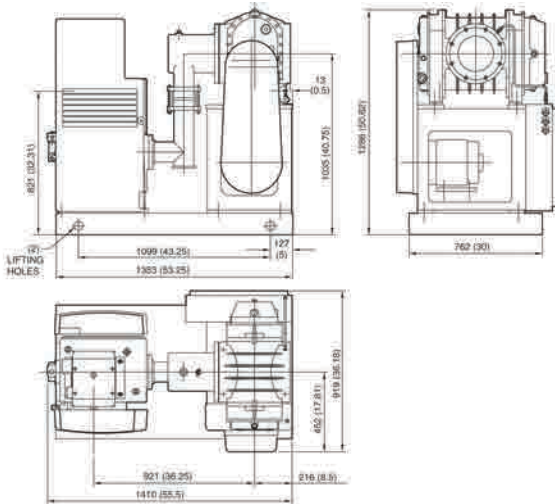

Performance Curves

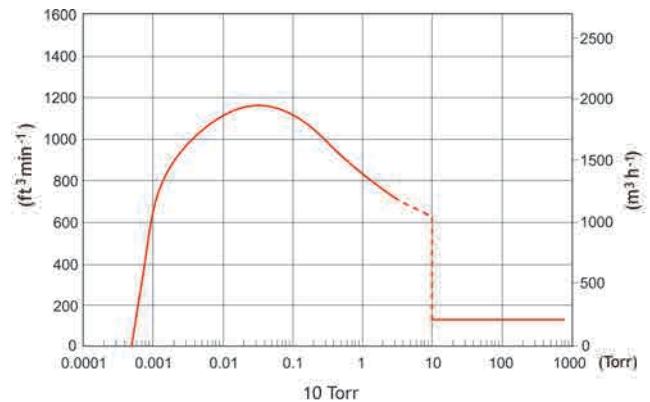

Technical Data

Booster displacement	2720 m ³ h ⁻¹ / 1600 ft ³ min ⁻¹
Booster speed	2200 rpm
Booster orientation	Horizontal
Pump displacement	255 m ³ h ⁻¹ / 150 ft ³ min ⁻¹
Pressure switch required	Yes
Normal cut-in pressure	13 mbar / 10 Torr
Continuous operation pressure limit	2.6 mbar / 2 Torr
Booster drive	7.5 kW / 10 hp
Pump drive (TEFC)	6.5 kW / 7.5 hp
Inlet connections	8 inch ASA/ANSI flange
Discharge connections	2 inch ASA/ANSI flange, 2 inch NPT
Water inlet/outlet connection	½ inch NPT
Recommended cooling flow @ 30°C/85 °F	5.7 lmin ⁻¹ / 1.5 galmin ⁻¹
Booster oil capacity (V lube H)	1.9 litre / 0.51 US gal
Microvac oil capacity (V lube F)	15 litre / 4 US gal
Inlet height	1035 mm / 40.75 inch
Footprint (L x W x H)	1419 x 919 x 1260 mm 55.87 x 36.18 x 49.61 inch
Weight	1270 kg / 2800 lbs

Ordering Information

Product Description	Order No.
1721S 230/460V, 3-ph, 60Hz (230/460V Coil)	900170074
Accessories & Spares	Order No.
Replacement parts kit	429638016
Bearings	085019757
Valve deck assembly	607417001
Replacement 6" booster Mseal - seal kit	607552001
Replacement 6" booster - maintenance kit	607552002

Stokes 1722 Mechanical Booster Pump Combination

Whether you need to increase the capacity of your existing system or achieve peak performance for a new installation; Edwards makes taking advantage of the latest technology easy. These field-proven pumping systems are the workhorse of countless industrial and large chamber applications. Each Stokes1700 series mechanical booster pump combination includes a Stokes Microvac backing pump and a belt driven, horizontal flow, high vacuum Stokes 6" series mechanical booster pump. In harsh applications where chemical or particulate contamination is present, process isolation boosters are available as an option. Controls for Stokes 1700 series mechanical booster pump combination include a pressure switch, motor starters, overloads, remote booster selection switch and lights for pump running and fault indication.



Dimensions

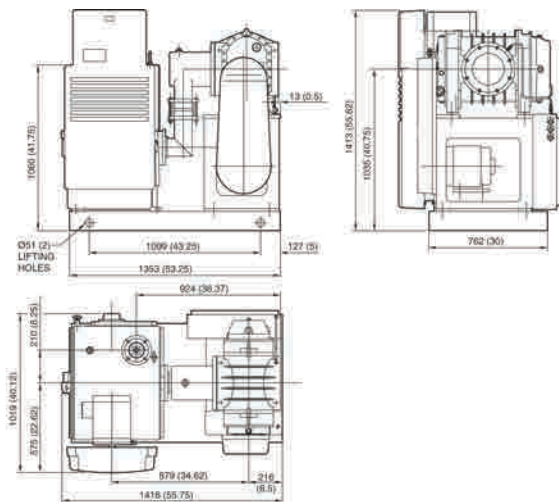

Performance Curves

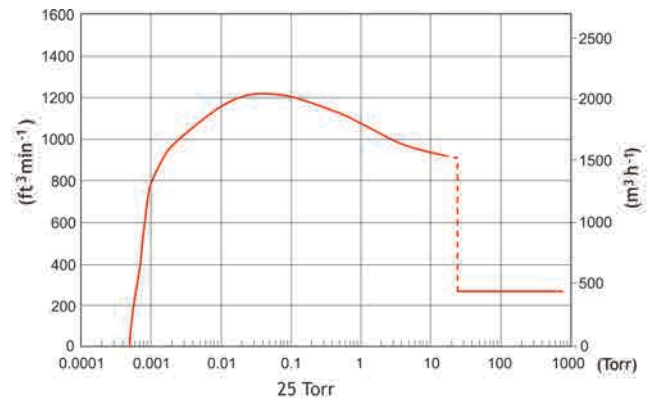

Technical Data

Booster displacement	2210 m ³ h ⁻¹ / 1300 ft ³ min ⁻¹
Booster speed	1800 rpm
Booster orientation	Horizontal
Pump displacement	510 m ³ h ⁻¹ / 300 ft ³ min ⁻¹
Pressure switch required	Yes
Normal cut-in pressure	33 mbar / 25 Torr
Continuous operation pressure limit	20 mbar / 15 Torr
Booster drive	5.6 kW / 7.5 hp
Pump drive (TEFC)	7.5 kW / 10 hp
Inlet connections	8 inch ASA/ANSI flange
Discharge connections	3 inch ASA/ANSI flange, 3 inch NPT
Water inlet/outlet connection	½ inch NPT
Recommended cooling flow @ 30°C/85 °F	7.6 lmin ⁻¹ / 2 galmin ⁻¹
Booster oil capacity (V lube H)	1.9 litre / 0.51 US gal
Microvac oil capacity (V lube F)	46 litre / 12 US gal
Inlet height	1035 mm / 40.75 inch
Footprint (L x W x H)	1407 x 1048 x 1438 mm 55.40 x 41.26 x 56.61 inch
Weight	1588 kg / 3500 lbs

Ordering Information

Product Description	Order No.
1722 230/460V, 3-ph, 60Hz (230/460V Coil)	900170062
Accessories & Spares	Order No.
Replacement parts kit	429638015
Bearings	085019757
Valve deck assembly	607417001
Replacement 6" booster Mseal - seal kit	607552001
Replacement 6" booster - maintenance kit	607552002

Stokes 1722S Mechanical Booster Pump Combination



Whether you need to increase the capacity of your existing system or achieve peak performance for a new installation; Edwards makes taking advantage of the latest technology easy. These field-proven pumping systems are the workhorse of countless industrial and large chamber applications. Each Stokes 1700 series mechanical booster pump combination includes a Stokes Microvac backing pump and a belt driven, horizontal flow, high vacuum Stokes 6" series mechanical booster pump. In harsh applications where chemical or particulate contamination is present, process isolation boosters are available as an option. Controls for Stokes 1700 series mechanical booster pump combination include a pressure switch, motor starters, overloads, remote booster selection switch and lights for pump running and fault indication.

Dimensions

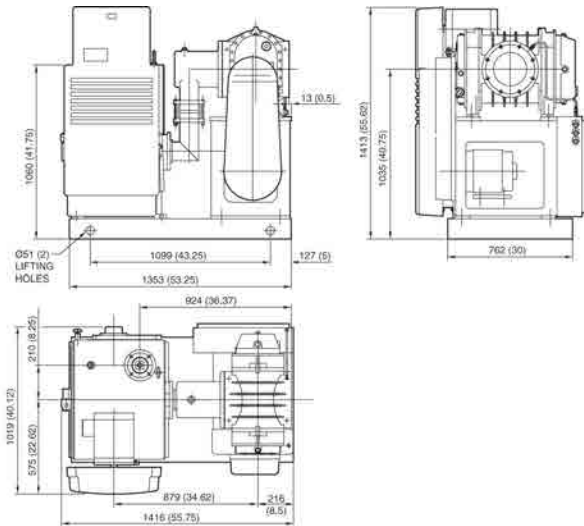

Performance Curves

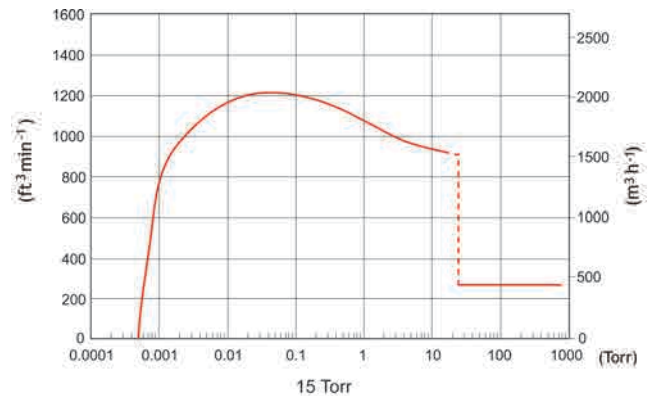

Technical Data

Booster displacement	2720m ³ h ⁻¹ / 1600 ft ³ min ⁻¹
Booster speed	2200 rpm
Booster orientation	Horizontal
Pump displacement	510 m ³ h ⁻¹ / 300 ft ³ min ⁻¹
Pressure switch required	Yes
Normal cut-in pressure	20 mbar / 15 Torr
Continuous operation pressure limit	10.7 mbar / 8 Torr
Booster drive	7.5 kW / 10 hp
Pump drive (TEFC)	7.5 kW / 10 hp
Inlet connections	8 inch ASA/ANSI flange
Discharge connections	3 inch ASA/ANSI flange, 3 inch NPT
Water inlet/outlet connection	½ inch NPT
Recommended cooling flow @ 30°C/85°F	7.6 lmin ⁻¹ / 2 galmin ⁻¹
Booster oil capacity (V lube H)	1.9 liter / 0.51 US gal
Microvac oil capacity (V lube F)	46 liter / 12 US gal
Inlet height	1035 mm / 40.75 inch
Footprint (L x W x H)	1407 x 1048 x 1438 mm
	55.40 x 41.26 x 56.61 inch
Weight	1633 kg / 3600 lbs

Ordering Information

Product Description	Order No.
1722S 230/460V, 3-ph, 60Hz (230/460V Coil)	900170075
Accessories & Spares	Order No.
Replacement parts kit	429638015
Bearings	085019757
Valve deck assembly	607417001
Replacement 6" booster Mseal - seal kit	607552001
Replacement 6" booster - maintenance kit	607552002

Stokes 1733 Mechanical Booster Pump Combination

Whether you need to increase the capacity of your existing system or achieve peak performance for a new installation; Edwards makes taking advantage of the latest technology easy. These field-proven pumping systems are the workhorse of countless industrial and large chamber applications. Each Stokes1700 series mechanical booster pump combination includes a Stokes Microvac backing pump and a belt driven, horizontal flow, high vacuum Stokes 6" series mechanical booster pump. In harsh applications where chemical or particulate contamination is present, process isolation boosters are available as an option. Controls for Stokes 1700 series mechanical booster pump combination include a pressure switch, motor starters, overloads, remote booster selection switch and lights for pump running and fault indication.



Dimensions

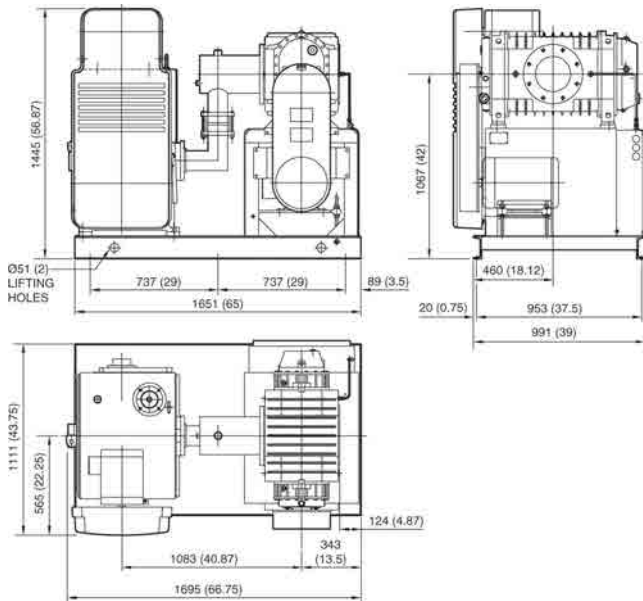

Performance Curves

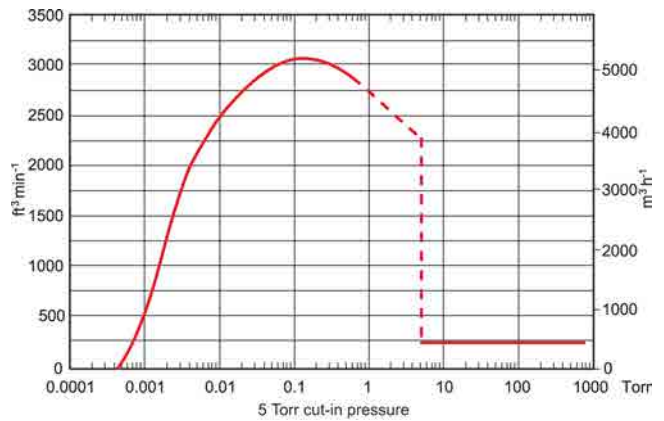

Technical Data

Booster displacement	6538 m ³ h ⁻¹ / 3840 ft ³ min ⁻¹
Booster speed	3600 rpm
Booster orientation	Horizontal
Pump displacement	510 m ³ h ⁻¹ / 300 ft ³ min ⁻¹
Pressure switch required	Yes
Normal cut-in pressure	6.7 mbar / 5 Torr
Continuous operation pressure limit	0.8 mbar / 0.6 Torr
Booster drive	18.5 kW / 25 hp
Pump drive	7.5 kW / 10 hp
Inlet connections	8 inch ASA/ANSI flange
Discharge connections	3 inch ASA/ANSI flange, 3 inch NPT
Water inlet connection	½ inch NPT (2)
Water outlet connection	½ inch NPT
Recommended cooling flow @ 30°C/85 °F	7.6 l min ⁻¹ / 2 gal min ⁻¹
Booster oil capacity (V lube H)	1.9 litre / 0.51 US gal
Microvac oil capacity (V lube F)	46 litre / 12 US gal
Weight	1710 kg / 3770 lbs

Ordering Information

Product Description	Order No.
1733 230/460V, 3-ph, 60Hz (230/460V Coil)	900170S33
Accessories & Spares	Order No.
Replacement parts kit	429638015
Bearings	085019757
Valve deck assembly	607417001
Replacement 6" booster Mseal - seal kit	607552001
Replacement 6" booster - maintenance kit	607552002

Stokes 1733HC Mechanical Booster Pump Combination



Whether you need to increase the capacity of your existing system or achieve peak performance for a new installation; Edwards makes taking advantage of the latest technology easy. These field-proven pumping systems are the workhorse of countless industrial and large chamber applications. Each Stokes 1700 series mechanical booster pump combination includes a Stokes Microvac backing pump and a belt driven, horizontal flow, high vacuum Stokes 6" series mechanical booster pump. In harsh applications where chemical or particulate contamination is present, process isolation boosters are available as an option. Controls for Stokes 1700 series mechanical booster pump combination include a pressure switch, motor starters, overloads, remote booster selection switch and lights for pump running and fault indication.

Dimensions

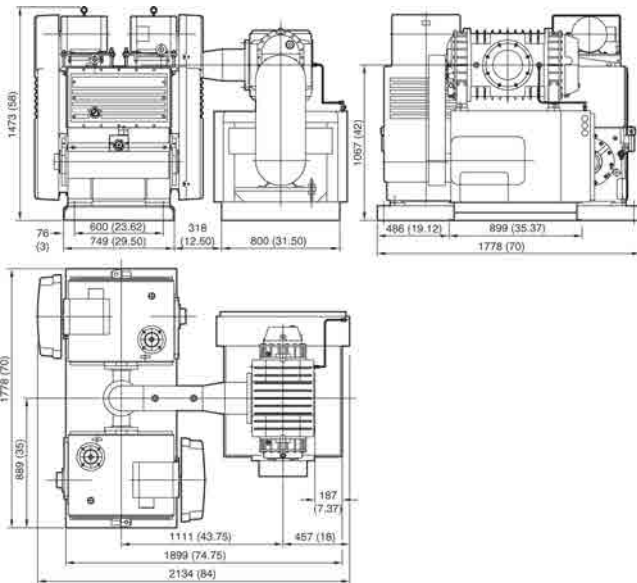

Performance Curves

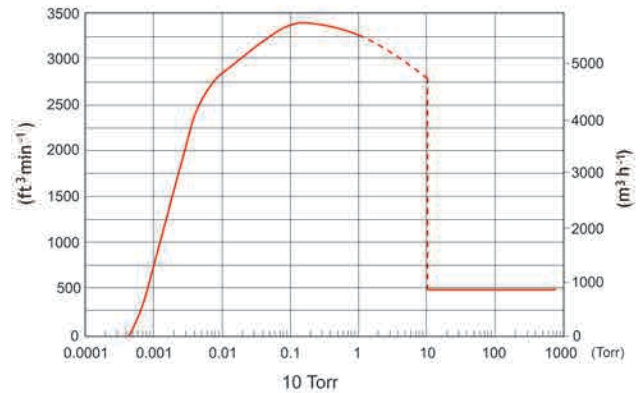

Technical Data

Booster displacement	6538 m ³ h ⁻¹ / 3840 ft ³ min ⁻¹
Booster speed	3600 rpm
Booster orientation	Horizontal
Pump displacement	1020 m ³ h ⁻¹ / 600 ft ³ min ⁻¹
Pressure switch required	Yes
Normal cut-in pressure	13.3 mbar / 10 Torr
Continuous operation pressure limit	1.3 mbar / 1 Torr
Booster drive	22.5 kW / 30 hp
Pump drive	7.5 kW (x2) / 10 hp (x2)
Inlet connections	8 inch ASA/ANSI flange
Discharge connections	3 inch ASA/ANSI flange, 3 inch NPT (x2)
Water inlet/outlet connection	½ inch NPT (x2)
Recommended cooling flow @ 30°C/85°F	7.6 l min ⁻¹ (x2) / 2 gal min ⁻¹ (x2)
Booster oil capacity (V lube H)	1.9 litre / 0.51 US gal
Microvac oil capacity (V lube F)	92 litre / 24 US gal
Weight	2767 kg / 6100 lbs

Ordering Information

Product Description	Order No.
1733HC 230/460V, 3-ph, 60Hz (230/460V Coil)	900170S34
Accessories & Spares	Order No.
Replacement parts kit	429638015
Bearings	085019757
Valve deck assembly	607417001
Replacement 6" booster Mseal - seal kit	607552001
Replacement 6" booster - maintenance kit	607552002

Stokes 1733HD Mechanical Booster Pump Combination

Whether you need to increase the capacity of your existing system or achieve peak performance for a new installation; Edwards makes taking advantage of the latest technology easy. These field-proven pumping systems are the workhorse of countless industrial and large chamber applications. Each Stokes1700 series mechanical booster pump combination includes a Stokes Microvac backing pump and a belt driven, horizontal flow, high vacuum Stokes 6" series mechanical booster pump. In harsh applications where chemical or particulate contamination is present, process isolation boosters are available as an option. Controls for Stokes 1700 series mechanical booster pump combination include a pressure switch, motor starters, overloads, remote booster selection switch and lights for pump running and fault indication.



Dimensions

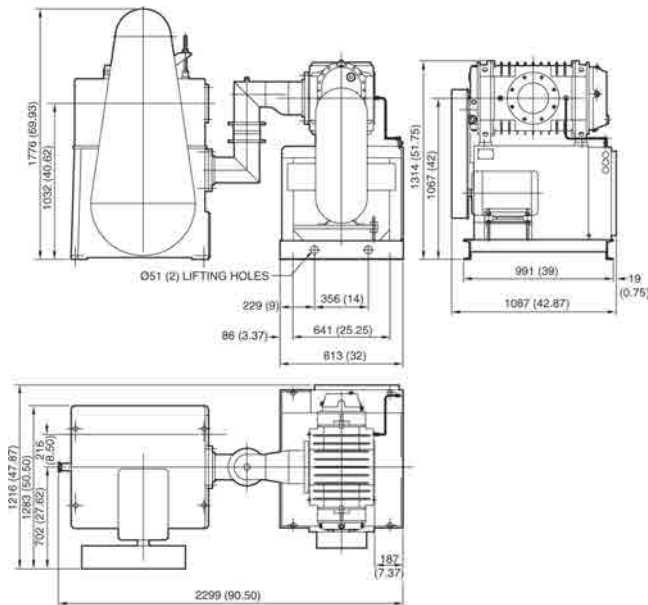

Performance Curves

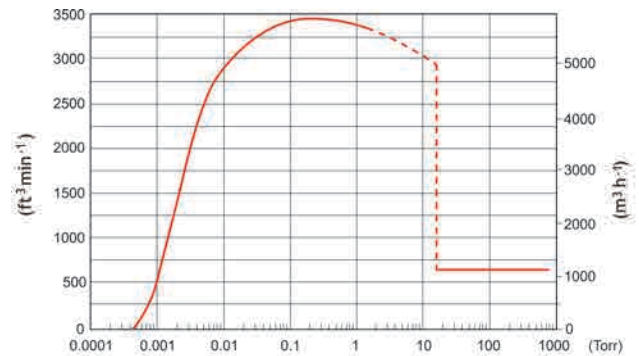

Technical Data

Booster displacement	6538 m ³ h ⁻¹ / 3840 ft ³ min ⁻¹
Booster speed	3600 rpm
Booster orientation	Horizontal
Pump displacement	1240 m ³ h ⁻¹ / 730 ft ³ min ⁻¹
Pressure switch required	Yes
Normal cut-in pressure	20 mbar / 15 Torr
Continuous operation pressure limit	2 mbar / 1.5 Torr
Booster drive	22.5 kW / 30 hp
Pump drive	22.5 kW / 30 hp
Inlet connections	8 inch ASA/ANSI flange
Discharge connections	3 inch NPT
Water inlet/outlet connection	1 inch NPT
Recommended cooling flow @ 30°C/85 °F	18.9 lmin ⁻¹ / 5 galmin ⁻¹
Booster oil capacity (V lube H)	1.9 litre / 0.51 US gal
Microvac oil capacity (V lube F)	76 litre / 20 US gal
Weight	3538 kg / 7800 lbs

Ordering Information

Product Description	Order No.
1733HD 230/460V, 3-ph, 60Hz (230/460V Coil)	900170S35
Accessories & Spares	Order No.
Replacement 6" booster Mseal - seal kit	607552001
Replacement 6" booster - maintenance kit	607552002
Replacement oil seal	085018191
Replacement roller bearing	085033795
Roller bearing with adaptive sleeve	085033794
Valve deck stainless steel clappers	272963002
Valve deck springs	274172001

Stokes 1738 Mechanical Booster Pump Combination



Whether you need to increase the capacity of your existing system or achieve peak performance for a new installation; Edwards makes taking advantage of the latest technology easy. These field-proven pumping systems are the workhorse of countless industrial and large chamber applications. Each Stokes1700 series mechanical booster pump combination includes a Stokes Microvac backing pump and a belt driven, horizontal flow, high vacuum Stokes 6" series mechanical booster pump. In harsh applications where chemical or particulate contamination is present, process isolation boosters are available as an option. Controls for Stokes 1700 series mechanical booster pump combination include a pressure switch, motor starters, overloads, remote booster selection switch and lights for pump running and fault indication.

Dimensions

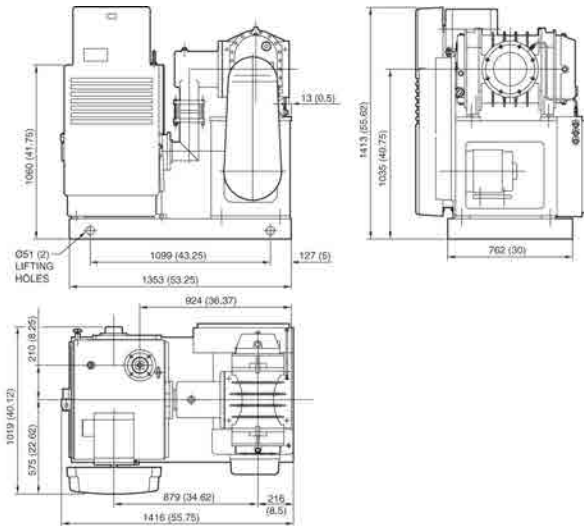

Performance Curves

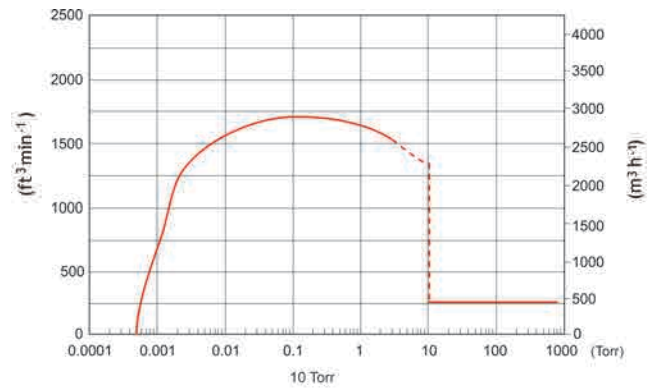

Technical Data

Booster displacement	3398 m ³ h ⁻¹ / 2000 ft ³ min ⁻¹
Booster speed	2750 rpm
Booster orientation	Horizontal
Pump displacement	510 m ³ h ⁻¹ / 300 ft ³ min ⁻¹
Pressure switch required	Yes
Normal cut-in pressure	13 mbar / 10 Torr
Continuous operation pressure limit	4 mbar / 3 Torr
Booster drive	7.5 kW / 10 hp
Pump drive (TEFC)	7.5 kW / 10 hp
Inlet connections	8 inch ASA/ANSI flange
Discharge connections	3 inch ASA/ANSI flange, 3 inch NPT
Water inlet/outlet connection	½ inch NPT
Recommended cooling flow @ 30°C/85 °F	7.6 lmin ⁻¹ / 2 galmin ⁻¹
Booster oil capacity (V lube H)	1.9 litre / 0.51 US gal
Microvac oil capacity (V lube F)	46 litre / 12 US gal
Inlet height	1035 mm / 40.75 inch
Footprint (L x W x H)	1407 x 1048 x 1438 mm
	55.40 x 41.26 x 56.61 inch
Weight	1633 kg / 3600 lbs

Ordering Information

Product Description	Order No.
1738 230/460V, 3-ph, 60Hz (230/460V Coil)	900170038
Accessories & Spares	Order No.
Replacement parts kit	429638015
Bearings	085019757
Valve deck assembly	607417001
Replacement 6" booster Mseal - seal kit	607552001
Replacement 6" booster - maintenance kit	607552002

Stokes 1738BP Mechanical Booster Pump Combination

Whether you need to increase the capacity of your existing system or achieve peak performance for a new installation; Edwards makes taking advantage of the latest technology easy. These field-proven pumping systems are the workhorse of countless industrial and large chamber applications. Each Stokes1700 series mechanical booster pump combination includes a Stokes Microvac backing pump and a belt driven, horizontal flow, high vacuum Stokes 6" series mechanical booster pump. In harsh applications where chemical or particulate contamination is present, process isolation boosters are available as an option. Controls for Stokes 1700 series mechanical booster pump combination include a pressure switch, motor starters, overloads, remote booster selection switch and lights for pump running and fault indication.



Dimensions

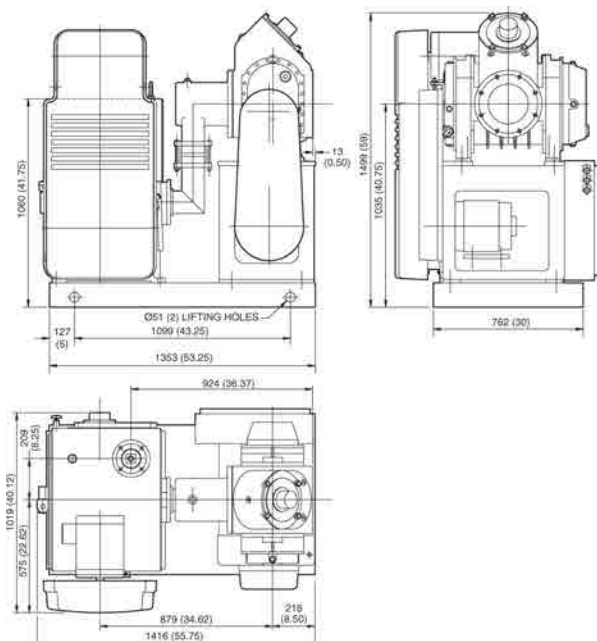

Performance Curves

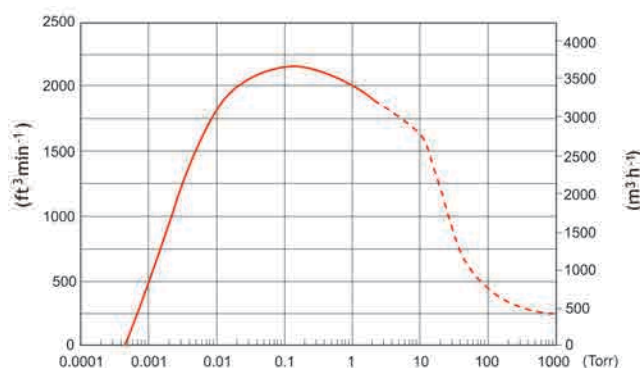

Technical Data

Booster displacement	3398 m ³ h ⁻¹ / 2000 ft ³ min ⁻¹
Booster speed	2750 rpm
Booster orientation	Horizontal
Pump displacement	510 m ³ h ⁻¹ / 300 ft ³ min ⁻¹
Pressure switch required	No
Continuous operation pressure limit	4 mbar / 3 Torr
Booster drive	11 kW / 15 hp
Pump drive (TEFC)	7.5 kW / 10 hp
Inlet connections	8 inch ASA/ANSI flange
Discharge connections	3 inch ASA/ANSI flange, 3 inch NPT
Water inlet/outlet connection	½ inch NPT
Recommended cooling flow @ 30°C/85 °F	7.6 lmin ⁻¹ / 2 galmin ⁻¹
Booster oil capacity (V lube H)	1.9 litre / 0.51 US gal
Microvac oil capacity (V lube F)	46 litre / 12 US gal
Weight	1690 kg / 3725 lbs

Ordering Information

Product Description	Order No.
1738BP 230/460V, 3-ph, 60Hz (230/460V Coil)	90017038B
Accessories & Spares	Order No.
Replacement parts kit	429638015
Bearings	085019757
Valve deck assembly	607417001
Replacement 6" booster Mseal - seal kit	607552001
Replacement 6" booster - maintenance kit	607552002

Stokes 1738HC Mechanical Booster Pump Combination



Whether you need to increase the capacity of your existing system or achieve peak performance for a new installation; Edwards makes taking advantage of the latest technology easy. These field-proven pumping systems are the workhorse of countless industrial and large chamber applications. Each Stokes1700 series mechanical booster pump combination includes a Stokes Microvac backing pump and a belt driven, horizontal flow, high vacuum Stokes 6" series mechanical booster pump. In harsh applications where chemical or particulate contamination is present, process isolation boosters are available as an option. Controls for Stokes 1700 series mechanical booster pump combination include a pressure switch, motor starters, overloads, remote booster selection switch and lights for pump running and fault indication.

Dimensions

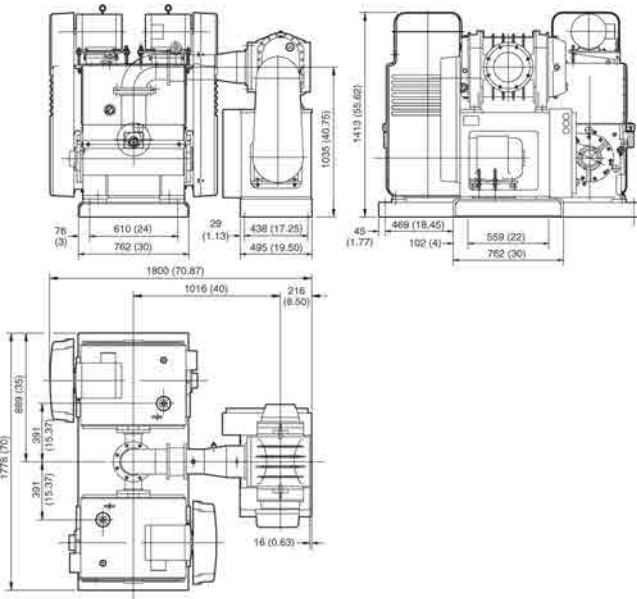

Performance Curves

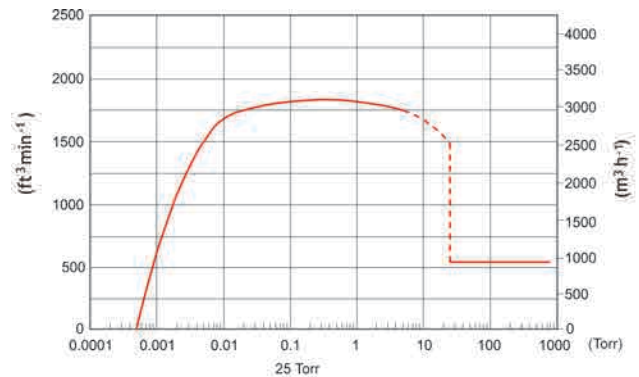

Technical Data

Booster displacement	3398 m ³ h ⁻¹ / 2000 ft ³ min ⁻¹
Booster speed	2750 rpm
Booster orientation	Horizontal
Pump displacement	1020 m ³ h ⁻¹ / 600 ft ³ min ⁻¹
Pressure switch required	Yes
Normal cut-in pressure	33 mbar / 25 Torr
Continuous operation pressure limit	6.7 mbar / 5 Torr
Booster drive	7.5 kW / 10 hp
Pump drive (TEFC)	7.5 kW (x2) / 10 hp (x2)
Inlet connections	8 inch ASA/ANSI flange
Discharge connections	3 inch ASA/ANSI flange, 3 inch NPT (x2)
Water inlet/outlet connection	½ inch NPT (x2)
Recommended cooling flow @ 30°C/85°F	7.6 lmin ⁻¹ (x2) / 2 galmin ⁻¹ (x2)
Booster oil capacity (V lube H)	1.9 litre / 0.51 US gal
Microvac oil capacity (V lube F)	92 litre / 24 US gal
Weight	2404 kg / 5300 lbs

Ordering Information

Product Description	Order No.
1738HC 230/460V, 3-ph, 60Hz (230/460V Coil)	90017C038
Accessories & Spares	Order No.
Replacement parts kit	429638015
Bearings	085019757
Valve deck assembly	607417001
Replacement 6" booster Mseal - seal kit	607552001
Replacement 6" booster - maintenance kit	607552002

Stokes 1738 HCBP Mechanical Booster Pump Combination

Whether you need to increase the capacity of your existing system or achieve peak performance for a new installation; Edwards makes taking advantage of the latest technology easy. These field-proven pumping systems are the workhorse of countless industrial and large chamber applications. Each Stokes1700 series mechanical booster pump combination includes a Stokes Microvac backing pump and a belt driven, horizontal flow, high vacuum Stokes 6" series mechanical booster pump. In harsh applications where chemical or particulate contamination is present, process isolation boosters are available as an option. Controls for Stokes 1700 series mechanical booster pump combination include a pressure switch, motor starters, overloads, remote booster selection switch and lights for pump running and fault indication.



Dimensions

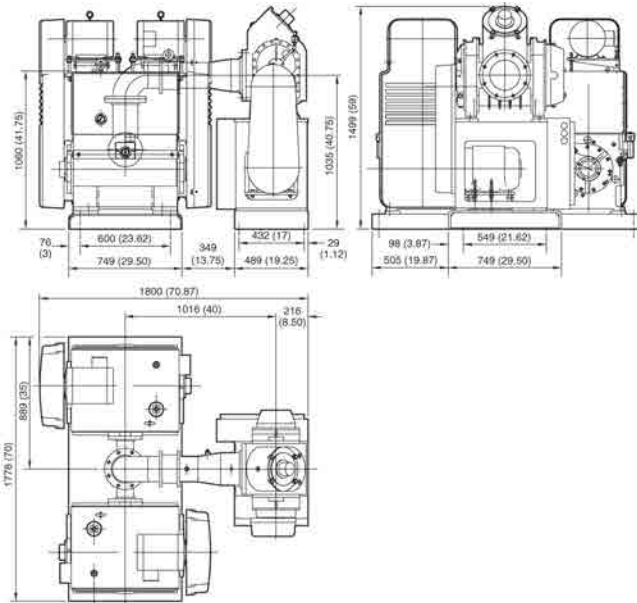

Performance Curves

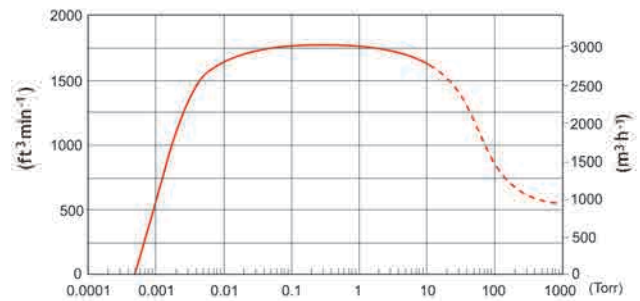

Technical Data

Booster displacement	3398 m ³ h ⁻¹ / 2000 ft ³ min ⁻¹
Booster speed	2750 rpm
Booster orientation	Horizontal
Pump displacement	1020 m ³ h ⁻¹ / 600 ft ³ min ⁻¹
Pressure switch required	No
Continuous operation pressure limit	6.7 mbar / 5 Torr
Booster drive	11.2 kW / 15 hp
Pump drive (TEFC)	7.5 kW (x2) / 10 hp (x2)
Inlet connections	8 inch ASA/ANSI flange
Discharge connections	3 inch ASA/ANSI flange, 3 inch NPT (x2)
Water inlet/outlet connection	½ inch NPT (x2)
Recommended cooling flow @ 30°C/85°F	7.6 lmin ⁻¹ (x2) / 2 galmin ⁻¹ (x2)
Booster oil capacity (V lube H)	1.9 litre / 0.51 US gal
Microvac oil capacity (V lube F)	92 litre / 24 US gal
Weight	2449 kg / 5400 lbs

Ordering Information

Product Description	Order No.
1738HCBP 230/460V, 3-ph, 60Hz (230/460V Coil)	90017C38B
Accessories & Spares	Order No.
Replacement parts kit	429638015
Bearings	085019757
Valve deck assembly	607417001
Replacement 6" booster Mseal - seal kit	607552001
Replacement 6" booster - maintenance kit	607552002

Stokes 1738HD Mechanical Booster Pump Combination



Whether you need to increase the capacity of your existing system or achieve peak performance for a new installation; Edwards makes taking advantage of the latest technology easy. These field-proven pumping systems are the workhorse of countless industrial and large chamber applications. Each Stokes1700 series mechanical booster pump combination includes a Stokes Microvac backing pump and a belt driven, horizontal flow, high vacuum Stokes 6" series mechanical booster pump. In harsh applications where chemical or particulate contamination is present, process isolation boosters are available as an option. Controls for Stokes 1700 series mechanical booster pump combination include a pressure switch, motor starters, overloads, remote booster selection switch and lights for pump running and fault indication.

Dimensions

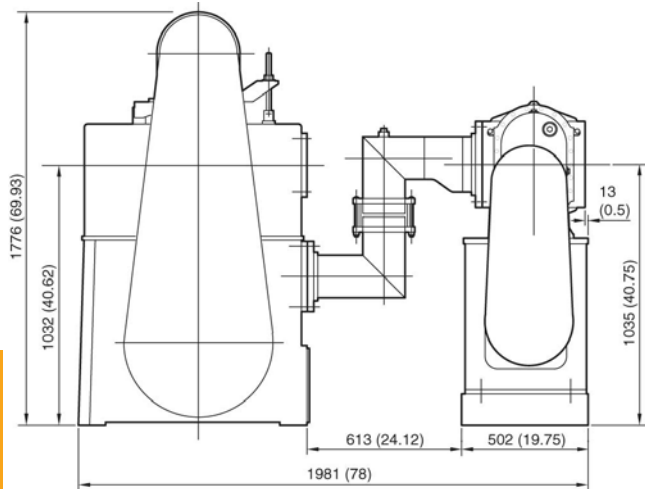

Performance Curves

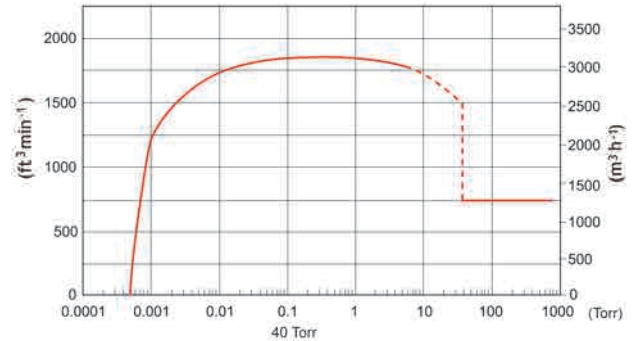

Technical Data

Booster displacement	3398 m ³ h ⁻¹ / 2000 ft ³ min ⁻¹
Booster speed	2750 rpm
Booster orientation	Horizontal
Pump displacement	1240 m ³ h ⁻¹ / 730 ft ³ min ⁻¹
Pressure switch required	Yes
Normal cut-in pressure	53 mbar / 40 Torr
Continuous operation pressure limit	16 mbar / 12 Torr
Booster drive	11 kW / 15 hp
Pump drive (TEFC)	22.5 kW / 30 hp
Inlet connections	8 inch ASA/ANSI flange
Discharge connections	5 inch NPT
Water inlet/outlet connection	1 inch NPT
Recommended cooling flow @ 30°C/85°F	18.9 lmin ⁻¹ / 5 galmin ⁻¹
Booster oil capacity (V lube H)	1.9 litre / 0.51 US gal
Microvac oil capacity (V lube F)	76 litre / 20 US gal
Weight	3187 kg / 7025 lbs

Ordering Information

Product Description	Order No.
1738HD 230/460V, 3-ph, 60Hz (230/460V Coil)	90017D038
Accessories & Spares	Order No.
Replacement roller bearing	085033795
Replacement oil seal	085018191
Roller bearing with adaptive sleeve	085033794
Valve deck stainless steel clappers	272963002
Replacement 6" booster Mseal - seal kit	607552001
Replacement 6" booster - maintenance kit	607552002
Valve deck springs	274172001

Stokes 1738HDBP Mechanical Booster Pump Combination

Whether you need to increase the capacity of your existing system or achieve peak performance for a new installation; Edwards makes taking advantage of the latest technology easy. These field-proven pumping systems are the workhorse of countless industrial and large chamber applications. Each Stokes1700 series mechanical booster pump combination includes a Stokes Microvac backing pump and a belt driven, horizontal flow, high vacuum Stokes 6" series mechanical booster pump. In harsh applications where chemical or particulate contamination is present, process isolation boosters are available as an option. Controls for Stokes 1700 series mechanical booster pump combination include a pressure switch, motor starters, overloads, remote booster selection switch and lights for pump running and fault indication.



Dimensions

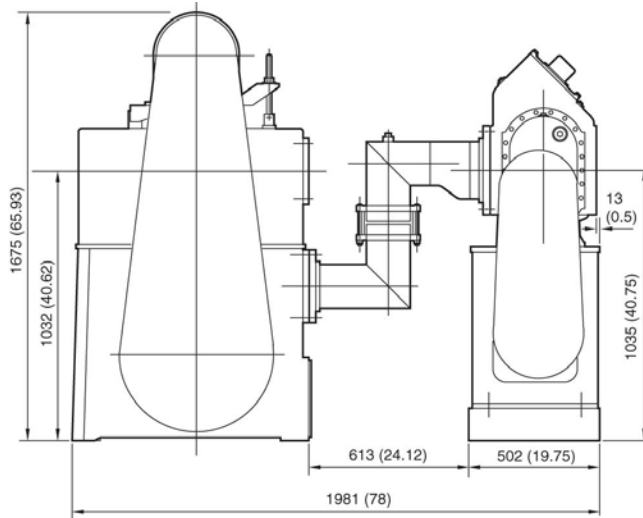

Performance Curves

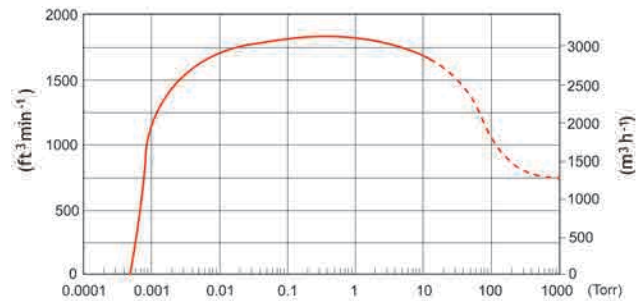

Technical Data

Booster displacement	3398 m ³ h ⁻¹ / 2000 ft ³ min ⁻¹
Booster speed	2750 rpm
Booster orientation	Horizontal
Pump displacement	1240 m ³ h ⁻¹ / 730 ft ³ min ⁻¹
Pressure switch required	No
Continuous operation pressure limit	16 mbar / 12 Torr
Booster drive	11 kW / 15 hp
Pump drive (TEFC)	22 kW / 30 hp
Inlet connections	8 inch ASA/ANSI flange
Discharge connections	5 inch NPT
Water inlet/outlet connection	1 inch NPT
Recommended cooling flow @ 30°C/85 °F	18.9 lmin ⁻¹ / 5 galmin ⁻¹
Booster oil capacity (V lube H)	1.9 litre / 0.51 US gal
Microvac oil capacity (V lube F)	76 litre / 20 US gal
Weight	3221 kg / 7100 lbs

Ordering Information

Product Description	Order No.
1738HDBP 230/460V, 3-ph, 60Hz (230/460V Coil)	90017D38B
Accessories & Spares	Order No.
Replacement 6" booster Mseal - seal kit	607552001
Replacement 6" booster - maintenance kit	607552002
Replacement oil seal	085018191
Replacement roller bearing	085033795
Roller bearing with adaptive sleeve	085033794
Valve deck stainless steel clappers	272963002
Valve deck springs	274172001

Stokes 1739 Mechanical Booster Pump Combination



Whether you need to increase the capacity of your existing system or achieve peak performance for a new installation; Edwards makes taking advantage of the latest technology easy. These field-proven pumping systems are the workhorse of countless industrial and large chamber applications. Each Stokes1700 series mechanical booster pump combination includes a Stokes Microvac backing pump and a belt driven, horizontal flow, high vacuum Stokes 6" series mechanical booster pump. In harsh applications where chemical or particulate contamination is present, process isolation boosters are available as an option. Controls for Stokes 1700 series mechanical booster pump combination include a pressure switch, motor starters, overloads, remote booster selection switch and lights for pump running and fault indication.

Dimensions

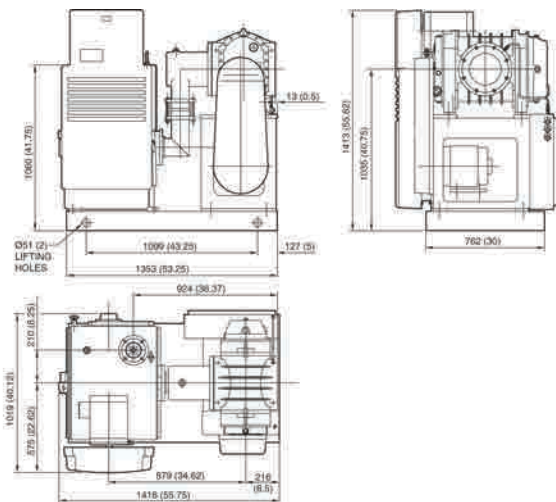

Performance Curves

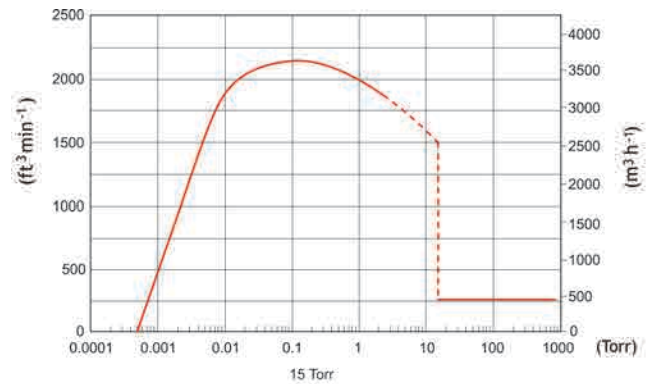

Technical Data

Booster displacement	4420 m ³ h ⁻¹ / 2600 ft ³ min ⁻¹
Booster	3600 rpm
Booster orientation	Horizontal
Pump displacement	510 m ³ h ⁻¹ / 300 ft ³ min ⁻¹
Pressure switch required	Yes
Normal cut-in pressure	13 mbar / 15 Torr
Continuous operation pressure limit	2.7 mbar / 2 Torr
Booster drive	22.4 kW / 30 hp
Pump drive (TEFC)	7.5 kW / 10 hp
Inlet connections	8 inch ASA/ANSI flange
Discharge connections	3 inch ASA/ANSI flange, 3 inch NPT
Water inlet/outlet connection	½ inch NPT
Recommended cooling flow @ 30°C/85 °F	7.6 lmin ⁻¹ / 2 galmin ⁻¹
Booster oil capacity (V lube H)	1.9 litre / 0.51 US gal
Microvac oil capacity (V lube F)	46 litre / 12 US gal
Inlet height	1067 mm / 42 inch
Footprint (L x W x H)	1905 x 1270 x 1318 mm 75 x 50 x 51.89 inch
Weight	1803 kg / 3975 lbs

Ordering Information

Product Description	Order No.
1739 230/460V, 3-ph, 60Hz (230/460V Coil)	900170039
Accessories & Spares	Order No.
Replacement parts kit	429638015
Bearings	085019757
Valve deck assembly	607417001
Replacement 6" booster Mseal - seal kit	607552001
Replacement 6" booster - maintenance kit	607552002

Stokes 1739BP Mechanical Booster Pump Combination

Whether you need to increase the capacity of your existing system or achieve peak performance for a new installation; Edwards makes taking advantage of the latest technology easy. These field-proven pumping systems are the workhorse of countless industrial and large chamber applications. Each Stokes1700 series mechanical booster pump combination includes a Stokes Microvac backing pump and a belt driven, horizontal flow, high vacuum Stokes 6" series mechanical booster pump. In harsh applications where chemical or particulate contamination is present, process isolation boosters are available as an option. Controls for Stokes 1700 series mechanical booster pump combination include a pressure switch, motor starters, overloads, remote booster selection switch and lights for pump running and fault indication.



Dimensions

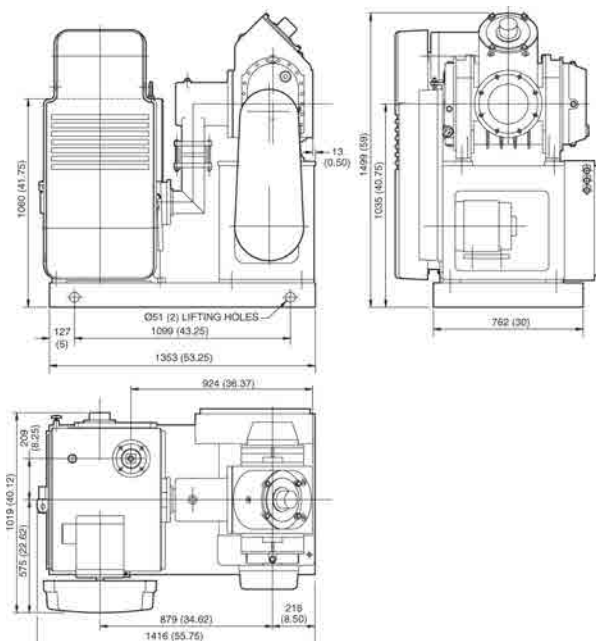

Performance Curves

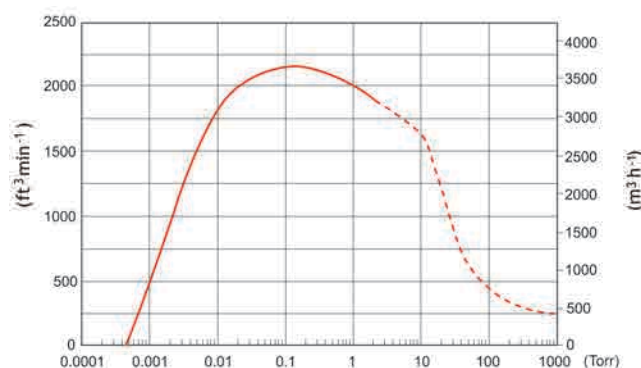

Technical Data

Booster displacement	4420 m ³ h ⁻¹ / 2600 ft ³ min ⁻¹
Booster speed	3600 rpm
Booster orientation	Horizontal
Pump displacement	510 m ³ h ⁻¹ / 300 ft ³ min ⁻¹
Pressure switch required	No
Continuous operation pressure limit	2.7 mbar / 2 Torr
Booster drive	22 kW / 30 hp
Pump drive (TEFC)	7.5 kW / 10 hp
Inlet connections	8 inch ASA/ANSI flange
Discharge connections	3 inch ASA/ANSI flange, 3 inch NPT
Water inlet/outlet connection	½ inch NPT
Recommended cooling flow @ 30°C/85 °F	7.6 lmin ⁻¹ / 2 galmin ⁻¹
Booster oil capacity (V lube H)	1.9 litre / 0.51 US gal
Microvac oil capacity (V lube F)	46 litre / 12 US gal
Weight	1837 kg / 4050 lbs

Ordering Information

Product Description	Order No.
1739BP High Capacity Mechanical Booster Pump Combination 230/460V, 3Ø, 60 Hz with 230/460V Coil	90017039B
Accessories & Spares	Order No.
Replacement parts kit	429638015
Bearings	085019757
Valve deck assembly	607417001
Replacement 6" booster Mseal - seal kit	607552001
Replacement 6" booster - maintenance kit	607552002

Stokes 1739HC Mechanical Booster Pump Combination



Whether you need to increase the capacity of your existing system or achieve peak performance for a new installation; Edwards makes taking advantage of the latest technology easy. These field-proven pumping systems are the workhorse of countless industrial and large chamber applications. Each Stokes1700 series mechanical booster pump combination includes a Stokes Microvac backing pump and a belt driven, horizontal flow, high vacuum Stokes 6" series mechanical booster pump. In harsh applications where chemical or particulate contamination is present, process isolation boosters are available as an option. Controls for Stokes 1700 series mechanical booster pump combination include a pressure switch, motor starters, overloads, remote booster selection switch and lights for pump running and fault indication.

Dimensions

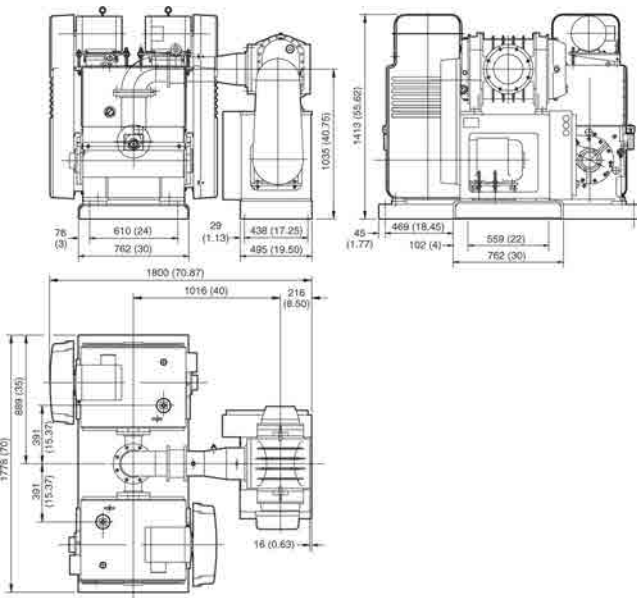

Performance Curves

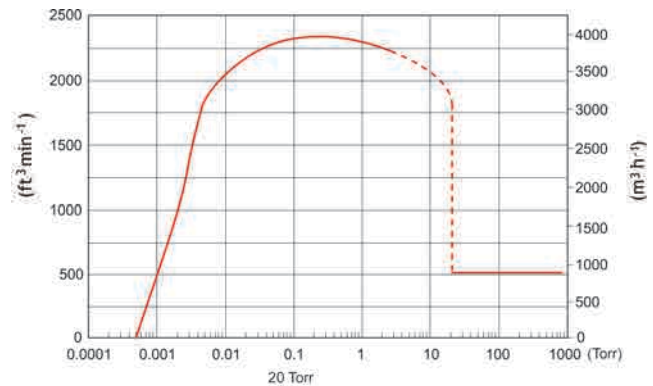

Technical Data

Booster displacement	4420 m ³ h ⁻¹ / 2600 ft ³ min ⁻¹
Booster speed	3600 rpm
Booster orientation	Horizontal
Pump displacement	1020 m ³ h ⁻¹ / 600 ft ³ min ⁻¹
Pressure switch required	Yes
Normal cut-in pressure	33 mbar / 20 Torr
Continuous operation pressure limit	3.4 mbar / 2.5 Torr
Booster drive	18.6 kW / 25 hp
Pump drive (TEFC)	7.5 kW (x2) / 10 hp (x2)
Inlet connections	8 inch ASA/ANSI flange
Discharge connections	3 inch ASA/ANSI flange, 3 inch NPT (x2)
Water inlet/outlet connection	½ inch NPT (x2)
Recommended cooling flow @ 30°C/85°F	7.6 lmin ⁻¹ (x2) / 2 galmin ⁻¹ (x2)
Booster oil capacity (V lube H)	1.9 litre / 0.51 US gal
Microvac oil capacity (V lube F)	92 litre / 24 US gal
Weight	2733 kg / 6025 lbs

Ordering Information

Product Description	Order No.
1739HC 230/460V, 3-ph, 60Hz (230/460V Coil)	90017C039
Accessories & Spares	Order No.
Replacement parts kit	429638015
Bearings	085019757
Valve deck assembly	607417001
Replacement 6" booster Mseal - seal kit	607552001
Replacement 6" booster - maintenance kit	607552002

Stokes 1739HCBP Mechanical Booster Pump Combination

Whether you need to increase the capacity of your existing system or achieve peak performance for a new installation; Edwards makes taking advantage of the latest technology easy. These field-proven pumping systems are the workhorse of countless industrial and large chamber applications. Each Stokes1700 series mechanical booster pump combination includes a Stokes Microvac backing pump and a belt driven, horizontal flow, high vacuum Stokes 6" series mechanical booster pump. In harsh applications where chemical or particulate contamination is present, process isolation boosters are available as an option. Controls for Stokes 1700 series mechanical booster pump combination include a pressure switch, motor starters, overloads, remote booster selection switch and lights for pump running and fault indication.



Dimensions

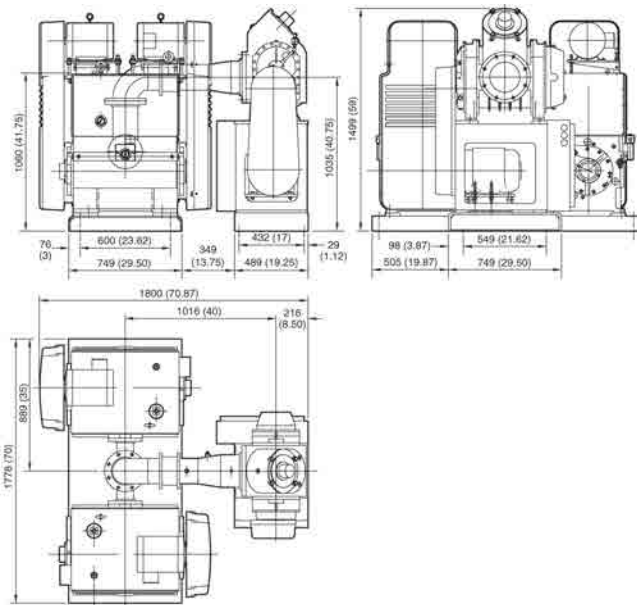

Performance Curves

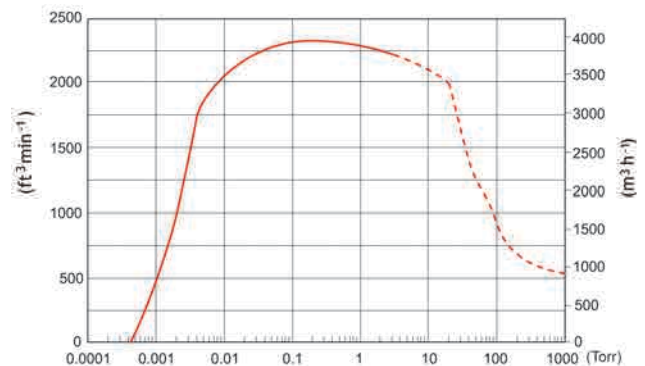

Technical Data

Booster displacement	4420 m ³ h ⁻¹ / 2600 ft ³ min ⁻¹
Booster speed	3600 rpm
Booster orientation	Horizontal
Pump displacement	1020 m ³ h ⁻¹ / 600 ft ³ min ⁻¹
Pressure switch required	No
Continuous operation pressure limit	4 mbar / 3 Torr
Booster drive	18.6 kW / 25 hp
Pump drive (TEFC)	7.5 kW (x2) / 10 hp (x2)
Inlet connections	8 inch ASA/ANSI flange
Discharge connections	3 inch ASA/ANSI flange, 3 inch NPT (x2)
Water inlet/outlet connection	½ inch NPT (x2)
Recommended cooling flow @ 30°C/85°F	7.6 lmin ⁻¹ (x2) / 2 galmin ⁻¹ (x2)
Booster oil capacity (V lube H)	1.9 litre / 0.51 US gal
Microvac oil capacity (V lube F)	92 litre / 24 US gal
Weight	2767 kg / 6100 lbs

Ordering Information

Product Description	Order No.
1739HCBP 230/460V, 3-ph, 60Hz (230/460V Coil)	90017C39B
Accessories & Spares	Order No.
Replacement parts kit	429638015
Bearings	085019757
Valve deck assembly	607417001
Replacement 6" booster Mseal - seal kit	607552001
Replacement 6" booster - maintenance kit	607552002

Stokes 1739HD Mechanical Booster Pump Combination



Whether you need to increase the capacity of your existing system or achieve peak performance for a new installation; Edwards makes taking advantage of the latest technology easy. These field-proven pumping systems are the workhorse of countless industrial and large chamber applications. Each Stokes1700 series mechanical booster pump combination includes a Stokes Microvac backing pump and a belt driven, horizontal flow, high vacuum Stokes 6" series mechanical booster pump. In harsh applications where chemical or particulate contamination is present, process isolation boosters are available as an option. Controls for Stokes 1700 series mechanical booster pump combination include a pressure switch, motor starters, overloads, remote booster selection switch and lights for pump running and fault indication.

Dimensions

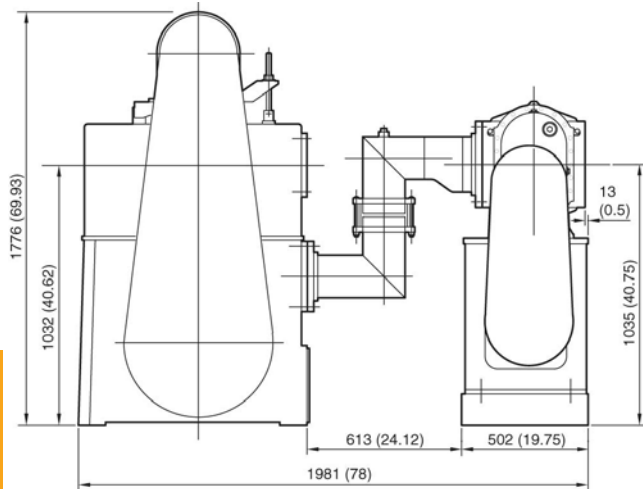

Performance Curves

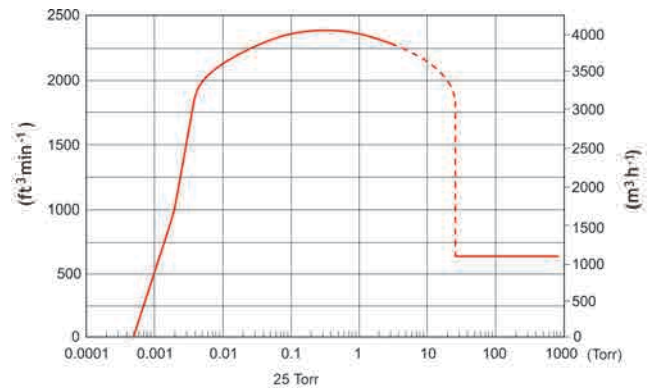

Technical Data

Booster displacement	4420 m ³ h ⁻¹ / 2600 ft ³ min ⁻¹
Booster speed	3600 rpm
Booster orientation	Horizontal
Pump displacement	1240 m ³ h ⁻¹ / 730 ft ³ min ⁻¹
Pressure switch required	Yes
Normal cut-in pressure	47 mbar / 25 Torr
Continuous operation pressure limit	4 mbar / 3 Torr
Booster drive	18.5 kW / 25 hp
Pump drive (TEFC)	22.5 kW / 30 hp
Inlet connections	8 inch ASA/ANSI flange
Discharge connections	5 inch NPT
Water inlet/outlet connection	1 inch NPT
Recommended cooling flow @ 30°C/85 °F	18.9 lmin ⁻¹ / 5 galmin ⁻¹
Booster oil capacity (V lube H)	1.9 litre / 0.51 US gal
Microvac oil capacity (V lube F)	76 litre / 20 US gal
Weight	3504 kg / 7725 lbs

Ordering Information

Product Description	Order No.
1739HD 230/460V, 3-ph, 60Hz (230/460V Coil)	90017D039
Accessories & Spares	Order No.
Replacement roller bearing	085033795
Replacement oil seal	085018191
Roller bearing with adaptive sleeve	085033794
Valve deck stainless steel clappers	272963002
Replacement 6" booster Mseal - seal kit	607552001
Replacement 6" booster - maintenance kit	607552002
Valve deck springs	274172001

Stokes 1739HDBP Mechanical Booster Pump Combination

Whether you need to increase the capacity of your existing system or achieve peak performance for a new installation; Edwards makes taking advantage of the latest technology easy. These field-proven pumping systems are the workhorse of countless industrial and large chamber applications. Each Stokes1700 series mechanical booster pump combination includes a Stokes Microvac backing pump and a belt driven, horizontal flow, high vacuum Stokes 6" series mechanical booster pump. In harsh applications where chemical or particulate contamination is present, process isolation boosters are available as an option. Controls for Stokes 1700 series mechanical booster pump combination include a pressure switch, motor starters, overloads, remote booster selection switch and lights for pump running and fault indication.



Dimensions

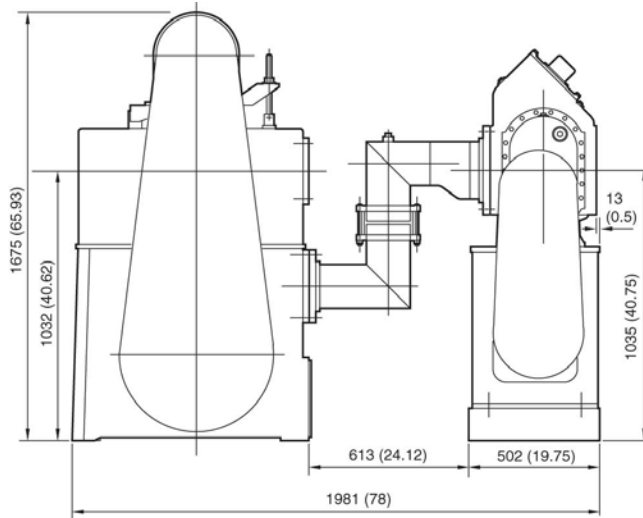

Performance Curves

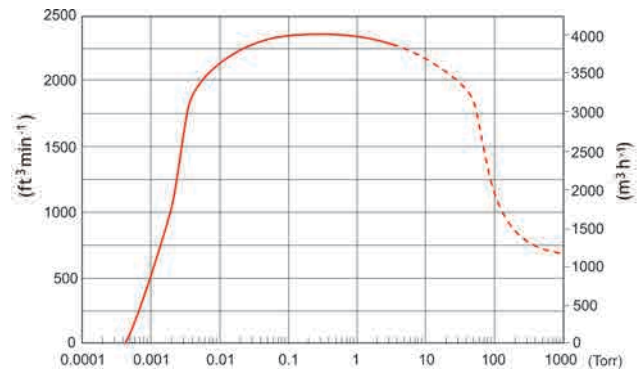

Technical Data

Booster displacement	4420 m ³ h ⁻¹ / 2600 ft ³ min ⁻¹
Booster speed	3600 rpm
Booster orientation	Horizontal
Pump displacement	1240 m ³ h ⁻¹ / 730 ft ³ min ⁻¹
Pressure switch required	No
Continuous operation pressure limit	4 mbar / 3 Torr
Booster drive	18.5 kW / 25 hp
Pump drive	22.5 kW / 30 hp
Inlet connections	8 inch ASA/ANSI flange
Discharge connections	5 inch NPT
Water inlet/outlet connection	1 inch NPT
Recommended cooling flow @ 30°C/85°F	18.9 lmin ⁻¹ / 5 galmin ⁻¹
Booster oil capacity (V lube H)	1.9 litre / 0.51 US gal
Microvac oil capacity (V lube F)	76 litre / 20 US gal
Weight	3538 kg / 7800 lbs

Ordering Information

Product Description	Order No.
1739HDBP 230/460V, 3-ph, 60Hz (230/460V Coil)	90017D39B
Accessories & Spares	Order No.
Replacement 6" booster Mseal - seal kit	607552001
Replacement 6" booster - maintenance kit	607552002
Replacement oil seal	085018191
Replacement roller bearing	085033795
Roller bearing with adaptive sleeve	085033794
Valve deck stainless steel clappers	272963002
Valve deck springs	274172001

Stokes 1754 Mechanical Booster Pump Combination



Whether you need to increase the capacity of your existing system or achieve peak performance for a new installation; Edwards makes taking advantage of the latest technology easy. These field-proven pumping systems are the workhorse of countless industrial and large chamber applications. Each Stokes 1700 series mechanical booster pump combination includes a Stokes Microvac backing pump and a belt driven, horizontal flow, high vacuum Stokes 6" series mechanical booster pump. In harsh applications where chemical or particulate contamination is present, process isolation boosters are available as an option. Controls for Stokes 1700 series mechanical booster pump combination include a pressure switch, motor starters, overloads, remote booster selection switch and lights for pump running and fault indication.

Dimensions

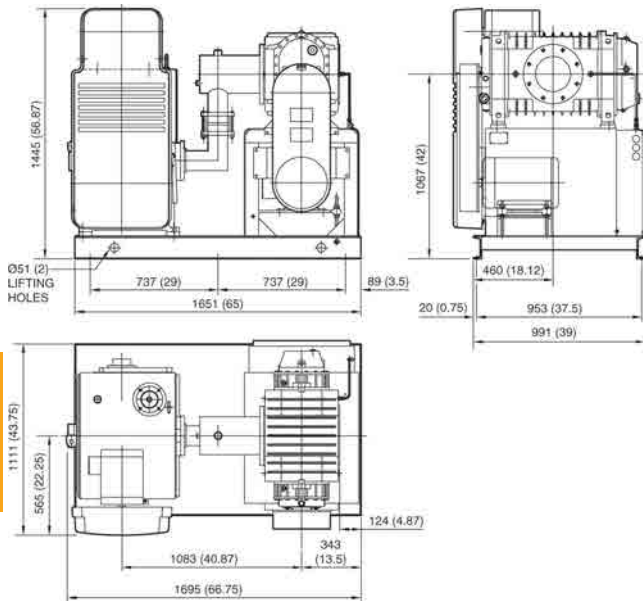

Performance Curves

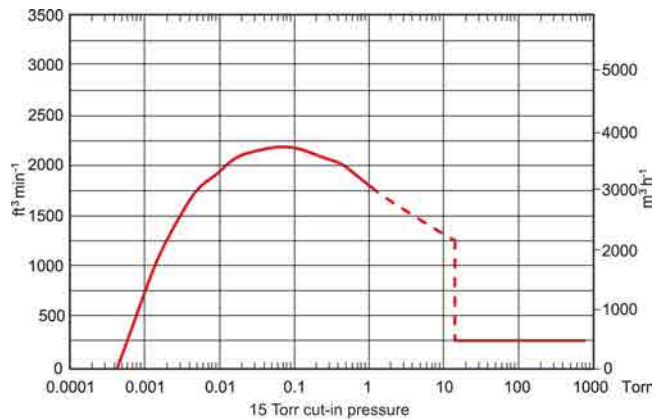

Technical Data

Booster displacement	5100 m ³ h ⁻¹ / 3000 ft ³ min ⁻¹
Booster speed	2750 rpm
Booster orientation	Horizontal
Pump displacement	510 m ³ h ⁻¹ / 300 ft ³ min ⁻¹
Pressure switch required	Yes
Normal cut-in pressure	20 mbar / 15 Torr
Continuous operation pressure limit	1.3 mbar / 1 Torr
Booster drive	15 kW / 20 hp
Pump drive	7.5 kW / 10 hp
Inlet connections	8 inch ASA/ANSI flange
Discharge connections	3 inch ASA/ANSI flange, 3 inch NPT
Water inlet connection	½ inch NPT (2)
Water outlet connection	½ inch NPT
Recommended cooling flow @ 30°C/85°F	7.6 lmin ⁻¹ / 2 galmin ⁻¹
Booster oil capacity (V lube H)	1.9 litre / 0.51 US gal
Microvac oil capacity (V lube F)	46 litre / 12 US gal
Weight	1678 kg / 3700 lbs

Ordering Information

Product Description	Order No.
1754 230/460V, 3-ph, 60Hz (230/460V Coil)	900170054
Accessories & Spares	Order No.
Replacement parts kit	429638015
Replacement 6" booster Mseal - seal kit	607552001
Bearings	085019757
Valve deck assembly	607417001
Replacement 6" booster - maintenance kit	607552002

Stokes 1754HC Mechanical Booster Pump Combination

Whether you need to increase the capacity of your existing system or achieve peak performance for a new installation; Edwards makes taking advantage of the latest technology easy. These field-proven pumping systems are the workhorse of countless industrial and large chamber applications. Each Stokes1700 series mechanical booster pump combination includes a Stokes Microvac backing pump and a belt driven, horizontal flow, high vacuum Stokes 6" series mechanical booster pump. In harsh applications where chemical or particulate contamination is present, process isolation boosters are available as an option. Controls for Stokes 1700 series mechanical booster pump combination include a pressure switch, motor starters, overloads, remote booster selection switch and lights for pump running and fault indication.



Dimensions

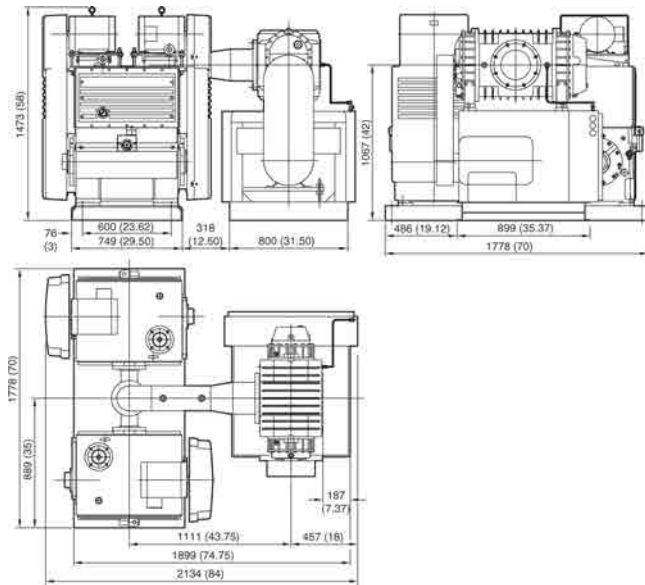

Performance Curves

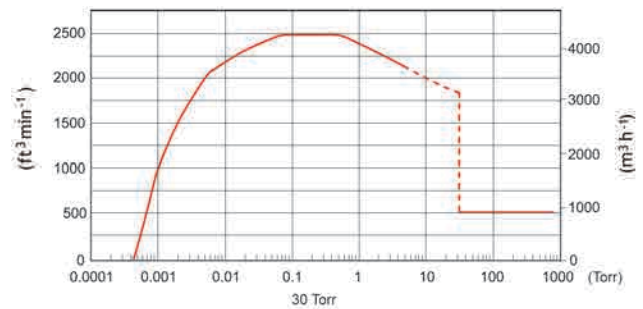

Technical Data

Booster displacement	5100 m ³ h ⁻¹ / 3000 ft ³ min ⁻¹
Booster speed	2750 rpm
Booster orientation	Horizontal
Pump displacement	1020 m ³ h ⁻¹ / 600 ft ³ min ⁻¹
Pressure switch required	Yes
Normal cut-in pressure	40 mbar / 30 Torr
Continuous operation pressure limit	4 mbar / 3 Torr
Booster drive	18.5 kW / 25 hp
Pump drive	7.5 kW (x2) / 10 hp (x2)
Inlet connections	8 inch ASA/ANSI flange
Discharge connections	3 inch ASA/ANSI flange, 3 inch NPT (x2)
Water inlet/outlet connection	½ inch NPT (x2)
Recommended cooling flow @ 30°C/85°F	7.6 l min ⁻¹ (x2) / 2 gal min ⁻¹ (x2)
Booster oil capacity (V lube H)	1.9 litre / 0.51 US gal
Microvac oil capacity (V lube F)	92 litre / 24 US gal
Weight	2722 kg / 6000 lbs

Ordering Information

Product Description	Order No.
1754HC 230/460V, 3-ph, 60Hz (230/460V Coil)	900170055
Accessories & Spares	Order No.
Replacement parts kit	429638015
Bearings	085019757
Valve deck assembly	607417001
Replacement 6" booster Mseal - seal kit	607552001
Replacement 6" booster - maintenance kit	607552002

EV20 Oil Sealed Pump



The EV rotary vane pumps are designed to be used in a wide range of industrial and scientific applications. They can be used individually or with mechanical booster pumps to increase both performance and ultimate vacuum. They can operate continuously from atmosphere to ultimate.

With reliability and ease of service in mind, the EV range of pumps are designed for the industrial and scientific markets. Edwards Applications Specialists have unrivalled knowledge and can advise on pump selection, configuration and operation to suit any customers' requirements. The EV range can be supplied individually or as part of pre-engineered combinations using Edwards EH mechanical boosters.

Features & Benefits

- Continuous operation from atmosphere to ultimate vacuum
- High pumping speed at low pressure
- Gas ballast valve fitted as standard
- Low noise and vibration
- Air cooled

Dimensions

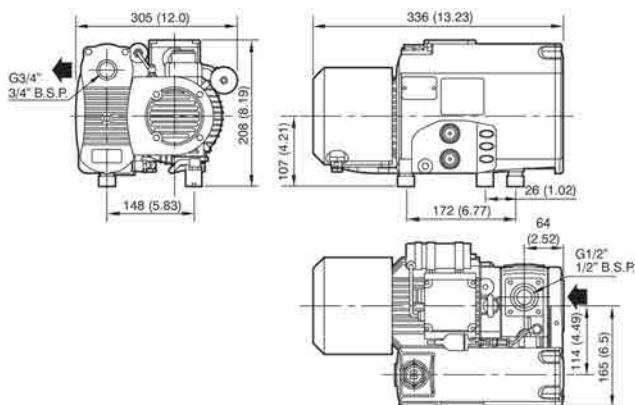

Applications

- Furnaces and metallurgy industries
- Food processing and packaging
- Lifting
- Vacuum coating
- Vacuum transporting

Performance Curves

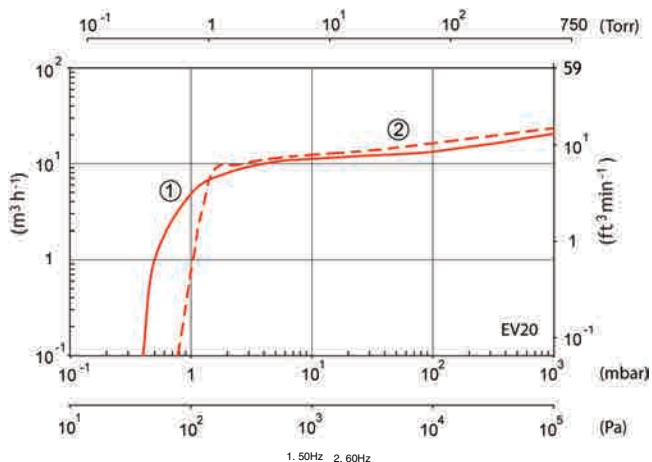

Technical Data

Pumping speed 50 Hz	18 m ³ h ⁻¹ / 11 ft ³ min ⁻¹
Pumping speed 60 Hz	21 m ³ h ⁻¹ / 13 ft ³ min ⁻¹
Ultimate pressure without Gas Ballast	0.5 mbar
Water vapour capacity	0.4 kg h ⁻¹ @ 10 mbar / 0.9 lb h ⁻¹ @ 10 mbar
Electricity supply 50 Hz	175-260 / 300-450 V
Electricity supply 60 Hz	190-290 / 330-500 V
Motor Power 50 Hz	0.55 kW / 0.75hp
Motor Power 60 Hz	0.66 kW / 1.0 hp
Noise 50 Hz	63 dB(A)
Noise 60 Hz	67 dB(A)
Weight	20 kg / 44 lbs
Oil capacity	0.5 litre / 0.13 US gal
Oil Type	UG20

Ordering Information

Product Description	Order No.
EV20 175-260/300-450V, 50Hz, 190-290/330-500V, 60Hz	A35010940

EV40 Oil Sealed Pump

The EV rotary vane pumps are designed to be used in a wide range of industrial and scientific applications. They can be used individually or with mechanical booster pumps to increase both performance and ultimate vacuum. They can operate continuously from atmosphere to ultimate.

With reliability and ease of service in mind, the EV range of pumps are designed for the industrial and scientific markets. Edwards Applications Specialists have unrivalled knowledge and can advise on pump selection, configuration and operation to suit any customers' requirements. The EV range can be supplied individually or as part of pre-engineered combinations using Edwards EH mechanical boosters.



Features & Benefits

- Continuous operation from atmosphere to ultimate vacuum
- High pumping speed at low pressure
- Gas ballast valve fitted as standard
- Low noise and vibration
- Air cooled

Dimensions

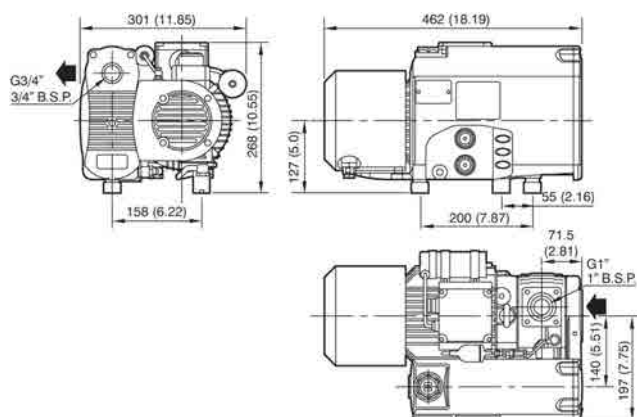

Applications

- Furnaces and metallurgy industries
- Food processing and packaging
- Lifting
- Vacuum coating
- Vacuum transporting

Performance Curves

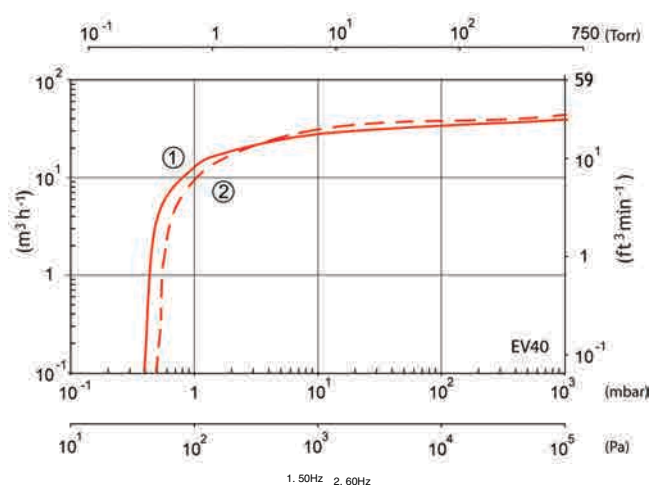

Technical Data

Pumping speed 50 Hz	41 m ³ h ⁻¹ / 25 ft ³ min ⁻¹
Pumping speed 60 Hz	48 m ³ h ⁻¹ / 29 ft ³ min ⁻¹
Ultimate pressure without Gas Ballast	0.5 mbar
Water vapour capacity	0.3 kg h ⁻¹ @ 10 mbar / 0.7 lb h ⁻¹ @ 10 mbar
Electricity supply 50 Hz	190-255 / 330-440 V
Electricity supply 60 Hz	190-290 / 330-500 V
Motor Power 50 Hz	1.5 kW / 2.0 hp
Motor Power 60 Hz	1.8 kW / 2.5 hp
Noise 50 Hz	69 dB(A)
Noise 60 Hz	71 dB(A)
Weight	38 kg / 84 lbs
Oil capacity	1 litre / 0.26 US gal
Oil Type	UG20

Ordering Information

Product Description	Order No.
EV40 190-255/330-440V, 50Hz, 190-290/330-500V, 60Hz	A35015940

EV70 Oil Sealed Pump



The EV rotary vane pumps are designed to be used in a wide range of industrial and scientific applications. They can be used individually or with mechanical booster pumps to increase both performance and ultimate vacuum. They can operate continuously from atmosphere to ultimate.

With reliability and ease of service in mind, the EV range of pumps are designed for the industrial and scientific markets. Edwards Applications Specialists have unrivalled knowledge and can advise on pump selection, configuration and operation to suit any customers' requirements. The EV range can be supplied individually or as part of pre-engineered combinations using Edwards EH mechanical boosters.

Features & Benefits

- Continuous operation from atmosphere to ultimate vacuum
- High pumping speed at low pressure
- Gas ballast valve fitted as standard
- Low noise and vibration
- Air cooled

Dimensions

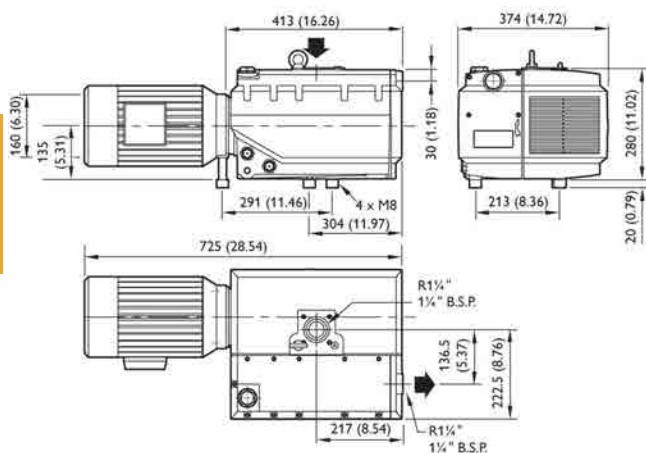

Applications

- Furnaces and metallurgy industries
- Food processing and packaging
- Lifting
- Vacuum coating
- Vacuum transporting

Performance Curves

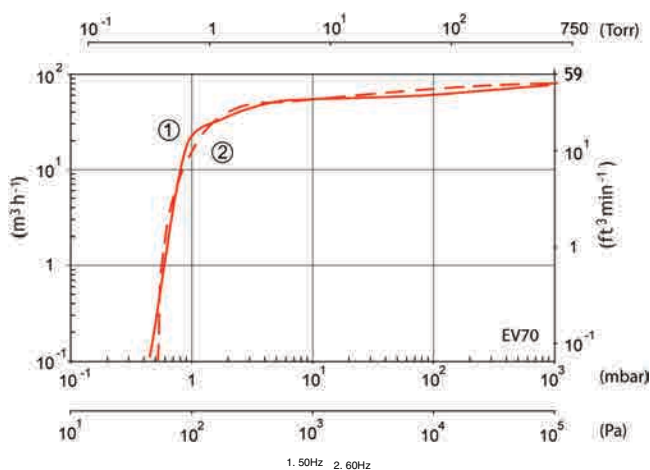

Technical Data

Pumping speed 50 Hz	58 m ³ h ⁻¹ / 35 ft ³ min ⁻¹
Pumping speed 60 Hz	73 m ³ h ⁻¹ / 44 ft ³ min ⁻¹
Ultimate pressure without gas ballast	0.5 mbar
Water vapour capacity	0.57 kg h ⁻¹ @ 10 mbar / 1.3 lb h ⁻¹ @ 10 mbar
Electricity supply 50 Hz	190-255 / 330-440 V
Electricity supply 60 Hz	190-290 / 330-500 V
Motor Power 50 Hz	2.4 kW / 3.25hp
Motor Power 60 Hz	3 kW / 4.0hp
Noise 50 Hz	67 dB(A)
Noise 60 Hz	68.5 dB(A)
Weight	62 kg / 136 lbs
Oil capacity	2 litre / 0.53 US gal
Oil Type	UG20

Ordering Information

Product Description	Order No.
EV70 190-255/330-440V, 50Hz, 190-290/330-500V, 60Hz	A35020940

EV100 Oil Sealed Pump

The EV rotary vane pumps are designed to be used in a wide range of industrial and scientific applications. They can be used individually or with mechanical booster pumps to increase both performance and ultimate vacuum. They can operate continuously from atmosphere to ultimate.

With reliability and ease of service in mind, the EV range of pumps are designed for the industrial and scientific markets. Edwards Applications Specialists have unrivalled knowledge and can advise on pump selection, configuration and operation to suit any customers' requirements. The EV range can be supplied individually or as part of pre-engineered combinations using either Edwards EH mechanical boosters.



Features & Benefits

- Continuous operation from atmosphere to ultimate vacuum
- High pumping speed at low pressure
- Gas ballast valve fitted as standard
- Low noise and vibration
- Air cooled

Dimensions

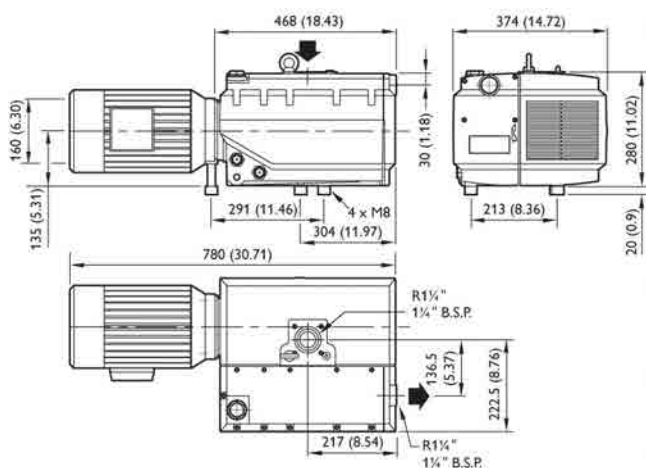

Applications

- Furnaces and metallurgy industries
- Food processing and packaging
- Lifting
- Vacuum coating
- Vacuum transporting

Performance Curves

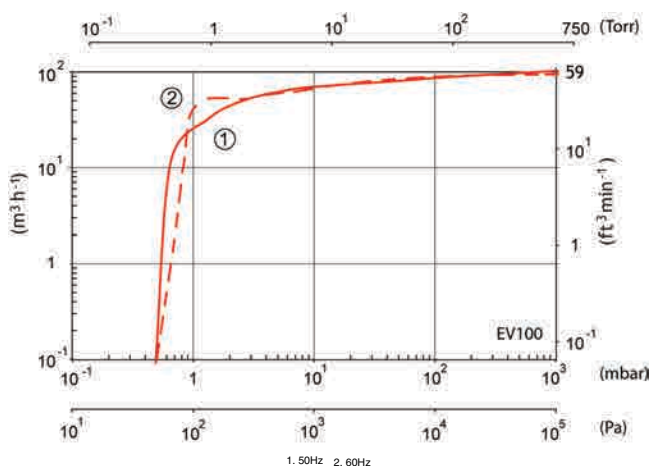

Technical Data

Pumping speed 50 Hz	100 m ³ h ⁻¹ / 60 ft ³ min ⁻¹
Pumping speed 60 Hz	117 m ³ h ⁻¹ / 70 ft ³ min ⁻¹
Ultimate pressure without gas ballast	0.5 mbar
Water vapor capacity	0.36 kg h ⁻¹ @ 10 mbar / 0.8 lb h ⁻¹ @ 10 mbar
Electricity supply 50 Hz	190-255 / 330-440 V
Electricity supply 60 Hz	190-290 / 330-500 V
Motor Power 50 Hz	2.4 kW / 3.25 hp
Motor Power 60 Hz	3 kW / 4.0 hp
Noise 50 Hz	67.5 dB(A)
Noise 60 Hz	69 dB(A)
Weight	65 kg / 143 lbs
Oil capacity	2 litre / 0.53 US gal
Oil Type	UG20

Ordering Information

Product Description	Order No.
EV100 190-255/330-440V, 50Hz, 190-290/330-500V, 60Hz	A35025940

EV160 Oil Sealed Pump



The EV rotary vane pumps are designed to be used in a wide range of industrial and scientific applications. They can be used individually or with mechanical booster pumps to increase both performance and ultimate vacuum. They can operate continuously from atmosphere to ultimate.

With reliability and ease of service in mind, the EV range of pumps are designed for the industrial and scientific markets. Edwards Applications Specialists have unrivalled knowledge and can advise on pump selection, configuration and operation to suit any customers' requirements. The EV range can be supplied individually or as part of pre-engineered combinations using Edwards EH mechanical boosters.

Features & Benefits

- Continuous operation from atmosphere to ultimate vacuum
- High pumping speed at low pressure
- Gas ballast valve fitted as standard
- Low noise and vibration
- Air cooled

Dimensions

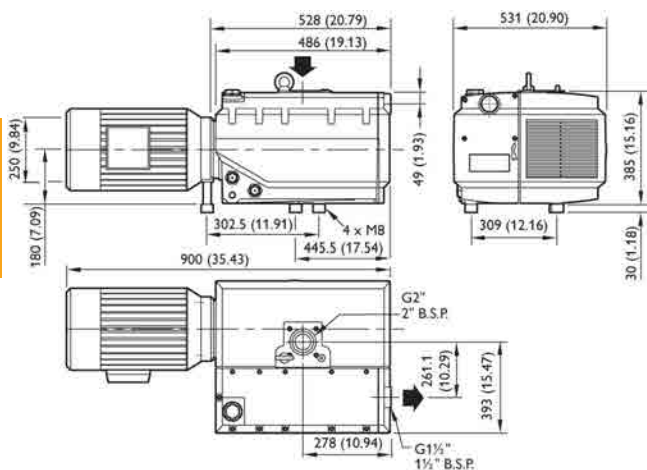

Applications

- Furnaces and metallurgy industries
- Food processing and packaging
- Lifting
- Vacuum coating
- Vacuum transporting

Performance Curves

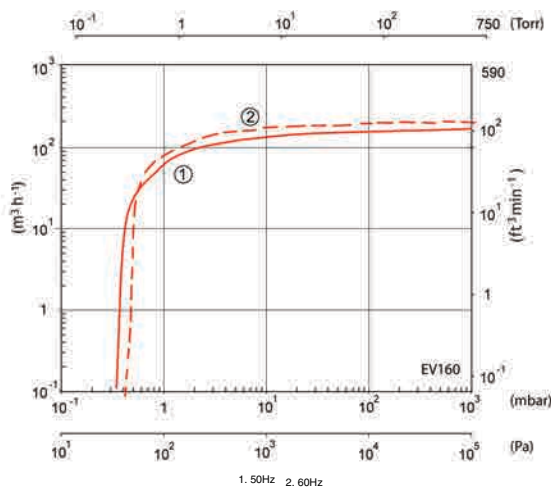

Technical Data

Pumping speed 50 Hz	$160 \text{ m}^3 \text{ h}^{-1} / 96 \text{ ft}^3 \text{ min}^{-1}$
Pumping speed 60 Hz	$192 \text{ m}^3 \text{ h}^{-1} / 116 \text{ ft}^3 \text{ min}^{-1}$
Ultimate pressure without gas ballast	0.5 mbar
Water vapour capacity	$1.2 \text{ kg h}^{-1} @ 10 \text{ mbar} / 2.6 \text{ lb h}^{-1} @ 10 \text{ mbar}$
Electricity supply 50 Hz	190-255 / 330-440 V
Electricity supply 60 Hz	190-290 / 330-500 V
Motor Power 50 Hz	4 kW / 5.5 hp
Motor Power 60 Hz	4.8 kW / 6.5 hp
Noise 50 Hz	71 dB(A)
Noise 60 Hz	74 dB(A)
Weight	129 kg / 284 lbs
Oil capacity	7 litre / 1.84 US gal
Oil Type	UG20

Ordering Information

Product Description	Order No.
EV160 190-255/330-440V, 50Hz, 190-290/330-500V, 60Hz	A35030940

EV200 Rotary vane pump

The EV rotary vane pumps are designed to be used in a wide range of industrial and scientific applications. They can be used individually or with mechanical booster pumps to increase both performance and ultimate vacuum. They can operate continuously from atmosphere to ultimate.

With reliability and ease of service in mind, the EV range of pumps are designed for the industrial and scientific markets. Edwards Applications Specialists have unrivalled knowledge and can advise on pump selection, configuration and operation to suit any customers' requirements. The EV range can be supplied individually or as part of pre-engineered combinations using Edwards EH mechanical boosters.



Features & Benefits

- Continuous operation from atmosphere to ultimate vacuum
- High pumping speed at low pressure
- Gas ballast valve fitted as standard
- Low noise and vibration
- Air cooled

Dimensions

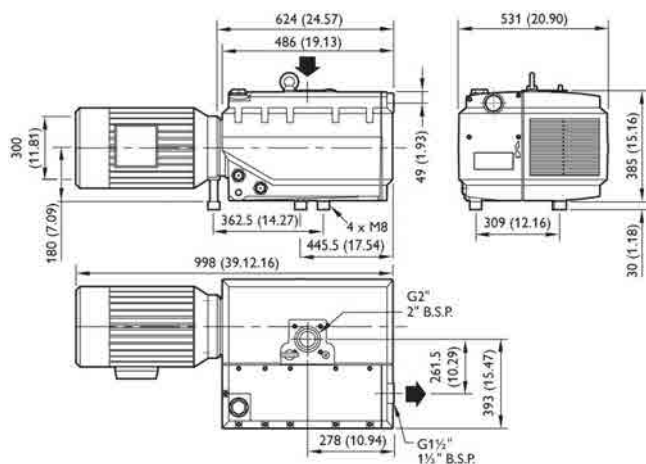

Applications

- Furnaces and metallurgy industries
- Food processing and packaging
- Lifting
- Vacuum coating
- Vacuum transporting

Performance Curves

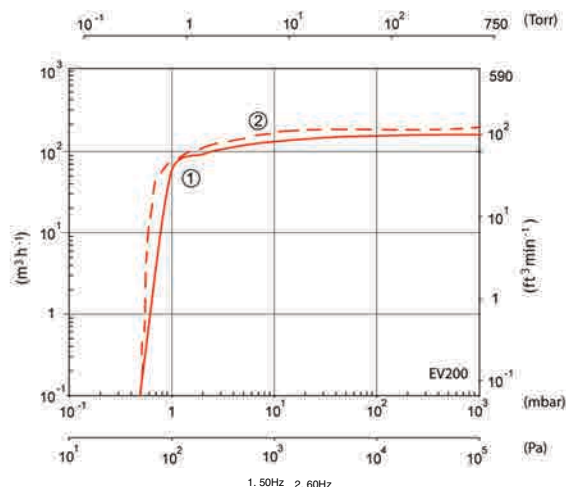

Technical Data

Pumping speed 50 Hz	184 m ³ h ⁻¹ / 111 ft ³ min ⁻¹
Pumping speed 60 Hz	221 m ³ h ⁻¹ / 133 ft ³ min ⁻¹
Ultimate pressure without gas ballast	0.5 mbar
Water vapour capacity	1.33 kg h ⁻¹ @ 10 mbar / 2.9 lb h ⁻¹ @ 10 mbar
Electricity supply 50 Hz	340-430V / 588-745V or 200V
Electricity supply 60 Hz	340-500V / 590-865V or 200V
Motor Power 50 Hz	5.5 kW / 7.5 hp
Motor Power 60 Hz	6.4 kW / 8.5 hp
Noise 50 Hz	73 dB(A)
Noise 60 Hz	76 dB(A)
Weight	163 kg / 359 lbs
Oil capacity	7 litre / 1.84 US gal
Oil Type	UG20

Ordering Information

Product Description	Order No.
EV200 200V, 50/60Hz	A35035934
EV200 340-430/588-745V, 50Hz, 340-500/590-865V, 60Hz	A35035940

EV300 Rotary vane pump



The EV rotary vane pumps are designed to be used in a wide range of industrial and scientific applications. They can be used individually or with mechanical booster pumps to increase both performance and ultimate vacuum. They can operate continuously from atmosphere to ultimate.

With reliability and ease of service in mind, the EV range of pumps are designed for the industrial and scientific markets. Edwards Applications Specialists have unrivalled knowledge and can advise on pump selection, configuration and operation to suit any customers' requirements. The EV range can be supplied individually or as part of pre-engineered combinations using Edwards EH mechanical boosters.

Features & Benefits

- Continuous operation from atmosphere to ultimate vacuum
- High pumping speed at low pressure
- Gas ballast valve fitted as standard
- Low noise and vibration
- Air cooled

Dimensions

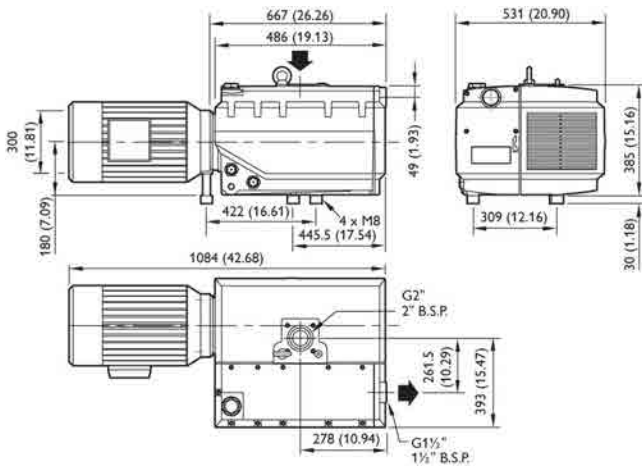

Applications

- Furnaces and metallurgy industries
- Food processing and packaging
- Lifting
- Vacuum coating
- Vacuum transporting

Performance Curves

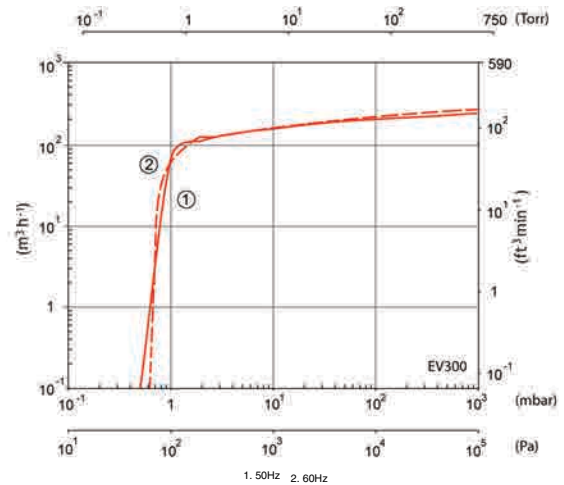

Technical Data

Pumping speed 50 Hz	240 m ³ h ⁻¹ / 145 ft ³ min ⁻¹
Pumping speed 60 Hz	274 m ³ h ⁻¹ / 165 ft ³ min ⁻¹
Ultimate pressure without gas ballast	0.5 mbar
Water vapour capacity	1.4 kg h ⁻¹ @ 10 mbar / 3.1 lb h ⁻¹ @ 10 mbar
Electricity supply 50 Hz	340-430V / 588-745V or 200V
Electricity supply 60 Hz	340-500V / 590-865V or 200V
Motor Power 50 Hz	7.8 kW / 10.5 hp
Motor Power 60 Hz	9.3 kW / 12.5 hp
Noise 50 Hz	73 dB(A)
Noise 60 Hz	76 dB(A)
Weight	178 kg / 392 lbs
Oil capacity	7 litre / 1.84 US gal
Oil Type	UG20

Ordering Information

Product Description	Order No.
EV300 200V, 50/60Hz	A35040934
EV300 340-430/588-745V, 50Hz, 340-500/590-865V, 60Hz	A35040940

EV630 Rotary vane pump



The EV rotary vane pumps are designed to be used in a wide range of industrial and scientific applications. They can be used individually or with mechanical booster pumps to increase both performance and ultimate vacuum. They can operate continuously from atmosphere to ultimate.

With reliability and ease of service in mind, the EV range of pumps are designed for the industrial and scientific markets. Edwards Applications Specialists have unrivalled knowledge and can advise on pump selection, configuration and operation to suit any customers' requirements. The EV range can be supplied individually or as part of pre-engineered combinations using Edwards EH mechanical boosters.

Features & Benefits

- Continuous operation from atmosphere to ultimate vacuum
- High pumping speed at low pressure
- Gas ballast valve fitted as standard
- Low noise and vibration
- Air cooled

Dimensions

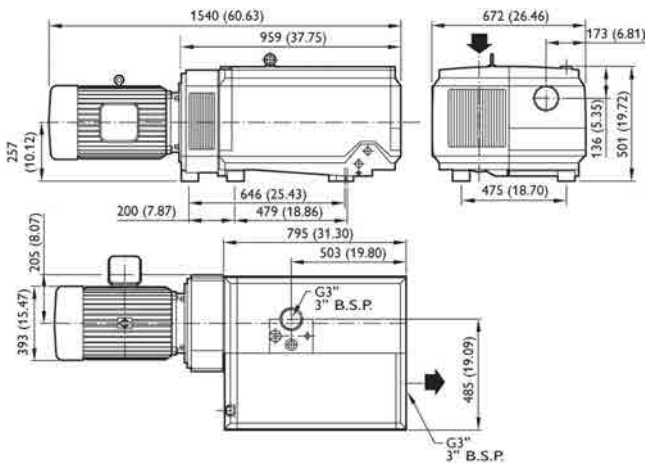

Applications

- Furnaces and metallurgy industries
- Food processing and packaging
- Lifting
- Vacuum coating
- Vacuum transporting

Performance Curves

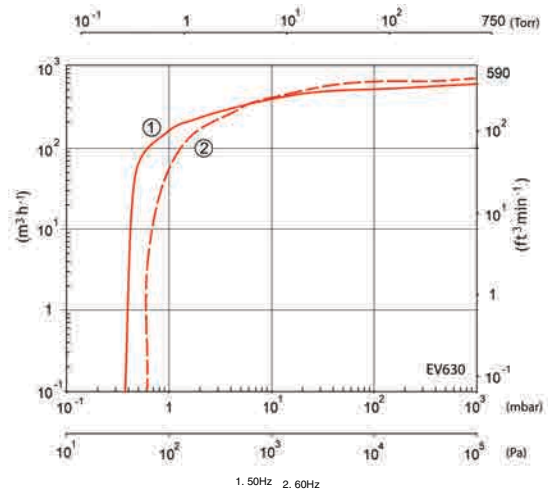

Technical Data

Pumping speed 50 Hz	630 m ³ h ⁻¹ / 380 ft ³ min ⁻¹
Pumping speed 60 Hz	750 m ³ h ⁻¹ / 452 ft ³ min ⁻¹
Ultimate pressure without gas ballast	0.5 mbar
Water vapour capacity	10.4 kg h ⁻¹ @ 4 mbar / 22.9 lb h ⁻¹ @ 4 mbar
Electricity supply 50 Hz	400V / 690V* or 200V
Electricity supply 60 Hz	400V / 690V* or 200V
Motor Power 50 Hz	15 kW / 20 hp
Motor Power 60 Hz	18.5 kW / 25 hp
Noise 50 Hz	80 dB(A)
Noise 60 Hz	83 dB(A)
Weight	525 kg / 1155 lbs
Oil capacity	15 litre / 3.96 US gal
Oil Type	UG20

Ordering Information

Product Description	Order No.
EV630 200V, 50/60Hz	A35050934
EV630 400/690V, 50/60Hz	A35050940

Accessories for Single Stage Oil Sealed Pumps

Oil Level Switch

An oil level switch is available to order as a separate item that can be fitted to give an indication or warning of low oil level in the pump. This allows the user to remotely monitor the oil level and add oil or plan maintenance to prevent potentially serious damage occurring to the pump.

Ordering Information

Product Description	Order No.
Oil level switch EV20, EV40	A35010300
Oil level switch EV70, EV100, EV160, EV200, EV300, EV400, EV630	A35020300

Inlet Filter

A full range of inlet filters for all models are available for use when there is the possibility of harmful dust or debris entering the pump during operation and potentially causing damage or increased wear to the pump mechanism.

Ordering Information

Product Description	Order No.
Inlet filters complete with fittings	
Inlet filter EV20	A35010310
Inlet filter EV40	A35015310
Inlet filter EV70, EV100	A35025310
Inlet filter EV160, EV200, EV300	A35030310
Inlet filter EV400, EV630	A35045310
Spares	Order No.
Inlet filter element EV20	A35010700
Inlet filter element EV40	A35015700
Inlet filter element EV70, EV100	A35025700
Inlet filter element EV160, EV200, EV300	A35030700
Inlet filter element EV400, EV630	A35045700

Spares

Three levels of spares kits are available. Filter kit containing exhaust mist filters, Service kit containing filter kit, seals and blades and an Overhaul kit containing service kit and parts to completely rebuild a pump such as bearings, etc.

Ordering Information

Spares	Order No.
Filter kit EV20 (index A-B)	A35010800
Service kit EV20 (index A)	A35010810
Service kit EV20 (index B)	A35010811
Overhaul kit EV20 (index A)	A35010820
Overhaul kit EV20 (index B)	A35010821
Filter kit EV40	A35015800
Service kit EV40	A35015810
Service kit EV40 (index A)	A35015811
Overhaul kit EV40	A35015820
Overhaul kit EV40 (index A)	A35015821
Filter kit EV70 (index D-G)	A35020801
Service kit EV70 (index D-F)	A35020811
Service kit EV70 (index G)	A35020812
Overhaul kit EV70 (index F)	A35020822
Overhaul kit EV70 (index G)	A35020823
Filter kit EV100 (index D-G)	A35025801
Service kit EV100 (index D-F)	A35025811
Service kit EV100 (index G)	A35025812
Overhaul kit EV100 (index F)	A35025822
Overhaul kit EV100 (index G)	A35025823
Filter kit EV160 (index F)	A35030802
Service kit EV160 (index F)	A35030812
Overhaul kit EV160 (index F)	A35030822
Filter kit EV200 (index E-F)	A35035801
Service kit EV200 (index F)	A35035812
Overhaul kit EV200 (index F)	A35035822
Filter kit EV300 (index E-F)	A35040801
Service kit EV300 (index F)	A35040812
Overhaul kit EV300 (index F)	A35040822
Filter kit EV400 (index A&D)	A35045800
Service kit EV400 (index A&D)	A35045810
Overhaul kit EV400 (index D)	A35045821
Filter kit EV630 (index C-D)	A35050800
Service kit EV630 (index C-D)	A35050810
Overhaul kit EV630 (index C-D)	A35050820

EV Single Stage Oil Sealed Pump Combinations

Our comprehensive range of EV pumps and mechanical boosters, complete with connection kits to mount the mechanical booster allows the user to specify a complete system. The fitting of a mechanical booster to an EV rotary vane pump significantly increases pumping speed and vacuum performance of the system, as well as increasing the ultimate vacuum attainable by approximately one decade of pressure.

Specifying a combination is simply a process of selecting the EV pump, selecting the required mechanical booster (from catalogue) and the appropriate connection kit shown below. The connection kits are supplied as a kit of parts that allows them to be easily assembled, together with the EV pump and mechanical booster on site. Clear and concise instructions are included with the kits to make this a very simple process.

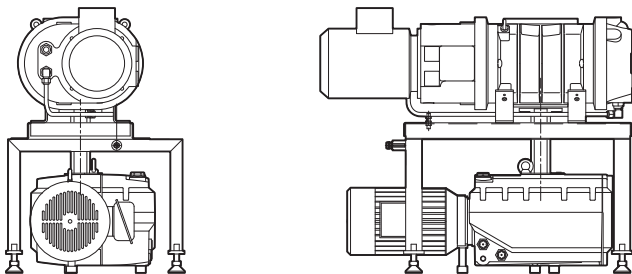

Ordering Information Booster Connections

Primary pump	Booster								
	EH250	EH500	EH1200	607MV05	EH2600	615MV10 61BMV10	EH4200	615MV15 61BMV25	622MV25
EV100	NR7001000	NR7002000	NR7003000	NR7046000					
EV160		NR7006000	NR7007000	NR7047000		NR7050000			
EV200		NR7010000	NR7011000			NR7050000			
EV300		NR7014000	NR7015000		NR7016000	NR7050000	NR7017000	NR7050000	
EV400			NR7021000		NR7022000	NR7056000	NR7023000	NR7056000	
EV630			NR7028000		NR7029000	NR7056000	NR7030000	NR7056000	NR7064000

To ensure that both pumps and connecting kits are ordered:

Select the required EV pump – order as individual item

Select the required mechanical booster – order as individual item

Select the connection kit required to mount the booster on the EV pump from the table above – order as individual item

The three components will be supplied packed individually for assembly on receipt. The mounting kit contains simple instructions detailing the operations required to assemble the mounting kit and how to connect both the EV and mechanical booster together as a system.

EH Mechanical Booster Pumps



The EH mechanical booster pumps feature the unique hydrokinetic drive, providing an efficient power transmission with benefits in economy, performance and compactness. The hydrokinetic drive provides the following features:

- Pump down times cut by 50%, when compared with direct drive pumps
- No bypass lines or pressure switches required
- Universal voltage motors
- Reduced capital and operating costs
- Air cooled motors – with water cooled options
- Quiet, minimum vibration

The EH mechanical booster pumps, based on the simple Roots principle, remain the favorite pumps for applications where high pumping speeds over $3000 \text{ m}^3\text{h}^{-1} / 1776 \text{ ft}^3\text{min}^{-1}$ are required in the pressure region of 0.01 to 50 mbar / 0.0075 to 37.5 Torr. These pumps must always be backed by another pump which can deliver against a high pressure differential to atmospheric pressure.

Operating at relatively low pressures, the mechanical booster pump is not exposed to the same concentrations of corrosive process media as is the backing pump, which makes it highly reliable.

High Performance Pumping Mechanism

The EH has a high quality, oil-free pumping mechanism. This offers:

- Quiet, vibration free operation
- Rugged and corrosion resistant
- Advanced shaft-seal technology – no oil contamination of process chamber

The corrosion resistant pumping mechanism is manufactured from high grade cast iron. The proven shaft-seal arrangement ensures that no oil enters the pumping stator, and the absence of internal and external by-pass lines and valves which may corrode or stick minimizes maintenance requirements.

The design of the shaft seals is optimised to ensure that no lubricants can migrate into the pumping mechanism. This maintains booster pump performance in applications which demand the highest standard of cleanliness. In addition, this prevents the build-up of trapped particles on the rotor lobes and end-faces which have very close tolerances.

The dynamically balanced rotors and precision ground gears contribute to the smooth, quiet operation of the pumps, as demanded by manufacturers of advanced technology equipment.

Broad Application Coverage

EH mechanical boosters are available to cover a broad range of industrial and chemical process applications.

Industrial

Industrial EH boosters are safe to handle non-flammable gases and vapours within the normal operating parameters of the booster.

ATEX

ATEX classified EH boosters are annotated with the suffix "T3" or "T160".

- EH boosters may be supplied with ATEX classification either as part of a pump system or stand-alone, on application. Please consult Edwards.
- ATEX compliance is typically specified for use in Europe, but may also be required in other areas.

ATEX compliant EH boosters are suitable for operation in ATEX systems rated as follows:

All of the EH1200C, EH1200 T160, EH2600C, EH2600 T3, EH2600 T160, EH4200C, EH4200 T3 and EH4200 T160 chemical EH pumps are fitted with flameproof motors:

- Pumps suitable for 50 Hz operation are fitted with a flameproof motor approved to EEx d. Gas Group IIA, IIB, Temperature Class T4.
- Pumps suitable for 60 Hz operation are fitted with a flameproof motor approved to CSA, Division 1 area, Gas Class I Group C & D, and Dust Class II Group F & G, Temperature Class T3C.

Internal and External Classifications

II 2G c IIB T3

or

II 2G c IIB T160

The notations used in these ratings are as follows:

Symbol	Meaning
	Specifies that the chemical EH pump can be used in a potentially explosive atmosphere
II	Equipment group II
2 G	Equipment category 2 (gas)
c	Constructional safety
IIB	Suitable to pump gas group IIB
T3 / T160	Gas auto-ignition temperature

Equipment Category

For equipment category 1 (gas) consult Edwards.

Gas Auto-Ignition Temperature

The temperature classifications applied to the chemical EH pumps relate to the auto-ignition temperature of flammable materials that can be pumped:

- The EH1200C, EH2600C, EH4200C and chemical EH pumps that have a T3 classification are suitable for pumping flammable materials that have an auto-ignition temperature greater than 200 °C.
- Chemical EH pumps that have a T160 classification are suitable for pumping flammable materials that have an auto-ignition temperature greater than 160 °C.

Explosion Proof

Explosion proof boosters are annotated with the suffix "C".

- EH boosters may be ordered with explosion proof motors either individually, or as part of an explosion proof system.
- Explosion proof is generally applicable in N. America and the rest of the world (excluding Europe).

Explosion-proof boosters will be supplied fitted with an explosion-proof motor (suitable for 60 Hz operation) approved to CSA, Division 1 area, Gas Class I Group C & D and Dust Class II Group F & G, Temperature Class T3C.

EH Pumps with Hydrokinetic Drive

EH booster pumps have a unique and patented hydrokinetic fluid drive, which couples the motor to the pumping mechanism. The hydrokinetic drive offers the following advantages:

- Pump down times cut by up to 50%
- Reduced capital and operating costs
- No pressure sensors, by-pass lines or valves
- Can operate continuously at all pressures – when used with a backing pump

EH booster pumps have universal voltage, air-cooled motors and are available with effective pumping speeds of up to 4140 m³h⁻¹ / 2440 ft³min⁻¹. The pump bodies of the EH1200, EH2600 and EH4200 pumps are water-cooled.

Two versions of each EH booster pump are available, with different oils used for the lubrication of the seals and gears. The standard version uses mineral oils, such as Ultragrade 20. The alternative version has PFPE (perfluoropolyether) oils and is suitable for applications where oxygen or other reactive and corrosive gases are processed.

Pump-Down Times cut by up to 50% The hydrokinetic drive allows the booster pump to be started at the same time as the backing pump (at atmospheric pressure) as it prevents motor overload. The EH booster pump therefore assists the pumping process from the start of pump-down. In comparison pumping systems with conventional, direct drive mechanical booster pumps (where the booster pump is switched on when the chamber pressure has been reduced to, typically, less than 10 mbar / 7.5 Torr), the total evacuation time can be reduced by as much as 50%. The graph below shows data for a 2.8 m³ / 100 ft³ chamber, with a 2600 m³h⁻¹ / 2600 ft³min⁻¹ mechanical booster pump and a 255 m³h⁻¹ / 150 ft³min⁻¹ backing pump.

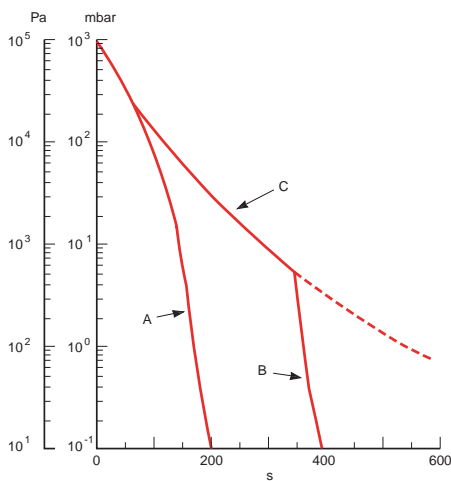

- A With backing pump and EH mechanical booster pump switched on together
- B With mechanical booster pump switched on at 5 mbar
- C With backing pump only (pumping through booster pump)

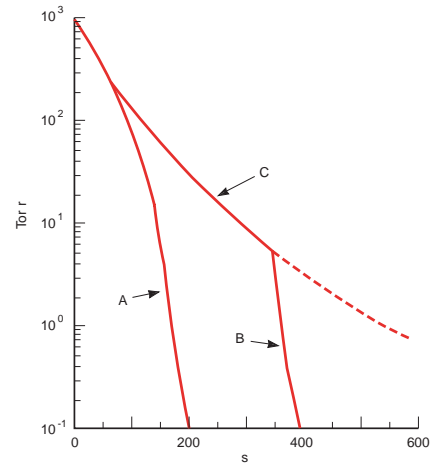

- A With backing pump and EH mechanical booster pump switched on together
- B With mechanical booster pump switched on at 5 mbar
- C With backing pump only (pumping through booster pump)

Automatic Overload Protection The hydrokinetic drive automatically varies the rotational speed of the pump. This protects the motor from overload, prevents over-heating, and allows the pump to operate with high pressure differentials. Consequently, EH booster pumps are not damaged by sudden increases of inlet pressure and even by the entry of solid debris into the pump.

Important Cost Savings When you use EH mechanical booster pumps, you save money on installation and operation. Your capital costs are reduced as you do not need valves, by-pass lines and pressure switches, and you can use a smaller backing pump than with conventional drive booster pumps. Operation costs are reduced because EH booster pumps have smaller motors than direct drive pumps and, when operating at full speed, they use only a fraction of the rated power.

EH250 Mechanical Booster Pump

The EH mechanical booster pump, based on the simple Roots principle, remains the favourite pump for applications where high pumping speeds are required for pressures in the region of 0.01 to 10 mbar. This pump must always be backed by another pump, which can deliver against a high-pressure differential to atmospheric pressure.

Operating at relatively low pressures, the mechanical booster pump is not exposed to the same concentrations of corrosive process media as is the backing pump, which makes it highly reliable.



Features & Benefits

- Suitable for applications where high pumping speeds over 3000 $\text{m}^3 \text{h}^{-1}$ / 1776 $\text{ft}^3 \text{min}^{-1}$ are required in the pressure region of 0.01 to 50 mbar/0.0075 to 37.5 Torr.
- Operating at relatively low pressures makes it highly reliable.
- The EH pumps have a high quality, oil-free pumping mechanism. This offers:
 - Quiet, vibration free operation.
 - Rugged and corrosion resistant.

Dimensions

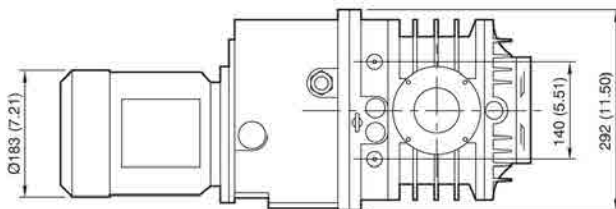
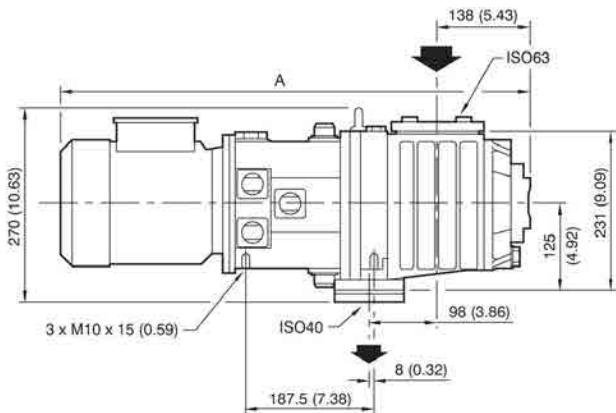

Model	A (mm)
EH250	709
EH500	797
EH1200/EH1200IND	953
EH2600	1150
EH2600 IND	1289
EH4200	1330
EH4200IND	1469

Pump is shown with inlet and outlet blanking flanges fitted. Dimensions are to the top surface of the pump flange.

Applications

- Semiconductor processing
- Vacuum distillation
- Vacuum packaging
- Steel de-gassing
- Thin film coating

Performance Curves

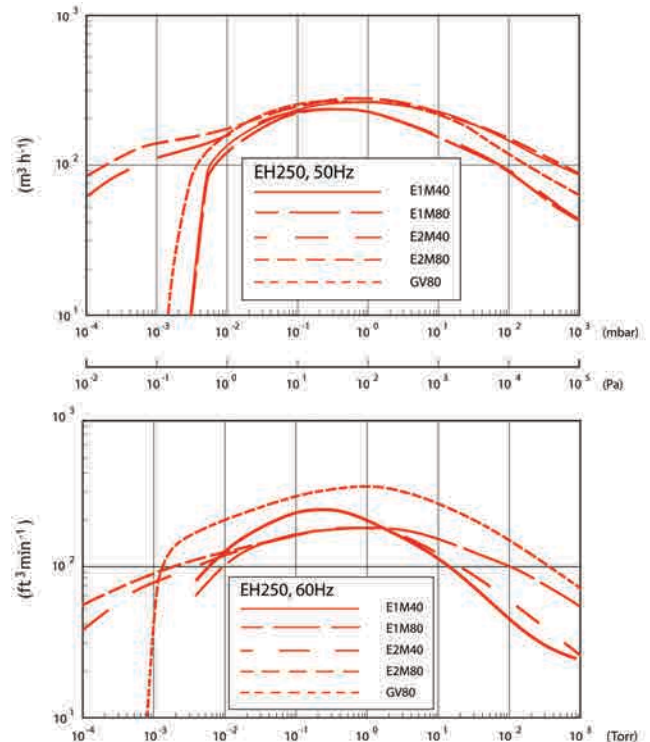

Technical Data

Displacement (swept volume)	
50Hz	310 m ³ h ⁻¹ / 185 ft ³ min ⁻¹
60Hz	375 m ³ h ⁻¹ / 220 ft ³ min ⁻¹
Effective pumping speed with backing pump	
E1M40 or E2M40	240 m ³ h ⁻¹ / 141 ft ³ min ⁻¹
E1M80 or E2M80	274 m ³ h ⁻¹ / 161 ft ³ min ⁻¹
Pressure differential across pump	
50Hz	0-180 mbar / 0-140 Torr
60Hz	0-150 mbar / 0-115 Torr
Inlet connection	ISO63
Outlet connection	ISO40
Rotational speed ‡	
50Hz	0-2900 rpm
60Hz	0-3500 rpm
Operating continuous inlet pressure	0-1000 mbar / 0-760 Torr
Maximum outlet pressure	1000 mbar / 760 Torr
Recommended backing pumps	GV80, E1M/E2M40, E1M/E2M80
Electrical supply voltage, 3-ph	
50Hz	220 – 240V / 380 – 415V
60Hz	208-230V / 460V
Motor power	
Hydrocarbon	2.2 kW / 3 hp
PFPE	1.5 kW / 2 hp
ATEX	2.2 kW
Explosion proof	3 hp
Ambient temperature range	
Operating	5 to 40°C / 40 to 104°F
Storage	-10 to 80°C / 14 to 176°F
Maximum operating humidity	90% RH
Recommended oil	Ultragrade 20
Oil capacity	
Coupling cover	1.5 litre / 1.6 qt
Shaft seal reservoir	0.125 litre / 0.25 qt
Weight*	66 kg / 142 lb

*Weight refers to IND version

Ordering Information

Product Description	Order No.
EH250IND 200V, 3-ph, 60Hz, 3hp	NRC221000
EH250IND 200V, 3-ph, 50Hz, 2.2kW	NRC222000
EH250IND 220-240/380-415V, 3-ph, 50Hz, 2.2kW	A30151945
EH250IND 208 – 230V or 460V, 3-ph, 60Hz, 3 hp	A30152946
PFPE EH250FX 220-240/380-415V, 3-ph, 50Hz, 1.5kW	A30153935
PFPE EH250FX 208-230/460V, 3-ph, 60Hz, 2 hp	A30154936
EH250C 460V, 3-ph 60Hz, 3 hp	NRA997000
EH250T160 220-240/380-415V, 3-ph 50Hz, 2.2kW	NRA996000
Accessories & Spares	Order No.
Spares Kit Con C&O EH/QMB250/500A	A30151815
Spares Kit Module EH/QMB250/500A	A30151820
Spares Kit Shim EH/QMB250/500A	A30151825
Inlet Mesh Assy 3.3 mm ISO63	A60041029
ISO63 Screen Centring S/S Viton	C10521085

EH500 Mechanical booster pump

The EH mechanical booster pump, based on the simple Roots principle, remains the favourite pump for applications where high pumping speeds are required for pressures in the region of 0.01 to 10 mbar. This pump must always be backed by another pump, which can deliver against a high-pressure differential to atmospheric pressure.

Operating at relatively low pressures, the mechanical booster pump is not exposed to the same concentrations of corrosive process media as is the backing pump, which makes it highly reliable.



Features & Benefits

- Suitable for applications where high pumping speeds over 3000 $\text{m}^3 \text{h}^{-1}$ / 1776 $\text{ft}^3 \text{min}^{-1}$ are required in the pressure region of 0.01 to 50 mbar/0.0075 to 37.5 Torr.
- Operating at relatively low pressures makes it highly reliable.
- The EH pumps have a high quality, oil-free pumping mechanism. This offers:
 - Quiet, vibration free operation.
 - Rugged and corrosion resistant.

Dimensions

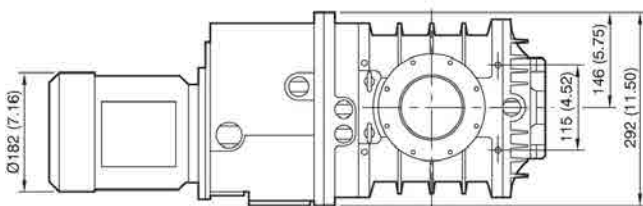
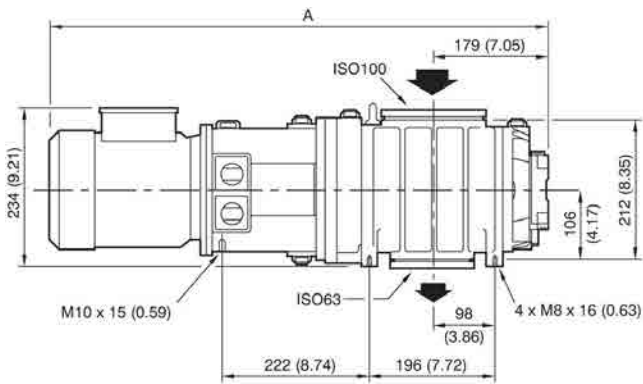

	A (mm)
EH250	709
EH500	797
EH1200/EH1200IND	953
EH2600	1150
EH2600 IND	1289
EH4200	1330
EH4200IND	1469

Pump is shown with inlet and outlet blanking flanges fitted. Dimensions are to the top surface of the pump flange.

Applications

- Semiconductor processing
- Vacuum distillation
- Vacuum packaging
- Steel de-gassing
- Thin film coating

Performance Curves

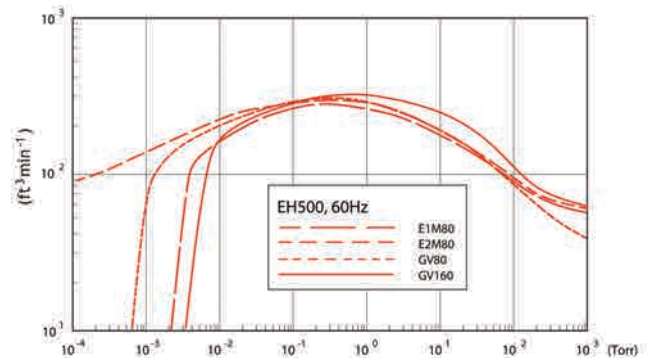
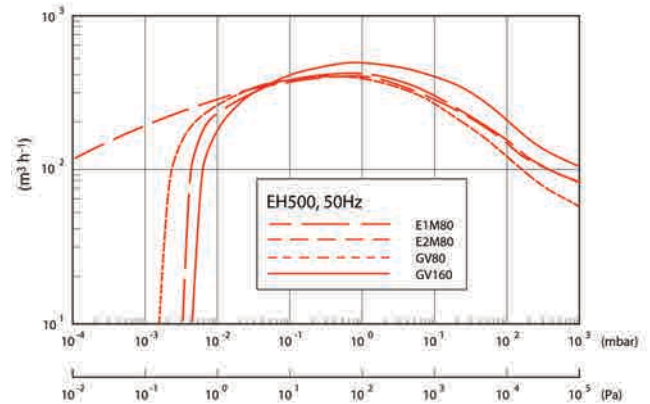

Technical Data

Displacement (swept volume)	
50Hz	505 m ³ h ⁻¹ / 300 ft ³ min ⁻¹
60Hz	605 m ³ h ⁻¹ / 335 ft ³ min ⁻¹
Effective pumping speed with backing pump	
E1M40 or E2M40	350 m ³ h ⁻¹ / 206 ft ³ min ⁻¹
E1M80 or E2M80	400 m ³ h ⁻¹ / 236 ft ³ min ⁻¹
E1M175 or E2M175	440 m ³ h ⁻¹ / 259 ft ³ min ⁻¹
E1M275 or E2M275	460 m ³ h ⁻¹ / 271 ft ³ min ⁻¹
Pressure differential across pump †	
50Hz	0-110 mbar / 0-83 Torr
60Hz	0-90 mbar / 0-68 Torr
Inlet connection	ISO100
Outlet connection	ISO63
Rotational speed	
50Hz	0-2900 rpm
60Hz	0-3500 rpm
Operating continuous inlet pressure	0-1000 mbar / 0-760 Torr
Maximum outlet pressure	1000 mbar / 760 Torr
Recommended backing pumps	GV80, E2M80
Electrical supply	
50Hz	220-240V / 380-415V
60Hz	208-230V / 460V
Motor power	
Hydrocarbon	2.2kW / 3hp
PFPE	1.5 kW / 2hp
ATEX	2.2kW
Explosion proof	3hp
Ambient temperature range	
Operating	5 to 40°C / 40 to 104°F
Storage	-10 to 80°C / 14 to 176°F
Maximum operating humidity	90% RH
Recommended oil	
Standard version	Ultragrade 20
PFPE version	Fomblin® YVAC 16/6
Oil capacity	
Coupling cover	1.5 litre / 1.6 qt
Shaft seal reservoir	0.125 litre / 0.25 qt
Weight*	74 kg / 163 lb

*Weight refers to IND version

Ordering Information

Product Description	Order No.
EH500IND 208-230/460V, 3-ph, 60Hz, 3 hp	A30272946
EH500IND 200V, 3-ph 60Hz, 3 hp	NRC219000
EH500IND 200V, 3-ph, 50Hz, 2.2kW	NRC220000
EH500IND 220-240/380-415V, 3-ph, 50Hz, 2.2kW	A30271945
EH500AFX 220-240/380-415V, 3-ph 50Hz, 1.5 kW	A30273935
EH500AFX 208-230/460V, 3-ph, 60Hz, 2 hp	A30274936
EH500C 460V, 3-ph, 60Hz, 3 hp	NRA999000
EH500T3 220-240/380-415V, 3-ph, 50Hz, 2.2kW	NRA998000
Accessories & Spares	Order No.
Spares Kit Con C&O EH/QMB250/500A	A30151815
Spares Kit Module EH/QMB250/500A	A30151820
Spares Kit Shim EH/QMB250/500A	A30151825
ISO100 Screen Centring S/S Viton	C10523085
Inlet Mesh Assembly EH250/EH500A	A60041569

EH1200 Mechanical booster pump

The EH mechanical booster pump, based on the simple Roots principle, remains the favourite pump for applications where high pumping speeds are required for pressures in the region of 0.01 to 10 mbar. This pump must always be backed by another pump, which can deliver against a high-pressure differential to atmospheric pressure.

Operating at relatively low pressures, the mechanical booster pump is not exposed to the same concentrations of corrosive process media as is the backing pump, which makes it highly reliable.



Features & Benefits

- Suitable for applications where high pumping speeds over 3000 $\text{m}^3 \text{h}^{-1}$ / 1776 $\text{ft}^3 \text{min}^{-1}$ are required in the pressure region of 0.01 to 50 mbar/0.0075 to 37.5 Torr.
- Operating at relatively low pressures makes it highly reliable.
- The EH pumps have a high quality, oil-free pumping mechanism. This offers:
 - Quiet, vibration free operation.
 - Rugged and corrosion resistant.

Dimensions

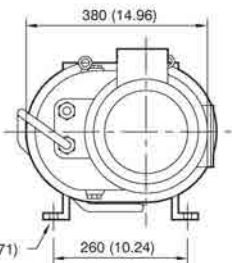
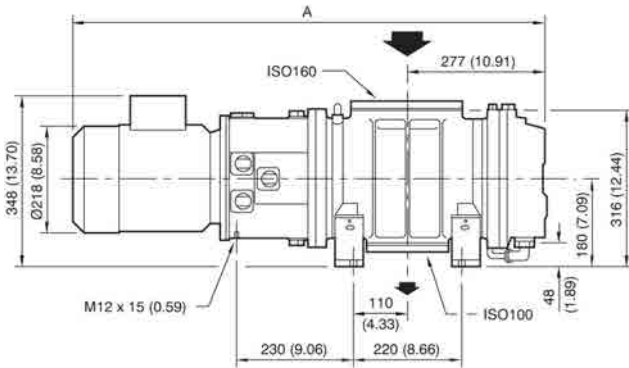

A (mm)	Model
709	EH250
797	EH500
953	EH1200/EH1200IND
1150	EH2600
1289	EH2600 IND
1330	EH4200
1469	EH4200IND

Pump is shown with inlet and outlet blanking flanges fitted. Dimensions are to the top surface of the pump flange.

Applications

- Semiconductor processing
- Vacuum distillation
- Vacuum packaging
- Steel de-gassing
- Thin film coating

Performance Curves

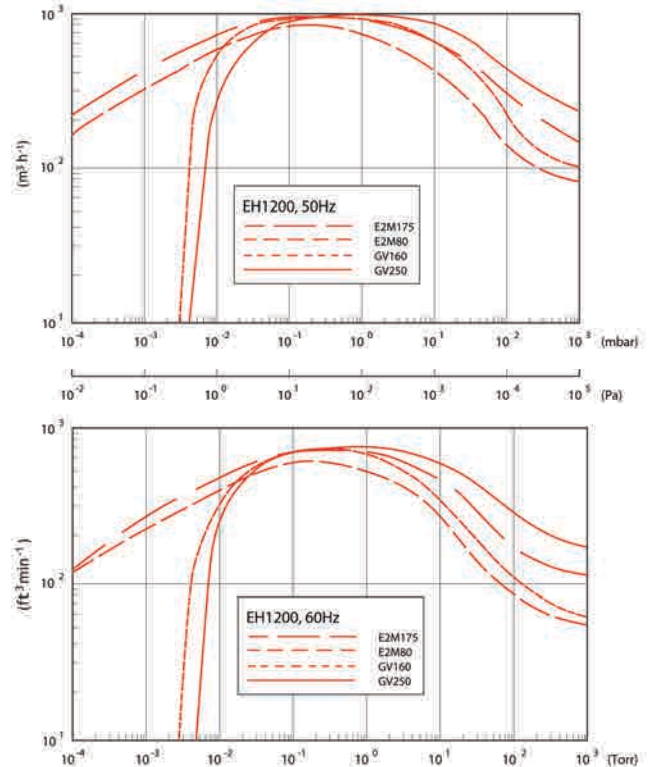

Technical Data

Displacement (swept volume)	
50Hz	1195 m ³ h ⁻¹ / 715 ft ³ min ⁻¹
60Hz	1435 m ³ h ⁻¹ / 845 ft ³ min ⁻¹
Effective pumping speed with backing pump	
E2M80	840 m ³ h ⁻¹ / 495 ft ³ min ⁻¹
E2M175	930 m ³ h ⁻¹ / 548 ft ³ min ⁻¹
E2M275	1020 m ³ h ⁻¹ / 601 ft ³ min ⁻¹
Pressure differential across pump †	
50Hz	0-90 mbar / 0-68 Torr
60Hz	0-75 mbar / 0-56 Torr
Inlet connection	ISO160
Outlet connection	ISO100
Rotational speed	
50Hz	0-2900 rpm
60Hz	0-3500 rpm
Operating continuous inlet pressure	0-1000 mbar / 0-760 Torr
Maximum outlet pressure	1000 mbar / 760 Torr
Recommended backing pumps	GV160, GV250, E2M80, E2M175
Electrical supply	
50Hz	220-240V / 380-415V
60Hz	208-230V / 460V
Motor power	
Hydrocarbon	3kW / 4hp
PFPE	3kW / 4hp
ATEX	3kW
Explosion proof	4hp
Ambient temperature range	
Operating	5 to 40°C / 40 to 104°F
Storage	-10 to 80°C / 14 to 176°F
Maximum operating humidity	90% RH
Recommended cooling water flow (inlet temperature 20°C)*	120lh ⁻¹ / 0.53 gal min ⁻¹
Recommended cooling water supply pressure*	2-6 bar
Cooling water connections*	3/8 inch BSP male
Recommended oil	
Standard version	Ultragrade 20
PFPE version	Fomblin® YVAC 16/6
Oil capacity	
Gear case	1.25 litre / 1.3 qt
Coupling cover	1.5 litre / 1.6 qt
Shaft seal reservoir	0.125 litre / 0.25 qt
Weight**	149 kg / 327.8 lb

* Under many circumstances, pumps may operate without cooling water. Apply to Edwards for more information.

** Weight refers to IND version

†. Depends on pressure

Ordering Information

Product Description	Order No.
EH1200IND 220-240/380-415V, 3-ph, 50Hz, 3kW	A30590935
EH1200IND 208-230/460V, 3-ph, 60Hz, 4 hp	A30591936
EH1200IND 200V, 3-ph, 60Hz, 4 hp	NRC217000
EH1200IND 200V, 3-ph, 50Hz, 3 kW	NRC218000
EH1200FX 220-240/380-415V, 3-ph, 50Hz, 3 kW	A30592935
EH1200FX 208-230/460V, 3-ph, 60Hz, 4 hp	A30593936
EH1200C 230/460V, 3-ph, 60Hz, 4 hp	A30556982
EH1200T160 380-415V, 3-ph, 50Hz, 3kW	A30557900
Accessories & Spares	Order No.
Spares Kit Con C&O EH/QMB1200	A30551815
Spares Kit Module EH/QMB1200	A30551820
Shim kit	A30551825
ISO160 Screen Centring S/S Viton	C10524085
Inlet Mesh Assembly EH2600/EH4200	A60041570

EH2600 Mechanical booster pump

The EH mechanical booster pump, based on the simple Roots principle, remains the favourite pump for applications where high pumping speeds are required for pressures in the region of 0.01 to 10 mbar. This pump must always be backed by another pump, which can deliver against a high-pressure differential to atmospheric pressure.

Operating at relatively low pressures, the mechanical booster pump is not exposed to the same concentrations of corrosive process media as is the backing pump, which makes it highly reliable.



Features & Benefits

- Suitable for applications where high pumping speeds over $3000 \text{ m}^3 \text{ h}^{-1} / 1776 \text{ ft}^3 \text{ min}^{-1}$ are required in the pressure region of 0.01 to 50 mbar/0.0075 to 37.5 Torr.
- Operating at relatively low pressures makes it highly reliable.
- The EH pumps have a high quality, oil-free pumping mechanism. This offers:
 - Quiet, vibration free operation.
 - Rugged and corrosion resistant.

Dimensions

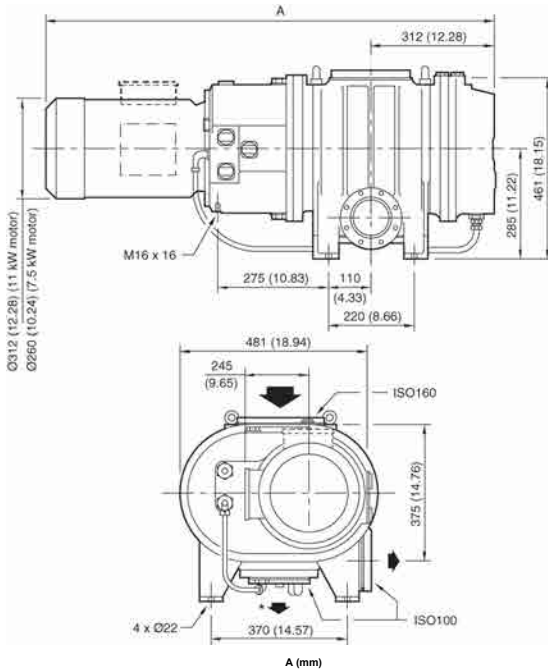

Model	A (mm)
EH250	709
EH500	797
EH1200/EH1200IND	953
EH2600	1150
EH2600 IND	1289
EH4200	1330
EH4200IND	1469

Pump is shown with inlet and outlet blanking flanges fitted. Dimensions are to the top surface of the pump flange.

* Alternative outlet position

Applications

- Semiconductor processing
- Vacuum distillation
- Vacuum packaging
- Steel de-gassing
- Thin film coating

Performance Curves

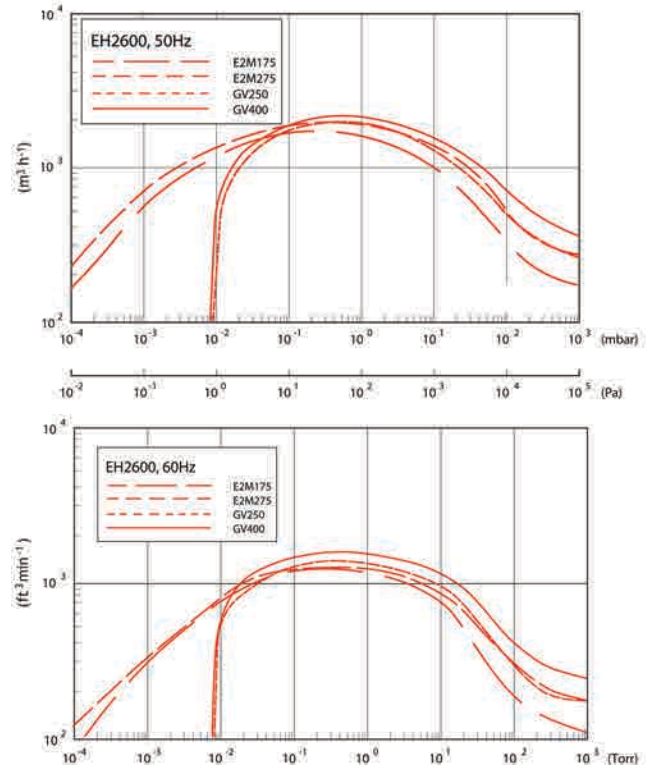

Technical Data

Displacement (swept volume)	
50Hz	2590 m ³ h ⁻¹ / 1525 ft ³ min ⁻¹
60Hz	3110 m ³ h ⁻¹ / 1830 ft ³ min ⁻¹
Effective pumping speed with backing pump	
E2M175	1750 m ³ h ⁻¹ / 1031 ft ³ min ⁻¹
E2M275	1900 m ³ h ⁻¹ / 1119 ft ³ min ⁻¹
Pressure differential across pump †	
50Hz	0-80 mbar / 0-60 Torr
60Hz	0-67 mbar / 0-50 Torr
Inlet connection	ISO160
Outlet connection	ISO100
Rotational speed	
50Hz	0-2900 rpm
60Hz	0-3500 rpm
Operating continuous inlet pressure	0-1000 mbar / 0-760 Torr
Maximum outlet pressure	1000 mbar / 760 Torr
Recommended backing pumps	GV250, GV400, E2M175, E2M275
Electrical supply	
50Hz	220-240V / 380-415V
60Hz	208-230V / 460V
Motor power	
Hydrocarbon	11kW / 15hp
PFPE	7.5kW / 10hp
ATEX	11kW
Explosion proof	15hp
Ambient temperature range	
Operating	5 to 40°C / 40 to 104°F
Storage	-10 to 80°C / 14 to 176°F
Maximum operating humidity	90% RH
Recommended cooling water flow (inlet temperature 20°C)*	250lh ⁻¹ / 1.1 gal min ⁻¹
Recommended cooling water supply pressure*	2-6 bar
Cooling water connections*	3/8 inch BSP male
Recommended oil	
Standard version	Ultragrade 20
PFPE version	Fomblin® YVAC 16/6
Oil capacity	
Gear case	3.5 litre / 3.3 qt
Coupling cover	6.5 litre / 7 qt
Shaft seal reservoir	1.5 litre / 1.4 qt
Weight**	345 kg / 759 lb

* Under many circumstances, pumps may operate without cooling water. Apply to Edwards for more information.

** Weight refers to IND version

†. Depends on pressure

Ordering Information

Product Description	Order No.
EH2600IND 380-415V, 3-ph, 50Hz, 11 kW	A30775946
EH2600IND 230/460V, 3-ph, 60Hz, 15 hp	A30776982
EH2600IND 200V, 3-ph, 60Hz, 15 hp	NRB989000
EH2600IND 200V, 3-ph, 50Hz, 11 kW	NRC216000
EH2600FX 220-240/380-415V, 3-ph, 50Hz, 7.5kW	A30753935
EH2600FX 208-230/460V, 3-ph, 60Hz, 10 hp	A30754936
EH2600C 230/460V, 3-ph, 60Hz, 15 hp	A30756982
EH2600T3 380-415V, 3-ph, 50Hz, 11 kW	A30741935
EH2600T160 380-415V, 3-ph, 50Hz, 11 kW	A30779900
Accessories & Spares	Order No.
Spares Kit Con C&O EH/QMB26/4200	A30751815
Spares Kit Module EH/QMB26/4200	A30751820
Spares Kit Shim EH/QMB12/26/4200	A30751825
ISO160 Screen Centring S/S Viton	C10524085
Inlet Mesh Assembly EH2600/EH4200	A60041570

EH4200 Mechanical booster pump

The EH mechanical booster pump, based on the simple Roots principle, remains the favourite pump for applications where high pumping speeds are required for pressures in the region of 0.01 to 10 mbar. This pump must always be backed by another pump, which can deliver against a high-pressure differential to atmospheric pressure.

Operating at relatively low pressures, the mechanical booster pump is not exposed to the same concentrations of corrosive process media as is the backing pump, which makes it highly reliable.



Features & Benefits

- Suitable for applications where high pumping speeds over 3000 $\text{m}^3 \text{h}^{-1}$ / 1776 $\text{ft}^3 \text{min}^{-1}$ are required in the pressure region of 0.01 to 50 mbar/0.0075 to 37.5 Torr.
- Operating at relatively low pressures makes it highly reliable.
- The EH pumps have a high quality, oil-free pumping mechanism. This offers:
 - Quiet, vibration free operation.
 - Rugged and corrosion resistant.

Applications

- Semiconductor processing
- Vacuum distillation
- Vacuum packaging
- Steel de-gassing
- Thin film coating

Dimensions

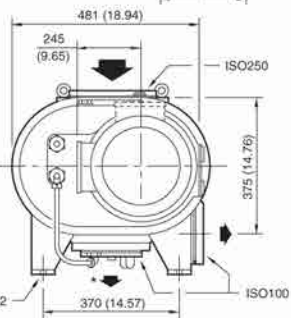
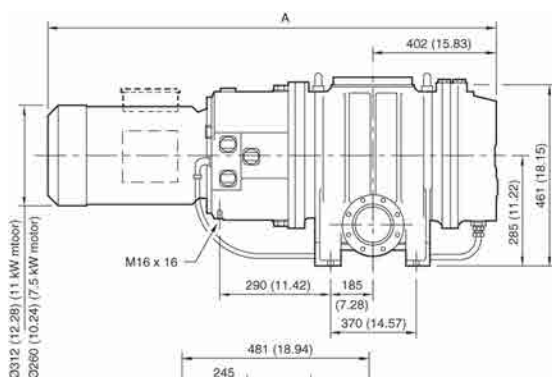

A (mm)	Model
709	EH250
797	EH500
953	EH1200/EH1200IND
1150	EH2600
1289	EH2600 IND
1330	EH4200
1469	EH4200IND

Pump is shown with inlet and outlet blanking flanges fitted. Dimensions are to the top surface of the pump flange.

* Alternative outlet position

Performance Curves

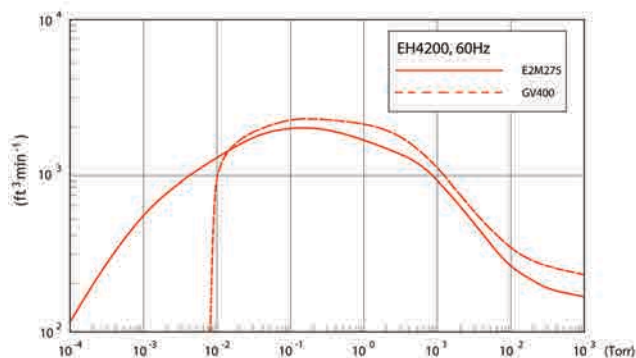
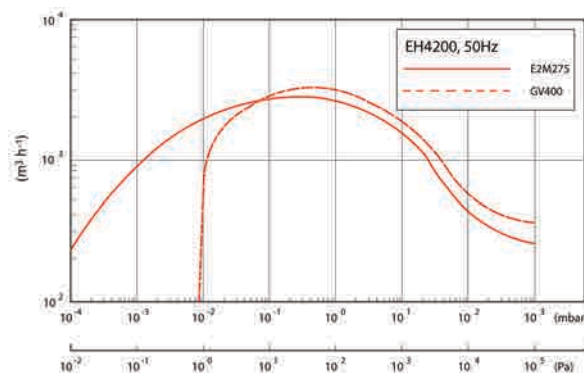

Technical Data

Displacement (swept volume)	
50Hz	4140 m ³ h ⁻¹ / 2440 ft ³ min ⁻¹
60Hz	4985 m ³ h ⁻¹ / 2935 ft ³ min ⁻¹
Effective pumping speed with backing pump	
E2M275	3100 m ³ h ⁻¹ / 1825 ft ³ min ⁻¹
Pressure differential across pump †	
50Hz	0-60 mbar / 0-45 Torr
60Hz	0-50 mbar / 0-38 Torr
Inlet connection	ISO250
Outlet connection	ISO100
Rotational speed	
50Hz	0-2900 rpm
60Hz	0-3500 rpm
Operating continuous inlet pressure	0-1000 mbar / 0-760 Torr
Maximum outlet pressure	1000 mbar / 760 Torr
Recommended backing pumps	GV400, E2M275
Electrical supply	
50Hz	220-240V / 380-415V
60Hz	208-230V / 460V
Motor power	
Hydrocarbon	11kW / 15hp
PFPE	11kW / 15hp
ATEX	11kW
Explosion proof	15hp
Ambient temperature range	
Operating	5 to 40°C / 40 to 104°F
Storage	-10 to 80°C / 14 to 176°F
Maximum operating humidity	90% RH
Recommended cooling water flow (inlet temperature 20°C)*	250lh ⁻¹ / 1.1 gal min ⁻¹
Recommended cooling water supply pressure*	2-6 bar
Cooling water connections*	3/8 inch BSP male
Recommended oil	
Standard version	Ultragrade 20
PFPE version	Fomblin® YVAC 16/6
Oil capacity	
Gear case	3.5 litre / 3.3 qt
Coupling cover	6.5 litre / 7 qt
Shaft seal reservoir	1.5 litre / 1.4 qt
Weight**	380 kg / 836 lb

* Under many circumstances, pumps may operate without cooling water. Apply to Edwards for more information.

** Weight refers to IND version

†. Depends on pressure

Ordering Information

Product Description	Order No.
EH4200IND 380-415V, 3-ph, 50Hz, 11kW	A30975946
EH4200IND 200V, 3-ph, 60Hz, 15 hp	NRB988000
EH4200IND 200V, 3-ph, 50Hz, 11 kW	NRC215000
EH4200IND 208-230/460V, 3-ph, 60Hz, 15 hp	A30976982
EH4200C 230/460V, 3-ph, 60Hz, 15 hp	A30956982
EH4200T3 380-415V, 3-ph, 50Hz, 11 kW	A30941935
EH4200T160 380-415V, 3-ph, 50Hz, 11 kW	A30979900
Accessories & Spares	Order No.
Spares Kit Con C&O EH/QMB26/4200	A30751815
Spares Kit Module EH/QMB26/4200	A30751820
Spares Kit Shim EH/QMB12/26/4200	A30751825
Inlet Mesh Assembly EH2600	A60041571

Mechanical Booster Pump Accessories

OLM500 Oil Level Monitor

Fit the OLM500 in place of the oil sight-glass on the EH250 and EH500 oil seal reservoirs, and on the EH1200, EH2600 and EH4200 oil seal reservoirs and gear boxes. The OLM500 provides a switched output for remote activation or warning devices. Technical data: 24 V a.c. or d.c., maximum current 0.5 A.

Ordering Information

Product Description	Order No.
OLM500 oil level monitor*	A50434000
* Not suitable for ATEX boosters	

Inlet Seal with Mesh Screen

Designed to prevent objects falling into the inlet of our booster pumps, the mesh aperture is 3.3 mm.

Ordering Information

Product Description	Order No.
Inlet seal with mesh screen	
ISO63	C10521085
ISO100	C10523085
ISO160	C10524085

Stokes 6" Series Mechanical Booster Pumps



Edwards Stokes Vacuum 6" Mechanical Booster Pumps



The 1 11/16 inch extra large shaft diameter engineered into the Stokes 6" series provides the capability for use with higher powered motors, in addition to ensuring a uniquely rugged and durable mechanical booster. The use of higher powered motors in conjunction with the high differential specification, allows the pumps to operate at their full displacement from atmospheric pressure, with appropriately sized backing pumps the 612MB offers these advantages in a standard package.

The Stokes 6" series is also available in a process isolation series (five mechanical seals) for optimum protection from dust and particulate contamination in arduous duty applications.

All mechanical vacuum boosters must be backed by a primary vacuum pump designed to discharge to atmospheric pressure. Below is a list of commonly used backing pumps:

- Oil Sealed Pumps (EM or EV)
- Liquid Ring Pump (Two-stage LR Series)
- Piston Pumps (Stokes Microvac Series)
- Dry Pump (GV Drystar or Chemical Drystar)

Features & Benefits

- Mechanical shaft seal - improved life and serviceability
- Ringfeder® keyless gear locking system - stronger, faster timing
- Large shaft diameters - allowing improved performance at high pressures
- Belt drive or direct drive capability - flexibility of operating speeds and motor power
- Vertical or horizontal gas flow - flexibility of orientation
- Drive end roller bearing - resists belt pull and thermal effects
- Over-sized anti-friction bearings - increased uptime and longer service intervals
- Rugged proven design and construction
- Air Cooled - utility savings
- Unique impeller design -Dynamically balanced to minimise vibration
- High volumetric efficiency - optimal performance
- High differential pressure - operation capability
- Available by-pass option for improved pumpdown
- Available process isolation seal option-optimum protection from dust and particulate contamination

Applications

Typical applications for the Stokes 6" series mechanical booster pumps includes:

- Automotive
- Chemical processing
- Heat treatment
- Leak detection
- Metallurgy
- PET processing
- Pharmaceuticals
- Thermal processing
- Transformer drying and cable fluid conditioning
- Vacuum coating
- Vacuum melting
- Many other industrial applications

Stokes 6" series mechanical boosters are available in sizes 1020-6630 m³h⁻¹ / 612-3900 ft³min⁻¹. Features include:

- Rugged design for reliable and extended operation
- Simple maintenance features incorporated in design
- Vertical or horizontal gas flow
- Options of direct drive motors or bare shaft machines
- Options of by pass technology to reduce pump down time and process isolation seals
- Dynamically balanced impellers

Overview

Used in conjunction with rotary-piston, rotary vane, dry vacuum and liquid ring pumps, Stokes 6" series will increase pumping speed at working pressures and shorten pump down time significantly. Whether your objective is to reduce valuable time from the front end of your pumping cycle, or to substantially boost pumping capacity for high out-gassing applications, the result is the same - significantly reduced cycle times.

Stokes 6" series are compatible with any make or type of vacuum pumping system. The boosters can be mounted separately, or on the inlet of the backing pump. The latter forms a compact integrated package as a mechanical booster system. For even lower-pressure applications, two Stokes 6" series can be used in series with one backing pump. This results in a significantly lower-cost and space-saving pumping system.

Bypass technology is available in the 615 model to enhance your productivity further, while also assuring consistent, reproducible vacuum processing. The bypass valve limits the maximum differential pressure, enabling the booster to start from atmosphere and provide increased pumping capacity over the full pressure range. Eliminating the electrical pressure switch insures continuous, booster operation regardless of vacuum level.

Stokes 607 Series Mechanical Booster Pumps

Stokes 6" series mechanical boosters are designed to be used in conjunction with rotary-piston, dry vacuum, rotary vane and liquid ring pumps to increase pumping speed at working pressures and shorten pump down time significantly. The Stokes 6" series can be mounted separately or on the inlet of the backing pump to create a compact integrated package.

Featuring an extra large diameter shaft, the Stokes 6" series has the capability for use with higher powered motors in addition to ensuring a uniquely rugged and durable mechanical booster. This allows the pumps to operate at their full displacement from atmospheric pressure with an appropriately sized backing pump.



Features & Benefits

- Mechanical shaft seal – improved life and serviceability
- Ringfeder® keyless gear locking system – stronger, faster timing
- Large shaft diameters – allowing improved performance at high pressures
- Belt drive or direct drive capability
- Vertical or horizontal gas flow

Technical Data

Displacement	
V belt 2750 rpm	1589m ³ h ⁻¹ / 935ft ³ min ⁻¹
Direct drive 1800 rpm	1040m ³ h ⁻¹ / 612ft ³ min ⁻¹
Direct drive 3000 rpm	1733m ³ h ⁻¹ / 1020ft ³ min ⁻¹
Direct drive 3600 rpm	2080m ³ h ⁻¹ / 1224ft ³ min ⁻¹
Inlet/outlet flanges	6" ASA/ANSI
Motor power	5 / 20hp (7.5kW)
Cooling method	Air Cooled
Oil capacity (horizontal flow)	1.9 litre / 0.51gal
Oil capacity (vertical flow)	4.1 litre / 1.1gal
Max pressure differential	506mbar / 380Torr
Max temp rise	135°C / 275°F
Max discharge temp	191°C / 375°F
Weight bare shaft	215kg / 475lbs
Weight TEFC direct drive	408kg / 900lbs
Recommended Oil	V- Lube H

Dimensions

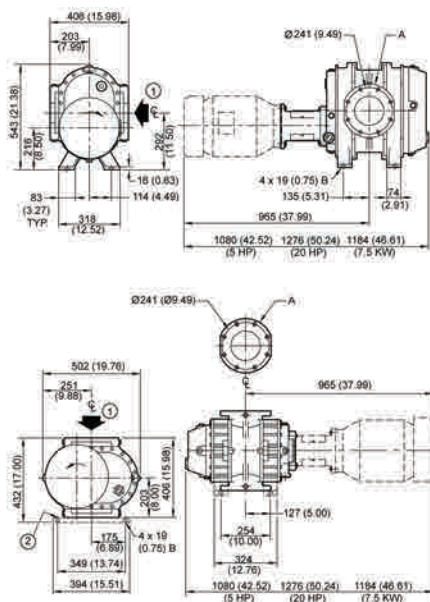

A 6" pipe flange connection 11" (279 mm) OD x (152 mm) ID 8 x 3/4-10 NC-2B x 1 1/8" (29 mm) holes straddle both CL both flanges
B DIA. Holes

1. STD Inlet 2. Optional feet

Ordering Information

Product Description	Order No.
607 MHR CE, 7.5kW, 230/400V, 3-ph, 50Hz @3000rpm	900607MHR601
607 MHR CE, 7.5kW, 200-220V/380V, 3-ph, 50/60Hz @3000/3600rpm	900607MHR602
607 MVR CE, 7.5kW, 230/400V, 3-ph, 50Hz @ 3000rpm	900607MVR601
607 MVR CE, 7.5kW, 200-220V/380V, 3-ph, 50/60Hz @ 3000/3600rpm	900607MVR602
607 MHR (Bare shaft) Horizontal flow	900607MHR
607 MVR (Bare shaft) Vertical flow	900607MVR
607 MH20, 20 hp, 230/460V, 3-ph, 60Hz @ 1800rpm	900-607-MH20
607 MV05, 5 hp, 230/460V, 3-ph, 60Hz @ 1800rpm	900607MV05
607 MV20, 20 hp, 230/460V, 3-ph, 60Hz @ 1800rpm	900607MV20
607 MH05, 5 hp, 230/460V, 3-ph, 60Hz @ 1800rpm	900607MH05
Accessories & Spares	Order No.
Replacement 6" booster Mseal - seal kit	607552001
Replacement 6" booster - maintenance kit	607552002

Stokes 607 Series Process Isolation Boosters



Stokes 6" series mechanical boosters are designed to be used in conjunction with rotary-piston, dry vacuum, rotary vane and liquid ring pumps to increase pumping speed at working pressures and shorten pump down time significantly. They incorporate five mechanical seals for optimum protection from dust and particulate contamination and can be mounted separately or on the inlet of the backing pump to create a compact integrated package.

Featuring an extra large diameter shaft, the Stokes 6" series has the capability for use with higher powered motors in addition to ensuring a uniquely rugged and durable mechanical booster.

Features & Benefits

- Mechanical shaft seal – improved life and serviceability
- Ringfeder® keyless gear locking system – stronger, faster timing
- Large shaft diameters – allowing improved performance at high pressures
- Belt drive or direct drive capability
- Vertical or horizontal gas flow

Technical Data

Displacement	
V belt (2750 rpm)	1589m ³ h ⁻¹ / 935ft ³ min ⁻¹
Direct drive (3000 rpm)	1733m ³ h ⁻¹ / 1020ft ³ min ⁻¹
Direct drive (3600 rpm)	2080m ³ h ⁻¹ / 1224ft ³ min ⁻¹
Inlet/outlet flanges	6" ASA/ANSI flange
Motor power EU/Asia	7.5kW
Motor power US TEFC	10hp
Cooling water	7.6-11.4l min ⁻¹ / 2-3gal min ⁻¹
Oil capacity (horizontal flow)	1.9 litre / 0.51gal
Oil capacity (vertical flow)	4. litre / 1.1gal
Max pressure differential	506 mbar / 380 Torr
Max temp rise	135°C / 275°F
Max discharge temp	191°C / 375°F
Weight bare shaft	215kg / 475lbs
Weight TEFC direct drive	345kg / 760lbs
Recommended Oil	V- Lube H

Dimensions

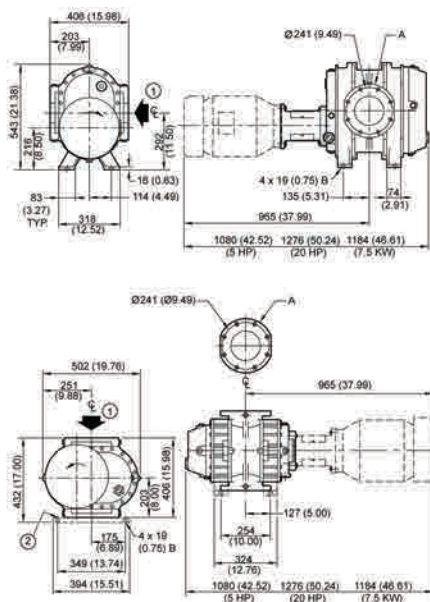

A 6" pipe flange connection 11" (279 mm) OD x (152 mm) ID 8 x 3/4-10 NC-2B x 1 1/8" (29 mm) holes straddle both CL both flanges
B DIA. Holes

1. STD Inlet 2. Optional feet

Ordering Information

Product Description	Order No.
607 5HR CE 7.5kW, 230/400V, 3-ph, 50Hz @ 3000rpm	9006075HR601
607 5HR CE 7.5kW, 200-220/380V, 3-ph, 50/60Hz @ 3000/3600rpm	9006075HR602
607 5H10, 10hp, 230/460V, 3-ph, 60Hz @ 1800rpm	9006075H10
607 5HR (Bare shaft) Horizontal flow	9006075HR
607 5V10, 10hp, 230/460V, 3-ph, 60Hz @ 1800rpm	9006075V10
607 5VR (Bare shaft) Vertical flow	9006075VR
607 5VR CE 7.5kW, 230/400V, 3-ph, 50Hz @ 3000rpm	9006075VR601
607 5VR CE 7.5kW, 200-220/380V, 3-ph, 50/60Hz @ 3000/3600rpm	9006075VR602
Accessories & Spares	Order No.
Replacement 6" booster Mseal - seal kit	607552001
Replacement 6" booster - maintenance kit	607552002
Process isolation seal kit	607552004

Stokes 615 Series Mechanical Booster Pumps

Stokes 6" series mechanical boosters are designed to be used in conjunction with rotary-piston, dry vacuum, rotary vane and liquid ring pumps to increase pumping speed at working pressures and shorten pump down time significantly. The Stokes 6" series can be mounted separately or on the inlet of the backing pump to create a compact integrated package.

Featuring an extra large diameter shaft, the Stokes 6" series has the capability for use with higher powered motors in addition to ensuring a uniquely rugged and durable mechanical booster. This allows the pumps to operate at their full displacement from atmospheric pressure with an appropriately sized backing pump.



Features & Benefits

- Mechanical shaft seal – improved life and serviceability
- Ringfeder® keyless gear locking system – stronger, faster timing
- Large shaft diameters – allowing improved performance at high pressures
- Belt drive or direct drive capability
- Vertical or horizontal gas flow

Technical Data

Displacement	
V belt (2750 rpm)	3375m ³ h ⁻¹ / 2000ft ³ min ⁻¹
Direct drive (1800 rpm)	2210m ³ h ⁻¹ / 1300ft ³ min ⁻¹
Direct drive (3000 rpm)	3685m ³ h ⁻¹ / 2170ft ³ min ⁻¹
Direct drive (3600 rpm)	4420m ³ h ⁻¹ / 2600ft ³ min ⁻¹
Inlet/outlet flanges	8" ASA/ANSI flange
Motor power EU/Asia	11kW
Motor power US TEFC	10hp
Cooling method	Air cooled
Oil capacity (horizontal flow)	1.9 litre / 0.51gal
Oil capacity (vertical flow)	4.1 litre / 1.1gal
Max pressure differential	506mbar / 380Torr
Max temp rise	135°C / 275°F
Max discharge temp	191°C / 375°F
Weight bare shaft	234kg / 515 lbs
Weight TEFC direct drive	390kg / 860lbs
Recommended Oil	V- Lube H

Dimensions

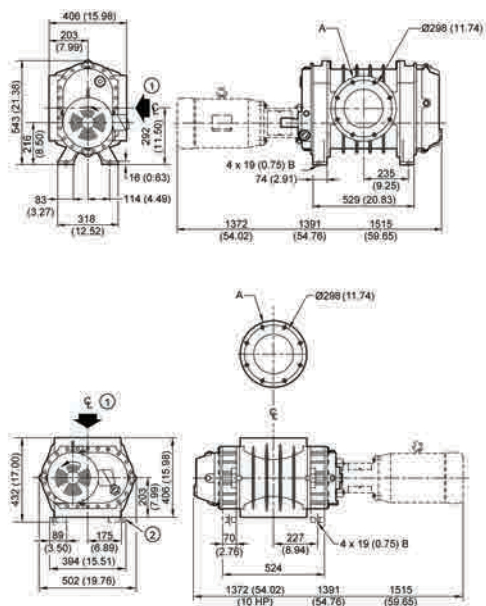

A 6" pipe flange connection 11" (279 mm) OD x (152 mm) ID 8 x 3/4-10 NC-2B x 1 1/8" (29 mm) holes straddle both CL both flanges
B DIA. Holes

1. STD Inlet 2. Optional feet

Ordering Information

Product Description	Order No.
615 MHR CE 11kW, 400V, 3-ph, 50Hz @ 3000rpm	900615MHR601
615 MHR CE 11kW, 200-220/380V, 3-ph, 50/60Hz @ 3000/3600rpm	900615MHR602
615 MV10, 10hp, 230/460V, 3-ph, 60Hz @ 1800rpm	900615MV10
615 MV15, 15hp, 230/460V, 3-ph, 60Hz @ 3600rpm	900615MV15
615 MVR (Bare shaft) Vertical flow	900615MVR
615 MVR CE 11kW, 400V, 3-ph, 50Hz @ 3000rpm	900615MVR601
615 MVR CE 11kW, 200-220/380V, 3-ph, 50/60Hz @ 3000/3600rpm	900615MVR602
615 MH10, 10hp, 230/460V, 3-ph, 60Hz @ 1800rpm	900615MH10
615 MH15, 15hp, 230/460V, 3-ph, 60Hz @ 3600rpm	900615MH15
615 MHR (Bare shaft) Horizontal flow	900615MHR
Accessories & Spares	Order No.
Replacement 6" booster Mseal - seal kit	607552001
Replacement 6" booster - maintenance kit	607552002

Stokes 615 Series Process Isolation Boosters



Stokes 6" series process isolation boosters are designed to be used in conjunction with rotary-piston, dry vacuum, rotary vane and liquid ring pumps to increase pumping speed at working pressures and shorten pump down time significantly. They incorporate five mechanical seals for optimum protection from dust and particulate contamination, and can be mounted separately or on the inlet of the backing pump to create a compact integrated package.

Featuring an extra large diameter shaft, the Stokes 6" series has the capability for use with higher powered motors in addition to ensuring a uniquely rugged and durable mechanical booster. This allows the pumps to operate at their full displacement from atmospheric pressure with an appropriately sized backing pump.

Features & Benefits

- Mechanical shaft seal – improved life and serviceability
- Ringfeder® keyless gear locking system – stronger, faster timing
- Large shaft diameters – allowing improved performance at high pressures
- Belt drive or direct drive capability
- Vertical or horizontal gas flow

Technical Data

Displacement	
V belt (2750 rpm)	3375m ³ h ⁻¹ / 2000ft ³ min ⁻¹
Direct drive (3000 rpm)	3685m ³ h ⁻¹ / 2170ft ³ min ⁻¹
Direct drive (3600 rpm)	4420m ³ h ⁻¹ / 2600ft ³ min ⁻¹
Inlet/outlet flanges	8" ASA/ANSI flange
Motor power EU/Asia	11kW
Motor power US TEFC	15hp
Cooling water	7.6-11.4 l min ⁻¹ / 2-3 gal min ⁻¹
Oil capacity (horizontal flow)	1.9 litre / 0.51gal
Oil capacity (vertical flow)	4.1 litre / 1.1gal
Max pressure differential	506mbar / 380Torr
Max temp rise	135°C / 275°F
Max discharge temp	191°C / 375°F
Weight bare shaft	234kg / 515lbs
Weight TEFC direct drive	397kg / 875lbs
Recommended Oil	V- Lube H

Dimensions

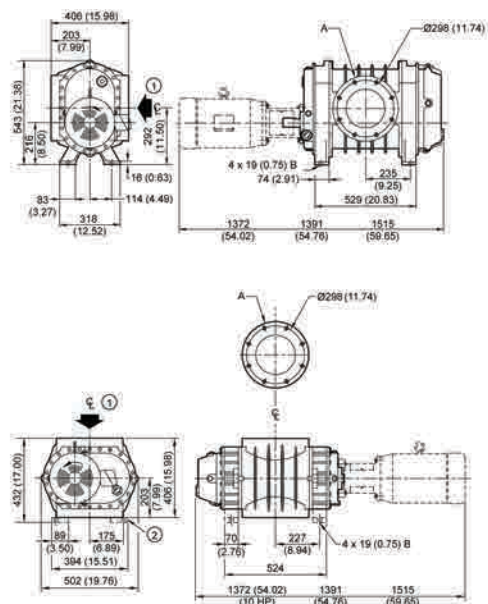

A 8" pipe flange connection 13 1/2" (343 mm) OD x 8" (203 mm) ID 8 x 3/4-10 NC-2B x 1 1/8" (29 mm) holes straddle both CL both flanges
B DIA. Holes

1. STD Inlet 2. Optional feet

Ordering Information

Product Description	Order No.
615 5HR CE 11kW, 230/400V, 3-ph, 50Hz @ 3000rpm	9006155HR601
615 5HR CE 11kW, 200-220/380V, 3-ph, 50/60Hz @ 3000/3600rpm	9006155HR602
615 5H15, 15hp, 230/460V, 3-ph, 60Hz @ 3600rpm	9006155H15
615 5HR (Bare shaft) Horizontal flow	9006155HR
615 5V15, 15hp, 230/460V, 3-ph, 60Hz @ 3600rpm	9006155V15
615 5VR (Bare Shaft) Vertical flow	9006155VR
615 5VR CE 11kW, 230/400V, 3-ph, 50Hz @ 3000rpm	9006155VR601
615 5VR CE 11kW, 200-220/380V, 3-ph, 50/60Hz @ 3000/3600rpm	9006155VR602
Accessories & Spares	Order No.
Replacement 6" booster Mseal - seal kit	607552001
Replacement 6" booster - maintenance kit	607552002
Process isolation seal kit	607552004

Stokes 61B Series By-Pass Mechanical Booster Pumps

Stokes 61B by-pass mechanical boosters are designed to be used in conjunction with rotary-piston, dry vacuum, rotary vane and liquid ring pumps to increase pumping speed at working pressures and shorten pump down time significantly. The Stokes 61B by-pass boosters include an integral by-pass valve enabling the booster to start from atmosphere, eliminating the need for a vacuum pressure switch and ensures continuous operation regardless of vacuum level. The Stokes 61B can be mounted separately or on the inlet of the backing pump to create a compact integrated package.



Features & Benefits

- Mechanical shaft seal – improved life and serviceability
- Ringfeder® keyless gear locking system – stronger, faster timing
- Large shaft diameters – allowing improved performance at high pressures
- Belt drive or direct drive capability
- Vertical or horizontal gas flow

Technical Data

Displacement	
V belt (2750 rpm)	3375m ³ h ⁻¹ / 2000ft ³ min ⁻¹
Direct drive (1800 rpm)	2210m ³ h ⁻¹ / 1300ft ³ min ⁻¹
Direct drive (3000 rpm)	3685m ³ h ⁻¹ / 2170ft ³ min ⁻¹
Direct drive (3600 rpm)	4420m ³ h ⁻¹ / 2600ft ³ min ⁻¹
Inlet/outlet flanges	8" ASA/ANSI flange
Motor power EU/Asia	18.5kW
Motor power US TEFC	10/25hp
By-pass available	Yes
Cooling method	Air cooled
Oil capacity (horizontal flow)	1.9 litre / 0.51gal
Oil capacity (vertical flow)	4.1 litre / 1.1gal
Max temp rise	135°C / 275°F
Max discharge temp	191°C / 375°F
Weight bare shaft	284kg / 625lbs
Weight TEFC direct drive	530kg / 1170lbs

Dimensions

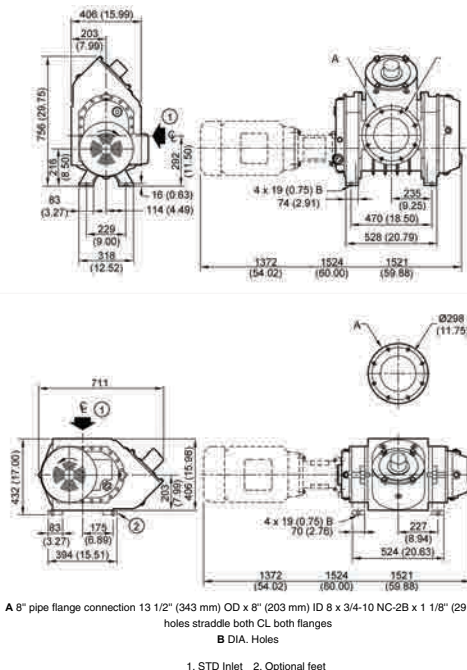

Ordering Information

Product Description	Order No.
61B MHR CE, 18.5kW, 400V, 3-ph, 50Hz @ 3000rpm	90061BMHR601
61B MHR CE, 18.5kW, 200-220/380V, 3-ph, 50/60Hz @ 3000/3600rpm	90061BMHR602
61B MH10, 10hp, 230/460V, 3-ph, 60Hz @ 1800rpm	90061BMH10
61B MH25, 25hp, 230/460V, 3-ph, 60Hz @ 3600rpm	90061BMH25
61B MHR (Bare shaft) Horizontal flow	90061BMHR
61B MV10, 10hp, 230/460V, 3-ph, 60Hz @ 1800rpm	90061BMV10
61B MV25, 25hp, 230/460V, 3-ph, 60Hz @ 3600rpm	90061BMV25
61B MVR (bare shaft) Vertical flow	90061BMVR
61B MVR CE, 18.5kW, 400V, 3-ph, 50Hz @ 3000rpm	90061BMVR601
61B MVR CE, 18.5kW, 200-220/380V, 3-ph, 50/60Hz @ 3000/3600rpm	90061BMVR602
Accessories & Spares	Order No.
Replacement 6" booster Mseal - seal kit	607552001
Replacement 6" booster - maintenance kit	607552002

Stokes 61B Series Process Isolation Boosters



Stokes 61B series process isolation boosters are designed to be used in conjunction with rotary-piston, dry vacuum, rotary vane and liquid ring pumps to increase pumping speed at working pressures and shorten pump down time significantly. It incorporates five mechanical seals for optimum protection from dust and particulate contamination. It also includes an integral by-pass valve enabling the booster to start from atmosphere, eliminating the need for a vacuum pressure switch to ensure continuous operation regardless of vacuum level. The Stokes 61B series can be mounted separately or on the inlet of the backing pump to create a compact integrated package.

Features & Benefits

- Mechanical shaft seal – improved life and serviceability
- Ringfeder® keyless gear locking system – stronger, faster timing
- Large shaft diameters – allowing improved performance at high pressures
- Belt drive or direct drive capability
- Vertical or horizontal gas flow

Technical Data

Displacement	
V belt (2750 rpm)	3375m ³ h ⁻¹ / 2000ft ³ min ⁻¹
Direct drive (3000 rpm)	3685m ³ h ⁻¹ / 2170ft ³ min ⁻¹
Direct drive (3600 rpm)	4420m ³ h ⁻¹ / 2600ft ³ min ⁻¹
Inlet/outlet flanges	8" ASA/ANSI flange
Motor power EU/Asia	18.5kW
Motor power US TEFC	25 hp
By-pass available	Yes
Cooling water	7.6 - 11.4l min ⁻¹ / 2 - 3gal min ⁻¹
Oil capacity (horizontal flow)	1.9 litre / 4.1gal
Oil capacity (vertical flow)	4.1 litre / 8.8gal
Max temp rise	135°C / 275°F
Max discharge temp	191°C / 375°F
Weight bare shaft	284kg / 625lbs
Weight TEFC direct drive	538kg / 1185lbs
Recommended Oil	V- Lube H

Dimensions

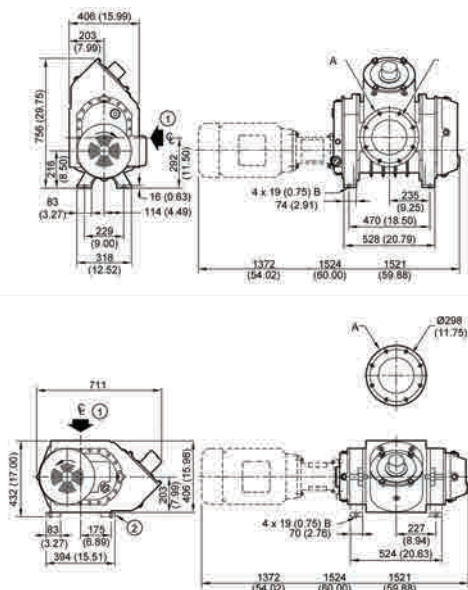

A 88° pipe flange connection 13 1/2" (343 mm) OD x 8" (203 mm) ID 8 x 3/4-10 NC-2B x 1 1/8" (29 mm) holes straddle both CL both flanges
B DIA. Holes

1. STD Inlet 2. Optional feet

Ordering Information

Product Description	Order No.
61B 5HR CE 18.5kW, 230/400V, 3-ph, 50Hz @ 3000rpm	90061B5HR601
61B 5HR CE 18.5kW, 200-220/380V, 3-ph, 50/60Hz @ 3000/3600rpm	90061B5HR602
61B 5H25, 25hp, 230/460V, 3-ph, 60Hz @ 3600rpm	90061B5H25
61B 5HR (Bare Shaft) Horizontal flow	90061B5HR
61B 5V25, 25hp, 230/460V, 3-ph, 60Hz @ 3600rpm	90061B5V25
61B 5VR (Bare shaft) Vertical flow	90061B5VR
61B 5VR CE 18.5kW, 230/400V, 3-ph, 50Hz @ 3000rpm	90061B5VR601
61B 5VR CE 18.5kW, 200-220/380V, 3-ph, 50/60Hz @ 3000/3600rpm	90061B5VR602
Accessories & Spares	Order No.
Replacement 6" booster Mseal - seal kit	607552001
Replacement 6" booster - maintenance kit	607552002
Process isolation seal kit	607552004

Stokes 622 Series Mechanical Booster Pumps

Stokes 6" series mechanical boosters are designed to be used in conjunction with rotary-piston, dry vacuum, rotary vane and liquid ring pumps to increase pumping speed at working pressures and shorten pump down time significantly. The Stokes 6" series can be mounted separately or on the inlet of the backing pump to create a compact integrated package.

Featuring an extra large diameter shaft, the Stokes 6" series has the capability for use with higher powered motors in addition to ensuring a uniquely rugged and durable mechanical booster. This allows the pumps to operate at their full displacement from atmospheric pressure with an appropriately sized backing pump.



Features & Benefits

- Mechanical shaft seal – improved life and serviceability
- Ringfeder® keyless gear locking system – stronger, faster timing
- Large shaft diameters – allowing improved performance at high pressures
- Belt drive or direct drive capability
- Vertical or horizontal gas flow

Technical Data

Displacement	
V belt (2750 rpm)	5100m ³ h ⁻¹ / 3000ft ³ min ⁻¹
Direct drive (3000 rpm)	5525m ³ h ⁻¹ / 2350ft ³ min ⁻¹
Direct drive (3600 rpm)	6630m ³ h ⁻¹ / 3900ft ³ min ⁻¹
Inlet/outlet flanges	8" ASA/ANSI flange
Motor power EU/Asia	18.5kW
Motor power US TEFC	25hp
Cooling method	Air cooled
Oil capacity (horizontal flow)	1.9 litre / 0.51gal
Oil capacity (vertical flow)	4.1 litre / 1.1gal
Max pressure differential	333mbar / 250Torr
Max temp rise	151°C / 275°F
Max discharge temp	177°C / 350°F
Weight bare shaft	335kg / 740lbs
Weight TEFC direct drive	617kg / 1360lbs
Recommended Oil	V- Lube H

Dimensions

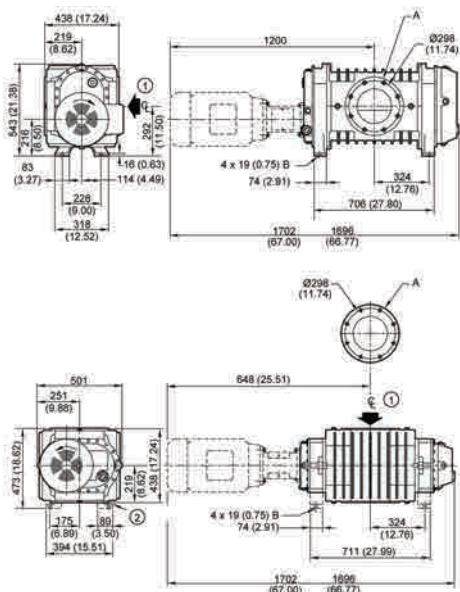

A 8" pipe flange connection 13 1/2" (343 mm) OD x 8" (203 mm) ID 8 x 3/4-10 NC-2B x 1 1/8" holes straddle both CL both flanges
B DIA. Holes

1. STD Inlet 2. Optional feet

Ordering Information

Product Description	Order No.
622 MHR CE 18.5kW, 400V, 3-ph, 50Hz @ 3000rpm	900622MHR601
622 MHR CE 18.5kW, 200-220/380V, 3-ph, 50/60Hz @ 3000/3600rpm	900622MHR602
622 MH25, 25hp, 230/460V, 3-ph, 60Hz @ 3600rpm	900622MH25
622 MHR (Bare shaft) Horizontal flow	900622MHR
622 MV25, 25hp, 230/460V, 3-ph, 60Hz @ 3600rpm	900622MV25
622 MVR (Bare shaft) Vertical flow	900622MVR
622 MVR CE 18.5kW, 400V, 3-ph, 50Hz @ 3000rpm	900622MVR601
622 MVR CE 18.5kW, 200-220/380V, 3-ph, 50/60Hz @ 3000/3600rpm	900622MVR602
Accessories & Spares	Order No.
Replacement 6" booster Mseal - seal kit	607552001
Replacement 6" booster - maintenance kit	607552002

HV8000 Mechanical booster pump

The Edwards HV8000 high vacuum mechanical booster has been developed to provide high reliability operation in aggressive environments. With a nominal pumping speed of $7200 \text{ m}^3\text{h}^{-1}$ ($4241 \text{ ft}^3\text{min}^{-1}$) at 50Hz, it is ideal for large industrial and chemical applications including, steel degassing, metallurgy, coating, electron beam welding and the process engineering industries.



Features & Benefits

- Derived from the successful range of HV pressure blowers, the HV8000 is designed for arduous duty cycles and high power applications.
- Ideal for larger scale, harsh industrial and chemical applications, the HV8000 is available in Industrial, ATEX or Explosion Proof configurations.
- The HV8000 may be ordered as either bare shaft or with motor fitted. Variable frequency drives may be specified for greater versatility.
- The HV8000 is available in vertical or horizontal gas flow configuration.
- For long service life, the external shaft seal is water-cooled.

Dimensions

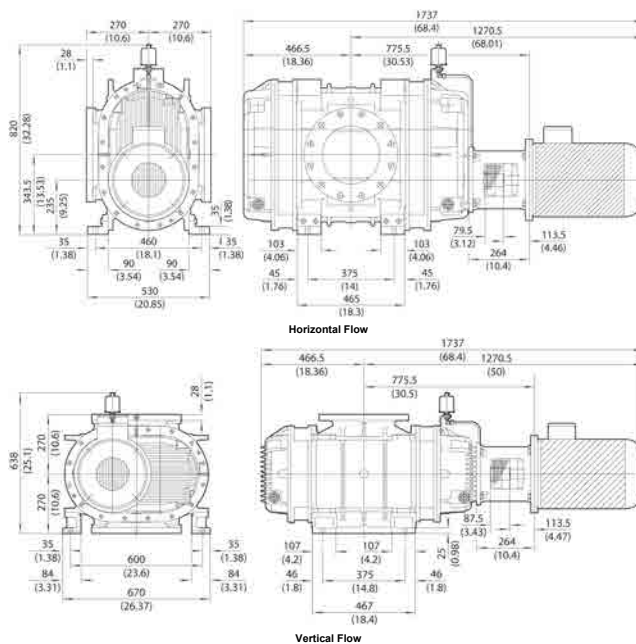

Technical Data

Displacement (swept volume)	
50Hz	7200 m ³ h ⁻¹ / 4241 ft ³ min ⁻¹
60Hz	8640 m ³ h ⁻¹ / 5089 ft ³ min ⁻¹
Max rotation speed	
50Hz	3000 rpm
60Hz	3600 rpm
Max pressure differential	
50Hz	190 mbar / 143 Torr
60Hz	120 mbar / 90 Torr
Ultimate (depends on backing set)	
50Hz	1.5 x 10 ⁻⁴ mbar / 1 x 10 ⁻⁴ Torr
60Hz	2 x 10 ⁻⁴ mbar / 1.5 x 10 ⁻⁴ Torr
Electrical supply voltage	
50Hz	380-415V, 3-ph
60Hz	440-460V, 3-ph
Standard motor power	
50Hz	15 kW / 20 hp
60Hz	18.5 kW / 25 hp
Standard backing set speed requirements	2600 m ³ h ⁻¹ / 1530 ft ³ min ⁻¹
Recommended oil	Mobile SHC 629
Max oil capacity (vertical gas flow config)	8.3 litre / 2.18 US gal
Inlet/outlet connection	10" class 150 ASME B16.5
Inlet/outlet cooling water connection	Rp 1/2 ISO 7-1 (1/2 BSP)
End cover purge gas inlet	Rp 3/8 ISO 7-1 (3/8 BSP)
Max cooling water supply pressure	4 bar / 58 psi
Max cooling water supply temp	35°C / 95°F
Cooling water flow rate	15 l min ⁻¹ / 3.96 US gal min ⁻¹
Noise level	82 dB(A)
Weight (without motor)	580 kg / 1279 lb
Weight (with standard motor)	720 kg / 1587 lb

Ordering Information

Product Description	Order No.
HV8000IND VF 380-415V, 3-ph, 50Hz, 18.5kW	A31101935
HV8000IND VF 440-460V, 3-ph, 60Hz, 25hp	A31101936
HV8000IND VF bareshaft	A31101985
HV8000IND HF 380-415V, 3-ph, 50Hz, 18.5kW	A31102935
HV8000IND HF 440-460V, 3-ph, 60Hz, 25hp	A31102936
HV8000IND HF bareshaft	A31102985
Accessories & Spares	Order No.
HV8000 VF motor mounting kit IEC	A31101002
HV8000 VF motor mounting kit NEMA	A31101006
HV8000 HF motor mounting kit IEC	A31102002
HV8000 HF motor mounting kit NEMA	A31102006
Gear Box Oil 4 Ltr Mobil SHC 629	H11023011
HV8000 Set of O-Rings spare	A31101801
HV8000 Mech seal kit spare	A31101802
HV8000 mech seal + sleeve kit spare	A31101803
HV8000 gear set spare	A31101804
HV8000 bearings kit spare	A31101805
HV8000 rotors kit spare	A31101806
HV8000 oil reservoir spare	A31101807
HV8000 sight glass spare	A31101808

HV30000 Mechanical Booster Pump

The HV pump systems combine Edwards expertise in manufacture and assembly of complete industrial vacuum systems with Dresser's world-renowned Roots pump technology. These pumps are backed by Edwards Dry Pumps or Mechanical Booster pumps.

This range of high capacity mechanical booster pumps is designed to operate reliably for long periods with no need for maintenance. The HV pumps can be fitted with an inverter to allow them to be started at atmospheric pressure, at the same time as the dry pumps.



Features & Benefits

- Water cooled shaft seals and after cooler
- Fitted with thermal snap-switch, to protect the pump from over temperature
- Nitrogen purge inlet fitted as standard
- Vertical flow, direct drive (horizontal optional)
- Control with inverter, or interlock with a pressure switch input

Dimensions

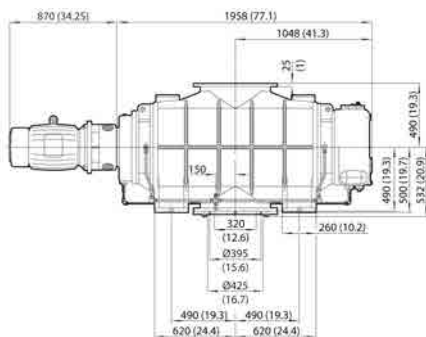

Applications

- Semiconductor processing
- Vacuum distillation
- Vacuum packaging
- Steel degassing
- Thin film coating

Performance Curves

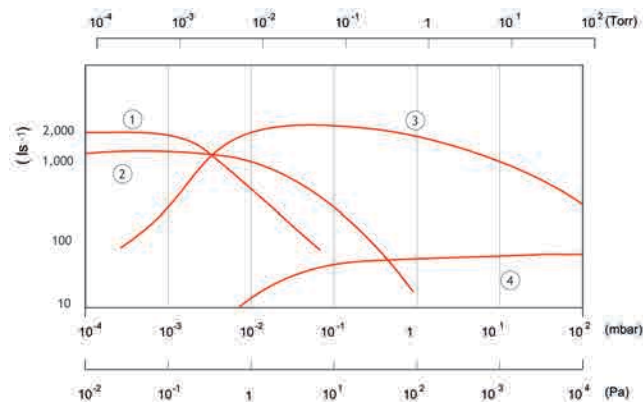

- (1) In their most efficient range, booster pumps
- (2) fill the gap between the pumping speeds of vapour diffusion pumps
- (3) vapour booster pumps
- (4) and rotary or dry high vacuum pumps

Technical Data

Displacement (Supply)	
50 Hz	30000 m ³ h ⁻¹ 17700 ft ³ min ⁻¹
60 Hz	36000 m ³ h ⁻¹ 21204 ft ³ min ⁻¹
Maximum pressure differential (Supply)	
50 Hz	29 mbar 22 Torr
60 Hz	24 mbar 18 Torr
Recommended backing pumps	2 x GV400 / DP400 and 2 x EH4200
Electrical supply	400 V 50 Hz 3-ph or 460 V 60 Hz 3-ph
Motor power	
50 Hz	30 kW / 40 hp
60 Hz	#
Cooling-water supply	
Maximum pressure	10 bar / 145 psi
Inlet temperature	20 °C
Recommended oil	Ultragrade 20
Oil capacity	33 l / 34.9 qt
Ambient operating temperature	5° - 40 °C
Maximum operating humidity	100% RH
Weight (without motor)	3100 kg / 6820 lb
# On request	

Ordering Information

Product Description	Order No.
HV30000 High Capacity Mechanical Booster Pump	HV30000 Mechanical Booster Pump
Accessories & Spares	Order No.
Ultragrade 20 Oil	H11024015
Ultragrade 20 Oil	H11024012
Ultragrade 20 Oil	H11024013
Ultragrade 20 Oil	H11024011
Ultragrade 20 Oil	H11024010

Chemical Dry Pumps



CXS Chemical dry pumps	381
CDX Dry pumps	385
EDP Series Chemical Dry Pumps	387

Chemical Dry Pumps

Introduction

Edwards is a market leader in dry pump technology and pioneer of dry vacuum for the chemical process, pharmaceutical and fine chemical industries. The CDX uses the very latest in screw pumping technology, whilst the EDP range utilizes the reverse claw mechanism, proven over more than 20 years and in over 100,000 installations worldwide, to provide a clean and robust vacuum solution.

Why Dry?

Dry running pumps have no oil, steam or water in the process volume. This eliminates, at source, the pollution traditionally associated with wet sealed vacuum systems and provides cost and materials handling benefits as the sealing medium does not have to be replenished:

- no contamination of the process stream
- no polluted effluent
- no messy oil drums
- improved processing with reduced down time
- lower utility and consumable costs

The proven and rugged non contacting designs, both screw and reverse claw mechanisms, include the ability to control pump body and internal gas temperatures allowing a comprehensive range of solvents, flammables and corrosives to be pumped. Systemized variants address the EU's explosive atmospheres (ATEX) directive for Category (Zone 0) T4 operation. The mechanisms are both highly tolerant to liquids and particles in the gas stream and are suitable for many applications, including:

- Distillation
- Drying
- Evaporation and crystallisation
- Filter/dryers
- Solvent recovery
- Reactor service
- House/central vacuum

The product range is available from $83 \text{ m}^3\text{h}^{-1} / 49 \text{ ft}^3\text{min}^{-1}$ to $900 \text{ m}^3\text{h}^{-1} / 530 \text{ ft}^3\text{min}^{-1}$ with capacity expandable to $30000 \text{ m}^3\text{h}^{-1} / 17660 \text{ ft}^3\text{min}^{-1}$ and an ultimate pressure of better than 10^{-2} mbar / 0.015 Torr using combinations of mechanical vacuum boosters. Applications Engineering is a core competence and Edwards are able to offer a comprehensive solutions package that includes:

- Process design
- Equipment specification and selection
- Safety and operating procedures
- Vacuum system and control integration
- Commissioning advice

Edwards have a full range of dry pumps with a set of characteristics suited to most applications.

CXS Dry Pumps



Edwards, a pioneer in dry pumping technology, launches a new generation of dry pumps for industrial applications.

Edwards has over 90 years of experience in harsh process vacuum applications, including dust and process contaminants handling, with more than 150,000 dry pumps installed worldwide.

The CXS Chemical Dry Screw Pump incorporates innovative, patented design features that establish a new standard in dry pumping.

Simple to Install and Use

Integral controller and safety systems for 'Plug and Pump', flexible operation.

High Reliability

Cutting edge screw technology for corrosion-free operation and robust liquid and solids handling.

Low Cost of Ownership

Best in class installation and running costs with up to 5 years between service.

Environmentally Friendly

Smooth, quiet running, <64 dB(A), no effluent generation and low utilities consumption.

Edwards Expertise

Global application engineering and service support.

EDP Series



A vertical claw pump with indirect cooling and temperature control - ideally suited to applications where there is the likelihood of liquid carry over, where cooling water is likely to be of low quality, or where close temperature control of the pump is required.

CDX Dry Pumps



The CDX 1000 and 1300 use the latest double ended screw technology to provide a peak speed of up to $1300 \text{ m}^3\text{h}^{-1} / 767 \text{ ft}^3\text{min}^{-1}$. Many features are patented and as with the GV range are able to handle large amounts of dust and water vapour with little or no effect on performance.

- Low cost of ownership in harsh conditions
- High reliability – dry mechanism proven in 100,000 installations
- Oil free mechanism – reduced maintenance
- Higher dust and water vapour tolerance
- Accessories to optimise pump performance to process variables
- Fast pump down with Edwards hydrokinetic drive booster pumps.

CXS Chemical Dry Screw Pump

Designed for High Reliability. Edwards patented screw-rotor design delivers excellent pumping speed and is part of an advanced thermal management system that maximizes pump performance and life of the seals, bearings, and motor to ensure long pump service life.

Adaptable to a Wide Range of Applications. CXS pumps are offered with a range of purge options, filters, catchpots, inlet isolation valves and silencers; together with our special high flow purge and solvent flush accessory enabling the inside of the pump to be kept clean without disassembly.

Long Service Intervals and Easy Swap-out. Long-life non-oxidizing gearbox oil enables service intervals of up to 5 years to be achieved. Quick-connect utility interfaces provide for rapid pump installation and exchange to improve factory up-time.

Low Cost of Ownership. Custom high-efficiency motor and drive system with advanced seal technology provides for greatly reduced power consumption. Minimal cooling water and purge gas requirements coupled with improved powertrain technology provide for long service intervals and near maintenance-free operation.

Minimum Workplace and Environmental Impact. CXS pumps are incredibly compact. Edwards advanced screw-rotor design provides for remarkably quiet, low vibration operation even without a silencer.

Simple to Install and Operate. CXS pumps are easily wheeled or fork-lifted into position, coupled to the process and services using the supplied mating connectors and run at the push of a button.

Ideal for Integration into Larger Systems. CXS pumps and combinations are supplied with serial (RS232) communication and LAN-based web-serving capability as standard. Optional modules are available to add Parallel (digital I/O) and Profibus control functionality.

At Your Service. Edwards has highly skilled applications specialists who will advise on the optimum configuration for your process or application.

CXS Innovative Technology

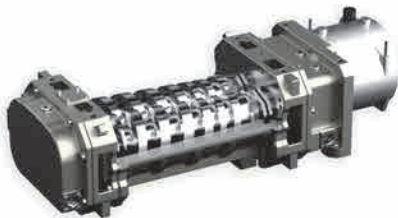

CXS Innovative Screw Technology

Advanced Screw Technology

- Edwards tapered screw technology results in smooth, gradual compression along the length of the rotor for improved thermal control and optimised pumping at all inlet pressures
- The cooling system and compression technology deliver outstanding performance and active temperature control protects the pump from thermal shocks, condensation and corrosion
- Advanced machining techniques and design features eliminate the need for rotor coatings while maintaining superb ultimate vacuum performance

Reliability

- Repeatable vacuum
- Excellent liquid handling (up to 25 litre slugs)
- Excellent solids handling (up to 1 kg slugs)
- No end-compression plate to trap solids and jam rotors or cause hydraulic locks
- Can flush with solvents, water or steam, online or offline
- Configurable pump parameters for system optimisation
- Special start-up and shutdown modes to free the rotors or avoid cold seizures, if required
- No interstage condensers to create the potential for corrosion

Control

- Integral PID pressure control with inbuilt inverter
- Flexible communications options
- No complex programming required
- Customisable for enhanced process optimisation
- Data monitoring via onboard communications options
- High torque motor 'jogging' to prevent seizure

Efficient Motor and Inverter Drive System

- Compact, high speed, water-cooled encapsulated motor
- 110 Hz operation for smaller footprint and lower noise
- High start torque for maximum restart capability
- Reduced bearings temperatures for longer life
- Matched inverter drive for increased efficiency
- Water-cooled inverter means lower temperature electronics, hence longer life

ATEX Certification

CAT 1/2 Systems

The CXS dry vacuum pump, certified as an ATEX Category 1 machine relying on constructional safety and containment, is safe to pump gases from gas group IIB3.

CAT 2 Systems

The standard protection concept for CXS ATEX Category 2 pump systems is 'Constructional Safety'. Solvent flush options if necessary can ensure constructional safety is maintained. CAT 2 containment options are also available.

Our experienced applications team are trained to provide expert advice on choosing the correct pumping system.

Applications Knowledge

Expert applications engineering is central to Edwards' success. We always provide solutions to customer problems. This can involve:

- Process design
- Equipment selection
- Integration into the plant control philosophy
- Safety considerations (e.g. HAZOPs)
- Advice at start-up, commissioning and training

CXS Combinations

Using an extensive range of pre-engineered modules Edwards CXS offers the capability to match most customer application needs.

Systemisation is made easy with CXS pumps. The following items are available as factory fitted standard matrix options or simple 'Bolt On' accessories:

- EH mechanical boosters*
- Condensers
- Receivers
- Knockout pots
- Dust filters
- Solvent flush kits
- Flame arrestors
- Isolation and control valves
- Exhaust silencer
- Instruments
- Inlet by-pass line for finer pressure control
- PC interfaces for control and data monitoring
- Ethernet, MCMµTim and Profibus interfaces
- Valves
- Base skirts
- Documentation packages

* Edwards EH series boosters feature our unique hydrokinetic drive which can have significant cost and performance advantages over direct drive machines. The hydrokinetic drive removes any need for pressure sensors or by-pass lines or inverters, and allows the booster to run from atmospheric pressure to ultimate vacuum, giving faster pumpdown and more flexible operation with less maintenance.

The requirement for these or other accessories is determined through expert applications engineering.

Standard CXS pumps and EH mechanical booster combinations

	EH500	EH1200	EH2600
CXS 160	●	●	
CXS 250		●	●

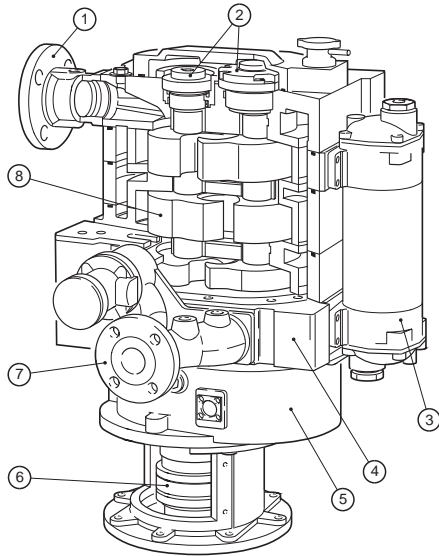

- | | |
|-------------------------------|------------------|
| 1 Inlet | 5 Gearbox |
| 2 Sealed high vacuum bearings | 6 Torque limiter |
| 3 Indirect cooling | 7 Outlet |
| 4 Rugged modular construction | 8 Reversed claw |

The Reverse Claw Mechanism

The EDP range are multistage claw mechanisms. Each stage comprises of two claw shaped rotors on parallel shafts, which rotate in opposite directions. The claws trap and compress the process gas, which takes a zig-zag path between the stages, as it is moved along the axis of the shaft from the inlet at the top to the exhaust at the bottom.

9

Page 380

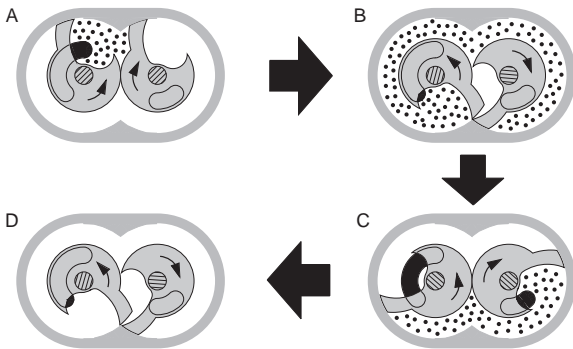

- | | |
|------------------|-------------------|
| A Inlet exposed | C Outlet isolated |
| B Inlet isolated | D Outlet exposed |

During each complete rotation of the claws, first the inlet port of each pair is exposed (to admit gas to the pump), then both the inlet and outlet are isolated (to trap and compress the gas) and finally the outlet is exposed (to expel the compressed gas).

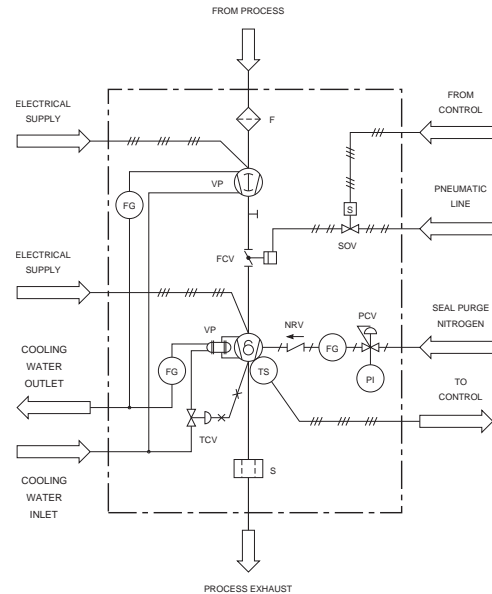

P&ID example: Typical dry pump system with mechanical booster and seal purge options

Accessory modules offered include:

Mechanical Boosters

Provide increased pumping speed & improved ultimate. Available with:

- Hydrokinetic drive for faster pumpdown
- Rotation sensors

Gas Purges

Used to dilute flammables and improve seal life

- Inlet purge*
- Shaft seal purge*

Safety

Edwards offer a comprehensive range of solutions to containment and constructional safety, to satisfy ATEX or your own requirements.

- Flame arrestors
- Solvent flush*
- Inlet isolation valves*

Vessels

Solvents and other liquids carried over in the process stream can be recovered upstream or downstream of the pump.

- Knock-out pot*
- Condenser*
- Receiver*

Acoustics

Silencers reduce pulsations in the exhaust and hence noise in the exhaust line. All silencers are drainable.

- Silencers

Monitoring & Control

Offerings range from gauges and simple 4-20 mA transmitters to fully enclosed bespoke control units.

- Temperature transmitters
- Pressure transmitters
- Pressure gauges
- Rotation sensors
- Inverter drives
- Control box

* Denotes item is available with solenoid/switch control/actuation.

All additional control and sensor requirements to achieve zoning are supplied with the flame arrestor module.

CXS160 chemical dry pump

Edwards pioneered the industrial dry vacuum pump in 1986 and now with more than 150,000 systems sold worldwide this Edwards expertise has been used to develop a dry pump capable of withstanding the harshest of process applications.

The CXS incorporates innovative screw design features with simplicity and reliability in mind, a 'Plug and Pump' philosophy has been adopted. As a result, the CXS has industry leading reliability, safety and low cost of ownership.



Features & Benefits

- Continuous vacuum from atmosphere to 10⁻³ mbar
- Integral temperature control
- Pumps corrosive vapours without deterioration
- Excellent liquid and solids handling
- Deeper vacuum than traditional technologies - not limited by seal fluid or cooling water temperature

Dimensions

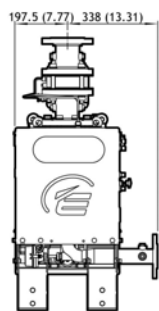

Front View

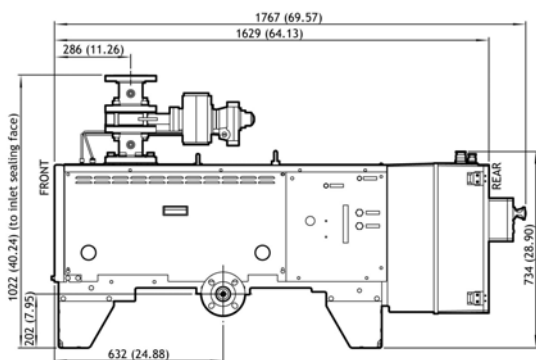

Left View

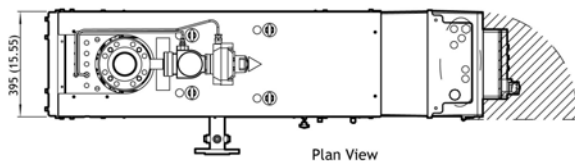

Plan View

Applications

- Drying
- Degassing
- Deodorisation
- Distillation
- Reactor service

Performance Curves

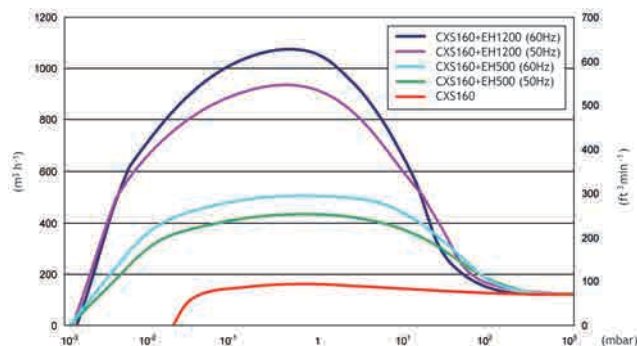

Technical Data

Maximum pumping speed	160 m ³ h ⁻¹ / 95 ft ³ min ⁻¹
Capacity at 10 mbar (7.5 Torr)	132 m ³ h ⁻¹ / 78 ft ³ min ⁻¹
Ultimate vacuum	<0.02 mbar / <0.015 Torr
Maximum back pressure - standard	1,200 mbar / 2.7 psig
Power consumption at 10 mbar (7.5 Torr)	3.6 kW / 4.8 hp
Standard motor	
(200 - 230V ±10%, 3 ph, 50/60 Hz)	7.5 kW
Standard motor	10 hp
(380 - 460V ±10%, 3 ph, 50/60 Hz)	
Cooling water flow rate, (adjustable)	4 - 10 lmin ⁻¹ / 1.1 - 2.6 galmin ⁻¹
Cooling water temperature 5 - 25 °C (41 - 77 °F) for T160 set-ups	5 - 35 °C / 41 - 95 °F
Max cooling water supply pressure	6.9 barg / 100 psig
Cooling water supply differential pressure	1.6 - 5.5 bar / 23 - 80 psi
Seal purge flow (max)	12 std slm / 0.424 std ft ³ min ⁻¹
Seal purge supply pressure, (min - max)	2.5 - 6.9 barg / 36 - 100 psig
Noise (max) with silencer	64 dB(A)
Weight (with frame and standard motor)	470 kg / 1,034 lbs
Process connection, inlet	3/DN80 ANSI/DIN
Process connection, outlet	2/DN50 ANSI/DIN

Ordering Information

Product Description	Order No.
CXS160 ATEX CAT 2&3 T3 Light duty	CS256000000
CXS160 ATEX CAT 2&3 T3 Light duty, Knitmesh inlet & exhaust flame arrestors	CS256020000
CXS160 ATEX CAT 2&3 T3 Light duty, Protego inlet & exhaust flame arrestors	CS256070000
CXS160 ATEX CAT 2&3 T3 Medium duty+	CS256100500
CXS160 ATEX CAT 2&3 T3 Medium duty+, Knitmesh inlet & exhaust flame arrestors	CS256120500
CXS160 ATEX CAT 2&3 T3 Medium duty+, Protego inlet & exhaust flame arrestors	CS256170500
CXS160 ATEX CAT 2&3 T160 Light duty	CS257000000
CXS160 ATEX CAT 2&3 T160 Light duty, Knitmesh inlet & exhaust flame arrestors	CS257020000
CXS160 ATEX CAT 2&3 T160 Light duty, Protego inlet & exhaust flame arrestors	CS257070000
CXS160 ATEX CAT 2&3 T160 Medium duty+	CS257100500
CXS160 ATEX CAT 2&3 T160 Medium duty+, Knitmesh inlet & exhaust flame arrestors	CS257120500
CXS160 ATEX CAT 2&3 T160 Medium duty+, Protego inlet & exhaust flame arrestors	CS257170500
CXS160 ATEX CAT 1 T3 Light duty, Knitmesh inlet & exhaust flame arrestors	CS256620000
CXS160 ATEX CAT 1 T3 Light duty, Protego inlet & exhaust flame arrestors	CS256670000
CXS160 ATEX CAT 1 T3 Medium duty+, Knitmesh inlet & exhaust flame arrestors	CS256720500
CXS160 ATEX CAT 1 T3 Medium duty+, Protego inlet & exhaust flame arrestors	CS256770500
Accessories & Spares	Order No.
Exhaust condensor	M52808500
Exhaust flame arrestor kit Elmac (Knitmesh)	M52809100
Exhaust flame arrestor kit Protego	M52809140
Exhaust Press Ind Kit (pressure gauge)	M52808480
Exhaust silencer	M52808550
Exhaust valve kit(Manual)	M52808600
Inlet knock out pot	M52809900
Inlet Press Ind Kit (pressure gauge)	M52808460
Inlet pressure transducer (for PID Control)	M52809200
Profibus module	P39753000
Pump mounting frame (for exhaust accessories)	M52808680
Solvent flush tank kit	M52808300

CXS250 chemical dry pump

Edwards pioneered the industrial dry vacuum pump in 1986 and now with more than 150,000 systems sold worldwide this Edwards expertise has been used to develop a dry pump capable of withstanding the harshest of process applications.

The CXS incorporates innovative screw design features with simplicity and reliability in mind, a 'Plug and Pump' philosophy has been adopted. As a result, the CXS has industry leading reliability, safety and low cost of ownership.



Features & Benefits

- Continuous vacuum from atmosphere to 10⁻³ mbar
- Integral temperature control
- Pumps corrosive vapours without deterioration
- Excellent liquid and solids handling
- Deeper vacuum than traditional technologies - not limited by seal fluid or cooling water temperature

Dimensions

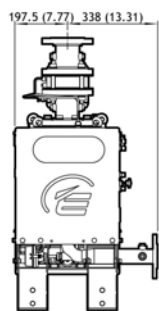

Front View

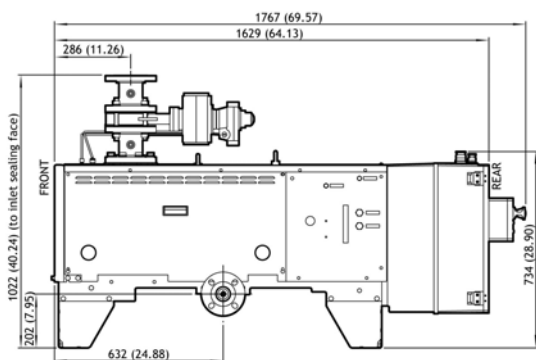

Left View

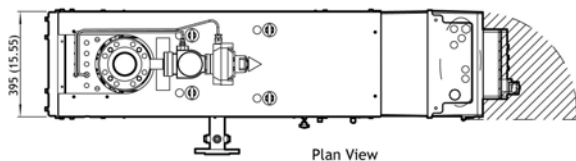

Plan View

Applications

- Drying
- Degassing
- Deodorisation
- Distillation
- Reactor service

Performance Curves

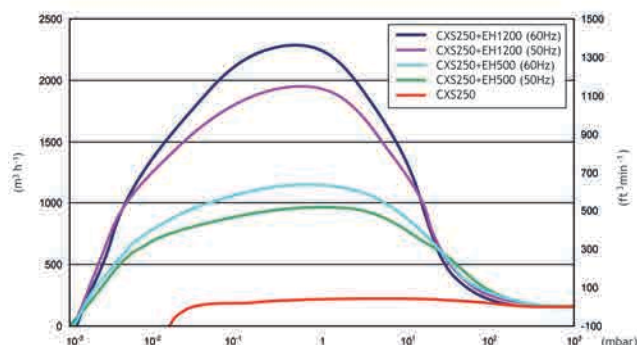

Technical Data

Maximum pumping speed	250 m ³ h ⁻¹ / 148 ft ³ min ⁻¹
Capacity at 10 mbar (7.5 Torr)	230 m ³ h ⁻¹ / 135 ft ³ min ⁻¹
Ultimate vacuum	<0.015 mbar / <0.011 Torr
Maximum back pressure - standard	1,200 mbar / 2.7 psig
Power consumption at 10 mbar (7.5 Torr)	3.8 kW / 5.1 hp
Standard motor	
(200 - 230V ±10%, 3 ph, 50/60 Hz)	7.5 kW
Standard motor	
(380 - 460V ±10%, 3 ph, 50/60 Hz)	10 hp
Cooling water flow rate, (adjustable)	4 - 10 l min ⁻¹ / 1.1 - 2.6 gal min ⁻¹
Cooling water temperature	
5 - 25 °C (41 - 77 °F) for T160 set-ups	5 - 35 °C / 41 - 95 °F
Max cooling water supply pressure	6.9 barg / 100 psig
Cooling water supply differential pressure	1.6 - 5.5 bar / 23 - 80 psi
Seal purge flow (max)	12 std l min ⁻¹ / 0.424 std ft ³ min ⁻¹
Seal purge supply pressure, (min - max)	2.5 - 6.9 barg / 36 - 100 psig
Noise (max) with silencer	64 dB(A)
Weight (with frame and standard motor)	470 kg / 1,034 lbs
Process connection, inlet	3"/DN80 ANSI/DIN
Process connection, outlet	2"/DN50 ANSI/DIN

Ordering Information

Product Description	Order No.
CXS250 ATEX CAT 2&3 T3 Light duty	CS956000000
CXS250 ATEX CAT 2&3 T3 Light duty, Knitmesh inlet & exhaust flame arrestors	CS956020000
CXS250 ATEX CAT 2&3 T3 Light duty, Protego inlet & exhaust flame arrestors	CS956070000
CXS250 ATEX CAT 2&3 T3 Medium duty+	CS956100500
CXS250 ATEX CAT 2&3 T3 Medium duty+, Knitmesh inlet & exhaust flame arrestors	CS956120500
CXS250 ATEX CAT 2&3 T3 Medium duty+, Protego inlet & exhaust flame arrestors	CS956170500
CXS250 ATEX CAT 2&3 T160 Light duty	CS957000000
CXS250 ATEX CAT 2&3 T160 Light duty, Knitmesh inlet & exhaust flame arrestors	CS957020000
CXS250 ATEX CAT 2&3 T160 Light duty, Protego inlet & exhaust flame arrestors	CS957070000
CXS250 ATEX CAT 2&3 T160 Medium duty+	CS957100500
CXS250 ATEX CAT 2&3 T160 Medium duty+, Knitmesh inlet & exhaust flame arrestors	CS957120500
CXS250 ATEX CAT 2&3 T160 Medium duty+, Protego inlet & exhaust flame arrestors	CS957170500
CXS250 ATEX CAT 1 T3 Light duty, Knitmesh inlet & exhaust flame arrestors	CS956620000
CXS250 ATEX CAT 1 T3 Light duty, Protego inlet & exhaust flame arrestors	CS956670000
CXS250 ATEX CAT 1 T3 Medium duty+, Knitmesh inlet & exhaust flame arrestors	CS956720500
CXS250 ATEX CAT 1 T3 Medium duty+, Protego inlet & exhaust flame arrestors	CS956770500
Accessories & Spares	Order No.
Exhaust condensor	M52808500
Exhaust flame arrestor kit Elmac (Knitmesh)	M52809100
Exhaust flame arrestor kit Protego	M52809140
Exhaust Press Ind Kit (pressure gauge)	M52808480
Exhaust silencer	M52808550
Exhaust valve kit(Manual)	M52808600
Inlet knock out pot	M52809900
Inlet Press Ind Kit (pressure gauge)	M52808460
Inlet pressure transducer (for PID Control)	M52809200
Profibus module	P39753000
Pump mounting frame (for exhaust accessories)	M52808680
Solvent flush tank kit	M52808300

CDX1000 Dry Vacuum Pump

Edwards CDX1000 represents the next generation of dry pump technology. The CDX1000 is a double ended mechanism for the chemical process, pharmaceutical and petrochemical industries.

This innovative technology leverages Edwards latest manufacturing and design philosophies. The CDX1000 is suited to larger processes where repeatability and reliability are key. Technologies and manufacturing techniques have been carefully selected to produce a robust, high performance machine that is simple to operate and maintain.



Features & Benefits

- Continuous performance from atmospheric pressures to ultimate vacuum
- Excellent temperature control
- Large liquid slug capabilities
- No effluent generated
- Dry running mechanism

Dimensions

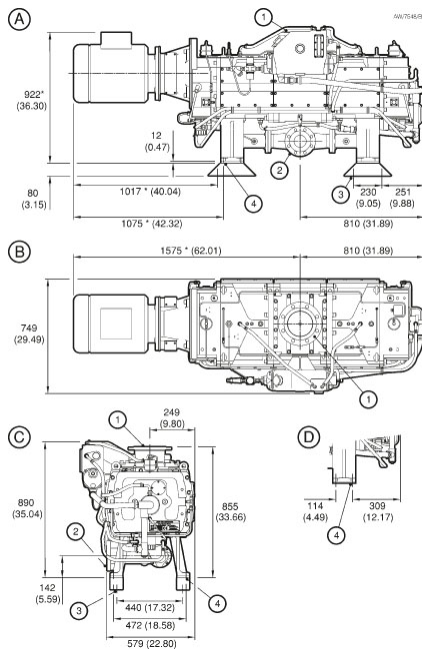

Note: this diagram shows a CDX with integral flame arrestors.

A Side view
B Plan view
C End view

D From fixing dimensions with mounting feet removed

1. Pump inlet
2. Pump outlet
3. Fixing holes Ø18 mm (0.71 inch), 2 holes on each mounting foot
4. Fixing holes Ø17 mm (0.67 inch), 2 holes on each mounting bracket

Applications

- Processes
- Distillation
- Drying
- Evaporation/Crystallisation
- Solvent/Vapour Recovery

Performance Curves

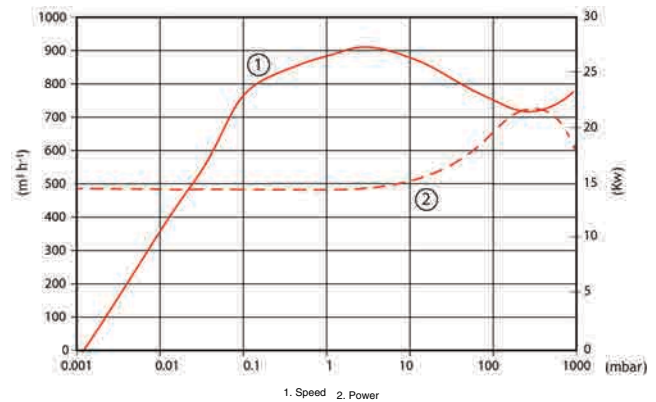

Technical Data

Maximum pumping speed	900 m ³ h ⁻¹ 530 ft ³ min ⁻¹
Capacity at 10 mbar (7.5 Torr)	900 m ³ h ⁻¹ 530 ft ³ min ⁻¹
Ultimate vacuum	5 x 10 ⁻³ mbar 4 x 10 ⁻³ Torr
Maximum back pressure - standard (optional*)	1150 mbarA 2.0 psig
Power consumption at 10 mbar (7.5 Torr)	17.1 kW 23.2 Hp
Standard motor(380 - 400V, 3 ph, 50 Hz)	30 kW
Standard motor(200 - 460V, 3 ph, 60 Hz)	40 hp
Cooling water flow rate (adjustable)	10 – 20 lmin ⁻¹ 2.64 - 5.28 galmin ⁻¹
Cooling water supply temperature range	5 - 35 °C / 41 - 95 °F
Cooling water supply pressure	2 – 10 barg 29 – 145 psig
Seal purge flow (maximum), regulated to 0.3 - 0.5 barg, (5 - 7 psig)	24 l min ⁻¹ 0.85 ft ³ min ⁻¹
Seal purge supply pressure(minimum - maximum)	2 – 10 barg 29 – 145 psig
Noise (max. with exhaust silencer)	82 dB(A)
Weight (with frame and standard motor)	1710 kg 3765 lbs
Process connection, inlet	6" ANSI/DN150
Process connection, outlet	3" ANSI/DN80
Pumping mechanism	

* Consult Edwards

Ordering Information

Product Description	Order No.
CDX1000, 30kW, 50 Hz, Flame Proof with Integral Flame Arrestors	A70801985
CDX1000 Dry Vacuum Pump, 30kW, 50 Hz, Flame Proof (without Integral Flame Arrestors)	A70802985
CDX1000 Dry Vacuum Pump, 40 HP, 60 Hz, Flame Proof with Integral Flame Arrestors	A70811985
CDX1000 Dry Vacuum Pump, 40 HP, 60 Hz, Flame Proof (without Integral Flame Arrestors)	A70812985
Accessories & Spares	Order No.
Gear Box Oil 4 Ltr Mobil SHC 629	H11023011
Coolant 0.9/2L Drystar	H12810003
IDX Routine maintenance kit	A70801800
IDX Heat exchanger cleaning kit	A70801801
IDX Cooling system overhaul kit	A70801802
IDX Motor fitting kit	A70801803
IDX Drive coupling kit	A70801804
IDX Bearing and seal replacement kit	A70801805
IDX Oil pump replacement kit	A70801806
IDX Strip and rebuild kit	A70801807
IDX Flame arrestor cleaning kit	A70801808
IDX Hoses kit	A70801809
IDX Flame arrestor replacement kit (inlet)	A70801810
IDX Flame arrestor replacement kit (outlet)	A70801811
IDX Flame arrestor tooling kit	A70801812

EDP80 - Dry Chemical Pumps

EDP pumps are based on Edwards' oil-free, non-contacting, award-winning, reverse claw mechanism. They provide consistent vacuum at high efficiencies and low costs of ownership. Dry pumps completely eliminate all problems of process contamination and creation of polluted effluent, which are experienced with traditional wet vacuum pump technologies.



Features & Benefits

- Staged compression for optimum temperature profile within the pump and no requirement for cooling gas injection
- Inherently free draining
- Able to handle liquid or particulate carryover
- Short gas path eliminates particulate build-up and corrosion - Edwards' patented design
- Can flush with solvents, water or steam

Applications

- Drying
- Distillation
- Reactor service
- Solvent recovery
- House/Central vacuum

Dimensions

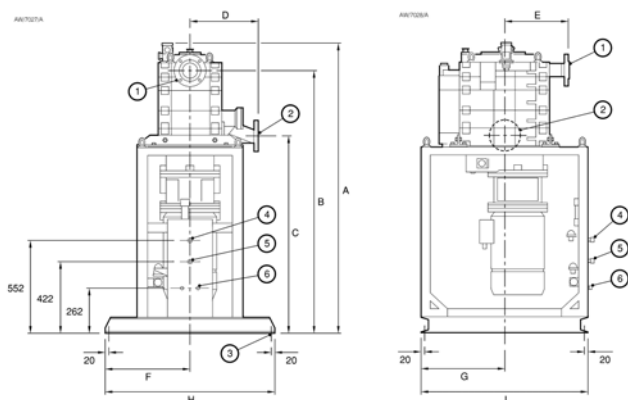

EDP80	A	B	C	D	E	F	G	H	I
	1423	1254	974	353	443	350	350	700	850
	(56.0)	(49.4)	(38.3)	(13.9)	(17.4)	(13.8)	(13.8)	(27.6)	(33.5)

1. Pump inlet
2. Pump outlet
3. Fixing hole: Ø18 mm (4 off)
4. Cooling water outlet connection
5. Cooling water inlet connection
6. Nitrogen supply inlet connection

Performance Curves

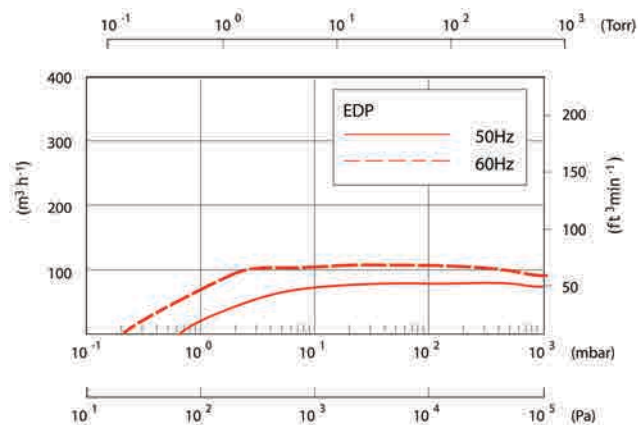

Technical Data

Maximum pumping speed	
50 Hz	83 m ³ h ⁻¹ / 49 ft ³ min ⁻¹
60 Hz	102 m ³ h ⁻¹ / 60 ft ³ min ⁻¹
Capacity at 10 mbar (7.5 Torr)	
50 Hz	75 m ³ h ⁻¹ / 44 ft ³ min ⁻¹
60 Hz	102 m ³ h ⁻¹ / 60 ft ³ min ⁻¹
Ultimate vacuum	
50 Hz	0.5 mbar / 0.4 Torr
60 Hz	0.3 mbar / 0.2 Torr
Maximum back pressure	
Standard	1150 mbar / 2.2 psig
Optional*	1300 mbar / 4.4 psig
Power consumption at 10 mbar (7.5 Torr)	
50 Hz	3.3 kW / 4.4 hp
60 Hz	4.0 kW / 5.4 hp
Standard motor (380 – 400 V, 3 ph, 50 Hz)	5.5 kW
Standard motor (200 – 460 V, 3 ph, 60 Hz)	7.5 hp
Cooling water flow rate (adjustable)	
50 Hz	1 – 8 lmin ⁻¹ / 0.3 – 2.1 galmin ⁻¹
60 Hz	1 – 10 lmin ⁻¹ / 0.3 – 2.6 galmin ⁻¹
Cooling water supply pressure	2 – 10 barg / 29 – 145 psig
Seal purge flow (maximum), regulated to 0.3 - 0.5 barg (5 – 7 psig)	20 l min ⁻¹ / 0.7 ft ³ min ⁻¹
Seal purge supply pressure (minimum - maximum)	2 – 10 barg / 29 – 145 psig
Noise (max. with exhaust silencer)	73 dB(A)
Weight (with frame and standard motor)	
50 Hz	648 kg / 1429 lbs
60 Hz	650 kg / 1433 lbs
Inlet	2" ANSI / DN50
Outlet	1.5" ANSI / DN40
Pumping mechanism	3 stage reversed claw

* Consult Edwards

Ordering Information

Product Description	Order No.
EDP80 50Hz, Bareshaft Pump	A70545000
EDP80 60Hz, Bareshaft Pump	A70547000
Accessories & Spares	Order No.
Spares Kit Routine Maintenance DP	A70501825
Spares Kit Motor Fitment DP	A70501805
Spares Kit Upper Bearing DP	A70501826
Spares Kit Swept Volume DP	A70501827
Spares Kit Lower Bearing DP	A70501828
Std Replacement PRV DP	A70501816
Bellows Replacement PRV DP	A70501820
Swing PRV Chemical	A70501832
Spares Kit Bellows Overhaul DP	A70501829
Spares Kit O Ring DP	A70501821
Spares Kit Std PRV Overhaul DP	A70501831
Spares Kit Swing PRV Overhaul Chemical	A70501833
DP250/EDP200 Clutch Tools	A21071082

EDP160 - Dry Chemical Pumps

EDP pumps are based on Edwards' oil-free, non-contacting, award-winning, reverse claw mechanism. They provide consistent vacuum at high efficiencies and low costs of ownership. Dry pumps completely eliminate all problems of process contamination and creation of polluted effluent, which are experienced with traditional wet vacuum pump technologies.



Features & Benefits

- Staged compression for optimum temperature profile within the pump and no requirement for cooling gas injection
- Inherently free draining
- Able to handle liquid or particulate carryover
- Short gas path eliminates particulate build-up and corrosion - Edwards' patented design
- Can flush with solvents, water or steam

Applications

- Drying
- Distillation
- Reactor service
- Solvent recovery
- House/Central vacuum

Dimensions

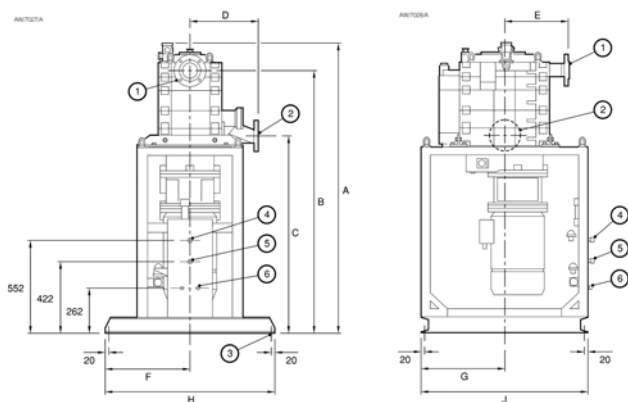

EDP160	A	B	C	D	E	F	G	H	I
	1423	1254	974	353	443	350	350	700	850
	(56.0)	(49.4)	(38.3)	(13.9)	(17.4)	(13.8)	(13.8)	(27.6)	(33.5)

1. Pump inlet
2. Pump outlet
3. Fixing hole: Ø18 mm (4 off)
4. Cooling water outlet connection
5. Cooling water inlet connection
6. Nitrogen supply inlet connection

Performance Curves

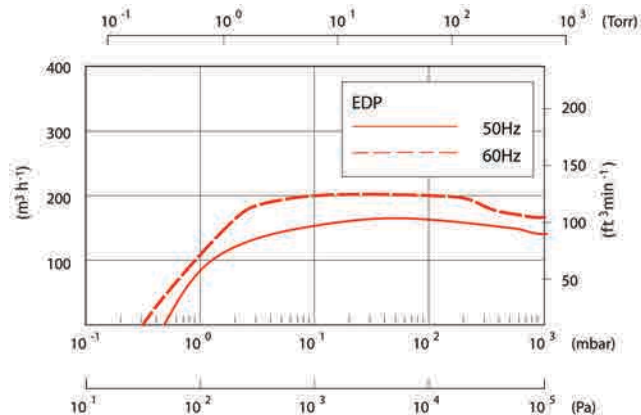

Technical Data

Maximum pumping speed	
50 Hz	163 m ³ h ⁻¹ / 96 ft ³ min ⁻¹
60 Hz	202 m ³ h ⁻¹ / 119 ft ³ min ⁻¹
Capacity at 10 mbar (7.5 Torr)	
50 Hz	153 m ³ h ⁻¹ / 90 ft ³ min ⁻¹
60 Hz	198 m ³ h ⁻¹ / 117 ft ³ min ⁻¹
Ultimate vacuum	
50 Hz	0.5 mbar / 0.4 Torr
60 Hz	0.3 mbar / 0.2 Torr
Maximum back pressure	
Standard	1150 mbar / 2.2 psig
Optional*	1300 mbar / 4.4 psig
Power consumption at 10 mbar (7.5 Torr)	
50 Hz	4.9 kW / 6.6 hp
60 Hz	4.9 kW / 6.6 hp
Standard motor (380 – 400 V, 3 ph, 50 Hz)	7.5 kW
Standard motor (200 – 460 V, 3 ph, 60 Hz)	11 hp
Cooling water flow rate (adjustable)	
50 Hz	1 – 8 lmin ⁻¹ / 0.3 – 2.1 galmin ⁻¹
60 Hz	1 – 10 lmin ⁻¹ / 0.3 – 2.6 galmin ⁻¹
Cooling water supply pressure	2 – 10 barg / 29 – 145 psig
Seal purge flow (maximum), regulated to 0.3 - 0.5 barg (5 – 7 psig)	20 lmin ⁻¹ / 0.7 ft ³ min ⁻¹
Seal purge supply pressure (minimum - maximum)	2 – 10 barg / 29 – 145 psig
Noise (max. with exhaust silencer)	78 dB(A)
Weight (with frame and standard motor)	
50 Hz	747 kg / 1647 lbs
60 Hz	756 kg / 1667 lbs
Inlet	3 ANSI / DN80
Outlet	1.5 ANSI / DN40
Pumping mechanism	3 stage reversed claw

* Consult Edwards

Ordering Information

Product Description	Order No.
EDP160 50Hz, Bareshaft Pump	A70544000
EDP160 60Hz, Bareshaft Pump	A70546000
Accessories & Spares	Order No.
Spares Kit Routine Maintenance DP	A70501825
Spares Kit Motor Fitment DP	A70501805
Spares Kit Upper Bearing DP	A70501826
Spares Kit Swept Volume DP	A70501827
Spares Kit Lower Bearing DP	A70501828
Std Replacement PRV DP	A70501816
Bellows Replacement PRV DP	A70501820
Swing PRV Chemical	A70501832
Spares Kit Bellows Overhaul DP	A70501829
Spares Kit O Ring DP	A70501821
Spares Kit Std PRV Overhaul DP	A70501831
Spares Kit Swing PRV Overhaul Chemical	A70501833
DP250/EDP200 Clutch Tools	A21071082

EDP250 - Dry Chemical Pumps

EDP pumps are based on Edwards' oil-free, non-contacting, award-winning, reverse claw mechanism. They provide consistent vacuum at high efficiencies and low costs of ownership. Dry pumps completely eliminate all problems of process contamination and creation of polluted effluent, which are experienced with traditional wet vacuum pump technologies.



Features & Benefits

- Staged compression for optimum temperature profile within the pump and no requirement for cooling gas injection
- Inherently free draining
- Able to handle liquid or particulate carryover
- Short gas path eliminates particulate build-up and corrosion - Edwards' patented design
- Can flush with solvents, water or steam

Applications

- Drying
- Distillation
- Reactor service
- Solvent recovery
- House/Central vacuum

Dimensions

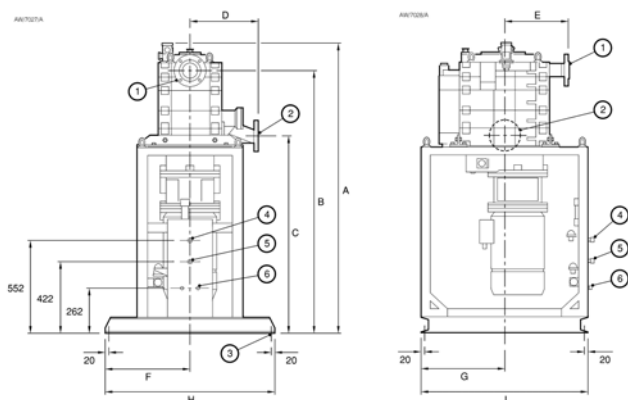

EDP250	A	B	C	D	E	F	G	H	I
	1423	1254	974	353	443	350	350	700	850
	(56.0)	(49.4)	(38.3)	(13.9)	(17.4)	(13.8)	(13.8)	(27.6)	(33.5)

1. Pump inlet
2. Pump outlet
3. Fixing hole: Ø18 mm (4 off)
4. Cooling water outlet connection
5. Cooling water inlet connection
6. Nitrogen supply inlet connection

Performance Curves

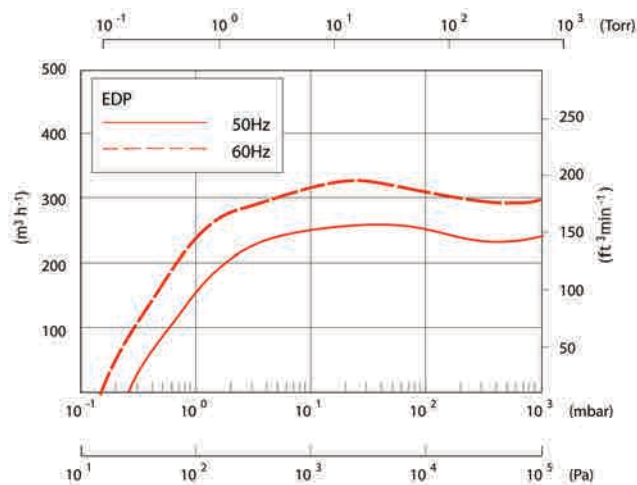

Technical Data

Maximum pumping speed	
50 Hz	260 m ³ h ⁻¹ / 320 ft ³ min ⁻¹
60 Hz	153 m ³ h ⁻¹ / 188 ft ³ min ⁻¹
Capacity at 10 mbar (7.5 Torr)	
50 Hz	255 m ³ h ⁻¹ / 150 ft ³ min ⁻¹
50 Hz	315 m ³ h ⁻¹ / 185 ft ³ min ⁻¹
Ultimate vacuum	
50 Hz	0.5 mbar / 0.4 Torr
60 Hz	0.2 mbar / 0.2 Torr
Maximum back pressure	
Standard	1150 mbar / 2.2 psig
Optional*	1300 mbar / 4.4 psig
Power consumption at 10 mbar (7.5 Torr)	
50 Hz	6.0 kW / 8.0 hp
60 Hz	6.0 kW / 8.0 hp
Standard motor (380 – 400 V, 3 ph, 50 Hz)	
50 Hz	11 kW
60 Hz	15 kW
Standard motor (200 – 460 V, 3 ph, 60 Hz)	
50 Hz	15 hp
60 Hz	20 hp
Cooling water flow rate (adjustable)	
50 Hz	1 – 10 lmin ⁻¹ / 0.3 – 2.6 galmin ⁻¹
60 Hz	1 – 10 lmin ⁻¹ / 0.3 – 2.6 galmin ⁻¹
Cooling water supply pressure	2 – 10 barg / 29 – 145 psig
Seal purge flow (maximum), regulated to 0.3 - 0.5 barg (5 – 7 psig)	20 lmin ⁻¹ / 0.7 ft ³ min ⁻¹
Seal purge supply pressure (minimum - maximum)	2 – 10 barg / 29 – 145 psig
Noise (max. with exhaust silencer)	
50 Hz	78 dB(A)
60 Hz	79 dB(A)
Weight (with frame and standard motor)	
50 Hz	756 kg / 1667 lbs
60 Hz	848 kg / 1870 lbs
Inlet	3 ANSI / DN80
Outlet	1.5 ANSI / DN40
Pumping mechanism	3 stage reversed claw

* Consult Edwards

Ordering Information

Product Description	Order No.
EDP250 50/60Hz, Bareshaft Pump	A70543000
Accessories & Spares	Order No.
Spares Kit Routine Maintenance DP	A70501825
Spares Kit Motor Fitment DP	A70501805
Spares Kit Upper Bearing DP	A70501826
Spares Kit Swept Volume DP	A70501827
Spares Kit Lower Bearing DP	A70501828
Std Replacement PRV DP	A70501816
Bellows Replacement PRV DP	A70501820
Swing PRV Chemical	A70501832
Spares Kit Bellows Overhaul DP	A70501829
Spares Kit O Ring DP	A70501821
Spares Kit Std PRV Overhaul DP	A70501831
Spares Kit Swing PRV Overhaul Chemical	A70501833
DP250/EDP200 Clutch Tools	A21071082

EDP400 - Dry Chemical Pumps

EDP pumps are based on Edwards' oil-free, non-contacting, award-winning, reverse claw mechanism. They provide consistent vacuum at high efficiencies and low costs of ownership. Dry pumps completely eliminate all problems of process contamination and creation of polluted effluent, which are experienced with traditional wet vacuum pump technologies.



Features & Benefits

- Staged compression for optimum temperature profile within the pump and no requirement for cooling gas injection
- Inherently free draining
- Able to handle liquid or particulate carryover
- Short gas path eliminates particulate build-up and corrosion - Edwards' patented design
- Can flush with solvents, water or steam

Applications

- Drying
- Distillation
- Reactor service
- Solvent recovery
- House/Central vacuum

Dimensions

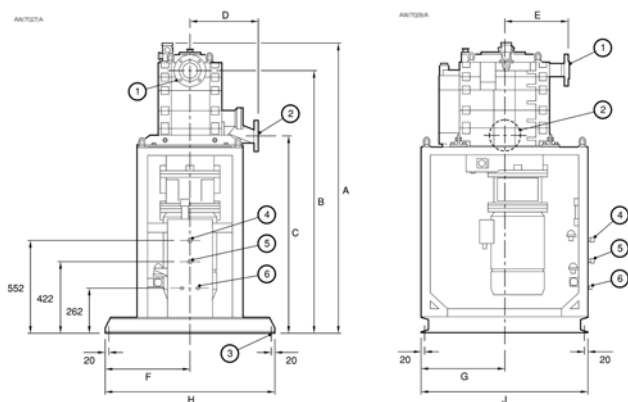

EDP400	A	B	C	D	E	F	G	H	J
50Hz	1721	1549	1149	349	362	476	476	997	946
(60 Hz)	(67.8)	(61.0)	(45.2)	(13.7)	(14.3)	(18.7)	(18.7)	(39.3)	(37.2)

1. Pump inlet
2. Pump outlet
3. Fixing holes: Ø18 mm (4 off)
4. Cooling water outlet connection
5. Cooling water inlet connection
6. Nitrogen supply inlet connection

Performance Curves

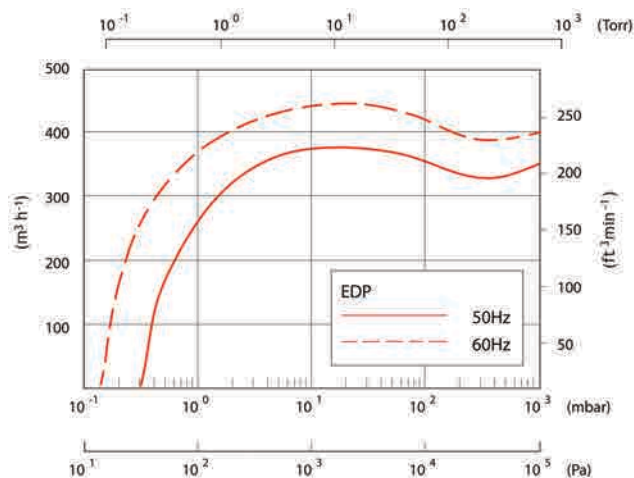

Technical Data

Maximum pumping speed	
50 Hz	377 m ³ h ⁻¹ / 222 ft ³ min ⁻¹
60 Hz	427 m ³ h ⁻¹ / 251 ft ³ min ⁻¹
Capacity at 10 mbar (7.5 Torr)	
50 Hz	377 m ³ h ⁻¹ / 222 ft ³ min ⁻¹
50 Hz	422 m ³ h ⁻¹ / 248 ft ³ min ⁻¹
Ultimate vacuum	
50 Hz	0.4 mbar / 0.3 Torr
60 Hz	0.2 mbar / 0.2 Torr
Maximum back pressure	
Standard	1150 mbar / 2.2 psig
Power consumption at 10 mbar (7.5 Torr)	
50 Hz	7.0 kW / 9.4 hp
60 Hz	7.0 kW / 9.4 hp
Standard motor (380 – 400 V, 3 ph, 50 Hz)	
50 Hz	18.5 kW
60 Hz	25.0 kW
Standard motor (200 – 460 V, 3 ph, 60 Hz)	
50 Hz	25.0 hp
60 Hz	30.0 hp
Cooling water flow rate (adjustable)	
50 Hz	1 – 10 lmin ⁻¹ / 0.3 – 2.6 galmin ⁻¹
60 Hz	1 – 10 lmin ⁻¹ / 0.3 – 2.7 galmin ⁻¹
Cooling water supply pressure	2 – 10 barg / 29 – 145 psig
Seal purge flow (maximum), regulated to 0.3 - 0.5 barg (5 – 7 psig)	20 lmin ⁻¹ / 0.7 ft ³ min ⁻¹
Seal purge supply pressure (minimum - maximum)	2 – 10 barg / 29 – 145 psig
Noise (max. with exhaust silencer)	
50 Hz	82 dB(A)
60 Hz	82 dB(A)
Weight (with frame and standard motor)	
50 Hz	918 kg / 2024 lbs
60 Hz	960 kg / 2116 lbs
Inlet	3 ANSI / DN80
Outlet	1.5 ANSI / DN40
Pumping mechanism	3 stage reversed claw

* Consult Edwards

Ordering Information

Product Description	Order No.
EDP400 50 Hz, Bareshaft Pump	A70542000
EDP400 60 Hz, Bareshaft Pump	A70541000
Accessories & Spares	Order No.
Spares Kit Routine Maintenance DP	A70501825
Spares Kit Motor Fitment DP	A70501805
Spares Kit Upper Bearing DP	A70501826
Spares Kit Swept Volume DP	A70501827
Spares Kit Lower Bearing DP	A70501828
Std Replacement PRV DP	A70501816
Bellows Replacement PRV DP	A70501820
Swing PRV Chemical	A70501832
Spares Kit Bellows Overhaul DP	A70501829
Spares Kit O Ring DP	A70501821
Spares Kit Std PRV Overhaul DP	A70501831
Spares Kit Swing PRV Overhaul Chemical	A70501833
DP250/EDP200 Clutch Tools	A21071082

Liquid Ring Pumps

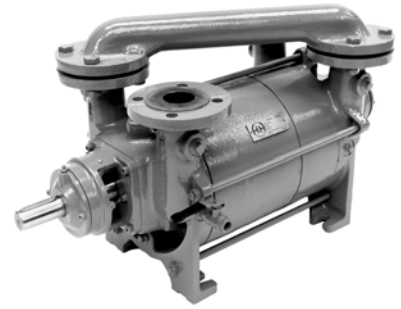
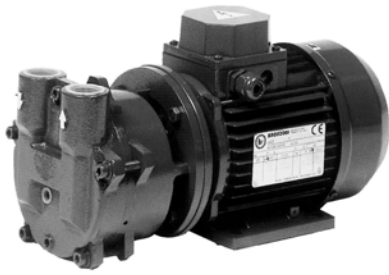

HR Series Liquid Ring Pumps

404

LR1A Liquid Ring Pumps

412

LR1B Liquid Ring Pumps

433

Liquid Ring Vacuum Pumps



Liquid ring vacuum pumps continue to provide the optimum solution for many rough vacuum applications in the chemical and allied process industries. The general reliability, low maintenance requirements, low vibration and noise levels coupled with the unique capabilities when handling wet gases all contribute to the popularity of the pump.

Operating Range

Liquid ring pumps are suitable for continuous operation on vacuum applications at any suction pressure down to 30 mbar A. Standard performance data is based upon 15 °C water as the seal liquid, lower pressures may be possible with alternative sealing liquid.

A wide range of capacities are offered from two basic pump configurations, single and two stages.

Liquid Ring Vacuum Pump Range

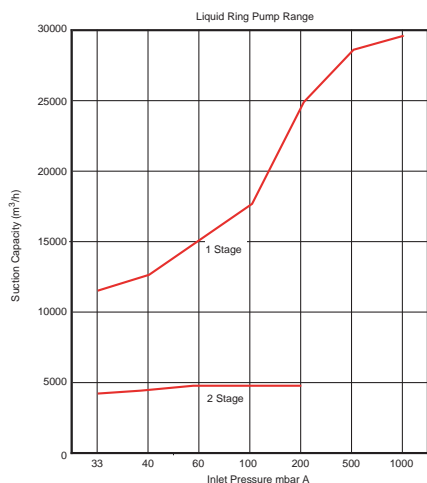

The single stage range is capable of operation at 30 mbar A where required, but is most suited to applications with continuous operation at inlet pressures from atmospheric down to 100 mbar A. The smallest pump in the range is a 25 m³h⁻¹ close coupled model while the largest has a nominal capacity of 30000 m³h⁻¹.

The two-stage range is most effective on applications with continuous operation below 100 mbar A and has models from 50 up to 5000 m³h⁻¹. Detailed performance data is shown on the following pages.

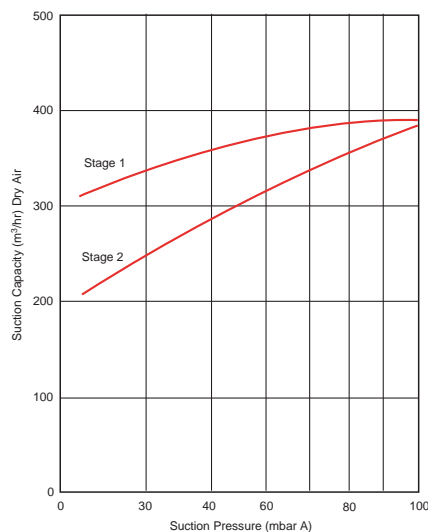

Comparison of Single and two stage performance

Materials of Construction

The standard construction material is cast iron with either a spheroidal graphite or bronze impeller depending upon the series. One of the main features of the liquid ring pump is the availability of various alternative materials of construction. The main options are stainless steel, aluminium bronze, and duplex stainless steels. Some pump sizes, which are particularly suited to the pharmaceutical industry, are also available in hastelloy.

For details on material availability please contact your local sales office.

How It Works

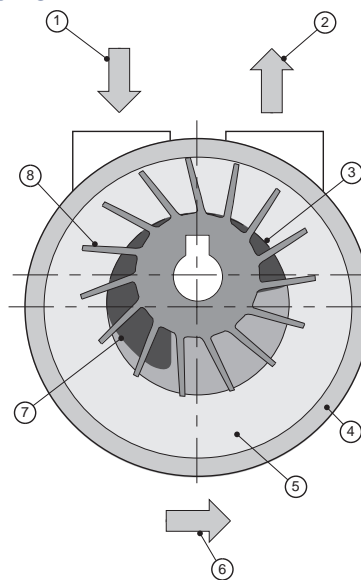

- | | |
|------------------|-------------------------|
| 1 Suction | 5 Sealing ring |
| 2 Discharge | 6 Direction of rotation |
| 3 Discharge port | 7 Suction port |
| 4 Casting | 8 Impeller |

The impeller is mounted eccentrically to the axis of the pump casing, the liquid ring circulates concentrically within the axis of the casing. Process gases are drawn through the inlet port into the impeller cells where the gas is compressed and discharged through the discharge port. The seal liquid which forms the liquid ring is supplied at a pressure equal to the discharge pressure of the pump, which allows the pump to automatically make up the amount of liquid which is discharged through the discharge port, therefore removing the heat of compression from the pump.

Applications

Some of the more common processes which utilise liquid ring technology are listed below.

- Distillation
- Filtration
- Evaporation
- Drying
- Stripping
- Solvent recovery
- Deaeration

These processes are used in a wide range of industries and applications, which include:

- Chemical processing
- Food processing and packaging
- Pharmaceutical production
- Oil exploration and refining
- Glass industry
- Tobacco conditioning
- Packaging
- Electronics industry
- Automobile components
- Power generation
- Waste collection
- Building materials
- Soil remediation

Systems

Liquid ring pumps are offered in a number of standard configurations, with a selection of seal liquid systems to suit the particular application and environment.

SLRP Configurator

The SLRP system utilizes 3D AutoCAD design software to produce a tailored liquid ring pump package constructed from pre-engineered modules. The main benefits being the instant availability of a customized quotation and package general arrangement drawing and reduced lead times.

The system offers a selection of pump material options along with a choice from three standard operating configurations to suit the process conditions.

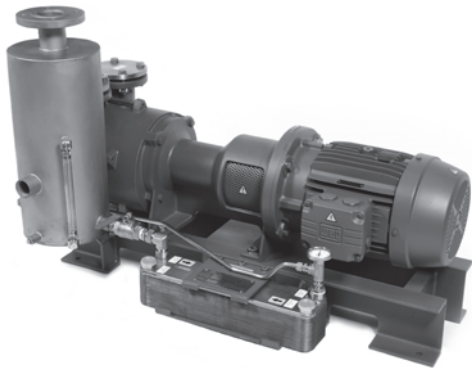

Once-Through

This is the most basic configuration available, it comprises of a pump complete with electric motor and drive and base frame. A discharge separator is required at the pump discharge. It is used where an ample supply of seal liquid, which can be subsequently discharged to drain, is available. The liquid/gas mixture is discharged to drain through the discharge line.

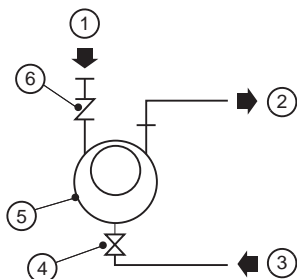

- | | |
|------------------------------|-----------------------------------|
| 1 Process gas inlet | 4 Regulating valve |
| 2 Fluid gas mixture to drain | 5 Edwards liquid ring vacuum pump |
| 3 Sea fluid | 6 Check valve |

Partial Recirculation

In this case, the liquid/gas mixture is separated in the discharge separator. The recovered service liquid is then mixed with fresh seal fluid to maintain a constant temperature to the pump. The excess liquid, equivalent to the make-up supply, goes to drain. The minimum amount of fresh make-up fluid is used to ensure cavitation free operation at the required suction pressure.

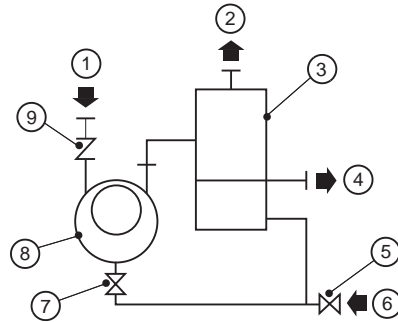

- | | |
|----------------------------|-----------------------------------|
| 1 Process gas inlet | 6 Make-up fluid |
| 2 Gas vent | 7 Manual control valve |
| 3 Discharge separator | 8 Edwards liquid ring vacuum pump |
| 4 30% - 70% fluid to drain | 9 Check valve |
| 5 Seal fluid make-up valve | |

Total Recirculation

Total recirculation is used where it is desirable to minimise waste liquid from the pump. All of the liquid is re-circulated back into the pump via a heat exchanger, which removes the heat of compression and any latent heat of condensation from the seal liquid. The seal liquid can then be reused by the pump minimising the effluent from the pump system. The system is of particular interest when the pump is operating on a solvent removal or drying process where process vapours are condensed within the pump, often the pump seal liquid can be the same as the condensed process vapours.

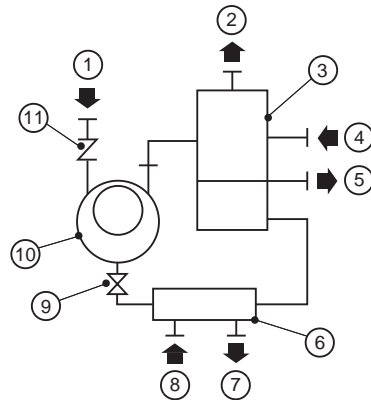

- | | |
|---------------------------|------------------------------------|
| 1 Process gas inlet | 7 Cooling liquid out |
| 2 Gas vent | 8 Cooling liquid in |
| 3 Discharge separator | 9 Manual control valve |
| 4 Make-up fluid | 10 Edwards liquid ring vacuum pump |
| 5 Fluid overflow to drain | 11 Check valve |
| 6 Heat exchanger | |

Standard Accessories

A range of accessories to complement the standard package are available, these can be selected in the configurator:

- Inlet non-return valve
- Inlet isolating valve
- Inlet vacuum gauge
- Vacuum relief valve
- Automatic seal water make up kit

The SLRP package is available for the following pump sizes:

50 Hz

	RPM	kW	m ³ h ⁻¹	Inlet mm
SIZE 1				
LR1L90	1450	2.2	69	40
LR1L125	1450	3	111	40
LR1L150	1450	4	142	40
LR2S100	1450	3	91	40
LR2S150	1450	4	128	40
LR2S200	1450	5.5	170	40
SIZE 2				
LR1L250	1450	5.5	69	65
LR1L320	1450	7.5	111	65
LR1L450	1450	11	142	65
LR2S275	1450	7.5	244	50
LR2S350	1450	11	340	50
LR2S425	1450	15	368	50
SIZE 3				
LR1S600	1450	15	540	100
LR1S800	1450	22	790	100
LR2S600	1450	18.5	596	80
LR2S750	1450	30	640	80

60 Hz

	RPM	HP	ft ³ min ⁻¹	Inlet inch
SIZE 1				
LR1L90	1750	5	59	1.5
LR1L125	1750	7.5	70	1.5
LR1L150	1750	7.5	94	1.5
LR2S100	1750	7.5	59	1.5
LR2S150	1750	10	88	1.5
LR2S200	1750	10	118	1.5
SIZE 2				
LR1L250	1750	10	129	2.5
LR1L320	1750	15	194	2.5
LR1L450	1750	20	258	2.5
LR2S275	1750	15	162	2.0
LR2S350	1750	20	235	2.0
LR2S425	1750	25	265	2.0
SIZE 3				
LR1S600	1750	30	367	4
LR1S800	1750	40	529	4
LR2S600	1750	40	383	3
LR2S750	1750	50	640	3

Hazardous Areas

The SLRP packages and accessories are available certified for hazardous area operation:

- European ATEX Ex II 2Gc, IIB T3
- USA Explosion proof Class 1 Division 1 Group C & D
- Packages suitable for operation in other zones such as ATEX Cat 1 are available on request.

Non Standard Packages

More complex systems include special recirculation systems such as the Recovac package (see later) or combinations of liquid ring pumps with roots type mechanical boosters or air, gas or steam ejectors. These hybrid systems can extend the liquid ring pump based performance envelope significantly.

Liquid Ring Pump Applications in Power Market

Liquid ring pumps are ideally suited for use in a number of vacuum applications in power generation, all of which benefit from the performance characteristics of liquid ring vacuum pumps.

- Condenser Air Extraction
- Waterbox Priming
- Flue Gas Desulphurisation
- Fly Ash Handling

Condenser air extraction and waterbox priming both contribute to increased efficiency of the power plant, whilst flue gas desulphurisation and fly ash handling are both to do with treatment of the boiler exhaust gas.

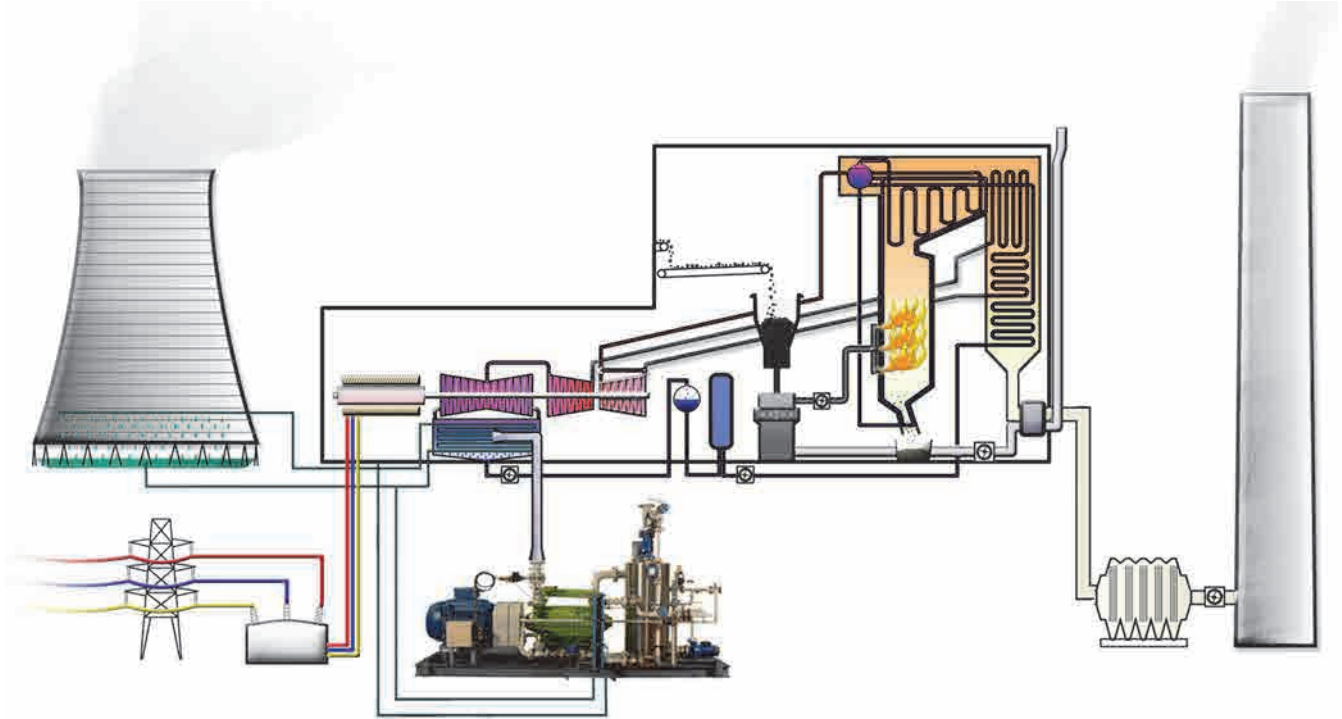

Typical coal fired power plant

Edwards have developed a range of standard pump packages to meet the vacuum pumping requirements for each of these applications.

Condenser Air Extraction

In order to increase the availability, operational performance and reliability of turbine condenser vacuum plants, the dynamic relationship between the vacuum pumping system, condenser performance and turbine back pressure is an important factor in the design requirements and needs careful appraisal when considering overall plant performance.

Selection of the vacuum equipment is usually based upon a theoretical condition, with performance requirements taken from HEI (or VGB) recommendations. Client specifications require further analysis of pump performance at actual operating temperatures and pressures, including part load and operation with alternate fuels.

Edwards condenser air extraction packages, based on two-stage liquid ring vacuum pumps, are designed to remove system air leakage from steam turbine generator surface condensers systems, helping the turbine efficiency to be maintained. This is achieved by reducing the pressure in the turbine, enabling more heat from the steam to be converted to mechanical energy, thereby increasing the output of the power plant.

The air load from the turbine condenser system is saturated with vapour: liquid ring pumps are ideal for handling high vapour loads as much of the vapour will be condensed at the pump suction (by the direct condensing action of the inlet water spray or contact with the pump seal water). This condensing reduces the total volume to be handled by the pump, which is a significant advantage when compared to other pumping technologies.

Edwards have developed a range of standard packages based upon the SHR series of two stage liquid ring pumps. The packages are designed to meet air leakage rates in the HEI Standards for Steam Surface Condensers.

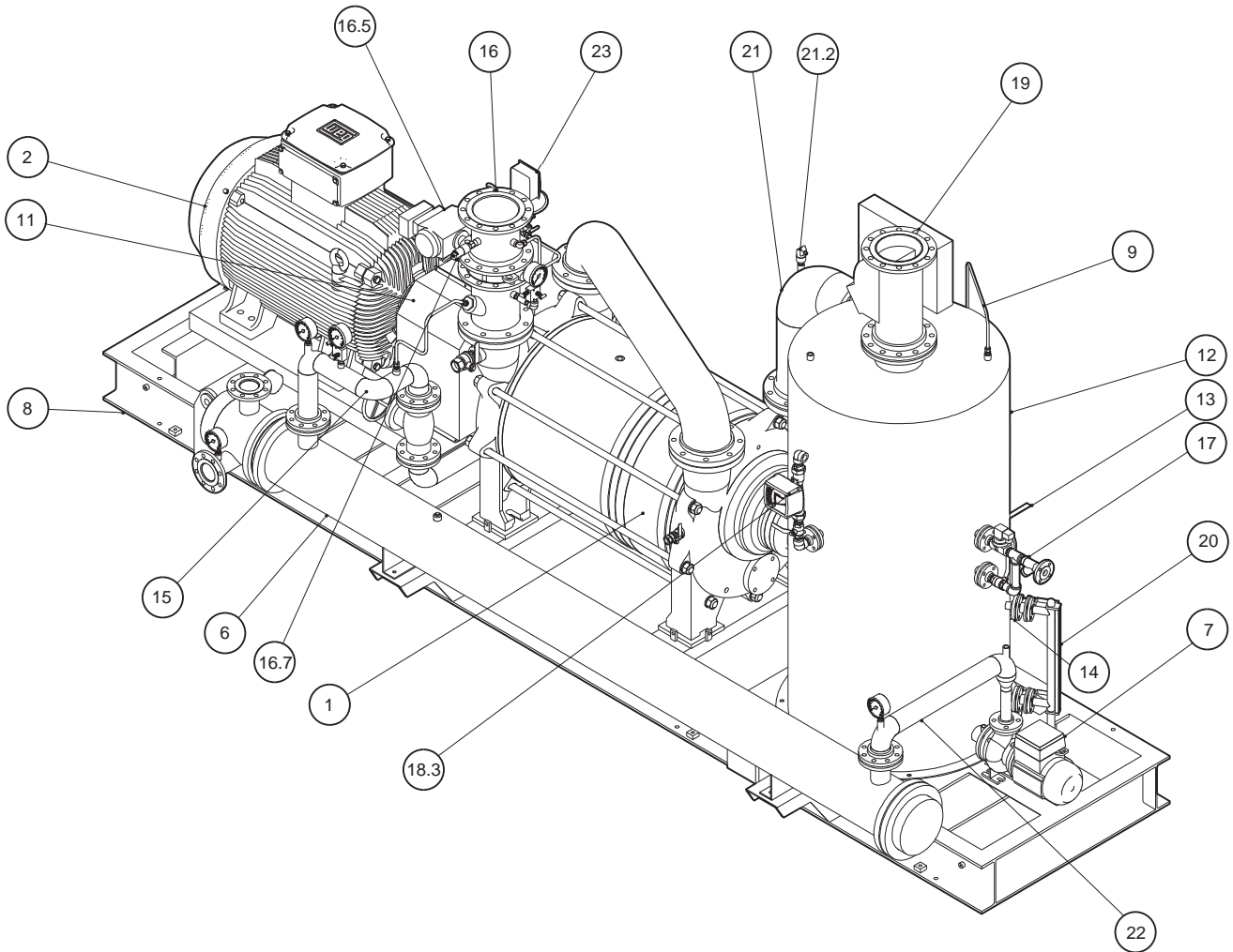

Liquid ring pumps are very effective when pumping wet gases and condensable vapours and are able to operate across the entire pressure range from atmospheric pressure to less than 1 inch Hgabs, this gives maximum flexibility in meeting the required condenser backing pressure under various operating conditions. A guide to pump selection can be seen in the table below, this shows the pump size required to achieve 1 inch Hgabs with varying ITD's (Initial Temperature Difference) between the condenser cooling water and the condenser outlet temperature. For more information on pump performance against specific operating conditions, please contact your local customer care office.

HEI / Liquid Ring Pump Selection Chart at 33.86 mbar A with Varying Condenser ITD

ITD HEI SCFM	10 °C	11 °C	13 °C	15 °C	17 °C
5	SHR2750	SHR2400	SHR2400	SHR2400	SHR2400
7.5	SHR2950	SHR2750	SHR2750	SHR2400	SHR2400
10	SHR2950	SHR2950	SHR2750	SHR2750	SHR2750
12.5	SHR2950	SHR2950	SHR2950	SHR2750	SHR2750
15	SHR21200	SHR21200	SHR2950	SHR2950	SHR2950
17.5	SHR21850	SHR21200	SHR21200	SHR2950	SHR2950
20	SHR21850	SHR21850	SHR21200	SHR21200	SHR2950
25	SHR22500	SHR21850	SHR21850	SHR21200	SHR21200
30	SHR22500	SHR22500	SHR21850	SHR21850	SHR21850
40	SHR22500	SHR22500	SHR22500	SHR22500	SHR21850

The standard package includes all of the associated equipment required to operate the pump package, including the transition from hogging to holding duty.

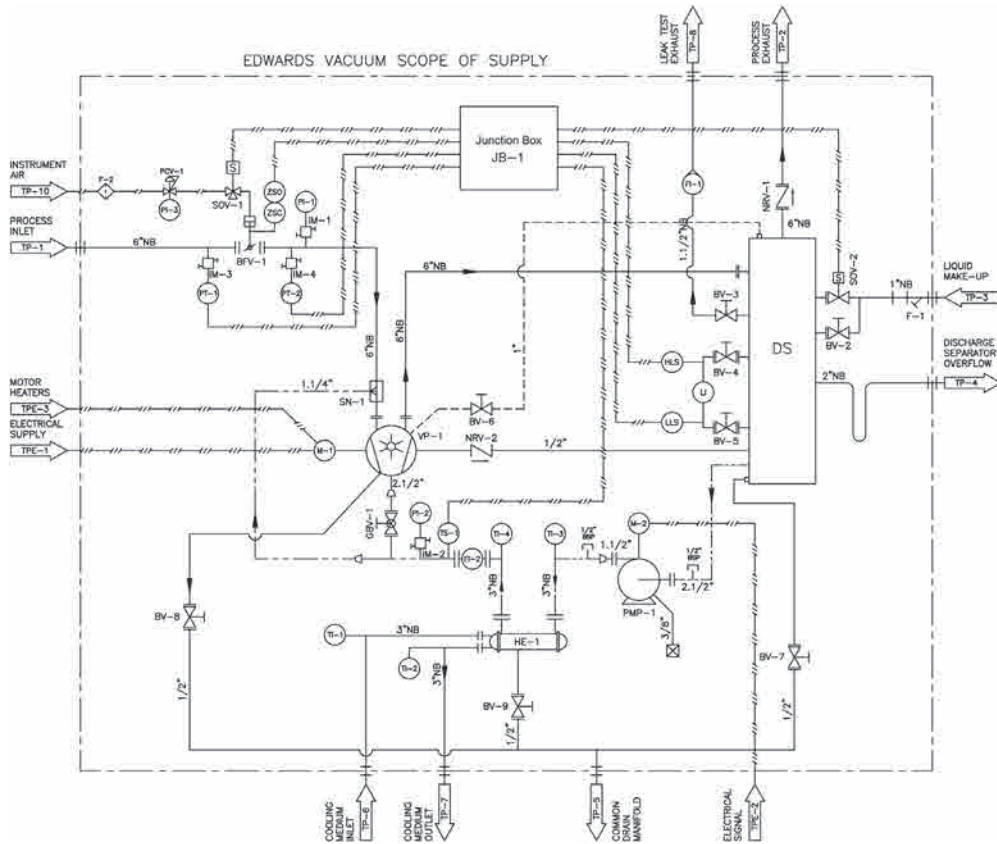

Features & Benefits

- Two stage liquid ring pump - for optimum performance supporting the steam condenser outlet pressure
- Automatic inlet isolating valve controlled by differential switch - for effective transition from hogging to holding
- Inlet water spray nozzle - to reduce condensable load at pump suction
- Interstage cavitation control valve - to reduce cavitation when operating at pressures close to the seal water vapour pressure
- Carbon steel discharge separator complete with level control and discharge air flow measuring capability
- Shell and tube heat exchanger with large diameter stainless steel tubes - maintaining efficiency by minimising fouling and corrosion
- Seal water recirculation pump - to optimise seal water flow rate
- Welded carbon steel piping - to minimise leaks
- Electric motor standard or specific to customer requirements
- On skid junction box - single point electrical connection.

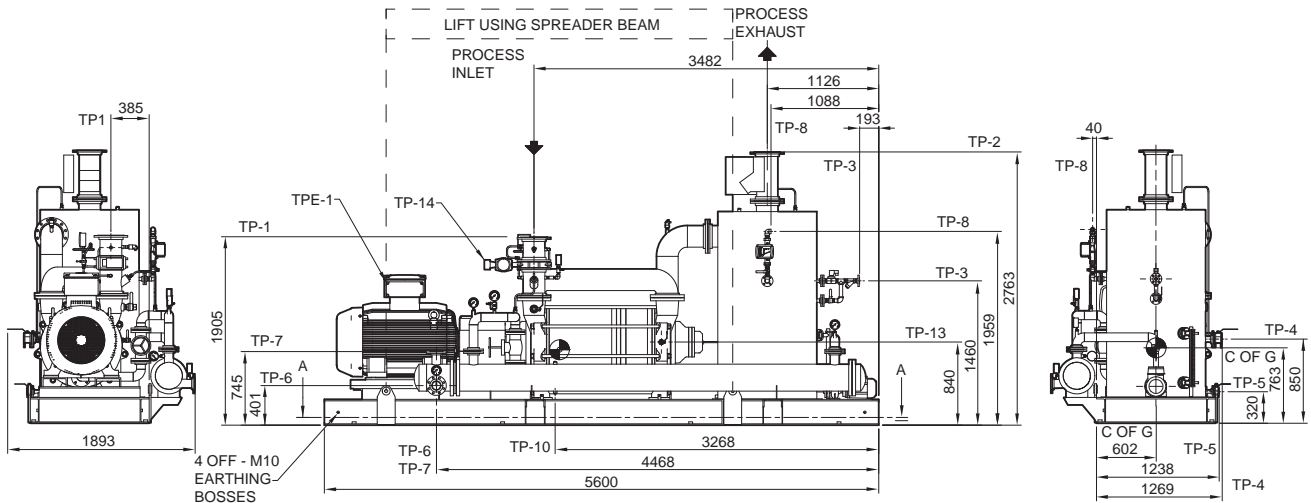

Model	Pump	SCFM	HP	kW	A	B	C
CEP750-2	SHR2400	5 - 7.5	40	22	2350	1000	1500
CEP1000-2	SHR2750	7.5 - 12.5	75	45	3750	1350	2000
CEP1500-2	SHR2950	10 - 20	100	55	3750	1350	2000
CEP2000-2	SHR21200	15 - 25	125	75	4500	1500	2500
CEP3000-2	SHR21850	20 - 30	175	110	4500	1500	2500
CEP6000-2	SHR22500	25 - 40	225	132	5500	1700	3000

Waterbox Priming

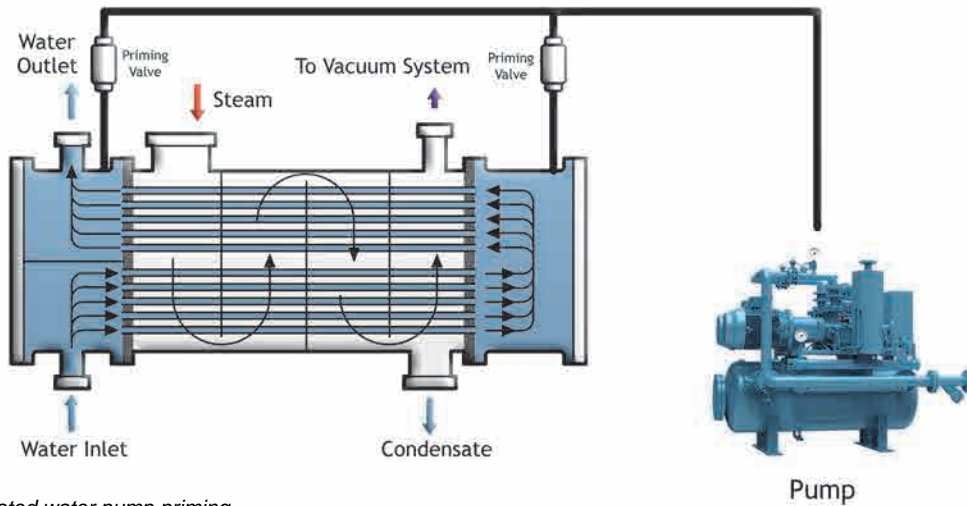

Waterbox and circulated water pump priming

The ability to handle wet gases without detrimental effect makes liquid ring vacuum pumps ideal for this priming application. The pumps are used initially to carry out priming of the main condenser water boxes and CW pump; once this is complete they are used to maintain vacuum in the water box at the required level.

The removal of air from the condenser waterbox prevents accumulation of air in the upper parts of the cooling tube bundle, thereby preventing air locks and maintaining the effective cooling surface of the condenser, ensuring maximum cooling efficiency.

The Edwards priming system is a modular design comprising three component parts: vacuum pumps, vacuum receiver and priming valve and accessories, which are supplied as required to meet customer specifications.

The vacuum pump system comprises a single stage liquid ring pump complete with a total seal water recirculation system, sized to meet the process duty requirements. If duty and standby pumpsets are called for, then two systems are provided, giving true standby capability including the seal water recirculation system.

The vacuum receiver vessel is complete with a pressure transmitter to control the pump operation and includes an automatic drain tank arrangement to remove any water carry over from the system, therefore avoiding corrosion. If required, a priming valve and associated accessories can be supplied for each condenser vacuum connection: the priming valve helps to prevent cycling of the vacuum system and minimises carryover of cooling water.

Additional connections can be made to the vacuum receiver to enable main cooling water pumps to be primed before operation.



Exhaust Gas Treatment Applications

The boiler exhaust gas is conditioned by an electrostatic precipitator which extracts the fly ash, before entering an absorber/scrubber where Sulphur Dioxide is absorbed by a limestone slurry forming gypsum as a by product.

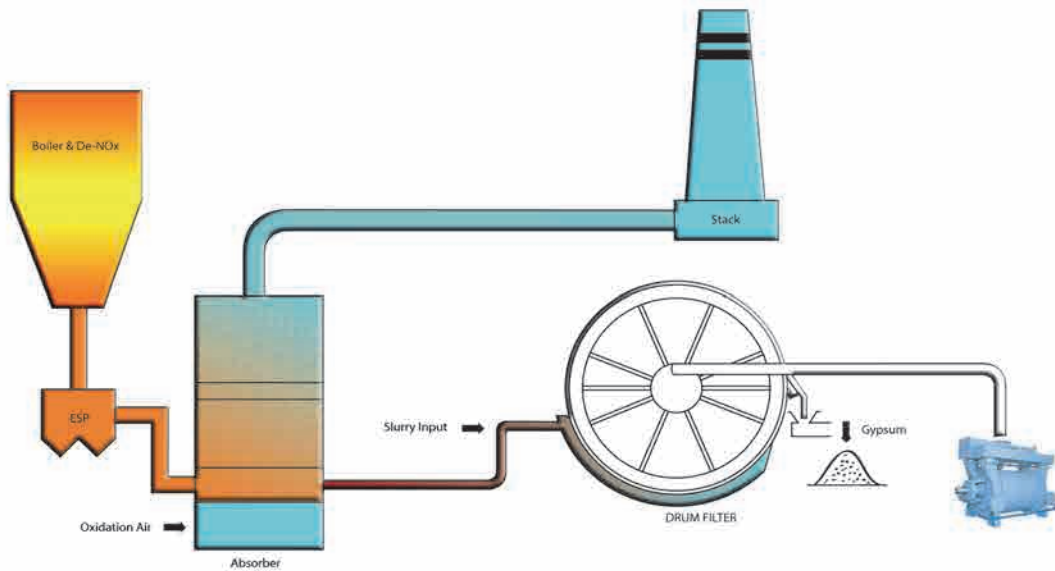

Flue Gas Desulphurisation

Flue gas desulphurisation systems are a common feature on modern coal fired power plants, a by product of the process is gypsum which must be dewatered to enable it to be sold commercially. This is usually carried out using a rotary drum filter, which utilises a large single stage liquid ring pump to remove the water by sucking air through the slurry, leaving behind the dewatered gypsum. The vacuum pump is selected depending upon the surface area of the filter.

The table below shows the appropriate pump model for a selection of nominal capacities.

Nominal Capacity m^3h^{-1}	Pump Size	Motor Size kW	Motor Size HP	Drive Type
2500	LR1A2500	55	75	V-belt
5000	LR1A5000	110	150	V-belt
6500	LR1A6500	160	220	V-belt
10000	LR1A10000	200	270	V-belt
13000	LR1A13000	330	450	V-belt
19000	LR1B18000	355	475	Gearbox
30000	LR1B30000	710	950	Gearbox
37000	LR1B38000	800	1000	Gearbox

Fly Ash Handling

Once the fly ash has been separated in the ESP it is collected in a hopper, from the hopper the ash is transported by a vacuum conveying system to a collection area for disposal or conversion into building products. The vacuum conveying duty is ideally suited to single stage liquid ring pumps which can handle any carryover of the abrasive ash.

EHR2190 Liquid Ring Pump



Within Edwards' full range of liquid ring vacuum pumps, the EHR series offers a two-stage construction for peak performance at low suction pressures. Liquid ring pumps are ideal for pumping either dry or wet gases, with a high tolerance to liquid carry over.

Pumps can be supplied as bare shaft or as part of a package complete with drive motor, discharge separator, heat exchanger and other accessories for recirculation of the seal liquid. In addition, all Edwards liquid ring pumps are available as part of ATEX category 1 or category 2 pump systems.

This model is the EHR2190 Cast Iron material variant.

Features & Benefits

- Two stage design - peak efficiency at high vacuum
- Operates across entire vacuum range
- Mechanical shaft seals
- Choice of construction materials
- Rugged, robust construction

Dimensions

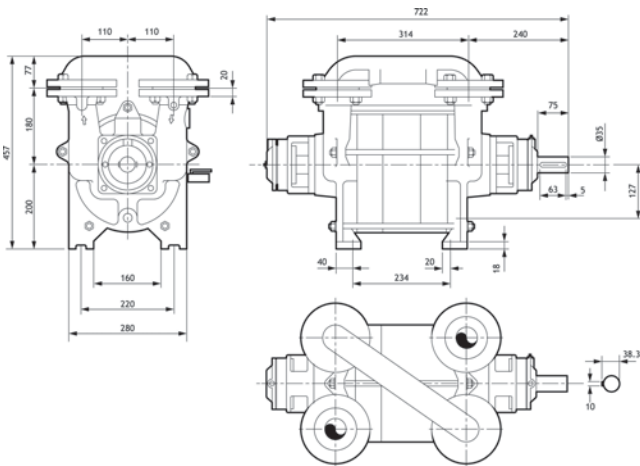

Applications

- The EHR2190 is ideal for vacuum distillation and evaporator applications in the chemical, pharmaceutical and biofuels industry, and is also suited to condenser air extraction in the power industry.

Performance Curves

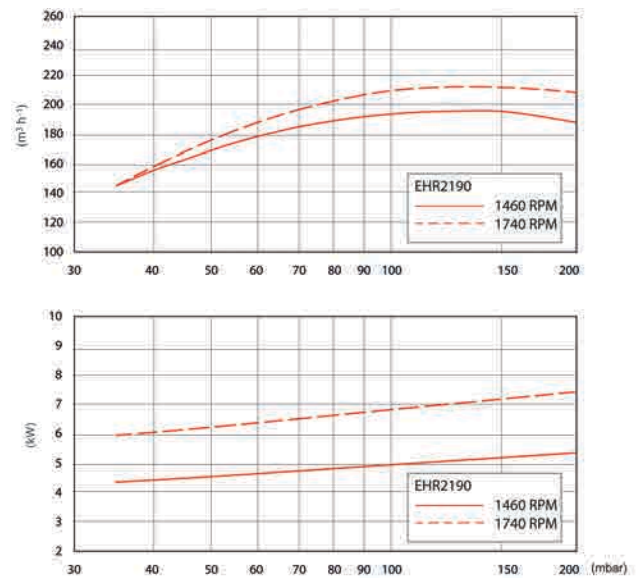

Technical Data

	50 Hz	60 Hz
Nominal capacity	190 m ³ h ⁻¹	215 m ³ h ⁻¹
Suction pressure	30 mbara	30 mbara
Nominal speed	1470 rpm	1740 rpm
Nominal motor power	5.5 kW	7.5 kW
Weight	90 kg	90 kg

Materials of construction

Casing	Cast Iron
Body	Cast Iron
Impeller	SG Iron
Shaft	420S37
Seals	Mechanical

Ordering Information

Product Description	Order No.
EHR2190 Cast Iron	A80000000
EHR2190 Stainless Steel	A80001000
EHR2190 Stainless Steel Fitted	A80005000

EHR2390 Liquid Ring Pump

Within Edwards' full range of liquid ring vacuum pumps, the EHR series offers a two-stage construction for peak performance at low suction pressures. Liquid ring pumps are ideal for pumping either dry or wet gases, with a high tolerance to liquid carry over.

Pumps can be supplied as bare shaft or as part of a package complete with drive motor, discharge separator, heat exchanger and other accessories for recirculation of the seal liquid. In addition, all Edwards liquid ring pumps are available as part of ATEX category 1 or category 2 pump systems.

This model is the EHR2390 Cast Iron material variant.



Features & Benefits

- Two stage design - peak efficiency at high vacuum
- Operates across entire vacuum range
- Mechanical shaft seals
- Choice of construction materials
- Rugged, robust construction

Dimensions

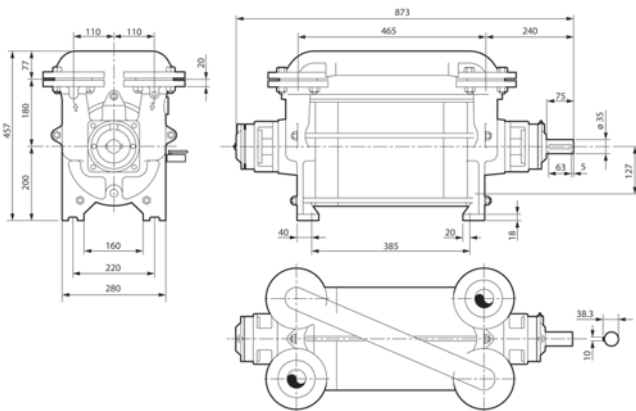

Applications

- The EHR2390 is ideal for vacuum distillation and evaporator applications in the chemical, pharmaceutical and bio-fuels industry, and is also suited to condenser air extraction in the power industry.

Performance Curves

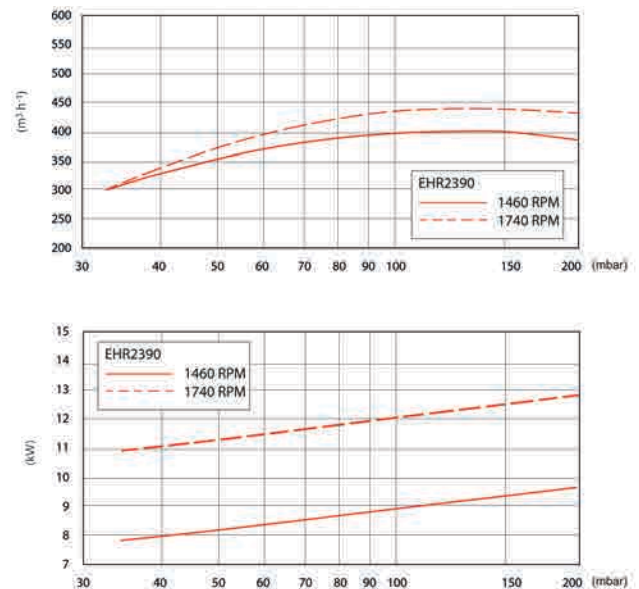

Technical Data

	50 Hz	60 Hz
Nominal capacity	390 m ³ h ⁻¹	440 m ³ h ⁻¹
Suction pressure	30 mbara	30 mbara
Nominal speed	1470 rpm	1740 rpm
Nominal motor power	11 kW	15 kW
Weight	160 kg	160kg

Materials of construction

Casing	Cast Iron
Body	Cast Iron
Impeller	SG Iron
Shaft	420S37
Seals	Mechanical

Ordering Information

Product Description	Order No.
EHR2390 Cast Iron	A80020000
EHR2390 Stainless Steel	A80021000
EHR2390 Stainless Steel Fitted	A80025000

SHR2400 Liquid Ring Pump



Within Edwards' full range of liquid ring vacuum pumps, the SHR series offers a two-stage construction for peak performance at low suction pressures. Liquid ring pumps are ideal for pumping either dry or wet gases, with a high tolerance to liquid carry over.

Pumps can be supplied as bare shaft or as part of a package complete with drive motor, discharge separator, heat exchanger and other accessories for recirculation of the seal liquid. In addition, all Edwards liquid ring pumps are available as part of ATEX category 1 or category 2 pump systems.

This model is the SHR2400 Cast Iron material variant.

Features & Benefits

- Two stage design - peak efficiency at high vacuum
- Operates across entire vacuum range
- Mechanical shaft seals
- Choice of construction materials
- Rugged, robust construction

Dimensions

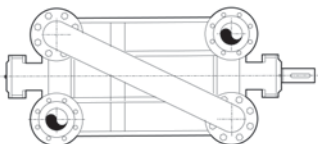
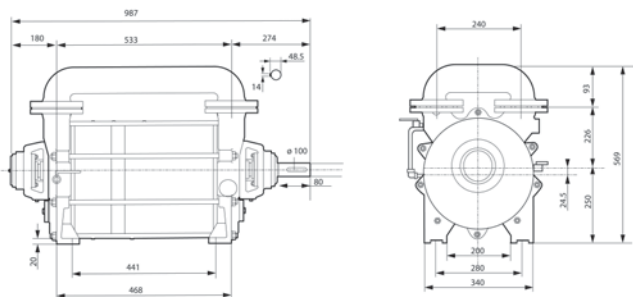

Applications

- The SHR2400 is ideal for vacuum distillation and evaporator applications in the chemical, pharmaceutical and biofuels industry, and is also suited to condenser air extraction in the power industry.

Performance Curves

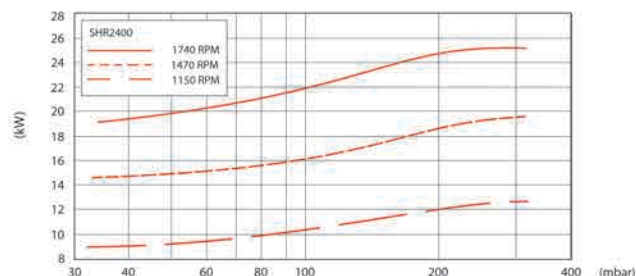
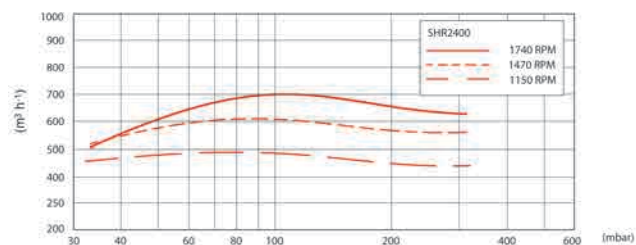

Technical Data

	50 Hz	60 Hz
Nominal capacity	610 m ³ h ⁻¹	700 m ³ h ⁻¹
Suction pressure	30 mbara	30 mbara
Nominal speed	1470 rpm	1740 rpm
Nominal motor power	22 kW	30 kW
Weight	222 kg	222 kg

Materials of construction

Casing	Cast Iron
Body	Cast Iron
Impeller	SG Iron
Shaft	420S37
Seals	Mechanical

Ordering Information

Product Description	Order No.
SHR2400 Cast Iron	A80060000
SHR2400 Stainless Steel	A80061000
SHR2400 Stainless Steel Fitted	A80065000

SHR2750 Liquid Ring Pump

Within Edwards' full range of liquid ring vacuum pumps, the SHR series offers a two-stage construction for peak performance at low suction pressures. Liquid ring pumps are ideal for pumping either dry or wet gases, with a high tolerance to liquid carry over.

Pumps can be supplied as bareshaft or as part of a package complete with drive motor, discharge separator, heat exchanger and other accessories for recirculation of the seal liquid. In addition, all Edwards liquid ring pumps are available as part of ATEX category 1 or category 2 pump systems.

This model is the SHR2400 Stainless Steel Fitted material variant.



Features & Benefits

- Two stage design - peak efficiency at high vacuum
- Operates across entire vacuum range
- Mechanical shaft seals
- Choice of construction materials
- Rugged, robust construction

Dimensions

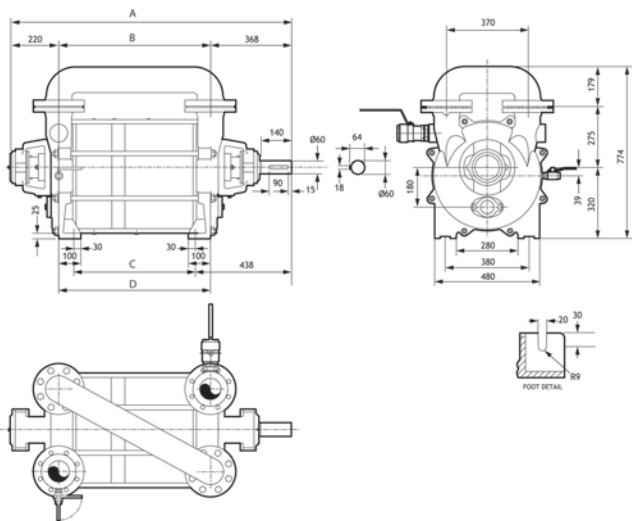

	A	B	C	D
mm	1279	691	551	691
Inch	50.35	27.20	21.69	27.20

Applications

- The SHR2750 is ideal for vacuum distillation and evaporator applications in the chemical, pharmaceutical and biofuels industry, and is also suited to condenser air extraction in the power industry.

Performance Curves

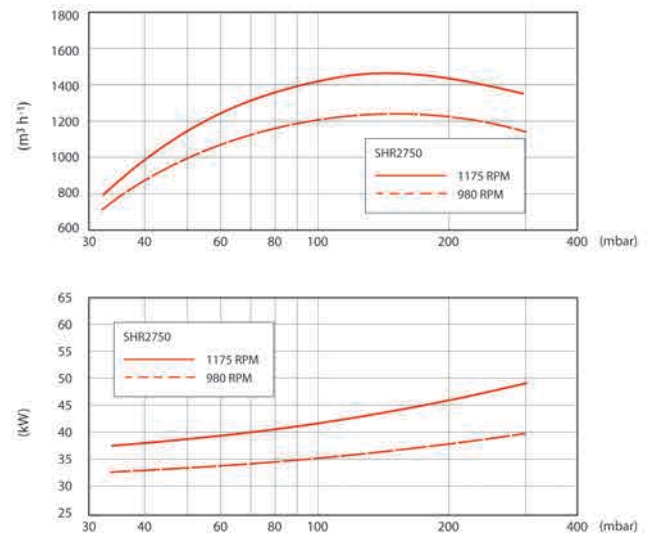

Technical Data

	50 Hz	60 Hz
Nominal capacity	1230 m ³ h ⁻¹	1440 m ³ h ⁻¹
Suction pressure	30 mbara	30 mbara
Nominal speed	980 rpm	1175 rpm
Nominal motor power	45 kW	55 kW
Weight	584 kg	584 kg

Materials of construction

Casing	Cast Iron
Body	Cast Iron
Impeller	SG Iron
Shaft	420S37
Seals	Mechanical

Ordering Information

Product Description	Order No.
SHR2750 Cast Iron	A80090000
SHR2750 Stainless Steel	A80091000
SHR2750 Stainless Steel Fitted	A80095000

SHR2950 Liquid Ring Pump



Within Edwards' full range of liquid ring vacuum pumps, the SHR series offers a two-stage construction for peak performance at low suction pressures. Liquid ring pumps are ideal for pumping either dry or wet gases, with a high tolerance to liquid carry over.

Pumps can be supplied as bare shaft or as part of a package complete with drive motor, discharge separator, heat exchanger and other accessories for recirculation of the seal liquid. In addition, all Edwards liquid ring pumps are available as part of ATEX category 1 or category 2 pump systems.

This model is the SHR2950 Cast Iron material variant.

Features & Benefits

- Two stage design - peak efficiency at high vacuum
- Operates across entire vacuum range
- Mechanical shaft seals
- Choice of construction materials
- Rugged, robust construction

Dimensions

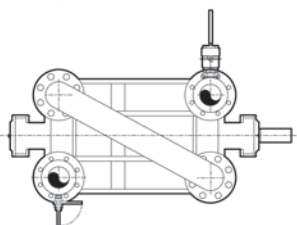
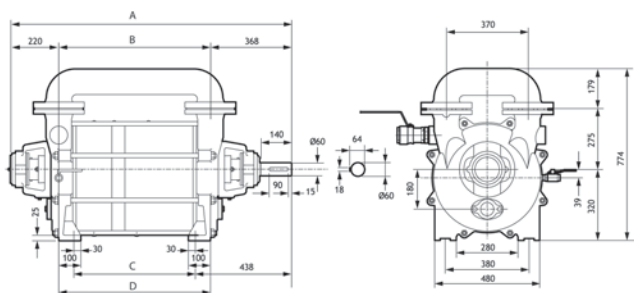

	A	B	C	D
mm	1379	791	651	791
Inch	54.29	31.14	25.94	31.14

Applications

- The SHR2950 is ideal for vacuum distillation and evaporator applications in the chemical, pharmaceutical and biofuels industry, and is also suited to condenser air extraction in the power industry.

Performance Curves

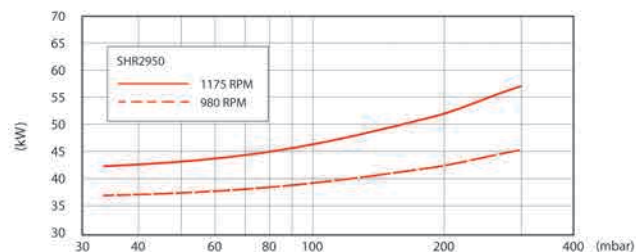
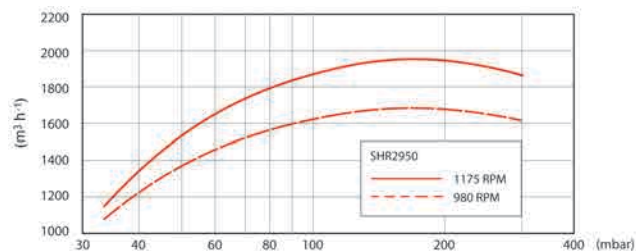

Technical Data

	50 Hz	60 Hz
Nominal capacity	1680 m ³ h ⁻¹	1920 m ³ h ⁻¹
Suction pressure	30 mbara	30 mbara
Nominal speed	980 rpm	1175 rpm
Nominal motor power	55 kW	75 kW
Weight	760 kg	760 kg

Materials of construction

Casing	Cast Iron
Body	Cast Iron
Impeller	SG Iron
Shaft	420S37
Seals	Mechanical

Ordering Information

Product Description	Order No.
SHR2950 Cast Iron	A80100000
SHR2950 Stainless Steel	A80101000
SHR2950 Stainless Steel Fitted	A80105000

SHR21850 Liquid Ring Pump



Within Edwards' full range of liquid ring vacuum pumps, the SHR series offers a two-stage construction for peak performance at low suction pressures. Liquid ring pumps are ideal for pumping either dry or wet gases, with a high tolerance to liquid carry over.

Pumps can be supplied as bare shaft or as part of a package complete with drive motor, discharge separator, heat exchanger and other accessories for recirculation of the seal liquid. In addition, all Edwards liquid ring pumps are available as part of ATEX category 1 or category 2 pump systems.

This model is the SHR21850 Cast Iron material variant.

Features & Benefits

- Two stage design - peak efficiency at high vacuum
- Operates across entire vacuum range
- Mechanical shaft seals
- Choice of construction materials
- Rugged, robust construction

Dimensions

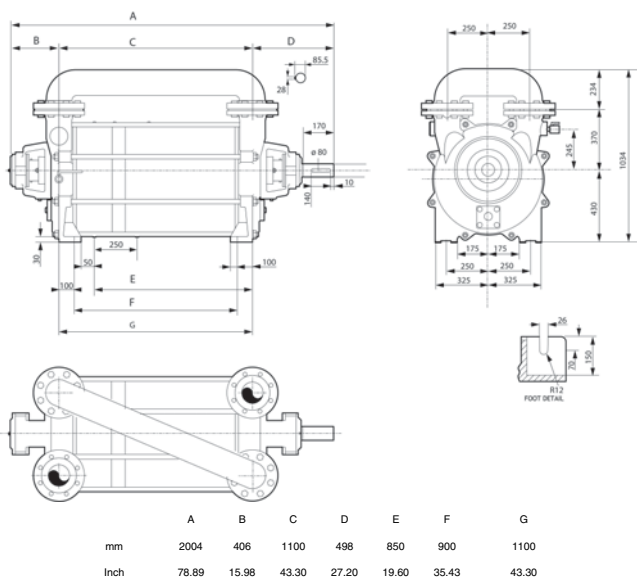

Applications

- The SHR21850 is ideal for vacuum distillation and evaporator applications in the chemical, pharmaceutical and biofuels industry, and is also suited to condenser air extraction in the power industry.

Performance Curves

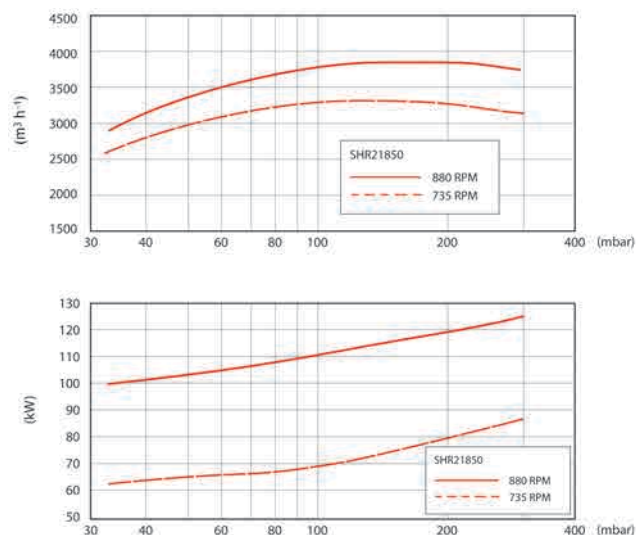

Technical Data

	50 Hz	60 Hz
Nominal capacity	3280 m ³ h ⁻¹	3800 m ³ h ⁻¹
Suction pressure	30 mbara	30 mbara
Nominal speed	735 rpm	880 rpm
Nominal motor power	110 kW	132 kW
Weight	1680 kg	1680 kg
Materials of construction		
Casing	Cast Iron	
Body	Cast Iron	
Impeller	SG Iron	
Shaft	420S37	
Seals	Mechanical	

Ordering Information

Product Description	Order No.
SHR21850 Cast Iron	A80150000
SHR21850 Stainless Steel	A80151000
SHR21850 Stainless Steel Fitted	A80155000

SHR22500 Liquid Ring Pump

Within Edwards' full range of liquid ring vacuum pumps, the SHR series offers a two-stage construction for peak performance at low suction pressures. Liquid ring pumps are ideal for pumping either dry or wet gases, with a high tolerance to liquid carry over.

Pumps can be supplied as bareshaft or as part of a package complete with drive motor, discharge separator, heat exchanger and other accessories for recirculation of the seal liquid. In addition, all Edwards liquid ring pumps are available as part of ATEX category 1 or category 2 pump systems.

This model is the SHR22500 Cast Iron material variant.



Features & Benefits

- Two stage design - peak efficiency at high vacuum
- Operates across entire vacuum range
- Mechanical shaft seals
- Choice of construction materials
- Rugged, robust construction

Dimensions

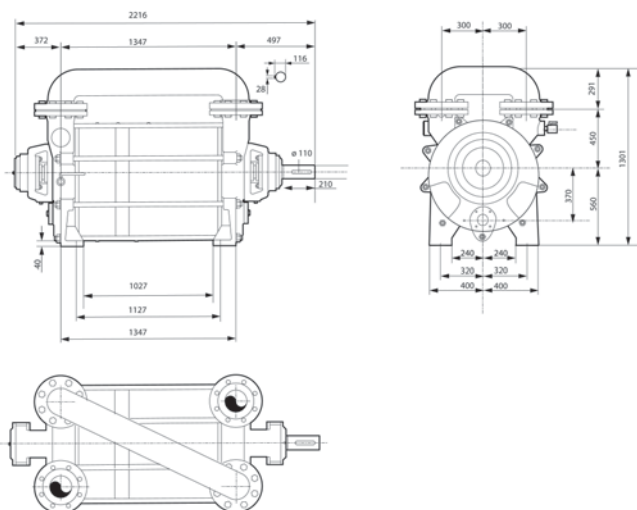

Applications

- The SHR22500 is ideal for vacuum distillation and evaporator applications in the chemical, pharmaceutical and biofuels industry, and is also suited to condenser air extraction in the power industry.

Performance Curves

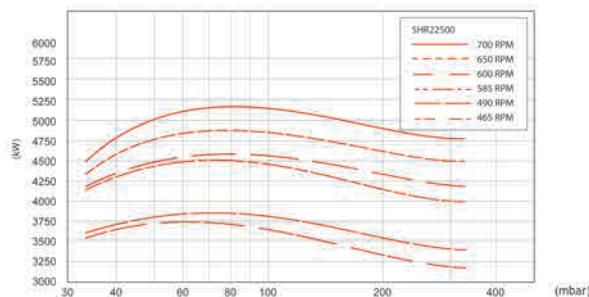
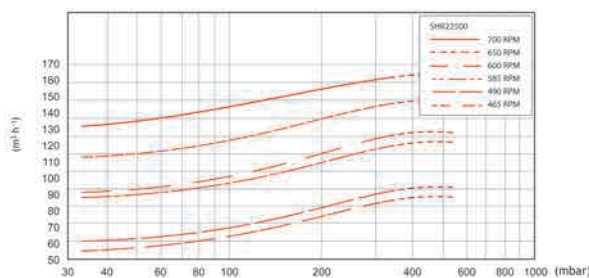

Technical Data

	50 Hz	60 Hz
Nominal capacity	4510 m ³ h ⁻¹	4900 m ³ h ⁻¹
Suction pressure	30 mbara	30 mbara
Nominal speed	585 rpm	650 rpm
Nominal motor power	132 kW	150 kW
Weight	2635 kg	2635 kg

Materials of construction

Casing	Cast Iron
Body	Cast Iron
Impeller	SG Iron
Shaft	420S37
Seals	Mechanical

Ordering Information

Product Description	Order No.
SHR22500 Cast Iron	A80170000
SHR22500 Stainless Steel	A80171000
SHR22500 Stainless Steel Fitted	A80175000

LR1A200 Liquid Ring Pump



Edwards offers a full range of liquid ring pumps. The LR1A200 provides a single-stage design and curved blade impellor with reinforcing rings for improved ruggedness, reducing noise and vibration.

All of our liquid ring pumps handle wet or dry gases, with high tolerance to liquid carry over. The LR1A Series has an enhanced bearing design enabling reduced internal clearances for improved efficiency. Pumps are available in cast iron and 316 stainless steel construction as standard with other materials and corrosion resistant coatings available.

Features & Benefits

- Optional central partition enabling dual vacuum duty operation
- Variable area discharge port for optimum performance at all inlet pressures
- Packed gland, single and double mechanical seal options
- Split packing gland design to facilitate repacking
- Internal and external seal flushing options

Dimensions

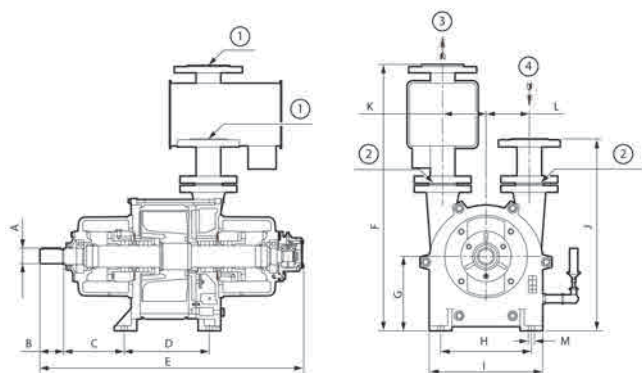

A (keyway)	B	C	D	E	F	G
mm	38	58	146	206	639	645
Inch	1.50	2.28	5.75	8.11	25.16	25.39
H	I	J	K	L	M	
mm	220	275	464	105	105	4 holes Ø 15
Inch	8.66	10.83	18.27	4.13	4.13	0.59

1. DN65 / PN10 2. DN50 / PN10 3. Outlet 4. Inlet
*Flanges available in both DIN and ANSI standards

Applications

- The LR1A200 is ideal for filtration, vacuum forming, general industrial and chemical and petrochemical applications.

Performance Curves

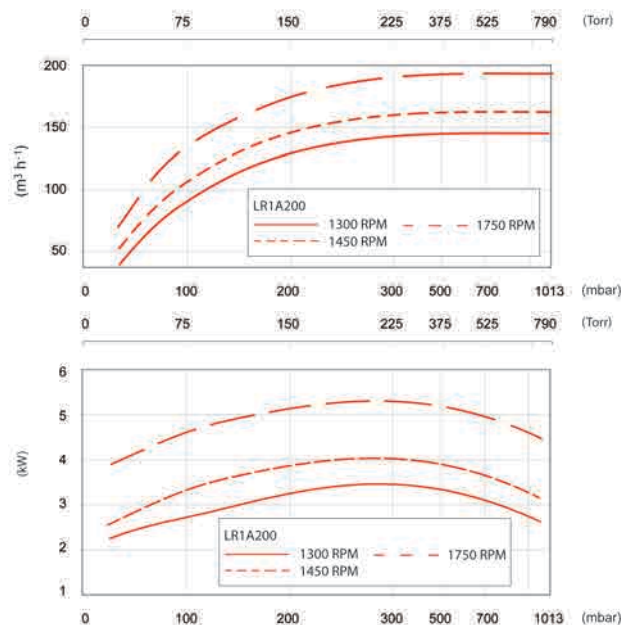

Technical Data

	50 Hz	60 Hz
Nominal capacity (saturated)	170 m ³ h ⁻¹	200 m ³ h ⁻¹
	100 CFM	120 CFM
Suction pressure	33 mbar	33 mbar
	25 Torr	25 Torr
Nominal speed	1450 rpm	1750 rpm
Nominal motor power	5.5 kW	7.5 kW
	7.5 HP	10 HP

Ordering Information

Product Description	Order No.
LR1A200 Liquid Ring Pump	LR1A200

LR1A300 Liquid Ring Pump

Edwards offers a full range of liquid ring pumps. The LR1A300 provides a single-stage design and curved blade impellor with reinforcing rings for improved ruggedness, reducing noise and vibration.

All of our liquid ring pumps handle wet or dry gases, with high tolerance to liquid carry over. The LR1A Series has an enhanced bearing design enabling reduced internal clearances for improved efficiency. Pumps are available in cast iron and 316 stainless steel construction as standard with other materials and corrosion resistant coatings available.



Features & Benefits

- Optional central partition enabling dual vacuum duty operation
- Variable area discharge port for optimum performance at all inlet pressures
- Packed gland, single and double mechanical seal options
- Split packing gland design to facilitate repacking
- Internal and external seal flushing options

Dimensions

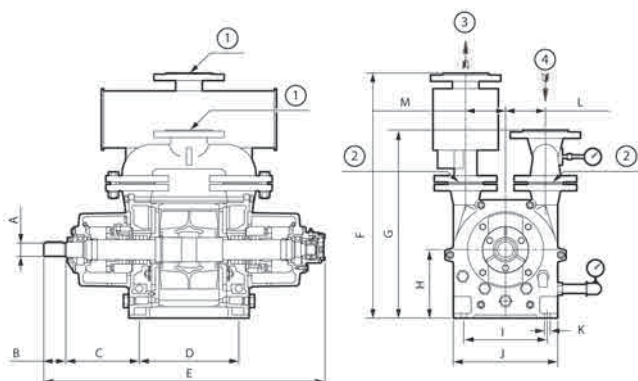

	A (keyway)	B	C	D	E	F	G
mm	38	58	193	262	740	645	495
Inch	1.50	2.28	7.60	10.31	29.13	25.39	19.49
		H	I	J	L	M	K
mm		180	220	275	105	105	4 holes Ø 15
Inch		7.09	8.66	10.83	4.13	4.13	0.59

1. DN65 / PN10 2. DN50 / PN10 3. Outlet 4. Inlet
*Flanges available in both DIN and ANSI standards

Applications

- The LR1A300 is ideal for filtration, vacuum forming, general industrial and chemical and petrochemical applications.

Performance Curves

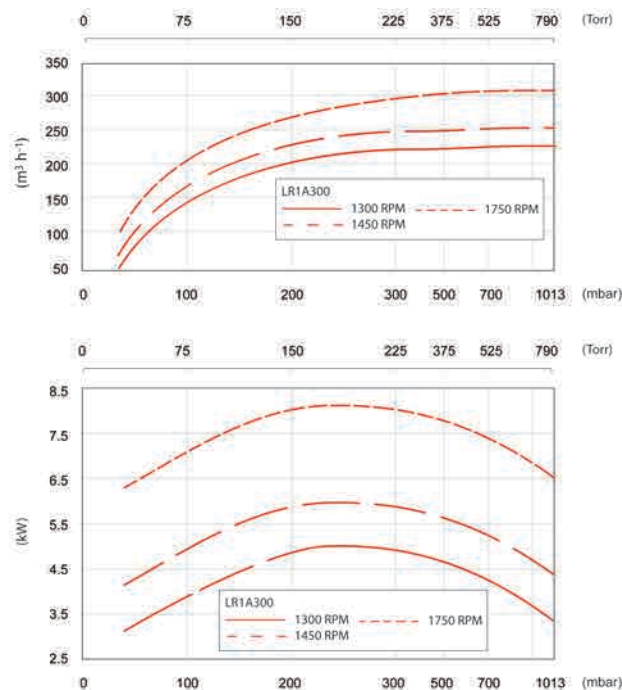

Technical Data

	50 Hz	60 Hz
Nominal capacity (saturated)	260 m ³ h ⁻¹ 150 CFM	320 m ³ h ⁻¹ 180 CFM
Suction pressure	33 mbar 25 Torr	33 mbar 25 Torr
Nominal speed	1450 rpm	1750 rpm
Nominal motor power	7.5 kW 10 HP	11 kW 15 HP

Ordering Information

Product Description	Order No.
LR1A300 Liquid Ring Pump	LR1A300

LR1A400 Liquid Ring Pump



Edwards offers a full range of liquid ring pumps. The LR1A400 provides a single-stage design and curved blade impellor with reinforcing rings for improved ruggedness, reducing noise and vibration.

All of our liquid ring pumps handle wet or dry gases, with high tolerance to liquid carry over. The LR1A Series has an enhanced bearing design enabling reduced internal clearances for improved efficiency. Pumps are available in cast iron and 316 stainless steel construction as standard with other materials and corrosion resistant coatings available.

Features & Benefits

- Optional central partition enabling dual vacuum duty operation
- Variable area discharge port for optimum performance at all inlet pressures
- Packed gland, single and double mechanical seal options
- Split packing gland design to facilitate repacking
- Internal and external seal flushing options

Dimensions

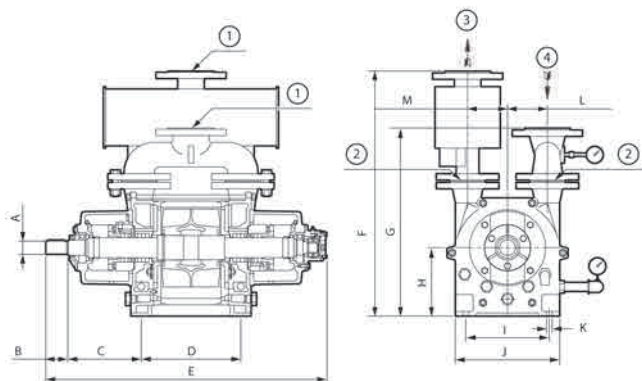

	A (keyway)	B	C	D	E	F	G
mm	38	58	193	316	795	645	495
Inch	1.50	2.28	7.60	12.44	31.30	25.39	19.49
	H	I	J	L	M	K	
mm	180	220	275	105	105	4 holes Ø 15	
Inch	7.09	8.66	10.83	4.13	4.13	0.59	

1, DN65 / PN10 2, DN50 / PN10 3, Outlet 4, Inlet
*Flanges available in both DIN and ANSI standards

Applications

- The LR1A400 is ideal for condenser evacuation, pulp and paper, filtration, vacuum forming and chemical and petrochemical applications.

Performance Curves

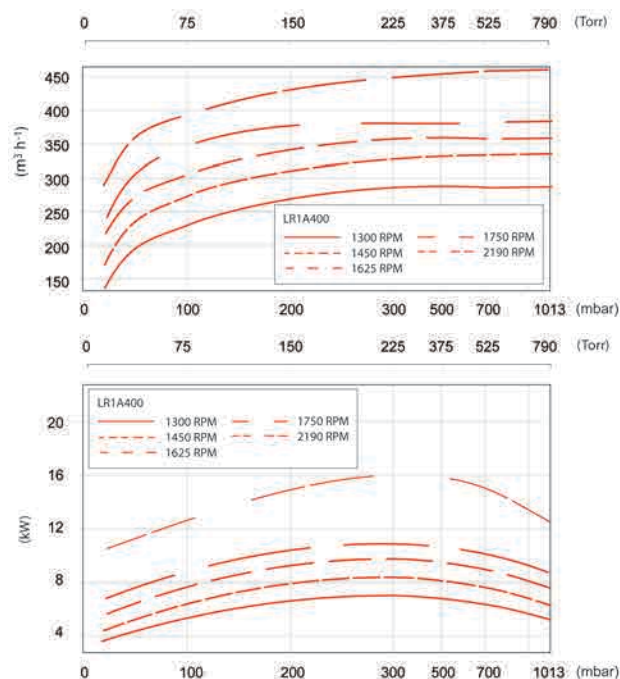

Technical Data

	50 Hz	60 Hz
Nominal capacity (saturated)	350 m ³ h ⁻¹ 205 CFM	420 m ³ h ⁻¹ 250 CFM
Suction pressure	33 mbar 25 Torr	33 mbar 25 Torr
Nominal speed	1450 rpm	1750 rpm
Nominal motor power	11 kW 15 HP	15 kW 20HP

Ordering Information

Product Description	Order No.
LR1A400 Liquid Ring Pump	LR1A400

LR1A500 Liquid Ring Pump

Edwards offers a full range of liquid ring pumps. The LR1A500 provides a single-stage design and curved blade impellor with reinforcing rings for improved ruggedness, reducing noise and vibration.

All of our liquid ring pumps handle wet or dry gases, with high tolerance to liquid carry over. The LR1A Series has an enhanced bearing design enabling reduced internal clearances for improved efficiency. Pumps are available in cast iron and 316 stainless steel construction as standard with other materials and corrosion resistant coatings available.



Features & Benefits

- Optional central partition enabling dual vacuum duty operation
- Variable area discharge port for optimum performance at all inlet pressures
- Packed gland, single and double mechanical seal options
- Split packing gland design to facilitate repacking
- Internal and external seal flushing options

Dimensions

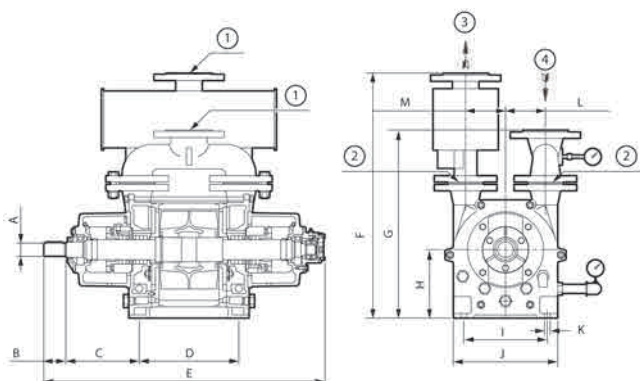

	A (keyway)	B	C	D	E	F	G
mm	38	58	193	316	795	645	495
Inch	1.50	2.28	7.60	12.44	31.30	25.39	19.49
	H	I	J	L	M	K	
mm	180	220	275	105	105	4 holes Ø 15	
Inch	7.09	8.66	10.83	4.13	4.13	0.59	

1. DN65 / PN10 2. DN50 / PN10 3. Outlet 4. Inlet
*Flanges available in both DIN and ANSI standards

Applications

- The LR1A500 is ideal for condenser evacuation, pulp and paper, filtration, vacuum forming, general industrial and chemical and petrochemical applications.

Performance Curves

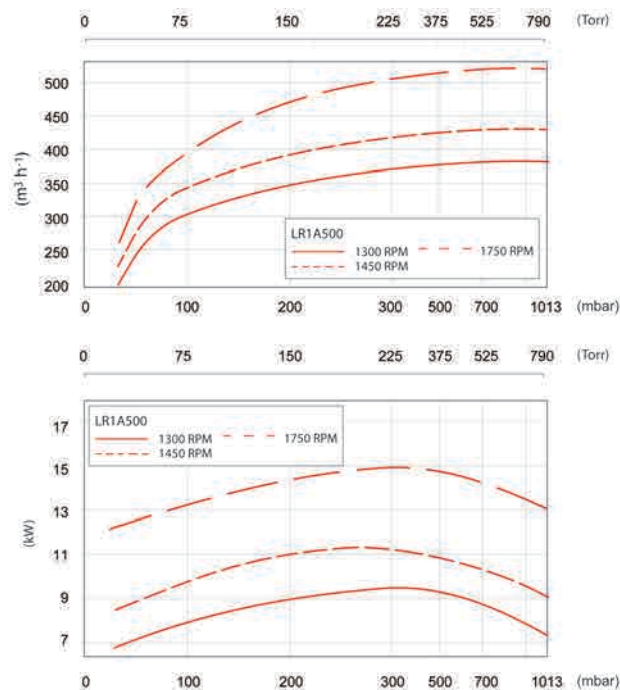

Technical Data

	50 Hz	60 Hz
Nominal capacity (saturated)	430 m ³ h ⁻¹ 250 CFM	530 m ³ h ⁻¹ 300 CFM
Suction pressure	33 mbar 25 Torr	33 mbar 25 Torr
Nominal speed	1450 rpm	1750 rpm
Nominal motor power	15 kW 20 HP	18.5 kW 25 HP

Ordering Information

Product Description	Order No.
LR1A500 Liquid Ring Pump	LR1A500

LR1A700 Liquid Ring Pump



Edwards offers a full range of liquid ring pumps. The LR1A700 provides a single-stage design and curved blade impellor with reinforcing rings for improved ruggedness, reducing noise and vibration.

All of our liquid ring pumps handle wet or dry gases, with high tolerance to liquid carry over. The LR1A Series has an enhanced bearing design enabling reduced internal clearances for improved efficiency. Pumps are available in cast iron and 316 stainless steel construction as standard with other materials and corrosion resistant coatings available.

Features & Benefits

- Optional central partition enabling dual vacuum duty operation
- Variable area discharge port for optimum performance at all inlet pressures
- Packed gland, single and double mechanical seal options
- Split packing gland design to facilitate repacking
- Internal and external seal flushing options

Dimensions

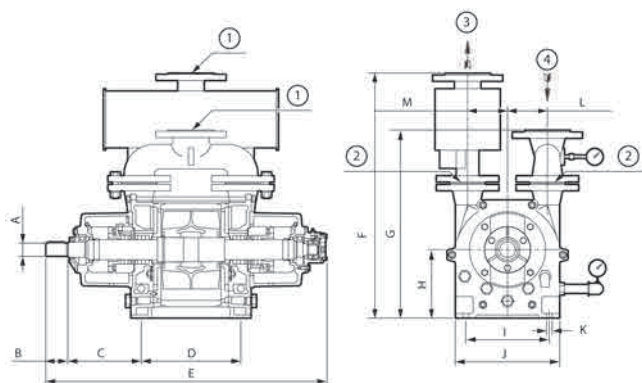

	A (keyway)	B	C	D	E	F	G
mm	38	58	206	380	885	745	600
Inch	1.50	2.28	8.11	14.96	34.85	29.33	23.62
	H	I	J	L	M	K	
mm	225	260	330	105	105	4 holes Ø 19	
Inch	8.86	10.24	12.99	4.13	4.13	0.75	

1. DN65 / PN10 2. DN50 / PN10 3. Outlet 4. Inlet
*Flanges available in both DIN and ANSI standards

Applications

- The LR1A700 is ideal for condenser evacuation, pulp and paper, filtration, vacuum forming and chemical and petrochemical applications.

Performance Curves

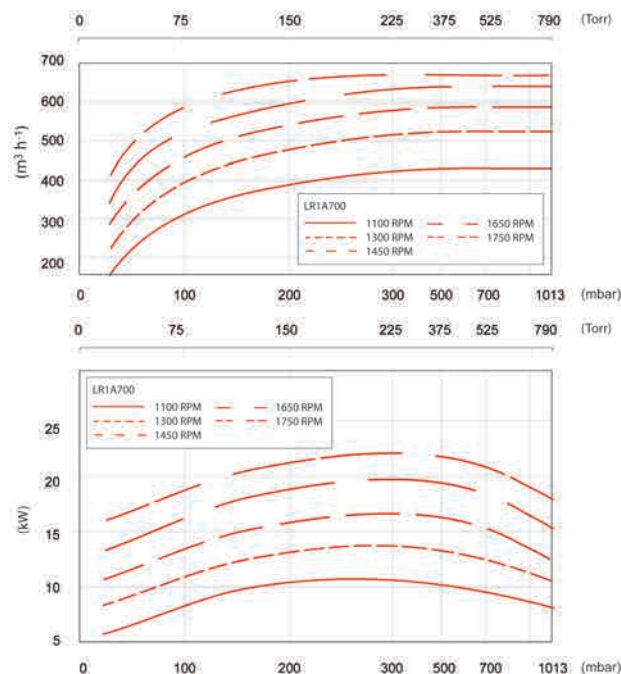

Technical Data

	50 Hz	60 Hz
Nominal capacity (saturated)	600 m ³ h ⁻¹ 350 CFM	690 m ³ h ⁻¹ 420 CFM
Suction pressure	33 mbar 25 Torr	33 mbar 25 Torr
Nominal speed	1450 rpm	1750 rpm
Nominal motor power	18.5 kW 25 HP	22 kW 30 HP

Ordering Information

Product Description	Order No.
LR1A700 Liquid Ring Pump	LR1A700

LR1A800 Liquid Ring Pump

Edwards offers a full range of liquid ring pumps. The LR1A800 provides a single-stage design and curved blade impellor with reinforcing rings for improved ruggedness, reducing noise and vibration.

All of our liquid ring pumps handle wet or dry gases, with high tolerance to liquid carry over. The LR1A Series has an enhanced bearing design enabling reduced internal clearances for improved efficiency. Pumps are available in cast iron and 316 stainless steel construction as standard with other materials and corrosion resistant coatings available.



Features & Benefits

- Optional central partition enabling dual vacuum duty operation
- Variable area discharge port for optimum performance at all inlet pressures
- Packed gland, single and double mechanical seal options
- Split packing gland design to facilitate repacking
- Internal and external seal flushing options

Dimensions

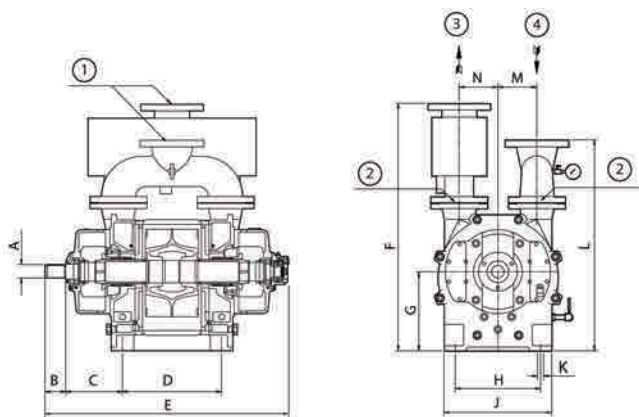

	A (keyway)	B	C	D	E	F	G
mm	54	82	227	395	975	985	315
Inch	2.13	3.23	8.94	15.55	38.39	38.78	12.40
	H	J	L	M	N	K	
mm	340	430	840	155	155	4 holes Ø 24	
Inch	13.39	16.93	33.07	6.10	6.10	0.94	

1. DN125 / PN10 2. DN100 / PN10 3. Outlet 4. Inlet
*Flanges available in both DIN and ANSI standards

Applications

- The LR1A800 is ideal for condenser evacuation, pulp and paper, filtration, vacuum forming and chemical and petrochemical applications.

Performance Curves

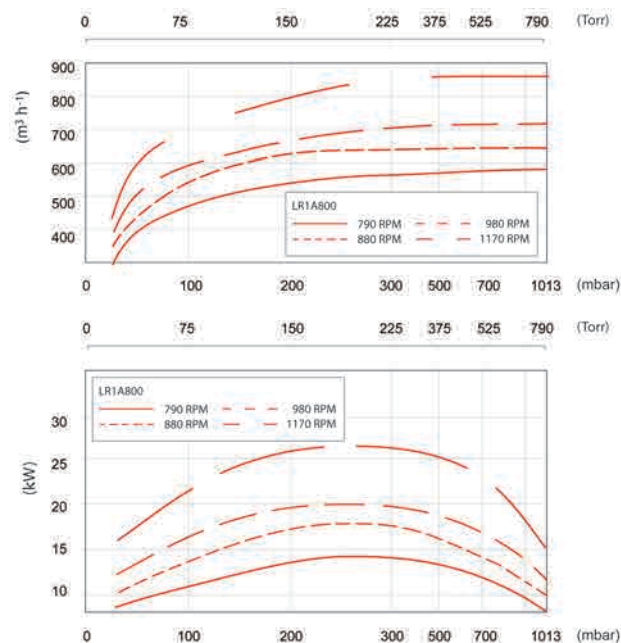

Technical Data

	50 Hz	60 Hz
Nominal capacity (saturated)	780 m ³ h ⁻¹ 460 CFM	900 m ³ h ⁻¹ 550 CFM
Suction pressure	33 mbar 25 Torr	33 mbar 25 Torr
Nominal speed	980 rpm	1170 rpm
Nominal motor power	22 kW 30 HP	30 kW 40 HP

Ordering Information

Product Description	Order No.
LR1A800 Liquid Ring Pump	LR1A800

LR1A1200 Liquid Ring Pump



Edwards offers a full range of liquid ring pumps. The LR1A1200 provides a single-stage design and curved blade impellor with reinforcing rings for improved ruggedness, reducing noise and vibration.

All of our liquid ring pumps handle wet or dry gases, with high tolerance to liquid carry over. The LR1A Series has an enhanced bearing design enabling reduced internal clearances for improved efficiency. Pumps are available in cast iron and 316 stainless steel construction as standard with other materials and corrosion resistant coatings available.

Features & Benefits

- Optional central partition enabling dual vacuum duty operation
- Variable area discharge port for optimum performance at all inlet pressures
- Packed gland, single and double mechanical seal options
- Split packing gland design to facilitate repacking
- Internal and external seal flushing options

Dimensions

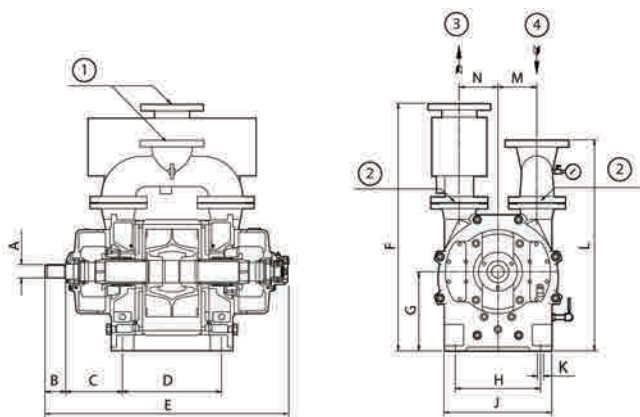

A (keyway)	B	C	D	E	F	G
mm	54	82	227	515	1095	985
Inch	2.13	3.23	8.94	20.28	43.11	38.78
	H	J	L	M	N	K
mm	340	430	840	155	155	4 holes Ø 24
Inch	13.39	16.93	33.07	6.10	6.10	0.94

1. DN125 / PN10 2. DN100 / PN10 3. Outlet 4. Inlet
*Flanges available in both DIN and ANSI standards

Applications

- The LR1A1200 is ideal for condenser evacuation, pulp and paper, filtration, vacuum forming and chemical and petrochemical applications.

Performance Curves

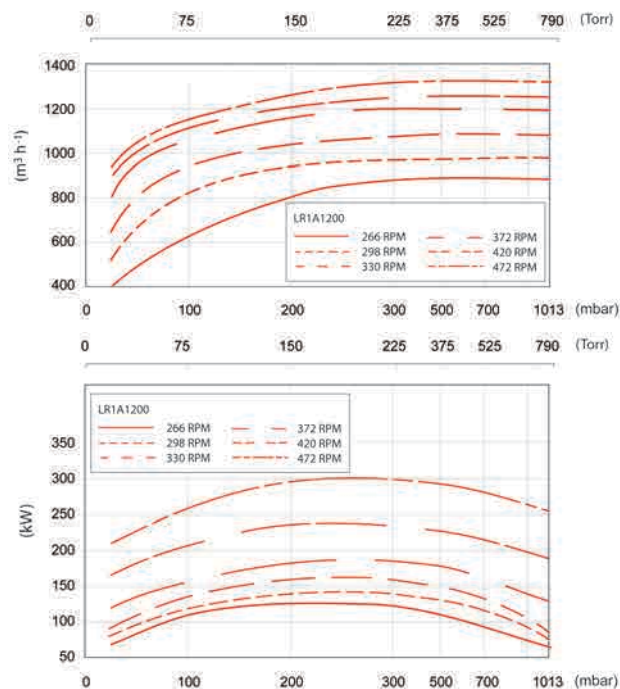

Technical Data

	50 Hz	60 Hz
Nominal capacity (saturated)	1110 m ³ h ⁻¹ 650 CFM	1300 m ³ h ⁻¹ 780 CFM
Suction pressure	33 mbar 25 Torr	33 mbar 25 Torr
Nominal speed	980 rpm	1170 rpm
Nominal motor power	37 kW 50 HP	45 kW 60 HP

Ordering Information

Product Description	Order No.
LR1A1200 Liquid Ring Pump	LR1A1200

LR1A1300 Liquid Ring Pump

Edwards offers a full range of liquid ring pumps. The LR1A1300 provides a single-stage design and curved blade impellor with reinforcing rings for improved ruggedness, reducing noise and vibration.

All of our liquid ring pumps handle wet or dry gases, with high tolerance to liquid carry over. The LR1A Series has an enhanced bearing design enabling reduced internal clearances for improved efficiency. Pumps are available in cast iron and 316 stainless steel construction as standard with other materials and corrosion resistant coatings available.



Features & Benefits

- Optional central partition enabling dual vacuum duty operation
- Variable area discharge port for optimum performance at all inlet pressures
- Packed gland, single and double mechanical seal options
- Split packing gland design to facilitate repacking
- Internal and external seal flushing options

Applications

- The LR1A1300 is ideal for condenser evacuation, pulp and paper, filtration, vacuum forming and chemical and petrochemical applications.

Dimensions

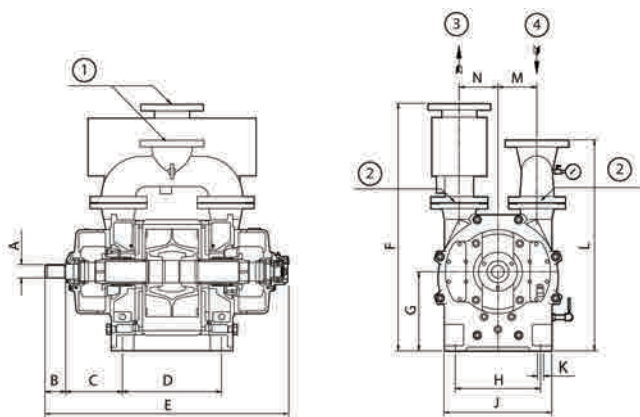

	A (keyway)	B	C	D	E	F	G
mm	54	82	227	551	1131	985	315
Inch	2.13	3.23	8.94	21.70	44.53	38.78	12.40
	H	J	L	M	N	K	
mm	340	430	840	155	155	4 holes Ø 24	
Inch	13.39	16.93	33.07	6.10	6.10	0.94	

1. DN125 / PN10 2. DN100 / PN10 3. Outlet 4. Inlet
*Flanges available in both DIN and ANSI standards

Performance Curves

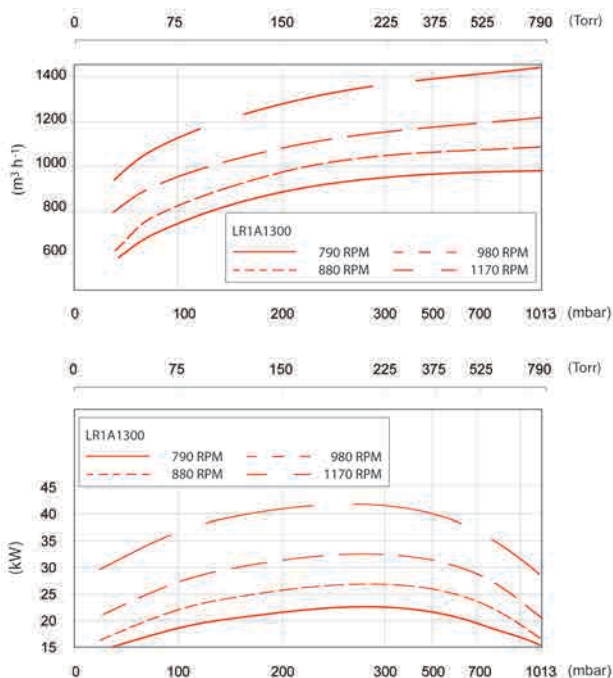

Technical Data

	50 Hz	60 Hz
Nominal capacity (saturated)	1200 m ³ h ⁻¹ 700 CFM	1400 m ³ h ⁻¹ 850 CFM
Suction pressure	33 mbar 25 Torr	33 mbar 25 Torr
Nominal speed	980 rpm	1170 rpm
Nominal motor power	37 kW 50 HP	45 kW 60 HP

Ordering Information

Product Description	Order No.
LR1A1300 Liquid Ring Pump	LR1A1300

LR1A1600 Liquid Ring Pump



Edwards offers a full range of liquid ring pumps. The LR1A1600 provides a single-stage design and curved blade impellor with reinforcing rings for improved ruggedness, reducing noise and vibration.

All of our liquid ring pumps handle wet or dry gases, with high tolerance to liquid carry over. The LR1A Series has an enhanced bearing design enabling reduced internal clearances for improved efficiency. Pumps are available in cast iron and 316 stainless steel construction as standard with other materials and corrosion resistant coatings available.

Features & Benefits

- Optional central partition enabling dual vacuum duty operation
- Variable area discharge port for optimum performance at all inlet pressures
- Packed gland, single and double mechanical seal options
- Split packing gland design to facilitate repacking
- Internal and external seal flushing options

Dimensions

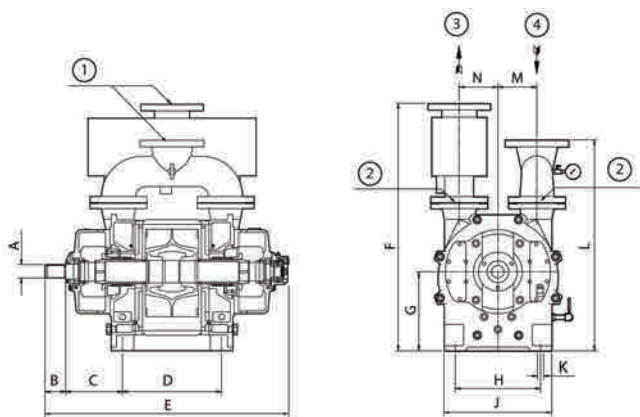

	A (keyway)	B	C	D	E	F	G
mm	74.5	105	263	525	1237	1245	400
Inch	2.93	4.13	10.35	20.67	48.70	49.02	15.74
	H	J	L	M	N	K	
mm	465	570	1030	215	215	4 holes Ø 28	
Inch	18.31	22.44	40.55	8.46	8.46	1.10	

1. DN150 / PN10 2. DN125 / PN10 3. Outlet 4. Inlet
*Flanges available in both DIN and ANSI standards

Applications

- The LR1A1600 is ideal for condenser evacuation, pulp and paper, filtration, vacuum forming and chemical and petrochemical applications.

Performance Curves

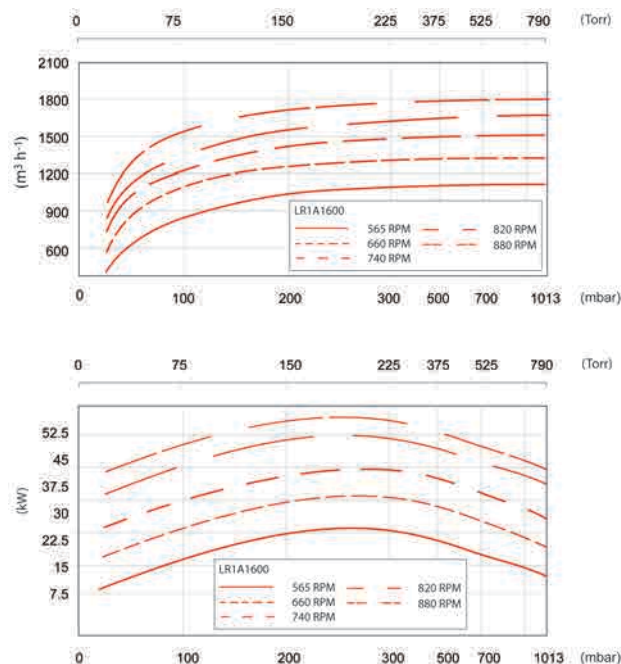

Technical Data

	50 Hz	60 Hz
Nominal capacity (saturated)	1550 m ³ h ⁻¹ 900 CFM	1800 m ³ h ⁻¹ 1100 CFM
Suction pressure	33 mbar 25 Torr	33 mbar 25 Torr
Nominal speed	740 rpm	880 rpm
Nominal motor power	45 kW 60 HP	55 kW 75 HP

Ordering Information

Product Description	Order No.
LR1A1600 Liquid Ring Pump	LR1A1600

LR1A2500 Liquid Ring Pump

Edwards offers a full range of liquid ring pumps. The LR1A2500 provides a single-stage design and curved blade impellor with reinforcing rings for improved ruggedness, reducing noise and vibration.

All of our liquid ring pumps handle wet or dry gases, with high tolerance to liquid carry over. The LR1A Series has an enhanced bearing design enabling reduced internal clearances for improved efficiency. Pumps are available in cast iron and 316 stainless steel construction as standard with other materials and corrosion resistant coatings available.



Features & Benefits

- Optional central partition enabling dual vacuum duty operation
- Variable area discharge port for optimum performance at all inlet pressures
- Packed gland, single and double mechanical seal options
- Split packing gland design to facilitate repacking
- Internal and external seal flushing options

Dimensions

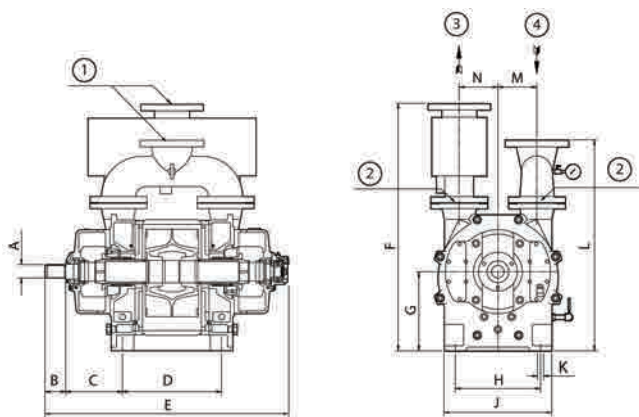

	A (keyway)	B	C	D	E	F	G
mm	74.5	105	263	675	1395	1245	400
Inch	2.93	4.13	10.35	26.57	54.92	49.02	15.74
	H	J	L	M	N	K	
mm	465	570	1030	215	215	4 holes Ø 28	
Inch	18.31	22.44	40.55	8.46	8.46	1.10	

1. DN150 / PN10 2. DN125 / PN10 3. Outlet 4. Inlet
*Flanges available in both DIN and ANSI standards

Applications

- The LR1A2500 is ideal for condenser evacuation, pulp and paper, filtration, vacuum forming and chemical and petrochemical applications.

Performance Curves

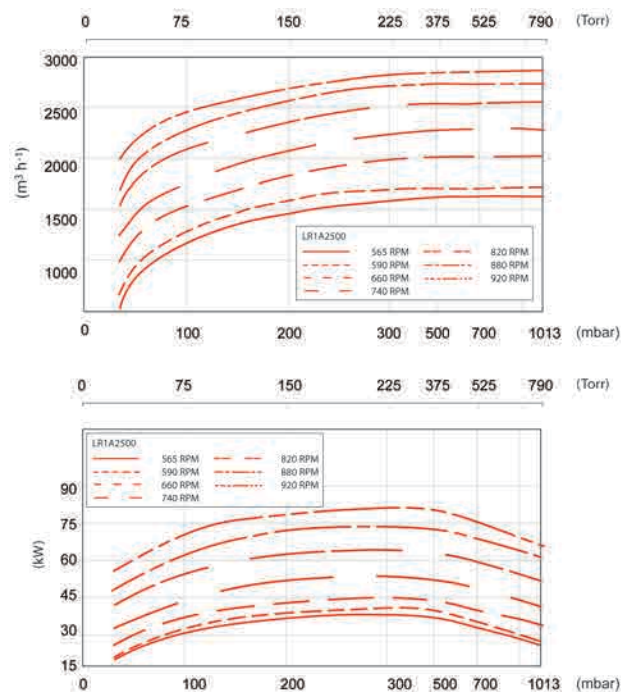

Technical Data

	50 Hz	60 Hz
Nominal capacity (saturated)	2500 m ³ h ⁻¹ 1500 CFM	2800 m ³ h ⁻¹ 1700 CFM
Suction pressure	33 mbar 25 Torr	33 mbar 25 Torr
Nominal speed	740 rpm	880 rpm
Nominal motor power	75 kW 100 HP	90 kW 125 HP

Ordering Information

Product Description	Order No.
LR1A2500 Liquid Ring Pump	LR1A2500

LR1A4000 Liquid Ring Pump



Edwards offers a full range of liquid ring pumps. The LR1A4000 provides a single-stage design and curved blade impellor with reinforcing rings for improved ruggedness, reducing noise and vibration.

All of our liquid ring pumps handle wet or dry gases, with high tolerance to liquid carry over. The LR1A Series has an enhanced bearing design enabling reduced internal clearances for improved efficiency. Pumps are available in cast iron and 316 stainless steel construction as standard with other materials and corrosion resistant coatings available.

Features & Benefits

- Optional central partition enabling dual vacuum duty operation
- Variable area discharge port for optimum performance at all inlet pressures
- Flange-mounted casing construction for extra rigidity
- Top and side inlet/outlet flange options for installations with limited headroom
- Packed gland, single and double mechanical seal options

Dimensions

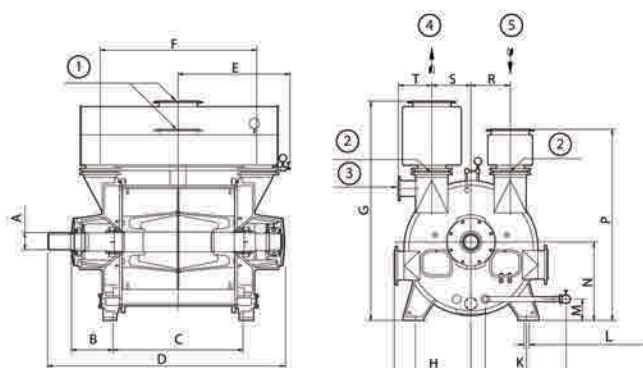

A (keyway)	B	C	D	E	F	G	H	J	
mm	106	315	790	1580	815	890	1360	480	670
Inch	4.17	12.40	31.10	62.20	32.09	35.04	53.54	18.90	26.38
K	M	N	P	R	S	T	L		
mm	495	137	475	1185	230	230	205	4 holes Ø 35	
Inch	19.49	5.39	18.70	46.65	9.06	9.06	8.07	1.38	

1. DN200 / PN10 2. DN150 / PN10 3. DN150 / PN10 4. Outlet 5. Inlet
*Flanges available in both DIN and ANSI standards

Applications

- The LR1A4000 is ideal for condenser evacuation, pulp and paper, filtration, flue gas desulphurization, vacuum forming and chemical and petrochemical applications.

Performance Curves

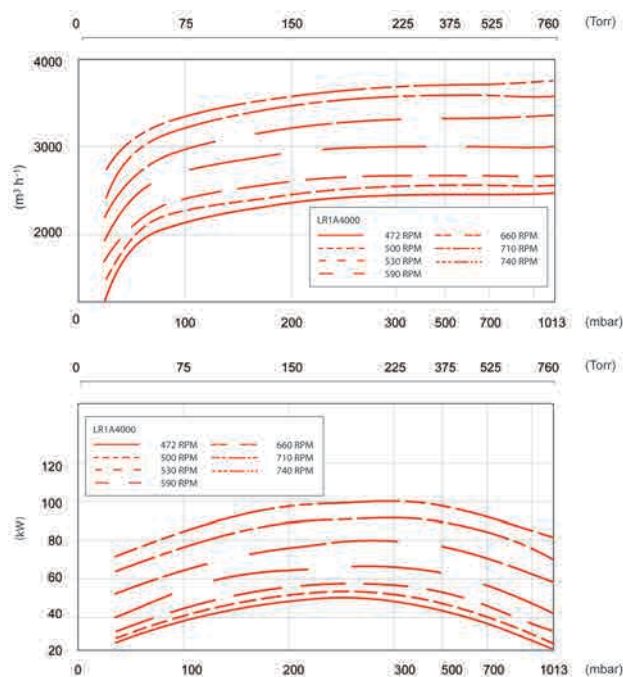

Technical Data

	50 Hz	60 Hz
Nominal capacity (saturated)	4000 m ³ h ⁻¹ 2350 CFM	3800 m ³ h ⁻¹ 2250 CFM
Suction pressure	33 mbar 25 Torr	33 mbar 25 Torr
Nominal speed	740 rpm	710 rpm
Nominal motor power	110 kW 150 HP	110 kW 150 HP

Ordering Information

Product Description	Order No.
LR1A4000 Liquid Ring Pump	LR1A4000

LR1A5000 Liquid Ring Pump

Edwards offers a full range of liquid ring pumps. The LR1A5000 provides a single-stage design and curved blade impellor with reinforcing rings for improved ruggedness, reducing noise and vibration.

All of our liquid ring pumps handle wet or dry gases, with high tolerance to liquid carry over. The LR1A Series has an enhanced bearing design enabling reduced internal clearances for improved efficiency. Pumps are available in cast iron and 316 stainless steel construction as standard with other materials and corrosion resistant coatings available.



Features & Benefits

- Optional central partition enabling dual vacuum duty operation
- Variable area discharge port for optimum performance at all inlet pressures
- Flange-mounted casing construction for extra rigidity
- Top and side inlet/outlet flange options for installations with limited headroom
- Packed gland, single and double mechanical seal options

Dimensions

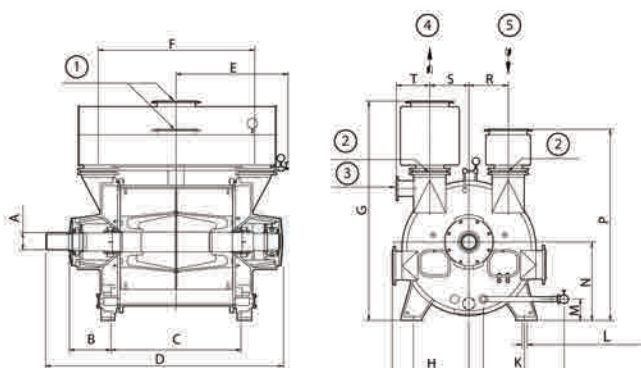

A (keyway)	B	C	D	E	F	G	H	J	
mm	106	315	900	1695	870	1000	1360	480	670
Inch	4.17	12.40	35.43	66.73	34.25	39.37	53.54	18.90	26.38
K	M	N	P	R	S	T	L		
mm	495	137	475	1185	230	230	205	4 holes Ø 35	
Inch	19.49	5.39	18.70	46.65	9.06	9.06	8.07	1.38	

1. DN200 / PN10 2. DN150 / PN10 3. DN150 / PN10 4. Outlet 5. Inlet
*Flanges available in both DIN and ANSI standards

Applications

- The LR1A5000 is ideal for condenser evacuation, pulp and paper, filtration, flue gas desulphurization, vacuum forming and chemical and petrochemical applications.

Performance Curves

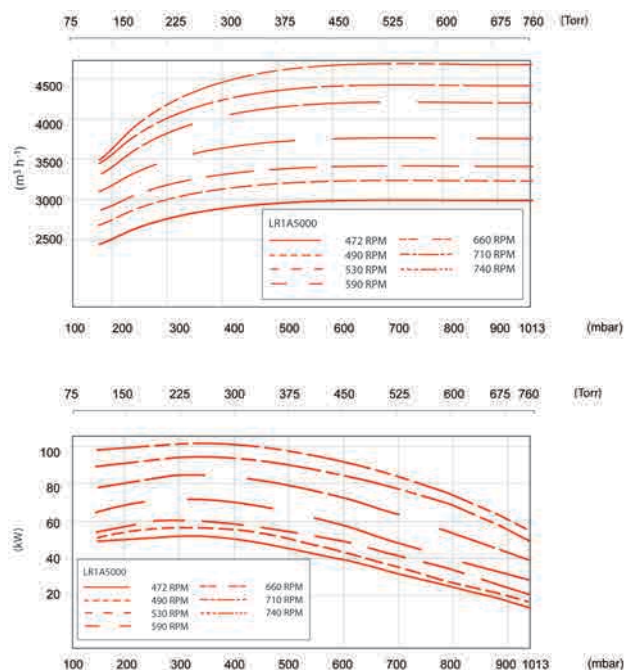

Technical Data

	50 Hz	60 Hz
Nominal capacity (saturated)	4600 m ³ h ⁻¹ 2700 CFM	4400 m ³ h ⁻¹ 2600 CFM
Suction pressure	160 mbar 120 Torr	160 mbar 120 Torr
Nominal speed	740 rpm	710 rpm
Nominal motor power	110 kW 150 HP	110 kW 150 HP

Ordering Information

Product Description	Order No.
LR1A5000 Liquid Ring Pump	LR1A5000

LR1A5500 Liquid Ring Pump



Edwards offers a full range of liquid ring pumps. The LR1A5500 provides a single-stage design and curved blade impellor with reinforcing rings for improved ruggedness, reducing noise and vibration.

All of our liquid ring pumps handle wet or dry gases, with high tolerance to liquid carry over. The LR1A Series has an enhanced bearing design enabling reduced internal clearances for improved efficiency. Pumps are available in cast iron and 316 stainless steel construction as standard with other materials and corrosion resistant coatings available.

Dimensions

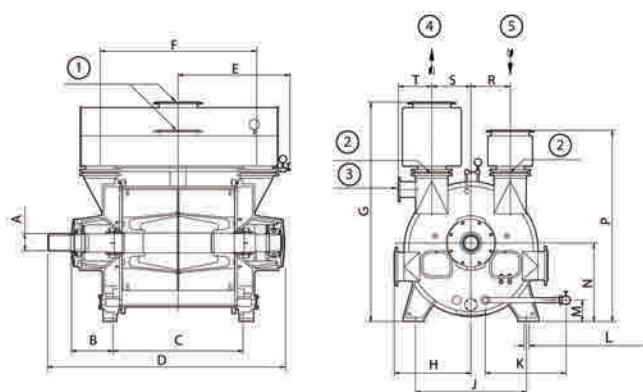

A (keyway)	B	C	D	E	F	G	H	J	
mm	127	335	910	1745	875	1132	1570	555	800
Inch	5.0	13.19	35.83	68.70	34.45	44.57	61.81	21.85	31.50
K	M	N	P	R	S	T	L		
mm	503	170	560	1370	285	285	245	4 holes Ø 24	
Inch	19.80	6.69	22.05	53.94	11.22	11.22	9.65	0.94	

1. DN250 / PN10 2. DN200 / PN10 3. DN125 / PN10 4. Outlet 5. Inlet
*Flanges available in both DIN and ANSI standards

Performance Curves

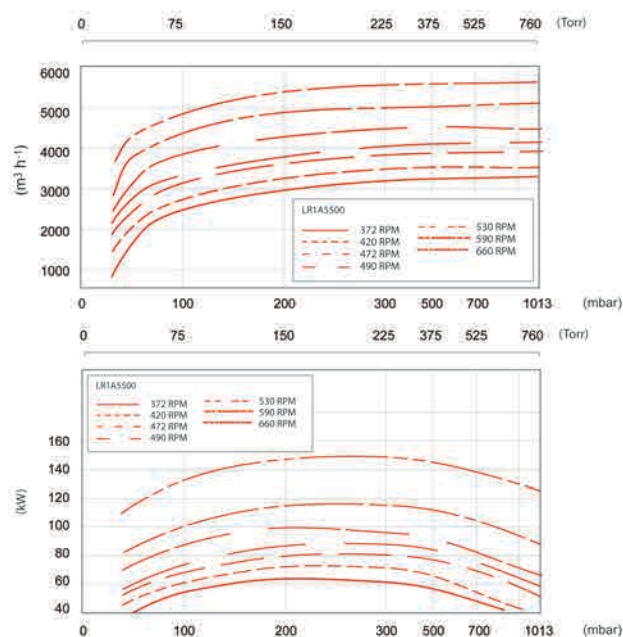

Technical Data

	50 Hz	60 Hz
Nominal capacity (saturated)	5300 m ³ h ⁻¹ 3100 CFM	5300 m ³ h ⁻¹ 3100 CFM
Suction pressure	33 mbar 25 Torr	33 mbar 25 Torr
Nominal speed	590 rpm	580 rpm
Nominal motor power	132 kW 200 HP	132 kW 200 HP

Ordering Information

Product Description	Order No.
LR1A5500 Liquid Ring Pump	LR1A5500

LR1A6500 Liquid Ring Pump

Edwards offers a full range of liquid ring pumps. The LR1A6500 provides a single-stage design and curved blade impellor with reinforcing rings for improved ruggedness, reducing noise and vibration.

All of our liquid ring pumps handle wet or dry gases, with high tolerance to liquid carry over. The LR1A Series has an enhanced bearing design enabling reduced internal clearances for improved efficiency. Pumps are available in cast iron and 316 stainless steel construction as standard with other materials and corrosion resistant coatings available.



Features & Benefits

- Optional central partition enabling dual vacuum duty operation
- Variable area discharge port for optimum performance at all inlet pressures
- Flange-mounted casing construction for extra rigidity
- Top and side inlet/outlet flange options for installations with limited headroom
- Packed gland, single and double mechanical seal options

Dimensions

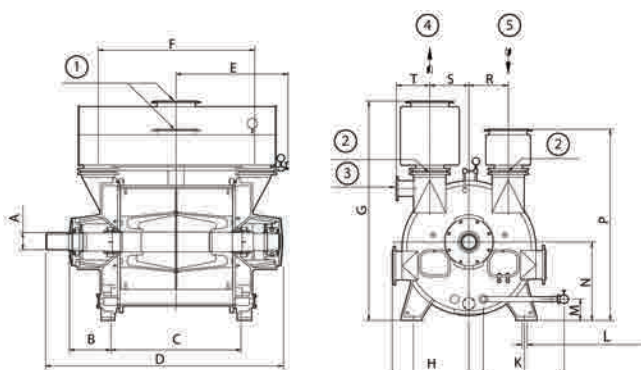

A (keyway)	B	C	D	E	F	G	H	J	
mm	127	335	1050	1885	945	1272	1570	555	800
Inch	5.0	13.19	41.34	74.21	37.20	50.08	61.81	21.85	31.50
K	M	N	P	R	S	T	L		
mm	503	170	560	1370	285	285	245	4 holes Ø 24	
Inch	19.80	6.69	22.05	53.94	11.22	11.22	9.65	0.94	

1. DN250 / PN10 2. DN200 / PN10 3. DN125 / PN10 4. Outlet 5. Inlet
*Flanges available in both DIN and ANSI standards

Applications

- The LR1A6500 is ideal for condenser evacuation, pulp and paper, filtration, flue gas desulphurization, vacuum forming and chemical and petrochemical applications.

Performance Curves

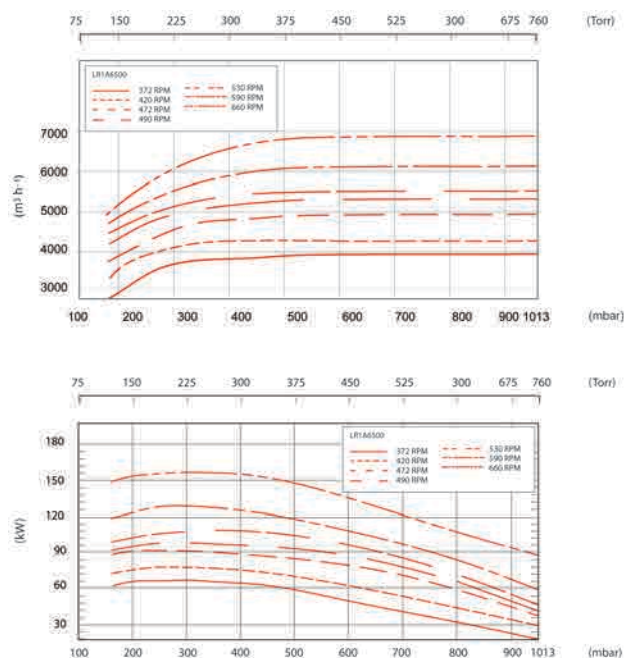

Technical Data

	50 Hz	60 Hz
Nominal capacity (saturated)	6200 m ³ h ⁻¹	6200 m ³ h ⁻¹
	3700 CFM	3700 CFM
Suction pressure	160 mbar	160 mbar
	120 Torr	120 Torr
Nominal speed	590 rpm	580 rpm
Nominal motor power	160 kW	160 kW
	200 HP	/200 HP

Ordering Information

Product Description	Order No.
LR1A6500 Liquid Ring Pump	LR1A6500

LR1A10000 Liquid Ring Pump



Edwards offers a full range of liquid ring pumps. The LR1A10000 provides a single-stage design and curved blade impellor with reinforcing rings for improved ruggedness, reducing noise and vibration.

All of our liquid ring pumps handle wet or dry gases, with high tolerance to liquid carry over. The LR1A Series has an enhanced bearing design enabling reduced internal clearances for improved efficiency. Pumps are available in cast iron and 316 stainless steel construction as standard with other materials and corrosion resistant coatings available.

Features & Benefits

- Optional central partition enabling dual vacuum duty operation
- Variable area discharge port for optimum performance at all inlet pressures
- Flange-mounted casing construction for extra rigidity
- Top and side inlet/outlet flange options for installations with limited headroom
- Packed gland, single and double mechanical seal options

Dimensions

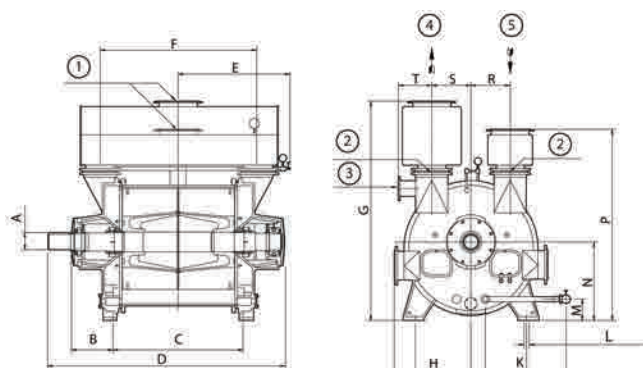

A (keyway)	B	C	D	E	F	G	H	J
mm	148	355	1260	2170	1067	1410	1865	655
Inch	5.83	13.98	49.61	85.43	41.61	55.51	73.43	25.79
K	M	N	P	R	S	T	L	
mm	689	180	670	1625	335	335	285	4 holes Ø 42
Inch	27.13	7.09	26.38	63.98	13.19	13.19	11.22	1.65

1. DN300 / PN10 2. DN250 / PN10 3. DN150 / PN10 4. Outlet 5. Inlet
*Flanges available in both DIN and ANSI standards

Applications

- The LR1A10000 is ideal for condenser evacuation, pulp and paper, filtration, flue gas desulphurization, vacuum forming and chemical and petrochemical applications.

Performance Curves

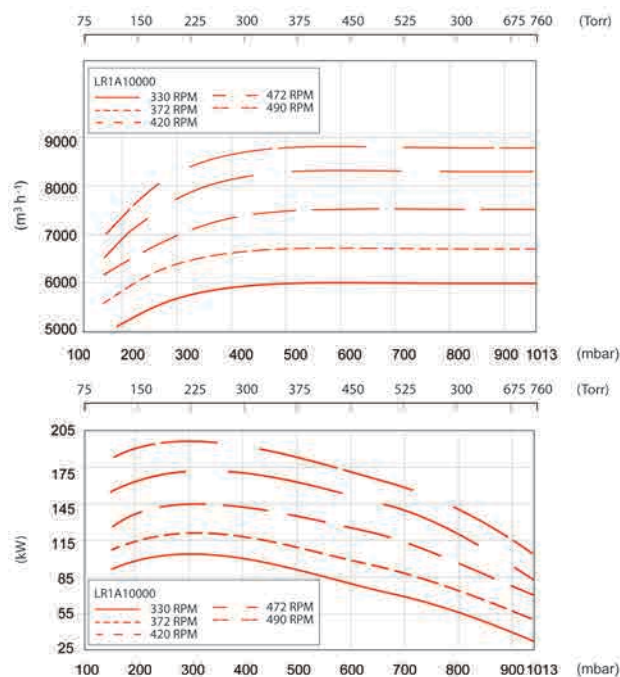

Technical Data

	50 Hz	60 Hz
Nominal capacity (saturated)	9000 m ³ h ⁻¹ 5300 CFM	9000 m ³ h ⁻¹ 5300 CFM
Suction pressure	160 mbar 120 Torr	160 mbar 120 Torr
Nominal speed	490 rpm	500 rpm
Nominal motor power	160 kW 200 HP	160 kW 200 HP

Ordering Information

Product Description	Order No.
LR1A10000 Liquid Ring Pump	LR1A10000

LR1A12000 Liquid Ring Pump

Edwards offers a full range of liquid ring pumps. The LR1A12000 provides a single-stage design and curved blade impellor with reinforcing rings for improved ruggedness, reducing noise and vibration.

All of our liquid ring pumps handle wet or dry gases, with high tolerance to liquid carry over. The LR1A Series has an enhanced bearing design enabling reduced internal clearances for improved efficiency. Pumps are available in cast iron and 316 stainless steel construction as standard with other materials and corrosion resistant coatings available.



Features & Benefits

- Optional central partition enabling dual vacuum duty operation
- Variable area discharge port for optimum performance at all inlet pressures
- Flange-mounted casing construction for extra rigidity
- Top and side inlet/outlet flange options for installations with limited headroom
- Packed gland, single and double mechanical seal options

Applications

- The LR1A12000 is ideal for condenser evacuation, pulp and paper, filtration, flue gas desulphurization, vacuum forming and chemical and petrochemical applications.

Dimensions

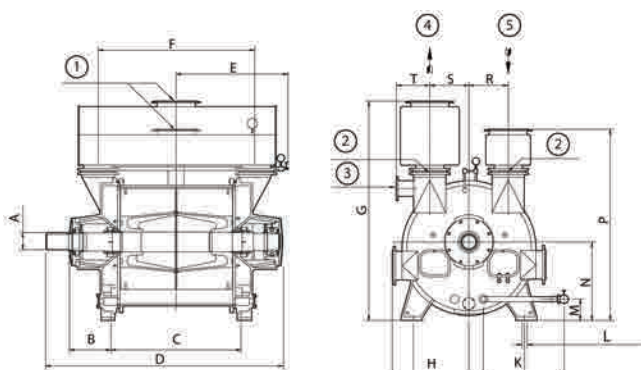

A (keyway)	B	C	D	E	F	G	H	J
mm	169	375	1270	2255	1460	2160	775	1120
Inch	6.65	14.76	50.0	88.78	57.49	85.04	30.51	44.09
K	M	N	P	R	S	T	L	
mm	858	215	800	1875	385	385	285	4 holes Ø 42
Inch	33.78	8.46	31.50	73.82	15.16	15.16	11.22	1.65

1. DN350 / PN10 2. DN300 / PN10 3. DN150 / PN10 4. Outlet 5. Inlet
*Flanges available in both DIN and ANSI standards

Performance Curves

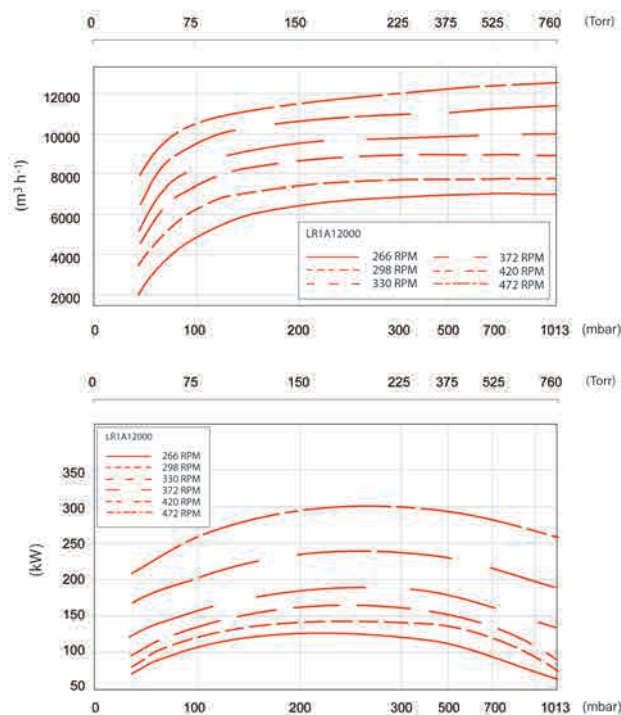

Technical Data

	50 Hz / 60 Hz
Nominal capacity (saturated)	11700 m ³ h ⁻¹ 6900 CFM
Suction pressure	33 mbar 25 Torr
Nominal speed	470 rpm
Nominal motor power	315 kW 450 HP

Ordering Information

Product Description	Order No.
LR1A12000 Liquid Ring Pump	LR1A12000

LR1A13000 Liquid Ring Pump



Edwards offers a full range of liquid ring pumps. The LR1A13000 provides a single-stage design and curved blade impellor with reinforcing rings for improved ruggedness, reducing noise and vibration.

All of our liquid ring pumps handle wet or dry gases, with high tolerance to liquid carry over. The LR1A Series has an enhanced bearing design enabling reduced internal clearances for improved efficiency. Pumps are available in cast iron and 316 stainless steel construction as standard with other materials and corrosion resistant coatings available.

Features & Benefits

- Optional central partition enabling dual vacuum duty operation
- Variable area discharge port for optimum performance at all inlet pressures
- Flange-mounted casing construction for extra rigidity
- Top and side inlet/outlet flange options for installations with limited headroom
- Packed gland, single and double mechanical seal options

Dimensions

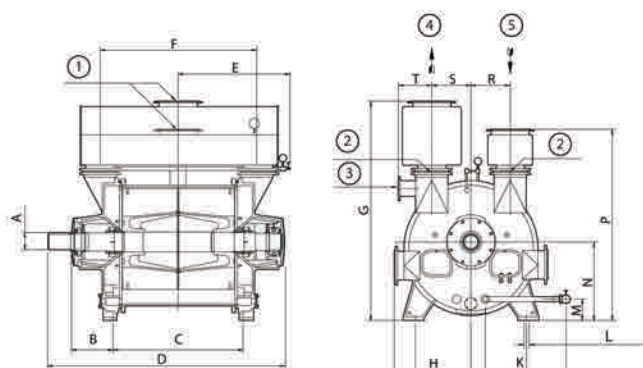

A (keyway)	B	C	D	E	F	G	H	J
mm	169	375	1450	2435	1640	2160	775	1120
Inch	6.65	14.76	57.09	95.87	64.57	85.04	30.51	44.09
K	M	N	P	R	S	T	L	
mm	858	215	800	1875	385	385	285	4 holes Ø 42
Inch	33.78	8.46	31.50	73.82	15.16	15.16	11.22	1.65

1. DN350 / PN10 2. DN300 / PN10 3. DN150 / PN10 4. Outlet 5. Inlet
*Flanges available in both DIN and ANSI standards

Applications

- The LR1A13000 is ideal for condenser evacuation, pulp and paper, filtration, flue gas desulphurization, vacuum forming and chemical and petrochemical applications.

Performance Curves

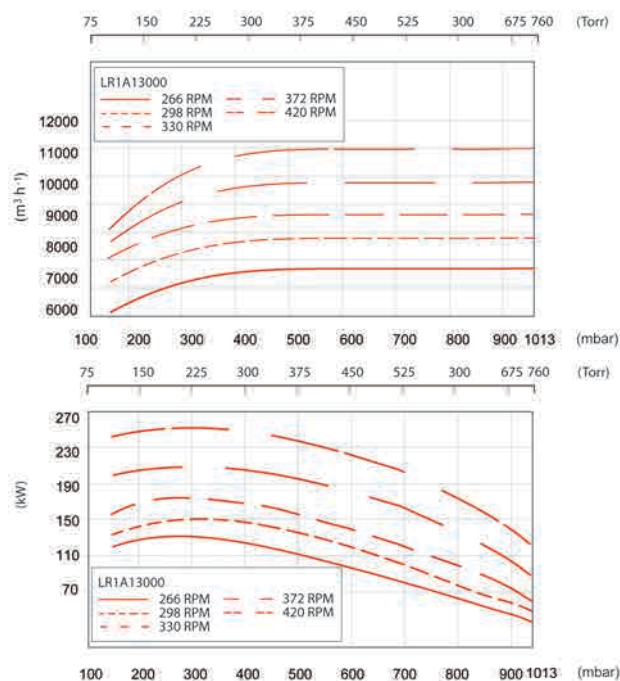

Technical Data

	50 Hz / 60 Hz
Nominal capacity (saturated)	12600 m ³ h ⁻¹ 7400 CFM
Suction pressure	160 mbar 120 Torr
Nominal speed	440 rpm
Nominal motor power	280 kW 400 HP

Ordering Information

Product Description	Order No.
LR1A13000 Liquid Ring Pump	LR1A13000

LR1A16000 Liquid Ring Pump

Edwards offers a full range of liquid ring pumps. The LR1A16000 provides a single-stage design and curved blade impellor with reinforcing rings for improved ruggedness, reducing noise and vibration.

All of our liquid ring pumps handle wet or dry gases, with high tolerance to liquid carry over. The LR1A Series has an enhanced bearing design enabling reduced internal clearances for improved efficiency. Pumps are available in cast iron and 316 stainless steel construction as standard with other materials and corrosion resistant coatings available.



Features & Benefits

- Optional central partition enabling dual vacuum duty operation
- Variable area discharge port for optimum performance at all inlet pressures
- Flange-mounted casing construction for extra rigidity
- Top and side inlet/outlet flange options for installations with limited headroom
- Packed gland, single and double mechanical seal options

Applications

- The LR1A16000 is ideal for condenser evacuation, pulp and paper, filtration, flue gas desulphurization, vacuum forming and chemical and petrochemical applications.

Dimensions

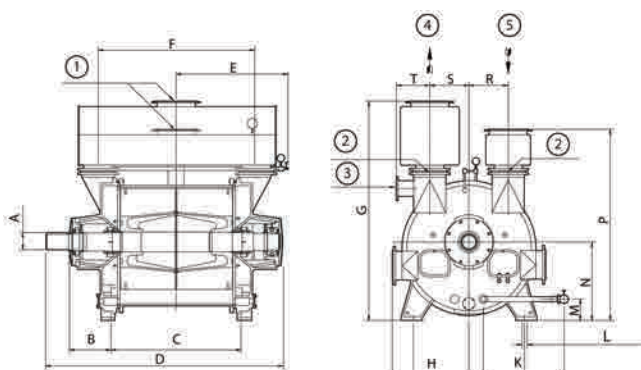

A (keyway)	B	C	D	E	F	G	H	J
mm	190	400	1480	2510	1706	2560	875	1320
Inch	7.48	15.75	58.27	98.82	67.17	100.79	34.45	51.97
K	M	N	P	R	S	T	L	
mm	925	244	950	2220	435	435	370	4 holes Ø 42
Inch	36.42	9.61	37.40	87.40	17.13	17.13	14.57	1.65

1. DN400 / PN10 2. DN350 / PN10 3. DN200 / PN10 4. Outlet 5. Inlet
*Flanges available in both DIN and ANSI standards

Performance Curves

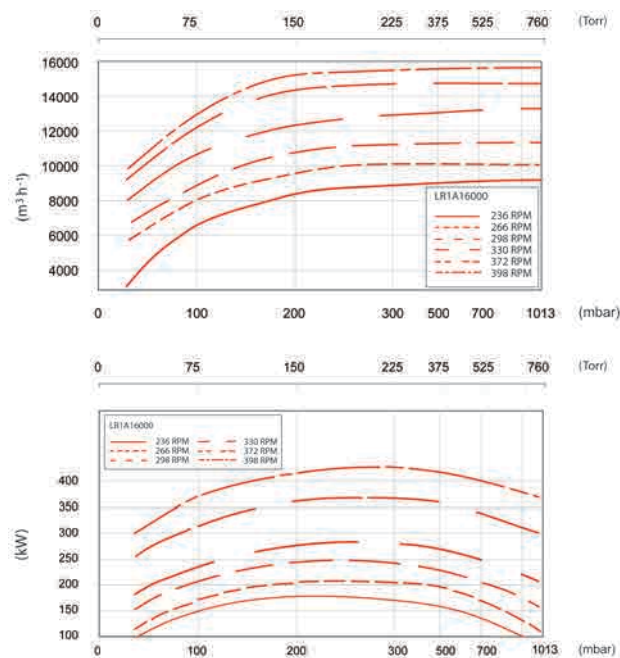

Technical Data

Nominal capacity (saturated)	50 Hz / 60 Hz 16200 m ³ h ⁻¹ 9500 CFM
Suction pressure	33 mbar 25 Torr
Nominal speed	390 rpm
Nominal motor power	450 kW 600 HP

Ordering Information

Product Description	Order No.
LR1A16000 Liquid Ring Pump	LR1A16000

LR1A19000 Liquid Ring Pump



Edwards offers a full range of liquid ring pumps. The LR1A19000 provides a single-stage design and curved blade impellor with reinforcing rings for improved ruggedness, reducing noise and vibration.

All of our liquid ring pumps handle wet or dry gases, with high tolerance to liquid carry over. The LR1A Series has an enhanced bearing design enabling reduced internal clearances for improved efficiency. Pumps are available in cast iron and 316 stainless steel construction as standard with other materials and corrosion resistant coatings available.

Features & Benefits

- Optional central partition enabling dual vacuum duty operation
- Variable area discharge port for optimum performance at all inlet pressures
- Flange-mounted casing construction for extra rigidity
- Top and side inlet/outlet flange options for installations with limited headroom
- Packed gland, single and double mechanical seal options

Dimensions

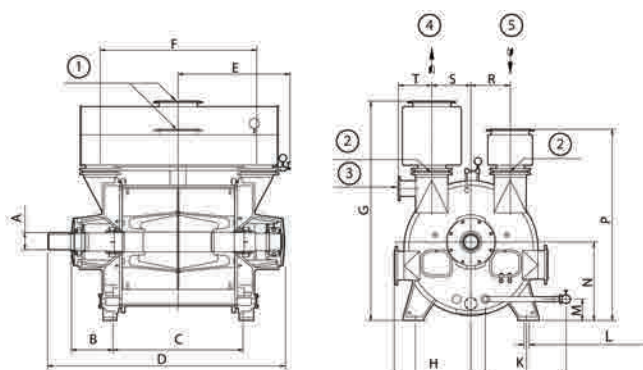

A (keyway)	B	C	D	E	F	G	H	J
mm	190	400	1700	2730	1926	2560	875	1320
Inch	7.48	15.75	66.93	107.48	75.83	100.79	34.45	51.97
K	M	N	P	R	S	T	L	
mm	925	244	950	2220	435	435	370	4 holes Ø 48
Inch	36.42	9.61	37.40	87.40	17.13	17.13	14.57	1.89

1. DN400 / PN10 2. DN350 / PN10 3. DN200 / PN10 4. Outlet 5. Inlet
*Flanges available in both DIN and ANSI standards

Applications

- The LR1A19000 is ideal for condenser evacuation, pulp and paper, filtration, flue gas desulphurization, vacuum forming and chemical and petrochemical applications.

Performance Curves

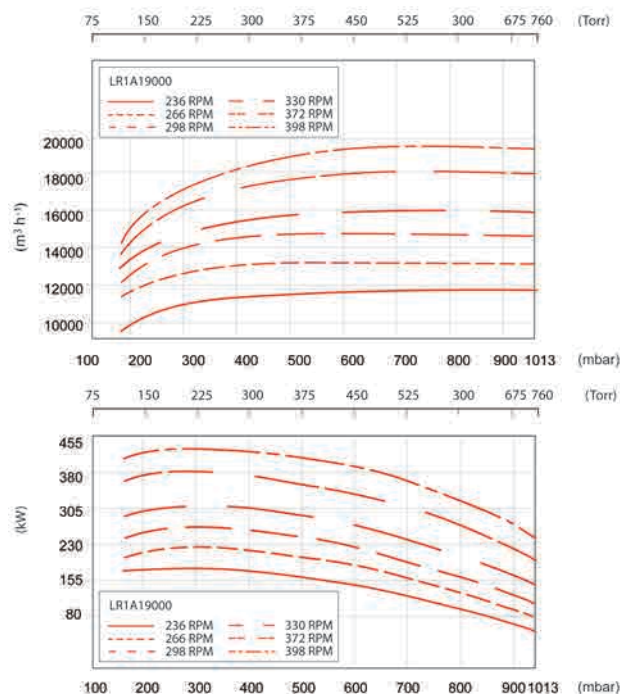

Technical Data

	50 Hz / 60 Hz
Nominal capacity (saturated)	19200 m ³ h ⁻¹ 11300 CFM
Suction pressure	160 mbar 120 Torr
Nominal speed	390 rpm
Nominal motor power	450 kW 600 HP

Ordering Information

Product Description	Order No.
LR1A19000 Liquid Ring Pump	LR1A19000

LR1A23000 Liquid Ring Pump

Edwards offers a full range of liquid ring pumps. The LR1A23000 provides a single-stage design and curved blade impellor with reinforcing rings for improved ruggedness, reducing noise and vibration.

All of our liquid ring pumps handle wet or dry gases, with high tolerance to liquid carry over. The LR1A Series has an enhanced bearing design enabling reduced internal clearances for improved efficiency. Pumps are available in cast iron and 316 stainless steel construction as standard with other materials and corrosion resistant coatings available.



Features & Benefits

- Optional central partition enabling dual vacuum duty operation
- Variable area discharge port for optimum performance at all inlet pressures
- Flange-mounted casing construction for extra rigidity
- Top and side inlet/outlet flange options for installations with limited headroom
- Packed gland, single and double mechanical seal options

Applications

- The LR1A23000 is ideal for condenser evacuation, pulp and paper, filtration, flue gas desulphurization, vacuum forming and chemical and petrochemical applications.

Dimensions

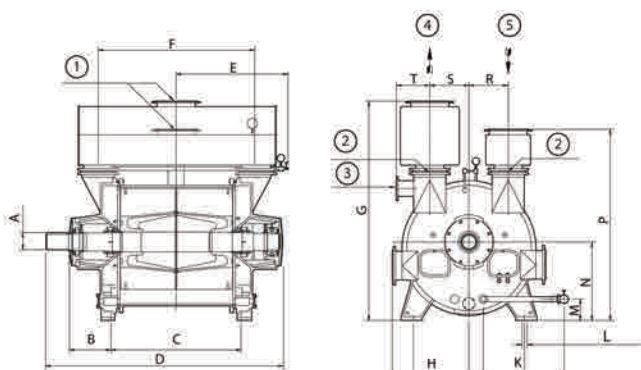

A (keyway)	B	C	D	E	F	G	H	J
mm	210	450	1720	2885	1980	2965	1025	1600
Inch	8.27	17.72	67.72	113.58	77.95	116.73	40.35	62.99
K	M	N	P	R	S	T	L	
mm	1125	290	1120	2560	490	490	370	4 holes Ø 48
Inch	44.29	11.42	44.09	100.79	19.29	19.29	14.57	1.89

1. DN500 / PN10 2. DN400 / PN10 3. DN200 / PN10 4. Outlet 5. Inlet
*Flanges available in both DIN and ANSI standards

Performance Curves

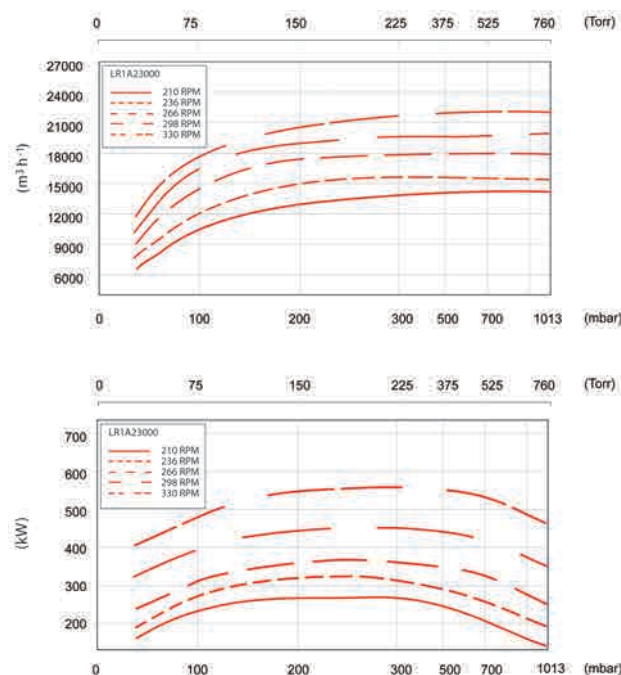

Technical Data

	50 Hz / 60 Hz
Nominal capacity (saturated)	22800 m ³ h ⁻¹ 13400 CFM
Suction pressure	33 mbar 25 Torr
Nominal speed	320 rpm
Nominal motor power	710 kW 1000 HP

Ordering Information

Product Description	Order No.
LR1A23000 Liquid Ring Pump	LR1A23000

LR1A26000 Liquid Ring Pump



Edwards offers a full range of liquid ring pumps. The LR1A26000 provides a single-stage design and curved blade impellor with reinforcing rings for improved ruggedness, reducing noise and vibration.

All of our liquid ring pumps handle wet or dry gases, with high tolerance to liquid carry over. The LR1A Series has an enhanced bearing design enabling reduced internal clearances for improved efficiency. Pumps are available in cast iron and 316 stainless steel construction as standard with other materials and corrosion resistant coatings available.

Features & Benefits

- Optional central partition enabling dual vacuum duty operation
- Variable area discharge port for optimum performance at all inlet pressures
- Flange-mounted casing construction for extra rigidity
- Top and side inlet/outlet flange options for installations with limited headroom
- Packed gland, single and double mechanical seal options

Dimensions

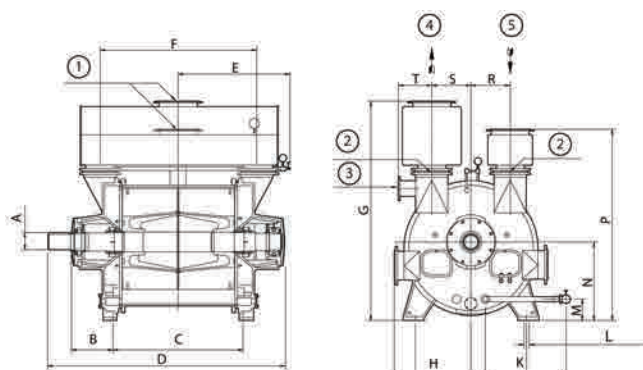

A (keyway)	B	C	D	E	F	G	H	J
mm	210	450	2020	3185	2280	2965	1025	1600
Inch	8.27	17.72	79.53	12.39	89.76	116.73	40.35	62.99
K	M	N	P	R	S	T	L	
mm	1125	290	1120	2560	490	490	370	4 holes Ø 48
Inch	44.29	11.42	44.09	100.79	19.29	19.29	14.57	1.89

1. DN500 / PN10 2. DN400 / PN10 3. DN200 / PN10 4. Outlet 5. Inlet
*Flanges available in both DIN and ANSI standards

Applications

- The LR1A26000 is ideal for condenser evacuation, pulp and paper, filtration, flue gas desulphurization, vacuum forming and chemical and petrochemical applications.

Performance Curves

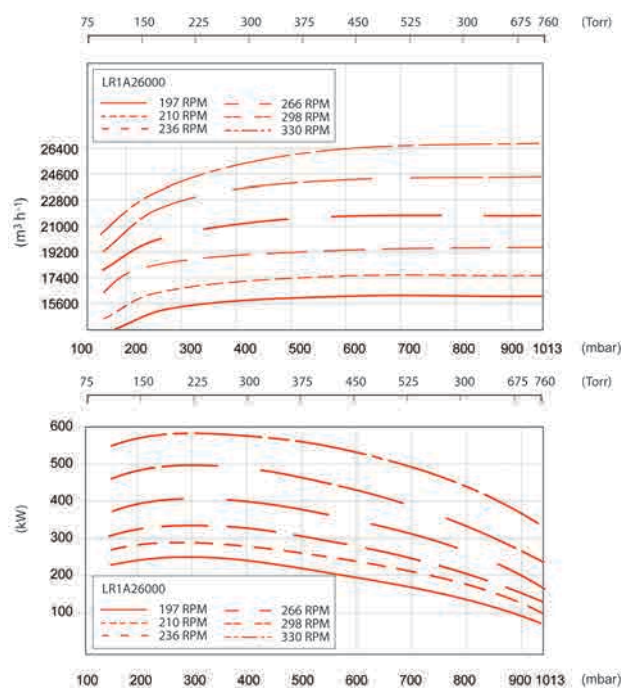

Technical Data

Nominal capacity (saturated)	50 Hz / 60 Hz 26100 m ³ h ⁻¹ 15300 CFM
Suction pressure	160 mbar 120 Torr
Nominal speed	320 rpm
Nominal motor power	710 kW 1000 HP

Ordering Information

Product Description	Order No.
LR1A26000 Liquid Ring Pump	LR1A26000

LR1B3500 Liquid Ring Pump

Edwards offers a full range of liquid ring pumps. The LR1B3500 provides a single-stage design and curved blade impellor with reinforcing rings for improved ruggedness, reducing noise and vibration.

All of our liquid ring pumps handle wet or dry gases, with high tolerance to liquid carry over. The LR1B Series has an enhanced bearing design enabling reduced internal clearances for improved efficiency. Pumps are available in cast iron and 316 stainless steel construction as standard with other materials and corrosion resistant coatings available.



Features & Benefits

- Optional central partition enabling dual vacuum duty operation
- Variable area discharge port for optimum performance at all inlet pressures
- Flange-mounted casing construction for extra rigidity
- Top and side inlet/outlet flange options for installations with limited headroom
- Packed gland, single and double mechanical seal options

Dimensions

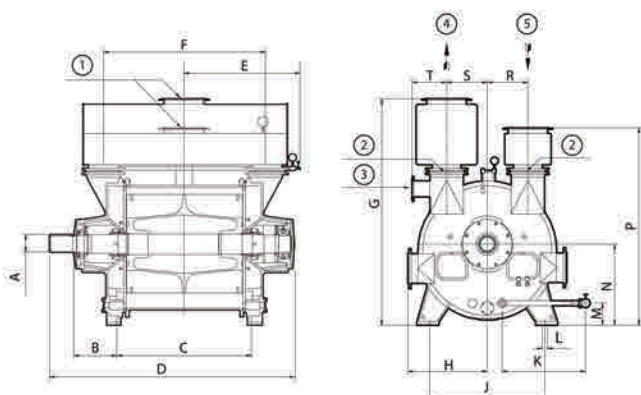

A (keyway)	B	C	D	E	F	G	H	J
mm	106	315	790	1580	815	890	1360	480
Inch	4.17	12.40	31.10	62.20	32.09	35.04	53.54	18.90
K	M	N	P	R	S	T	L	
mm	495	137	475	1185	230	230	205	4 holes Ø 35
Inch	19.49	5.39	18.70	46.65	9.06	9.06	8.07	1.38

1. DN200 / PN10 2. DN150 / PN10 3. DN100 / PN10 4. Outlet 5. Inlet
*Flanges available in both DIN and ANSI standards

Applications

- The LR1B3500 is ideal for fly ash conveying, pulp and paper, filtration, flue gas desulphurization, methane extraction in mining and chemical and petrochemical applications.

Performance Curves

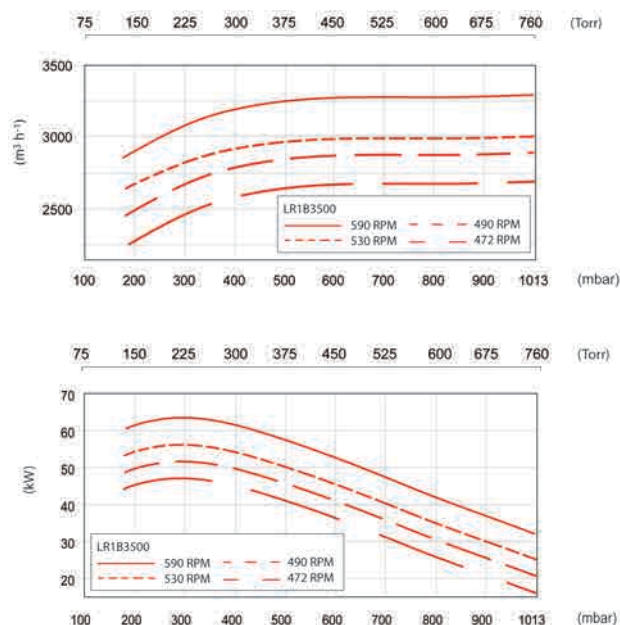

Technical Data

	50 Hz / 60 Hz
Nominal capacity (saturated)	3300 m ³ h ⁻¹ 1900 CFM
Suction pressure	160 mbar 120 Torr
Nominal speed	590 rpm
Nominal motor power	75 kW 100 HP

Ordering Information

Product Description	Order No.
LR1B3500 Liquid Ring Pump	LR1B3500

LR1B4500 Liquid Ring Pump



Edwards offers a full range of liquid ring pumps. The LR1B4500 provides a single-stage design and curved blade impellor with reinforcing rings for improved ruggedness, reducing noise and vibration.

All of our liquid ring pumps handle wet or dry gases, with high tolerance to liquid carry over. The LR1B Series has an enhanced bearing design enabling reduced internal clearances for improved efficiency. Pumps are available in cast iron and 316 stainless steel construction as standard with other materials and corrosion resistant coatings available.

Features & Benefits

- Optional central partition enabling dual vacuum duty operation
- Variable area discharge port for optimum performance at all inlet pressures
- Flange-mounted casing construction for extra rigidity
- Top and side inlet/outlet flange options for installations with limited headroom
- Packed gland, single and double mechanical seal options

Dimensions

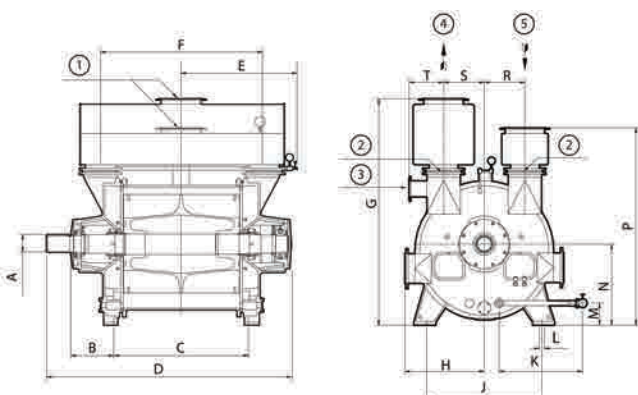

	A (keyway)	B	C	D	E	F	G	H	J
mm	106	315	990	1780	915	1090	1360	480	670
Inch	4.17	12.40	38.98	70.08	36.02	42.91	53.54	18.90	26.38
	K	M	N	P	R	S	T	L	
mm	495	137	475	1185	230	230	205	4 holes Ø 35	
Inch	19.49	5.39	18.70	46.65	9.06	9.06	8.07	1.38	

1. DN200 / PN10 2. DN150 / PN10 3. DN100 / PN10 4. Outlet 5. Inlet
*Flanges available in both DIN and ANSI standards

Applications

- The LR1B4500 is ideal for fly ash conveying, pulp and paper, filtration, flue gas desulphurization, methane extraction in mining and chemical and petrochemical applications.

Performance Curves

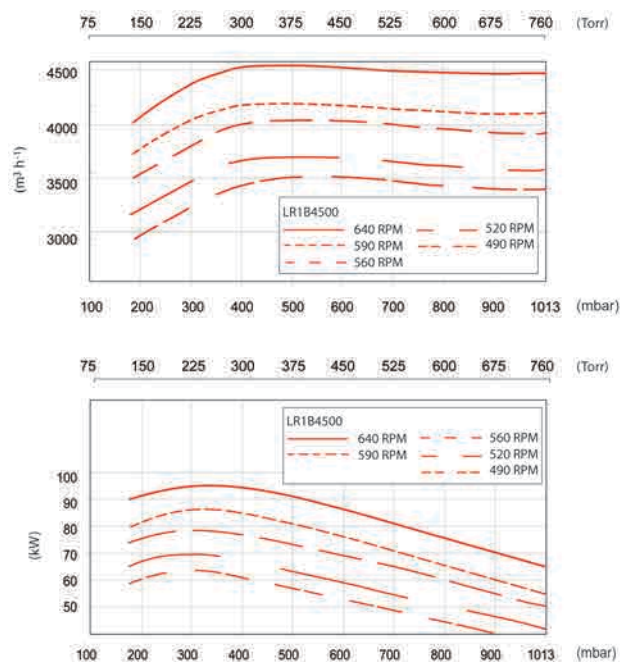

Technical Data

Nominal capacity (saturated)	50 Hz / 60 Hz 4500 m ³ h ⁻¹ 2800 CFM
Suction pressure	160 mbar 120 Torr
Nominal speed	640 rpm
Nominal motor power	110 kW 150 HP

Ordering Information

Product Description	Order No.
LR1B4500 Liquid Ring Pump	LR1B4500

LR1B6000 Liquid Ring Pump

Edwards offers a full range of liquid ring pumps. The LR1B6000 provides a single-stage design and curved blade impellor with reinforcing rings for improved ruggedness, reducing noise and vibration.

All of our liquid ring pumps handle wet or dry gases, with high tolerance to liquid carry over. The LR1B Series has an enhanced bearing design enabling reduced internal clearances for improved efficiency. Pumps are available in cast iron and 316 stainless steel construction as standard with other materials and corrosion resistant coatings available.



Features & Benefits

- Optional central partition enabling dual vacuum duty operation
- Variable area discharge port for optimum performance at all inlet pressures
- Flange-mounted casing construction for extra rigidity
- Top and side inlet/outlet flange options for installations with limited headroom
- Packed gland, single and double mechanical seal options

Dimensions

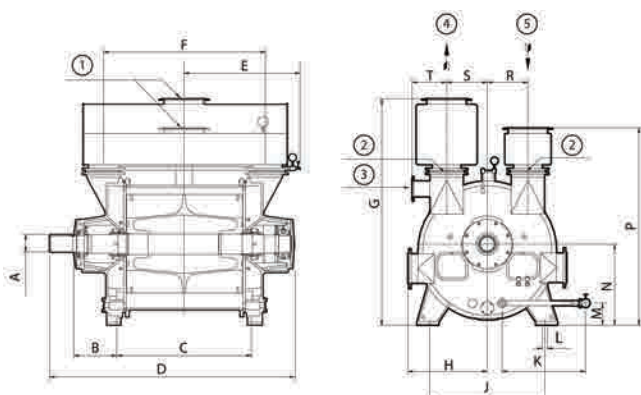

A (keyway)	B	C	D	E	F	G	H	J	
mm	127	335	1150	1985	1025	1290	1570	555	800
Inch	5.0	13.19	45.28	78.15	40.35	50.79	61.81	21.85	31.50
K	M	N	P	R	S	T	L		
mm	503	170	560	1370	285	285	245	4 holes Ø 35	
Inch	19.80	6.69	22.05	53.94	11.22	11.22	9.65	1.38	

1. DN250 / PN10 2. DN200 / PN10 3. DN125 / PN10 4. Outlet 5. Inlet
*Flanges available in both DIN and ANSI standards

Applications

- The LR1B6000 is ideal for fly ash conveying, pulp and paper, filtration, flue gas desulphurization, methane extraction in mining and chemical and petrochemical applications.

Performance Curves

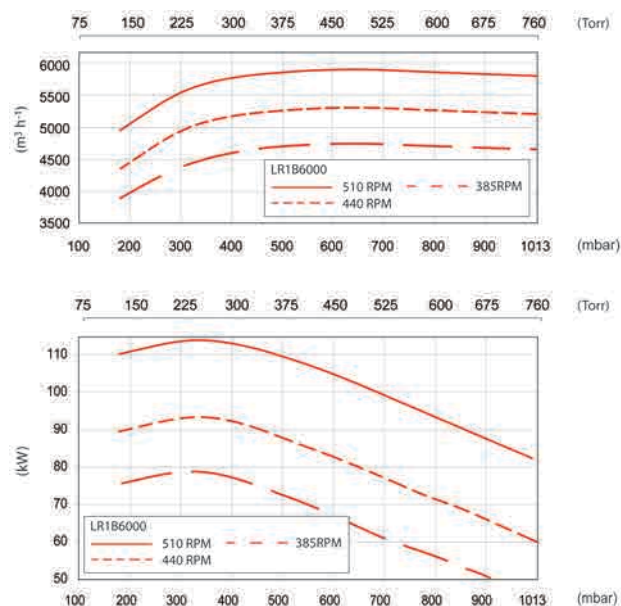

Technical Data

Nominal capacity (saturated)	50 Hz / 60 Hz 6000 m ³ h ⁻¹ 3500 CFM
Suction pressure	160 mbar 120 Torr
Nominal speed	510 rpm
Nominal motor power	132 kW 200 HP

Ordering Information

Product Description	Order No.
LR1B6000 Liquid Ring Pump	LR1B6000

LR1B7000 Liquid Ring Pump



Edwards offers a full range of liquid ring pumps. The LR1B7000 provides a single-stage design and curved blade impellor with reinforcing rings for improved ruggedness, reducing noise and vibration.

All of our liquid ring pumps handle wet or dry gases, with high tolerance to liquid carry over. The LR1B Series has an enhanced bearing design enabling reduced internal clearances for improved efficiency. Pumps are available in cast iron and 316 stainless steel construction as standard with other materials and corrosion resistant coatings available.

Features & Benefits

- Optional central partition enabling dual vacuum duty operation
- Variable area discharge port for optimum performance at all inlet pressures
- Flange-mounted casing construction for extra rigidity
- Top and side inlet/outlet flange options for installations with limited headroom
- Packed gland, single and double mechanical seal options

Dimensions

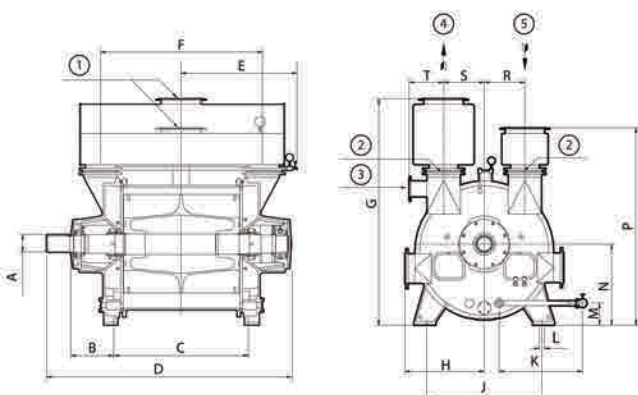

A (keyway)	B	C	D	E	F	G	H	J
mm	127	335	1150	1985	1025	1290	1570	800
Inch	5.0	13.19	45.28	78.15	40.35	50.79	61.81	31.50
K	M	N	P	R	S	T	L	
mm	503	170	560	1370	285	285	245	4 holes Ø 35
Inch	19.80	6.69	22.05	53.94	11.22	11.22	9.65	1.38

1. DN250 / PN10 2. DN200 / PN10 3. DN125 / PN10 4. Outlet 5. Inlet*Flanges available in both DIN and ANSI standards

Applications

- The LR1B7000 is ideal for fly ash conveying, pulp and paper, filtration, flue gas desulphurization, methane extraction in mining and chemical and petrochemical applications.

Performance Curves

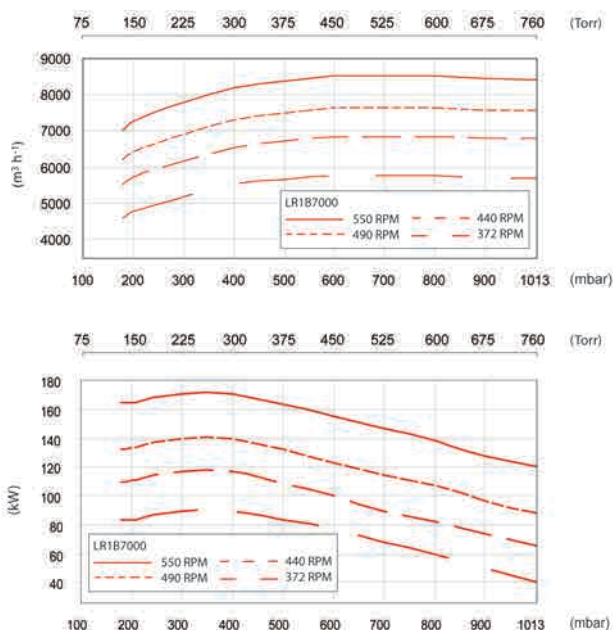

Technical Data

Nominal capacity (saturated)	50 Hz / 60 Hz 6000 m ³ h ⁻¹ 3500 CFM
Suction pressure	160 mbar 120 Torr
Nominal speed	510 rpm
Nominal motor power	132 kW 200 HP

Ordering Information

Product Description	Order No.
LR1B7000 Liquid Ring Pump	LR1B7000

LR1B8000 Liquid Ring Pump

Edwards offers a full range of liquid ring pumps. The LR1B8000 provides a single-stage design and curved blade impellor with reinforcing rings for improved ruggedness, reducing noise and vibration.

All of our liquid ring pumps handle wet or dry gases, with high tolerance to liquid carry over. The LR1B Series has an enhanced bearing design enabling reduced internal clearances for improved efficiency. Pumps are available in cast iron and 316 stainless steel construction as standard with other materials and corrosion resistant coatings available.



Features & Benefits

- Optional central partition enabling dual vacuum duty operation
- Variable area discharge port for optimum performance at all inlet pressures
- Flange-mounted casing construction for extra rigidity
- Top and side inlet/outlet flange options for installations with limited headroom
- Packed gland, single and double mechanical seal options

Dimensions

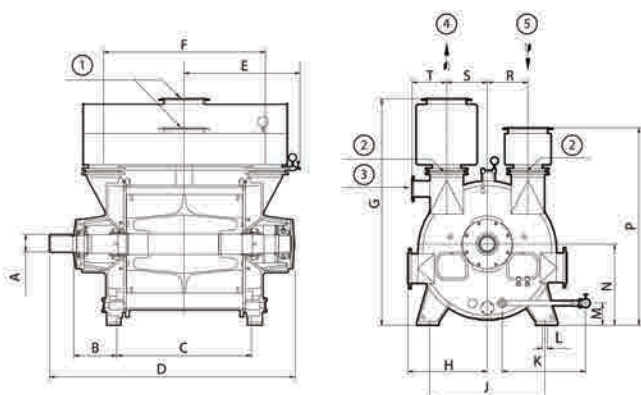

A (keyway)	B	C	D	E	F	G	H	J
mm	148	355	1110	2170	1002	1410	1865	655
Inch	5.83	13.98	43.70	85.43	39.49	55.51	73.43	25.79
K	M	N	P	R	S	T	L	
mm	689	180	670	1625	335	335	285	4 holes Ø 42
Inch	27.13	7.09	26.38	63.98	13.19	13.19	11.22	1.65

1. DN300 / PN10 2. DN250 / PN10 3. DN150 / PN10 4. Outlet 5. Inlet
*Flanges available in both DIN and ANSI standards

Applications

- The LR1B8000 is ideal for fly ash conveying, pulp and paper, filtration, flue gas desulphurization, methane extraction in mining and chemical and petrochemical applications.

Performance Curves

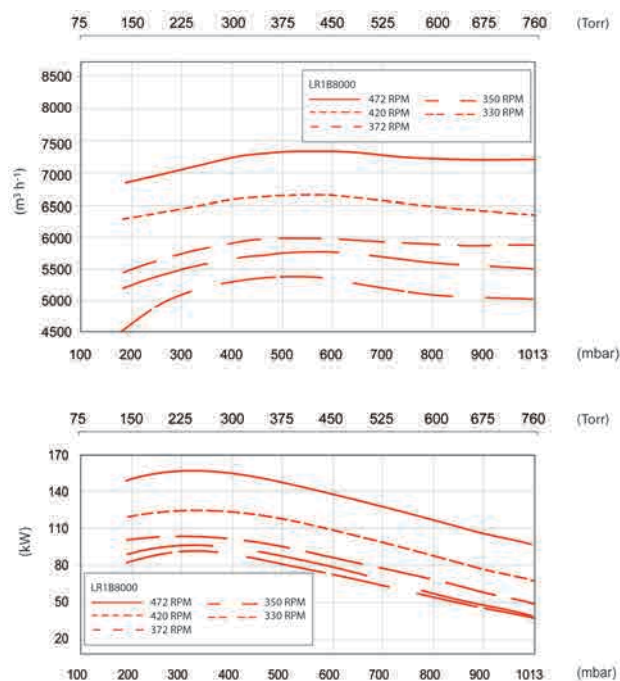

Technical Data

	50 Hz / 60 Hz
Nominal capacity (saturated)	7800 m ³ h ⁻¹ 4600 CFM
Suction pressure	160 mbar 120 Torr
Nominal speed	472 rpm
Nominal motor power	185 kW 250 HP

Ordering Information

Product Description	Order No.
LR1B8000 Liquid Ring Pump	LR1B8000

LR1B10000 Liquid Ring Pump



Edwards offers a full range of liquid ring pumps. The LR1B10000 provides a single-stage design and curved blade impellor with reinforcing rings for improved ruggedness, reducing noise and vibration.

All of our liquid ring pumps handle wet or dry gases, with high tolerance to liquid carry over. The LR1B Series has an enhanced bearing design enabling reduced internal clearances for improved efficiency. Pumps are available in cast iron and 316 stainless steel construction as standard with other materials and corrosion resistant coatings available.

Features & Benefits

- Optional central partition enabling dual vacuum duty operation
- Variable area discharge port for optimum performance at all inlet pressures
- Flange-mounted casing construction for extra rigidity
- Top and side inlet/outlet flange options for installations with limited headroom
- Packed gland, single and double mechanical seal options

Dimensions

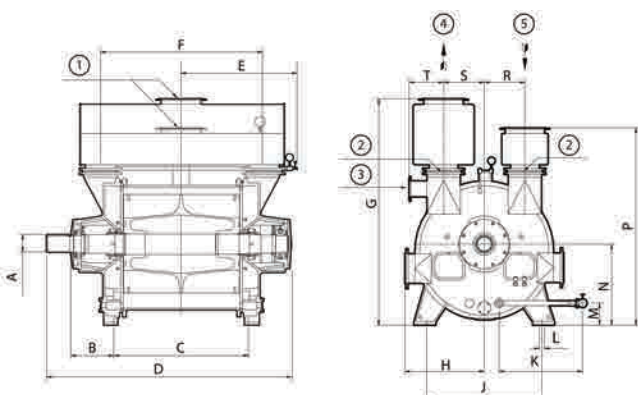

A (keyway)	B	C	D	E	F	G	H	J
mm	148	355	1480	2540	1167	1630	1865	655
Inch	5.83	13.98	58.27	100.00	45.94	64.17	73.43	25.79
K	M	N	P	R	S	T	L	
mm	689	180	670	1625	335	335	285	4 holes Ø 42
Inch	27.13	7.09	26.38	63.98	13.19	13.19	11.22	1.65

1. DN300 / PN10 2. DN250 / PN10 3. DN150 / PN10 4. Outlet 5. Inlet
*Flanges available in both DIN and ANSI standards

Applications

- The LR1B10000 is ideal for fly ash conveying, pulp and paper, filtration, flue gas desulphurization, methane extraction in mining and chemical and petrochemical applications.

Performance Curves

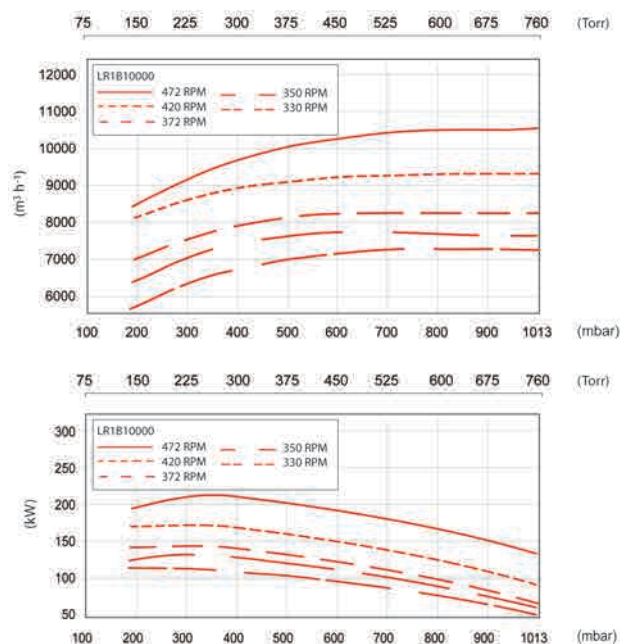

Technical Data

	50 Hz / 60 Hz
Nominal capacity (saturated)	10500 m ³ h ⁻¹ 6200 CFM
Suction pressure	160 mbar 120 Torr
Nominal speed	472 rpm
Nominal motor power	220 kW 300 HP

Ordering Information

Product Description	Order No.
LR1B10000 Liquid Ring Pump	LR1B10000

LR1B11000 Liquid Ring Pump

Edwards offers a full range of liquid ring pumps. The LR1B11000 provides a single-stage design and curved blade impellor with reinforcing rings for improved ruggedness, reducing noise and vibration.

All of our liquid ring pumps handle wet or dry gases, with high tolerance to liquid carry over. The LR1B Series has an enhanced bearing design enabling reduced internal clearances for improved efficiency. Pumps are available in cast iron and 316 stainless steel construction as standard with other materials and corrosion resistant coatings available.



Features & Benefits

- Optional central partition enabling dual vacuum duty operation
- Variable area discharge port for optimum performance at all inlet pressures
- Flange-mounted casing construction for extra rigidity
- Top and side inlet/outlet flange options for installations with limited headroom
- Packed gland, single and double mechanical seal options

Dimensions

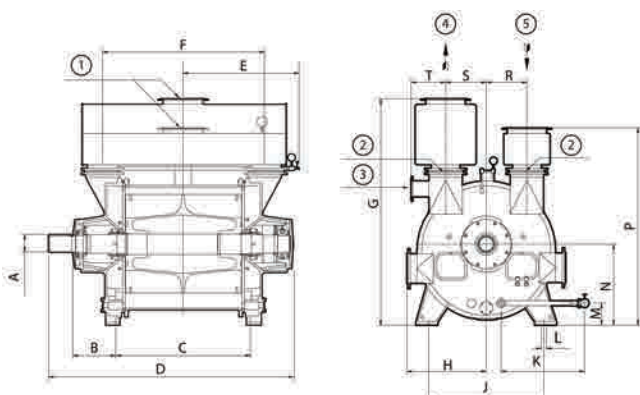

A (keyway)	B	C	D	E	F	G	H	J
mm	160	375	1450	2435	1260	1640	2160	775
Inch	6.30	14.76	57.09	95.87	49.61	64.57	85.04	30.51
	K	M	N	P	R	S	T	L
mm	858	215	800	1875	385	385	285	4 holes Ø 42
Inch	33.78	8.46	31.50	73.82	15.16	15.16	11.22	1.65

1. DN350 / PN10 2. DN300 / PN10 3. DN150 / PN10 4. Outlet 5. Inlet
*Flanges available in both DIN and ANSI standards

Applications

- The LR1B11000 is ideal for fly ash conveying, pulp and paper, filtration, flue gas desulphurization, methane extraction in mining and chemical and petrochemical applications.

Performance Curves

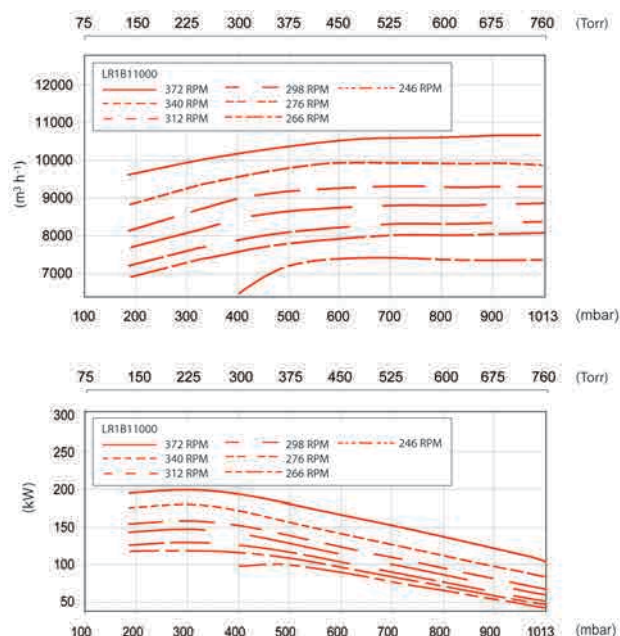

Technical Data

Nominal capacity (saturated)	50 Hz / 60 Hz 10800 m ³ h ⁻¹ 6300 CFM
Suction pressure	160 mbar 120 Torr
Nominal speed	372 rpm
Nominal motor power	220 kW 300 HP

Ordering Information

Product Description	Order No.
LR1B11000 Liquid Ring Pump	LR1B11000

LR1B12000 Liquid Ring Pump



Edwards offers a full range of liquid ring pumps. The LR1B12000 provides a single-stage design and curved blade impellor with reinforcing rings for improved ruggedness, reducing noise and vibration.

All of our liquid ring pumps handle wet or dry gases, with high tolerance to liquid carry over. The LR1B Series has an enhanced bearing design enabling reduced internal clearances for improved efficiency. Pumps are available in cast iron and 316 stainless steel construction as standard with other materials and corrosion resistant coatings available.

Features & Benefits

- Optional central partition enabling dual vacuum duty operation
- Variable area discharge port for optimum performance at all inlet pressures
- Flange-mounted casing construction for extra rigidity
- Top and side inlet/outlet flange options for installations with limited headroom
- Packed gland, single and double mechanical seal options

Dimensions

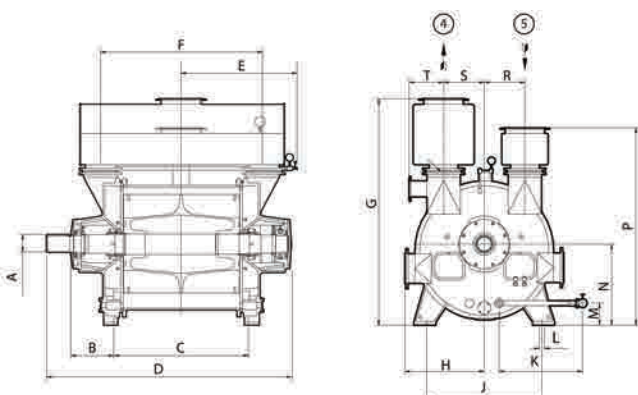

	A (keyway)	B	C	D	E	F	G	H	J
mm	140	355	1608	2518	1231	1758	1948	1200	950
Inch	5.51	13.98	63.31	99.13	48.47	69.21	76.70	47.24	37.40
	K	M	N	P	R	S	T	L	
mm	600	180	670	1663	335	335	285	4 holes Ø 42	
Inch	23.62	7.09	26.38	65.47	13.19	13.19	11.22	1.65	

4, Outlet 5, Inlet
*Flanges available in both DIN and ANSI standards

Applications

- The LR1B12000 is ideal for fly ash conveying, pulp and paper, filtration, flue gas desulphurization, methane extraction in mining and chemical and petrochemical applications.

Performance Curves

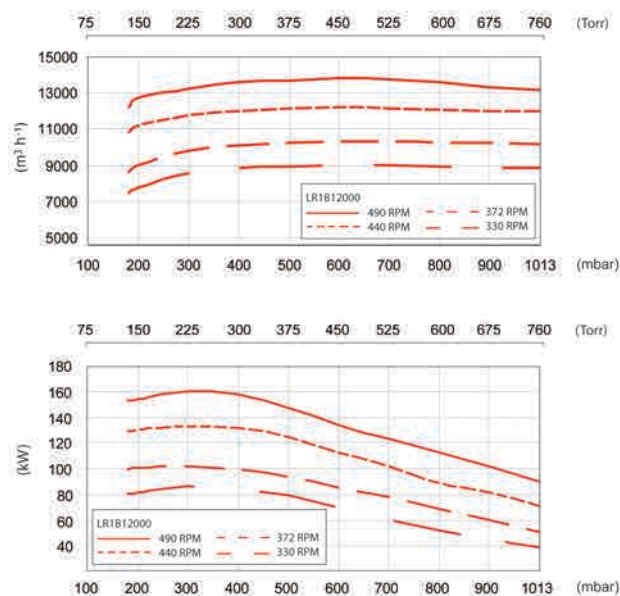

Technical Data

	50 Hz / 60 Hz
Nominal capacity (saturated)	13800 m ³ h ⁻¹ 8100 CFM
Suction pressure	180 mbar 135 Torr
Nominal speed	490 rpm
Nominal motor power	300 kW 400 HP

Ordering Information

Product Description	Order No.
LR1B12000 Liquid Ring Pump	LR1B12000

LR1B13000 Liquid Ring Pump

Edwards offers a full range of liquid ring pumps. The LR1B13000 provides a single-stage design and curved blade impellor with reinforcing rings for improved ruggedness, reducing noise and vibration.

All of our liquid ring pumps handle wet or dry gases, with high tolerance to liquid carry over. The LR1B Series has an enhanced bearing design enabling reduced internal clearances for improved efficiency. Pumps are available in cast iron and 316 stainless steel construction as standard with other materials and corrosion resistant coatings available.



Features & Benefits

- Optional central partition enabling dual vacuum duty operation
- Variable area discharge port for optimum performance at all inlet pressures
- Flange-mounted casing construction for extra rigidity
- Top and side inlet/outlet flange options for installations with limited headroom
- Packed gland, single and double mechanical seal options

Dimensions

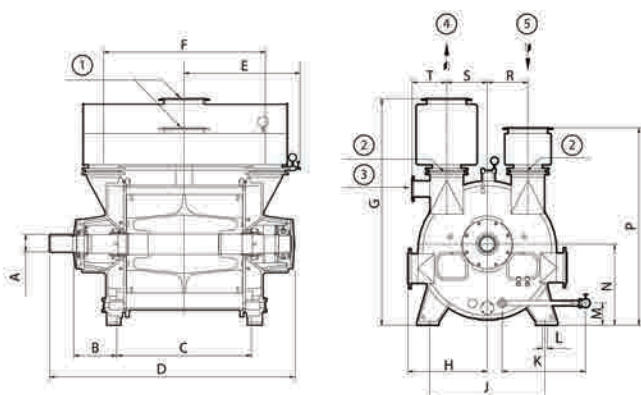

A (keyway)	B	C	D	E	F	G	H	J
mm	160	375	1670	2655	1370	1860	2160	775
Inch	6.30	14.76	65.75	104.53	53.94	73.23	85.04	30.51
	K	M	N	P	R	S	T	L
mm	858	215	800	1875	385	385	285	4 holes Ø 42
Inch	33.78	8.46	31.50	73.82	15.16	15.16	11.22	1.65

1. DN350 / PN10 2. DN300 / PN10 3. DN150 / PN10 4. Outlet 5. Inlet
*Flanges available in both DIN and ANSI standards

Applications

- The LR1B13000 is ideal for fly ash conveying, pulp and paper, filtration, flue gas desulphurization, methane extraction in mining and chemical and petrochemical applications.

Performance Curves

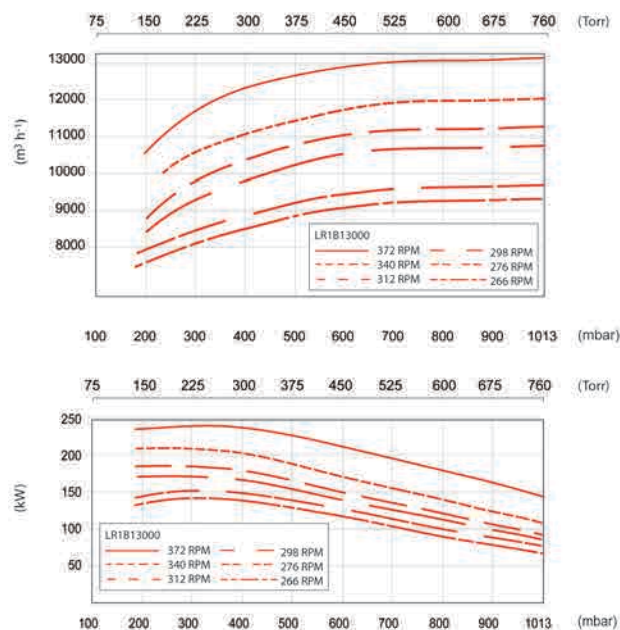

Technical Data

	50 Hz / 60 Hz
Nominal capacity (saturated)	13500 m ³ h ⁻¹ 7900 CFM
Suction pressure	160 mbar 120 Torr
Nominal speed	372 rpm
Nominal motor power	250 kW 350 HP

Ordering Information

Product Description	Order No.
LR1B13000 Liquid Ring Pump	LR1B13000

LR1B14000 Liquid Ring Pump



Edwards offers a full range of liquid ring pumps. The LR1B14000 provides a single-stage design and curved blade impellor with reinforcing rings for improved ruggedness, reducing noise and vibration.

All of our liquid ring pumps handle wet or dry gases, with high tolerance to liquid carry over. The LR1B Series has an enhanced bearing design enabling reduced internal clearances for improved efficiency. Pumps are available in cast iron and 316 stainless steel construction as standard with other materials and corrosion resistant coatings available.

Features & Benefits

- Optional central partition enabling dual vacuum duty operation
- Variable area discharge port for optimum performance at all inlet pressures
- Flange-mounted casing construction for extra rigidity
- Top and side inlet/outlet flange options for installations with limited headroom
- Packed gland, single and double mechanical seal options

Dimensions

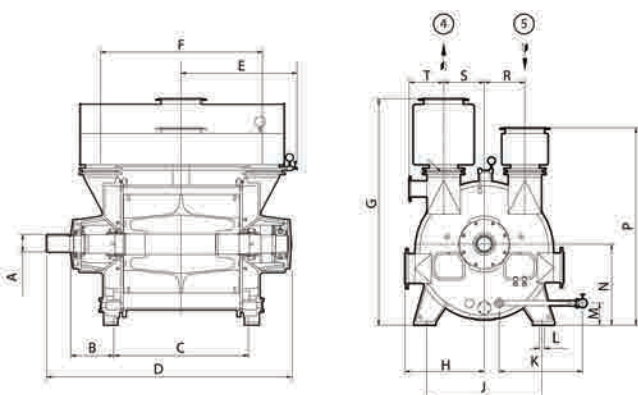

A (keyway)	B	C	D	E	F	G	H	J
mm	160	375	1820	2805	1445	2010	2263	1120
Inch	6.30	14.76	71.65	110.43	56.89	79.13	89.09	44.09
K	M	N	P	R	S	T	L	
mm	690	215	800	1923	385	385	367	4 holes Ø 42
Inch	27.17	8.46	31.50	75.71	15.16	15.16	14.45	1.65

4. Outlet 5. Inlet
*Flanges available in both DIN and ANSI standards

Technical Data

	50 Hz / 60 Hz
Nominal capacity (saturated)	17100 m ³ h ⁻¹ 10000 CFM
Suction pressure	180 mbar 135 Torr
Nominal speed	395 rpm
Nominal motor power	400 kW 500 HP

Applications

- The LR1B14000 is ideal for fly ash conveying, pulp and paper, filtration, flue gas desulphurization, methane extraction in mining and chemical and petrochemical applications.

Performance Curves

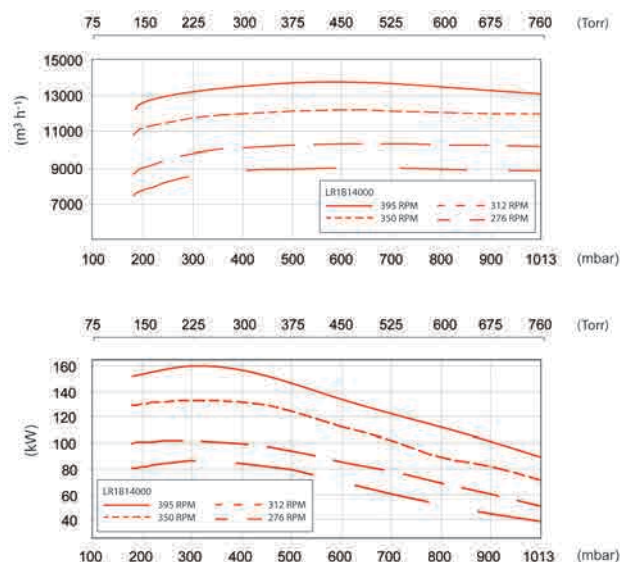

Ordering Information

Product Description	Order No.
LR1B14000 Liquid Ring Pump	LR1B14000

LR1B15000 Liquid Ring Pump

Edwards offers a full range of liquid ring pumps. The LR1B15000 provides a single-stage design and curved blade impellor with reinforcing rings for improved ruggedness, reducing noise and vibration.

All of our liquid ring pumps handle wet or dry gases, with high tolerance to liquid carry over. The LR1B Series has an enhanced bearing design enabling reduced internal clearances for improved efficiency. Pumps are available in cast iron and 316 stainless steel construction as standard with other materials and corrosion resistant coatings available.



Features & Benefits

- Optional central partition enabling dual vacuum duty operation
- Variable area discharge port for optimum performance at all inlet pressures
- Flange-mounted casing construction for extra rigidity
- Top and side inlet/outlet flange options for installations with limited headroom
- Packed gland, single and double mechanical seal options

Dimensions

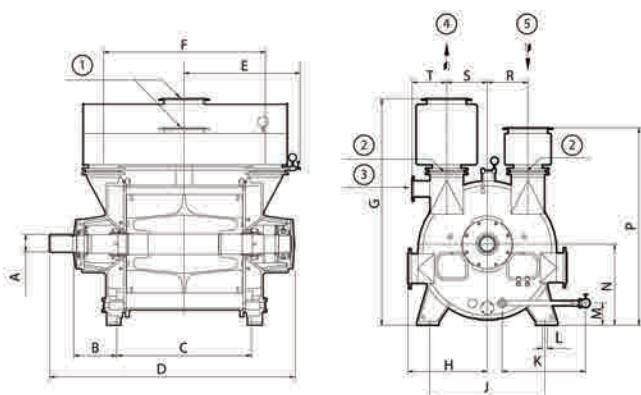

A (keyway)	B	C	D	E	F	G	H	J
mm	169	375	1670	2730	1370	1860	2160	775
Inch	6.65	14.76	65.75	107.48	53.94	73.23	85.04	30.51
	K	M	N	P	R	S	T	L
mm	858	215	800	1875	385	385	285	4 holes Ø 42
Inch	33.78	8.46	31.50	73.82	15.16	15.16	11.22	1.65

1. DN400 / PN10 2. DN350 / PN10 3. DN200 / PN10 4. Outlet 5. Inlet
*Flanges available in both DIN and ANSI standards

Applications

- The LR1B15000 is ideal for fly ash conveying, pulp and paper, filtration, flue gas desulphurization, methane extraction in mining and chemical and petrochemical applications.

Performance Curves

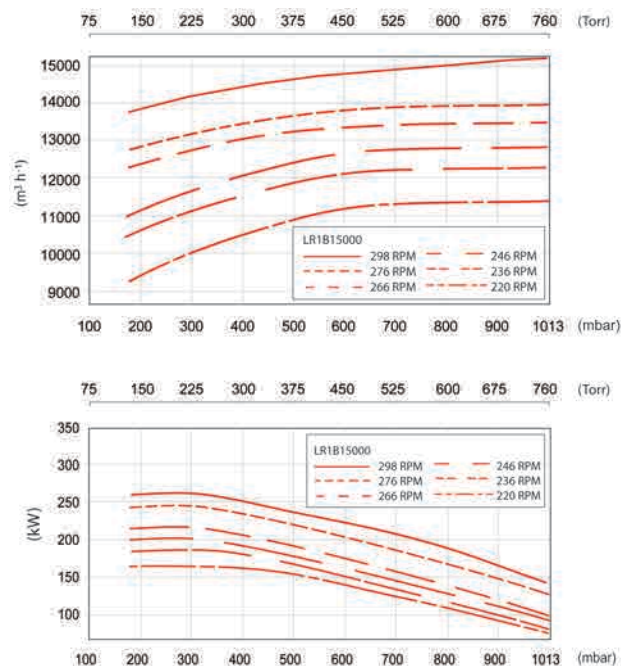

Technical Data

	50 Hz / 60 Hz
Nominal capacity (saturated)	15300 m ³ h ⁻¹ 9000 CFM
Suction pressure	160 mbar 120 Torr
Nominal speed	298 rpm
Nominal motor power	280 kW 400 HP

Ordering Information

Product Description	Order No.
LR1B15000 Liquid Ring Pump	LR1B15000

LR1B18000 Liquid Ring Pump



Edwards offers a full range of liquid ring pumps. The LR1B18000 provides a single-stage design and curved blade impellor with reinforcing rings for improved ruggedness, reducing noise and vibration.

All of our liquid ring pumps handle wet or dry gases, with high tolerance to liquid carry over. The LR1B Series has an enhanced bearing design enabling reduced internal clearances for improved efficiency. Pumps are available in cast iron and 316 stainless steel construction as standard with other materials and corrosion resistant coatings available.

Features & Benefits

- Optional central partition enabling dual vacuum duty operation
- Variable area discharge port for optimum performance at all inlet pressures
- Flange-mounted casing construction for extra rigidity
- Top and side inlet/outlet flange options for installations with limited headroom
- Packed gland, single and double mechanical seal options

Dimensions

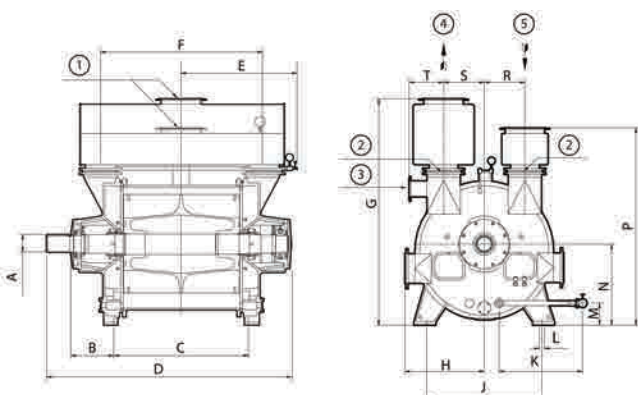

A (keyway)	B	C	D	E	F	G	H	J	
mm	190	400	1950	2980	1548	2176	2560	875	1320
Inch	7.48	15.75	76.77	117.32	60.94	85.67	100.79	34.45	51.97
K	M	N	P	R	S	T	L		
mm	925	244	950	2220	435	435	370	4 holes Ø 48	
Inch	36.42	9.61	37.40	87.40	17.13	17.13	14.57	1.89	

1. DN400 / PN10 2. DN350 / PN10 3. DN200 / PN10 4. Outlet 5. Inlet

Applications

- The LR1B18000 is ideal for fly ash conveying, pulp and paper, filtration, flue gas desulphurization, methane extraction in mining and chemical and petrochemical applications.

Performance Curves

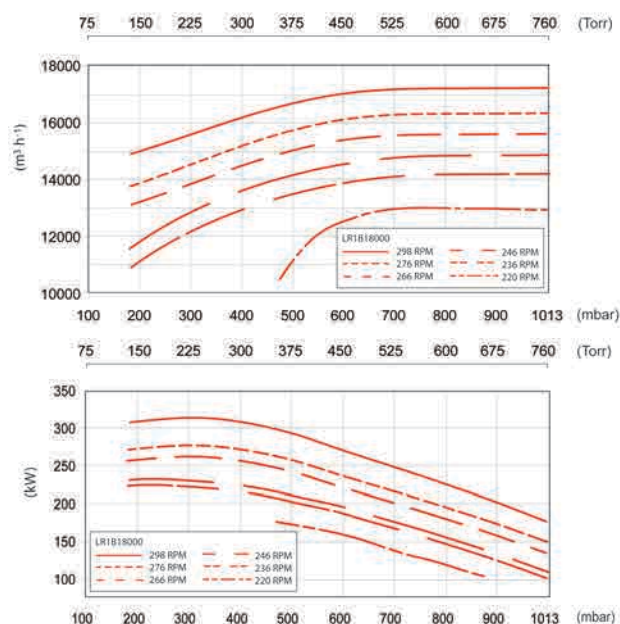

Technical Data

	50 Hz / 60 Hz
Nominal capacity (saturated)	17400 m ³ h ⁻¹ 10000 CFM
Suction pressure	160 mbar 120 Torr
Nominal speed	298 rpm
Nominal motor power	355 kW 500 HP

Ordering Information

Product Description	Order No.
LR1B18000 Liquid Ring Pump	LR1B18000

LR1B21000 Liquid Ring Pump

Edwards offers a full range of liquid ring pumps. The LR1B21000 provides a single-stage design and curved blade impellor with reinforcing rings for improved ruggedness, reducing noise and vibration.

All of our liquid ring pumps handle wet or dry gases, with high tolerance to liquid carry over. The LR1B Series has an enhanced bearing design enabling reduced internal clearances for improved efficiency. Pumps are available in cast iron and 316 stainless steel construction as standard with other materials and corrosion resistant coatings available.



Features & Benefits

- Optional central partition enabling dual vacuum duty operation
- Variable area discharge port for optimum performance at all inlet pressures
- Flange-mounted casing construction for extra rigidity
- Top and side inlet/outlet flange options for installations with limited headroom
- Packed gland, single and double mechanical seal options

Applications

- The LR1B21000 is ideal for fly ash conveying, pulp and paper, filtration, flue gas desulphurization, methane extraction in mining and chemical and petrochemical applications.

Dimensions

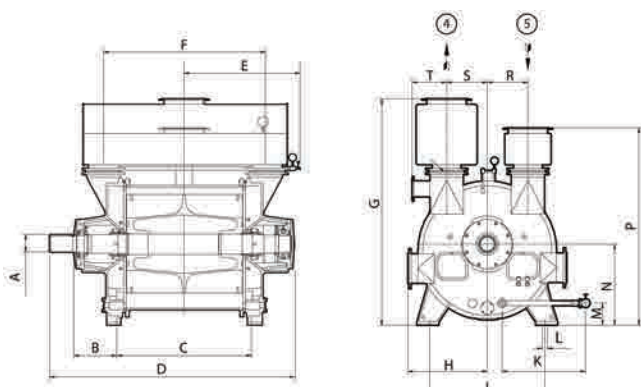

A (keyway)	B	C	D	E	F	G	H	J
mm	180	400	2129	3159	1638	2355	2688	1620
Inch	7.09	15.75	83.82	124.37	64.49	92.72	105.83	63.78
K	M	N	P	R	S	T	L	
mm	1025	244	950	2285	435	435	370	4 holes Ø 48
Inch	40.35	9.61	37.40	89.96	17.13	17.13	14.57	1.89

4. Outlet 5. Inlet
*Flanges available in both DIN and ANSI standards

Performance Curves

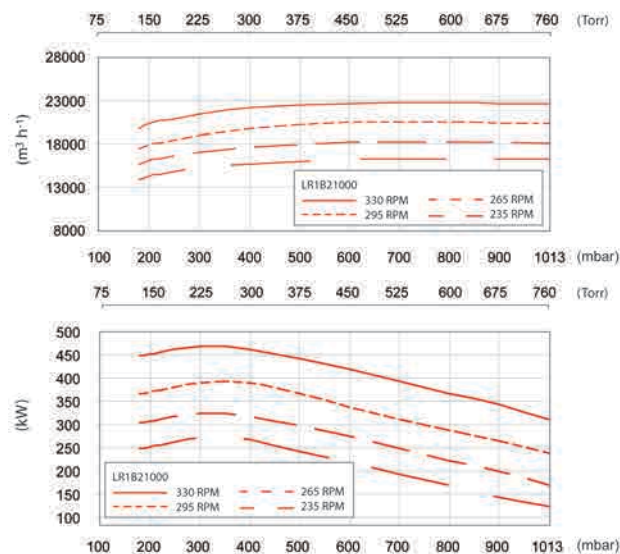

Technical Data

	50 Hz / 60 Hz
Nominal capacity (saturated)	22500 m ³ h ⁻¹ 13250 CFM
Suction pressure	180 mbar 135 Torr
Nominal speed	330 rpm
Nominal motor power	550 kW 750 HP

Ordering Information

Product Description	Order No.
LR1B21000 Liquid Ring Pump	LR1B21000

LR1B22000 Liquid Ring Pump



Edwards offers a full range of liquid ring pumps. The LR1B22000 provides a single-stage design and curved blade impellor with reinforcing rings for improved ruggedness, reducing noise and vibration.

All of our liquid ring pumps handle wet or dry gases, with high tolerance to liquid carry over. The LR1B Series has an enhanced bearing design enabling reduced internal clearances for improved efficiency. Pumps are available in cast iron and 316 stainless steel construction as standard with other materials and corrosion resistant coatings available.

Features & Benefits

- Optional central partition enabling dual vacuum duty operation
- Variable area discharge port for optimum performance at all inlet pressures
- Flange-mounted casing construction for extra rigidity
- Top and side inlet/outlet flange options for installations with limited headroom
- Packed gland, single and double mechanical seal options

Dimensions

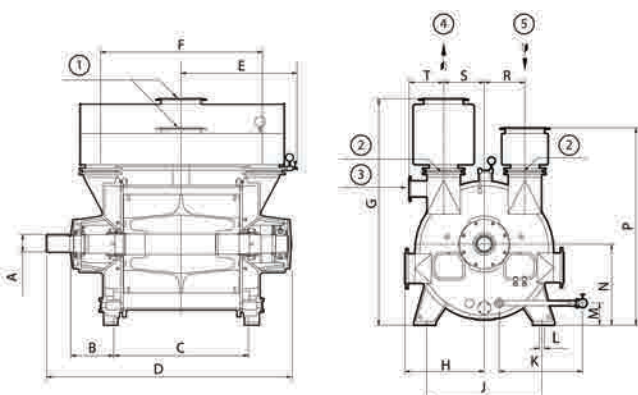

	A (keyway)	B	C	D	E	F	G	H	J
mm	210	450	2020	3185	1600	2280	2965	1025	1600
Inch	8.27	17.72	79.53	125.39	62.99	89.76	116.73	40.35	62.99
	K	M	N	P	R	S	T	L	
mm	1125	290	1120	2560	490	490	370	4 holes Ø 48	
Inch	44.29	11.42	44.09	100.79	19.29	19.29	14.57	1.89	

1. DN500 / PN10 2. DN400 / PN10 3. DN200 / PN10 4. Outlet 5. Inlet
*Flanges available in both DIN and ANSI standards

Applications

- The LR1B22000 is ideal for fly ash conveying, pulp and paper, filtration, flue gas desulphurization, methane extraction in mining and chemical and petrochemical applications.

Performance Curves

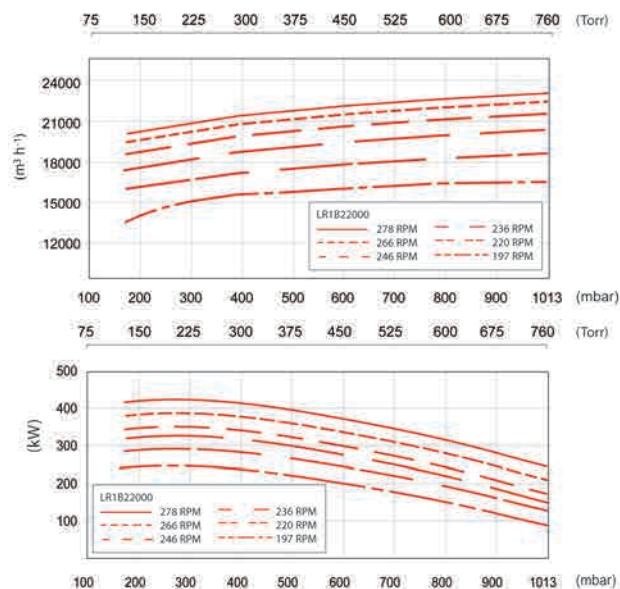

Technical Data

	50 Hz / 60 Hz
Nominal capacity (saturated)	22800 m ³ h ⁻¹ 13400 CFM
Suction pressure	160 mbar 120 Torr
Nominal speed	276 rpm
Nominal motor power	500 kW 650 HP

Ordering Information

Product Description	Order No.
LR1B22000 Liquid Ring Pump	LR1B22000

LR1B30000 Liquid Ring Pump

Edwards offers a full range of liquid ring pumps. The LR1B30000 provides a single-stage design and curved blade impellor with reinforcing rings for improved ruggedness, reducing noise and vibration.

All of our liquid ring pumps handle wet or dry gases, with high tolerance to liquid carry over. The LR1B Series has an enhanced bearing design enabling reduced internal clearances for improved efficiency. Pumps are available in cast iron and 316 stainless steel construction as standard with other materials and corrosion resistant coatings available.



Features & Benefits

- Optional central partition enabling dual vacuum duty operation
- Variable area discharge port for optimum performance at all inlet pressures
- Flange-mounted casing construction for extra rigidity
- Top and side inlet/outlet flange options for installations with limited headroom
- Packed gland, single and double mechanical seal options

Applications

- The LR1B30000 is ideal for fly ash conveying, pulp and paper, filtration, flue gas desulphurization, methane extraction in mining and chemical and petrochemical applications.

Dimensions

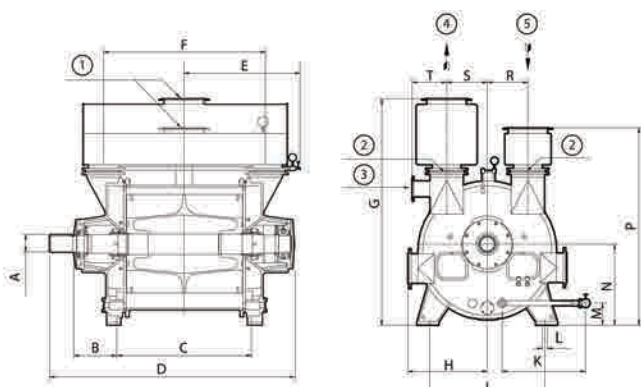

A (keyway)	B	C	D	E	F	G	H	J
mm	210	450	2280	3445	2540	2965	1025	1600
Inch	8.27	17.72	89.76	135.63	100.00	116.73	40.35	62.99
K	M	N	P	R	S	T	L	
mm	1125	290	1120	2560	490	490	370	4 holes Ø 48
Inch	44.29	11.42	44.09	100.79	19.29	19.29	14.57	1.89

1. DN500 / PN10 2. DN400 / PN10 3. DN200 / PN10 4. Outlet 5. Inlet
*Flanges available in both DIN and ANSI standards

Performance Curves

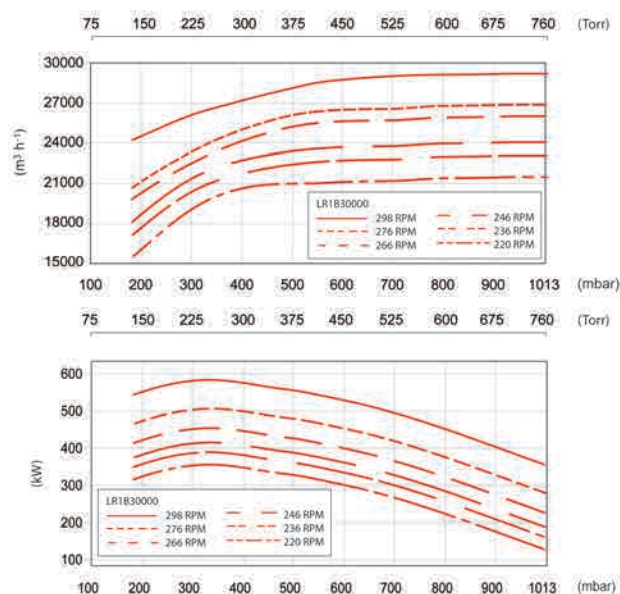

Technical Data

	50 Hz / 60 Hz
Nominal capacity (saturated)	30000 m ³ h ⁻¹ 17600 CFM
Suction pressure	160 mbar 120 Torr
Nominal speed	312 rpm
Nominal motor power	560 kW 750 HP

Ordering Information

Product Description	Order No.
LR1B30000 Liquid Ring Pump	LR1B30000

LR1B38000 Liquid Ring Pump



Edwards offers a full range of liquid ring pumps. The LR1B38000 provides a single-stage design and curved blade impellor with reinforcing rings for improved ruggedness, reducing noise and vibration.

All of our liquid ring pumps handle wet or dry gases, with high tolerance to liquid carry over. The LR1B Series has an enhanced bearing design enabling reduced internal clearances for improved efficiency. Pumps are available in cast iron and 316 stainless steel construction as standard with other materials and corrosion resistant coatings available.

Features & Benefits

- Optional central partition enabling dual vacuum duty operation
- Variable area discharge port for optimum performance at all inlet pressures
- Flange-mounted casing construction for extra rigidity
- Top and side inlet/outlet flange options for installations with limited headroom
- Packed gland, single and double mechanical seal options

Dimensions

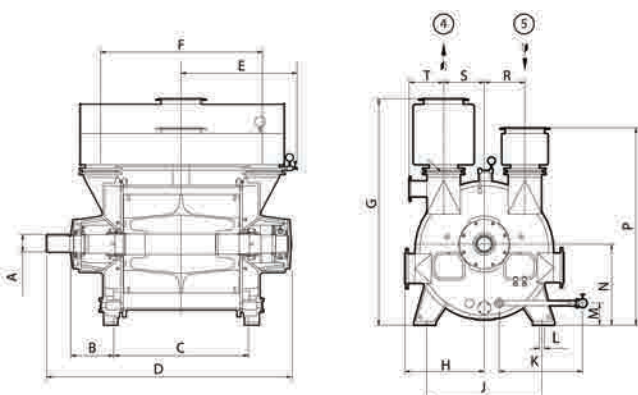

	A (keyway)	B	C	D	E	F	G	H	J
mm	200	450	2490	3655	1730	2540	2965	1900	1600
Inch	7.87	17.72	98.03	143.90	68.11	100.00	116.73	74.80	62.99
	K	M	N	P	R	S	T	L	
mm	1155	290	1120	2560	490	490	370	4 holes Ø 48	
Inch	45.47	11.42	44.10	100.79	19.29	19.29	14.57	1.89	

4, Outlet 5, Inlet
*Flanges available in both DIN and ANSI standards

Applications

- The LR1B38000 is ideal for fly ash conveying, pulp and paper, filtration, flue gas desulphurization, methane extraction in mining and chemical and petrochemical applications.

Performance Curves

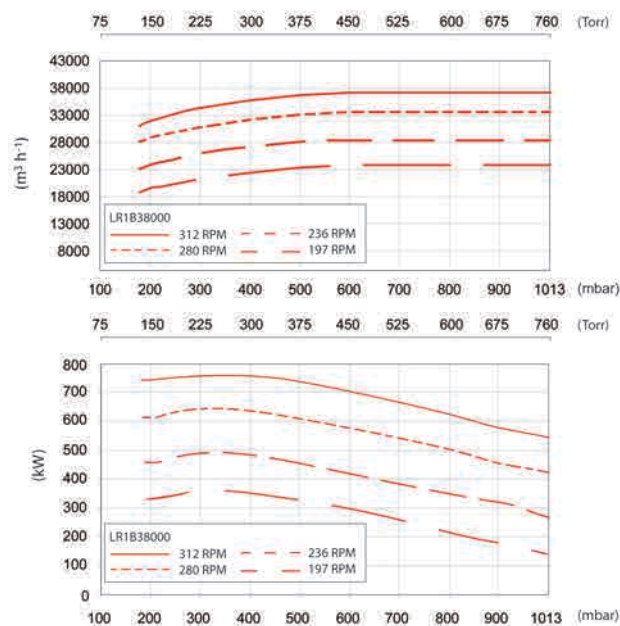

Technical Data

	50 Hz / 60 Hz
Nominal capacity (saturated)	37500 m ³ h ⁻¹ 22000 CFM
Suction pressure	180 mbar 135 Torr
Nominal speed	312 rpm
Nominal motor power	775 kW 1000 HP

Ordering Information

Product Description	Order No.
LR1B38000 Liquid Ring Pump	LR1B38000

Shelf Dryers

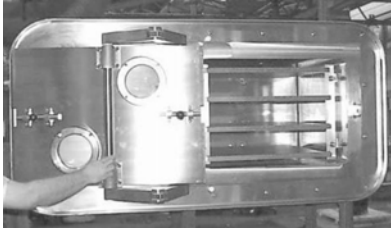

Stokes Vacuum Shelf Dryers Model 438

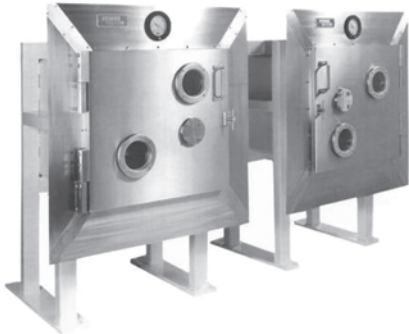

Stokes Model 438 vacuum shelf dryer

Edwards has over 90 years experience in the design of dryers for the chemical, pharmaceutical, plastics and metallurgical industries and has pioneered the design of heated shelves for vacuum shelf dryers.

Stokes Model 438 Shelf Dryers

Edwards Shelf Dryers provide rapid drying of heat sensitive, air sensitive, pyrophoric, and other materials that require drying without agitation. The dryer chamber features heated shelves (see below) which are sealed by use of an O-ring contained in a machined groove in the chamber door. The chamber assembly includes a vacuum break valve, vacuum gauge, a drain connection, and a connection for product thermocouples, and can be fitted with other connections as needed.

Stokes Model 438 Heated Shelf Design



One of the key design features of the Stokes Shelf Dryer is the shelf heating connection and manifold system. The supply and return tube for each shelf protrude through the back wall of the chamber where they connect to the supply and return header. Where each shelf exits the chamber, the tube is sealed with a proprietary tube ferrule sealing the chamber and assuring the vacuum integrity of the chamber. All shelf manifold connections are located outside of the drying chamber, eliminating any possible contamination of the product from leaks in the heating manifold.

An uppermost non-usable shelf is installed serving as the heating surface for the top of the chamber assembly. The shelves are constructed and inspected for maximum steam working pressure of 50 psig and are suitably baffled for efficient heating or cooling using water, oil, or steam.

Stokes Model 438 Specifications

- Non-code chamber as standard
- Heated shelves, 50 psi design pressure
- External manifolded shelf heating connections
- Door hinged with Viton® O-ring seal and clamps
- Sight glasses through door
- Vacuum gauge & 4 psi vacuum break valve
- Sloped bottom for draining, includes 1 inch NPT manual drain valve

Options

- Carbon steel, 316LSS, or other special materials upon request
- Internal finishes: Mill finish, #4 polish, or other coating options available upon request
- Wall flange
- Upgraded elastomers
- Washdown duty
- Instrumentation
- Additional connections
- Door validation port
- Vacuum port location
- Vacuum System
- Heating System
- CE Marking not available at this time
- Other options available upon request

Glovebox Vacuum Shelf Dryers Model 438GBX

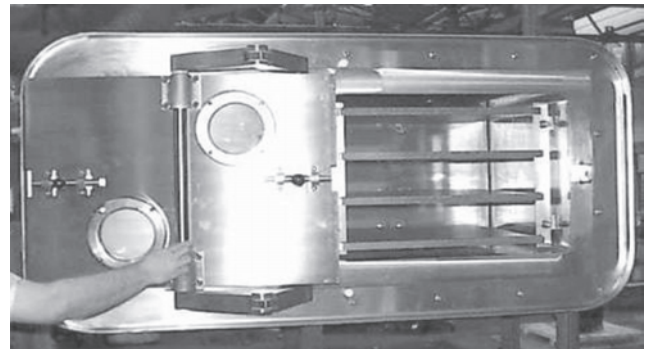

438GBX available in sizes B, D and F only.

Edwards offers a "GBX" series vacuum shelf dryer to provide an air/liquid tight seal when mating to an isolation glove box. This design includes a spigot to accept an inflatable gasket seal from a portable glove box. The spigot is sealed to the chamber with a silicone gasket to ensure full isolation. The door hinges are a double articulating davited type design to keep the door swing within the parameters of the glove box.

Data Summary Stokes Vacuum Shelf Dryers Model 438

Chamber Size

Chamber Size b				Chamber Size d				Chamber Size f				Chamber Size h				Chamber Size j			
#	A	C	W	#	A	C	W	#	A	C	W	#	A	C	W	#	A	C	W
B-0	0.0	20.5	700	D-0	0.0	27.0	970	F-0	0.0	39.0	1600	H-0	0.0	49.0	3530	J-0	0.0	71.5	4200
B-1	4.0	16.3	920	D-1	6.0	23.0	1270	F-1	6.0	35.0	1920	H-1	12.2	44.0	4170	J-1	12.2	65.0	4840
B-2	8.0	7.6	1030	D-2	12.0	11.0	1420	F-2	12.0	17.0	2080	H-2	24.4	21.5	4490	J-2	24.4	32.0	5160
B-3	12.0	4.8	1140	D-3	18.0	7.0	1570	F-3	18.0	11.0	2240	H-3	36.7	14.0	4810	J-3	36.7	21.0	5480
B-4	16.0	3.3	1250	D-4	24.0	5.0	1720	F-4	24.0	8.0	2400	H-4	48.9	10.3	5130	J-4	48.9	15.5	5800
B-5	20.0	2.5	1360	D-5	30.0	3.8	1870	F-5	30.0	6.2	2560	H-5	61.1	8.0	5450	J-5	61.1	12.2	6120
B-6	24.0	1.9	1470	D-6	36.0	3.0	2020	F-6	36.0	5.0	2720	H-6	73.3	6.5	5770	J-6	73.3	10.0	6440
				D-7	42.0	2.4	2170	F-7	42.0	4.1	2880	H-7	85.6	5.4	6090	J-7	85.6	8.4	6760
				D-8	48.0	2.0	2320	F-8	48.0	3.5	3040	H-8	97.8	4.6	6410	J-8	97.8	7.2	7080
				D-9	54.0	1.7	2470	F-9	54.0	3.0	3200	H-9	110.0	4.0	6730	J-9	110.0	6.3	7400
								F-10	60.0	2.6	3360	H-10	122.2	3.5	7050	J-10	122.2	5.6	7720
								F-11	66.0	2.3	3520	H-11	134.4	3.1	7370	J-11	134.4	5.0	8040
								F-12	72.0	2.0	3680	H-12	146.7	2.8	7690	J-12	146.7	4.5	8360
												H-13	158.9	2.5	8010	J-13	158.9	4.0	8680
												H-14	171.1	2.2	8330	J-14	171.1	3.7	9000
												H-15	183.3	2.0	8650	J-15	183.3	3.4	9320
																J-16	195.6	3.1	9640
																J-17	207.8	2.8	9960
																J-18	220.0	2.6	10280
																J-19	232.2	2.4	10600
																J-20	244.4	2.3	10920
																J-21	256.7	2.1	11240
																J-22	268.9	2.0	11560

A Useable total surface area (sq. ft.)
 C Clearance between shelves (inches)
 W Weight (lbs)

Dimensions and Shelf Information

Chamber Size	Overall Dimensions			Internal Dimensions			Shelf Information		
	Width	Depth (Door Open)	Height	Width	Depth	Height	Volume (ft ³)	Size Each	Useable Shelves
438 B	40.5"	75"	56"	30"	29"	20.5"	10.3	24" x 24"	up to 6
438 D	40.5"	77"	66"	30"	42"	27"	19.7	24" x 36"	up to 9
438 F	40.5"	85.5"	75"	30"	42"	39"	28.4	24" x 36"	up to 12
438 H	62"	107"	77.5"	50"	46"	49"	65.2	44" x 40"	up to 15
438 J	66"	110"	99"	50"	46"	71.5"	95.2	44" x 40"	up to 22



Steam Ejector Vacuum Systems

Edwards has over 90 years experience in the design and supply of steam ejector systems. Edwards has been instrumental in the development of the steam ejector from the relatively crude single stage devices which evolved into today's highly efficient multi-stage systems.

Process and mechanical design expertise is combined with project management skills for the supply of individual items of plant, or the execution of total projects including installation and commissioning. The company has an immense reputation in applications including the following:

- Refinery Vacuum Systems
- Vacuum Distillation Units
- Flash Evaporation for Seawater Desalination
- Turbine Condenser Air Extraction
- Edible Oil Processing
- Polymerization
- Crystallization
- Evaporative Cooling

Features of the Steam Ejector Solution

- Low capital cost
- No moving parts
- Low maintenance
- Wide choice of materials
- No close clearances
- No size limitation
- Ability to handle large vapour load
- Liquid slugs do not cause mechanical damage
- Not sensitive to suction temperature

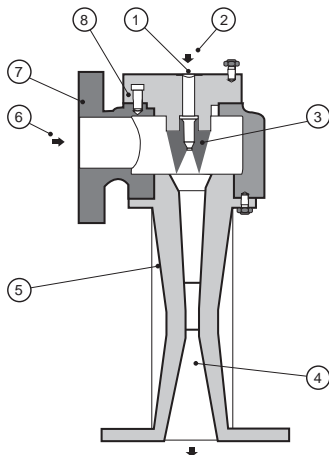

- | | |
|----------------|-----------------|
| 1 Strainer | 5 Diffuser |
| 2 Motive steam | 6 Suction |
| 3 Nozzle | 7 vapour Head |
| 4 Discharge | 8 Nozzle Holder |

Range

Ejectors can be arranged as multi-stage systems with interstage condensers, which may be the direct contact type (jet condenser) or surface type (shell and tube). The multi-stage arrangements allows lower suction pressures to be achieved than could be produced by a single stage ejector. Interstage condensers economize on the use of motive steam, since the operating steam from stages upstream of the condenser is condensed leaving only saturated incondensable gases to be handled by the succeeding stage or stages.



Operating Pressure

Single Stage	150 – 130 mbar
Two Stage	25 – 15 mbar
Three Stage	10 – 7 mbar
Four Stage	1 mbar
Five Stage	0.1 mbar

As ejectors can be economically manufactured on an individual basis to suit specific customer needs they have a wide capacity range, which is limited only by the manufacturing techniques relevant to the material of construction, typically this range would be between $10 - 1.5 \times 10^6 \text{ m}^3\text{h}^{-1}$.

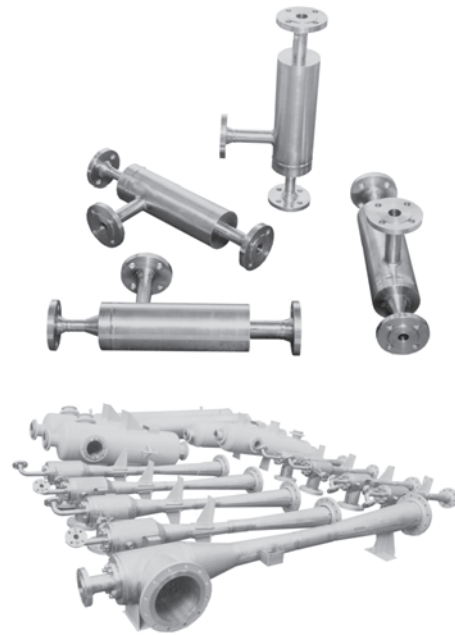

Interstage Jet Condensers

Jet or spray type condensers operate by condensing steam by direct contact with the cooling water. This type of condenser can be located at barometric height or at low level using a condensate extraction pump. Jet condensers tend to use less cooling water than surface types, although as the ejected vapours are in contact with the cooling water the treatment of any resulting effluent must be considered.

Interstage Surface Condensers

Surface condensers of the shell and tube type perform the same function as jet types, however the ejector steam and process vapours are condensed on the tube surfaces without contact with the cooling water, greatly reducing the potential effluent problem. Removable end covers on the condensers allow easy cleaning of the tubes.

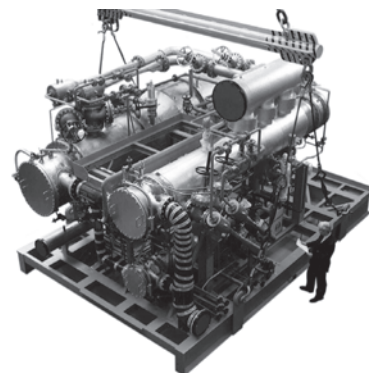

Deaeration Equipment

Multistage Ejector/Liquid Ring Pump Combinations

Edwards are able to offer combinations of steam ejectors and liquid ring pumps where the liquid ring pump replaces the final stage or stages of a steam ejector system.

This enables large vapour/gas flows to be handled at the low pressures associated with multi-stage steam ejector sets whilst substantially reducing steam consumption and hence operating costs.

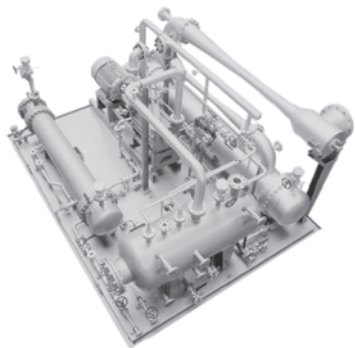

Ejector and ejector liquid ring pump combinations can be supplied using Edwards designed liquid ring pumps. The depth of experience in both types of equipment allows optimisation of the equipment both in performance and economy of utilities.

Applications and Design Services

Edwards offers a comprehensive design service based on unrivalled process vacuum experience, application knowledge and design capabilities.

In order to propose a solution the following information is required at the enquiry stage:

- Suction flow
- Composition and Molecular weight
- Suction pressure
- Discharge temperature
- System volume
- Evacuation time
- Discharge pressure
- Motive pressure and temperature, max-normal-min
- Cooling water temperature, max-normal-min
- Type of condenser direct or indirect
- Type of installation Barometric or low level
- Materials of construction
- Design codes applicable

Edwards experience in water deaeration equipment spans more than 70 years, serving essentially two markets and applications:

Seawater deaerators for water injection systems for secondary recovery of oil from offshore reservoirs

Boiler feedwater and process deaeration for power generation plants, boilers and process use

Seawater Deaerators

Secondary recovery by means of water injection is frequently an essential feature of crude oil production. It is often a crucial factor in achieving and sustaining economically viable production rates.

The source of the water is dependant on the location of the production facility and could be from a subsurface source such as produced water or an aquifer, or from a surface source such as the sea or a river.

The latter two sources, as with most surface waters, normally contain substantial levels of dissolved oxygen. In order to control corrosion rates in downstream plant and to inhibit bacterial growth this oxygen must be removed before the water is used for injection.

Edwards is able to provide extensively proven deaeration technology to facilitate the removal of this oxygen to levels such that the remaining residual may be economically removed by the addition of a chemical scavenger.

The following options are available:

- Spray/pack deaerators
- Packed column deaerators
- Trace gas stripping deaerators

Spray/pack Deaerators

Although conventional packed bed deaerators offer a satisfactory solution in many circumstances, the unique Edwards spray packed deaerator technology offers significant advantages over conventional designs. It affords additional benefits for FPSO installations because the mass transfer efficiency of the spray section is unaffected by wave motion and by any foaming of the water as it enters the deaerator.

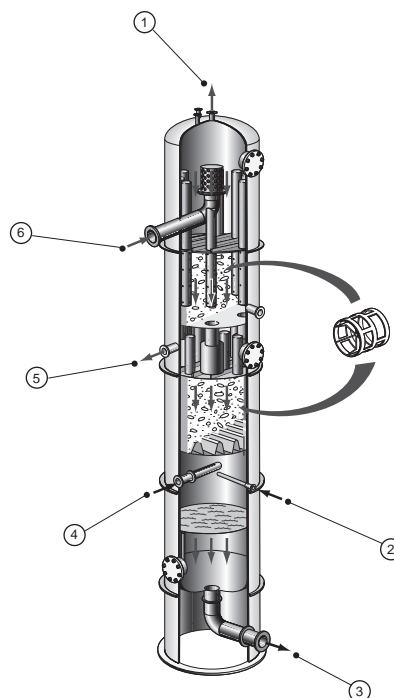

- | | |
|-------------------------------|--------------------------------|
| 1 First stage vapour take-off | 4 Recycle |
| 2 Oxygen scavenger | 5 Second stage vapour take-off |
| 3 Water outlet | 6 Water inlet |

This patented design offers many benefits over conventional deaerators and compact deaerator designs including the following:

- Substantial height and weight reduction compared to conventional vacuum stripping columns
- May be used upstream of sulphate reduction membranes, since it can operate without the addition of anti-foam chemicals
- Unaffected by any motion of the installation, making it the preferred technology for FPSO applications
- There is no reliance on catalysts, which have a limited life span and may be poisoned
- There is no requirement for storage and/or production of hazardous combustible products such as methanol or hydrogen
- Extensively field-proven technology, with over 50 units utilising the spray distributor supplied for water injection service

Packed Column Deaerators

This conventional design uses well-proven technology and remains the industry standard for both onshore and offshore applications worldwide.



The design is suitable for both vacuum and gas stripping applications with corrosion resistant tower internals designed for foam retention, efficient liquid and gas phase distribution and redistribution, in order to maximise mass transfer efficiency.

Trace Gas Stripping Deaerators

This patented system combines vacuum stripping and inert gas stripping to offer a unit that operates under vacuum with the mass transfer process being assisted by a small quantity of inert gas admitted into the deaerator column.

This process allows highly compact deaerator columns to be used whilst the required vacuum pump capacity is substantially lower than would be associated with conventional vacuum stripping deaerators.

Deaeration and the use of Sulphate Removal Systems

Edwards is able to offer field proven designs for water injection deaerators, which are required to operate upstream of sulphate removal systems. Such installations require that the deaerator must operate without antifoam agents since the use of such agents in incompatible with the membranes used in the sulphate removal system.

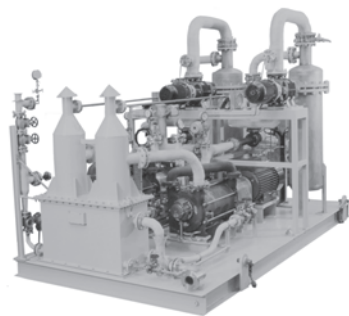

Edwards has supplied units to replace conventional packed column deaerator designs supplied by other manufacturers that have proved to be incapable of operating at the required design conditions without the use of antifoam agents. Our ability to offer proven technologies, which provide enhanced mass transfer capability can enable existing deaerator vessels to be re-used in order to minimise the cost and downtime associated with the upgrade.

Sulphate removal systems may be installed upstream of the deaerator in which case antifoam agents may be used, however this location upstream of the deaerator column has many serious disadvantages, which include:

- Materials of construction of the sulphate removal system must be suitable for service in contact with undeaerated seawater
- Presence of oxygen in the seawater will increase the risk of oxidation of the membranes and/or the possibility of aerobic bacteria or algae growth on the membranes
- Additional precautions to ensure the removal of any hydrocarbons present in the water may be necessary prior to the sulphate removal system to ensure that these do not contact the membranes

Deaeration on Floating Production Vessels

Edwards has considerable experience in the supply of deaeration packages for use on floating production vessels, including installations on FPSO's, semi-submersibles and on tension leg platforms.

These production facilities require that the deaeration package is insensitive to the motion of the installation and that the height and weight of the package together with the elevation of the center of gravity above grade level are minimised.

Our deaeration technology includes designs that are ideally suited to such floating production facilities, with references available for these types of installations at locations around the world, in conditions ranging from offshore Canada to Equatorial Africa.

Boiler Feedwater and Process Water Deaerators

The types of deaerator described have been developed over years of experience of the different types required for numerous industrial applications. Examples of some of the industries where deaeration is used are:

Power Stations – treating boiler feed water.

Oil Refineries and Chemical Plants – treating boiler feed water and process deaeration.

Breweries – deaerating water in the production of high gravity beer.

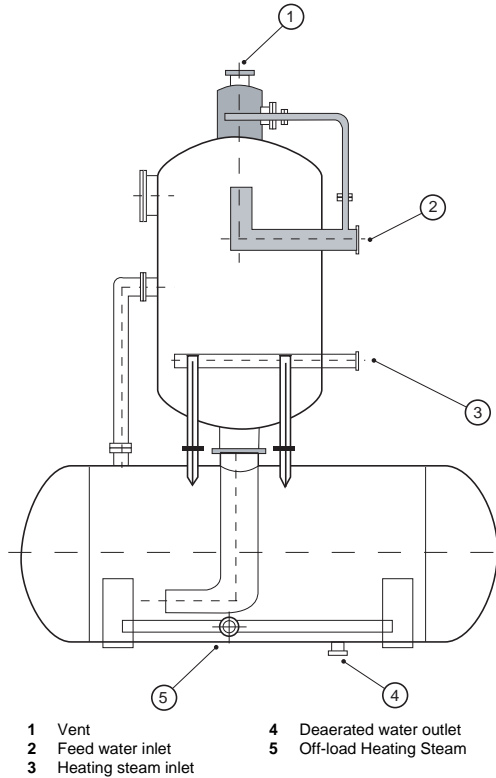

- | | |
|-----------------------|--------------------------|
| 1 Vent | 4 Deaerated water outlet |
| 2 Feed water inlet | 5 Off-load Heating Steam |
| 3 Heating steam inlet | |

High Level Pressure Deaerators

For modern industrial installations where heat economy is essential, and where even lower oxygen contents are demanded to avoid costly maintenance work, the pressure heater/deaerator system is used where inlet boiler feed water is heated to well above atmospheric boiling point.

Edwards has developed a system of sprays and trays such that the feed water enters the deaerator through an atomizing spray valve assembly into the upper volume of the deaerator vessel where primary deaeration takes place. The feed then falls over a series of trays to the base of the deaerator during the course of which secondary deaeration takes place.

Heating steam is admitted via a diffuser positioned below the tray assembly to ensure ultimate heating effect and optimum scrubbing action so as to produce residual oxygen contents down to 0.007 p.p.m. or less. This deaerating section is mounted on a storage compartment such that the whole system can be mounted at a suitable height to obtain the required suction head on the boiler feed pump advised by the manufacturer.

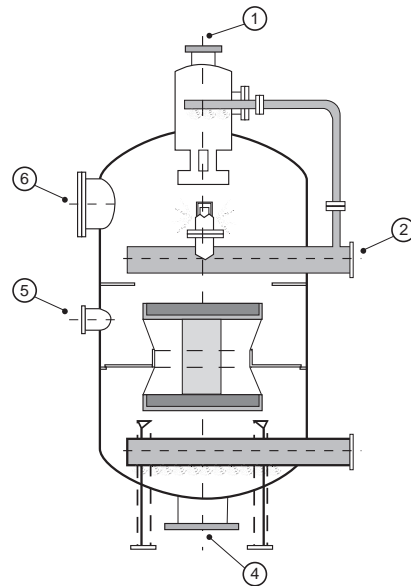

- | | |
|-----------------------|-------------------------------|
| 1 Vent | 4 Discharge to storage vessel |
| 2 Feed water inlet | 5 Balance pipe return |
| 3 Heating steam inlet | 6 Manway |



Guide to Pump Selection and Pipe Installation	463
Conversions	466
Material Safety Data Sheets	467

EXPERT ADVANTAGE

Our Expertise Your Advantage

Our Expertise is in understanding how to get the most from your Edwards product, using the know-how we have gathered from supporting our global installed base of over 750 000 Edwards Vacuum Pumps and 8 500 Edwards Exhaust Management Systems.

Your Advantage is in being able to optimise your total cost of ownership (TCO), to improve product and process yield, and to minimise your environmental impact. Whether the repair of a single unit, or a proactive programme of managing and optimising all Edwards product across your facility, Expert Advantage offers a choice for you.

- Product upgrades and optimisation
- Product repair and overhaul
- Product exchange
- Replacement parts, kits and tooling
- On-site support
- Service contracts and agreements
- Operation, maintenance and service training
- Certified product sales

Upgrades and Optimisation

Take advantage of Edwards' latest technology and know-how by upgrading or optimising your existing equipment. We offer cost effective upgrade of most Edwards and other branded equipment, allowing you to benefit from enhanced performance, energy efficiency, and greatly improved cost of ownership. Through CIP driven optimisation programmes, we use our know-how developed from our global installed base to help you enhance your process and product yield, and realise Total Cost of Ownership (TCO) improvements.

- Innovative products and upgrades to reduce carbon footprint and optimise environmental strategy
- Simple single equipment retrofit kits to full facility-wide turnkey programmes with high return on investment
- Technology upgrades, system tuning and optimisation for product and process yield improvements
- Sophisticated modelling and simulation, validated against our global knowledge base
- Remote diagnostics and prognostic condition monitoring with FabWorks-iMS for TCO optimisation

Product Repair and Overhaul

When products require more than just routine maintenance and you want the confidence afforded by the quality and standard of repair only the OEM can guarantee, then choose from our range of product repair and overhaul services. Edwards offers fixed price servicing for swift response and simple budgeting, or a flexible pricing structure for maximum cost control.



Highly trained service technicians follow factory derived procedures in all our facilities globally.

Product Exchange

If process uptime is critical, or it is simply not convenient to perform repair or maintenance work on site, the Edwards Service Exchange Programme offers rapid product replacement from a comprehensive global inventory (for common pump variants and subject to availability). Products are rebuilt and tested to factory derived standards by factory trained technicians and are backed up by a comprehensive 1 year warranty.

Replacement Parts, Kits and Tooling

Genuine Edwards Replacement Parts are produced to the same quality standards as our new products. They always meet the latest product standards and will minimise your maintenance time by helping you get the job done right the first time.

To simplify your job we offer many kits/sets tailored to your Edwards product needs for periodic and repair maintenance. Use Genuine Edwards Replacement Parts kits and your maintenance team will start work with the materials they need to get the job done: save time, reduce your supply chain cost, extend the life of your product and enjoy years of trouble free operation.

With distribution centres globally located, Edwards can meet your needs for availability of our Genuine Replacement Parts.



Edwards' service facility in Brno, CZ, part of our global network

Certified Products

Edwards Certified Products are pre-owned units, refurbished in our OEM remanufacturing factories by our skilled technicians using genuine Edwards' spare parts only. Certified products offer a cost effective and carbon friendly option to acquire additional vacuum and abatement equipment.

Certified products are provided with all the accessories required to install your product straight out of the box, typical installation accessories include electrical connectors, water connectors, inlet and exhaust o-rings as well as full instructions for installation and usage.

Edwards Certified Products are available globally through our extensive service and logistics Network. Due to the rapidly changing nature of the used equipment market please contact Edwards in the first instance to ensure product availability before ordering.

Onsite Services

Highly skilled Edwards teams, supporting End-users, OEMs and Systems Integrators alike worldwide, work in partnership with you, at your site. From simple single visits to integrated multi-site teams, resolving breakdowns, providing continuous improvement, optimising equipment uptime and yield, and reducing your site management costs. Options include:

- Product installation and commissioning, operator training
- Scheduled monitoring, preventative and predictive maintenance, breakdown support
- Upgrades providing improved performance and efficiency
- Logistics management to optimise availability and supply chain
- Emergency hotline and service support, including availability outside of normal working hours
- Local, regional and global agreements, flexible and integrated with your support network



Service Contracts and Agreements

Tailored Contracts, ideal for larger installations, bring together any combination of our service product range into one package, whether for a single turnkey activity or longer term equipment maintenance, management and optimisation programmes focussed on reducing total cost of ownership.

For smaller installations, or those under the cost control of multiple managers, Edwards provides standard fixed price contracts for simple budgeting and cost management.



Edwards support extends across our complete range of products.

Operation, Maintenance and Service Training

Avoid unplanned downtime with correct operation and maintenance by taking advantage of professional advice over the phone, or dedicated onsite training for your technicians and operators.

Local Support from a Global Company

We understand the importance of local support. Edwards has a number of major service facilities located throughout the world, backed up by an extensive team of engineers and technicians to provide the support you need. From Edwards you can expect a local, rapid response and great value service, delivered by the experts.

Consistent and Reliable Standards Wherever You Are

We develop or manufacture the training, processes, tooling and parts used throughout our service network at the factories where we develop and manufacture our products. This is why our service team is always ready to deliver quality support. As you would expect from a responsible, global company, we operate under ISO9001 and ISO14001 accreditation.

EXPERT ADVANTAGE
Our Expertise Your Advantage

Global Support from Edwards

Our worldwide network of around 1000 service personnel is easily and simply accessed through your local Edwards Office.

Global Support from Edwards



www.edwardsvacuum.com/service

Location	Contact Telephone Number	Contact Email
United Kingdom	+44 (0)1293 842202	Aftersales@edwardsvacuum.com
Ireland		
Benelux		
Austria		
Switzerland		
Poland		
Czech Republic		
Russia		
Eastern Europe		
Middle East		
South Africa		
Germany	+49 (0)800 000 1457	DEservice@edwardsvacuum.com
Italy	+39 (0)863 509516	ITmanutenzione@edwardsvacuum.com
France, North Africa	+33 (0) 1 47 98 24 01	FRserviceapresvente@edwardsvacuum.com
Israel	+(972) 7 681 0633	Edwards.israel@edwardsvacuum.com
Americas (except Brazil)	+(1) 1 800 848 9800	edwardsstokesservice@edwardsvacuum.com
Brazil	+ 55 11 3952 5000	service@edwardsvacuum.com.br
SE Asia, Australasia	+(65) 6546 8408	Customer.careSG@edwardsvacuum.com
Korea	+(82) 41 621 7070	infokorea@edwardsvacuum.com
Taiwan ROC	+886-37-581000	Customer.CareTW@edwardsvacuum.com
Peoples Republic of China and SAR	+(86) 21 5866 9618 x25	CareSHA.Customer@edwardsvacuum.com
Japan	+81-47-458-8853	edj.service@edwardsvacuum.com
India	+91-20-40752210	India@edwardsvacuum.com

Guide to Pump Selection and Pipe Installation

Our experienced applications team are trained to provide expert advice on specifying the correct pumping system. Please contact your local Edwards office for further details.

Rotary Pump Speed and Pump-Down Time Calculations

To estimate the pump speed you need to reach a given system pressure, P:

$$S = (F \times V)/t \quad (1)$$

To estimate the time to pump-down your system to a given pressure, P:

$$t = (F \times V)/S \quad (2)$$

where t is the pump-down time

F is the pump-down factor at pressure P

V is the volume of the vacuum system

S is the speed of the rotary pump

Read F from Figure 1. t , V and S must be in consistent units: for example, t in hours, V in cubic metres (m^3) and S in cubic metres per hour (m^3h^{-1}).

Speed and Power Curves

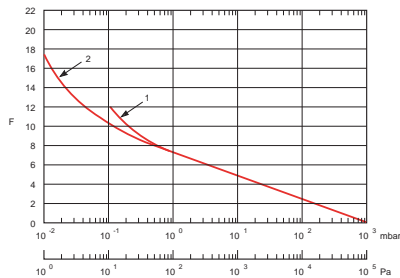

- 1 One-stage rotary pump
- 2 Two-stage rotary pump or pump combination

Figure 1 – Pump-down factor, F , as a function of system pressure, mbar

F applies a correction for the change in the speed of rotary pumps as the inlet pressure decreases. But F does not include a correction for the effect of conductance of inter-connecting pipes (refer to the section below if you want to apply this correction).

These calculations apply to clean and leak tight vacuum systems. It is difficult to extend these curves to below 0.1 mbar, because the effect of system design and out-gassing become increasingly important at lower pressures.

For example, you have a $0.06 m^3$ (60 l) vacuum system that you must evacuate to 1 mbar in 0.05 hr (3 minutes). From Figure 1, at 1 mbar $F = 7$.

$$S = (F \times V)/t = (7 \times 0.06)/0.05 = 8.4 m^3h^{-1}$$

So, you require a pump with a minimum speed of $8.4 m^3h^{-1}$ and an ultimate vacuum well below 1 mbar. Edwards RV8 pump is suitable for this application.

Effect of the Conductance of Connection Pipes

Resistance to flow of gases and vapours through pipes can significantly affect the size of pump you require or the pump-down time you can achieve with a given pump. If you know the dimensions of the pipes in your system, you can correct the speed and pump-down time calculations. The conductance of 1 m lengths of pipes of various diameters is shown in Figure 2.

Please note these limitations for the data in this graph. The data shown in the dotted portions of the curves applies only to low velocity, viscous, laminar flow in long pipes (where the length of the pipe is typically many 100 times the pipe diameter). This data does not apply to turbulent flow (when the pipe conductance may be significantly reduced) or to compressed gases (such as gases in short pipes or subject to high speed flows). If your calculations are for short pipes (where the length of the pipe is typically < 100 times the pipe diameter), or for pipe diameters and pressures shown by the dotted portions of the curves in Figure 2, please refer to Wutz¹ or Dushman², or contact Edwards for advice.

Speed and Power Curves

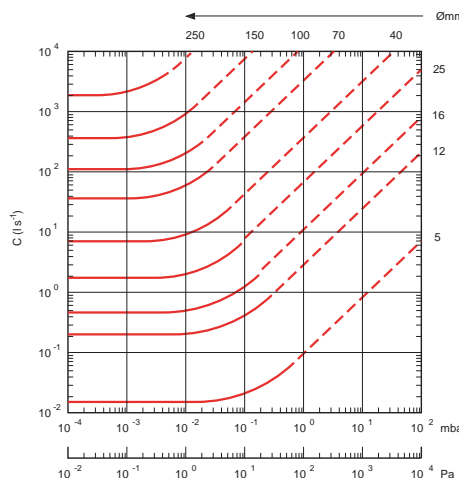

Figure 2 – Conductance of 1 m of round pipe, for air at 20 °C (the data shown in the dotted portions of the curves is for low velocity, viscous, laminar flow in long pipes)

The conductance of a pipe at a given pressure is:

$$C_p = C/l$$

where C_p is the conductance of the pipe

C is the conductance per metre, read from Figure 2

l is the length of the pipe in metres.

Then, you can use the value for C_p to correct the pumping speed at the end of the pipe when it is connected to the pump inlet; use this equation:

$$1/S_p = (1/S) + (1/C_p) \text{ or } S_p = (C_p \times S)/(C_p + S) \quad (3)$$

where S_p is the pumping speed at the end of the pipe

S is the speed of the pump.

Use a similar procedure to make an approximate correction to the pump-down time calculation. First, read the value of C at the required system pressure from Figure 2, and calculate C_p for your pipe at that pressure. Then use the pump speed, S , and C_p in equation (3) to calculate the corrected speed, S_p . Use this value of S_p in equation (2) to estimate the pump-down time, t .

If you use a narrow pipe between the pump and the process chamber, this restricts the effective pumping speed. It is usually more economical to use a wider or shorter pipe and a smaller pump, than to restrict the pumping speed of a larger pump. You should aim at the effective pumping speed to be 80% or more of the pump's speed. You can use equation (3) and the graph in Figure 2 to select the minimum size of the pipe you need.

For example, you need a pumping speed of $150 m^3h^{-1}$ at 1.0 mbar in your process chamber, and the pump must be 6 m away from the chamber. The E2M175 ($135 m^3h^{-1}$ at 1 mbar) is too small for this application, even without losses in the pipelines. So, consider the E2M275 pump which has a pump speed of $230 m^3h^{-1}$. Use equation (3) to calculate the minimum conductance of the connecting pipe:

$$C_p = (S \times S_p)/(S - S_p) = (230 \times 150)/(230 - 150) = 430 m^3h^{-1}$$

The conductance per metre is then $430 \times 6 = 2580 m^3h^{-1}$. In Figure 2, the nearest larger diameter pipe that has a conductance of $2580 m^3h^{-1}$ or more at 1.0 mbar is 70 mm. Conveniently, this is the same diameter as the inlet of the E2M275 pump.

1 *Theory and Practice of Vacuum Technology*, M Wutz, A Herman, and W Walcher, Friedr. Vieweg and Sohn, (1989)

2 *Scientific Foundations of Vacuum Technique*, 3rd ed, S Dushman and J Lafferty, Wiley (1997)

Maximum Pipe Length for Increase in Pump-Down Time of < 20%

Table 1 gives a quick guide to the maximum length of pipe you can use to connect the pump to your vacuum system, if you want the conductance of the pipe to contribute no more than 20% to the pump-down time.

Pump Model	Pump Inlet	Inlet Ø (mm)	Maximum Pipe Length (m), for Pump-Down to			
			1 mbar		0.1 mbar	
			50 Hz	60 Hz	50 Hz	60 Hz
Speedivac 2	¼ inch BSP	12	4	3.5	–	–
E2M0.7	NW10	10	6	5	0.7	0.6
E2M1, E2M1.5	NW10	10	3	2.5	0.3	0.3
RV3	NW25	25	50	45	7	6
RV5	NW25	25	35	30	4.5	3.5
RV8	NW25	25	22	19	3	2
RV12	NW25	25	16	14	2	1.5
E1M18, E2M18	NW25	25	11	9	1.5	1
E2M28	NW25	25	8	6.5	1	0.8
E2M40	ISO40	40	26	24	2.5	2
E2M80	ISO40	40	16	13	1.5	1
E2M175	ISO63	70	31	28	4	3.5
E2M275	ISO63	70	25	21	3.5	2.5

Table 1 – Maximum pipe lengths, for an increase in pump-down time of < 20%

In our calculations, we assumed that the pipes and fittings used correspond to the size of the inlet port. That is, for example, that NW25 pipes and fittings are used for the RV pumps. If you use smaller pipes and fittings, the pump-down times will be increased significantly.

How to Choose a Rotary Pump to Back a Vapour Pump

We recommend that you use two-stage rotary pumps (such as the RV5 or the E2M18 pumps) to back vapour pumps. When a vapour pump operates at its maximum specified throughput, the backing pressure must not be higher than 0.5 times the critical backing pressure. Note that the maximum throughput of most vapour pumps is calculated at 1×10^{-2} mbar: the maximum throughput of vapour booster pumps is calculated at 1 mbar.

Use this equation to calculate the required rotary pump speed:

$$S \geq t_m / (0.5 \times P_{cb})$$

where S is the speed of the rotary pump

t_m is the maximum throughput of the vapour pump

P_{cb} is the critical backing pressure of the vapour pump.

For example, at 1×10^{-2} mbar and a corresponding speed of 60 l s^{-1} , the maximum throughput of the Diffstak 100/300 pump is $60 \times 10^{-2} = 0.6 \text{ mbar l s}^{-1}$. The critical backing pressure of this pump with Santovac® 5 fluid is 0.6 mbar. So, the required rotary pump speed is:

$$S \geq 0.6 / (0.5 \times 0.6) = 2 \text{ l s}^{-1} \sim 8 \text{ m}^3\text{h}^{-1}$$

The nearest larger, two-stage rotary pump suitable for this application (with no correction for pipe conductance effects) is the RV8. If the maximum throughput for your system is lower than the pump's specified maximum throughput, you may be able to use a smaller rotary pump: please contact Edwards for advice.

You must now check that the rotary pump you have selected can pump-down your vacuum system from atmospheric pressure to the critical backing pressure in an acceptable time. If it cannot, you may need to choose a larger rotary pump.

How to Choose a Rotary Pump to Back a Turbomolecular Pump

We recommend that you use two-stage rotary pumps (such as the RV5 or the E2M18 pumps) or scroll pumps to back turbomolecular pumps. The size of the rotary pump you need depends on the maximum backing pressure and the speed of the turbomolecular pump at your required system pressure:

$$S \geq (S_t \times P) / (0.5 \times P_{mb})$$

where S is the speed of the rotary pump

S_t is the speed of the turbomolecular pump, at your required system pressure P

P_{mb} is the maximum backing pressure of the turbomolecular pump.

For conventional turbomolecular pumps, the maximum backing pressure is typically 0.1 mbar: for compound turbomolecular pumps, it is about 5 mbar.

For example, you require a system pressure of 1×10^{-4} mbar with a conventional 200 l s^{-1} turbomolecular pump. The required rotary pump speed is:

$$S \geq (200 \times 10^{-4}) / (0.5 \times 0.1) = 0.4 \text{ l s}^{-1} \sim 1.44 \text{ m}^3\text{h}^{-1}$$

So, you need a rotary pump with a speed, at 0.1 mbar, of $1.44 \text{ m}^3\text{h}^{-1}$.

The nearest larger, two-stage, rotary pump suitable for this application (with no corrections for pipe conductance affects) is the RV3.

You must now check that the rotary pump you have selected can pump-down your vacuum system from atmospheric pressure to the critical backing pressure in an acceptable time. If it cannot, you may need to choose a larger pump. This is particularly important if you use a compound turbomolecular pump: the higher maximum backing pressure of these pumps mean that you can use a smaller backing pump. Note that, in all applications you will achieve a lower ultimate pressure (lower P) if you use a larger backing pump.

If you want to pump hydrogen or helium, these calculations may not apply: please contact Edwards for advice.

Effect of the Pipe Between the Secondary Pump and the Rotary Pump

As we discussed above, the conductance of the pipe between the rotary pump and the secondary pump can reduce the effective pumping speed. This may mean that the critical backing pressure of the secondary pump is exceeded, even though the unrestricted speed of the rotary pump is adequate.

If you know the bore and length of the pipe between the rotary pump and the secondary pump, you can use equation (3) and the data in Figure 2 to calculate the pumping speed at the end of the pipe. Then, match this corrected speed to the maximum throughput of the secondary pump.

Alternatively, in Table 2, we give a quick guide to the maximum length of pipe you can use between the rotary and secondary pumps, if you want the reduction in pump speed at 0.5 mbar to be no more than 20%. In our calculations, we assumed that the pipes and fittings used correspond to the size of the inlet port. That is, for example, NW25 pipes and fittings are used for the RV pumps. If you use smaller pipes and fittings, you must use shorter pipes.

Pump Model	Pump Inlet	Inlet Ø (mm)	Maximum Pipe Length (m)	
			50 Hz	60 Hz
Speedivac 2	¼ inch BSP	12	0.8	0.8
E2M0.7	NW10	10	0.7	0.7
E2M1, E2M1.5	NW10	10	0.4	0.4
RV3	NW25	25	7	6
RV5	NW25	25	4	3.5
RV8	NW25	25	2.5	2
RV12	NW25	25	1.5	1.5
E1M18, E2M18	NW25	25	1	1
E2M28	NW25	25	0.8	0.7
E2M40	ISO40	40	3.5	3.5
E2M80	ISO40	40	2	1.5
E2M175	ISO63	70	7	7
E2M275	ISO63	70	4.5	4.5

Table 2 – Maximum pipe lengths, for a maximum decrease in pumping speed of 20% at 0.5 mbar

Conversions

Pressure Units

	mbar	bar	Torr	Pa (Nm ⁻²)	atm	lbf inch ⁻²
1 mbar =	1	1 x 10 ⁻³	0.75	10 ²	9.87 x 10 ⁻⁴	1.45 x 10 ⁻²
1 bar =	10 ³	1	7.5 x 10 ²	1 x 10 ⁵	0.987	14.5
1 Torr =	1.33	1.33 x 10 ⁻³	1	1.33 x 10 ²	1.32 x 10 ⁻³	1.93 x 10 ⁻²
1 Pa (Nm ⁻²) =	0.01	1 x 10 ⁻⁵	7.5 x 10 ⁻³	1	9.87 x 10 ⁻⁶	1.45 x 10 ⁻⁴
1 atm =	1.01 x 10 ³	1.01	7.6 x 10 ²	1.01 x 10 ⁵	1	14.7
1 lbf inch ⁻² =	68.9	6.89 x 10 ⁻²	51.71	6.89 x 10 ³	6.80 x 10 ⁻²	1
1 kgf cm ⁻² =	9.81 x 10 ²	0.98	7.36 x 10 ²	9.81 x 10 ⁴	0.97	14.2
1 inch Hg =	33.9	3.39 x 10 ⁻²	25.4	3.39 x 10 ³	3.34 x 10 ⁻²	0.49
1 mm Hg =	1.33	1.33 x 10 ⁻³	1	1.33 x 10 ²	1.32 x 10 ⁻³	1.93 x 10 ⁻²
1 inch H ₂ O =	2.49	2.49 x 10 ⁻³	1.87	2.49 x 10 ²	2.46 x 10 ⁻³	3.61 x 10 ⁻²
1 mm H ₂ O =	9.81 x 10 ⁻²	9.81 x 10 ⁻⁵	7.36 x 10 ⁻²	9.81	9.68 x 10 ⁻⁵	1.42 x 10 ⁻³

	kgf cm ⁻²	inch Hg	mm Hg	inch H ₂ O	mm H ₂ O
1 mbar =	1.02 x 10 ⁻³	2.95 x 10 ⁻²	0.75	0.40	10.2
1 bar =	1.02	29.53	7.5 x 10 ²	4.01 x 10 ²	1.02 x 10 ⁴
1 Torr =	1.36 x 10 ⁻³	3.94 x 10 ⁻²	1	0.54	13.6
1 Pa (Nm ⁻²) =	1.02 x 10 ⁻⁵	2.95 x 10 ⁻⁴	7.5 x 10 ⁻³	4.01 x 10 ⁻³	0.102
1 atm =	1.03	29.92	7.6 x 10 ²	4.07 x 10 ²	1.03 x 10 ⁴
1 lbf inch ⁻² =	7.03 x 10 ⁻²	2.04	51.71	27.68	7.03 x 10 ²
1 kgf cm ⁻² =	1	28.96	7.36 x 10 ²	3.94 x 10 ²	1 x 10 ⁴
1 inch Hg =	3.45 x 10 ⁻²	1	25.4	13.6	3.45 x 10 ²
1 mm Hg =	1.36 x 10 ⁻³	3.94 x 10 ⁻²	1	0.54	13.60
1 inch H ₂ O =	2.54 x 10 ⁻³	7.36 x 10 ⁻²	1.87	1	25.4
1 mm H ₂ O =	10 ⁻⁴	2.90 x 10 ⁻³	7.36 x 10 ⁻²	3.94 x 10 ⁻²	1

Note also: 1 dyn cm⁻² (barye) = 0.1 Pa (Nm⁻²) = 10⁻³ mbar

Leak Rate Units

	mbar l s ⁻¹	Torr l s ⁻¹	atm cm ³ s ⁻¹	lusec	atm ft ³ min ⁻¹
1 mbar l s ⁻¹ =	1	0.75	0.99	7.5 x 10 ²	2.09 x 10 ⁻³
1 Torr l s ⁻¹ =	1.33	1	1.32 x 10 ³	10 ³	2.79 x 10 ⁻³
1 atm cm ³ s ⁻¹ =	1.01	0.76	1	7.6 x 10 ²	2.12 x 10 ⁻³
1 lusec =	1.33 x 10 ⁻³	1 x 10 ⁻³	1.32 x 10 ⁻³	1	2.79 x 10 ⁻⁶
1 atm ft ³ min ⁻¹ =	4.78 x 10 ²	3.59 x 10 ²	4.72 x 10 ²	3.59 x 10 ⁵	1

Pumping Speed Units

	l s ⁻¹	l min ⁻¹	ft ³ min ⁻¹	m ³ h ⁻¹
1 l s ⁻¹ =	1	60	2.119	3.60
1 l min ⁻¹ =	0.017	1	0.035	0.06
1 ft ³ min ⁻¹ =	0.472	28.317	1	1.699
1 m ³ h ⁻¹ =	0.278	16.667	0.589	1

Material Safety Data Sheets

The following data sheets are available on request

P110-11-000	Mechanical pump oil - Supergrade	P120-11-110	Cartridge grease - Shell Darina® EP grease 2
P110-20-100	Oil Apiezon® AP303	P120-20-010	1-Methoxy-2-Propanol
P120-01-000	Mechanical pump oil – 45	P120-20-020	Emerald lacquer
P120-01-005	Mechanical pump oil – TW	P120-20-030	Emerald primer
P120-01-010	Mechanical pump oil – Ultragrade 15, 19, 20, 70	P120-20-040	Isopropanol anhydrous
P120-01-030	Drynert 25/6, gear box lubricant	P120-20-050	Potassium hydroxide solution
P120-01-050	Synfilm GT Oil	P120-20-060	Visioncoat 2000
P120-02-000	Oil – Apiezon® A, AP201, B, BW, C & G	P120-20-070	Visioncoat 2000 solvent
P120-02-005	Oil – Apiezon® J & K	P120-20-080	Optical 10L fluid
P120-02-010	Oil – Apiezon® AP301	P120-20-090	Super II fluid
P120-02-015	Diffusion pump fluid – DC702, 704EU & 705	P120-20-100	Hexid fluid
P120-02-025	Diffusion pump fluid – Edwards L9	P120-20-110	In-situ hydrophobic monomer
P120-03-000	Grease – Fomblin® (AR555)	P120-20-130	Exchange carbon
P120-03-005	Grease – Krytox® series 240 & LVP fluorinated greases	P120-20-140	Exchange resin
P120-03-010	Grease – Apiezon® H & T	P120-20-160	Zirconium
P120-03-015	Grease – Apiezon® L & M	P120-30-010	XDS black tip seal dust
P120-03-025	Grease – Apiezon® AP101	P120-30-015	XDS light brown tip seal dust
P120-03-030	Grease – Apiezon® AP100	P120-40-020	Sodium fluoride
P120-03-035	Grease – Silicone high vacuum	P120-40-060	Aquareus ion exchange resin
P120-03-040	Fomblin® CR 861	P120-70-005	Rotary pump blade material -F43
P120-03-045	DEFRIC COAT D1-C	P120-70-010	Rotary pump blade material -F32
P120-03-050	DEFRIC COAT D1-C solvent		
P120-04-000	Wax – Apiezon® W & W40		
P120-04-005	Wax – Sealing compound Apiezon® Q		
P120-04-015	O-rings – Viton®		
P120-04-020	O-rings – Nitrile & rubber vacuum		
P120-04-025	O-rings – Kalrez®		
P120-04-030	Indium metal seals		
P120-04-035	O Rings - Fluoroelastomer (VAT)		
P120-05-000	GS battery		
P120-05-005	Grease – Asonic GHY72		
P120-06-000	Coolant – Edwards Drystar® 2		
P120-06-005	Coolant – HT110		
P120-07-000	Refrigerant – Edwards chiller (SUVA HP62)		
P120-08-000	GRC cartridges – C150Y/C150R/C150JV/C150W/CM10Y		
P120-08-005	End point detector fluid		
P120-08-010	Pipe insulation jackets		
P120-08-015	Thermal processing/conditioning system TPU-TCS		
P120-08-020	GRC cartridges – C150A/C7150A		
P120-08-025	GRC cartridges – C250Y		
P120-09-000	Alumina grade A (activated alumina)		
P120-09-005	Activated charcoal AC35		
P120-09-010	Rotary pump blade material – CX2		
P120-09-020	Rotary pump blade material – GE21		
P120-09-025	Polytetrafluoroethylene PTFE		
P120-10-000	Leak detection/ion gauge filaments		
P120-11-010	V Lube B		
P120-11-020	V Lube F US version		
P120-11-025	V Lube F European version		
P120-11-030	V Lube G		
P120-11-040	V Lube H		
P120-11-080	Heat transfer fluid		
P120-11-100	Sealant – silicone liquid gasket		

Trade Marks

Edwards, Barocel, Diffstak, Drystar, Speedivac are trademarks of Edwards Limited.

Notice - Dimensions

Although every care has been taken in the preparation of dimensional drawings no responsibility can be taken for customers' work processed from this catalogue. Unless otherwise stated all dimensions are in mm (inches).

Notice - Accessories

Accessories are occasionally included in illustrations and dimension drawings for clarity or convenience. In general this is indicated on the drawing or in the adjacent text but in the case of doubt, please verify the status of such components before ordering.

Edwards is an ISO9001 (BS5750) certified organization.



Certificate numbers:
FM21010, FM39455, FM25009,
FM32104, FM59924 and FS23443.

All goods listed in this catalogue are offered subject to our standard conditions of sale. Copies available on request.

We reserve the right to change specifications without notice.

© This catalogue is copyright and no part of it may be reproduced without our written permission.

Publication C10009895



Notes





Notes





Notes





Notes





Notes



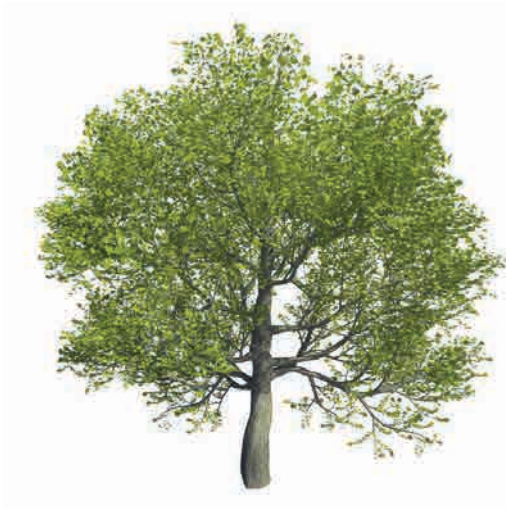

RoHS Compliance

The EU RoHS (Restriction of certain Hazardous Substances) Directive controls the use of certain hazardous substances (lead, mercury, cadmium, hexavalent chromium, PBDE and PBE) in electrical and electronic equipment. Similar legal requirements have been implemented in many other countries.

Edwards products do not fall within the scope of the RoHS Directive, but we have a voluntary programme of RoHS compliance as part of our commitment to protecting the environment.

A wide range of Edwards products are RoHS compliant including iX semiconductor dry pumps, small rotary pumps, scientific turbo pumps, STP magnetically levitated turbo pumps, industrial dry and roots pumps, scroll pumps, vacuum gauges and controllers, vacuum system components and flange fittings. Refer to our website for the latest information.

These items do not contain the following materials above the limits set by the European RoHS Directive, 2002/95/EC. These limits are set out in the table below.

Substance	TypicalUses	Limits** (by weight of the homogeneous material*)
Lead	Solders, pigments, PVC stabilisers, balance weights	0.1 wt%
Cadmium	Pigments, plastics stabilisers, platings, batteries, contacts	0.01 wt%
Mercury	Switch and relay contacts, batteries, sensors, fluorescent tubes	0.1 wt%
Hexavalent Chromium	Coatings and platings (esp Aluminium), metallised plastics	0.1 wt%
PBB	Flame retardant, no longer produced	0.1 wt%
PBDE	Flame retardants for variety of plastics	0.1 wt%

* A single substance that could (theoretically) be mechanically separated from other substances

** The EU Directive allows various exemptions – see 2002/95/EC <http://ec.europa.eu/environment/waste/weee/>



UNITED KINGDOM - HEAD OFFICE

Crawley Business Quarter, Manor Royal,
Crawley, West Sussex RH10 9LW
Tel: Sales & Service +44 8459 212223
Office +44 1293 528844
Fax: Sales & Service +44 1293 533453

USA

Highwood Office Park, One Highwood Drive Suite
101, Tewksbury, MA 01876
Tel: Toll free (USA) +1 800 848 9800
Fax: Office +1 866 484 5218

CANADA

5860 Chedworth Way, Mississauga,
Ontario L5R 0A2
Tel: Office +1 800 387 4076
Fax: Office +1 905 501 1225

BRAZIL

Rua Bernado Wrona, 222
02710-060 - Sao Paulo - SP, Brazil
Tel: Office +55 11 3952 5000
Fax: Office +55 11 3965 2766

BELGIUM

Bergensesteenweg 709
BE- 1600 Sint-Pieters-Leeuw
Tel: Office +32 2 300 0730
Fax: Office +32 2 300 0704

ITALY

Via Vittore Carpaccio 35
20090 Trezzano sul Naviglio, Milano
Tel: Office +39 02 48 4471
Fax: Office +39 02 48 401638

GERMANY

Ammerthalstrasse 36,
85551 Kirchheim, Munich
Tel: Sales & Service 0800 000 1456
Fax: Sales & Service +49 899 919 1888

FRANCE

101 rue de la Bongarde,
92238 Gennevilliers, Cedex
Tel: Sales & Service +33 1 4121 1256
Office +33 1 4798 2401
Fax: Sales & Service +33 1 4121 1238

ISRAEL

5 Habarzel Blvd. Gat 2000 Industrial Zone,
PO Box 862, Qiryat Gat 200901
Tel: Sales +972 8 681 0633
Service +972 7 681 0633
Fax: Office +972 8 681 0640

CHINA

23 Fu Te Road (North)
Wai Gao Qiao Free Trade Zone,
Pudong, Shanghai 200131
PR China
Tel: Sales +86 21 5866 9618
Service +86 21 5866 9618 ext 152
Fax: Office +86 21 5866 9993
+86 21 5868 2533

JAPAN

1078-1 Yoshihashi, Yachiyo-shi,
Chiba 276-8523, Japan
Tel: Sales +81 47 458 8831
Service +81 47 458 8851
Fax: Sales +81 47 458 8835
Service +81 47 458 8048

SINGAPORE

42 Loyang Drive, Loyang Industrial Estate
Singapore 508962
Tel: Office +65 6546 8408
Fax: Office +65 6546 8407

TAIWAN

No.1, Renyi Street, Jhunan Town,
Miaoli County 350, Taiwan (R.O.C.)
Tel: Office +886 37 581000
Fax: Office +886 37 581608

KOREA

5F Hanwon Building, 6-1 Sunae-dong,
Bundang-gu, Seongnam-si,
Gyeonggi-do, Korea
Tel: Office +82 31 716 7070
Fax: Office +82 31 710 2222

INDIA

T97/2, Opposite Saint Gobain
Bhosari MIDC, Pune 411026, India
Tel: Sales +91 20 4075 2222
Service +91 20 4075 2207
Fax: Sales +91 20 4075 2212
Service +91 20 2712 0548

www.edwardsvacuum.com
info@edwardsvacuum.com