

This document courtesy of:



[Data Weighing Systems, Inc.](#)

[Contact Us](#)

For immediate assistance call
1-800-750-6842

Operating Instructions

Sartorius LA Reference

LA Models
Electronic Analytical and Precision Balances

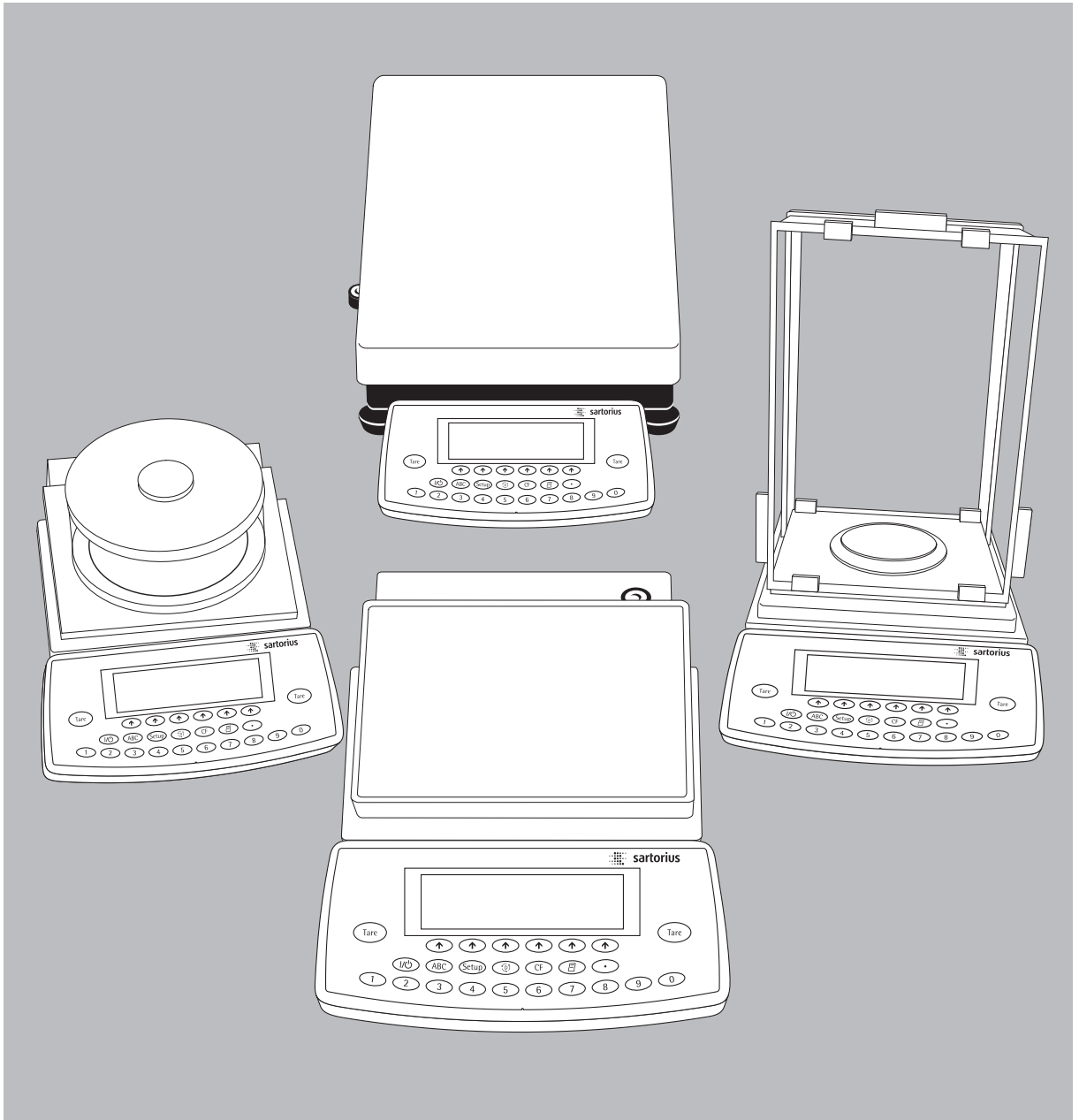

Intended Use

The LA Reference Series from Sartorius offers precision balances for measurement of mass (weight). The balances in this series have capacities ranging from 0.1 mg to 64 kg.

A broad range of special performance features make the LA Reference balances ideal for use as measuring and test equipment in ISO or GLP quality management systems.

These features include:

- The fully automatic self-calibrating and adjustment function, isoCAL (time- and temperature-dependent)
- reproTEST for quick determination of the standard deviation to check the reproducibility of results
- ISO/GLP-compliant recording capability for printouts
- Password-protected menu lock

LA Reference balances meet the highest requirements on the accuracy and reliability of weighing results through the following features:

- Efficient filtering-out of vibration
- Stable and reproducible results
- Excellent readability under any lighting conditions
- Rugged, durable weighing system

LA Reference balances save work and speed up simple routine applications through:

- Ultrafast response times
- Built-in application programs, including
Application 1:
 - Toggling between two weight units
 - Counting
 - Weighing in percent
 - Animal weighing
 - Recalculation
 - Calculation
 - Density determination
 - Differential weighing
 - Air buoyancy correction
 - Diameter determination

Application 2:

- Checkweighing
- Time-controlled functions

Application 3:

- Totalizing
- Formulation
- Statistics

with the following additional functions:

- Second tare memory
- Identification codes
- Product data memory
- SQmin function
- Manual data storage in application level 3
- DKD uncertainty of measurement
- Automatic initialization when you switch on the balance
- Easy input of alphanumeric sample, lot and balance IDs
- Flexible, easy-to-use display and control unit
- Optional connectivity for control through an on-line computer

Hotline:

For advice on the use of these applications, just call or fax your local Sartorius office. For the address, please visit our Internet website at: www.sartorius.com

Contents

2	Intended Use
2	Contents
3	Safety Precautions
3	Operating Design
7	Getting Started
	Configuration
12	Setting the Language
13	Navigating in the Setup Menu
14	Entering Date and Time
15	Setting the Balance Functions
16	Balance Functions (Overview)
18	Setting the Device Parameters
18	Entering a Password
22	Setting the Application Parameters
30	Selecting the Printout Function
31	Printout Parameters (Overview)
32	Printout Configuration
34	Device Information
	Operation
35	Basic Weighing Function
38	Device Parameters
40	Calibration/Adjustment
49	Application Programs
49	Toggle between Two Weight Units
51	Counting
54	Weighing in Percent
57	Animal Weighing
61	Calculation
63	Density Determination
68	Differential Weighing
79	Checkweighing
84	Time-controlled Functions
86	Totalizing
90	Formulation
93	Statistics
97	Additional Functions
97	Second Tare Memory
99	Individual Identification Codes
103	Saving Values Manually
104	Product Data Memory
106	SQmin Function
108	DKD Uncertainty of Measurement
110	Combining Applications
111	Examples of Application Combinations
113	Data Output Functions
122	Pin Assignment Chart
124	Error Codes and Messages
127	Care and Maintenance
128	Instructions for Recycling
129	Overview
129	General Views
133	Specifications
140	Accessories (Options)
141	Declaration of Conformity
143	EC Type Approval
145	Plates and Markings
146	Index
	Appendix
	Entering the General Password

Safety Precautions

This balance has been constructed in accordance with the European Directives as well as international regulations and standards for operation of electrical equipment, electromagnetic compatibility, and stipulated safety requirements. Improper use or handling, however, can result in damage and/or injury.

Read these operating instructions thoroughly before using your balance to prevent damage to the equipment. Keep these instructions in a safe place.

Follow the instructions below to ensure safe and trouble-free operation of your balance:

- ⚠ Do not use this balance in a hazardous area/location
- ⚠ Make sure that the voltage rating printed on the AC adapter is identical to your local line voltage
- The only way to switch the power off completely is to disconnect the AC adapter
- Type of protection for the housing:
 - Balances with a readability ≤ 0.1 mg comply with IP42
 - LA64001S, LA34001S, LA16001S, LA34001P and LA34000 meet IP44 requirements
 - Additional balances with a readability ≤ 1 mg comply with IP54
 - AC adapters meet IP20 requirements
- Protect the AC adapter from contact with liquid.
 - Connect only Sartorius accessories and options, as these are optimally designed for use with your LA Reference balance.

- Meaning

ABC Alphabetic keys
Please see section on "Text Input"
- I/O** On | off key
Turns the balance on and off or switches it to the standby mode
- Setup** Menu settings
Accesses and exits the Setup menu
- Toggle** Toggles to the next application program
- CF** Clear function
Deletes keypad input
Interrupts a calibration and adjustment routine in progress
Quits application programs
- Print** Print key
Outputs displayed values or data logs to the serial communications and | or printer port

Operating Design

When cleaning your balance, make sure that no liquid enters the balance housing; use only a slightly moistened cloth to clean the balance.

Do not open the balance housing. If the seal is broken, this will result in forfeiture of all claims under the manufacturer's warranty.

In case you have any problems with your balance:

- contact your local Sartorius office, dealer or service center

Operating Design

The balances in the LA Reference Series consist of a weighing cell and a display and control unit. In addition to the choice of power supply (via AC adapter or external rechargeable battery pack), your balance also has an interface port for connecting a printer, computer or universal remote control switch.

The display and control unit and the weighing cell can be set up separately. Operation of LA Reference balances follows a uniform "philosophy" which is described in this manual. Where not expressly indicated otherwise, the uses described in this manual apply to verified and verifiable balance versions (indicated by the suffix "-OCE" in the model number), as well as the standard version.

Combination of Several Applications

You can combine the use of various application programs to meet your more complicated requirements. To select application programs one after the other, press **Toggle** (toggle function).

Keys

Your LA Reference balance is operated either by using the keys on the display and control unit or via a connected PC. Operation by means of the balance keys is described in the following.

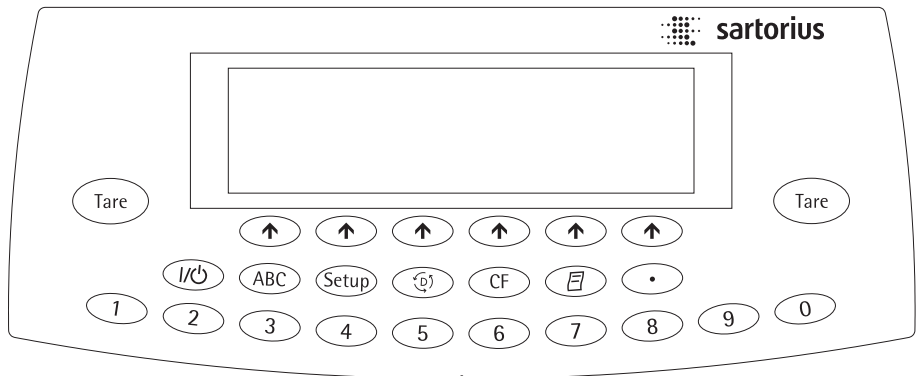

- **·** Enters a decimal point
- **1 ... 9 0** keys
See the section on "Numeric Input"

Tare Tares the balance

Numeric Input

To enter numbers:
press **1 ... 9 0 ·**

To store numbers entered: press the corresponding function key directly below the soft key label

To delete an entire numeric input digit by digit: press the **CF** key

Text Input

- To enter numbers:
see the section on "Numeric Input"

- To enter letters or characters:
press the **ABC** key
- > Letters are displayed in the bottom line for selection
- To select a different letter: press the corresponding soft key to change the letter shown
- To select the letter | character shown: press the corresponding function key below the soft key label
- > The selected letter is shown on the display
- Enter the next letter | character, if desired, as described above
- To exit the letter input mode (e.g., if the last character entered is a letter): press the **ABC** key
- To store a word: press the corresponding function key (soft key), such as **I D**
- To delete an input character by character: press the **CF** key
- To delete user data: enter **·** or a space and save

Operating Design

Function Keys (Soft Keys)

The current function of soft keys is indicated in the bottom line of the display (footer).

Texts (abbreviations) or symbols can be displayed.

Texts (Examples)

C a l: Start calibration | adjustment
S I D: Save ID

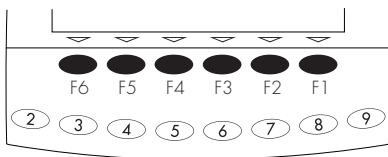

The function keys are numbered from right (F1) to left (F6).

Symbols

The bottom line shows the following symbols:

- ◀◀ Back to the initial state
(in the Setup menu: exit Setup)
- ◀ Go to the higher selection level
- Show sub-items under the active item
- ▲ Move upward in the input | output window
- ▼ Move downward in the input | output window
- ⏴ Set the selected menu parameter

Labeled Keys

These keys always have the function indicated, but are not available at all times. Availability of these functions depends on the current operating status and menu settings.

There are two fundamentally different types of display:

- display for weights and calculated values
- display for menu parameter settings (setup)

Operation

Display for Weights and Calculated Values

This display is subdivided into 9 areas.

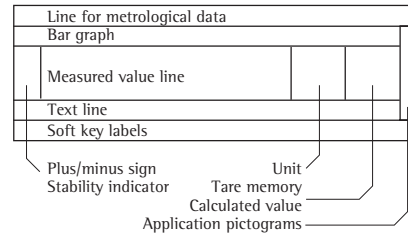

Line for Metrological Data:

When the balance is used in legal metrology, the following metrological specifications of the balance are shown here:

- M a x** Maximum capacity (upper range limit) of the balance
- M i n** Minimum capacity (lower range limit) of the balance
- R 1** to **R 4** Display when $e = d$
- e** Verification scale interval
- d** Readability | scale interval

On standard balances, only **M a x** and **d** are displayed.

Bar Graph:

The bar graph indicates how much of the balance's capacity is "used up" by the current load; during checkweighing, it indicates the control limits.

Bar Graph:

The bar graph indicates how much of the balance's capacity is "used up" by the current load; during checkweighing, it indicates the control limits.

The following symbols may be displayed:

- 0%** Lower load limit
- 100%** Upper load limit
- Bar graph showing 10% intervals
- Minimum for checkweighing
- = Target for checkweighing
- + Maximum for checkweighing

Plus/Minus Sign, Stability Symbol:

A plus or minus sign (+ or -) is shown here for a weight (or a calculated value, such as that for counting), or the symbol indicating that a verified balance¹⁾ has been zeroed or tared.

Line for Measured Values:

This area shows the weighed or calculated value and the alphanumeric input.

Note Concerning Verified Balances Approved for Use as Legal Measuring Instruments in the EU*:

For verified balances that have a verification scale interval **e** which is greater than the scale interval **d**, the last digit on the display is bordered.

Unit and Stability:

When the balance reaches stability, the weight unit or calculated unit is displayed here.

When the symbol is displayed here, the value indicated in the readout cannot be used in legal metrology.

* including the Signatories of the Agreement on the European Economic Area
¹⁾ Verification scale interval "e" is equal to scale interval "d"

Tare Memory, Calculated Values:
The symbols displayed here indicate when there is a value in one of the tare memories or when the value shown is a result of calculation rather than direct measurement.

These symbols are as follows:





 Calculated value

NET1 Net value | tare memory

NET2 used by an application program (e.g., formulation, second tare memory)

Application Pictograms:
The pictograms displayed here indicate the application(s) selected. The pictogram is displayed inversely (white on a black background) when the corresponding application is active.

For example, the following symbols may be displayed simultaneously:

-  The counting application is active
-  Checkweighing is also active
-  Print
-  Data record

Text Line:
Additional information is displayed here (e.g., operator guidance prompts, name of the active program, etc.)

Soft Key Labels:
The current functions of the soft keys above the function keys (arrow keys) are indicated here; during calibration | adjustment, this line shows up- and down-arrows (↕ and ↘) for selecting calibration and adjustment functions.

Display for Menu Parameter Settings (Setup)

This display is divided into three sections.

Line for Operating State
Input and Output Window
Soft Key Labels

Status Line:
The status line of shows the function of the display screen page. In the Setup menu, the current menu “path” is shown here.

Setup Menu Example: “Balance/scale functions”:

SETUP	BAL. FUNC.

Input and Output Window
This window contains either detailed information (e.g., on the active application) or a pick list. A selected item is displayed inversely (white characters on a black background). You can also enter information in an active field in this window using the alphabetic and numeric keys.

Setup Menu Example, “Device parameters, Adapt filter”:

Minimum vibration
 Normal vibration
Strong vibration
Extreme vibration

The following symbol may be displayed in the input and output window:

-  this symbol marks the saved menu setting

Soft Key Labels
See the description “Function Keys (Soft Keys)” on the previous page

To set a parameter:
● Press the ↕ or ↘ soft key repeatedly until the desired setting is selected (displayed inversely)

● Confirm your selection:
press the ↵ soft key

To change the numeric value of a parameter:
● Press the ↕ or ↘ soft key repeatedly, if necessary, until the desired setting is selected (displayed inversely)

● Enter a new value or character:
use the (0) (1) ... (9) (.) keys or the (ABC) key and enter the desired letters

● Confirm your selection:
press the ↵ soft key

To exit Setup: press the ⏪ soft key

Input

Bar Code Scanner or Keyboard Input

You can use a bar code scanner or an external keyboard to input alphanumeric values. These inputs are processed in the same manner as keypad inputs on the display and control unit of the balance. Bar code and keyboard inputs are only displayed; they cannot activate any function.

To assign a bar code scanner or keyboard input to a function, press one of the following soft keys:

- Lot
- Samples
- Measured values
- Sample number
- Tare value
- Initial weight
- Backweighed value
- Sample ID

Foot or Hand Switch Input

You can connect a foot switch or a hand switch to the balance to have this device perform a keypad function (such as (CF) or (Tare)).

PC Input

You can use a computer to control the functions of the weighing cell and display and control unit via the communications port (see the “Data Output Function” section in the chapter entitled “Operation”).

Data Output

Your LA Reference balance is equipped with an interface port for connecting your choice of the following:

- Printer
- Peripheral device (e.g., computer)
- Universal remote control switch

Printer

You can configure the print functions to meet your individual requirements by selecting the corresponding menu code.

You can have printouts generated automatically, or by pressing ; dependent on or independent of the stability or time parameters; with or without IDs; and as standard or ISO/GLP-compliant printouts.

ISO: International Organization for Standardization

GLP: Good Laboratory Practice

See the section on “Data Output Functions” in the chapter entitled “Operation” for a detailed description of data output options.

Interface Port

Instead of a printer, you may choose to connect a different peripheral device, e.g. a computer (PC). With an on-line PC you can control both the weighing cell and the display unit of the LA Reference balance.

Request messages are sent via the interface to initiate functions in the weighing cell and in the display unit. Some of the functions generate response messages.

See the chapter entitled “Operation” under the section on “Data Output” for a detailed description of the interface port.

Error Codes

If you press a key that has no function, or which is blocked at a certain point in an application program, this error is indicated as follows:

- a double-beep is sounded as an acoustic signal if the key has no function
- a double-beep is sounded and a message is displayed for 2 seconds in the text line if the key function is not available at that time

The response to an operator error is identical in all models of the LA Reference series. See the chapter entitled “Error Codes” for a detailed description.

Storing Settings

Storing Parameter Settings

The settings configured are stored in the balance’s non-volatile memory. The most recent parameter settings are active when you switch on the balance.

Saving Parameter Settings

You can assign passwords in order to block access to:

- Weighing parameters
- Device parameters
- Application parameters
- Factory settings

Getting Started

Storage and Shipping Conditions

- Do not expose the balance to extreme temperatures, jolts, impacts, vibration or moisture.

Unpacking the Balance

- After unpacking the balance, check it immediately for any visible damage as a result of rough handling during shipment.
- If this is the case, proceed as directed in the chapter entitled "Care and Maintenance," under the section on "Safety Inspection."

It is a good idea to save the box and all parts of the packaging until you have successfully installed your balance. Only the original packaging provides the best protection for shipment. Before packing your balance, unplug all connected cables to prevent damage.

Important Note Concerning Verified Balances Approved for Use as Legal Measuring Instruments in the EU*

Provided that an official seal is required for the verified balance, a control seal is affixed to the balance. This seal will be irreparably damaged if you attempt remove it. If the seal is broken, the validity of the verification will become void and you must have your balance re-verified.

Equipment Supplied

The equipment supplied includes the components listed below:

LA balances with a readability of 0.1 mg

- Balance with display and control unit
- AC adapter
- Dust cover
- Bushing
- Shield plate
- Shield disk
- Weighing pan
- USB interface cable

LA balances with a readability of 1 mg

- Balance with display and control unit
- AC adapter
- Dust cover
- Shield disk
- Pan support
- Weighing pan
- Glass draft shield cylinder
- Draft shield cover
- USB interface cable

LA8200S, LA8200P, LA 6200S, LA 4200S, LA 2200S, LA 820, LA 420, LA 2200P, LA 5200P

- Balance with display and control unit
- AC adapter
- Dust cover
- Pan draft shield
- Weighing pan
- USB interface cable

LA 12000S, LA 6200, LA 4200, LA 2200, LA 12000P

- Balance with display and control unit
- AC adapter
- Dust cover
- Weighing pan
- USB interface cable

LA balances with a capacity ≥ 16 kg

- Balance with display and control unit
- AC adapter
- Dust cover
- Weighing pan
- Dust cover for the display and control unit
- USB interface cable

Installation Instructions

When choosing a location to set up your balance, observe the following so that you will be able to work with added speed and accuracy:

- Avoid placing the balance in close proximity to a heater or otherwise exposing the balance to heat or direct sunlight
- Protect the balance from drafts that come from open windows or doors
- Do not expose the balance to extreme moisture over long periods
- Avoid exposing the balance to extreme vibrations during weighing
- Set up the balance on a stable, even surface
- Protect the balance from aggressive chemical vapors

Conditioning the Balance

Moisture in the air can condense on the surfaces of a cold balance whenever it is brought into a substantially warmer place. If you transfer the balance to a warmer area, make sure to condition it for about 2 hours at room temperature, leaving it unplugged from AC power.

* including the Signatories of the Agreement on the European Economic Area

Setting up the Balance

Preparing Balances with Analytical Draft Shield Chambers

- Place the components listed below on the balance in the order given:
 - Bushing (pan adapter)
 - Shield plate
 - Shield disk
 - Weighing pan

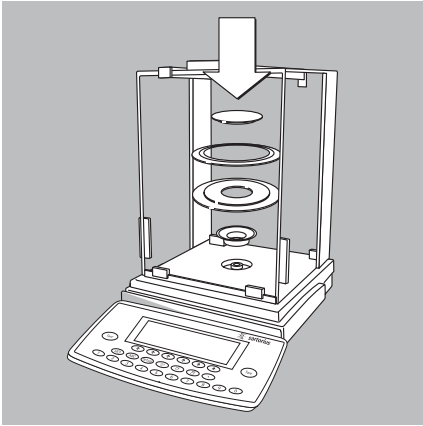

Preparing Balances with a Round Glass Draft Shield

- Place the components listed below on the balance in the order given:
 - Dust cover
 - Protective disk; turn counter-clockwise until it stops and is secure
 - Pan support
 - Weighing pan
 - Glass draft shield cylinder
 - Draft shield cover

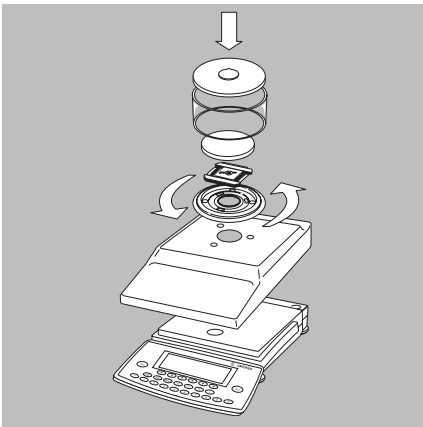

Preparing Balances with a Rectangular Weighing Pan and a Weighing Capacity ≤ 12 kg

- Place the components listed below on the balance in the order given:
 - Dust cover
 - Weighing pan draft shield (only for balances with a readability of 0.01 g)
 - Weighing pan

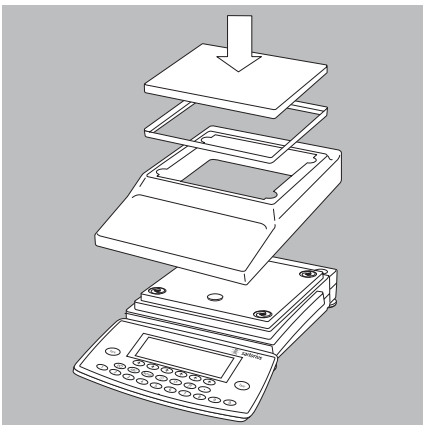

Preparing Balances with a Rectangular Weighing Pan and a Weighing Capacity ≥ 16 kg

- Place the weighing pan on the balance

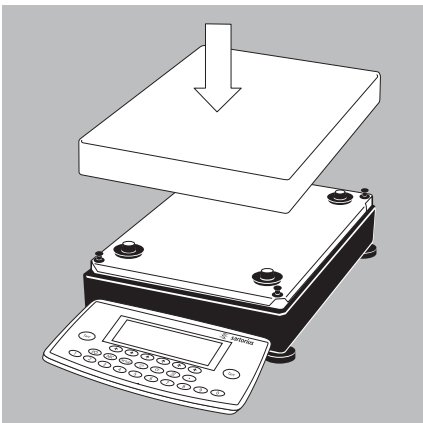

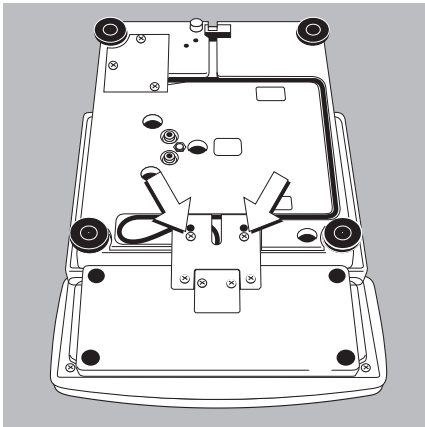

Separate Operation of the Display Unit

- Turn the balance on its side and lay it on a padded surface to avoid damage to the weighing system
- Use a screwdriver to remove the 2 screws from the display unit retainer
- Remove the display unit
 - > Cable lengths
 - LA balances with a weighing capacity ≤ 12 kg: 55 cm
 - LA balances with a weighing capacity > 12 kg: 80 cm
 - See the chapter entitled "Accessories" for information on longer cables
 - If you wish to use a longer cable, it must be installed by an authorized Sartorius service technician

Options for Mounting the Display Unit for LA Balances with a Weighing Capacity ≥ 16 kg

The display unit can be mounted as follows:

- on the short side of the weighing cell (factory mounting)
- on the back (long side) of the weighing cell

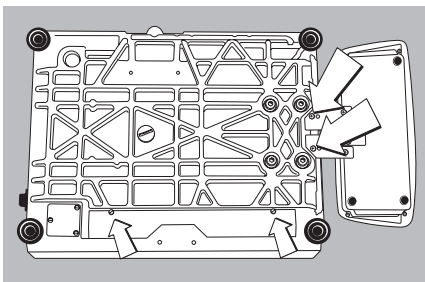

- Turn the weighing cell over
- Remove the fastening screws from the display unit retainer
- Remove the fastening screws from the plate that covers the cable raceway (channel) and remove the plate

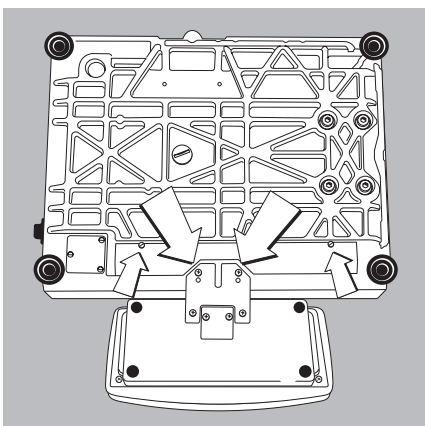

- Fasten the display retainer onto the back of the weighing cell with the 2 Allen screws
- Thread the cable through the raceway and replace the cover plate

Connecting the Balance to AC Power

- Check the voltage rating and the plug design
 - If they do not match the rating or standard you use, contact your Sartorius office or dealer
 - Use only
 - Original Sartorius AC adapters
 - AC adapters with a registered approval rating from a national testing laboratory
- To use a main feeder cable from the ceiling or to mount a CEE plug, you will have to make arrangements
- See the chapter entitled “Accessories” for information on using an IP65-protected industrial AC adapter or an external rechargeable battery pack with your balance
- Insert the right-angle plug into the jack and then tighten the screws
- Then insert the plug of the AC adapter into a wall outlet (mains)

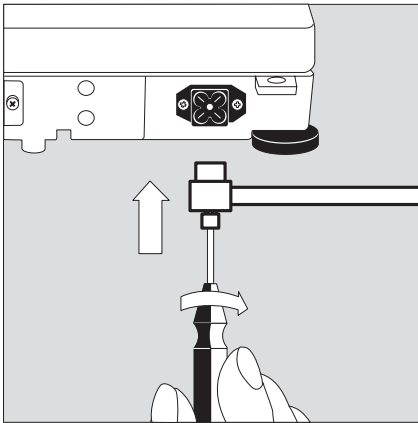

Charging the Rechargeable Battery for Saving Data:

All data is saved in the battery-backed memory. When initially operating the balance, leave it connected to AC power for one day to charge the battery. When the balance is disconnected from AC power, the balance-generated data will remain stored for approximately three months. In the standby mode, data is retained in the memory via the power supply. Be sure to print out data before storing your balance for a relatively long period.

Safety Precautions

The AC adapter rated to Class 2 can be plugged into any wall outlet without requiring any additional safety precautions. The ground or earth terminal is connected to the balance housing, which can be additionally grounded, if required. The data interface is also electrically connected to the balance housing (ground).

Note:

This equipment has been tested and found to comply with the limits pursuant to part 15 of the FCC Rules. These limits are designed to provide reasonable protection against harmful interference. This equipment generates, uses and can radiate radio frequency energy and, if not installed and used in accordance with these instructions, may cause harmful interference to radio communications.

For information on the specific limits and class of this equipment, please refer to the Declaration of Conformity. Depending on the particular class, you are either required or requested to correct the interference.

If you have a Class A digital device, you need to comply with the FCC statement as follows: “Operation of this equipment in a residential area is likely to cause harmful interference in which case the user will be required to correct the interference at his own expense.”

If you have a Class B digital device, please read and follow the FCC information given below: However, there is no guarantee that interference will not occur in a particular installation. If this equipment does cause harmful interference to radio or television reception, which can be determined by turning the equipment off and on, the user is encouraged to try to correct the interference by one or more of the following measures:

- Reorient or relocate the receiving antenna.
- Increase the separation between the equipment and receiver.
- Connect the equipment into an outlet on a circuit different from that to which the receiver is connected.
- Consult the dealer or an experienced radio/TV technician for help.

Before you operate this equipment, check which FCC class (Class A or Class B) it has according to the Declaration of Conformity included. Be sure to observe the information of this Declaration.

Connecting Electronic Peripheral Devices

- Make absolutely sure to unplug the balance from AC power before you connect or disconnect a peripheral device (printer or PC) to or from the interface port.

Warmup Time

To ensure accurate results, the balance must warm up for at least 30 minutes the first time it has been connected to AC power and each time after it has been unplugged from AC power and reconnected. Only after this time will the instrument have reached the required operating temperature.

Using Verified Balances Approved for Use as Legal Measuring Instruments in the EU*:

- The balance must warm up for at least 24 hours after initial connection to AC power or after a relatively long power outage. It needs to warm up for at least 30 minutes each time after it has been disconnected from AC power.
- For balances with a readability of ≤ 0.1 mg: wait until the automatic calibration/adjustment routine has ended. Requirements: see page 47

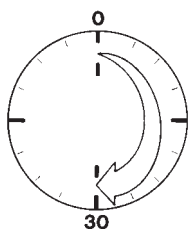
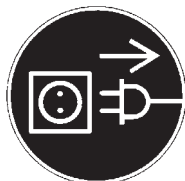

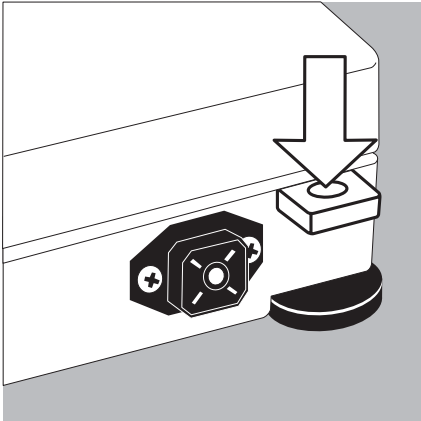

Fastening an Antitheft Locking Device: Balances with a Weighing Capacity ≤ 12 kg
To fasten an antitheft locking device, use the lug located on the rear panel of the balance.

- Secure the balance at the place of installation, e.g., with a chain or a lock.

Leveling the Balance

Purpose:

- To compensate for unevenness at the place of installation
- To achieve perfectly horizontal positioning of the balance for consistent reproducibility

Always level the balance again any time it is moved

Leveling Balances with a Weighing Capacity ≤ 12 kg

Only the 2 front feet are used for leveling.

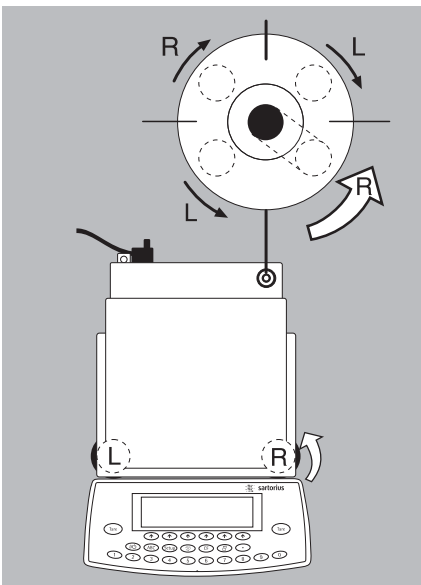

- Retract the 2 rear feet (only for models with rectangular weighing pan)
- Turn the 2 front feet as shown in the illustration until the air bubble is centered within the circle of the level indicator
- > Several leveling steps are usually required.
- When weighing heavy samples (or when the YDH 01 LP display arm is attached):
Extend the 2 rear feet until they touch the surface on which the balance rests

Leveling Balances with a Weighing Capacity ≥ 16 kg

- Adjust the four leveling feet until the air bubble is centered within the circle of the level indicator

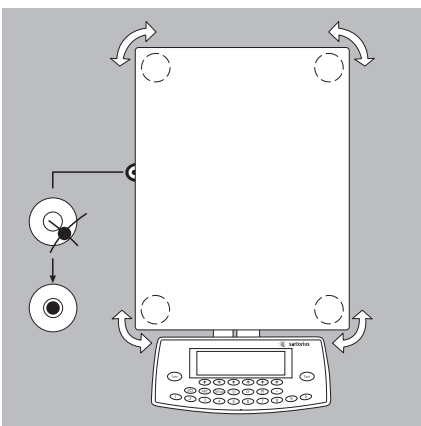

Setting the Language

- > See the "Setting the Language" section in the chapter entitled "Configuration"

Setting the Date and Time

- > See the "Entering Date and Time" section in the chapter entitled "Configuration"

Configuration

Purpose

You can configure the balance to meet individual requirements by entering user data and setting parameters in the Setup program.

The Setup menu contains the following submenus:

- Balance functions
- Device parameters
- Application parameters
- Printout functions
- Device information
- Language
- Factory settings

Setting the Language

You can choose from 5 languages for the information display:

- German
- English (factory setting)
- English with U.S. date | time format
- French
- Italian
- Spanish

Configuring the Balance for Use in Legal Metrology

Set the menu access switch as described below to configure the following functions for use of the balance in legal metrology:

- Display: Verification scale interval: **e**;
lower limit of the weighing capacity: **Min**
- External calibration blocked

Preparation:

- Remove the cap from the back of the balance housing
- Move the switch (1) upwards

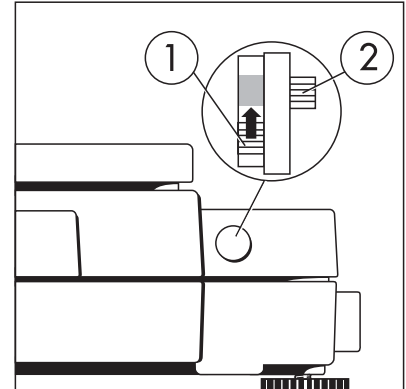

- > When the switch is in the upper position, the Setup menu is locked and the balance can be used in legal metrology

When the switch is in the lower position, the menu is accessible

- > Note:
Do not move Switch 2

Example: Setting the Language to "U.S. Mode"

Step	Press key (or follow instructions)	Display/Output
1. Select "Setup" menu		<pre> SETUP Balance/scale functions Device parameters Application parameters Printout Info << >> </pre>
2. Select "Language" and confirm	Repeatedly press \downarrow soft key, then \rightarrow soft key	<pre> SETUP LANGUAGE Deutsch oEnglish U.S.-Mode Français Italiano << < > </pre>
3. Select "U.S. mode"	\downarrow soft key	<pre> SETUP SPRACHE oDeutsch English U.S.-Mode Français Italiano << < > </pre>
4. Save language	\uparrow soft key	<pre> SETUP LANGUAGE Deutsch oEnglish U.S.-Mode Français Italiano << < ^ > </pre>
5. Exit the Setup menu	\leftarrow soft key	<pre> Max 6200g d= 0.01g 0% 100% 0.00 g Cal </pre>

Navigating in the Setup Menu (Examples):

Example: Adapting the balance to "Extreme vibration"

Step	Press key(s) (or follow instructions)	Display/Output
1. Select Setup menu		<pre> SETUP Balance/scale functions Device parameters Application parameters Printout Info << v >> </pre>
2. Confirm "Balance/scale functions"	> soft key	<pre> SETUP BAL.FUNC. Calibration/adjustment Adapt filter Application filter Stability range Taring << < v >> </pre>
3. Select menu item "Adapt filter" and confirm	↓, then > soft key	<pre> SETUP BAL.FUNC. ADAPT FILT. Minimum vibration oNormal vibration Strong vibration Extreme vibration << < ^ v ↓ </pre>
4. Select menu item "Extreme vibration"	↓ soft key	<pre> SETUP BAL.FUNC. ADAPT FILT. Minimum vibration oNormal vibration Strong vibration Extreme vibration << < ^ ↓ </pre>
5. Confirm menu item "Extreme vibration"	↓ soft key	<pre> SETUP BAL.FUNC. ADAPT FILT. Minimum vibration Normal vibration Strong vibration oExtreme vibration << < ^ ↓ </pre>
6. If required, select further menu items	< v ^ > soft keys	
7. Save setting and exit Setup Menu	<< soft key	

Example: Entering date and time

Step	Press key(s) (or follow instructions)	Display/Output														
1. Select Setup menu; select "Device parameters"	Setup , then ↓ soft key and → soft key	<table border="1"> <tr><td>SETUP</td><td>DEVICE</td></tr> <tr><td>Password</td><td></td></tr> <tr><td>User ID</td><td></td></tr> <tr><td>Clock</td><td></td></tr> <tr><td>Interfaces</td><td></td></tr> <tr><td>Display</td><td></td></tr> <tr><td><<</td><td>< v ></td></tr> </table>	SETUP	DEVICE	Password		User ID		Clock		Interfaces		Display		<<	< v >
SETUP	DEVICE															
Password																
User ID																
Clock																
Interfaces																
Display																
<<	< v >															
2. Set clock	press ↓ repeatedly, then press →	<table border="1"> <tr><td>SETUP</td><td>DEVICE</td><td>CLOCK</td></tr> <tr><td>Time:</td><td></td><td>15.08.10</td></tr> <tr><td>Date:</td><td></td><td>12.09.97</td></tr> <tr><td><<</td><td>< v </td><td></td></tr> </table>	SETUP	DEVICE	CLOCK	Time:		15.08.10	Date:		12.09.97	<<	< v			
SETUP	DEVICE	CLOCK														
Time:		15.08.10														
Date:		12.09.97														
<<	< v															
3. Enter the time	1 1 . 1 2 . 3 0	<table border="1"> <tr><td>SETUP</td><td>DEVICE</td><td>CLOCK</td></tr> <tr><td>Time:</td><td></td><td>11.12.30</td></tr> <tr><td>Date:</td><td></td><td>12.09.97</td></tr> <tr><td>ESC</td><td></td><td>↓</td></tr> </table>	SETUP	DEVICE	CLOCK	Time:		11.12.30	Date:		12.09.97	ESC		↓		
SETUP	DEVICE	CLOCK														
Time:		11.12.30														
Date:		12.09.97														
ESC		↓														
4. Set the time according to your local clock	↓ soft key	<table border="1"> <tr><td>SETUP</td><td>DEVICE</td><td>CLOCK</td></tr> <tr><td>Time:</td><td></td><td>11.12.42</td></tr> <tr><td>Date:</td><td></td><td>13.03.00</td></tr> <tr><td><<</td><td>< ^ </td><td></td></tr> </table>	SETUP	DEVICE	CLOCK	Time:		11.12.42	Date:		13.03.00	<<	< ^			
SETUP	DEVICE	CLOCK														
Time:		11.12.42														
Date:		13.03.00														
<<	< ^															
5. Enter the date	1 3 . 0 3 . 3 0															
6. Store the date	↓ soft key															
7. Enter other data, if desired	← v ^ → soft keys															
8. Exit Setup menu	← ← soft key															

Configuration

Setting the Balance Functions (BAL.FUNC.)

Purpose

This menu item enables you to configure the balance functions, i.e., to meet individual requirements by selecting predefined parameters in the Setup menu. You can block access to the menu by assigning a password.

Features

The balance functions are combined in the following groups (1st menu level):

- Calibration/adjustment
- Adapt filter
- Application filter
- Stability range
- Taring
- Auto zero
- Weight unit 1
- Tare/zero at power on
- Factory settings: **only wsh. param.** (only the balance functions)

Factory Settings

Parameters: The factory settings are identified by the symbol "o" in the list starting on the next page.

Preparation

Show available balance functions:

- Select Setup menu: press the **Setup** key
- > SETUP is displayed

SETUP	APPLICATION
Application 1	=> Torsile wt. units
Application 2	Counting
Application 3	Percent weigh.
Extra func. (F4)	Animal weigh.
Extra func. (F5)	Calc.: density
<< Menu	

- Select "Balance/scale functions": press the **➤** soft key
- If you already assigned a password:
 - > The password prompt is displayed
- If access is blocked by a password: enter the password using the numeric/alphanumeric keys.
- If the last character of the password is a letter: conclude input by pressing **ABC**
- Confirm your password and have the balance functions displayed: Press the **↵** soft key.
- > Balance functions are displayed:

SETUP	BAL.FUNC.
Calibration/adjustment	
Adapt filter	
Application filter	
Stability range	
Taring	
<< < > >>	

- To select the next group: press the **↵** soft key (down arrow)
- To select the previous item of a group: press the **↶** soft key (up arrow)
- To select the next sub-item within a group: press the **➤** soft key (right arrow)
- To select the previous group: press the **◀** soft key (left arrow)
- To confirm: press the **↵** soft key

Extra Functions

- Exit the Setup menu: press the **◀◀** soft key
- > Restart your application
- Print parameter settings:
 - When the balance functions are displayed, press **Print**
- > Printout (example)

Texts with more than 20 characters are cut off

```

SETUP
  BAL.FUNC.
-----
Calibration/adjustm
  CAL/iso TST key fun
  Internal cal./adju
  Cal/adjustm seq
Cal. with adjustm au
-
  isoCAL-function
                                Off
  Start autom. adju
                                isoCAL
  Print GLP/GMP adju
Automatic if GLP is
selected
  Parameter for exte
  Wt. ID (W ID):

  Cal./adjust.-wt:
                                5000.00 g
Adapt filter
  Normal vibration
Application filter
  Filling mode
Stability range
  2 digits
Taring
  After stability
Auto zero
                                Off
  Weight unit 1
                                Grams /g
  
```

etc.

Balance Functions (Overview)

- o factory setting
- √ user-defined setting(s)

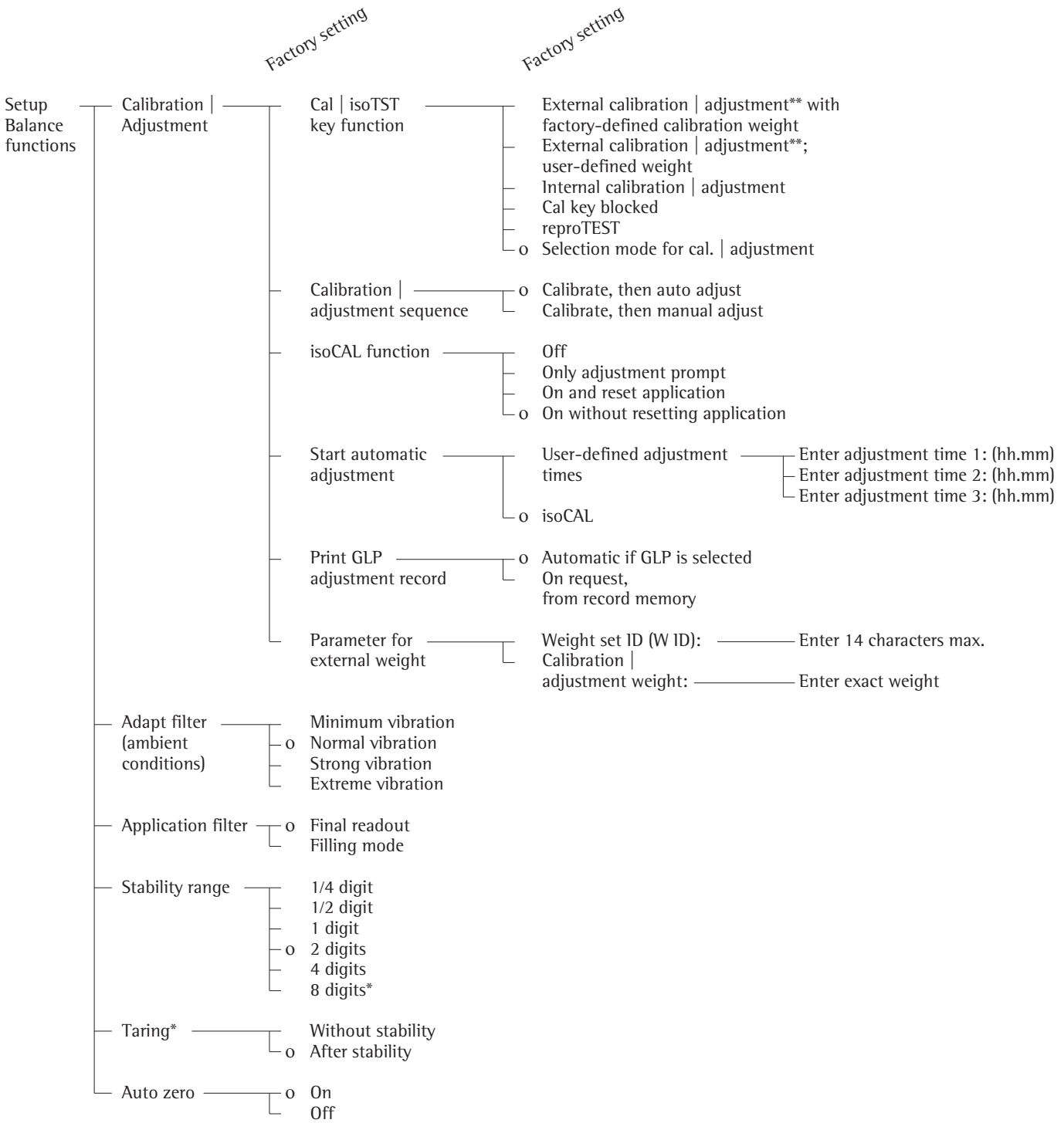

* = not applicable to verified balances

** = only external calibration is possible for verified balances

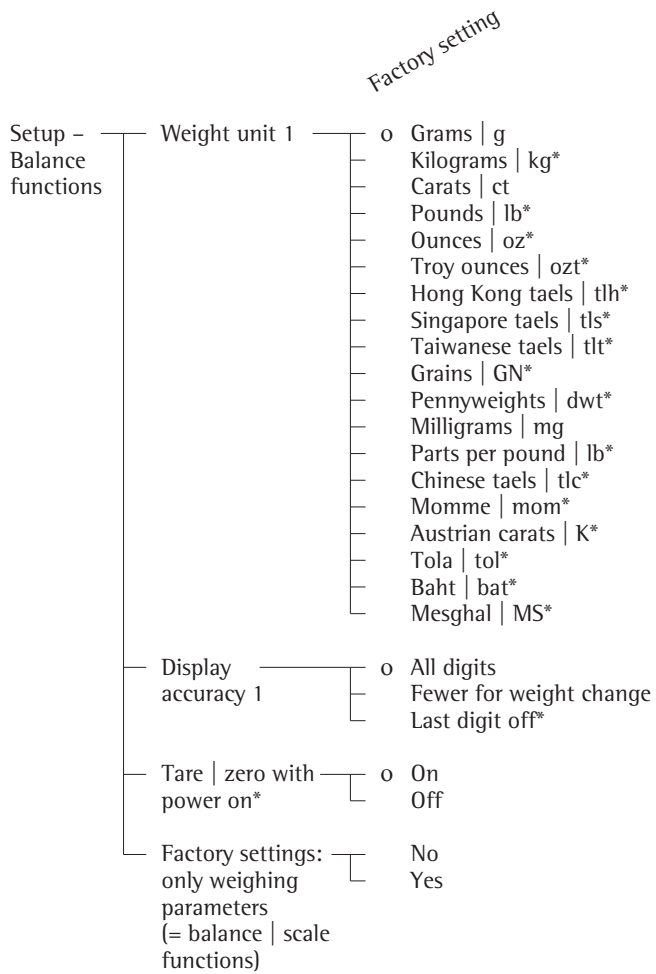

* = not applicable to verified balances

Setting the Device Parameters (DEVICE)

Purpose

This menu item enables you to configure the balance to meet individual requirements by selecting predefined menu parameters in the Setup menu. You can block access to the menu by assigning a password.

Features

The device parameters are combined in the following groups (1st menu level):

- Password
- User ID
- Clock
- Interfaces
- Display
- Keys
- Extra functions
- Factory settings: only device parameters

Factory Settings

Parameters: The factory settings are identified by the symbol "o" in the list starting on the page after next.

Preparation

Display available device parameters

- Select the Setup menu: press **Setup**
- > SETUP is displayed:

SETUP
Balance/scale functions
Device parameters
Application parameters
Printout
Info
<< < > >>

- Select "Device parameters": use the **↓** and **→** soft keys

If no password has been assigned, anyone can access the Setup menu device parameters

If a password has already been assigned:

- > The password prompt is displayed
- If access is blocked by a password: enter the password using the numeric and/or alphabetic keys
- If the last character of the password is a letter: conclude input by pressing the **ABC** key

- Press **↓** to confirm the password

> Device parameters are now displayed:

SETUP	DEVICE
Password	
User ID	
Clock	
Interfaces	
Display	
<< < > >>	

- To select the next group: press the **↓** soft key (down arrow)
- To select the previous menu item of a group: press **↑** soft key (up arrow)
- To select the next sub-item within a group: press the **→** soft key (right arrow)
- To select the previous group: press the **←** soft key (left arrow)
- Press **↓** soft key to confirm the selected menu item

Entering or Changing a Password

- Let's assume that a password with 8 characters max. has already been assigned to access the Setup device parameters

- Select the Setup menu: press

> SETUP is displayed

- Select parameters: Use the **↓** and **→** soft keys

> The password prompt is displayed:

SETUP	PRINTOUT
Application-defined output	
Automatic output of displayed value	
Output to interface ports	
Line format	
ISO/GLP/GMP printout	
<< < > >>	

- Enter the password
- Press the **↓** soft key to confirm your password and view the device parameters
- Write down your password here for easy reference:
Password =
If you assign a password and then forget what the word is:

- Enter the General Password (see Appendix)



- Press the **↓** soft key to confirm and display the password

> The parameters are displayed



- Select the device parameter "Password": If necessary, repeatedly press **↓** or **↑**, until you see

> **Password:** and any existing password

SETUP	PRINTOUT	APPLICATION
Stability parameter		
Print on request then tare		
Auto print upon initialization		
Configured printout		
<< < > >>		

- New password: Enter the numbers and/or letters for the new password (8 characters max.)
If “none” is displayed, this means no password has been assigned to delete the user password: Press  and confirm
- To confirm: press the  soft key
- Exit the Setup menu:
press the  soft key
- > Restart the application

Extra Functions

- Exit the Setup menu:
press the  soft key
- > Restart the application
- Print the parameter settings:
 - If the device parameters are displayed:
press 
- > Printout (example)

```

SETUP
      DEVICE
-----
User ID
  User ID:

Interfaces
  Serial communicati
  SBI
    Baud rate
      1200 baud
    Number of data b
      7 data bits
    Parity
      Odd
    Number of stop b
      1 stop bit
    Handshake-mode
  Hardware handshake
  after 1 char
  Function external
    Print key
  Function control
    Output

Display
  Contrast
      2
  Background
      White
  Digit size
  10mm + bar graph
+text display
  Application symbo
      On

Keys
  CF function in ap
  Clear all applicati
  CF function for i
  Delete last charact
  Block key functio
  All keys unblocke

```

etc.

Setup –
Device
parameters

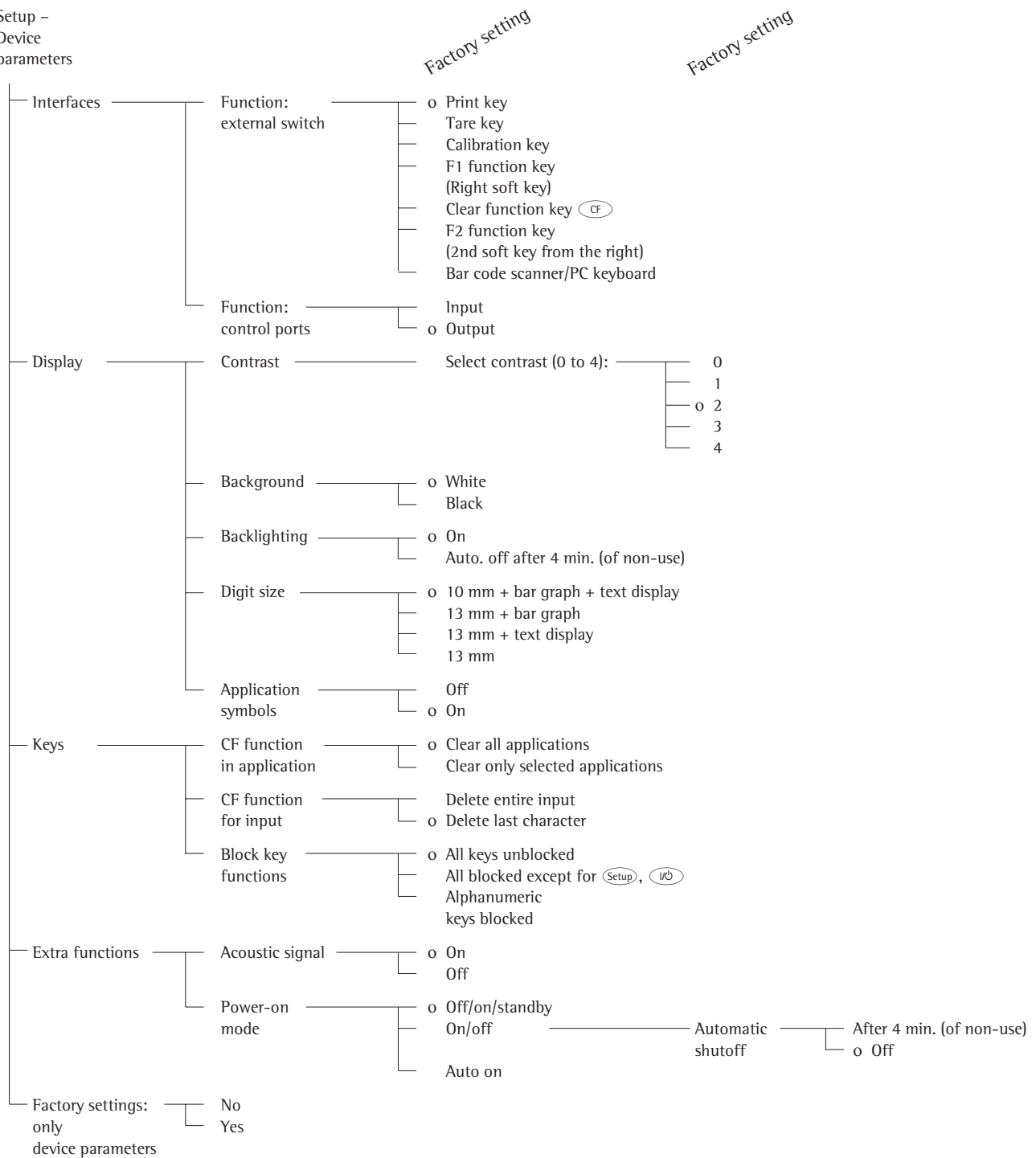

Setting the Application Parameters (Application)

Purpose

This menu item enables you to configure the balance, i.e., adapt the balance to your individual requirements by selecting from a list of parameter options in a menu. You can block access to this menu by assigning a password.

Features

The simple weighing function is available at all times. You can select one from each of the following application groups. This means a number of combinations are possible.

Application 1 (basic settings)

- Toggle weight units
- Counting
- Weighing in percent
- Animal weighing (averaging)
- Calculation
- Recalculation
- Density determination
- Differential weighing
- Air buoyancy correction and air density determination
- Diameter determination

Application 2 (control functions)

- Checkweighing
- Time-controlled functions

Application 3 (data records)

- Totalizing
- Formulation
- Statistics

In addition, you can assign 2 extra functions to each of the soft keys, in some cases (depending on the Setup configuration):

- Second tare memory
- Identification codes
- Manual storage in app. 3 memory (M+ key)
- Product data memory
- SQmin function*
- DKD uncertainty of measurement*

Auto-start application when the balance is switched on

Factory settings:
only application parameters

Factory Settings for the Parameters

The factory settings are identified by the symbol "o" in the list starting on page 23.

Preparation

Display available application parameters:

- Select the Setup menu:
press the (Setup) key
- > SETUP is displayed

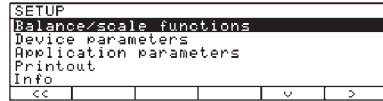

- Select parameters: repeatedly press the \downarrow and \rightarrow soft keys

If you have already assigned a password:

- > The password prompt is displayed:
- If access is blocked by a password: enter the password using the numeric/alphanumeric keys
- If the last character of the password is a letter: conclude input by pressing (ABC)
- Confirm your password and have the application parameters displayed: press the \downarrow soft key

- > The application menu is displayed:

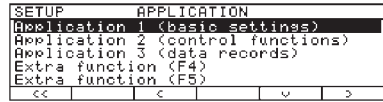

- To select the next group: press the \downarrow soft key (down arrow)
- To select the previous item of a group: press the \uparrow soft key (up arrow)
- To select the next sub-item within a group: press the \rightarrow soft key (right arrow)
- To select the previous group: press the \leftarrow soft key (left arrow)
- To confirm: press the \downarrow soft key

Extra Functions

- Exit the Setup menu:
press the $\leftarrow \leftarrow$ soft key
- > Restart your application
- Print parameter settings:
 - When the balance/scale functions are displayed, press (Print)
- > Printout (example)
Texts with more than 20 characters are truncated

SETUP

Application

```
-----  
Application 1 (basic settings)      Off  
Application 2 (control functions)   Off  
Application 3 (data records)        Off  
Extra function (F4)                  Off  
Extra function (F5)                  Off  
Auto-start app. when switched on    Off  
-----
```

* must be activated by service technician

Application Parameters (Overview)

- o factory settings
- √ user-defined setting(s)

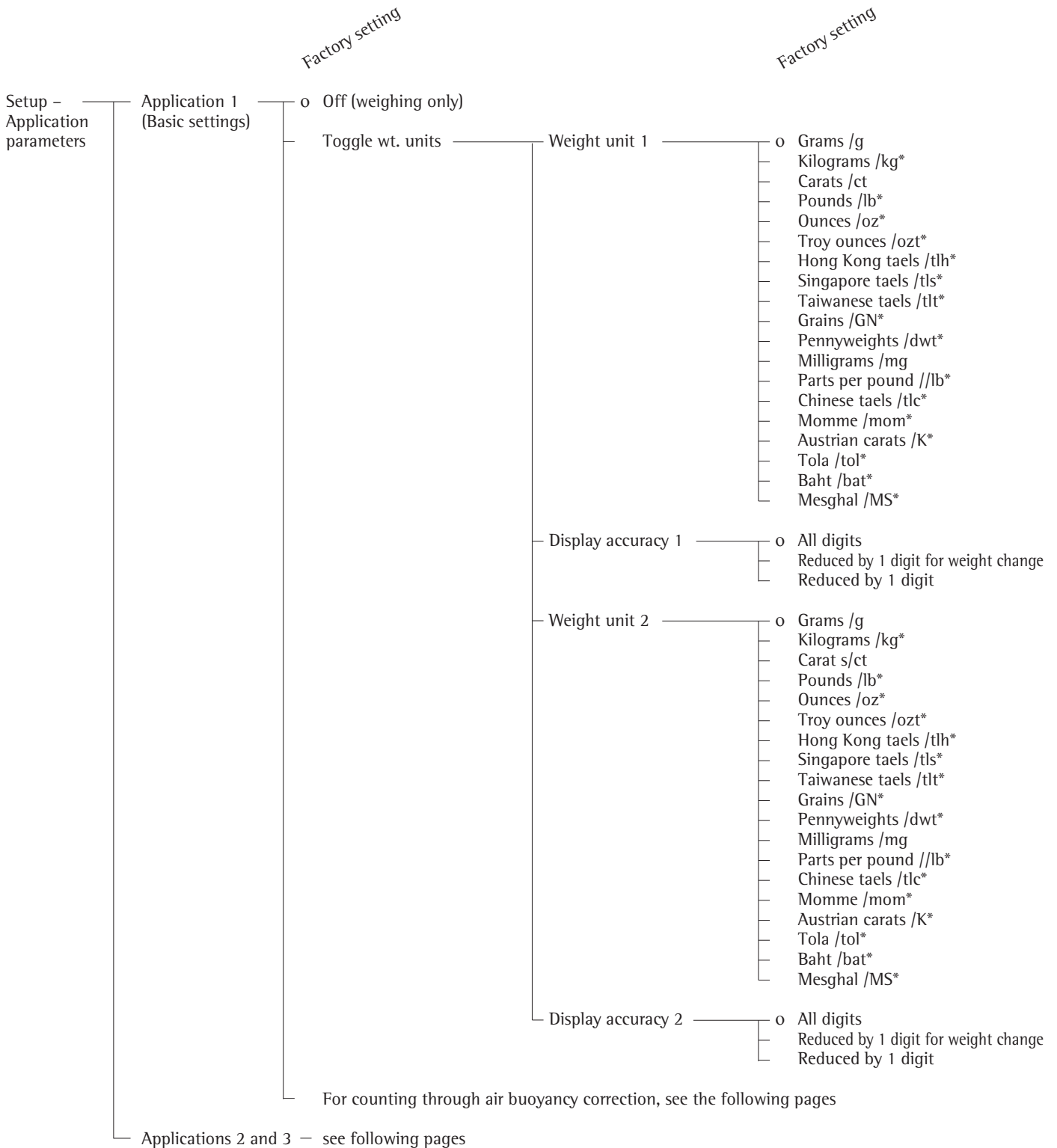

* not applicable to verified balances

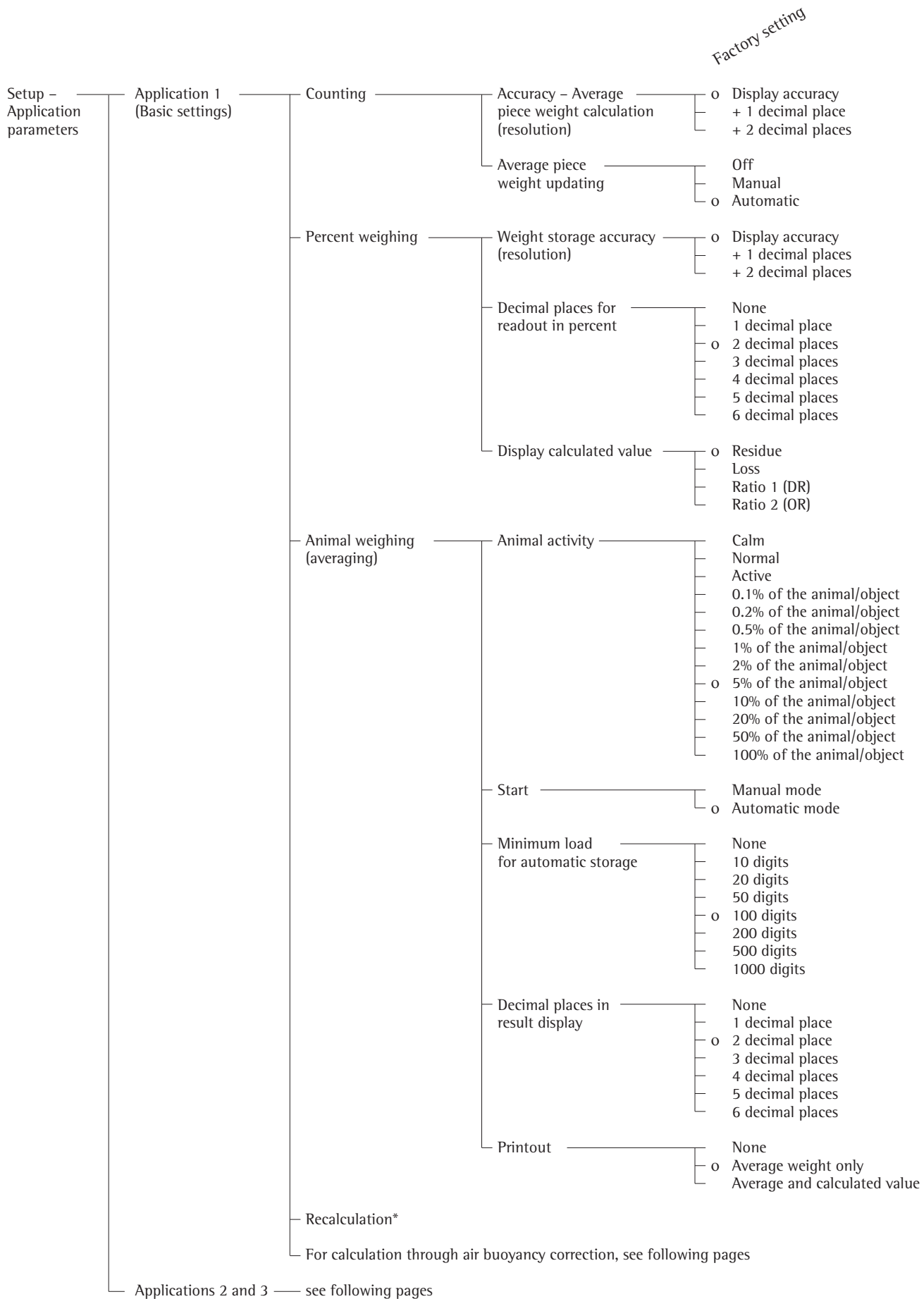

* = How to run this application is described in detail in our Factory “FC...” Installation and Operating Instructions. Request your copy directly from Sartorius or download it from the Internet (www.sartorius.com; see “download”)

Factory setting

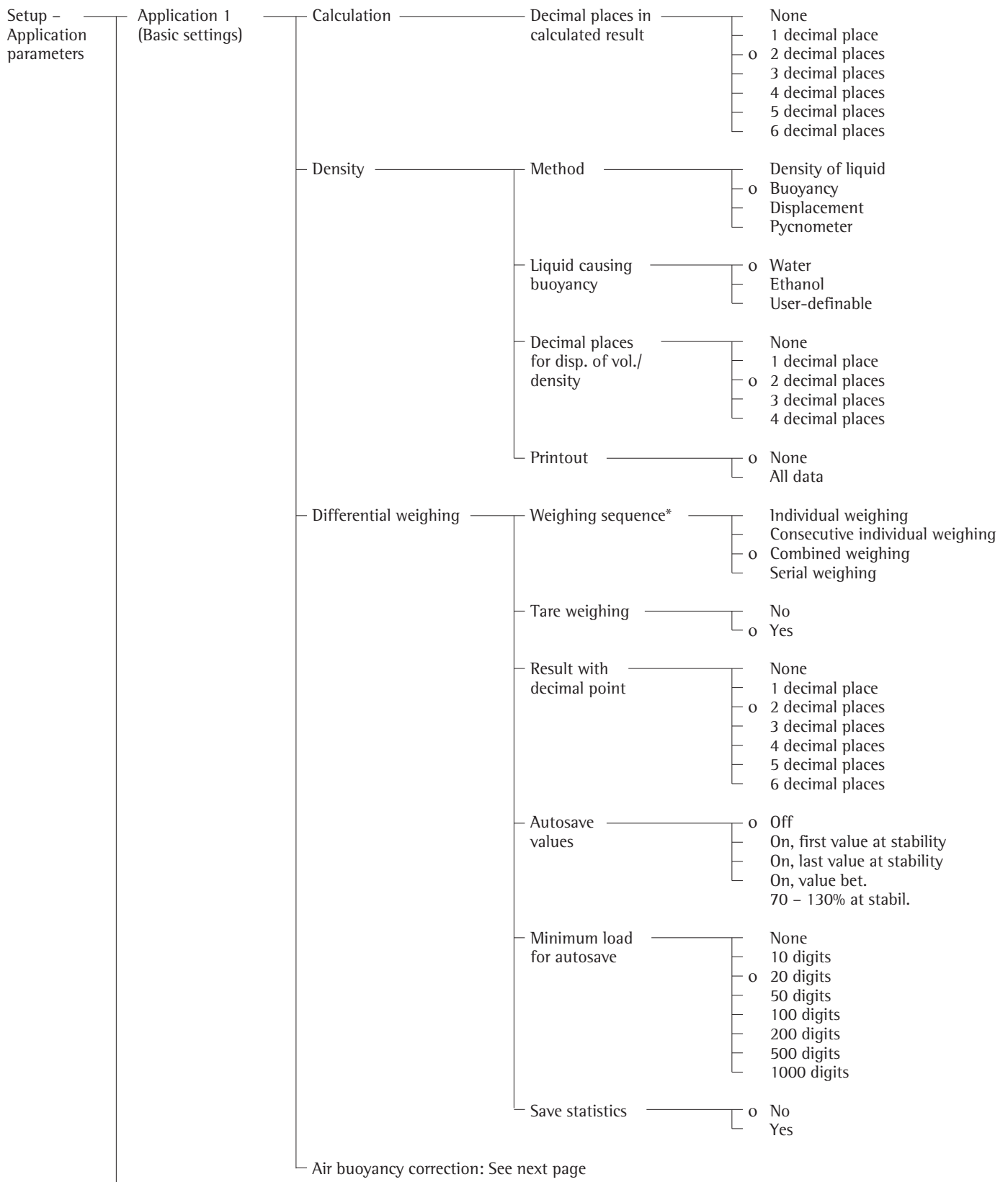

Air buoyancy correction: See next page

Applications 2 and 3: see following pages

* = Setting can only be changed when the program is initially run and when the **Wgt. Setup** key option is set to "No"

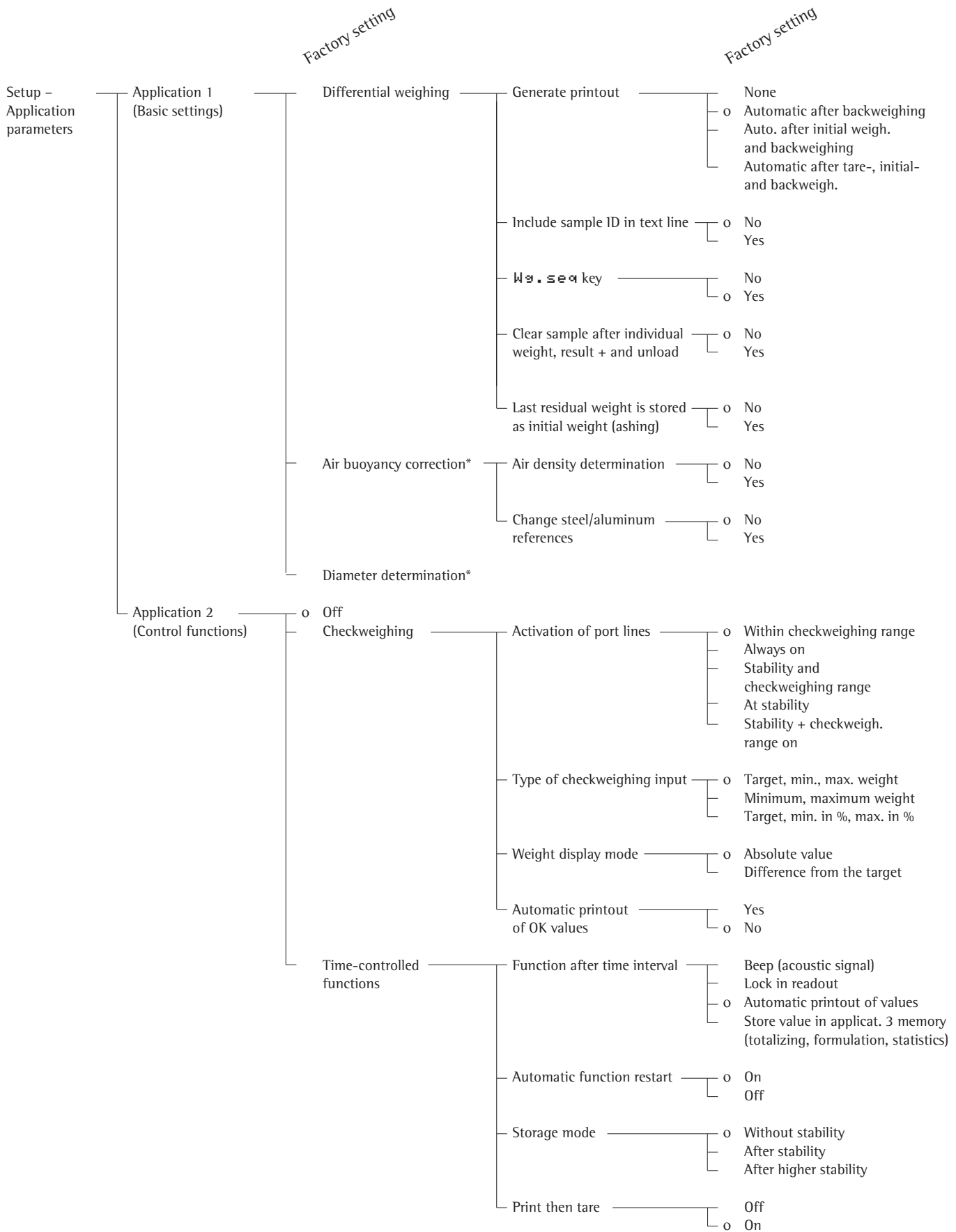

* = How to run this application is described in detail in our Genius “ME” Installation and Operating Instructions. Request your copy directly from Sartorius or download it from the Internet (www.sartorius.com; see “download”)

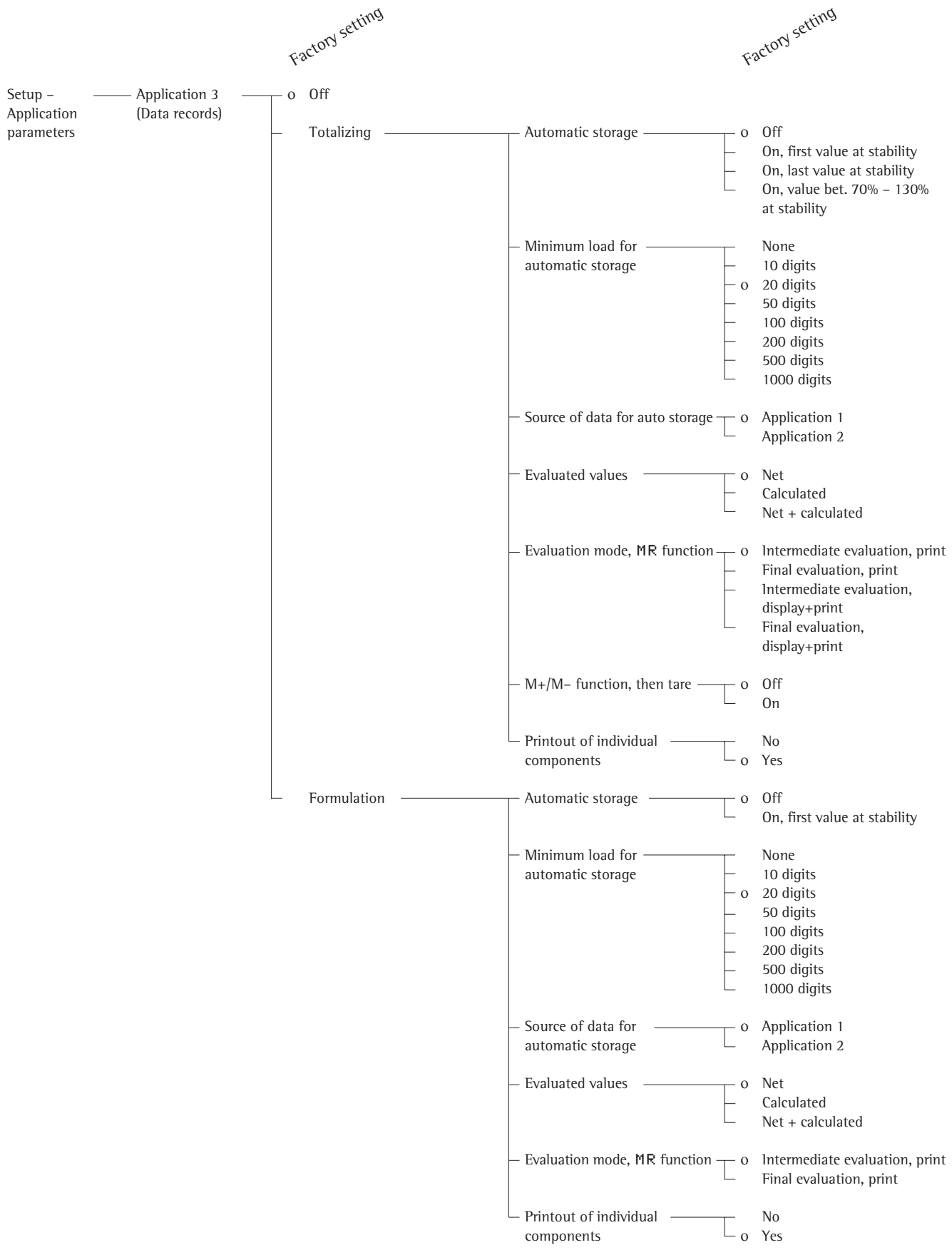

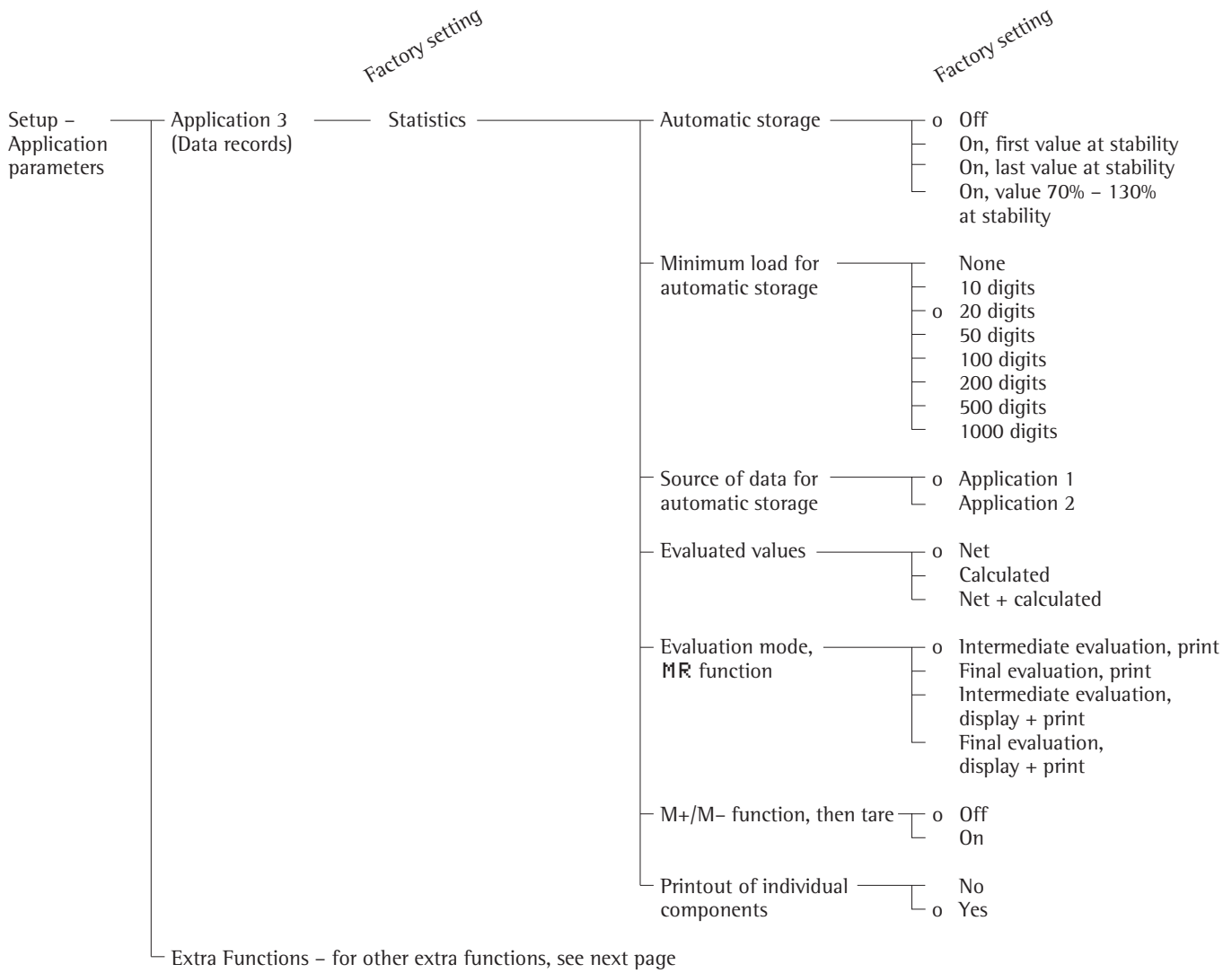

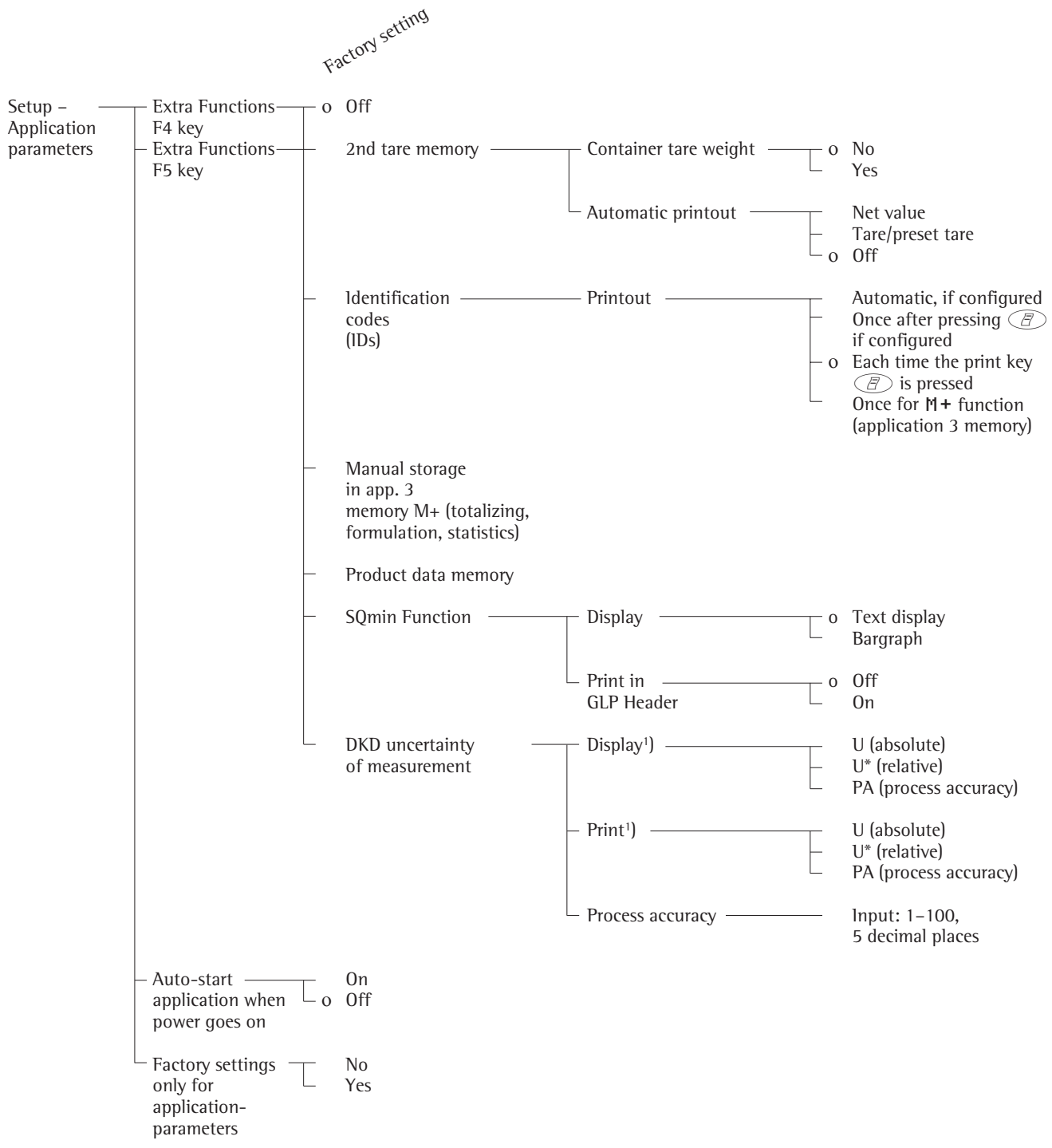

¹⁾ an asterisk (*) indicates an activated menu item. You can select up to 3 items.

Selecting the Printout Function (PRINTOUT)

Purpose

This menu item enables you to configure the printout to meet your individual requirements by selecting predefined menu parameters in the Setup menu. Printouts of weights and other measured or calculated values and IDs enable you to document your data. You can select the particular data you wish to print. To prevent changes to your settings, you can block access to the menu by assigning a password.

Features

The device parameters are combined in the following groups (1st menu level):

- Application-defined output
 - Configured printout
 - FlexPrint
- Automatic output of displayed values
- Output to interface port
- Line format
- ISO/GLP/GMP printout
- Identification (identifier)
- Factory settings – printout only

Factory Settings

Parameters: The factory settings are identified by the symbol “o” in the list on the next page.

Preparation

Display available printout parameters

- Select the Setup menu: press **Setup**
- > SETUP is displayed:

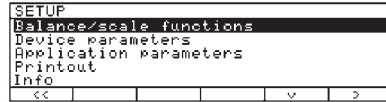

- Select “Printout”: use the **↓** and **→** soft keys

If no password has been assigned, anyone can access the printout parameters in the Setup menu

If a password has already been assigned:
> The password prompt is displayed

- If access is blocked by a password: enter the password using the numeric and/or alphabetic keys
- If the last character of the password is a letter: conclude input by pressing the **ABC** key

- Press **↓** to confirm the password

> Printout parameters are now displayed:

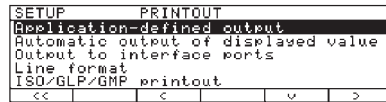

- To select the next group: press the **↓** soft key (down arrow)
- To select the previous item of a group: press the **↑** soft key (up arrow)
- To select the next sub-item within a group: press the **→** soft key (right arrow)
- To select the previous group: press the **←** soft key (left arrow)
- To confirm: press the **↓** soft key

Extra Functions

- Exit the Setup menu: press the **←←** soft key

> Restart your application

- Print parameter settings:
 - When the printout parameters are displayed, press **Print**

> Printout (Example)

```

SETUP          PRINTOUT
-----
Application defined
Stability paramete
With Stability
Print on request t
                Off
Auto print upon in
All values
Configured printou
Indiv.: Printout
Comp.: Printout
Total: Printout
FlexPrint
                                Off
Automatic Output of
Stability paramet
Without stabili
Stop auto print
Not possible
Time-dependent aut
1 display update
Output to interface
Serial communicat:
Application-defined
output
Line format
For other apps/GLP
(22 characters)
ISO/GLP/GMP printou
                                Off
Identification
Lot (L ID):
ID1:
                                ID1
etc.
    
```

Configuration

Printout Parameters (Overview)

- o factory setting
- √ user-defined setting

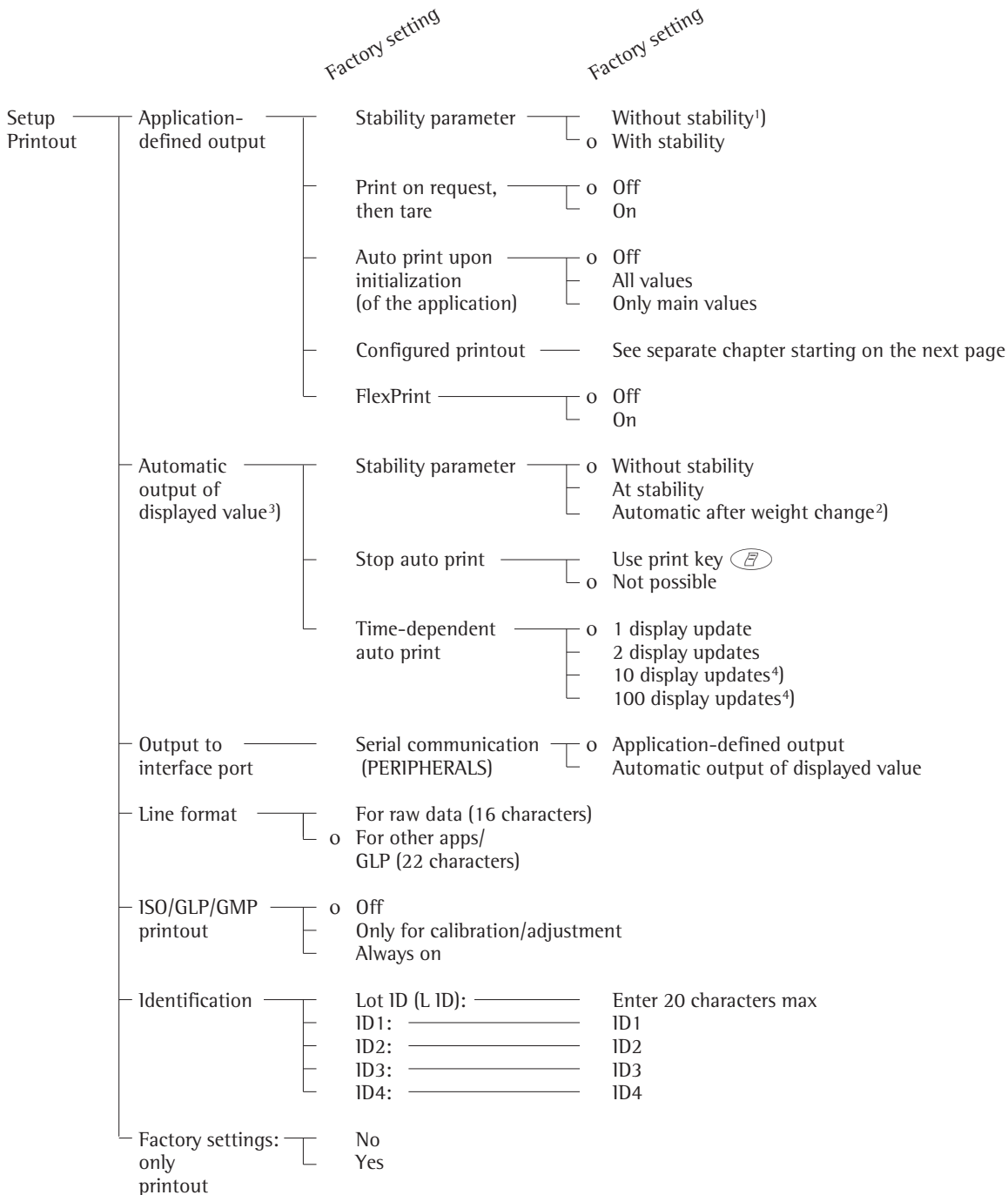

¹⁾ = when the balance is used in legal metrology, this setting may be configured for control purposes only; printout of values is not permitted
²⁾ = Autoprint when load change is >10 d and stability is reached: no printout until residual difference in load value > 5 d
³⁾ = to enable automatic output of the displayed value, the corresponding option (“Automatic output of displayed value” must be activated here, under “Stability parameter”
⁴⁾ = These settings may not be changed on verified balances





Printout Configuration

Purpose

This menu item enables you to configure individual printout formats. With the formulation, totalizing and statistics application, you can also define the values to be included on the total printout when the MR key is pressed.

Under "Setup > Printout > Application-defined output > Configured printout", you can configure individual, component or total data records that contain the items in each application that are available for printouts. Configure these printouts after you have configured the applications, because some entries in the data record depend on the particular application.

Features

- Maximum items in a data record: 60
 - Separate configuration of printout formats for individual weights, components, total, backweighing and statistics
 - Individual printout generation: press the  key
 - Automatic printout of application data: e.g., results from animal weighing or density application (Setup menu: Application 1: Density: Printout: All data) OK values from checkweighing application, time-controlled printouts, 2nd tare memory
 - Component printout: For results from totalizing, formulation or statistics applications, press **M+** or **M-** (Setup: Application 3: ..., Printout of individual components: On)
 - Total printout: For totalizing, formulation or statistics applications, press **MR**
 - Backweighing printouts or records: automatically generated after backweighing or manually by pressing the  key when the result is displayed at the end of backweighing
 - Statistics printout or output: To generate, press the  key when the statistics are displayed
- Printouts for Differential Weighing: These printouts can be generated as standard or configured (user-defined) reports.
- You can configure the following printouts:
- Individual printout
 - Backweighing printout
 - Statistics printouts
- Printouts are generated in one of two ways:
- at the request of the user by pressing the  key (print on request)
 - automatically, if configured in the Setup menu [Application parameters: Application 1: Differential weighing: Generate printout: Auto]

You can turn off automatic printout generation in the Setup menu [Application parameters: Application 1: Differential weighing: Generate printout: None]

- Data records are deleted after you have switched to a different application or activated or de-activated an extra function in the application parameters of the Setup menu
- A new pick list for a data record is created based on the currently active application programs and extra functions
- Printout items can be deleted individually
- No printout is generated when the following setting is configured: Setup: Printout: Line format: For raw data (16 characters)
- Print item "Form feed" for footer: Advance to beginning of next label in the "YDP011S-Label" and "YDP021S-Label" [printer] interface mode

Extra Functions

- Exit printout configuration: press **<<** soft key
- > Restart application
 - Printing "Select" and "List" Settings
 - **LIST**: print the currently selected list
 - **SELECT**: printout items that can still be selected
- When the select bar is on **LIST** or **SELECT**: press the  key
- > Printout (Example)

```
BACKW. PRINT.LIST
=====
Sample date
Net initial wt.
Backweighed res
Loss in %
=====
etc.
```

Example:

Configure an Individual Printout for Counting Application to Include Dotted Line, Date/Time, Piece Count and Net Weight

Settings (changes in the factory settings required for this example):

Setup: Application parameters: Application 1: Counting

Exit the Setup menu: press the << soft key

Then call Setup again: Printout: Application-defined output: Configured printout

Step	Press key(s) (or follow instructions)	Display/Output
1. Select Setup menu, then "Printout"	(Setup), then v repeatedly and > soft key	<pre> SETUP PRINTOUT Application-defined output Automatic output of displayed value Output to interface ports Line format ISO/GLP/GMP printout << < v > </pre>
2. Confirm "Application-defined output"	> soft key	<pre> SETUP PRINTOUT APPLICATION Stability parameter Print on request then tare Auto print upon initialization Configured printout << < v > </pre>
3. Select and confirm "Configured printout"	v soft key 3x and > soft key	<pre> PRINTOUT APPLICATION CONFIG Indiv.: Printout f. app./weighing << < > </pre>
4. Confirm "Indiv. printout"	> soft key	<pre> LIST INDIU.PRT SELECTION Blank line Form feed Date/time Time << Delete > </pre>
5. Select "Blank line"	>, v, j soft keys	<pre> LIST INDIU.PRT SELECTION Blank line Form feed Date/time Time << < ^ v j </pre>
6. Select "Date/time"	v soft key twice, then j soft key	<pre> LIST INDIU.PRT SELECTION Date/time Blank line Form feed Time GLP header << < ^ v j </pre>
7. Select "Piece count"	v soft key repeatedly, then j soft key	<pre> LIST INDIU.PRT SELECTION Date/time Net (N) Gross (G#) Ref. quantity Ref. weight Target << < ^ v j </pre>
8. Select "Net (N)"	^ soft key repeatedly, then j soft key	<pre> LIST INDIU.PRT SELECTION Date/time ID1 ID2 ID3 ID4 Net (N) Gross (G#) << < ^ v j </pre>
9. Exit "Printout" configuration	<< soft key	
10. Perform weighing operations, then print	(E)	<pre> ----- 14.01.2000 09:19 Qnt + 598 pcs N + 2003.13 g </pre>

Device Information

Purpose

This menu item enables you to have information displayed about the specific balance ("device"), as well as "FlexPrint" information.

Displaying Device Information

- Select the Setup menu:
press the **Setup** key

> "SETUP" is displayed:

SETUP
Balance/scale functions
Device parameters
Application parameters
Printout
Info
<< >>

- Select "Info":
Repeatedly press the **↵** soft key, then press the **➤** soft key

> Device information is displayed:

SETUP	INFO
Version no.:	01-35-18
Bal. ver. no.:	00-20-12
Model:	LA5200P
Serial no.:	70906913
<< >>	

- Print device information:
Press the **Print** key

> Printout (Example)

```
-----
23.02.2000      13:02
Model          LA5200P
Ser. no.       91205355
Vers. no.      01-35-18
               (Version of the operating program)
ID             BECKER123
               (User-ID)
-----
```

```
-----
SETUP          INFO
               DEVICE
-----
Version-no.:   01-35-18
               (Version of the operating program)
Wgh. sys. vers: 00-20-12
               (Version no. of the weighing cell)
Model:         LA5200P
Serial no.:    91205355
Next mainten.: 01.01.2004
Service phone: 00495513080
SQmin:         100.00 g
-----
```

- Return to SETUP overview:
press the **←** soft key
 - Exit Setup menu:
press the **←←** soft key
- > Original settings are restored

Factory Settings

Each parameter category has a factory setting. In the Setup menu, you can restore all factory settings by confirming the selection **YES**.

The following settings are not restored:

- Language
- Password
- Display contrast
- Time (clock)

Display Flexprint Information

- Select the Setup menu:
press the **Setup** key

> "SETUP" is displayed:

SETUP
Balance/scale functions
Device parameters
Application parameters
Printout
Info
<< >>

- Select "Info":
press the **↵** soft key repeatedly and then the **➤** soft key

SETUP	INFO
Device information	
FlexInfo	
<< >>	

- Select "FlexInfo":
press the **↵** soft key and then the **➤** soft key

> The FlexPrint information is displayed, with print instruction file name, software ID and version number:

SETUP	INFO	FLEXINFO
PDIRECT	ID---	V.---
PGMPFOOT	ID403	V.000001
PGMPHEAD	ID403	V.000001
<< >>		

- To select a particular print file name with software ID (for example, ID403), if desired:
press key **↵** or **↶** as required
- > If the display shows **ID---** :
The weight block for legal metrology is not printed by this print file.
- > Display of version number:
U. xx. xx. xx
Created by Sartorius:
U. S. xx. xx. xx
- Return to SETUP overview:
press the **←** soft key
 - Exit Setup menu:
press the **←←** soft key
- > The device returns to the previous mode

Operation

Basic Weighing Function

Purpose

The basic weighing function is always accessible and can be used alone or in combination with an application program (Toggle between Weight Units, Counting, Weighing in Percent, etc.).

Features

- Taring the balance
- Assigning IDs to weights
- Printing weights
- Printing ID codes for weights

Factory Settings

Tare: `After stability`

Manual/auto print mode:

`Manual with stability`

Line format:

`For other apps/GLP
(22 characters)`

Soft Key Functions

`cal` Initiate calibration/
adjustment routine

`isoCAL` Press to start isoCAL
routine

`S ID` Store ID entered

Below-Balance Weighing

A port for a below-balance weighing hanger is located on the bottom of the balance.

Balances with a capacity ≤ 12 kg:

- Open cover plate (1) on the bottom of the balance

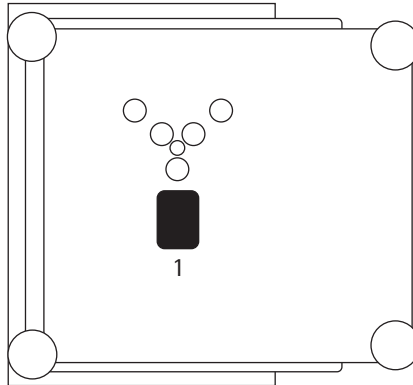

- Attach the sample (e.g., using a suspension wire) to the hook (2).

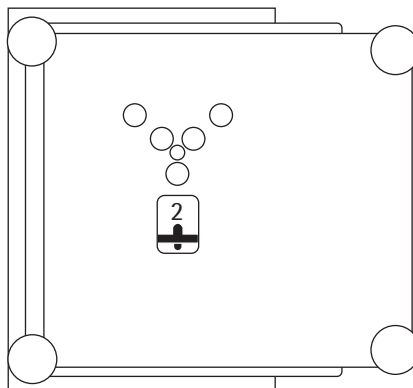

- If necessary, install a shield for protection against drafts

Balances with a weighing capacity ≥ 16 kg:

- Use a screwdriver to open the cover plate on the bottom of the balance

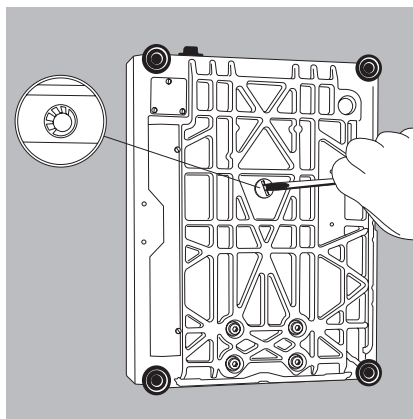

- Attach the hook ordered directly from Sartorius

- If necessary, install a shield for protection against drafts

Important Note Concerning Verified Balances Approved for Use as Legal Measuring Instruments in the EU*: The below-balance weighing port may not be opened or used when an approved balance is being operated as a legal measuring instrument.

Preparation

- Turn on the balance:
Press

> The Sartorius logo is displayed

- If it is time for the next maintenance, the following appears:

NEXT MAINTENANCE:	
Date:	01.01.2005
Service phone:	00495513080
<< >>	

To exit this screen: press the << soft key

- Call your nearest Sartorius Service Center to schedule a maintenance appointment

- To tare the balance, if desired:
Press

> The symbol is displayed when a verified balance is tared or zeroed (± 0.25 digits).

Important Note Concerning Verified Balances Approved for Use as Legal Measuring Instruments in the EU*: The type-approval certificate for verification applies only to non-automatic weighing instruments; for automatic operation with or without auxiliary measuring devices, you must comply with the regulations of your country applicable to the place of installation of your balance.

- The temperature range indicated on the verification ID label must not be exceeded during operation

Example:

MD BF 100

0...+40 °C

* including the Signatories of the Agreement on the European Economic Area

Additional Functions

In addition to the functions:

- alphanumeric input
- taring (not during alphanumeric input)
- printing

you can also access the following functions from the weighing application:

- calibration (not during alphanumeric input)
- setup
- turning off the balance

Calibration
● Press **Cal**

- > See the section on “Calibration/Adjustment” for further instructions.

Important Note Concerning Verified Balances of Accuracy Class **1**:

To avoid measuring errors, the respective air density must be allowed for. The following formula is used to calculate the mass of the sample:

$$m = n_w \frac{1 - \rho_L/8000 \text{ kg m}^{-3}}{1 - \rho_L/\rho}$$

m = mass of the sample

n_w = weight readout

ρ_L = air density during weighing

ρ = density of the sample

Practical Examples

Example W1: Simple weighing

Step	Key (or instruction)	Display/Output
1. If necessary, tare the balance (0 symbol: balance is tared, - verified balances only)	Tare	
2. Enter sample ID	see Example W2	
3. Determine sample weight (Example)	Place load on balance	
4. Print weight value	Print	<pre>S ID ABC123 N + 2231.56 g</pre>

Example W2
Enter "ABC123" as sample ID

Note:

- The sample ID generally applies to one weighing operation only
- The ID is deleted after data output

Step	Key (or instruction)	Display/Output
Initial status (balance unloaded) (ID can also be entered while balance is loaded)		
1. Select alphabetic input	ABC	
2. Select the required letter group	ABCDEF soft key	
3. Enter the letter "A" (To delete a letter:	A soft key CF)	
4. Select the letter group and enter "B"	ABCDEF soft key B soft key	
5. Select the letter group and enter "C" (If only letters are entered, conclude input:	ABCDEF soft key C soft key ABC)	
6. Enter the numbers 1, 2 and 3	1 2 3	
7. Store the ID (max. 20 characters) - The next printout will include the sample ID	S ID soft key	

Device Parameters

Password

You can enter a password to block access to the operating menu and to the functions for ID code input and exact calibration weight input.

For details, see “Setting the Device Parameters” in the chapter entitled “Configuration”.

User ID

You can enter your own personal password (20 characters max.)

Clock

ISO/GLP/GMP printouts in particular must be generated with the date and time stamp of the specific measurement. This date and time stamp is optional on other printouts.

For details, see “Setting the Device Parameters” in the chapter entitled “Configuration”.

Interface

Purpose

This item enables you to set the parameters for the following interfaces:

- Serial interface port
- External switch function

Serial communications port

You can set the serial communications port to use for the following modes:

- SBI
- XBPI
- YDP01IS
- YDP02
- YDP03
- YDP01IS-Label1
- YDP02IS
- YDP02IS-Label1
- Universal
- YDP04IS
- YDP04IS-Label1

Universal Remote Switch

You can connect an external universal remote switch (foot switch) to one of the two serial ports. Then you can assign one of the following functions to be performed when the switch is activated:

- Print key
 - Tare key
 - Cal key
 - F1 function key
 - CF key
 - F2 function key
 - Bar code scanner, PC keyboard
- (Special adapter necessary/
Order no. YCC01-0024M01)





“PC Keyboard” Functions

The alphanumeric key codes implemented are for a German keyboard layout only (“Z” in the first row instead of “Y”, for example).

Some of alphanumeric keys are used with the [Shift] key:

a-z, A-Z, 0-9, Space, ,, , \ # < > ! " \$ @ % & / ; = : _ ? * ”

Function key:

PC keyboard	Balance
F1	 Tare key
F2	 Setup key
F3	Soft key 6
F4	Soft key 5
F5	Soft key 4
F6	Soft key 3
F7	Soft key 2
F8	Soft key 1
F9	Display
F10	Escape
F11	 key (print)
F12	 key
Return	Soft key 1
Backspace	Escape
Up Cursor	Soft key 3
Left Cursor	Soft key 4
Down Cursor	Soft key 2
Right Cursor	Soft key 1
POS1 (HOME)	Soft key 6
ESC	Escape
PRINT	 key

The “Num Lock” und “Caps Lock” keys are not supported. There is no country-specific option for switching these keys to a different function.



Control Port Function

You can connect either a checkweighing display or an external universal switch to the serial communications port on the balance (factory setting).

To do so, you need to configure the interface for **input** or **output**.

Pin Assignment Chart of the Female Interface Connector

Pin Function: Input

- 15  key; see “Universal switch”
- 16  key
- 17 Soft key 6 (Cal)
- 18 Soft key (F1)
- 19  key

Pin Function: Output

- 15 “External switch” (see above)
- 16 Control port 1: lighter
- 17 Control port 2: equal
- 18 Control port 3: heavier
- 19 Control port 4: “set”

For further information on the pin assignment chart, see the section on “Pin Assignment Charts” in the chapter entitled “Overview”.

Display

You can configure the display for your individual needs.

The contrast can be adjusted in 5 levels:

Contrast

Characters can be displayed in black on white or vice versa: **Background**



You can blank out either the bar graph or the text line or both: **Digit size**

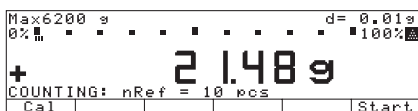

10mm + bar graph + text display

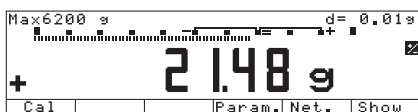

13mm + bar graph

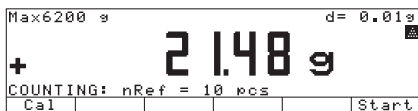

13mm + text display

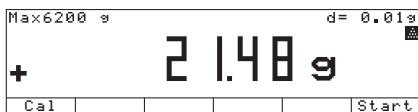

13mm

You can blank out the display of application symbols: **Application symbols**

Keys

You can assign different functions to the **CF** key for deleting input and applications.

When you delete applications, you can delete either the data stored for all applications or just selected data.

CF function in application

When you delete input, you can either delete all the data input in a field, or only the last character entered.

CF function for inputs

You can block key functions; you can choose whether to block all keys (except **MC** and **Setup**), or just the alphanumeric keys.

Block key functions

Extra Functions

Acoustic Signal

An acoustic signal is emitted when you press a key. When the key pressed is allowed, the signal is a single beep-tone; when it is not allowed, this is signaled by a double-beep (key does not initiate a function). In the Setup menu, you can configure whether

- the acoustic signal should sound (**On**)
- the acoustic signal should not sound (**Off**)

Power-On Mode

You can configure the balance so that when a power supply is connected,

- the scale is off (**Off/on/standby** or **Auto on**)
- the scale switches on automatically (**Auto on**)

You can also configure the scale to go into the standby mode (**Off/on/standby**) when it is turned off.

After you turn on the scale, a self-test of the functions is run (**TEST** is displayed in the text line and the bar graph is shown)

MP8 Interface Emulation

Purpose

With the MP8 interface emulation function, you can connect peripheral devices of the MP8 generation that have separate AC power supplies (such as the 73822... Data Control terminal, a YFC..., or a YD1 50 Z Data Input dedicated keyboard, for example) to your LA balance.

Features

- The balance can be used only to determine weights.
- The interface communicates exclusively in the MP8 binary protocol.
- Select the application program and the program index for MP8, as well as individual application parameters, in the Setup menu.

Preparation

- Activate the MP8 emulation mode*:

- Press **Setup**
- Select the **factory settings** and confirm: press the **▼** soft key repeatedly and then the **➤** soft key
- Select **Reset to MP8**: press **▼** soft key and **➤** soft key
- Select **Yes** and press **↓** to confirm
- > The balance is restarted

* follow the same procedure to return from MP8 emulation back to factory setting

Factory Settings

Each parameter category has a factory setting. To restore the factory settings, select this item in the Setup menu and select **YES** to confirm.

The following parameters are not restored to factory settings when you activate this function:

- Language
- Password
- Display contrast
- Time (clock)

Calibration/Adjustment

Purpose

Calibration is the determination of the difference between the weight readout and the true weight (mass) of a sample. Calibration does not entail making any changes within the balance.

Adjustment is the correction of this difference between the measured value displayed and the true weight (mass) of the sample, or the reduction of the difference to an allowable level within maximum permissible error limits.

Available Features

You can configure whether the calibration mode

- will be activated according to the specific setting (external/ internal) or
- can be selected by the user after pressing the Cal soft key: **Selection mode.**

Your balance can be calibrated externally (Balance menu: CAL key function; menu item **Ext. cal./adj.;** **factory-def. wt.** or **Ext. cal./adj.;** **user-defined wt.**) or internally (**Internal cal./adjustment**).

External calibration can be performed

- with a user-defined weight
Ext. cal./adj.;
user-defined wt.

The adjustment can be performed

- automatically following calibration: **Cal., then auto adjust.** or
- if desired, the adjustment operation can be started manually after calibration: **Cal., then manual adjust.**

You can have the balance automatically display an adjustment prompt after a certain time interval has elapsed since the last calibration/adjustment or when the ambient temperature changes by a defined amount.

You can also configure the balance to perform calibration and adjustment automatically (isoCAL) when the pre-set time and/or temperature limit is reached
On and reset applica-
tion and On without
resetting app.

You can have the calibration/adjustment results documented in a ISO/GLP/GMP-compliant printout; see page 116.

Factory Settings

Calibration/adjustment mode:

Selection mode

Calibration/adjustment sequence:

Calibrate, then auto
adjust

isoCAL function (automatic initiation of cal./adj. sequence): **On without**
resetting app.

Start automatic adjustment:

isoCAL

Print GLP/GMP calibration/adjustment record: **Automatic if GLP**
is selected

Releasing Access to External Calibration in Verified Balances of Accuracy Class I

- Remove the covering plate from the back of the balance housing
- Move Switch 1 in the direction of the arrow

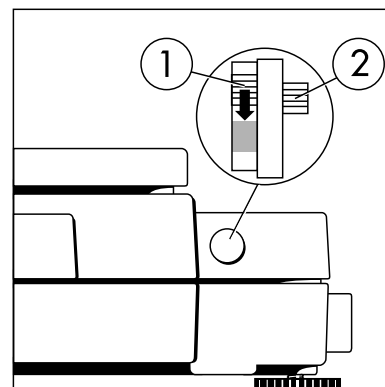

- > Switch down:
external calibration accessible
- Switch up:
external calibration blocked

- > Note:
Do not move Switch 2

For service technicians only: External Calibration in Verified Balances of Accuracy Class II

- External calibration is blocked when the balance is used in legal metrology
- > External calibration can only be released after removing the verification control seal, in which case the validity of the verification becomes void and the balance must be re-verified
- External calibration can now be performed

Preparation

- Select the balance function for “calibration/adjustment”: press **Setup**
- To select the **Balance/scale functions**: press the **➤** soft key
- Select **Calibration/adjustment**: press the **➤** soft key

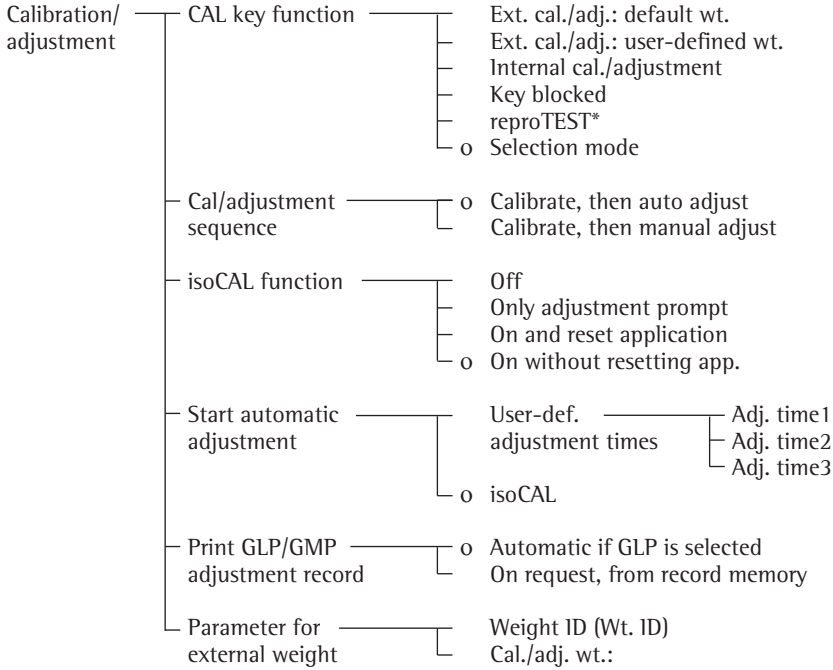

o = factory setting





- Save settings and exit Setup menu: press the **◀◀** soft key

* = How to run this application is described in detail in our “Genius ME” Installation and Operating Instructions. Request your copy directly from Sartorius or download it from the Internet (www.sartorius.com; see “downloads”)

Preparation

Example:

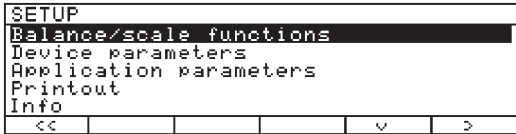
Set the parameters for calibration and adjustment; e.g., with manual calibration/adjustment, isoCAL off

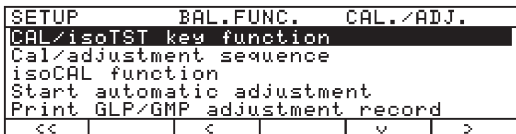
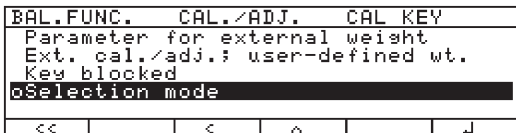
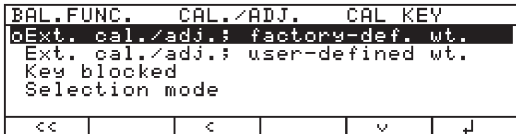
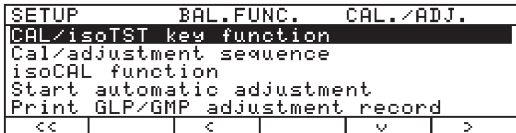
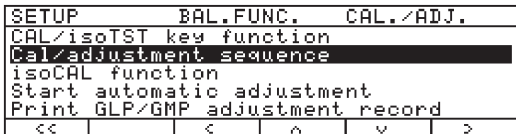
Step	Press key(s) (or follow instructions)	Display/Output
1. Switch on the balance, if not already on		Sartorius logo and self-test 
2. Select the Setup menu		
3. Select "Balance/scale functions"	> soft key	
4. Select "Calibration/adjustment"	> soft key	
5. Select CAL key function	> soft key	 <p>o = last setting selected</p>
6. Select desired function and confirm (e.g., "Internal cal./adj.")	↵ soft key, repeatedly, if necessary ↓ soft key	
7. Exit CAL key function	< soft key	
8. Select "Cal./adjustment sequence"	↵ soft key	

Selecting the Calibration/ Adjustment Parameter





The setting **Selection mode** must be selected in the Setup menu under "Balance functions: Calibration/adjustment: CAL key function" (factory setting).

After pressing the **Cal** soft key, you can choose from among the following settings by pressing the **Select** soft key:

- External calibration/adjustment with the preset calibration weight:
**Ext. cal./adj.;
factory-def. wt.**
 - External calibration/adjustment with a calibration weight determined by the user:
**Ext. cal./adj.;
userdefined wt.**
 - Internal calibration/adjustment
**Internal cal./
adjustment**
 - Reproducibility test
reproTEST
- Start the desired routine:
Press the **Cal** soft key again

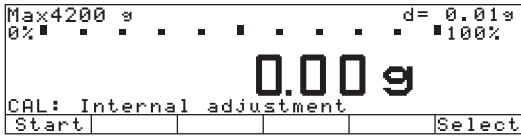
In the selection mode: Perform external calibration followed by automatic adjustment with the factory-set weight

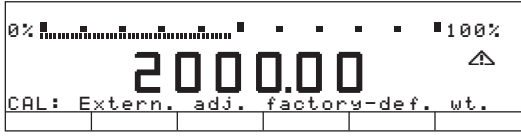
Configuration:
factory settings

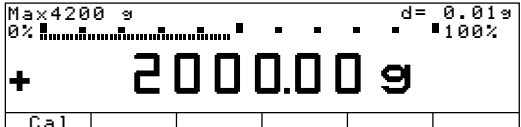
Step	Key(s) (or instruction)	Display/Output
1. Select Calibration	Cal soft key	
2. Select external calibration/adjustment with factory-defined weight	2 x Select soft key	
3. Start external calibration/adjustment	Start soft key	
4. Place the weight on the balance (e.g., 2,000.00 g) Minus sign -: Weight too low Plus sign + Weight too high no plus/minus sign: Weight o.k.	Place weight on balance	
This is displayed after calibration, for approx. 10 seconds: (on verified balances, the difference between the displayed weight and the true weight (mass) is displayed) After adjustment, the following is displayed:		
5. Unload the balance (ISO/GLP/GMP printout: see page 116)		

Internal Calibration/Adjustment

First set either **Internal cal./ adjustment** or **Selection mode** (factory setting) in the Setup menu under “Balance functions: Calibration/adjustment: CAL key function.”

Inside the balance housing is a built-in motorized calibration weight.

The internal calibration/adjustment sequence is as follows:

- Select the calibration function: Press the **Cal** soft key and then the **Start** soft key
- > The internal calibration weight is applied automatically
- > The balance is calibrated
- > If the setting **Calibrate, then auto adjust** is selected in the Balance menu, the balance is now automatically adjusted
- > If the setting **Calibrate, then manual adjust** is selected in the Balance menu, you can end “Internal cal/ adjustment” now; to start it, press the **Start** soft key without adjusting the balance (see “Calibration and Adjustment Sequence”, next column)
- > The internal calibration weight is removed
- > (ISO/GLP/GMP printout: see page 116)

Calibration and Adjustment Sequence

In the Setup menu, you can configure the balance so that:

- calibration is always followed automatically by adjustment **Calibrate, then auto adjust** (factory setting) or
- you have the choice of ending the sequence or starting adjustment after calibration **Calibrate, then manual adjust**
If no deviation is determined in calibration, or the deviation is within the tolerance limits dictated by the degree of accuracy you require, it is not necessary to adjust the balance. In this case, you can end the calibration/adjustment sequence after calibration. There are 2 softkeys active at this point:
 - **Start** to start adjustment
 - **End** to end the sequence

External Calibration/Adjustment* with a User-Defined Calibration Weight

First set either **Ext. cal./adj.:** **user-defined wt.** or **Selection mode** (factory setting) in the Setup menu under "Balance functions: Calibration/adjustment: CAL key function."

You can define a weight for calibration/adjustment. External calibration/adjustment must be performed with weights that are traceable to a national standard and that have error limits which are at least 1/3 of the required tolerance of the display accuracy.





See page 44 for the external calibration/adjustment sequence. For this example, select external calibration/adjustment with a user-defined weight.

The balance has a factory-set weight value (see "Specifications").

To reset a user-defined calibration weight to the original factory setting:

- Enter the factory-defined value manually (see "Specifications")

Define the Calibration Weight

Step	Press key(s) (or follow instructions)	Display/Output
1. Select Setup menu		<pre> SETUP APPLICATION Application 1 => Toggle wt.units Application 2 Counting Application 3 Percent weigh. Extra func. (F4) Animal weigh. Extra func. (F5) Calc., density << Menu v >> </pre>
2. Select "Balance/scale functions"	➤ soft key	<pre> SETUP BAL.FUNC. Calibration/adjustment Adapt filter Application filter Stability range Taring << < v >> </pre>
3. Select "Calibration/adjustment"	➤ soft key	<pre> SETUP BAL.FUNC. CAL./ADJ. CAL/isoTST key function Cal/adjustment sequence isoCAL function Print GLP/GMP adjustment record Parameter for external weight << < v >> </pre>
4. Select parameter for external weight	⏴ soft key 5 × ➤ soft key	<pre> BAL.FUNC. CAL./ADJ. PARAMETER Wt. ID (W ID): 3000 Cal./adj. wt.: 100.00000 g << < v >> </pre>
5. Select "Cal./adj. wt."	⏴ soft key	<pre> BAL.FUNC. CAL./ADJ. PARAMETER Wt. ID (W ID): Cal./adj. wt.: 100.00000 g << < ^ >> </pre>
6. Enter calibration weight (e.g., 5000 g) and save	   	<p>3000 = last setting selected</p> <pre> BAL.FUNC. CAL./ADJ. PARAMETER Wt. ID (W ID): Cal./adj. wt.: 200.00000 g ESC ↓ </pre>
7. Save the calibration weight	⏴ soft key	<pre> BAL.FUNC. CAL./ADJ. PARAMETER Wt. ID (W ID): Cal./adj. wt.: 200.00000 g << < ^ >> </pre>
8. Exit the Setup menu	⏪ soft key	

isoCAL:

Automatic Calibration and Adjustment

First set either **On and reset the application** or **On without resetting the app.** (factory setting) in the Setup menu under "Balance functions: Calibration/adjustment: CAL key function". The "isoCAL" display automatically begins flashing if the ambient temperature changes in relation to the temperature at the time of the last calibration/adjustment, or after a defined time interval has elapsed. The balance is telling you that it wants to adjust itself.

This automatic calibration prompt is triggered when:

- The change in temperature or the elapsed time interval is greater than that shown in the table at the right
- The balance status does not correspond to Setup configurations
- No number or letter input is active
- The load has not been changed within the last 2 minutes
- The balance has not been operated within the last 2 minutes
- The load on the balance does not exceed 2% of the maximum capacity
- When you turn on the balance after it had been disconnected from power (only on verified balances with a readability of ≤0.1 mg)

When these requirements are met, **C** is displayed in the measured value line.

If the balance is not operated and the load is not changed, internal calibration and adjustment starts after 15 seconds have elapsed.

Automatic Calibration and Adjustment at Set Times*

In the Setup menu (see p. 41 for the menu path) you can enter up to three different times of day for automatic calibration/adjustment.

When one of these times is reached, the balance will display the flashing calibration prompt ("isoCAL"). Calibration/adjustment is not performed if the balance is off (standby mode) or in the Setup mode at the time set for calibration.

If the balance is being operated at the time set for automatic calibration/adjustment, the calibration/adjustment sequence is prompted afterward. Automatic calibration/adjustment is prompted at set times when:

- The set time is reached
- The balance is not in Setup mode
- No alphanumeric input is active (e.g., equation for calculation)
- The load has not been changed within the last 2 minutes
- The balance has not been operated within the last 2 minutes
- The load on the balance does not exceed 2% of the maximum capacity

In the Setup menu, you can configure the balance so that after calibration and adjustment

- the application program is restarted **On and reset the application**
- the application program remains at its previous status **On without resetting the app.**

Also in Setup, you can configure the balance so that it displays a calibration prompt, but does not perform the calibration/adjustment functions automatically

Only adjustment prompt

Switching Off the isoCAL Function in Precision Balances with a Readability ≥ 1 mg Used as Legal Measuring Instruments in the EU*:

Automatic calibration and adjustment is also performed even when **Off** or **Only adjustment prompt** is set in the Setup menu.

Limited temperature range:

- Balances of accuracy class **I**: +15°C to +25°C (59°F to 77°F)
- Balances of accuracy class **II**: +10°C to +30°C (50°C to 86°C)

Standard temperature range:

- 0°C to +40°C (32°F to 104°F)

You can switch off the automatic adjustment function on verified balances with a readability ≥ 1 mg:

- after modification by the Sartorius Customer Service
- > Subsequently the balance can only be used when the ambient temperature range is within legally defined limits.
- The isoCAL function cannot be switched off on balances with a readability ≤ 0.1 mg

* including the Signatories of the Agreement on the European Economic Area

Model	Fully automatic adjustment is initiated under the following conditions: when the temperature changes by	after a time interval of
LA310S, LA230S, LA230P, LA120S, LA3200D, LA1200S, LA2000P	1.5°C	4 h
LA620S, LA620P, LA6200S, LA4200S, LA5200P, LA8200S, LA8200P	2°C	6 h
LA220S, LA2200S, LA2200P, LA34001P, LA34001S, LA64001S	4°C	12 h
LA820, LA420, LA16001S, LA12000S, LA12000P, LA6200, LA4200, LA2200, LA34000	4°C	24 h

These values are also factory set in the verified or verifiable models (with the model number suffix -OCE).

* = not applicable to verified balances

Block Printout

You can have the results of a calibration/adjustment procedure printed out. You can configure whether the printout is generated as soon as the procedure is completed, or whether a number of calibration/adjustment procedures (up to 50) are collected for a block printout.

Loading Stored Data:

Data for the block printout are stored in battery-backed memory. These data remain in memory for approx. 3 months after the equipment is disconnected from AC power. Make sure to generate a printout before disconnecting the equipment for a long period of time.

Block Printout of Calibration/Adjustment Data

With the following Setup menu configuration, you can store the data from up to 50 calibration/adjustment procedures and have them printed on request:

- isoCAL printout
On request, from record memory

When the memory contains 50 data records:

- additional records are output automatically
If at least one block printout data record has been configured, the following soft keys are available after you press the Cal soft key:
Info The number of records is displayed in the text line
PrtPro Print accumulated records
DelPro Delete accumulated records; records can only be deleted after a printout has been generated.
If a password has been assigned in the Setup: Input menu, you must enter either the configured password or the General Password before you can delete the records.

For internal calibration/adjustment, the initialization mode of the procedure is displayed in the Start line.

```
-----  
13.05.1997      09:17  
      SARTORIUS  
Mod.           LA4200S  
Ser. no.       70419914  
Ver. no.       01-35-18  
ID  
-----
```

GLP header

```
24.04.1997      12:03  
Start:         manual  
Diff. +        0.01 g  
External calibration  
      completed
```

List of Calibration/Adjustment Procedures:

Example 1:
External calibration

```
25.04.1997      12:10  
Start:         isoCAL/temp  
Diff. +        0.01 g  
Internal adjustment  
      completed  
Diff. +        0.00 g
```

Example 2:
isoCAL triggered by difference
in temperature

```
25.04.1997      18:30  
Start:         Adj.time  
Diff. +        0.01 g  
Internal adjustment  
      completed  
Diff. +        0.00 g
```

Example 3:
isoCAL at defined time

```
26.04.1997      9:37  
Start:         manual  
Diff. +        0.01 g  
Internal adjustment  
      completed  
Diff. +        0.00 g
```

Example 4:
Internal calibration/adjustment
triggered manually

```
27.04.1997      11:53  
Start:         Ext.cal.  
W ID  
Nom. + 2,000.00 g  
Diff. +        0.01 g  
External calibration  
      completed  
Diff. +        0.00 g
```

Example 5:
External calibration/adjustment

```
-----  
13.05.1997      09:17  
Name:  
-----
```

GLP footer

Application Programs

Soft Key Functions

Start Start application program

Weigh Toggle to basic weighing functions

Using Verified Balances as Legal Measuring Instruments in the EU*: All application programs can be selected on balances verified for use in legal metrology. Calculated values can be indicated as follows:

- Percent = %
- Piece counting (Counting) = pcs
- Computed value = 0, Δ

Auto-Start Application When the Power Goes On

In the Setup menu, you can select whether the last application active before you turn off the power starts automatically when the power is turned on again (Setup: Application parameters: Auto-start app. when power goes on: On)

Toggle between Two Weight Units $\cup \cup$

Purpose

With this application program you can switch the display of a weight value back and forth between two weight units by pressing a soft key.

You can use the "Toggle between Two Weight Units" application in combination with a program chosen from Application 2 (checkweighing, time-controlled functions) and one from Application 3 (totalizing, formulation, statistics) as well as with the extra functions.

Available Features

- Toggling the displayed weight
- Setting the display accuracy
- Other features as for the basic weighing function

Factory Settings

Weight unit 1: **Grams** $\cup \cup$

Display accuracy 1: **All digits**

Weight unit 2: **Grams** $\cup \cup$

Display accuracy 2: **All digits**

* including the Signatories of the Agreement on the European Economic Area

Preparation

Balances used as legal measuring instruments: grams and kilograms are the only weight units available

Standard balances: The following weight units are available in both ranges:

Unit	Conversion factor	Display/Printout	Line for metrological data
Grams	1.00000000000	g	g
Kilograms	0.00100000000	kg	kg
Carats	5.00000000000	ct	ct
Pounds	0.00220462260	lb	lb
Ounces	0.03527396200	oz	oz
Troy ounces	0.03215074700	ozt	ozt
Hong Kong tael	0.02671725000	tlh	tlh
Singapore tael	0.02645544638	tls	tls
Taiwanese tael	0.02666666000	tlt	tlt
Grains	15.43235835000	GN	GN
Pennyweights	0.64301493100	dwt	dwt
Milligrams	1000.00000000000	mg	mg
Parts per pound	1.12876677120	/lb	lb
Chinese tael	0.02645547175	tlc	tlc
Mommes	0.26670000000	mom	M
Austrian carats	5.00000000000	K	K
Tola	0.08573333810	tol	tol
Baht	0.06578947437	bat	bat
Mesghal	0.21700000000	MS	MS

- Turn on the balance: Press $\cup \cup$
- Select the Toggle Weight Units application in the Setup menu: press $\cup \cup$
- Select **Application parameters**: press the \cup soft key 2 x, then the \cup soft key once
- **Application 1 (basic settings)**: press the \cup soft key
- Select **Toggle wt. units**: (repeatedly) press the \cup or \cup soft key
- Confirm **Toggle wt. units**: press the \cup soft key

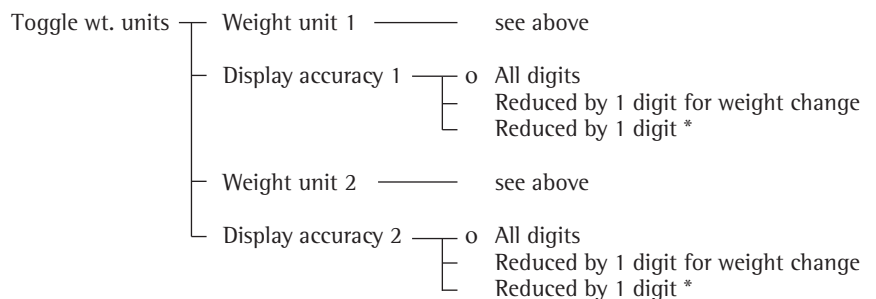

o = factory setting

* = not for verified balances used as legal measuring instruments

see also "Application Parameters (Overview)" in the chapter entitled "Configuration"

- Save settings and exit the Setup menu: press the $\cup \cup$ soft key

Additional Functions

In addition to the functions for:

- alphanumeric input,
- taring (not during alphanumeric input),
- printing (NUM print; S ID), you can also access the following functions from this application:

Calibration/Adjustment
 ● Press the **Cal** soft key

- > See “Calibration/Adjustment” for further instructions

Toggling to the Next Application
 ● Press **↵**

- > See the section on the corresponding application program for further instructions

Setup (setting parameters)
 ● Press **Setup**

- > See “Configuration” for further instructions

Turning Off the Balance
 ● Press **⏻**

- > The balance shuts off

Practical Example

Toggle the Display From Grams [g] (1st Unit) to Troy Ounces [ozt] (2nd Unit)
 Settings (changes in the factory settings required for this example):
 Setup: App: Application 1: Toggle wt. units: Weight unit 2: Troy ounces /ozt

Step	Key (or instruction)	Display/Output
1. Toggle back to weight unit 1, if necessary (U1 : Weight unit 1)	CF	
2. Change weight unit to Troy ounces [ozt] (U2 : Weight unit 2)	ozt soft key	
3. Change weight unit to Grams [g]	g soft key	

Counting

Purpose

With the Counting program you can determine the number of pieces of approximately equal weight.

You can use this application program in combination with a program chosen from Application 2 (checkweighing, time-controlled functions) and one from Application 3 (totalizing, formulation, statistics) as well as with the extra functions.

Features

- Optional balance configuration in Setup for automatically initializing this application and loading the most recent reference sample quantity "nRef" and average piece weight "wRef" when you switch on the balance (this is the automatic setting when the balance is initialized; Setup menu: Application parameters: Auto-start app. when power goes on: On)
- Reference sample quantity "nRef" entered manually
- Average piece weight "wRef" entered manually
- Storage of the current weight value for the preset reference sample quantity "nRef", to be loaded when the Counting program is initialized
- Setting the accuracy when the reference sample weight "wRef" is stored for calculating a piece count
- Automatic output of the quantity and sample weight via the data interface port after initialization or reference sample updating while running the Counting program (Select Setup: App: Basic settings: Printout configuration: Auto print upon initialization: All values)
- Toggling between piece count and weight value by pressing the **Count.** or **Weigh.** soft key
- Toggling between counting and additional applications using the  key (for example, checkweighing)

Factory Settings

Accuracy when calculating piece weight:
Display accuracy

Reference sample updating:
Automatic

Soft Key Functions

- | | |
|---------------|--|
| nRef | Store value input as reference sample quantity |
| wRef | Store input value as reference sample weight |
| Out. | Reference updating criteria met; reference updating can be performed |
| Count. | Toggle to the Counting application |
| Weigh. | Toggle to the weighing mode |
| Start | Store current weight value for the preselected piece count |

Preparation

To calculate a piece count, the average weight of one piece must be known. This average piece weight can be entered into the Counting program in one of three ways:

- Enter the average piece weight using the numeric keys and store it;
- The last reference sample quantity entered is loaded and displayed when you turn on the balance. Place the same number of parts on the balance and initialize the Counting program;
- When the automatic initialization parameter (see previous page), is on (Setup: > Printout: Application-defined output: Autoprint upon initialization: All values; see page 34), the balance goes into the "counting" mode when you turn it on and loads the last average piece weight and corresponding reference sample quantity that were entered or calculated.

Reference Sample Updating

You can have the average piece weight updated during counting (with the piece count displayed) if "AWP update" is set to "manual" or "automatic" in the Setup menu. Manual updating can only be performed when the **Update** soft key is displayed. Reference sample updating must be completed before using an application program from Application 3.

The **Out.** soft key is displayed when:

- the balance has stabilized (stability symbol displayed)
- the current piece count is not more or less than double the original piece count
- the current piece count is less than 100
- the internally calculated piece count (e.g., 17.24) differs from the nearest whole number (in this case: 17) by less than ±0.3

Reference updating can be repeated several times with an approximately doubled piece count.

- To perform reference updating: press the **Out.** soft key
- Turn on the balance: press **1/0**
- > Sartorius logo is displayed
- Select the Counting application in the Setup menu: press **Setup**
- Select the **Application parameters**: press the **v** key 2x, then the **>** soft key once
- Select **Application 1 (basic settings)**: press the **>** soft key
- Select **Counting**: repeatedly press the **^** or **v** soft key
- Confirm **Counting**: press the **>** soft key

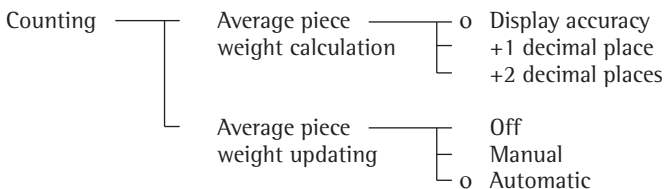

o = factory setting

see also the "Application Parameters (Overview)" in the chapter entitled "Configuring the Balance"

- Save settings and exit the Setup menu: press the **<<** soft key

Additional Functions

In addition to the functions for:

- alphanumeric input,
- taring (not during alphanumeric input),
- printing,

you can also access the following functions from this application:

Calibration/Adjustment

- Press the **Cal** soft key
- > See "Calibration/Adjustment" for further instructions

Toggleing to the Next Application

- Press **↔**
- > See the section on the corresponding application program for further instructions

Setup (Setting Parameters)

- Press **Setup**
- > See "Configuration" for further instructions

Turning Off the Balance

- Press **1/0**
- > The balance shuts off

Weighing in Percent ☒

Purpose

This application program allows you to obtain weight readouts in percent which are in proportion to a reference weight.

Alternatively, you can have the value displayed as a difference in percent between the weight on the balance and the reference weight, or as a special ratio1 or ratio2.

You can use the “Weighing in Percent” application in combination with a program chosen from Application 2 (checkweighing, time-controlled functions) and one from Application 3 (totalizing, formulation, statistics) as well as with the extra functions.

Available Features

- Reference percentage “pRef” loaded from long-term memory when you turn on the balance
- Optional balance configuration in Setup for automatically initializing this application and loading the most recent reference percentage “pRef” entered with reference weight “Wxx%” when you turn on the balance (Setup: App: Auto start application when power goes on: On).
- Value displayed as:
 - Residual quantity (portion)
 - Difference (deviation)
 - Ratio1
 - Ratio2depending on the selected Setup menu code.
- Reference percentage “pRef” entered manually
- Store the current weight as the reference percentage weight “Wxx%” for initializing the weighing-in-percent application program
- Reference weight “Wxx%” entered manually
- Storage parameter (rounding-off factor) for storing the reference weight “W100%” in percentage calculation can be configured
- Configuration of decimal places displayed with a percentage
- Optional configuration for having the reference weight “Wxx%” and reference percentage automatically output via the data interface port after initialization (print application parameters) (Select Setup: Printout: Application-defined output: Auto print upon initialization: All values)
- Toggle the display between percentage and weight readout by pressing the **Wei sh.** or **Per c.** soft key
- Toggle between the weighing-in-percent program and other applications (e.g., checkweighing) by pressing 

Factory Settings

Storage parameter:

Display accuracy

Digits displayed with percentage:

2 digits

Display calculated value: **Residue**

Soft Key Functions

- pRef** Store value input as reference percentage
- Wxx%** Store input value as reference sample weight
- Per c.** Toggle to the Weighing-in-percent application
- Restar** Start next weighing operation
- Wei sh.** Toggle to the weighing mode
- Start** Store current weight value for preselected percentage

Preparation

To calculate a value in percent, the reference percentage must be known. This value can be entered into the weighing-in-percent program in one of three ways:

- The last reference percentage entered is loaded and displayed when you turn on the balance. Place the corresponding weight on the balance and initialize the weighing-in-percent program;
- With automatic initialization switched on (Setup: App: Auto start application when power goes on: On), the balance goes into the “weighing in percent” mode when you turn it on and loads the last reference percentage entered as well as the corresponding reference weight;
- Enter the reference weight using the numeric keys and store it (M x x % soft key).

● Turn on the balance: Press 

> Sartorius logo is displayed

● Select the Weighing in percent application in the Setup menu: Press 

● Select **Application parameters**: press the ∇ soft key 2x, then the \triangleright soft key once

● Select **Application 1 (basic settings)**: press the \triangleright soft key

● Select **Percent weigh.**: repeatedly press the \wedge or ∇ soft key

● Confirm **Percent weigh.**: press the \triangleright soft key

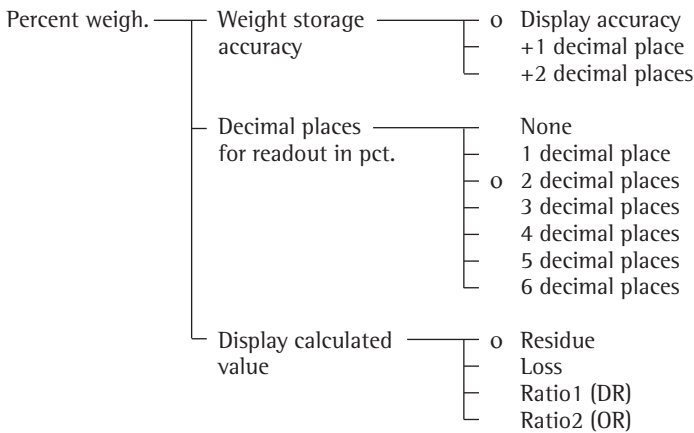

o = factory setting

see also the “Application Parameters (Overview)” in the chapter entitled “Configuration”

● Save settings and exit the Setup menu: press the \llcorner soft key

Equations

The following equations are used for the corresponding calculations:

Residue (weighing in percent) = $\text{Current weight} / 100\% \text{ weight} \times 100\%$
 Loss (percent-DIFF:) = $(\text{Current weight} - 100\% \text{ weight}) / 100\% \text{ weight} \times 100\%$
 Ratio1 (percent-Ratio 1:) = $(100\% \text{ weight} - \text{current weight}) / \text{current weight} \times 100\%$
 Ratio2 (percent Ratio 2:) = $100\% \text{ weight} / \text{current weight} \times 100\%$

Additional Functions

In addition to the functions for:

- alphanumeric input,
- taring (not during alphanumeric input),
- printing,

you can also access the following functions from this application:

Calibration/Adjustment

- Press the **C a l** soft key
- > See “Calibration/Adjustment” for further instructions

Toggleing to the Next Application

- Press 
- > See the section on the corresponding application program for further instructions

Setup (setting parameters)

- Press 
- > See “Configuration” for further instructions

Turning Off the Balance

- Press 
- > The balance shuts off

Examples

Weighing in Percent with Reference Weight Taken From Weight on Balance

Settings (changes in the factory settings required for this example):

Setup: App: Application 1: Weighing in percent

Setup: App: Printout: Application-defined output: Auto print upon initialization: All values

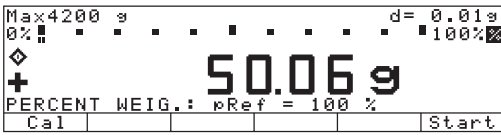
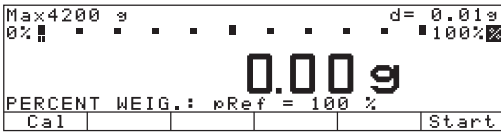
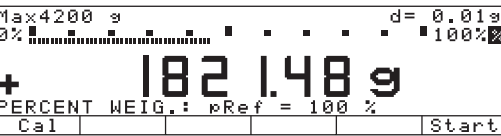
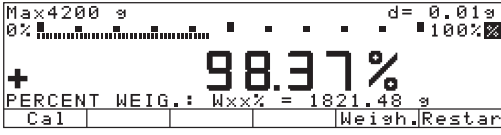
Step	Key (or instruction)	Display/Output
1. Delete previous setting if necessary	CF	 <p>Max4200 g d= 0.01g 0% 100% 50.06 g PERCENT WEIG.: pRef = 100 % Cal Start</p>
2. Prepare a container for the parts	Place the empty container on the balance	
3. Tare the balance	Tare	 <p>Max4200 g d= 0.01g 0% 100% 0.00 g PERCENT WEIG.: pRef = 100 % Cal Start</p>
4. Place the reference weight on the balance (here: 1821.48 g = 100%)	Place weight equal to reference weight in the container	
5. Initialize the balance	Start soft key	 <p>Max4200 g d= 0.01g 0% 100% 100.00 % PERCENT WEIG.: pRef = 100 % Wxx% = 1821.48 g Cal Weigh.Restar</p> <p>pRef + 100 % Wxx% + 1821.48 g</p>
6. Unload the balance	Remove reference sample from the container	
7. Determine the percentage of an unknown weight	Place sample to be measured in the container	
8. If desired, print percentage (here: 98.37%)	Print	 <p>Max4200 g d= 0.01g 0% 100% 98.37 % PERCENT WEIG.: Wxx% = 1821.48 g Cal Weigh.Restar</p> <p>Prc + 98.37 %</p>

Animal Weighing

Purpose

Use this program to determine the weights of unstable samples (e.g., live animals) or to determine weights under unstable ambient conditions. In this program, the balance calculates the weight as the average of a defined number of individual weighing operations. These weighing operations are also known as “subweighing operations.”

You can use the “Animal Weighing” application in combination with a program chosen from Application 2 (checkweighing, time-controlled functions) and one from Application 3 (totalizing, formulation, statistics) as well as with the extra functions.

Available Features

- Animal weighing started manually or automatically
- Automatic start:
 - when a defined threshold has been exceeded (Minimum load threshold: 10; 20; ...; 500; 1,000 display increments)
 - when three successive subweights lie within a user-defined tolerance range (calm; normal; active; 0.1%; 0.2%; ...; 50%; 100% of the animal/object)
- Manual start:
 - also possible when the load is under the minimum load threshold
 - when three successive subweights lie within a user-defined tolerance range (calm; normal; active; 0.1%; 0.2%; ...; 50%; 100% of the animal/object)

- Optional balance configuration in the Setup menu for automatically initializing this application when you turn on the balance
- Number of weighing operations for calculation of an average (**mDef**) can be entered before the beginning of each animal weighing operation
- The factor for calculation of the result can be entered before the beginning of each animal weighing operation
- The number of subweighs remaining to be performed is indicated in the text display during weighing
- Arithmetic average displayed as a result in the pre-set weight unit (identified by the  symbol).
- Optional multiplication of the arithmetic average by a user-defined factor **Mu1**.

A circle “o” is displayed as weight unit and **Mu1 = xxx** is shown in the text line
- Toggling between the animal weight and the calculated value by pressing the **xNet** soft key and the **xRes** soft key
- Automatic output of results via the interface port:
 - Number of weighing operations **mDef**
 - Multiplication factor **Mu1**
- Automatic output of results (printout) via the interface port:
 - Weighing result **xNet**
 - Calculated result **xRes**
 The following options have to be selected: Setup: Printout: Application-defined output: Auto print upon initialization: All values
- The unload threshold is equal to one-half the minimum balance capacity
- Return to weighing mode by unloading the balance; i.e., when the load is below the unload threshold

Factory Settings

Animal activity:
5% of the animal/object

Start: **Automatic**

Minimum load for automatic storage:
100 display increments

Decimal places in result display:
2 decimal places

Printout:
Average weight only

Soft Key Functions

New Automatic start:

- Unload balance and weigh next animal, if desired
- Press key to start next subweigh

Manual start:
Start next subweigh

mDef Store user-defined number of subweighs for averaging

Mu1 Store user-defined factor as multiplication factor for calculating the arithmetic mean

xNet Toggle to the animal weight

xRes Toggle to the calculated animal weighing result

Printout for Animal Weighing

Upon completion of the averaging process, you can have the results printed out automatically. You can also have both the weight and the calculated result printed.

```

mDef          10
Mul           0.347
xNet  +  153.00 g
xRes  +   53.91 o
  
```

mDef: Numbers of subweighing operations for averaging

Mul: Multiplication factor

xNet: Result of averaging

xRes: Calculated result

Preparation

- Turn on the balance: Press I/O
- > Sartorius logo is displayed
- Select the Animal weighing application in the Setup menu: Press Setup
- Select **Application parameters**: press the V soft key 2 x, then the > soft key once
- Select **Application 1 (basic settings)**: press the > soft key
- Select **Animal weigh.**: ^ or V soft key repeatedly
- Confirm **Animal weigh.**: > soft key

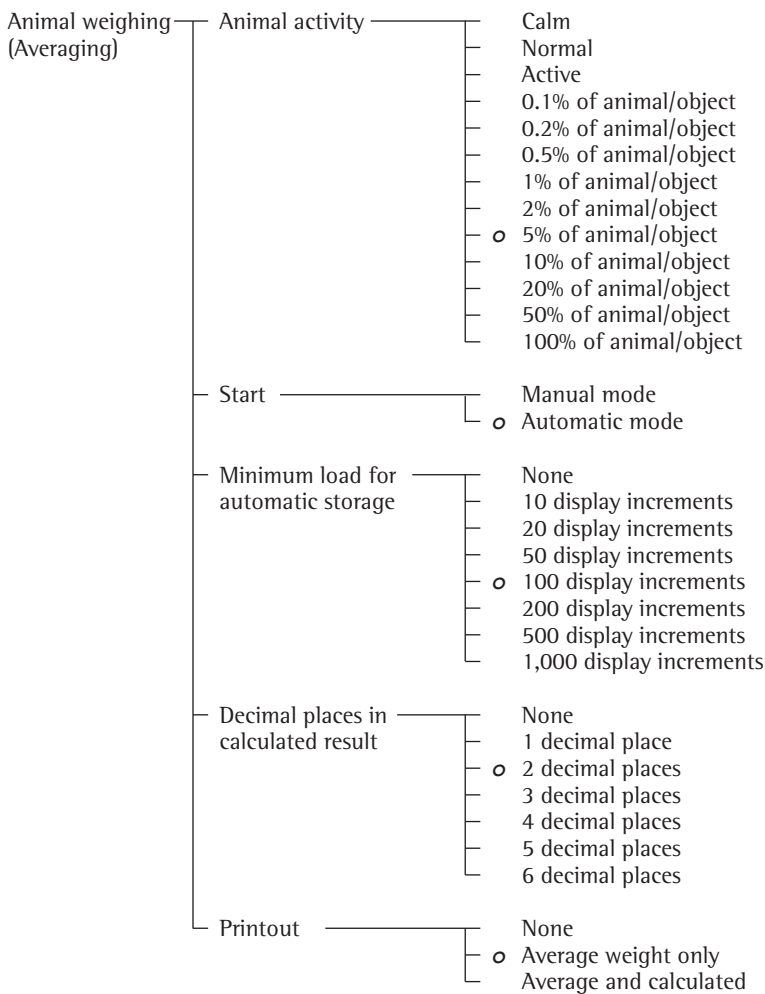

○ = factory setting

see also the “Application Menu (Overview)” in the chapter entitled “Configuration”

- Save settings and exit the Setup menu: Press the << soft key

Additional Functions

In addition to the functions for:

- alphanumeric input,
- taring (not during alphanumeric input),
- printing,

you can also access the following functions from this application:

Calibration/Adjustment

- Press the Cal soft key
- > See “Calibration/Adjustment” for further instructions

Toggle to the Next Application

- Press ^
- > See the section on the corresponding application program for further instructions

Setup (setting parameters)

- Press Setup
- > See “Configuration” for further instructions

Turning Off the Balance

- Press I/O
- > The balance shuts off
- > The display goes blank, then OFF/Standby is displayed with backlighting

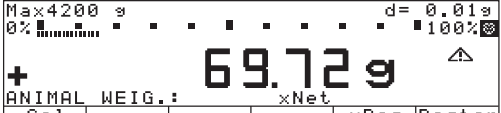
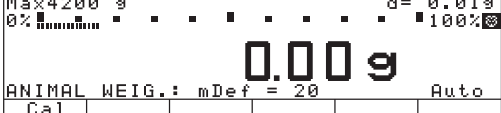
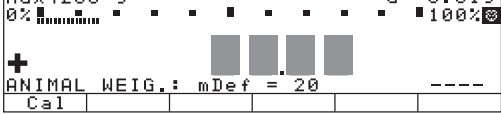
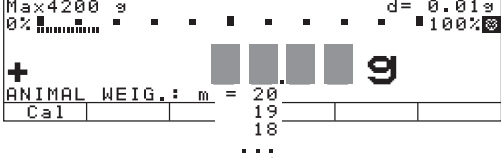
Step	Key (or instruction)	Display/Output												
After 20 subweighing operations the arithmetic average (xNet) is display		 <p>Max4200 g d= 0.01g 0% 100% + 69.72g ANIMAL WEIG.: xNet Cal xRes Restar</p>												
(mDef: no. of subweighs Mu1: calculation factor xNet: arithm. average, net value xRes: calculated value)		<table border="1" data-bbox="941 548 1444 672"> <tr> <td>mDef</td> <td></td> <td>20</td> </tr> <tr> <td>Mu1</td> <td></td> <td>1</td> </tr> <tr> <td>xNet</td> <td>+</td> <td>69.72 g</td> </tr> <tr> <td>xRes</td> <td>+</td> <td>69.72 o</td> </tr> </table>	mDef		20	Mu1		1	xNet	+	69.72 g	xRes	+	69.72 o
mDef		20												
Mu1		1												
xNet	+	69.72 g												
xRes	+	69.72 o												
8. Unload the balance	Remove animal from cage	 <p>Max4200 g d= 0.01g 0% 100% 0.00g ANIMAL WEIG.: mDef = 20 Auto Cal</p>												
9. If desired, weigh next animal	Place animal in cage	 <p>Max4200 g d= 0.01g 0% 100% + [bars] ANIMAL WEIG.: mDef = 20 ---- Cal</p>												
Next weighing series begins automatically		 <p>Max4200 g d= 0.01g 0% 100% + [bars] g ANIMAL WEIG.: m = 20 Cal 19 18 ... 1</p>												

Calculation $\frac{\square}{\square}$

Purpose

With this application program you can calculate a weight value using an algebraic equation. This can be used, for example, to determine the gsm weight (grams per square meter) of paper.

You can use the “Calculation” application in combination with a program chosen from Application 2 (checkweighing, time-controlled functions) and one from Application 3 (totalizing, formulation, statistics) as well as the extra functions.

Available Features

- You can store an equation and configure the Setup menu to initialize this program automatically with the stored equation (Setup: App: Basic settings : Auto start upon initialization: On)
- The \circ symbol is displayed to indicate a calculated value. The equation used is displayed in the text line
- If no equation was entered, the weight value is displayed
- Toggle between the weight readout, equation input and display of the calculated result by pressing the corresponding soft keys (or press $\text{\textcircled{CF}}$ to toggle between weight and calculated value)
- There are four operators (+, -, *, /) and one factor (weight value) available when you enter an equation
- Max. equation length: 28 characters
- Pressing $\text{\textcircled{CF}}$ will delete either the equation or the last character entered, depending on the configuration in the Setup menu (Setup: Device: Keys: CF function for input: Delete last character)
- The calculated result is displayed with the number of decimal places configured in the Setup menu. Not all decimal places are displayed if the result is longer than the display allows. If there are more digits before the decimal point than the display can show, an error message is displayed.
- The equation is stored in non-volatile memory

Factory Settings

Decimal places in calculated result:
2 decimal places

Soft Key Functions

- Equat.** Toggle to equation
- +** Enter an addition operator in the equation
- Enter a subtraction operator in the equation
- *** Enter a multiplication operator in the equation
- /** Enter a division operator in the equation
- Weight** Enter a weight value in the equation
- Start** Start calculation
- Weigh.** Toggle to the weighing mode

Preparation

- Turn on the balance: Press $\text{\textcircled{U\phi}}$
- > Sartorius logo is displayed
- Select the Calculation application program in the Setup menu: Press $\text{\textcircled{Setup}}$
- Select the **Application parameters**: press the \downarrow soft key 2 x, then the \rightarrow soft key once
- Select **Application 1 (basic settings)**: press the \rightarrow soft key
- Select **Calculation**: press the \uparrow or \downarrow soft key, repeatedly, if necessary
- Confirm **Calculation**: press the \rightarrow soft key

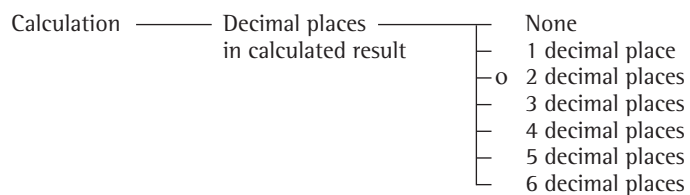

\circ = factory setting

see also the “Application Parameters (Overview)” in the chapter entitled “Configuration”

- Save settings and exit the Setup menu: press the $\leftarrow \leftarrow$ soft key

Practical Example

Calculate the gsm weight of paper: determine the gsm of a sheet of A4 paper with the dimensions $0.210\text{ m} \times 0.297\text{ m} = 0.06237\text{ m}^2$. The gsm weight is a product of the division of the weight by the surface area.

Settings (changes in the factory settings required for this example):

Setup: App: Application 1: Calculation

Step	Key (or instruction)	Display/Output
1. Turn on the balance and configure the settings as indicated above		
2. Delete previous setting if necessary		
3. Tare the balance		
4. Select equation input	EQUAT. soft key	
5. Enter weight value Enter division sign Enter the surface area of a sheet of A4 paper	Weight soft key / soft key 	
6. Turn on the calculated result display	Start soft key	
7. Determine the gsm weight	Place A4 sheet	

Density Determination

Purpose

With this application you can determine the density and volume of solid, pasty, liquid or powdered samples.

You can use the "Density Determination" application in combination with a program chosen from Application 2 (e.g., checkweighing, timer functions) and one from Application 3 (totalizing, formulation, statistics) as well as the extra functions.

Available Features

- Choose from 2 methods for determining density of solids:
- Buoyancy, or

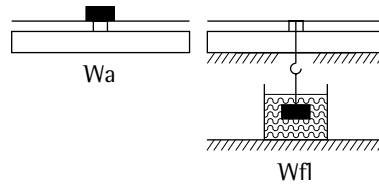

- displacement.

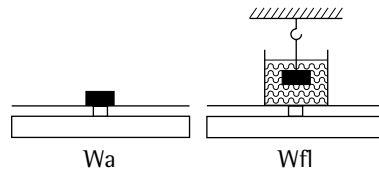

- Density determination on pasty or powdered samples using the pycnometer method

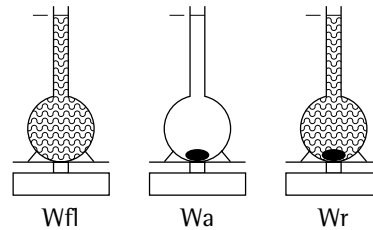

- Density determination on liquids using the liquid density method
- Choice of liquids for buoyancy:
 - Water
 - Ethanol
 - Other liquids (user-definable)
- Reference values can be entered using the numeric keys
 - Weight of sample in air (W_a)
 - Weight of sample in liquid, or weight of reference liquid when using the pycnometer (W_{fl})
 - Weight of sample and reference liquid when using the pycnometer (W_r)
- Long-term storage of parameters:
 - Temperature
 - Buoyancy correction
 - Air density
 - Density of reference liquid
 - Expansion coefficient
 - Plummets volume

Factory Settings

Method: **Buoyancy**

Liquid causing buoyancy: **Water**

No. of decimals for display of vol. density: **2 decimals**

Printout: **None**

Soft Key Assignments

- W_a** Store weight of sample in air
- W_{fl}** With liquid density, buoyancy and displacement methods:
 - Store weight of sample in liquid
 - With pycnometer method:
 - Store weight of reference liquid
- W_r** With pycnometer method: Store weight of sample and liquid
- Start** Start a new measurement routine
- Param.** Toggle to parameter input mode (depending on method selected)
- Densit** Display the density (the parameters set remain effective for the next measurement)
- Weigh** Display the weight (the parameters set remain effective for the next measurement)
- Vol.** Display the volume (the parameters set remain effective for the next measurement)

Equations Used to Determine Density:
Buoyancy: $\text{Rho} = (\text{Wa} \times (\text{Rho}_{\text{fl}} - \text{LA})) \div ((\text{Wa} - \text{Wfl}) \times \text{Corr}) + \text{LA}$

For the buoyancy method, a factor of 0.99983 (factory setting) is used to allow for the buoyancy caused by the bars of the sample holder of the YDK 01 (LP) Density Determination Kit. This factor is yielded by allowing for this equation:
buoyancy of bars = $2 \times d^2 \div D^2 (\text{Wa} - \text{Wfl})$

The equation takes the following variables into consideration: the number of wires or bars, the wire/bar diameter of the sample holder, and the inner diameter of the vessel used.

The factor 0.99983 is yielded by $1 - 2 \times d^2 \div D^2$

where: 2 = number of wires/bars
d = wire/bar diameter (0.7 mm*)
D = inner diameter of the vessel (76 mm*)

If you are using different vessels or other density kits, press the **Par.am.** soft key to enter any necessary changes in this calculation factor.

To determine the density of a solid according to the buoyancy method with our YDK 01 (LP) Density Determination Kit, make sure to use the beaker with a 76 mm diameter.

Displacement: $\text{Rho} = (\text{Wa} \times (\text{Rho}_{\text{fl}} - \text{LA})) \div (\text{Wfl} \times \text{Corr}) + \text{LA}$

For the displacement method, a factor of 1.00000 (factory setting) is used to allow for the buoyancy caused by a wire suspended in the liquid.

If you are using different vessels or other density kits, press the **Par.am.** soft key to enter any necessary changes in this calculation factor.

The equation takes the following variables into consideration: the number of wires or bars, the wire/bar diameter of the sample holder, and the inner diameter of the vessel used.

This factor is yielded by: $\text{Corr} = 1 - \chi \times d^2 \div D^2$



where: χ = number of wires
d = wire diameter
D = inner diameter of the vessel

with:
Rho_{fl} = density of the reference liquid
Wa = weight of sample in air
Wfl = weight of the sample in liquid/buoyancy of sample
Corr = correction for buoyancy produced by the immersed wires or bars of the sample holder:
0.99983 for the buoyancy method
1 for the displacement method
LA = correction for air buoyancy = 0.0012 g/ccm

Pycnometer:
where:
Rho = $(\text{Wa} \times (\text{Rho}_{\text{fl}} - \text{LA})) \div (\text{Wfl} + \text{Wa} - \text{Wr}) + \text{LA}$
Rho_{fl} = density of the reference liquid
Wa = weight of the sample
Wfl = weight of the reference liquid
Wr = weight of sample + the reference liquid
LA = correction for air buoyancy = 0.0012 g/ccm

* For the YDK 01 (LP) Density Determination Kit

Preparation

- Turn on the balance: Press 
- > Sartorius logo is displayed
- Select the Density application in the Setup menu: Press 
- Select the **Application parameters**: press the ∇ soft key 2x, then the \triangleright soft key once
- Select **Application 1 (basic settings)**: press the \triangleright soft key
- Select **Density**: press the \uparrow or ∇ soft key, repeatedly, if necessary
- Confirm **Density**: press the \triangleright soft key

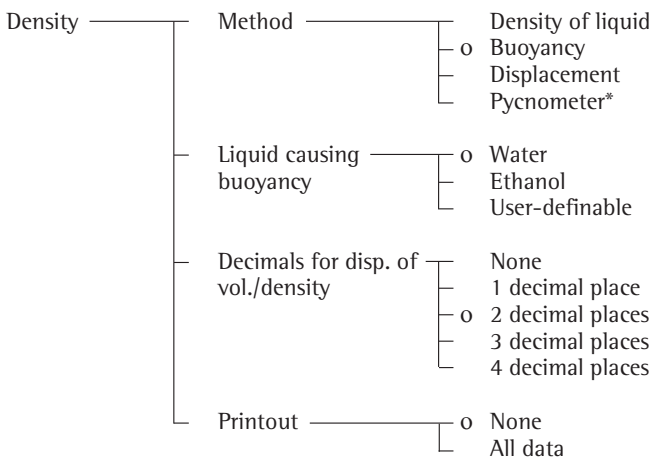

o = factory setting

see also the "Application Parameters (Overview)" in the chapter entitled "Configuration"

- Save settings and exit the Setup menu: press the $\llcorner \llcorner$ soft key

Additional Functions

In addition to the functions for:

- alphanumeric input,
- taring (not during alphanumeric input),
- printing,

you can also access the following functions from this application:

Calibration/Adjustment

- Press the **Cal** soft key
- > See "Calibration/Adjustment" for further instructions

Toggle to the Next Application

- Press 
- > See the section on the corresponding application program for further instructions

Setup (setting parameters)

- Press 
- > See "Configuration" for further instructions

Turning Off the Balance

- Press 
- > The balance shuts off







* = How to run this application is described in detail in our "Genius ME". Installation and Operating Instructions. Request your copy directly from Sartorius or download it from the Internet (www.sartorius.com); see "download"

Practical Example

Buoyancy: Determine the Density of Samples of a Solid Using the Buoyancy Method. Reference Liquid: Water.

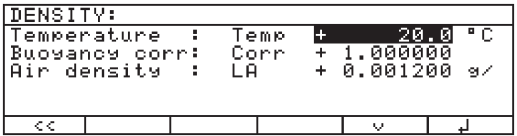
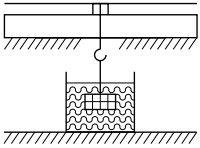
Settings (changes in the factory settings required for this example):

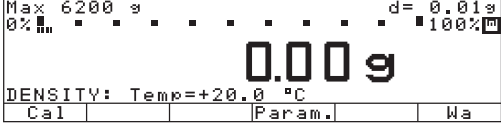
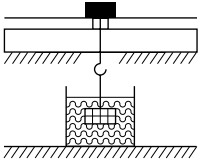
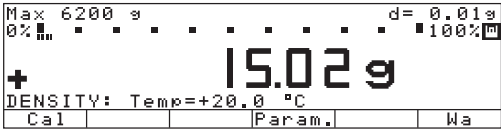
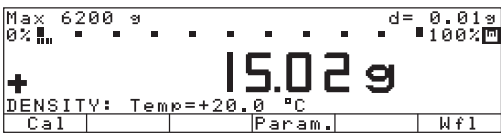
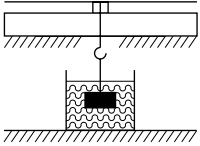
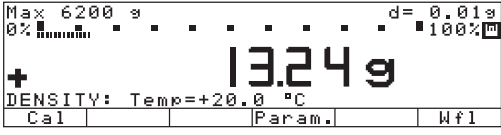
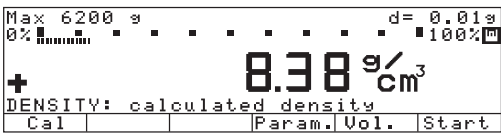
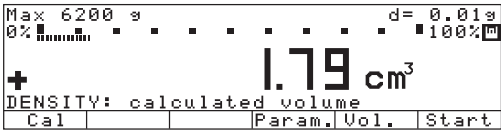
Setup: App: Application 1: Density

Step	Key (or instruction)	Display/Output
1. Delete previously stored values if necessary		
2. Change configurations, if necessary	Param. soft key	
3. Position the sample holder (immersed)		
4. Tare the balance		
5. Determine the weight of the sample in air: place sample on the weighing pan		
6. Store weight value	Wa soft key	
7. Determine the weight of the sample in liquid: place sample in the sample holder		
8. Store weight Density of sample is displayed	Wf1 soft key	
9. Display volume of sample	Vol. soft key	
10. Display weight	Weigh soft key	
11. Repeat procedure with next sample, if desired	Start soft key	

Practical Example



Displacement: Determine the Density of Samples of a Solid Using the Displacement Method.

Reference Liquid: Ethylene glycol. Temperature: 23°C (73.4 °F). Set the density at 20°C (68°F) to 1.113 g/cm² and the volume expansion coefficient at 20°C (68°F) to 0.00064 grd⁻¹.

Settings (changes in the factory settings required for this example):

Setup: App: Application 1: Density: Method: Displacement

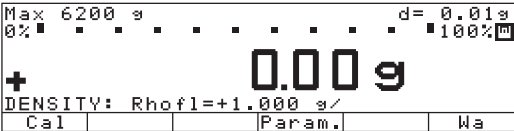
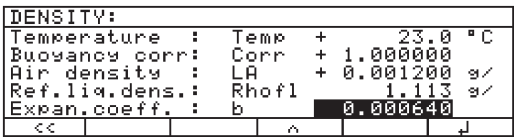
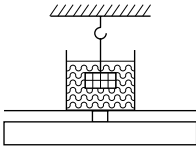
Setup: App: Application 1: Density: Liquid for buoyancy: User-definable

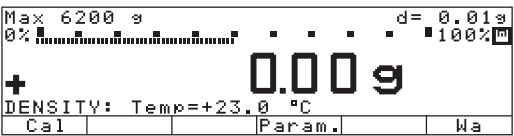
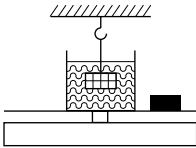
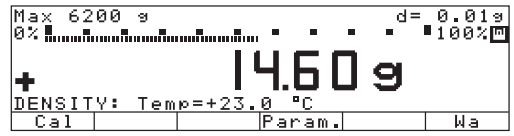
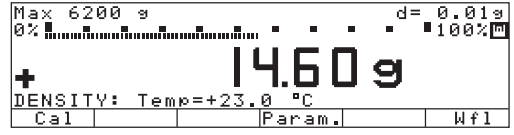
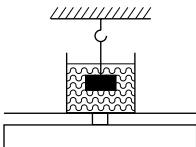
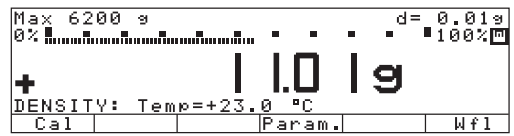
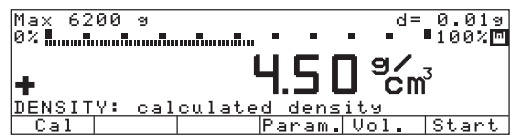
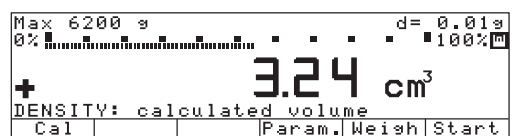
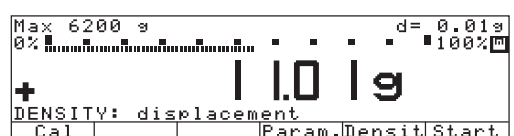
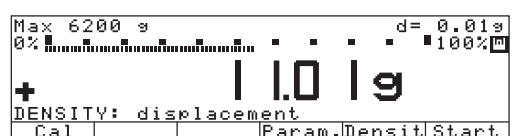
Step	Key (or instruction)	Display/Output
1. Delete previously stored values if necessary		
2. Change configurations: Temperature: 23.0 Density of ref. liquid: 1.113 Expansion coefficient: 0.000640	Param. soft key	
3. Place the container with the reference liquid on the balance		
4. Tare the balance		
5. Determine the weight of the sample in air: place sample on the weighing pan		
6. Store weight value	Wf1 soft key	
7. Determine the weight of the sample in liquid: place sample in the sample holder		
8. Store weight Density of sample is displayed	Wf1 soft key	
9. Display volume of sample	Vol. soft key	
10. Display weight	Weigh soft key	
11. Repeat procedure with next sample, if desired	Start soft key	

Differential Weighing ↗

Purpose

This application enables you to compare samples before and after a given treatment (such as drying or ashing) and determine the difference in weight.

There are different procedures available for this application:

- Collect all data (tare, initial weight, and backweighing result) for each sample individually (menu setting "Weighing sequence: Individual weighing")
- Save the tare weights and initial weights for all samples first, then perform backweighing (menu setting "Combined weighing")
- Save the tare weights for all samples first, then determine the initial weight of each sample and, finally, perform backweighing (serial weighing)

Features

- 4 different sequences for measuring the tare weights, initial sample weights and the backweights (backweighing result):
 - Individual weighing
 - Consecutive individual weighing
 - Combined weighing
 - Serial weighing
- Choice of weighing sequence by selecting this parameter in the Setup menu or by pressing the **Wg. seq** soft key (if the "Weighing sequence key" option is set)
- Perform up to 99 backweighing routines on a single sample
- Differential weighing with or without tare weighing (not necessary for measuring coatings or lamination layers)
- Define the number of decimal places displayed for calculated results
- Define whether autosaving weight values is dependent on the stability parameter
- Define whether the minimum load for autosave is dependent on the display
- List function, with
Display page for lots:
Lists all lots (up to 100 max.) with the number of samples in each lot and the processing status (tare weight, initial weight, backweighed residue ("backweight"))
View, create, rename or delete lots generated
Enter or change a factor for calculation of results
- Display page for samples:
Lists all samples (up to 999 max.) with processing status
View, delete, omit, or include samples
- Display page for measured values:
Shows date, time, ID and values measured
- Display page for results:
Values calculated for a sample (backweight, loss, ratio1, ratio2)

- Special display page for statistics lets you define whether lot statistics are dependent on backweight, loss, or ratio values
- Press a soft key to view the desired display page (lots, samples, values or results)
- To view lot, sample or measured value data, enter the ID and then press the corresponding soft key (**Lot/Sample/Values**)
- Define whether printer output is dependent on the processing status of the sample
- Printout can contain individual values, backweighed values and statistics
- User-definable printout format
- The configurations for the weighing sequence and results are saved separately for each lot

Differential Weighing: Defining the Weighing Sequence

You can choose from among four sequences for measuring tare weights, initial sample weights and backweighed residue ("backweight") during differential weighing:

1. Individual Weighing

Tare weight, initial weight and back-weight are measured in that order.

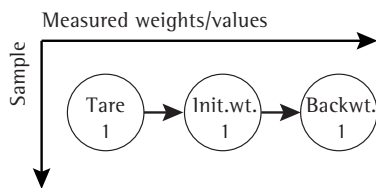

2. Consecutive Individual Weighing

Several individual weighing routines (see above) are performed in series.

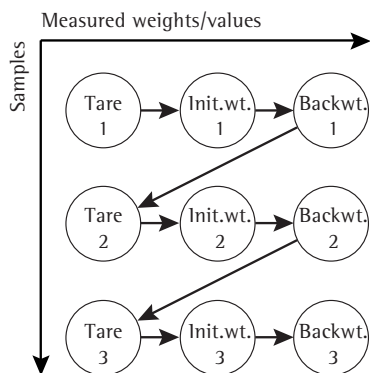

3. Combined Weighing

The tare and initial weight, in that order, of each sample is measured first, then the backweight of each sample is measured.

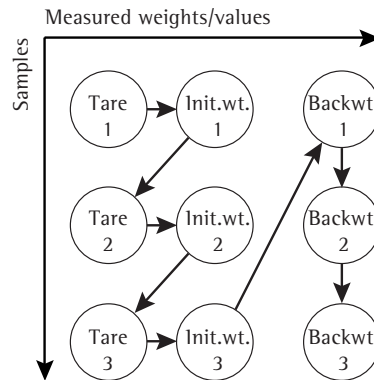

4. Serial Weighing

First the tare weight for each sample is measured, then the initial weight of each sample is measured in the same order that their tare weights were measured, and then all backweights are measured.

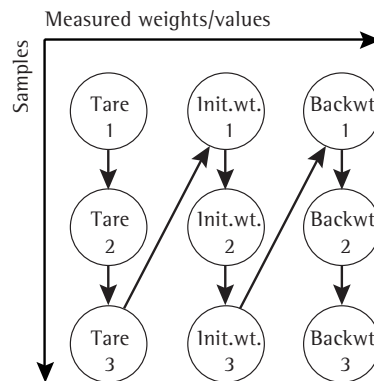

You can define the weighing sequence in the Setup menu or by pressing the **Wg. seq.** (if the "Weighing sequence key" option is activated).

Factory Settings of the Parameters

Weighing sequence: **Group weighing**

Tare weighing: **Yes**

Result with decimal point: **2 decimal places**

Autosave values: **No**

Minimum load for autosave: **20 digits**

Save statistics: **No**

Generate printout: **Automatic after backweighing**

Include sample ID in the text line: **No**

Wg. seq. key: **Yes**

Clear sample after individual weight, result + unload: **No**

Last residual weight saved as the initial weight: **No**



Printout for Differential Weighing

Generating Printouts Automatically

The configured backweighing printout is generated automatically after backweighing, if one of the following settings is selected Setup: Application 1: Differential weighing: Generate print-out:

```
Automatic after
backweighing
Auto after init.weigh
+ backweigh
Auto after tare-,
init- +backweigh.
```

Generating Printouts Manually

The individual printout is generated when the  key is pressed while there is a tare, initial or backweight on the balance, or when  is pressed to toggle applications.

You can generate the configured printout manually after backweighing if you press the  key while the display page for the results is shown.

To generate the statistics printout, press the  key

The following printout is generated:



Backweighing Printout (Example)

```
-----
16.11.1999 14:55:12
Lot CH12345
Sample 14
ID CX88
T1 + 23.458 g
N1 + 125.572 g
R (3)+ 103.684 g
D + 82.57 %
D - 21.887 g
D - 17.43 %
Fact + 1.10345
D-Res - 24.15 o
Ratio1+ 21.11 %
Ratio2+ 121.11 %
-----
```

Dotted line
Date/time
Lot ID
Sample number
Sample ID
Tare weighing (with PT1 selected)
Initial weight
Backweight (residue as weight)
Residue in percent
Loss as a weight
Loss in percent
Calculation factor
Calculated loss
Ratio 1
Ratio 2
Dotted line

- when the display page for statistics is shown,
- when the samples with a desired number of backweighing operations is selected (for example, statistics on all samples with 2 backweighing operations).

Preparation

- Turn on the balance: press 
- > Sartorius logo is displayed
- Select the Differential Weighing application in the Setup menu: press 
- Select the **Application parameters**: press the ∇ soft key 2x, then the \rightarrow soft key once
- Select **Application 1 (basic settings)**: press the \rightarrow soft key
- Select **Differential weighing**: press the Δ or ∇ soft key, repeatedly, if necessary
- Confirm **Differential weighing**: press the \rightarrow soft key

¹⁾ Setting can only be changed when the application is first run and when the **Wg. seq** key option is set to "No"

²⁾ The last value with the stability symbol is saved only during initial sample weighing. Tare and back-weights are saved as the "first value at stability." This menu option enables you to perform filling functions during initial weighing.

³⁾ To autosave a value between 70 and 130% of the initialization value, the balance must be unloaded to below 30% or loaded to above 170% of this initialization value.

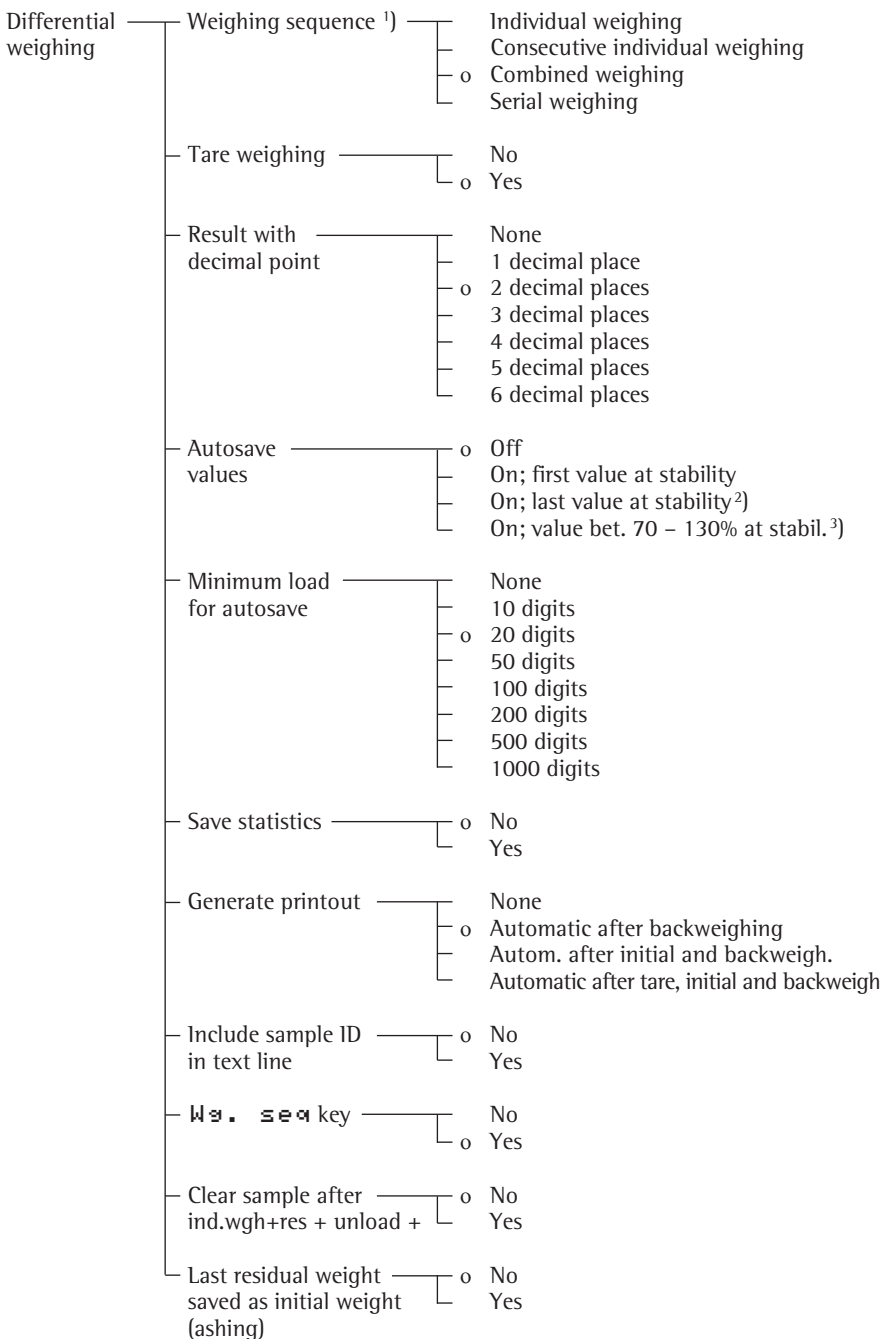

= factory setting

Equations

Backweight in %:	$\text{backweight} / \text{initial weight} \cdot 100\%$
Loss in weight:	$\text{backweight} - \text{initial weight}$
Loss in %:	$(\text{backweight} - \text{initial weight}) / \text{initial weight} \cdot 100\%$
Calculated loss:	$(\text{backweight} - \text{initial weight}) \cdot \text{factor}$
Ratio 1 in %:	$(\text{initial weight} - \text{backweight}) / \text{backweight} \cdot 100\%$
Ratio 2 in %:	$\text{initial weight} / \text{backweight} \cdot 100\%$

Function of the Key

Weighing sequence	Status	Press  key	Value deleted	Subsequent status
Individual weighing	Tare weighing	–	–	–
	Initial weighing	1 ×	Tare	Tare weighing
	Backweighing	1 ×	Initial weight	Initial weighing
	Results displayed	2 ×	Tare	Tare weighing
		1 ×	Backweight	Backweighing
	Results displayed	1 ×	Backweight	Backweighing
Consecutive individual weighing	As for individual weighing			
Combined weighing	Tare weighing	1 ×	Previous init. weight	Initial weighing
		2 ×	Previous tare value	Tare weighing
	Initial weighing	1 ×	Tare	Tare weighing
	Backweighing	1 ×	Previous backweight	Backweighing
	Results displayed	1 ×	Last backweight	Backweighing
Serial weighing	Tare weighing	1 ×	Previous tare value	Previous tare weighing
	Initial weighing	1 ×	Previous init. weight	Previous initial weighing
	Backweighing	1 ×	Previous backweight	Previous backweighing
	Results displayed	1 ×	Last backweight	Backweighing

Soft Key Functions

Create	Create a new lot	Values	Select/view the display page for values
Lot	Select/view the display page for lots	Sample	View the display page for samples
Ini.wt.	Save initial weight	Spl#	Select/create sample data record
>Ini.w	Go to initial weighing function	Backw.	Save backweight value
Result	View display page for results	>Backw	Go to backweighing function
>Resul	Go to display page for results	Omit.	Omit/include sample
M-init	Input initial weight value	Stat.	View display page for statistics
M-back	Input backweighed residue	Tare	Save tare value
M-tare	Input tare value	>Tare	Go to tare weighing function
Delete	Delete lot/sample	Wt.seq	Select weighing sequence

Direct Selection of Lot/Sample/Value

When the measured values are displayed, you can enter numbers and letters to:

- change the lot and sample directly (displayed in the text line)
- directly access the display pages for samples and values

- Enter lot/sample/value ID

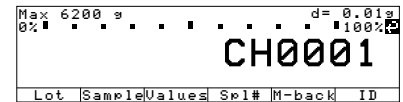

(in this example, “CH0001”, designates a certain lot)

- Press the corresponding soft key

> **Lot** soft key:
The lot corresponding to the ID entered is displayed (if the lot is not found, the display page for lots is shown)

> **Sample** soft key:
The display page is shown for samples in the active lot that contains the sample number entered

> **Values** soft key:
The values for the sample entered are shown

> **Spl#** soft key:
Change samples without the list function

Toggle between Differential Weighing and Basic Weighing:

Press 

Direct Selection of the Weighing Sequence

You can change the weighing sequence (individual weighing, combined weighing, etc.) directly during measurement by pressing the **Wt.seq** key, if this function has been activated in the Setup menu [Application parameters: Application 1: Differential weighing: Weighing sequence key: Yes]

List Function for Differential Weighing

The list function has 4 display pages: one each for lots, samples, values and results.

LOTS:	792	Smp1,avail.
1	1	Sample T
122	1	Sample T,N
RE05	20	Samples T,N,R1
CH0001	10	Samples T,N
CH01234	2	Samples T,N,R1
<<	Delete/Create	^ v Sample

Display Page for Lots

The display page for lots shows all of the lots that have already been created, as well as the number of samples in each lot and the processing status of the selected sample (tare, initial and backweight). On this display page you can create, rename, delete and print lots. You can also define a factor for calculation of loss; for instance, to have weight per unit area calculated (such as grams per square meter). You can also enter a lot ID alphanumerically to access a lot directly.

SAMPL: avail,792	Lot: CH0001
Sample 1:	T,N,R(1) CX07
Sample 2:	T,N,R(1) CX08
Sample 3:	T,N
Sample 4:	T,N
Sample 5:	T,N
<<	Delete ^ v Values

Display Page for Samples

This display page shows the samples contained in a selected lot, as well as the processing status of the samples (tare, initial and backweight) and the sample IDs. You can also enter a sample ID alphanumerically to access a sample directly.

VALUES: Lot: CH0001	Smp1:2
Date,time:	16.11.1998 15:11:17
Name:	ID CX08
Tare:	T1 + 324.72 g
Net initial wt:	N1 + 414.45 g
Backwsh'd res:	R (1)+ 393.55 g
<<	Result ^ v

Display Page for Values

This display page shows the date and time of sampling, as well as the sample ID and the values measured, for a selected sample.

RESULT: Lot: CH0001	Smp1:2
Residue:	R + 20.74 g
Residue:	R + 80.48 %
Loss:	D - 5.03 g
Loss:	D - 19.52 %
Ratio1:	DR + 24.25 %
<<	Values ^ v J

Display Page for Results

This display page shows the calculated values for a selected sample. These include back-weighted residue, loss, loss calculated using a factor, and the ratio values. The \square symbol indicates the value that is selected for display immediately following a backweighing procedure. To change this setting, use the \vee and \wedge soft keys to move the highlight bar to the desired value, and press \downarrow to confirm.

STATISTICS: Lot:CH6789	
Statistics on: R (1) 5 Smp1s	
Statistics on: R (2) 3 Smp1s	
Statistics on: R (*) 8 Smp1s	
<<	^ v J

Display Page for Statistics

This page shows the characteristic data for a lot (date; time; statistics on, for example, the backweighed residue; number of samples) as well as the calculated values (mean value, standard deviation).

STATISTICS: Lot:CH6789	
Date,time:	04.02.1999 14:31:30
Statistics on:	R (1) >Residue<
No.of values:	n 2
Mean value:	Mean + 93.28 %
Std. deviation:	s 0.01 %
<<	s

To select a set of statistics from a lot with different numbers of backweighing procedures: Press the \downarrow soft key to display the selected set of statistics:

Selecting Display Pages in the List Function for Differential Weighing

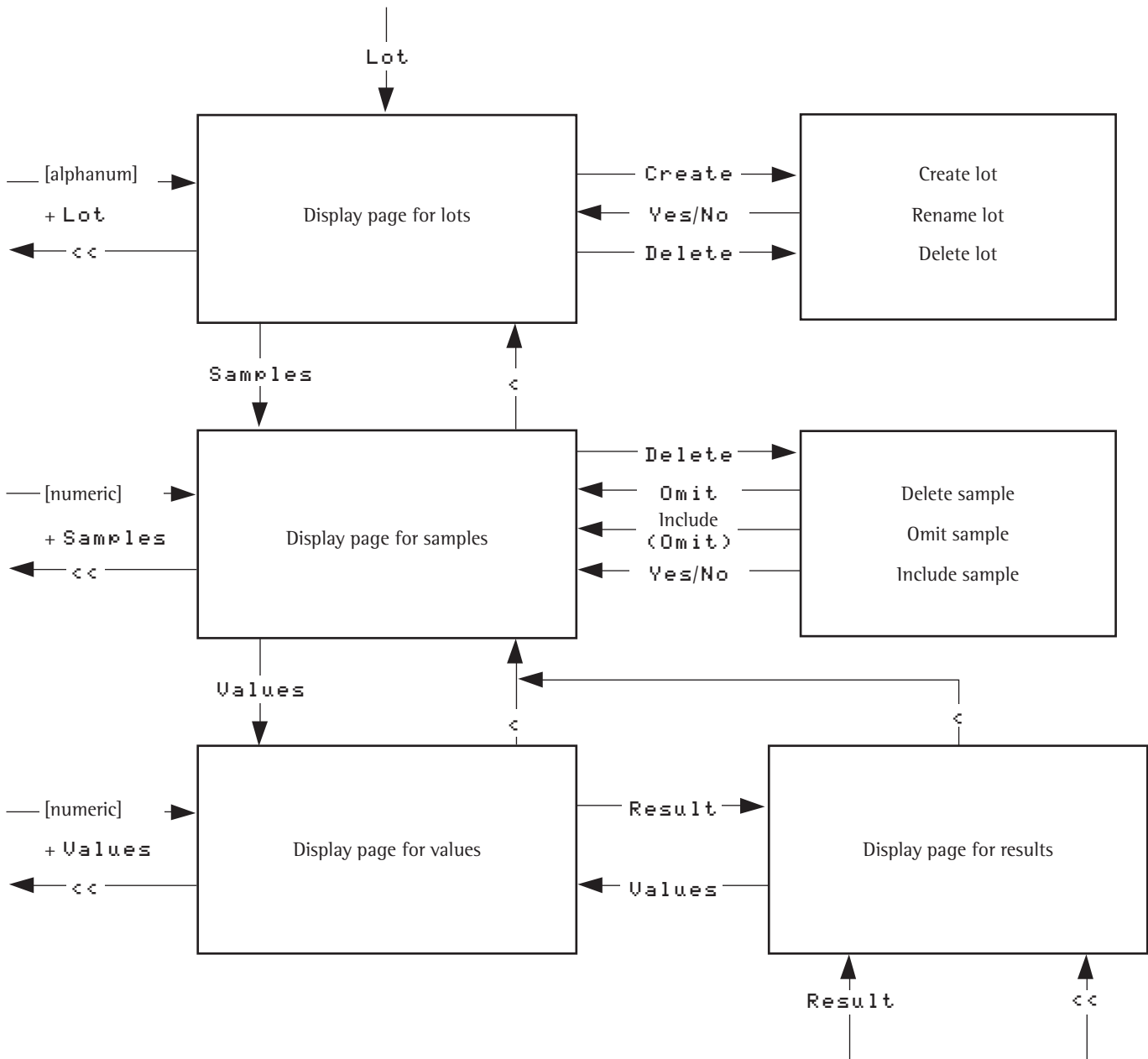

View and Print Display Pages

You can use the manual mode to print display pages (for lots, samples, values and results).

To view and print a display page for values:

- Show the display page for lots: press the **Lot** soft key
- Show the display page for samples: press the **Sample** soft key
- Show the display page for values: press the **Values** soft key
- Print the display page for values: press 

PRINT: Lot: CH0001	Smpl:1
Current sample	
All samples (5)	
<<	<
	v
	↓

- Select amount of data to be included on the printout: press the **v** or **^** soft key
- Confirm print command: press the **↓** soft key

The display pages for lots and samples can be printed when they are shown on the balance display.

View the Display Page for Results:

- Show the display page for lots: press the **Lot** soft key
- Show the display page for samples: press the **Sample** soft key
- Show the display page for values: press the **Values** soft key
- Show the display page for results: press the **Result** soft key
- Print the display page for results: see instructions for printing the display page for values

You can manually print the display page for statistics when it is shown on the balance

To view the display page for statistics:

- Select statistics: press the **Stat.** soft key
- For samples each with a different number of backweights: Select the kind of statistics: press the **v** or **^** soft key
- Confirm selection: press the **↓** soft key

Deleting or Omitting a Lot or Sample

Lots can be deleted; samples can be deleted or omitted.

- You can choose between
 - deleting the current lot and
 - deleting all lots.

- You can choose whether
 - the active sample is deleted entirely, or
 - only the values from the active sample are deleted, or
 - all samples are deleted completely, or
 - only the values from all samples are deleted, or
 - a sample is omitted

Deleting a Lot/Sample

- Activate the display page for lots/samples
- Select the desired lot/sample
- Select the "Delete" function: Press the **Delete** key
- Define the lot(s)/sample(s) to be deleted and confirm
- Select "Yes" to complete the delete function or "No" to cancel it

SAMPLE: confirm deletion	
Complete current sample	
Only values for current sample	
All complete samples (3)	
Only values for all samples (3)	
	No Yes

Example: Deleting all samples completely (in this case, 3 samples)

- Omit or Include Sample
- Activate the display page for samples
- Select the desired (or omitted) sample
- Delete: Press the **Delete** key
- Omit: Press the **Omit** key

SMPL: avail. 991	Lot: MILK123
Sample 1: T.N.R(3)	OK97
Sample 2: T.N.R(1)	OK98
Sample 3: T.N.R(1)	(omitted)
<<	Delete
<	^
	Values



Example: Sample 3 has been omitted

Additional Functions

In addition to the functions for:

- alphanumeric input,
- taring (not during alphanumeric input), and
- printing,





you can also access the following functions from this application:

- Calibration/Adjustment
 - Press the **Cal** soft key
 - > See the section entitled "Calibration/Adjustment" for further instructions
- Setup (Parameter Settings)
 - Press the  key
 - > See the chapter entitled "Configuration" for further instructions
- Turning Off the Balance
 - Press the  key
 - > The balance shuts off



Practical Examples

Combined weighing; create lot, determine the difference in weight between initial weights and backweights of three samples (with autoprnt of the formatted backweighing record)

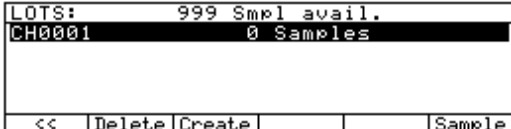
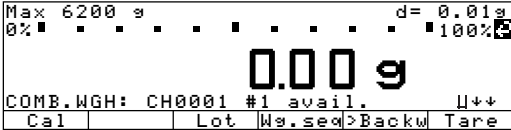
Settings: factory settings

Step	Key (or instruction)	Display/Output
1. Turn on the balance/scale, if necessary		 <p>Max 6200 g d= 0.01g 0% 100% + 0.03 g DIFF.WEIGHING: Combined weigh. Cal Start</p>
2. Tare the balance/scale, if necessary		 <p>Max 6200 g d= 0.01g 0% 100% 0.00 g DIFF.WEIGHING: Combined weigh. Cal Start</p>
3. Start combined weighing	Start soft key	 <p>Max 6200 g d= 0.01g 0% 100% 0.00 g COMB.WGH: Create 1st lot Cal Lot Start</p>
4. Select lot ID input	Lot soft key	 <p>LOT: create lot name Lot name: ██████████ Factor: +1.00000 << v ↓</p>
5. Enter lot ID	  ...   	 <p>LOT: create lot name Lot name: CH0001 Factor: +1.00000 << v ↓</p>
6. Confirm input	↓ soft key	 <p>LOTS: 999 Smpl avail. CH0001 0 Samples << Delete Create Sample</p>
7. Activate weight readout (or toggle to combined weighing)	<< soft key Wt. seq soft key	 <p>Max 6200 g d= 0.01g 0% 100% 0.00 g COMB.WGH: CH0001 #1 avail. ↑↑ Cal Lot Wt.seq>Backw Tare</p>
8. Measure 1st tare weight	Place 1st empty container on balance/scale	 <p>Max 6200 g d= 0.01g 0% 100% + 72.07 g COMB.WGH: CH0001 #1 avail. ↑↑ Cal Lot Wt.seq>Backw Tare</p>
9. Save tare value	Tare soft key Remove the empty container	 <p>Max 6200 g d= 0.01g 0% 100% 0.00 g COMB.WGH: CH0001 #1 T ↑↑ Cal Lot Wt.seq>BackwIni.wt</p>
10. Measure the initial weight (in this case: 24.52 g)	Fill the 1st container Place filled container	 <p>Max 6200 g d= 0.01g 0% 100% + 24.52 g N1 COMB.WGH: CH0001 #1 T ↑↑ Cal Lot Wt.seq>BackwIni.wt</p>

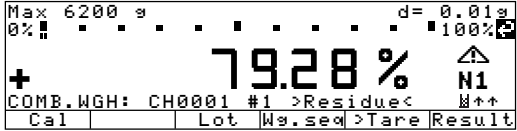
Step	Key (or instruction)	Display/Output
11. Save initial weight value	Ini.wt soft key Remove the filled container	<p>Max 6200 g d= 0.01g 0% 100% 0.00 g COMB.WGH: CH0001 #2 avail. U++ Cal Lot Wg.seq>Backw Tare</p>
12. Measure the 2nd tare weight	Place 2nd empty container on balance/scale	<p>Max 6200 g d= 0.01g 0% 100% + 73.30 g COMB.WGH: CH0001 #2 avail. U++ Cal Lot Wg.seq>Backw Tare</p>
13. Save tare value	Tare soft key Remove the empty container	<p>Max 6200 g d= 0.01g 0% 100% 0.00 g COMB.WGH: CH0001 #2 T W++ Cal Lot Wg.seq>Backw Ini.wt</p>
14. Measure the initial weight (in this case: 22.43 g)	Fill the second container Place filled container on balance/scale	<p>Max 6200 g d= 0.01g 0% 100% + 22.43 g N1 COMB.WGH: CH0001 #2 T W++ Cal Lot Wg.seq>Backw Ini.wt</p>
15. Save initial weight value	Ini.wt soft key Remove the filled container	<p>Max 6200 g d= 0.01g 0% 100% 0.00 g COMB.WGH: CH0001 #3 avail. U++ Cal Lot Wg.seq>Backw Tare</p>
16. Measure the third tare weight	Place 3rd empty container on balance/scale	<p>Max 6200 g d= 0.01g 0% 100% + 72.22 g COMB.WGH: CH0001 #3 avail. U++ Cal Lot Wg.seq>Backw Tare</p>
17. Save tare value	Tare soft key Remove the empty container	<p>Max 6200 g d= 0.01g 0% 100% 0.00 g COMB.WGH: CH0001 #3 T W++ Cal Lot Wg.seq>Backw Ini.wt</p>
18. Measure the initial weight (in this case: 25.79 g)	Fill the container Place filled container on balance/scale	<p>Max 6200 g d= 0.01g 0% 100% + 25.79 g N1 COMB.WGH: CH0001 #3 T W++ Cal Lot Wg.seq>Backw Ini.wt</p>
19. Save initial weight value	Ini.wt soft key Remove the filled container	<p>Max 6200 g d= 0.01g 0% 100% 0.00 g COMB.WGH: CH0001 #4 avail. U++ Cal Lot Wg.seq>Backw Tare</p>
20. Treat the sample		
21. Go to backweighing function	>Backw soft key	<p>Max 6200 g d= 0.01g 0% 100% 0.00 g COMB.WGH: CH0001 #1 T,N W++ Cal Lot Wg.seq>Tare Backw</p>

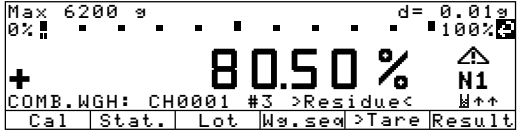
Step	Key (or instruction)	Display/Output
22. Save the 1st backweight is defined (the value to be displayed on the display page for results; in this case: backweighed residue in %)	Place 1st container on balance/scale Backw. soft key	 <pre> ----- 17.11.1998 12:49:23 Lot CH0001 Sample 1 T1 + 72.07 g N1 + 24.52 g R (1)+ 19.44 g R + 79.28 % D - 5.08 g D - 20.72 % Ratio1+ 26.13 % Ratio2+ 126.13 % ----- </pre>
Configured backweighing printout is generated		
23. Save the 2nd backweight	Remove 1st container Place 2nd container Backw. soft key	 <pre> ----- 17.11.1998 12:52:57 Lot CH0001 Sample 2 T1 + 73.30 g N1 + 22.43 g R (1)+ 17.31 g R + 77.17 % D - 5.12 g D - 22.83 % Ratio1+ 29.58 % Ratio2+ 129.58 % ----- </pre>
Configured backweighing printout is generated		
24. Save the 3rd backweight	Remove the 2nd container Place the 3rd container on the balance/scale Backw. soft key	 <pre> ----- 17.11.1998 12:53:23 Lot CH0001 Sample 3 T1 + 72.22 g N1 + 25.79 g R (1)+ 20.76 g R + 80.50 % D - 5.03 g D - 19.50 % Ratio1+ 24.23 % Ratio2+ 124.23 % ----- </pre>
Configured backweighing printout is generated		
25. Unload the balance/scale	Remove the 3rd container	

Checkweighing ✂

Purpose

This program is used to check whether a sample corresponds to a pre-set target value or is within a specific tolerance range. In addition to the display in the measured value line, the results are shown on the bar graph and can also be routed through the interface port via control lines for further electronic processing.

You can use the "Checkweighing" application in combination with a program chosen from Application 1 (e.g., counting, weighing in percent) and one from Application 3 (totalizing, formulation, statistics).

Available Features

- Optional configuration in the Setup menu for long-term storage of target value and tolerance limits
- Optional balance configuration in Setup for automatically initializing this application and loading the values stored in long term memory for the target value and the upper and lower tolerance limits when you turn on the balance
- You can perform checkweighing
 - without entering a target value, but only upper and lower tolerance limits;
 - as differential checkweighing;
 - with symmetric or asymmetric limits which can be entered as percentages
- Enter target value and limits by placing a load on the balance or using the numeric keys
- Control in entering target and tolerance values, so that the upper limit \geq the target \geq the lower limit ≥ 1 display increment
- Accuracy of a weight readout or keyboard input as target/tolerance values corresponds to the display accuracy
- Optional balance configuration in the Setup menu for automatic output to the interface port (print application parameters) of target value and tolerance limits when initialization is completed
- Control range for the balance's data output port lines is 30% to 170% of the target value
- Optional configuration in the Setup menu for activation of control lines dependent on weight value (weight value within control range, stability reached)
- Toggling the display between weight readout and control (checkweighing) display by pressing the corresponding soft key. If the weight value exceeds tolerances, the measured value line shows the weight while the control display shows "LL" for "too low" or "HH" for "too high."
- Press the **Show** soft key to display target value and tolerance limits in the text line after initializing the application.

- Weight value in bar graph displayed in relation to upper and lower limits and target value.
- "OK" value counter displayed in the text line (e.g., $n = 4$). This counter shows the number of measured values that lie within the tolerance range.
- Optional automatic printout of weight value when it is within the control range at stability

After an automatic printout, the balance is blocked. Before you can generate the next printout, you must unblock the balance by unloading it (weight must be under 30% of the target) or by placing a load on the balance (bringing the weight up to at least 170% of the target).

- Press **CF** to delete the initialization parameters and end the Checkweighing program

Factory Settings

Activation of port lines: **Within checkweighing range**

Type of checkweighing input: **Target, minimum, maximum weight**

Weight display mode: **Absolute value**

Automatic printout of OK values: **No**

Soft Key Functions

- | | |
|---------------|---|
| Param. | Begin input of target and tolerance values |
| Show | Display target and tolerance values in turn during checkweighing |
| LLHH | Toggle to control display ("LL" for too light and "HH" for too heavy) |
| Diff. | Display difference between current value and target |
| Net. | Display net weight |

Preparation

The checkweighing program often requires a target value for comparison with the current value. This target has a tolerance range, which is defined by absolute weight values. The tolerance range is defined as either an absolute value or a percentage with upper and lower limits. Percentage values can be symmetric or asymmetric to the target value. These values can be entered either by storing weights on the balance or by key input.

There are four control lines, called data output port lines, which are activated as follows: (see also the diagram at the right):

- lighter
- equal
- heavier
- set

The control range spans 30% to 170% of the target value. You can configure this parameter in the Setup menu (App: Application 2: Checkweighing: Activation of port lines:) to select whether the control lines are:

- activated within the control range
- always on
- activated at stability within the control range
- activated at stability

This makes it possible, for example, to connect a simple indicator for the weighing results (e.g., three different colors, one each for the weighing results: too light, O.K., too heavy).

Response of Control Lines During Checkweighing

- Configurations:
- always on
 - activated at stability

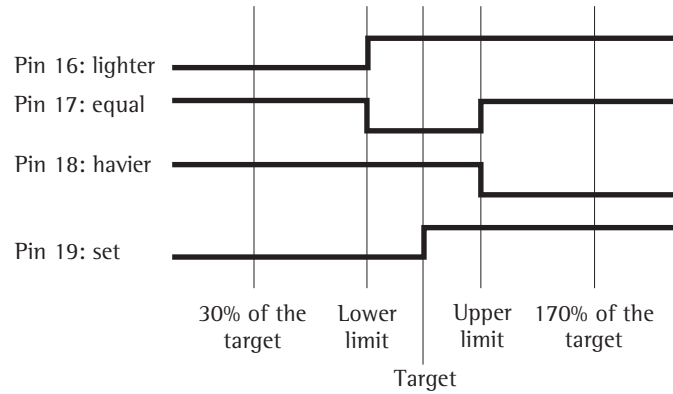

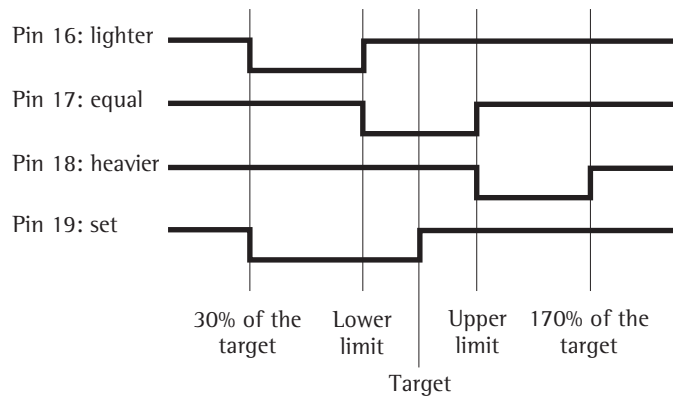

- Configurations:
- activated within control range
 - activated at stability within control range



Output port specifications

- When not in use, the voltage level is high: >2.4 V/+2 mA.
- When activated, the voltage level is low: <0.4 V/-2 mA.
- △ The output ports are not protected against short circuits!

Preparation

- Turn on the balance: Press 
- > Sartorius logo is displayed
- Select the Checkweighing application in the Setup menu: Press 
- Select **Application 2**: Press the ∇ soft key and then the \rightarrow soft key
- Select the **Application parameters**: press the ∇ soft key 2 x, then the \rightarrow soft key
- Select **Application 2 (control functions)**: Press the ∇ soft key, then the \rightarrow soft key
- Select **Checkweighing**: press the Δ or ∇ soft key, repeatedly, if necessary
- Confirm **Checkweighing**: press the \rightarrow soft key

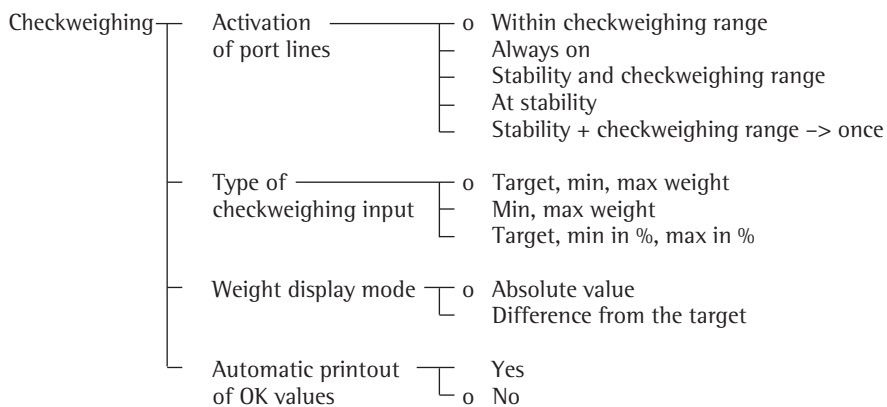

o = factory setting

see also the "Application Parameters (Overview)" in the chapter entitled "Configuration"

- Save settings and exit the Setup menu: press the $\leftarrow \leftarrow$ soft key

Additional Functions

In addition to the functions for:

- alphanumeric input, (not during initialization),
- taring (not during alphanumeric input)
- printing, you can also access the following functions from this application:

Calibration/Adjustment

- Press the **Cal** soft key

- > See "Calibration/Adjustment" for further instructions

Toggling to Another Application

- Press 

- > See the section on the corresponding application program for further instructions

Setup (setting parameters)

- Press 

- > See "Configuration" for further instructions

Turning Off the Balance

- Press 

- > The balance shuts off

- > The display goes blank



Practical Example

Checkweighing samples of 170 g, with an allowable tolerance of -5 g and +10 g. Printout of upper and lower tolerance limits. Weighed values are printed out automatically when stability is reached and weight value is within the control range.

Settings (changes in the factory settings required for this example):

Setup: App: Application 2: Checkweighing: Automatic printout of OK values: Yes

Step	Key (or instruction)	Display/Output
1. Turn on the balance and configure the settings as indicated above		
2. Delete previous setting if necessary		
3. Prepare a container for the samples	Place empty container on the balance	
4. Tare the balance		
5. Enter initialization values	Param. soft key	
6. Enter target value via the balance (here: 170 g)	Place ideal sample in container	
7. Store target value and unload balance	soft key Remove ideal sample from balance	
8. Enter value for lower limit (170 g - 5 g) and store	 soft key	

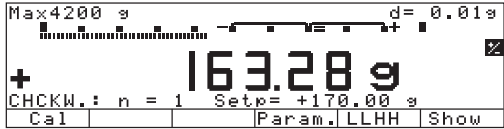
Step	Key (or instruction)	Display/Output									
9. Enter value for upper limit (170 g + 10 g) and store	1 8 0 ↓ soft key	 <table border="1" data-bbox="1015 521 1501 622"> <tr> <td>Setp</td> <td>+</td> <td>170.00 g</td> </tr> <tr> <td>Min</td> <td>+</td> <td>165.00 g</td> </tr> <tr> <td>Max</td> <td>+</td> <td>180.00 g</td> </tr> </table>	Setp	+	170.00 g	Min	+	165.00 g	Max	+	180.00 g
Setp	+	170.00 g									
Min	+	165.00 g									
Max	+	180.00 g									
10. Weigh sample (in this case 169.48 g)	Place sample in container	 <table border="1" data-bbox="1015 844 1501 878"> <tr> <td>N</td> <td>+</td> <td>169.48 g</td> </tr> </table>	N	+	169.48 g						
N	+	169.48 g									
If the weight value had been too low, the display would have shown the following:											
11. In this case, switch to net value display (here: 163.28 g)	Net soft key										
12. Weigh next sample (if any)	Place sample in container										

Time-Controlled Functions

Purpose

With this application program, you can configure the balance to perform certain functions (e.g., automatic printout of values, store value in totalization memory) at a given time or after a set interval.

You can use the “Time-Controlled Functions” application in combination with a program chosen from Application 1 (e.g., counting, weighing in percent) and one from Application 3 (e.g., totalizing, formulation).

Available Features

- Time-controlled activation of balance functions:

- one time only, at a given time

(**Setting=** is displayed in the text line)

- repeatedly, at given intervals

(**Interval=** is displayed in the text line before the function is started, and

Repeat= is displayed after the function is started)

Functions that can be time-controlled include:

- Acoustic signal
- Lock in readout
- Automatic printout of values
- Store values for totalizing, formulation or statistics
- Print time in addition to weight value
- Store value independent of stability
- Tare the balance after printout of weight values
- Press the corresponding soft key to cancel time-controlled functions

Factory Settings

Function after time interval:
Automatic printout of values

Automatic function restart: **On**

Storage mode:
Without stability

Print then tare: **On**

Soft Key Functions

Stop Stop the application

Quit Confirm performed function (e.g., “Lock in readout” or “Beep”)

Interv Store input interval for time-controlled functions

Set. Store input time for one-time performance of function

Preparation

- Turn on the balance: Press 

> Sartorius logo is displayed

- Select the “Time-controlled functions” application in the Setup menu: Press 

- Select the **Application parameters**: press the ∇ key 2 x, then the \rightarrow soft key

- Select **Application 2 (control functions)**: press the ∇ soft key, then the \rightarrow soft key

- Select **Time-controlled functions**: press the \wedge or ∇ soft key

- Confirm **Time-controlled functions**: press the \rightarrow soft key

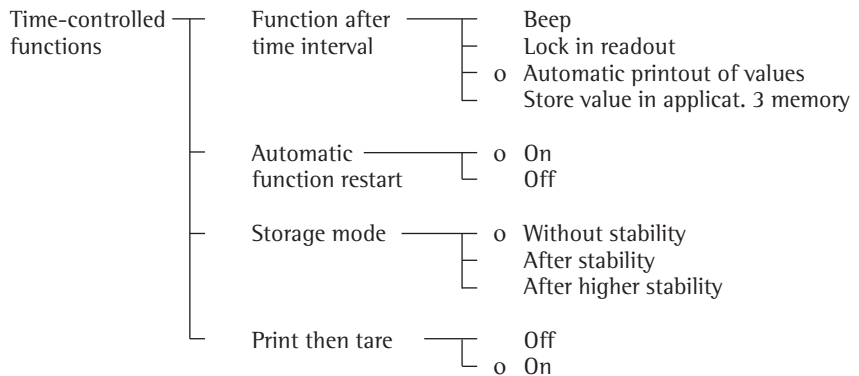

o = factory setting

see also the “Application Parameters (Overview)” in the chapter entitled “Configuration”

- Save settings and exit the Setup menu: press the \ll soft key

Print Net Values without Printout of Time

Select the Setup menu:

Setup: Printout: Application-defined output: Auto print upon initialization: Off

Practical Example











Document the amount of evaporation of a sample with defined surface, temperature and air pressure at preset intervals of 1 minute, 30 seconds.

Settings (changes in the factory settings required for this example):





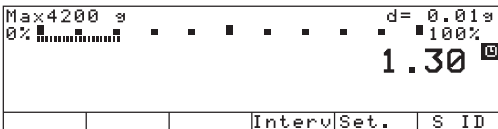

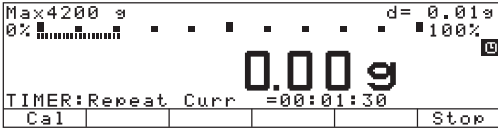

Setup: App: Application 2: Time-controlled functions

Setup: Balance functions: Taring: Without stability

Setup: Print in weighing mode: Manual/auto print mode: Manual without stability

Step	Key (or instruction)	Display/Output
1. Turn on the balance and configure the settings as indicated above		
2. Delete stored values if necessary		
3. Place container with sample on the balance and tare		
4. Enter time interval: 1 minute, 30 seconds	   	
5. Store time interval	Interv soft key	
6. Begin documentation (Time remaining until the next printout is displayed in the text line)	Start soft key	
Printout of evaporation amount every 1½ minutes		<pre> Time: 15:19:50 N - 0.37 g Time: 15:21:20 N - 0.33 g Time: 15:22:50 N - 0.30 g Time: 15:24:20 N - 0.40 g </pre>
7. Stop the documentation procedure	Stop soft key	

Preparation

- Turn on the balance: Press 
- > Sartorius logo is displayed
- Select the Totalizing application program in the Setup menu: Press 
- **Anwendungsparameter** wählen: 2 x Softkey  , Softkey  drücken
- Select the **Application parameters**: press the  soft key 2 x, then the  soft key
- Select **Totalizing**: press the  or the  soft key
- Select **Totalizing**: press the  soft key

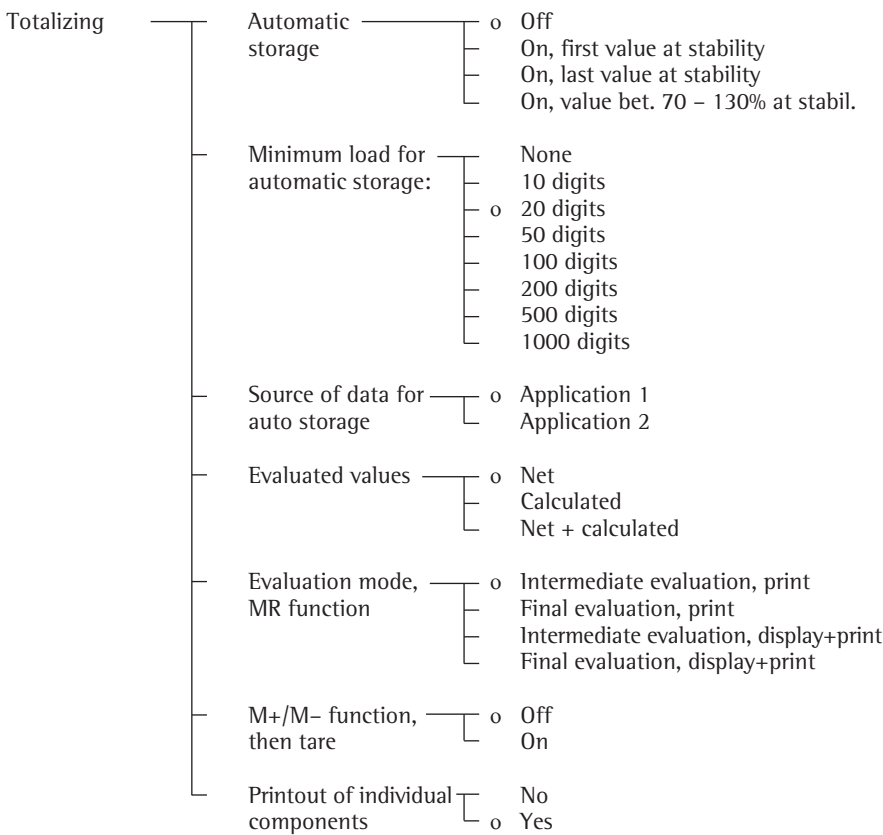

o = factory setting

see also the “Application Parameters (Overview)” in the chapter entitled “Configuration”

- Save settings and exit the Setup menu: press the  soft key

Additional Functions

In addition to the functions for:

- alphanumeric input,
- taring (not during alphanumeric input),
- printing,

you can also access the following functions from this application:

Calibration/Adjustment

- Press the **Cal** soft key
- > See “Calibration/Adjustment” for further instructions

toggling to Another Application

- Press 
- > See the section on the corresponding application program for further instructions

Setup (setting parameters)

- Press 
- > See “Configuration” for further instructions

Turning Off the Balance

- Press 
- > The balance shuts off

Practical Example







Totalize counted pieces



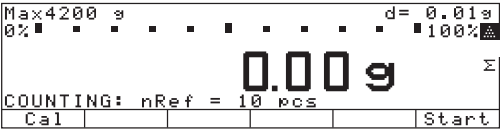
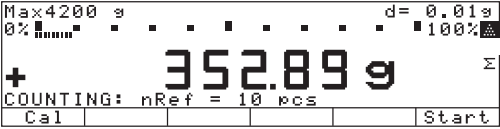
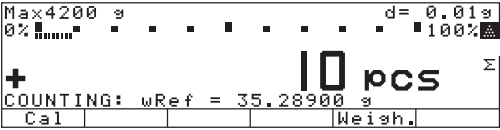

Settings (changes in the factory settings required for this example):

Setup: App: Application 1: Counting

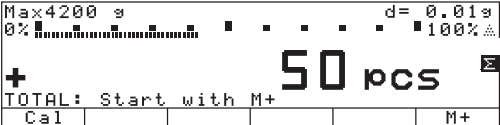
Setup: App: Application 3: Totalizing: Evaluated values: Net + calculated

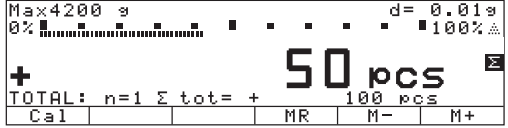
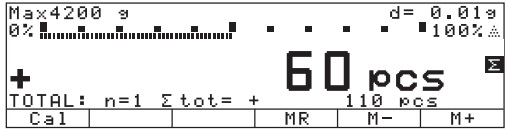
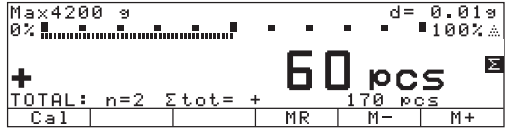
Setup: App: Application 3: Totalizing: Evaluation mode, MR function: Final evaluation, display + print

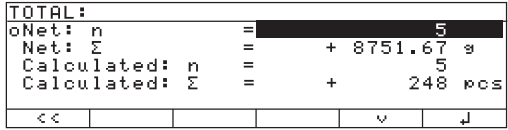
Step	Key (or instruction)	Display/Output				
1. Turn on the balance and configure the settings as indicated above						
2. Delete old totalization data, if necessary						
3. Tare the balance						
4. Toggle to Application 1: Counting						
5. Place the displayed number of parts on the balance (here: 10 pcs)	Place parts to be counted on the balance					
6. Initialize the Counting application	Start soft key	 <div style="border: 1px solid black; padding: 5px; margin: 5px 0;"> <table style="width: 100%; border-collapse: collapse;"> <tr> <td style="padding: 2px;">nRef</td> <td style="padding: 2px;">10 pcs</td> </tr> <tr> <td style="padding: 2px;">wRef</td> <td style="padding: 2px;">35.28900 g</td> </tr> </table> </div>	nRef	10 pcs	wRef	35.28900 g
nRef	10 pcs					
wRef	35.28900 g					
7. Remove the reference sample quantity and toggle to Totalizing	Unload the balance 					
8. Place a number of parts on the balance (here: 50 pcs)	Place parts on the balance					

Step	Key (or instruction)	Display/Output
9. Store piece count	M+ soft key	 <pre> Max4200 g d= 0.01g 0% ██████████ 100%▲ + TOTAL: n=1 Σ tot= + 100 pcs Cal MR M- M+ </pre> <pre> ----- 16.01.1997 11:06 n + 1 N + 1764.45 g Qnt + 50 pcs </pre>
10. Unload the balance	Remove parts from the balance	
11. Place another load of parts on the balance (e.g., 60 pcs)	Place parts on the balance	 <pre> Max4200 g d= 0.01g 0% ██████████ 100%▲ + TOTAL: n=1 Σ tot= + 160 pcs Cal MR M- M+ </pre>
12. Add piece count to stored total	M+ soft key	 <pre> Max4200 g d= 0.01g 0% ██████████ 100%▲ + TOTAL: n=2 Σ tot= + 170 pcs Cal MR M- M+ </pre> <pre> n + 2 N + 2117.34 g Qnt + 60 pcs </pre>
13. Repeat steps 10 and 11 as required		
14. Display final evaluation ("Info" window) (here: 5 weighing operations; total weight: 8751.67 g; total quantity: 248) The  indicates which value is displayed in the text line; you can change this selection	MR soft key	 <pre> TOTAL: oNet: n = 5 Net: Σ = + 8751.67 g Calculated: n = 5 Calculated: Σ = + 248 pcs << v ↓ </pre>
15. Print final evaluation		<pre> ----- n 5 Total + 8751.67 g Total + 248 pcs 16.01.1997 11:16 ----- </pre>

Formulation

Purpose

With this application program you can add weight values and calculated values to a totalization memory as components of a formula.

You can use the "Formulation" application in combination with a program chosen from Application 1 (except Recalculation) and one from Application 2 (checkweighing, time-controlled functions) as well as with the extra functions.

Available Features

- Totalization of weight values and calculated values
- Weigh in different components to a total amount defined by pressing the **nom** soft key and entering the value through the numeric keys
- Simultaneous storage of net and calculated values
- Optional configuration in the Setup menu for loading weight values and calculated values either from Application 1 (e.g., counting, weighing in percent) or from Application 2 (checkweighing, time-controlled functions)
- Totalization memory for up to 65535 values
- Transaction counter and current total displayed in the text line
- Balance tared after a value is stored
- Manual input of the number of individual weighing operations (target no. of operation **nDef**). Result printed and memory cleared after printout of **nDef**.
- Optional configuration in the Setup menu to add the current weight, with display accuracy, to the current total by pressing the **M+** soft key and generating a printout of the result
- Optional configuration in the Setup menu for stability-dependent storage of the measured value: **Stability range**
- Optional automatic storage of measured values

Storage of measured value is indicated by $\rightarrow \leftarrow$.

\leftrightarrow indicates that you can place a load on the balance.

- Minimum load threshold for automatic storage
- Press the **M-** soft key to delete the last value added to the totalization memory. The transaction counter value is reduced by one and a printout is generated.
- Printout of an evaluation of results, depending on the Application 1 or Application 2 parameters. Configure the Setup menu to define the information included on this printout.
- Press the key identified by **MR** (soft key) for a printout of an intermediate evaluation after each addition or a final evaluation
- A final evaluation is printed when the formulation routine is ended by pressing **CF**, if no final evaluation was generated by pressing **MR**
- Optional configuration in the Setup menu to clear the totalization memory and reset the transaction counter by pressing **CF** or after an evaluation is printed out
- Totalization data and transaction counter data are stored in non-volatile memory
- Continue formulation after turning the balance off and back on

Factory Settings

Automatic storage: **Off**

Minimum load for automatic storage: **20 digits**

Source of data for auto storage: **Application 1**

Evaluated values: **Net**

Evaluation mode, MR key function: **Intermediate evaluation, print**

Printout of individual components: **On**

Balance functions: Stability range: **2 digits**

Printout: Application-defined output: Print on request, then tare: **Off**

Soft Key Functions

M+ Add weight values or application values to the total in the totalization memory. The component or transaction counter value increases by one each time you press this key.

M- Delete the last value added to memory. The transaction counter value decreases by 1. You cannot delete previous values by repeatedly pressing this key.

MR Print or display an intermediate or final evaluation

nDef Store the input number of component

nom Press to enter target component weight using the numeric keys



Printout of Formulation Report

When an intermediate or final evaluation is printed out, all results up to this point are included.

Comp2 + 42.38 g
Tot.cp+184.89 g

Comp2: Weight of the 2nd component
Tot.cp: Total of all components

Preparation

- Turn on the balance: Press 
- > Sartorius logo is displayed
- Select the Formulation application program in the Setup menu: Press 
- Select **Application parameters**: press the ∇ soft key 2 x, then the \rightarrow soft key once
- Select **Application 3 (data records)**: press the ∇ soft key 2 x, then the \rightarrow soft key once
- Select **Formulation**: press the \wedge or the ∇ soft key
- Select **Formulation**: press the \rightarrow soft key

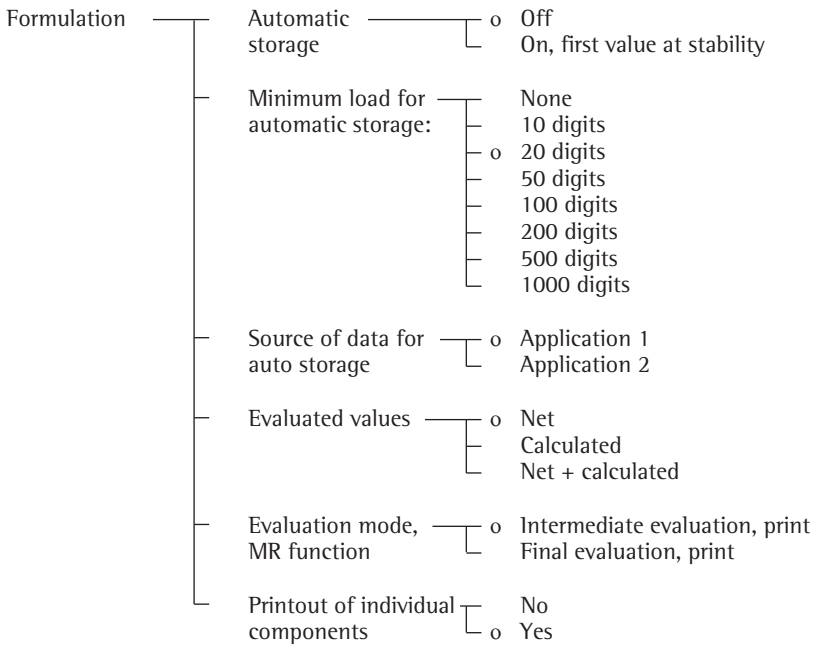

o = factory setting

see also the “Application Parameters (Overview)” in the chapter entitled “Configuration”

- Save settings and exit the Setup menu: press the $\leftarrow \leftarrow$ soft key

Additional Functions

- In addition to the functions for:
- alphanumeric input,
 - taring (not during alphanumeric input),
 - printing,

you can also access the following functions from this application:

- Calibration/Adjustment
- Press the **Cal** soft key

- > See “Calibration/Adjustment” for further instructions

Switching to Another Application

- Press 
- > See the section on the corresponding application program for further instructions

Setup (setting parameters)

- Press 
- > See “Configuration” for further instructions

Turning Off the Balance

- Press 
- > The balance shuts off

Practical Example







Weighing in Components

Settings (changes in the factory settings required for this example):

Setup: App: Application 3: Formulation: Automatic storage: On, first value at stability

Setup: App: Application 3: Formulation: Minimum load for automatic storage: 100 digits

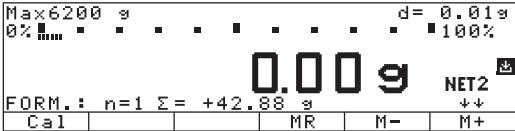
Setup: App: Application 3: Formulation: Evaluation mode, MR function: Final evaluation, print

Step	Key (or instruction)	Display/Output
1. Turn on the balance and configure the settings as indicated above		
2. Delete old formulation data, if necessary		
3. Tare the balance		
4. Place the empty container on the balance (here: 180.59 g)	Place load on the balance	
5. Tare the balance		
6. Weigh in the first component (here: 42.88 g)	Place components in container	
7. Store components in the formulation memory Balance is tared automatically	M+ soft key	
Components are printed out automatically		<pre> ----- 16.01.1997 14:04 Comp1 + 42.88 g </pre>
8. Weigh in the next component (here: 50.80 g) Components are stored in the totalization memory at stability and printed out	Place components in container	<pre> Comp2 + 50.80 g </pre>
Balance is tared automatically		
9. Repeat step 7 as required		
10. Print final evaluation (here: with total weight of all components: 212.43 g)	MR soft key	<pre> ----- n 2 Tot.cp+ 212.43 g 16.01.1997 14:10 ----- </pre>
11. Delete old formulation data, if necessary		

Statistics

Purpose

With this application program you can have weight values and calculated values totalized and statistically evaluated.

The values determined for the evaluation are:

- average
- standard deviation
- variation coefficient
- sum of all values
- lowest value (minimum)
- highest value (maximum)
- difference between the minimum and the maximum

You can use the "Statistics" application in combination with a program chosen from Application 1 (e.g., counting, weighing in percent) and one from Application 2 (checkweighing, time-controlled functions) as well as with the extra functions.

Available Features

- Storage of weight values and calculated values
- Simultaneous storage of net and calculated values
- Optional configuration in the Setup menu for loading weight values and calculated values either from Application 1 (e.g., counting, weighing in percent) or from Application 2 (checkweighing, time-controlled functions)
- Totalization memory for up to 65535 values
- Simultaneous display in the text line of transaction counter and, e.g., the current total
- Optional configuration in the Setup menu for having the balance tare automatically after a value is stored in the totalization memory
- Manual input of the number of individual weighing operations (target no. of operation **nDef**). Result printed and memory cleared after printout of **nDef**.

- Optional configuration in the Setup menu to add the current weight, with display accuracy, to the current total by pressing the **M+** soft key and generate a printout of the result
- Optional configuration in the Setup menu for stability-dependent storage of the measured value: **Stability range**
- Optional automatic storage of measured values

Storage of measured value is indicated by $\rightarrow\leftarrow$.
 $\leftarrow\leftarrow$ indicates that you can place a load on the balance.
- Minimum load threshold for automatic storage
- Press the **M-** soft key to delete the last value added to the totalization memory. The transaction counter value is reduced by one and a printout is generated.
- Press the **MR**: soft key for information about number of transactions and the current total. By configuring the Setup menu, you can define whether the information is displayed and printed, or only printed, and whether the information comprises an intermediate or final evaluation (see the example)
- In the Info window you can use the ∇ , \blacktriangledown soft keys to choose which value is displayed in the text line during weighing
- Printout of the end result depending on the Application 1 or Application 2 parameters. Configure the Setup menu to define which values are included on the printout (Printout of individual components)
- Press **MR** for a printout of an intermediate evaluation after each addition or a final evaluation
- A final evaluation is printed when the statistics routine is ended by pressing **CF**, if no final evaluation was generated by pressing **MR**

- Optional configuration in the Setup menu to clear the totalization memory and reset the transaction counter by pressing **CF** or after an evaluation is printed out
- Totalization data and transaction counter data are stored in non-volatile memory
- Continue totalization after turning the balance off and back on

Factory Settings

Automatic storage: **Off**

Minimum load for automatic storage: **20 digits**

Source of data for auto storage: **Application 1**

Evaluated values: **Net**

Evaluation mode, MR key function: **Intermediate evaluation, print**

M+/M- function, then tare: **Off**

Printout of individual components: **Off**



Balance function: Stability range: **2 digits**

Printout: Application-defined output: Print on request, then tare: **Off**

Soft Key Functions

- M+** Add weight values or application values to the total in the totalization memory. The component or transaction counter value increases by one each time you press this key.
- M-** Delete the last value added to memory. The transaction counter value decreases by 1. You cannot delete previous values by repeatedly pressing this key.
- MR** Print or display an intermediate or final evaluation
- nDef** Store the input number of components

Preparation

- Turn on the balance: Press 
- > Sartorius logo is displayed
- Select the Statistics application program in the Setup menu: Press 
- Select **Application parameters**: press the ∇ soft key 2 x, then the \rightarrow soft key once
- Select **Application 3 (data records)**: press the ∇ soft key 2 x, then the \rightarrow soft key once
- Select **Statistics**: press the \wedge or the ∇ soft key
- Select **Statistics**: press the \rightarrow soft key

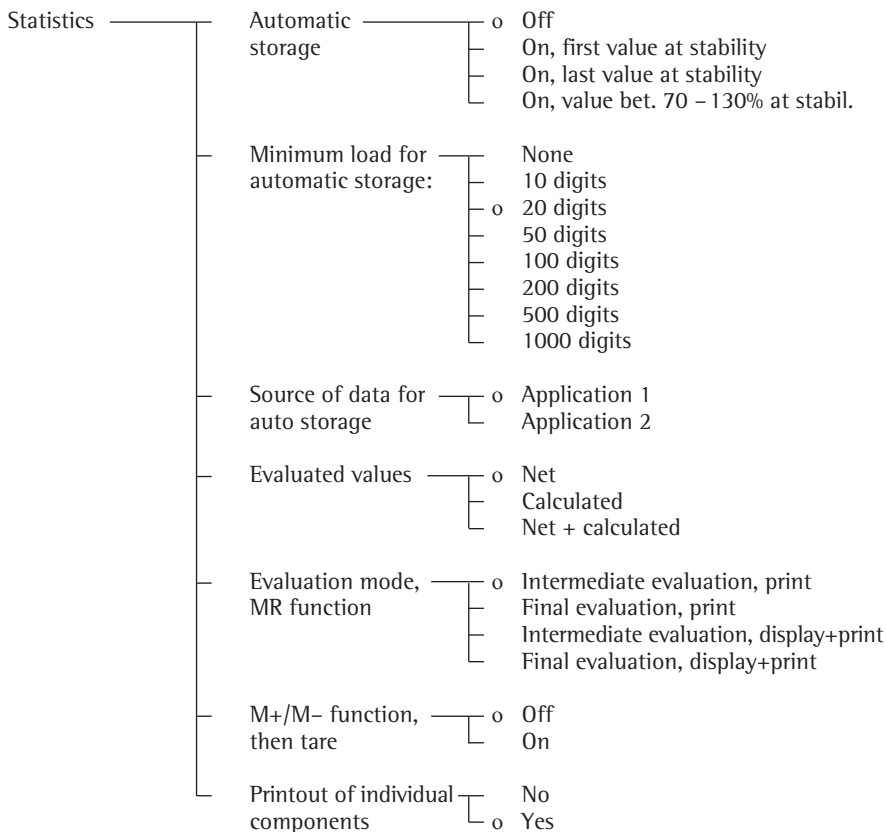

= factory setting

see also the “Application Parameters (Overview)” in the chapter entitled “Configuration”

- Save settings and exit the Setup menu: press the $\leftarrow \leftarrow$ soft key

Additional Functions

In addition to the functions for:

- alphanumeric input,
 - taring (not during alphanumeric input),
 - printing,
- you can also access the following functions from this application:

Calibration/Adjustment

- Press the **Cal** soft key

> See “Calibration/Adjustment” for further instructions

Toggleing to Another Application

- Press 

> See the section on the corresponding application program for further instructions

Setup (setting parameters)

- Press 

> See “Configuration” for further instructions

Turning Off the Balance

- Press 

> The balance shuts off

Practical Example





Totalize counted pieces and print out statistics

Settings (changes in the factory settings required for this example):

Setup: App: Application 1: Counting: Average piece weight updating: Manual

Setup: App: Application 3: Statistics: Evaluated values: Calculated

Setup: App: Application 3: Statistics: Evaluation mode, MR function: Final evaluation, display + print

Step	Key (or instruction)	Display/Output				
1. Turn on the balance and configure the settings as indicated above						
2. Delete old statistics data, if necessary						
3. Tare the balance						
4. Toggle to Application 1: Counting						
5. Place the displayed number of parts on the balance (here: 10 pcs)	Place parts to be counted on the balance					
6. Initialize the Counting application	Start soft key	 <table border="1" style="margin-left: auto; margin-right: auto;"> <tr> <td>nRef</td> <td>10 pcs</td> </tr> <tr> <td>wRef</td> <td>10.62600 g</td> </tr> </table>	nRef	10 pcs	wRef	10.62600 g
nRef	10 pcs					
wRef	10.62600 g					
7. Remove the reference sample quantity and toggle to Statistics	Unload the balance 					
8. Place a number of parts on the balance (here: 35 pcs)	Place parts on the balance					

Additional Functions

Second Tare Memory (Preset Tare)

Purpose

With this function you can store the weight currently on the balance as a tare weight, or use the numeric keys to enter a number for a preset tare weight.

You can use “Extra Functions” in combination with a program from Application 1 (e.g., counting, weighing in percent), one from Application 2 (checkweighing, time-controlled functions) and one from Application 3 (totalizing, formulation, statistics) as well as with the extra functions.

Available Features

- Store a weight on the balance in the second tare memory (without numeric input)
- Store a numeric value in the second tare memory (input using the numeric keys)
- Label a net value as **NET1** when there is a value stored in the second tare
- You can assign this function to the fourth or fifth soft key (from the right), i.e. F4 or F5

The soft key designation for this function is: **PT1 / T1**

- Optional configuration in the Setup menu for storing the current weight readout as the container tare weight. Any load subsequently placed on the scale that is more than 70% of the tare weight is automatically recognized as a container and the scale is tared automatically.
- Automatic printout when a value is stored or input (see “Configuration”)
- Press **CF** to delete the (preset) tare value

Factory Settings

Container tare weight: **No**

Automatic printout: **Off**

Soft Key Functions

PT1 / T1 Store weight as tare value

PT1 Save tare weight entered using the numeric keys

Printout of the Data in the 2nd Tare Memory

The printout shows either

- Net value **N1**
- Tare weight **T1**, or
- Manually entered tare value **PT1**

N1 **163.48 g**
T1 **138.73 g**
PT1 **150.00 g**

N1: Net weight /value) when a weight is stored in the tare memory

T1: Tare weight

PT1: Preset tare value entered using the numeric keys

Preparation

- Turn on the balance: Press **ON**
- > Sartorius logo is displayed
- Select Extra function (F4) or Extra function (F5) in the Setup menu: Press **Setup**
- Select **Application parameters**: press the **v** soft key 2 x, then the **>** soft key once
- Select **Extra function (F4) or Extra function (F5)**: press the **v** soft key 3 x, then press the **>** soft key once
- Select **2nd tare memory**
- Confirm **2nd tare memory**

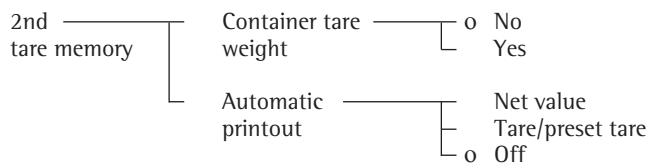

o = factory setting

see also “Application Parameters (Overview)” in the chapter entitled “Configuration”

- Save settings and exit the Setup menu: press the **<<** soft key

Second Tare Memory in Legal Metrology



- Press the **< i > PT1** soft key to enter information about the tare value using the number keys.
- The PT1 tare value is printed out with the net value.

Practical Example

Determine the Contents of Bottles: Bottle weight = 400 g.

Settings (changes in the factory settings required for this example):

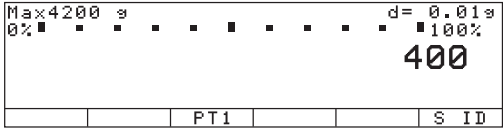
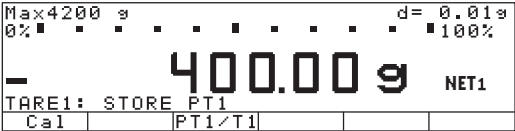
Setup: App: Extra function(F4): 2nd tare memory: Automatic printout: Tare/preset tare

Step	Key (or instruction)	Display/Output
1. If necessary: turn on the balance and enter the settings given above	ON	
2. Enter bottle weight (here: 400 g)	$\text{4} \text{ 0} \text{ 0}$	 <p>Max 4200 g d= 0.01g 0% 100% 400 PT1 S ID</p>
3. Store tare value	PT1 soft key	 <p>Max 4200 g d= 0.01g 0% 100% - 400.00 g NET1 TARE1: STORE PT1 Cal PT1/T1</p> <p style="text-align: center;"> PT1 + 400.00 g </p>
4. Determine content weight of bottles (here: contents = 650 g)	Place filled bottles on the balance	 <p>Max 4200 g d= 0.01g 0% 100% + 650.00 g NET1 Cal PT1/T1</p>

Individual Identification Codes (ID)

Purpose

With this function you can assign identifiers to values for documentation and printouts.

You can use this extra function in combination with a program from Application 1 (e.g., counting, weighing in percent), one from Application 2 (checkweighing, time-controlled functions) and one from Application 3 (totalizing, formulation, statistics) as well as with the other extra functions.

Available Features

- Store up to 4 IDs; these can be stored, changed or deleted individually.
- Each ID consists of a name and a value; both can be defined by the user.
- ID designations are configured in the Setup: Input menu.
- Each ID designation can have up to 20 characters; when you enter the value later, however, no more than 15 characters of the designation are displayed.
- The ID values are entered while the application program is active; press the **ID** soft key to toggle to the ID input mode.
- Each ID value can have up to 20 characters.
- Access 1 of the 4 IDs directly using the numeric keys. The other three can only be accessed by pressing the **ID** soft key to toggle to the identifier input mode.

- You can assign this function to the fourth or fifth soft key (from the right), i.e. F4 or F5.
- You can configure when the ID is included on the printout (see "Preparation," next page).
- You can configure the position of IDs on the individual or total printout.
- The designation is printed flush left; the value flush right. If the name and value together are too long for one line, the data is printed on two lines.
- Optional configuration in the Setup menu to delete a single character when entering an identifier by pressing **CF**. Setup: Device: Keys: CF function for input: Delete last character
- Press the **Delete** soft key to delete an ID

Factory Settings for ID Designations

ID1: **ID 1**
ID2: **ID 2**
ID3: **ID 3**
ID4: **ID 4**

Factory Settings for ID Values

No values set

Factory Settings for Other Parameters

Printout:



**E a c h t i m e t h e p r i n t k e y
i s p r e s s e d**

Soft Key Functions

ID Toggle to "Identification codes" menu

Delete Delete input of selected ID

Preparation

- Turn on the balance: Press 
- > Sartorius logo is displayed
- Select Extra function (F4) or Extra function (F5) in the Setup menu: Press 
- Select **Application parameters**: press the \downarrow soft key 2 x, then the \rightarrow soft key once
- Select **Extra function(F4) or Extra function(F5)**: press the \downarrow soft key 3 x (or 4 x), then the \rightarrow soft key once
- Select **Identification codes**
- Confirm **Identification codes**

Identification codes	Printout	Automatic, if configured
		Once after pressing print, if configured
		o Each time the print key is pressed
		Once for M+ function (app.3 memory)

o = factory setting

see also “Application Parameters (Overview)” in the chapter entitled “Configuration”

- Save settings for the printout: press the \leftarrow soft key 4 x
- Enter ID name: Select “Printout”: press the \downarrow soft key, then the \rightarrow soft key
- Select “Identification #”: press the \downarrow soft key 5 x, then the \rightarrow soft key once
- Select **ID1**
- Enter name for **ID1** and confirm: use the numeric keys for numbers and/or the soft keys to enter letters
- Enter names for **ID2**, **ID3** and **ID4**, if desired
- Save settings and exit the Setup menu: press the $\leftarrow \leftarrow$ soft key

Example

See next page

Example

Include company address and sample lot number on the printout. Each ID line begins with the name. Print this ID for each net value.

Settings (changes in the factory settings required for this example):

- Setup: Application parameters: Extra function (F4): Identification codes
- Setup: Input: ID1: Company
- Setup: Input: ID2: Location
- Setup: Input: ID3: Street
- Setup: Input: ID4: Lot

Step	Press key(s) (or follow instructions)	Display/Output
1. If necessary, turn on the balance	ID	
2. Select "Extra Function (F4)" in the Setup menu	Setup ↓ soft key 2 x, then → soft key once ↓ soft key 3 x, then → soft key once	<pre> SETUP APPLICATION EXT.FCT.F4 oOff 2nd tare memory Identification codes Man. store in app.3 memory (M+) Product data memory << < v ↓ </pre>
3. Select "Identification codes"	↓ or ^ soft key; repeatedly, if necessary	<pre> SETUP APPLICATION EXT.FCT.F4 oOff 2nd tare memory Identification codes Man. store in app.3 memory (M+) Product data memory << < ^ v > </pre>
4. Confirm "Identification codes" and exit this menu item	→ soft key; then ← soft key 3 x	<pre> APPLICATION EXT.FCT.F4 IDENTIFIER Printout << < > </pre>
5. Select ID1 (Printout: Identifier)	↓ or → soft key ↓ soft key 5 x, then → soft key, then ↓ soft key	<pre> SETUP PRINTOUT IDENTIFIER Lot (L ID): ID1: ██████████ ID1 ID2: ██████████ ID2 ID3: ██████████ ID3 ID4: ██████████ ID4 << < ^ v </pre>
6. Enter name for ID 1 (in this case: COMPANY and confirm)	ABC ... see also page 37 ABC , ↓ soft key	<pre> SETUP PRINTOUT IDENTIFIER Lot (L ID): ID1: ██████████ COMPANY ID2: ██████████ ID2 ID3: ██████████ ID3 ID4: ██████████ ID4 ABCDEF GHIJKL MNOPQR STUVWX YZ/=-? :##"§ </pre>

Saving Values Manually (M+)

Purpose

With this function you can load weight values and calculation results directly from Application 1 (e.g., counting, weighing in percent) or Application 2 (checkweighing, time-controlled functions) into Application 3 (totalizing, formulation, statistics).



Available Features

- You can assign this function to the fourth or fifth soft key (from the right), i.e. F4 or F5
The soft key designation for this function is: **M+**
- An Application 3 program (totalizing, formulation or statistics) must be running so you can display and print the result

Factory Settings

There are no optional parameters

Preparation

- Turn on the balance: Press 
- > Sartorius logo is displayed
- Select Extra function (F4) or Extra function (F5) in the Setup menu:
Press 
- Select **Application parameters**: press the ∇ soft key 2 x, then the \triangleright soft key
- Select **Extra function (F4) or Extra function (F5)**:
press the ∇ soft key 3 x (or 4 x), then the \triangleright soft key once
- Select **Man. store in app.3 memory (M+)**
- Confirm **Man. store in app.3 memory (M+)**

See also “Application Parameters (Overview)” in the chapter entitled “Configuration”
- Save settings and exit the Setup menu: press the \ll soft key

Product Data Memory

Purpose

With this function you can enter, store and load data records for initialization of applications, including user-defined data.

You can use this extra function in combination with a program from Application 1 (e.g., counting, weighing in percent), one from Application 2 (checkweighing, time-controlled functions) and the other extra functions for F4 and F5 (identification codes, 2nd tare memory).

Available Features

- Store up to 300 data records.
- Data records can be created, stored or deleted individually.
- Press the **ProDat** soft key to display product data.
- Define a name for each data record of up to 15 alphanumeric characters.
- Optional configuration in the Setup menu to delete a single character when entering a data record name by pressing **CF**. Setup: Device: Keys: CF function for input: Delete last character.
- Data records are displayed in alphabetical order.
- Initialization data set for an application (such as wRef, nRef) is saved when you select the Store option. With several applications and extra functions active, you can select the desired parameters before saving the data to define initialization data.
- Use the alphanumeric keypad to search for and display individual data records.
- You can assign this function to the fourth or fifth soft key (from the right), i.e. F4 or F5.

- Error messages are displayed in the text line in plain English.
- Press the **Delete** soft key to delete a data record.

Data Battery-Backed Data Memory
When the balance is disconnected from AC power, these balance-generated data will remain stored for approx. three months. In the standby mode, data are retained by the power supply.

Factory Settings

No user-definable parameters.

Soft Key Functions

ProDat Toggle to product data display

Delete Delete selected data record

Load Overwrite the initialization data with the selected data record

Change Change the data in the stored data record

Store Store the initialization data of the selected application under the chosen data record name. If data already exist for this data record, a prompt asks whether this data should be overwritten.

No Answer no to cancel a “delete” or “overwrite” operation

Yes Answer yes to perform the “delete” or “overwrite” operation

New Create a new data record (after entering a data record name) and selecting an application, if desired).

Preparation





- Turn on the balance: Press **UO**
- > Sartorius logo is displayed
- Select **Extra function (F4)** or **Extra function (F5)** in the Setup menu: Press **Setup**
- Select **Application parameters**: press the **v** soft key 2 x, then the **>** soft key
- Select **Extra function (F4)** or **Extra function (F5)**: press the **v** soft key 3 x (or 4 x), then the **>** soft key
- Select **Product data memory**
- Confirm **Product data memory**
See also “Application Parameters (Overview)” in the chapter entitled “Configuration”
- Save settings and exit the Setup menu: press the **<<** soft key

Practical Example

Create a New Base Data Record for Initializing the Checkweighing Program, Including: Target Value, Minimum, Maximum

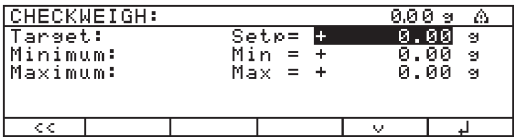
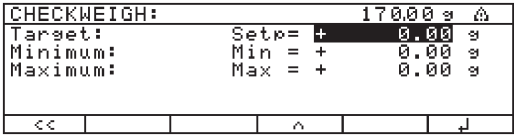
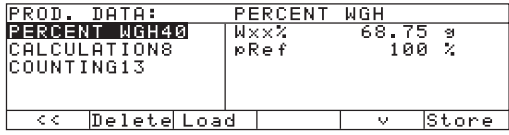
Settings (changes in the factory settings required for this example):

Setup: App: Extra function (F4): Product data memory
 Setup: App: Application 2: Checkweighing

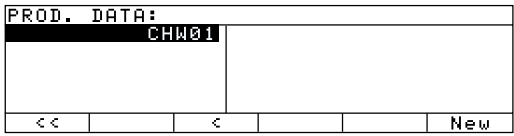
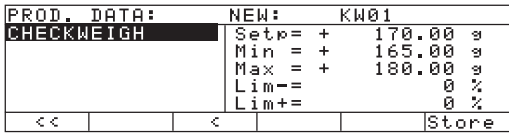
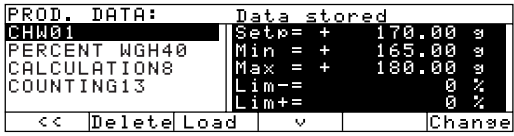
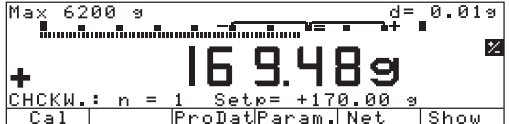
Step	Key (or instruction)	Display/Output
1. If necessary: turn on the balance and enter the settings given above		
2. In the Checkweighing application, toggle to the input mode for target, minimum and maximum values	Param. soft key	
3. Enter target: 170 g; minimum: 165 g; maximum: 180 g	see the Practical Example for Checkweighing, steps 5 through 9	
4. Toggle to display of product data (existing data records are displayed; in this example, 3 data records have been stored)	ProDat soft key	
5. Enter a name for the new data record (here: CHW01)	 ABCDEF soft key, C soft key GHIJKL soft key, H soft key STUVWX soft key, W soft key  	
6. Store current Checkweighing parameters as a data record	New soft key	
7. Confirm	Store soft key	
8. Exit data record display	<< soft key	

SQmin Function

Purpose

To display the allowable minimum sample quantity "SQmin" in accordance with the United States Pharmacopeia (USP). According to USP guidelines, the uncertainty of measurement may not exceed 0.1 % of the sample quantity when substances are weighed with the highest degree of accuracy for volume determination. This additional function ensures that weight results lie within defined tolerance limits corresponding to the requirements of your quality assurance system.

Features

- The service technician will determine the required minimum sample quantity based on your quality assurance requirements at the location where the balance is set up. Afterwards, he will store this value in the balance. This setting cannot be changed by the user. Once he has finished programming the balance, the service technician will prepare a "Test in Accordance with the USP" certificate, on which he will record the measurements and the minimum sample quantity for the balance. If you use the SQmin function, you can be sure that the weight results will correspond to the specifications on the certificate and, therefore, USP guidelines.
- Displaying the minimum sample quantity:
The value is shown in the next line for 4 seconds after the "SQmin" soft key is pressed
or
the value is constantly displayed in place of the bar graph.
- This function can be assigned to either the fourth or fifth soft key from the right (F4 or F5). The soft key should then be labeled with **SQmin**.
- If the minimum sample quantity has not been reached:
The **SQmin** soft key will flash inversely. Weights will be marked with an asterisk "*" in the printout.
- Header of GLP-complicant records: The minimum sample quantity entered for "SQmin" can be printed out in addition.
- The SQmin function can be used only when the highest resolution for the basic unit of the balance has been set.

Factory-set parameters

Display: **Text display**



Print in GLP header: **Off**



Preparation

Turn on the balance: press 

> Sartorius logo is displayed

Select Extra function (F4) or Extra function (F5) in the Setup menu: press 

Select **Application parameters**: press the  soft key twice, then press the  soft key once

Select **Extra function (F4)** or **Extra function (F5)**: press the  soft key repeatedly, then press the  soft key

Select **SQmin**.

Confirm **SQmin**.

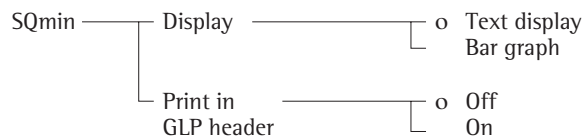

o = Factory setting









See also "Application Parameters (Overview)" in the chapter entitled "Configuration"

Store the settings and exit the Setup menu: press the  soft key.

Example

Determining the weights of samples while monitoring the minimum sample quantity (here: SQmin: 30 mg)

Presettings (different from the factory settings):
 Setup: Application parameters: Additional function (F4): SQmin

Step	Press key(s) (or follow instructions)	Display/Output
1. Switch on the balance if necessary and enter the presettings as shown above		
2. Place the container into which the sample will be filled onto the weighing pan and tare the balance		
3. Weigh a sample (here: the minimum sample quantity has not been reached)	Place the sample on the weighing pan	
4. Print out the weight		*N + 0.02 g
5. Weigh another sample (here: the minimum sample quantity has been exceeded)	Place the sample on the weighing pan	
6. Print out the weight		N + 16.38 g
7. Display the minimum sample quantity for 4 seconds	SQmin soft key	
8. If necessary, weigh further samples		

DKD Uncertainty of Measurement

Purpose

Display of the dynamic uncertainty of measurement in conformance with the specifications listed on the DKD Calibration Certificate.

Features

After Technical Service has prepared the balance:

- A service technician performs on-site DKD calibration of your balance to determine its uncertainty of measurement. On the DKD Calibration Certificate, the measurements and the uncertainty for the initial sample weight are recorded. Then the service technician enters this data in the balance.
- Display of the factor and the exponent entered; activation by accessing the Setup menu: Device information: DKD uncertainty of measurement
- Display of the uncertainty of measurement, for example:
Absolute uncertainty of measurement:
 $U = 0.54 \text{ g}$
Relative uncertainty of measurement:
 $U^* = 0.00045 \%$
Process accuracy:
 $PA = 0.00013 \%$
- Display of up to 2 DKD uncertainty of measurement values:
The first two calculated values that are activated by selecting "Display" in the Setup menu are shown.
- This function can be assigned to a key identified by the fourth or fifth soft key (from the right, F4 or F5).
The soft key is identified by U/PA
- Resolution
The absolute uncertainty of measurement is displayed with a 10 times higher resolution.
The absolute uncertainty of measurement and the process accuracy are displayed with up to 5 decimal places (2 significant decimal places).
- Printout of the addend and the factor of the uncertainty of measurement when the power is turned on:
In the Setup menu, select "Auto print upon initialization: All values."
- Display ----- (for U^* and PG) for:
 - Calculated net values (e.g., counting, weighing in percent, etc.)
 - Values greater than 100%
 - Net value equal to "zero"
- The function for displaying the DKD uncertainty of measurement can be used only when the highest resolution for the basic unit of the balance has been set.

Preparation

Turn on the balance: press ON

- > The Sartorius logo is displayed

In the Setup menu, select "Extra functions (F4)" or "Extra functions (F5)": press Setup

Select the **Application parameters**: press the V soft key 2 times, then the > soft key

Select **Extra function (F4)** or **Extra function (F5)**: press the V soft key repeatedly, then press the > soft key

Select **DKD uncertainty of measurement**

Confirm **DKD uncertainty of measurement**

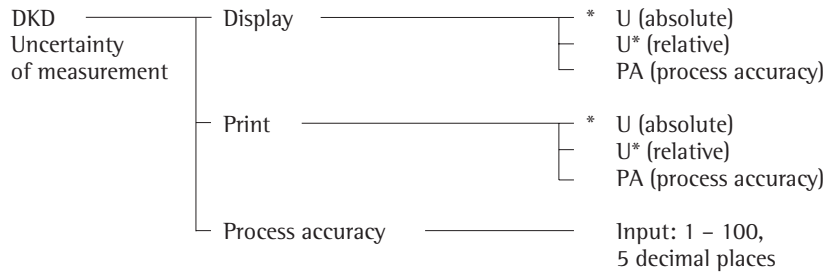

* = An asterisk (*) indicates an activated menu item. You can select up to 3 items.
* = factory setting

See also "Application Parameters (Overview)" in the chapter entitled "Configuration"

Save settings and exit the Setup menu: press the << soft key

Example





Perform a weighing procedure with the “DKD uncertainty of measurement” application

Settings:

Setup: Application parameters: Extra function (F4): DKD uncertainty of measurement: Display: PA (process accuracy)

Setup: Application parameters: Extra function (F4): DKD uncertainty of measurement: Print: PA (process accuracy)

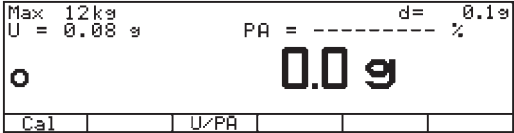
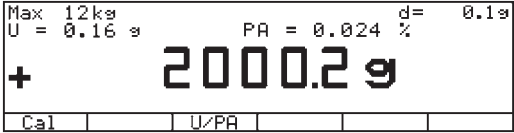
Setup: Application parameters: Extra function (F4): DKD uncertainty of measurement: Display: Input: 3.00000 (factory setting)

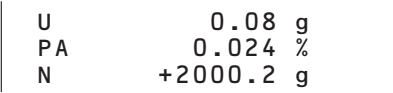
Step	Press key(s) (or follow instructions)	Display/Output
1.	Turn on the balance, if not on, and configure the settings as indicated above	
2.	Place a container for a sample on the balance and tare	 
3.	Measure weight of sample	Add sample to container 
4.	Print weight	 
5.	Weigh next sample (if any)	

Combining Applications

The following table summarizes the possibilities for combination of the application programs described here. Each line stands for one combination. The weighing function is generally available, and does not have to be combined with a calculating function.

Application 1 (basic settings)	Application 2 (checking and control functions)	Application 3 (data records and documenting functions)
Counting	-	Totalizing
Counting	-	Formulation
Counting	-	Statistics
Weighing in percent	-	Totalizing
Weighing in percent	-	Formulation
Weighing in percent	-	Statistics
Animal weighing	-	Totalizing
Animal weighing	-	Statistics
Recalculation	-	Totalizing
Recalculation	-	Statistics
Calculation	-	Totalizing
Calculation	-	Formulation
Calculation	-	Statistics
Density determination	-	Statistics
Density determination	Time-controlled functions	Statistics
Differential weighing	-	-
Air buoyancy correction	-	Totalizing
Air buoyancy correction	-	Statistics
Diameter determination	-	Totalizing
Diameter determination	-	Formulation
Diameter determination	-	Statistics
-	Checkweighing	Totalizing
-	Checkweighing	Formulation
-	Checkweighing	Statistics
Counting	Checkweighing	Totalizing
Counting	Checkweighing	Formulation
Counting	Checkweighing	Statistics
Weighing in percent	Checkweighing	Totalizing
Weighing in percent	Checkweighing	Formulation
Weighing in percent	Checkweighing	Statistics
Recalculation	Checkweighing	Totalizing
Recalculation	Checkweighing	Statistics
Calculation	Checkweighing	Totalizing
Calculation	Checkweighing	Formulation
Calculation	Checkweighing	Statistics
Air buoyancy correction	Checkweighing	Totalizing
Air buoyancy correction	Checkweighing	Statistics
Diameter determination	Checkweighing	Totalizing
Diameter determination	Checkweighing	Formulation
Diameter determination	Checkweighing	Statistics
-	Time-controlled functions	Totalizing
-	Time-controlled functions	Formulation
-	Time-controlled functions	Statistics
Counting	Time-controlled functions	Totalizing
Counting	Time-controlled functions	Formulation
Counting	Time-controlled functions	Statistics
Weighing in percent	Time-controlled functions	Totalizing
Weighing n percent	Time-controlled functions	Formulation
Weighing in percent	Time-controlled functions	Statistics
Animal weighing	Time-controlled functions	Totalizing
Animal weighing	Time-controlled functions	Statistics
Recalculation	Time-controlled functions	Totalizing
Recalculation	Time-controlled functions	Statistics
Calculation	Time-controlled functions	Totalizing
Calculation	Time-controlled functions	Formulation
Calculation	Time-controlled functions	Statistics
Air buoyancy correction	Time-controlled functions	Totalizing
Air buoyancy correction	Time-controlled functions	Statistics
Diameter determination	Time-controlled functions	Totalizing
Diameter determination	Time-controlled functions	Formulation
Diameter determination	Time-controlled functions	Statistics

Examples of Application Combinations

Checkweighing with statistical evaluation

You want to check a piece count, and have the results that lie within the tolerance range statistically evaluated and printed as a ISO/GLP-compliant record.

Settings (changes in the factory settings required for this example):

Setup: Application parameters: Application 1: Counting

Setup: Application parameters: Application 2: Checkweighing



Setup: Application parameters: Application 3: Statistics: Automatic storage: On, first value at stability



Setup: Application parameters: Application 3: Statistics: Source of data for auto storage: Application 2

Setup: Application parameters: Application 3: Statistics: Evaluated value: Calculated

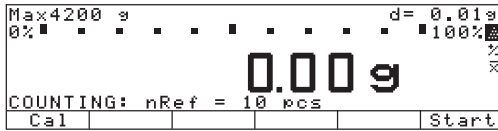
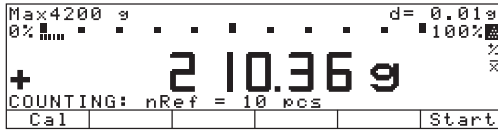
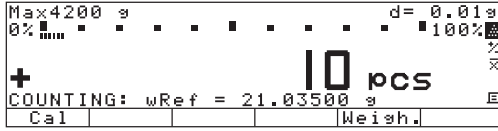
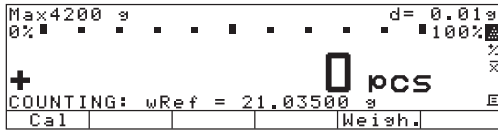
Setup: Application parameters: Application 3: Statistics: Evaluation mode, MR function: Intermediate evaluation, display+print

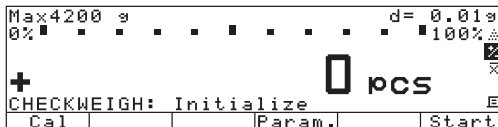
Setup: Application parameters: Printout configuration: ISO/GLP/GMP printout: Always

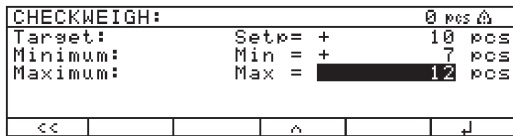
Step	Key (or instruction)	Display/Output
1. If necessary: turn on the balance and enter the settings given above		
2. Place reference sample quantity on the balance	Place parts on the balance	
3. Initialize the balance	Start soft key	 <pre> ----- 18.03.1997 09:41 SARTORIUS Mod. LA4200S Ser.-no. 60419914 Ver.-no. 01-35-18 ID ----- C-ID nRef 10 pcs wRef 21.03500 g n 1 Cnt + 10 pcs </pre>
4. Remove reference sample quantity	Unload the balance	
5. Initialize Checkweighing Toggle to Checkweighing		

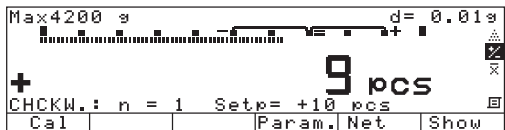
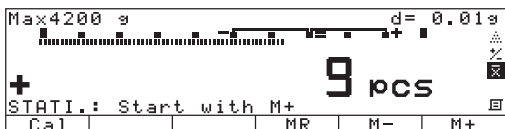
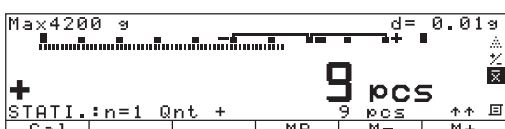
Step	Key (or instruction)	Display/Output																								
6. Enter target, minimum and maximum values (here: target: 10 pcs; minimum: 7 pcs; maximum: 12 pcs)	Param. soft key (1) (0), ↓ soft key (7), ↓ soft key (1) (2)	 <pre> CHECKWEIGH: 0 pcs Target: Setp= + 10 pcs Minimum: Min = + 7 pcs Maximum: Max = 12 pcs </pre>																								
7. Store input	↓ soft key	 <pre> Max4200 g d= 0.01g LL CHCKW.: n = 0 Setp= +10 pcs Cal Param. Net Show </pre> <table border="1" data-bbox="938 707 1422 808"> <tr> <td>Setp</td> <td>+</td> <td>10 pcs</td> </tr> <tr> <td>Min</td> <td>+</td> <td>7 pcs</td> </tr> <tr> <td>Max</td> <td>+</td> <td>12 pcs</td> </tr> </table>	Setp	+	10 pcs	Min	+	7 pcs	Max	+	12 pcs															
Setp	+	10 pcs																								
Min	+	7 pcs																								
Max	+	12 pcs																								
8. Determine first unknown quantity	Place uncounted parts on the balance	 <pre> Max4200 g d= 0.01g + 9 pcs CHCKW.: n = 1 Setp= +10 pcs Cal Param. Net Show </pre>																								
9. Toggle to Statistics	(F1)	 <pre> Max4200 g d= 0.01g + 9 pcs STATI.: Start with M+ Cal MR M- M+ </pre>																								
10. Initialize automatic storage	M+ soft key	 <pre> Max4200 g d= 0.01g + 9 pcs STATI.: n=1 Qnt + Cal MR M- M+ </pre> <table border="1" data-bbox="938 1393 1422 1471"> <tr> <td>n</td> <td>+</td> <td>1</td> </tr> <tr> <td>Qnt</td> <td>+</td> <td>9 pcs</td> </tr> </table>	n	+	1	Qnt	+	9 pcs																		
n	+	1																								
Qnt	+	9 pcs																								
11. Determine further unknown quantities Printout is generated automatically	Place parts to be counted on the balance	<table border="1" data-bbox="938 1527 1422 1807"> <tr> <td>n</td> <td>+</td> <td>4</td> </tr> <tr> <td>Avg.</td> <td>+</td> <td>10.0 pcs</td> </tr> <tr> <td>s</td> <td>+</td> <td>0.8 pcs</td> </tr> <tr> <td>srel</td> <td>+</td> <td>8.00 %</td> </tr> <tr> <td>Total</td> <td>+</td> <td>40 pcs</td> </tr> <tr> <td>Min</td> <td>+</td> <td>9 pcs</td> </tr> <tr> <td>Max</td> <td>+</td> <td>11 pcs</td> </tr> <tr> <td>Diff</td> <td>+</td> <td>2 pcs</td> </tr> </table>	n	+	4	Avg.	+	10.0 pcs	s	+	0.8 pcs	srel	+	8.00 %	Total	+	40 pcs	Min	+	9 pcs	Max	+	11 pcs	Diff	+	2 pcs
n	+	4																								
Avg.	+	10.0 pcs																								
s	+	0.8 pcs																								
srel	+	8.00 %																								
Total	+	40 pcs																								
Min	+	9 pcs																								
Max	+	11 pcs																								
Diff	+	2 pcs																								
12. End weighing series Statistics are evaluated Final GLP printout is generated	(CF)																									
13. Delete initialization of the last application	(CF)	<pre> ----- 18.03.1997 10:26 Name: ----- </pre>																								

Data Output Functions

There are 3 options for data output:

- Output to the display and control unit
- Output to a printer (generate a printout)
- Output to a peripheral device (e.g., computer) via the interface port

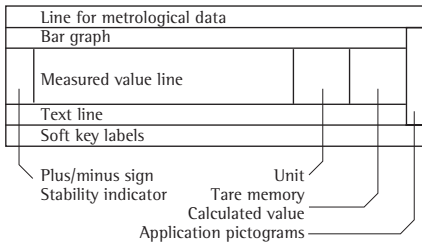

Output to the Display and Control Unit

The display is divided into 9 sections. Information about the balance, the application being used and the sample weighed is output in the following sections:

- Line for metrological data
- Bar graph
- Plus/minus sign, stability symbol display
- Measured value line
- Weight unit display
- Data in tare memory; calculated value
- Application symbol display
- Text line
- Soft key labels

Line for Metrological Data (on balances verified for legal metrology)

This line shows:

Max 4200 g
Min 0.5 g
e = 0.1 g
d = 0.01 g

- Maximum balance capacity (e.g., 4,200 g)
- Minimum balance capacity; the weight must not go below this limit when the balance is used in legal metrology
- Verification interval of the balance; irrelevant if the balance is not used in legal metrology (e.g., 0.1 g)
- Readability: Indicates the actual scale interval (display increment of the balance) (e.g., 0.01 g)

Bar Graph (overview display)

In the bar graph, weighing results are displayed either





- as a percentage of the maximum balance capacity, or
- in relation to a target value, with tolerance limits indicated.

You can turn off (blank) the bar graph display (Setup: Device: Display: Digit size: 13 mm + text display or 13 mm)

Plus/Minus Sign, Stability Symbol

This section shows:

-  - "Busy" symbol
-  - Plus or minus sign
-  - Zero symbol (indicating the scale has been zeroed)

125.03
 35
 =W* 18.3*0.9

g
 PCS

▲
 NET1 NET2

U1 ▲ ✕ ⊗ ⊖

✕ ⊖

Σ ⊕ ⊗

⊗

⊖

COUNTING: nRef = 10 pcs

Ref.wt. too light

Cal PT1/T1 S ID M+

<< < ^ v > ↓

Measured Value Line

This line shows:

- The current weight value (bordered values are invalid in legal metrology)
- Calculated values (e.g., piece count)
- User input (e.g., lot number, equation)

Weight Unit Display

This section shows:

- The current weight unit (e.g., kg)
- Designation of other values (e.g., "pcs")

Tare Memory, Calculated Value

This section shows:

- Indication that value is calculated (not valid in legal metrology)
- Indication that the tare memory contains application data

Application Symbols

This column shows:

- Symbol for Application 1 (toggling between weight units, counting, weighing in percent, animal weighing, calculation)
- Symbol for Application 2 (checkweighing, time)
- Symbol for Application 3 (totalizing, formulation, statistics)
- Symbol for current print job
- Symbol for ISO/GLP printout

Text Line

This line contains:

- Explanatory text about the application program (e.g., about "Counting")
- Explanation of error codes

Soft Key Labels

This line shows

- Texts (abbreviations) to indicate the function assigned to each key
- Symbol for selecting and confirming parameter settings (see also "Operating Design")

Balance Information

In the Setup menu, you can select **Setup: Info: Device information** for a display of balance information. The display includes:

- Software version number
- Balance version number
- Balance model
- Balance serial number
- Date: next maintenance
- Service phone

SETUP	INFO
Version no.:	01-35-10
Bal. ver. no.:	00-20-13
Model:	LA5200P
Serial no.:	70906913
<<	

Printouts

Purpose

This function enables you to print out weights, other measured values and IDs. You can format the printout to meet different requirements.

Features

Line format: you can configure a data ID code with up to 6 characters at the beginning of each of the values to be printed

Weight ID:

You can configure an extra line for identification of each weighed or calculated value using the code **S ID**

Print application parameters:

You can generate a printout of the values configured for initialization of an application before printing the measured results

ISO/GLP-compliant printout:

You can print out parameters relating to the weighing conditions

Print animal weights:

Application-defined, automatic printout of animal weights or of animal weights plus calculated weights after averaging

Optimizing interfaces:

- Use the highest possible baud rate
- Turn off interfaces that are not in use
- Optimize the amount of data to be transferred

Configuring Printout Formats

For a number of application programs, you need to set initialization values. All values upon initialization or only the main values can be automatically printed as soon as you have configured this in the Setup menu: **Auto print upon initialization**

Weights and calculated values can be printed as numeric values either with a preceding data ID code (numeric value with 22 characters) or without one (numeric value only 16 characters). See also the section on **Line format** in the chapter entitled "Data Output Functions".

You can generate an ISO/GLP print-out always or only for calibration/adjustment or turn off this option. See also page 116.

Generating an ISO/GLP Printout

In the Setup menu, you have a choice of three settings:

- No ISO/GLP printout generated (**Off**)
- ISO/GLP printout generated only for calibration/adjustment (**Only for calibration/adjustment**)
- Every printout is an ISO/GLP-compliant report (**Always on**)

Auto print checkweighing results: automatic printout of a weight when it lies within the preset limits at stability

Auto print with time-controlled functions: automatic printout of weights after a preset time has elapsed or at a defined time
Printout of intermediate or final evaluation from the application 3 memory (totalizing, formulation and statistics); generate by pressing the **MR** soft key

Generating Printouts Acceptable for Legal Metrology:

You can configure the Setup menu of the balance to generate data records that are acceptable for legal metrology on a Sartorius printer:

- YDP02
- YDP03
- YDP011S
- YDP011S Label
- YDP021S
- YDP021S Label
- YDP041S
- YDP041S Label

ISO/GLP-compliant Printout/Record

You can have the parameters pertaining to weighing conditions printed before (GLP header) and after (GLP footer) the values from the weighing series. These parameters include:

- Date
- Time at the beginning of a weighing series
- Balance manufacturer
- Balance model
- Model serial number
- Software version
- Lot number (weighing series no.)
- Time at the conclusion of the weighing series
- Field for operator signature

Operating the Balance with an ISO/GLP-capable Documentation Device (Printer)

ISO/GLP-compliant documentation requires a computer with special software. Contact Sartorius for a detailed description for creating this software.

Setting:

Setup: Printout: ISO/GLP/GMP printout: Always on

The record is output to a Sartorius YDP03-OCE Data Printer or a computer.

End GLP printout:

- Press **CF**
- End GLP printout while application is active:

This requires the following settings:
Setup: Device: Keys: CF function in application: Clear only selected applications

- Press **CF**
- > Text line: CF selected: clear application

- Press the **GLP** soft key

```
-----  
17.01.1997      16:12  
      SARTORIUS  
Mod.           LA4200S  
Ser. no.       60419914  
Ver. no.       01-35-18  
ID            12345678901234  
-----  
L ID 12345678901234  
nRef          10 pcs  
wRef          1.35274 g  
Qnt +         235 pcs  
Qnt +         4721 pcs  
S ID 12345678901234  
Qnt +          567 pcs  
-----  
17.01.1997      16:13  
Name :
```

```
-----  
17.01.1997      16:24  
      SARTORIUS  
Mod.           LA4200S  
Ser. no.       60419914  
Ver. no.       01-35-18  
ID            12345678901234  
-----  
L ID 12345678901234  
Internal calibration  
Start: manual  
Diff. +        0.006 g  
Internal calibration  
              completed  
Diff. +        0.000 g  
-----  
17.01.1997      16:25  
Name :
```

Dotted line
Date/time
Balance manufacturer
Balance model
Balance serial number
Software vers. (display and control unit)
Balance ID no.
Dotted line
Weighing series no.
Application initialization value
Application initialization value
Counting result
Counting result
ID for counting result
Counting result
Dotted line
Date/time
Field for operator signature
Blank line
Dotted line

Record of Internal
Calibration/Adjustment:

Dotted line
Date/time
Balance manufacturer
Balance model
Balance serial number
Software vers. (display and control unit)
Balance ID no.
Dotted line
Weighing series no.
Calibration adjustment mode
Beginning mode for calibration/adjustment
Difference after calibration/adjustment
Confirmation of completed
calibration/adjustment routine
Difference between current and target
values after calibration
Dotted line
Date/time
Field for operator signature
Blank line
Dotted line

Interface Description

Purpose

Your LA Reference balance comes equipped with an interface port for connection to a computer or other peripheral devices.

You can use an on-line computer to change, start and/or monitor the functions of the balance and the application programs. The interface port also has four control lines for the over/under checkweighing program. You can also connect a hand switch or foot switch.

⚠ Warning When Using Pre-wired RS-232 Connecting Cables!

RS-232 cables purchased from other manufacturers often have incorrect pin assignments for use with Sartorius balances. Be sure to check the pin assignment against the chart below before connecting the cable, and disconnect any lines marked "Internally Connected" (e.g., pin 6). Failure to do so may damage or even completely ruin your balance and/or peripheral device.

Available Features

Type of interface:	Serial interface
Operating mode:	Full duplex
Standard:	RS-232
Transmission rates:	150; 300; 600; 1,200; 2,400; 4,800; 9,600; 19,200 baud
Parity:	Space, odd, even
Character format:	1 start bit, 7-/8-bit ASCII, parity, 1 or 2 stop bits
Handshake:	2-wire interface: via software (XON/XOFF); 4-wire interface: via hardware handshake lines (CTS/DTR)
Operating mode:	SBI, xBPI*
Network address**:	0, 1, 2, ..., 30, 31
Data output format of the balance:	16 or 22 characters

* xBPI operating mode: 9,600 baud, 8 bits, odd parity, 1 stop bit

** Network address is only valid in the xBPI mode

Factory Settings:

Transmission rate:	1,200 baud
Parity:	Odd
Stop bits:	1 stop bit
Handshake:	Hardware 1 character after CTS
Operating mode:	SBI
Network address:	0
Print manually/automatically:	Manual after stability
Stop automatic printing:	Not possible
Automatic printout, time-dependent:	After 1 display update
Tare after indiv. printout:	Off
Application initialization values:	Off
Line format:	For other applications/GLP (22 characters)

Preparation

- See page 122 for the pin assignment chart

Line Format (Data Output Format)

You can output the values displayed in the measured value line and the weight unit with or without a data ID code

Example: Without data ID code

+ 253 pcs

Example: With data ID code

Qnt + 253 pcs

Configure this parameter in the Setup menu (Setup: Printout: Line format).

The output with data ID code has 16 characters; without data ID code, 22 characters.

Output Format With 16 Characters

Display segments that are not activated are output as spaces. Characters without a decimal point are output without a decimal point.

The following characters can be output, depending on the characters displayed on the balance:

Normal Operation

Position	1	2	3	4	5	6	7	8	9	10	11	12	13	14	15	16
	+	*	D	D	D	D	D	D	D	D	*	U	U	U	CR	LF
or	-		*	*	*		
or	*	*	*	*	*	*	*	*	*	*						

*: Space
 D: Digit or letter
 U: Unit symbol
 CR: Carriage return
 LF: Line feed

Special Codes

Position	1	2	3	4	5	6	7	8	9	10	11	12	13	14	15	16
	*	*	*	*	*	*	-	-	*	*	*	*	*	*	CR	LF
or							H	H								
or							L	L								
or							C									

*: Space
 --: Weight
 H: Overload
 H H: Overload in checkweighing
 L: Underload
 L L: Underload in checkweighing
 C: Calibration/adjustment

Error Codes

Position	1	2	3	4	5	6	7	8	9	10	11	12	13	14	15	16
	*	*	*	E	r	r	*	*/#	#	#	*	*	*	*	CR	LF

*: Space
 # # #: Error code number

Data output example: + 1255.7 g

Position	1	2	3	4	5	6	7	8	9	10	11	12	13	14	15	16
	+	*	*	*	1	2	5	5	.	7	*	g	*	*	CR	LF

- Position 1: Plus or minus sign or space
- Position 2: Space
- Position 3–10: Weight with a decimal point; leading zeros = space
- Position 11: Space
- Position 12–14: Unit symbol or space
- Position 15: Carriage return
- Position 16: Line feed

Data Output With ID Code

When data with an ID code is output, the ID code consisting of 6 characters precedes the data with the 16-character format. These 6 characters identify the subsequent value.

1	2	3	4	5	6	7	8	9	10	11	12	13	14	15	16	17	18	19	20	21	22
I	I	I	I	I	I	+	*	D	D	D	D	D	D	D	*	U	U	U	CR	LF	
*	*	*	*	*	*	-	*	*	*			
						*	*	*	*	*	*	*	*	*	*						

- I: ID code character¹⁾
- *: Space
- D: Digit or letter
- U: Unit symbol¹⁾ see “Toggling between Weight Units”
- CR: Carriage return
- LF: Line feed

¹⁾ depends on balance type; e.g., not all units and characters are available on balances verified for use in legal metrology

Special Codes

1	2	3	4	5	6	7	8	9	10	11	12	13	14	15	16	17	18	19	20	21	22
S	t	a	t	*	*	*	*	*	*	*	*	-	-	*	*	*	*	*	*	CR	LF
												H	H								
												L	L								
												C									

- *: Space
- -: Weight
- H: Overload
- H H: Overload in checkweighing
- L: Underload
- L L: Underload in checkweighing
- C: Calibration/adjustment

Error Codes

1	2	3	4	5	6	7	8	9	10	11	12	13	14	15	16	17	18	19	20	21	22
S	t	a	t	*	*	*	*	*	E	r	r	*	#	#	#	*	*	*	*	CR	LF

- *: Space
- ###: Error code number

ID code characters 1¹⁾

Stat	Status
ID	Identifier
L ID	Weighing series no.
W ID	Weight set number
Nom.	Exact calibration weight
S ID	Sample ID
NUM	Numeric input
T1	Application tare memory 1
N	Net weight (T1 = 0)
N1	Net weight (T1# 0)
Qnt	Quantity
Prc	Percentage
nRef	Reference sample quantity
pRef	Reference percentage
wRef	Average piece weight
Wxx%	Reference percentage weight
mDef	Target value for animal weighing
Mul	Multiplication factor for animal weighing
x-Net	Result in animal weighing
x-Res	Calculated result in animal weighing
Res	Result using equation (Calculation)
Setp	Target value for checkweighing
Min	Lower limit for checkweighing
Max	Upper limit for checkweighing
Time	Time that a value was stored
Compxx	No. of components in formulation
Tot.c.p	Total weight in formulation
n	Transaction counter
Total	Sum of all values
Avg	Average in statistics
s	Standard deviation
srel	Variation coefficient
Diff	Difference between maximum and minimum

Data Input Format

You can connect a computer to your balance to send commands via the balance interface port to control balance functions and applications.

The commands sent are control commands and may have different formats; e.g., control commands can have up to 26 characters. Each character must be transmitted according to the settings configured in the Setup menu for data transmission.

Format for Control Commands

Format 1:	Esc	!	CR	LF				
Format 2:	Esc	!	#	_	CR	LF		
Format 3:	Esc	!	#	èt	(max. 20 èt)	èt	_	CR LF
Format 4:	Esc	!		èt	(max. 20 èt)	èt	_	CR LF

Esc:	Escape	_:	Underline (ASCII: 95)
!:	Command character	CR:	Carriage RETURN (optional)
#:	Number	LF:	Line FEED (optional)
èt:	Number or letter	max:	depends on command character: i.e. parameter: once the max. length is reached, input received is cut off, rather than discarded as with keyboard input

Format 1

!	Meaning
I	Weighing mode 1
L	Weighing mode 2
M	Weighing mode 3
N	Weighing mode 4
O	Block keys
P	Print
R	Unblock keys
S	Restart
T	Tare and zero
Z	Internal calibration/adjustment**
Q	Acoustic signal

Format 2

!#	Meaning
f3	Zero
f4	Tare (without zeroing)
kF1	Soft key 1* Function depends
...	on setting in
kF6	Soft key 6* application program
kF7	Function key
kF8	Function key
s3	Function key 
x0	Perform internal calibration**
x1	Print balance model
x2	Print weighing platform serial number
x3	Print weighing platform software version
x4	Print display and control unit software version
x5	Print operator ID
x6	Print weight set ("inventory") number
x7	Print batch number

Format 3 (not allowed in the Setup menu)

!#	Meaning
z5	Input (GLP) balance ID no. (20 characters max.)
z6	Input weight set ("inventory") number (14 characters max.)
z7	Input weighing series no. (20 characters max.)

Format 4

!	Meaning
t	Text input in display

* numbered from right to left

** Internal calibration weight necessary

Synchronization

During data communication between the balance and an on-line device (computer), messages consisting of ASCII characters are transmitted via the interface. For error-free data communication, the parameters for baud rate, parity, handshake mode and character format must be the same for both units.

You can set these parameters in the Setup menu so that they match those of the on-line device. You can also define parameters in the balance to make data output dependent on various conditions. The conditions that can be configured are described under each of the application program descriptions.

If you do not plug a peripheral device into the balance interface port, this will not generate an error message.

Handshake

The balance interface (Sartorius Balance Interface = SBI) has transmit and receive buffers. You can define the handshake parameter in the Setup menu:

- Hardware handshake (CTS/DTR)
- Software handshake (XON, XOFF)

Hardware Handshake

With a 4-wire interface, 1 more character can be transmitted after CTS (Clear to Send).

Software Handshake

The software handshake is controlled via XON and XOFF. When a device is switched on, XON must be transmitted to enable any connected device to communicate.

When the software handshake is configured in the Setup menu, the hardware handshake becomes active after the software handshake.

The data transmission sequence is as follows:

```
Balance      --- byte ---> Computer
(transmitting --- byte ---> (receiving
device)      --- byte --->  device)
            --- byte --->
            <--- XOFF ---
            --- byte --->
            --- byte --->
            ...
            (Pause)
            ...
            <--- XON ---
            --- byte --->
            --- byte --->
            --- byte --->
            --- byte --->
```

Transmitting Device:

Once XOFF has been received, it prevents further transmission of characters.

When XON is received, it re-enables the transmitting device to send data.

Receiving Device:

XOFF is transmitted after the 26th character has been stored. To prevent too many control commands from being received at one time, XON is not transmitted until the buffer is almost empty.

Activating Data Output

You can define the data output parameter so that output is activated either when a print command is received or automatically and synchronous with the balance display or at defined intervals (see application program descriptions and auto-print setting).

Data Output by Print Command

The print command can be transmitted by pressing  or by a software command (Esc P).

Automatic Data Output

In the "auto print" operating mode, data is output to the interface port without a print command. You can choose to have data output automatically at defined print intervals with or without the stability parameter. Whichever parameter you select, the data will be output as the readouts appear on the balance display. The display update frequency depends on both the model of the balance and the current operating status.

If you select the auto print setting, data will be transmitted immediately the moment you turn on the balance. In the Setup menu you can configure whether this automatic output can be stopped and started by pressing .

Pin Assignment Chart

Female Interface Connector:

25-position D-Submini, DB25S, with screw lock hardware for cable gland

Male Connector Used:

(please use connectors with the same specifications):

25-pin D-Submini, DB25S, with integrated shielded cable clamp assembly (Amp type 826 985-1C) and fastening screws (Amp type 164 868-1)

Pin Assignment Chart:

- Pin 1: Signal Ground
- Pin 2: Data Output (TxD)
- Pin 3: Data Input (Rx/D)
- Pin 4: Signal GND
- Pin 5: Clear to Send (CTS)
- Pin 6: Internally Connected
- Pin 7: Internal Ground (GND)
- Pin 8: Internal Ground (GND)
- Pin 9: Reset _ In**)
- Pin 10: - 12 V Output
- Pin 11: + 12 V Output
- Pin 12: Reset _ Out***)
- Pin 13: + 5 V Output
- Pin 14: Internal Ground (GND)
- Pin 15: _____
- Pin 16: _____
- Pin 17: _____
- Pin 18: _____
- Pin 19: _____
- Pin 20: Data Terminal Ready (DTR)
- Pin 21: Ext. Supply Voltage Ground (GND)
- Pin 22: Not Connected
- Pin 23: Not Connected
- Pin 24: Ext. Supply Voltage Input + 15 ... 25 V
- Pin 25: +5 V Output

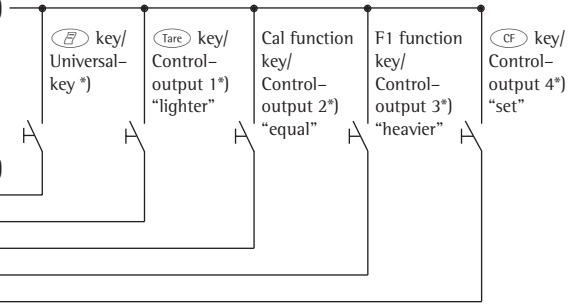

- *) = See "Additional Functions" for information on changing pin assignments
- **) = Hardware restart
- ***) = Restart of peripheral devices

Cabling Diagram

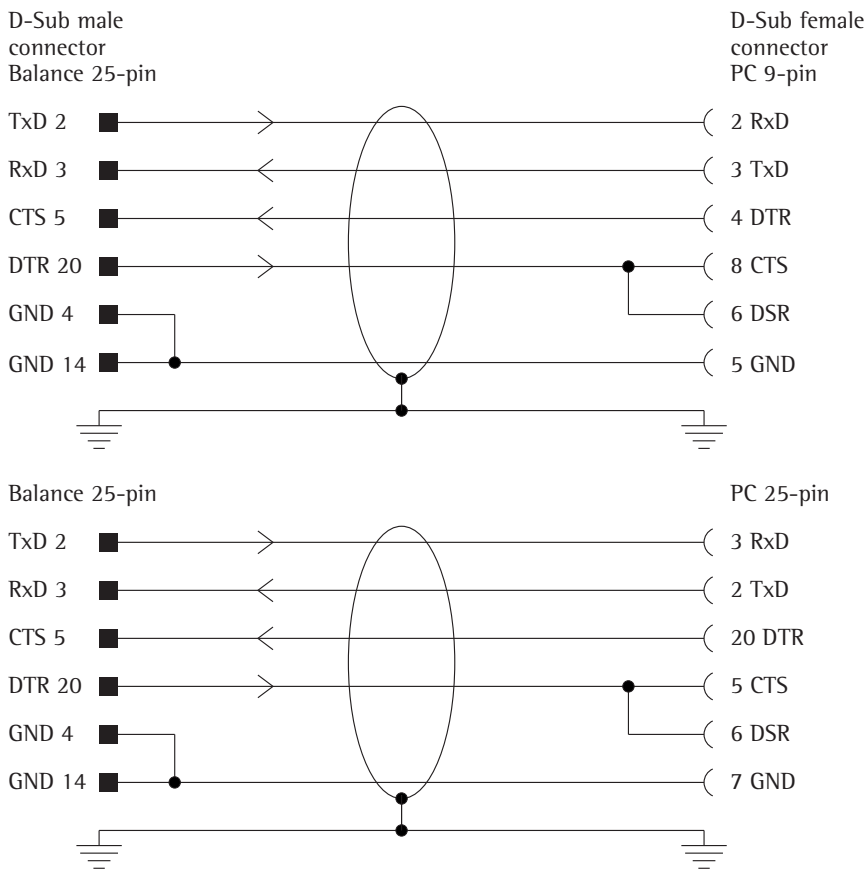
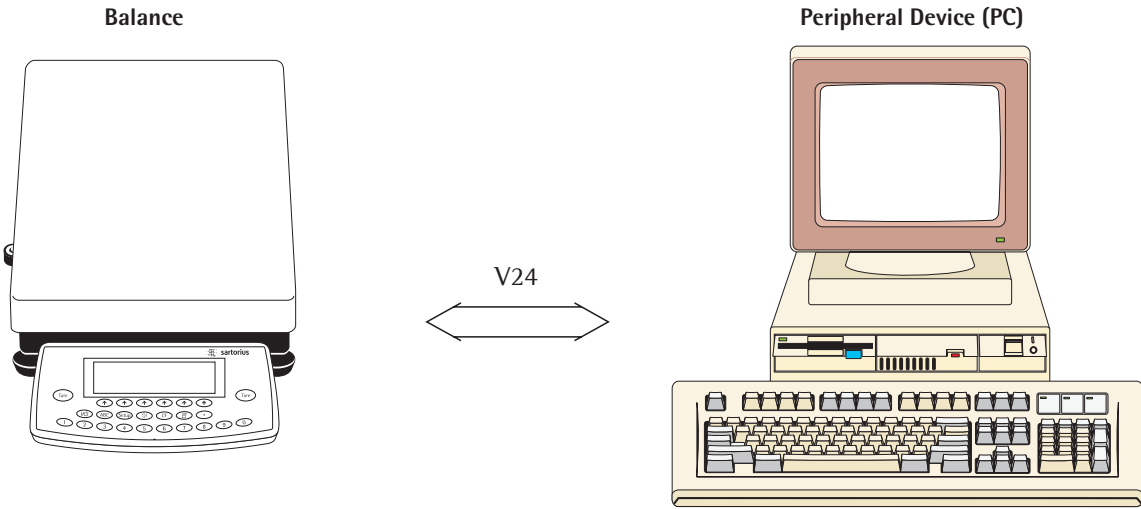

- Diagram for interfacing a computer or different peripheral devices to the balance using the RS-232/V24 standard and cables up to 15 m (50 ft.) long



Type of cable: AWG 24 specification

Error Codes and Messages

Error codes and messages are displayed in the main display or text line for 2 seconds. The program then returns automatically to the previous status.

Display	Cause	Solution
No segments appear on the display	No AC power is available The AC adapter is not plugged in Automatic shutoff configured in Setup (code B 7 i)	Check the AC power supply Plug in the AC adapter Press  to switch on the balance or select "no automatic shutoff" in Setup
H	The load exceeds the balance capacity	Unload the balance capacity
L or Err 54	The weighing pan is not in place	Place the weighing pan on the balance
Err 01 > Display range	Data output not compatible with output format	Change the configuration in the Setup menu
Err 02 Cal. n. possible	Calibration/adjustment condition not met, e.g., – The balance was not tared – The balance is loaded	Calibrate only when zero is displayed Press  to tare Unload the balance
Err 03 Cal./adj. interrupt	Calibration/adjustment could not be completed within a certain time	Allow the balance to warm up again and repeat the adjustment process
Err 05	Built-in calibration weight cannot be retracted	Contact your local Sartorius Service Center
Err 06 Int. wt. defective	Built-in calibration weight is defective	Contact your local Sartorius Service Center
Err 07 Function blocked	Function not allowed in balances verified for use in legal metrology	Contact your local Sartorius Service Center for information on having the settings changed
Err 08* <> zero range	The load on the balance is too heavy to zero the readout	Check whether the "power-on zero range" is set
Err 09* < 0 not allowed	Taring is not possible when the gross weight is \leq zero	Zero the balance
Err 10 Tare fct. blocked	Tare key and 2nd tare memory are blocked when there is data in the tare memory for the formulation application Differential weighing: The tare key is blocked when a tare weight is stored for a specific sample	Press  to clear the formulation application; the tare key and 2nd tare memory are then accessible Differential weighing: Unload the balance or change to a different sample
Err 11 Tare2 blocked	Tare memory not allowed – Cannot load the sample tare weight – Total weight in the tare memory exceeds the capacity of the balance – Tare value exceeds the fine range of the verified balance	Check the tare value entered
Err 12 Tare2 > Max.	Tare memory greater than weighing range or range limits	Check sample/container
Err 17 Adj.-wt. > Max.	Internal adjustment is not possible because preload is too heavy	Reduce the preload or change the configuration
Err 30 Print fct. blocked	Interface port for printer output is blocked	Contact your local Sartorius Service Center

* = occurs only via the SBI interface (ESC f3_/f4_)

Display/Problem	Cause	Solution
Err 31 Print fct. blocked	Interface handshake interrupted (XOFF, CTS)	Transmit XON, then CTS
Ref.wt. too light	Error in storing reference weight (with the counting or weighing-in-percent application)	Weight too light or there is no sample on the balance
Cannot update	Reference updating not possible (with the counting application)	See "Counting" in "Operation" for reference updating criteria
Not a number xxxxx Too low xxxxx Too high	Input wrong (with any application program), e.g., alphabetic input not allowed	Follow the instructions for the application programs
Too many char.	Input text too long	Allowable text lengths, incl. decimal point: – S ID, NUM, L ID, ID: max. 20 characters – W ID: max. 14 characters
Wrong line format	Configured printout, printout memory and 16-character format selected	Select the 22-character format
Limits unequal for unit	Unit entered for tolerance limits in check-weighing different from the appl. used	Adjust tolerance limits
Equation too long	Equation exceeds 28 characters in formulation	Limit equation to 28 characters
Err 10x x = 1 : x = 2 : x = 3 : x = 4 :	Key is stuck Key pressed when switching on the balance: ↑ (F1, F2, F5, F6), CF 0, 1, 2, 3, 4, 5, 6, 7, 8, 9 ., /, Tare -right 1, 2, 3, 4, 5, 6, 7, 8, 9, 0, ↑ (F4), ABC, Tare -left Setup key was pressed when turning on the balance, or is stuck	Release key or Contact your local Sartorius Service Center
"Checkerboard" pattern displayed continuously		
Err 320	Operating program memory defective	Contact your local Sartorius Service Center
Err 340	Operating parameter (EEPROM) is wrong RAM lost data Factory settings deleted	Turn the balance off, then back on again. If this error remains displayed, please contact your local Sartorius Service Center
Err 341	Battery needs to be recharged	Leave the balance power on for at least 10 hours
No WP blocked	Weighing platform is defective Function blocked	Contact your local Sartorius Service Center none
The special code  remains displayed	None of the keys has been pressed since the balance was turned on	Press a key
The weight readout changes constantly	Unstable ambient conditions Too much vibration, or the balance is exposed to a draft A foreign object is caught between the pan and the balance housing	Set up the balance in another area Change Setup configurations to adapt the balance to the ambient conditions Remove the foreign object
The weight readout is obviously wrong	The balance has not been calibrated/adjusted The balance was not tared before weighing The balance is not level The dust cover is caught under the weighing pan	Calibrate/adjust the balance Tare before weighing Level the balance See "Replacing the Dust Cover" in the chapter "Care and Maintenance"

Error Code/Message Displayed	Cause	Solution/Remarks
Differential weighing:		
SAMPLE: Confirm delete/omit	"SAMPLE: delete/omit" prompt on display page for samples	Select Yes to delete Select Omit to omit
SAMPLE: Include	"SAMPLE: include" prompt on display page for samples	Select Omit to include a sample already omitted
Cannot store	File manager: – Not possible to save data – No available memory	Delete lot(s)
Cannot load	File manager: – Not possible to load data – Memory capacity limit reached	Delete lot(s)
Only 30 backweighs possible	An attempt was made to save a 31st backweighing operation	None
LOT: already exists	Lot already exists on the display page for LOTS	Choose a different lot ID
No sample	The Sample key was pressed when the display page for lots was shown, but there are no samples in the lot selected	Save sample first
Out of range	On the display page for LOTS or SAMPLES , an alphanumeric lot or sample ID was input and not found	Enter the correct lot or sample ID
Not enough memory space or 999 samples maximum	An attempt was made to save more than 999 samples using the numeric keys and the #S01 key	Use less memory or delete one or more lots
Sample omitted	An attempt was made to save data from an omitted sample	None
Value too small to accept	An attempt was made to save a tare, initial or backweight that is less than one display digit	Place the particular weight on the balance
No choice available	Factor was selected while attempting to activate the display page for results No 2 nd resolution available	Selection not possible Contact your local Sartorius Service Center
CF not possible	Only one sample or certain portions of a sample can be deleted by pressing the CF key. This message indicates that further delete functions are not possible.	Samples can be deleted one at a time on the display page for samples
Calculated statistics	Message output when statistics are being calculated. This process can take several seconds if there are many samples.	Goes out automatically
No statistics available	No valid backweights available in this lot	Goes out automatically
No net initial wts. available	In serial and combined weighing, no initial weights found	Measure initial weights

If any other errors occur, contact your local Sartorius Service Center!

Care and Maintenance

Service

Regular servicing by a Sartorius technician will extend the service life of your balance and ensure its continued weighing accuracy. Sartorius can offer you service contracts, with your choice of regular maintenance intervals ranging from 1 month to 2 years. The optimum maintenance interval depends on the operating conditions at the place of installation and on the individual tolerance requirements.

Repairs

Repair work must be performed by trained service technicians. Any attempt by untrained persons to perform repairs may lead to hazards for the user.

Cleaning

- Unplug the AC adapter from the wall outlet (mains supply). If you have an interface cable connected to the balance port, unplug it from the port.
- Clean the balance using a piece of cloth which has been wet with a mild detergent (soap).
- After cleaning, wipe down the balance with a soft, dry cloth
- ⚠ Make sure that no dust or liquid enters the balance housing.
- ⚠ Do not use any aggressive cleaning agents (solvents or similar agents)

Cleaning Stainless Steel Surfaces

Clean all stainless steel parts regularly. Remove the stainless steel weighing pan and thoroughly clean it separately. Use a damp cloth or sponge to clean any stainless steel parts on the balance. You can use any commercially available household cleaning agent that is suitable for use on stainless steel. Clean stainless steel surfaces by wiping them down. Then rinse the equipment thoroughly, making sure to remove all residues. Afterwards, allow the balance to dry. If desired, you can apply oil to the cleaned surfaces as additional protection.

Solvents are permitted for use only on stainless steel parts.

Replacing the Dust Cover

- > Instructions for replacing a damaged dust cover

For LA Series Balances with a Round Glass Draft Shield

Remove the following parts from the balance:

- Draft shield cover
- Glass draft shield cylinder
- Weighing pan
- Pan support
- Shield disk: turn clockwise and lift off
- Old dust cover

Place the new dust cover on the balance and press down on the front and back along the edges until it is seated firmly

Place the shield disk on the balance and turn it counterclockwise

Follow the above instructions in reverse order when placing the remaining parts back on the balance.

For LA Series Balances with a Rectangular Weighing Pan and a Weighing Capacity ≤ 12 kg

Remove the following parts from the balance:

- Weighing pan
- Pan draft shield (depending on balance model)
- Old dust cover

Place the new dust cover over the balance

Follow the above instructions in reverse order when placing the remaining parts back on the balance.

- ⚠ The dust cover must not touch the weighing pan

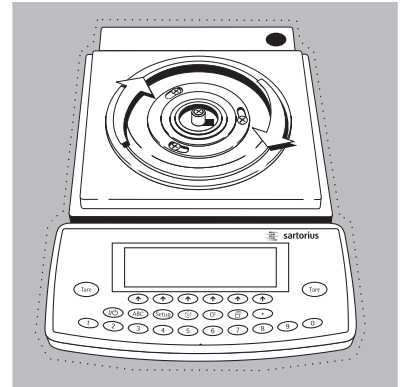

Safety Inspection

If there is any indication that safe operation of the balance is no longer warranted:

- Turn off the power and disconnect the equipment from AC power immediately
- > Lock the equipment in a secure place to ensure that it cannot be used for the time being.

Notify your nearest Sartorius Service Center. Repair work must be performed by trained service technicians.

We recommend having the power supply inspected by a certified electrician at regular intervals, according to the checklist given below:

- Insulating resistance: > 7 megaohms measured with a constant voltage of at least 500 volts at a 500 K-ohm load
- Leakage current: $< 0.05\text{mA}$ measured with a properly calibrated multimeter

Recycling

Information and Instructions on Disposal and Repairs

Packaging that is no longer required must be disposed of at the local waste disposal facility. The packaging is made of environmentally friendly materials that can be used as secondary raw materials.



The equipment, including accessories and batteries, does not belong in your regular household waste.

The EU legislation requires its Member States to collect electrical and electronic equipment and disposed of it separately from other unsorted municipal waste with the aim of recycling it.

In Germany and many other countries, Sartorius AG takes care of the return and legally compliant disposal of its electrical and electronic equipment on its own. These products may not be placed with the household waste or brought to collection centers run by local public disposal operations – not even by small commercial operators.

For disposal in Germany and in the other Member States of the European Economic Area (EEA), please contact our service technicians on location or our Service Center in Goettingen, Germany:

Sartorius AG
Service Center
Weender Landstrasse 94–108
37075 Goettingen, Germany

In countries that are not members of the European Economic Area (EEA) or where no Sartorius affiliates, subsidiaries, dealers or distributors are located, please contact your local authorities or a commercial disposal operator.

Prior to disposal and/or scrapping of the equipment, any batteries should be removed and disposed of in local collection boxes.

Sartorius AG, its affiliates, subsidiaries, dealers and distributors will not take back equipment contaminated with hazardous materials (ABC contamination) – either for repair or disposal. Please refer to the accompanying leaflet/manual or visit our Internet website (www.sartorius.com) for comprehensive information that includes our service addresses to contact if you plan to send your equipment in for repairs or proper disposal.

Overview

General View of the Balances

LA310S (-OCE), LA230S (-OCE), LA230P (-OCE), LA120S (-OCE)

-OCE identifies the precision balances as verified for legal metrology in the EU*

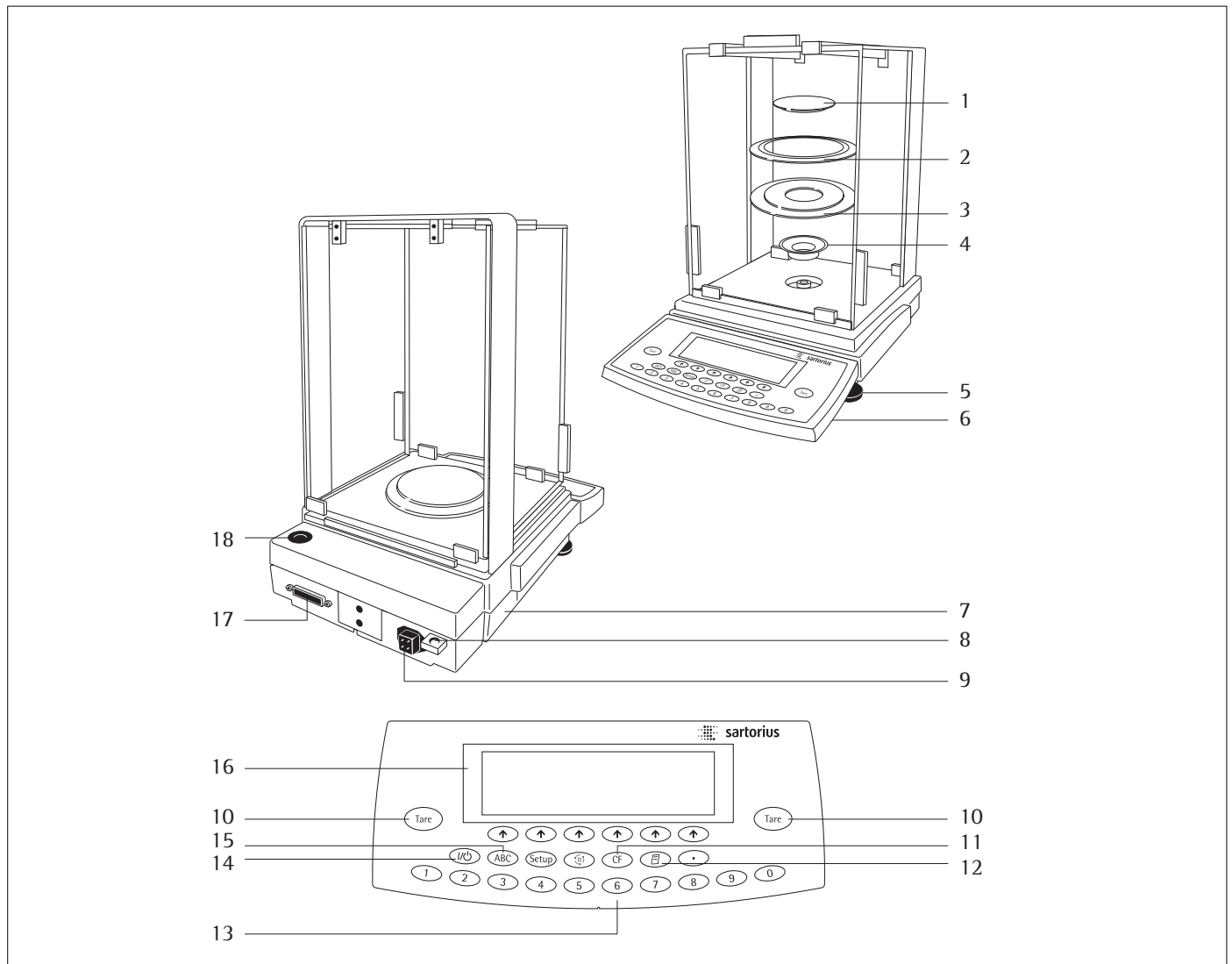

Pos.	Designation	Order No. for replacement	Pos.	Designation	Order No. for replacement
1	Weighing pan	69 LA0006	11	Function keys	
2	Shield disk	69 A20003	12	Print key	
3	Shield plate	69 LA0008	13	Numeric keys	
4	Bushing (pan adapter)	69 LA0007	14	On/off key	
5	Leveling foot	69 B20005	15	Toggle key for alphabetic input	
6	Display and control unit		16	Display	
7	Metrological ID label (only on balances verified for legal metrology)		17	Data interface port	
8	Lug for attaching an anti-theft locking device		18	Level indicator	
9	DC jack		Not shown:		
10	Tare key		In-use dust cover		6960LA01
			Protective caps and plugs (set)		69 B20009

* including the Signatories of the Agreement on the European Economic Area

General Views of the Balances

LA1200S (-OCE), LA620S (-OCE), LA220S (-OCE), LA620P (-OCE), LA5200D, LA3200D, LA2000P

-OCE identifies the precision balances as verified for legal metrology in the EU*

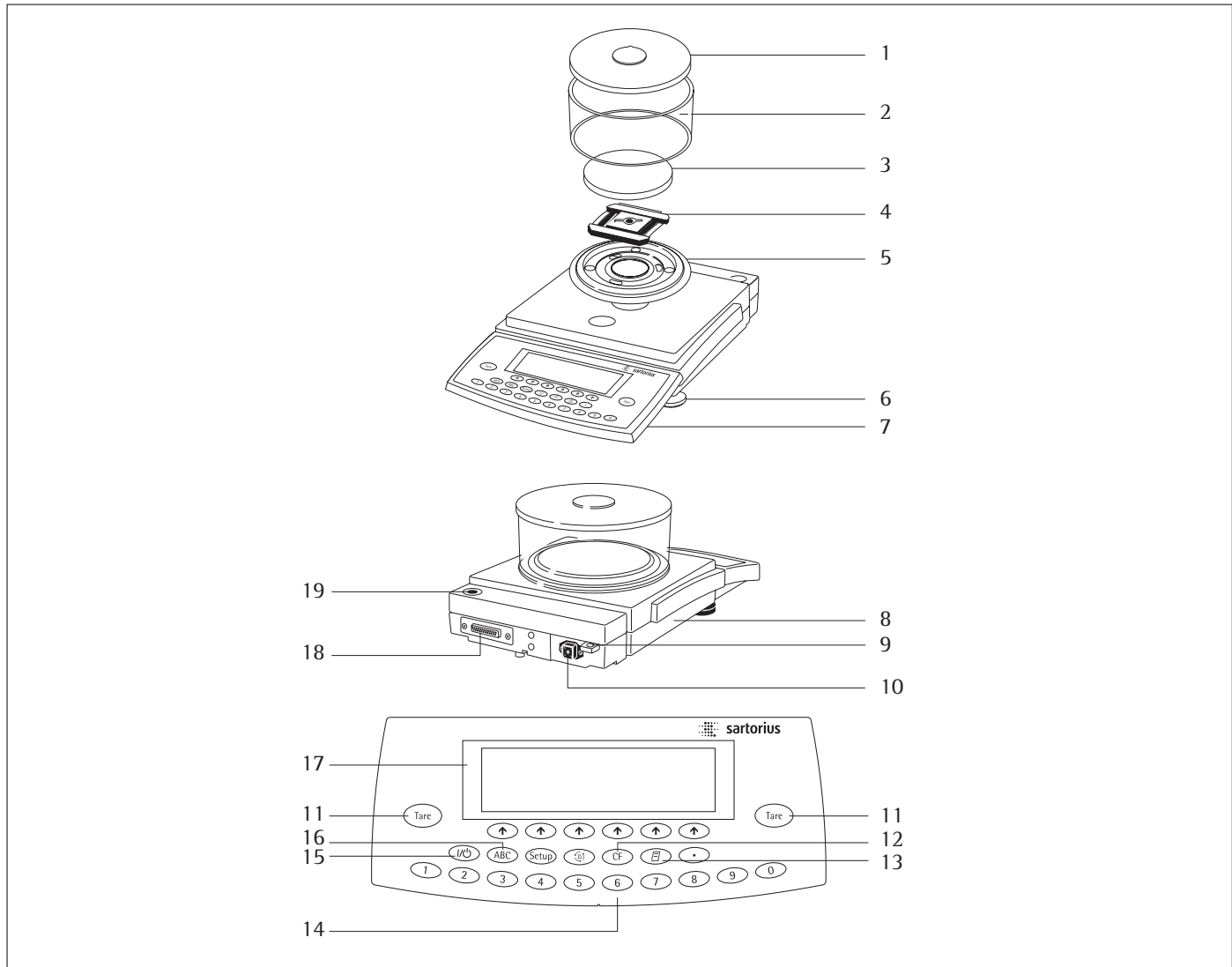

No.	Designation	Order no. for replacement	No.	Designation	Order no. for replacement
1	Draft shield cover	69 LP0002	12	Function keys	
2	Glass draft shield cylinder	69 14290	13	Print key	
3	Weighing pan	69 LP0004	14	Keys for numeric input	
4	Pan support – LA 3200D: – LA 1200S, LA 620, LA 220S:	69 LP0006 69 LP0005	15	On/off key	
5	Shield disk	69 LP0003	16	Toggle key for alphabetic input	
6	Leveling foot	69 B20005	17	Weight display	
7	Display and control unit		18	Interface port	
8	Metrological ID label (only on verified models or models acceptable for legal metrological verification)		19	Level indicator	
9	Lug for attaching an antitheft locking device		Not shown:		
10	DC jack		In-use dust covers:		
11	Tare key		– For weigh cell		6960FB01
			– For control unit		6960LA02
			Protective caps and plugs (set)		69 B20009

* including the Signatories of the Agreement on the European Economic Area

General Views of the Balances

LA8200S (-OCE), LA8200P (-OCE), LA6200S (-OCE), LA4200S (-OCE), LA2200S (-OCE), LA820 (-OCE), LA420, LA2200P (-OCE), LA5200P (-OCE), LA12000S (-OCE), LA6200 (-OCE), LA4200, LA2200 (-OCE), LA12000P (-OCE)
 -OCE identifies the precision balances as verified for legal metrology in the EU*

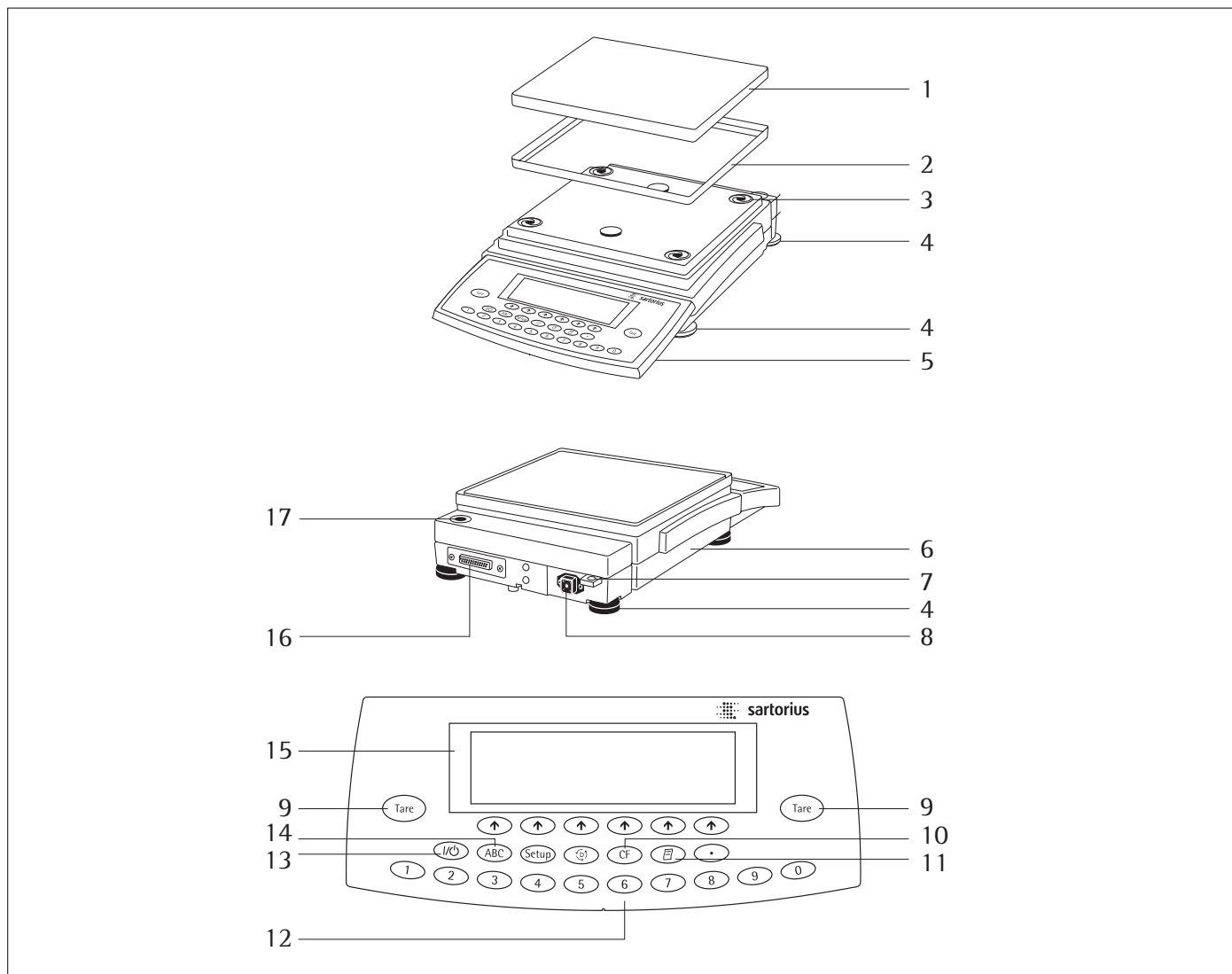

No.	Designation	Order no. for replacement	No.	Designation	Order no. for replacement
1	Weighing pan	69 LP0007	10	Function keys	
2	Pan draft shield (depending on model)	69 LP0008	11	Print key	
3	Shock absorber	69 LP0010	12	Keys for numeric input	
4	Leveling foot	69 B20005	13	On/off key	
5	Display and control unit		14	Toggle key for alphabetic input	
6	Metrological ID label (only on verified models or models acceptable for legal metrological verification)		15	Weight display	
7	Lug for attaching an antitheft locking device		16	Interface port	
8	DC jack		17	Level indicator	
9	Tare key		Not shown:		
			In-use dust covers:		
			- For weigh cell		6960FB02
			- For control unit		6960LA02
			Protective caps and plugs (set)		69 B20009

* including the Signatories of the Agreement on the European Economic Area

General Views of the Balances

LA64001S, LA34001S, LA16001S, LA34001P, LA34000

-OCE identifies the precision balances as verified for legal metrology in the EU*

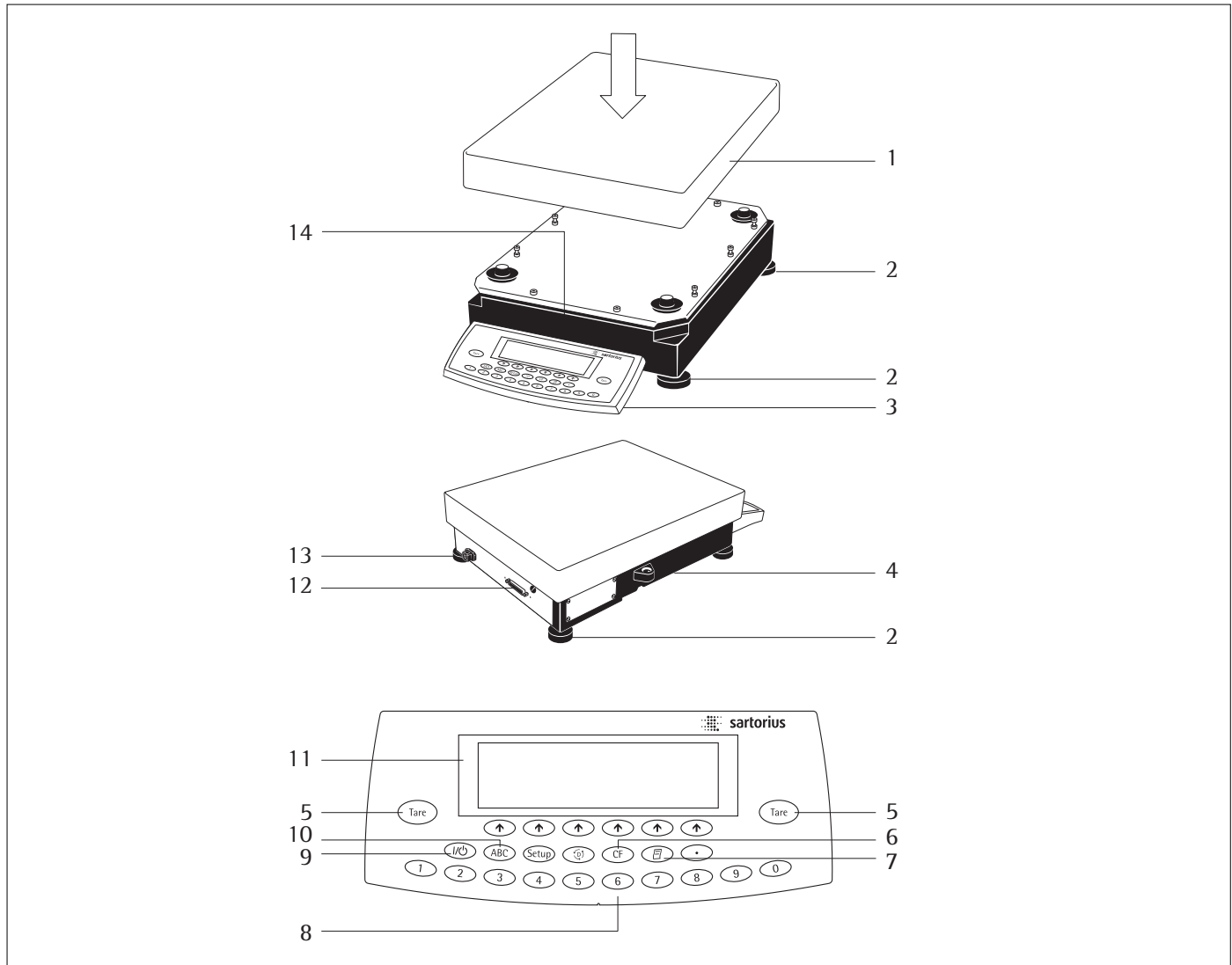

No.	Designation	Order no. for replacement	No.	Designation	Order no. for replacement
1	Weighing pan LA64001S, LA34001S, LA16001S, LA34001P, LA34000:	Available on request	8	Keys for numeric input	
2	Leveling foot	69 LC0093	9	On/off key	
3	Display and control unit		10	Toggle key for alphabetic input	
4	Level indicator		11	Weight display	
5	Tare key		12	Interface port	
6	Function keys		13	DC jack	
7	Print key		14	Metrological ID label (only on verified models or models acceptable for legal metrological verification)	

Not shown:

In-use dust cover for display and control unit

Available
on request

* including the Signatories of the Agreement on the European Economic Area

Specifications

Standard Models

General Specifications

AC power source/power requirements	AC adapter, 230 or 115 V, +15% ... – 20%
Frequency	48 – 60 Hz
Allowable ambient operating temperature	0 ... +40 °C (273 ... 313 K, 32 °F ... 104 °F)
Operating temperature range	+ 10 ... + 30 °C
Adaptation to ambient conditions	By selection of 1 of 4 optimized filter levels
Display update (depends on the filter level selected)	0.1 – 0.4
Power consumption	16 VA: maximum; 9 VA: average
Hours of operation with fully charged YRB 06 Z external battery pack, approx.	14 h
Selectable weight units	Grams, kilograms, carats, pounds, ounces, Troy ounces, Hong Kong taels, Singapore taels, Taiwanese taels, grains, pennyweights, milligrams, parts per pound, Chinese taels, Mommies, Austrian carats, Tola, Baht and Mesghal
Selectable application programs	Mass unit conversion, counting, weighing in percent, animal weighing, recalculation, calculation, density determination, differential weighing, over/under checkweighing, time-controlled functions, totalizing, statistics, 2nd tare memory, IDs, product data memories
Built-in interface	RS-232C Format: 7-bit ASCII, 1 start bit, 1 or 2 stop bits Parity: odd, even or space Transmission rates: 150 to 19,200 baud Handshake: Software or hardware

Specifications of the Individual Models:

Model		LA310S	LA230S	LA230P	LA120S
Readability	mg	0.1	0.1	0.1/0.2/0.5	0.1
Weighing capacity	g	310	230	60/120/230	120
Tare range (subtractive)	g	– 310	– 230	– 230	– 120
Repeatability	≤±mg	0.2	0.1	0.1/0.2/0.5	0.1
Linearity	≤±mg	0.3	0.2	0.2/0.2/0.5	0.2
Sensitivity drift within +10 ... +30 °C	≤±/K	1 · 10 ⁻⁶			
Response time (average)	s	2			
External calibration weight (of at least accuracy class...)	g	200 + 100 (E2)	200 (E2)	200 (E2)	100 (E2)
Other allowable external calibration weights (of at least accuracy class...)	g	200 (E2)	100, 150 (E2)	100, 150 (E2)	50 (E2)
Pan size	mm	∅ 90			
Dimensions (W × D × H)	mm	261 × 381 × 361			
Clearance above pan	mm	259			
Net weight, approx.	kg	8.7			
Dust and water protection rating according to EN 60529*		IP42			

* = specially protected dust-tight and washdown resistant AC adapter; see the section on “Accessories”

Model		LA1200S	LA620S	LA220S	LA620P
Readability	g	0.001	0.001	0.001	0.001/0.002/0.005
Weighing capacity	g	1,200	620	220	120/240/620
Tare range (subtractive)	g	- 1,200	- 620	- 220	- 620
Repeatability (standard deviation)	≤±g	0.001	0.001	0.001	0.001/0.001/0.003
Linearity	≤±g	0.002	0.002	0.002	0.002/0.002/0.005
Sensitivity drift within +10 ... +30 °C	≤±/K	2 · 10 ⁻⁶			
Response time (average)	s	1.5			
External calibration weight (of at least accuracy class...)	g	1,000 (E2)	500 (E2)	200 (E2)	500 (F1)
Other allowable external calibration weights (of at least accuracy class...)	g	-	300, 400, 600 (E2)	100 (E2)	200, 300, 400, 600 (F1)
Pan size	mm	∅ 130			
Dimensions (W × D × H)	mm	261 × 381 × 147			
Net weight, approx.	kg	8.3	6.6	6.6	6.6
Dust and water protection rating according to EN 60529*		IP54			

Model		LA5200D	LA3200D	LA2000P
Readability	g	0.001/0.01	0.001/0.01	0.001/0.01
Weighing capacity	g	1,010/5,200	1,010/3,200	1,010/2,000
Tare range (subtractive)	g	- 5,200	- 3,200	- 2,000
Repeatability	≤±g	0.001/0.01	0.001/0.01	0.001/0.01
Linearity	≤±g	0.002/0.01	0.002/0.01	0.002/0.01
Sensitivity drift within +10 ... +30 °C	≤±/K	2 · 10 ⁻⁶	2 · 10 ⁻⁶	2 · 10 ⁻⁶
Response time (average)	s	2.5	1.5	1.5
External calibration weight (of at least accuracy class...)	g	1,000 (E2)	1,000 (E2)	1,000 (E2)
Other allowable external calibration weights (of at least accuracy class...)	g	2,000, 3,000 (E2)	2,000, 3,000 (E2)	-
Pan size	mm	∅ 130		
Dimensions (W × D × H)	mm	261 × 381 × 147		
Net weight, approx.	kg	8.4		
Dust and water protection rating according to EN 60529*		IP54		

* = specially protected dust-tight and washdown resistant AC adapter; see the section on "Accessories"

Model		LA8200S	LA8200P	LA6200S	LA4200S	LA2200S
Readability	g	0.01	0.01/0.02/0.05	0.01	0.01	0.01
Weighing capacity	g	8,200	2,000/4,000/8,200	6,200	4,200	2,200
Tare range (subtractive)	g	- 8,200	- 8,200	- 6,200	- 4,200	- 2,200
Repeatability (standard deviation)	≤±g	0.01	0.01/0.01/0.03	0.01	0.01	0.01
Linearity	≤±g	0.02	0.02/0.02/0.05	0.02	0.02	0.02
Sensitivity drift within +10 ... +30 °C	≤±/K	2 · 10 ⁻⁶				
Response time (average)	s	2	2	1.5	1.5	1.5
External calibration weight (of at least accuracy class...)	g	5,000 (E2)	5,000 (F1)	5,000 (E2)	2,000 (E2)	2,000 (F1)
Other allowable external calibration weights (of at least accuracy class...)	g	6,000, 7,000, 8,000 (E2)	-	6,000 (E2), 4,000 (E2)	3,000	1,000 (F1)
Pan size	mm	218 × 200				
Dimensions (W × D × H)	mm	261 × 381 × 86				
Net weight, approx.	kg	6.5				
Dust and water protection rating according to EN 60529*		IP54				

Model		LA820	LA420	LA2200P	LA5200P
Readability	g	0.01	0.01	0.01/0.02/0.05	0.01/0.02/0.05/0.1
Weighing capacity	g	820	420	400/800/2,200	1,200/2,400/3,800/5,200
Tare range (subtractive)	g	- 820	- 420	- 2,200	- 5,200
Repeatability (standard deviation)	≤±g	0.01	0.01	0.01/0.01/0.03	0.01/0.02/0.05/0.05
Linearity	≤±g	0.01	0.01	0.02/0.02/0.05	0.02/0.02/0.05/0.1
Sensitivity drift within +10 ... +30 °C	≤±/K	2 · 10 ⁻⁶			
Response time (average)	s	1.5			
External calibration weight (of at least accuracy class...)	g	500 (F2)	200 (F2)	2,000 (F2)	2,000 (F1)
Other allowable external calibration weights (of at least accuracy class...)	g	600, 700, 800 (F2)	300, 400 (F2)	1,000 (F2)	3,000, 4,000, 5,000 (F1)
Pan size	mm	218 × 200			
Dimensions (W × D × H)	mm	261 × 381 × 86			
Net weight, approx.	kg	6.5			
Dust and water protection rating according to EN 60529*		IP54			

* = specially protected dust-tight and washdown resistant AC adapter; see the section on "Accessories"

Model		LA12000S	LA6200	LA4200	LA2200	LA12000P
Readability	g	0.1	0.1	0.1	0.1	0.1/0.2/0.5
Weighing capacity	g	12,000	6,200	4,200	2,200	3,000/6,000/ 12,000
Tare range (subtractive)	g	- 12,000	- 6,200	- 4,200	- 2,200	-12,000
Repeatability (standard deviation)	≤±g	0.05	0.05	0.05	0.05	0.1/0.1/0.3
Linearity	≤±g	0.2	0.1	0.1	0.1	0.1/0.2/0.5
Sensitivity drift within +10 ... +30 °C	≤±/K	4 · 10 ⁻⁶	4 · 10 ⁻⁶	4 · 10 ⁻⁶	2 · 10 ⁻⁶	4 · 10 ⁻⁶
Response time (average)	s	1	1	1	1	1
External calibration weight (of at least accuracy class...)	kg	5 (F1)	5 (F2)	2 (F2)	2 (F2)	5 (F2)
Other allowable external calibration weights (of at least accuracy class...)	kg	6 to 12 (F1)	4, 6 (F2)	3, 4 (F2)	1 (F2)	6, 7, 8, 9, 10, 11, 12 (F2)
Pan size	mm	218 × 200				
Dimensions (W × D × H)	mm	261 × 381 × 86				
Net weight, approx.	kg	6.5				
Dust and water protection rating according to EN 60529*		IP54				

Model		LA64001S	LA34001S	LA16001S	LA34001P	LA34000
Readability	g	0.1	0.1	0.1	0.1/0.2/0.5	1
Weighing capacity	g	64,000	34,000	16,000	8,000/16,000/ 34,000	34,000
Tare range (subtractive)	g	- 64,000	- 34,000	- 16,000	- 34,000	- 34,000
Repeatability	≤±g	0.1	0.1	0.05	0.05/0.05/0.1	0.5
Linearity	≤±g	0.5	0.2	0.2	0.2	0.5
Sensitivity drift within +10 ... +30 °C	≤±/K	3 · 10 ⁻⁶	2 · 10 ⁻⁶	2 · 10 ⁻⁶	2 · 10 ⁻⁶	2 · 10 ⁻⁶
Response time (average)	s	1.5	1.5	1.5	1.5	1
External calibration weight (of at least accuracy class...)	kg	10 (F1)	10 (F1)	10 (F1)	10 (F2)	10 (F2)
Other allowable external calibration weights (of at least accuracy class...)	kg	5, 20, 25, 30 (F1)	15, 20, 25, 30 (F1)	11, 12, 13, 14, 15, 16 (F1)	15, 20, 25, 30 (F2)	15, 20, 25, 30 (F2)
Pan size	mm	300 × 400				
Dimensions (W × D × H)	mm	321 × 546 × 120				
Net weight, approx.	kg	16.0				
Dust and water protection rating according to EN 60529*		IP44				

* = Specially protected dust-tight and washdown-resistant AC adapter; see the section on "Accessories."

Models Verified by the Manufacturer, with EC Type Approval

General Specifications

AC power source/power requirements	AC adapter, 230 or 115 V, +15% ... – 20%		
Frequency	48 – 60 Hz		
Adaptation to ambient conditions	By selection of 1 of 4 optimized filter levels		
Power consumption	16 VA: maximum; 9 VA: average		
Hours of operation with fully charged YRB 06 Z external battery pack, approx.	14 h		
Selectable application programs	Mass unit conversion, counting, weighing in percent, animal weighing, recalculation, calculation, density determination, differential weighing, checkweighing, time-controlled functions, totalizing, formulating, statistics, 2nd tare memory, IDs, product data memories		
Built-in interface	RS-232 C		
	Format:	7-bit ASCII, 1 start bit, 1 or 2 stop bits	
	Parity:	odd, even or space	
	Transmission rates:	150 to 19,200 baud	
	Handshake:	Software or hardware	

Specifications of the Individual Models:

Model		LA310S-OCE	LA230S-OCE	LA230P-OCE	LA120S-OCE
Type		isoTEST in conjunction with BC BF			
Accuracy class*		(I)	(I)	(I)	(I)
Scale interval, d*	mg	0.1	0.1	0.1/0.2/0.5	0.1
Maximum weighing capacity, Max*	g	310	230	60/120/230	120
Verification scale interval, e*	g	0.001			
Minimum capacity, Min*	g	0.01			
Tare range (subtractive)		≤ 100% of the maximum capacity			
Application range according to CD*	g	0.01 – 310	0.01 – 230	0.01 – 230	0.01 – 120
Response time (average)	s	2			
Allowable operating temperature		273 ... 313 K (0 ... +40 °C, 32 °F ... 104 °F) with isoCAL function			
Selectable weight units		Grams, milligrams			
External calibration weight value (of at least accuracy class...)	g	200 + 100 (E2)	200 (E2)	200 (E2)	100 (E2)
Other permissible external calibration weights (of at least accuracy class...)	g	200 (E2)	100, 150 (E2)	100, 150 (E2)	50 (E2)
Pan size	mm	∅ 90			
Dimensions (W × D × H)	mm	261 × 381 × 361			
Net weight approx.	kg	8.7			
Dust and water protection rating according to EN 60529 1)		IP42			

1) = Specially protected dust-tight and washdown-resistant AC adapter; see the section on “Accessories.”

* CD = Council Directive 90/384/EEC for non-automatic weighing instruments used within the European Economic Area

Model		LA1200S-OCE	LA620S-OCE	LA220S-OCE	LA620P-OCE
Type		isoTEST in conjunction with BD BF			
Accuracy class*		Ⓘ	Ⓙ	Ⓙ	Ⓙ
Scale interval, d*	g	0.001	0.001	0.001	0.001/0.002/0.005
Maximum weighing capacity, Max*	g	1,200	620	220	120/240/620
Verification scale interval, e*	g	0.01	0.01	0.01	0.01
Minimum capacity, Min*	g	0.1	0.02	0.02	0.02
Tare range (subtractive)		≤ 100% of the max. weighing capacity			
Application range according to CD*	g	0.1 – 1,200	0.02 – 620	0.02 – 220	0.02 – 620
Response time (average)	s	1.5			
Allowable operating temperature range		0 ... +40 °C (273 ... 313 K, 32 °F ... 104 °F) with the isoCAL function ¹⁾			
Selectable weight units		Grams, kilograms			
External calibration weight value (of at least accuracy class...)	g	1,000 (E2)			
Pan size	mm	∅ 130			
Dimensions (W × D × H)	mm	261 × 381 × 147			
Net weight, approx.	kg	8.3	6.9	6.9	6.9
Dust and water protection rating according to EN 60529 ²⁾		IP54			

Model		LA8200S-OCE	LA8200P-OCE	LA6200S-OCE	LA4200S-OCE	LA2200S-OCE
Type		isoTEST in conjunction with BD BF				
Accuracy class*		Ⓙ	Ⓙ	Ⓙ	Ⓙ	Ⓙ
Scale interval, d*	g	0.01	0.01/0.02/0.05	0.01	0.01	0.01
Maximum weighing capacity, Max*	g	8,200	2,000/4,000/8,200	6,200	4,200	2,200
Verification scale interval, e*	g	0.1	0.1	0.1	0.1	0.1
Minimum capacity, Min*	g	0.5	0.5	0.5	0.5	0.5
Tare range (subtractive)		≤ 100% of the max. weighing capacity				
Application range according to CD*	g	0.5 – 8,200	0.5 – 8,200	0.5 – 6,200	0.5 – 4,200	0.5 – 2,200
Response time (average)	s	2	2	1.5	1.5	1.5
Allowable operating temperature range		0 ... +40 °C (273 ... 313 K, 32 °F ... 104 °F) with the isoCAL function ¹⁾				
Selectable weight units		Grams, kilograms				
Pan size	mm	218 × 200				
Dimensions (W × D × H)	mm	261 × 381 × 86				
Net weight, approx.	kg	6.5				
Dust and water protection rating according to EN 60529 ²⁾		IP54				

¹⁾ = With the isoCAL function deactivated, the verified balance can only be used within the limited temperature range (can only be modified by the Sartorius Service Center): For balances of accuracy class Ⓘ: +15°C to +25°C (+59°F to +77°F)
For balances of accuracy class Ⓙ: +10°C to +30°C (+50°F to +86°F)

²⁾ = Specially protected dust-tight and washdown-resistant AC adapter; see the section on "Accessories."

* CD = Council Directive 90/384/EEC for non-automatic weighing instruments used within the European Economic Area

Model		LA820-OCE	LA2200P-OCE	LA5200P-OCE	LA12000S-OCE	LA6200-OCE	LA2200-OCE
Type		isoTEST in conjunction with BD BF					
Accuracy class*		Ⓐ	Ⓐ	Ⓐ	Ⓐ	Ⓐ	Ⓐ
Scale interval, d*	g	0.01	0.01/0.02/ 0.05	0.01/0.02/ 0.05/0.1	0.1	0.1	0.1
Maximum weighing capacity, Max*	g	820	400/800/ 2,200	1,200/2,400/ 3,800/5,200	12,000	6,200	2,200
Verification scale interval, e*	g	0.1	0.1	0.1	1	1	0.1
Minimum capacity, Min*	g	0.5	0.5	0.5	5	5	5
Tare range (subtractive)		≤ 100% of the max. weighing capacity					
Application range according to CD*	g	0.5 – 820	0.5 – 2,200	0.5 – 5,200	5 – 12,000	5 – 6,200	5 – 2,200
Response time (average)	s	1.5	1.5	1.5	1	1	1
Allowable operating temperature range		0 ... +40 °C (273 ... 313 K, 32 °F ... 104 °F) with the isoCAL function ¹⁾					
Selectable weight units		Grams, kilograms					
Pan size	mm	218 × 200					
Dimensions (W × D × H)	mm	261 × 381 × 86					
Net weight, approx.	kg	6.5					
Dust and water protection rating according to EN 60529 ²⁾		IP54					

Model		LA12000P-OCE	LA34001S-OCE	LA16001S-OCE	LA34001P-OCE	LA34000-OCE	
Type		isoTEST in conjunction with BD BF	isoTEST in conjunction with BF BF	isoTEST in conjunction with BF BF	isoTEST in conjunction with BF BF	isoTEST in conjunction with BF BF	
Accuracy class*		Ⓐ	Ⓐ	Ⓐ	Ⓐ	Ⓐ	
Scale interval, d*	g	0.1/0.2/0.5	0.1	0.1	0.1/0.2/0.5	1	
Maximum weighing capacity, Max*	kg	3/6/12	34	16	8/16/34	34	
Verification scale interval, e*	g	1	1	1	1	1	
Minimum capacity, Min*	g	5	5	5	5	50	
Tare range (subtractive)		≤ 100% of the max. weighing capacity					
Application range acc. to CD*	g	5 – 12,000	5 – 34,000	5 – 16,000	5 – 34,000	50 – 34,000	
Response time (average)	s	1	1.5	1.5	1.5	1	
Allowable operating temperature range		0 ... +40 °C (273 ... 313 K, 32 °F ... 104 °F) with the isoCAL function ¹⁾					
Selectable weight units		Grams and kilograms	Grams and kilograms	Grams and kilograms	Grams and kilograms	Kilograms	
Pan size	mm	218 × 200	300 × 400				
Dimensions (W × D × H)	mm	261 × 381 × 86	321 × 546 × 120	321 × 546 × 120	321 × 546 × 120	321 × 546 × 120	
Net weight, approx.	kg	6.5	16.0	16.0	16.0	16.0	
Dust and water protection rating According to EN 60529 ²⁾		IP54	IP44	IP44	IP44	IP44	

¹⁾ = With the isoCAL function deactivated, the verified balances can be used within the limited temperature range (can only be modified by the Sartorius Service Center):
For balances of accuracy class Ⓐ: +15°C to +25°C (+59°F to 77°F)
For balances of accuracy class Ⓐ: +10°C to +30°C (+50°F to 86°F)

²⁾ = Specially protected dust-tight and washdown-resistant AC adapter; see the section on "Accessories"

* CD = Council Directive 90/384/EWG for non-automatic weighing instruments used within the European Economic Area

Accessories (Options)

	Order No.		Order No.
Data printer , suitable for use in legal metrology; with date, time, statistics and transaction counter functions	YDP03-OCE	Weighing scoop Made of chrome-nickel steel, 90 mm × 32 mm × 8 mm	641214
Paper rolls , for YDP03-OCE; 5 units, each with 50 m	6906937	Ionizing blower 220 V for electrostatically charged samples 110 V	YIB01-ODR YIB01-OUR
Ink ribbon cartridge , for YDP03-OCE	6906918	Stat Pen , unit to neutralize static electricity on samples (100V to 230V, 50/60Hz)	YSTP01
External rechargeable battery pack , with battery level indicator	YRB06Z	Cable for connecting the weighing cell to a separate display and control unit (length: 2.70 m) – for balances with a weighing capacity ≤ 64 kg	YCC01-19M3
SartoConnect data transfer software; with RS-232C standard cable; for direct input of weighing data into an application program (e.g., such as Excel) with RS-232 C connecting cable, length 1 m with RS-232 C connecting cable, length 5 m with RS-232 C connecting cable, length 15 m	YSC01L YSC01L5 YSC01L15	Flow Rate Controller for pumps and feed units with analog or pulse interfaces	YFC02Z-V2
Foot switch , for activating the print, tare or F key; function can be selected by menu code; incl. T-connector	YFS01	Support arm, for raised display configuration – for balances with a weighing capacity ≤ 12 kg – for balances with a weighing capacity ≥ 16 kg	YDH01LP YDH02LP
Hand switch , for activating the print, tare or F key; function can be selected by menu code; incl. T-connector	YHS02	Bar code scanner (YCC01-0024M01 required)	YBR02FC
T-connector for connecting two peripheral devices to the balance	YTC01	Cable for connecting the bar code scanner	YCC01-0024M01
Balance table for precise, reliable weighing operations	YWT01	Standard Operating Procedure (SOP)	YSL01E
Cast stone table , with damping device	YWT03	RS-232C interface cable for connecting the balance to a PC with a 25-pin COM port; length approx. 1.5 m	7357312
Remote display LCD; height of digits: 13 mm; reflective	YRD02Z	RS-232C interface cable for connecting the balance to a PC with a 9-pin COM port; length approx. 1.5 m	7357314
Density determination kit for all 0.1 mg models for all 1 mg/10 mg models	YDK01 YDK01LP	RS-232 USB interface cable	YCC01-USBM2
Draft shield chamber with sliding doors for 1-mg LA models	YDS01LP	AC adapter ING-2 with IP65 protection rating for 230 V for 120 V	69 71899 69 71500
In-use dust cover – for models with a round weighing pan – for models with a rectangular weighing pan (weighing capacity ≤ 12.1kg)	Available on request Available on request	Antistatic pan for models with a readability of 0.1 mg	YWP01LA
3-segment checkweighing display red/green/red, for over/under checkweighing (light/heavy); incl. T-connector	YRD11Z	Hook for below-balance weighing for models LA34001S, LA16001S, LA34001P, LA34000	69EA0040
Carrying case , for all models, up to 12.1 kg	YDB01LP	Calibration weights for all LA balances; extensive assortment; available with certification	Information on request
Weighing bowls/pans/trays: Made of chrome-nickel steel; without pouring spout; for all models with a weighing capacity >400 g; – 1,000 ml capacity – 500 ml capacity	641211 641212		

Declarations of Conformity

The CE Mark on Sartorius Equipment

In 1985, the Council of the European Community approved a resolution concerning a new approach to the technical harmonization and standardization of national regulations. The organization for monitoring compliance with the directives and standards concerning the CE marking is governed in the individual EU Member States through the implementation of the EC Directives adopted by the respective national laws. As of December 1993, the scope of validity for all EC Directives has been extended to the Member States of the European Union and the Signatories of the Agreement on the European Economic Area.

Sartorius complies with the EC Directives and European Standards in order to supply its customers with weighing instruments that feature the latest advanced technology and provide many years of trouble-free service.

The CE mark may be affixed only to weighing instruments and associated equipment that comply with the applicable Directive(s):

Council Directive 89/336/EEC "Electromagnetic compatibility (EMC)"

1. Electromagnetic compatibility:

1.1 Reference to 89/336/EEC:
Official Journal of the European Communities, Nr. 2001/C105/03

EN 61326-1
Electrical equipment for measurement control and laboratory use EMC requirements

Parts 1: General requirements
Defined immunity to interference:
Industrial areas, continuous, un-monitored operation
Limitation of emissions:
Residential areas Class B

Important Note:

The operator shall be responsible for any modifications to Sartorius equipment and for any connections of cables or equipment not supplied by Sartorius and must check and, if necessary, correct these modifications and connections. On request, Sartorius will provide information on the minimum operating specifications (in accordance with the Standards listed above for defined immunity to interference).

Council Directive 73/23/EEC "Electrical Equipment Designed for Use within Certain Voltage Limits"

Applicable European Standards:

EN 60950
Safety of information technology equipment including electrical business equipment

EN 61010
Safety requirements for electrical equipment for measurement, control and laboratory use
Part 1: General requirements

If you use electrical equipment in installations and under ambient conditions requiring higher safety standards, you must comply with the provisions as specified in the applicable regulations for installation in your country.

Weighing Instruments for Use in Legal Metrology: Directive 90/384/EEC "Non-automatic weighing instruments"

This Directive regulates the determination of mass in legal metrology.

For the respective Declaration of Conformity for weighing instruments that have been verified by Sartorius for use as legal measuring instruments and that have an EC Type-Approval Certificate, see the page after next.

This Directive also regulates the performance of the EC verification by the manufacturer, provided that an EC Type-Approval Certificate has been issued and the manufacturer has been accredited by an officer or a Notified Body registered at the Commission of the European Community for performing such verification.

The legal basis allowing Sartorius to perform EC verification is constituted by the EC Council Directive No. 90/384/EEC on non-automatic weighing instruments that has been in effect since January 1, 1993, in the Internal Market as well as by the Certificate of Accreditation of the Sartorius AG Quality Management System issued by the Metrology Department of the Regional Administration Office of Lower Saxony, Germany ("Niedersächsisches Landesverwaltungsamt -Eichwesen") on February 15, 1993.

For information on the CE mark on Sartorius equipment and legal regulations currently applicable in your country, and to obtain the names of the persons to contact, please ask your local Sartorius office, dealer or service center.

"New Installation" Service

Initial verification is covered in our "New Installation" service package. In addition to initial verification, this package provides you with a series of important services which will guarantee that you achieve optimal results with your weighing instrument:

- Installation
- Startup
- Inspection
- Training
- Initial verification

If you would like Sartorius to perform initial verification of your weighing instrument, contact an authorized service representative.

"EC Verification" – A Service Offered by Sartorius

Our service technicians are authorized to perform verification* of your weighing instruments that are acceptable for legal metrological verification and can inspect and verify the metrological specifications at the place of installation within the Member States of the European Union and the Signatories of the Agreement on the European Economic Area.

Subsequent Verifications within the European Countries

The expiration date of the verification depends on the national regulations of the country in which the weighing instrument is used. For information on verification and legal regulations currently applicable in your country, and to obtain the names of the persons to contact, please contact your local Sartorius office, dealer or service center.

* in accordance with the accreditation certificate issued to Sartorius AG

CE Declaration of Type Conformity to Directive No. 90/384/EEC

This declaration is valid for non-automatic electromechanical weighing instruments for use in legal metrology. These weighing instruments accepted for legal metrological verification have an EC Type-Approval Certificate. The model(s) concerned is(are) listed below along with the respective type, accuracy class, and number of the EC Type-Approval Certificate:

Model	Weighing instrument type	Accuracy Class	EC Type Approval No.	In Conjunction with Test Certificate	
				Type	Certificate No.
LA...-0CE	iso-TEST	I	D97-09-018	BC BF	D09-96.30
LA...-0CE	iso-TEST	I, II	D97-09-018	BD BF	D09-96.30
LA...-0CE	iso-TEST	II	D97-09-018	BF BF	D09-96.30

SARTORIUS AG declares that its weighing instrument types comply with the requirements of the Council Directive on non-automatic weighing instruments, no. 90/384/EEC of 20 June 1990; the associated European Standard "Metrological aspects of non-automatic weighing instruments," No. EN 45501; the amended, currently valid versions of the national laws and decrees concerning legal metrology and verification in the Member States of the European Union, the EU, and the Signatories of the Agreement on the European Economic Area, which have adopted this Council Directive into their national laws; and with the requirements stipulated on the Type-Approval Certificate for verification. This Declaration of Type Conformity is valid only if the ID label on the weighing instrument has the CE mark of conformity and the green metrology

sticker with the stamped letter "M" (the two-digit number in large print stands for the year in which the mark has been affixed):



If these marks are not on the ID label, this Declaration of Type Conformity is not valid. Validity can be obtained, for example, by submitting the weighing instrument for final action to be taken by an authorized representative of SARTORIUS AG. The period of validity of this Declaration of Type Conformity shall expire upon any tampering with, repair or modification of this weighing instrument or, in some Member States, on the date of expiration. This declaration applies only to the weighing instrument without peripheral devices.

The operator of this weighing instrument shall be responsible for obtaining an authorized renewal of the verification, such as subsequent or periodic verification, of the weighing instrument for use as a legal measuring instrument.

Sartorius AG
37070 Goettingen, Germany
Signed in Göttingen, 29.05.2006

Dr. G. Maaz
President of the Mechatronics Division

J. Rehwald
Head of the Production Department
Mechatronics / Weighing Technology Division

Physikalisch-Technische Bundesanstalt

Braunschweig und Berlin

PTB



EG-Bauartzulassung

EC type-approval certificate

Zulassungsinhaber:

Sartorius AG

Issued to:

Weender Landstr. 94-108
37075 Göttingen

Rechtsbezug:

In accordance with:

§ 13 des Gesetzes über das Mess- und Eichwesen (*verification act*) vom/dated 23. März 1992 (BGBl. I S. 711), zuletzt geändert am (*last amended on*) 25.11.2003 (BGBl. I S. 2304), in Verbindung mit Richtlinie (*in connection with council directive*) 90/384/EWG, geändert durch (*amended by*) 93/68/EWG

Bauart:

In respect of:

Nichtselbsttätige elektromechanische Waage mit oder ohne Hebelwerk
Nonautomatic electromechanical weighing instrument with or without leverwork

Typ / Type:

iso-TEST

Genauigkeitsklasse/class (I), (II), (III), (III) Max 2,1 g ... 300 t

Option: Mehrteilungswaage, Mehrbereichswaage

Multi-interval instrument, multiple range instrument

Zulassungsnummer:

D97-09-018 6. Revision

Approval number:

Gültig bis:

26.06.2007

Valid until:

Anzahl der Seiten:

16

Number of pages:

Geschäftszeichen:

PTB-1.12-4023683

Reference No.:

Benannte Stelle:

0102

Notified Body:

Im Auftrag

By order

Marcus Link



Braunschweig, 22.05.2006

Siegel
Seal

Die Hauptmerkmale, Zulassungsbedingungen und Auflagen sind in der Anlage enthalten, die Bestandteil der Revision der EG-Bauartzulassung ist. Hinweise und eine Rechtsbehelfsbelehrung befinden sich auf der ersten Seite der Anlage

The principal characteristics, approval conditions and special conditions, if any, are set out in the Annex which forms an integral part of this Revision of the EC type-approval certificate. For notes and information on legal remedies, see first page of the Annex.

Physikalisch-Technische Bundesanstalt

Braunschweig und Berlin

PTB



Prüfschein

Test certificate

Ausgestellt für:

Issued to:

Sartorius AG
Weender Landstraße 94 – 108
37075 Göttingen
Bundesrepublik Deutschland

Prüfgrundlage:

In accordance with:

EN 45501 (1992), Nr.8.1, OIML R 76-1 (1992)

Gegenstand:

Object:

Lastaufnehmer mit Wägezelle und Auswerteelektronik mit digitalem Ausgang als Modul einer elektromechanischen Waage zum Anschluß an geeignete Anzeige- und Bedienterminals
Load receptor with load cell and electronic device with digital output as module of an electromechanical weighing instrument for connection to suitable display- and operator-terminals
Typ / type **BA BF, BC BF, BD BF, BF BF, HC BF, MA BF und MD BF**

Kennummer:

Serial number:

Prüfscheinnummer:

Test certificate number:

D09-96.30 7. Revision / *Revision 7*

Datum der Prüfung:

Date of Test:

Anzahl der Seiten:

Number of pages:

12

Geschäftszeichen:

Reference No.:

1.14 – 02001430

Benannte Stelle:

Notified Body:

0102

Im Auftrag

By order

Link

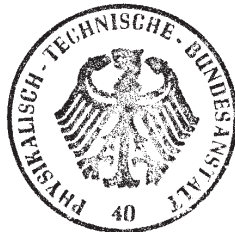

Braunschweig, 2002-11-13

Siegel

Seal

Index

	Page		Page		Page
Accessories (options)	140	EC type-approval certificate	143	Recycling instructions	128
Acoustic signal	39	Emulation MP8 interface	39	Reference sample updating	52
Additional functions	97	Enter/change password	18	Remote display	9
Animal weighing	57	Equipment supplied	9	Repairs	127
Antitheft device	11	Error codes and messages	124	Replacing the dust cover	127
Application filter	16	External calibration	46	Reset factory settings – menu	20, 34, 39
Application programs	49	Factory settings	20, 34, 98	Safety inspection	127
Applications menu	22	FlexPrint	31	Safety precautions	3, 10
Applications, combining	111	Formulation	90	Second tare memory (preset tare)	97
Applications, configuring	22	General password	Appendix	Service	127
Auto print functions	31	General view of balances	129	Soft keys	4
Auto start application with power-on	49	Handshake mode	121	Software handshake	121
Auto zero	16	Identifiers	99	Specifications	133
Balance menu	16	Input	5, 14	SQmin function	106
Balance, automatic shutoff	21	Intended use	2	Statistics	93
Balance, installation	8	Installation	7	Storage and shipping conditions	7
Balance-specific information	34	Interface port	117	Symbols in display	113
Bar code scanner	38	Interface port, input/output	118	Synchronization	121
Bar graph	113	Internal calibration	45	Time-controlled functions	84
Basic weighing functions	35	ISO/GLP printout/record	116	Toggling between weight units	49
Below-balance weighing	35	isoCAL function	47	Totalizing	86
Block printout	48	Keypad	3, 39	Universal remote control switch	38
Cabling diagram	123	Language setting	12	Unpacking the balance	7
Calculation	61	Leveling the balance	11	User data, input	5
Calibration/adjustment	40	Line format	31, 115	User password	Appendix
Calibration/adjustment, automatic	46	Manual storage – M+	104	Warmup time	10
Care and maintenance	127	Manual/automatic print mode	30	Warnings and safety precautions	3
Checkweighing	79	Menu – reset factory settings	20, 34, 39	Weighing in percent	54
Cleaning the balance	127	Menu parameters – read only	30	Weighing series number	120
Combining applications	110	Metrological data, in display	113	Weight set number	16, 120
Configuring applications	22	MP8 interface emulation	39	Workstation number	120
Configuration	12	Operating design	3		
Configuring printouts	32	Operation	35		
Connecting to AC power	10	Options	140		
Contents	2	Overview of Application menu	23		
Contrast, display	21	Parameter settings	22		
Control port	38, 80	Parameters in menu – read only	30		
Counting	51	Password, enter/change	18		
Data output functions	113	Password, general	Appendix		
Data ID codes	99	Pin assignment chart	123		
Data input format	131	Plates and Markings	145		
Data interface port	118	Power-on mode	39		
Data output format	118	Preset tare (2nd tare memory)	97		
Data output, following print command	121	Print application parameters	30		
Data output, initialize	121	Print manually/automatically	30		
Declaration of conformity	141	Printouts	115		
Density determination	63	Printout configuration	30, 32		
Display	4, 39, 113	Product data memory	104		
Display backlighting	120				
Display, remote	9				
DKD uncertainty of measurement	108				
Dustcover, replacing	127				

Entering the General Password

Enter/Change Password

- Select the Setup menu: Press ↓

> **SETUP SELECTION**
is displayed

- Select the user input function:
Press the **Input** soft key

> The password prompt
is displayed:

SETUP	PASSW.CHECK
Enter password:	██████████
<<	↓

- Enter the General Password
(see below)
- Confirm password:
Press the ↓ soft key
- > User data is displayed

- Select the password setting function:
Press the **↵** soft key repeatedly until

> **Enter password:**
is displayed, together with the current
password setting

- Define a new password:
Enter letters/numbers for the new password (8 characters max.)
To delete the current password: press **⋅** and confirm

- To confirm the new password: press the **↓** soft key

- Exit the Setup menu:
Press the **⏪** soft key

> Restart your application

General Password:
40414243

Sartorius AG
Weender Landstrasse 94–108
37075 Goettingen, Germany

Phone +49.551.308.0
Fax +49.551.308.3289
www.sartorius.com

Copyright by Sartorius AG,
Goettingen, Germany.
All rights reserved. No part
of this publication may
be reprinted or translated in
any form or by any means
without the prior written
permission of Sartorius AG.
The status of the information,
specifications and illustrations
in this manual is indicated
by the date given below.
Sartorius AG reserves the
right to make changes to the
technology, features,
specifications and design of the
equipment without notice.

Status:
June 2007, Sartorius AG,
Goettingen, Germany