

APPLANATION TONOMETER

INSTRUCTIONS FOR USE

Z800 / F900 / A900

1	INTRODUCTION	3
1.1	SYMBOLS	3
1.1.1	<i>Device symbols</i>	4
1.2	GENERAL WARNINGS	4
1.3	NORMATIVE REFERENCES	5
1.3.1	<i>Community directives</i>	5
1.3.2	<i>Technical standards</i>	5
1.3.3	<i>Quality management systems standards</i>	5
1.4	WARRANTY	6
1.5	MANUFACTURER IDENTIFICATION	7
2	SAFETY	8
2.1	SAFETY WARNINGS	8
2.2	DEVICE IDENTIFICATION	11
2.2.1	<i>Registration data in the Medical Devices List</i>	11
2.2.2	<i>Device data plate</i>	11
2.3	INTENDED USE	12
2.4	MEDICAL DEVICES CLASSIFICATION	13
2.5	MEDICAL ELECTRICAL DEVICES CLASSIFICATION	14
2.6	ENVIRONMENTAL CONDITIONS	14
2.7	DISPOSAL AT THE END THE USEFUL LIFE	15
3	DEVICE DESCRIPTION	17
3.1	PROVISION DESCRIPTION	17
3.1.1	<i>Tonometer Z800</i>	20
3.1.2	<i>Tonometer A900</i>	21
3.1.3	<i>Tonometer F900</i>	22
3.2	TECHNICAL DATA	23
4	DEVICE USE	24
4.1	HOW TO INSTALL THE TONOMETER Z800 ON THE SLIT LAMP	24
4.2	HOW TO INSTALL THE TONOMETER A900 ON THE SLIT LAMP	25
4.3	HOW TO INSTALL THE TONOMETER F900 ON THE SLIT LAMP	27
4.4	HOW TO PREPARE THE SLIT LAMP (Z800)	28
4.5	HOW TO PREPARE THE SLIT LAMP (A900)	29
4.6	HOW TO PREPARE THE SLIT LAMP (F900)	29
4.7	HOW TO PLACE THE MEASURING PRISM	30
4.7.1	<i>How to place the reusable measuring prism</i>	31
4.7.2	<i>How to place the disposable measuring prism</i>	32
4.8	HOW TO PREPARE THE PATIENT	33
4.9	HOW TO MEASURE THE INTRAOCULAR PRESSURE	34
4.10	HOW TO MEASURE THE INTRAOCULAR PRESSURE IN ASTIGMATIC PATIENTS	35
4.11	CORRECTING THE WRONG ACQUISITIONS	36
4.12	HOW TO READ THE MEASURING SCALE	40









4.13	HOW TO REMOVE THE MEASURING PRISM	41
4.14	HOW TO REMOVE THE TONOMETER Z800 FROM THE SLIT LAMP	42
4.15	HOW TO REMOVE THE TONOMETER A900 FROM THE SLIT LAMP	42
4.16	HOW TO REMOVE THE TONOMETER F900 FROM THE SLIT LAMP	42
5	ORDINARY MAINTENANCE	43
5.1	SAFETY WARNINGS	43
5.2	DEVICE CLEANING	44
5.3	MEASURING PRISM CLEANING	45
5.3.1	<i>Measuring prism disinfection</i>	46
5.4	TONOMETER FUNCTIONING CHECK	49
5.4.1	<i>Functioning control with measuring knob on 0</i>	50
5.4.2	<i>Functioning control with measuring knob on 2</i>	52
5.4.3	<i>Functioning control with measuring knob on 6</i>	54
5.5	SPARE PARTS AND ACCESSORIES LIST	56
5.6	TROUBLESHOOTING	58

1 INTRODUCTION

The device is the result of a long research period, conducted by experts to give the product technical innovation, quality and design. The device can be easily used in ophthalmology to measure the inter-ocular eye pressure.

1.1 SYMBOLS

Within the instructions for use, on the package or on the device, there can be the following symbols:

Symbol	Meaning
	Caution
	Read the instructions for use
	General mandatory action sign
	Note. Useful information for the user
	General prohibition sign
	Manufacturer
	CE Marking (Directive 93/42/EEC) Identification number of the notified body (IMQ)

1.1.1 DEVICE SYMBOLS

Symbol	Meaning
	Type B applied part
	Class I equipment

1.2 GENERAL WARNINGS

THIS INSTRUCTIONS FOR USE IS REFERRED TO THE DEVICES Z800, F900 AND A900.

THE DEVICE Z800 IS AN ACCESSORY COMPATIBLE WITH THE SLIT LAMP SL9800.

THE DEVICES A900 AND F900 ARE ACCESSORIES COMPATIBLE WITH THE SLIT LAMP SL9900.



Within the instructions for use, the devices are identified by Z800, F900 or A900.

When not specified, the indications are applicable to all the devices.

THE ORIGINAL TEXT IS IN ITALIAN.



Before using the device or if you don't use it since a long time, read these instructions carefully. Read the instructions given in the instructions manual and reported on the device.



Keep this manual close by for future consultation. If you should decide to sell this appliance to other people, remember to also include these instructions, complete and readable



Keep the original box and packaging, as the free-of-charge service does not cover any damage resulting from inadequate packaging of the product when this is sent back to an Authorized Service Center.



Before using the device check that there is no sign of damages due to transport or an incorrect storage, that could compromise the correct functioning of the device.



It is forbidden to reproduce, totally or partially, texts or images contained in these instructions for use without the written authorization of the Manufacturer.



The Manufacturer reserves himself the right to modify the contents of the instructions for use, without notice.

1.3 NORMATIVE REFERENCES

1.3.1 COMMUNITY DIRECTIVES

- Directive 93/42/EEC and subsequent modifications and integrations concerning medical devices
- Directive 2008/98/EC on waste

1.3.2 TECHNICAL STANDARDS

- IEC 60601-1: 2005 + A1:2012 - Medical electrical equipment - Part 1: General requirements for basic safety and essential performance.
- UNI EN ISO 15004-1:2009 - Ophthalmic Instruments. Fundamental requirements and test methods - Part 1: General requirements applicable to all ophthalmic instruments.
- UNI CEI EN ISO 14971:2012 - Medical devices. Application of risk management to medical devices.
- UNI EN ISO 8612:2009 "Ophthalmic instruments - Tonometers".

1.3.3 QUALITY MANAGEMENT SYSTEMS STANDARDS

- UNI CEI EN ISO 13845:2016 - Medical devices. Quality management systems - Requirements for regulatory purposes

1.4 WARRANTY

The Manufacturer is responsible for the device conformity to the Community directive 93/42/EEC as amended by the 2007/47/EC for:

- features
- safety and reliability
- CE marking

The Manufacturer refuses any responsibility for:

- installation and activation not activated in conformity to the indications and the precautions reported in the instructions for use
- use not in compliance with the instructions for use and precautions reported in the instructions for use
- use of accessories or spare parts not provided or suggested by the Manufacturer
- repairs and safety controls not effectuated by expert, qualified, trained and personnel authorized by the Manufacturer
- electrical system of the space where the device is installed not in compliance with the technical standards, the laws and regulations in effect in the country of installation of the device
- direct or indirect consequences or damages to objects or persons, originating from the improper use of the device or erroneous clinical analysis originating from its use

The Manufacturer guarantees the device for 24 months after invoicing. The Warranty includes the substitution, at the Manufacturer's or an Authorized Service Center, of components and materials and the relative labor. The shipping and transport fees are to be paid by the client.

The warranty does not cover:

- reparations of faults originating from natural disasters, mechanical shocks (fall, hit, etc), negligence, improper use, maintenance or reparations carried out with non-original materials
- any other improper use or not intended by the Manufacturer
- damages caused by service lack or inefficiency, originating by causes or circumstances out of the Manufacturers control

- the parts subject to usage and/or deterioration originating from the normal use and those that might be broken because of an improper use or maintenance carried out by personnel non-authorized by the Manufacturer.

To ask maintenance interventions or to have technical information about the device, address to an Authorized Service Center or directly to the device Manufacturer.



The client will not be refunded for damages originating from the device halt.

1.5 MANUFACTURER IDENTIFICATION

CSO S.r.l.

Costruzione Strumenti Oftalmici

Via degli Stagnacci, 12/E

50018 - Scandicci (FI) - ITALY

phone: +39-055-722191 - fax +39-055-721557

cso@csoitalia.it

www.csoitalia.it

2 SAFETY

2.1 SAFETY WARNINGS



CAUTION

Do not use the device if visibly damaged. Periodically inspect the device to verify if there are damage signs.



CAUTION

Always keep the device out of the reach of children.



CAUTION

Danger of device fall. Check that the device is correctly fixed on the slit lamp. Pay attention during the device assembly operations. In case of accidental fall, check the calibration and, if necessary, contact the Manufacturer.



CAUTION

Before any measurement the contact surface of the measuring prism must be inspected for damages. If there is any anomaly, replace the prism.

**CAUTION**

The measurement has to be carried out only with intact, clean and disinfected prisms. Otherwise you could damage the patient's cornea.

If the measuring prism is not intact, detergent or disinfectant products residuals could enter the cracks and cause, during the measurement, irritations and corrosion on the corneal surface. Hence the prism has to be accurately rinsed with water after disinfection and must be checked to be sure of its integrity.

Moreover, a wrong disinfection can cause cross-contamination between patients and operator and damages to the measuring prism.

For indications on the cleaning and disinfection procedures refer to the paragraph Measuring prism disinfection at page 46.



If you use a reusable measuring prism, always disinfect it before carrying of the measurement on the patient's eye surface and immediately after the exam.

If you use a disposable measuring prism, before use always make sure the package is intact and the content is sterile. Immediately after the exam make sure to dispose of the disposable prism.

**CAUTION**

If possible, avoid to carry out the measurement in case the patient presents ocular infection or injured corneal surface



Touch the measuring prism only with disposable gloves. Touch the prism only from the sides and never from the part that will be in contact with the patient's eye surface.



The measuring prism shall not be disinfected with other instruments or medical devices.



Do not use the measuring prism beyond two years from the date indicated on the production batch written on the package.



For patients affected by infective diseases always use the disposable prisms.



It is forbidden to disinfect and reuse the disposable prisms.



It is forbidden to carry out any technical operation on the device that is not recalled or described in the instructions for use.



It is forbidden to place the device in humid, dusty places or environments subject to sudden temperature and humidity variations.



It is forbidden to use the device outdoors.



The measurement precision is influenced by corneal rigidity variations and changes. The rigidity can be due to differences in the corneal thickness, to intrinsic structural factors or refractive corneal surgery. Keep these factors into account during the evaluation of the intraocular pressure.



The device does not generate and does not receive any electromagnetic interference if it is placed near other electrical appliances. No preventive or corrective actions are required.

2.2 DEVICE IDENTIFICATION

2.2.1 REGISTRATION DATA IN THE MEDICAL DEVICES LIST

CND (national medical devices classification)

Repertoire number (progressive system number attributed to the device)

Market release date

The device registration data can be verified on the Ministero della Salute website on this page:

[Ministero della Salute - Ricerca dispositivi](#)

2.2.2 DEVICE DATA PLATE

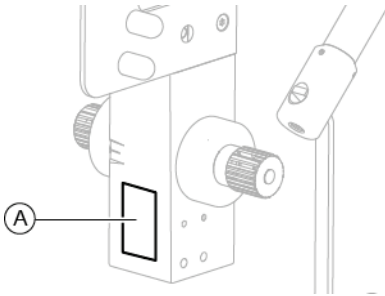

Fig 1 - Plate position tonometer Z800

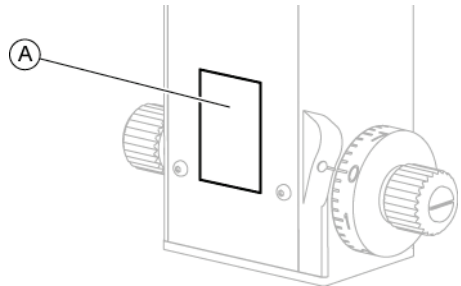

Fig 2 - Plate position tonometer A900

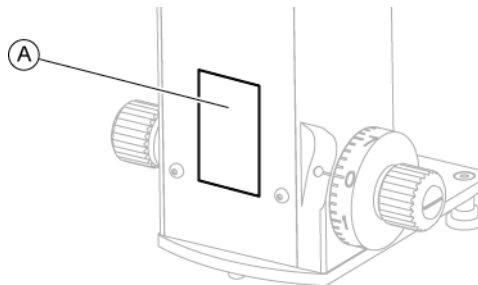

Fig 3 - Plate position tonometer F900

Pos	Description
A	Device data plate



Fig 4 - Data plate for tonometer Z800 Fig 5 - Data plate for tonometer A900



Fig 6 - Data plate for tonometer F900

2.3 INTENDED USE

The applanation tonometer is an accessory device for the slit lamps that enables to measure the eye pressure, for the diagnosis of some ophthalmological diseases, especially the exam and the glaucoma diagnosis.

The applanation tonometer functions according to the 'Goldmann method': the measurement of the intraocular pressure is given by the required force to maintain a uniform applanation of the corneal surface.

The intraocular pressure measurement is conducted on the patient by means of the measuring prism in contact with the patient's cornea. During the exam the measuring prism is installed on the tonometer arm support. The tonometer is installed on the slit lamp.

Because of the direct contact with the corneal surface, it could be necessary to apply a local anesthetic in the patient's eye.

High precision measurement device. The average deviation (standard) in every single exam is $\pm 0,5$ mmHg circa.

The scleral stiffness shall not be considered because the small volumetric displacement of $0,56 \text{ mm}^3$ increases the intraocular tension of only the 2,5% circa.

The tonometers have to be installed on the slit lamp by means of their support accessory.

The tonometers A900 and Z800 can be left on the slit lamp even when they are not in use, and if necessary, they can be placed in front of the microscope during the exam.



The CSO applanation tonometer is suitable for the majority of slit lamps from other suppliers.

2.4 MEDICAL DEVICES CLASSIFICATION

Technical data	Value
Classification in compliance with the attached IX to the Directive 93/42/EEC and successive modifications	Class Im

2.5 MEDICAL ELECTRICAL DEVICES CLASSIFICATION

Classification in compliance with the technical specification EN 60601-1:2005 + A1:2012

Technical data	Value
Type of protection against the direct and indirect contacts	Class I
Applied parts	Type B
Protection degree against humidity	IP20 (no protection against liquid infiltration)
Sterilization or disinfection method	This device can be disinfected
Protection degree in presence of anesthetics or inflammable detergents	No protection
Electrical connection degree between device and patient	Appliances with part applied on the patient
Use conditions	Continuous functioning

2.6 ENVIRONMENTAL CONDITIONS

Phase	Technical data	Min	Max
Transport	Temperature	-10°C	+60°C
	Atmospheric pressure	500 hPa	1060 hPa
	Relative humidity	10%	90%
Storage	Temperature	-10°C	+60°C
	Atmospheric pressure	500 hPa	1060 hPa
	Relative humidity	10%	90%
Use	Temperature	+15°C	+30°C
	Atmospheric pressure	700 hPa	1060 hPa
	Relative humidity	30%	70%

**CAUTION**

Danger of device damages. During transport and storage, the device can be exposed to the environmental conditions for a maximum period of 15 weeks, only if kept in the original packaging.

2.7 DISPOSAL AT THE END THE USEFUL LIFE

Instruction for disposal of product correctly according to European Directive 2008/98/EC on waste.

At the end of its useful life, the device must not be disposed of as urban waste. The device can be delivered to the appropriate separate waste collection centers set up by municipal administrations or to retailers that offer this service. Separately disposing a device prevents possible negative consequences for the environment and health caused by its improper disposal, and lets the materials it is made of to be recycled so as to achieve a significant savings of energy and resources.



The user has to consider the effects potentially dangerous for the environment and the human health originating from an improper disposal of the whole device or its parts.

In case the user wishes to dispose of the device used at the end of its useful life, the Manufacturer facilitates the possibility of its reuse and the recovery and recycling of the materials contained therein. This to prevent the release of hazardous substances into the environment and to promote conservation of natural resources. Before disposing the device, it is necessary to take into consideration the European and national regulations that order what follows:

- not to dispose as urban waste but collect it separately and address to a firm specialized or to the local administration in charge for waste collection.

- in the event that a new device is purchased from the same Manufacturer to replace an old one placed on the market before 13 August 2005, equivalent and with the same functions of the new device, the Distributor or Manufacturer are legally required to collect the old device.
- if the user decides to dispose a used device, put on the market after the 13th August 2005, the Distributor or the Manufacturer have to collect it.
- the Manufacturer takes care, by joining a consortium for the technological devices waste, of the treatment and the recycling of the used device by paying its costs.



The Manufacturer is available to give the user all the information about the dangerous substances contained in the device, and on the recycling modalities of those substances and about the possibility of a reuse of the used device.

Strict sanctions for transgressors are provided for by law.

For specific information about the disposal in other countries than Italy, contact the local Dealer.

3 DEVICE DESCRIPTION

3.1 PROVISION DESCRIPTION

Device Z800

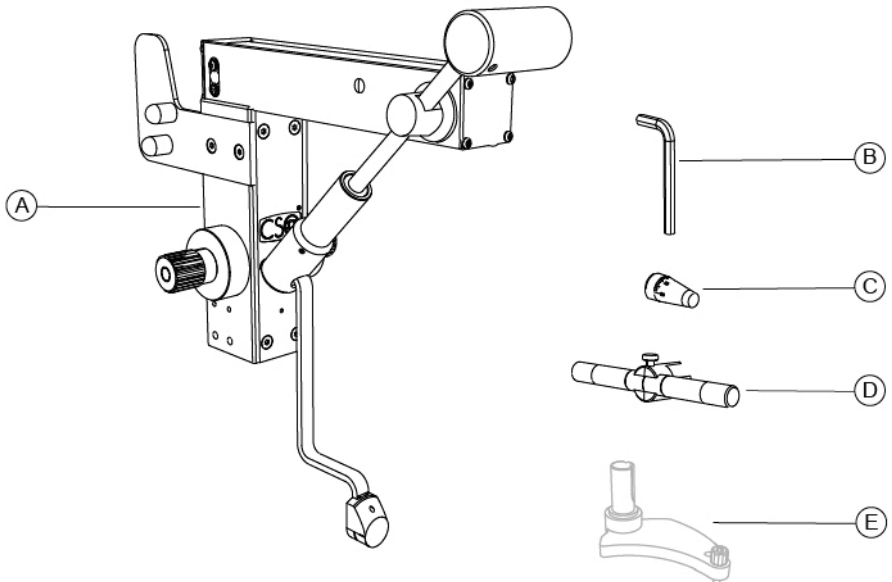

Fig 7 - Provision description

Pos	Denomination
A	Device
B	Hex key
C	Measuring prism
D	Functioning control accessory
E	Tonometer support (optional)

Device A900

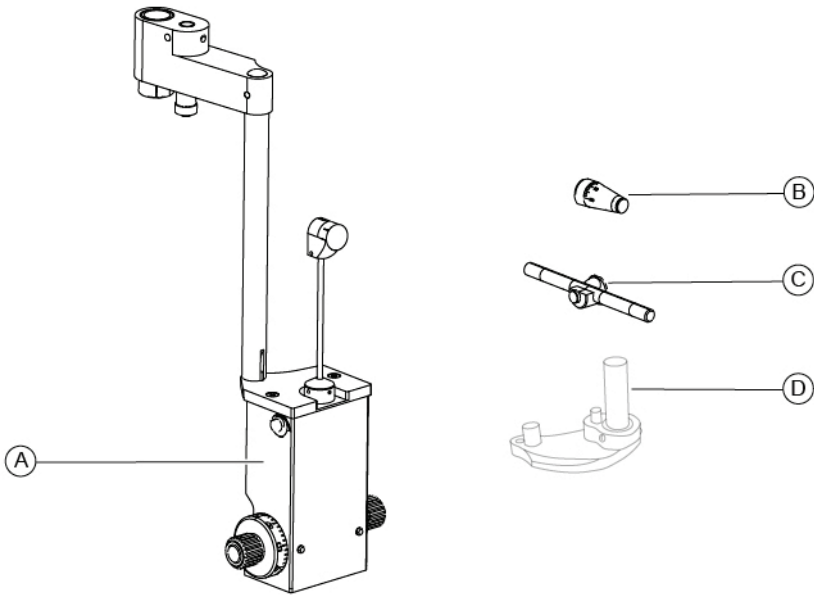

Fig 8 - Provision description

Pos	Denomination
A	Device
B	Measuring prism
C	Functioning control accessory
D	Tonometer support (optional)

Device F900

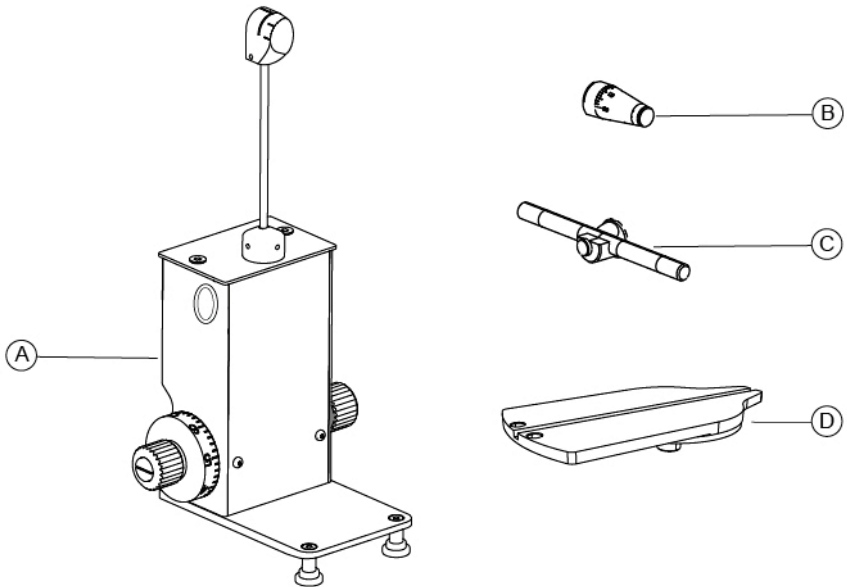

Fig 9 - Provision description

Pos	Denomination
A	Device
B	Measuring prism
C	Functioning control accessory
D	Tonometer support guide



For the list of accessories and available models contact the Manufacturer or the local Distributor.

3.1.1 TONOMETER Z800

Fig 10 - Tonometer Z800

Pos	Description
A	Resting arm support
B	Tonometer Z800 body
C	Measuring scale knob
D	Arm
E	Measuring prism support
F	Functioning control accessory snap-fit compartment

3.1.2 TONOMETER A900

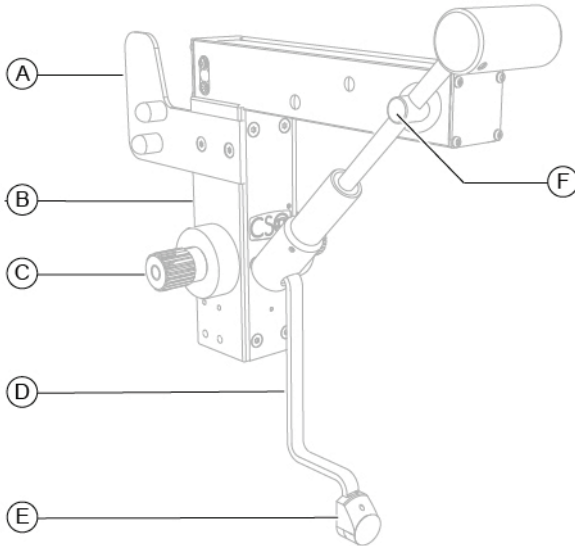
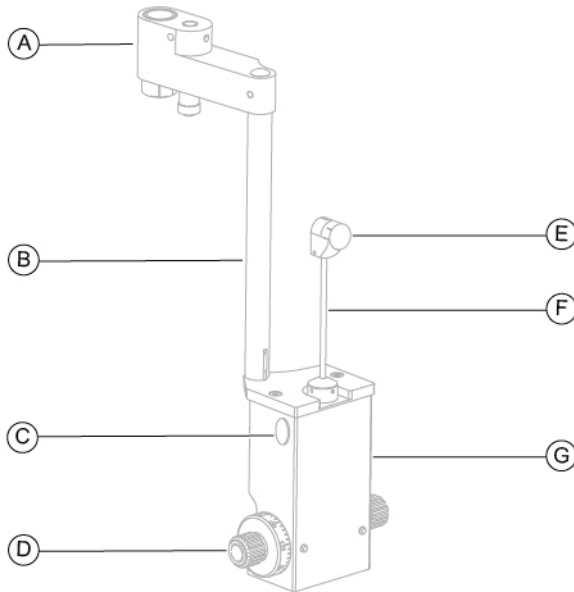

Fig 11 - Tonometer A900

Pos	Description
A	Fixing connection for tonometer A900
B	Connection support
C	Functioning control accessory snap-fit compartment
D	Measuring scale knob
E	Measuring prism support
F	Arm
G	Tonometer A900 body

3.1.3 TONOMETER F900

Fig 12 - Tonometer F900

Pos	Description
A	Measuring prism support
B	Functioning control accessory snap-fit compartment
C	Measuring scale knob
D	Support
E	Tonometer F900 body
F	Arm

3.2 TECHNICAL DATA

Tonometer Z800

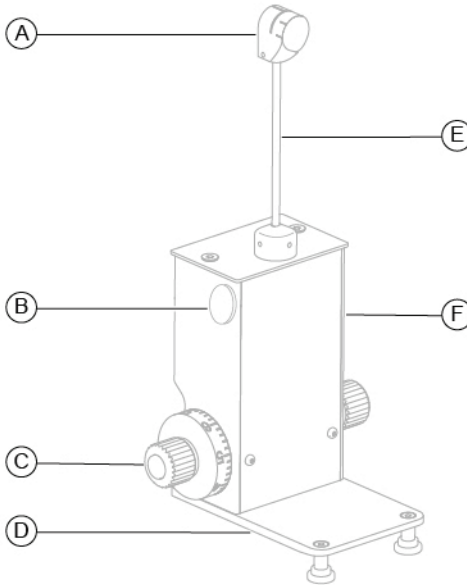
Technical data	Value
Measuring force	Produced by the spring force
Installation	On the support pivot on top of the slit lamp microscope
Measurement range	Between 0 and 80 mmHg (between 0 and 10,64 kPa)
Backlash width	$\leq 0,25$ mN
Weight	0,85 kg (without accessories)

Tonometer A900

Technical data	Value
Measuring force	Produced by the spring force
Installation	On the support pivot on top of the slit lamp microscope
Measurement range	Between 0 and 80 mmHg (between 0 and 10,64 kPa)
Backlash width	$\leq 0,49$ mN
Weight	0,82 kg (without accessories)

Tonometer F900

Technical data	Value
Measuring force	Produced by the spring force
Installation	Inserting the guide on the slit lamp arm
Measurement range	Between 0 and 80 mmHg (between 0 and 10,64 kPa)
Backlash width	$\leq 0,49$ mN
Weight	0,48 kg (without accessories)

4 DEVICE USE

4.1 HOW TO INSTALL THE TONOMETER Z800 ON THE SLIT LAMP

- 1 Install the tonometer support on top of the microscope, on its compartment. Block it with the screw on the device.
- 2 Place the tonometer on the support pivot. The tonometer arm must face the patient.

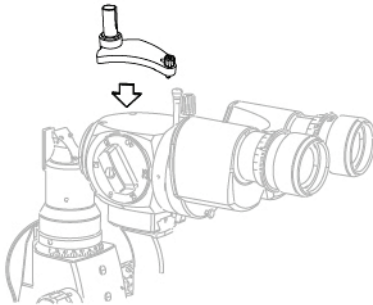

Fig 13 - How to place the tonometer support

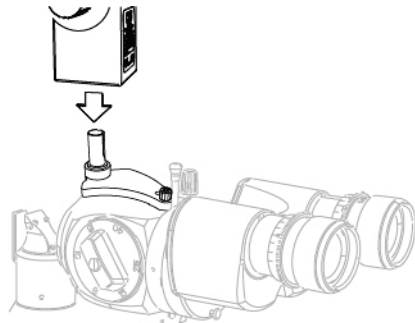

Fig 14 - How to place the tonometer Z800

- 3 Free the arm from the protection support and move it from the resting position to the measurement position.
- 4 If necessary adjust the measuring prism support position to align it with the microscope shooting channel. Block the tonometer by means of the screws placed under the measuring scale knob.

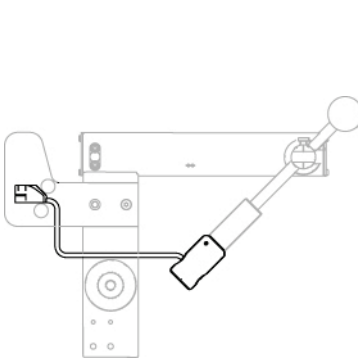

Fig 15 - Arm in resting position

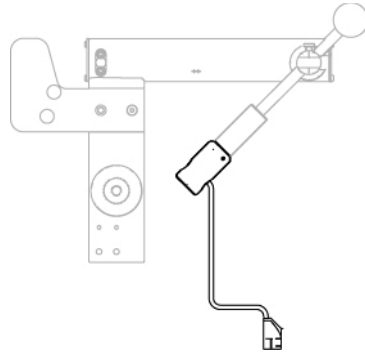

Fig 16 - Arm in measurement position

4.2 HOW TO INSTALL THE TONOMETER A900 ON THE SLIT LAMP

- 1 Turn the lighting head of the slit lamp on the left or on the right oriented with a 90° angle.
- 2 Place the tonometer support on top of the microscope, on its compartment. Block it with the screw on the device.
- 3 Place the tonometer A900 connection support on the tonometer support.

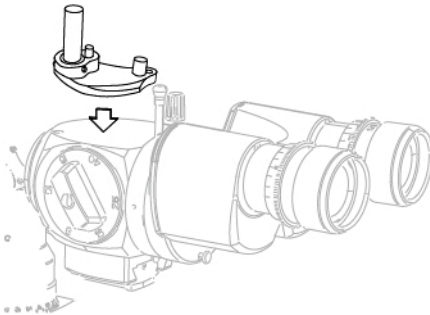

Fig 17 - How to place the tonometer support

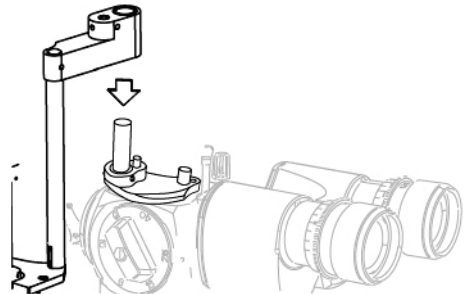

Fig 18 - How to place the tonometer A900

- 4 Turn the tonometer and place the measuring prism in measurement position. The blocking position ensures the correct position of the tonometer during the measurement.

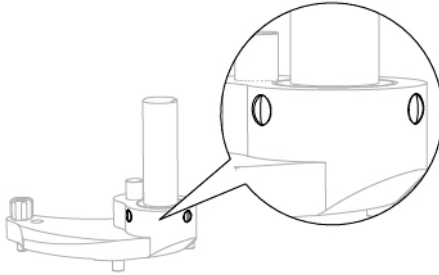

Fig 19 - Blocking position measurement/rest

4.3 HOW TO INSTALL THE TONOMETER F900 ON THE SLIT LAMP

- 1 Turn the lighting head of the slit lamp on the left or on the right oriented with a 90° angle.
- 2 Remove the lid on the slit lamp arm and place the support in its seat.
- 3 Place the tonometer F900 on the tonometer support guide.

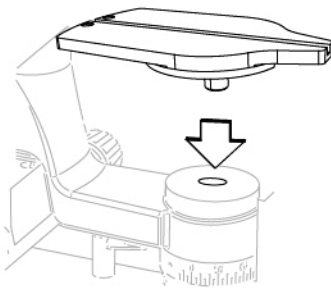

Fig 20 - How to place the tonometer support

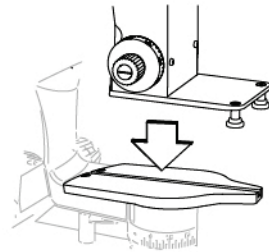

Fig 21 - How to place the tonometer F900

- 4 On the support guide of the tonometer there are two holes that allow the correct tonometer positioning to examine the patient's right or left eye.

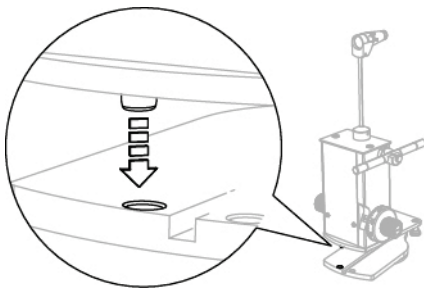

Fig 22 - Placement for right eye examination

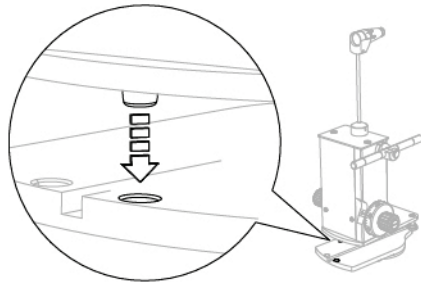

Fig 23 - Placement for left eye examination

4.4 HOW TO PREPARE THE SLIT LAMP (Z800)



The microscope has to be adjusted so that the measuring prism semicircles can be observed and clearly focused during the measurement.

- 1 Rotate the arm with measuring prism support on the observation axis of the microscope.
- 2 Make sure that the oculars of the slit lamp are adjusted to compensate the operator's potential ametropia.
- 3 Adjust the device light intensity.
- 4 Inserting the blue filter in the slit lamp.
- 5 Open the slit diaphragm completely. The angle between the light source and the microscope should be of 60° circa to obtain a clear image without reflexions.

4.5 HOW TO PREPARE THE SLIT LAMP (A900)



The microscope has to be adjusted so that the measuring prism semicircles can be observed and clearly focused during the measurement.

- 1 Rotate the connection support to place the measuring prism support on the observation axis of the microscope.
- 2 Make sure that the oculars of the slit lamp are adjusted to compensate the operator's potential ametropia.
- 3 Adjust the device light intensity.
- 4 Inserting the blue filter in the slit lamp.
- 5 Open the slit diaphragm completely. The angle between the light source and the microscope should be of 60° circa to obtain a clear image without reflexions.

4.6 HOW TO PREPARE THE SLIT LAMP (F900)



The microscope has to be adjusted so that the measuring prism semicircles can be observed and clearly focused during the measurement.

- 1 Make sure that the oculars of the slit lamp are adjusted to compensate the operator's potential ametropia.
- 2 Adjust the device light intensity.
- 3 Inserting the blue filter in the slit lamp.
- 4 Open the slit diaphragm completely. The angle between the light source and the microscope should be of 60° circa to obtain a clear image without reflexions.

4.7 HOW TO PLACE THE MEASURING PRISM



A wrong disinfection can cause cross-contamination between patients and operator and damages to the measuring prism.



Detergent or disinfectant products residuals can cause eye irritations.



It is forbidden to use damaged measuring prisms. The contact surface of the measuring prism must be inspected for contaminants or damage (scratches, cracks and sharp edges) prior to every use. Perform the check with a slit lamp microscope at 10/16 magnification.



Do not use the measuring prism beyond the date indicated on the production batch written on the package or after two years from the date of first use.



During the measuring prism positioning use disposable gloves.

4.7.1 HOW TO PLACE THE REUSABLE MEASURING PRISM



The reusable measuring prism has to be always disinfected prior to every use.

If you use a reusable measuring prism for the first time, clean it and disinfect it before use. The measuring prism is not provided in disinfected conditions.

Never take the prism from the part that will be in contact with the corneal surface.

- 1 Make sure that the reusable measuring prism has been properly disinfected and stored in a sterile container.
- 2 Carefully take the measuring prism. Take the measuring prism from the sides. Never touch the prism part that will be in contact with the corneal surface.
- 3 Check the absence of damages on the measuring prism surface.
- 4 Insert the measuring prism on the tonometer arm support.
- 5 Place the measuring knob on position 1.

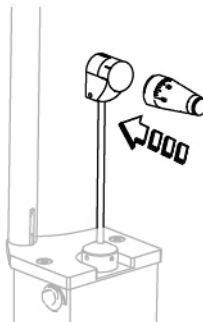

Fig 24 - How to insert the measuring prism on the support

4.7.2 HOW TO PLACE THE DISPOSABLE MEASURING PRISM



The disposable measuring prism has to be new and in its sterile package. The package has to be intact before opening it. Immediately dispose of the disposable prism after the exam.

- 1 The disposable measuring prism has to be new and sealed in its sterile package. The package has to be intact.
- 2 Carefully open the disposable measuring prism package. Take the measuring prism from the sides. Never touch the prism part that will be in contact with the corneal surface.
- 3 Check the absence of damages on the measuring prism surface.
- 4 Insert the measuring prism on the tonometer arm support.
- 5 Place the measuring knob on position 1.

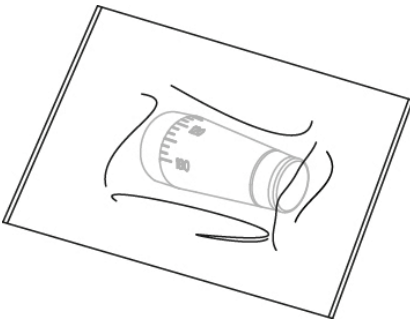

Fig 25 - Disposable measuring prism package

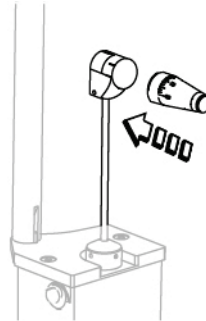

Fig 26 - How to insert the measuring prism on the support

4.8 HOW TO PREPARE THE PATIENT



If the patient is wearing contact lenses, make sure that they have been removed before applying the anesthetic drops.

- 1 Tell the patient to take a seat.
- 2 Apply a local anesthetic drop on the eye surface to be examined.
- 3 Apply sodium fluorescein 0,5% on the eye surface to be examined.
- 4 Ask the patient to put the chin on the chin cup and the forehead against the forehead rest.
- 5 Verify the correct eyes position respectively to the shooting channel.
- 6 Ask the patient to look towards the front and keep the eyes open during the exam. If necessary use the fixation target to help the patient to keep the eyes still.

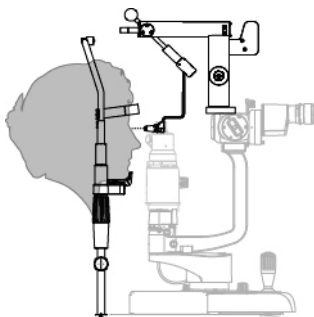

Fig 27 - Position of the tonometer Z800 (SL9800)

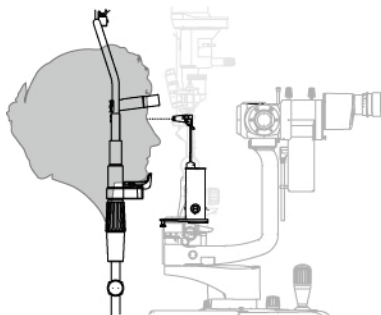

Fig 28 - Position of the tonometer F900 (SL9900)

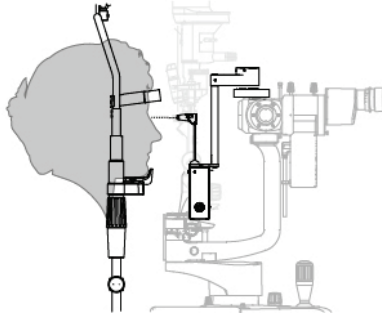

Fig 29 - Position of the tonometer A900 (SL9900)

4.9 HOW TO MEASURE THE INTRAOCULAR PRESSURE



Tell the patient to keep the eyes open during the exam.



The measurement time should be as short as possible.

- 1 Ask the patient to open and close the eyes for a few seconds, so that the tear film is evenly distributed on the corneal surface.
- 2 Choose the blue filter to activate the fluorescein.
- 3 Move forward the slit lamp until the measuring prism is into contact with the center of the cornea.
- 4 Place the graduated scale on the value 1.
- 5 Observing the applanated surface with the microscope you will see two semicircles of the same size. The two semicircles can have different sizes depending on the ocular pressure. When the tonometer is in the right position, the two semicircles have the same dimension.

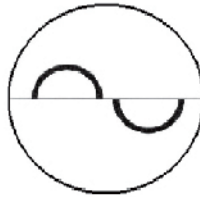

Fig 30 - Microscope observed image

- 6 Slowly turn the tonometer measurement knob until the semicircles will be perfectly aligned.

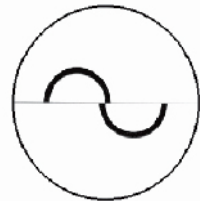

Fig 31 - Correct semicircles alignment

4.10 HOW TO MEASURE THE INTRAOCULAR PRESSURE IN ASTIGMATIC PATIENTS

In case of irregular cornea, measurements can be taken on any meridian.

In case of patients with astigmatism greater than 3 dioptres, the choice of the prism position considering the flatter meridian is significant to improve the measurement accuracy.

The principle of Goldmann tonometry says that every time that an area of 7.354mm² with 3.06 mm diameter from the center of the cornea is applanated, the real ocular pressure is measured.

The prism's semicircles are therefore reached sooner in the flatter meridian than in the steeper one. The problem can be overcome rotating the prism to 43°, on red sign positioned on the prism holder, in the respect of the flatter meridian.

Alternatively, a simple approach is the positioning of the prism in correspondence to the average of the two meridians, the flatter and steeper.

4.11 CORRECTING THE WRONG ACQUISITIONS

Observing the applanated surface with the microscope, the two semicircles should be of the same size and perfectly aligned.

If the two semicircles are in a wrong position, in what follows are described the possible causes and solutions to visualize the right position.

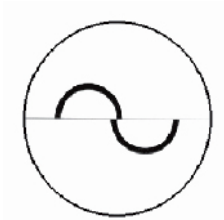
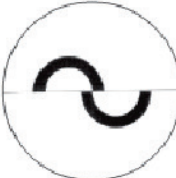
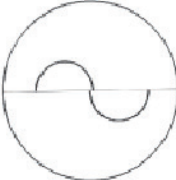
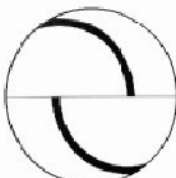

Fig 32 - Right semicircles position

Fluorescein semicircle too wide or too small.

Image	Cause	Solution
	<p>The image of the two semicircles is too wide. The intraocular pressure measurement might result higher than the real one.</p>	<p>Carefully clean the measuring prism before positioning it again.</p>
	<p>The image of the two semicircles is too small. The intraocular pressure measurement might result lower than the real one.</p>	<p>Carefully clean the measuring prism before positioning it again.</p>

The measuring prism does not touch the cornea or an excessive pressure has been applied.

Image	Cause	Solution
	<p>If the patient draws his/her head back slightly, irregular movements of the eye will happen. this will cause an unstable contact between measuring prism and eye.</p>	<p>Ask the patient to stay perfectly still and open the eyes better. Repeat the measurement.</p>

The two semicircles are not visualized correctly.

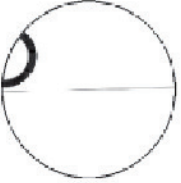
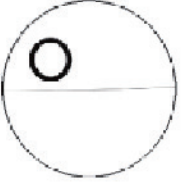
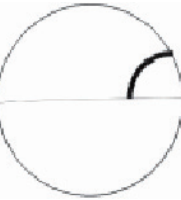
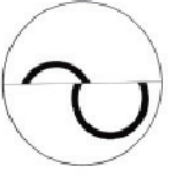
Image	Cause	Solution
	<p>Wrong the slit lamp position.</p>	<p>Adjust the slit lamp height and move it on the left with the joystick.</p>
		
	<p>The semicircles are too far to the right.</p>	<p>Move the slit lamp on the right with the joystick.</p>
	<p>The measurement might result way higher than the real one.</p>	<p>Adjust the slit lamp height. Repeat the measurement.</p>

The inner sides of the two semicircles are not aligned correctly.

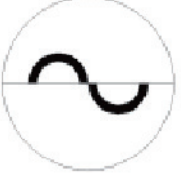
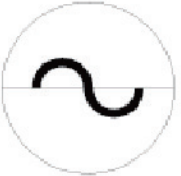
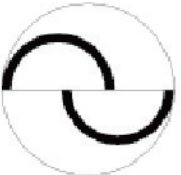
Image	Cause	Solution
	<p>The two semicircles are centered but the sides are not correctly aligned.</p>	<p>Increase the pressure by turning the measurement knob.</p>
	<p>The two semicircles are centered but the sides are not correctly aligned.</p>	<p>Increase the pressure by turning the measurement knob.</p>
	<p>The two semicircles are centered but the sides are not correctly aligned</p>	<p>Excessive applied pressure. Reduce the pressure by rotating the measurement knob until the two semicircles will be correctly aligned.</p>

4.12 HOW TO READ THE MEASURING SCALE

The measuring prism contact surface has a diameter of 7,0 mm. It is flat with round edges to avoid possible damages to the corneal surface.

By turning the measuring knob the pressure on the eye is increased until you obtain a continuous applanated and regular surface.

The intraocular pressure expressed in mmHg is calculated by multiplying the value indicated by the knob position times 10.

In the following table is indicated the relationship between the measuring knob position, the force and pressure in the applanated surface.

Position on the measuring knob	mN	kPa	mmHg
1	9,81	1,33	10
2	19,62	2,66	20
3	29,43	39,9	30
4	39,24	53,2	40
5	49,05	66,5	50
6	58,86	79,8	60
7	68,67	93,1	70
8	78,48	10,64	80

4.13 HOW TO REMOVE THE MEASURING PRISM



While removing the measuring prism use disposable gloves.

- 1 Carefully remove the measuring prism from the support.
- 2 If you used a reusable measuring prism, clean it as described in the paragraph **Measuring prism cleaning at page 45**
- 3 If you use a disposable measuring prism, dispose it immediately.

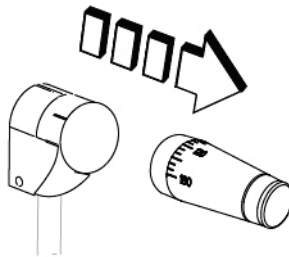

Fig 33 - Measuring prism removal

4.14 HOW TO REMOVE THE TONOMETER Z800 FROM THE SLIT LAMP

- 1 Rotate the arm and place it on the protection bracket in resting position.
- 2 Lift the tonometer too remove it from the support pivot.
- 3 Unscrew the screw and remove the support from the slit lamp.
- 4 Keep the device in a dry and safe place.

4.15 HOW TO REMOVE THE TONOMETER A900 FROM THE SLIT LAMP

- 1 Rotate the arm on the right. The tonometer can be left on the slit lamp.
- 2 Alternatively, lift the tonometer too release it from the support pivot.
- 3 Unscrew the screw and remove the support from the slit lamp.
- 4 Keep the device in a dry and safe place.

4.16 HOW TO REMOVE THE TONOMETER F900 FROM THE SLIT LAMP

- 1 Lift the tonometer too remove the support from the guide.
- 2 Remove the support guide from the slit lamp.
- 3 Keep the device in a dry and safe place.

5 ORDINARY MAINTENANCE

5.1 SAFETY WARNINGS



CAUTION

The device does not contain any piece that requires the user's intervention. Do not dismantle any part of the device.



CAUTION

The reusable measuring prism is not provided in disinfected conditions. Hence, it has to be always cleaned and disinfected before use.

Carefully follow the instructions for the cleaning and disinfection of the measuring prism described in this manual.



CAUTION

Due to the large number of variables to be considered (number of patients, treatment, type and concentration of the disinfectant used) it is impossible to provide exact information on how long a measuring prism can be used. Do not use the measuring prism beyond two years from the date written on the package in conformity with what is written in this manual. Damaged prisms must be immediately replaced.



The measuring prism shall not be disinfected with other instruments or medical devices.



It is forbidden to disinfect and reuse the disposable prisms.



It is forbidden to carry out any maintenance operation on the device that is not recalled in the instructions for use.



In case of operational faults or malfunctions or for every maintenance operation not mentioned in the instructions for use, there is the obligation to address an authorized technical assistance center of the device Manufacturer.



It is forbidden to clean the disposable measuring prisms. The cleaning procedure has to be carried out only reusable measuring prisms.



It is forbidden to use the following cleaning procedures. They could damage the measuring prism.

- Use of alcohol
- Use of acetone
- Use of UVA radiations
- Soaking the measuring prism in a fluid for more than 60 minutes.
- Exposition to temperatures higher than 60°
- Different disinfection procedures than the one described in these instructions for use.

5.2 DEVICE CLEANING

Clean the external parts of the device using a damp non-abrasive cloth to avoid damaging the material.



CAUTION

Danger of material damages. Do not use solvents or diluent to clean the device.

5.3 MEASURING PRISM CLEANING



While cleaning the measuring prism use disposable gloves.

- 1 Carefully remove the measuring prism from the tonometer support.
- 2 Wash it with cold running water for 30-60 seconds. If necessary, use a neutral pH detergent (without irritating agents) and a disposable cloth, soft which does not release lint. Always dab in the same direction.
- 3 Rinse the measuring prism. Make sure that there is no presence of detergent or contaminants. If there is still some dirt repeat point 2.

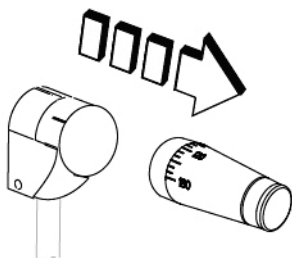

Fig 34 - Measuring prism removal

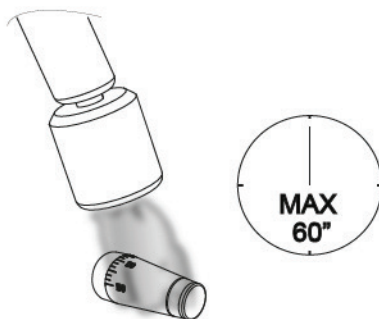

Fig 35 - Measuring prism washing

- 4 Dry the measuring prism with a disposable cloth, soft which does not release lint.
- 5 Check the absence of dirt on the measuring prism integrity.
- 6 Place the measuring prism in a clean and dry container.

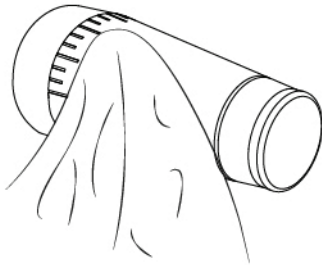

Fig 36 - Drying the measuring prism

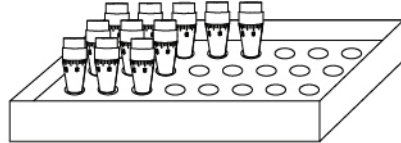

Fig 37 - Measuring prisms container

5.3.1 MEASURING PRISM DISINFECTION



While disinfecting the measuring prism use disposable gloves.

- 1 Fill a clean and disinfected container with the disinfectant solution. The disinfectant solution shall cover the measuring prisms completely.
- 2 Place the measuring prisms in the container.
- 3 The measuring prisms shall not be on top of each other.
- 4 The measuring prisms shall be completely immersed in the disinfectant solution
- 5 Let the disinfectant have its effect following the instructions of the disinfectant solution Producer.

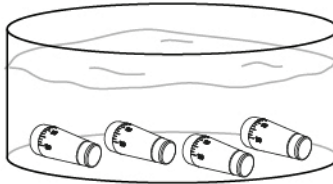

Fig 38 - Soaking the measuring prism in the container

- 6 After the indicated time has passed remove the measuring prisms from the container and let them drip for a few seconds.
- 7 Place the measuring prism in another clean and disinfected container.
- 8 Rinse the measuring prisms under running cold water for min 10 minutes, max 15 minutes.
- 9 Remove the measuring prisms from the container.

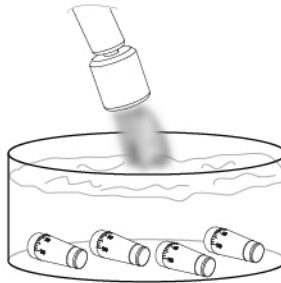

Fig 39 - Rinsing the measuring prism in the container

- 10 Dry the measuring prism one by one with a sterile disposable cloth.
- 11 Store the clean and disinfected measuring prisms in a hermetic and sterile container.

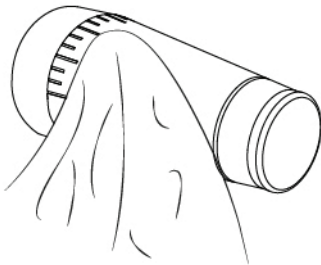

Fig 40 - Drying the measuring prism

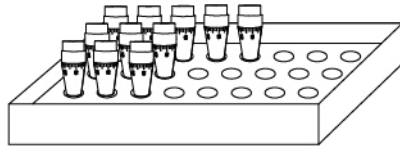

Fig 41 - Measuring prisms containers

For the suitable disinfectants list for cleaning and disinfection of measuring prisms see the Report published by the American Academy of Ophthalmology at this page:

[https://www.aaojournal.org/article/S0161-6420\(17\)31677-9/pdf](https://www.aaojournal.org/article/S0161-6420(17)31677-9/pdf)

5.4 TONOMETER FUNCTIONING CHECK



CAUTION

If the device is outside from the indicated calibration tolerances, contact the Technical Service for reparation and calibration.



To check the device correct functioning you need to use the specific functioning control accessory.

- 1 Place the functioning control accessory on the device.
- 2 The functioning control accessory has 5 markings on its body. The markings correspond to the values indicated on the measuring knob: 0 (central), 2, 6 (ends). The functioning control accessory longer end shall be placed facing the examiner.

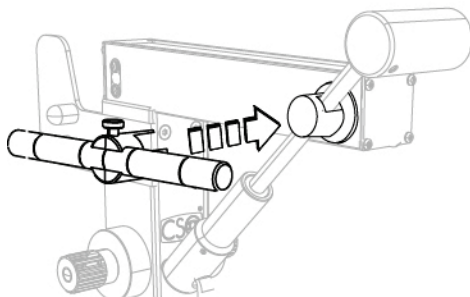

Fig 42 - How to place the functioning control accessory on the tonometer Z800

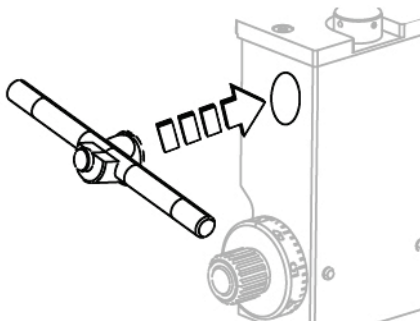

Fig 43 - How to place the functioning control accessory on the tonometer A900 and F900

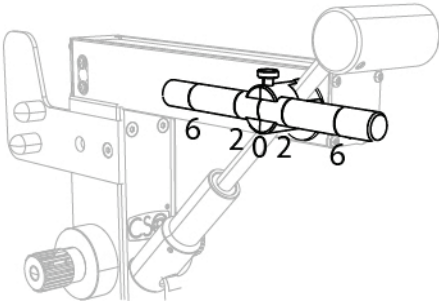

Fig 44 - Marking on the functioning control accessory on the tonometer (Z800)

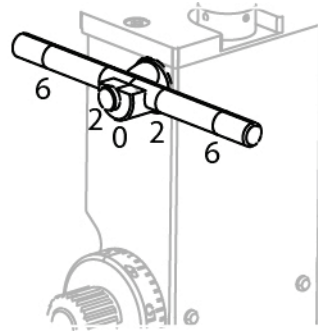

Fig 45 - Marking on the functioning control accessory on the tonometer (A900 and F900)

5.4.1 FUNCTIONING CONTROL WITH MEASURING KNOB ON 0

- 1 Position the functioning control accessory in position 0 (central) and the measuring knob on the corresponding value 0.
- 2 Turn the measuring knob on the value - 0,05 (measure equivalent to the width of the calibration sign on the measuring knob).
- 3 The arm should be displaced in stop position facing the examiner.
- 4 Turn the measuring knob on the value + 0,05 (measure equivalent to the width of the calibration sign on the measuring knob).
- 5 The arm should be displaced in stop position facing the patient.

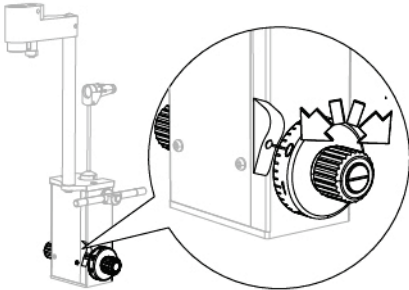

Fig 46 -Tonometer A900 measuring knob

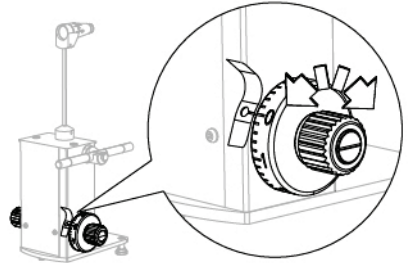

Fig 47 -Tonometer F900 measuring knob

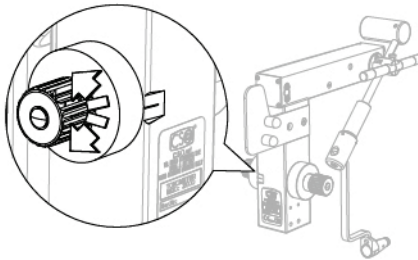

Fig 48 -Tonometer Z800 measuring knob

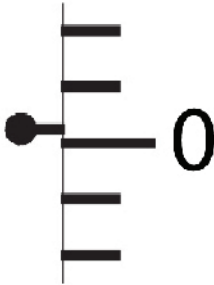

Fig 49 - Position - 0,05

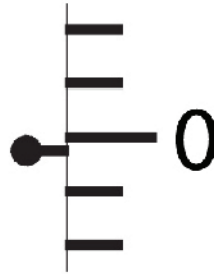

Fig 50 - Position + 0,05

5.4.2 FUNCTIONING CONTROL WITH MEASURING KNOB ON 2



CAUTION

This is the most important checking procedure. The ocular pressure in this area is highly significant. This check should be carried out at least twice a year.

- 1 Position the functioning control accessory in position 2 (first lateral marking) and the measuring knob on the corresponding value 2.
- 2 Turn the measuring knob on the value + 1,95 (measure equivalent to the width of the calibration sign on the measuring knob).
- 3 The arm should be displaced in stop position facing the examiner.
- 4 Turn the measuring knob on the value + 2,05 (measure equivalent to the width of the calibration sign on the measuring knob).
- 5 The arm should be displaced in stop position facing the patient.

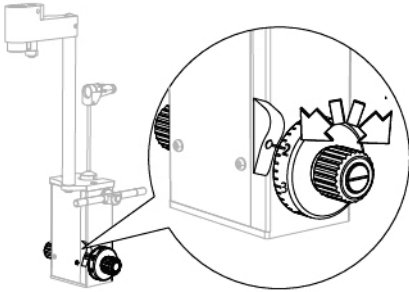

Fig 51 -Tonometer A900 measuring knob

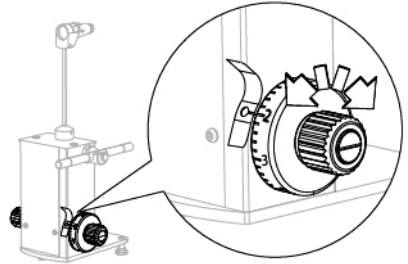

Fig 52 -Tonometer F900 measuring knob

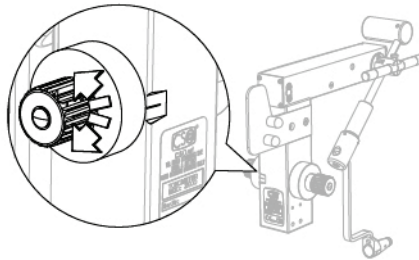

Fig 53 -Tonometer Z800 measuring knob

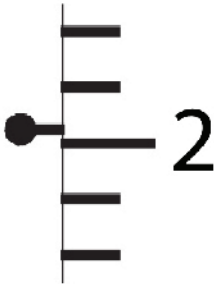

Fig 54 - Position + 1,95

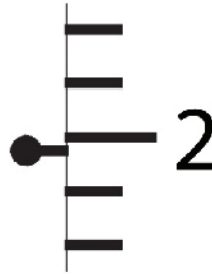

Fig 55 - Position + 2,05

5.4.3 FUNCTIONING CONTROL WITH MEASURING KNOB ON 6

- 1 Position the functioning control accessory in position 6 (second lateral marking) and the measuring knob on the corresponding value 6.
- 2 Turn the measuring knob on the value + 5,95 (measure equivalent to the width of the calibration sign on the measuring knob).
- 3 The arm should be displaced in stop position facing the examiner.
- 4 Turn the measuring knob on the value + 6,05 (measure equivalent to the width of the calibration sign on the measuring knob).
- 5 The arm should be displaced in stop position facing the patient.

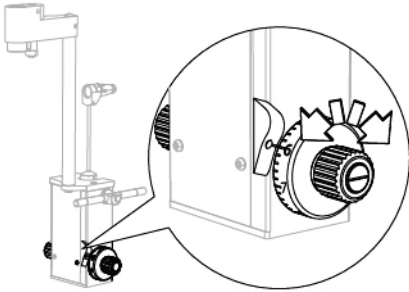

Fig 56 -Tonometer A900 measuring knob

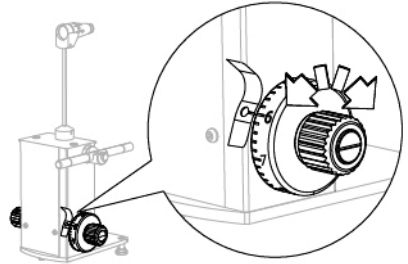

Fig 57 -Tonometer F900 measuring knob

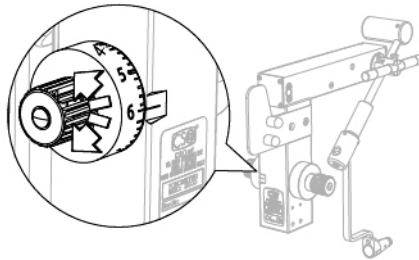

Fig 58 -Tonometer Z800 measuring knob

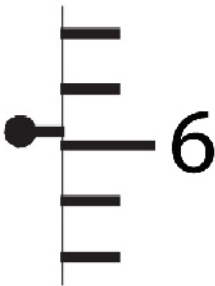

Fig 59 - Position + 5,95

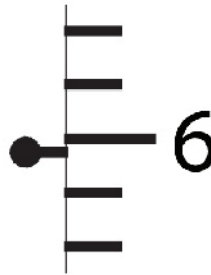

Fig 60 - Position + 6,05

5.5 SPARE PARTS AND ACCESSORIES LIST

Tonometer

Code	Description
10200100	Applanation tonometer Z800
10200200	Applanation tonometer F900
10200220	Applanation tonometer A900

Support for tonometer F900

Code	Description
100203112	Support for tonometer F900. Only for lamp SL9900

Support for tonometer A900

Code	Description
100203100	Installation support for microscopes 2x - 3x - 5x galieian old version
100250303	Installation support for microscopes 2x - 5x galieian and internal zoom new version
100212609	Installation support on zoom microscopes

Support for tonometer Z800

Code	Description
100203101	Installation support for microscopes 2x - 3x - 5x galieian old version
100203102	Installation support (dominant left eye) for microscopes 2x - 3x - 5x galieian old version
100250302	Installation support for microscopes 2x - 5x galieian and internal zoom new version
100212608	Installation support on zoom microscopes

Measuring prism

Code	Description
102001110	Reusable measuring prism for tonometer.
102003200	Disposable measuring prism for tonometer (100 units package).

5.6 TROUBLESHOOTING

Inconvenient	Cause	Solution	Note
The device is not stable during the measurement or during its positioning.	The blocking screws of the support are loosened.	Fasten the screw of the device support with a suitable tool.	The device might have been hit. If necessary, contact the Technical Service for the device calibration.
Wrong vertical alignment of the device in respect to the microscope.	The fastening screws of the tonometer are loosened (Z800).	Align the device with the microscope. Fasten the device blocking screws with a suitable tool.	The device might have been hit. If necessary, contact the Technical Service for the device calibration.
Wrong horizontal alignment of the device in respect to the microscope.	The fastening screws of the tonometer are loosened (Z800).	Align the device with the microscope. Fasten the device blocking screws with a suitable tool.	The device might have been hit. If necessary, contact the Technical Service for the device calibration.
Wrong horizontal and vertical alignment of the device in respect to the microscope.	The arm is bent.	Contact the Technical Assistance Center.	

Inconvenient	Cause	Solution	Note
The measuring prism does not correctly blocked in its seat.	The measuring prism could be smaller than the expected ones.	Tighten the blocking flaps on the measuring prism support.	Some measuring prisms could be smaller than the expected ones. Use CSO spare parts only.
The measuring prism does not fit correctly in its seat.	The measuring prism could be bigger than the expected ones.	Adjust the blocking flaps on the measuring prism support so that it fits correctly.	Some measuring prisms could be bigger than the expected ones. Use CSO spare parts only.
The measuring prism does not allow a clear visualization of the applanation.	Take the prism material is spoiled.	Replace the measuring prism with a new one.	Use CSO spare parts only.
The applanation is not correctly visualized during the measurement.	The slit lamp illuminator light is not in the correct position or it is off.	Place the slit lamp illuminator light in the correct position. Turn on the light and adjust its intensity.	Read the indications given in the instructions for use for the slit lamp.

Inconvenient	Cause	Solution	Note
The applanation is not correctly visualized during the measurement.	The tonometer is not placed correctly in respect of the examined eye (F900).	Correctly place the tonometer in respect of the examined eye.	Read the indications given in the instructions for use.
The applanation is not correctly visualized during the measurement.	Missing fluorescein instillation in the examined eye.	Apply sodium fluorescein as indicated in the instructions for use.	Always use products compliant with the current legislation.
The applanation is not correctly visualized during the measurement.	The arm is bent.	Contact the Technical Assistance Center.	The device might have been hit.



COSTRUZIONE STRUMENTI OFTALMICI

Via degli Stagnacci 12/E | 50018 Scandicci (FI) | ITALY
phone: +39 055 722191 | fax: +39 055 721557

cso@csoitalia.it | www.csoitalia.it