

C-Digit[®]

Blot Scanner

User Guide



LI-COR[®]

CE Marking

This product (model number 3600) is a CE-marked product. For conformity information, contact LI-COR Support at <http://www.licor.com/biotechsupport>. Outside of the U.S., contact your local sales office or distributor.

C-数字 (型号3600) 印迹扫描器 C-DiGit (Model 3600) Blot Scanner						
部件名称 Part Name	有毒有害物质或元素 Toxic and Hazardous Substances or Elements					
	铅 (PB)	汞 (Hg)	镉 (Cd)	六价铬 (Cr(VI))	多溴联苯 (PBB)	多溴二苯醚 (PBDE)
印刷电路板 (PCBs)	X	○	○	○	○	○
机电配件 (Electromechanical Parts)	○	○	○	○	○	○
光学 (Optics)	○	○	○	○	○	○
电缆和电线 (Cables and Wires)	○	○	○	○	○	○
金属部件 (Metal Parts)	○	○	○	○	○	○
塑料零件 (Plastic Parts)	○	○	○	○	○	○

本表格依据 SJ/T 11364 的规定编制

○ = 表示该有害物质在该部件所有均质材料中的含量均在 GB/T 26572 规定的限量要求以下

indicates that the content of the toxic and hazardous substance in all the Homogeneous Materials of the part is below the concentration limit requirement as described in GB/T 26572

X = 表示该有害物质至少在该部件的某一均质材料中的含量超出 GB/T 26572 规定的限量要求

indicates that the content of the toxic and hazardous substance in at least one Homogeneous Material of the part exceeds the concentration limit requirement as described in GB/T 26572



CDG-999999 3600 1605



Manufacturing Date Code: 生产日期代码

16 = 2016
05 = May

16 = 2016年
05 = 月

Notes on Safety

LI-COR products have been designed to be safe when operated in the manner described in this manual. The safety of this product cannot be guaranteed if the product is used in any other way than is specified in this manual. The C-DiGit® Blot Scanner is intended to be used by qualified personnel. Read this entire manual before using the C-DiGit Blot Scanner.

Equipment Markings:



The product is marked with this symbol when it is necessary for you to refer to the manual or accompanying documents in order to protect against damage to the product.



The product is marked with this symbol when a hazardous voltage may be present.

Manual Markings:

- WARNING** **Warnings** must be followed carefully to avoid bodily injury.
- CAUTION** **Cautions** must be observed to avoid damaging your equipment.
- NOTE** **Notes** contain additional information and useful tips.
- IMPORTANT** **Information of importance** to prevent procedural mistakes in the operation of the equipment or related software. Failure to comply may result in a poor experimental outcome but will not cause bodily injury or equipment damage.

Federal Communications Commission Radio Frequency Interference Statement

WARNING: This equipment generates, uses, and can radiate radio frequency energy and if not installed in accordance with the instruction manual, may cause interference to radio communications. It has been tested and found to comply with the limits for a Class A computing device pursuant to Subpart J of Part 15 of FCC rules, which are designed to provide a reasonable protection against such interference when operated in a commercial environment. Operation of this equipment in a residential area is likely to cause interference in which case the user, at his own expense, will be required to take whatever measures may be required to correct the interference.

Notice

The information contained in this document is subject to change without notice. LI-COR MAKES NO WARRANTY OF ANY KIND WITH REGARD TO THIS MATERIAL, INCLUDING, BUT NOT LIMITED TO THE IMPLIED WARRANTIES OF MERCHANTABILITY AND FITNESS FOR A PARTICULAR PURPOSE. LI-COR shall not be liable for errors contained herein or for incidental or consequential damages in connection with the furnishing, performance, or use of this material.

This document contains proprietary information that is protected by copyright. All rights are reserved. No part of this document may be photocopied, reproduced, or translated to another language without prior written consent of LI-COR, Inc.

Printing History

Publication Number 977-19726

1st Printing January, 2013

2nd Printing February, 2014

Revised: June 2021

LI-COR, C-DiGit, Image Studio, and WesternSure are trademarks or registered trademarks of LI-COR, Inc in the United States and other countries. Macintosh, Mac and OS X are trademarks of Apple, Inc. Third party trademarks, trade names, and product names may be trademarks or registered trademarks of their respective owners. You may not remove or alter any trademark, trade names, product names, logo, copyright or other proprietary notices, legends, symbols, or labels. This End- User License Agreement does not authorize you to use LI-COR's or its licensors' names or any of their respective trademarks.

LI-COR is an ISO 9001:2015 registered company. Copyright 2021 LI-COR, Inc. All rights reserved. Specifications subject to change. The C-DiGit Blot Scanner is covered by U.S. patents, foreign equivalents, and patents pending.



Global Headquarters

4647 Superior Street • Lincoln, NE 68504

Toll free: 800-645-4267 • Fax: +1-402-467-0819 • biosales@licor.com • licor.com/bio

Regional Offices

LI-COR Biosciences GmbH

Siemensstraße 25A • 61352 Bad Homburg • Germany

Phone: +49 (0) 6172 17 17 771 • Fax: +49 (0) 6172 17 17 799 • bio-eu@licor.com

LI-COR Biosciences UK Ltd.

St. John's Innovation Centre • Cowley Road

Cambridge • CB4 0WS

United Kingdom • Phone: +44 (0) 1223 422104 • Fax: +44 (0) 1223 422105 • bio-eu@licor.com

LI-COR Biotechnology Distributor Network: www.licor.com/bio/distributors

Table of Contents

Chapter 1: Introduction

About C-DiGit Blot Scanner	9
What's in the Box	10
Placement in the Laboratory	10
Ambient Laboratory Conditions	10
Space Requirements	10
Safety Considerations	11
Chemical Safety	11
Electrical Considerations	11
Scanning Surface and Rear Safety Labels	11
Fuse Replacement	11
External Panels and Controls	12
Front Panel	12
Back Panel	13
Scanning Surface	13
Scanning Surface Safety	13
Sample Placement	14

Chapter 2: Quick Start Tutorial

Chapter 3: Scanning Membranes

Placing the Membrane on the C-DiGit Blot Scanner Scanning Surface	27
Using Blocking Buffer	28
Primary and Secondary Antibodies	29
Washing Buffer	29
Substrates	29
Imaging	30

Chapter 4: Computer Connections & Networking

Computer Connections and Networking	34
Direct Connection Via USB Cable	34
Direct Connection Via Ethernet Cable	34

Chapter 5: Maintenance & Troubleshooting

Maintenance	35
Troubleshooting –Hardware Problems	35
System Requirements	35
Cannot Connect to C-DiGit Blot Scanner	35
USB Cabling Problems	36
Front Panel Warning Light Indicates an Error	36
Resetting the Instrument	37
Troubleshooting –Chemistry Problems	37
High Background Due to Substrate	37
High Background from Wrapping the Blot in Plastic Wrap	37
Low Signal	38
Troubleshooting –Image Studio™ Software Problems	38
Obtaining Technical Support	39
Exporting Image Studio Software Log Files	39

Chapter 6: Specifications

Chapter 7: Training Video Links

Chapter 8: Embedded Firmware Source Code

Chapter 1: Introduction

C-DiGit® Blot
Scanner

About C-DiGit Blot Scanner

The C-DiGit Blot Scanner is designed to image membranes for chemiluminescent Western blot analysis using digital methods, eliminating the need for traditional exposure to film. Before image acquisition is started, a membrane is placed on the scanning surface and the lid is closed. Image acquisition is started via Image Studio™ Software (see the Image Studio Software help for details).



The C-DiGit has one detection channel that detects visible wavelength emissions from chemiluminescent substrates.

The C-DiGit Blot Scanner is a networkable device, and can be connected directly to a computer (Macintosh® or PC) via Ethernet or USB cables.



[Click here to watch an introductory video about the C-DiGit Blot Scanner.](#)

What's in the Box

In addition to the C-DiGit Blot Scanner, you will find the items shown below* (l-r): 1) Ethernet and 2) USB cables, 3) a power supply with interchangeable plugs, 4) a C-DiGit Target image, and 5) Image Studio and Resource CDs.



The C-DiGit Target is a photosensitive card used to verify that your C-DiGit Blot Scanner is functioning properly; the card is briefly exposed to room light and then imaged on the instrument. If the acquired pattern matches the target image, the C-DiGit Blot Scanner is functioning as it should, and is ready to image your sample. Instructions for using the Target are given below in the *Quick Start Tutorial* on page 15. The Target should be stored in the blue envelope when not in use.

Placement in the Laboratory

The C-DiGit Blot Scanner weighs approximately 2.18 kg (4.8 lbs.). The instrument should be placed on a level surface that is at a workable height for the user.

Ambient Laboratory Conditions

Place the C-DiGit Blot Scanner away from external heat sources (furnaces, windows, etc.). Additional heating can cause high temperatures within the enclosure. Place the instrument away from sinks or other sources of water that pose a shock hazard. Recommended operating conditions are 15-30 °C and a dew point no greater than 25 °C to prevent condensation on the instrument.

Space Requirements

The C-DiGit Blot Scanner requires an area 27.94 cm L (11.0") x 22.23 cm W (8.75") x 7.3 cm H (2.875", lid closed), or 31.12 cm, (12.25", lid open).

*Use only the provided cables with the C-DiGit Blot Scanner.

Safety Considerations

Chemical Safety

LI-COR Biosciences recommends that all chemicals be handled carefully, and that safe laboratory procedures be followed at all times. Be aware of the hazards associated with any chemical before you begin work.



WARNING: The C-DiGit Blot Scanner should not be used with any radioactive materials.

Electrical Considerations

The C-DiGit Blot Scanner includes a power supply that plugs into a wall outlet, with an output that plugs into the C-DiGit instrument.

Do not locate the C-DiGit Blot Scanner where the power supply cord will be walked on or exposed to water or chemical spills.

The C-DiGit Blot Scanner draws a maximum of 1 ampere at 120V (see *Specifications* on page 41). If a power strip or surge protector is used, make sure the total of the ampere ratings on the instruments plugged into the extension cord does not exceed the extension cord ampere rating. Also make sure the total amperage of instruments plugged into the wall outlet does not exceed the amperage capacity for the outlet (usually 15 or 20 amperes in the United States).

Scanning Surface and Rear Safety Labels

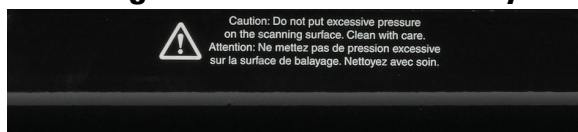

Figure 3-1. Scanning surface instrument safety label.



Figure 3-2. Rear instrument safety label.

Fuse Replacement

There are no user replaceable fuses in this instrument.

External Panels and Controls

Front Panel



Figure 3-3. Front panel features and controls of the C-DiGit Blot Scanner.



Power Indicator: While the C-DiGit Blot Scanner is performing its startup or shutdown procedure, the blue power indicator light on the instrument front panel blinks. When the blue indicator light is continuously on, the instrument is ready for operation.



Image Acquisition Indicator: This green indicator light blinks during image acquisition and is continuously on at other times, as long as communication with the Image Studio software is maintained. The indicator light is off only when communication is lost, the Image Studio software is closed, or the instrument is powered off.



Error Indicator: The red error indicator light illuminates when a process could not be completed. See the Status Message History dialog in the Image Studio software and *Maintenance & Troubleshooting* on page 35 for details about the error condition.

Back Panel

The C-DiGit back panel has the instrument ON/OFF switch and connectors for the USB and Ethernet cables and the power supply.



Scanning Surface

The scanning surface is accessed by opening the lid on the C-DiGit Blot Scanner (Figure 3-4).



Figure 3-4. The imaging surface is designed to scan a single membrane up to 10 cm x 8.5 cm.

Scanning Surface Safety

Be careful not to get your fingers caught between the C-DiGit instrument lid and the base of the scanning surface when the lid is closed. Do not put excessive pressure on the scanning surface. Clean

the scanning surface with 100% methanol, then water. CAUTION: DO NOT use acetone to clean the imaging surface.

Sample Placement

The C-DiGit Blot Scanner Imaging Surface has a clear window that delineates the edges of the C-DiGit Blot Scanner scanning surface. Membranes up to 10 cm x 8.5 cm placed within these markers will be fully imaged. Membranes can be placed anywhere within the imaging area to be scanned.

Membranes should be placed sample side down with the top toward the back of the instrument.

Tips for handling and imaging membranes are given in *Scanning Membranes* on page 27.

Chapter 2: Quick Start Tutorial

The Quick Start Tutorial Guide included with the C-DiGit Blot Scanner is intended as a quick verification tool to ensure that the C-DiGit is working properly, before you proceed to scan your own membranes. The Tutorial Guide is reproduced in this section, with some additional detail.

1) Unpack C-DiGit

In addition to the C-DiGit Blot Scanner, you will find the items shown below (l-r): 1) Ethernet and 2) USB cables, 3) a power supply with interchangeable plugs, 4) a C-DiGit Target, and 5) Image Studio and Resource CDs.



The USB cable is the default method used to connect to the C-DiGit Blot Scanner; the Ethernet cable is used for alternative connection methods described in *Computer Connections & Networking* on page 33.

2) Place C-DiGit in the Lab

Place the C-DiGit Blot Scanner away from heat sources (furnaces, windows, etc.) and out of direct sunlight.

3) Install Image Studio Software

Insert the Image Studio DiGits CD, and follow the instructions below to install the Image Studio software. Note that you should make sure that your user account has administrator rights on the computer.



[Click here to watch a video that describes the requirements for Image Studio.](#)

Macintosh Users

Note: Compatible with OS X 10.9 (Mavericks) or 10.10 (Yosemite).

- a. Place installation CD into drive.
- b. If installation does not start immediately, browse the Desktop and double-click on MacImageStudioDigits_5.x.x.dmg.
- c. Click Agree to accept the license agreement.
- d. To install, drag the Image Studio icon into the Applications folder.



[Click here to watch a video that demonstrates how to install Image Studio on a Macintosh computer.](#)

PC Users

Note: Compatible with Windows® 7, 8, and 8.1.

- a. Place installation CD into drive.
- b. If installation does not start immediately, browse to the CD or Desktop and double-click on Win_Image Studio Digits_5.x.x.exe.
- c. Click Agree to accept the license agreement.
- d. Follow the instructions to install the Image Studio software.



[Click here to watch a video that demonstrates how to install Image Studio Software on a Windows-based computer.](#)

4) Remove warning label from the back panel

Remove the yellow warning label on the C-DiGit Blot Scanner back panel (below).

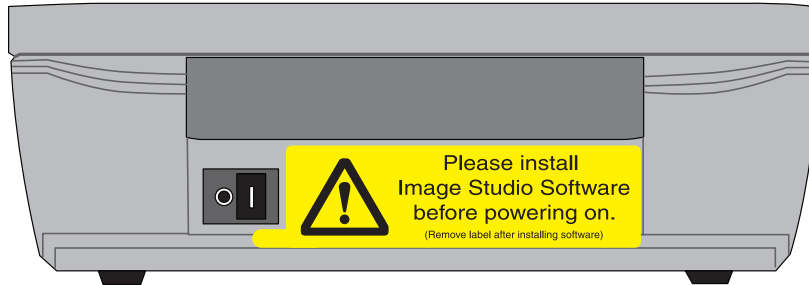

5) Install the Power Supply Plug

There are two power supplies available for use with the C-DiGit; you will have received either the Cincon (p/n 591-13058) or SL Power Electronics (p/n 591-19495) power supply. Each of these power supplies is a universal 100-240VAC input, 12VDC power output supply with interchangeable AC plugs for use in North America and Japan, Australia, Europe, and the United Kingdom. Install the appropriate plug on the power supply as shown below. NOTE: The SL Power Electronics supply has the North American/Japanese plug pre-installed. For use in other countries, remove this plug and replace with the appropriate plug.

Cincon Power Supply

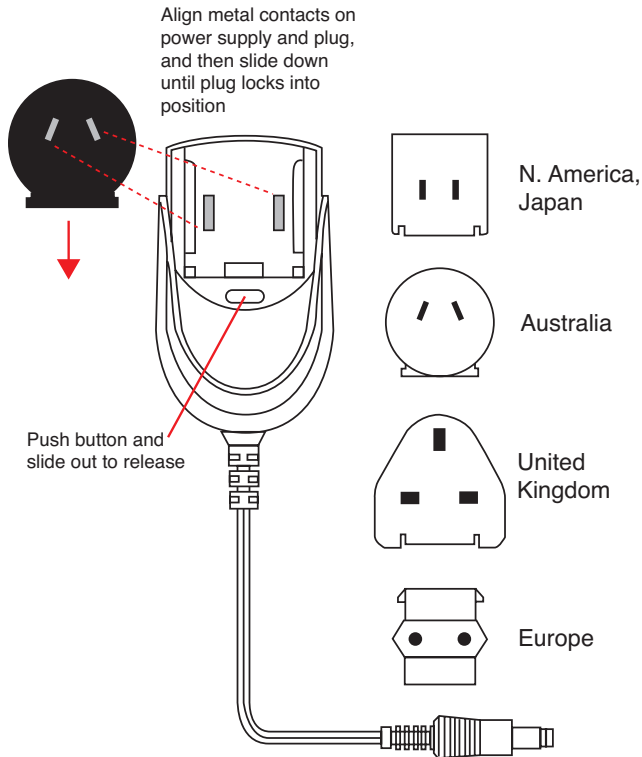

SL Power Electronics Power Supply

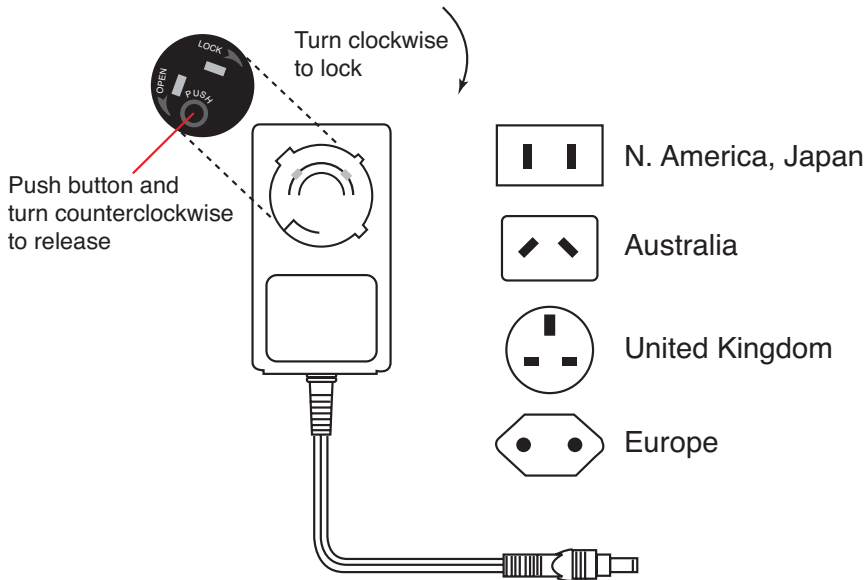

6) Connect the USB and Power Cables

Plug the power supply into the wall outlet, and plug the power cord into the receptacle on the C-DiGit back panel (below). Connect the flat (Type A) connector on the USB cable to your computer, and the square (Type B) connector to the C-DiGit Blot Scanner back panel at the connector labeled 'USB'.

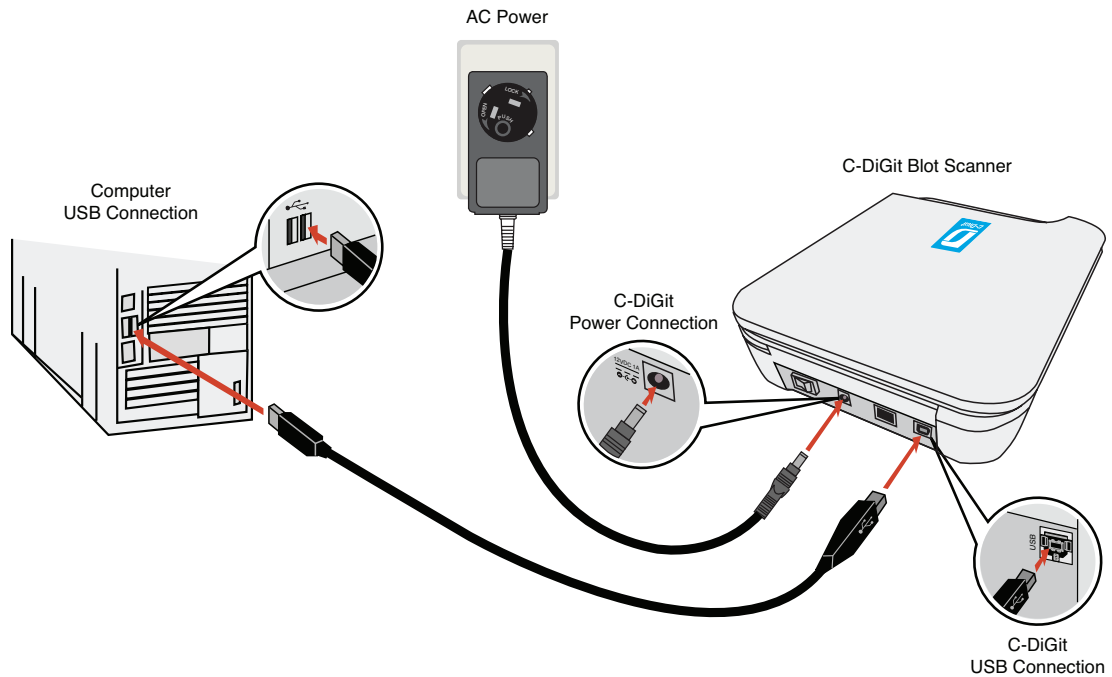

7) Turn on C-DiGit Blot Scanner

Power C-DiGit Blot Scanner on with the power switch on the back panel. The blue power light on the instrument front panel (below) illuminates and blinks when the instrument is first powered on, and stops blinking when the instrument has fully started up and is ready to use.



8) Wait While USB Drivers Install

When C-DiGit is powered on and connected to the computer for the first time, drivers are automatically installed on the computer. *Allow up to 5 minutes for the drivers to install before starting the Image Studio software in Step 9 below.* **NOTE:** You may have to dismiss any Windows® 'Found New Hardware' messages.

9) Start Image Studio

Double-click the Image Studio icon (below) on the desktop to start Image Studio.



10) Create a New Work Area Folder

The first time you start the software you will need to create the first Work Area. The Work Area is a folder on the hard drive or network where the images, analyzes and settings are stored.



[Click here to watch a video that demonstrates how to create a Work Area Folder.](#)

PC: Click **Create New...** in the Set Active Work Area dialog box to browse to a folder on the hard drive or network to use as the Work Area.

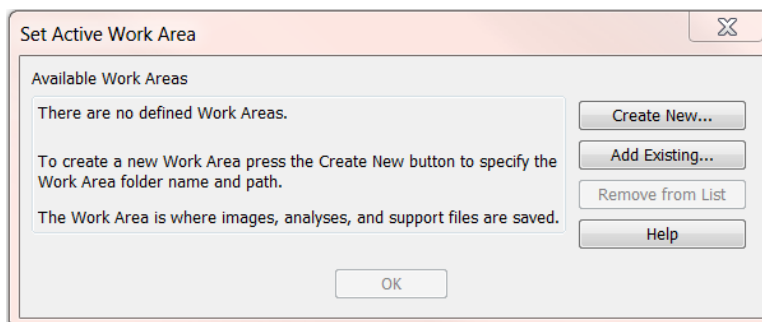

Navigate to the where the folder will reside, and name the folder; this folder will now appear in the Available Work Areas window each time the software is opened. Click Save.

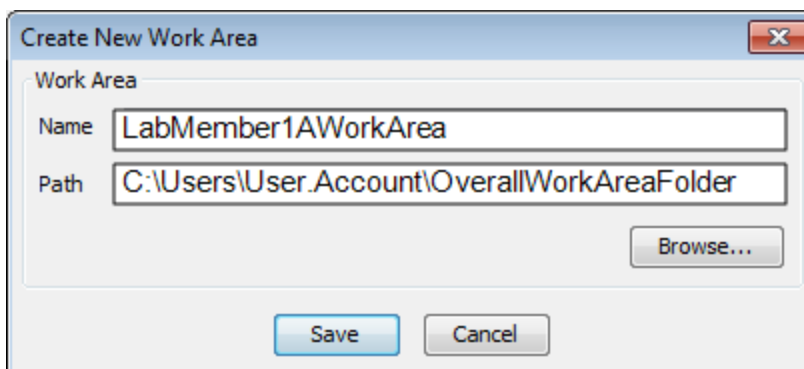

Mac: Click **Create New**. Navigate to where the folder will reside, name the folder, and click Save.

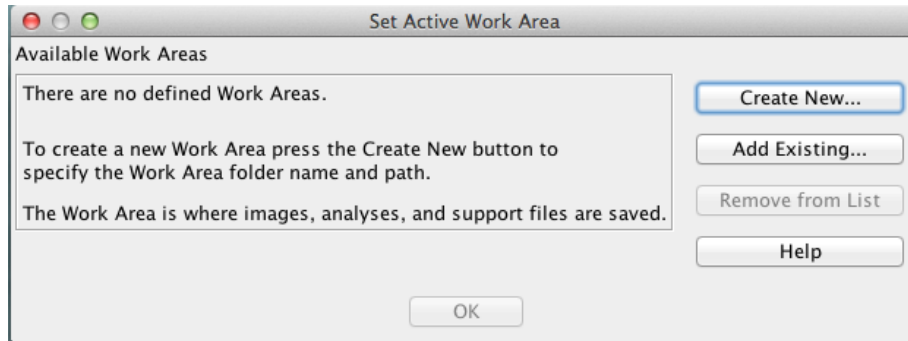

To remove a Work Area from the window, select it and click Remove from List. Removing the folder from the window does not delete the folder or its contents; it simply makes it unavailable in the Work Area list.

Note: Each user should create their own Work Area, as previous settings for the instrument, analysis, image display, etc. from the last session will be applied to the next session in the same Work Area.

11) Connect to C-DiGit Blot Scanner

If there is only one C-DiGit Blot Scanner detected by the computer, it will connect automatically; if there are multiple C-DiGit Blot Scanners detected, you can choose the desired C-DiGit Blot Scanner from a list of available instruments (below, listed by serial number).

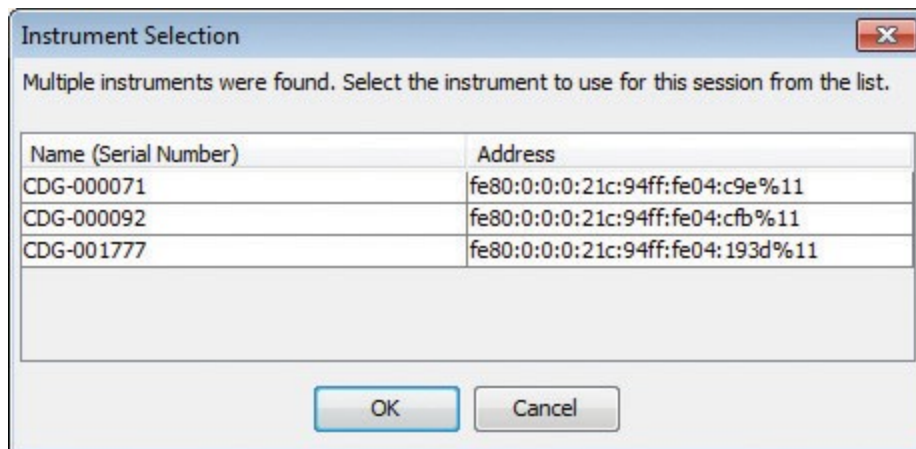

NOTE: You can find the serial number on a label on the underside of the instrument.

When a connection is established, the green indicator light (below) will illuminate on the instrument front panel, and the Status panel in the Image Studio window will display 'Ready'.

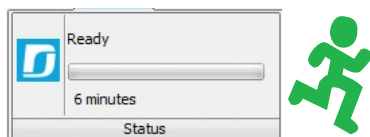

NOTE: C-DiGit Blot Scanner uses IPv6 and IPv4 Link-Local Addressing to automatically create an IP network without any user configuration or additional servers. If you experience connection problems, be sure that IPv6 is enabled on the computer.

12) Expose the C-DiGit Blot Scanner Target

Open the Target envelope and expose the side of the Target with the gray background to room light for 30 seconds. Place the Target face down (gray background) on the C-DiGit Blot Scanner scanning surface.

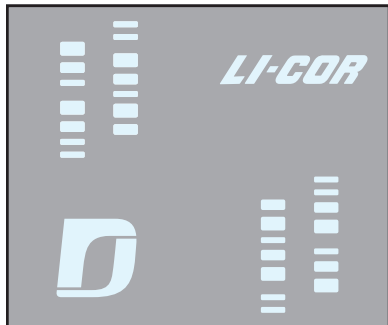
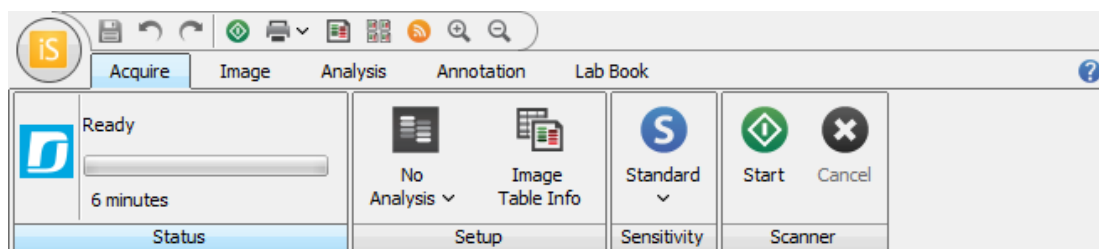

Figure 4-1. Expose this side.



13) Acquire Target Image

Make sure that the Sensitivity is set to Standard. If the Sensitivity is not set to Standard, click on the Sensitivity button and choose Standard from the pull-down menu (below). The image acquisition using Standard sensitivity takes approximately 6 minutes to complete.



Click the Start button on the Acquire tab ribbon.

The image acquisition will start, and the target image will be displayed as a series of six images of various brightness/contrasts (Step 14).



[Click here to watch a video that demonstrates how to acquire an image.](#)

14) Adjust Target Image

Verify that your target image acquisition is similar to that shown below. If it matches, your C-DiGit is functioning correctly. NOTE: Store the Target in its envelope when not in use. You will generally not need to use the Target after this initial verification step; it may be used later, however, for diagnostic purposes if there is a problem with the instrument.

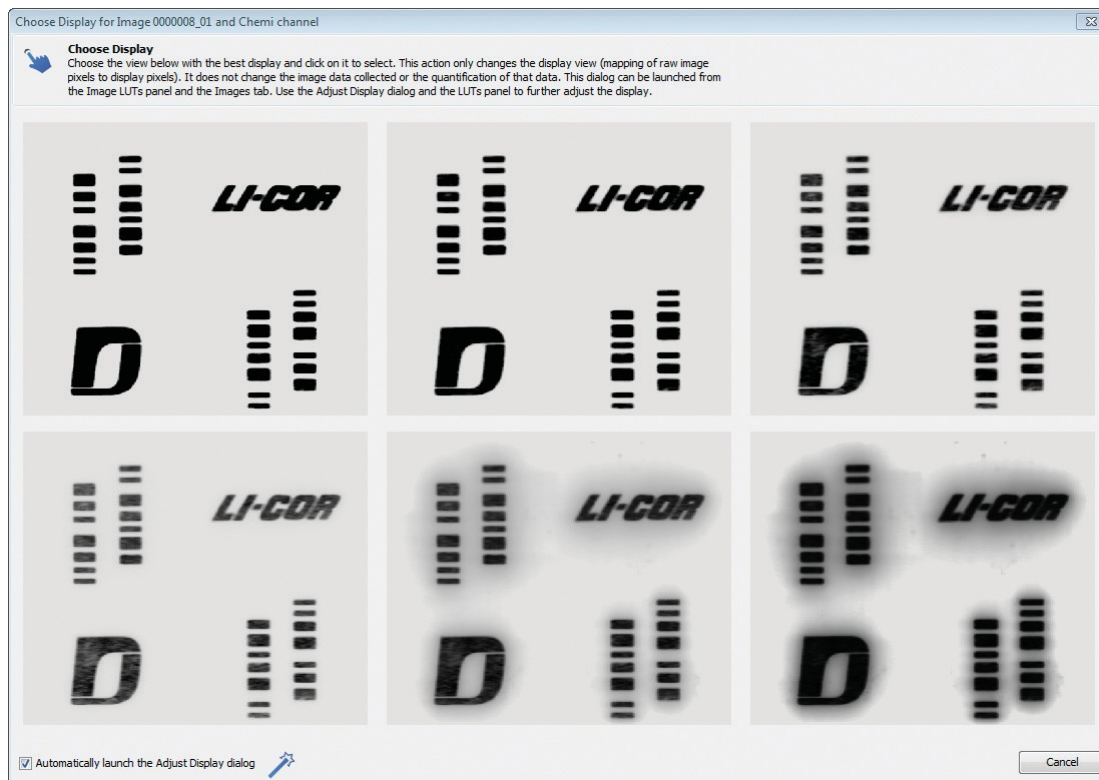

Click on the best image; that image will open in a new window (below), allowing for further adjustment, if desired. Click on Signal, Background, or Midtones to adjust the brightness for these channels, if needed. Click Done.

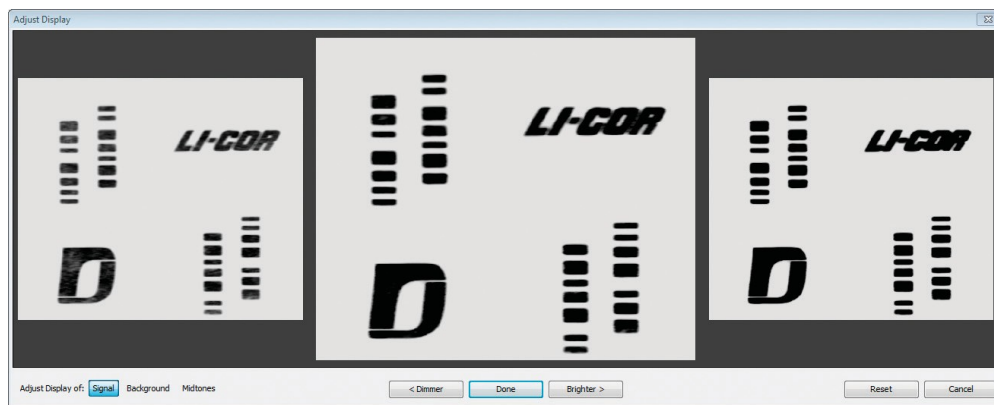

[Click here to watch a video that demonstrates how to choose and adjust an acquired image.](#)

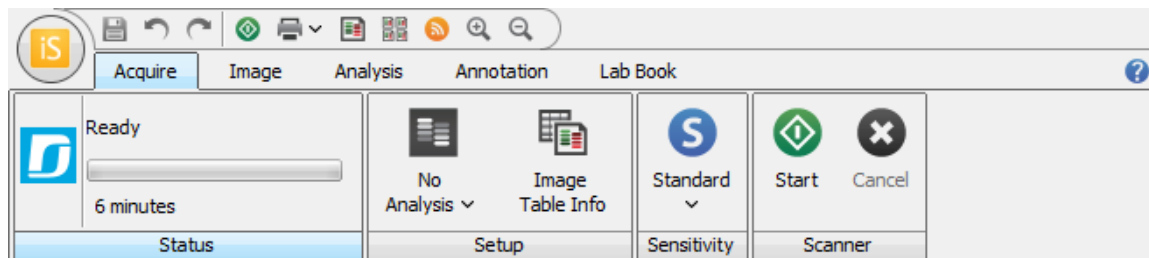

Click on the ribbon tabs (above) for additional features, including:

Image - Adjust the image appearance, crop, rotate, view image array.

Analysis - Draw shapes to quantify data.

Annotation - Add text annotations to image.

Lab Book - Create a .pdf file containing images, data tables, and charts.

Click on the **Shapes** and/or **Images** tabs at the bottom of the main window to view:

Shapes - Table of quantification data for selected image.

Images - Table of acquired images, settings, and comments.

The screenshot displays the C-DiGit Blot Scanner software interface. At the top, there is a menu bar with options: Acquire, Image, Analysis, Annotation, and Lab Book. Below the menu bar are several toolbars: Select, Shape, Edit, Auto-Adjust, Background, and Show. The main image area shows a blot with three lanes labeled 1, 2, and 3. Below each lane, the values 27500, 15600, and 5190 are displayed. To the right of the main image area is a Features panel with sliders for Brightness and Contrast, and a color bar. At the bottom of the interface is an Images table with the following data:

Image ID	Image Name	Image Modifications	Channels	Intensities	Scan Height	Scan Width	Resolution
0000054_01	0000072_02_700....		W		11.0	13.0	125um
0000055_01	0000072_02_Th.jpg		R G B		3.7	4.4	353um
0000056_01	0002822_01_Th.jpg	Data Inverted During Import	R G B		3.7	4.4	353um

Chapter 3: Scanning Membranes

For Western blotting methods, nitrocellulose or PVDF membranes may be used. LI-COR offers Odyssey nitrocellulose membranes (10 membranes; 0.22 μm , 7 cm x 8.5 cm) under part number 926-31090. There are some general tips for using membranes:

- **IMPORTANT:** Do not touch the membrane – handle only with clean forceps. Lift the membrane only by the corners.
- Keep the membrane wet if it is to be stripped and re-used. This can easily be accomplished by wrapping the membrane in plastic wrap.
- Use clean containers to avoid cross-contamination and reduce background.
- Multiple membranes can be washed together, provided there is ample volume so each membrane moves freely.

Generally speaking, chemiluminescent detection protocols for Western blotting do not need to be modified for use with the C-DiGit Blot Scanner. LI-COR does, however, have a variety of resources available for optimizing Western blots. Some of the most common questions regarding imaging with the C-DiGit Blot Scanner are listed below; more detailed support materials can be found at:

licor.com/bio/applications/chemiluminescent-western-blots

Placing the Membrane on the C-DiGit Blot Scanner Scanning Surface

The imaging surface is designed to scan a single membrane up to 10 x 8.5 cm. Place the membrane face down, with the top of the membrane facing the back of the instrument.



[Click here to watch a video that demonstrates how to place a membrane on the C-DiGit Blot Scanner.](#)

Using Blocking Buffer

1) Can I use Odyssey® blocking buffer to block my blot?

Yes. Use only for the blocking step and be aware that the sodium azide from the Odyssey blocking buffer may still be present on the membrane at the detection step and will bind to the HRP enzyme, resulting in reduced light production and less intense bands.

2) Can I use milk-based blockers?

Yes. Milk-based blockers can be used for chemiluminescent detection but should be avoided when detecting phosphoproteins or glycoproteins. Milk-based blockers may contain endogenous biotin and glycoproteins, resulting in higher background on the membrane.

3) Can I dilute the HRP-conjugated secondary antibodies in Odyssey® blocking buffer?

No. Odyssey blocking buffer contains sodium azide as a preservative. Sodium azide binds irreversibly to the HRP enzyme, inhibiting the binding of the substrate and slowing the chemiluminescent reaction. This results in less light production that may affect the appearance of less intense bands or even the entire blot. For optimal results do not use any solutions containing sodium azide for chemiluminescent Western blotting (for either secondary or primary antibodies).

- 4) What is the best blocker for chemiluminescent Western blots?

It is best to try several blockers to find the one that gives the most satisfying data for each antigen and antibody pair. There is not an optimum blocker for all conditions.

Primary and Secondary Antibodies

- 1) Why is the signal missing in the middle of the bands?

Too much secondary antibody on the membrane results in consumption of all of the substrate in that area. Without substrate, there is no chemiluminescent signal and a blank spot appears in the center of the band. Try different dilutions of the primary and secondary antibodies to find what gives the best results, or try changing the substrate.

- 2) Does it matter where I purchase the HRP-conjugated secondary antibodies?

The reactivity of secondary antibodies ranges widely between vendors. The ratio of HRP enzyme to antibody varies as well, and may affect the detection of the target. If the secondary antibodies from one vendor are not working, trying antibodies from LI-COR or other vendors may be helpful. LI-COR offers the WesternSure® Goat anti-Mouse HRP secondary antibody under part number 926-80010, and the WesternSure Goat anti-Rabbit HRP secondary antibody under part number 926-80011.

- 3) Should the HRP-conjugated secondary antibodies be highly cross-adsorbed?

Although highly cross-adsorbed antibodies are essential for two-channel, multiplex detection, it is not always necessary with chemiluminescent blotting for a single target.

Washing Buffer

- 1) Does it matter how I wash the membranes after antibody incubation?

Yes. Adequately washing the membranes will greatly improve the appearance of the chemiluminescent Western blot. Wash the membranes with a saline-buffered solution containing 0.05 to 0.1% of a non-ionic detergent such as Tween® 20. Wash four times for five minutes each on a shaker or rotator with ample wash solution.

Substrates

- 1) Which substrate should I use?

There are a wide variety of chemiluminescent substrates for HRP detection. In general, substrates with a faster reaction rate tend to be more sensitive. The C-DiGit Blot Scanner is designed to work well with most substrates. LI-COR carries a line of chemiluminescent substrates that have

been optimized to work with the C-DiGit Blot Scanner; two of these substrates are WesternSure ECL (p/n 926-80100) and WesternSure PREMIUM (p/n 926-95000).

- 2) How do I apply the substrate?

Make sure the substrate is at room temperature before use. Substrate should be applied by following the manufacturer's suggested methods for the amount of substrate to use and the incubation time prior to imaging. The substrate can be directly added to the sample side of the membrane (either by pipetting the substrate on the sample surface, or by preincubating the membrane in the substrate), allowed to incubate, and scanned without having to wrap the membrane before scanning. Membranes can also be wrapped in a plastic covering prior to scanning.

- 3) The membrane dried during imaging. Can I apply more substrate and image again?

No. Applying more substrate to a dried blot will likely result in high background.

- 4) How do I keep the membrane from drying out?

In general, the membrane should not dry out in the amount of time it takes to complete a scan. However, to maintain moisture on the membrane for an extended amount of time, place a clear, flat plastic covering on top of the chemiluminescent Western blot to keep the substrate in contact with the HRP enzyme and to prevent the blot from drying out. Membranes can also be completely wrapped in plastic covering prior to scanning (see *Scanning Membranes* on page 27). Make sure there is no plastic wrap extending out past the scanning surface and into the outer lid seal.

Imaging

- 1) Can I wrap the blot in plastic wrap before imaging?

As long as the plastic is clear, clean, and wrinkle free (the plastic wrap may cause unwanted background, especially if it is folded or handled roughly), the blot can be wrapped in plastic before imaging. Note that plastic wrap will cause unwanted background; we recommend using plastic wrap only if you must seal the membranes.

- 2) Why are the bands on my blot so light?

Use the Lookup Table (LUT) in Image Studio to adjust how data are mapped to the display pixels of your computer screen.

You can view the Image LUTs as either slider bars (the default view, below left) or as histograms overlaid with a curve (below right). To hide this view, click the double arrows in the top right corner.

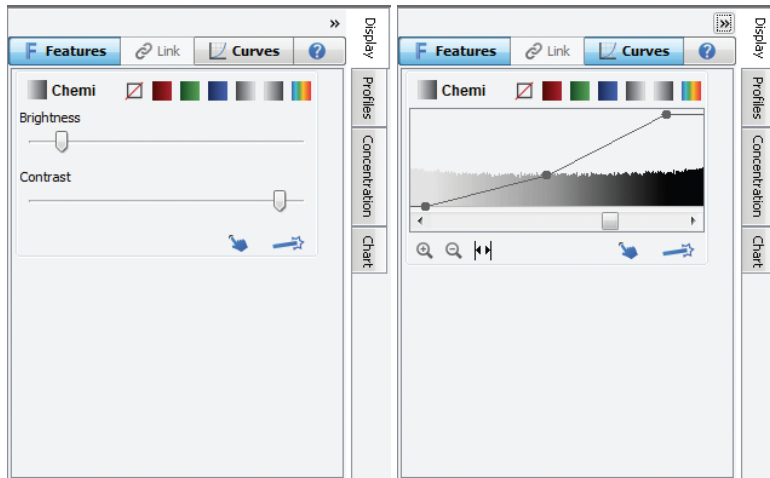

Overlaying the LUT histogram is a curve with three adjustable points (above right). Move the top Max Point to the left to map more of the higher intensity data to the brighter display pixels to make the bands appear brighter. Move the lower Min Point to the right to map the lower intensity data to the background color, creating a visually cleaner background. The middle point smoothly adjusts the mapping from linear to logarithmic. Changing to a more logarithmic mapping reduces the contrast between the lower and higher intensity data, so the appearance of less intense bands is improved while avoiding overly dark bands.

To change the Image LUTs from histograms (Curves) to Brightness/Contrast sliders, and vice versa, click on the Curves tab in the Image LUTs to toggle between histograms and Brightness/Contrast.

Chapter 4: Computer Connections & Networking

The C-DiGit Blot Scanner uses IPv4 and IPv6 Link-Local Addressing to automatically create an IP network without any user configuration or additional servers. If you are using Windows 7, 8 or 8.1 and you experience connection problems, be sure that IPv6 is enabled on the computer.

Note: Use only the supplied USB 2.0 Type A to Type B cable or Cat. 5E RJ45 Ethernet cable to connect the C-DiGit Blot Scanner and computer. The Ethernet port on the C-DiGit Blot Scanner is Auto-MDIX, so a crossover cable is not needed.

When Image Studio™ Software starts, it searches for and discovers any

C-DiGit Blot Scanners automatically. If only one instrument is found, Image Studio Application Software establishes communication.

If more than one instrument is found, the user is presented with a list of instruments and asked which to use.

Because the C-DiGit Blot Scanner is a networkable device, there are a variety of connection and/or networking options available. Some networking configurations may require assistance from your IT professional.

In general, there are two basic cabling configurations outlined below: 1) computer is connected to C-DiGit directly via the USB cable included, or; 2) computer is connected to C-DiGit directly via the Ethernet cable included.

Computer Connections and Networking

Direct Connection Via USB Cable

Use the supplied USB cable (p/n 392-13201) to connect your computer and C-DiGit Blot Scanner, as shown below.

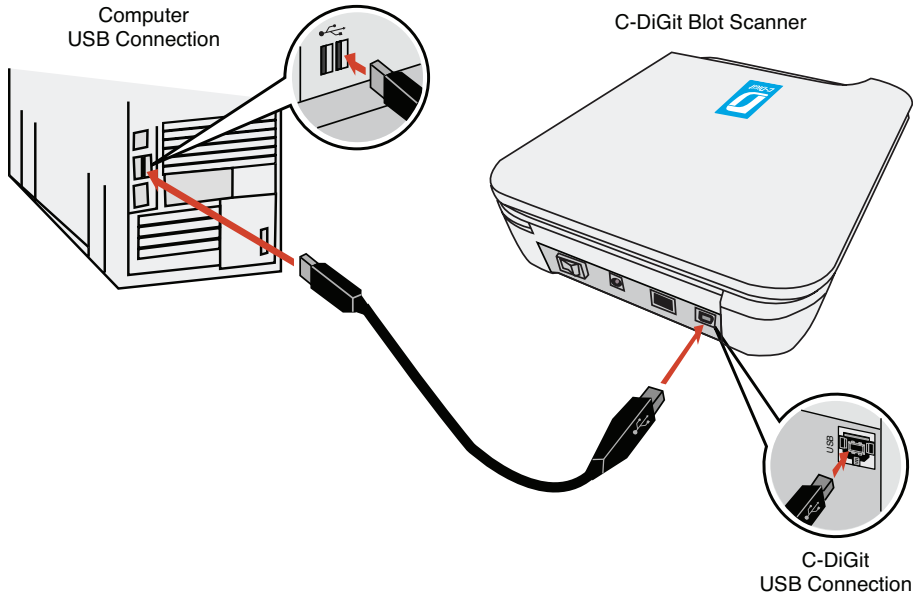

Direct Connection Via Ethernet Cable

Use the supplied Ethernet cable (p/n 616-06116) to connect your computer and C-DiGit Blot Scanner, as shown below.

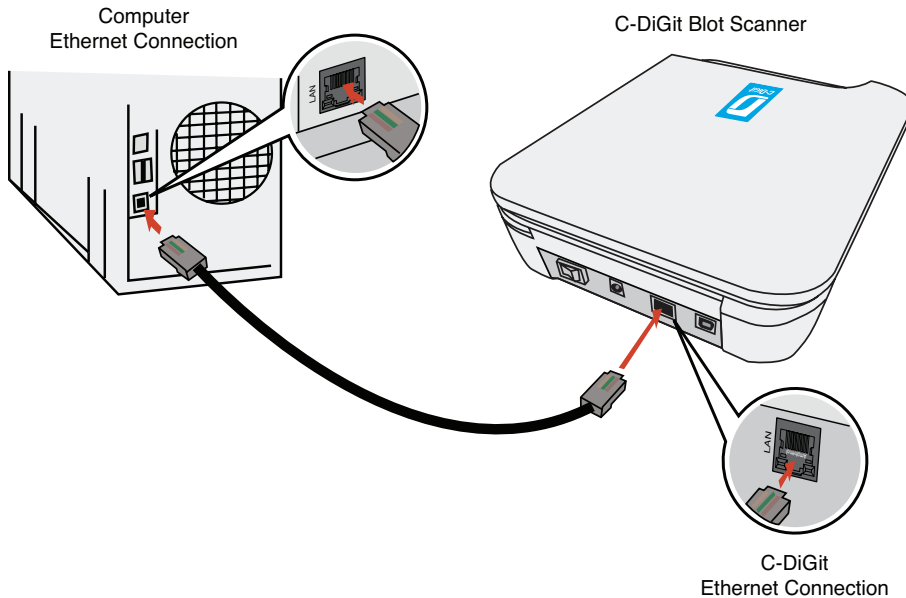

Chapter 5: Maintenance & Troubleshooting

Maintenance

The C-DiGit Blot Scanner requires only minimal maintenance. However, as with any equipment utilizing electrical power, there is a danger of fire or electrical shock if the equipment is not properly maintained.

Disconnect power before servicing. LI-COR Biosciences recommends that you routinely inspect the system. The following are some general maintenance guidelines:

- Clean the exterior case parts with warm water and a damp cloth.
- Clean the scanning surface with 100% methanol, then water.
- **CAUTION: DO NOT** use acetone to clean the imaging surface.
- Wipe all chemical spills from the case and scanning surface to prevent damage to the surface coating.
- Keep the scanning surface free of harsh solvents and other combustibles. Dry thoroughly before use.
- Inspect all cables and power cords for evidence of fraying, exposed wire, or loose connections.
- Do not allow sample or sample covering to extend past the imaging surface. This can prevent the instrument from operating properly by allowing light to enter the scan area.

Troubleshooting –Hardware Problems

System Requirements

The C-DiGit Blot Scanner and Image Studio will run on Windows 7, 8 and 8.1, or on Mac OS 10.9 or 10.10.

Cannot Connect to C-DiGit Blot Scanner

- 1) Install the Image Studio Software before you try to connect the USB or Ethernet cable to the C-DiGit Blot Scanner.
- 2) If the Image Studio software does not automatically connect to the C-DiGit Blot Scanner, manually connect by clicking the Image Studio Application button, and choose Instrument->Connect.

In the event that the C-DiGit Blot Scanner is unable to connect to a computer, your IT department may need to make specific configurations active on the computer for communication to occur.

The C-DiGit Blot Scanner requires a network based connection between the instrument and the computer. The C-DiGit Blot Scanner uses IPv4 and IPv6 Link-

Local Addressing to automatically create an IP network without any user configuration or additional servers. For this addressing to occur properly, the following settings must be configured:

- 1) Port 50000 must be open (Windows 7, 8, and 8.1).

Communication port 50000 is utilized as the default port for the UPnP (Universal Plug and Play) protocol. This service is noted to hold this network port consistently open, listening for devices that support the technology. This port simplifies intelligent device connection to network environments. The network port 50000 makes it possible for devices physically connected to a single machine to be shared with other clients under the same network.

- 2) Port 5353 needs to be left open. This is required for Bonjour, mDNSResponder to auto discover instrument.
- 3) Firewall should not block any part of Image Studio or the Java software platform that is installed with Image Studio.
- 4) Firewall should not block port 50000.
- 5) IPv6 must be enabled (Windows 7, 8, and 8.1).

USB Cabling Problems

If you are experiencing problems connecting to the C-DiGit Blot Scanner using the USB cable, note the following:

- The Image Studio installer for C-DiGit includes the required USB RNDIS driver.
- Image Studio must be installed on Windows before the USB cable is connected between the C-DiGit and the computer.
- After the Image Studio installation is complete, connect the USB cable between the PC and the instrument and power on the instrument. There should be a system notification that new hardware is found. Depending upon the system, this notification may take place immediately when the cable is plugged in or it may be a few minutes later.
- During the Windows new hardware installation, the system may give the user a choice between discovering drivers on the internet or from the local installation. If the computer is connected to the internet, pick the selection that looks for drivers on the internet. If the computer is not on the internet you may need to specify the location. If the drivers are not found automatically, choose 'Install from a list or specific location', and navigate to the <Program Files\Licor\Image Studio Digits\driver> folder.
- After installing the driver, start Image Studio and attempt to connect.

Front Panel Warning Light Indicates an Error

When the C-DiGit Blot Scanner is unable to complete a task requested by Image Studio Application Software, or a hardware failure is encountered, the red error indicator on the C-DiGit front panel (Figure 3-3) flashes and an audible alarm sounds. This error condition is automatically cleared after a few seconds and a message is displayed in the Image Studio Application Software status bar at the bottom of the main window (below) to explain the error. Click on the button to open the Status Message History dialog to view all diagnostic records.

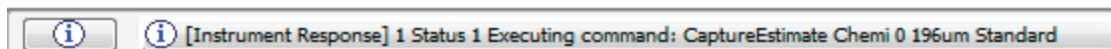

The error message will instruct the user on any further required action.

Resetting the Instrument

In the event that the C-DiGit Blot Scanner becomes unresponsive, reset the instrument by switching the rear power switch off for a few seconds, then back on. This procedure cuts power to the instrument and should only be used when communication cannot be re-established by any other means. The C-DiGit Blot Scanner should resume normal operation after start up but may take several minutes.

Troubleshooting –Chemistry Problems

High background can be caused by a variety of sources, including washing methods, secondary antibody concentration, and substrate choice. Background can be reduced by altering these sources.

High Background Due to Substrate

Pools of excess substrate on the membrane can lead to areas of high background, as can adding more substrate to a membrane that has dried. Apply the substrate carefully and wick off any pools of substrate before imaging. Do not allow the membrane to dry.

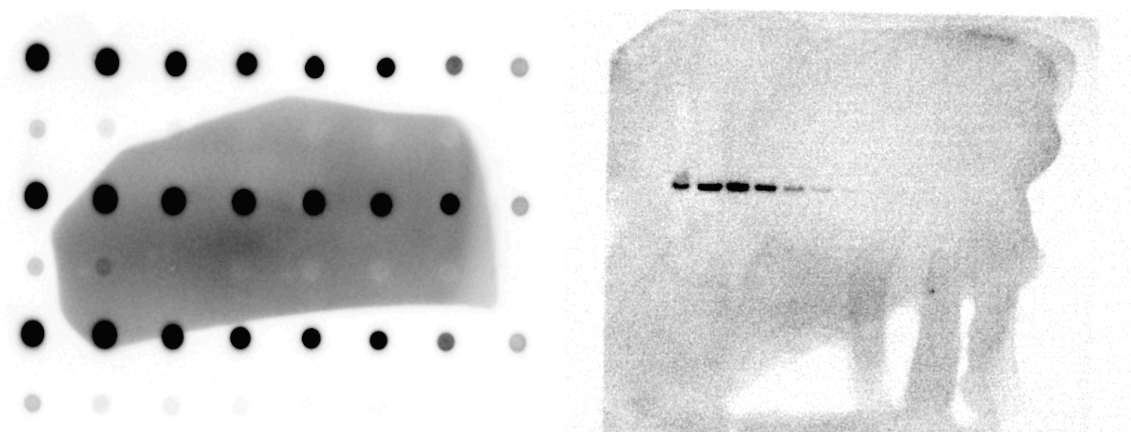

A. Pooled Substrate

B. Substrate Addition to Dried Blot

Figure 7-1. High background due to excess substrate (A), and addition of substrate to a dried blot (B).

High Background from Wrapping the Blot in Plastic Wrap

Blots can be imaged directly on the C-DiGit Blot Scanner without wrapping in plastic wrap. In general, the membrane should not dry out in the amount of time it takes to complete a scan. However, to maintain moisture on the membrane for an extended amount of time, you can place a clear, flat plastic covering on top of the chemiluminescent Western blot to keep the substrate in contact with the HRP enzyme and to prevent the blot from drying out. It will also minimize pooling of the substrate.

Image the plastic covering by itself first to determine if it scatters light, causing high background. You may need to try several types of plastic coverings before finding the best one.

Wrapping the blot in plastic wrap may cause unwanted background, especially if it is folded or handled roughly. When using plastic wrap it is important to avoid wrinkles, as they scatter light, resulting in high background. In addition, try to avoid leaving fingerprints from pressing on the blot.

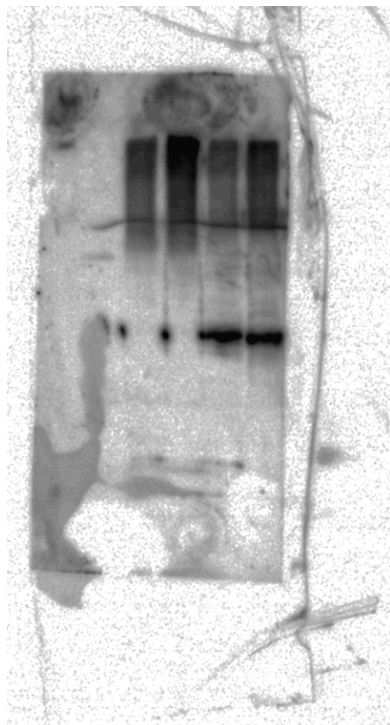

Figure 7-2. Unwanted background caused by plastic wrap.

Low Signal

The C-DiGit Blot Scanner should be set to High Sensitivity to generate the highest signal. Chemiluminescent substrates vary in quality and effectiveness, and using a substrate from a different source may improve signal. Varying the primary and secondary antibody dilutions may also affect the signal and background of a blot.

Troubleshooting –Image Studio™ Software Problems

Q: What image resolution can I export?

A: Image Studio can export images at resolutions up to 600 dpi in TIF, JPG, and PNG format.

Q: Why doesn't my image import into Image Studio?

A: Image Studio supports TIFF, JPG and PNG files. These file formats come in numerous forms. If your TIFF, JPG or PNG file does not import, please send the image to LI-COR so that future updates will be compatible with your image file format.

Q: Why is there a cyan color (grayscale image) or a bright white color (color image) on my image in Image Studio?

A: The signal is saturated in these areas.

Q: Can I add additional keys to Image Studio for C-DiGit?

A: Yes. For expanded functionality, optional application keys are available. Please visit www.licor.com/AnalysisKeys or ask your sales representative for more information.

Q: Can I use marker lanes in my gel analysis in Image Studio for C-DiGit?

A: Yes, but you will need to purchase and import the In-Cell Western Analysis Key (Image Studio Lite/C-DiGit), P/N 2000-521.

Q: Will Image Studio for C-DiGit work on Windows 8?

A: Yes. Image Studio 5.x for C-DiGit is currently supported on Windows 8.0, 8.1, and 8.1 update 2 (also known as 8.2).

Q: When I try to connect to the C-DiGit Scanner, I see a list of multiple instruments. How do I know which one to choose?

A: If there are multiple C-DiGit Blot Scanners connected, you will have to choose the desired C-DiGit Blot Scanner from a list of available instruments listed by serial number. You can find the serial number on a label on the underside of the instrument.

Obtaining Technical Support

To resolve a problem with your C-DiGit Blot Scanner, start by contacting LI-COR Technical Support at licor.com/support, or sending an e-mail to biohelp@licor.com. Outside of the U.S., contact your local sales office or distributor. Be prepared to give the serial number of your instrument, which can be found on a label on the instrument underside.

LI-COR Technical Support may ask you to provide copies of the instrument log files to aid in diagnosing problems.

Exporting Image Studio Software Log Files

To export and share a log file with Technical Support:

- 1) Click the **Image Studio Application Button**, point to **Logs**, and then click Export.

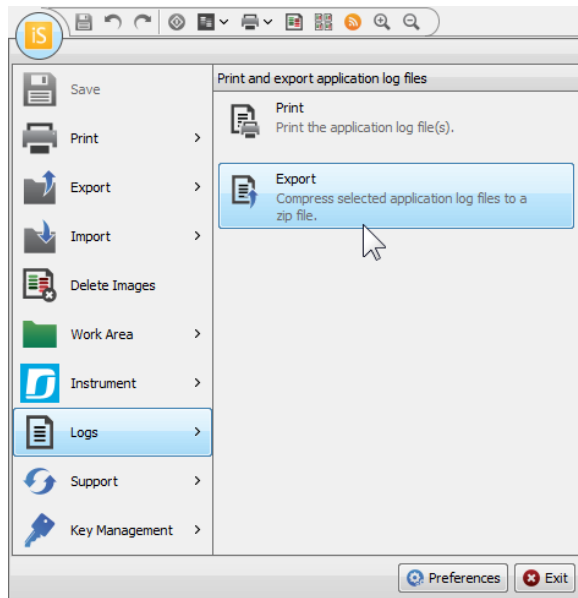

The **Zip Application Log Files** dialog will open.

- 2) In the **Zip Application Log Files** dialog, select **Most recent 2 Meg of log files** and choose where to save the file.

The exported file will be called EventLogs.zip.

- 3) Save the log file and email it to the address recommended by Technical Support.

Chapter 6: Specifications

Image Area: 10.0 cm x 8.5 cm

Resolution: 196 μm x 196 μm

Operating Conditions: For indoor use only; operating temperature 15-30 °C and dew point not greater than 25 °C, non-condensing; maximum operating temperature may be reduced at elevations above 2000 m.

Storage Temperature: -30-65 °C with non-condensing humidity from 0 to 90%

Depth of Field for Best Sample Focus: 0-0.5 mm off the glass. Static.

Detector Type: Low-noise CCD.

Acquisition Times: Approximately 6 minutes (Standard) and 12 minutes (High).

Image Generation and Format: 16 bit floating point tiffs.

Image Display Options: Pseudocolor, positive and negative grayscale, single color (red, green or blue).

Power Requirements: 12VDC, 1A maximum, provided by external power supply. External power supply requires 100-240 VAC (voltage fluctuations not to exceed 10% of the nominal voltage), 1A maximum, 50-60 Hz.

Connections to Computer: Cat. 5E RJ45 cable (10BASE-T/100BASE-TX) or USB 2.0 Type A to Type B cable. Use only the supplied cables.

Product Dimensions: 27.94 cm L x 22.23 w x 7.3 H (11" L x 8.75" W x 2.875" H)

Weight: 2.18 kg (4.8 lbs.)

Product Includes: C-DiGit Blot Scanner, target image, external power supply, Ethernet cable, USB cable, and software and resource CDs.

Chapter 7: Training Video Links

The following are links to training videos for the C-DiGit Blot Scanner; these links are also present in this guide at appropriate locations.



[Scene 1-Introduction](#)



[Scene 2.1 -Requirements for Image Studio](#)



[Scene 2.2 -How to Install Image Studio on Windows](#)



[Scene 2.3 -How to Install Image Studio on Macintosh](#)



[Scene 3-Creating a Work Area Folder](#)



[Scene 4-Acquiring an Image on the C-DiGit Blot Scanner](#)



[Scene 5-Choosing and Adjusting an Acquired Image](#)



[Scene 6-Quantifying Data](#)



[Scene 7-Setting the Background Subtraction Method](#)



[Scene 8—Adjusting the Image Appearance](#)



[Scene 9—Annotating Images](#)



[Scene 10—Exporting Data](#)



[Scene 11—Printing Lab Reports](#)



[Scene 12—Importing Images](#)



[Scene 13—Placing a Blot on the C-DiGit Blot Scanner](#)

Chapter 8: Embedded Firmware Source Code

The embedded firmware running on the C-DiGit Blot Scanner (model number 3600) utilizes open source software. To obtain source code or related information, contact LI-COR Support at <http://www.licor.com/biotechsupport>.

