

qube™
91390



©2014 Spacelabs Healthcare

All rights reserved. Contents of this publication may not be reproduced in any form without the written permission of Spacelabs Healthcare. Products of Spacelabs Healthcare are covered by U.S. and foreign patents and/or pending patents. Printed in U.S.A. Specifications and price change privileges are reserved.

Spacelabs Healthcare considers itself responsible for the effects on safety, reliability and performance of the equipment only if:

- assembly operations, re-adjustments, modifications or repairs are carried out by persons authorized by Spacelabs Healthcare, and
- the electrical installation of the relevant room complies with the requirements of the standard in force, and
- the equipment is used in accordance with the operations manual.

Spacelabs Healthcare will make available, on request, such circuit diagrams, component part lists, descriptions, calibration instructions or other information which will assist appropriately qualified technical personnel to repair those parts of the equipment which are classified by Spacelabs Healthcare as field repairable.

Spacelabs Healthcare is committed to providing comprehensive customer support beginning with your initial inquiry through purchase, training, and service for the life of your Spacelabs Healthcare equipment.

CORPORATE OFFICES

Corporate Headquarters

Spacelabs Healthcare, Inc.

35301 SE Center Street
Snoqualmie, WA 98065
U.S.A.
Telephone: (1) 800-287-7108
Telephone: (1) 425-396-3300

Authorized EC Representative

EC REP Spacelabs Healthcare, Ltd.

43 Moray Place
Edinburgh, EH3 6BT
Scotland
Telephone: 44 (0) 131 240 6481
Fax: 44 (0) 131 240 6459

Please refer to <http://www.spacelabshealthcare.com/en/company/trademarks> for a full listing of Spacelabs Healthcare trademarks. Other brands and product names used herein are trademarks of their respective owners.



- **Rx Only** U.S. Federal law restricts the devices documented herein to sale by or on the order of a physician.
- Before use, carefully read the instructions, including all warnings and cautions.



Table of Contents

1 Introduction

Overview.....	1-1
Warnings, Cautions, and Notes.....	1-2
Product Specifications	1-3
Electrical Specifications.....	1-5
Classification	1-5
Environmental Requirements.....	1-6
Transport and Storage	1-6
Operating	1-6
Expected Service Life.....	1-6
Monitor Options.....	1-7
Product Overview	1-7
Monitor Assembly and Module Housing	1-7
External AC Power Supply	1-8
Batteries	1-8
Display	1-8
LCD Display	1-8
Video Subsystem	1-8
Basic Components.....	1-9
Battery Indicators	1-10
Energy Saving Mode (Battery)	1-13
Signal Strength Indicator	1-13
Batteries and Recharging Batteries.....	1-14
To change batteries without interruptions while operating on battery power	1-15
Battery Power Level	1-15
Architecture.....	1-16
Directory of Keys.....	1-17

2 Setup

Unpack the Monitor.....	2-1
Display Assembly	2-2
Input/Output Connections (Internal and External)	2-3
Power LED	2-9
Battery Status LED	2-9
Alarms	2-9
Cables	2-9
Maximum Cable Lengths	2-9
SDLC External Devices	2-9
SDLC Cable Interconnection	2-15
SDLC Bus Termination	2-15
Alarm Relay for option A	2-15
Power-ON Test.....	2-17
Configure the Monitor	2-17
Privileged Access Menus	2-17



3 Theory

- CPU PCB 3-1
- Battery Charger and Power Supply Subsection (on CPU PCB) 3-4
- Li-Ion Batteries 3-5
- Battery Switch PCBA for Options B and C 3-7
- Monitor Docking PCBA and Connector PCBA 3-8
- Front Bezel Assembly 3-9
- Pod Interface PCB 3-10
- Interconnect PCB 3-10

4 Maintenance

- Overview 4-1
- Required Test Equipment 4-2
- Mechanical Inspection 4-2
- Tests for Electrical Safety 4-2
- Definitions 4-2
 - Equipment Required 4-3
- Ground Resistance 4-3
- Chassis Leakage Current Tests 4-4
- Patient Lead Leakage Current Tests (Patient Modules) 4-4
- Preventive Maintenance 4-4
- Touchscreen Calibration 4-4
 - To perform touchscreen calibration 4-4
- Functional Tests 4-5
- Monitor Self-Test 4-5
- Monitor Functional Tests 4-5
 - Verification of Monitor Functions 4-5
 - Optional Recorder Assembly for Options A and B 4-6
 - External Alarm Relay Output for Option A 4-6
 - Ethernet (Wired) 4-7
- Assembly/Disassembly Procedures 4-7
- Required Tools and Parts 4-7
- Setup for Disassembly 4-7
 - For Option A 4-8
 - For Options B and C 4-8
- Remove the Bezel Assembly 4-8
 - Reassembly 4-10
- CPU PCB 4-11
- Restore Data to the Monitor 4-14
 - Option 1: Exchange the USB Drive PCBAs 4-14
 - Option 2: Format the USB Drive 4-14
- Complete Main Chassis Removal 4-17
- Reinstall the Chassis 4-18
- SDLC Interface PCB 4-19
- Speaker 4-20
- Mon-Dock PCB 4-21
- Battery Door for Option A 4-22
- Connector Board PCB 4-23
- Replace the Battery Contact PCB 4-24
- Replace and Align the Module Door 4-25
- Handle 4-26
- Reinstall the Rear Handle Assembly 4-26
- Fan 4-27
- Install or Replace the Optional Recorder Assembly 4-28
 - To install the recorder 4-28
 - To replace the recorder 4-29





Insert Recorder Paper	4-29
To insert a roll of paper	4-29
Dock Connector Covers for Option A	4-29
Removal of Pod Interface PCBA for Options A and B	4-30
Reinstallation of the Pod Interface PCBA	4-30
Docking Station PCBA Replacement Procedures for Option A	4-31
Required Tools and Parts	4-31
Docking Station	4-31
Replace the Docking Station Latch	4-33
Replace the Docking Station Push Button	4-34
Cleaning	4-35

5 Troubleshooting

Overview.....	5-1
Required Tools and Parts	5-2
System Startup.....	5-2
System	5-3
Power-ON Diagnostics.....	5-3
Boot Menu.....	5-4
To access the Boot menu if the display is functional	5-4
Boot Parameters	5-6
Extended Diagnostics.....	5-7
Diagnostic Menus	5-8
Main Diagnostic Menu	5-8
Individual Diagnostic Menu	5-9
Memory Menu	5-10
Video Menu	5-11
Error Log.....	5-11
View the Error Log	5-12
Diagnostics Failure Messages and Error Codes	5-14
System Troubleshooting	5-16
Suggested Tools/Test Equipment	5-16
Qube Monitor Does Not Power ON	5-17
Qube Monitor Powers ON, But Fails System Startup	5-19
High-pitched Tones Heard from the qube Monitor and No Display is Present	5-21
System Software Failure Window Shown Immediately After System Startup	5-22
Monitor Fails Power-ON Diagnostics	5-23
Troubleshooting Method 1: Use the Touchscreen or Mouse	5-23
Troubleshooting Method 2: Use the Remote Terminal—Use When No Display is Present	5-23
Monitor Fails System Functions	5-24
Batteries/ Battery Charger	5-24
Touchscreen	5-24
Module does not sign on when installed in an external module housing	5-24
Module does not sign on when installed in the monitor for options A and B	5-25
Pod does not sign on	5-26
Module signs on but parameters do not function	5-26
Ethernet	5-26
External Alarm Relay for Option A	5-27
Keyboard, Mouse, or Barcode Scanner	5-27
Touchscreen	5-27
Ethernet/Network	5-28
External Alarm Relay/Nurse Alert for Option A	5-28



Keyboard, Mouse, or Barcode Scanner 5-29

6 Parts

Overview 6-1
Parts List 6-2
Option A 6-2
Option B 6-4
Option C 6-7
Assembly Drawings and Schematics 6-10

7 Glossary

A Appendix A – Electromagnetic Compatibility

Electromagnetic Emissions A-1
Electromagnetic Immunity A-2
Separation Distances A-3
Mitigation A-4

B Appendix B – Symbols





Introduction

Overview

Spacelabs Healthcare designs and manufactures its products under good manufacturing practices and in compliance with all applicable regulatory requirements. To make sure that the product operates correctly in accordance with these guidelines, trained technicians using Spacelabs Healthcare authorized replacement parts maintain this product.

The expected service life of the monitor is seven years from the date of installation, but its service life can be extended. Many of the monitor parts are replaceable. Calibration is not required, but routine safety checks are required. Install a functional battery in the unit for normal operation. Check the battery periodically and replace it when necessary.

The qube™ monitor has a 26.2 cm (12.1 inches) LCD display with 1024 x 768 resolution. It has an intuitive user interface and a stylish, compact design. The monitor includes a single module slot and supports up to three Flexports® and four USB devices (a mouse, keyboard, barcode scanner, etc.). Available options include an integrated recorder and 802.11a/b/g wireless. Dual-battery slots allow for its use as a transport monitor, as well as at the bedside.

The system has an improved performance and high-resolution LCD display system. The touchscreen has built-in alarm lights, LED status indicators (to show the power and battery state), and a power ON/OFF switch.

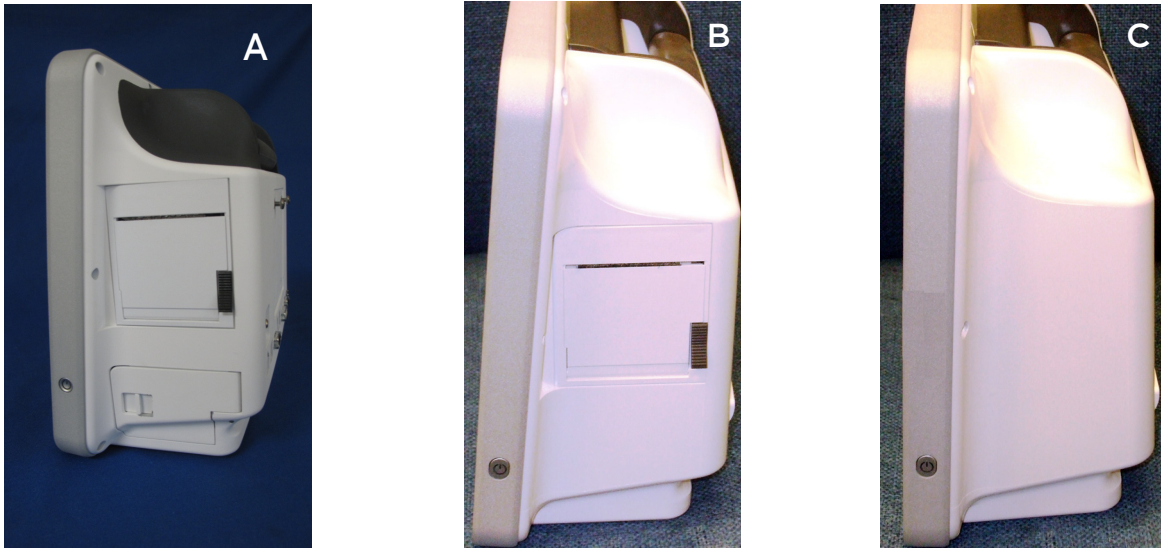

Figure 1-1 91390 qube monitor configuration options

- a qube with both printer and battery slots (option A)
- b qube with only printer slot (option B)
- c qube with no printer or battery slots (option C)

Note:

For more details refer to Table 1-1 on page 4.

Warnings, Cautions, and Notes

Warnings, cautions, and notes are used throughout this manual. The formats below show how warning, cautions, and notes are identified.

	Warning:
	Alerts the user to potentially serious outcomes (death, injury, or serious adverse events) to the patient or user.

	Caution:
	Alerts the user to actions to be taken to avoid non-serious injury to the patient or user, or to adverse effects to the device.

Note:

Failure to observe notifications can result in unexpected outcomes.



Product Specifications

Refer to [Basic Components](#) on page 1-9 for more information.

Product Specifications		
Physical Dimensions		
Height	26.2 cm	10.3 inches
Width	31.5 cm	12.4 inches
Depth	13.2 cm	5.2 inches
Weight	4.1 kg	9 lbs
Display		
Color thin film transistor (TFT) liquid crystal display (LCD), resistive touchscreen		
Resolution	1024 x 768 pixels	
Size- wide - high	24.6 cm 18.4 cm	9.7 inches 7.3 inches
Printing Method*	Thermal array print head	
Paper	Heat-sensitive paper roll, 50 mm wide x 30 m long	
Resolution	Eight dots per mm (vertical) and 32 dots per mm (horizontal) at 25 mm per second sweep speed	
Prints	Manual and automatic alarm recordings for waveforms, vital sign data, trends, calculations, and full annotations are included	
Controls	Continuous, Stop Recording, Compressed, Paper Advance	
Indicators	Paper out, Unit off	
Sweep Speed	Various speeds are available under module control.	

** May not be included in the qube configuration option package. For more details on configuration options, refer to [Qube Configuration Options](#) on page 1-4.*



Table 1-1 Qube Configuration Options

Connectors	A	B	C
Internal Recorder Slot	1 on right panel	1 on right panel	not included
Front Integrated Alarm Light	1 on top, front, and back of display	1 on front of display	not included
Docking Station	connection included	not included	not included
Integrated or Hot Swappable Battery Slot	2 Lithium-Ion (Li-Ion), right side below printer slot	2 Lithium-Ion (Li-Ion), fixed non-removable	1 Lithium-Ion (Li-Ion), fixed non-removable
Equipotential Terminal	1 on rear panel	not included	not included
DC Power Input	1 on rear panel	1 on rear panel	1 on rear panel
Ethernet 10/100 Base T Connection	1 on rear panel	1 on rear panel	1 on rear panel
Serial Port	1 on rear panel	1 on rear panel	1 on rear panel
USB Ports	4 on rear panel	2 on rear panel	2 on rear panel
Video Output, DVI-D	1 on rear panel	1 on rear panel	1 on rear panel
SDLC Port	1 on rear panel	1 on rear panel	1 on rear panel
Remote Alarm Output-Nurse Alert	1 on rear panel	not included	not included
Module Slot	1 on left panel	1 on left panel	1 on left panel
POD Connection	1 on rear panel	1 on rear panel	not included
Power On/Off Button	on right side of display	on right side of display	on right side of display





Electrical Specifications

Classification

	<p>Warning:</p> <ul style="list-style-type: none"> • <i>Use designated power supply only.</i> • <i>Do not modify this equipment without the authorization of the manufacturer.</i> • <i>To avoid electric shock, connect this equipment only to a supply mains with a protective earth conductor.</i>
---	--

- Class I - Requires outlet with Protective Earth (safety ground) conductor
- Mains Power: 100 - 240 VAC, 50 - 60 Hz, 3 - 1.5 A
- Rated for continuous operation
- Isolation: Leakage currents meet ANSI/AAMI ES 60601-1, CSA C22.2 No. 60601-1, and IEC 60601-1.
- Batteries: (For configuration options, refer to [Qube Configuration Options](#) on page 1-4).
 - 1** 10.8 Volt (7.2-Ah Li-ion) smart battery. One battery provides approximately 4 hours of operation. Two batteries allow up to approximately 8 hours of operation. There are approximately 300 charge/discharge cycles of operation for each battery.
 - 2** 10.8 Volt (4.8-Ah Li-ion) smart battery. One battery provides approximately 2 hours of operation. Two batteries allow up to approximately 4 hours of operation. There are approximately 300 charge/discharge cycles of operation for each battery.
 - 3** 10.8 Volt (4.8-Ah Li-ion) smart battery. One battery provides approximately 2 hours of operation. There are approximately 300 charge/discharge cycles of operation for each battery.

Note:

One battery charges in approximately two hours. Two batteries charge in approximately four hours.



Environmental Requirements

Transport and Storage

Temperature: -25° to 60° C (-13° to 140° F)

Humidity: 95% (non-condensing)

Altitude: 0 to 12,192 meters (0 to 40,000 feet)

Operating

Operating Temperature: 0° to 40° C (32° to 104° F)

Humidity: 95% (non-condensing)

Altitude: 0 to 4,572 meters (0 to 15,000 feet)

Expected Service Life

The expected service life is seven years from the date of first use. Spacelabs Healthcare recommends regular replacement of the following parts to extend service life:

- LCD
- LCD backlights
- batteries
- fan

Replace the listed items especially if you use them beyond the service life range. Perform safety checks and maintenance of the monitor on regular schedules. Spacelabs Healthcare offers a refurbishment program for equipment that has passed its expected service life. Contact your local service representative for more information.

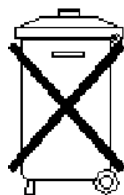

To protect the environment, properly dispose of all batteries, electronic assemblies, plastics, and metals.

Follow your internal procedures or local (provincial) laws regarding disposal or recycling.





Monitor Options

Table 1-2 91390 Monitor Options

Option	Definition
D	Perioperative; provides customizable, user-specific display setups and start case and end case functions
N	Vital Signs Calculations (Hemodynamics, Oxygenation, Ventilation, and Renal)
Q	Data Shuttle [®] supports the transfer for up to 96 hours of trend information
R	Patient Data Logger (PDL); presents an ASCII data stream of patient name and vital sign data to the serial port in a pre-defined format
S	Dynamic Network Access (DNA); Spacelabs Healthcare proprietary version of the Citrix ICA Client connects and interacts with remote applications hosted on Citrix servers. Citrix server software and other associated licenses and applications must be purchased separately.
U	Printer; one printer slot, refer to the product specifications section for details
V	Full View; supports simultaneous display of 12 ECG leads
W	Full Bed Review; provides a multi-parameter view for any monitored patient on the network (up to seven waveforms)
X	Wireless; 802.11a/b/g

Product Overview

Monitor Assembly and Module Housing

The monitor is a portable product that provides physical mounting, electrical connection, and power for a plug-in module. It also provides power and SDLC I/O for externally connected flexports and other devices. The monitor provides interfaces for:

- internal and optional external displays
- connections for a mouse, keyboard, barcode reader using USB
- remote control through IR remote control: option A (SL number 90360-01)
- the required video signals for an external display

A separate external power supply powers the monitor. All voltage conversion that is required to support the modules and the internal electronics is provided inside the product. Provisions are provided for detection of an AC line failure to provide for an orderly power off.



External AC Power Supply

The external AC supply that powers the monitor meets worldwide safety and EMC requirements. The external AC supply provides 20 VDC. The external AC supply provides 20 VDC at 4.5 Amps. The external power supply (an AC/DC converter) has a 6pin rectangular connector (P/N 119-0552-00).

Batteries

The option A monitor accommodates the use of two removable internal batteries. At least one battery must be installed for normal operation.

The option B monitor has two fixed (non-removable) batteries. The option C monitor has one fixed (non-removable) battery.

For more information, refer to [Batteries and Recharging Batteries](#) on page 1-14.

Display

LCD Display

For options A and B, the LCD display assembly provides multicolor visual alarm notification based on the severity of the alarm. The software controls the operation of the alarm lights. There is a red light for high priority, a yellow light for medium priority, and a cyan light for low priority and technical alarms.

The alarm lights are visible directly above the display screen on options A and B, and on the rear of the monitor above the handle on option A.

Video Subsystem

The primary display is a 12.1-inch color TFT LCD. The video interface is 24-bit Flat Panel Display Link (FPD-Link) using LVDS.

The display has an LED backlight supplied with 12-volt power. A PWM control signal controls the brightness of the LED backlight. The power supply microcontroller generates the PWM control signal under the direction of the host application.

The secondary display is an external monitor compatible with standard Digital Visual Interface (DVI) signaling. The interface is DVI-D which supports digital-only, single-link.

The secondary display has the same image and resolution as the primary display.





- Resolution 1024 x 768
- Active Lines 768
- Active Pixels 1024

Table 1-3 Display Specifications

Parameter	Minimum	Typical	Maximum	Unit	Remarks
Video Clock Rate	60.0	15.385	68.0	nS	65-MHz typ.
Horizontal Rate	19.67	20.676	22.4	uS	48.363-KHz typ.
Vertical Rate	13.3	16.666	18.5	mS	60-Hz typ.

Basic Components

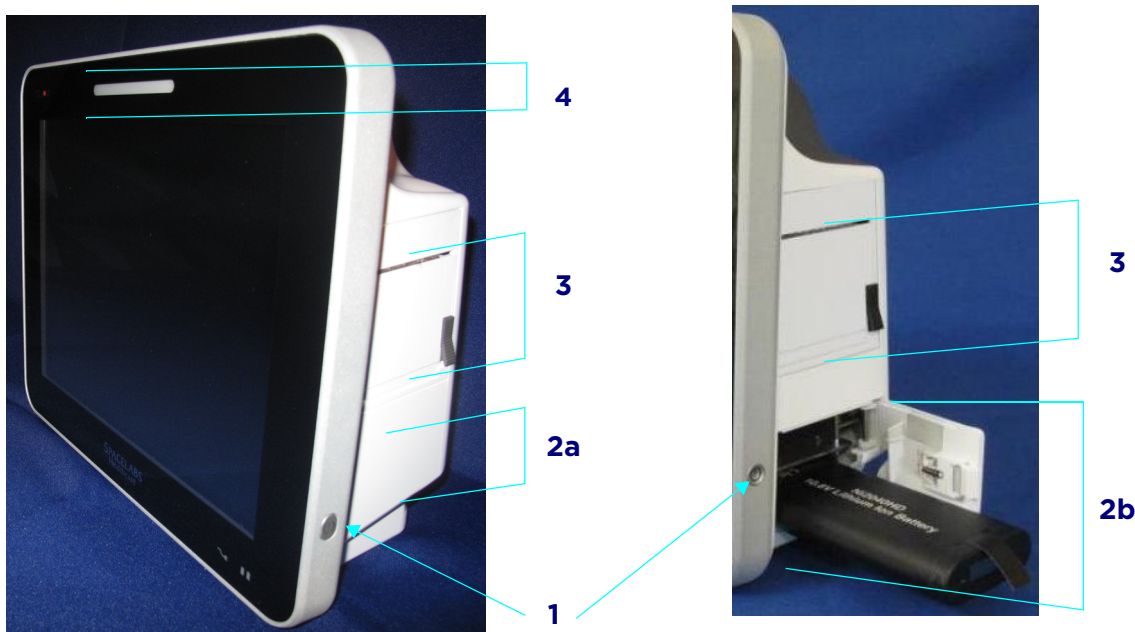



Figure 1-2 Front and Right Side of the Qube Option A

Callout Number	Description	Symbol
1	<p>Power On/Off Button- Press and hold the power button for at least three seconds to turn the monitor off. System shutdown progress is shown below the green power symbol.</p> <p><i>Note:</i> Hold the power On/Off for 3 seconds, or the monitor will not power off.</p>	<p>Figure 1-3 System shutdown progress</p>

Callout Number	Description	Symbol
2a	Integrated Battery Slot closed*	Refer to To change batteries without interruptions while operating on battery power on page 1-15 for details.
2b	Hot Swappable Battery Slot open with battery partially pulled out.*	Refer to To change batteries without interruptions while operating on battery power on page 1-15 for details.
3	Internal Recorder Slot*	N/A
4	Front Integrated Alarm Light*	N/A

* Not all of the qube configuration options include these items. For more details, refer to [Qube Configuration Options](#) on page 1-4.

Battery Indicators

	Warning:
	<i>At least one battery should always be installed in the monitor. The battery is a critical component of the electrical system. It improves EMC immunity performance when the monitor is connected to the AC power.</i>

Notes:

- The battery provides power to the monitor when it is separated from the AC power.
- Batteries charge when the monitor is connected to the AC power.
- The monitor auto-switches to battery operation when separated from the AC power.
- Remove batteries if the monitor is not likely to be used for some time.
- Remove batteries from the monitor before storage or shipment.

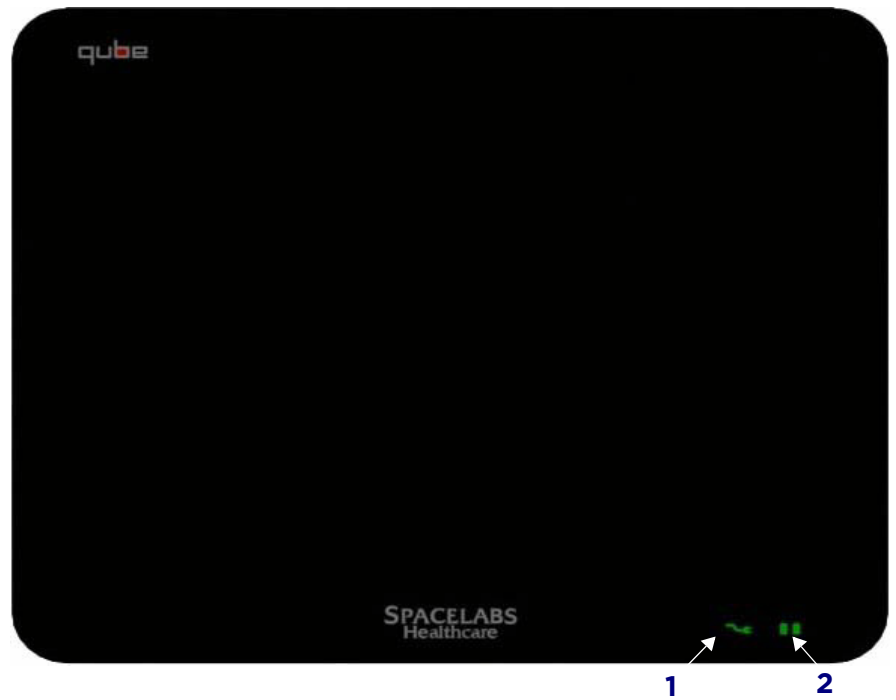
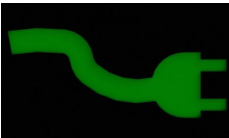
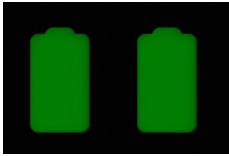

Figure 1-4 Battery charger and AC/DC power indicators

Table 1-4 Power Indicators (only shown when AC is connected)

	Description	Symbol on panel
<p>1</p>	<p>AC/DC Power Indicator - External power supply is connected to the monitor and the AC mains. When the AC power indicator comes on, the connection is good.</p> <p>Refer to Figure 1-4.</p>	
<p>2</p>	<p>Battery Charge Status Indicator- Shown if a battery is present. The left light shows if the top battery is installed. The right light shows if the bottom battery is installed.</p> <p>Flashing (rate of 1 second on and 1 second off) shows the battery is charging.</p> <p>Steady ON shows the battery is charged.</p> <p>Flashing, rapid or erratic shows the battery is faulty and must be replaced.</p> <p>Refer to Figure 1-4.</p> <p><i>Note:</i> <i>The option C monitor has one battery, so only one battery charge indicator shows.</i></p>	

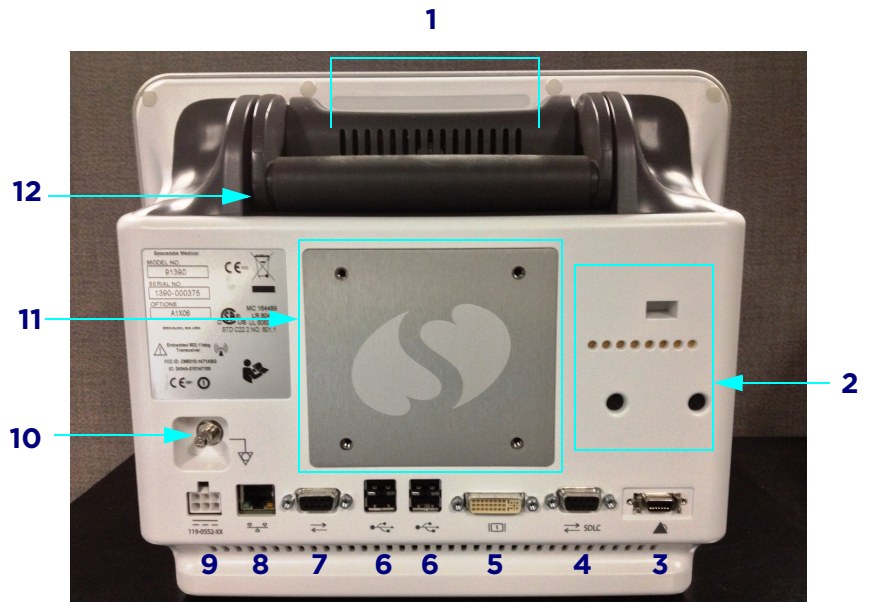

Figure 1-5 Back Panel of Qube*

	Description	Symbol on panel
1	Integrated Alarm Light*	N/A
2	POD Connection such as Capnography Pod.*	N/A
3	Remote Alarm Output - Nurse Alert* Refer to Alarm Relay for option A on page 2-15 for details.	
4	SDLC Ports Refer to SDLC Bus Termination on page 2-15 for details.	
5	Video Output, DVI-D Digital only	
6	USB Ports qty= 4 for option A qty= 2 for options B and C	
7	Serial Port	
8	Ethernet 10/100 Base T Connection	
9	DC Power Input 119-0552-00	 119-0552-XX
10	Equipotential Terminal* used for grounding the monitor	



	Description	Symbol on panel
11	75 mm VESA Mounting Pattern	N/A
12	Handle	N/A

* Not all of the qube configuration options include these items. For more details, refer to [Qube Configuration Options](#) on page 1-4.

Energy Saving Mode (Battery)

The qube has an energy saving mode. Energy saving mode lets the monitor dim after 30 seconds of no interaction. If you enable this mode, do not touch the monitor for 30 seconds to see it dim. The monitor does not dim if you use a mouse with the monitor or an alarm event occurs. Refer to the *XPREZZON and qube System Administration Manual* (P/N 070-2380-xx) for more details.

Signal Strength Indicator

Monitors equipped with option X (an embedded 802.11a/b/g transceiver) are labeled at the factory. A separate label is provided with the option X kit for field installation (Refer to [Figure 1-6](#)).

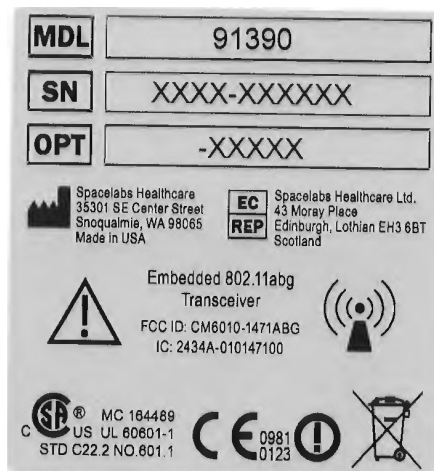

Figure 1-6 P/N 334-6134-01, LABEL,MOD,S/
N,OPT,REG,WIRELESS,91390

	Caution:
	The only other indication for the presence of option X is the wireless field strength icon that shows when the ethernet cable is removed and the wireless option is enabled (Refer to Figure 1-7).

Monitors with wireless network communication show a wireless signal strength indicator while they communicate over the wireless network. To use the wireless feature, disconnect the wired network connector. Not all qube monitors include the wireless option.

The wireless signal strength shows between the **Admit Patient** button and alarm buttons. The signal strength shows a green antenna with vertical bars on a black background. The number of bars show the strength level. One bar is low strength. The strongest signal is five bars. The signal changes to yellow when the network connection is lost. For more information, refer to the *XPREZZON and qube System Administration Manual* (P/N 070-2380-xx).

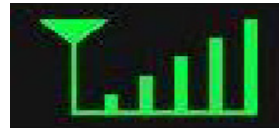

Figure 1-7 Wireless signal strength indication

	Caution:
	Signal strength and radio system congestion can contribute to waveform gaps over the wireless network. Should this be a persistent issue, consult with a Spacelabs Healthcare field service representative.

Batteries and Recharging Batteries

For option A, the monitor uses smart batteries, and at least one battery must be installed for normal operations. If it uses two fully charged batteries in a standard configuration, the monitor operates up to eight (8) hours. With one fully-charged battery in a standard configuration, the monitor operates up to four (4) hours.

The battery icon shows if the batteries are inserted. This icon shows how much charge the batteries have. The icon updates every six seconds and is to the left of the audio icon on the lower-right section of the monitor. Refer to [Table 1-5](#) on page 1-15.

Charge temperature limits are $\leq 80\%$ RH.

The battery must be capable of continuous charge at 12.6 V. To charge the battery, only use a dedicated level II or level III smart battery charger. When you use a level II or level III smart battery charger, the battery requests the appropriate charging voltage and current.

The FULLY_CHARGED bit in the Battery Status is set when the charging current tapers down to under 240 μ A, while charging at 12.6 V.

Notes:

- *The battery life greatly depends on usage, age, and the environment. The battery operating life decreases over time.*



- One battery charges in approximately two hours, and two batteries charge in approximately four hours.

The option B monitor operates for up to four hours with two fully charged batteries and standard configuration. With a single fully charged battery and standard configuration, the monitor operates for up to two hours. The battery is not removable from the monitor.

The option C monitor operates for up to two hours with a single fully-charged batteries and standard configuration. The battery is not removable from the monitor.

Note:

For options B and C monitors, only one battery icon shows on the main screen.

	Caution:
	<p>The qube monitor and smart rechargeable Li-Ion batteries and cells do not overheat, they have internal protection devices. Overexposure to heat will activate one of these devices and may permanently disable the battery. If this happens, contact Spacelabs Healthcare to purchase a replacement battery.</p>

To change batteries without interruptions while operating on battery power

- 1 If operating on top battery (battery A), remove lower battery (battery B).
- 2 Install new battery (battery C) into the lower battery slot.
- 3 To make sure that the operation of the new battery is correct, look at the battery indicator lights (Refer to [Table 1-5](#) on page 1-15).
- 4 Remove battery A. Replace it with another new battery.

Battery Power Level

Extended use of the batteries depletes the battery power. To prevent patient data loss, the qube monitor watches the battery power level that remains. As power gets low, the monitor warns the user about low battery power and inhibits the use of the internal recorder to extend run time.

Table 1-5 Battery power level messages and tones



A green color on the battery icon shows the current charge level of the battery. A yellow or red color shows that the battery power is at a critically low level. If the battery power is critically low, recharge the battery.



Table 1-5 Battery power level messages and tones

A dark gray outline around a solid black battery icon shows that a battery slot is empty. After you install a battery into the slot, the battery icon shows a white outline and the current charge level of the battery..



Power level (one battery)	Power level (two batteries)	Recorder attached	Warning description	Audible tones	**Approximate time before device shuts down
11%	6%	Yes	The message shown lets you know that the recordings stop.	soft	30 minutes
6%	3%	Yes	Yellow flashing battery icon is shown. Message shown lets you know the recordings are stopped. 	soft	15 minutes
4%	2%	With or without recorder	Red flashing battery icon is shown. Message shows that the battery power level is critically low. 	loud	10 minutes

*** Time can be shorter or longer depending on the battery performance.*

Architecture

The basic internal architecture, or Printed Circuit Board Assembly (PCBA), of the qube monitor, is shown in the System Block Diagram (Drawing 1, Sheet 1). Refer to the drawings section of this manual for more information.

The hardware for the monitor has the following features built around the Microprocessor Controller (MPC) MPC8270:

- 10/100BaseT Ethernet
- 266-MHz maximum CPU speed
- 66-MHz system bus for memories
- 32 MB Flash, 64 MB of SDRAM, and 2 MB SRAM
- 3.3-V logic design
- PCI2.2 at 33 MHz



- USB support (USB2)
- Optional mini-PCI Wireless interface for 802.11a/b/g devices
- External Video (Digital DVI)
- 5-wire resistive touchscreen
- Barcode Reader support (through USB port)
- Optional Remote IR Keypad support: option A
- Multilevel/Multicolor alarm indicator: option A

Directory of Keys

For a comprehensive directory of keys and explanations, refer to the *XPREZZON and qube System Administration Manual*.





Setup

Unpack the Monitor

Standard contents in the box includes:

- 91390 monitor
- Country-specific power cord
- Battery (option A: one, second is optional)
- External DC power supply

Make sure that there is a packing list for optional accessories. Keep at least one shipping box and its packing materials in case you must return items, or if the monitor requires factory service.

Notes:

- *When you remove items from the shipping containers, make sure that you remove ALL components from each container.*
- *To determine the contents, refer to the packing list for your individual order.*
- *When you receive the equipment, complete a detailed inventory to make sure that the equipment you received matches your order. This inventory must include serial numbers, model numbers, and all options and cables received. Carefully examine these items for shipping damage. If you find any damage, immediately notify the freight company and Spacelabs Healthcare.*



	Warning:
	<ul style="list-style-type: none">• <i>The qube monitor and smart rechargeable Li-Ion batteries and cells do not overheat, they have internal protection devices. Overexposure to heat will activate one of these devices and may permanently disable the battery. If this happens, contact Spacelabs Healthcare to purchase a replacement battery.</i>• <i>Failure to properly configure this device prior to network connection may alter network time or corrupt patient data.</i>• <i>Do not mount the monitor or docking station directly above the patient.</i>

	Caution:
	<ul style="list-style-type: none">• <i>If liquid spills onto the docking station, make sure that the docking station is checked by service staff before you use it again.</i>• <i>Observe precautions for handling electrostatic-sensitive devices!</i>

Notes:

- *Before you touch electrostatic-sensitive electronic components, follow proper anti-static procedures, including the use of an ESD wrist band and mat. An electrostatic discharge from your fingers can permanently damage electronic components and cause latent failures.*
- *All static-sensitive electronic components are packaged in static-shielding bags. Keep the bag in case you must repackage the component to store it or return it to Spacelabs Healthcare for any reason.*
- *For options B and C, the battery switch must be set to ON prior to use.*

Display Assembly

Display features:

- LCD TFT Display, 12.1" with backlight control
- 5 Wire Resistive Touch screen
- RED, YELLOW, and CYAN LED bars: options A and B
- Remote control IR receiver: option A
- Power and Battery status indicators (LEDs)
- Power switch





Input/Output Connections (Internal and External)

This section defines the I/O connections.

The back panel includes:

- DC Input Power connector
- SDLC (Flexport) connector
- Pod interface connector (SDLC protocol): options A and B
- Remote Nurse Alert connector: option A
- Second display connector (DVI-D)
- RS232 serial connector
- USB ports: Four for option A. Two for options B and C. Ethernet 10/100 base T, RJ45 connector.

	Warning:
	<p><i>Data interface connectors on this device are Ground (Earth) referenced!</i></p> <ul style="list-style-type: none"> - <i>Only connect this device to other medical equipment suitable for use in the Patient Vicinity.</i> - <i>Check Ground (Earth) Leakage after connecting data interface cables.</i>

The left side supports the module slot. The right side accommodates two lithium batteries and the recorder.

Pod Interface Connector - 8 CONTACT PADS for options A and B

The pod interface SDLC I/O connector (P300) is on the back panel of the monitor. The pinout for this connector is designed as follows:

Table 2-1 Pinout for Pod Interface Connectors

Pin #	Function
PIN 1	SDLC_DAT+
PIN 2	SDLC_DAT-
PIN 3	SDLC_CLK+
PIN 4	SDLC_ CLK +
PIN 5	GROUND
PIN 6	+5 VDC
PIN 7	+12 VDC
PIN 8	-12 VDC

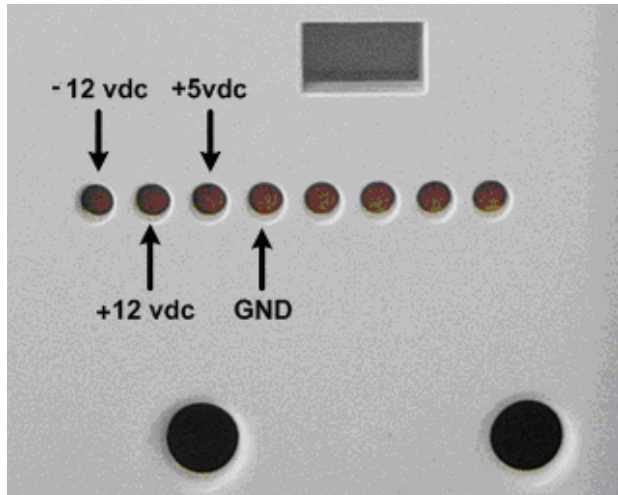

Figure 2-1 Voltage test points on pod connector

SDLC I/O Connector - DB9 Female

The Flexport SDLC I/O connector is on the back panel. The SDLC clock frequency is approximately 2 MHz. Docked, (P506) becomes the SDLC I/O. This interface is electrically compatible with the EIA-RS485/RS422 standard. The communications protocol is derived from the IBM Synchronous Data Link Control specification, and uses its Non-Switched Multipoint Half-Duplex configuration. This interface is compatible with all of Spacelabs Healthcare Flexports. The CPU board always provides the SDLC clock. The SDLC clock frequency is 3.7847 MHz ±100 ppm. The pinout for this connector is as follows:

Table 2-2 Pinout for external SDLC connector

Pin #	Function	Image
PIN 1	RTN	<p style="text-align: center;">front view</p>
PIN 2	SDLC DATA +	
PIN 3	SDLC DATA -	
PIN 4	+ 5V	
PIN 5	+ 12V	
PIN 6	SDLC CLK +	
PIN 7	SDLC CLK -	
PIN 8	-12V	
PIN 9	RTN	



Remote Nurse Alert Connector - 14 Pin for option A

The Remote Nurse Alert connector is primarily designed to provide a contact closure to the outside world to indicate an alarm condition. The nurse alert output provides +12V, return and three sets of relay contacts. There is one set of relay contacts for each of the three alarm levels. Each set of relay contacts consists of a common normally open (NO) and normally closed (NC). Each contact is able to carry at least 150 mA continuous.

	Warning:
	<p>Data interface connectors on this device are Ground (Earth) referenced!</p> <ul style="list-style-type: none"> - Only connect this device to other medical equipment suitable for use in the Patient Vicinity. - Check Ground (Earth) Leakage after connecting data interface cables.

The pinout for this connector is as follows:

Table 2-3 Connector Pinouts

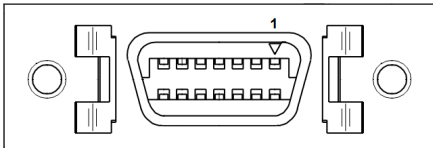
Pin	Alarm Circuit	Meaning	Image
1	Alarm 0 (high priority)	Common	
2		Normally Closed	
3		Normally Open	
4	GND		
5	Alarm 1 (medium priority)	Normally Closed	
6		Normally Open	
7		Common	
8	GND		
9	+12 V, 140 μA		
10	GND		
11	GND		
12	Alarm 2 (low priority)	Normally Open	
13		Common	
14		Normally Closed	



DVI Digital Video Output Connector - 29 PIN DVI-D

This DVI-D video connector (P207) is an output to an optional secondary display. The voltage levels on these connectors are compatible with the EIA-RS343A standard. The video timing supports the qube monitor itself. The pinout for this connector is as follows:

Table 2-4 Pinout for External DVI Connector

Pin #	Function	Pin #	Function	Image
PIN 1	TX2N	PIN 17	TXON	
PIN 2	TX2P	PIN 18	TXOP	
PIN 3	RTN	PIN 19	RTN	
PIN 4	NC	PIN 20	NC	
PIN 5	NC	PIN 21	NC	
PIN 6	DDC_CLK	PIN 22	RTN	
PIN 7	DDC_DAT	PIN 23	TXCP	
PIN 8	NC	PIN 24	TXCN	
PIN 9	TX1N	PIN C1	NC	
PIN 10	TX1P	PIN C2	NC	
PIN 11	RTN	PIN C3	NC	
PIN 12	NC	PIN C4	NC	
PIN 13	NC	PIN C5A	RTN	
PIN 14	+5VDC	PIN C5B	RTN	
PIN 15	RTN	PIN 31	SHIELD	
PIN 16	NC	PIN 32	SHIELD	

	Warning:
	<p>Only connect to an approved medical device.</p> <ul style="list-style-type: none"> - Common computer equipment may exceed safe leakage current limits in the patient vicinity. - Check leakage currents after equipment is interconnected.



DC Power Input Connector

There is one DC Power input connector (P204), on the back of the unit. The DC Power Input connector mates to an external AC/DC converter supply. The pinouts for this connector are as follows:

Table 2-5 Pinout for the DC Power Input Connector

Pin #	Function	Image
PIN 1	Ground	
PIN 2	+ V	
PIN 3	+ V	
PIN 4	RTN	
PIN 5	RTN	
PIN 6	Ground	

Serial I/O Connector - DB9 Female

The Serial I/O connector is on the back of the unit and provides RS-232 access to the CPU Board. This interface conforms to the EIA-RS232 standard. The baud rate and the number of start, stop, and parity bits are software programmable.

This connector is also used to support the Sysgen Data Key function, which controls access to menus to enable and disable qube options. The pinouts for this connector are as follows:

Table 2-6 Pinout for Serial Port

Pin #	Function	Image
PIN 1	CD	<p style="text-align: center;">front view</p>
PIN 2	RXD	
PIN 3	TXD	
PIN 4	DTR	
PIN 5	RTN	
PIN 6	DSR	
PIN 7	RTS	
PIN 8	CTS	
PIN 9	NC	



USB Connectors (4 for option A, 2 for options B and C)

There are two dual USB type-A connectors which allow connection of up to 4 USB devices. The type of USB devices supported are limited to keyboards, mice, barcode readers, and USB flash drives. Ports are compatible with USB 2.0. The pinouts for these connectors are as follows:

Table 2-7 Pinout USB Connectors

Pin #	Function	Image
Port A Top	PIN A1	A: VBUS (+5V)
	PIN A2	A: DATA-
	PIN A3	A: DATA+
	PIN A4	A: RTN
Port B Bottom	PIN B1	B: VBUS (+5V)
	PIN B2	B: DATA-
	PIN B3	B: DATA+
	PIN B4	B: RTN

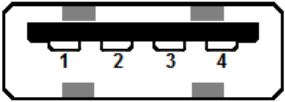

10/100BASE-T Ethernet Connector - RJ 45

The 10/100 Base-T Ethernet connector is on the back of the unit. The Ethernet interface is designed to conform to the IEEE802.3 standard. The monitor is designed to auto-detect and switch between 10 Base-T and 100 Base-Tx. Pinouts for this connector are as follows:

Table 2-8 Pinout 10/100 Base-T Ethernet Connector

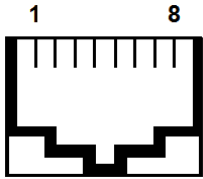
Pin #	Function	Image
PIN 1	TD +	
PIN 2	TD -	
PIN 3	RD+	
PIN 4	TCT (+3.3 VDC)	
PIN 5	RCT	
PIN 6	RD-	
PIN 7	N/C	
PIN 8	CHS	



Power LED

The monitor has a recessed momentary push-button switch on the right side to toggle the unit between ON and OFF. To turn OFF the monitor, hold the On/Off switch for three seconds. When you power off the monitor, it also turns the power off to all devices drawing power from the monitor, such as keyboards, mice, barcode readers, Flexports, Pod interfaces, and printers.

If you switch the power off, it does not stop the charging of batteries when connected to mains. Refer to [Battery charger and AC/DC power indicators](#) on page 1-11 for details.

Battery Status LED

Refer to [To change batteries without interruptions while operating on battery power](#) on page 1-15 for details.

Alarms

For information on alarms configuration and alarm tones, refer to the *XPREZZON™ and qube™ System Administration Manual*.

Cables

Maximum Cable Lengths

The list of cables that follow are limited to the indicated maximum length:

- **SDLC Cable** — 40 feet (12.2 m) maximum (total length from the monitor to the last device on the bus). For longer SDLC cable runs, contact your local customer service representative.
- **DVI-D Video Cable** — 16 feet without a repeater. For distances greater than 16 feet, a repeater may be required in order to guarantee signal quality.
- **Ethernet cable (10/100BaseT)** — 328 feet (100 m) maximum.

SDLC External Devices

External devices (for example, Flexport® system interfaces) can be connected to the SDLC bus. In this context, the term *external* means connected to the SDLC bus by cable through an external connector. This is in contrast to modules, which are connected by inserting them into a module housing.



	<p>Warning:</p> <p><i>Unreliable system operation will occur if the SDLC bus is not correctly terminated or the maximum cable length is exceeded. Flexport interfaces must be attached to the most distal module housing on the SDLC bus.</i></p>
--	--

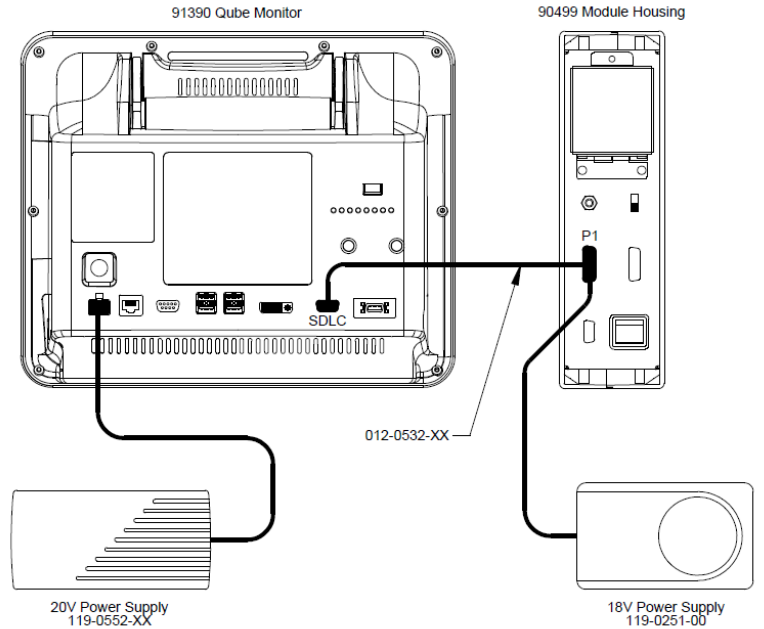

Figure 2-2 Qube Option A Connected to the 90499 Module Housing

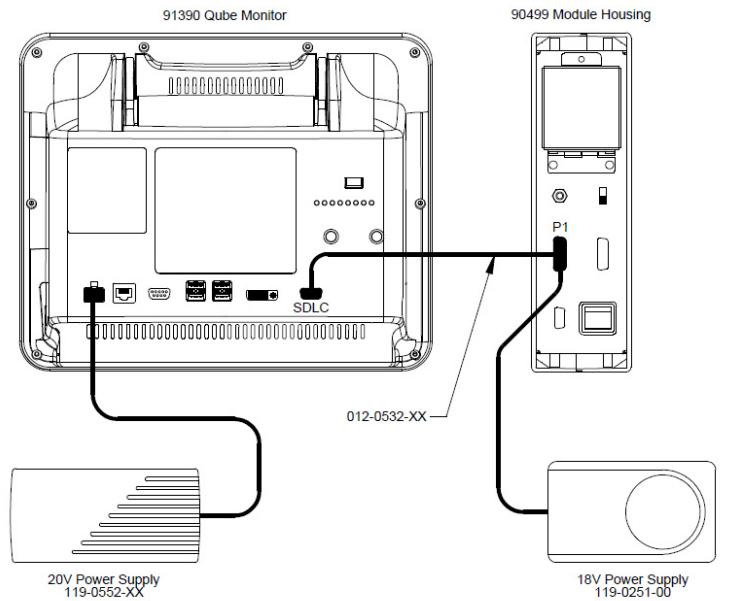

Figure 2-3 Qube Option B Connected to the 90499 Module Housing

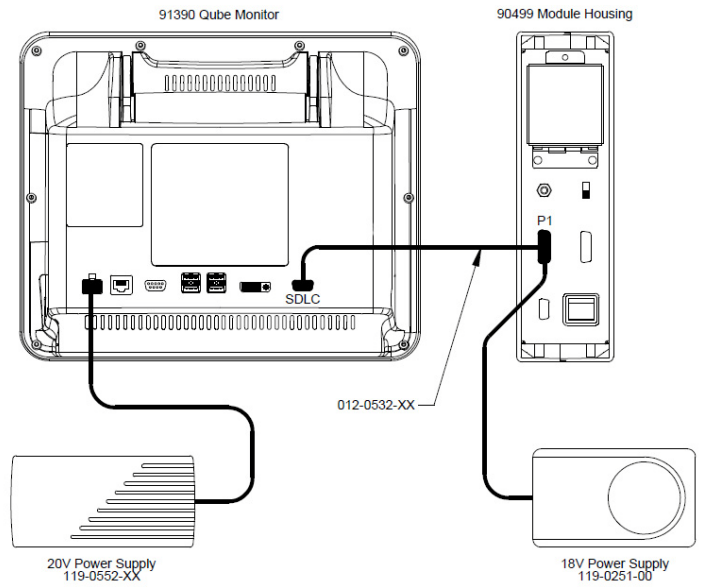

Figure 2-4 Qube Option C Connected to the 90499 Module Housing

If no supplementary module housings are present (not including the module slot on the monitor), then directly connect external devices to the SDLC connector on the monitor (refer to [Figure 2-5](#), [Figure 2-6](#), or [Figure 2-7](#) depending on your monitor option).

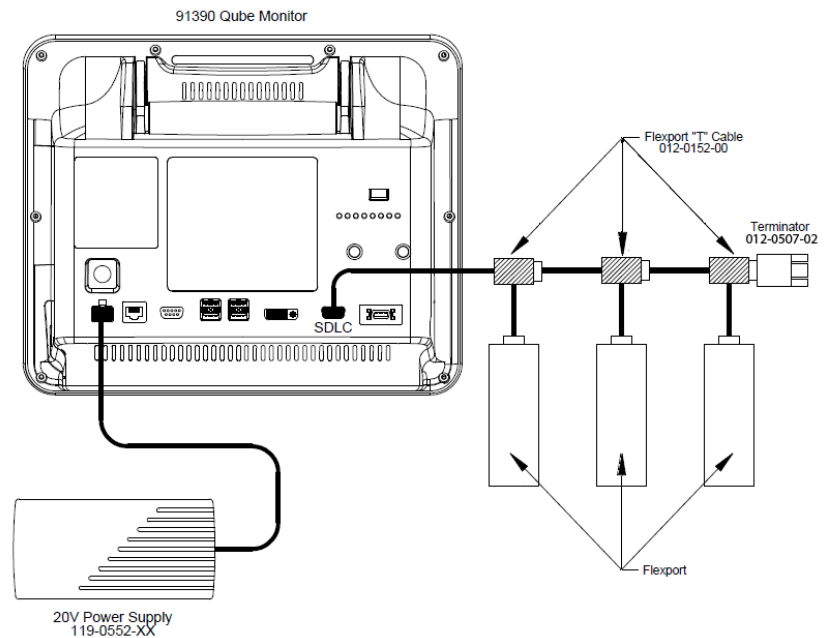

Figure 2-5 Qube Option A Connected Directly to Flexports

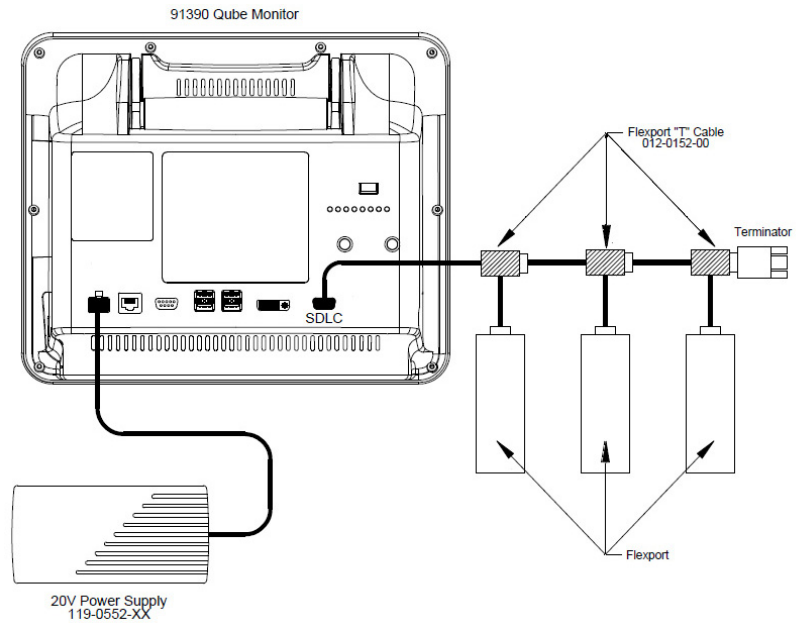

Figure 2-6 Qube Option B Connected Directly to Flexports

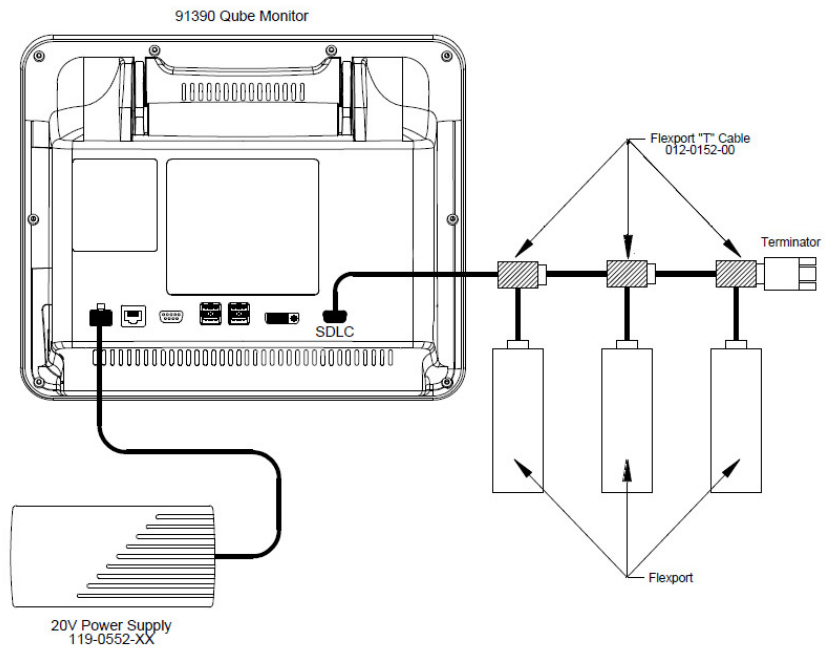

Figure 2-7 Qube Option C Connected Directly to Flexports

If one or more supplementary module housings are present, Flexport devices are connected to connector J2 on the 90499 supplementary module housings. Refer to the *Module Housing Service Manual* (P/N 070-0680-xx) for more information.

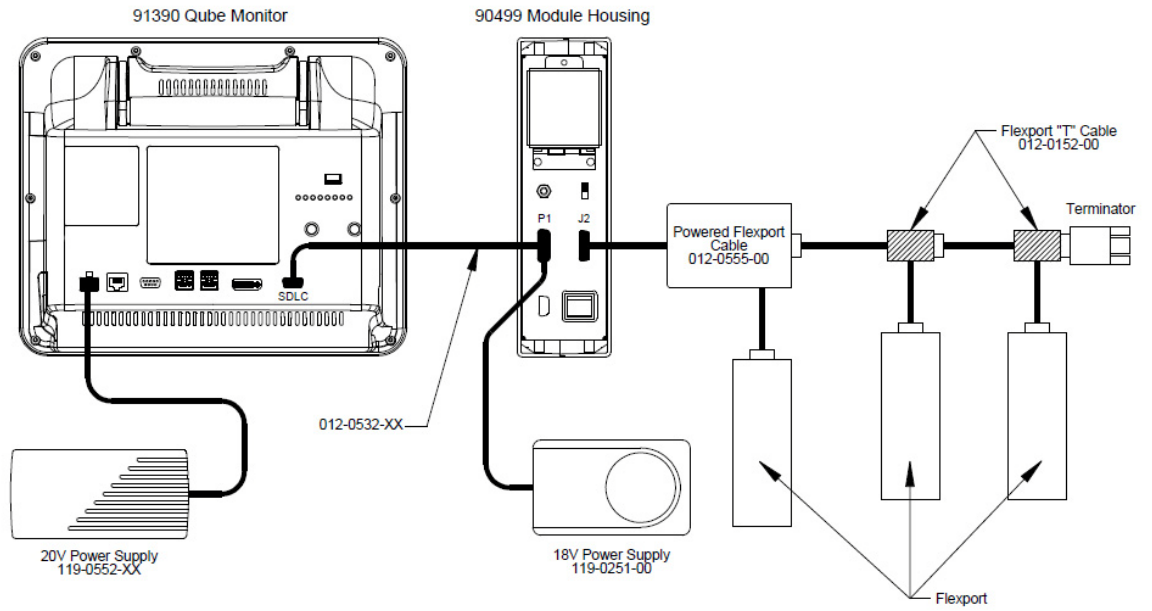

Figure 2-9 Qube Option B Connected to 90499 Module Housing and Flexports

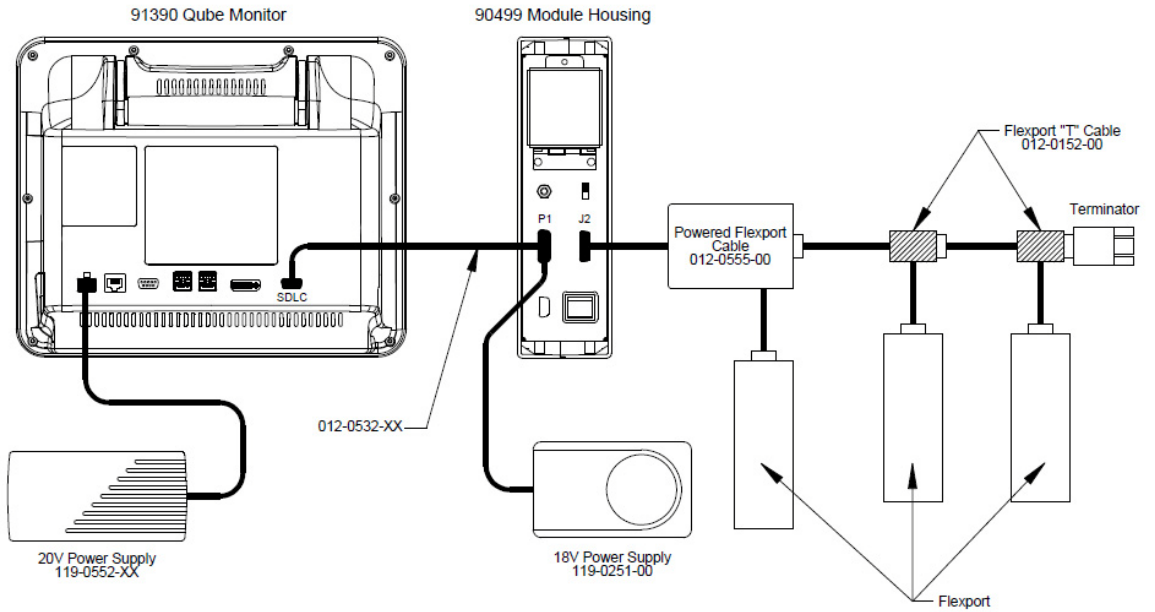



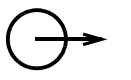

Figure 2-10 Qube Option C Connected to 90499 Module Housing and Flexports



SDLC Cable Interconnection

To ensure Electromagnetic interference (EMI) compliance, the appropriate Spacelabs Healthcare 9-pin connector must be used. Refer to the *Module Housing Service Manual* (P/N 070-0680-xx).

SDLC Bus Termination

The SDLC bus must be properly terminated for correct operation. If no external devices (for example, Flexports or multigas analyzers) are connected, proper termination of the SDLC bus is accomplished automatically. If external devices are connected, the switch on the module housing farthest from the monitor must be set to the terminated ( position. All others must be set to the non-terminated ( position. The SDLC clock and data signals are switched by the terminator switches and are not present “downstream” of any switch set to the  position.

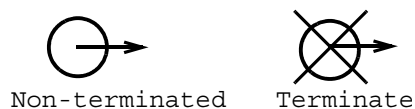



Figure 2-11 Terminator switch settings

Because bus termination is handled by setting the switches appropriately, an external terminator is only required when external devices are connected.

If external devices are connected, an external cable terminator is required to terminate the SDLC bus. This must be installed at the end of the SDLC bus (following the last external device). In this case, all module housings must have their switches in the  position.

Note:

Flexports require a powered Flexport cable (P/N 012-0555-00) when used with the 90499 module housing. SDLC data is only passed along to the external device or devices when the terminator switch (SW2) is in the  position.

Alarm Relay for option A

Alarm output signals are available at the Nurse Alert () connector instantaneously when an alarm occurs. [Table 2-3](#) describes the connector pinouts for remote alarms. [Figure 2-12](#) on page 2-16, [Figure 2-13](#) on page 2-16, and [Figure 2-14](#) on page 2-17 illustrate the circuits for each alarm function.

	<p>Warning:</p> <p>Data interface connectors on this device are Ground (Earth) referenced!</p> <ul style="list-style-type: none"> • Only connect this device to other medical equipment suitable for use in the Patient Vicinity. • Check Ground (Earth) Leakage after connecting data interface cables.
--	--

	<p>Warning:</p> <p>For operational safety and reliability, the following relay contact ratings MUST NOT BE EXCEEDED:</p> <ul style="list-style-type: none"> • Current = 250 ma • Voltage = 28 V AC/DC
--	---

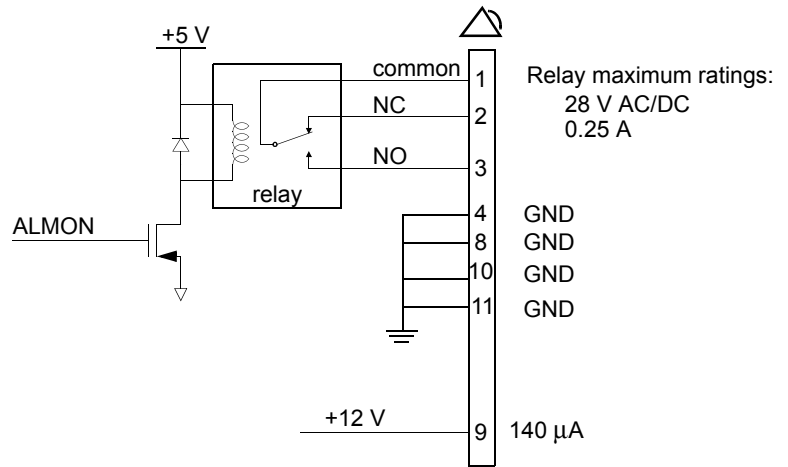

Figure 2-12 Alarm 0 (High Priority) Relay Schematic

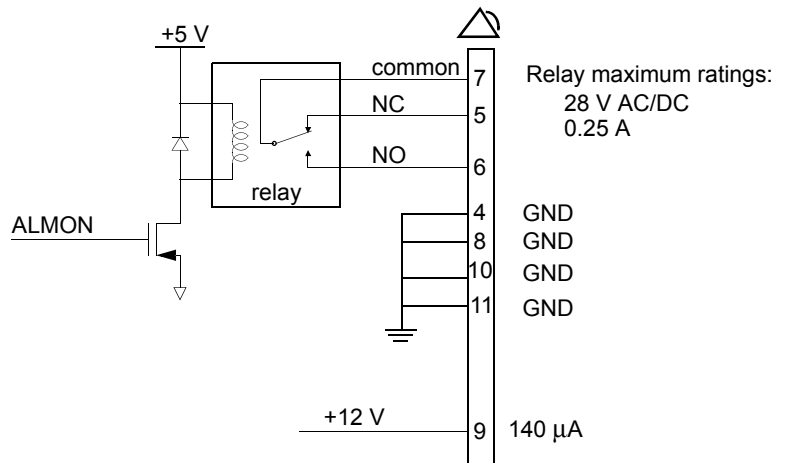

Figure 2-13 Alarm 1 (Medium Priority) Relay Schematic

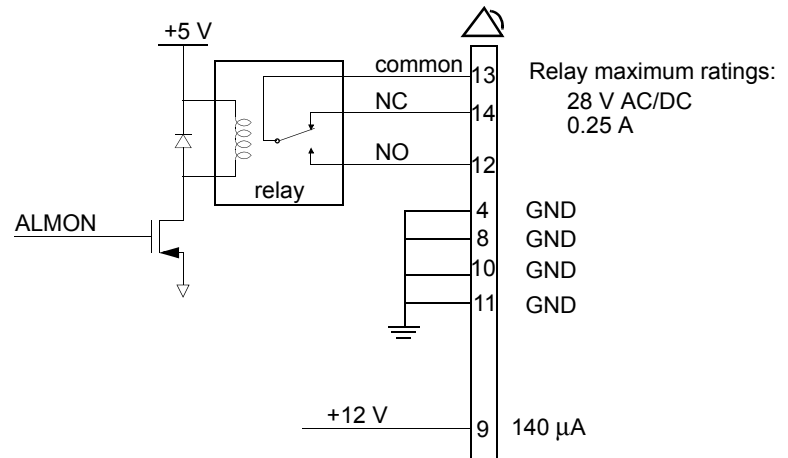

Figure 2-14 Alarm 2 (Low Priority) Relay Schematic

Power-ON Test

Each time the monitor is powered ON:

- Diagnostic information displays for approximately 17 seconds.
- Monitor keys display on the right side of the screen.

The monitor is now ready for normal operation.

Configure the Monitor

Privileged Access Menus

The **Privileged Access** button in the **Monitor Setup** window provides access to several levels of configuration. These configuration levels are described in the sections of the *XPREZZON and qube System Administration Manual*.

Refer to *XPREZZON and qube System Administration Manual* (P/N 070-2380-xx) for the **Clinical** and **Biomed Level** menu structure.





Theory

CPU PCB

The CPU PCB combines the CPU core, power supplies, Li-Ion battery charger, touchscreen interface, USB subsystem, ATI ES1000 graphics processor and all other I/O interfaces (refer to [Figure 3-1](#) on page 3-1). The Freescale MPC8270 running vxWorks Real Time Operating System (RTOS) interfaces via 64-bit local bus to Flash, SDRAM, SRAM, and Non-Volatile Memory (NVRAM). The application code is stored in FLASH and loaded into SDRAM at run time. NVRAM is used to store monitor configuration data and backed up by an internal battery in the IC and also provides a real-time clock function.

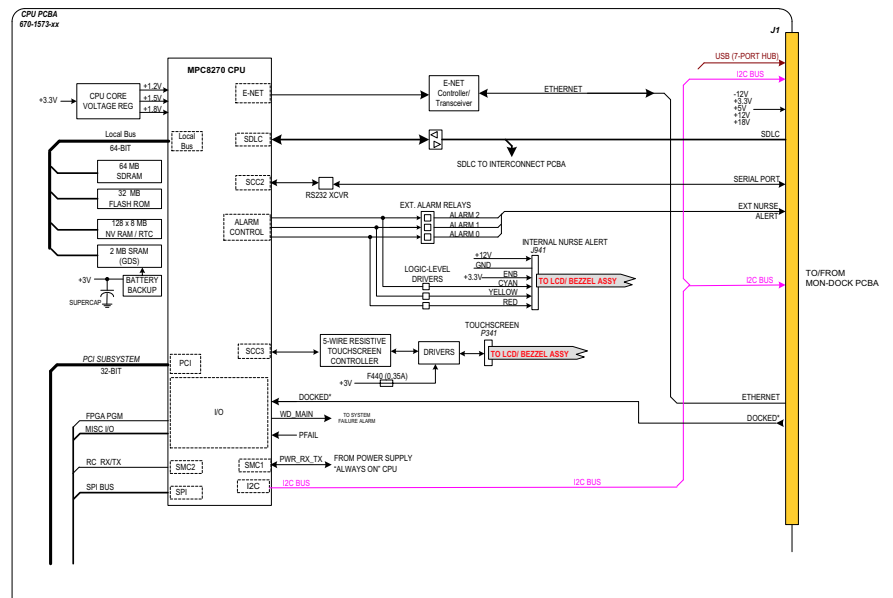

Figure 3-1 CPU Core Processing

A PCI bus is used to communicate to the ATI / ES1000 GPU, USB host controller, and optional wireless card (refer to [Figure 3-2](#) on page 3-2).

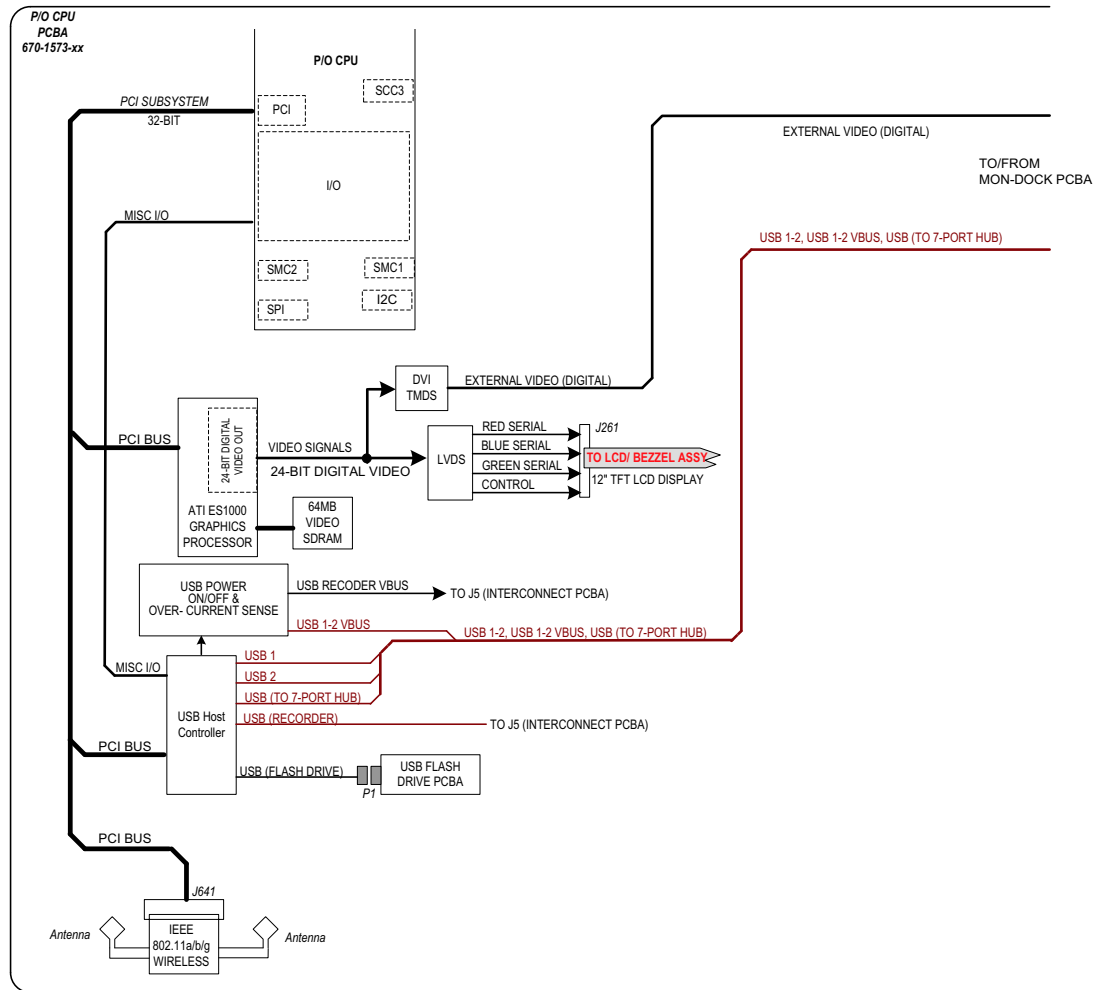

Figure 3-2 PCI Subsystem

The USB host controller has 5 USB ports and interfaces to:

- USB port 1 - USB Flash Drive
- USB port 2.3 - becomes external USB1, USB2
- USB port 4 - drives USB Hub on Mon-Dock PCBA
- USB port 5 - drives recorder.

If replacement is ever required, an internal flash drive provides bulk memory and has special formatting requirements.

An on-board FPGA is used for SDLC Clock generation, and audio clocks 11.3541 MHz (+/-1%). It is also used for SPI to I2S serial bus conversion to interface the MPC8270 to the audio codec. The FPGA is also responsible for decoding the IR remote control signals when used with the 90360-01 remote control.

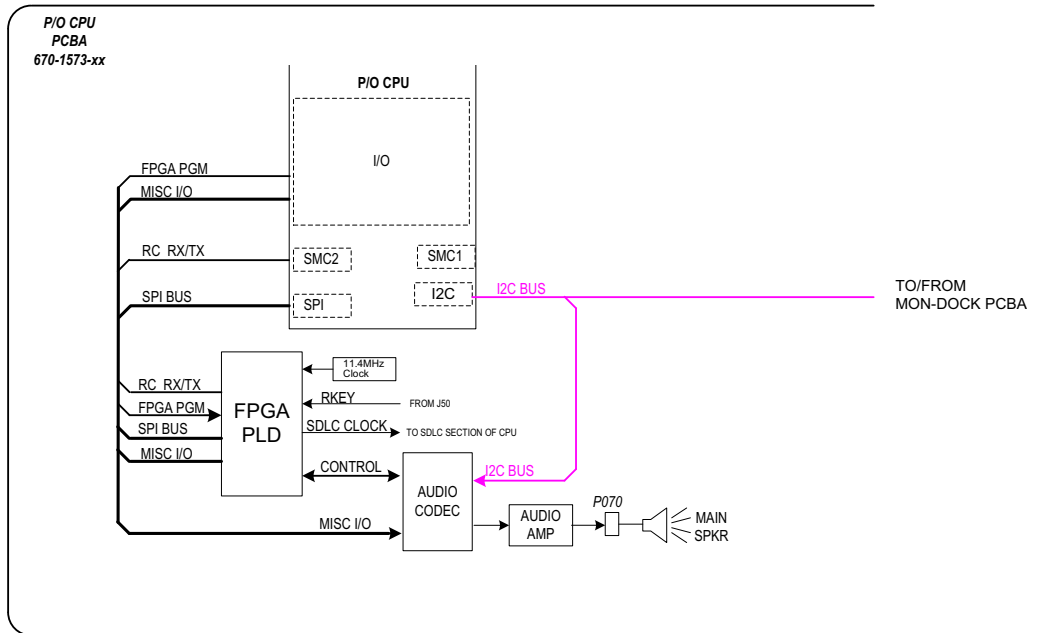

Figure 3-3 FPGA Subsystem

Battery Charger and Power Supply Subsection (on CPU PCB)

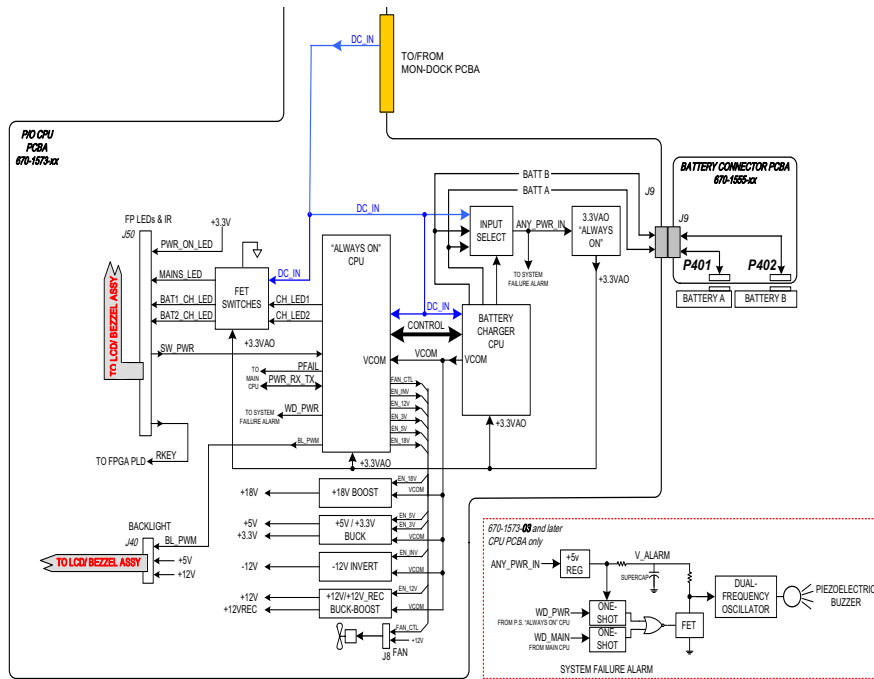

Figure 3-4 Power Supply Subsystem

The Power Supply and Battery Charger subsystem (refer to **Figure 3-4**) consists of several subsystems:

- Always On (AO) MCU that provides ON/OFF control
- Battery management / charging control
- Voltage monitoring
- PWM for backlight
- Power sequencing
- Unit shutdown warning (PFAIL)
- Internal temperature monitoring
- Control of +12V, +5V, +3.3V, -12V power supplies

To show and monitor the supply voltages, open the **Biomed** menu, click the **System Info** tab, then select the **Analog** key. If out of range conditions are presented, voltages are checked at power-on, and during run time and events are logged.



The LTC1960 battery charger IC interfaces with the AO MCU. It is responsible for load switching between AC and battery or batteries, and direct communication via SMBUS protocol to the Li-Ion smart batteries. The IC is also responsible for charging the batteries. Refer to the battery section for more information on batteries.

For 670-1573-03 CPU PCBAs and higher, a high priority technical alarm has been added. The AO MCU triggers a technical alarm in the following events:

- Out of tolerance voltages on the +3.3V, +5V, +12V, and -12V supplies
- No host CPU MPC8270 response
- If the AO MCU also fails to update the watchdog circuit

The technical alarm is a redundant alarming circuit that does not use the main CPU audio. This circuit can derive power from the external power supply, battery, or supercap incorporated in the circuit. The safety circuit sounds if: the unit is unplugged from AC and no battery is present, or if the unit is operating on battery and the battery is depleted.

Li-Ion Batteries

If either the charger or host device fails to function correctly, electronic circuitry is permanently connected within the battery pack to prevent damage. If an illegal current source is placed across the battery terminals or an illegal load is connected, the circuitry also protects the battery. Redundant levels of protection have been implemented (the primary protection levels are auto-resettable and the secondary are non-resettable).

If any cell voltage $\geq 4300 \mu\text{V}$, the primary protection circuit prevents the battery from charging. It allows charging again once all cell voltages are $\leq 4150 \mu\text{V}$. If any cell voltage $\geq 4.45 \text{ V} \pm 0.05 \text{ V}$ by blowing a power path logic fuse, the secondary protection circuit prevents the battery from charging. The fuse is non-resettable, which renders the battery pack nonfunctional.

The primary protection circuit also provides over-temperature protection and prevents the battery from charging at temperatures $\geq 54^\circ \text{ C}$. Then, once the battery temperature has cooled to $\leq 45^\circ \text{ C}$, it again allows charging.

The primary protection circuit also provides continuous over-current protection and prevents the battery from charging at $\text{Current}() \geq 4.25 \text{ A}$. Then, once the $\text{Average Current}() \leq 200 \mu\text{A}$ for 70 sec, the battery will retest the overcurrent condition, and again allow charging.

The primary protection circuit prevents the battery from being further discharged once any cell voltage reaches $\leq 2500 \mu\text{V}$. Then, once all cell voltages are $\geq 3000 \mu\text{V}$, it allows discharge again.

The primary protection circuit also provides over-temperature protection and prevents the battery from discharging at temperatures $\geq 75^{\circ}\text{C}$. Then, once the battery temperature has cooled to $\leq 65^{\circ}\text{C}$, it allows discharging again. If the battery reaches 85°C for any reason, the secondary protection circuit blows the in-line power path logic fuse. The fuse is non-resettable, which renders the battery pack nonfunctional.

The primary protection circuit also provides continuous over-current protection and prevents the battery from discharging at $\text{Current}() \leq -6.25\text{ A}$. Then, Once the $\text{Average Current}() \geq -200\ \mu\text{A}$ for 70 sec, the battery will retest the overcurrent condition, and again allow discharging.

If a short-circuit is placed across the battery + / - terminals, the primary protection circuit prohibits the discharge of the battery. When the $\text{Average Current} \geq -1\ \mu\text{A}$ for 70 sec, the battery retests the short-circuit condition, and again allows discharging. The pack is designed to withstand reasonable in-rush currents without resetting the electronics and without interrupting the discharge cycle.

A thermal fuse is fitted in series with the charge/discharge path to protect the battery from over temperature. This device goes open circuit if the cell case temperature reaches the fuse's temperature rating of 93°C ($+0^{\circ}\text{C}$, -5°C). The fuse cannot be reset, which renders the battery pack nonfunctional.

A current slow-blow fuse is assembled in series with the battery pack to protect the battery pack against abusive overcurrent overload. The hold current is rated at 12 A for 4 hours (minimum @ 25°C). The fuse is non-resettable, which renders the battery pack nonfunctional.

	<p>Warning:</p> <p><i>Make sure that a functional Li-Ion battery SLHC P/N 146-0142-xx is installed in the unit as part of safety checks. Gas, BISx, and SvO₂ modules do not have battery backup of alarm settings, and alarm settings reset to defaults if monitor power is interrupted for more than three minutes.</i></p>
---	---



Battery Switch PCBA for Options B and C

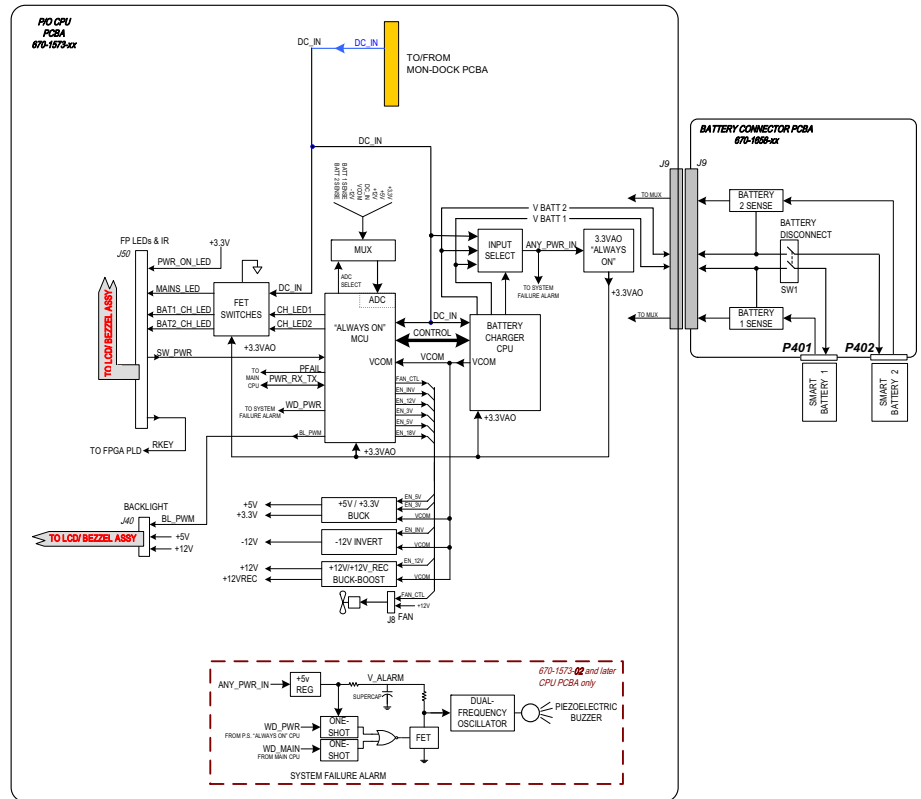

Figure 3-5 Battery Switch PCBA for Options B and C

The batteries ship pre-installed for qube options B and C and require unit disassembly for replacement. The batteries used on these options are the same type of Li-Ion smart battery used on option A, but have a lower capacity and are physically shorter. The 670-1658-xx battery board used on options B and C includes a small micro switch mounted on the bottom left of the monitor ([refer to Figure 3-6](#)).

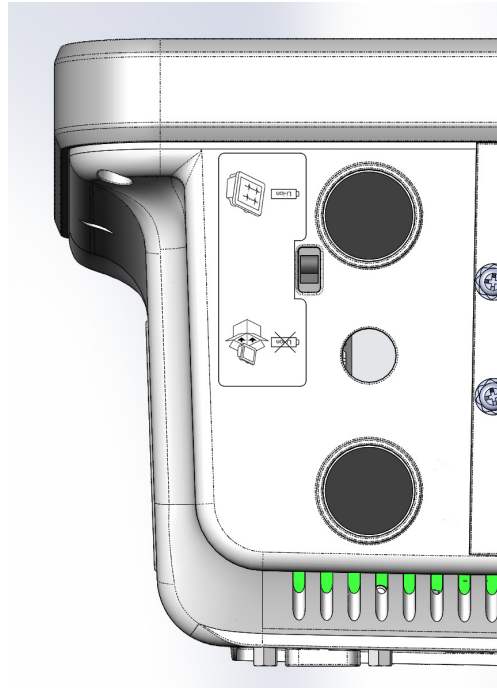

Figure 3-6 Battery Switch on Bottom Left of the Monitor

This switch is designed to remove the batteries from the circuit during shipment and recessed to prevent inadvertent contact from changing its position. There are a few active components on the options B and C battery board used to switch the battery V+ lines and communication line to host with a single switch. These signals are communicated to the power supply MCU which control battery charging and front screen icon indications. The battery switch has symbols to show when to turn the switch on and off. Turn the switch off for shipping and service (refer to [Figure 3-7](#)). Turn the switch to on for regular operation (refer to [Figure 3-8](#)).

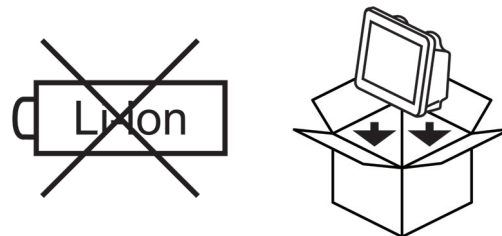

Figure 3-7 Battery Switch Off Symbol

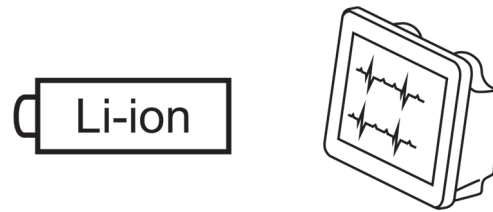

Figure 3-8 Battery Switch On Symbol

Monitor Docking PCBA and Connector PCBA

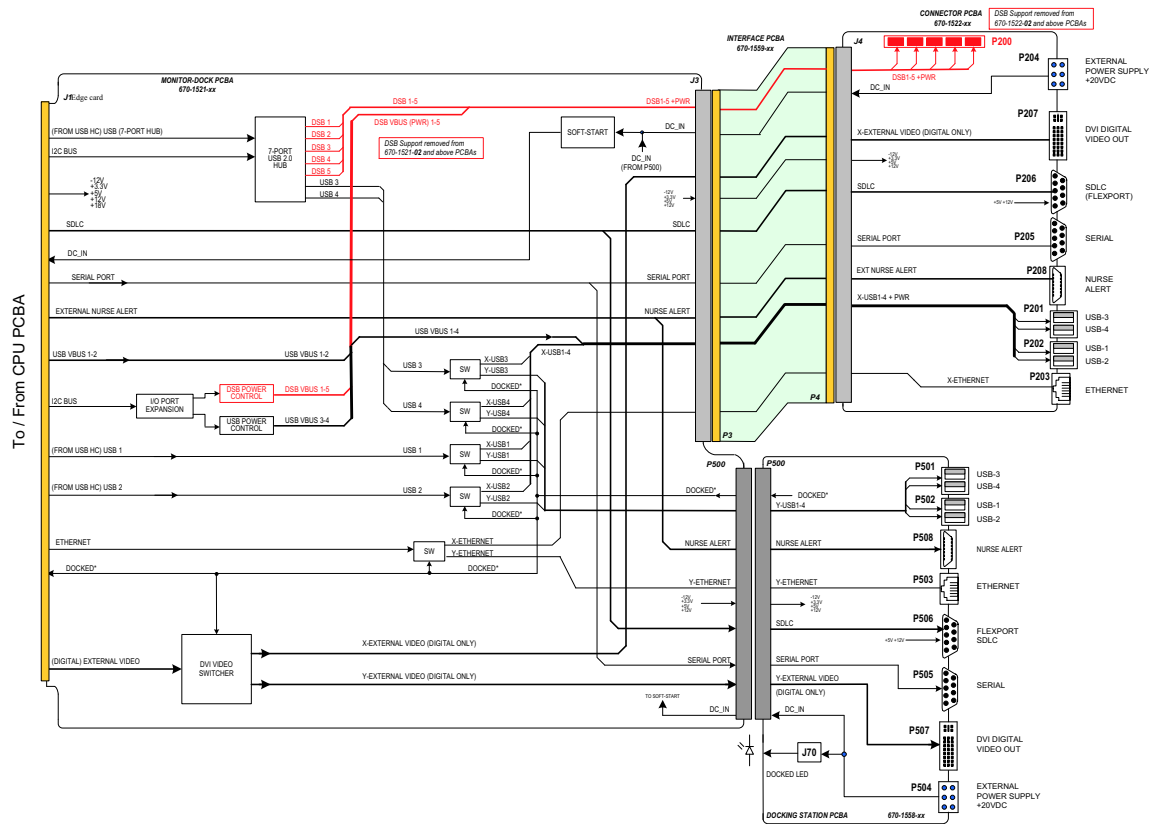

Figure 3-9 Monitor Docking PCBA and Connector PCBA

The monitor docking PCB has a docking connector for interface to a docking station (refer to [Figure 3-9](#)). All I/O connectors and power are routed on this board. They are available to either the docking station when docked, or presented at the rear of the monitor when not docked. High-speed signals like Ethernet, DVI and USB are switched so the unused stubs when docked do not affect the signal impedance.

Input power from the external power supply is routed through this board for both the monitor and docking station inputs. It also runs through a soft start circuit to limit in-rush current. A 7-port USB Hub is found on the docking station board to expand out USB / DSB.

The connector board is a board with all the I/O connectors on it. All the I/O signals from the monitor dock PCBA are routed to the connector board using a small interconnect PCB rather than cables. This increases robustness and ease of service.

Front Bezel Assembly

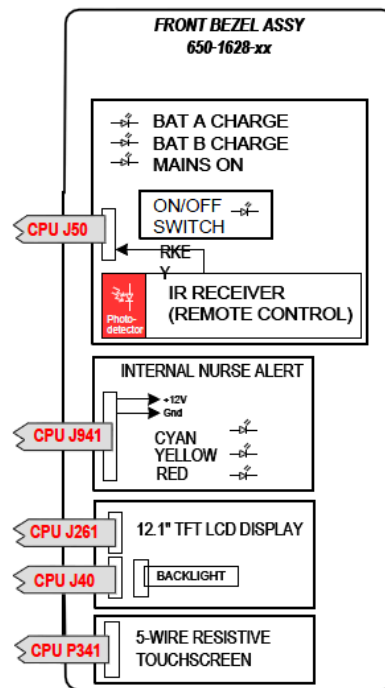

Figure 3-10 LCD Display Assembly for Option A

Note:

Options B and C do not have the IR Receiver. Option C does not have the internal nurse alert,

The front bezel assembly contains:



- 5-wire resistive touch panel
- LCD display
- Backlit ON/OFF button
- Integrated alarm light
- Battery status / AC connected LED's and the IR remote keypad receiver. The screen is wrapped in an aluminum frame and powder coated for increased strength. The presentation of alarm lights through the touch panel is patent pending.

All battery status and AC connected status comes from the CPU PCB. The state of alarms to enable red, yellow, or cyan alarm lights for high, medium, and low priority alarms also come from the CPU PCB. The ON/OFF switch state is de-bounced by the AO MCU and state updated to the system.

Pod Interface PCB

Note:

Option C does not have a pod port.

The pod interface PCB has gold immersion plated pads for corrosion resistant contacts for electrical connection to an optional Capnography Pod. A cable connects the SDLC and power for the pod to the interconnect PCB. Ball stud contacts in the pod provide more grounding and help secure the pod to the monitor.

Interconnect PCB

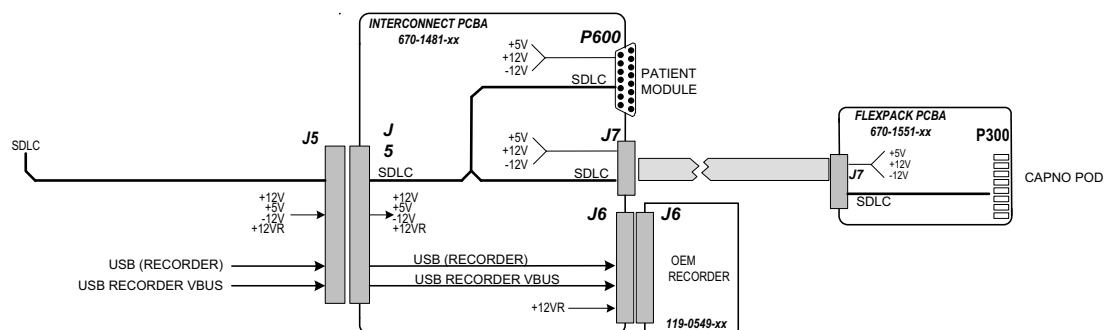

Figure 3-11 Connector PCBA

The interconnect PCB routes SDLC and module or pod power from the CPU to the module bay and pod interface PCB. It also provides a connection point for the optional USB thermal printer. The thermal printer gets power from the 12-V supply and has a separate current limiting circuit split off from the 12-V supply. The recorder talks to the host CPU using USB protocol.





Maintenance

Overview

The following information describes the requirements and tests necessary for safety and performance verification of the monitor.

	Caution:
	Observe precautions for handling electrostatic-sensitive devices!

Notes:

- *Never touch electrostatic-sensitive electronic components without following proper anti-static procedures, including the use of an ESD wrist band and mat. An electrostatic discharge from your fingers can permanently damage electronic components and cause latent failures.*
- *All static-sensitive electronic components are packaged in static-shielding bags. Keep the bag in case you must repackage the component to store it or return it to Spacelabs Healthcare for any reason.*
- *Perform cleaning, preventive maintenance, and safety checks annually and following any product disassembly or assembly. Only trained personnel only should perform preventive maintenance and safety checks.*



Required Test Equipment

- Electrical Safety Analyzer – Dynatech Nevada 232C or equivalent
- Patient Simulator – Dynatech Nevada 300B or equivalent

Notes:

- *Before you test, make sure that the module housing or housings and its DC power supply or supplies have their associated cables attached, but are not interconnected.*
- *Make sure that the Ethernet cable and AC power sources are removed.*
- *The AC line is auto detected; no user selection is necessary.*
- *Ensure that the leakage test equipment is calibrated.*

Mechanical Inspection

Make sure that:

- The monitor and all optional equipment are clean.
- All screws are tight.
- The case and connector pins are not damaged.
- There are no frayed or pinched wires or cables.

Tests for Electrical Safety

To protect the patient from electrical shock, especially micro-shock, do the required safety tests. It has been determined experimentally that current values in the microampere (mA) range can cause fatal arrhythmias in electrically susceptible patients. A patient is deemed electrically susceptible when connected to monitoring equipment.

Definitions

Classification – IEC/EN/UL 60601-1 Safety standard designation for the class of equipment and type of patient applied parts that indicate the degree of protection provided against electrical shock.

Leakage Current – Current that is not functional. It includes patient leakage, ground leakage, and enclosure (or chassis) leakage.

Patient Lead Leakage – Current that flows from the applied part of the patient lead to ground.

Chassis Leakage – Current flowing from the enclosure (or from conductive parts accessible to the operator) through the ground conductor.





Normal Condition — Condition in which all means provided for protection are intact. Includes, ground connections, insulation, creepage, and clearance distances.

Single Fault Condition — Open ground, open neutral, line voltage on a patient connection, or any single state other than normal condition that could compromise patient safety.

UUT — Unit Under Test.

Spacelabs Healthcare does not endorse standards to the exclusion of others. Therefore: **BE SURE TO CHECK YOUR LOCAL REQUIREMENTS TO MAKE SURE YOUR EQUIPMENT SAFETY TESTS COMPLY WITH LOCAL STANDARDS.** Generally accepted standards for medical monitoring equipment, such as the Underwriters Laboratory (UL) and the National Fire Protection Association (NFPA) standards, are summarized in [Table 4-1](#) on page 4-3.

Table 4-1 Summary of Standards for Medical Monitoring Equipment

International Mains to Chassis Leakage	U.S. (120 V) Mains to Chassis Leakage	Mains Resistance
100 μ A - normal condition, ground attached (AC connector to chassis)	300 μ A - normal condition, ground attached (AC connector to chassis)	500 milliohms*
500 μ A - single fault condition, open ground, or reverse polarity	300 μ A - single fault condition, open ground, or reverse polarity	500 milliohms*

* Measured from the AC Power cord third wire ground to the most distant ground attachment

Equipment Required

Electrical Safety Analyzer, Fluke model 232D, or equivalent.

Perform these tests according to the scheduling requirements for the hospital, at least annually or after repair or modification.

	Warning:
	<i>Before you start safety tests, ensure that no patient is connected to the device under test. If safety tests must be performed on equipment currently monitoring a patient, obtain permission to disconnect the cables from the monitor and patient.</i>

Note:

Perform all tests according to the operations manual for the safety analyzer and any local requirements.

Ground Resistance

- 1 Attach the power cord to the monitor under test.
- 2 Measure the resistance from the AC power cord third wire ground to a chassis location, such as the equipotential post on the rear of the monitor.



- 3 Check that the resistance is less than 500 milliohms (0.5 ohms).

Chassis Leakage Current Tests

- 1 Plug the leakage analyzers into mains power.
- 2 Plug the equipment into the AC receptacle on the analyzer.
- 3 Verify that the leakage current from the chassis to ground is less than the values in [Table 4-2](#) on page 4-4.

Table 4-2 Enclosure Leakage Test Conditions and Limits

Neutral Condition	Ground Condition	Polarity	International Limit	U.S. Limit
Closed neutral	Closed ground	Normal polarity	100 μ A	300 μ A
Open neutral	Open ground	Normal polarity	500 μ A	300 μ A
Closed neutral	Open ground	Normal polarity	500 μ A	300 μ A

Patient Lead Leakage Current Tests (Patient Modules)

For patient lead leakage test instructions, refer to the service manual of the specific module or modules you use.

Preventive Maintenance

A Spacelabs Healthcare Field Service Engineer or qualified hospital biomedical technician checks the monitor and optional equipment for acceptable performance and electrical safety. Checks are done to make sure that the monitor and option equipment operate according to current requirements.

Touchscreen Calibration

In the event the touchscreen becomes difficult to use or a replacement has been installed, calibrate it. Calibrate by using the calibration function in the **Biomed** menu.

To perform touchscreen calibration

- 1 Attach a mouse.
- 2 Power ON the monitor and wait for the monitor to pass the self tests.
- 3 Click (or touch) the **Monitor Setup** key.
- 4 Click (or touch) the **Privileged Access** key.
- 5 Enter the Biomed password (default is biomed).
- 6 Click (touch) **Biomed Setup**.
- 7 Click (touch) **Touchscreen Calibration**.





- 8** Wait for the Reset Monitor dialog box to display.
- 9** Click (touch) the **Reset Monitor** key.
The monitor resets. After 15 to 20 seconds, a lighted box will appear in the upper left corner of the screen.
- 10** Touch the lighted box for one or two seconds until it disappears.
Three more lighted boxes appear, one at a time, in the upper right, lower right, and lower left corners.
- 11** Touch the lighted boxes as they appear.
After you touch these four corners one at a time as the boxes appear, the touchscreen is calibrated.

Functional Tests

Monitor Self-Test

A power-ON self-test is performed each time the monitor is turned ON.

- The power ON/OFF switch illuminates indicating +5 V is present.
- If the monitor operates on external AC power, the power LED on the front bezel also illuminates.
- If the monitor operates on AC power and batteries are charging, the battery A and battery B status LEDs on the front bezel flash ON and OFF at a constant rate. Once batteries fully charge, these LEDs remain ON. If no battery is present, one or both of the battery status LEDs remain OFF.

Monitor Functional Tests

This procedure verifies operation of the recorder assembly, network connectivity, alarm relay output, and external SDLC connections. It assumes that a 91496-B or 91496-C multi-parameter module (ECG, RESP, and two PRESS channels) is available for testing purposes. If these parameters are not available, you can substitute similar modules.

Verification of Monitor Functions

Note:

To begin the test, make sure that no modules are inserted and no Flexports or other SDLC devices are connected.

- 1** Plug in the monitor and verify that the front bezel power LED is lit. If one or two batteries are installed, verify that the appropriate battery LED or LEDs are ON solid or flashing.
- 2** To power ON the monitor, press the power ON/OFF switch.
- 3** Verify the following sequence of events:
 - a** The power ON/OFF switch illuminates.



- b** The embedded front and rear alarm light LEDs illuminate briefly. Verify that all LEDs are functional.
 - c** The **Diagnostic** menu displays. (If errors are noted during power ON, contact your Spacelabs Healthcare Field Service Engineer.)
 - d** If batteries are installed, the fan begins operating within 60 seconds after turning ON the monitor. The fan turns OFF unless the internal temperature requires more cooling by the fan.
 - e** Monitor keys display along the right side of the screen.
- 4** Insert the ECG module without a patient cable connected. Verify that the ECG parameter key appears on the screen with **???** and the message *LEADS OFF*.
 - 5** Connect a patient simulator to the ECG input with a patient cable. Set the simulator to a known rate.
 - 6** Verify that the ECG count and the lead being monitored are displayed to the right of the ECG parameter key.
 - 7** Verify that the ECG waveform appears on the screen.
 - 8** Connect a patient simulator to the invasive pressure inputs.
 - 9** Zero the pressures and verify that the numerics and waveforms are accurate.

Optional Recorder Assembly for Options A and B

If the monitor is configured with the optional recorder assembly, verify that the monitor initiates a recording. To verify that the monitor initiates a recording, touch the RECORD key then touch one of the flashing parameter keys.

Note:

The printed waveform should not have defects such as gaps, extra lines, etc. If there are defects, notify a Spacelabs Healthcare Field Service Engineer for servicing, or replace the recorder.

External Alarm Relay Output for Option A

If the monitor is configured to use the alarm relay output, to interface to an external alarm device:

- 1** Plug the cable into the external alarm connector.
- 2** Initiate a high-priority alarm.
- 3** Verify that the external alarm responds appropriately.
- 4** If an external alarm light capable of displaying multiple colors is attached, turn the high-priority alarm OFF. Generate a medium-priority alarm.
- 5** Verify that the external alarm responds appropriately.
- 6** Repeat steps 4 to 5 for a low-priority alarm.





An alternate method is to connect the cable and turn the monitor ON and then OFF. Each color of the embedded alarm light momentarily illuminates. An external alarm light also briefly illuminates.

Ethernet (Wired)

- 1 Attach a 10/100BaseT cable from an active network onto the rear panel connector.
- 2 Verify that the green link light on the connector is ON.

Assembly/Disassembly Procedures

	Caution:
	<p>Before you begin any disassembly procedures, power OFF the monitor, disconnect the AC cord from the AC power receptacle, and remove the batteries.</p>

Note:

The external power supply is not designed for disassembly.

Required Tools and Parts

- Anti-static mat with wrist strap
- #1 and #2 Phillips-head screwdriver
- 3/16-inch nut driver
- Tool, antenna extraction, wireless card, P/N 003-0286-00
- *XPREZZON™ and qube™ System Administration Manual*, P/N 070-2380-xx

Setup for Disassembly

The battery switch has symbols to show when to turn the switch on and off. Turn the switch off for shipping and service (refer to [Figure 4-1](#)). Turn the switch to on for regular operation (refer to [Figure 4-2](#)).

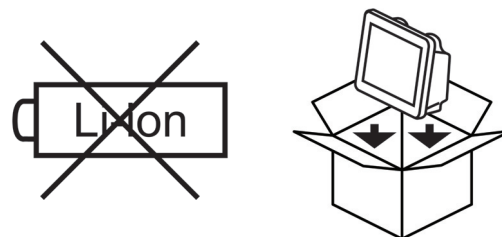

Figure 4-1 Battery Switch Off Symbol

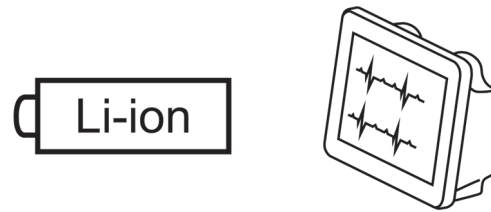

Figure 4-2 Battery Switch On Symbol

For Option A

- 1** Remove the external power supply cable and battery or batteries, if present.
- 2** Remove the patient parameter module.

For Options B and C

- 1** Remove the external power supply cable and turn the battery switch to off.
- 2** Remove the patient parameter module.

Remove the Bezel Assembly

- 1** Place the monitor face-down on a stable and padded surface.
- 2** Remove the eight finishing plugs from the rear enclosure as shown in [Figure 4-3](#) for option A.
- 3** Remove the 10 screws from the rear enclosure, as shown in [Figure 4-3](#).





Figure 4-3 Screw Locations on Option A

- 4 Place the monitor on its feet and separate the bezel assembly from the rear enclosure, as shown in [Figure 4-4](#) on page 4-10.

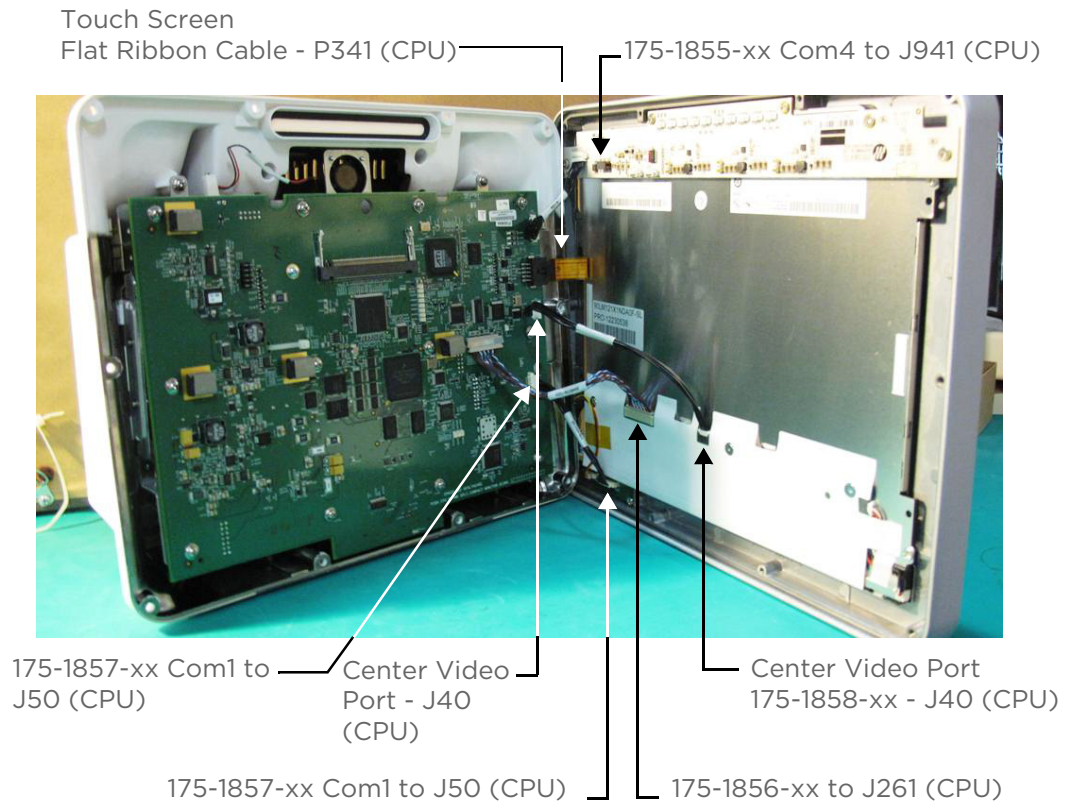

Figure 4-4 Bezel Assembly and Rear Enclosure

- 5 Start from the bottom and disconnect the three black wire bundles from the monitor side. Refer to [Figure 4-4](#).
- 6 Remove the video cable P/N 175-1856-00 from the monitor.
- 7 Disconnect the remaining black ribbon cable from the monitor side. Refer to [Figure 4-4](#).
- 8 Remove bezel assembly.

Reassembly

	Caution:
	Use caution when handling the cables. The cables are fragile and can easily be damaged.

- 1 Position the new bezel assembly as shown in [Figure 4-4](#).
- 2 Connect cable 175-1855-xx Com4 to J941 (CPU).
- 3 Connect cable Center Video Port 175-1858-xx to J40 (CPU).
- 4 Connect cable 175-1856-xx to J261 (CPU).
- 5 Connect cable 175-1857-xx Com1 to J50 (CPU).



Figure 4-5 Connect the cables

- 6 To attach the bezel assembly to the rear enclosure with the 10 original screws. Be careful not to over-tighten the screws.

Note:

The bezel and rear enclosure must align on the bottom of the monitor. The bottom edge of the enclosure must fit into the bezel. Be careful not to pinch any cables, especially the touch screen cable.

- 7 Install the eight finishing plugs removed in [Step 2](#) on page 4-8.
- 8 Perform the functional test procedure. Refer to [Monitor Functional Tests](#) on page 4-5.

CPU PCB

- 1 Perform [Step 1](#) on page 4-8 through [Step 8](#) on page 4-10.

Notes:

- If the wireless option is not installed, skip to [Step 6](#) on page 4-12.
 - The replacement CPU PCB does not come with a new wireless adaptor PCB. Remove the wireless adaptor card and install it on the new CPU PCB.
- 2 To remove the two antenna cables from the wireless card, use the 003-0286-00 antenna extraction tool as shown in [Figure 4-6](#).

	Caution:
	Use caution when handling the two antenna cables. The cables are fragile and can easily be damaged.

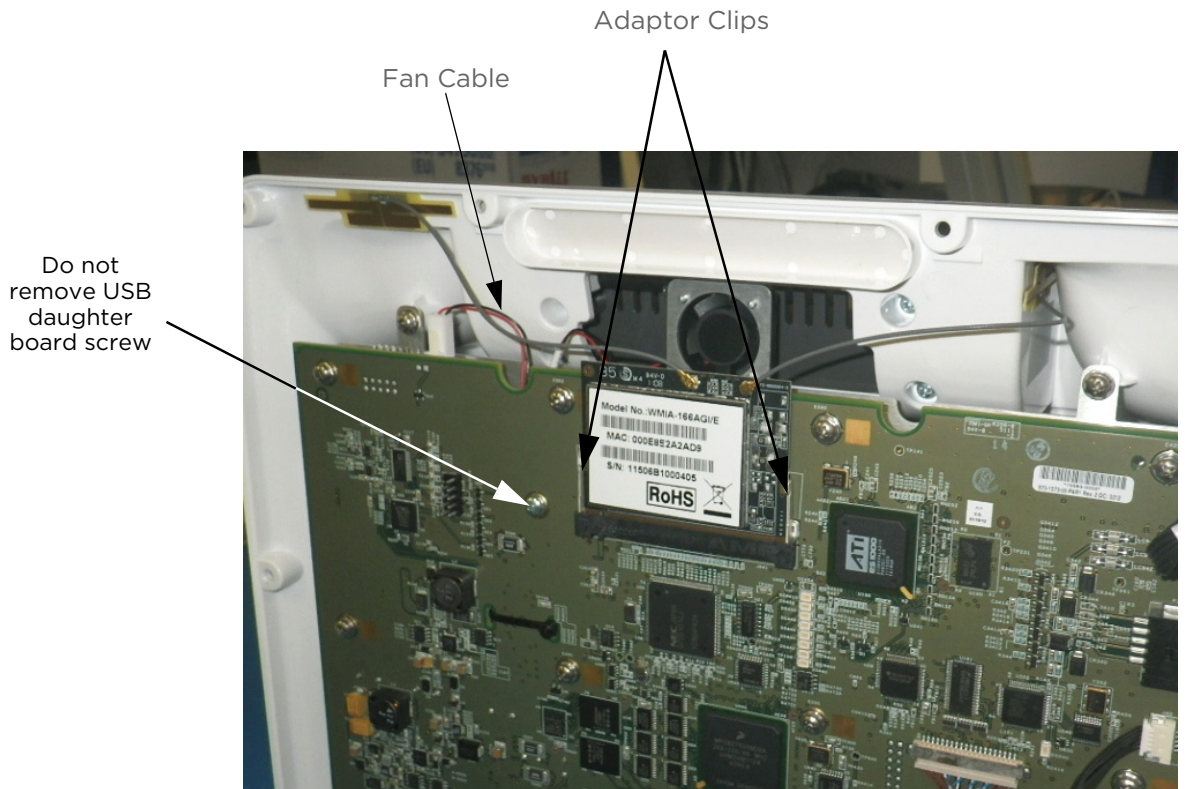

Figure 4-6 Wireless Antenna Cables

- 3** Gently press outward on the retaining clips that hold the wireless adaptor card in place. Remove the wireless adaptor board.
- 4** Set aside the wireless adaptor PCB for installation on the replacement CPU PCB. Use proper ESD protection.
- 5** Disconnect the fan cable from the CPU PCB.
- 6** Remove the 12 screws that secure the CPU PCB to the chassis.

Notes:

- Do not remove the screw that secures the USB daughter board to the CPU PCB. Refer to [Figure 4-6](#).
- The CPU PCB is press fitted onto the connectors, for the interface, monitor dock, and battery PCBs.

- 7** Remove the old CPU PCB. Gently pull the CPU away from the interface, monitor dock, and battery PCB connectors.
- 8** Disconnect the speaker cable from the back-side of the CPU PCB.
- 9** To replace the USB card, remove the screw that attaches the old USB to the CPU PCB. Install the new USB card. Refer to [Figure 4-7](#) on page 4-13.

Notes:

- If you replace the USB daughter card, format and configure it. Refer to the *XPREZZON and qube System Administration Manual* (P/N 070-2380-xx).



- The CPU PCBA contains a USB flash drive PCBA that stores user-created Custom Trends, as well as Citrix certificates required for the DNA feature.
- Reformat the new USB flash drive as part of the CPU replacement procedure.
- When you replace the CPU PCBA, Spacelabs Healthcare recommends that you transfer the old USB flash drive to the new CPU PCBA.

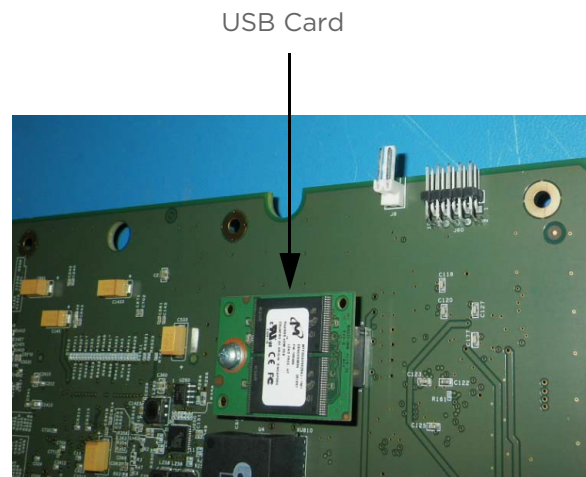

Figure 4-7 USB Flash Drive

- 10** Connect speaker cable to P070 port. Connect the fan cable to J8 Port.
- 11** Install the new CPU onto the chassis. Connect to the battery, monitor dock, and interface PCBs.
- 12** Make sure that the speaker and fan cables are not pinched.
- 13** Use the 12 screws removed in [Step 6](#) on page 4-12 to secure the CPU to the main chassis.
- 14** Reinstall the wireless adaptor PCB. Reconnect the two antenna cables if applicable.
- 15** Place the monitor upright, as shown in [Figure 4-4](#) on page 4-10.
- 16** Position the bezel assembly as shown in [Figure 4-4](#) on page 4-10.
- 17** Connect cable 175-1855-xx Com4 to J941 (CPU).
- 18** Connect cable Center Video Port 175-1858-xx to J40 (CPU).
- 19** Connect cable 175-1856-xx to J261 (CPU).
- 20** Connect cable 175-1857-xx Com1 to J50 (CPU).
- 21** Move the bezel into position. Place the monitor face-down on a stable, padded surface. To attach the bezel assembly to the rear enclosure again, use the original screws and finishing plugs (Refer to [Step 2](#) on page 4-8 and [Step 3](#) on page 4-8).

Note:

Options B and C do not have finishing plugs.



- 22 Make sure that the rear enclosure aligns with the bezel (bottom of monitor).

Restore Data to the Monitor

The CPU PCBA contains a USB flash drive PCBA that stores user-created Custom Trends, as well as Citrix certificates required for the DNA feature. These procedures outline the steps for successful restoration of this data to your monitor when replacing the CPU Flash Drive PCBA.

- 1 Remove and replace the CPU as specified in [CPU PCB](#) on page 4-11.
- 2 Complete replacement of the CPU PCBA transfers a nonformatted and nonprogrammed USB drive PCBA into the qube monitor. Refer to [Figure 4-7](#) on page 4-13 to identify the location of the USB drive.

Select [Option 1: Exchange the USB Drive PCBAs](#) or [Option 2: Format the USB Drive](#) as the next step. Use Option 1 if the USB Flash Drive PCBA currently functions with no errors.

Option 1: Exchange the USB Drive PCBAs

To maintain the user-created customized trends and Citrix certificates in the USB drive, exchange the USB drives between the defective CPU PCBA and the new CPU PCBA.

- 1 Locate the USB Drive is on the back side of the CPU PCBA. Refer to [Figure 4-7](#) on page 4-13 for the location of the USB Drive.
- 2 Remove the screw holding the USB drive to the CPU board.
- 3 Lift the USB drive PCBA away from the defective CPU PCBA.
- 4 Remove the USB drive PCBA from the replacement CPU PCBA.
- 5 Exchange the USB drives between the two CPU PCBAs.
- 6 Reassemble the monitor as described in [Assembly/Disassembly Procedures](#) on page 4-7.

Option 2: Format the USB Drive

The factory does not format the USB flash drive that is on the replacement CPU PCBA. A built-in software utility in the extended diagnostics menu in the monitor formats the USB drive. If the software utility in the monitor does not format the USB drive, the message: *System Software failure. Review error log for further details* shows after the power-ON self tests complete.

Note:

If you receive this message, format the new USB drive and manually reprogram the user-defined Trends and DNA (Citrix) certificates.





- 1 After you install the new CPU PCBA into the chassis, reassemble the monitor as described in [Assembly/Disassembly Procedures](#) on page 4-7.
- 2 Connect the power supply to the 91390 monitor.
- 3 To format the USB drive, power-ON the monitor (cold-boot).
- 4 To enter extended diagnostics, touch the lower corners of the touchscreen in sequence during the 4-3-2-1 countdown. Touch the corners of the visible part of the lighted electronic display (LED), not the corners of the bezel (refer to [Figure 4-8](#) on page 4-15). If you use a mouse, click both the right and left mouse buttons simultaneously during the countdown. The Main Diagnostics Menu is shown in [Figure 4-9](#).

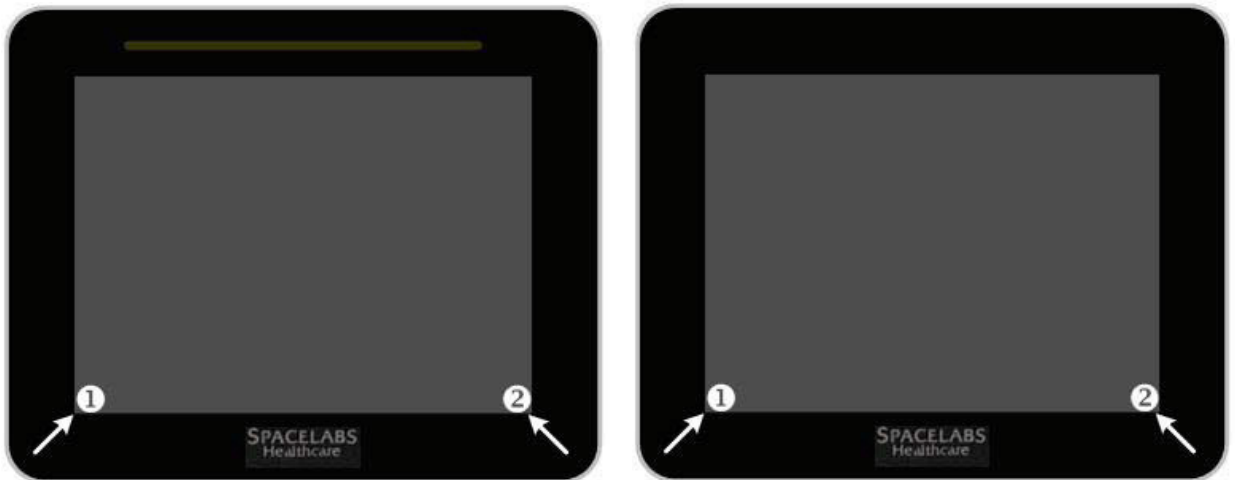

Figure 4-8 Touch Points to Enter Extended Diagnostics on Options A and B (left) and Option C (right)

- 5 Touch or click the **f - format USB file system** key.

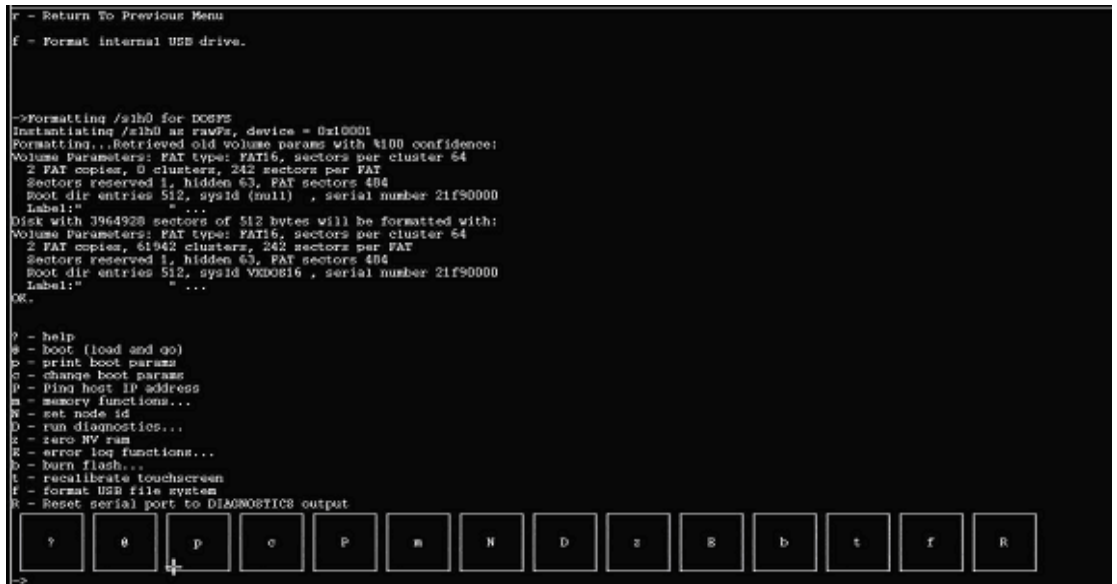

Figure 4-9 Main Diagnostics Menu

The process takes about 10 seconds to complete. The results are shown in Figure 4-10 on page 4-16.



Figure 4-10 Format USB Drive Results Screen

- 6 To cold-boot the monitor, touch or click the **D - run diagnostics**, then the **R - Reset Monitor (cold boot)** keys. Let the monitor to fully boot.
- 7 To restore the faculty user-defined reeds and DNA (Citrix) certificates, refer to the *XPRESSON and qube Bedside Monitoring Operations Manual* (P/N 070-2112-xx).
- 8 Perform the retest procedure. Refer to **Functional Tests** on page 4-5.



Complete Main Chassis Removal

- 1 Remove the bezel by performing [Step 1](#) on page 4-8 through [Step 8](#) on page 4-10.
- 2 To remove the two antenna cables from the wireless card, if present, use the 003-0286-00 Antenna extraction tool as shown in [Figure 4-11](#).
- 3 For option A, remove the four chassis screws, and the two hidden screws seen in [Figure 4-11](#) on page 4-17. For options B and C, remove the two chassis screws and the one hidden screw.

Note:

When you work on chassis components, first remove the CPU PCBA.

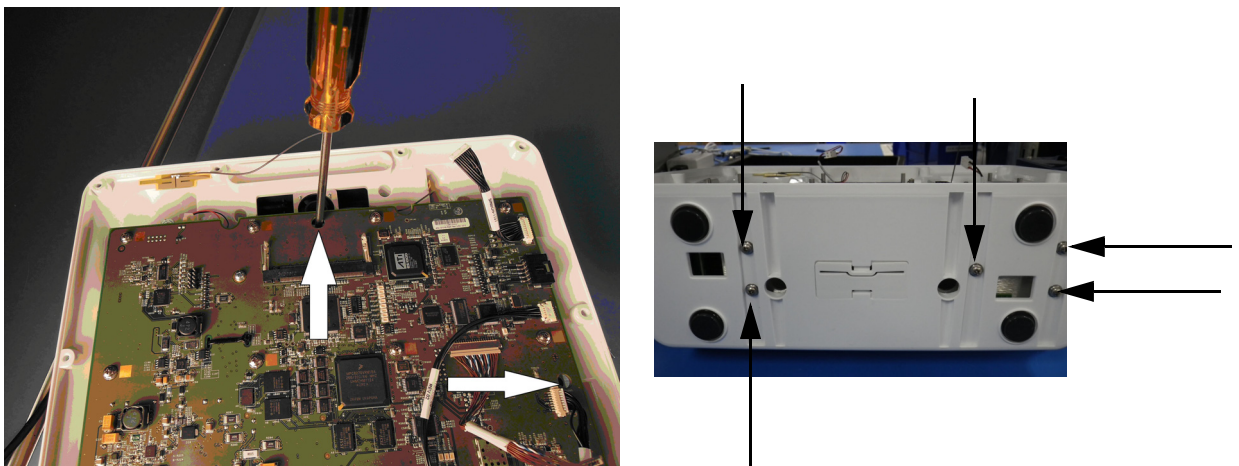
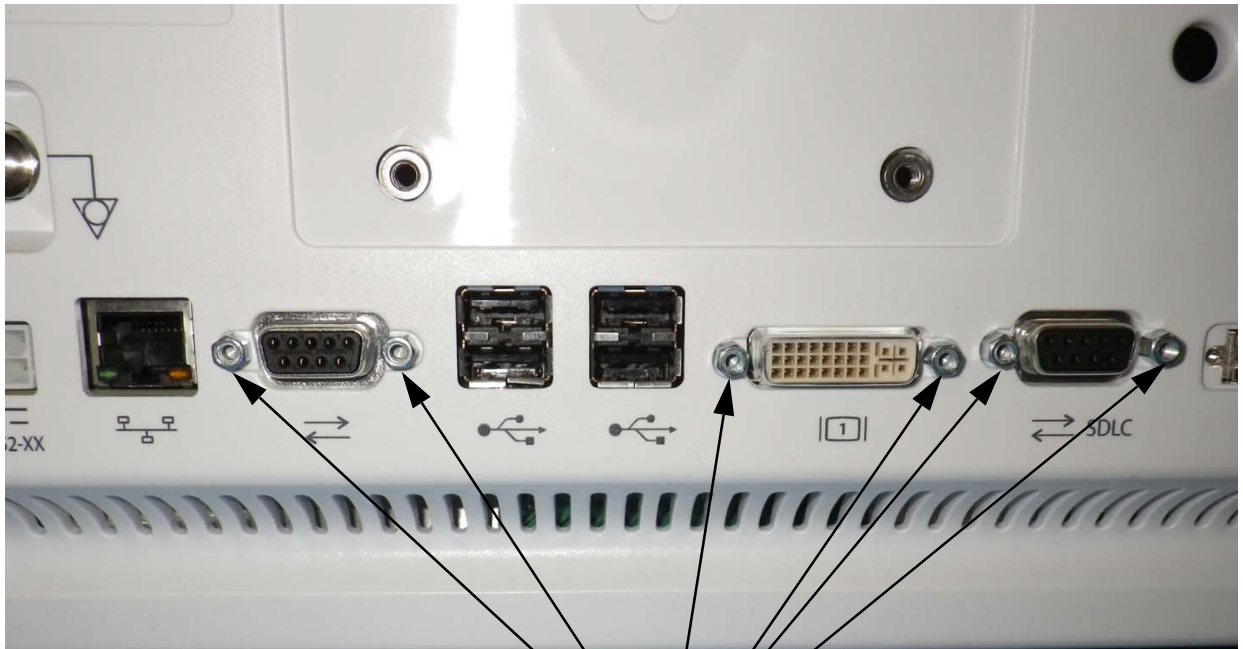

Figure 4-11 Complete Main Chassis Removal

- 4 Place the monitor on its rear panel. Remove the five screws on the bottom of the monitor, as shown in [Figure 4-11](#).
- 5 Place the monitor upright.
- 6 Remove the connector PCB standoffs. Refer to [Figure 4-12](#) on page 4-18.



PCB Standoffs

Figure 4-12 PCB Standoffs

- 7** Open module bay door to access and disconnect the 175-1860-xx Pod interface cable from the Pod Interface Board for options A or B.
- 8** Remove the DSB and docking connector covers as shown in [Figure 4-26](#) on page 4-30 for option C.
- 9** Remove the printer, if present in options A or B.
- 10** With the module bay door open, pull the main chassis from the rear enclosure.

Note:

The DSB connector must clear the rear enclosure. To allow the DSB connector to clear, gently flex the rear enclosure.

Reinstall the Chassis

- 1** With the module bay door open, slide the chassis assembly into the rear enclosure for options A or B.
- 2** Attach the 175-1860-xx Pod interface cable to the Pod Interface Board again.
- 3** Install the four chassis screws again for option A. Install the three chassis screws again for options B or C.



Note:

For option A, install the hidden screw on the lower-right side of the chassis through printer slot and hold the screw in place.

- 4** Install the connector PCB Standoffs again.
- 5** Place the monitor on its rear. Reinstall the five screws on the bottom of the monitor.
- 6** Install the wireless card again, if applicable.
- 7** Attach antenna cables to the wireless card again, if applicable
- 8** Install the bezel again. Refer to Step [Step 15](#) on page 4-13 through [Step 22](#) on page 4-14.
- 9** Perform the retest procedure. Refer to [Functional Tests](#) on page 4-5.

SDLC Interface PCB

- 1** Remove the Bezel Assembly by perform [Step 1](#) on page 4-8 though [Step 7](#) on page 4-10.
- 2** Perform [Step 2](#) on page 4-15 through [Step 7](#) on page 4-18 to remove the Main Chassis assembly.
- 3** Remove the CPU. Refer to [CPU PCB](#) on page 4-11
- 4** Remove the two screws shown in [Figure 4-13](#) on page 4-19.

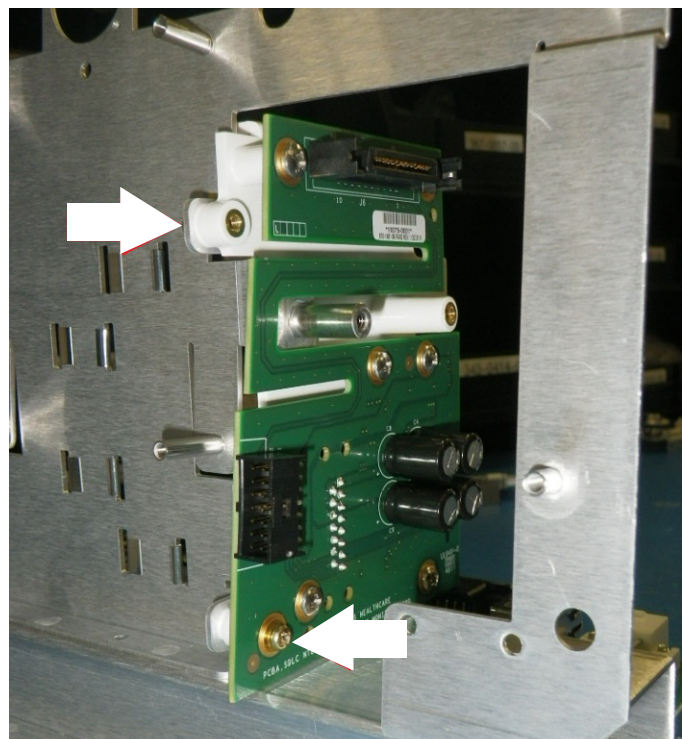

Figure 4-13 SDLC Interface



- 5 Remove the two screws from the SDLC Interconnect as shown in [Figure 4-13](#).
- 6 Install the Interface PCB and mounting bracket in the chassis with the two screws.
- 7 Reinstall the CPU. Refer to [Step 10](#) on page 4-13 through [Step 14](#) on page 4-13
- 8 Slide the complete chassis assembly into the rear enclosure. Refer to [Figure 9](#).
- 9 Reinstall the chassis. Refer to [Reinstall the Chassis](#) on page 4-18.

Speaker

- 1 Perform [Step 1](#) on page 4-18 through [Step 9](#) on page 4-19 to access the Main Chassis assembly.
- 2 Disconnect the speaker connector from the CPU PCB.
- 3 Remove the four mounting tabs that secure the speaker to the speaker bracket as shown in [Figure 4-14](#) on page 4-20.

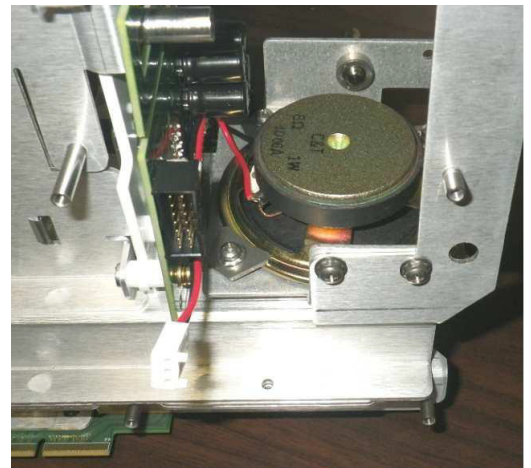
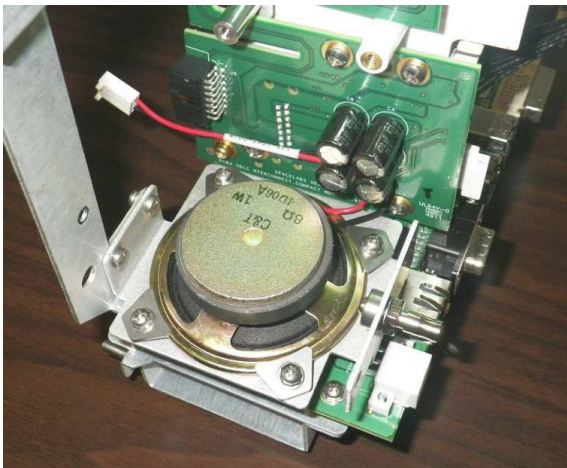

Figure 4-14 Speaker and Speaker Bracket

- 4 Remove the old speaker. Attach the new speaker onto the speaker bracket using the four mounting tabs as shown [Figure 4-14](#).
- 5 Attach the speaker cable to the CPU Board.
- 6 Reinstall the main chassis into the rear enclosure. Attach the bezel to the rear enclosure. Refer to [Reinstall the Chassis](#) on page 4-18.





Mon-Dock PCB

- 1 Perform [Step 1](#) on page 4-18 through [Step 9](#) on page 4-19 to access the Main Chassis assembly.
- 2 With the Chassis assembly face down, remove the seven screws shown in [Figure 4-15](#) on page 4-21 for option A. Remove the five screws for option B or C.

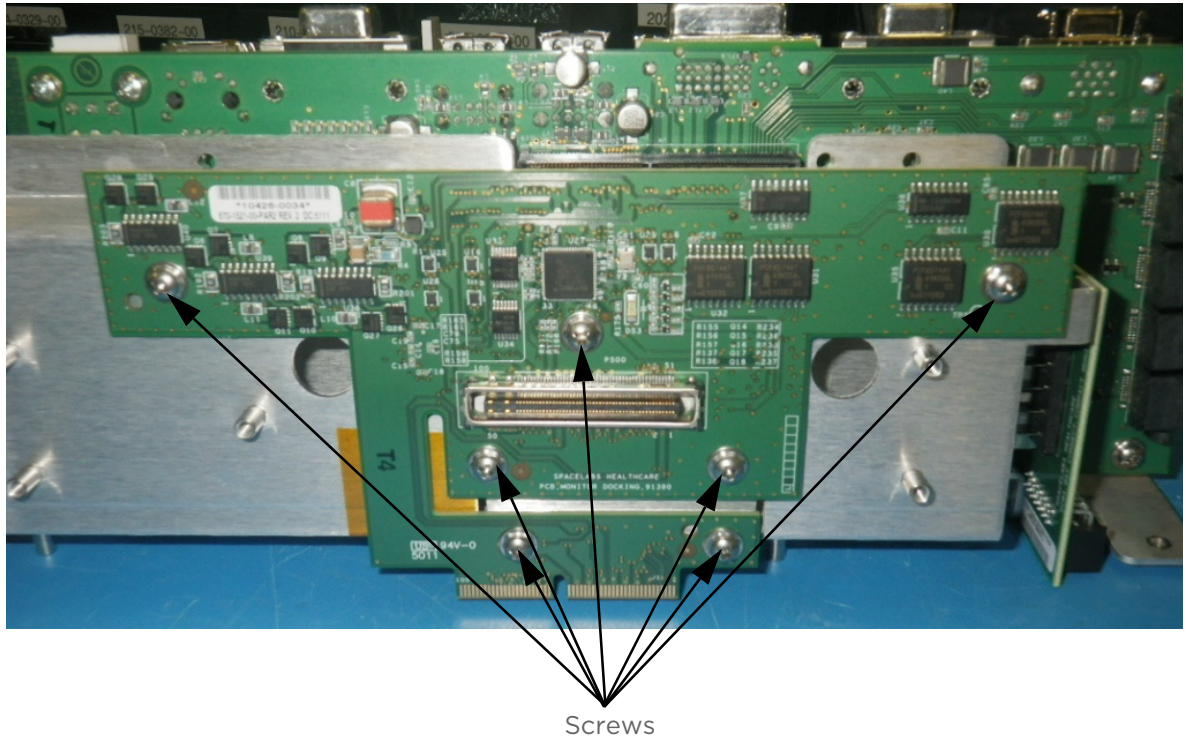

Figure 4-15 Docking PCB

- 3 Replace the old PCB. Attach it again to the bottom of the chassis assembly with the original screws.
- 4 Perform the retest procedure. Refer to [Functional Tests](#) on page 4-5.



Battery Door for Option A

- 1 Open the battery door.

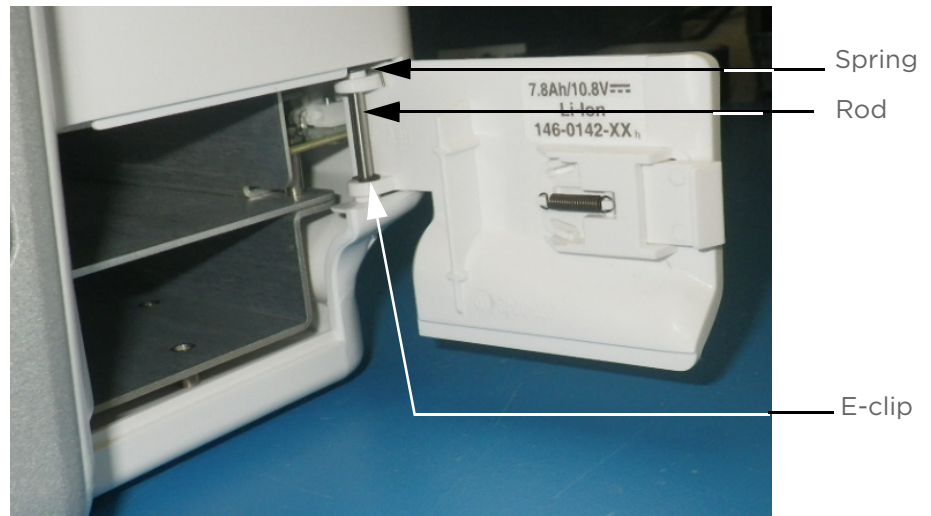

Figure 4-16 Battery Door

- 2 Remove E-clip. Refer to Figure 4-16.
- 3 Slide the rod down through the door and rear enclosure. Refer to Figure 4-16.
- 4 Remove the old door assembly.
- 5 Install the new door assembly.
- 6 Make sure that the spring is positioned correctly. Refer to Figure 4-17.



Figure 4-17 Battery Door Spring

- 7 Slide the rod through the rear enclosure and door.
- 8 Attach E-clip.





Connector Board PCB

- 1 Perform [Step 1](#) on page 4-18 through [Step 9](#) on page 4-19 to access the Main Chassis assembly.
- 2 Remove the three screws, shown in [Figure 4-18](#) for option A. Remove the two screws for options B or C.

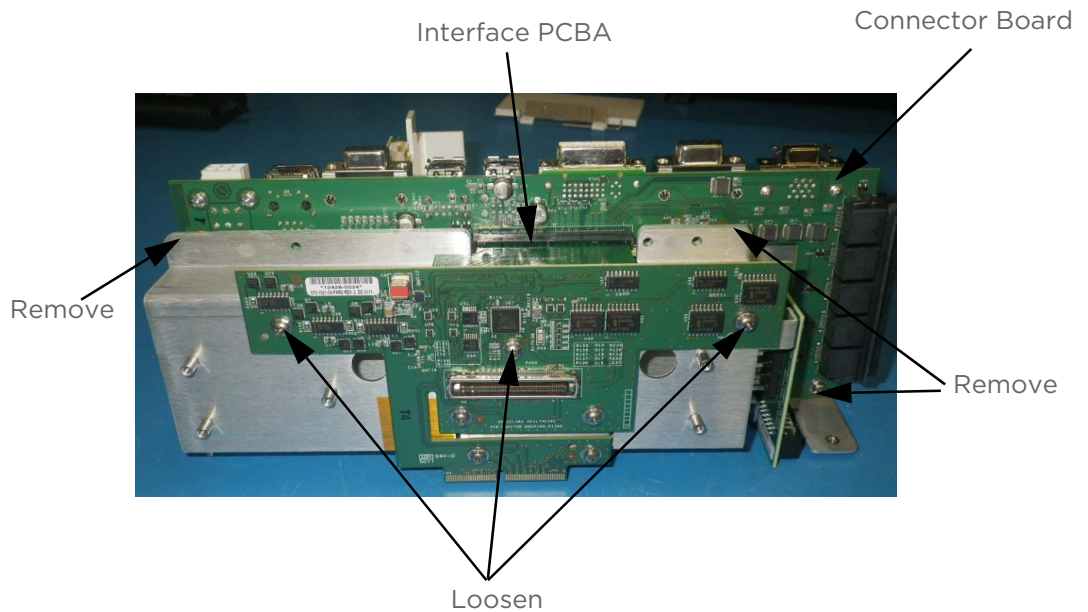

Figure 4-18 Connector Board PCB

Note:

Loosen the top three Monitor Dock PCB screws.

- 3 Remove the Connector Board.
- 4 Install the new Connector Board making sure that the connection to the interface PCB is good.

Note:

Tighten the top three Monitor Dock PCB screws.

- 5 Connect board to the Interface PCBA. Connect to Monitor and Dock boards.
- 6 Install the three screws removed in step 2 for option A. Install the two screws removed in step 2 for options B or C.

Replace the Battery Contact PCB

- 1 Remove the chassis. Refer to [Complete Main Chassis Removal](#) on page 4-17.
- 2 Remove the connector PCB.

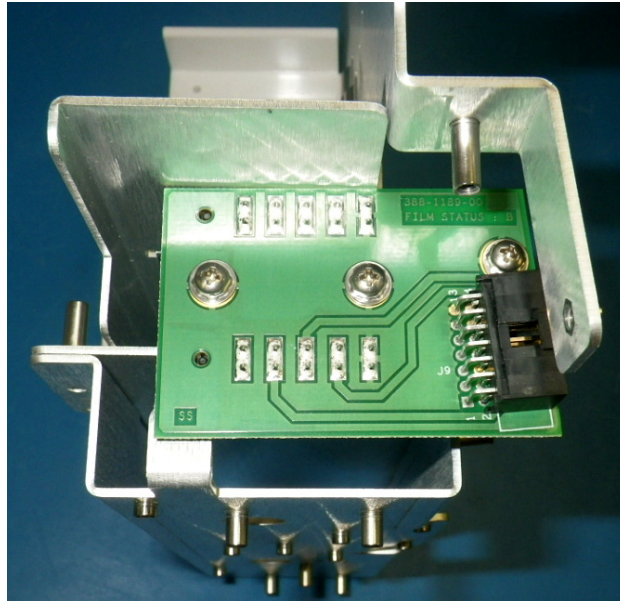

Figure 4-19 Replace the Battery PCBA

- 3 Remove the three screws holding the battery PCB to the chassis.
- 4 Disconnect the battery PCB from the CPU.
- 5 Replace the battery connect PCB.
- 6 Reinstall the connector PCB.
- 7 Reinstall the chassis and bezel assembly.
- 8 Install the battery. Disconnect the AC mains. Make sure the unit powers ON.
- 9 Perform the retest procedure. Refer to [Functional Tests](#) on page 4-5.



Replace and Align the Module Door

- 1 Remove the chassis. Refer to [Complete Main Chassis Removal](#) on page 4-17.
- 2 To remove the door, remove the two screws fastening the hinge to the wall of the module compartment assembly. This frees the door assembly. When you install a new door, do not tighten the two screws until you completely secure the chassis assembly to the rear housing.
- 3 After the chassis and rear housing are reassembled, position the door so that it freely opens and closes, and then tighten the two screws.

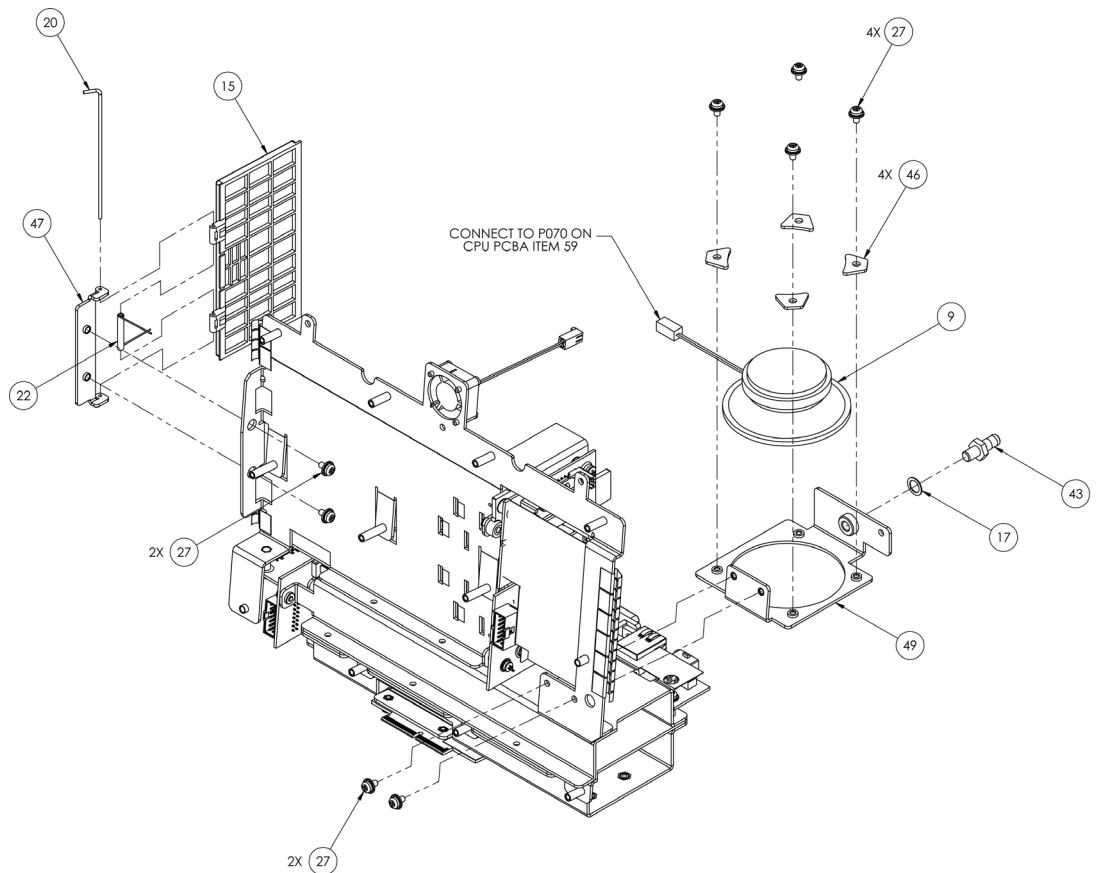

Figure 4-20 Module Door



Handle

- 1 Separate the bezel from the rear enclosure. Refer to [Remove the Bezel Assembly](#) on page 4-8.
- 2 Remove the four screws on the handle cover as shown here [Figure 4-21](#) on page 4-26.

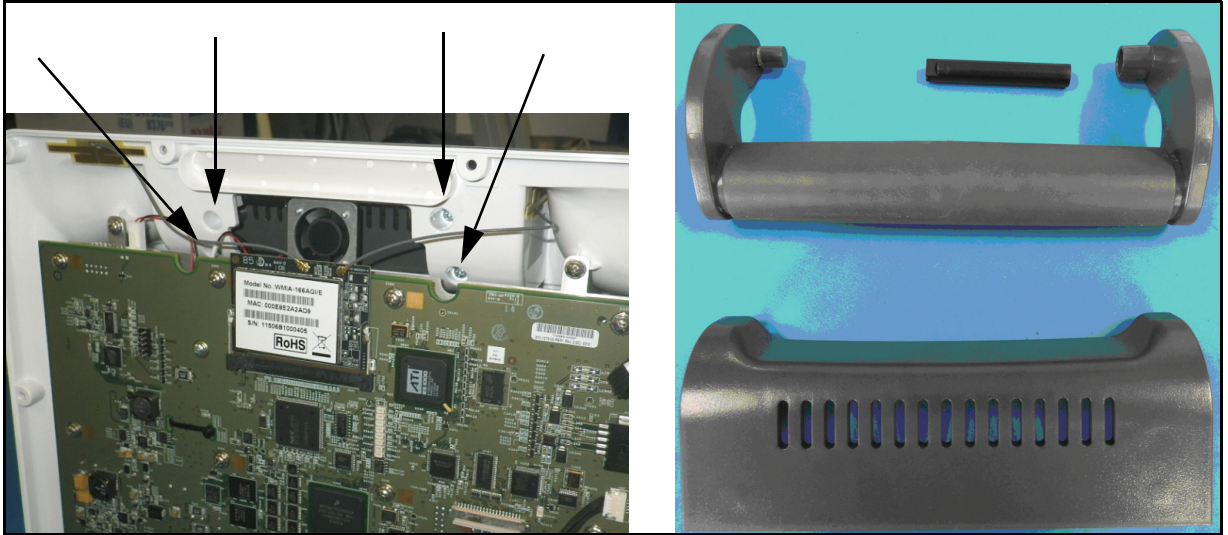

Figure 4-21 Handle

- 3 Remove the handle and dampening rod from the rear enclosure.

Reinstall the Rear Handle Assembly

- 1 Assemble the rear handle so that the dampening rod is inside the tabs on the rear handle cover as shown in [Figure 4-22](#) on page 4-26.

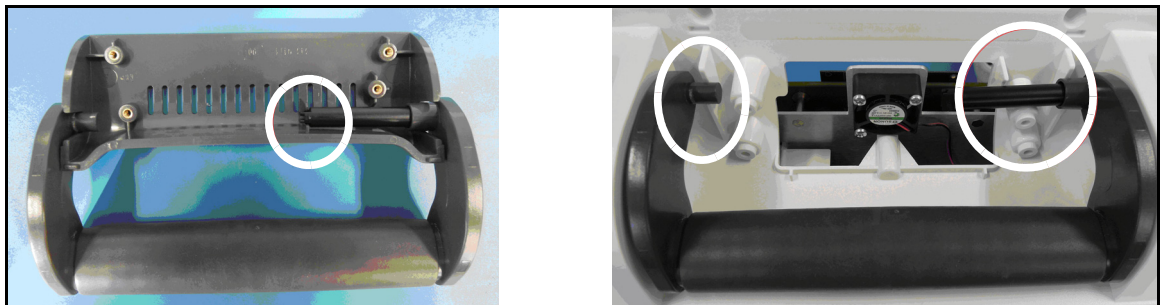

Figure 4-22 Handle Assembly

- 2 To hold the dampening rod in place, slightly tilt the monitor backwards. While it is tilted backwards, install the rear handle assembly. Align the screws and holes. Secure the handle assembly to the rear enclosure with the four screws.





- 3 Attach the bezel assembly again.

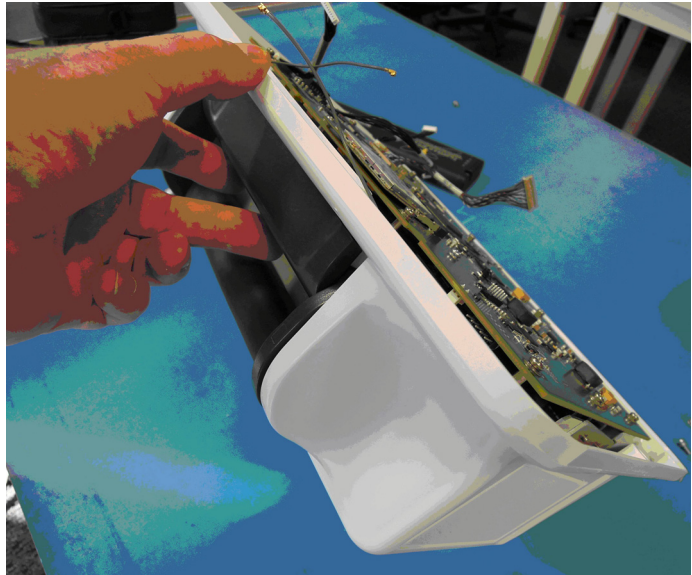

Figure 4-23 Installed Handle

- 4 Perform the retest procedure. Refer to [Functional Tests](#) on page 4-5.

Fan

- 1 Separate the bezel from the rear enclosure. Refer to [Remove the Bezel Assembly](#) on page 4-8.
- 2 Perform [Step 2](#) on page 4-26 and [Step 3](#) on page 4-26.
- 3 Disconnect the fan cable from the CPU board.
- 4 Remove the three screws that secure the fan to the chassis. Refer to [Figure 4-24](#).



Figure 4-24 Fan



- 5 Install the new fan. Secure it to the chassis with the three screws removed in [Step 4](#) on page 4-27.
- 6 Reconnect the fan cable to the CPU board.
- 7 Attach the handle again. Refer to [Reinstall the Rear Handle Assembly](#) on page 4-26.
- 8 Attach the bezel assembly again. Refer to [Remove the Bezel Assembly](#) on page 4-8.

Install or Replace the Optional Recorder Assembly

Note:

Unless purchased separately for a monitor already in the field, the recorder option is installed at the factory. Order an upgrade from your local sales representative.

For options A and B only.

	Warning:
	<i>A safety hazard is created if the mylar insulator is not properly installed over the recorder CPU PCBA.</i>

To install the recorder

- 1 Power OFF the monitor and remove the batteries.
- 2 Remove the printer “dummy panel.”
- 3 Insert the recorder assembly. Make sure that it fully engages the connector at the back of the recorder compartment. To open the recorder assembly, press the release bar. tighten the two Phillips-head screws at the rear of the recorder.





Figure 4-25 Recorder Assembly and CPU PCBA

To replace the recorder

- 1 If the recorder assembly is installed, open the printer door. Loosen the two captive screws. Pull out the assembly at the top. Refer to [Figure 4-25](#).
- 2 To reinstall, use the instructions in [Step 3](#) on page 4-28.

Insert Recorder Paper

Two rolls of thermal recorder paper are included with the optional recorder assembly.

To insert a roll of paper

- 1 Press the release bar at the right of the recorder assembly. The front of the recorder assembly is hinged at the bottom. Two spoon-shaped arms that hold the paper roll spindle between them drop down.
- 2 Unroll a short length of paper from the roll. Orient the roll so that the paper feeds from the bottom.
- 3 Slip the paper roll spindle between the plastic arms. Close the front of the assembly so that the end of the paper roll sticks out of the recorder assembly.

Dock Connector Covers for Option A

The covers are snap-on and snap-off, and can be removed by hand.

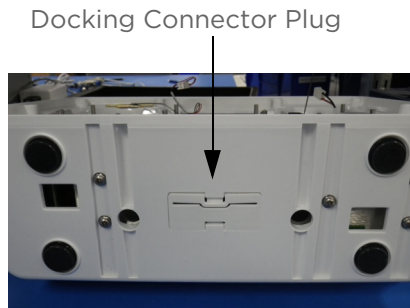

Figure 4-26 Docking Connector Plug

Removal of Pod Interface PCBA for Options A and B

Refer to Drawing 7 for details and find the replacement assembly kit listed with the [Parts List](#) on page 6-2.

- 1** Power OFF the monitor and remove the battery or batteries.
- 2** Remove the module from the monitor.
- 3** Disconnect the POD interface cable (Item 14).
- 4** Use a right-angle Phillips head screw driver to remove the six screws (items 27) while you hold the POD interface bracket (item 48) to the rear enclosure.
- 5** Remove the POD interface bracket. Do not remove the "Ball Stud" clips.
- 6** Remove the four terminal washers (items 18).
- 7** You can gently pull on the PCBA if necessary, as there is a gasket sealing the PCB to the rear enclosure.
- 8** Inspect the POD interface PCBA gasket and "Ball Studs" for any visible damage. Replace them if necessary.

Reinstallation of the Pod Interface PCBA

- 1** Before you install the new POD interface PCBA again, make sure that the POD interface gaskets and ball studs are not damaged. Replace them as necessary.
- 2** If not already completed, attach the POD interface gaskets (Items 38 and 39) to the rear enclosure.
- 3** Place the monitor on a flat surface, so that the display side faces up. Place the POD Interface PCBA and terminal washers in their respective locations.
- 4** Place the two "Ball Stud" clips (Item 36) in place, and use the six screws (Items 27) to attach the POD Interface bracket (Item 48).
- 5** Reconnect the POD interface cable (Item 14).
- 6** Perform the retest procedure. Refer to [Monitor Functional Tests](#) on page 4-5.



Docking Station PCBA Replacement Procedures for Option A

Required Tools and Parts

- Antistatic mat with wrist strap
- #1 and #2 Phillips-head screwdriver
- 3/16-inch nut driver
- Docking Station PCBA (P/N 670-1558-xx)

	<p>Caution:</p> <p>Before you begin any disassembly procedures, disconnect the AC cord from the AC power receptacle. Make sure to use the proper procedures to handle electrostatic-sensitive devices.</p>
---	---

Docking Station



Figure 4-27 Qube Docking Station

- 1 Disconnect all cables from the docking station.
- 2 Turn the docking station over. Remove the six screws from the docking station cover plate. Refer to [Figure 4-28](#) on page 4-32.

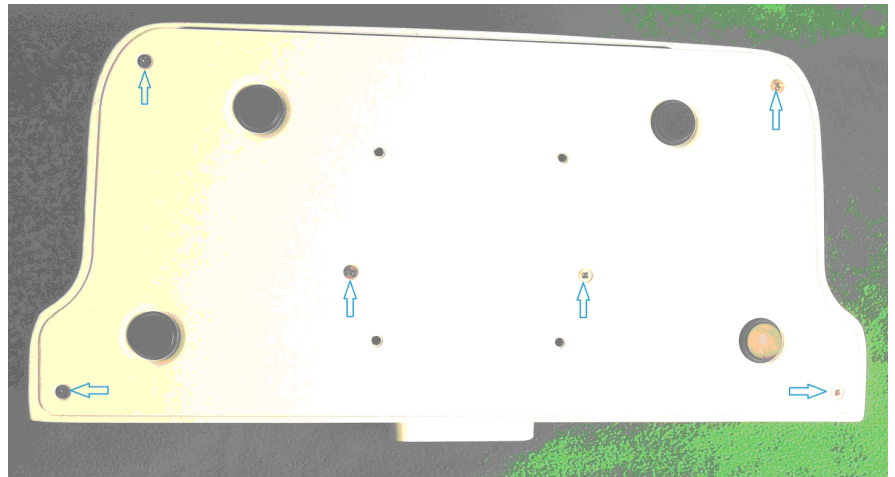

Figure 4-28 Docking Station Bottom View

- 3 Remove the docking station cover plate. Set it aside.
- 4 Remove the connection J70 (docking station release button LED power) from the docking station PCBA. Refer to [Figure 4-29](#).
- 5 Remove the seven (7) screws from the monitor docking PCBA. Refer to [Figure 4-29](#).

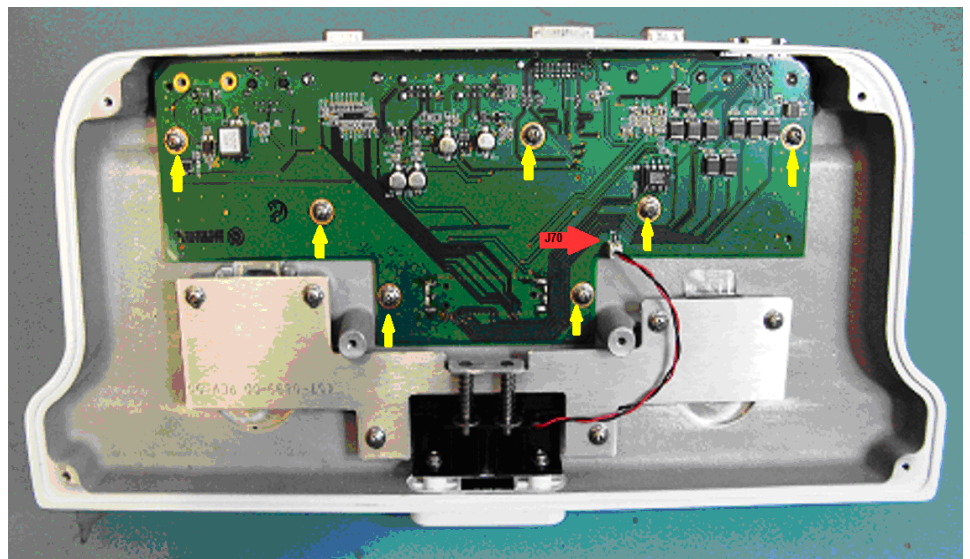

Figure 4-29 Docking Station Enclosure

- 6 To make room to slide out the docking station PCBA, loosen the six screws on the latch assembly in order. Refer to [Figure 4-30](#) on page 4-33.

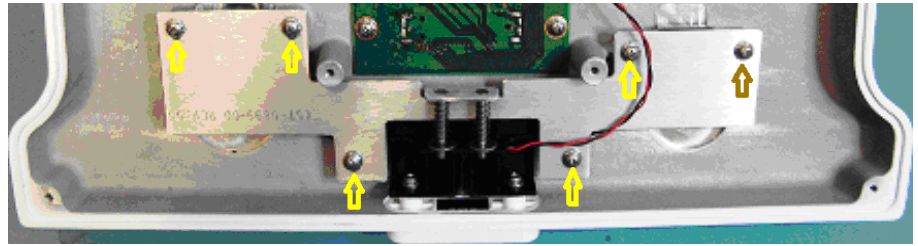

Figure 4-30 Latch Docking Station

- 7 Remove the six (6) connector standoff screws from the back of the docking station with a nut driver. Refer to [Figure 4-31](#).

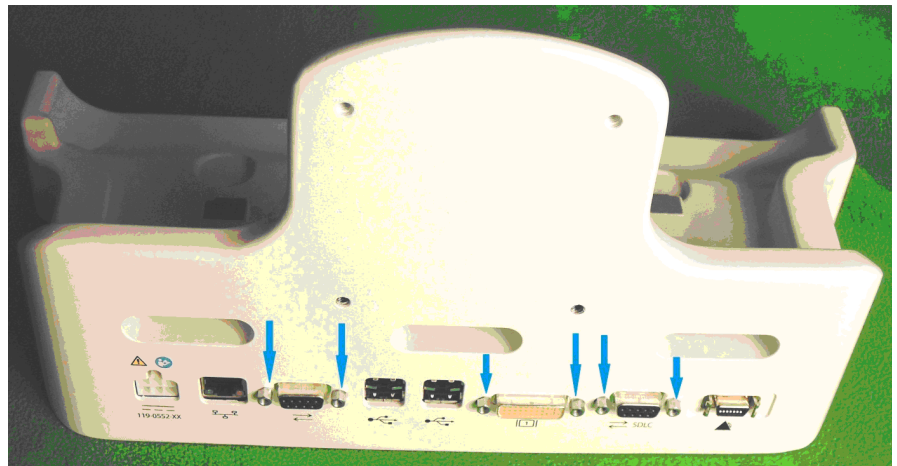

Figure 4-31 Docking Station Connectors

- 8 Turn the docking station back over. Carefully slide out the docking station PCBA. Do not damage the connectors.
- 9 Install a new docking station PCBA in the reverse order.
- 10 Perform functional tests in accordance with the monitor functional tests. Refer to [Figure 4-30](#).

Replace the Docking Station Latch

- 1 Disconnect all cables from the docking station.
- 2 Turn the docking station over. Remove the six screws from the docking station cover plate. Refer to [Figure 4-27](#) on page 4-31.
- 3 Remove the docking station cover plate. Set it aside.
- 4 Remove the connection J70 (LED wiring assembly) from the docking station PCBA. Refer to [Figure 4-32](#).

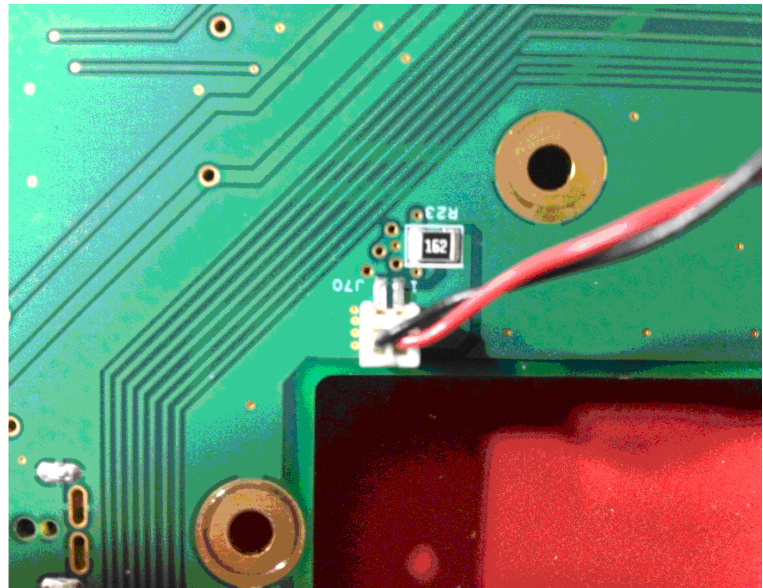

Figure 4-32 LED Wiring Assembly Connection J70

- 5** Remove the six (6) screws on the latch assembly. Refer to [Figure 4-30](#) on page 4-33.
- 6** Carefully remove the pins, springs, and washers. Refer to [Figure 4-30](#) on page 4-33.
- 7** Remove the two (2) screws from the push-button support bracket.
- 8** Remove the push button.
- 9** Install the new latch assembly in reverse order.
- 10** Make sure that the docking station accepts the monitor correctly.

Replace the Docking Station Push Button

- 1** Do the steps to replace the docking station latch.
- 2** Remove the screws holding the push-button assembly. Refer to [Figure 4-30](#) on page 4-33.
- 3** Replace with a new push button.
- 4** Reassemble the unit in reverse order.
- 5** Make sure that the push button operates correctly by docking and undocking a monitor.



Cleaning

To clean the case, wash it with mild soap and water or use Plast-N-Glas cleaner. To clean the electronic connectors and contacts, use TF solvent as necessary.

	Caution:
	<ul style="list-style-type: none">• Do not autoclave.• Never use solvents, acetone, abrasive cleaning agents, or abrasive cleaning pads.• Only use approved cleaning agents, including 70% alcohol, soap and water, green soap, or 10% bleach solution.• Do not directly spray liquids into the recorder, module, or battery compartments.

Refer to the *XPREZZON and qube Bedside Monitoring Operations Manual* (P/N 070-2112-xx) for more information.





Troubleshooting

Overview

The first several sections describe the available diagnostics features and how to use them. Next is a section which lists diagnostics failure messages and the suggested corrective actions. The last section gives specific troubleshooting steps which can be used to isolate failures.

The troubleshooting procedures in this chapter isolate equipment problems to a Field Replaceable Unit (FRU).

The following items are field replaceable:

- PCBA, CPU, P/N 670-1573-xx (all options)
- PCBA, Interconnect, P/N 670-1481-xx (options A and B)
PCBA, Interconnect, P/N 670-1644-xx (option C)
- PCBA, Monitor Dock, P/N 670-1521-xx (option A)
PCBA, Monitor Dock, P/N 670-1647-xx (options B and C)
- PCBA, Connector, P/N 670-1522-xx (option A)
PCBA, Connector, P/N 670-1645-xx (options B and C)
- PCBA, Battery Connector, P/N 670-1555-xx (option A)
PCBA, Battery Connector, P/N 670-1658-xx (options B and C)
- External DC Power Supply, P/N 119-0552-xx (all options)
- Pod interface, P/N 670-1550-xx (options A and B)
Pod interface, P/N 670-1559-xx (option C)

	Caution:
	Observe precautions for handling electrostatic-sensitive devices!



Notes:

- Never touch electrostatic-sensitive electronic components without following proper anti-static procedures, including the use of an ESD wrist band and mat. An electrostatic discharge from your fingers can permanently damage electronic components and cause latent failures.
- All static-sensitive electronic components are packaged in static-shielding bags. Keep the bag for repackaging the component to store it or return it to Spacelabs Healthcare for any reason.

Required Tools and Parts

The items that follow are necessary for troubleshooting and repair:

- Anti-static mat with wrist strap
- #1 and #2 Phillips-head screwdriver
- Standard flat screwdriver
- Multimeter

System Startup

The **System Boot** window is shown when the monitor is first powered ON.

Error Window. This window displays any diagnostic failures and other system errors during the boot process.

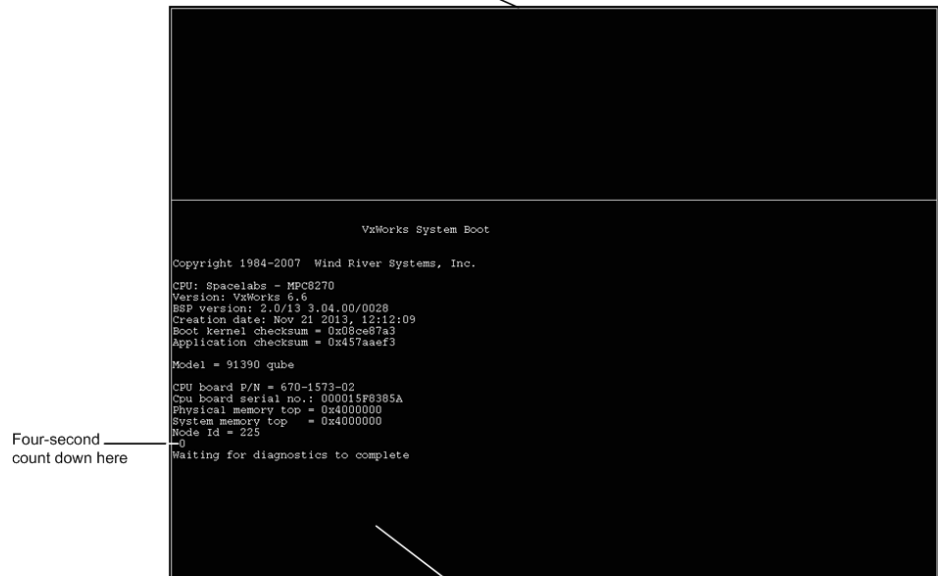

This window displays basic system configuration and booting status during the boot process. The **Boot** and **Diagnostics** menus also appear here.

Figure 5-1 System Startup Window





System

When this screen is shown, the monitor automatically begins Power-On diagnostics. Any diagnostic failures are reported in the upper window. If no serious diagnostics failures are encountered, the monitor continues past this screen and starts normal monitor operation.

You can halt the booting operation during the 4-3-2-1 countdown and a **Boot** menu can be shown.

The **Boot** menu and the power-ON diagnostics are described in the sections that follow.

Power-ON Diagnostics

Power-ON diagnostic tests make sure of system hardware integrity during power-on and can often help isolate and troubleshoot a problem. Most of these tests can also be done in the extended diagnostic mode.

The diagnostics done at power-ON include:

- CPU—reads and writes control registers and does an internal wraparound of one serial communication controller channel.
- DRAM read/write—reads and writes DRAM above 1 MB.
- Real-time clock—makes sure that the clock is running.
- GDS SRAM—reads and writes all of the SRAM, nondestructively.
- Video—tests the video memory, video controller, H-sync, and blue video signals.
- Ethernet—reads and writes control registers.
- Flash checksum—checksums all flash memory.
- Touchscreen—tests the touchscreen controller.
- Audio—reads and writes control registers in the codec.

Power-ON diagnostic failures are reported in the upper portion of the **System Startup** screen. For more information, refer to [Boot Menu](#) on page 5-4.

Any error that occurs during one of these tests is logged in the nonvolatile configuration memory. To retrieve the log, refer to [Error Log](#) on page 5-11.

You can halt the booting operation during the 4-3-2-1 countdown to enter the **Boot** menu. A description of the **Boot** menu is given in the next section.

Boot Menu

The **Boot** menu can only be accessed during a system startup (cold boot). It allows access to several basic configuration menus and functions of the monitor, including Extended Diagnostics. If the serial port is configured for DIAGNOSTICS in the Biomed Menu, all text shown on the screen is also output to the serial port.

To access the Boot menu if the display is functional

- 1** Power ON the monitor and wait for the 4, 3, 2, 1 countdown (Refer to [Figure 5-1](#) on page 5-2).
- 2** Before the countdown expires, do the following step based on what equipment you use that is connected to the serial port:
 - **Touchscreen** — Touch the bottom left and then the bottom right corner (not simultaneously) of the screen ([Figure 5-2](#) on page 5-4).
 - **Mouse** — Click the left and right mouse buttons simultaneously.
 - **Terminal or Keyboard** — Press CTRL+D.

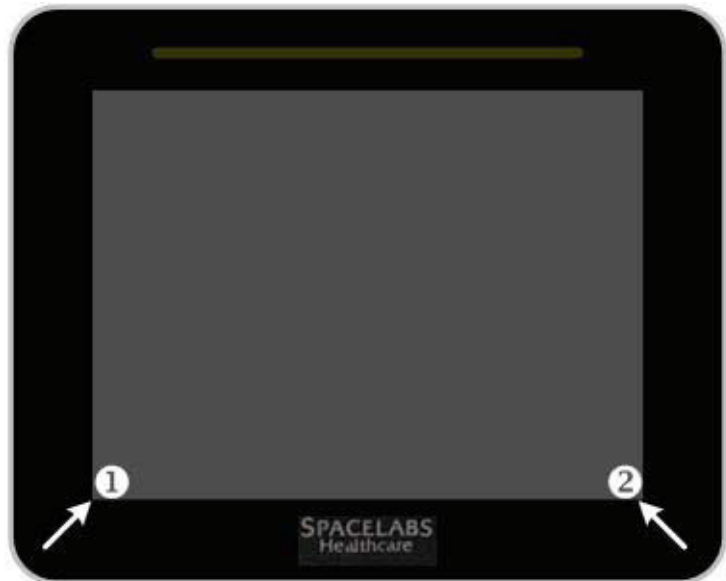

Figure 5-2 Touch Points to Enter Extended Diagnostics



The Boot menu appears as shown in [Figure 5-3](#).

```

Boot kernel checksum = 0x00ce87a3
Application checksum = 0x457aef3
Model = 91390 qube
CPU board P/N = 670-1573-02
Cpu board serial no.: 000015B385A
Physical memory top = 0x4000000
System memory top   = 0x4000000
Node Id = 225
4
Waiting for diagnostics to complete

? - help
@ - boot (load and go)
p - print boot params
c - change boot params
P - Ping host IP address
m - memory functions...
N - set node id
D - run diagnostics...
z - zero NV ram
E - error log functions...
b - burn flash...
t - recalibrate touchscreen
f - format USB file system
R - Reset serial port to DIAGNOSTICS output

```

? @ p c P m N D z E b t f R

Figure 5-3 Boot Menu

	<p>Caution:</p> <p>Use caution when you do the functions in this menu. The user should only execute Diagnostics (D) or use the Error Log (E). The rest of the features are only for qualified Spacelabs Healthcare field service engineers.</p>
---	--

Note:

All menu selections are case-sensitive when using a keyboard or terminal.

The following keys are available in the Boot menu:

- ? – Provides an explanation of this menu.
- @ – Starts the monitoring application.
- p – Prints the boot parameters
- c – Allows boot parameters to be changed.
- P – Allows this monitor to ping the host IP address [host inet (h)].
- m – Requires a data key (Spacelabs Healthcare Field Service Engineers only). The **Memory** menu shows ([Memory Menu](#)). This menu has limited value in the field.
- N – Allows the node ID to be changed and sets the monitor ID number in Network Setup.
- D – The **Main Diagnostic** menu shows ([Main Diagnostic Menu](#)).



z — With a data key present (Spacelabs Healthcare Field Service Engineers only): Zeros and initializes the NVRAM with factory defaults. All Options and network settings revert to factory defaults.

Without a data key present: Zeros and initializes the NVRAM, but maintains the Options settings, TCP/IP settings and Node (Monitor) ID.

E — Displays the **Error Log Functions** menu, which allows the error log to be cleared or dumped to the screen and serial port.

b — Displays the **Burn Flash** menu, which allows new boot kernel or application software to be loaded over the network and burned into flash memory (Spacelabs Healthcare Field Service Engineers only).

t — Recalibrates the touchscreen (monitor automatically resets).

f — Formats the USB device on the CPU board assembly.

R — Resets the serial port to DIAGNOSTICS output. This allows the use of the serial terminal to access and control DIAGNOSTICS.

Boot Parameters

To display the boot parameters, touch the **p** (lower-case) key in the **Boot** menu. [Figure 5-4](#) and [Figure 5-5](#) shows the out-of-the-box factory default settings. By default, the **gateway inet** parameter is not shown. Touch **Continue** to return to the **Boot** menu.

If any of the boot parameters are incorrect, touch **c** from the **Boot** menu. Each parameter setting is presented, one at a time. If the setting is correct, touch the <ENTER> key to go on. If the setting is incorrect, use the key to delete the incorrect text, and then retype the entry using the onscreen keyboard. Touch **@ - boot (load and go)** to reboot the monitor with the new settings.

```
->
boot device      : motfcc
unit number     : 0
processor number : 0
host name       : stymie
file name       : c:\salish\app\app
inet on ethernet (e) : 164.90.254.10:ffffff00
host inet (h)    : 164.90.254.66
user (u)        : target
ftp password (pw) : passwd1
flags (f)       : 0x0
Press key to continue...
->
```

Figure 5-4 Boot Parameters Menu with Factory Default Settings (v3.01.00)





```
->
boot device      : motfcc
unit number     : 0
processor number : 0
host name       : stymie
file name       : c:\qube\app\app
inet on ethernet (e) : 164.90.254.10:ffffff00
host inet (h)    : 164.90.254.66
user (u)        : target
ftp password (pw) : passwd1
flags (f)       : 0x0

Press key to continue...

->
```

Figure 5-5 Boot Parameters Menu with Factory Default Settings (v3.03.00 and higher)

Extended Diagnostics

Extended diagnostic tests, like the power-ON diagnostics, can be used to troubleshoot and isolate many system failures. The types of tests and features available in the extended diagnostics are:

- Power-ON diagnostics.
- Interactive tests and read/write memory tests that are not appropriate during power-ON diagnostics.
- Touchscreen calibration and data dump utilities.
- System data dump and system reset utilities.

The diagnostic menus allow most of these tests to be run individually or all at once. If **Loop** mode is activated, a test can be executed in a continuous loop. If **Halt On Error** mode is activated, the looping stops when a diagnostic failure is detected. To avoid false failures, do not use the touchscreen, mouse, or keyboard while the diagnostic tests execute.

Any error that occurs during one of these tests is logged in the non-volatile memory (NVRAM). Refer to [Error Log](#) on page 5-11 to retrieve the log.

For detailed information on extended diagnostics and how to run them, Refer to [Diagnostic Menu](#) on page 5-8.

Diagnostic Menus

Main Diagnostic Menu

To show the **Main Diagnostic** menu (Main Diagnostic Menu), touch the **D** key in the **Boot** menu.



Figure 5-6 Main Diagnostic Menu

The following functions are available in the Main Diagnostic menu:

r – Returns to the **Boot** menu.

a – Runs the same tests that run during power-ON diagnostics.

i – The Individual Diagnostic menu shows ([Individual Diagnostic Menu](#)).

l – Toggles **Loop** mode ON or OFF. When **Loop** mode is ON, selected test or tests are run continuously, until power is toggled OFF.

h – Toggles **Halt On Error** mode ON or OFF. The system stops on the test that failed, and displays the results on the screen.

s – Shows system information, including power supply and battery status details, address spaces and variables used in the system.

R – Causes a cold boot reset just like toggling the power OFF.



Individual Diagnostic Menu

To display the **Individual Diagnostic** menu, touch the **i** key in the **Main Diagnostic** menu. Tests designated by the asterisk (*) are the same tests that are executed during power ON. Except where noted, these tests are pass/fail only.



Figure 5-7 Individual Diagnostic Menu

The following keys are available in the Individual Diagnostic menu:

- r** — Returns to the **Main Diagnostic** menu.
- c** — Tests certain CPU functions, similar, but not identical to, the power-ON CPU test.
- a** — Runs the power-ON audio diagnostic. An audible tone is heard at the completion of the test.
- w** — Runs the power-ON wireless LAN diagnostic (if installed).
- e** — Runs the power-ON Ethernet test.
- R** — Makes sure that the real-time clock is running.
- m** — Displays the **Memory** menu ([Memory Menu](#)).
- v** — The **Video** menu shows ([Video Menu](#)).
- t** — The **Touchscreen** menu shows. Interactive test.
- X** — Runs the DSB diagnostics.
- f** — Shows the **Fan Control** menu (v3.03.00 only). Interactive test. Fan control is returned to normal operations upon exiting the **Fan** menu.
- s** — Safety Circuit test (requires -O2 or higher CPU PCBA, and v3.03.00 or higher installed). Interactive test.



Memory Menu

To show the **Memory** menu, touch the **m** key in the **Individual Diagnostic** menu. Tests designated by the asterisk (*) are the same tests that are executed during power ON. These tests are pass/fail only.



Figure 5-8 Memory Menu

The keys that follow are available in the **Memory** menu:

r – Returns to the **Individual Diagnostics** menu.

d – Runs a Dynamic RAM (DRAM) test, similar to the power-ON DRAM test, but tests only the memory not in use by the boot kernel.

f – Performs the power-ON Flash checksum.

F – Performs a read/write test on the application area of flash memory, which overwrites the application software. Reload the software after the test. Requires a data key (Spacelabs Healthcare Field Service Engineers only).

g – Runs the power-ON GDS SRAM test. The SRAM stores the trend data (GDS) for the patient.

n – Performs a checksum on NVRAM.

N – Requires a data key (Spacelabs Healthcare Field Service Engineers only). Performs a read/write test of the NVRAM, which overwrites configuration parameters in NVRAM. After the NVRAM test completes, NVRAM must be zeroed with the data key attached. The boot parameters and sysgen values must be reentered.





Video Menu

To show the **Video** menu, touch the **v** key in the **Individual Diagnostic** menu.

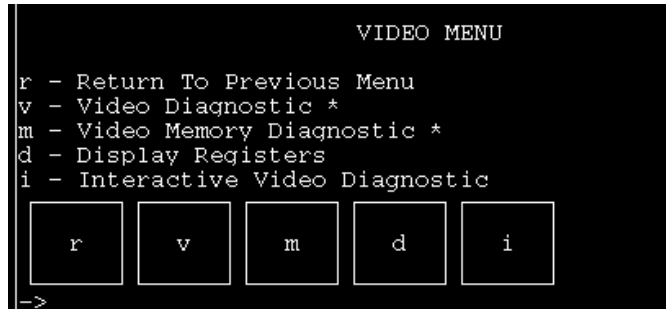

Figure 5-9 Video Menu

The following keys are available in the **Video** menu:

- r** — Returns to the **Individual Diagnostics** menu.
- v** — Runs the power-ON video diagnostic.
- m** — Runs the video memory diagnostic. This test is a more extensive test than the power-ON video memory test. This test could take up to five minutes to complete.
- d** — Shows the display registers.
For product test only- it is of little use in the field.
- i** — Runs an interactive video diagnostic, which displays red, green, blue, white, and black screens, for five seconds each. Inspect the screen for faulty pixels.

Error Log

To troubleshoot intermittent problems, the monitor maintains an error log for both recoverable and non-recoverable errors in its battery-backed, non-volatile memory (NVRAM). All diagnostics failures are logged in the error log.

Most errors relate to the CPU PCBA, but parameter modules or software errors can cause errors. For example, a particular sequence of key strokes that always produces the same error code could be a software problem.

Refer to the *XPREZZON and qube System Administration Manual* (P/N 070-2380-xx) for monitor configuration of the **System Info** and **Error Log** tabs under **Privileged Access**.



View the Error Log

Make sure that all other procedures have been followed before you use the error log, including:

- elimination of operator errors
- voltage tests
- correction of display faults
- diagnostic testing
- cable or connector repairs
- software compatibility

From the **Boot** menu (Refer to [Boot Menu](#) on page 5-4), touch **E** to access the **Error Log Functions** menu. Touch **d** to view the **Error Log**. The most recent errors are listed first.

```
r - Return To Previous Menu
d - dump error log
c - clear error log

--- Logged Events ---
0: DIAG: 12/23/13 10:24:50: 0x01030611: tDiag0
Unknown error: Wrong voltaage for batt B
0x3423860 0x34270f4 0x34736b8
-----
1: DIAG: 12/23/13 10:24:50: 0x0103060f: tDiag0
Unknown error: Wrong chemistry for batt B
0x342383c 0x34270f4 0x34736b8
-----
2: DIAG: 12/23/13 10:20:46: 0x01030000: bootApp
System Power-on diagnostics passed
0x3479660 0x34754fc 0x34736b8
-----
3: DIAG: 12/23/13 09:42:40: 0x01030611: tDiag0
Unknown error: Wrong voltaage for batt B
0x3423860 0x34270f4 0x34736b8
-----
4: DIAG: 12/23/13 09:41:26: 0x01030000: bootApp
System Power-on diagnostics passed
0x3479660 0x34754fc 0x34736b8
-----
5: DIAG: 12/23/13 08:56:48: 0x01030000: bootApp
System Power-on diagnostics passed
0x3479660 0x34754fc 0x34736b8
-----
Press key to continue...
->
```

Figure 5-10 **Error Log** Shown in Extended Diagnostics

You can also view the **Error Log** from the **Biomed** menu (refer to [Figure 5-11](#) on page 5-13 for more information).





Figure 5-11 Error Log in the **Biomed** Menu

- 1 Select **Next** or **Back** to scroll through the entire contents of stored Error Log information. The Error Log is stored in the NVRAM. The number of errors that can be stored depends on the error type, and NVRAM capacity.
- 2 Select **Recent** to view the newest error information added to the Error Log.
- 3 Select **Print** to print the Error Log data that appears in the current display.
- 4 Select **Clear** to clear the Event Log memory. The **Clear** button is not available unless the user logged in at the Service level.



Diagnostics Failure Messages and Error Codes

If the monitor fails power-ON diagnostics or extended diagnostics, do the items that follow:

- 1** To verify the failure, power the monitor OFF and ON again or run the extended diagnostics, as described in [Diagnostic Menus](#) on page 5-8.
- 2** Once you verify the failure, take troubleshooting action or replace the field-replaceable units (FRU) based on the diagnostics failure messages that follow.

Table 5-1 Diagnostic Failure Messages

Error Code	Diagnostics Failure Message	Suggested Action
01030000	<i>Diagnostics passed</i>	No action required.
01030001	<i>Diagnostic(s) failed; degraded performance</i>	Replace CPU PCBA.
01030002	<i>Critical failure</i>	Replace CPU PCBA.
01030003	<i>Cannot diagnose at this boot stage</i>	No information available.
01030100	<i>Diagnostics Port Test failed</i>	Replace CPU PCBA.
01030200	<i>8260 Test failed</i>	Replace CPU PCBA.
01030201	<i>8260 SCC Transmit failed</i>	Replace CPU PCBA.
01030202	<i>8260 SCC configuration not recognized</i>	Replace CPU PCBA.
01030300	<i>DRAM Test failed</i>	Replace CPU PCBA.
01030301	<i>DRAM Test can't allocate memory</i>	Reboot and retest. If problem persists, replace CPU PCBA.
01030400	<i>GDS RAM Test failed</i>	Replace CPU PCBA.
01030500	<i>FLASH ROM Test failed</i>	Replace CPU PCBA.
01030501	<i>FLASH ROM boot larger than Flash</i>	Reburn boot kernel software into Flash memory and retest. If failure persists, replace CPU PCBA.
01030502	<i>FLASH ROM app larger than Flash</i>	Reburn application software into Flash memory and retest. If failure persists, replace CPU PCBA.
01030503	<i>FLASH ROM boot checksum error</i>	Reburn boot kernel software into Flash memory and retest. If failure persists, replace CPU PCBA.
01030504	<i>FLASH ROM app checksum error</i>	Reburn application software into Flash memory and retest. If failure persists, replace CPU PCBA.
01030505	<i>FLASH ROM read/write memory test error</i>	Replace CPU PCBA.





Table 5-1 Diagnostic Failure Messages (Continued)

Error Code	Diagnostics Failure Message	Suggested Action
01030600	<i>Power Subsystem Test failed</i>	Replace CPU PCBA.
01030601	<i>A2D Converter failed to convert</i>	Replace CPU PCBA.
01030602	<i>Invalid power request</i>	Replace CPU PCBA.
01030603	<i>Temperature out of spec</i>	Replace CPU PCBA.
01030700	<i>PCI Bridge Test failed</i>	Replace CPU PCBA.
01030701	<i>PCI Bridge configuration not recognized</i>	Replace CPU PCBA.
01030702	<i>PCI Bridge registers are not writable</i>	Replace CPU PCBA.
01030703	<i>PCI Bridge revision not valid for clinical use</i>	Replace CPU PCBA.
01030800	<i>Ethernet Test failed</i>	Replace CPU PCBA.
01030801	<i>Ethernet Setup failed</i>	Replace CPU PCBA.
01030802	<i>Ethernet Transmit failed</i>	Replace CPU PCBA.
01030A00	<i>Video Test failed</i>	Replace CPU PCBA.
01030A01	<i>Invalid display type</i>	Replace CPU PCBA.
01030A02	<i>Invalid display size</i>	Replace CPU PCBA.
01030A03	<i>Video configuration not recognized</i>	Replace CPU PCBA.
01030A04	<i>Video DRAM failure</i>	Replace CPU PCBA.
01030A05	<i>Video could not detect H-sync signal</i>	Replace CPU PCBA.
01030A06	<i>Video could not detect blue video signal</i>	Replace CPU PCBA.
01030C00	<i>OS error while diagnosing KBD</i>	Reboot and retest. If problem persists, replace CPU PCBA.
01030C01	<i>Cannot access KBD device registers</i>	Replace CPU PCBA.
01030C02	<i>KBD did not respond to command</i>	Replace keyboard. Replace CPU PCBA.
01030C03	<i>KBD failed self test</i>	Replace keyboard. Replace CPU PCBA.
01030C04	<i>KBD failed interface test</i>	Replace keyboard. Replace CPU PCBA.
01030D00	<i>Cannot access AUDIO device registers</i>	Replace CPU PCBA.
01030D01	<i>Could not open audio device</i>	Reboot and retest. If problem persists, replace CPU PCBA.
01030D02	<i>Audio device did not respond correctly</i>	Replace CPU PCBA.
01030D03	<i>Audio Loopback test failed</i>	Replace CPU PCBA.



Table 5-1 Diagnostic Failure Messages (Continued)

Error Code	Diagnostics Failure Message	Suggested Action
01030E00	<i>NVRAM Test failed</i>	Replace CPU PCBA.
01030E01	<i>NVRAM Clock not running</i>	Replace CPU PCBA.
01030E02	<i>NVRAM checksum error</i>	Zero the NVRAM and reboot. Re-program all items in the Biomed and Clinical menus (Spacelabs Healthcare Field Service Engineers only). If problem persists, replace CPU PCBA.
01030E03	<i>NVRAM read/write memory test failed</i>	Replace CPU PCBA.

System Troubleshooting

This section describes troubleshooting procedures. You can use these procedures with or separately from the diagnostics to isolate a failure.

Suggested Tools/Test Equipment

- Anti-static mat with wrist strap
- #1 and #2 Phillips-head screwdriver
- 3/16-inch nutdriver standard flat screwdriver
- Multimeter





Qube Monitor Does Not Power ON

When you connect an external power supply to AC-mains and to the monitor, the AC-mains indicator illuminates to show that the DC-input is good. If you install batteries, the battery status indicators are lit as well. Refer to [Figure 5-12](#).

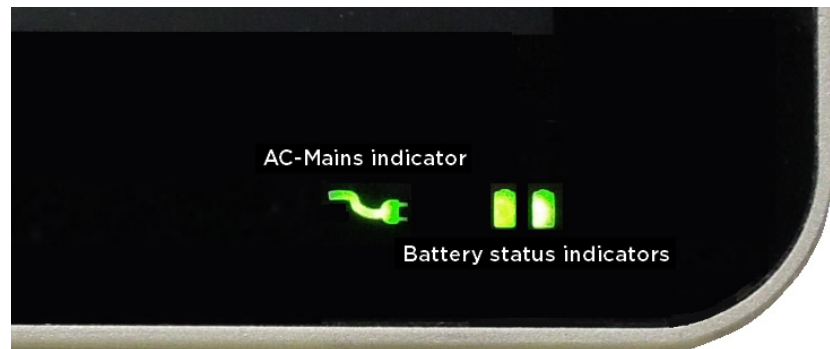

Figure 5-12 AC-Mains and Battery Status Indicators

If the AC-mains indicator is not lit, check that the external power is good. The green LED on the power supply lights. Replace if necessary.

- 1 If the power supply is good but the AC-mains indicator is not lit, the power supply section of the CPU PCBA is not functioning. Check and replace these parts in order:

- 1 Connector PCBA
- 2 Mon-Dock PCBA
- 3 CPU PCBA

If the AC-mains indicator is lit, depress ON/OFF switch on the unit. The ON/OFF switch illuminates and the system begins the startup sequence. If the switch illuminates but the system does not start up, refer to the troubleshooting flowchart: [Qube Monitor Powers ON, But Fails System Startup](#) on page 5-19.

- 1 If the ON/OFF switch does not illuminate when pressed, disassemble the monitor. Check the cable connections between the Front-end assembly and the CPU PCBA. Check and replace these parts in order:
 - 1 Front-end (bezel) assembly. Check ON/OFF switch and the cable to indicator board
 - 2 Cable between indicator board and CPU PCBA
 - 3 Connector PCBA
 - 4 Mon-Dock PCBA
 - 5 CPU PCBA



91390 qube Monitor Does Not Power ON

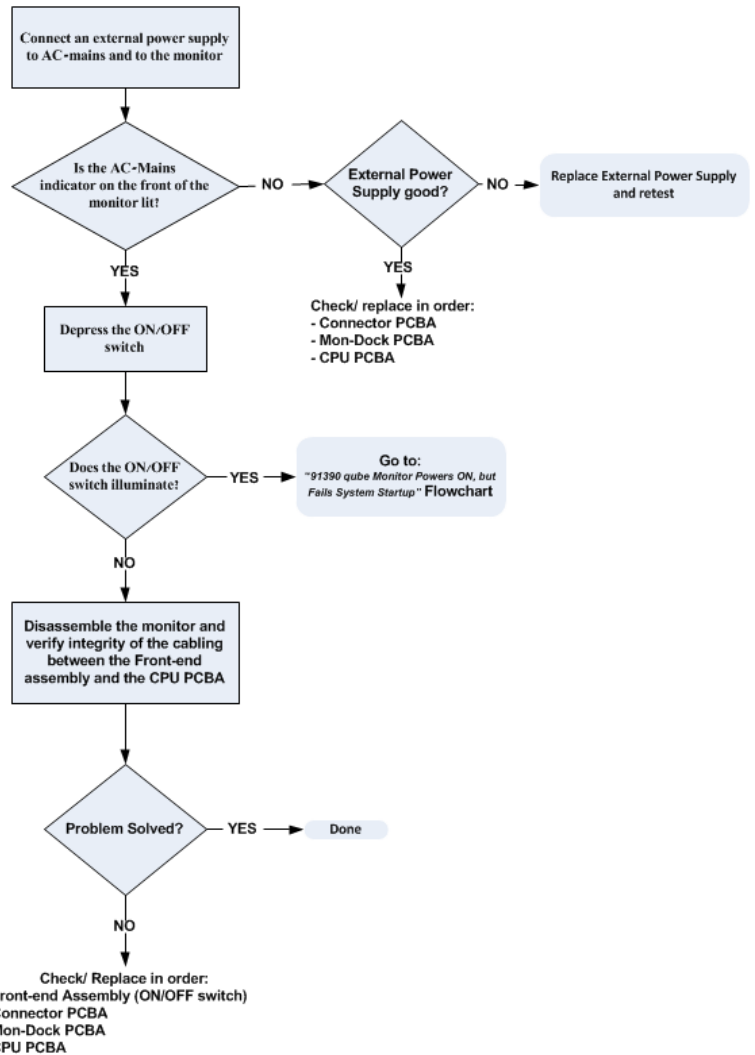

Figure 5-13 qube Monitor Does Not Power ON Flowchart





Qube Monitor Powers ON, But Fails System Startup

If the ON/OFF switch illuminates when depressed but does not boot up, access the Extended Diagnostics through touchscreen or the mouse to identify the extent of the failure. Refer to [Figure 5-3](#) on page 5-5. If there is no display, use the Terminal Emulation method.

91390 qube Monitor Powers ON, But Fails System Startup

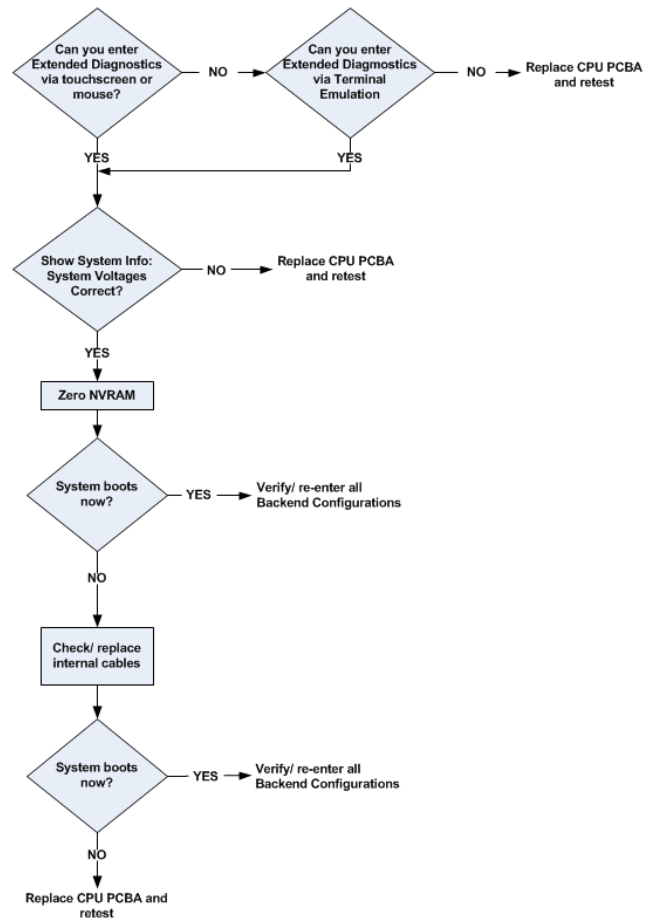

Figure 5-14 qube Monitor Powers ON But Fails System Startup Flowchart



If you cannot access the **Boot Menu** from Terminal Emulation, the boot sector of the Flash ROM in the CPU could be corrupted. Replace the CPU PCBA. If you can access the **Boot Menu** through Terminal Emulation, the boot sector of the Flash ROM in the CPU is functional. To determine the cause of the fault, do the following steps:

- 1 To see if any power-on tests fail, watch the startup sequence. Troubleshoot accordingly.
- 2 Choose **s- Show system info** from the **Main Diagnostic Menu**. Check that all system voltages are present. Refer to [Figure 5-6](#) on page 5-8.

```

F - Return to boot menu
a - Run all bootup diagnostics
i - Run an individual diagnostic...
l - Toggle "Loop Mode" ON/OFF
h - Toggle "Halt On Error Mode" ON/OFF
s - Show system info
R - Reset monitor (cold boot)

->

-----
Firmware version: V2.0
Battery A installed
Battery B installed
Battery B has charging inhibited
Battery A capacity at 37 percent
Battery B capacity at 100 percent
Vin is 19.66 volts
Vcom is 19.44 volts
V18V is 18.00 volts
V12V is 12.02 volts
V5V is 5.03 volts
V3 3V is 3.32 volts
V3 3A0 is 3.32 volts
VM12V is -12.09 volts
BattATemp is 33.4 degrees(C)
BattBTemp is 28.4 degrees(C)
PCBTemp is 43.7 degrees(C)
-----
Press key to continue...
->

```

Figure 5-15 Extended Diagnostics: System Voltages

If these voltages are out of tolerance, replace the CPU PCBA:

Description	Notes
Firmware version: v2.0	
Battery A installed	Status messages
Battery B installed	Status messages
Battery B has charging inhibited	Status messages Ex
Battery A capacity at 47%	Status messages
Battery B capacity at 100%	Status messages
Vin	Checked on AC only. 18.0 to 22.0 V
Vcom	18.0 to 22.0 V on AC; shutdown @ <16 V or >24 V 9.0 to 12.6 V on battery
V18V	Checked on AC only 18.0 to 22.0 V
V12V	+/- 5% (11.4 to 12.6 V); Shutdown @ +/- 20% (<9.6V or >14.4 V)
V5V	+/- 6% (4.7 to 5.3 V) Firmware shutdown @ +/- 10% (<4.5 V or >5.5 V)





Description	Notes
V3_3V	+/- 6% (3.1 to 3.5 V) Firmware shutdown @ +/- 10% (<3.0 or >3.3)
V3_3AO	+/- 6% (3.1 to 3.5 V)
VM12V	+/-5% (-13.2 to -10.8 V)
BattATemp	Status messages
BattBTemp	Status messages
PCBTemp	Warning at 60 °C, shutdown at 75 °C

- 3 Choose **p-print boot parameters** from the **Boot Menu**. Compare the result with [Figure 5-6](#) on page 5-8.
 - a If the boot parameters are incorrect, select **z-zero NV ram** from the **Boot Menu** to reset the boot parameters to their factory defaults. For changes to take effect, perform a cold boot. If the system boots properly, verify all Backend (Biomed/Clinical Menu) configurations.
 - b If zeroing the NVRAM does not restore the defaults, replace the NVRAM or the CPU PCBA.
 - c If the boot parameters are correct, choose **a- Run all bootup diagnostics...** from the **Main Diagnostic Menu** to identify the source of the failure.
- 4 If the previous steps do not correct the problem, replace the CPU PCBA.

High-pitched Tones Heard from the qube Monitor and No Display is Present

Applicable to units with serial numbers 1390-1xxxxx and higher. The System Failure Alarm emits a two-frequency high-pitch tone when one of these four conditions occurred:

- Serial communications between the main CPU and the Always-On CPU is interrupted.
- The main CPU detected a fault and triggers the safety circuit itself.
- The Always-On CPU (power supply section) detected a fault and triggers the safety circuit itself.
- AC-Mains loss, without battery installed, or battery depleted.

Power off the qube monitor to reset the safety circuit. Access the error log (Refer to [Figure 5-10](#) on page 5-12) to identify the cause of the alarm.

- 1 If the error log indicates that the CPU or Always ON CPU caused the alarm to trigger, replace the CPU PCBA.
- 2 If the error log indicates that the battery was depleted, (“Vcom Failed on Battery”) recharge or replace the battery

System Software Failure Window Shown Immediately After System Startup

If the monitor completes the System Startup sequence, but fails to enter the user interface, it shows the **System software failure**. **Review error log for further details** window. Refer to [Figure 5-16](#).

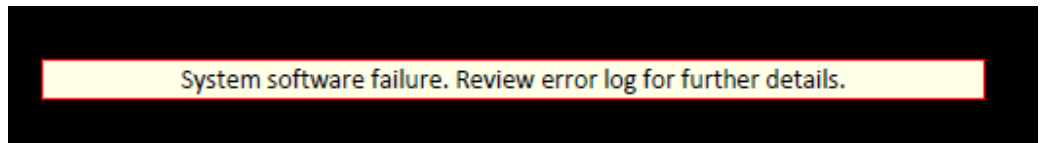

Figure 5-16 System Software Failure Window

This failure is caused when the (internal) USB Flash Drive on the Power Supply PCBA is corrupted or unformatted.

- 1 Access the **Boot Menu** (Refer to [Figure 5-3](#)). Select **E - error log functions...**
- 2 Scroll through the errors. Find the system software failure entry. If the error listed Refers to *Directory /slh0/usr/apps/ not found* (Refer to [Figure 5-17](#)), the internal USB Flash Drive is corrupted.

```
-----  
0: EVENT: 9/13/13 13:16:17: 0x00fe0400: MonInit  
System software failure.: Directory /slh0/usr/apps/ not found.  
0x2f2fb4 0xfe144 0x51787c  
-----
```

Figure 5-17 Error Log Entry for System Software Failure

- 3 Return to the **Boot Menu**, and then choose **f- format USB file system**. If the drive formats without errors, do a cold boot and retest the system. Data stored in the internal Flash Drive is lost during the format process, and must be reentered into the monitor. This data includes any Customized Trends created in the Clinical backend menu, and DNA™ (Citrix®) Application Server certificates.
- 4 If the system still fails to boot, replace in order:
 - 1 USB Flash Drive PCBA
 - 2 Power Supply PCBA
 - 3 CPU PCBA

This failure can also be caused when there is a version mismatch between the *app.bin* and the *fd_image.bin* sectors of the Flash ROM in the CPU. This only occurs during a software update by a Spacelabs Healthcare Field Service Engineer.

- 1 Access the **Boot Menu** (Refer to [Figure 5-3](#)). Select **E- error log functions...**
- 2 Scroll through the errors. Find the system software failure entry. If the error listed refers to *app.bin build ID does not match information found in fd_image.bin* (Refer to [Figure 5-18](#)), the



software must be reinstalled. Check that all three files associated with the software distribution (bootrom.bin, app.bin, and fd_image.bin) are the same version.

```
1: EVENT: 9/13/13 15:04:38: 0x00fe0400: MonInit
System software failure.:
app.bin build ID does not match information found in fd_image.bin.
0x2d72a4 0xfal90 0x4f5970
-----
2: EVENT: 9/13/13 15:04:38: 0x00fe0400: MonInit
System software failure.:
app.bin version does not match information found in fd_image.bin.
0x2d74e4 0xfal90 0x4f5970
-----
3: EVENT: 9/13/13 15:04:38: 0x00fe0400: MonInit
System software failure.:
app.bin checksum does not match information found in fd_image.bin.
0x2d74a0 0xfal90 0x4f5970
-----
```

Figure 5-18 Error Log Entry for System Software Failure

Monitor Fails Power-ON Diagnostics

Troubleshooting Method 1: Use the Touchscreen or Mouse

- 1 Display the **Boot menu** ([Boot Menu](#) on page 5-4).
- 2 Select **D - run diagnostics...**, then **i - Run an individual diagnostic...** Retest the previously indicated failure.
- 3 Upon verification of the failure, a message directs you to the field-replaceable unit that failed.

Troubleshooting Method 2: Use the Remote Terminal—Use When No Display is Present

Note:

This procedure can only be performed if the serial port is set for DIAGNOSTICS.

- 1 The **Serial Diagnostics** is an alternate method to access and control the **Boot** and **Diagnostics** menus when the display doesn't function. Attach a null-modem serial cable between the serial port on the monitor and a remote terminal. Configure the remote terminal for 9600 baud, no parity, 8 bits, 1 stop bit, and no flow control. When set for **Diagnostics** the serial port of the monitor is fixed at these settings.
- 2 Power ON the monitor.



- 3 To access the **Serial Diagnostic** menu, press CTRL+D during the 4, 3, 2, 1 countdown at system startup. The **Serial Diagnostics** menus are identical to the **Boot** and **Diagnostics** menus discussed earlier in this chapter, and are used in the same way to determine system faults.

Monitor Fails System Functions

Batteries/ Battery Charger

- 1 If the monitor does not recognize the presence of the battery or batteries, inspect the Battery Connector PCBA for any physical damage.
- 2 If the monitor recognizes batteries but fail to charge, replace in order:
 - 1 the battery or batteries
 - 2 the CPU PCBA

Touchscreen

If the display is present, but the touchscreen is unresponsive:

- 1 Calibrate the touchscreen either from the **Diagnostic** menus or from the **Biomed** menu using a mouse. Check the operation again.
- 2 Reseat the internal touchscreen cable between the Front-End assembly and the CPU.
- 3 Replace the Front-End assembly.
- 4 Replace the CPU PCBA. Recalibration of the touchscreen is necessary.

Module does not sign on when installed in an external module housing

If a module signs on when installed in the module bay of the monitor, but does not sign on when installed in the external module housing:

- 1 Check that the proper SDLC terminations are set on the module housing. Check that the proper power supply and cables for the module housing are used.
- 2 Replace the SDLC Backplane board in the module housing.





Module does not sign on when installed in the monitor for options A and B

- 1 If a Pod is available, connect it to the 91390. If the Pod signs on, replace the Interconnect PCBA.
- 2 If the Pod does not sign on, check that the +12vdc, -12vdc, and +5vdc voltages for the module and Pod are present. These voltages are accessible on the Pod connector pins. Refer to [Figure 5-19](#) on page 5-25:

Pod Interface Pinouts

Pin #	Function
PIN 1	SDLC_DAT+
PIN 2	SDLC_DAT-
PIN 3	SDLC_CLK+
PIN 4	SDLC_CLK +
PIN 5	GROUND
PIN 6	+5VDC
PIN 7	+12VDC
PIN 8	-12VDC

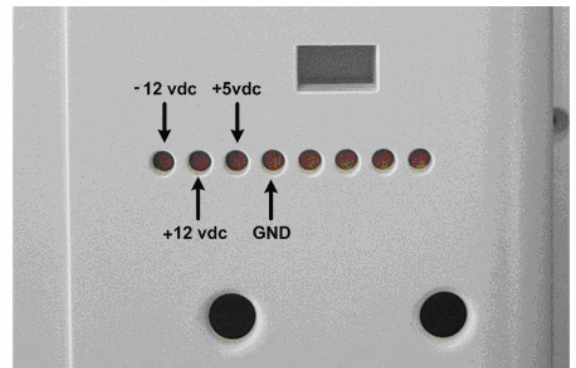

Figure 5-19 Voltage Test Points on Pod Interface Connector

- 3 If all three voltages are present, the problem is in the SDLC link. Replace in order: the Interconnect PCBA, and then the CPU PCBA.



Pod does not sign on

If a patient module installed in the module bay of the monitor signs on, but the Pod does not:

- 1 inspect the Pod Interface Cable and its connections between the Pod Interface and Interconnect PCBAs.
- 2 Replace parts in this order:
 - 1 Pod Interface Cable
 - 2 Pod Interface PCBA
 - 3 Interconnect PCBA

Module signs on but parameters do not function

If a module signs on when installed in the module bay of the monitor, but parameters such as ECG do not function:

- 1 Check that the +12vdc and -12vdc voltages are present on the Pod Interface PCBA. Refer to [Figure 5-19](#).
- 2 If either of the voltages are missing, replace in order:
 - a Interconnect PCBA
 - b CPU PCBA
- 3 If the +12vdc and -12vdc voltages are present, replace the Interconnect PCBA.

Ethernet

- 1 The green link LED lights up when the RJ45 cable is connected between the monitor and the network switch. The green link LED blinks, which indicates network activity.
- 2 If the green LED is not lit, inspect the cabling between the monitor and switch. Make sure that the Ethernet switch functions correctly. If the cabling and network infrastructure are good, replace the CPU PCBA.
- 3 If the green LED is lit, the Ethernet hardware in the monitor functions properly. If the monitor does not communicate with other monitors on the network, the problem is either:
 - in **Network Setup** menu
 - in the **Biomed** menu
 - a configuration issue in the network switch or infrastructure





External Alarm Relay for Option A

- 1 Check that the alarm cable is installed correctly in the 15-pin connector, .
- 2 Check that pin 9 on the connector has +12 V.
- 3 Check that the custom design is functional.
- 4 Replace the CPU PCBA if the problem persists.

Keyboard, Mouse, or Barcode Scanner

- 1 The barcode scanner must be set for keyboard entry mode.
- 2 Try another USB mouse or keyboard (there is no setup for the mouse or keyboard, either externally or internally). Cycle the power OFF and ON to make sure that the monitor detects the keyboard or mouse.

	Caution:
	Cycling power will lose patient data.

- 3 Check the USB connector or connectors for damage.
- 4 If the problem persists, replace in order:
 - 1 Monitor Dock PCBA
 - 2 CPU PCBA
 - 3 Connector PCBA

Touchscreen

If the touchscreen is unresponsive:

- 1 Perform a touchscreen calibration from the **Biomed** Menu using a mouse. Check the operation again.
- 2 Replace the Front-end assembly (touchscreen).
- 3 Replace the CPU PCBA.



Ethernet/Network

Check that the green LED on the network connector is lit showing “Link”, and blinks with network activity. If the link light is lit, the Ethernet connection between the monitor and the network switch is functional. Network communication issues related to monitoring functions can be due to incorrect network setup configuration in the monitor, or network infrastructure issues.

- 1 Check the network setup in the **Biomed** menu.
- 2 Check that the correct Monitor ID, Monitor Name, IP address, IP subnet, IP Gateway, Network Number, Network Size, and DSCP values are correct.
- 3 Contact the responsible IT department for network infrastructure issues.

External Alarm Relay/Nurse Alert for Option A

- 1 Check that the **Alarm Relay Setup** items under the **Alarms** tab in the **Biomed** menu are configured correctly.

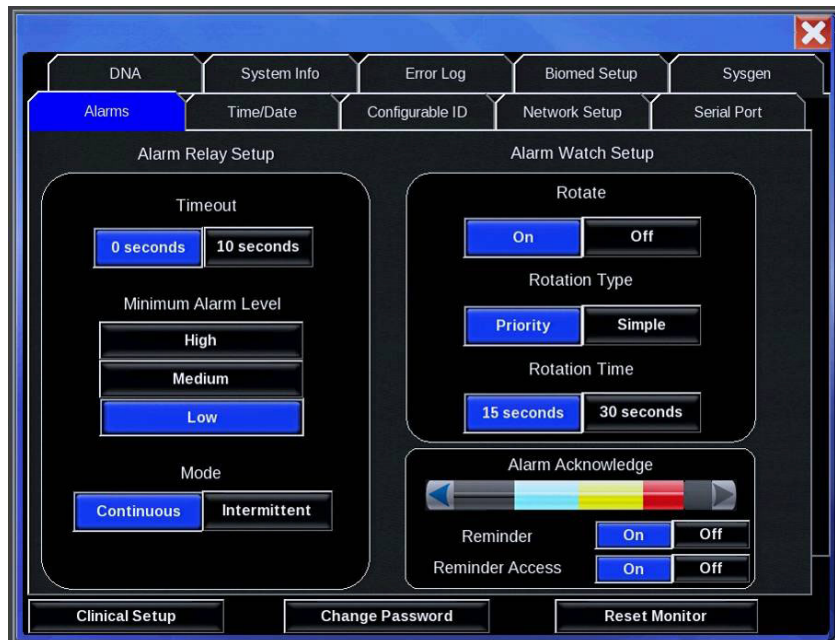

Figure 5-20 Alarm Relay Setup

- 2 Check that the alarm cable is securely connected to the 15-pin connector and the remote device.
- 3 Check that pin 9 on the connector has +12 VDC.
- 4 Check that the custom-design remote alarm device is functional.
- 5 Check and replace in order:
 - 1 CPU PCBA
 - 2 Connector PCBA





3 Mon-dock PCBA

Keyboard, Mouse, or Barcode Scanner

- 1 Try another USB mouse or keyboard. Try all four USB ports. Cycle the power OFF and ON to make sure that the monitor detects the keyboard or mouse.

	Caution:
	Cycling power causes all patient data in the monitor and parameter modules to be lost.

- 2 If any of the four USB ports fail, check and replace in order:
 - 1 CPU PCBA
 - 2 Connector PCBA
 - 3 Mon-dock PBCA





Parts

Overview

This chapter presents exploded views of monitor assembly and PCBA schematics for the monitor.

	Caution:
	Observe precautions when you handle electrostatic-sensitive devices!

Notes:

- *Never touch electrostatic-sensitive electronic components without following proper anti-static procedures, including the use of an ESD wrist band and mat. An electrostatic discharge from your fingers can permanently damage electronic components and cause latent failures.*
- *All static-sensitive electronic components are packaged in static-shielding bags. Keep the bag for repackaging the component to store it or return it to Spacelabs Healthcare for any reason.*



Parts List

Option A

Table 6-1 Field-Replaceable Parts Option A

Part Number	Description
650-1628-00	ASSY, FRONT END, COMPACT MONITOR, 91390
146-0142-00	BATTERY, NI2040SL24, 78WHR, 91390
407-0906-00	BRACKET, POD INTERFACE, 91390
407-0908-01	BRACKET, SPEAKER 91390
348-0312-00	BUMPER, POLYURETHANE, 0.75"OD, 0.16"THK, BLACK
175-1855-00	CABLE ASSY, ALARM LIGHTS, 91390
407-0899-00	BRACKET, SNAP GUIDE, DOCKING STATION
348-0859-00	BUMPER, 1/2" DIAMETER X 1/16" THICK, WHITE
175-1858-00	CABLE ASSY, DISPLAY POWER, 91390
175-1856-00	CABLE ASSY, DISPLAY, 91390
175-1857-00	CABLE ASSY, LED/IR/BUTTON, 91390
175-1860-00	CABLE ASSY, POD INTERFACE, 91390
175-1046-00	CABLE ASSY, SPEAKER, 90364 / 91387
344-0266-00	CLIP, BALL STUD
200-0492-00	COVER, DOCKING STATION, PAINTED, 91390
200-0489-00	COVER, DOCKING STATION, UNPAINTED, 91390
401-0868-00	DAMPER HINGE, 52MM, NYLON, 4.3 N-CM
010-1891-00	DRIVE NAND FLASH EMBEDDED USB, 2GB 5V
437-5112-00	ENCLOSURE, DOCKING STATION
437-5109-01	ENCLOSURE, REAR, 91390
119-0550-00	FAN ASSY, 91390
348-0862-00	GASKET, CONNECTOR, DOCK STATION
348-0837-00	GASKET, POD INTERFACE, 91390
367-0857-00	HANDLE, 91390
050-0675-00	KIT, 670-1522-02, SERVICE, 91390
334-6133-00	LABEL, MOD, S/N, OPT, REG, 91390
105-0307-00	LATCH, DOCKING STATION
388-1193-01	PCB, DOCKING STATION, COMPACT MONITOR, 91390
670-1555-00	PCBA, BAT CONNECT, COMPACT MONITOR, 91390





Table 6-1 Field-Replaceable Parts Option A (Continued)

Part Number	Description
670-1573-XX	PCBA, CPU, COMPACT MONITOR, 91390
670-1558-02	PCBA, DOCKING STATION, COMPACT MONITOR, 91390
670-1559-00	PCBA, INTERFACE PCBA, COMPACT MONITOR, 91390
670-1521-02	PCBA, MONITOR DOCKING, USB, 91390
670-1550-00	PCBA, POD INTERFACE, COMPACT MONITOR, 91390
670-1481-00	PCBA, SDLC INTERCONNECT, COMPACT MONITOR, 91390
134-0180-00 with DSB 134-0190-00 without DSB	PLUG, 91390
134-0181-00	PLUG, DOCKING CONNECTOR, 91390
134-0181-00	PLUG, DOCKING CONNECTOR, 91390
134-0182-00	PLUG, FINISHING, SCREW HOLE, 91390
134-0179-00	PLUG, RECORDER, 91390
366-4059-00	PUSH BUTTON, DOCKING STATION
161-0032-00	PWR CORD, DOM, 120V, 10A, 18AWG, 10', HOSP GRADE
119-0552-00	PWR SPLY, 90W, 20V, MEDICAL, 91390, ROHS
343-0414-01	RETAINER, HANDLE, 91390
214-1165-00	SPRING, COMPRESSION, 5.4MM OD, 24MM LONG, 4.36N
210-7118-00	WASHER, #8, .3/16ID, 7/16OD, STAINLESS STEEL

Table 6-2 Corrective Maintenance Kit Option A

Part Number	Description
050-0636-00 (KIT, CM, COMPACT, 91390)	
010-1891-00	DRIVE, NAND FLASH, EMBEDDED USB, 2GB, 5V
119-0550-00	FAN ASSY, 91390
119-0552-01	PWR SPLY, 90W, 20V, MEDICAL, 91390, ROHS
175-1046-00	CABLE ASSY, SPEAKER, 90364 / 91387
175-1855-00	CABLE ASSY, ALARM LIGHTS, 91390
175-1856-00	CABLE ASSY, DISPLAY, 91390
175-1857-00	CABLE ASSY, LED/IR/BUTTON, 91390
175-1858-00	CABLE ASSY, DISPLAY POWER, 91390
175-1860-00	CABLE ASSY, POD INTERFACE, 91390
650-1628-00	ASSY, FRONT END, COMPACT MONITOR, 91390
670-1481-00	PCBA, SDLC INTERCONNECT, COMPACT MONITOR, 91390
670-1521-02	PCBA, MONITOR DOCKING, USB, 91390

*Table 6-2 Corrective Maintenance Kit Option A (Continued)*

Part Number	Description
670-1522-02	PCBA,CONNECTOR BD,91390
670-1550-00	PCBA,POD INTERFACE,COMPACT MONITOR,91390
670-1555-01	PCBA,BAT CONNECT,COMPACT MONITOR,91390
670-1559-00	PCBA,INTERFACE PCBA,COMPACT MONITOR,91390
670-1573-00	PCBA,CPU W/PWR SPLY,COMPACT MONITOR,91390
004-0768-00	FOAM INSERTS, LARGE, CM KITS
004-0767-00	CASE, CM KIT, LARGE
064-2688-00	PROC,PACKAGING, INSTRC,9XXXX CM KITS
334-5707-23	LABEL,CASE ID,CM KIT 050-0636-00
334-5710-00	LABEL, CASE, CM KITS
334-6153-00	LABEL, CONTENTS LAYOUT, CM KIT 91390

Option B

Table 6-3 Field-Replaceable Parts Option B

Part Number	Description
650-1739-00	ASSY,FRONT END,COMPACT MONITOR,91390-B
146-0153-00	BATTERY,NF2040SL24,4.8AH
214-0423-01	BERYLLIUM,COPPER FINGERS,CLIP,SINGLE
391-0509-00	BLOCK,BATTERY SPACER,91390-B/C
004-0744-04	BOX,SHIPPING,90369/91369/91370/91367/91390
407-0906-00	BRACKET, POD INTERFACE, 91390
407-0801-00	BRACKET, SPEAKER RETAINER, 91393/4/5
407-0896-00	BRACKET,MODULE DOOR,91390
407-0939-00	BRACKET,SPEAKER,91390-B/C
348-0312-00	BUMPER,POLYURETHANE,.75"OD,.16THK,BLACK
175-1855-00	CABLE ASSY, ALARM LIGHTS, 91390
175-1858-00	CABLE ASSY, DISPLAY POWER, 91390
175-1856-00	CABLE ASSY, DISPLAY, 91390
175-1857-00	CABLE ASSY, LED/IR/BUTTON, 91390
175-1860-00	CABLE ASSY, POD INTERFACE, 91390
175-1046-00	CABLE ASSY,SPEAKER,90364 / 91387



Table 6-3 Field-Replaceable Parts Option B (Continued)

Part Number	Description
348-0910-00	C-FOLD GASKET,CONDUCTING ADHESIVE,10.2X10.9X12MM
441-0242-04	CHASSIS, 91390
344-0266-00	CLIP, BALL STUD
401-0868-00	DAMPER HINGE, 52MM, NYLON, 4.3 N-CM
202-0014-03	DOOR,MODULE CAGE,91390
437-5120-00	ENCLOSURE, REAR, 91390-B
119-0550-00	FAN ASSY, 91390
348-0848-00	GASKET, BALL STUD INTERFACE, 91390
348-0850-00	GASKET, EMI, CLIP-ON, BRIGHT TIN PLATE
348-0851-00	GASKET, EMI, NO-SNAG, BRIGHT TIN, 18"
348-0837-00	GASKET, POD INTERFACE, 91390
367-0857-01	HANDLE, 91390
342-0402-00	INSULATOR, CONNECTOR BOARD, 91390-B/C
342-0391-00	INSULATOR, CPU/INTERFACE, 91390
342-0389-00	INSULATOR, MONITOR DOCK BOARD, 91390
342-0414-00	INSULATOR,REAR ENCLOSURE, 91390-B/C
131-2450-00	JUMPER, 2PINS, ROHS
334-6133-01	LABEL,MOD,S/N,OPT,REG,91390
670-1658-01	PCBA, BATT CONN BRD WITH SWITCH, 91390
670-1647-00	PCBA, MODIFIED DOCK BRD, 91390-B/C
670-1645-01	PCBA,CONNECTOR, 91390
670-1573-02	PCBA,CPU W/PWR SPLY,COMPACT MONITOR,91390
670-1559-00	PCBA,INTERFACE PCBA,COMPACT MONITOR,91390
670-1550-00	PCBA,POD INTERFACE,COMPACT MONITOR,91390
670-1481-01	PCBA,SDLC CONN WITH TVS DIODES,91390
214-0329-00	PIN,HINGE,PCMS DOOR
134-0179-00	PLUG, RECORDER, 91390
119-0552-01	PWR SPLY,90W,20V,MEDICAL,91390,ROHS
343-0414-02	RETAINER, HANDLE, 91390
215-0375-00	SCR,M2.5X0.45X14,PNH,CR,STL,ZNC,PATCH
215-0261-00	SCR,M3X10,6MM OD,PNH,PH,SEMS DBL WSHR,CLR ZINC
215-0318-00	SCR,M3X6MM,PNH,PH,SQCN SEMS,SS



Table 6-3 Field-Replaceable Parts Option B (Continued)

Part Number	Description
361-4190-00	SHIM,POD INTERFACE,91390
214-0342-00	SPRING,TORSION,MODULE DOOR
211-0475-00	STND, 4-40 X3/16.25L HEX M-F STL, ZN W/ NYLOK
004-1074-00	TRAY,ACCESSORY,91390
004-0745-02	TRAY,SUSPENSION,TOP/BOTTOM 90369/91369/91370
210-7112-00	WASHER,TERMINAL CUP,#6,BRASS,ZNC
650-1740-00	ASSY,FRONT END,COMPACT MONITOR,91390-C
437-5121-00	ENCLOSURE, REAR, 91390-C
367-0857-01	HANDLE, 91390
175-1046-00	CABLE ASSY,SPEAKER,90364 / 91387
401-0868-00	DAMPER HINGE, 52MM, NYLON, 4.3 N-CM
348-0910-00	C-FOLD GASKET,CONDUCTING ADHESIVE,10.2X10.9X12MM
670-1644-00	PCBA,SDLC INTERCONNECT,91390

Table 6-4 Corrective Maintenance Kit Option B

Part Number	Description
050-0728-00 (KIT,CM,COMPACT,91390 OPTION B)	
010-1891-00	DRIVE, NAND FLASH, EMBEDDED USB, 2GB, 5V
119-0550-00	FAN ASSY, 91390
119-0552-01	PWR SPLY,90W,20V,MEDICAL,91390,ROHS
175-1046-00	CABLE ASSY,SPEAKER,90364 / 91387
175-1855-00	CABLE ASSY, ALARM LIGHTS, 91390
175-1856-00	CABLE ASSY, DISPLAY, 91390
175-1857-00	CABLE ASSY, LED/IR/BUTTON, 91390
175-1858-00	CABLE ASSY, DISPLAY POWER, 91390
175-1860-00	CABLE ASSY, POD INTERFACE, 91390
650-1739-00	ASSY,FRONT END,COMPACT MONITOR,91390-B
670-1481-00	PCBA,SDLC INTERCONNECT,COMPACT MONITOR,91390
670-1647-00	PCBA, MODIFIED DOCK BRD, 91390-B/C
670-1645-00	PCBA,CONNECTOR,91390
670-1550-00	PCBA,POD INTERFACE,COMPACT MONITOR,91390
670-1658-01	PCBA, BATT CONN BRD WITH SWITCH, 91390
670-1559-00	PCBA,INTERFACE PCBA,COMPACT MONITOR,91390





Table 6-4 Corrective Maintenance Kit Option B (Continued)

Part Number	Description
670-1573-02	PCBA,CPU W/PWR SPLY,COMPACT MONITOR,91390
004-0768-00	FOAM INSERTS, LARGE, CM KITS
004-0767-00	CASE, CM KIT, LARGE
064-2688-00	PROC,PACKAGING, INSTRC,9XXXX CM KITS
334-5707-23	LABEL,CASE ID,CM KIT 050-0636-00
334-5710-00	LABEL, CASE, CM KITS
334-6153-00	LABEL, CONTENTS LAYOUT, CM KIT 91390

Option C

Table 6-5 Field-Replaceable Parts Option C

Part Number	Description
650-1740-00	ASSY,FRONT END,COMPACT MONITOR,91390-C
146-0153-00	BATTERY,NF2040SL24,4.8AH
441-0242-04	CHASSIS, 91390
407-0896-00	BRACKET,MODULE DOOR,91390
407-0939-00	BRACKET,SPEAKER,91390-B/C
202-0014-03	DOOR,MODULE CAGE,91390
437-5121-00	ENCLOSURE, REAR, 91390-C
119-0550-00	FAN ASSY, 91390
348-0312-00	BUMPER,POLYURETHANE,.75"OD,.16THK,BLACK
367-0857-01	HANDLE, 91390
407-0801-00	BRACKET, SPEAKER RETAINER, 91393/4/5
215-0375-00	SCR,M2.5X0.45X14,PNH,CR,STL,ZNC,PATCH
211-0475-00	STND, 4-40 X3/16.25L HEX M-F STL, ZN W/ NYLOK
215-0261-00	SCR,M3X10,6MM OD,PNH,PH,SEMS DBL WSHR,CLR ZINC
215-0318-00	SCR,M3X6MM,PNH,PH,SQCN SEMS,SS
214-0423-01	BERYLLIUM,COPPER FINGERS,CLIP,SINGLE
214-0329-00	PIN,HINGE,PCMS DOOR
119-0552-01	PWR SPLY,90W,20V,MEDICAL,91390,ROHS
343-0414-02	RETAINER, HANDLE, 91390
175-1046-00	CABLE ASSY,SPEAKER,90364 / 91387
401-0868-00	DAMPER HINGE, 52MM, NYLON, 4.3 N-CM



Table 6-5 Field-Replaceable Parts Option C (Continued)

Part Number	Description
214-0342-00	SPRING,TORSION,MODULE DOOR
342-0389-00	INSULATOR, MONITOR DOCK BOARD, 91390
342-0402-00	INSULATOR, CONNECTOR BOARD, 91390-B/C
342-0391-00	INSULATOR, CPU/INTERFACE, 91390
348-0910-00	C-FOLD GASKET,CONDUCTING ADHESIVE, 10.2X10.9X12MM
334-6133-01	LABEL,MOD,S/N,OPT,REG,91390
348-0850-00	GASKET, EMI, CLIP-ON, BRIGHT TIN PLATE
175-1858-00	CABLE ASSY, DISPLAY POWER, 91390
175-1856-00	CABLE ASSY, DISPLAY, 91390
175-1857-00	CABLE ASSY, LED/IR/BUTTON, 91390
004-0744-04	BOX,SHIPPING,90369/91369/91370/91367/91390
004-0745-02	TRAY,SUSPENSION,TOP/BOTTOM 90369/91369/91370
004-1074-00	TRAY,ACCESSORY,91390
348-0851-00	GASKET, EMI, NO-SNAG, BRIGHT TIN, 18"
670-1658-01	PCBA, BATT CONN BRD WITH SWITCH, 91390
670-1645-01	PCBA,CONNECTOR, 91390
670-1573-02	PCBA,CPU W/PWR SPLY,COMPACT MONITOR,91390
670-1644-00	PCBA,SDLC INTERCONNECT,91390
670-1647-00	PCBA, MODIFIED DOCK BRD, 91390-B/C
670-1559-00	PCBA,INTERFACE PCBA,COMPACT MONITOR,91390
391-0509-00	BLOCK,BATTERY SPACER,91390-B/C
342-0414-00	INSULATOR,REAR ENCLOSURE, 91390-B/C

Table 6-6 Corrective Maintenance Kit Option C

Part Number	Description
050-0729-00 (KIT,CM,COMPACT,91390 OPTION C)	
010-1891-00	DRIVE, NAND FLASH, EMBEDDED USB, 2GB, 5V
119-0550-00	FAN ASSY, 91390
119-0552-01	PWR SPLY,90W,20V,MEDICAL,91390,ROHS
175-1046-00	CABLE ASSY,SPEAKER,90364 / 91387
175-1856-00	CABLE ASSY, DISPLAY, 91390
175-1857-00	CABLE ASSY, LED/IR/BUTTON, 91390
175-1858-00	CABLE ASSY, DISPLAY POWER, 91390





Table 6-6 Corrective Maintenance Kit Option C (Continued)

Part Number	Description
650-1740-00	ASSY,FRONT END,COMPACT MONITOR,91390-C
670-1644-00	PCBA,SDLC INTERCONNECT,91390
670-1647-00	PCBA, MODIFIED DOCK BRD, 91390-B/C
670-1645-00	PCBA,CONNECTOR,91390
670-1559-00	PCBA,INTERFACE PCBA,COMPACT MONITOR,91390
670-1573-02	PCBA,CPU W/PWR SPLY,COMPACT MONITOR,91390
004-0768-00	FOAM INSERTS, LARGE, CM KITS
004-0767-00	CASE, CM KIT, LARGE
064-2688-00	PROC,PACKAGING, INSTRC,9XXXX CM KITS
334-5707-23	LABEL,CASE ID,CM KIT 050-0636-00
334-5710-00	LABEL, CASE, CM KITS
334-6153-00	LABEL, CONTENTS LAYOUT, CM KIT 91390
670-1658-01	PCBA, BATT CONN BRD WITH SWITCH, 91390

Table 6-7 Service Kits

Part Number	Description
050-0644-00	ASSEMBLY KIT, MODULE DOOR ASSEMBLY, QUBE
050-0643-00	KIT, BATTERY DOOR ASSEMBLY, QUBE
050-0636-00	KIT,CM,COMPACT,91390



Assembly Drawings and Schematics

The following assembly drawings and schematics are included as part of this manual.

Table 6-8 Assembly Drawings and Schematics

Title	Drawing Part Number	Drawing Number
System Block Diagram	N/A	1
Assembly Parts List	N/A	2
Monitor Assembly Drawings	N/A	3

Table 6-9 Assembly Kit

Part Number	Description
670-1521-01-X	PCBA, MONITOR DOCKING, USB/DSB, 91390, EXCHANGE
670-1558-01	PCBA, DOCKING STATION, COMPACT MONITOR, 91390
670-1572-00	PCBA, DOCKING STATION, 91390





Glossary

The following terms appear in this manual:

802.11d

The 802.11d standard is a supplement to the 802.11 standard. It allows international use of local 802.11 networks so that stations may convey information on frequency ranges that are dependent on what is permitted in the country where the device is operating.

ADC

Analog to digital converter

AP

Access Point

ASCII

American Standard Code for Information Interchange. A standardized way of assigning numerical codes to characters and control codes.

ATE

Automated test equipment used in performance testing of printed circuit assemblies.

Baud rate

Data transfer rate associated with serial data transfers, typically between personal computers via modems. Example: 9600 bits per second.

Bit map

Technique of drawing computer images by mapping the image in RAM.

BNC

A push and twist connector that allows a fast connect/disconnect of thin coaxial cable.

Boot ROM

Programmed ROM devices that contain basic data required to start a digital system at power up. This data generates instructions to the processor, allowing a limited set of start-up instructions.

CA

Certificate Authority. A trusted third party entity which issues digital certificates for use by other parties. A CA provides authentication of certificates that it generates on request from certificate users. It generates a CA root certificate that does not need authentication and is the basis for authenticating the certificates generated by the CA. The CA also publishes a list of certificates whose authentication has been revoked.

CFI

Common Flash Interface

Checksum

A count of the number of bits in a transmission unit, which is included with the transmission unit, so that a receiver can check to see whether the same number of bits arrived.

CMOS RAM

Battery backed up device used to store configuration information such as node name, node ID, or bed names.

**CODEC**

An integrated circuit that performs communications data conversion

Composite video

Video display signal containing both video and sync information.

Compact Flash card adapter

A memory card that uses flash memory to store data

CPU

Central Processing Unit

CR/LF

Carriage Return / Line Feed

CTS

Clear To Send signal used in communication protocols.

DB9

“D” shaped, 9-pin connector of either male or female gender.

DB15

“D” shaped, 15-pin connector of either male or female gender.

DB15HD

High-density, “D” shaped, 15-pin connector with DB9 shell and footprint.

DB26

“D” shaped, 26-pin connector of either male or female gender.

DECNET

A proprietary network protocol.

Degauss

Process of removing a magnetic charge from a material. Color CRT screens are most susceptible to this type of charge creating “purity” problems.

DER

Distinguished Encoding Rules. This is a binary message format based on the ASN.1 International Standard.

DHCP

Dynamic Host Configuration Protocol, a networking protocol.

DIN

A standard for cable connectors.

DNS

Domain Name System. Translates domain names into IP addresses.

Dot pitch

Method of comparison used to determine the quality of a display. It indicates the angle and proximity each dot has to the other.

DRAM

Dynamic Random Access Memory used for computer memory systems.

DSUB

A type of cable connector.

DTR

Data Terminal Ready signal used in communications protocol.

EAP

Extensible Authentication Protocol. This is a message format standard (Point-to-Point Protocol (PPP)) used for authentication of user identities.

EAP-LEAP

Lightweight EAP. A Cisco-developed EAP authentication method with features such as dynamic WEP keys and mutual authentication between a wireless client and a Radius server.

EAP-PEAP

Protected EAP. An 802.1X authentication type where server-side authentication happens using digital certificates and client-side authentication happens via another 802.1X authentication type, such as EAP MSCHAPV2.

EEPROM

Electrically Erasable Programmable Read Only Memory. The portion of the monitor’s memory which holds sysgen information and hardware configurations.

EMI

Electromagnetic Interference generated by repetitive signals such as microprocessor clocks that can interfere with other devices or two-way radio communications.

EPP

Enhanced Parallel Port



**ESD**

Electrostatic Discharge. High voltage potentials carried on the body that are generated by walking across a carpeted floor or caused by low humidity environments, which can be discharged into an electronic device, damaging it.

Ethernet

The LAN technology that uses CSMA/CD physical access method and 10/100 Mbps digital transmission. The forerunner of the IEEE802.3 CSMA/CD standard.

Flash ROM

A type of EEPROM that can be erased and reprogrammed in blocks instead of one byte at a time.

FED

Front End Device - Project Salish acronym that defines the parameter front ends including ECG, SpO2, IBP, ETCO2, NIBP etc.

Ferrite

RF (radio frequency) lossy material used for EMI suppression.

FPGA

Field-Programmable Gate Array.

Flexport System Interface

Spacelabs Healthcare device that communicates via RS232 with other manufacturer's equipment.

FRU

Field-replaceable unit

FTP

File Transfer Protocol. The protocol for exchanging files over the Internet.

GDS

Global Data System

GPCM

General purpose chip select machine, used as an interface between the processor and memory

GPIO

General Purpose Input Output

High level output

Analog signals supplied through a separate connector for use with external equipment.

HRESET

Hardware reset

IC

Integrated circuit

I/O

Input/Output port or device

IEEE

A U.S. professional organization active in the creation, promotion, and support of communications specifications and standards.

IP Address

Internet Protocol Addresses used in TCP/IP. Identifies packet origin/destination.

IRTS

Infrared Touchscreen. One of the user interfaces to the Spacelabs Healthcare monitoring system.

ISA

Industry Standard Architecture. A standard bus (computer interconnection) architecture

JTAG port

A test access port used for testing printed circuit boards

Kernel

The center of a computer operating system, which provides basic services for all other parts of the operating system

LAN

Local Area Network. A network system that provides a relatively small area with high speed data transmission at a low error rate.

LCD

Liquid crystal display

LED

Light emitting diode

Light transmittance

Measure of light levels as measured at the face of the CRT.

Lithium

Material used to construct a high energy battery for use in CMOS backed circuits.

**MAC address**

Media Access Control address. A unique identifier attached to networking equipment.

Mb it

Measurement used for RAM devices. Example: a 4 Mbit device will contain 4 megabits of data.

MDC

Management Data Clock

MDIO

Management Data Input/Output

MII

Media Independent Interface

Monitor Name

Unique name entered into the monitor, identifying it to all other monitors on the network.

Monitor ID

Unique identification entered into the monitor, allowing an Ethernet address to be assigned.

NiMH

Nickel metal hydride battery; a type of rechargeable battery

Node

A device that is connected as part of a computer network

NTSC

National Television Standard used for U.S. television video formats.

NVRAM

Non-Volatile RAM

OEM

Original equipment manufacturer

OTPROM

One Time Programmable Read Only Memory device

PAL

International television video format

Packets

The units of information used in computer networks that use packet switching

PCB or PCBA

Printed Circuit Board or PCB Assembly

PC Card

A card designed to be inserted into devices to enable extra functions

PCI

Peripheral Component Interconnect

PCMCIA

Personal Computer Memory Card International Association. Refers to the type of type I card that adds ROM or RAM and can be exchanged without rebooting the system.

PEM

Privacy Enhanced Mail format. This is a Base 64 encoded text version of the DER format that is used for certificate files.

PFAIL

Power Failure notification line used to notify the CPU of an imminent AC power failure.

PIM

Protocol Interdependent Multicast. Used to route multicast PKIs on the network. Contains two modes: sparse and dense.

PIXEL

Smallest unit displayed on a CRT. One PIXEL equals a single dot on the display.

PHY

Physical layer

PI

Patient Identifier

PKI

Public Key Infrastructure. In cryptography, a PKI is an arrangement that binds public keys with respective user identities by means of a certificate authority (CA). The user identity must be unique for each CA. The binding is established through the registration and issuance process, which, depending on the level of assurance the binding has, may be carried out by software at a CA, or under human supervision. The PKI role that assures this binding is called the Registration Authority (RA). For each user, the user identity, the public key, their binding, validity conditions, and other attributes are made unforgettable in public key certificates issued by the CA.



**Plenum rated**

Cable that must be used where toxic gases created by heat during a fire could not be tolerated. The plenum term refers to the return air path for an air conditioning system.

PM

Preventive Maintenance

PMC

PCI Mezzanine Card

Primary printer

Network printer that has first priority in receiving print requests.

Printer Name

Name placed into the monitor to allow the user to send hard copy recordings to a specific network printer.

Privileged access

Monitor operations not accessible to all users. A password is required to access these functions.

PS/2

IBM standard

PSK

Pre-Shared Key. Used with WPA security to encrypt the data prior to transmission. A PSK pass phrase or PSK key configuration is used in place of a username or password.

PVC

Poly Vinyl Chloride used in production of non-plenum cables.

RAMDAC

Digital-to-Analog Converter with memory that converts digital video to analog video.

RGB

Red, Green, Blue

RISC

Reduced Instruction Set Computing

ROM

Read Only Memory

RTC

Real Time Clock

RTGL

Real Time Graphics Library

RTS

Ready-To-send signal used in communications protocols.

RXD

Receive Data. Used in communications protocols.

SDLC

Synchronous Data Link Control. Used for communication between the monitor and external devices such as modules, telemetry housings or Flexport interfaces.

Secondary printer

Network printer where printing requests made at a bedside or central are sent to if a primary printer is busy.

SIMM

Single In-line Memory Module

SMA

Shared Memory ASIC

SRAM

Static RAM (CMOS RAM)

SSID

Service Set Identifier. A sequence of characters attached to all packets on a wireless network to identify each packet as part of that network.

SSL

Secure Socket Layer. Predecessor to TLS.

Stop bits

Quantity of bits used to discontinue transfer block in serial communications.

Subnet Mask

Part of an IP address that is allocated for a subnetwork.

Subnet Name

Unique subnetwork name identifying logically separated networks.

SuperCap

A type of capacitor

**Sysgen**

Spacelabs Healthcare's method to enable purchased options.

Tap block plug

Dummy plug used to seal up an unused hole tapped into a coaxial cable on an Ethernet system.

Tap block

Device used to "tap" into an active or inactive Ethernet coax cable.

TCP/IP

Transmission Control Protocol/Internet Protocol used as an underlying mechanism for moving packets of information between different machines on a local or wide-area network.

TFT

Thin-film transistor; a technology used in liquid crystal displays

TLB

Translation Lookaside Buffer

TLS

A protocol that allows secure internet communications. TLS involves three basic phases: 1) peers negotiate the encryption algorithm; 2) encryption keys are exchanged; 3) symmetric cipher encryption and message authentication.

Terminator

A resistive load attached to each end of a coaxial cable segment, or at a single end of an SDLC line. The function of a terminator is to match the characteristic impedance of the cable.

Transceiver (Ethernet)

Device located on coax cable or line powered attaching monitors to the network. These devices are bi-directional.

TTL

Time to live. The allowed number of hops the IP packet can take across network devices.

TXD (Transmit Data)

Transmit Data. Used in communications protocols.

UART

Universal Asynchronous Receiver/Transmitter; a microchip that controls the computer's interface to its attached serial devices

UPS

Uninterruptible Power Supply. Used to hold power up until AC mains are restored.

USB

Universal Serial Bus

UUT

Unit Under Test

VBA

Video Bus Array

VBB

Lithium Voltage Battery Backup

VPP

Voltage used for programming devices

VRAM

Video RAM

WEP

Wired Equivalent Privacy. A security protocol used to secure wireless networks.

WLAN

Wireless Local Area Network.

WDT

Watch Dog Timer

WPA

WiFi Protected Access. An 802.11i IEEE standard protocol that provides a means to establish secure communications on WiFi networks.

XON/XOFF

Used in communication definitions





Appendix A – Electromagnetic Compatibility

Electromagnetic Emissions

Emission Test	Compliance	Electromagnetic Environment
RF emissions CISPR 11	Group 1 Class B	The <i>monitor</i> uses RF energy only for internal function. Therefore, RF emissions are very low and are not likely to cause any interference in nearby electronic equipment.
Harmonic emissions IEC 61000-3-2	Complies	Device Class A
Voltage fluctuations/ flicker IEC 61000-3-3	Complies	



Electromagnetic Immunity

Note:

The monitor is intended for use in the electromagnetic environment specified below. The customer, or user, of the monitor should ensure that it is used in such an environment.

Immunity Test	IEC 60601 Test Level	Compliance Level	Electromagnetic Environment
Electrostatic discharge (ESD) IEC 61000-4-2	±6 kV contact ±8 kV air	8 kV contact 15 kV air	Floors should be wood, concrete, or ceramic tile. If floors are covered with synthetic material, the relative humidity should be at least 30%.
Electrical fast transient/burst IEC 61000-4-4	±2 kV for power supply lines ±1 kV for input/output data lines	±2 kV for power supply lines ±1 kV for input/output data lines	Module performance may differ with each host monitor/module housing platform. Worst-case performance encountered under lab conditions: 500 V — immune. 1 kV — affected; perceptible noise on RESP waveform; no change in data. 2 kV — affected; excessive noise on RESP waveform; erroneous breaths per minute rate. If affected, refer to .
Surge IEC 61000-4-5	±1 kV differential mode ±2 kV common mode	1 kV differential mode 2 kV common mode	Mains power quality should be that of a typical commercial or hospital environment.
Voltage dips, short interruptions, and voltage variations on power supply input lines IEC 61000-4-11	<5% U_T (>95% dip in U_T for 0.5 cycle) 40% U_T (60% dip in U_T for 5 cycles) 70% U_T (30% dip in U_T for 25 cycles) <5% U_T (>95% dip in U_T for 5 seconds)	<5% U_T (>95% dip in U_T for 0.5 cycle) 40% U_T (60% dip in U_T for 5 cycles) 70% U_T (30% dip in U_T for 25 cycles) <5% U_T (>95% dip in U_T for 5 seconds)	Mains power quality should be that of a typical commercial or hospital environment. The <i>monitor</i> automatically switches to internal battery operation during mains power interruptions.
Power frequency (50/60 Hz) magnetic field IEC 61000-4-8	3 A/m	60 A/m	Power frequency magnetic fields should be at levels characteristic of a typical location in a typical commercial or hospital environment.

Note: U_T is the AC mains voltage prior to application of the test level. All power line immunity tests were performed at 120 VAC/60 Hz and 230 VAC/50 Hz.



Separation Distances

Note:

The monitor is intended for use in an electromagnetic environment in which radiated RF disturbances are controlled. The customer, or user, of the monitor can help prevent electromagnetic interference by maintaining a minimum distance between portable and mobile RF communications equipment (transmitters) and the monitor, as recommended below, according to the maximum output power of the communications equipment.

Recommended Separation Distances Between Portable and Mobile RF Communications Equipment and the Monitor (Always evaluate electronic equipment on site before use)

Immunity Test	IEC 60601 Test Level	Compliance Level	Electromagnetic Environment
Conducted RF IEC 61000-4-6	3 Vrms 150 kHz to 80 MHz	20 V r.m.s 1 kHz sine 80% AM	Portable and mobile RF communications equipment should be used no closer to any part of the monitor, including cables, than the recommended separation distance calculated from the equation applicable to the frequency of the transmitter. Recommended separation distance: $d = \left[\frac{3.5}{V_1} \right] \sqrt{P}$ 150 kHz to 80 MHz $d = \left[\frac{3.5}{E_1} \right] \sqrt{P}$ 80 MHz to 800 MHz $d = \left[\frac{7}{E_1} \right] \sqrt{P}$ 800 MHz to 2.5 GHz Where <i>P</i> is the maximum output power rating of the transmitter in watts (W) according to the transmitter manufacturer, and <i>d</i> is the recommended separation distance in meters (m). Field strengths from fixed RF transmitters, as determined by an electromagnetic site survey,* should be less than the compliance level in each frequency range.**  Interference may occur in the vicinity of equipment marked with the following symbol. IEC 60417-5140: Non-ionizing electromagnetic radiation.
Radiated RF IEC 61000-4-3	3 Vm 80 MHz to 2.5 GHz	20 V/m 1 kHz sine 80% AM	

* Field strengths from fixed transmitters, such as base stations for radio (cellular/cordless) telephones and land mobile radios, amateur radio, AM and FM radio broadcast, and TV broadcast cannot be predicted theoretically with accuracy. To assess the electromagnetic environment due to fixed RF transmitters, an electromagnetic site survey should be considered. If the measured field strength in the location in which the monitors are used exceeds the applicable RF compliance level above, the monitors should be observed to verify normal operation. If abnormal performance is observed, additional measures may be necessary, such as reorienting or relocating the monitors.

** Over the frequency range 150 kHz to 80 MHz, field strengths should be less than [*V*₁] V/m.



Rated maximum output power of transmitter (watts)	Separation distance according to frequency of transmitter (meters)		
	150 kHz to 80 MHz	80 MHz to 800 MHz	800 MHz to 2.5 GHz
0.01	0.02	0.02	0.04
0.1	0.06	0.06	0.1
1	0.2	0.2	0.4
10	0.6	0.6	1.1
100	1.8	1.8	3.5

Notes:

- *At 80 MHz and 800 MHz, the separation distance for the higher frequency range applies.*
- *These guidelines may not apply in all situations. Electromagnetic propagation is affected by absorption and reflection from structures, objects, and people.*

Mitigation

- Move AC line connection to another AC outlet/power phase.
- Position power cable and power supply away from other devices and their power and data cables.
- Fold excess cable length in a noninductive bundle. Do not coil or roll long cables.
- Change power supplies.
- Power the monitor/module housing through an isolation transformer.





Appendix B – Symbols

The following list of international and safety symbols describes all symbols used on Spacelabs Healthcare products. No one product contains every symbol.

Note:

Graphic elements of certain keys and symbols may vary between product lines.



HELP Key



HELP (Explain Prior Screen) Key



MONITOR SETUP Key















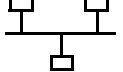

REMOTE Key

















TRENDS Key







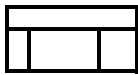











	RECORD Key
	Dynamic Network Access (DNA) Key
	SPECIAL FUNCTIONS Key
	NORMAL SCREEN Key
	SAVE Key
	No Network Connection
	Network Connection
	Do Not Connect to Network
	No Connection to Intesys® Clinical Suite (ICS)
	Compression
	Magnifying Glass
	File Cabinet
	List of Rooms
	Printer
	Service Message





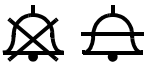







	PREVIOUS MENU Key
	
	HOME Key
	Arrows
	On Direction
	ON — Power Connection to Mains
	ON — Part of the Instrument Only
	ON Position for Push Button Power Switch
	OFF — Power Disconnection from Mains
	OFF Position for Push Button Power Switch
	OFF — Part of the Instrument Only
	Partial ON/OFF
	ON/OFF
	Standby
	STANDBY Key Power ON/OFF Key
	Keyboard Connection

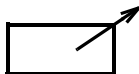













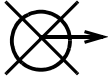

	Mouse Connection
	PAUSE or INTERRUPT
	START/STOP Key
	START/STOP
	STOP or CANCEL Key
	CONTINUE Key
	ENTER Key
	Delete
	Nurse Alert Interface
	ALARM SUSPEND/TONE RESET Key
	ALARMS Key
	Alarm, General
	Alarm Reset
	Alarm Audio ON
	Alarm Audio OFF
	Alarm Audio Paused



	Low Priority Alarm
	Medium Priority Alarm
	High Priority Alarm
	Alarms Paused
	Alarm OFF
---	Parameter below measurement range
+++	Parameter above measurement range
???	Parameter measurement indeterminate
	Indicator — Remote Control
	PRINT REPORT Key
	Normal Screen
	Clock/Time Setting Key
	Slow Run
	Activate Recorder for Graphics
	Reset















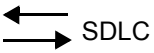

	START (NIBP) Key
	Power Indicator LED
	Activate Telemetry Recorder
	Output (Non-terminated)
	Data Input/Output
	Input
	No Output (Terminated)
	Indicator — Local Control
	Indicator — Out of Paper
	Recorder Paper
	Menu Keys
	Waveform/Parameter Keys
	Return to Prior Menu
	Monitor Setup Select Program Options
	Set Initial Conditions Menu





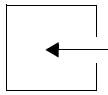
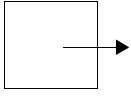







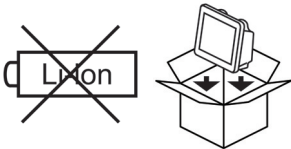

	<p>Access Special Function Menu</p>
	<p>Return Unit to Monitor Mode</p>
	<p>Keypad</p>
	<p>Serial Port 1</p>
	<p>Serial Port 2</p>
	<p>Serial Port</p>
	<p>Auto Mode (NIBP)</p>
	<p>External Marker Push Button Connection</p>
	<p>Arterial Pulse</p>
	<p>Gas Exhaust</p>
	<p>Video Output</p>
	<p>Television; Video Display</p>
	<p>Video Output, Primary</p>
	<p>Video Output, Secondary</p>
	<p>Enlarge, Zoom</p>

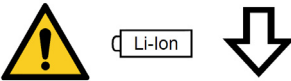

	Input/Output
	PCMCIA Card
	Touchscreen, External
	Universal Serial Bus
	SDLC Port
	Hard Drive
	Antenna
	Electrocardiograph or Defibrillator Synchronization
	Microphone
	Foot Switch
	Audio Output, Speaker
	Event
	Gas Sampling Port
	Gas Return Port
	Battery Replace only with the appropriate battery.











	Battery Status
	Battery Replace only with the appropriate battery.
	Low Battery
	Replace only with the appropriate battery. (+ / - signs may be reversed)
	Battery off. Shipping and service mode.
	Battery on. Regular operating mode.
	Check battery switch on bottom of unit.
	All batteries should be disposed of properly to protect the environment. Lithium batteries should be fully discharged before disposal. Batteries such as lead-acid (Pb) and nickel-cadmium (Ni-Cd) must be recycled. Please follow your internal procedures and or local (provincial) laws regarding disposal or recycling.
	This symbol indicates that the waste of electrical and electronic equipment <i>must not</i> be disposed as unsorted municipal waste and must be collected separately. Please contact an authorized representative of the manufacturer for information concerning the decommissioning of your equipment.
	Caution - hazardous voltages. To reduce risk of electric shock, do not remove the cover or back. Refer servicing to a qualified field service engineer (U.S.A.). DANGER - High Voltage (International)
	Protective Earth Ground
	Replace Fuse Only as Marked





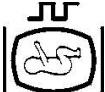

	Power supply jack polarity. (+ / - signs may be reversed)
	Alternating Current
	Both Direct and Alternating Current
	Functional Earth Ground
	Fuse
	Equipotentiality Terminal
	Direct Current
	Input Power. Use only Spacelabs Power Supply (P/N 119-0527-xx).
	AC/DC Input
	Loop Filter
	Audio Output, Speaker
	IEC 60601-1 Type B equipment. The unit displaying this symbol contains an adequate degree of protection against electric shock.
	IEC 60601-1 Type BF equipment which is defibrillator-proof. The unit displaying this symbol is an F-type isolated (floating) patient-applied part which contains an adequate degree of protection against electric shock, and is defibrillator-proof.
	IEC 60601-1 Type BF equipment. The unit displaying this symbol is an F-type isolated (floating) patient-applied part providing an adequate degree of protection against electric shock.
	IEC 60601-1 Type CF equipment. The unit displaying this symbol is an F-type isolated (floating) patient-applied part providing a high degree of protection against electric shock, and is defibrillator-proof.





	IEC 60601-1 Type CF equipment. The unit displaying this symbol is an F-type isolated (floating) patient-applied part providing a high degree of protection against electric shock.
	IEC 60601-1 Class II equipment, double-isolated. The unit displaying this symbol does not require a grounded outlet.
	Warning: Do not modify this equipment without authorization of the manufacturer.
	Operates on Non-Harmonized Radio Frequencies in Europe
	Adult Noninvasive Blood Pressure (NIBP)
	Fetal Monitor Connection (Analog)
	Fetal Monitor Connection RS-232 (Digital)
	Physiological Monitor Connection RS-232 (Digital)
	Noninvasive Blood Pressure (NIBP), Neonate

	Symbol Set, Adult/Pediatric Cuff Sizes
	Symbol Set, Neonatal Cuff Sizes

	NIBP Cuff, Neonatal 1
	NIBP Cuff, Neonatal 2
	NIBP Cuff, Neonatal 3



NIBP Cuff, Neonatal 4



NIBP Cuff, Neonatal 5



NIBP Cuff, Single Hose



NIBP Cuff, Dual Hose

THIS SIDE TO PATIENT















NIBP Cuff, Surface Applied to Patient

CHILDNIBP Cuff, Child Size
(12 to 19 cm)**CHILD, LONG**NIBP Cuff, Child Size, Long
(12 to 19 cm)**SMALL ADULT, LONG**NIBP Cuff, Small Adult Size, Long
(17 to 25 cm)**SMALL ADULT**NIBP Cuff, Small Adult Size
(17 to 25 cm)**ADULT, LONG**NIBP Cuff, Adult Size, Long
(23 to 33 cm)**LARGE ADULT, LONG**NIBP Cuff, Large Adult Size, Long
(31 to 40 cm)**LARGE ADULT**NIBP Cuff, Large Adult Size
(31 to 40 cm)**ADULT**NIBP Cuff, Adult Size
(23 to 33 cm)**INFANT**NIBP Cuff, Infant Size
(8 to 13 cm)**NEONATAL 1**NIBP Cuff, Neonatal 1 Size
(3 to 6 cm)











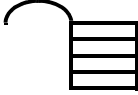

	NIBP Cuff, Neonatal 2 Size (4 to 8 cm)
	NIBP Cuff, Neonatal 3 Size (6 to 11 cm)
	NIBP Cuff, Neonatal 4 Size (7 to 13 cm)
	NIBP Cuff, Neonatal 5 Size (8 to 15 cm)
	NIBP Cuff, Thigh Size (38-50 cm)
	NIBP Cuff, Nylon Material
	NIBP Cuff, Soft Material
	NIBP Cuff, Vinyl Material
	Quantity
	Place Artery Symbol and Arrow over Brachial or Femoral Artery
	eIFU = electronic Instructions for Use (CD-ROM or website) is available
	Consult Instructions For Use
	Follow Instructions For Use















	Warning About Potential Danger to Human Beings (Consult Accompanying Documents)
	Caution About Potential Danger to a Device (Consult Accompanying Documents)
Note	Note
	Keep Dry
	Indoor Use Only
	Environmental Shipping/Storage Altitude Limitations
	Environmental Shipping/Storage Temperature Limitations
	Fragile
	Handle with Care
	This Way Up
	Up Arrow
	Down Arrow
	Environmental Shipping/Storage Humidity Limitations
	Humidity limitation
	Atmospheric pressure limitation



	Open Padlock
	Closed Padlock
	Happy Face
	Sad Face
	PVC-Free (Polyvinyl Chloride)
	Do Not Reuse; Single Use Only
	Reusable
IPX1	Drip-Proof
IPX7	Unit can withstand accidental immersion in one meter of water for up to 30 minutes
	Reference Number or Order Number
	Use by date [YYYY-MM-DD]
	Recycle
	Non Sterile
	Latex-Free
	Date of Manufacture



	Manufacturer
	Radio transmitting device; elevated levels of non-ionizing radiation
	A CE mark certifies that a product has met EU health, safety, and environmental requirements, which ensure consumer safety.
	XXXX is the European Notified Body number. 0123 is the number for TÜV SÜD Product Service GmbH, München, Germany.
	Canadian Standards Association Approved
	Does not contain hazardous substances — Europe
	Does not contain hazardous substances — China
	Batch Code
	Nellcor Oxisensor II Compatible
	Novametrix Compatible
	Spacelabs TruLink Compatible
	Nellcor OxiMax Compatible
	Spacelabs Compatible





UL recognized component in Canada and United States



Nellcor OxiMax Compatible



Masimo SET Compatible

ABBREVIATIONS USED AS SYMBOLS ARE SHOWN BELOW.

1 - 32	Access Codes 1 Through 32
AIR	Air
A	Amperes
ANT 1	Diversity Antenna System 1
ANT 2	Diversity Antenna System 2
Arr1	Arrhythmia Net 1
ArrNet2	Arrhythmia Net 2
avDO₂	Arterial/Venous Oxygen Difference
CaO₂	Arterial Oxygen
CH	EEG, EMG, or ECG Channel
ch	EEG Channels - CH1, CH2, CH3, CH4 EMG Channel - CH5
cmH₂O	Centimeters of Water
C.O.	Cardiac Output
CO	Cardiac Output
CvO₂	Venous Oxygen
CO2	Carbon Dioxide
CO₂	Carbon Dioxide
DIA	Diastolic
dia	Diastolic
ECG	Electrocardiogram
ecg	Electrocardiogram
EEG	Electroencephalogram
eeg	Electroencephalogram
EMG	Electromyogram
emg	Electromyogram
ESIS	Electrosurgical Interference Suppression



EXT	External
FECG	Fetal Electrocardiogram
FHR1 FHR2	Fetal Heart Rate, Channel 1 Fetal Heart Rate, Channel 2
GND gnd	Ground
Hz	Hertz
Hgb	Hemoglobin
HLO hlo	High-Level Output
Multiview	Multi-Lead Electrocardiogram
N₂O	Nitrous Oxide
NIBP nibp	Noninvasive Blood Pressure
O₂AV	Oxygen Availability
O₂	Oxygen
PaO₂	Partial Pressure of Arterial Oxygen
PRESS press PRS	Pressure
PvO₂	Partial Pressure of Mixed Venous Oxygen
Ref.	Oxygen reference gas port
RESP resp	Respiration
SDLC	Synchronous Data Link Control
SN	Serial number
MDL	Model number
OPT	Option
SPO2 SpO2 SpO₂ SaO₂	Arterial Oxygen Saturation as Measured by Pulse Oximetry





SVO2 SvO2 SvO₂	Mixed Venous Oxygen Saturation
SYS sys	Systolic
T1 T2 T3 T4	Temperature 1 Temperature 2 Temperature 3 Temperature 4
TEMP temp	Temperature
UA	Uterine Activity or Umbilical Artery
UV	Umbilical Venous
VAC	Vacuum Connection
VO₂	Oxygen Consumption
V	Volts
W	Watts

