



# Eppendorf Research<sup>®</sup> pro

Instruction Manual · Mode d'emploi · Manual de Instrucciones

**eppendorf**

## Contents / Sommaire / Índice

### Part A / Section A / Parte A

Instruction Manual .....	2
Mode d'emploi .....	30
Manual de Instrucciones .....	58

### Part B / Section B / Parte B

Programming / Programas .....	86
Ordering Information / Informaciones para pedido .....	100

ependorf and ependorf Research are registered trademarks.  
Registered trademarks are not marked in all cases with <sup>TM</sup> or <sup>®</sup> in this manual.

Research pro pipettes are manufactured under U.S. Patent No. 4,671,123; 4,905,526; 5,187,990

No part of this publication may be reproduced without the prior permission of the copyright owner  
Copyright© 1999 Ependorf – Netheler – Hinz GmbH, Hamburg

<b>1</b>	<b>Safety precautions and applicational limitations</b> .....	<b>3</b>
	Handling.....	3
	Care and maintenance.....	3
	Battery.....	3
<b>2</b>	<b>Technical data</b> .....	<b>4</b>
	Battery.....	4
	Power unit.....	4
<b>3</b>	<b>Startup</b> .....	<b>5</b>
3.1	Delivery package.....	5
3.2	Inserting the battery.....	5
3.3	Charging the battery.....	5
<b>4</b>	<b>Operating principle</b> .....	<b>6</b>
4.1	Display and keypad.....	6
4.2	Unit's functions.....	7
	Ejector with extension.....	7
	Hook on the hand rest.....	7
	Contact surface on the rear of the pipette.....	7
	Acoustic signals.....	7
<b>5</b>	<b>Operation</b> .....	<b>8</b>
5.1	Mode of operation.....	8
5.2	Essential operating information.....	8
	Aspirating and dispensing speeds.....	9
	Loading gels.....	9
5.3	Pipetting in the standard mode.....	10
5.4	Pipetting with separate blow-out (Blow = BLO).....	11
5.5	Pipetting with separate rinsing (Rinse = RNS).....	12
5.6	Reverse Pipetting (RP).....	13
5.7	Pipetting with the MAN option.....	14
5.8	Pipetting with a preselected fixed volume (FIX).....	16
5.9	Dispensing (DIS).....	18
5.10	Notes on the programs.....	19
5.10.1	Example for programming pipetting in the program level.....	21
5.11	Device parameters.....	22
5.11.1	Changing the calibration (CAL).....	23
5.11.2	Information on initialization (INI).....	25
<b>6</b>	<b>Care, sterilization and maintenance</b> .....	<b>26</b>
6.1	Care.....	26
6.2	Sterilization.....	26
	Lower part of multi-channel model.....	26
	Lower part of single-channel model.....	27
6.3	Maintenance.....	27
<b>7</b>	<b>Troubleshooting</b> .....	<b>28</b>

# 1 Safety precautions and applicational limitations

Before using the Research pro for the first time, please read the entire operating manual. To guarantee problem-free, safe operation of the pipette, it is essential to observe the following points:

## Handling

- Use the Research pro only when a pipette tip is attached.
- Do not lay down the Research pro when a filled pipette tip is attached.
- After liquid has been aspirated, press the Actuate key only when you are sure that the liquid shall be dispensed correctly.
- When the pipette is switched on and when the Reset key is pressed, the piston may move. Please ensure beforehand that the liquid in the pipette tip shall be dispensed correctly.
- Emergency stop: A moving piston can be stopped by pressing the Reset key.
- When using infectious, radioactive, toxic and other solutions which may pose health risks, please observe the safety precautions laid down for your country.
- Do not use the Research pro in a potentially explosive environment or with potentially explosive chemicals.
- When using organic solvents and aggressive chemicals, please check their compatibility with the pipette tip (PP) and pipette.
- When using solutions with physical properties which deviate greatly from those of water, carry out the procedure for checking the dispensing volume, as described in Sec. 5.11.1.
- When using multi-channel models of the Research pro, rotate the multi-channel adapter in the permitted direction of the arrow only (see Sec. 6, "Maintenance").
- Operate the Research pro at temperatures between 15 °C and 40 °C only and at a humidity of max. 80 % at a temperature up to 31 °C.
- When using Filtertips or 200 µl tips with the 300 µl pipette, activate the volume restriction option (see Sec. 5.11).

## Care and maintenance

- Do **not** clean the display or any of the labeling using acetone or aggressive solutions.
- Do not allow any liquid to enter the device.
- Repairs may be carried out by authorized service personnel only.
- Use original spare parts and accessories (battery, pipette tips) only.

## Battery

- Charge up the battery before operating the device for the first time (see Sec 3).
- Charge the battery in the pipette only, using the charging adapter or the charging stand and the original power unit.
- If a flashing battery symbol appears in the display, stop dispensing and charge the battery.
- When changing the battery, do not allow the battery to come into contact with any metallic surfaces.
- Dispose of used batteries as special waste, in accordance with legal stipulations to this effect.
- Never charge the Research pro without a battery.
- Before storing the Research pro for a long period, be sure to remove the battery.

## 2 Technical data

Volume range $\mu\text{l}$	Step size $\mu\text{l}$	Color code	Pipette tip	Test volume $\mu\text{l}$	Inaccuracy %	Imprecision %
<b>Single-channel</b>						
0.5 – 10	0.01	gray	20 $\mu\text{l}$	1 10	$\pm 2.5$ $\pm 1.0$	$\leq 1.8$ $\leq 0.4$
5 – 100	0.1	yellow	200 $\mu\text{l}$	10 100	$\pm 2.0$ $\pm 0.8$	$\leq 1.0$ $\leq 0.2$
20 – 300	0.5	yellow	300 $\mu\text{l}$	30 300	$\pm 2.5$ $\pm 0.6$	$\leq 0.7$ $\leq 0.2$
50 – 1000	1	blue	1000 $\mu\text{l}$	100 1000	$\pm 3.0$ $\pm 0.6$	$\leq 0.6$ $\leq 0.2$
100 – 5000	10	violet	5 ml	500 5000	$\pm 3.0$ $\pm 0.6$	$\leq 0.6$ $\leq 0.15$
<b>Multi-channel</b>						
0.5 – 10	0.01	gray	20 $\mu\text{l}$	1 10	$\pm 5.0$ $\pm 2.0$	$\leq 3.0$ $\leq 0.8$
5 – 100	0.1	yellow	200 $\mu\text{l}$	10 100	$\pm 2.0$ $\pm 0.8$	$\leq 2.0$ $\leq 0.25$
20 – 300	0.5	yellow	300 $\mu\text{l}$	30 300	$\pm 2.5$ $\pm 0.6$	$\leq 1.0$ $\leq 0.25$
50 – 1200 *	5	green	1.25 ml	120 1200	$\pm 6.0$ $\pm 1.2$	$\leq 0.9$ $\leq 0.3$

The technical data is valid only when the Research pro is used with Eppendorf pipette tips. The multi-channel data is valid for eight- and twelve-channel pipettes.

\* The 50 – 1,200 model is available as an eight-channel version only.

Test conditions in accordance with DIN 12650 for piston-stroke pipettes with an air cushion by means of a standardized fine balance with a moisture trap. Number of determinations: 10; degassed distilled water, 20 °C – 25 °C  $\pm$  0.5 °C; maximum speed; standard operation; prewetted pipette tip; dispensing onto inside of tube; due to possible evaporation, check volumes  $\leq$  10  $\mu\text{l}$  immediately after aspiration.

### Battery

Nickel-metal hydride battery pack, 1,200 mAh / 2.4 V with reversible overcurrent and overtemperature protection. Charging time: approx. 9.5 hours for a fully discharged battery. Overcharging protection with the pipette.

### Power unit

Input voltage, country-specific: 230 V  $\pm$  10 %, 50/60 Hz; 115 V  $\pm$  10 %, 60 Hz;  
100 V  $\pm$  10 %, 50/60 Hz

Output voltage: 9 V DC; 200 mA (1.8 VA)

Technical specifications subject to change!

## 3 Startup

### 3.1 Delivery package

The Research pro is supplied as a single-channel, eight-channel or twelve-channel pipette for different volume ranges. The pipette is delivered with or without a charging adapter, depending on the order number. **If the pipette is ordered without an adapter, a charging stand for one or four pipettes is required.** If this charging stand is not already available in the lab, it must be ordered separately. According to the type of order, the delivery package contains the following:

- Charging adapter with connected power unit or, if necessary, charging stand with separate power unit
- Special tool(s) according to the pipette type
- Operating manual with measuring protocol and CE conformity assurance document
- Ni-MH battery pack
- For multi-channel pipettes: Reagent reservoir for liquid aspiration

### 3.2 Inserting the battery

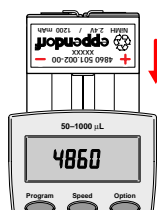

Using your thumb and forefinger, take hold of the lid of the battery compartment on the rear of the pipette and remove it by tilting it to the side and pulling it upwards. Insert the battery pack (see diagram).

Close the lid of the battery compartment. If the battery has been inserted incorrectly, the lid cannot be closed properly. The positive and negative poles of the battery should not come into contact with any metallic objects outside the pipette. When the battery is inserted, the Research pro carries out a test routine. This takes approximately 15–20 seconds.

The battery must be fully charged before the device is used for the first time.

### 3.3 Charging the battery

The battery is charged in the pipette. Charging may only be carried out using the charging adapter supplied or the charging stand with the original power unit. Do not try to recharge a pipette if the battery is not installed! A new battery does not attain its full capacity until two or three complete charging/discharging cycles have been completed.

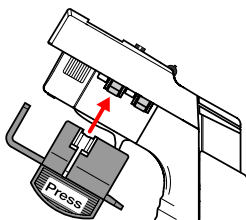

Before recharging, please compare your voltage requirements with the voltage specifications on the plug-in unit.

For charging purposes, the charging adapter is placed upon the Research pro. Alternatively, the Research pro can be placed in the charging stand.

During the start and termination of the charging process, "CON" appears briefly on the left-hand side of the display. The display is switched on during the charging process. The battery symbol appears in a rolling form. During charging, the Dispensing function

is frozen. When the charging process has finished, the battery symbol appears in the display without moving. When the pipette has been fully charged, it may remain in the charging stand. To increase the charging capacity, the battery should occasionally be discharged until the flashing battery symbol appears. To avoid a total discharge, the battery should be removed from the Research pro during extended periods of non-use (e.g. several months). In this case, all data remains stored.

# 4 Operating principle

## 4.1 Display and keypad

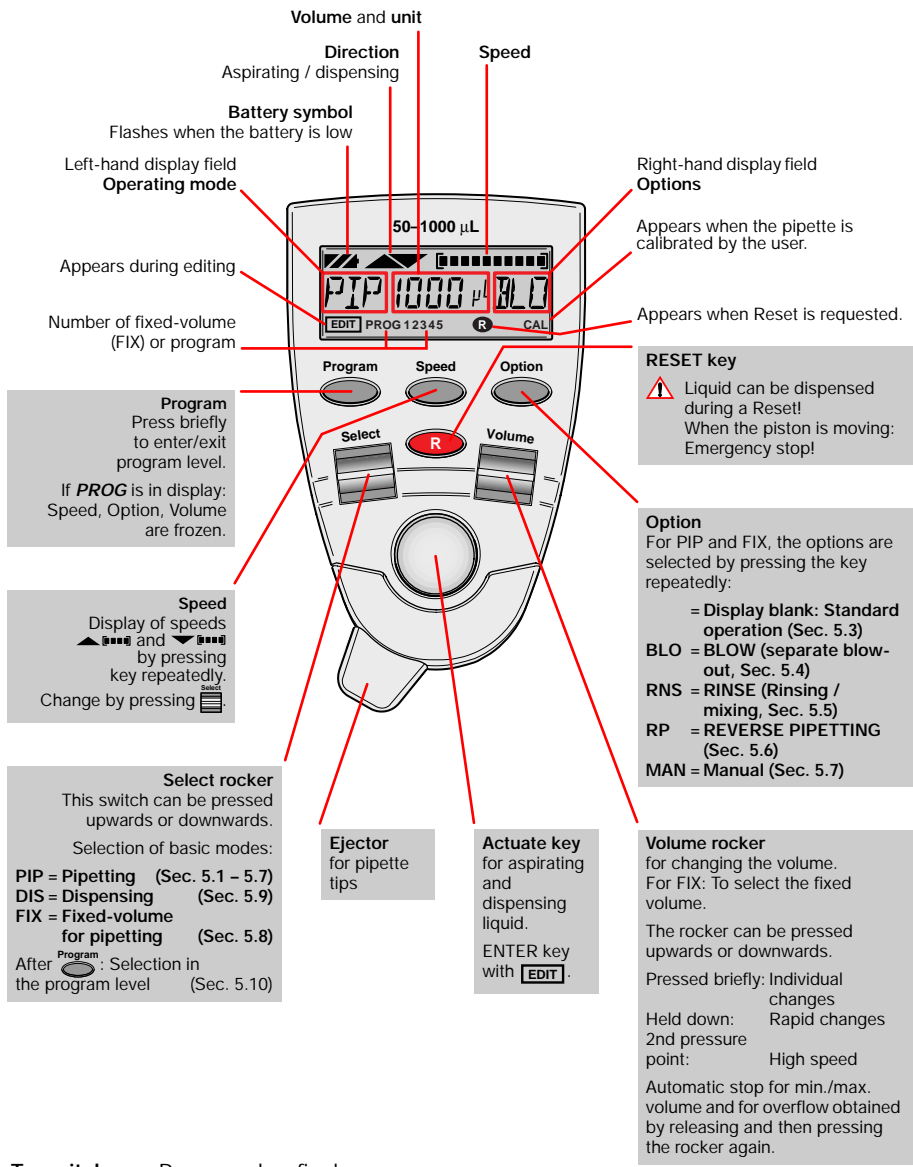

**To switch on:** Press any key firmly  
**To switch off:** Automatically after 10 min of non-use

## 4 Operating principle

### 4.2 Unit's functions

The Research pro is a microprocessor-controlled pipette which executes the piston movement with the aid of a stepper motor. The power supply is a rechargeable nickel-metal hydride battery.

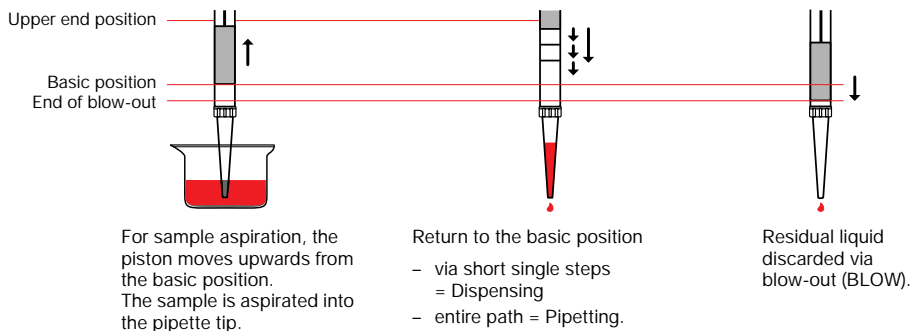

Dispensing and Reverse Pipetting require a different basic position than that for Pipetting. The request to change the basic position is indicated in the display by **Ⓡ**.

### Ejector with extension

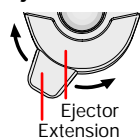

The force translation of the ejector for pipette tips ensures that tips are ejected very easily. The extension can be individually adjusted to accommodate left- and right-handed users as well as different hand sizes. Select the desired setting by simply sliding the extension into the position as required.

### Hook on the hand rest

Loosening the screw enables the hook on the rear of the pipette to be adjusted to suit all hand sizes. This can be done easily with a small Phillips screwdriver.

### Contact surface on the rear of the pipette

Both upper surfaces are required for charging the nickel-metal hydride battery.

The lower surfaces are the data interfaces for the Service Department.

The contact to the charging adapter or the charging stand cannot be confused with any other contacts.

### Acoustic signals

Certain signals assist the user for different operations:

- Short signal to acknowledge that the keypad has been pressed.
- Slightly higher tone to indicate that the function for which the key has been pressed cannot be executed.
- Louder tone to indicate that a piston movement has ended.
- Longer tone to indicate that a specific sequence of steps (e.g. Dispensing) has ended.
- Louder tone to indicate an error message.

The acoustic signals are a great help when you are familiarizing yourself with the operating procedure of the Research pro. They can also be switched off if required (see Sec. 5.11).

## 5 Operation

### 5.1 Mode of operation

If the display of the Research pro is dark, the pipette is switched on by pressing any key firmly. If the pipette has not been used for a long period, a motor reset is executed after it has been switched on.

Attach an Eppendorf pipette tip to the Research pro. The color coding of the Actuate key corresponds to the color code of the racks for pipette tips. The dispensing liquid is aspirated into the pipette tip.

*When the 200  $\mu$ l tips are used together with the 300  $\mu$ l pipette and when Filtertips are used, the volume restriction option must be activated in the device parameters (Sec. 5.11).*

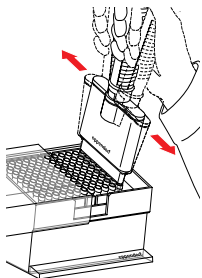

The liquid which is to be aspirated is taken from a suitable vessel. When multi-channel pipettes are used, the reagent reservoir vessel is recommended.

Before commencing pipetting activities with multi-channel pipettes, turn the adapter so that it is facing in the same direction as the arrows on the adapter. During rotation, a small "click" indicates that the adapter is positioned correctly.

In addition to the description found in the subsequent sections 5.3 – 5.11, the following general procedure takes place:

Attach the pipette tip from the rack. Slight force may be used if necessary.

With multi-channel pipettes, the pressure on the outer pipette tips is increased by tilting the pipette slightly.



When aspirating liquid, immerse the pipette tip vertically – and as little as possible – into the liquid. Following aspiration, remove the pipette tip from the liquid after the acoustic signal has been emitted. If air bubbles have been aspirated, this process must be repeated.



**Never lay the pipette down when the tip is filled!**



If necessary, carefully remove any external wetting from the pipette tip. To dispense liquid, position the pipette tip against the side of the aspirating vessel (as shown in the illustration).

Depending on the type of problem (carryover, contamination), discard the pipette tip after that by pressing the Eject key, attach a new tip and reaspirate liquid.

### 5.2 Essential operating information

The following sections contain step-by-step explanations of the operating procedure. It is essential to work through these sections with the pipette in your hand. The volume shown in the display information contained in the operating manual does not necessarily correspond to the volume range of your pipette.

#### Reset



If a Reset is requested in the display, this Reset is always accompanied by a piston movement. For this reason, please ensure that any residual liquid in the pipette tip is dispensed beforehand! A Reset can also be used to empty the pipette tip and to end an operating process. If you quit an input field during programming (e.g. changing the speed) using Reset, the changes which have been made are not stored. The Reset button can also act as an emergency stop function.

## 5 Operation

5

Operation

**Motor reset** If the Reset key (R) is held down until the piston movement begins and **R** appears in the display, a motor reset is carried out. This motor reset guarantees that the piston movement is correct. This reset routine lasts for approximately 10 seconds.

**Program** The Research pro has two operating levels. The basic modes for pipetting (PIP and FIX) and dispensing (DIS) are accessed in the first level by pressing the Select rocker. **PROG** appears in the display by pressing the "Program" key. You are now in the second level. Using the Select rocker, select from the five available program slots (Sec. 5.10). This level can be quit by pressing the "Program" key briefly. **PROG** disappears from the display.

Please refer to the following illustrations when going through each operation.



An Actuate key which has been pressed briefly is light.



An Actuate key which has been held down is dark.



If the piston movements appear in the display without any volumes, this indicates a process which is **not** connected to liquid aspiration or dispensing.

### Aspirating and dispensing speeds

The selected speed can be viewed by pressing the Speed key several times. The speed is changed as follows:

			Display and selection of aspirating speed.	
				Display and selection of dispensing speed.

\* This procedure does not have to be completed using the Speed key. Any key, with the exception of Reset, may be used. At the same time, pressing the key executes the respective key function.

The direction of the arrow for speed flashes in this input field.  
The speed can be altered before every dispensing or aspiration.

### Important!

High speeds [■■■■■■■■] have a much lower current consumption than low speeds.

### Loading gels







With the 10  $\mu$ l and 100  $\mu$ l Research pro, the lowest speeds for liquid dispensing ▼ are ideal for loading gels. To enable users to work rapidly and with a low electricity consumption, the highest possible speed for liquid aspirating ▲ should be used. Depending on the task at hand, gels can be loaded in the Standard mode (Sec. 5.3) or by using the BLO (Sec. 5.4) or MAN (Sec. 5.7) options.

## 5 Operation

















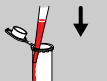

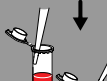
### 5.3 Pipetting in the standard mode

In the Standard mode, blow-out is executed automatically when liquid is dispensed. The standard mode is recommended for rapid series pipetting with aqueous solutions.

#### Programming

		<p>If <b>PROG</b> appears in the display: Press the  key briefly until <b>PROG</b> disappears.</p>
		<p>Volume selection (here: 800 µl). The volume rocker has two pressure points for up and down.</p>
		<p>If necessary, press the Option key several times. In the Standard mode, the display remains blank in this case.</p>

#### Pipetting procedure

			<p>Liquid is aspirated. If <b>R</b> appears in the display: Press the  key briefly.</p>
			<p>Liquid is dispensed with blow-out.</p>
<h4>Alternative pipetting procedure</h4>			
			<p>If the Actuate key is held down when liquid is dispensed, the device returns  to the basic position when the key is released.</p>
			<p>Before releasing the key, remove the pipette tip from the solution in order to prevent any solution from being aspirated unintentionally.</p>
 			
			<p>The pipette is now once again ready to aspirate.</p>

## 5 Operation

### 5.4 Pipetting with separate blow-out (Blow = BLO)

BLO is recommended for use with liquids with a high wetting power or with liquids which are prone to the formation of foam (e.g. solutions containing protein). The residual liquid is dispensed by pressing the Actuate key a second time.

#### Programming

Select



If **PROG** appears in the display: Press the  key briefly until **PROG** disappears.

Volume



Volume selection (here: 800 µl). The volume rocker has two pressure points for up and down.

Option Option tion ...



If necessary, press the Option key several times. BLO is selected for blow-out.

#### Procedure



Liquid is aspirated. If **R** appears in the display: Press the  key briefly.

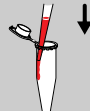

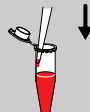

Liquid is dispensed.

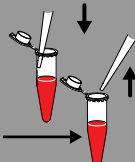

Blow-out: Delayed dispensing of residual liquid.

#### Alternative blow-out procedure



If the Actuate key is held down during the blow-out, the return  does not take place until the key has been released.











The pipette is now once again ready to aspirate.

# 5 Operation







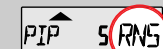







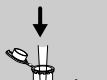

## 5.5 Pipetting with separate rinsing (Rinse = RNS)

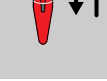
Rinsing (RNS) is recommended for sample volumes below 10 µl. RNS is suitable for mixing the dispensing volume and the specimen liquid when large volumes are used. It is strongly recommended to use the "max. speed" setting.

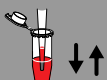
### Programming

		<p>If <b>PROG</b> appears in the display: Press the  key briefly until <b>PROG</b> disappears.</p>
		<p>Volume selection (here: 5 µl). The volume rocker has two pressure points for up and down.</p>
   		<p>If necessary, press the Option key several times. RNS is selected for rinsing.</p>

### Procedure









			<p>Liquid is aspirated. If <b>R</b> appears in the display: Press the  key briefly.</p>
			<p>Rinsing/mixing takes place three times after liquid has been dispensed.</p>
			<p>Alternative mixing procedure</p>
			<p>If the Actuate key is held down when liquid is dispensed, mixing takes place until the key is released.</p>
			<p>Return to basic position by pressing the key when device is not immersed in the liquid.</p>
			<p>The pipette is now once again ready to aspirate.</p>

## 5 Operation











### 5.6 Reverse Pipetting (RP)

RP is recommended for solutions with a high viscosity or with a slightly higher vapor pressure. "Reverse Pipetting" is liquid aspiration with a blow-out. The liquid is dispensed without a blow-out. If Filtertips are used, please observe the volume restriction (Sec. 5.11).





#### Programming

		<i>If <b>PROG</b> appears in the display:</i> Press the  key briefly until <b>PROG</b> disappears.
		Volume selection (here: 800 µl). The volume rocker has two pressure points for up and down.
   ...		If necessary, press the Option key several times. RP is selected.

#### Procedure

		 ↑	Aspiration of liquid with blow-out. <i>If <b>R</b> appears in the display:</i> Press the  key briefly.
		 ↓	Liquid is dispensed.
			Blow-out is discarded. If necessary, replace the tip.
			Pipette is once again ready to aspirate liquid with blow-out.

#### Alternative procedure for dispensing and aspirating

		 ↓	If the Actuate key is held down when liquid is dispensed, the next liquid aspiration without blow-out takes place when the key is released. The liquid from the blow-out will remain in the tip and may continue to be used.
		 ↑	

## 5 Operation











### 5.7 Pipetting with the MAN option

Note: The MAN (manual) option is the equivalent of operation with a mechanical piston-stroke pipette. Liquid is aspirated and dispensed only when the Actuate key is held down. The volume display increases the number of applications available in comparison to a mechanical pipette:









1. Aspirating: Measuring a small, unknown amount of liquid via aspiration into the pipette tip. If necessary, dilute the liquid to the defined end volume by aspirating additional liquids. Liquids can be separated by aspirating air bubbles. The display shows the total volume.
2. Dispensing: Titration is carried out. The amount of liquid dispensed appears in the display. There is no blow-out.

Setting lower speeds is strongly recommended.

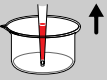
#### Programming

		<p>If <b>PROG</b> appears in the display: Press the  key briefly.</p>
		<p>Volume selection (here: 1,000 µl). The volume rocker has two pressure points for up and down.</p>
   		<p>If necessary, press the Option key several times. MAN is selected.</p>

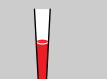
#### Carrying out liquid aspiration

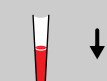
			<p>Liquid is aspirated. The aspirated liquid appears in the display. If  appears in the display and no volume is shown: Press the  key briefly.</p>
			<p>The direction is changed using the volume rocker.</p>
			<p>Volume correction, e.g. for removing an air bubble.</p>

Continued on next page

## 5 Operation

5

Operation



The direction is changed again using the volume rocker. This change of direction can be repeated without restriction.



A defined end volume has been reached. A special acoustic signal is emitted. Dispensing is carried out by pressing the key again.

### Carrying out dispensing/titration



Aspirate the defined total volume by holding down the Actuate key.

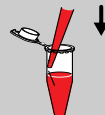

When the key is pressed briefly: The amount of liquid dispensed appears in the display.

or



Total amount of liquid is dispensed. A special acoustic signal is emitted. Blow-out is not executed. Blow-out can be actuated by pressing the **R** key.



Press the key again to aspirate liquid.

### Note:

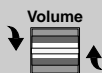















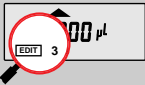

The direction can also be changed during dispensing. The volume display changes after the Actuate key has been pressed.

## 5 Operation

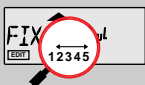



### 5.8 Pipetting with a preselected fixed volume (FIX)

FIX is used to rapidly set and recall five frequently used pipetting volumes. Five FIX volumes are predefined in the pipette. FIX volumes can be changed via programming.

#### Programming FIX fixed volumes

		<p>If <b>PROG</b> appears in the display: Press the  key briefly.</p>
		<p><b>Hold down</b> the Program key until EDIT appears. The volume flashes.</p>
		<p>Select the memory slot using the Select rocker.</p>
		<p>Using the Volume rocker, select the volume for the memory slot (here: 5).</p>
		<p>Select the next memory slot for purposes of changing the volume.</p>
		<p>Define the next volume (here: memory slot 3).</p>
		<p>The program is ended by pressing the  key. EDIT and the flashing volume disappear from the display.</p>

or

















			<p>The selected volume is aspirated. Programming is ended. EDIT and the flashing volume disappear from the display. If <b>R</b> appears in the display: Press the  key briefly.</p>
---	---	---	--

## 5 Operation

5

Operation

### Selecting a fixed volume (with option and speed)

		<i>If <b>PROG</b> appears in the display:</i> Press the  key briefly.	
		Select from the five FIX volumes.	
   ...		Press the Option key repeatedly until the desired option appears (BLO, RNS, RP, MAN or nothing).	
			Display and selection of aspirating speed.
	 		Display and selection of dispensing speed.

Note: The option and speeds selected are applicable for all fixed volumes.

It is possible to store the pipetting volume with speed and option by using **Prog** (Sec. 5.10).

#### Procedure

















The procedure depends on the option selected. Information on the procedure according to the option selected is contained in Sections 5.3 to 5.7.

## 5 Operation











### 5.9 Dispensing (DIS)

During this procedure, the aspirated liquid is dispensed in defined partial steps. As with "Reverse Pipetting", slightly more liquid is aspirated than is necessary for the sum of the dispensing steps. When Filtertips are used, please observe the volume restriction (Sec. 5.11).

#### Programming

		<i>If <b>PROG</b> appears in the display:</i> Press the  key briefly.		
		Select the volume per dispensing step. In the right-hand side: max. dispensing steps per filling of the pipette tip (here: 20; 1,000 µl pipette).		
  		If necessary, the number of dispensing steps can be minimized. The dispensing steps are flashing during Select.		
			Display and selection of aspirating speed.	
				Display and selection of dispensing speed.









#### Procedure

			↑ Aspiration of total amount of liquid (here: > 600 µl). <i>If <b>R</b> appears in the display:</i> Press the  key briefly.
			↓ First dispensing step is executed.
			↓ Second dispensing step is executed.

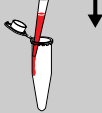
## 5 Operation

5

Operation

			Last dispensing step is executed. Here: special acoustic signal is emitted.
			Blank step with special acoustic signal.
			Blow-out is discarded. No dispensing step.  If the Actuate key is held down during the final blow-out, the device does not return ▲ to the basic position until the key is released.
			Pipette is once again ready to aspirate liquid.

### 5.10 Notes on the programs

To reach the programming level, the  key must be pressed **briefly**.

**PROG** appears in the display together with a memory slot number from **1 – 5**.

With the aid of the  rocker, five programs can be shown in the left-hand side of the display.

After programming has been completed, the procedure **can no longer** be changed by repeatedly pressing the keys or the volume rocker.

To program the five memory slots, it is possible to select from seven different program sequences:

#### PIP = Pipetting

As per PIP outside the program level. The complete sequence with volume, option and speeds is programmed in one memory slot.

#### SP = Sequential Pipetting

Up to five different pipettings can be linked up to each other. Volume, option and speeds are defined for each pipetting sequence.

#### DIS = Dispensing

As per DIS outside the program level. The complete procedure is programmed in one memory slot with dispensing volume, dispensing steps and speeds.

**SD = Sequential Dispensing**

Up to 20 dispensing steps can be defined. Each dispensing step may have a different partial volume. The total volume may exceed the filling level of a pipette tip.

This means that new liquid for the pipette tip must be aspirated during the dispensing procedure. Only one aspirating and dispensing speed is defined for all dispensing steps.

**ADS = Automatic Dispensing**

With the Actuate key held down, all dispensings are executed automatically with the same volume and in a user-defined rhythm (0.1 – 10.0 seconds). Automatic dispensing may be interrupted by releasing the Actuate key. Apart from this, the procedure is identical to the DIS function.

**DIL = Diluting**

During the diluting process, a diluent, then an air bubble and finally a sample are aspirated into the pipette tip. The diluent volume and the sample volume are defined by the user. The air bubble is dependent on the sample volume and is always specified by the program. The entire contents of the pipette tip can be dispensed by selecting a pipetting option.

Depending on the pipette used, the dilution ratio is between approximately 1:2 and approximately 1:20.

**SDI = Serial Diluting**

For serial diluting, a defined volume of liquid is aspirated into the pipette tip. This liquid is dispensed and then mixed with a specific liquid volume by means of a programmable mixing process (volume, mixing cycles). The mixing procedure (MIX) is started by pressing the Actuate key separately.

**EDIT**

If **PROG** is in the display, the programming level can be opened by **holding down** the Program key. The Program key must be held down until the word **EDIT** appears in the display in front of **PROG 1 – 5**. Step-by-step programming is explained in the following sub-section.

If the programming of a program sequence is quit by pressing RESET, the entries for the program sequence are not stored.

The same program sequence – with, for example, different volumes or options – can be stored in several memory slots. It would therefore be possible for different pipetting sequences to be stored permanently in the program level.

Program sequences can be overwritten at any time under **EDIT** (Hold down the Program key).

During the programming process, the entry which is to be defined flashes in the display.

Selections are made using the Select rocker. Volumes are selected using the Volume rocker.





















Data is stored by pressing the Actuate key (ENTER function).

Options and speeds can be selected in the programming level by using the Select rocker or by using the Option or Speed key. Descriptions of how to use the Option and Speed keys can be found in Secs. 5.2 – 5.9. We recommend that you read these sections before you start programming. The following section on programming for pipetting contains only a description of operation using the rockers. Programming and execution of the other programs is contained in Part B of this manual, which is printed in English and Spanish.

## 5 Operation

### 5.10.1 Example for programming pipetting in the program level

#### Programming

		Press the key <b>briefly</b> until <b>PROG</b> appears in the display.
		Select the memory slot.
		<b>Hold down</b> the key until <b>EDIT</b> appears.
		 ENTER The input field flashes. Select <b>PIP</b> . Press the Actuate key.
 or 		 ENTER The input field flashes. Select the volume and store.
		 ENTER Select the aspirating and dispensing speed, and store. The direction arrow flashes.
		 ENTER The option is selected and stored. (The magnifying glass shows the standard mode.)
		Programming is now complete (here: standard mode; no option). EDIT disappears.

Programming can be ended prematurely and then stored by pressing the  key. EDIT disappears from the display.

If EDIT is ended with the  key before completion of programming for the memory slot, the changes are not transferred (emergency exit).

## 5 Operation

### Procedure



The sample is aspirated.

The remaining procedure depends on the pipetting option selected. Depending on the option, the procedure is identical to Sections 5.3 to 5.7.

When Prog. 1 – 5 are carried out, the Option and Speed keys as well as the Volume rocker are all disabled.

### 5.11 Device parameters

 **Device parameters may be changed only after thorough inspection and only by persons who are trained to do so!**

Device parameters are made up of the following:

**BE 1:** To switch on/off the acoustic signal for the keypad (short beep).

**BE 2:** To switch on/off the second acoustic signal for the end position of the dispensing piston, for warning and for confirmation (different beeps).

**CAL:** To alter the calibration data  $\mu\text{l}$ , axle section (b) and gradient (m).

**OPT:** Option for volume restriction

- When the 200  $\mu\text{l}$  tips are used with 300  $\mu\text{l}$  pipettes (limit: 200  $\mu\text{l}$ ).
- With "RP" and "DIS" when Filtertips are used.





Volume restriction ensures that no liquid comes into contact with the filter during "RP" and "DIS". It also guarantees that no liquid enters the pipette when 200  $\mu\text{l}$  tips are used.

**INI:** To initialize the original pipette data upon delivery.

The device parameters can all be found on one list. The Actuate key functions as an Enter key. After Enter has been pressed, the next line appears in the display.

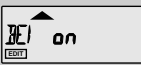
If a device parameter is quit using Reset, the setting which was made prior to change is valid.









Device parameters are called up as follows:

		<p>With the pipette switched on, press both keys <b>briefly at the same time</b>.</p>
		<p>To switch off/on acoustic signal for keypad.</p>
		<p>To switch on/off (on), second acoustic signal.</p>

## 5 Operation

5

Operation

		ENTER	To view calibration data (here: standard values).	
		ENTER	No CAL appears in the display. For changes, see Sec. 5.11.1.	
			ENTER	Smaller volume for Filtertips (here: changing from 10 µl to 8 µl for Filtertips). 300 µl pipette with 200 µl tip; restriction of 200 µl.
After changes have been made down to the smaller volume, a reminder to make the necessary changes for volume programming is also issued by means of the error message VOL.				
		ENTER	To exit the device parameters. For information on the INI procedure, see 5.11.2.	

### 5.11.1 Changing the calibration (CAL)

The Research pro is ideal for pipetting solutions with a density, viscosity, surface tension and vapor pressure which are not considerably different to that of water. It is not necessary to alter the calibration when such solutions are used. If, due to the physical properties of the solution, a pipetting volume is produced which is different to the volume displayed, an internal correction of the volume is possible.

The actual volume can be checked via weighing (see Sec. 2, "Technical data"):

$$\text{Actual volume} = \frac{\text{Mean value of weighings}}{\text{Density of liquid at weighing temperature}} \quad (1)$$

If the volume selected (display volume) is the same as the actual volume, no correction is necessary.

If there is a difference between the actual volume and the display volume, the following questions must be answered with "no" to enable calibration to take place:

- Does the pipette leak?
- Is there a temperature gradient between pipette and solution?
- Was a pipetting option chosen which was not optimal?
- Is the balance used to weigh the sample exposed to vibrations, drafts and similar influences?
- Is the value for "density at weighing temperature" incorrect?
- Were tips used which were not original eppendorf® pipette tips?

If the place where the pipette is used is at extremely high altitude, an adjustment must be made in line with the ambient air pressure. At 1,000 m above sea level, there is a volume error of approx. -0.4 %

## 5 Operation

The internal volume correction of the Research pro uses the following formula:

$$\text{Actual volume} = m \cdot \text{"Stroke movement"} + b \quad (2)$$

"m" is the definition of the gradient and "b" is the definition of the axis section of this equation (2).

When the device is delivered,  $m = 1,000$  and  $b = 0.0 \mu\text{l}$ . If this data is changed, the **CAL** symbol appears in the bottom right of the display. If the device is reset to the original values, the **CAL** symbol disappears.

If the **CAL** symbol appears in the display, the "stroke movement" is converted by the pipette using "m" and/or "b" which is selected by the user in order to ensure that the actual volume of the liquid used corresponds to the display volume.



**It is essential to inform all users of the changes made to the calibration data! We recommend labeling the pipette as follows (example only):**  
**Pipette calibrated only for use of "xy" with option "ZZZ".**

*Examples for volume correction:*

1. An actual volume of  $98 \mu\text{l}$  was calculated using formula (1).

*(Balance in mg; density in  $\text{mg}/\mu\text{l} = \text{g/ml}$ ).*

*The display volume is  $100 \mu\text{l}$ .*

*In this case, the following formula should be used:*

$$\frac{\text{Display volume } 100 \mu\text{l}}{\text{Actual volume } 98 \mu\text{l}} = 1.02$$

*The value 1.02 is entered under "m". This means that  $100 \mu\text{l}$  appears in the display, although the piston makes a stroke movement which is larger by a factor of 1.02, so that  $100 \mu\text{l}$  of this liquid can be aspirated.*

2. For corrections across a large volume range, the actual volumes for at least two greatly differing volumes should be determined. Via linear regression [calculator:  $y = mx + b$  (see formula 2)], the data for "m" and "b" is calculated by entering the actual volume (x) and the display volume (y).

The calibration data can be changed as follows:

- Call up the device parameters (see 5.11).
- Proceed using "ENTER" until "CAL 0.0  $\mu\text{L}$  b" appears in the display.
- Hold down the "Program" key until the number flashes.
- Set the desired number using the "Volume" or "Select" key.  
The **CAL** symbol appears when  $b \neq 0.0$ .
- Confirm the number selected by pressing "ENTER".
- The entry for "m" flashes. This can also be changed by pressing "Volume" or "Select".  
Entries are stored by pressing "ENTER".
- The ranges for "m" and "b" differ slightly according to the volume size of the pipette.



**Note: Following programming, the calculated data must then be checked via weighing and by using formula (1).**

**Hint:** In the case of mechanical pipettes, only axis section "b" can be corrected.

## 5 Operation

### 5.11.2 Information on initialization (INI)

If the Research pro is to be used at another workstation the (INI) function returns the pipette to the original factory calibration. If all volumes and programs defined by the user should no longer be used, the pipette can be initialized as per delivery package by means of INI.



**Following initialization, data previously programmed by the user can no longer be activated!**

Initialization is carried out as follows:

- Using "ENTER", access "INI" in the device parameters.
- Hold down the "Program" key.
- Initialization is completed when the device parameter "INI" disappears from the display.

## 6 Care, sterilization and maintenance

### 6.1 Care

The outside of the pipette can be wiped with a moist cloth. The use of water with wetting agent is also permitted.

**! Do not allow any liquid to enter the pipette!**

After that, **only the lower part** of the pipette should be rinsed with distilled water and dried. The pipette may be wiped clean with 60 % Isopropanol. The visible O-rings in the lower part of the multi-channel Research pro should be lubricated lightly with silicone grease and then wiped with a lint-free cloth. The procedure for replacing defective O-rings (when the pipette tips fit incorrectly) is described in Sec. 6.3.

If the pipette is severely contaminated or if very aggressive chemicals are dispensed, the lower half of the Research pro should be disassembled (see Sec. 6.2 for the single-channel model and Part B: "Ordering information" for the multi-channel model). The individual parts are rinsed in distilled water and then dried. The piston is then lightly lubricated using silicone grease.

**! After opening the pipette, please check that the piston is correctly positioned. A motor reset must also be executed. The motor reset is triggered by holding down the Reset key until **R** appears in the display.**

### 6.2 Sterilization

**Only the lower half** of the pipette can be steam-autoclaved (121 °C, 1 bar, 20 minutes). The autoclaved parts must be allowed to dry at room temperature. The entire lower part of the multi-channel model can be autoclaved as one unit. With the single-channel model, the individual parts of the lower part must be disassembled and autoclaved as separate pieces.

#### Lower part of multi-channel model

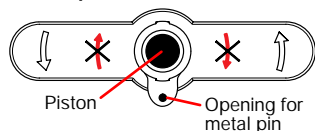

To loosen the lower part of the multi-channel pipette, rotate it in the arrow direction which is normally not permitted. Pull the lower part downwards slowly. The multi-channel piston, which is held in place magnetically, jerks sharply and then comes off.

When reassembling, please observe the following:

- Hold down the ejector for pipette tips (see Sec. 4.1).
- Position the lower part in such a way as to enable the metal pin on the ejector to enter the corresponding opening on the lower part.
- The magnetic coupling of the piston of the upper and lower part is indicated by a clicking noise.
- Do **not** hold down the ejector any longer and push the lower part firmly onto the metal pin of the ejector.
- Rotate the lower part in the permitted direction. When the lower part is rotated, a low "click" indicates that the safety coupling has connected and the lower part is firmly in place.
- After assembling the pipette, check that the ejector is working correctly.
- After assembling the pipette, actuate the motor reset by holding down the Reset key.
- Check that the dispensing function of the pipette is working correctly.

## 6 Care, sterilization and maintenance

6

Care, sterilization and maintenance

### Lower part of single-channel model

All volumes except 5,000  $\mu\text{l}$ :

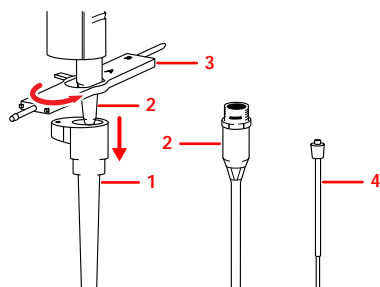

Hold down the ejector and pull off the ejector sleeve (1). Force may be required.

Unscrew the lower part (2) using the key (3). During disassembly, do not damage the piston!

Unscrew the piston (4). If necessary, first loosen the piston at the upper end using the flat-nose pliers. The piston is moved into its lowest position.

For 5,000  $\mu\text{l}$ :

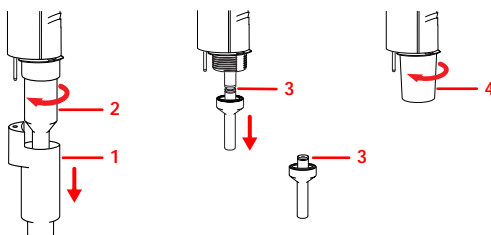

Hold down the ejector and pull off the ejector sleeve (1). Force may be required.

Unscrew the cylinder (2). The piston (3) is held in place magnetically. During disassembly, do not damage the piston!

Pull the piston (3) out of the upper part.

Using the disassembly tool in the accessories package (4), unscrew the cylinder bearing. During removal, the spigots of the disassembly tool are inserted into the openings on the cylinder bearing.

Assemble in reverse order. Engage the magnetic coupling of the 5,000  $\mu\text{l}$  piston as shown in the diagram. Check that the dispensing function of the pipette is working correctly.

### 6.3 Maintenance

Apart from general care and occasional discharging (when the battery symbol starts flashing) and recharging of the pipette, no special maintenance is necessary if the pipette is used correctly. The lower part of the pipette may be replaced completely. (How to disassemble the pipette is described in Sec. 6.2.) The process for replacing the seals in the lower part is described in Part B: "Ordering information/service parts". Maintenance on the Research pro may be carried out by the Service Department.





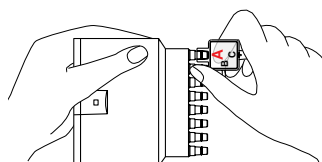







Contact Brinkmann Instruments at 800-645-3050 Ext. 404.

In the case of the lower parts of the eight- and twelve-channel models, it may be necessary to replace the O-rings (seals for pipette tips), which means that the lower part must be unscrewed. A tool for replacing the O-rings is contained in the accessories package:



- Press opening A of the tool over the nose cone. The sharp edge in the opening of the tool fits together with the O-ring.
- To cut the O-ring, press the tool heavily against the nose cone. The tool and the O-ring are then removed.
- Put the assembly aid (a shortened pipette tip) onto the nose cone and slide the new O-ring onto the nose cone.

## 7 Troubleshooting

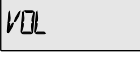
Display information	Cause	Solution
 Middle segment flashes.	The battery is run down.	Complete pipetting and recharge the battery (see Sec. 3.3).
 All segments flash.	The battery is severely run down.	Stop pipetting <b>immediately</b> and recharge the battery (see Sec. 3.3).
 Segments roll through the display.	The charging process is underway. All dispensing functions are blocked.	Charge the pipette until the battery symbol appears in the display without moving.
 Segments appear in the display without moving.	Charging process is finished.	Pipette is ready to use again.
 BATT Error !!	The pipette does not contain a battery!	Stop the recharging process <b>immediately</b> and insert a battery into the pipette!
 CON	Pipette was inserted into, or removed from, the charging adapter or the charging stand.	
 (Display is dark)	<ul style="list-style-type: none"> <li>- Pipette is in the Sleep mode.</li> <li>- The pipette does not contain a battery.</li> <li>- The battery is completely run down. (The battery also runs down during periods of non-use.)</li> </ul>	<ul style="list-style-type: none"> <li>- Press any key to switch on the pipette.</li> <li>- Insert the battery into the pipette.</li> <li>- Recharge the battery.</li> </ul>
 BRK	The piston movement was stopped by pressing the  key (emergency stop). A request to reset appears in the display.	Eject the pipette tip! When the  key is pressed a second time, the piston returns to its basic position.
 R 	The piston in the pipette must be moved to the basic position requested.	Press the  key. Caution! As the piston is moving, liquid may be dispensed!
 VOL	Appears when Actuate key is pressed. The volume cannot be aspirated because volume restriction is active.	Select the volume within a restricted range (Filtertips, 100 µl tip). Alternatively, cancel the volume restriction (Sec. 5.11).

Any other error message which appears in the display is only for error diagnosis by the Service Department.

If the error message does not disappear after a long Reset (Motor reset) or after the battery has been removed and reinserted (see Sec. 3.2), please contact the Service Department.

Additional information: When the battery is inserted, the program version and the data record appear in the display of the Research pro 4860.

## 7 Troubleshooting

7

Troubleshooting

Error	Cause	Solution
Pipette is dripping; the volume dispensed is incorrect.	<ul style="list-style-type: none"><li>- The tip may be loose.</li><li>- There may be foreign matter between the pipette and the tip.</li><li>- The piston, nose cone and cylinder may be damaged or contaminated.</li><li>- The lower part may be loose.</li><li>- For multi-channel model: The O-ring may be damaged.</li></ul>	<ul style="list-style-type: none"><li>- Attach the tip firmly. Make sure that an Eppendorf tip is used.</li><li>- Wipe the pipette. Ensure that the tip is protected from dust.</li><li>- Treat the lower half of the pipette as described in Sec. 6 and Part B "Ordering Information/ service parts".</li></ul>
Residual liquid is in the tip; dispensing is incomplete.	<ul style="list-style-type: none"><li>- See above.</li><li>- The dispensing speed may be too high.</li><li>- The incorrect pipetting option may have been selected.</li></ul>	<ul style="list-style-type: none"><li>- See above.</li><li>- The procedure for checking the function is described in Sec. 5, "Operation".</li></ul>
Motor stops during the dispensing procedure.	<ul style="list-style-type: none"><li>- The battery may be run down.</li><li>- The pipette may be heavily contaminated.</li></ul>	<ul style="list-style-type: none"><li>- Discard the dispensing as it is incorrect. Recharge the battery (Sec. 3.3) or treat the pipette as described in Sec. 6.</li></ul>

## Part B Contents / Parte B Índice

<b>Programs</b> .....	<b>87</b>
I. Introduction.....	87
II. SP = Sequential Pipetting.....	87
III. DIS = Dispensing as a program.....	89
IV. SD = Sequential Dispensing.....	90
V. ADS = Automatic Dispensing.....	93
VI. DIL = Diluting.....	95
VII. SDI = Serial Diluting.....	97
<b>Ordering information</b> .....	<b>100</b>
Research pro.....	100
Pipette tips.....	101
Additional accessories.....	102
Spare parts for single-channel pipettes.....	102
Change Service parts (single-channel).....	103
Spare parts for multi-channel model.....	104
Change volume unit 50 – 1200 µl.....	104
Important notes regarding ordering information.....	104
Change Service parts (multi-channel).....	105
<b>Programas</b> .....	<b>87</b>
I. Introducción.....	87
II. SP = Pipeteo secuencial.....	87
III. DIS = Dispensar como programa.....	89
IV. SD = Dispensación secuencial.....	90
V. ADS = Dispensación automática.....	93
VI. DIL = Diluir.....	95
VII. SDI = Diluir en serie.....	97
<b>Información para pedidos</b> .....	<b>100</b>
Research pro.....	100
Boquillas para pipeta.....	101
Otros accesorios.....	102
Piezas de repuesto para pipetas monocanal.....	102
Cambio piezas de servicio (monocanal).....	103
Piezas de repuesto para pipetas multicanal.....	104
Cambio unidad de volumen 50 – 1200 µl.....	104
Avisos importantes a las informaciones para pedido.....	104
Cambio piezas de servicio (multicanal).....	105

## Part B Programs / Parte B Programas

### I. Introduction / Introducción

This section contains a complete description of the additional six program sequences (see Sec. 5.10).

During programming (**EDIT** and **PROG** in display), the Speed and Option keys and the Volume rocker can also be used. This enables users to skip backwards and forwards during the program sequence.

When the programs are executed (only **PROG** is in the display), the Speed and Option keys and the Volume rocker are blocked.

If only parts of the program have to be changed, programming can be ended prematurely by pressing the Program key briefly.

If a memory slot is quit using Reset before programming has been completed, the changes which have been carried out for this memory slot are not carried out. EDIT disappears from the display.

Esta parte contiene una descripción completa de los otros 6 desarrollos de programa adicionales (ver cap. 5.10).

Durante la programación (**EDIT** y **PROG** en el visualizador), pueden utilizarse también las teclas Speed y Option y el selector de volumen. Esto permite a los usuarios saltar hacia delante y atrás durante la secuencia de programa.

Al ejecutar los programas (sólo **PROG** en el visualizador), las teclas Speed y Option y el selector de volumen están bloqueadas.

Si se deben cambiar solamente partes del programa, la programación puede finalizarse prematuramente, pulsando brevemente la tecla Programa.

Si se sale de un puesto de memoria con Reset antes de haber finalizado la programación, no se asumen los cambios realizados para este puesto de memoria. EDIT desaparece del visualizador.

### II. SP = Sequential Pipetting / Pipeteo secuencial

This program is suitable for sequences in which different volumes have to be pipetted consecutively on a regular basis. It is possible to program up to five volumes with option and speed.

Este programa es adecuado para secuencias en las que deben pipetearse de forma consecutiva diferentes volúmenes regularmente. Pueden programarse hasta 5 volúmenes con opción y velocidad.

#### Programming / Programación











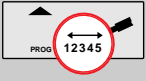











Program

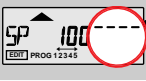

**PROG** in the display.

**PROG** en el visualizador.

## Part B Programs / Parte B Programas

<p>Select</p> 		<p>Select the memory slot. Selección del puesto de memoria.</p>
<p>Program</p> 		<p><b>Hold down</b> the key until <b>EDIT</b> appears. <b>Pulsar largo</b> la tecla hasta que aparezca <b>EDIT</b>.</p>
<p>Select</p> 		<p> ENTER Select <b>SP</b>. Seleccionar <b>SP</b>.</p>
<p>Select</p> 		<p> ENTER Selection of the pipetting sequences. After ENTER: Select "1" for the first sequence in the display. Selección de las secuencias de pipeteo. Tras ENTER: Seleccionar "1" para la primera secuencia en el visualizador.</p>
<p>or / o</p> <p>Volume</p> 	<p>Select</p>  	<p> ENTER Select the first volume, and store. Seleccionar el 1er. volumen y memorizar.</p>
<p>Select</p> 		<p> ENTER Select the speeds. Seleccionar velocidades.</p>
<p>Select</p> 		<p> ENTER Select the option. Seleccionar la opción.</p>
<p>Volume</p> 	 <p style="text-align: center;">⋮</p>	<p> ENTER Select the second volume. Seleccionar el 2º volumen.</p>
		<p>Programming is complete. EDIT disappears. La programación está completa. EDIT desaparece.</p>

## Part B Programs / Parte B Programas

### Procedure / Ejecución



Sample is aspirated. If **R** appears in the display, press



Se absorbe la muestra.  
Si aparece **R** en el visualizador, pulsar **R**.

How you now proceed depends on the pipetting option selected and on the number of sequences. The procedure carried out according to the option is identical to that described in Sec. 5.3 to Sec. 5.7.

El procedimiento siguiente depende de la opción de pipeteo seleccionada y del número de secuencias. La ejecución según la opción es idéntico al descrito en el cap. 5.3 al cap. 5.7.

### III. DIS =Dispensing as a program / DIS = Dispensar como programa

As a program, dispensing is protected from any accidental alterations. Please observe the volume restriction for Filtertips (see Sec. 5.11).

Como programa, la dispensación está protegida contra posibles cambios. Por favor, respete las limitaciones de volumen para Filtertips (ver cap. 5.11).

### Programming / Programación

Program



**PROG** in the display.

**PROG** en el visualizador.

Select



Select the memory slot.

Seleccionar el puesto de memoria.

Program



**Hold down** the key until **EDIT** appears.

**Pulsar largo** la tecla hasta que aparezca **EDIT**.









Select



ENTER

Select **DIS**.

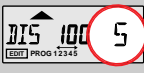
Seleccionar **DIS**.

<p>or / o</p> <p>Volume Select</p> 		 ENTER	<p>Select the dispensing volume. The max. number of dispensing steps appears in the right-hand side of the display.</p> <p>Seleccionar el volumen de dosificación. El número máx. de pasos de dosificación aparece a la derecha del visualizador.</p>
<p>Select</p> 		 ENTER	<p>Select the speeds. Seleccionar las velocidades.</p>
<p>Select</p> 		 ENTER	<p>Reduction of dispensing steps. Reducción de los pasos de dispensación.</p>

The dispensing procedure is described in Sec. 5.9.





El procedimiento de dispensación se describe en el cap. 5.9.

**IV. SD = Sequential Dispensing / Dispensación secuencial**

This program can be used when different volumes of a solution have to be dispensed consecutively. Up to 20 dispensing steps can be defined. If the sum of the dispensing steps is larger than the volume of the pipette tips, the procedure for normal dispensing is applicable when a liquid is aspirated repeatedly. Please observe the volume restriction for Filtertips (see Sec. 5.11).

Este programa puede usarse, cuando se tienen que dispensar de forma consecutiva diferentes volúmenes de una solución. Pueden definirse hasta 20 pasos de dispensación. Si la suma de los volúmenes de los pasos de dispensación es mayor que el volumen de las boquillas de pipeta, se aplica para la absorción repetida de un líquido el mismo procedimiento como para una dispensación normal. Por favor, observar los límites de volumen para Filtertips (ver cap. 5.11).

**Programming / Programación**

<p>Program</p> 		<p><b>PROG</b> in the display. <b>PROG</b> en el visualizador.</p>
<p>Select</p> 		<p>Select the memory slot. Seleccionar el puesto de memoria.</p>

## Part B Programs / Parte B Programas

Program



Hold down the key until *EDIT* appears.

Pulsar largo la tecla hasta que aparezca *EDIT*.

Select



ENTER

Select *SD*.

Seleccionar *SD*.

Select



ENTER

Determine the dispensing steps 1-20.

Determinar los pasos de dispensación 1-20.

or / o

Volume



Select



ENTER

Volume of the first dispensing step.

Volumen 1er. paso de dispensación.

or / o

Volume



Select



ENTER

Volume of the last dispensing step.

Volumen último paso de dispensación.

Select



ENTER

Select the speed for all dispensings.

Seleccionar la velocidad de todas las dispensaciones.



Programming is complete. *EDIT* disappears.

La programación está completa. *EDIT* desaparece.

Procedure / Ejecución

			<p>The necessary or largest possible amount of liquid is aspirated.  <i>If <b>R</b> appears in the display, press <b>R</b>.</i></p> <p>Absorción de la cantidad de líquido necesario o máximo posible.  <i>Si aparece <b>R</b> en el visualizador, pulsar <b>R</b>.</i></p>
			<p>The first step is dispensed.                  Dispensación del 1er. paso.</p>
			<p>The second step is dispensed.                  Dispensación del 2º paso.</p>
			<p>Blank step with special acoustic signal.                  Paso vacío con señal acústica especial.</p>
			<p>Blow-out is discarded.                  No dispensing step.</p> <p>Aspiration then occurs for the next dispensing steps or for repeating the first dispensing step.</p> <p>Descarga de la carrera excesiva.                  Sin paso dispensador.</p> <p>Absorción para los pasos siguientes de dispensación o para repetir el 1er. paso dispensador.</p>

## Part B Programs / Parte B Programas

### V. ADS = Automatic Dispensing / Dispensación automática

When microtiter plates are filled, a specific amount of liquid must often be dispensed in rapid succession. The automatic dispensing function allows a single volume to be dispensed repetitively with a predetermined time interval of between 0 and 10 seconds. This program is recommended for such an application.













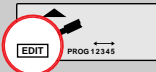

Please observe the volume restriction for Filtertips (see Sec. 5.11).

Al llenar placas de microtitraje, tiene que dispensarse una cantidad específica de líquido en sucesión rápida. La función de dispensación automática permite dispensar un volumen sencillo repetidamente con un intervalo predeterminado de tiempo entre 0 y 10 segundos.

Este programa se recomienda para esta aplicación.

Por favor, observar los límites de volumen para Filtertips (ver cap. 5.11).

### Programming / Programación

		<p><b>PROG</b> in the display. <b>PROG</b> en el visualizador.</p>
		<p>Select the memory slot. Seleccionar el puesto de memoria.</p>
		<p><b>Hold down</b> the key until <b>EDIT</b> appears. <b>Pulsar largo</b> la tecla hasta que aparezca <b>EDIT</b>.</p>
		<p>Select <b>ADS</b>. Seleccionar <b>ADS</b>.</p>
<p>or / o</p>  		<p>Select the dispensing volume, and store. Seleccionar el volumen de dispensación y memorizar.</p>
		<p>Select the aspirating and dispensing speed. Seleccionar la velocidad de absorción y de dosificación.</p>
		<p>Reduction of the dispensing steps. Reducción de los pasos de dispensación.</p>

			<p>Dispensing frequency. Delays between dispensings: 0.1 to 10 seconds.</p> <p>Frecuencia de dispensación. Retardo entre las dispensaciones: 0.1 a 10 segundos.</p>
			<p>Programming is complete.</p> <p>La programación está completa.</p>

Procedure / Ejecución

		<p>Aspiration of liquid. If <b>R</b> appears in the display, press <b>R</b>.</p>
		<p>Absorción de líquido. Si aparece <b>R</b> en el visualizador, pulsar <b>R</b>.</p>
		<p>Dispensing is carried out while the Actuate key held down. An acoustic signal is emitted after the dispensing step.</p> <p><b>Interruption:</b> Release the Actuate key.</p> <p>Dispensación manteniendo pulsada la tecla liberadora. Se emite una señal acústica después del paso de dispensación.</p> <p><b>Interruption:</b> Soltar la tecla liberadora.</p>
		<p>Dispensing is complete.</p> <p>La dispensación está completa.</p>
		<p>Blank step with special acoustic signal.</p> <p>Paso vacío con señal especial acústica.</p>

## Part B Programs / Parte B Programas



Blow-out is discarded.  
No dispensing step.

Descarga de la carrera  
excesiva.  
Sin paso dispensador.

### VI. DIL = Diluting / Diluir

In this case, the reagent – or diluent – and the sample are aspirated together into a pipette tip. A pipetting option can be used for dispensing both liquids.

Aquí se absorben el reactivo – o diluyente – y la muestra junto con una boquilla de pipeta. Puede usarse una opción de pipeteo para dispensar los dos líquidos.

### Programming / Programación

Program



**PROG** in the display.  
**PROG** en el visualizador.

Select



Select the memory slot.  
Seleccionar el puesto de memoria.

Program



**Hold down** the key until **EDIT** appears.  
**Pulsar largo** la tecla hasta que aparezca **EDIT**.

Select



ENTER

Select **DIL**.  
Seleccionar **DIL**.

or / o



ENTER

Sample volume:  
**Max. 50 % of the tip volume.**  
Volumen de muestra:  
**Máx. 50 % del volumen de la boquilla.**



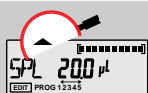







Select



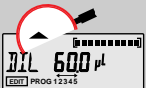

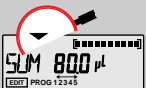









ENTER

Aspirating speed for sample.  
Velocidad de absorción de la muestra.

## Part B Programs / Parte B Programas

<p>or / o</p> <p>Select  Volume </p>		 ENTER	<p>Diluent volume: <b>Min. 47 % of the tip volume.</b></p> <p>Volumen de diluyente: <b>Min. 47 % del volumen de la boquilla.</b></p>
<p>Select </p>		 ENTER	<p>Aspirating speed of diluent. Velocidad de absorción del diluyente.</p>
<p>Select </p>		 ENTER	<p>Sum of sample + diluent. Selection of dispensing speed. Suma de muestra + diluyente. Selección de velocidad de dispensación.</p>
<p>Select </p>		 ENTER	<p>Pipetting options: BLO, RNS or Standard Opciones: BLO, RNS o estándar.</p>

### Procedure / Ejecución

		 ↑	<p>Diluent is aspirated. <i>If <b>R</b> appears in the display, press <b>R</b>.</i></p> <p>Absorción del diluyente. <i>Si aparece <b>R</b> en el visualizador, pulsar <b>R</b>.</i></p>
		 ↑	<p>Air bubble is aspirated. The volume is calculated by the program. Se ha absorbido una burbuja de aire. El programa calcula el volumen.</p>
		 ↑	<p>Sample is aspirated. Se absorbe la muestra.</p>
			<p>Sample – air – diluent are dispensed. Please observe the pipetting option! Dispensación de muestra – aire – diluyente. ¡Por favor, observar la opción de pipeteo!</p>

## Part B Programs / Parte B Programas

### Volume table Diluting (DIL)

Pipette	Sample ( $\mu$ l) * min. – max.	Air ( $\mu$ l) * min. – max.	Diluent ( $\mu$ l) * min. – max.
5000 $\mu$ l	100 – 2500	50 – 150	2350 – 4850
1200 $\mu$ l	50 – 600	12 – 36	480 – 1138
1000 $\mu$ l	50 – 500	10 – 30	470 – 940
300 $\mu$ l	20 – 150	3 – 9	141 – 277
100 $\mu$ l	5 – 50	1 – 3	47 – 94
10 $\mu$ l	0.5 – 5	0.1 – 0.3	4.7 – 9.4

\* The total volume of the pipette cannot be exceeded.  
The maximum sample volume can only be used with the minimum diluent volume, and vice-versa.

### Tabla de volúmenes Dilución (DIL)

Pipeta	Muestra ( $\mu$ l) * min. – max.	Aire ( $\mu$ l) * min. – max.	Diluyente ( $\mu$ l) * min. – max.
5000 $\mu$ l	100 – 2500	50 – 150	2350 – 4850
1200 $\mu$ l	50 – 600	12 – 36	480 – 1138
1000 $\mu$ l	50 – 500	10 – 30	470 – 940
300 $\mu$ l	20 – 150	3 – 9	141 – 277
100 $\mu$ l	5 – 50	1 – 3	47 – 94
10 $\mu$ l	0.5 – 5	0.1 – 0.3	4.7 – 9.4

\* No puede excederse el volumen total de la pipeta.  
El volumen máximo de muestra sólo puede usarse con el volumen mínimo de diluyente y viceversa.

### VII. SDI = Serial Dilution / Diluir en serie

In this program, pipetting is linked up to a specified number of mixing cycles. The program is used with a specimen liquid. The pipetting liquid (sample) is mixed together with the specimen liquid.

En este programa, el pipeteo va unido a un número específico de ciclos de mezcla. El programa se usa con un líquido ya preparado. El líquido a pipetear (muestra) se mezcla con el líquido ya preparado.

### Programming / Programación

Program



**PROG** in the display.  
**PROG** en el visualizador.

Select





















Select the memory slot.  
Seleccionar el puesto de memoria.

Program









**Hold down** the key until **EDIT** appears.  
**Pulsar largo** la tecla hasta que aparezca **EDIT**.

## Part B Programs / Parte B Programas

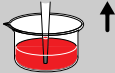
			Select <b>SDI</b> . Seleccionar <b>SDI</b> .
or / o  			Volume of sample. Volumen de la muestra.
			Aspirating and dispensing speed. Select a high speed! Velocidad de absorción y dispensación. ¡Seleccionar una velocidad alta!
			Stroke for mixing the specimen liquid and the sample. Carrera para mezclar el líquido ya preparado y la muestra.
			Mixing cycles (max. 20). Ciclos de mezcla (máx. 20).
			BLO pipetting option or standard operation. Opción de pipeteo BLO o modo estándar.

### Procedure / Ejecución

			Aspiration of sample. <i>If <b>R</b> appears in the display, press the <b>R</b> key.</i> Absorción de muestra. <i>Si aparece <b>R</b> en el visualizador, pulsar la tecla <b>R</b>.</i>
			Sample is dispensed. Dispensación de la muestra.

## Part B Programs / Parte B Programas

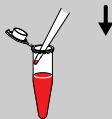

With BLO:  
Blow-out is executed.

Con BLO:  
Ejecución carrera excesiva.

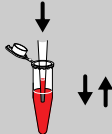

Start of the mixing cycles  
(here: 6). The counter shows  
the number of cycles  
remaining.

Inicio de los ciclos de mezcla  
(aquí: 6). El contador muestra el  
número de ciclos a realizar.

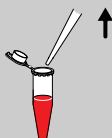
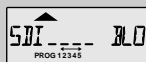

The pipette returns to the basic  
position when the key is  
pressed when the pipette is not  
immersed in the liquid.

Al pulsar la tecla, la pipeta  
retorna a la posición básica, si  
se encuentra fuera del líquido.

B

Programs / Programas

**Eppendorf Research pro, single-channel / monocanal**

incl. charging unit / con adaptador de carga *	0.5 – 10 µl	2246 130-3
incl. charging unit / con adaptador de carga *	5 – 100 µl	2246 131-1
incl. charging unit / con adaptador de carga *	20 – 300 µl	2246 132-0
incl. charging unit / con adaptador de carga *	50 – 1000 µl	2246 133-8
incl. charging unit / con adaptador de carga *	100 – 5000 µl	2246 134-6
without charging unit / sin adaptador de carga °	0.5 – 10 µl	2246 135-4
without charging unit / sin adaptador de carga °	5 – 100 µl	2246 136-2
without charging unit / sin adaptador de carga °	20 – 300 µl	2246 137-1
without charging unit / sin adaptador de carga °	50 – 1000 µl	2246 138-9
without charging unit / sin adaptador de carga °	100 – 5000 µl	2246 139-7

**Eppendorf Research pro, 8-channel / 8 canales**

incl. charging unit / con adaptador de carga *	0.5 – 10 µl	2246 140-1
incl. charging unit / con adaptador de carga *	5 – 100 µl	2246 141-9
incl. charging unit / con adaptador de carga *	20 – 300 µl	2246 142-7
incl. charging unit / con adaptador de carga *	50 – 1200 µl	2246 143-5
without charging unit / sin adaptador de carga °	0.5 – 10 µl	2246 144-3
without charging unit / sin adaptador de carga °	5 – 100 µl	2246 145-1
without charging unit / sin adaptador de carga °	20 – 300 µl	2246 146-0
without charging unit / sin adaptador de carga °	50 – 1200 µl	2246 147-8

**Eppendorf Research pro, 12-channel / 12 canales**

incl. charging unit / con adaptador de carga *	0.5 – 10 µl	2246 148-6
incl. charging unit / con adaptador de carga *	5 – 100 µl	2246 149-4
incl. charging unit / con adaptador de carga *	20 – 300 µl	2246 150-8
without charging unit / sin adaptador de carga °	0.5 – 10 µl	2246 151-6
without charging unit / sin adaptador de carga °	5 – 100 µl	2246 152-4
without charging unit / sin adaptador de carga °	20 – 300 µl	2246 153-2

- ° Pipettes sold without a charging unit must be charged in the optional charging stand.
- ° Pipetas vendidas sin adaptador de carga tienen que cargarse con el cargador opcional.

**Charging stand / Cargador**

for one pipette / para una pipeta *	2246 154-1
for four pipettes / para cuatro pipetas *	2246 155-9

- \* If the delivery address is not in the country in which the device shall be used:  
When placing your order, please specify the country in which the device is to be used and the voltage used in that country. Only then is it possible for us to deliver the power unit of the charging unit/stand with the necessary input voltage.
- \* Si la dirección de entrega no se encuentra en el país destino:  
Por favor, indicar en el pedido el país destino especificando la tensión allí usada. Sólo así podemos entregar la fuente de alimentación del adaptador de carga/cargador con la tensión de entrada necesaria.

**Pipette tips / Boquillas de pipeta**

The packing units stated represent the minimum order quantity.

Las cantidades indicadas representan la cantidad mínima de pedido.

**Bulk-packaged tips, in bags, 1,000 tips**

**Boquillas estándar, en bolsa, 1,000 unid.**

2.5 µl	2235 142-7
20 µl	2235 156-7
200 µl	2235 130-3
300 µl	2235 141-9
1000 µl	2235 090-1
1.25 ml	2226 570-9
5 ml (500 unid.)	2235 081-1

**Enviroset, 1 Envirobox autoclavable, plus 7 x 96 Envirotips in racks**

**Enviroset, 1 Envirobox autoclavable, más 7 x 96 Envirotips en racks**

2.5 µl	2249 049-4
20 µl	2249 050-8
200 µl	2249 055-9
300 µl	2249 057-5
1000 µl	2249 060-5
1.25 ml	2249 065-6

**Envirotips tip refills, 10 x 96= 960 tips**

**Envirotips en racks, 10 x 96= 960 unid.**

2.5 µl	2249 039-7
20 µl	2249 040-1
200 µl	2249 042-7
300 µl	2249 043-5
1000 µl	2249 044-3
1.25 ml	2249 045-1

**Enviroboxes, 1 Envirobox incl. 96 tips**

**Enviroboxes, 1 Envirobox plus 96 unid.**

2.5 µl	2249 079-6
20 µl	2249 080-0
200 µl	2249 085-1
300 µl	2249 087-7
1000 µl	2249 090-7
1.25 ml	2249 095-8
5 ml (28 tips / unid.)	2249 105-9

**Eppendorf Biopur pipette tips,**

colorless, sterile, pyrogen-free, DNA-free, RNase-free, ATP-free, in boxes, 5 x 96 = 480 tips

**Boquillas de pipeta Eppendorf Biopur,** incoloras, estériles, sin pirógeno, sin DNA, sin RNasa, sin ATP, en cajas, 5 x 96 = 480 unid.

20 µl	2249 000-1
200 µl	2249 002-8
300 µl	2249 003-6
1000 µl	2249 006-1

**Eppendorf Biopur pipette tips,**

individually wrapped, 1 set = 100 tips

**Boquillas de pipetas Eppendorf Biopur,** envase individual, 1 juego = 100 unid.

200 µl	2249 004-4
1000 µl	2249 008-7

**Filtertips, sterile,**

in boxes, 5 x 96 = 480 tips

**Filtertips, estériles,**

en cajas, 5 x 96 = 480 unid.

10 µl	2249 030-3
100 µl	2249 032-0
250 µl	2249 035-4
1000 µl	2249 034-6

## Part B Ordering information / Parte B Informaciones para pedido

### Additional accessories / Otros accesorios

Spare Ni-MH battery, 1,200 mAh / Repuesto batería NI-MH, 1,200 mAh	2246 701-8
Silicone grease / Grasa de silicona	2234 851-5
Reagent reservoir, autoclavable multi-channel reagent attachment, 1 set (10 tubs + 10 lids)	2226 580-6
Depósito para reactivo, toma-reactivo autoclavable multicanal, 1 set (10 tubos + 10 tapas)	
Lid of battery compartment / Tapa compartimento de pilas	2246 702-6
Wrench (not for 5,000 µl) / Llave (no para 5,000 µl)	2247 658-1
Disassembly aid 5,000 µl / Ayuda para desmontaje 5,000 µl	2247 660-2
Tools for multi-channel model / Herramientas para el modelo multicanal	
0.5 – 10 µl	2245 689-0
5 – 100 µl	2246 703-4
20 – 300 µl	2245 691-1
50 – 1200 µl	2246 704-2

### Spare parts for single-channel pipettes / Piezas de repuesto para pipetas monocanal

The disassembly procedure can be found in Sec. 6.2 / Para el desmontaje mirar el cap. 6.2

#### Ejection sleeve / Eyector

0.5 – 10 µl	2247 649-1
5 – 100 µl	2247 649-1
20 – 300 µl	2247 650-5
50 – 1000 µl	2247 652-1
100 – 5000 µl	2247 654-8

#### 1 – Lower part incl. seal

(See next page)

#### 1 – Parte inferior incl. junta

(Véase pág. siguiente)

0.5 – 10 µl	2247 665-3
5 – 100 µl	2247 669-6
20 – 300 µl	2246 710-7
50 – 1000 µl	2247 672-6
100 – 5000 µl	2246 711-5

(Cylinder and cylinder attachment for 100 – 5000 µl)

(Cilindro y toma del cilindro para 100 – 5000 µl)

#### Piston / Pistón

0.5 – 10 µl	2246 705-1
5 – 100 µl	2246 706-9
20 – 300 µl	2246 707-7
50 – 1000 µl	2246 708-5
100 – 5000 µl	2246 709-3

#### Sealing inside lower part

(Change service parts see next page)

#### Juntas en la pieza inferior

(Cambio piezas de servicio véase pág. siguiente)

#### 3 – Sealing set

#### 3 – juego de juntas

5 – 100 µl	2247 528-2
20 – 300 µl	2246 712-3
50 – 1000 µl	2247 646-7

#### 5 – Reducing tube (5 pieces, 1 wire punch)

#### 5 – Tubo de carga (5 piezas, 1 mandril expulsor)

5 – 100 µl	2247 655-6
20 – 300 µl	2247 656-4

Change Service parts (single-channel) / Cambio piezas de servicio (monocanal)

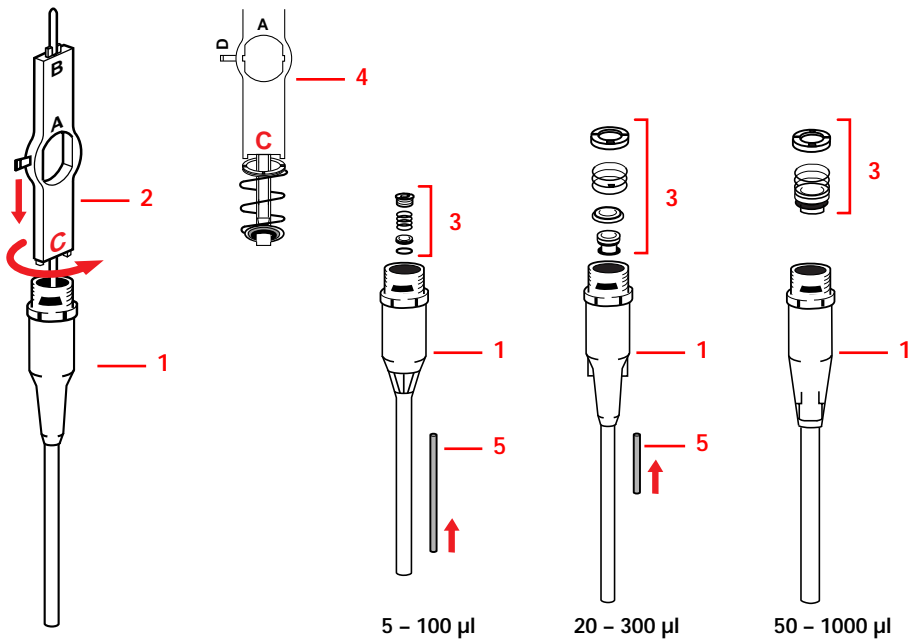

The seals in the lower part (1) are unscrewed from the lower part (which has been separated from the pipette; see Sec. 6.2) using the wrench (2). The lower parts for 0.5 – 10 µl and 100 – 5,000 µl do not contain any seals. With the 10 – 100 µl pipette, side B of the wrench (2) is used for screwing/unscrewing. Parts of the seal are then pulled out using side C (3). With the other pipettes, the seals are unscrewed using side C of the wrench or are tapped out after having been loosened. For mounting, the parts are placed onto the wrench (4). When screwing together, do not tighten too much. The filling tube (5) is delivered as a spare-parts pack together with a wire punch. After assembling, hold down the Reset key in order to trigger the motor reset and check that the device is functioning correctly.

Las juntas en la parte inferior (1) se desenrosca de la parte inferior (de la que se han separado de la pipeta; ver cap. 6.2) con la llave (2). Las partes inferiores para volúmenes 0.5 – 10 µl y 100 – 5,000 µl no llevan juntas. Con la pipeta de 10 – 100 µl, se usa el lado B de la llave (2) para enroscar/desenroscar. Después se sacan las partes de la junta con el lado C (3). Con otras pipetas, las juntas se desenrosca con el lado C de la llave o golpeando hacia afuera después de haber aflojado. Para el montaje, se colocan las partes en la llave (4). Al enroscar, no apretar demasiado. El tubo de carga (5) se entrega como paquete de pieza de repuesto equipado con un mandril expulsor. Después del montaje, pulsar largo la tecla Reset para provocar un reset de motor y controlar el funcionamiento correcto del dispositivo.

## Part B Ordering information / Parte B Informaciones para pedido

### Spare parts for multi-channel model / Piezas de repuesto para modelo multicanal

The disassembly procedure can be found in Section 6.3 / Para el procedimiento de desmontaje, leer el cap. 6.3

#### O-rings for nose cone (12 pieces)

incl. mounting aid (see Sec. 6.3)

#### Juntas tóricas para conos de trabajo

(12 piezas) con ayuda de montaje (ver cap. 6.3)

5 – 100 µl and / y	
20 – 300 µl	2245 635-1
50 – 1200 µl (8 pieces/8 piezas)	2246 713-1

#### Lower parts, cpl., 8-channel

Piezas inferiores, cpl., 8 canales

0.5 – 10 µl	2246 714-0
5 – 100 µl	2246 715-8
20 – 300 µl	2246 716-6
50 – 1200 µl	2246 717-4

#### Lower parts, cpl., 12-channel

Piezas inferiores, cpl., 12 canales

0.5 – 10 µl	2246 718-2
5 – 100 µl	2246 719-1
20 – 300 µl	2246 720-4

#### Piston seals for multi-channel model

Set of piston seals

(Change service parts see below and next page)

#### Juntas de pistón para multicanal

Set de juntas de pistón

(Cambio piezas de servicio ver abajo y pág. siguiente)

0.5 – 10 µl	2245 653-9
5 – 100 µl	2246 721-2
20 – 300 µl	2245 655-5

#### Volume unit / Unidad de volumen

50 – 1200 µl	2246 722-1
--------------	------------

#### Change volume unit 50 – 1200 µl

Loosen the screws in the housing lower part and lift the top half of the lower part. Press down the volume unit below which is to be exchanged, so that the upper part is lifted out of the groove.

#### Cambio unidad de volumen 50 – 1200 µl

Aflojar los tornillos de la semicarcasa inferior y levantar la mitad superior de ésta. Bascular la unidad de volumen a cambiar apretándola abajo, de modo que la parte superior salga fuera de la ranura.

### Important notes regarding ordering information

Only parts with order numbers are available. Please only use the accessories recommended by Eppendorf. Using disposables which we have not recommended can reduce the imprecision, inaccuracy and the life of the pipette. We do not honor any warranty or accept any responsibility for damage resulting from such action.

### Avisos importantes a las informaciones para pedido

Sólo se suministran piezas dotadas de número de pedido. Por favor, usar sólo los accesorios originales de Eppendorf. La imprecisión, la incorrección y la vida de la pipeta puede verse reducida con el uso de otras piezas que no estén recomendadas por nosotros. Declinamos todo tipo de garantía y de responsabilidad por los daños que resulten de ello.

## Part B Ordering information / Parte B Informaciones para pedido

### Change Service parts (multi-channel) / Cambio piezas de servicio (multicanal)

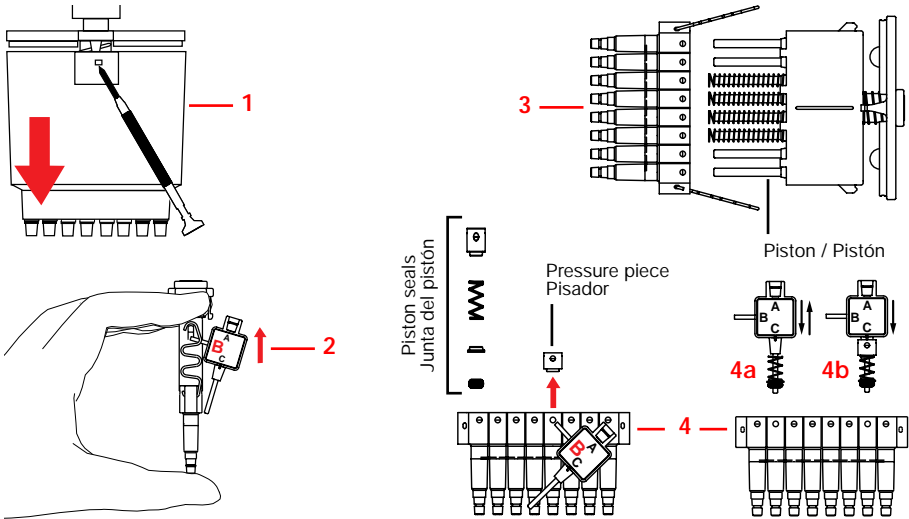

- Using the screwdriver, press in the catch and pull off the housing.
- Using the tool, lever off the metal clips from the safety hook. This part is under spring tension. Hold the part as shown in the diagram and loosen the metal clip on the other side.
- Pull off the tip holder (nose cones).  
**Caution!** The uneven loading of the spring in the pistons is deliberate. Note the spring loading and observe these notes during reassembly. Before cleaning the piston (with 60 % isopropanol), pull off the springs. Lightly lubricate the piston using silicone grease.
- Loosen the pressure piece using the punch (B) on the tool. The pressure piece is under spring tension. Hold the piece using your forefinger. Pull out the springs and the sealing ring using the tool (4a). Reassemble in reverse order. The parts are placed onto the tool (4b). Move piston in upper position. After assembling, hold down the Reset key in order to trigger the motor reset and check that the device is functioning correctly.

- Con el destornillador, apretar en la muesca y sacar el cuerpo.
- Con la herramienta, apalancar las pinzas metálicas del gancho de seguridad. Esta pieza se encuentra bajo tensión elástica. Sujetar la pieza como se muestra en el diagrama y aflojar la pinza metálica por el otro lado.
- Sacar el portaboquillas (conos de trabajo).  
**¡Precaución!** El equipamiento irregular de los resortes de los pistones es deliberado. Anotar el equipamiento de resortes y observar durante el montaje. Antes de limpiar el pistón (con 60 % isopropanol), sacar los resortes. Lubricar ligeramente el pistón con grasa de silicona.
- Aflojar el pisador con el mandril (B) en la herramienta. El pisador se encuentra bajo tensión elástica. Sujetar la pieza con los dedos índice. Sacar los resortes y el anillo obturador con la herramienta (4a). Remontaje en sentido inverso. Las piezas se colocan en la herramienta (4b). Llevar el pistón a la posición superior. Después del montaje, pulsar largo la tecla Reset para provocar un reset de motor y controlar el funcionamiento correcto del dispositivo.

# EG-Konformitätserklärung EC Conformity Declaration

Eppendorf - Netheler - Hinz GmbH • Barkhausenweg 1 • 22339 Hamburg • Germany

Das bezeichnete Gerät entspricht den einschlägigen grundlegenden Anforderungen der aufgeführten EG-Richtlinien und Normen. Bei einer nicht mit uns abgestimmten Änderung des Gerätes verliert diese Erklärung ihre Gültigkeit.

The device named below fulfills the relevant fundamental requirements of the EC directives and standards listed. In the case of unauthorized modifications to the device, this declaration becomes invalid.

Gerätebezeichnung, Device name:

**Eppendorf Research® pro 4860**

Gerätetyp, Device type:

**elektrische Pipette / electronic pipette**

Einschlägige EG-Richtlinien/Normen, Relevant EC directives/standards:

**89/336/EWG, EN 50082-1, EN 55011, EN 61000-3-2, EN 61000-3-3**

**73/23/EWG, EN 61010-1**

02.09.1999

Hamburg, Date:

Geschäftsführung, Managing Director:

Projektleitung, Project Management:

0015 033.509-00

**eppendorf**



4860 900.993-00

**Tolerance Check**  
**Protocole de mesure**  
**Protocollo de medición**

□

□

□

□

**eppendorf**

*In touch with life*

Brinkmann Instruments, Inc. · One Cantiague Road, P.O. Box 1019 · Westbury, New York 11590-0207 (USA)

Phone: 800-645-3050 · Fax: 516-334-7506 · e-mail: info@brinkmann.com

Brinkmann Instruments Ltd. · 6670 Campobello Road · Mississauga, Ont. L5N 2L8 (Canada)

Phone: 800-263-8715 · Fax: 905-826-5424 · e-mail: brinkmann@on.aibn.com

eppendorf is a registered trademark.  
B4860 900.020-00/1299 · Printed in Germany · Printed on chlorine-free bleached paper