



Surgical Instruments
www.frimed.com







Tobias Schwoy

Managing Director
Frimed Medizintechnik GmbH

Sehr geehrter Geschäftsfreund, sehr geehrter Kunde,

ich freue mich sehr Ihnen unseren neuen komplett überarbeiteten Hauptkatalog chirurgischer Instrumente der verschiedensten Disziplinen vorstellen zu dürfen. Bei der Auswahl der Produkte in den verschiedenen Disziplinen, sind wir mit der größtmöglichen Sorgfalt bezüglich der Aktualität der Instrumente vorgegangen. Es besteht in allen gängigen chirurgischen Disziplinen die Möglichkeit, sich die Instrumente selbst zusammen zu stellen, oder aber, Sie können sich auch von uns, auf Anforderung, Instrumentensätze zusammenstellen lassen, die uns für Ihre jeweils spezifischen Aufgaben als geeignet erscheinen. Ich für meinen Teil, wünsche Ihnen auf jeden Fall, viel Erfolg in Ihrer täglichen Arbeit und würde mich freuen, wenn Sie uns und unserem Instrumentarium auch in Zukunft weiterhin die Treue halten würden.

Dear business associate and/or customer,

I am very pleased to present you our new, completely revised main catalogue of surgical instruments for the various disciplines. When selecting the products for the various disciplines, we took extreme care to ensure that the instruments are up to date. In all common surgical procedures, it is possible to assemble the instrument sets yourself at your request, or to have us assemble sets of instruments that we judge to be suitable for your specific tasks. For my part, I would like to wish you every success in your daily work and would very much appreciate your continued loyalty to us and our range of instruments in the future.

Estimado corresponsal, estimado cliente,

me alegra poder presentarles nuestro nuevo catálogo general de instrumentos quirúrgicos para las diferentes especialidades, completamente revisado. Para la selección de los productos en las diferentes especialidades hemos procedido con el máximo esmero posible en relación a la actualidad de los instrumentos. En todas las especialidades quirúrgicas existe la posibilidad de agrupar por sí mismo los instrumentos, o bien Ud. también puede solicitar que nosotros agrupemos juegos de instrumentos apropiados para sus tareas específicas. Por mi parte les deseo mucho éxito en su trabajo diario y me alegraría si en el futuro continuáran manteniendo la confianza en nosotros y en nuestros instrumentos.

Gentile socio d'affari, Gentile cliente,

sono lieto di poterle presentare il nostro nuovo catalogo generale di Strumenti chirurgici delle più diverse discipline, completamente rielaborato. Per la scelta dei prodotti nelle diverse discipline abbiamo proceduto con massima accuratezza in riguardo all'attualità degli strumenti. È possibile assortire in modo individuale gli strumenti in tutte le discipline chirurgiche correnti, oppure, su richiesta, Le possiamo anche proporre un assortimento di set di strumenti, che ci sembrano appropriati di volta in volta ai Suoi compiti specifici. Da parte mia Le auguro, in ogni caso, di poter svolgere il Suo lavoro quotidiano con successo e sarei lieta di poterla ancora annoverare tra i nostri clienti, assicurando così, a noi e ai nostri strumenti, il Suo apprezzamento anche in futuro.

Tobias Schwoy
Managing Director



Die Fertigung unserer Produkte ist eine Symbiose aus lang-jähriger handwerklicher Tradition und modernsten Fertigungsabläufen mittels CNC gesteuerter Fertigungszentren, welches einen hochwertigen Funktions- und Qualitätsstandard unserer Produkte sicher stellt.

Our product manufacturing is a symbiosis of many years of tradition in craftsmanship combined with the most modern production processes using CNC-controlled manufacturing centres, which ensures the highest standard in terms of both functioning and quality for our products.

La fabricación de nuestros productos es la simbiosis de una larga tradición artesanal y modernos procesos de fabricación mediante CNC, lo que asegura un elevado estándar de funcionamiento y calidad de nuestros productos.

La lavorazione dei nostri prodotti è una simbiosi tra la tradizione artigiana pluriennale e i più moderni processi di produzione attraverso centri di lavoro a CNC, che assicurano ai nostri prodotti un alto standard di qualità e di funzionamento.



Bereits bei der Vorauswahl und Materialprüfung der verwendeten Werkstoffe, hauptsächlich korrosionsbeständige Chromstähle, halten wir uns an die uns selbst auferlegten strengen Qualitätsmaßstäbe die sich kontinuierlich über den ganzen Fertigungsprozess hindurch fortsetzen, wodurch wir eine sehr hohe und immer wiederkehrende Produkt- und Modelltreue erzielen.

We adhere to strict quality standards that we impose on ourselves as early as during the preselection and testing of the materials of construction used, which are mainly corrosion-resistant chrome steels. These standards apply throughout the entire manufacturing process, thus ensuring a very high and very repeatable degree of product and model consistency.

Ya en la preselección y control de los materiales utilizados, esencialmente aceros al cromo resistentes a la corrosión, cumplimos nuestras exigentes normas de calidad que se propagan de forma continua en todo el proceso de fabricación, alcanzando siempre un producto de alta calidad y exacto al modelo.

Già nella selezione anticipata e nel controllo dei materiali utilizzati, generalmente acciai al cromo resistenti alla corrosione, ci atteniamo alle severe misure di qualità da noi stessi fissate, che vengono continuamente applicate a tutto il processo di lavorazione, pur ottenendo comunque un'alta e sempre ricorrente fedeltà al modello del prodotto.

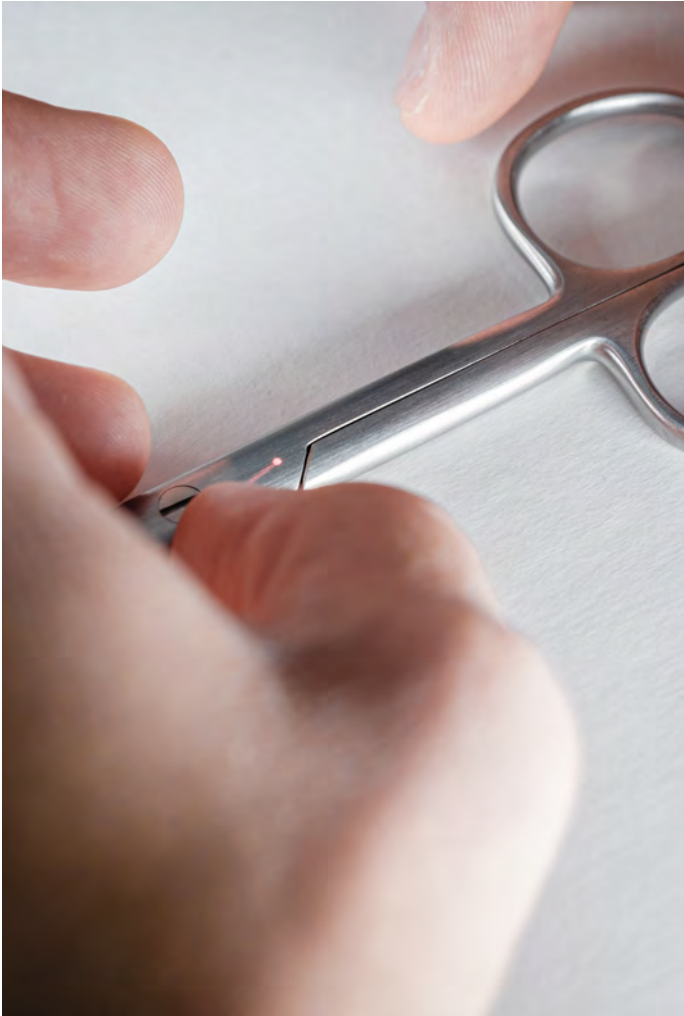

Jeder Einzelne unserer hoch qualifizierten und hoch motivierten Mitarbeiter und Mitarbeiterinnen engagiert sich tagtäglich auf das Neue und sieht in der Erfüllung der Bedürfnisse und Wünsche unserer Kunden seine oberste Pflicht.

All our highly qualifield and highly motivated employees do their utmost every single day and dedicate themselves to fulfilling the needs and wishes of our customers.

Cada uno de nuestros colaboradores, altamente calificado y motivado, se compromete a diario de nuevo y considera su obligación en la satisfacción de las necesidades y deseos de nuestros clientes.

Ogni nostro singolo collaboratore, altamente qualificato e motivato, è disponibile ogni giorno a nuove sfide e s'impone come dovere assoluto la soddisfazione dei bisogni e delle richieste dei clienti.



Im Mittelpunkt unserer Firmenphilosophie stehen der Kunde und der Anwender mit ihrem berechtigten Interesse an der Qualität unserer Instrumente. Ein perfekt auf alle Unternehmensbereiche abgestimmtes Qualitäts Management System regelt die kundenorientierten Abläufe, beginnend bei der Produktion bis hin zu der Rückverfolgbarkeit aller Produkt- und Kundenrelevanten Daten. Alle von uns gelieferten Instrumente sind mit dem CE Kennzeichen versehen.

The focus of our company philosophy is the customer and user with their justified interest in the quality of our instruments. A Quality Management System that is ideally adapted for all company areas controls the customer oriented processes, starting with production and continuing right through to the after-sales service.

Como centro de la filosofía de la empresa se encuentra el cliente y los usuarios, con su merecido interés en la calidad de nuestros instrumentos. Un perfecto sistema de control de calidad en todas las áreas de la empresa regula los ciclos orientados al cliente, comenzando en la producción hasta la trazabilidad de todos los datos relevantes sobre los productos y clientes. Todos los instrumentos fabricados por nosotros poseen la marca CE.

Al centro della filosofia della nostra ditta si trovano il cliente e l'utente con il Loro giustificato interesse alla qualità dei nostri strumenti. Un sistema di gestione in perfetta armonia con tutti i settori aziendali regola i processi orientati al cliente, a cominciare dalla produzione fino a la tracciabilità di tutti i dati pertinenti sui prodotti e clienti. Tutti gli strumenti da noi forniti sono provvisti con il marchio CE.



Certificate

mdc medical device certification GmbH
certifies that

FRIMED
MEDIZINTECHNIK GMBH

Frimed Medizintechnik GmbH
Junkersstraße 1
78532 Tuttlingen
Germany

for the scope
production and distribution of surgical instruments
has introduced and applies a
Quality Management System

The mdc audit has proven that this quality management system
meets all requirements of the following standard

EN ISO 13485

Medical devices – Quality management systems –
Requirements for regulatory purposes

EN ISO 13485:2016 + A1:2017 + A1:2021 + A1:2021-10:2018

Valid from: 2022-12-22
Valid until: 2024-11-19
Registration no.: D192400001
Report no.: P22-01942-248234
Stuttgart: 2022-12-22

Head of Certification Body

mdc medical device certification GmbH
Ergebnisbericht 8
D-70791 Stuttgart, Germany
Phone: +49 (0) 71 23397-6
Fax: +49 (0) 71 23397-10
Internet: <http://www.mdc-up.de>

DAKS
DIN EN ISO 9001
CERTIFIED

EU Quality Management System Certificate

mdc medical device certification GmbH
Königsstr. 6, 70379 Stuttgart, Germany
Notified body (identification number 0453)

hereby certifies that the company

Frimed Medizintechnik GmbH
Junkersstraße 1
78532 Tuttlingen
Germany

has implemented and applies a quality management system in accordance with Annex IX, Chapter 1 of Regulation (EU) 2017/745 for conformity assessment of the devices listed on the following pages.

An audit by mdc has proven that this quality management system fulfils the following requirements:
Annex IX - Chapter 1 (Quality Management System)
of Regulation (EU) 2017/745 of the European Parliament and of the Council of 5 April 2017 on medical devices

Surveillance is carried out in accordance with Annex IX, Section 3 of Regulation (EU) 2017/745.

This certificate consists of 6 pages. Details of the devices affected by this certificate as well as further information and conditions are included on the following pages.

Valid from: 2022-02-21 Registration No.: 0192400006
Valid until: 2022-03-08 Evaluation Report No.: 210209

Stuttgart: 2022-02-21

Head of Notified Body

T.M.C.
TÜV
Technische Mess- und
Prüfungsgesellschaft
Stuttgart





Frimed befindet sich zwischen Stuttgart und Zürich in unmittelbarer Nähe zu der Autobahn A 81 Abfahrt Tuningen, inmitten von Tuttlingen dem weithin bekannten Weltzentrum der Medizintechnik. Besucher sind jederzeit recht herzlich willkommen.

Frimed is located between Stuttgart and Zurich right beside the exit 'Tuttlingen' on the A81 motorway, in the centre of Tuttlingen, the well-known world centre for medical technology. Visitors always are very welcome.

La empresa Frimed se encuentra entre Stuttgart y Zurich, en la cercanía de la autopista A81 Salida - Tuningen, en el centro de Tuttlingen, el conocido centro mundial de la técnica médica. Los visitantes son siempre bienvenidos.

Frimed si trova fra Stoccarda e Zurigo nelle immediate vicinanze dell'autostrada A 81 uscita Tuningen, nel bel mezzo di Tuttlingen, centro conosciuto a livello mondiale per la tecnica medica. I visitatori sono sempre benvenuti.

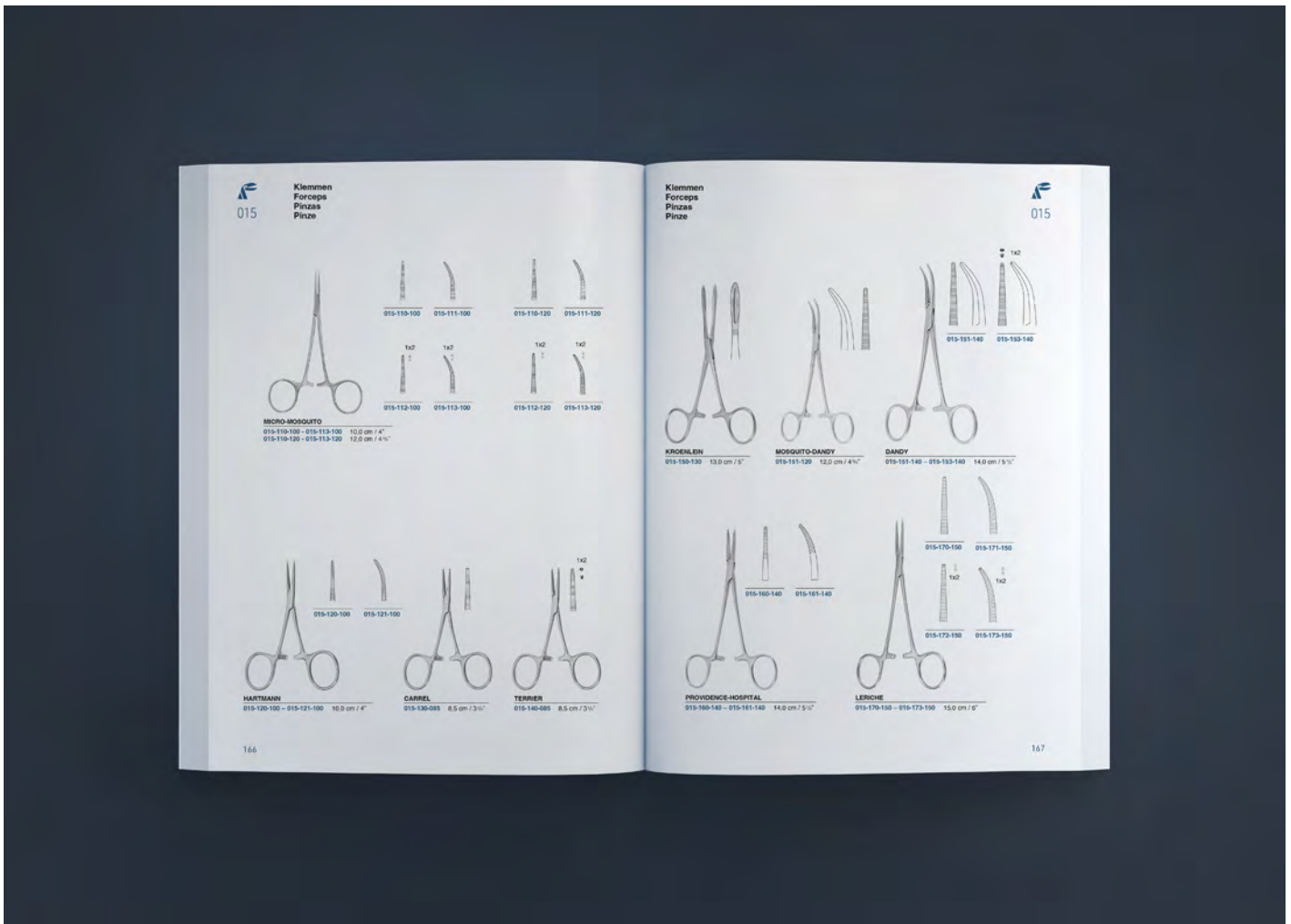

Der Aufbau des Frimed Hauptkataloges erfolgte in numerisch aufsteigender Reihenfolge. Damit ist jede Artikelnummer jederzeit sofort auffindbar. Die Artikelnummer gibt Auskunft über die Artikelgruppe/Details des Artikels wie Größe und/oder Figur des Instrumentes.

The Frimed main catalogue is structured in numerical order, starting with the lowest numbers. This means that every article number can be quickly located at any time. The article number provides information about the article group and details concerning the article such as size and/or the form of the instrument.

El catálogo general de Frimed está estructurado numéricamente de forma ascendente. De esta forma, cada número de artículo se encuentra rápido y en cualquier momento. El número de artículo informa sobre el grupo/detalles del mismo, como por ejemplo tamaño y/o figura del instrumento

La struttura del catalogo generale Frimed è in successione numerica ascendente. In questo modo ogni numero di articolo è rintracciabile subito in ogni momento. Il numero di articolo offre informazioni sul gruppo di articoli/dettagli riguardanti l'articolo così come la grandezza e/o l'immagine dello strumento



012-722-210

Artikelgruppe / Disziplin
Product Group / Discipline
Grupo de artículo / Disciplina
Gruppo di articolo / Disciplina

Laufende Nummer innerhalb der Artikelgruppe
Current catalogue number within the group
Número ordinal dentro del grupo
Numero progressivo all'interno del gruppo

Größe / Figur des Instruments
Size / Shape of the instrument
Tamaño / Forma del instrumento
Dimensione / Forma dello strumento

012

Chirurgische Scheren mit Hartmetallschneiden
Surgical Scissors with tungsten carbide edges
Tijeras para cirugía con filos de carburo tungsteno
Forbici per chirurgia con lame in carburo di tungsteno

Brand	Article Number	Dimensions
LEXER	012-722-160	16,0 cm / 6 1/4"
	012-722-210	21,0 cm / 8 1/4"
METZENBAUM	012-730-115 - 012-731-115	11,5 cm / 4 1/2"
	012-730-145 - 012-731-145	14,5 cm / 5 1/2"

56

Artikel-Nummer
Item number
Nº del artículo
Codice articolo

Autor
Author
Autor
Autore

Arbeitsende
Detail des Instruments

Working end /
Detail of the instrument

Extremo funcional
Detalle del instrumento

Extremidad funcional
Dettaglio dello strumento

Maße
Dimensions
Dimensiones
Dimensioni



Inhalt / Content / Tabla / Indice

010	Skalpelle und Messer	1-12
	Scalpes and Knives	1-12
	Bisturies y Cuchillos	1-12
	Bisturi e Coltelli	1-12
011	Mikro-Scheren	13-18
	Micro Scissors	13-18
	Micro Tijeras	13-18
	Micro Forbici	13-18
012	Scheren	19-74
	Scissors	19-74
	Tijeras	19-74
	Forbici	19-74
013	Pinzetten - anatomische, chirurgische, Mikro	75-98
	Forceps - anatomics, surgicals, Micro	75-98
	Pinzas - anatómicas, quirúrgicas, Micro	75-98
	Pinze - anatomiche, chirurgici, Micro	75-98
015	Arterienklemmen, Korn- und Tupferzangen	99-148
	Artery Forceps, Dressing and Sponge Forceps	99-148
	Pinzas hemostáticas, Pinzas para torundo y vendajes	99-148
	Pinze emostatiche, Pinze per medicatura e tamponi	99-148
016	Wundhaken, Wundspreizer, Bauchdeckenhalter	149-218
	Retractors, Self-retaining Retractors, Abdominal Retractors	149-218
	Separadores, Separadores autoestáticos, Separadores abdominales	149-218
	Divaricatori, Divaricatori autostatici, Divaricatori addominali	149-218
017	Sonden, Aspiration	219-240
	Probes, Aspiration	219-240
	Sondas, Aspiración	219-240
	Sonde, Aspirazione	219-240
018	Diagnostik, Narkose	241-250
	Diagnostics, Anaesthesia	241-250
	Diagnóstico, Anestesia	241-250
	Diagnóstica, Anestesia	241-250
019	Naht	215-304
	Suture	215-304
	Sutura	215-304
	Sutura	215-304



Inhalt / Content / Tabla / Indice

020	Verband, Gips	305-314
	Dressing, Plaster	305-314
	Vendajes, Escayolas	305-314
	Bendaggi, Gessatura	305-314
021	Knochenchirurgie	315-340
	Bone Surgery	315-340
	Cirugía ósea	315-340
	Chirurgia ossea	315-340
024	Knochenchirurgie	341-432
	Bone Surgery	341-432
	Cirugía ósea	341-432
	Chirurgia ossea	341-432
025	Thorax, Cardiovascular-Chirurgie	433-502
	Thorax, Cardiovascular Surgery	433-502
	Torácio, Cirugía cardiovascular	433-502
	Torace, Chirurgia cardiovascolare	433-502
026	Neurochirurgie, Laminektomie	503-532
	Neurosurgery, Laminectomy	503-532
	Neurocirugía, Laminectomía	503-532
	Neurochirurgia, Laminectomia	503-532
027	Magen, Darm, Urologie	563-604
	Stomach, Intestines, Urology	563-604
	Estómago, Intestinos, Urología	563-604
	Stomaco, Intestini, Urologia	563-604
030	Gynäkologie, Geburtshilfe	605-660
	Gynecology, Obstetrics	605-660
	Ginecología, Ostetricia	605-660
	Ginecologia, Ostetricia	605-660
032	Ophthalmologie	661-684
	Ophthalmology	661-684
	Oftalmología	661-684
	Ophtalmologia	661-684
034	Otologie	685-716
	Otology	685-716
	Otología	685-716
	Otologia	685-716



Inhalt / Content / Tabla / Indice

035	Rhinologie.....	717-762
	Rhinology.....	717-762
	Rinología.....	717-762
	Rinologia.....	717-762
037	Mund-, Kiefer- und Gesichtschirurgie.....	763-802
	Oral Maxillo-Facial Surgery.....	763-802
	Cirugía oral y maxilofacial.....	763-802
	Chirurgia maxillo-facciale.....	763-802
046	Dermatologie.....	803-810
	Dermatology.....	803-810
	Dermatología.....	803-810
	Dermatologia.....	803-810
085	Sterilisation, Hygiene, Aufbewahrung.....	811-838
	Sterilisation, Hygiene, Storage.....	811-838
	Esterilización, Higiene, Almacenaje.....	811-838
	Sterilizzazione, Magazzinaggio.....	811-838



010

Skalpelle und Messer
Scalpes and Knives
Bisturies y Cuchillos
Bisturi e Coltelli



010

Anatomische Skalpelle
Dissecting knives
Bisturios para disección
Bisturi per dissezione

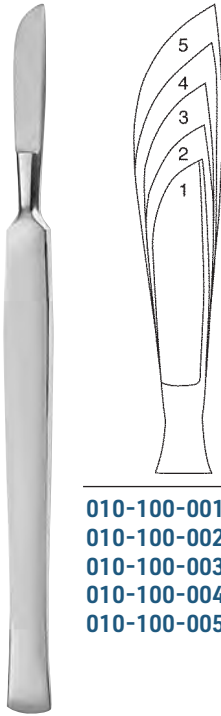

- 010-100-001** Fig. 1
- 010-100-002** Fig. 2
- 010-100-003** Fig. 3
- 010-100-004** Fig. 4
- 010-100-005** Fig. 5

mit Metallheft
with metal handle
con mango metálico
con manico di metallo

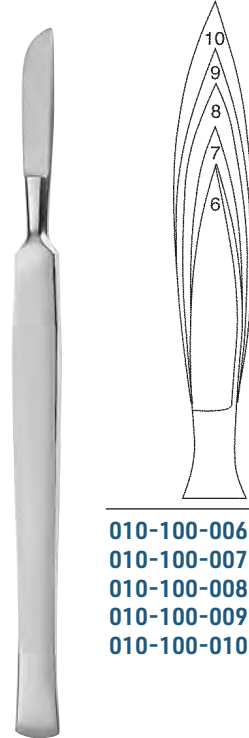

- 010-100-006** Fig. 6
- 010-100-007** Fig. 7
- 010-100-008** Fig. 8
- 010-100-009** Fig. 9
- 010-100-010** Fig. 10

010-100-001 - 010-100-005 15,0 cm / 6"

010-100-006 - 010-100-010 15,0 cm / 6"

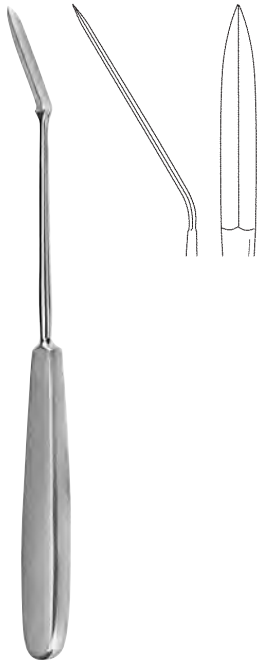

AYRE

010-110-235 23,5 cm / 9 1/4"

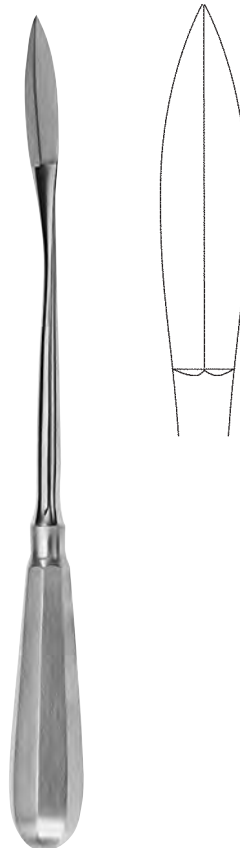

SEGOND

010-120-270 27,0 cm / 10 1/2"

Seziermesser, Knorpelmesser,
Autopsy knives, Cartilage knives
Cuchillos para autopsia, cuchillos para cartilago
Coltelli per autopsia, coltelli per cartilagini



010

mit Holzheft
with wooden handle
con mango de madera
con manico di legno

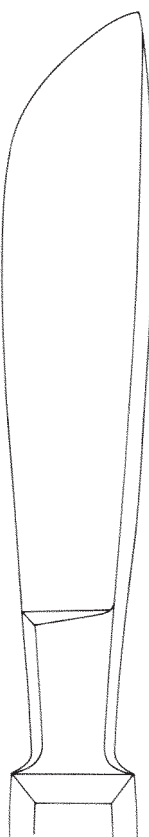

VIRCHOW
010-130-210

21,0 cm / 8 1/4"

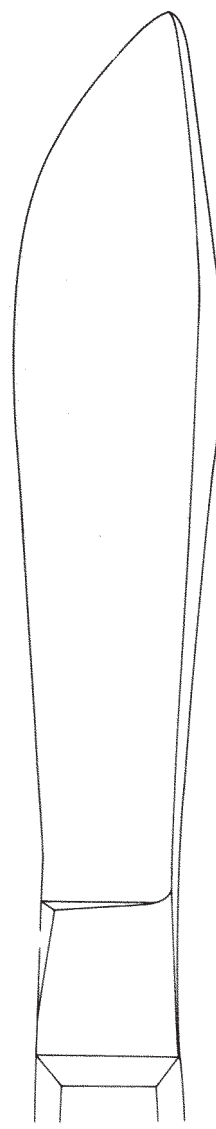

010-140-255

25,5 cm / 10"



010

Organmesser, Messer
Post mortem knife, Knife
Cuchillos para órganos
Coltelli

mit Metallheft
with metal handle
con mango metálico
con manico di metallo

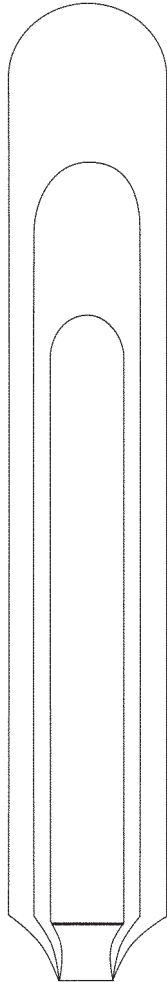

VIRCHOW

010-150-160	16,0 cm, 6 ¹ / ₄ "
010-150-200	20,0 cm, 8"
010-150-240	24,0 cm, 9 ¹ / ₂ "

mit Holzheft
with wooden handle
con mango de madera
con manico di legno



WALB

010-160-110	11,0 cm, 4 ¹ / ₃ "
010-160-140	14,0 cm, 5 ¹ / ₂ "
010-160-170	17,0 cm, 6 ⁴ / ₃ "



massiv
 solid
 macizo
 pieno

STANDARD Nr. 3

010-200-003 12,0 cm / 4³/₄"



massiv
 solid
 macizo
 pieno

mit cm - Graduierung
 with cm - graduation
 graduado en cm
 graduato in cm

Nr. 3

010-202-003 12,0 cm / 4³/₄"



massiv
 solid
 macizo
 pieno

STANDARD Nr. 4

010-210-004 12,0 cm / 4³/₄"



massiv
 solid
 macizo
 pieno

gerade
 straight
 recto
 retto

Nr. 3L

010-204-003 21,5 cm / 8¹/₂"

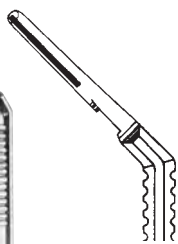

massiv
 solid
 macizo
 pieno

abgewinkelt
 angled
 acodado
 angolare

Nr. 3L

010-205-003 21,0 cm / 8¹/₄"



Nr. 3

010-206-003 21,5 cm / 8¹/₂"



Nr. 3

010-207-003 21,5 cm / 8¹/₂"



010

Skalpellgriffe
Scalpel Handles
Mangos de Bisturi
Manici per bisturi



massiv
solid
macizo
pieno

Doppelgriff
Double Hand
Mango doble
Manico doppio

Nr. 3 + 4
010-212-034 16,0 cm / 6 1/4"



massiv
solid
macizo
pieno

gerade
straight
recto
retto

Nr. 4L
010-214-004 21,5 cm / 8 1/2"



massiv
solid
macizo
pieno

abgewinkelt
angled
acodado
angolare

Nr. 4L
010-215-004 21,0 cm / 8 1/4"



Nr. 4
010-216-004 22 cm / 8 3/4"



massiv
solid
macizo
pieno

Nr. 7
010-220-007 16 cm / 6 1/4"



massiv
solid
macizo
pieno

Nr. 7K
010-222-017 12,5 cm / 5"



hohl, rund
hollow, round
hueco, redondo
vuoto, rotondo

010-230-003 15,5 cm / 6"

steril
 serile
 estériles
 sterile



Fig. 10
010-260-010



Fig. 11
010-260-011



Fig. 12
010-260-012



Fig. 13
010-260-013



Fig. 14
010-260-014



Fig. 15
010-260-015

passend für Skalpellgriffe / for scalpel handles / para mangos / per i manici
 010-210-014, 010-220-007, 010-220-17, 010-230-000

steril
 serile
 estériles
 sterile



Fig. 16
010-260-016



Fig. 17
010-260-017



Fig. 12d
010-261-012



Fig. 15c
010-261-015

* doppelschneidig
 double cutting edge
 dos filos de corte
 Filo doppio



010

Skalpellklingen
Scalpel Blades
Hojas de bisturi
Lame per bisturi

steril
serile
estériles
sterile

passend für Skalpellgriffe / for scalpel handles / para mangos / per i manici .
010-210-004, 010-210-014, 010-210-024, 010-210-034

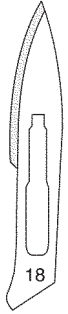

Fig. 18
010-260-018

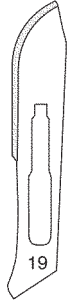

Fig. 19
010-260-019



Fig. 20
010-260-020



Fig. 21
010-260-021

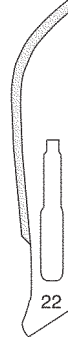

Fig. 22
010-260-022



Fig. 23
010-260-023

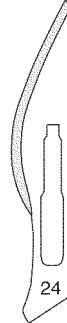

Fig. 24
010-260-024

steril
serile
estériles
sterile

* doppelschneidig
double cutting edge
dos filos de corte
Filo doppio

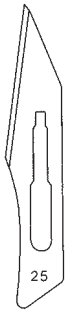

Fig. 25
010-260-025

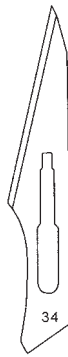

Fig. 34
010-260-034

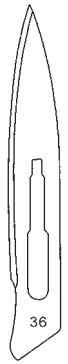

Fig. 36
010-260-036



Fig. 24d
010-261-024

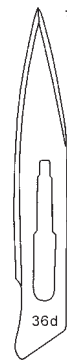
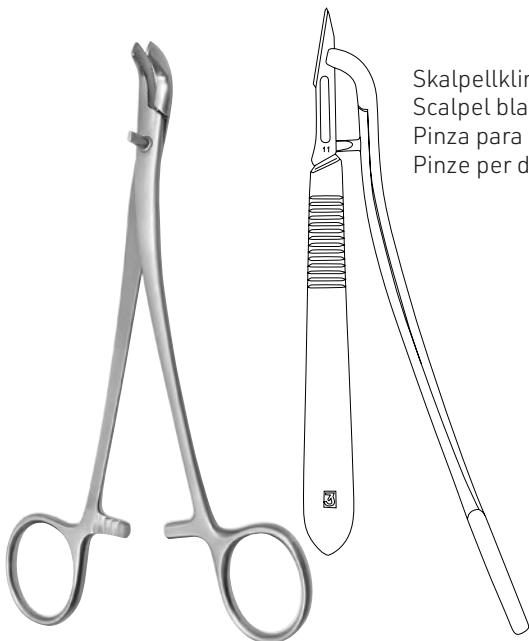

Fig. 36d
010-261-036



Skalpellklingen-Entfernungszange
Scalpel blade removing forceps
Pinza para quitar hojas de bisturías
Pinze per distribuire lame die bisturi



Skalpellklingen-Entferner
Scalpel-Blade Remover
Quita hojas
Distributore lame

010-280-000

010-271-160 16 cm / 6 1/4"



Dermatom, einstellbar von 0,1 bis 2,0 mm, komplett, mit 1 auswechselbarer Klinge und 2 Spannplatten.
 Dermatome, adjustable from 0,1 to 2,0 mm, compl., with 1 interchangeable blade and 2 skin straightening blades
 Dermatomo, graduable de 0,1 hasta 2,0 mm, completo, con 1 hoja intercambiable y 2 placas para extender la piel
 Dermatomi regolabile da 0,1 a 2,0 mm, completo con 2 placche per stendere la pelle ed una lama.

Ersatzklinge
 Spare blade
 Hoja de repuesto
 Lama di ricambio



Spannplatte allein
 Skin straightening plate only
 Placa para extender la piel
 Placca per stendere la pelle



SCHINK

010-350-000 31,0 cm / 12 1/4"

010-350-001

010-350-002



Ersatzklinge
 Spare blade
 Hoja de repuesto
 Lama di ricambio

010-352-001

HUMBY

010-352-000 32,0 cm / 12 1/2"



010

Amputationsmesser, Resektionsmesser
Amputating knives, Resection knives
Cuchillos para amputación y resección
Coltelli per amputazione e resezione



COLIN	A
010-400-130	13,0 cm / 5 ¹ / ₈ "
010-400-160	16,0 cm / 6 ¹ / ₄ "
010-400-190	19,0 cm / 7 ¹ / ₂ "
010-400-220	22,0 cm / 8 ¹ / ₂ "
010-400-280	28,0 cm / 11 ¹ / ₄ "

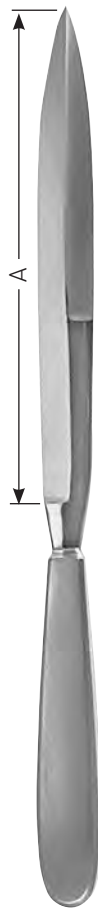

CATLIN	A
010-402-160	16,0 cm / 6 ¹ / ₄ "
010-402-190	19,0 cm / 7 ¹ / ₂ "
010-402-220	22,0 cm / 8 ³ / ₄ "



LISTON	A
010-404-170	17,0 cm / 6 ³ / ₄ "
010-404-200	20,0 cm / 8"



LANGENBECK A
010-406-120 12,0 cm / 4³/₄"

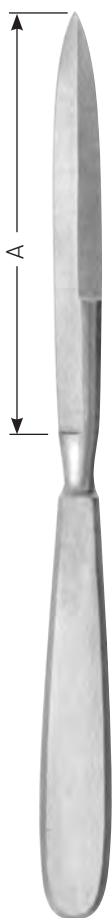

A
010-408-110 11,0 cm / 4¹/₂"



A
010-410-095 9,5 cm / 3³/₄"



010

Rasierklingenhalter und -brecher, Rasierklingen
Blade Holders / Blade Breakers, Razorblades
Porta hojas / Rompe hojas de afeitar, Hojas para afeitar
Pinze per afferare e rompere le lamette de rasoio, Lamette de rasoio



TROUTMAN-CHRIS
010-450-090 9,0 cm / 3 1/2"



TROUTMAN-CHRIS
010-451-090 9,0 cm / 3 1/2"



CASTROVIEJO
010-452-110 11,0 cm / 4 1/2"



CASTROVIEJO
010-454-130 13,0 cm / 5 1/4"

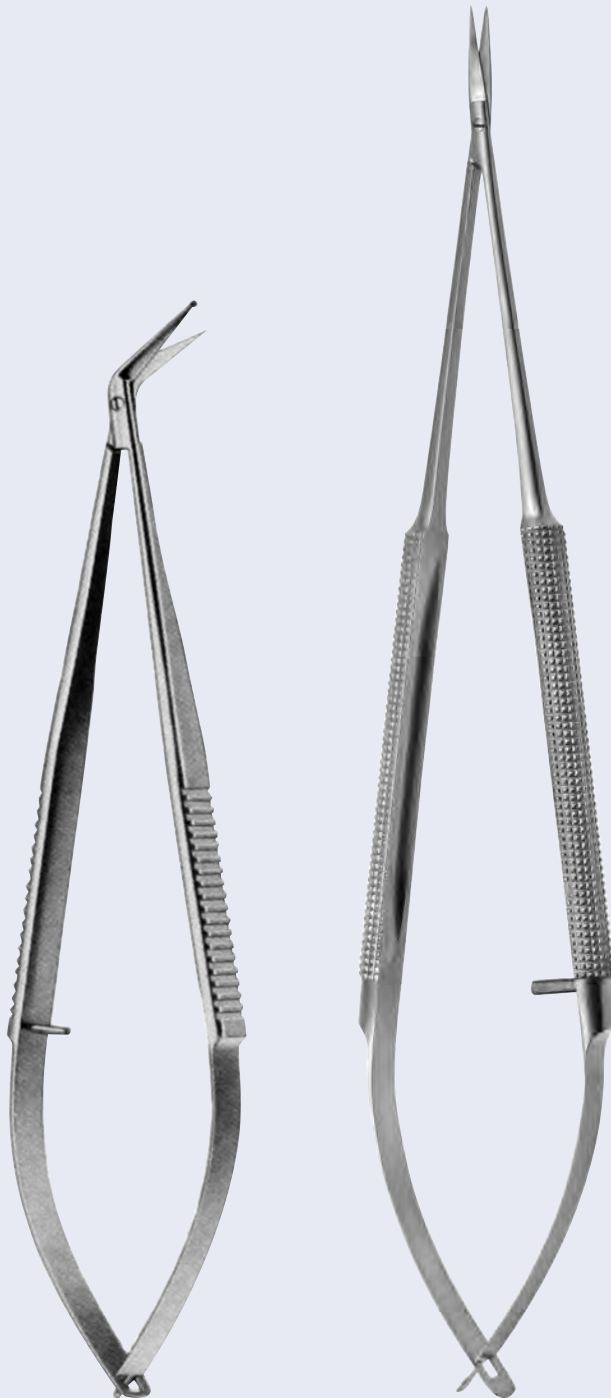

011

Mikro-Scheren
Micro Scissors
Micro Tijeras
Micro Forbici



011

Mikro-Scheren
Micro Scissors
Micro Tijeras
Micro Forbici

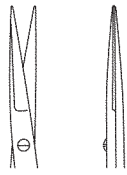

011-100-185

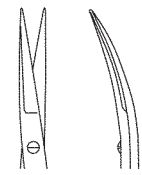

011-101-185

aufgebogen
curved
curva
curve in alto

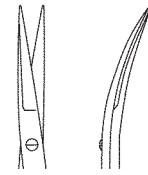

011-103-185

abgebogen
cur. downward
curva hacia abajo
curve basso

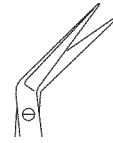

011-105-185

abgewinkelt
angled
acodada
angolato

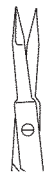

011-106-185



011-107-185

011-100-185 - 011-107-185 18,5 cm / 7 1/2"



JACOBSON

011-100-225



POTTS

011-101-225



011-106-225



011-107-225

011-100-225 - 011-107-225 22,5 cm / 8 3/4"

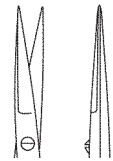

011-110-185

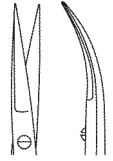

011-111-185



011-113-185

011-110-185 - 011-113-185 18,5 cm / 7 1/2"

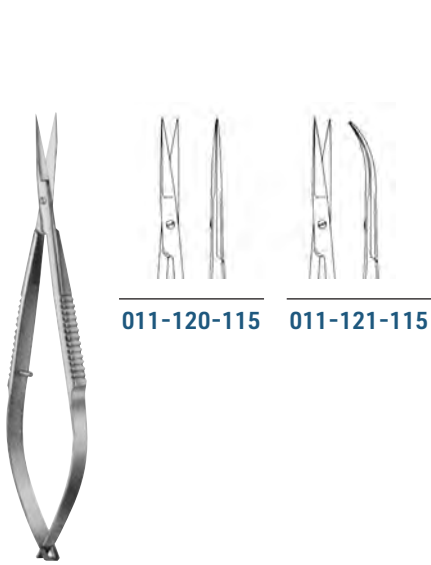

011-120-115

011-121-115

WESTCOTT

011-120-115 11,5 cm / 8³/₄"

011-121-115 11,5 cm / 8³/₄"



011-201-110 11,0 cm / 4¹/₂"



011-204-120 12,0 cm / 5"



GOMEL

011-211-140 14,0 cm / 5¹/₂"

011-211-180 18,0 cm / 6¹/₄"



HEPP/SCHIEDEL

011-221-140 14,0 cm / 5¹/₂"

011-221-160 16,0 cm / 6¹/₄"



011-230-090

011-231-090

011-230-090 9,0 cm / 3¹/₂"

011-231-090 9,0 cm / 3¹/₂"



011

Mikro-Scheren
Micro Scissors
Micro Tijeras
Micro Forbici

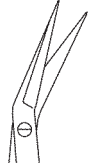

011-251-025

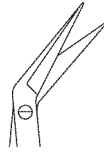

011-251-045

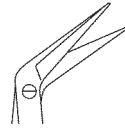

011-251-060



011-251-090



011-251-125

011-251-025 - 011-251-125 18,0 cm / 7"



011-261-025

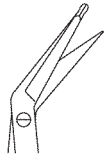

011-261-045

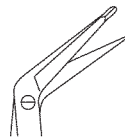

011-261-060

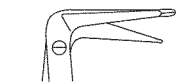

011-261-090



011-261-125

1 Blatt geknöpft
1 probe-pointed blade
1 hoja botonada
1 lama bottonuta

011-261-025 - 011-261-125 18,0 cm / 7"

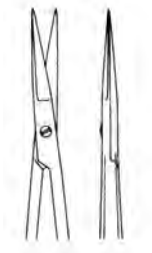

011-270-140

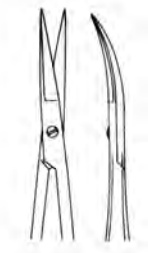

011-271-155



REILL

011-273-155

- 1 Blatt gezahnt
- 1 blade saw edge
- 1 hoja dentada
- 1 lama dentata

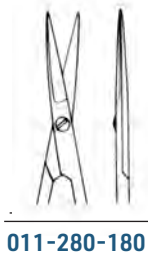

011-280-180

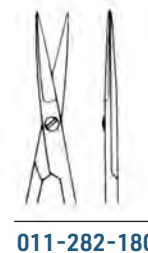

011-282-180

- 1 Blatt gezahnt
- 1 blade saw edge
- 1 hoja dentada
- 1 lama dentata

- 011-270-140** 14 cm / 5 1/2"
- 011-271-155** 15,5 cm / 6"
- 011-273-155** 15,5 cm / 6"

- 011-280-180** 18,0 cm / 7 1/4"
- 011-282-180** 18,0 cm / 7 1/4"

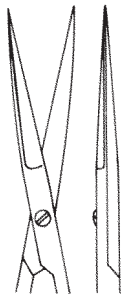
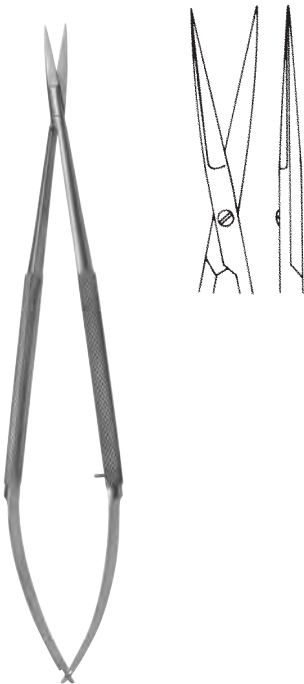

HEPP/SCHIEDEL

011-290-180 18,0 cm / 7 1/4"



011-291-180 18,0 cm / 7 1/4"



HEPP/SCHIEDEL

011-293-180 18,0 cm / 7 1/4"



011



012

Scheren
Scissors
Tijeras
Forbici





012

Chirurgische Scheren
Surgical Scissors
Tijeras para cirugía
Forbici per chirurgia

gerade • straight • rectas • retto



STANDARD

012-100-105	10,5 cm / 4 1/4"
012-100-115	11,5 cm / 4 1/2"
012-100-130	13,0 cm / 5 1/8"
012-100-145	14,5 cm / 5 3/4"
012-100-155	15,5 cm / 6"
012-100-165	16,5 cm / 6 1/2"
012-100-175	17,5 cm / 7"
012-100-185	18,5 cm / 7 1/4"
012-100-200	20,0 cm / 8"

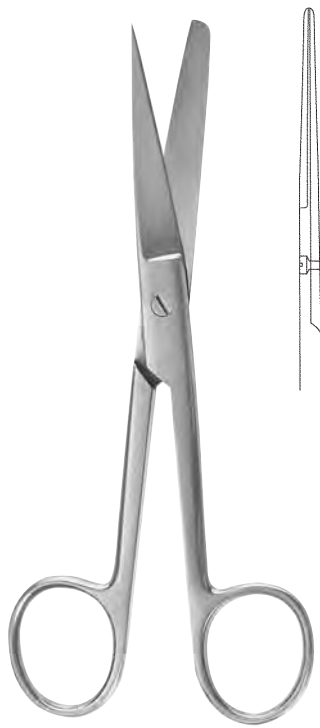

STANDARD

012-102-105	10,5 cm / 4 1/4"
012-102-115	11,5 cm / 4 1/2"
012-102-130	13,0 cm / 5 1/8"
012-102-145	14,5 cm / 5 3/4"
012-102-155	15,5 cm / 6"
012-102-165	16,5 cm / 6 1/2"
012-102-175	17,5 cm / 7"
012-102-185	18,5 cm / 7 1/4"
012-102-200	20,0 cm / 8"

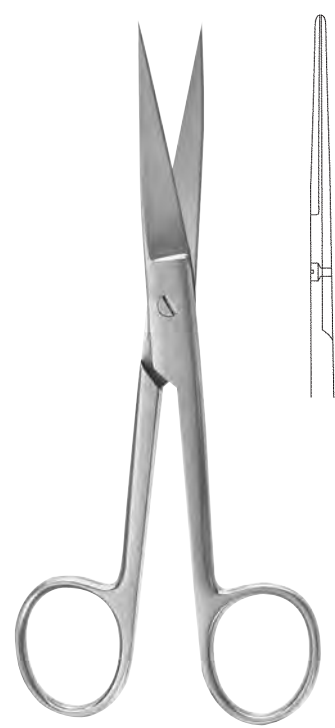

STANDARD

012-104-105	10,5 cm / 4 1/4"
012-104-115	11,5 cm / 4 1/2"
012-104-130	13,0 cm / 5 1/8"
012-104-145	14,5 cm / 5 3/4"
012-104-155	15,5 cm / 6"
012-104-165	16,5 cm / 6 1/2"
012-104-175	17,5 cm / 7"
012-104-185	18,5 cm / 7 1/4"
012-104-200	20,0 cm / 8"

gebogen • curved • curvas • curve



STANDARD

012-101-115	11,5 cm / 4 1/2"
012-101-130	13,0 cm / 5 1/8"
012-101-145	14,5 cm / 5 3/4"
012-101-155	15,5 cm / 6"
012-101-165	16,5 cm / 6 1/2"
012-101-175	17,5 cm / 7"
012-101-185	18,5 cm / 7 1/4"
012-101-200	20,0 cm / 8"

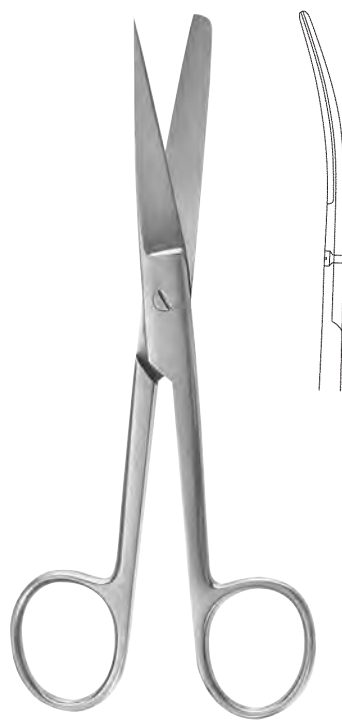

STANDARD

012-103-115	11,5 cm / 4 1/2"
012-103-130	13,0 cm / 5 1/8"
012-103-145	14,5 cm / 5 3/4"
012-103-155	15,5 cm / 6"
012-103-165	16,5 cm / 6 1/2"
012-103-175	17,5 cm / 7"
012-103-185	18,5 cm / 7 1/4"
012-103-200	20,0 cm / 8"

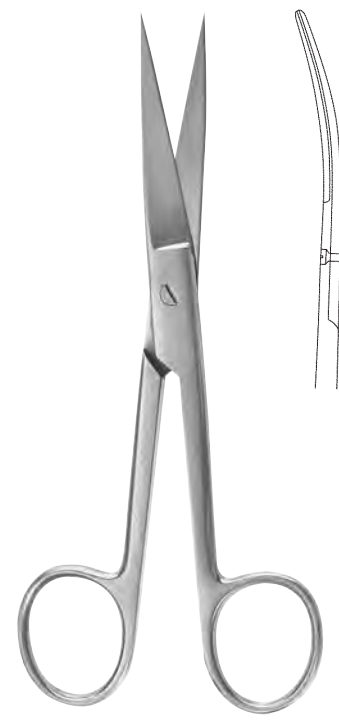

STANDARD

012-105-115	11,5 cm / 4 1/2"
012-105-130	13,0 cm / 5 1/8"
012-105-145	14,5 cm / 5 3/4"
012-105-155	15,5 cm / 6"
012-105-165	16,5 cm / 6 1/2"
012-105-175	17,5 cm / 7"
012-105-185	18,5 cm / 7 1/4"
012-105-200	20,0 cm / 8"



012

Chirurgische Scheren
Surgical Scissors
Tijeras para cirugía
Forbici per chirurgia



GRAZIL

012-110-130 13,0 cm / 5¹/₈"
012-110-145 14,5 cm / 5³/₄"



GRAZIL

012-111-130 13,0 cm / 5¹/₈"
012-111-145 14,5 cm / 5³/₄"



GRAZIL

012-112-130 13,0 cm / 5¹/₈"
012-112-145 14,5 cm / 5³/₄"



GRAZIL

012-113-130 13,0 cm / 5¹/₈"
012-113-145 14,5 cm / 5³/₄"



GRAZIL

012-114-130 13,0 cm / 5¹/₈"
012-114-145 14,5 cm / 5³/₄"



GRAZIL

012-115-130 13,0 cm / 5¹/₈"
012-115-145 14,5 cm / 5³/₄"



INCISION

012-120-130 13,0 cm / 5 1/8"
012-120-145 14,5 cm / 5 3/4"



DEAVER

012-130-140 14,0 cm / 5 1/2"

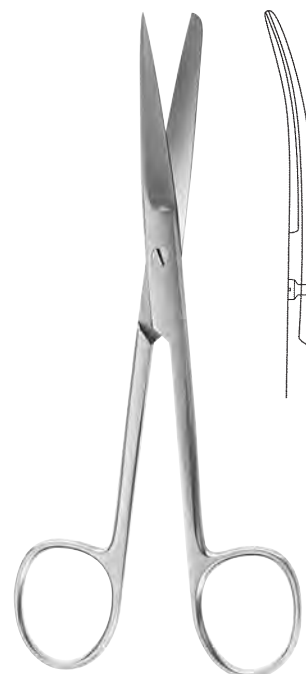

DEAVER

012-131-140 14,0 cm / 5 1/2"

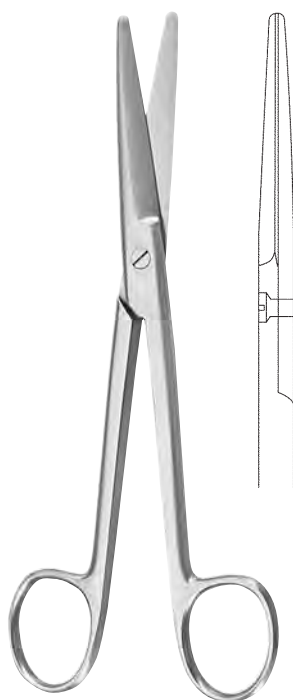

MAYO

012-140-145 14,5 cm / 5 3/4"
012-140-155 15,5 cm / 6"
012-140-170 17,0 cm / 6 3/4"
012-140-230 23,0 cm / 9"

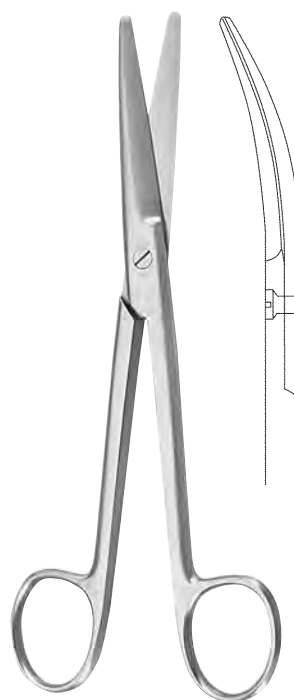

MAYO

012-141-145 14,5 cm / 5 3/4"
012-141-155 15,5 cm / 6"
012-141-170 17,0 cm / 6 3/4"
012-141-230 23,0 cm / 9"



012

Chirurgische Scheren
Surgical Scissors
Tijeras para cirugía
Forbici per chirurgia

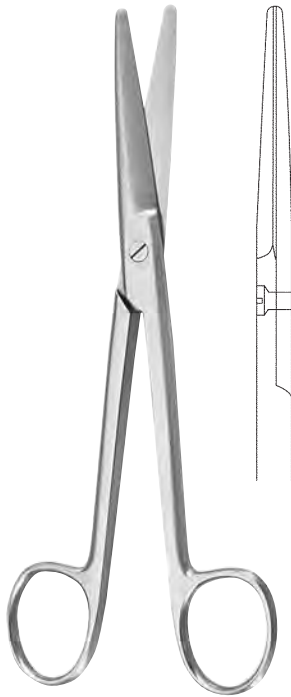

MAYO-HARRINGTON

012-142-225 22,5 cm / 9"

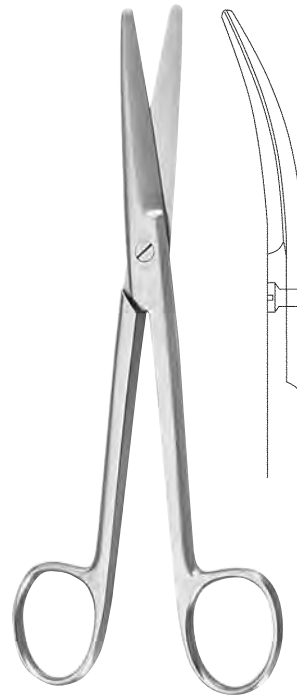

MAYO-HARRINGTON

012-143-225 22,5 cm / 9"
012-143-280 28,0 cm / 11"

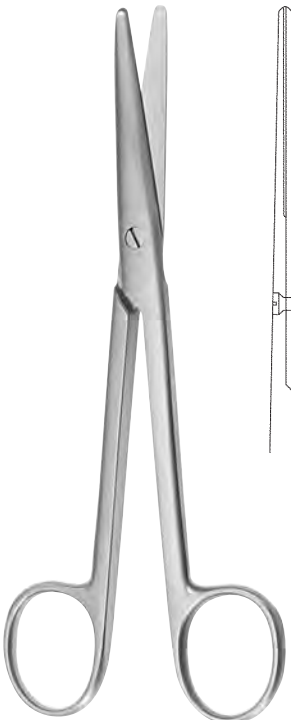

MAYO-STILLE

012-150-150 15,0 cm / 6"
012-150-170 17,0 cm / 6³/₄"
012-150-190 19,0 cm / 7¹/₂"
012-150-210 21,0 cm / 8¹/₄"



MAYO-STILLE

012-151-150 15,0 cm / 6"
012-151-170 17,0 cm / 6³/₄"
012-151-190 19,0 cm / 7¹/₂"
012-151-210 21,0 cm / 8¹/₄"



MAYO-NOBLE

012-154-170 17,0 cm / 6³/₄"



MAYO-NOBLE

012-155-170 17,0 cm / 6³/₄"

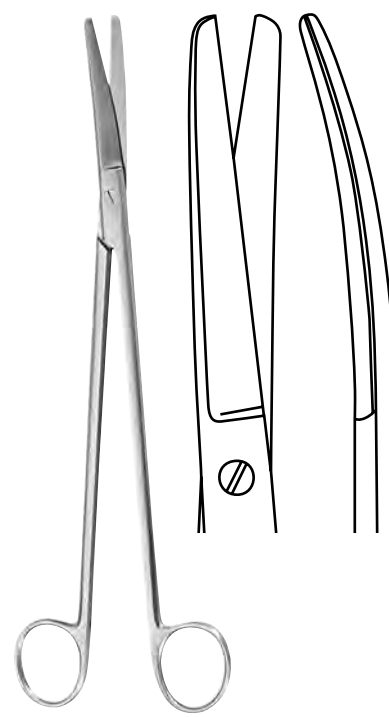

WERTHEIM

012-159-145 14,5 cm / 5¹/₂"
012-159-195 19,5 cm / 7³/₄"
012-159-225 22,5 cm / 9"

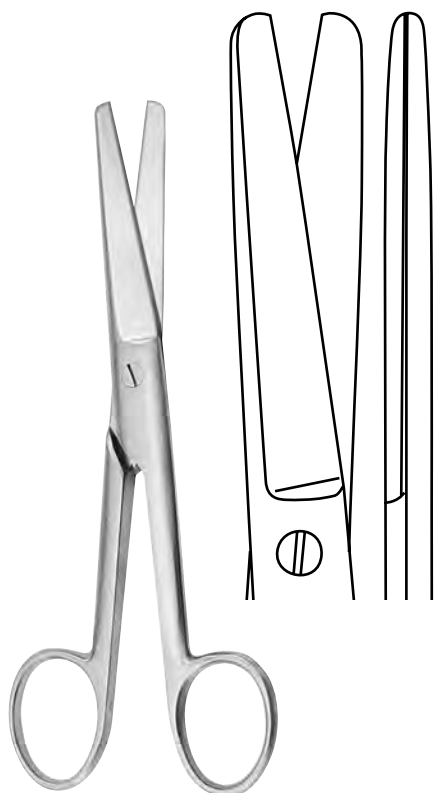

DOYEN

012-160-175 17,5 cm / 7"

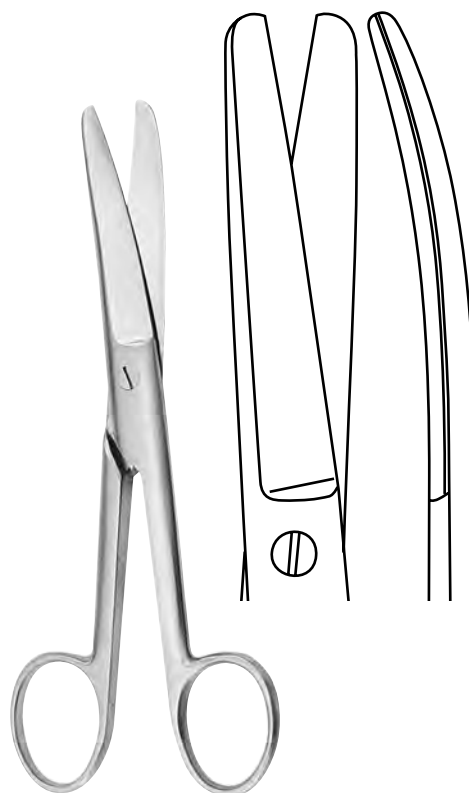

DOYEN

012-161-175 17,5 cm / 7"



012

Gynäkologische Scheren
Gynecological Scissors
Tijeras para ginecología
Forbici per ginecologia

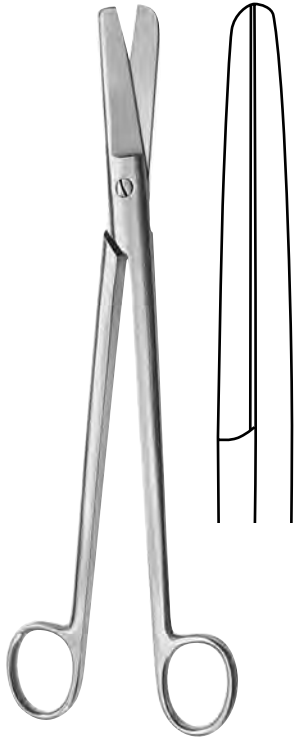

DUBOIS
012-160-270 27,0 cm / 10⁵/₈"

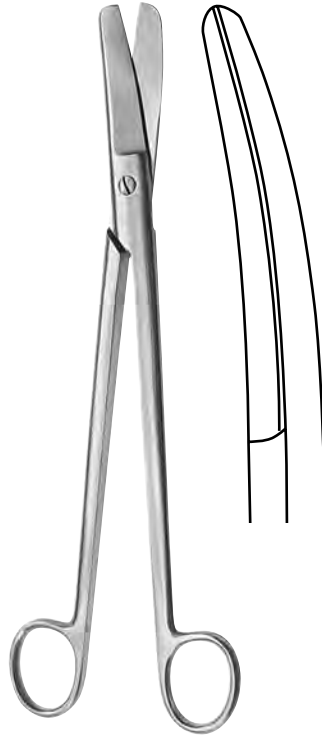

DUBOIS
012-161-270 27,0 cm / 10⁵/₈"



BOZEMANN
012-163-220 22,0 cm / 8³/₄"



SIEBOLD
012-165-240 24,0 cm / 9¹/₂"

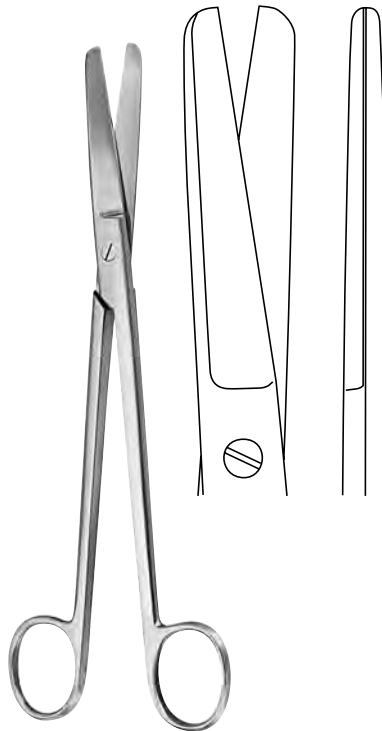

SIMS
012-166-200 20,0 cm / 8"
012-166-230 23,0 cm / 9"

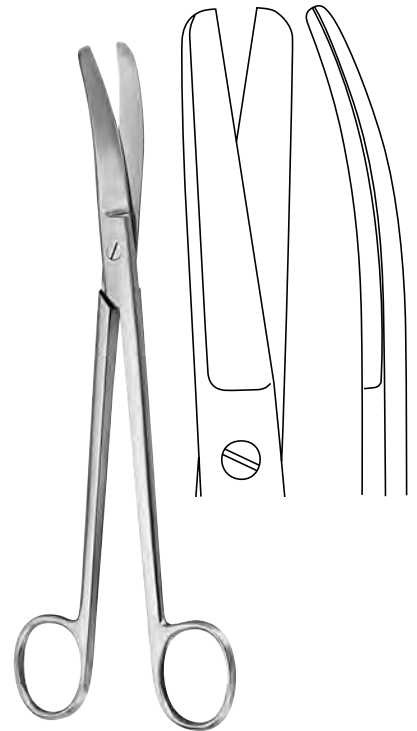

SIMS
012-167-200 20,0 cm / 8"
012-167-230 23,0 cm / 9"



BRAUN-STADLER

012-169-140 14,0 cm / 5 1/2"
012-169-220 22,0 cm / 8 3/4"



BUSCH

012-171-130 13,0 cm / 5 1/8"
012-171-160 16,0 cm / 6 1/4"



MOD. USA

012-173-105 10,5 cm / 4 1/8"



SCHUMACHER

012-175-160 16,0 cm / 6 1/4"



WALDMANN

012-177-180 18,0 cm / 7"

Episiotomiescheren
 Episiotomy scissors
 Tijeras para episiotomía
 Forbici per episiotomia



Episiotomiescheren
 Episiotomy scissors
 Tijeras para episiotomía
 Forbici per episiotomia

gezahnt
 toothed
 dentada
 dentate

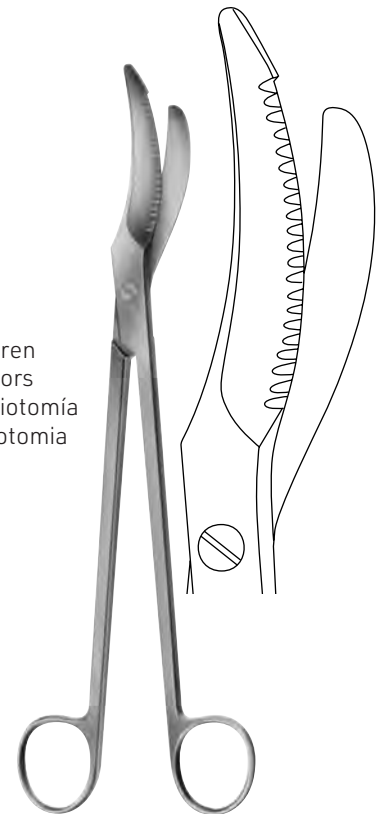

012-181-240 24,0 cm / 9 1/2"



012

Präparierscheren
Dissecting Scissors
Tijeras de disección
Forbici per dissezione



METZENBAUM-BABY

012-200-115 11,5 cm / 4 1/2"



METZENBAUM-BABY

012-201-115 11,5 cm / 4 1/2"

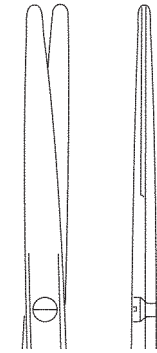

012-202-145



012-203-145

METZENBAUM

012-202-145 - 012-203-145 14,5 cm / 5 1/2"

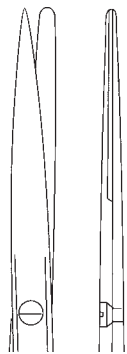

012-204-145

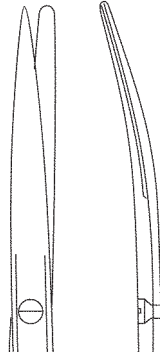

012-205-145

METZENBAUM

012-204-145 - 012-205-145 14,5 cm / 5 1/2"

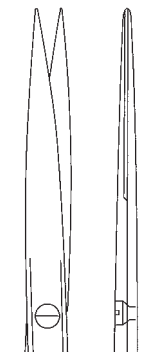

012-206-145

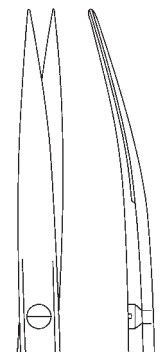

012-207-145

METZENBAUM

012-206-145 - 012-207-145 14,5 cm / 5 1/2"



METZENBAUM-NELSON

012-210-180	18,0 cm / 7"
012-210-200	20,0 cm / 8"
012-210-230	23,0 cm / 9"
012-210-250	25,0 cm / 10"
012-210-280	28,0 cm / 11"
012-210-300	30,0 cm / 12"



METZENBAUM-NELSON

012-211-180	18,0 cm / 7"
012-211-200	20,0 cm / 8"
012-211-230	23,0 cm / 9"
012-211-250	25,0 cm / 10"
012-211-280	28,0 cm / 11"
012-211-300	30,0 cm / 12"



012

Präparierscheren
Dissecting Scissors
Tijeras de disección
Forbici per dissezione

Nerv-Präparierscheren • Nerve-Dissecting Scissors
Tijeras para disección de nervios • Forbici per nervi



012-214-150 15,0 cm / 6"



012-215-150 15,0 cm / 6"

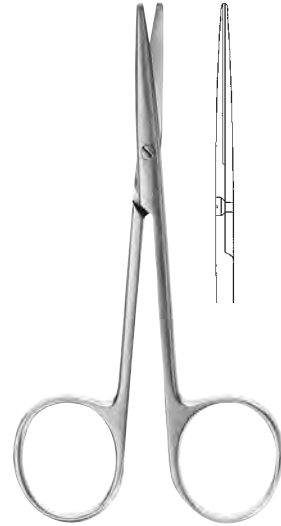

LEXER-BABY
012-220-100 10,0 cm / 4"

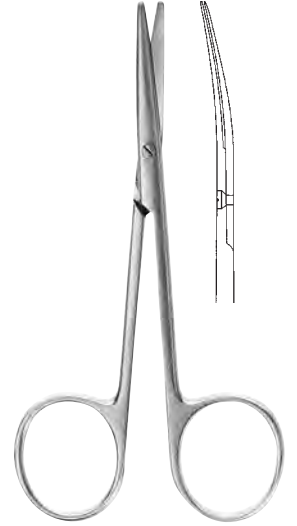

LEXER-BABY
012-221-100 10,0 cm / 4"

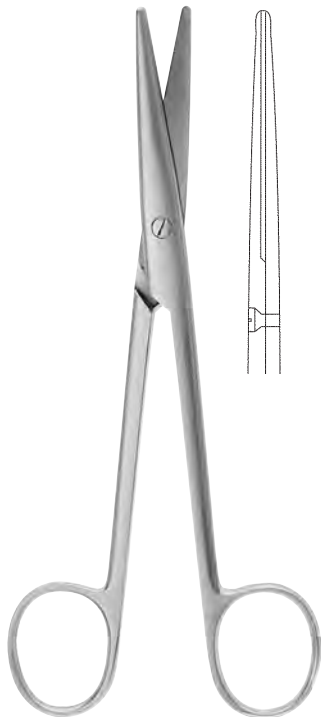

LEXER
012-220-160 16,0 cm / 6 1/4"
012-220-210 21,0 cm / 8 1/4"



LEXER
012-221-160 16,0 cm / 6 1/4"
012-221-210 21,0 cm / 8 1/4"



012-230-160



012-231-160

LEXER-FINO

012-230-160 - 012-231-160 16,0 cm / 6¹/₄"

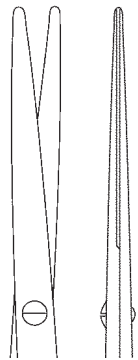

012-240-145

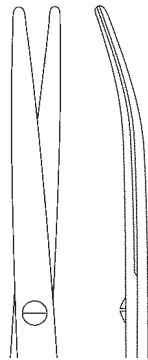

012-241-145

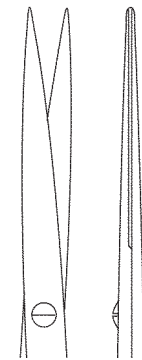

012-242-145

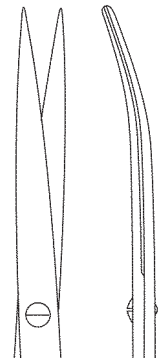

012-243-145



METZENBAUM-FINO

012-240-145 - 012-241-145 14,5 cm / 5³/₄"

METZENBAUM-FINO

012-242-145 - 012-243-145 14,5 cm / 5³/₄"



012

Präparierscheren
Dissecting Scissors
Tijeras para disección
Forbici per dissezione

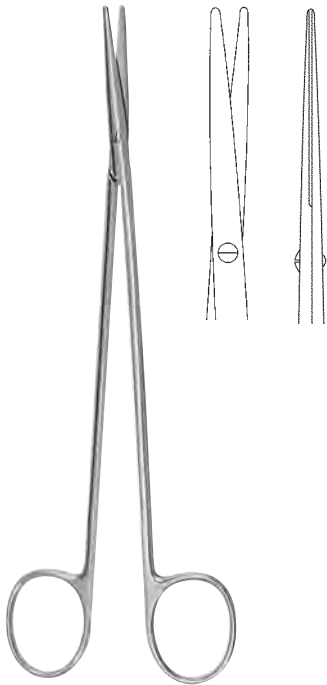

METZENBAUM-FINO

- 012-244-180** 18,0 cm / 7"
- 012-244-200** 20,0 cm / 8"
- 012-244-230** 23,0 cm / 9"

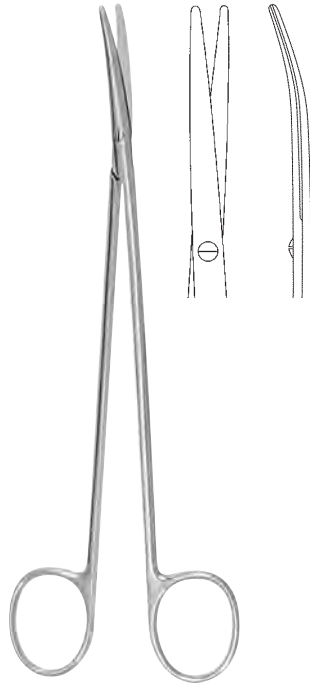

METZENBAUM-FINO

- 012-245-180** 18,0 cm / 7"
- 012-245-200** 20,0 cm / 8"
- 012-245-230** 23,0 cm / 9"

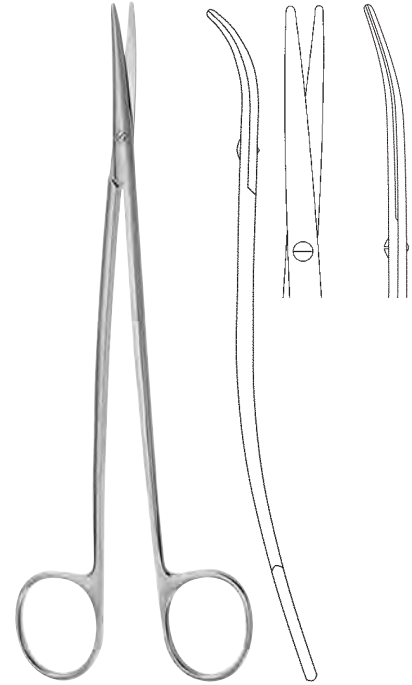

METZENBAUM-FINO S

- 012-247-180** 18,0 cm / 7"
- 012-247-200** 20,0 cm / 8"
- 012-247-230** 23,0 cm / 9"



THOREK

- 012-251-190** 19,0 cm / 7 1/2"

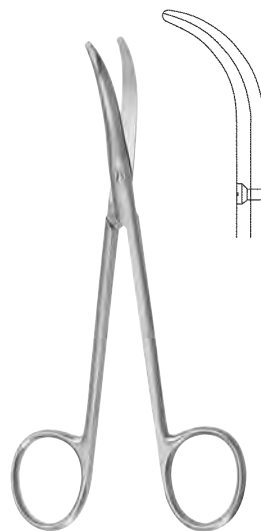

FOMON

- 012-253-135** 13,5 cm / 5 1/8"



ENUCLEATION

- 012-255-110** 11,0 cm / 4 3/8"

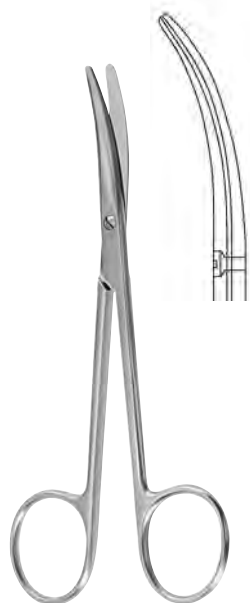

LANDOLT

012-257-125 12,5 cm / 5"



LANDOLT

012-259-125 12,5 cm / 5"

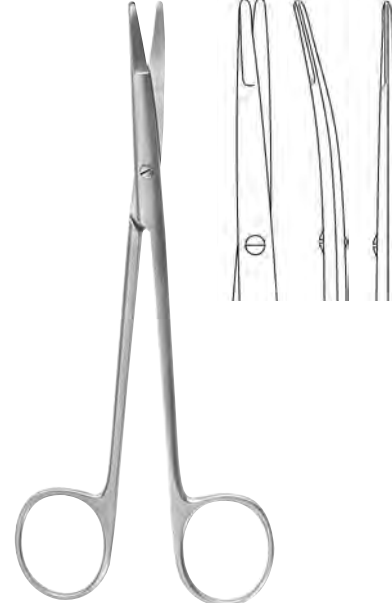

KILNER

012-261-120 12,0 cm / 4³/₄"
012-261-150 15,0 cm / 6"

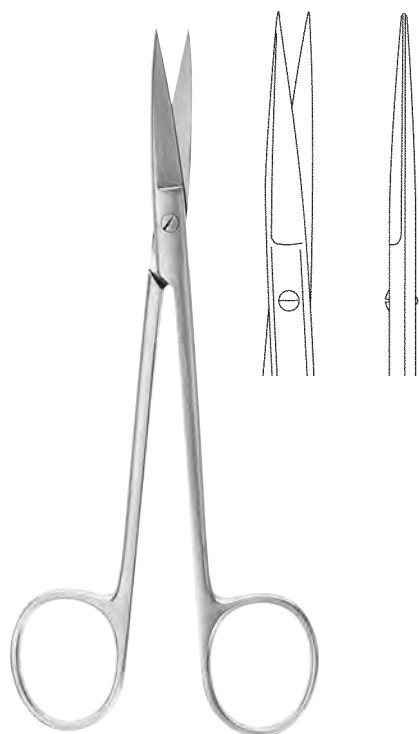

JOSEPH

012-262-140 14,0 cm / 5¹/₂"

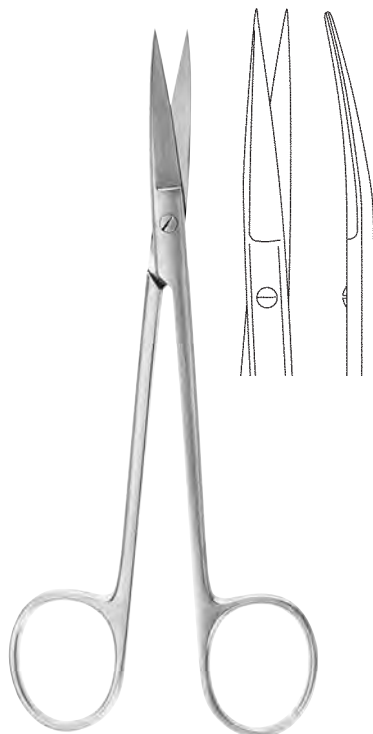

JOSEPH

012-263-140 14,0 cm / 5¹/₂"



012

Feine chirurgische Scheren
Delicate Surgical Scissors
Tijeras finas para cirugía
Forbici fine per chirurgia



BROPHY-SULLIVAN

012-264-140 14,0 cm / 5 1/2"



BROPHY-SULLIVAN

012-265-140 14,0 cm / 5 1/2"

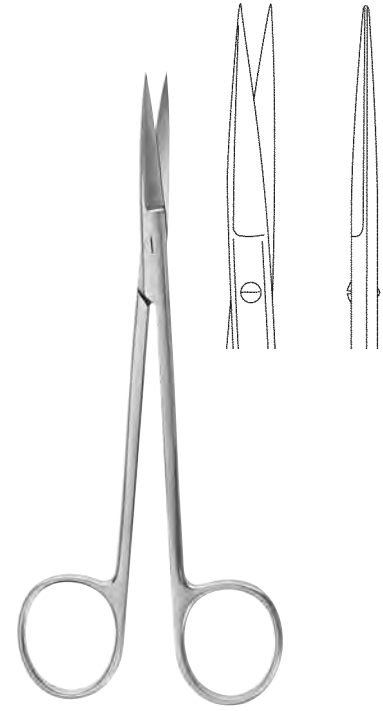

SANVENERO

012-266-140 14,0 cm / 5 1/2"

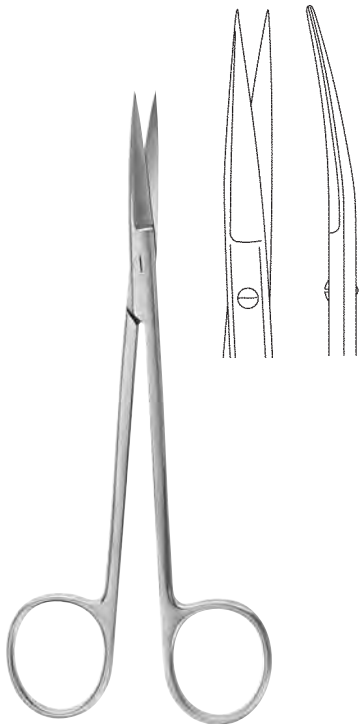

SANVENERO

012-267-140 14,0 cm / 5 1/2"

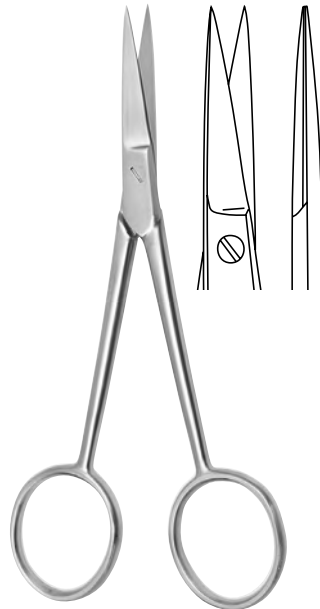

012-268-110 11,0 cm / 4 3/8"

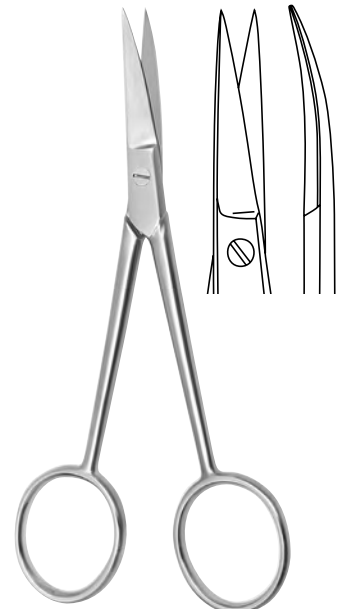

012-269-110 11,0 cm / 4 3/8"

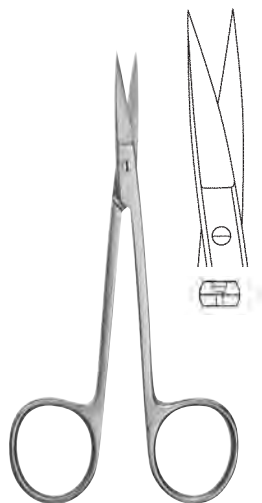

IRIS

- 012-270-090** 9,0 cm / 3 1/2"
- 012-270-105** 10,5 cm / 4 1/8"
- 012-270-115** 11,5 cm / 4 1/2"

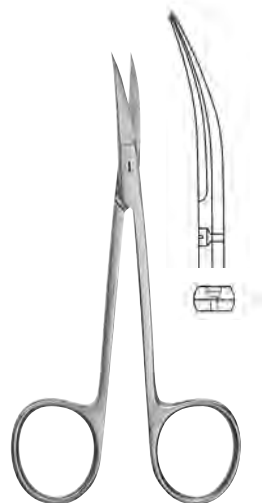

IRIS

- 012-271-090** 9,0 cm / 3 1/2"
- 012-271-105** 10,5 cm / 4 1/8"
- 012-271-115** 11,5 cm / 4 1/2"



- 012-273-115** 11,5 cm / 4 1/2"



- 012-275-115** 11,5 cm / 4 1/2"

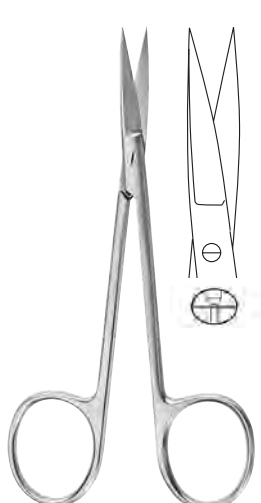

IRIS

- 012-276-090** 9,0 cm / 3 1/2"
- 012-276-105** 10,5 cm / 4 1/8"
- 012-276-115** 11,5 cm / 4 1/2"

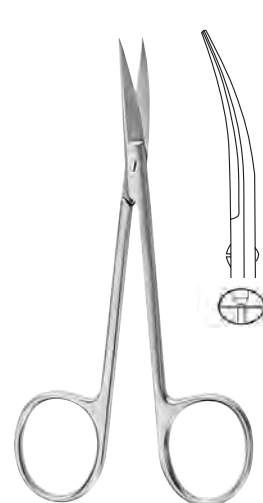

IRIS

- 012-277-090** 9,0 cm / 3 1/2"
- 012-277-105** 10,5 cm / 4 1/8"
- 012-277-115** 11,5 cm / 4 1/2"



012

Feine chirurgische Scheren
Delicate Surgical Scissors
Tijeras finas para cirugía
Forbici fine per chirurgia



STEVENS
012-280-115 11,5 cm / 4 1/2"



STEVENS
012-281-115 11,5 cm / 4 1/2"



STEVENS
012-282-115 11,5 cm / 4 1/2"

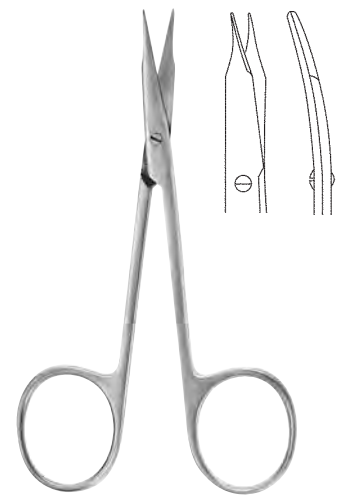

STEVENS
012-283-115 11,5 cm / 4 1/2"



MOD. BONN
012-284-080 8,0 cm / 3 1/4"



MOD. BONN
012-285-080 8,0 cm, 3 1/4"

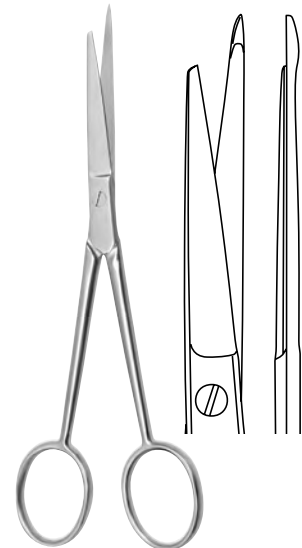

012-286-145 14,5 cm / 5 3/4"

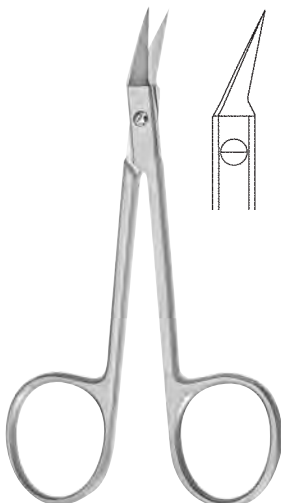

O'BRIAN
012-287-095 9,5 cm / 3 3/4"



STRABISMUS
012-288-115 11,5 cm / 4 1/2"



STRABISMUS
012-289-115 11,5 cm / 4 1/2"



WAGNER

012-290-120 12,0 cm / 4 3/4"



WAGNER

012-291-120 12,0 cm / 4 3/4"

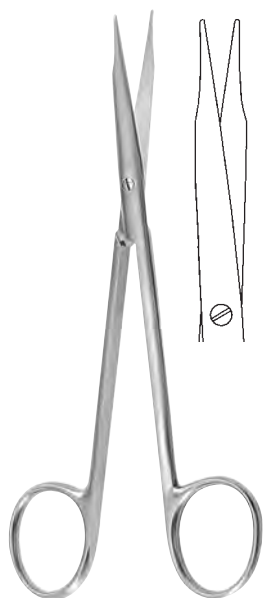

REYNOLDS

012-292-150 15,0 cm / 6"

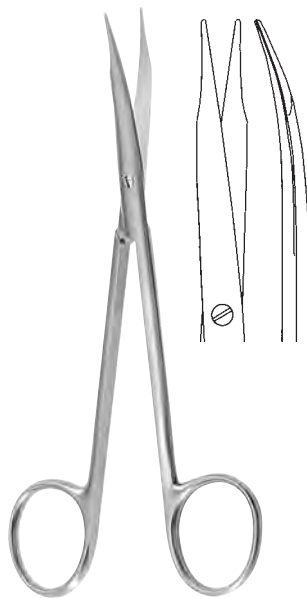

REYNOLDS

012-293-150 15,0 cm / 6"

012-293-175 17,5 cm / 6"

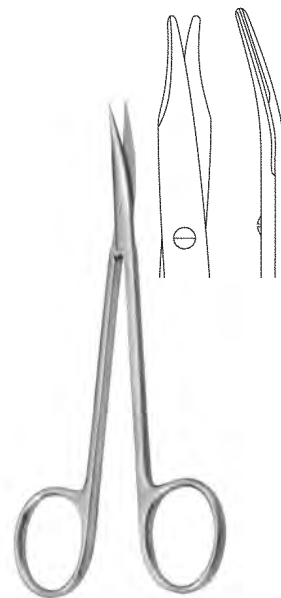

JAMESON

012-295-150 15,0 cm / 6"



012

Feine chirurgische Scheren, Gefäßscheren
Delicate Surgical Scissors, Vascular Scissors
Tijeras finas para cirugía, Tijeras vasculares
Forbici fine per chirurgia, Forbici vascolari

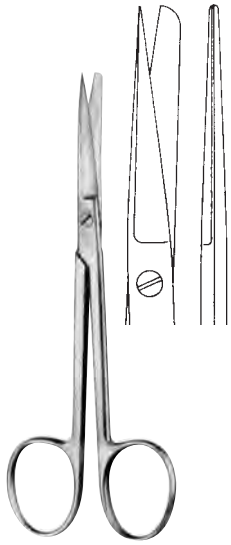

012-296-120 12,0 cm / 4³/₄"

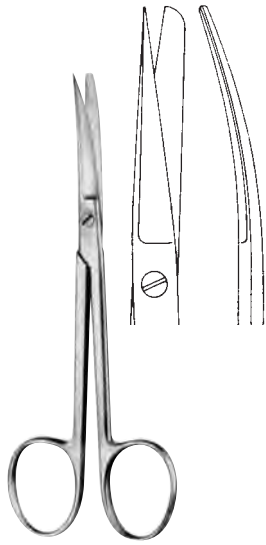

012-297-120 12,0 cm / 4³/₄"

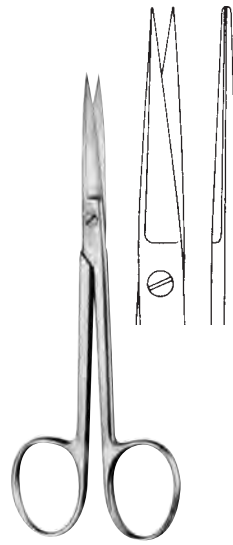

012-298-120 12,0 cm / 4³/₄"

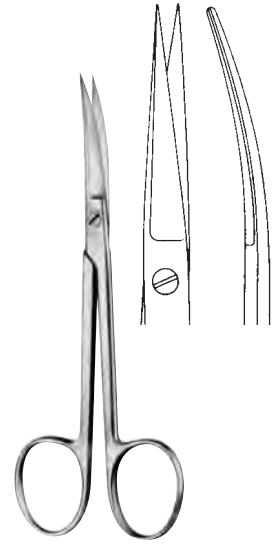

012-299-120 12,0 cm / 4³/₄"

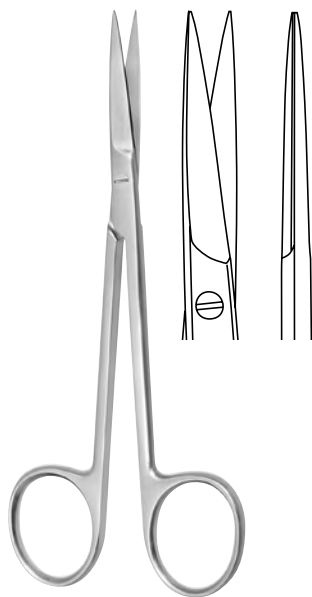

012-298-130 13,0 cm / 5¹/₈"

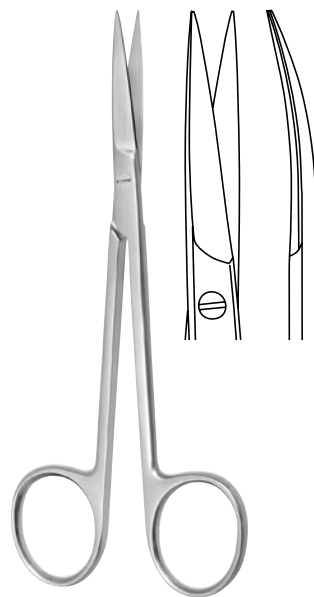

012-299-130 13,0 cm / 5¹/₈"

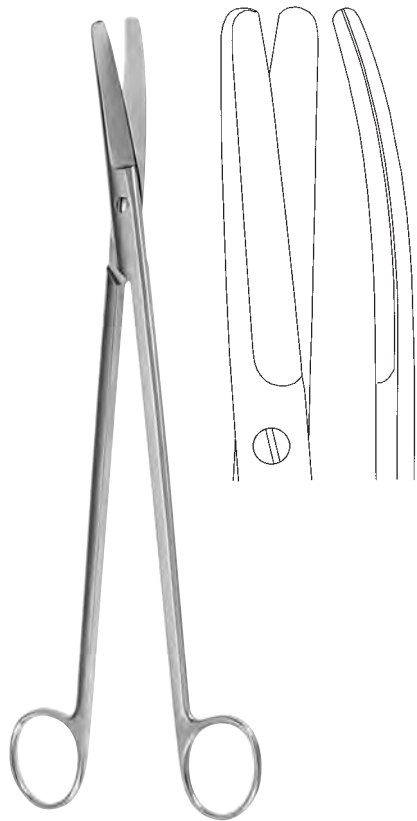

CRAFOORD

012-301-300 30,0 cm / 12"

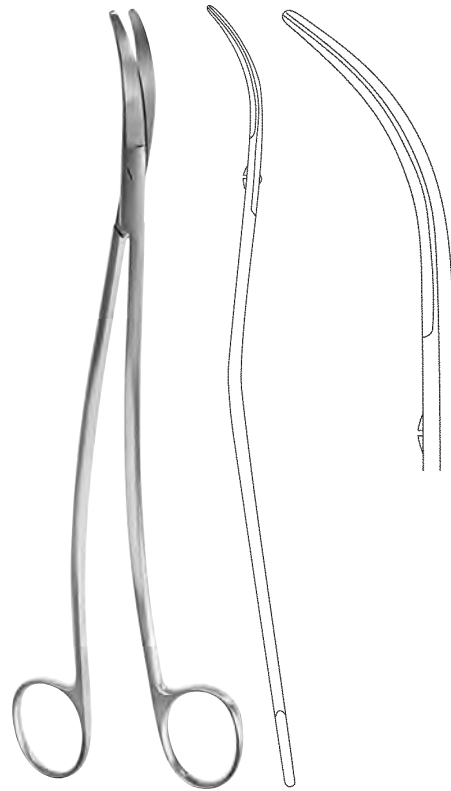

SATINSKY

012-303-245 24,5 cm / 9³/₄"

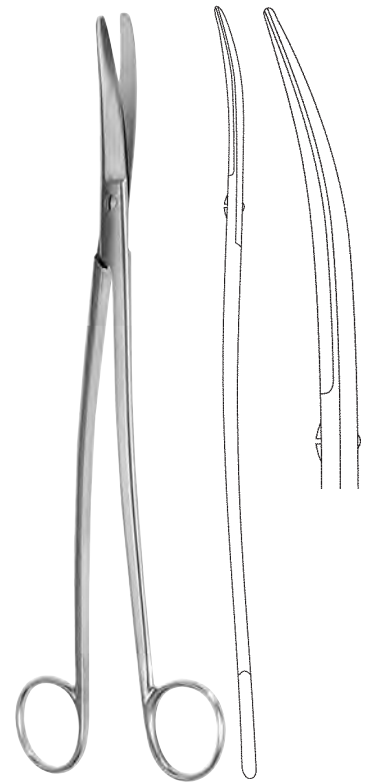

KLINGENBERG-LOTH

012-305-230 23,0 cm / 9"

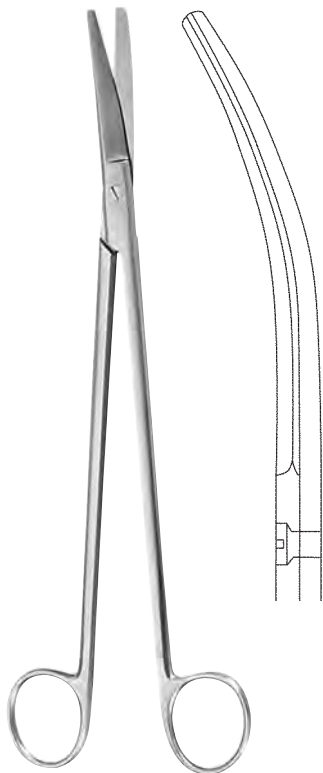

LLOYD-DAVIS

012-311-270 27,0 cm / 10⁵/₈"

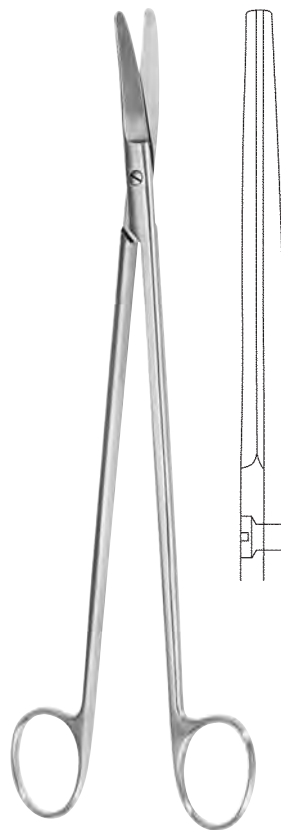

STELZNER

012-312-310 31,0 cm / 12¹/₄"

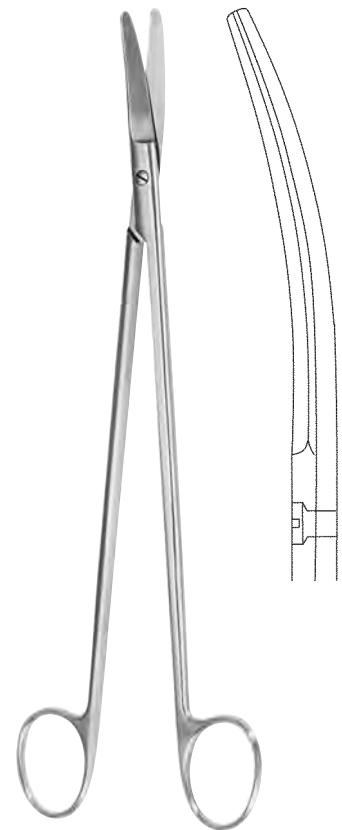

STELZNER

012-313-310 31,0 cm / 12¹/₄"



012

Lungenlappen- und Rektumscheren
Lobectomy and Rectal Scissors
Tijeras para lobectomía y recto
Forbici per lobo polmonare e per il retto

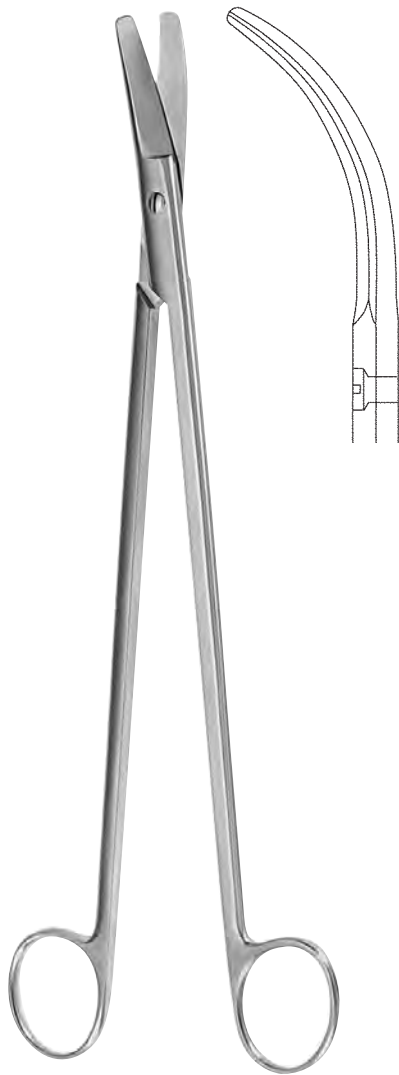

RECTAL

012-315-325 32,5 cm / 12³/₄"



FINOCHIETTO

012-317-270 27,0 cm / 10⁵/₈"

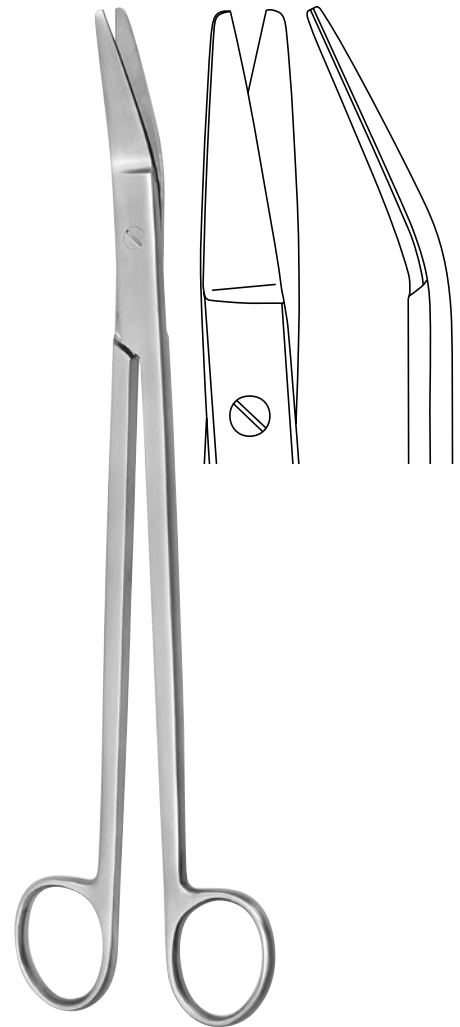

RESANO

012-319-250 25,0 cm / 9³/₄"

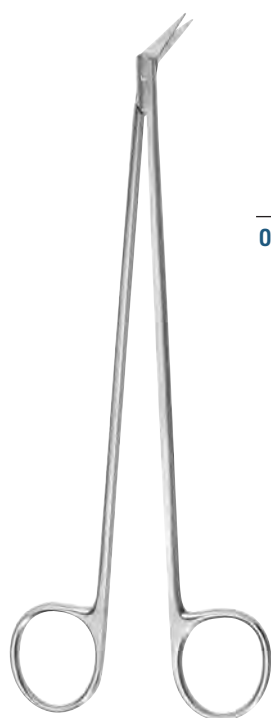

012-331-025



012-331-045



012-331-060

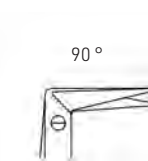

012-331-090



012-331-125

DIETRICH

012-331-025 - 012-331-125 19,0 cm / 7 1/2"



DIETRICH-HEGEMANN

012-333-125 19,0 cm / 7 1/2"

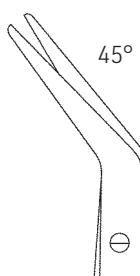
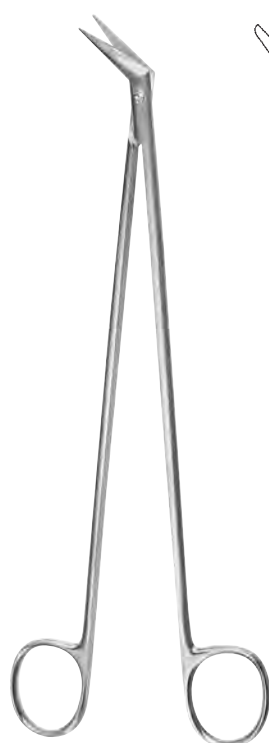

012-335-045

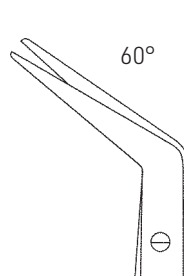

012-335-060

DE BAKEY

012-335-045 16,5 cm / 6 1/2"

012-335-060 16,0 cm / 6 1/4"



012

Gefäßscheren
Vascular Scissors
Tijeras vasculares
Forbici vascolari

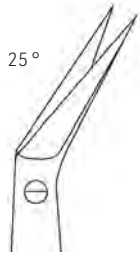

012-337-025

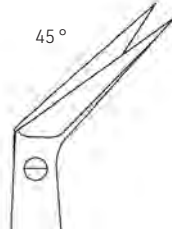

012-337-045

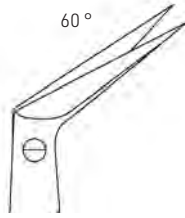

012-337-060

POTTS-SMITH

012-337-025 - 012-337-060 19,0 cm / 7 1/2"

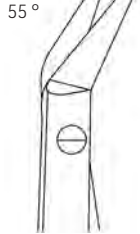
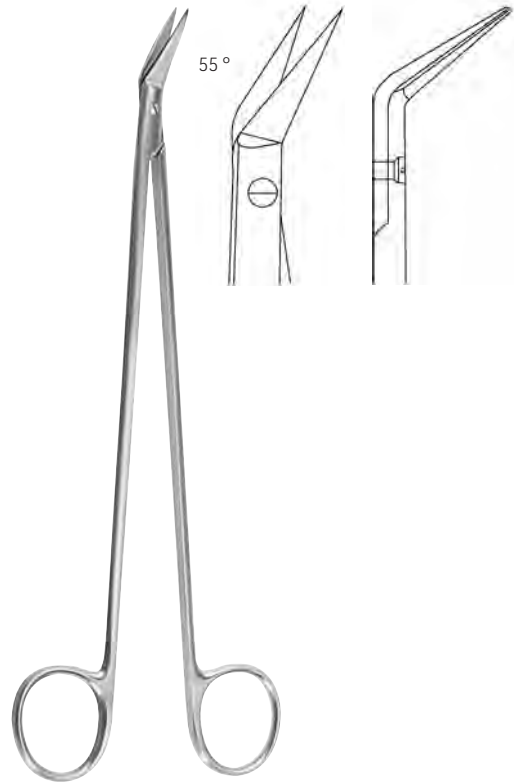

POTTS-SMITH

012-339-055 18,0 cm / 7"

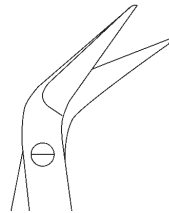
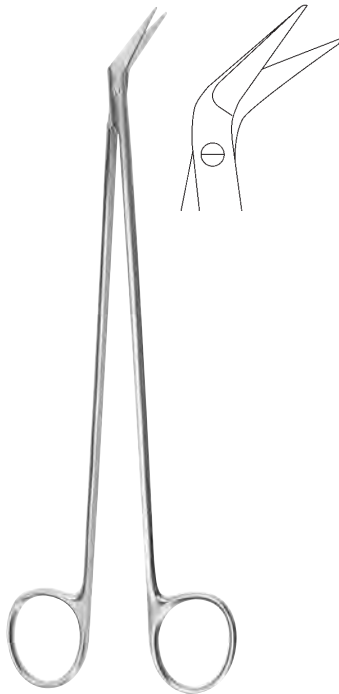

POTTS DE MARTEL

012-441-210 21,0 cm / 8 1/4"
012-441-240 24,0 cm / 9 1/2"

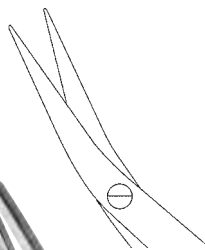
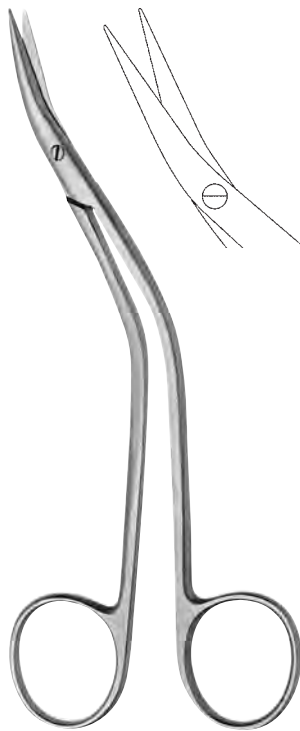

DE BAKEY

012-443-155 15,5 cm / 6"

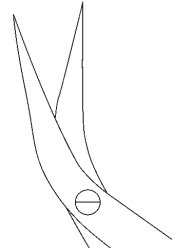
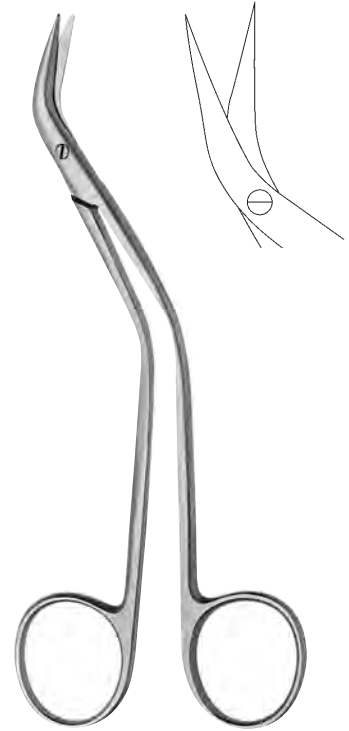

DE BAKEY

012-445-155 15,5 cm / 6"

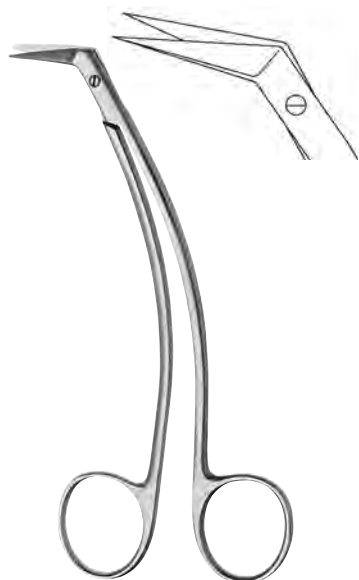

FAVALORO

012-447-155 15,5 cm / 6"

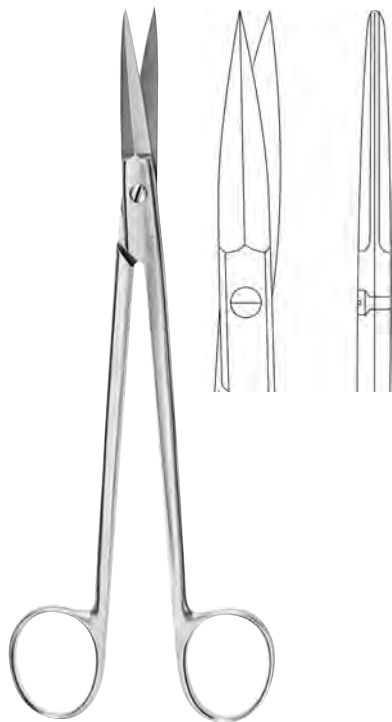

MC INDOE

012-448-190 19,0 cm / 7 1/2"



geknöpftes Blatt
 probe-pointed blade
 punta botonada
 lame bottonuta

012-450-115 11,5 cm / 4 1/2"

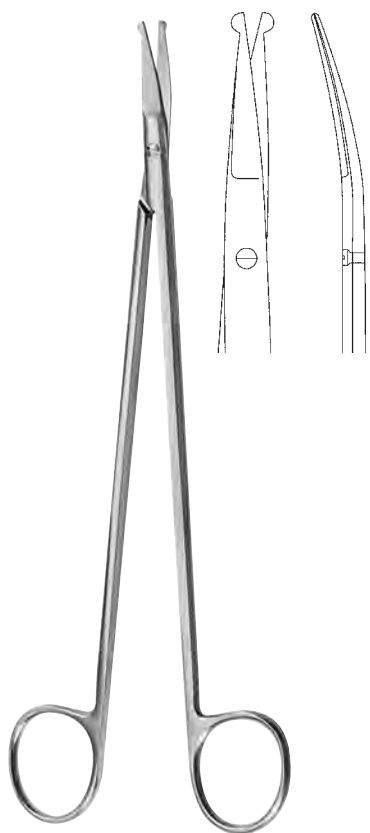

STRULLY

012-461-220 22,0 cm / 8 5/8"

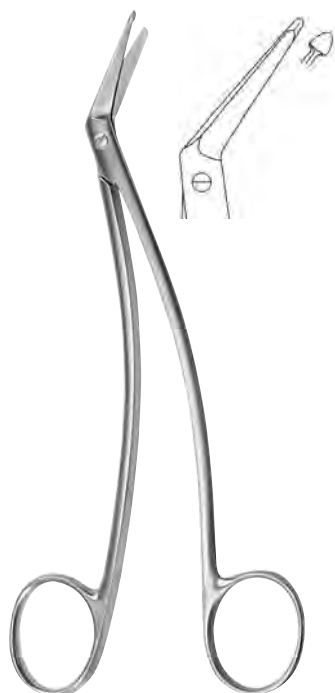

SCHMIEDEN-TAYLOR

012-463-170 17,0 cm / 6 3/4"

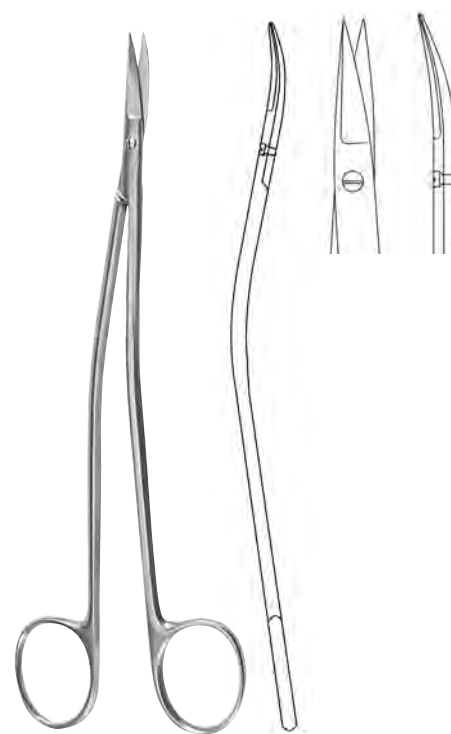

DANDY

012-465-170 17,0 cm / 6 3/4"



012

Gefäßscheren
Vascular Scissors
Tijeras vasculares
Forbici vascolari



012-466-180

012-467-180

TOENNIS

012-466-180 - 012-467-180 18,0 cm / 7"

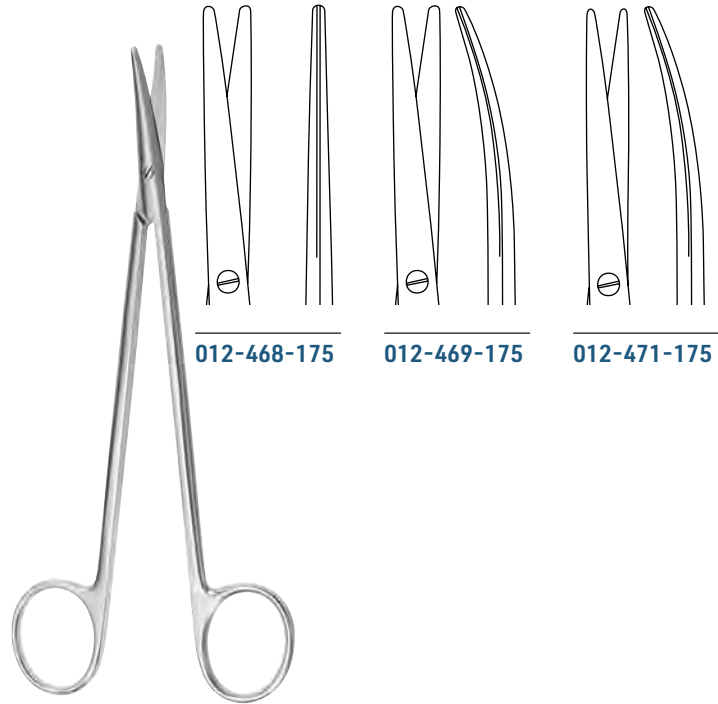

012-468-175

012-469-175

012-471-175

TOENNIS-ADSON

012-468-175 - 012-471-175 17,5 cm / 7"



OLIVECRONA

012-473-230 23,0 cm / 9"

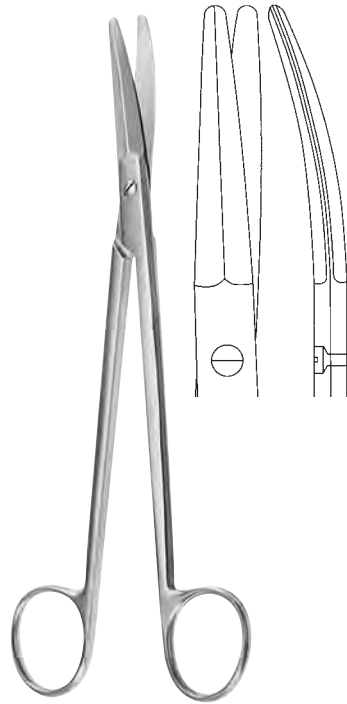

BOETTCHER

012-501-180 18,0 cm / 7"

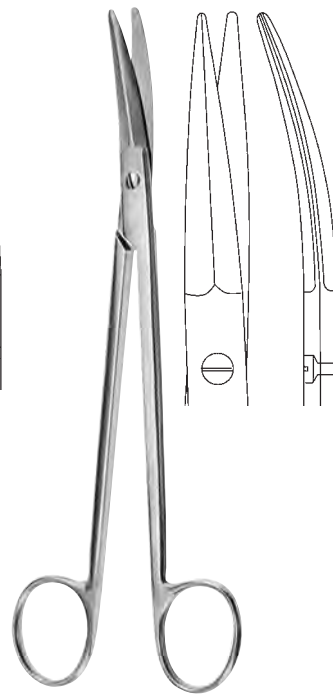

PRINCE

012-503-175 17,5 cm / 7"

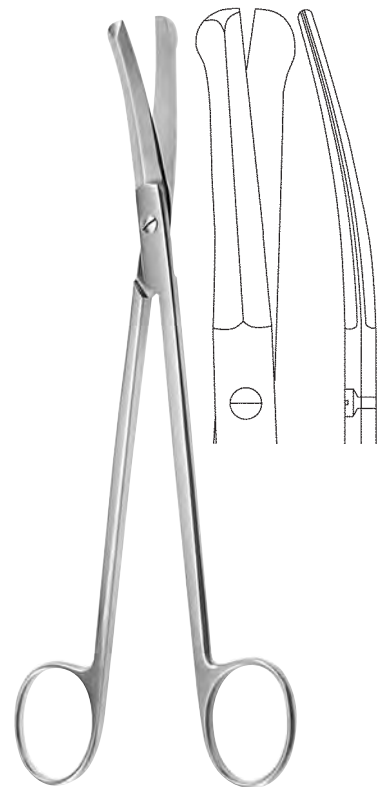

GOOD

012-505-190 19,0 cm / 7 1/2"



HEYMANN

012-507-180 18,0 cm / 7"

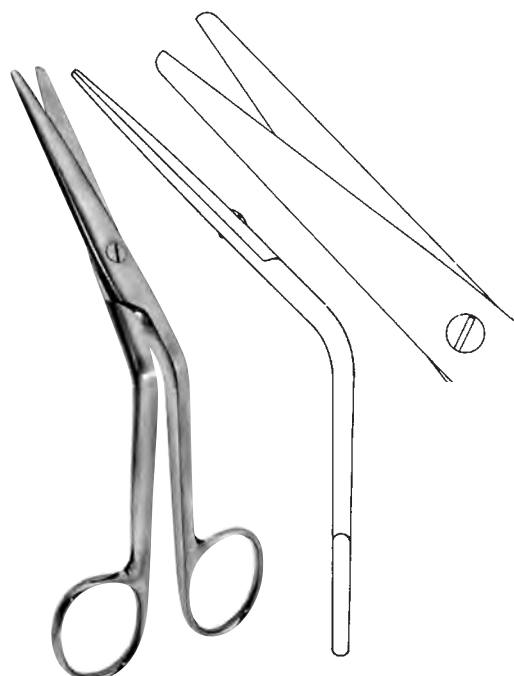

COTTLE

012-509-160 16,0 cm / 6 1/4"

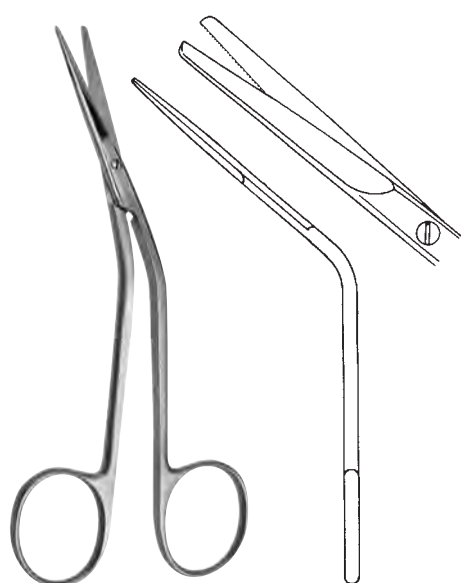

FOMON

012-511-150 15,0 cm / 6"

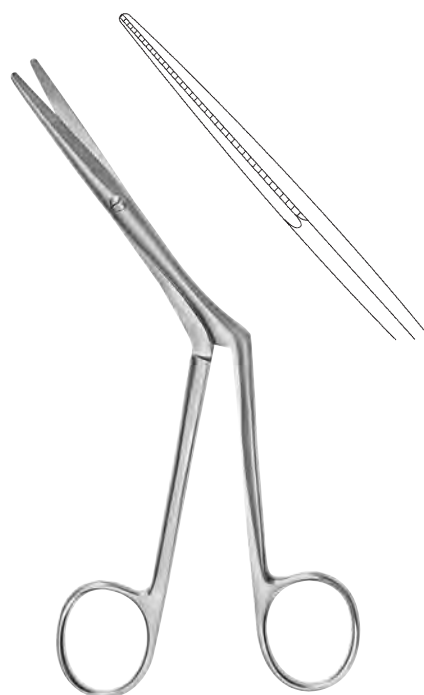

KIRSTEIN

012-513-180 18,0 cm / 7"



012

Zahnfleischscheren
Gum Scissors
Tijeras para encías
Forbici per gengiva



012-550-160



012-551-160



012-553-170

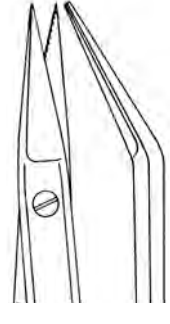

012-555-170

1 Schneide gezahnt
1 toothed blade
1 hoja dentada
1 lame dentata

KELLY

012-550-160 - 012-551-160 16,0 cm / 6 1/4"

DEAN

012-553-170 - 012-555-170 17,0 cm / 6 3/4"

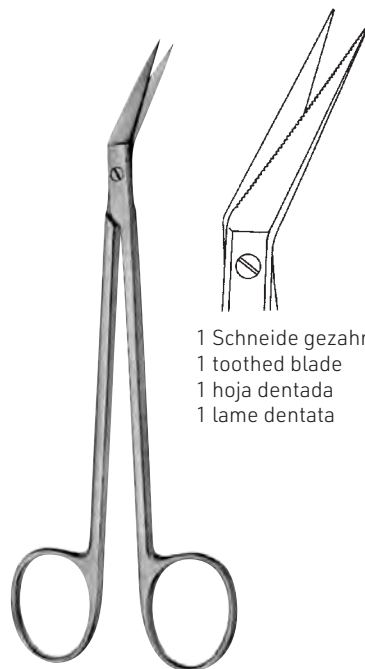

1 Schneide gezahnt
1 toothed blade
1 hoja dentada
1 lame dentata

LOCKLIN

012-557-160 16,0 cm / 6 1/4"

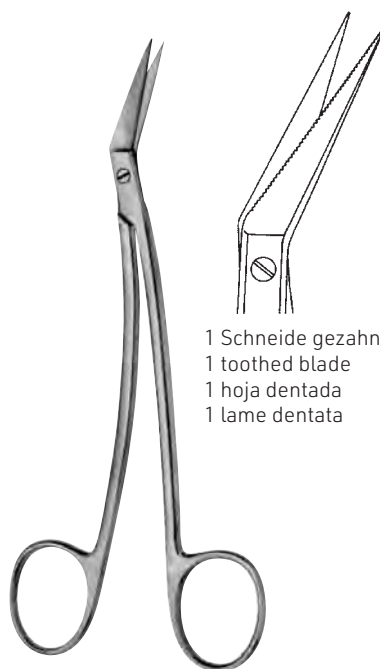

1 Schneide gezahnt
1 toothed blade
1 hoja dentada
1 lame dentata

LOCKLIN

012-559-160 16,0 cm / 6 1/4"



QUINBY

012-561-125 12,5 cm / 5"

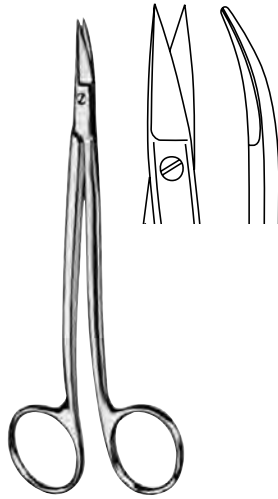

NEUMANN

012-563-125 12,5 cm / 5"

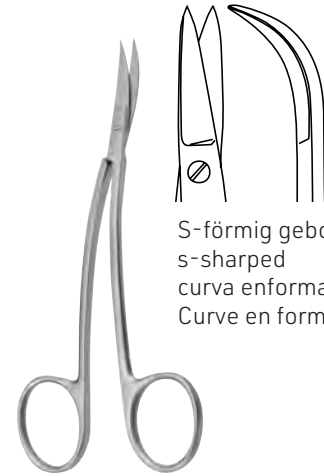

S-förmig gebogen
 s-sharped
 curva en forma S
 Curve en forma S

LA GRANGE

012-565-115 11,5 cm / 4½"

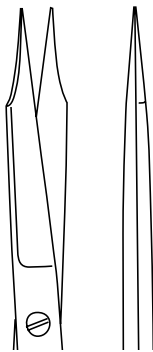

012-566-130

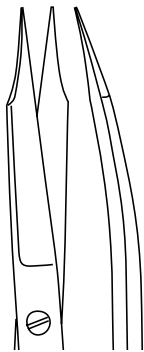

012-567-130



012-568-130

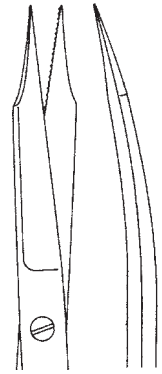

012-569-130

1 Schneide gezahnt
 1 toothed blade
 1 hoja dentada
 1 lame dentata



GOLDMANN-FOX

012-566-130 - 012-567-130 13,0 cm / 5¼"



GOLDMANN-FOX

012-568-130 - 012-569-130 13,0 cm / 5¼"



012

Drahtscheren
Wire Cutting Scissors
Cizallas corta-alambres
Forbici taglia cavo



BEEBEE

012-570-105 - 012-571-105

10,5 cm / 4¹/₄"



BEEBEE

012-572-105 - 012-573-105

10,5 cm / 4¹/₄"

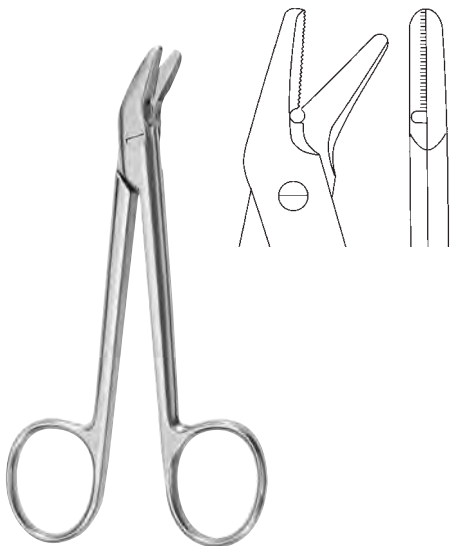

UNIVERSAL

012-575-120 12,0 cm / 4³/₄"



012-580-210 21,0 cm / 8¹/₄"



012-582-210 21,0 cm / 8¹/₄"



012-584-210 21,0 cm / 8¹/₄"



012

Ligaturscheren
Ligature Scissors
Tijeras para ligaduras
Forbici per legature



SPENCER

- 012-590-090** 9,0 cm / 3 1/2"
- 012-590-105** 11,0 cm / 4 1/4"
- 012-590-130** 13,0 cm / 5 1/8"



NORTHBENT

- 012-591-090** 9,0 cm / 3 1/2"
- 012-591-125** 12,5 cm / 5"



LITTAUER

- 012-592-140** 14,0 cm / 5 1/2"



BUCK

- 012-594-145** 14,5 cm / 5 3/4"
- 012-594-180** 18,0 cm / 7"

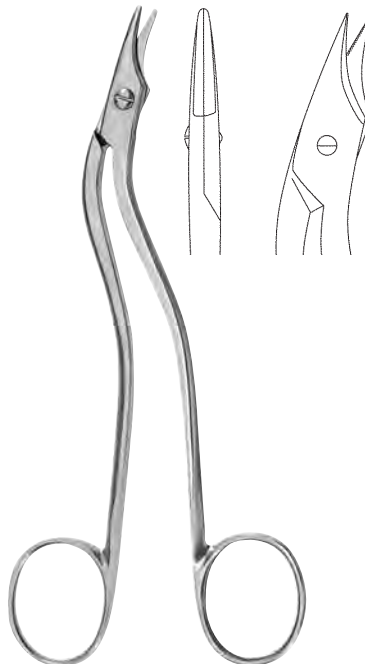

HEATH

- 012-595-160** 16,0 cm / 6 1/4"



EISELSBERG

- 012-596-120** 12,0 cm / 4 3/4"

- lange Lebensdauer
- hohe Wirtschaftlichkeit
- hervorragende Schnitthaltigkeit
- glatter weicher Schnitt
- durchgehend gehärtet
- vergoldete Ringe zur schnellen Identifikation

-
- long lasting performance
 - economical
 - excellent cutting action
 - smooth cutting
 - fully tempered
 - goldplated rings for easy identification

-
- larga duración
 - gran economía
 - corte de máxima agudeza
 - suave filo
 - completamente templado
 - anillos dorados para su identificación

-
- prestazioni di lunga durata
 - risparmi sul costo
 - eccellente accuratezza del taglio
 - taglio liscio
 - completamente temperato
 - anelli bagnati in oro permettono una più semplice identificazione





012

Chirurgische Scheren mit Hartmetallschneiden
Surgical Scissors with tungsten carbide edges
Tijeras para cirugía con filos de carburo tungsteno
Forbici per chirurgia con lame in carburo di tungsteno



STANDARD

012-700-145 14,5 cm / 5³/₄"



STANDARD

012-701-145 14,5 cm / 5³/₄"

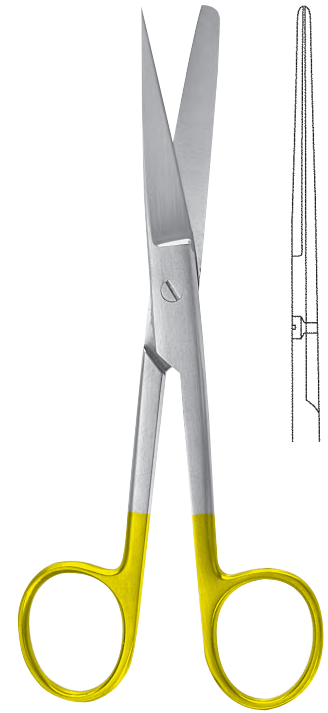

STANDARD

012-702-145 14,5 cm / 5³/₄"



STANDARD

012-703-145 14,5 cm / 5³/₄"



STANDARD

012-704-145 14,5 cm / 5³/₄"

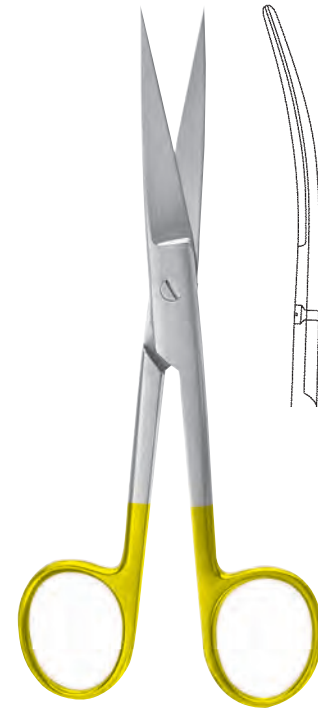

STANDARD

012-705-145 14,5 cm / 5³/₄"

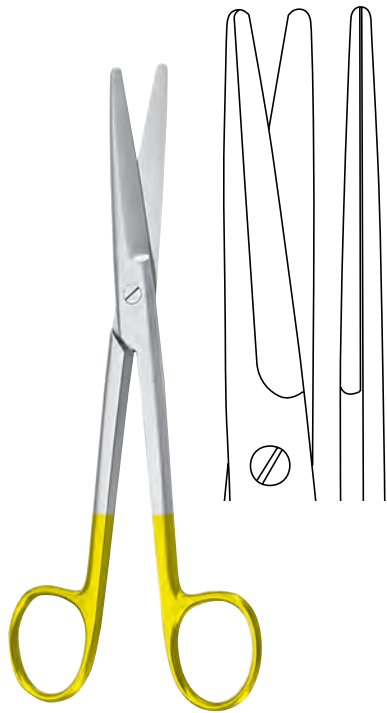

MAYO

- 012-710-145** 14,5 cm / 5³/₄"
- 012-710-170** 17,0 cm / 6³/₄"
- 012-710-230** 23,0 cm / 9"

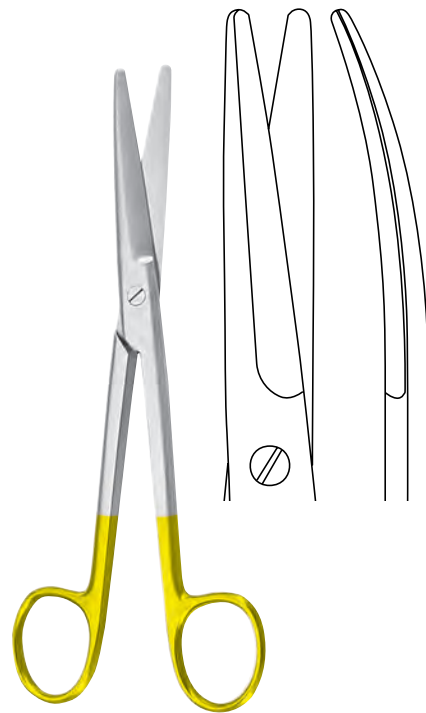

MAYO

- 012-711-145** 14,5 cm / 5³/₄"
- 012-711-170** 17,0 cm / 6³/₄"
- 012-711-230** 23,0 cm / 9"

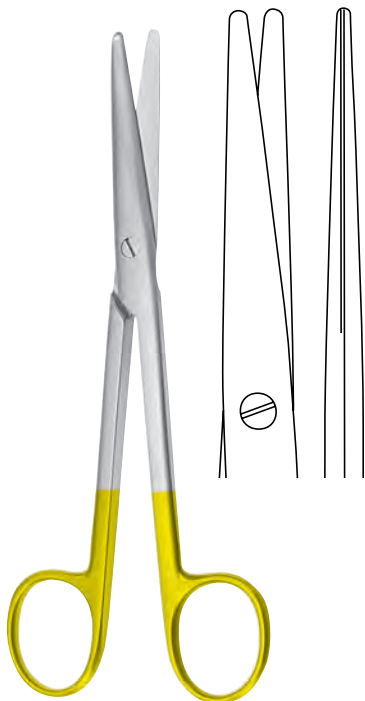

MAYO-STILLE

- 012-714-150** 15,0 cm / 6"
- 012-714-170** 17,0 cm / 6³/₄"

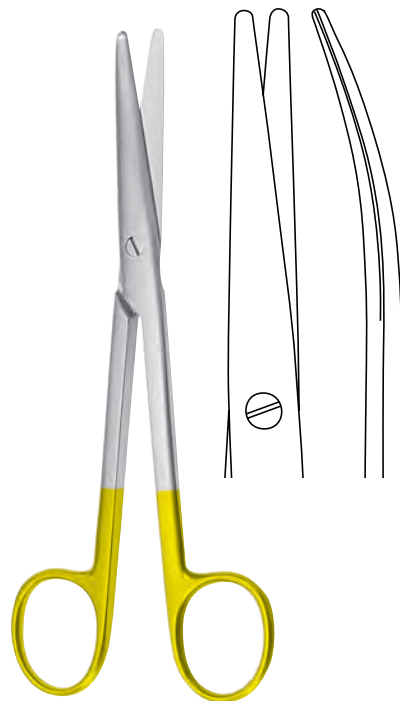

MAYO-STILLE

- 012-715-150** 15,0 cm / 6"
- 012-715-170** 17,0 cm / 6³/₄"



MAYO-LEXER

- 012-720-160 - 012-721-160** 16,0 cm / 6¹/₄"

012-720-160

012-721-160



012

Chirurgische Scheren mit Hartmetallschneiden
 Surgical Scissors with tungsten carbide edges
 Tijeras para cirugía con filos de carburo tungsteno
 Forbici per chirurgia con lame in carburo di tungsteno



LEXER

012-722-160 16,0 cm / 6 1/4"
012-722-210 21,0 cm / 8 1/4"

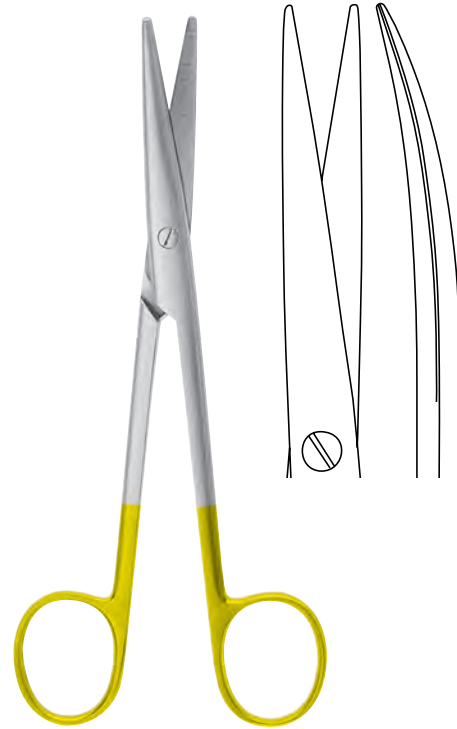

LEXER

012-723-160 16,0 cm / 6 1/4"
012-723-210 21,0 cm / 8 1/4"



012-730-115

012-731-115

METZENBAUM

012-730-115 - 012-731-115 11,5 cm / 4 1/2"



012-730-145

012-731-145

METZENBAUM

012-730-145 - 012-731-145 14,5 cm / 5 1/2"

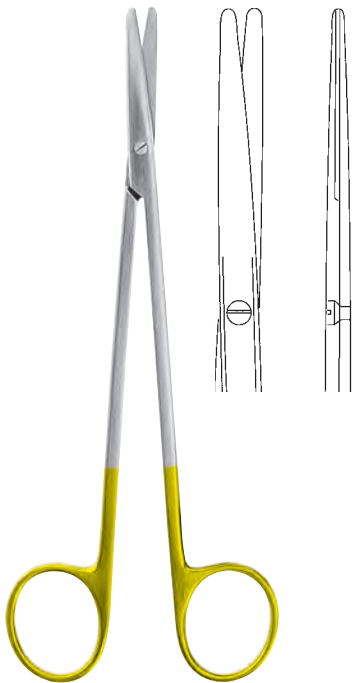

METZENBAUM

012-730-180	18,0 cm / 7"
012-730-200	20,0 cm / 8"
012-730-230	23,0 cm / 9"
012-730-250	25,0 cm / 10"
012-730-280	28,0 cm / 11"
012-730-300	30,0 cm / 12"

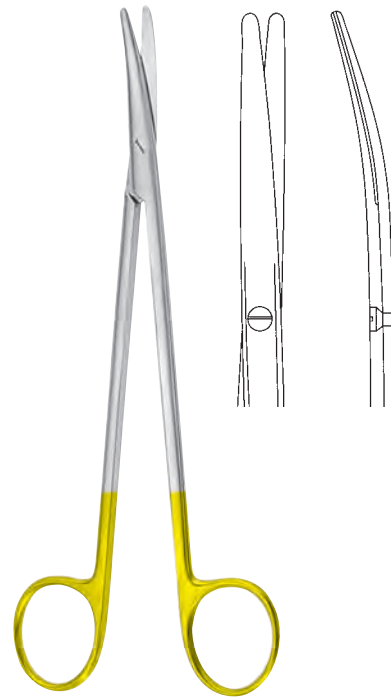

METZENBAUM

012-731-180	18,0 cm / 7"
012-731-200	20,0 cm / 8"
012-731-230	23,0 cm / 9"
012-731-250	25,0 cm / 10"
012-731-280	28,0 cm / 11"
012-731-300	30,0 cm / 12"



012-740-145

012-741-145

METZENBAUM-FINO

012-740-145 - 012-741-145	14,5 cm / 5 1/2"
----------------------------------	------------------



012-742-145

012-743-145

METZENBAUM-FINO

012-742-145 - 012-743-145	14,5 cm / 5 1/2"
----------------------------------	------------------



012

Präparierscheren mit Hartmetallschneiden
 Dissecting Scissors with tungsten carbide edges
 Tijeras para disección con filos de carburo tungsteno
 Forbici per dissezione con lame in carburo di tungsteno

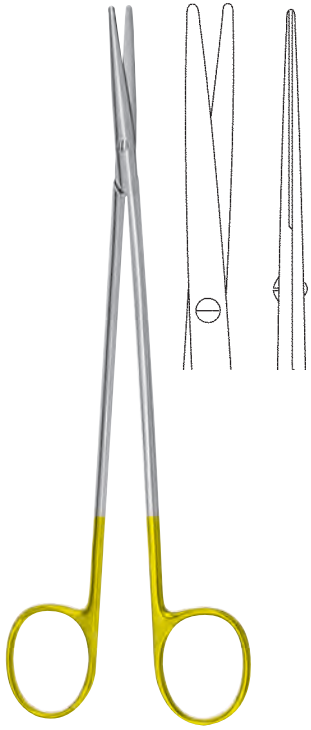

METZENBAUM-FINO

- 012-740-180** 18,0 cm / 7"
- 012-740-200** 20,0 cm / 8"
- 012-740-230** 23,0 cm / 9"
- 012-740-250** 25,0 cm / 10"
- 012-740-280** 28,0 cm / 11"

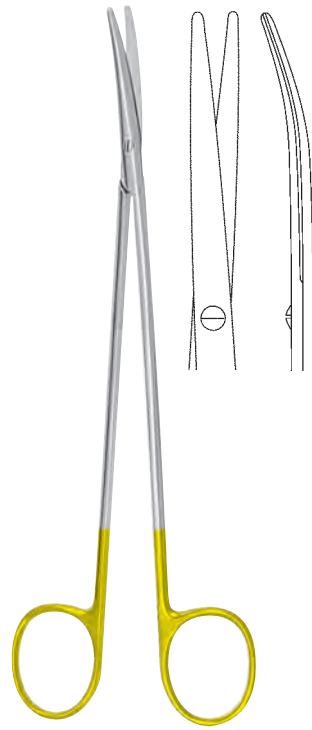

METZENBAUM-FINO

- 012-741-180** 18,0 cm / 7"
- 012-741-200** 20,0 cm / 8"
- 012-741-230** 23,0 cm / 9"
- 012-741-250** 25,0 cm / 10"
- 012-741-280** 28,0 cm / 11"

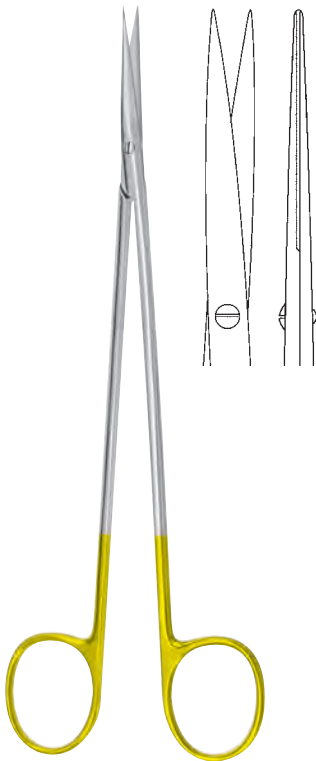

METZENBAUM-FINO

- 012-742-180** 18,0 cm / 7"
- 012-742-200** 20,0 cm / 8"
- 012-742-230** 23,0 cm / 9"

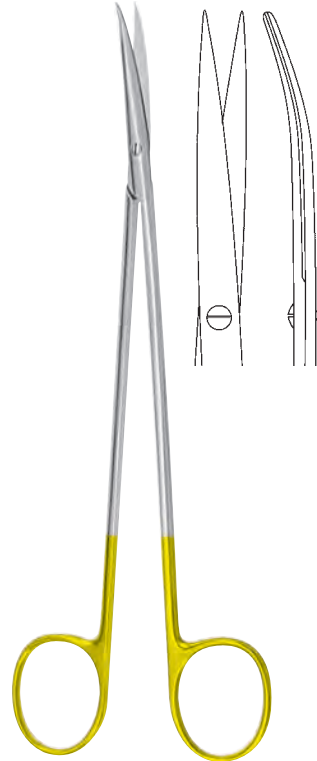

METZENBAUM-FINO

- 012-743-180** 18,0 cm / 7"
- 012-743-200** 20,0 cm / 8"
- 012-743-230** 23,0 cm / 9"

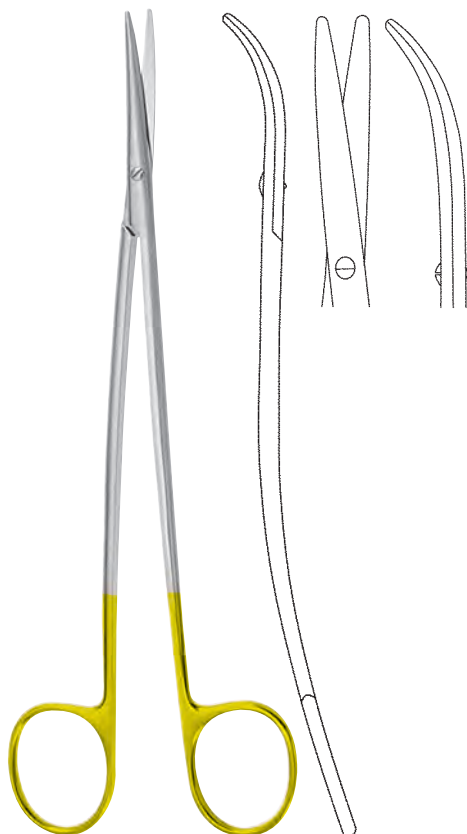

METZENBAUM-FINO S

012-745-180	18,0 cm / 7"
012-745-200	20,0 cm / 8"
012-745-230	23,0 cm / 9"

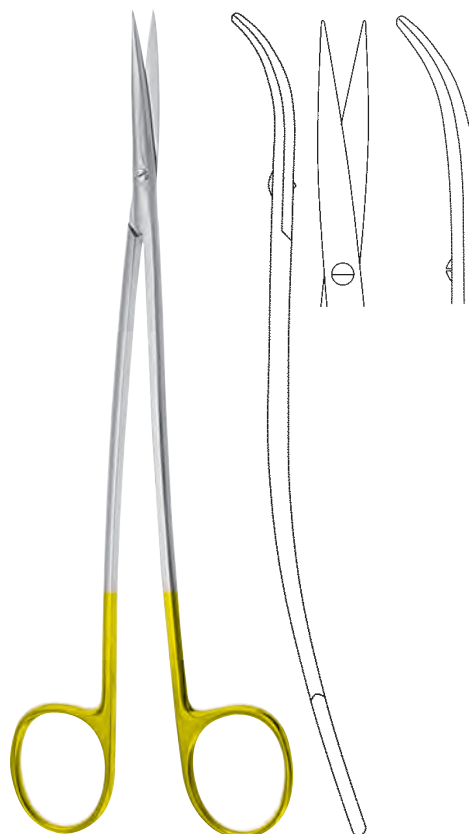

METZENBAUM-FINO S

012-747-180	18,0 cm / 7"
012-747-200	20,0 cm / 8"
012-747-230	23,0 cm / 9"

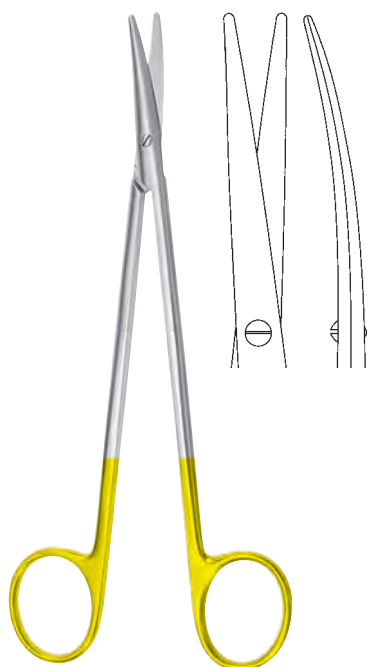

TOENNIS-ADSON

012-749-175	17,5 cm / 7"
--------------------	--------------



012

Gefäßscheren mit Hartmetallschneiden
Vascular Scissors with tungsten carbide edges
Tijeras vasculares con filos de carburo tungsteno
Forbici vascolari con lame in carburo di tungsteno



25°

012-761-025

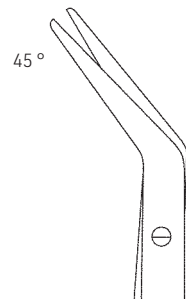

45°

012-761-045

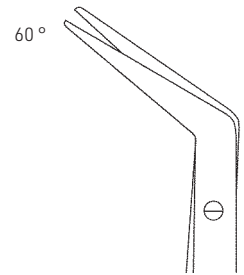

60°

012-761-060

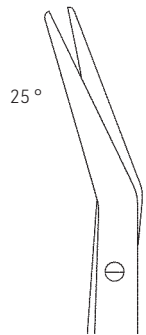

25°

012-763-025

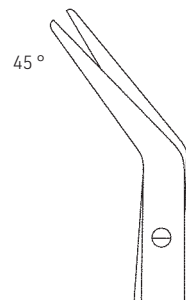

45°

012-763-045

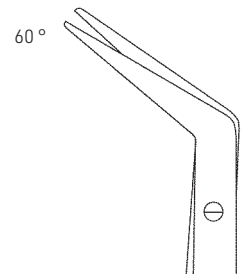

60°

012-763-060

DE BAKEY

012-761-025 - 012-761-060 18,0 cm / 7"
012-763-025 - 012-763-060 23,0 cm / 9"

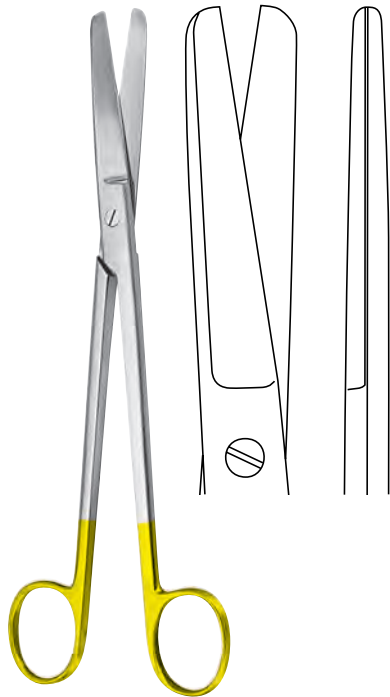

SIMS

012-770-200 20,0 cm / 8"
012-770-230 23,0 cm / 9"

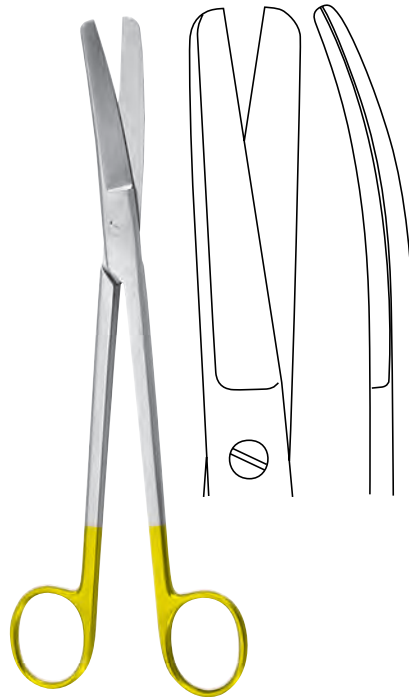

SIMS

012-771-200 20,0 cm / 8"
012-771-230 23,0 cm / 9"

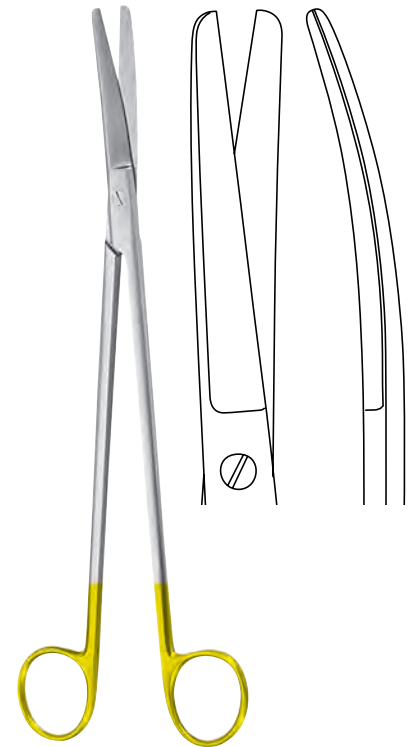

WERTHEIM

012-773-225 22,5 cm / 8³/₄"

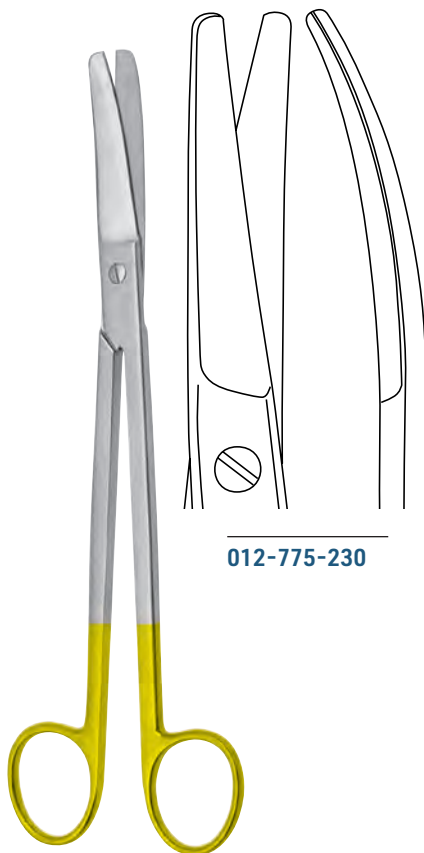

012-775-230

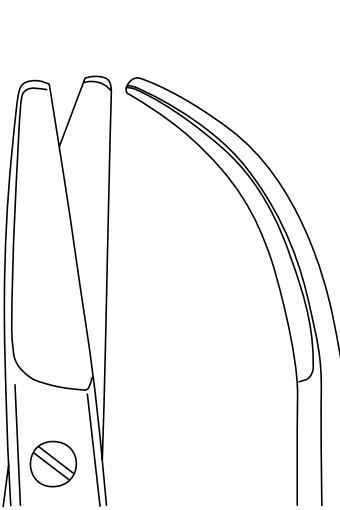

012-775-225

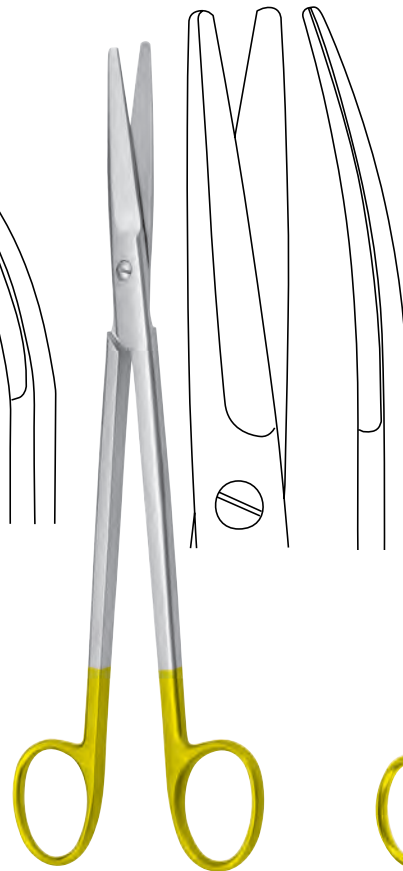

MAYO-HARRINGTON

012-777-280 28,0 cm / 11"



gezahnt
toothed
dentada
dentate

PARAMETRIUM

012-775-225 22,5 cm / 8³/₄"
012-775-230 23,0 cm / 9"

012-778-195 19,5 cm / 7³/₄"



012

Scheren mit Hartmetallschneiden
Scissors with tungsten carbide edges
Tijeras con filos de carburo tungsteno
Forbici con lame in carburo di tungsteno

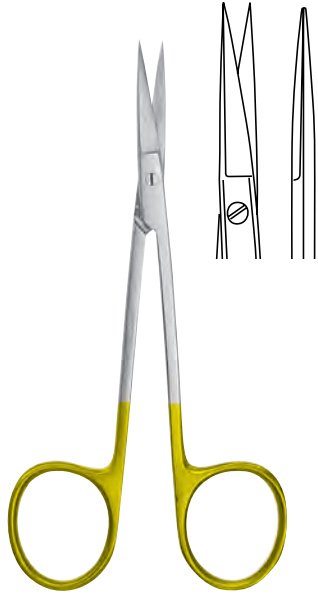

IRIS
012-780-115 11,5 cm / 4 1/2"



IRIS
012-781-115 11,5 cm / 4 1/2"

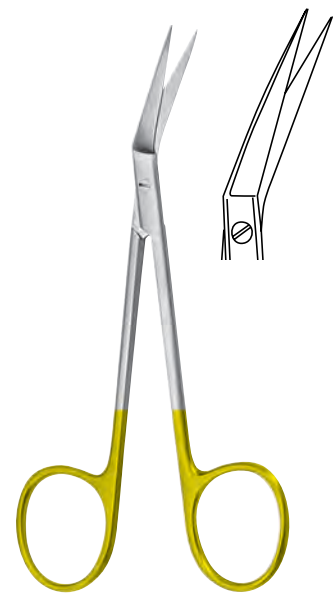

IRIS
012-783-115 11,5 cm / 4 1/2"



012-784-140

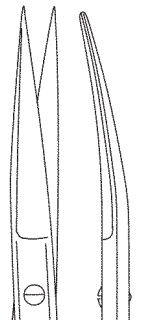

012-785-140

JOSEPH
012-784-140 - 012-785-140 14,0 cm, 5 1/2"

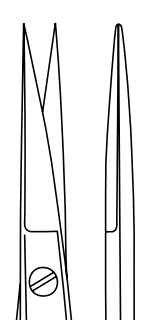

012-786-160

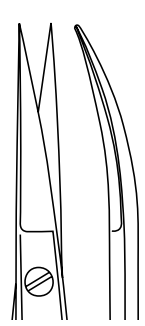

012-787-160



KELLY
012-786-160 - 012-787-160 16,0 cm / 6 1/4"

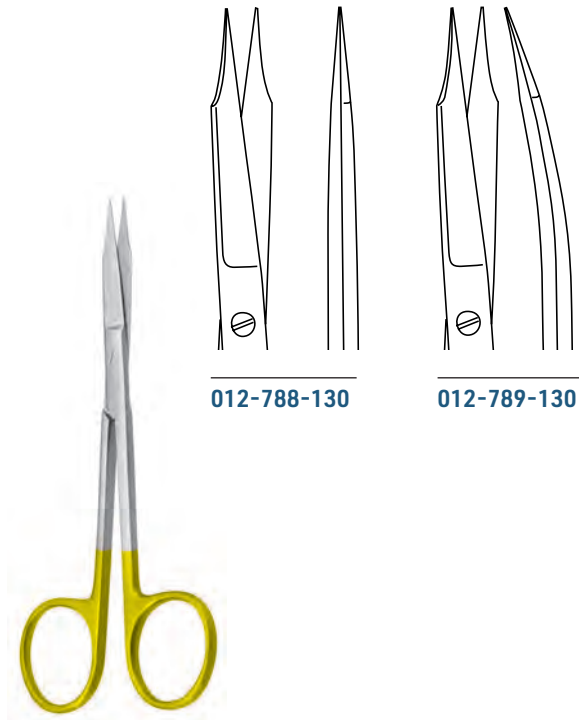

GOLDMANN-FOX

012-788-130 - 012-789-130 13,0 cm / 5 1/8"

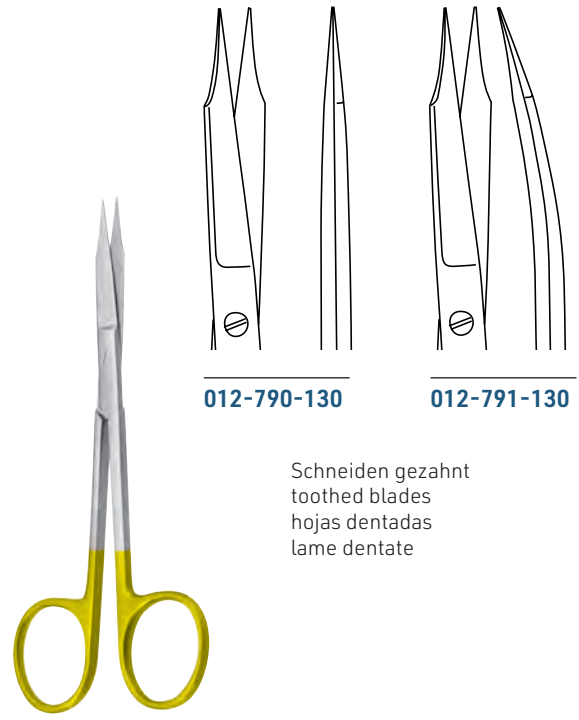

Schneiden gezahnt
 toothed blades
 hojas dentadas
 lame dentate

GOLDMANN-FOX

012-790-130 - 012-791-130 13,0 cm / 5 1/8"

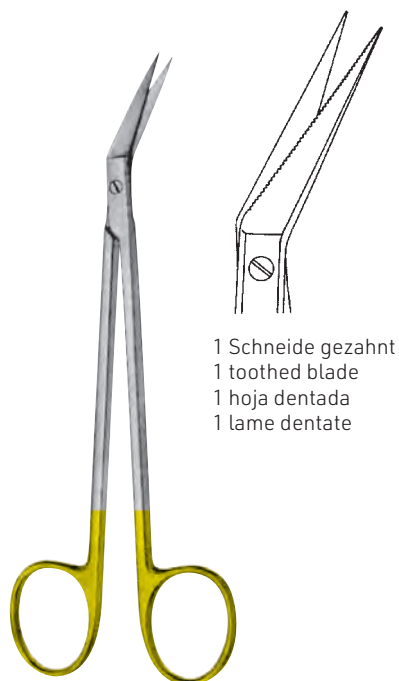

1 Schneide gezahnt
 1 toothed blade
 1 hoja dentada
 1 lame dentate

LOCKLIN

012-793-160 16,0 cm / 6 1/4"

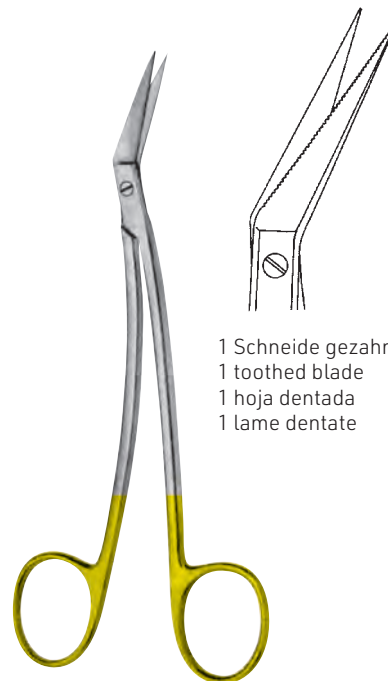

1 Schneide gezahnt
 1 toothed blade
 1 hoja dentada
 1 lame dentate

LOCKLIN

012-795-160 16,0 cm / 6 1/4"



012

Scheren mit Hartmetallschneiden
Scissors with tungsten carbide edges
Tijeras con filos de carburo tungsteno
Forbici con lame in carburo di tungsteno



RAGNELL (KILLNER)

012-797-120 12,0 cm / 4³/₄"

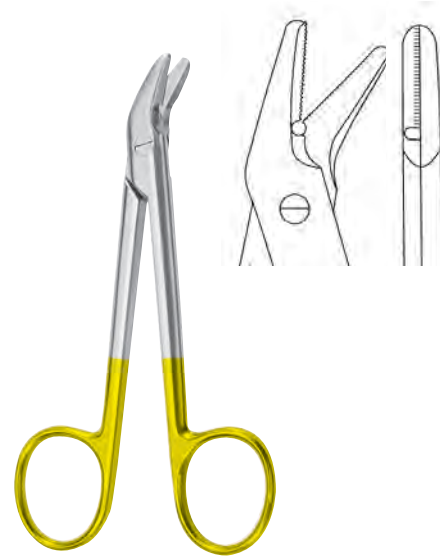

UNIVERSAL

012-799-120 12,0 cm / 4³/₄"

Super Cut

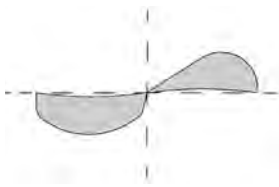

Standard

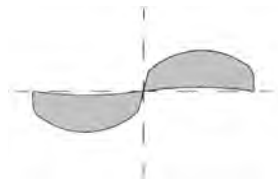

- Messerschiff für optimalen Schnitt
- 1 gezahntes Blatt verhindert das Herausgleiten des Gewebes
- schwarze Ringe

-
- Knife blade sharpness for optimum cutting
 - 1 serrated blade prevents tissue from slipping out
 - black-plated rings

-
- Filo tipo cuchillo para un corte óptimo
 - 1 hoja dentada impide el deslizamiento del tejido
 - anillos negros

-
- affilatura speciale per un ottimo taglio
 - Lama a denti micro
 - anelli neri





012

Super-Cut Scheren
Super-Cut Scissors
Tijeras Super-Cut
Forbici Super-Cut



STANDARD

012-850-145 14,5 cm / 5³/₄"



STANDARD

012-851-145 14,5 cm / 5³/₄"

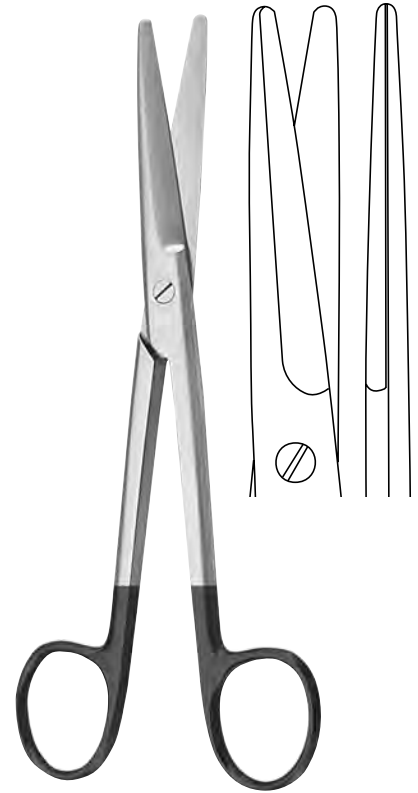

MAYO

012-852-145 14,5 cm / 5³/₄"
012-852-170 17,0 cm / 6³/₄"
012-852-230 23,0 cm / 9"

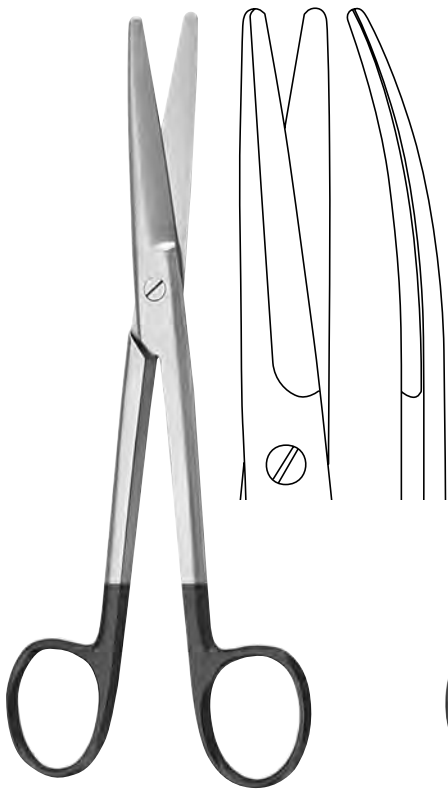

MAYO

012-853-145 14,5 cm / 5³/₄"
012-853-170 17,0 cm / 6³/₄"
012-853-230 23,0 cm / 9"

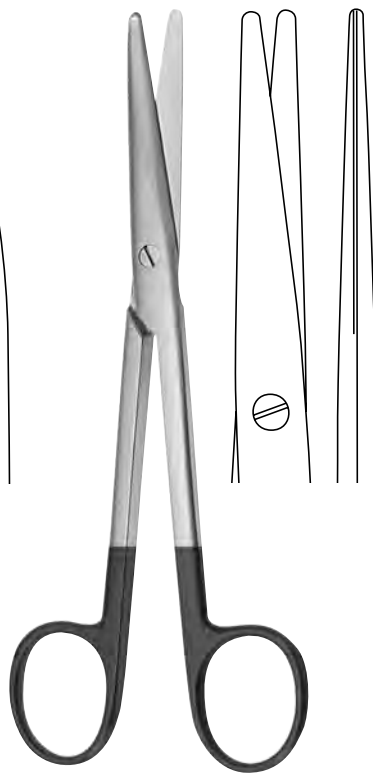

MAYO-STILLE

012-854-150 15,0 cm / 6"
012-854-170 17,0 cm / 6³/₄"

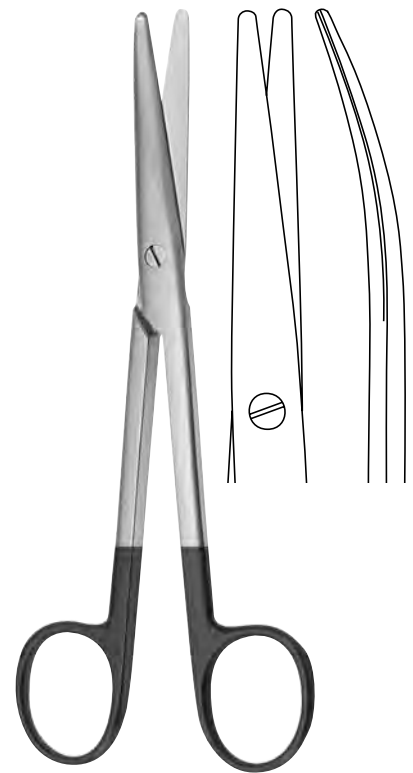

MAYO-STILLE

012-855-150 15,0 cm / 6"
012-855-170 17,0 cm / 6³/₄"



012-860-115

012-861-115

METZENBAUM

012-860-115 - 012-861-115 11,5 cm / 4 1/2"



012-860-145

012-861-145

METZENBAUM

012-860-145 - 012-861-145 14,5 cm / 5 1/2"

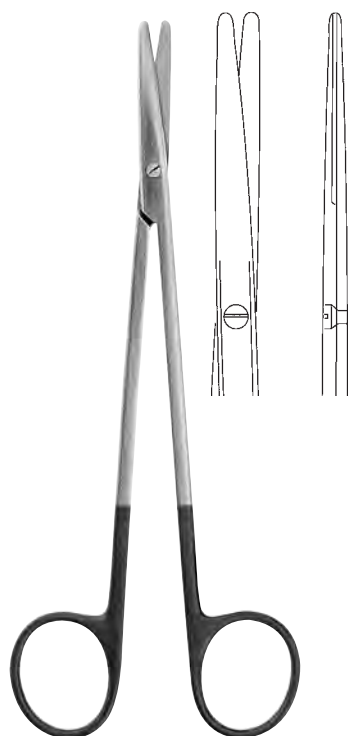

METZENBAUM-NELSON

012-860-180 18,0 cm / 7"

012-860-200 20,0 cm / 8"

012-860-230 23,0 cm / 9"



METZENBAUM-NELSON

012-861-180 18,0 cm / 7"

012-861-200 20,0 cm / 8"

012-861-230 23,0 cm / 9"



012

Super-Cut Scheren
Super-Cut Scissors
Tijeras Super-Cut
Forbici Super-Cut



012-864-115

012-865-115

STRABISMUS

012-864-115 - 012-865-115 11,5 cm / 4 1/2"

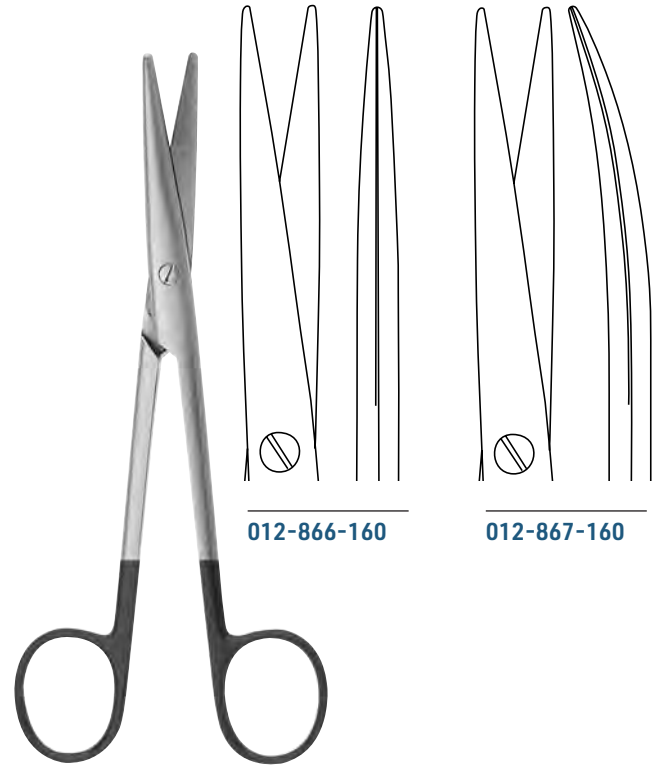

012-866-160

012-867-160

LEXER

012-866-160 - 012-867-160 16,0 cm / 6 1/4"



012-870-145

012-871-145

METZENBAUM-FINO

012-870-145 - 012-871-145 14,5 cm / 5 1/2"

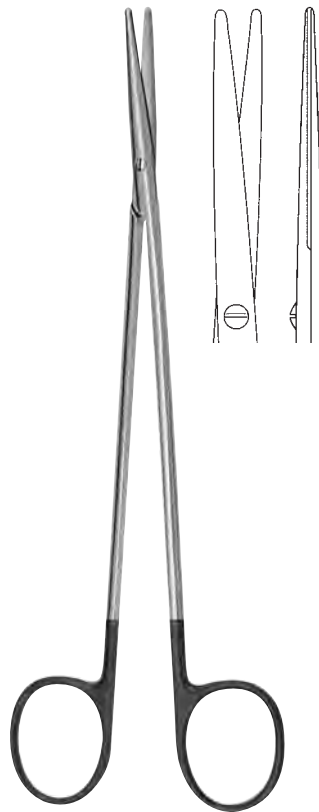

METZENBAUM-FINO

012-870-180 18,0 cm / 7"
012-870-200 20,0 cm / 8"
012-870-230 23,0 cm / 9"

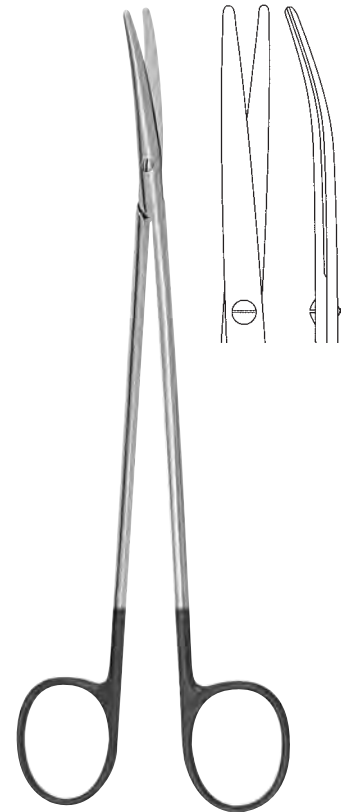

METZENBAUM-FINO

012-871-180 18,0 cm / 7"
012-871-200 20,0 cm / 8"
012-871-230 23,0 cm / 9"

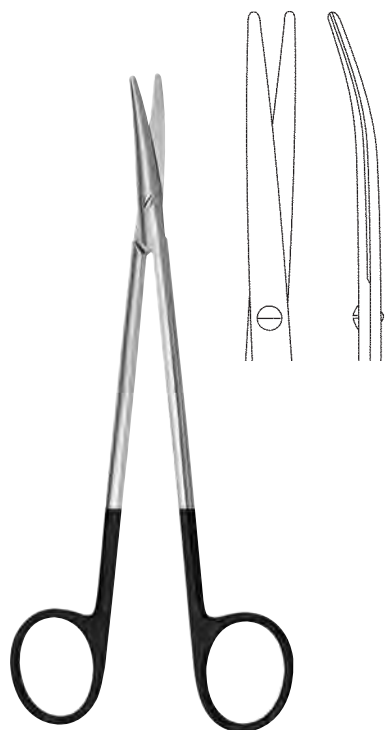

TOENNIS-ADSON

012-873-175 17,5 cm / 7"

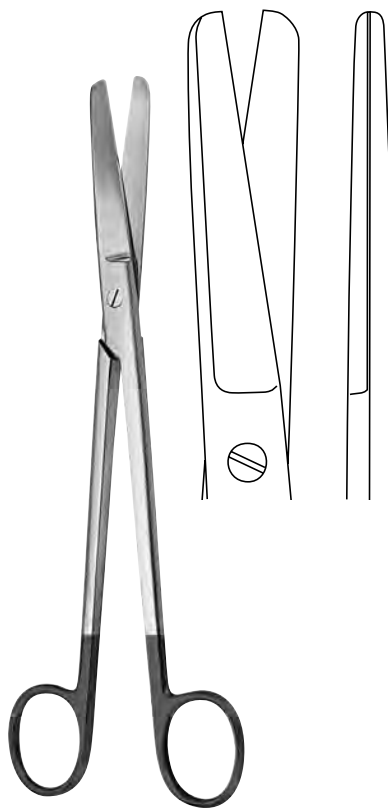

SIMS

012-880-200 20,0 cm / 8"

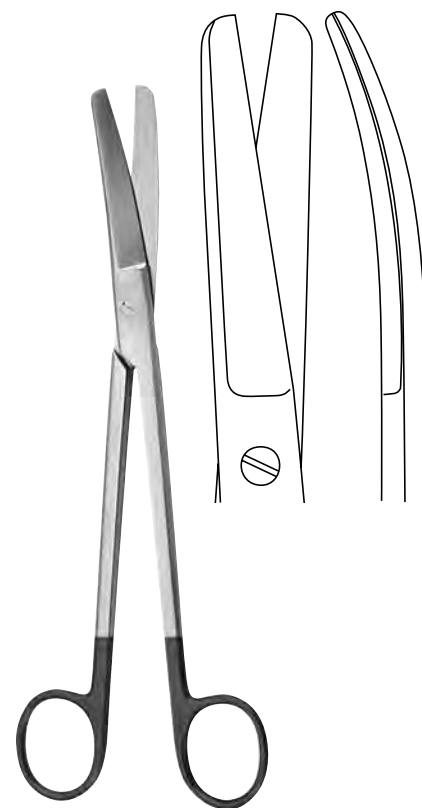

SIMS

012-881-200 20,0 cm / 8"

012-881-230 23,0 cm / 9"



SIEBOLD

012-883-240 24,0 cm / 9 1/2"



WALDMANN

012-885-180 18,0 cm / 7"



Episiotomiescheren
 Episiotomy scissors
 Tijeras para episiotomía
 Forbici per episiotomia

012-887-200 20,0 cm / 8"



012

Super-Cut Scheren
Super-Cut Scissors
Tijeras Super-Cut
Forbici Super-Cut

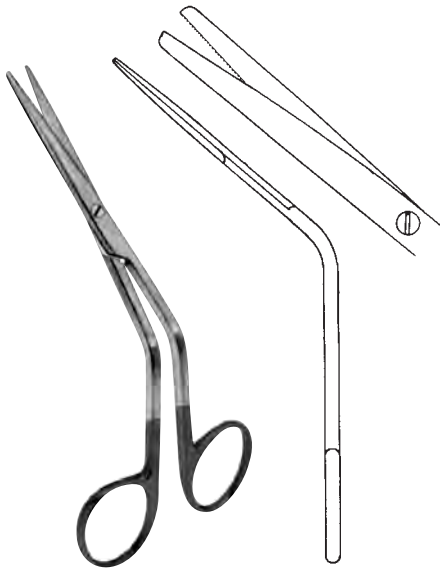

FOMON

012-891-135 13,5 cm, 5¹/₄"

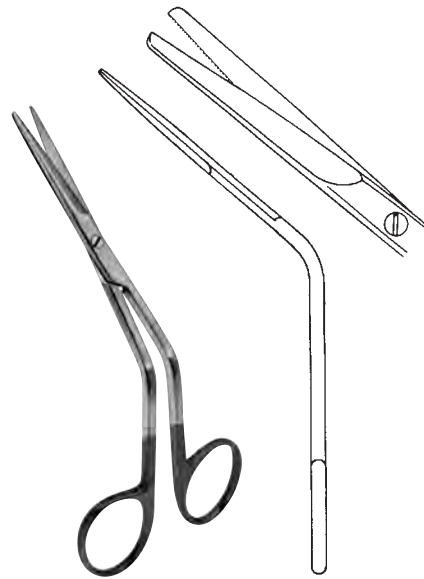

FOMON

012-893-145 14,5 cm, 5³/₄"

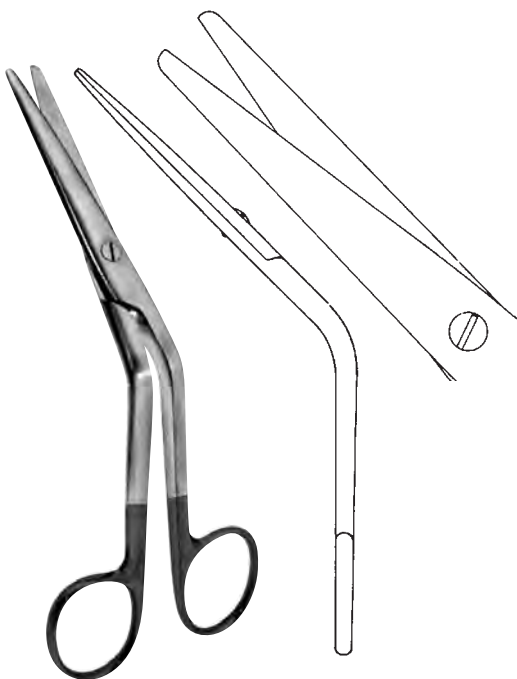

COTTLE

012-895-160 16,0 cm / 6¹/₄"



HEYMANN

012-897-180 18,0 cm / 7"

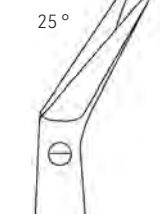
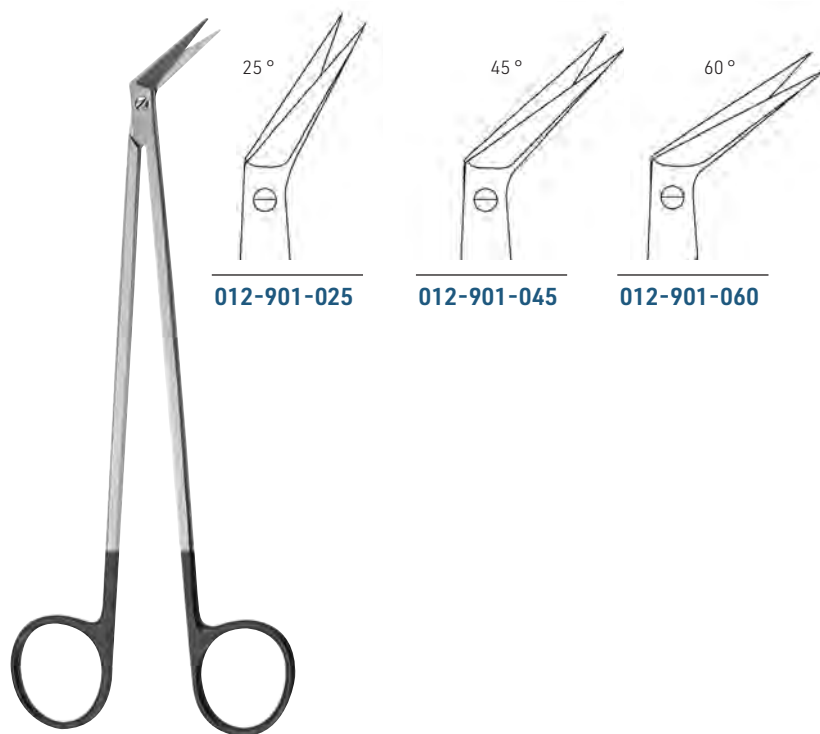

012-901-025

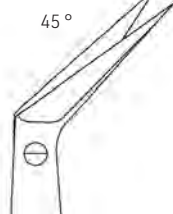

012-901-045

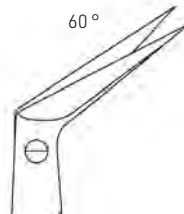

012-901-060

POTTS-SMITH

012-901-025 - 012-901-060 19,0 cm / 7 1/2"

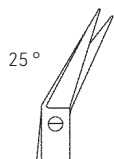
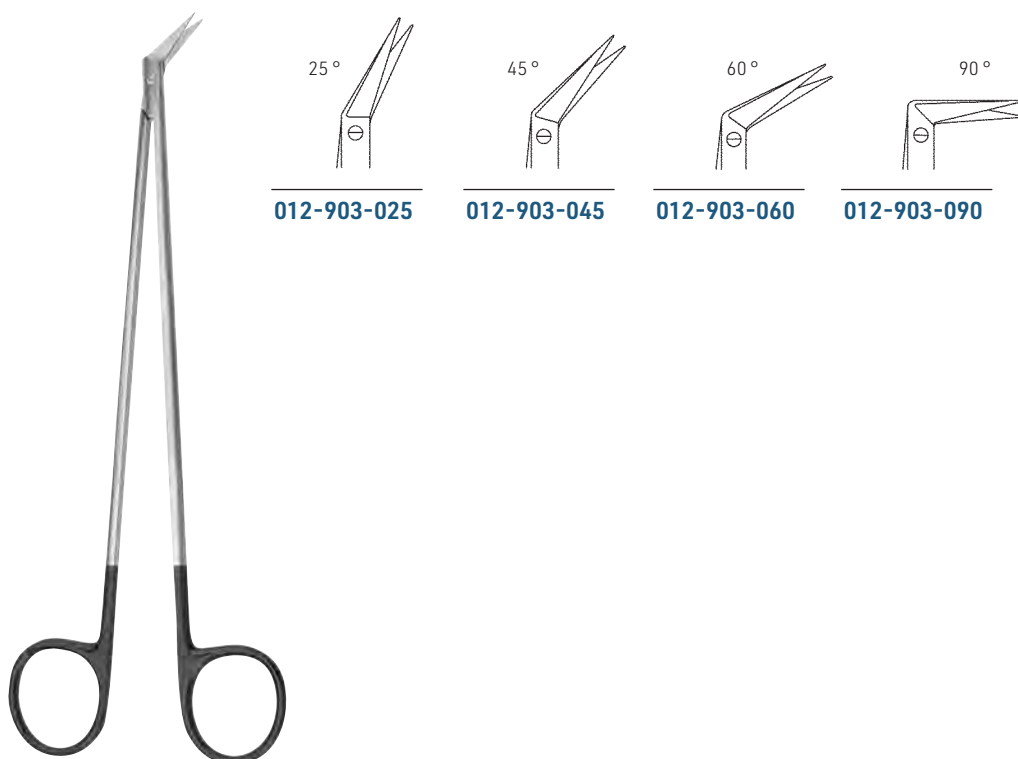

012-903-025

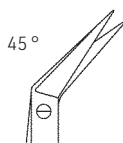

012-903-045

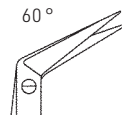

012-903-060

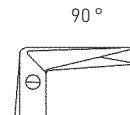

012-903-090

DIETRICH

012-903-025 - 012-903-090 19,0 cm / 7 1/2"



012

Super-Cut Scheren
Super-Cut Scissors
Tijeras Super-Cut
Forbici Super-Cut

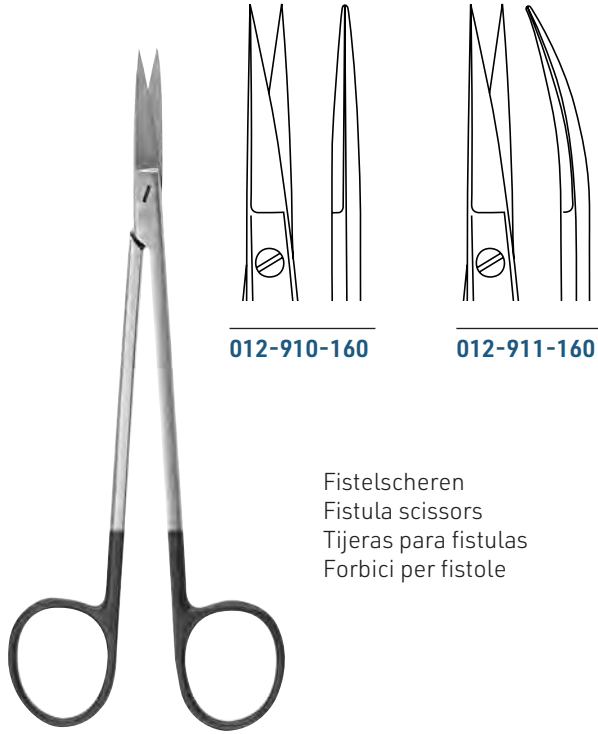

012-910-160

012-911-160

Fistelscheren
Fistula scissors
Tijeras para fistulas
Forbici per fistole

KELLY

012-910-160 - 012-911-160 16,0 cm / 6 1/4"



012-912-140

012-913-140

JOSEPH

012-912-140 - 012-913-140 14,0 cm, 5 1/2"

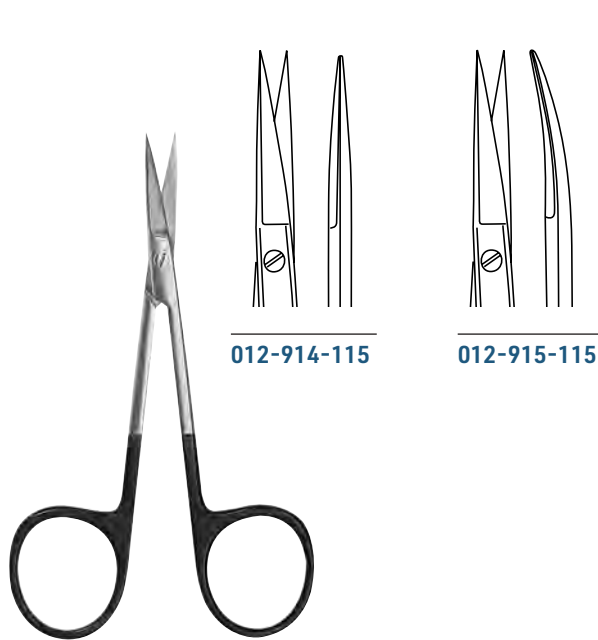

012-914-115

012-915-115

IRIS

012-914-115 - 012-915-115 11,5 cm / 4 1/2"



012-916-120

012-917-120

WAGNER

012-916-120 - 012-917-120 12,0 cm / 4 3/4"



012-920-115

012-921-115

STEVENS

012-920-115 - 012-921-115 11,5 cm / 4 1/2"



012-922-130

012-923-130

GOLDMANN-FOX

012-922-130 - 012-923-130 13,0 cm / 5 1/8"

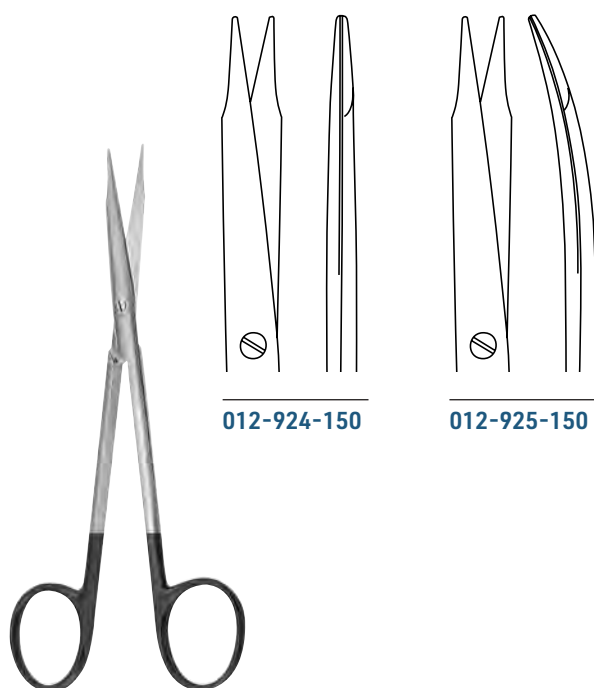

012-924-150

012-925-150

REYNOLDS

012-924-150 - 012-925-150 15,0 cm / 6"

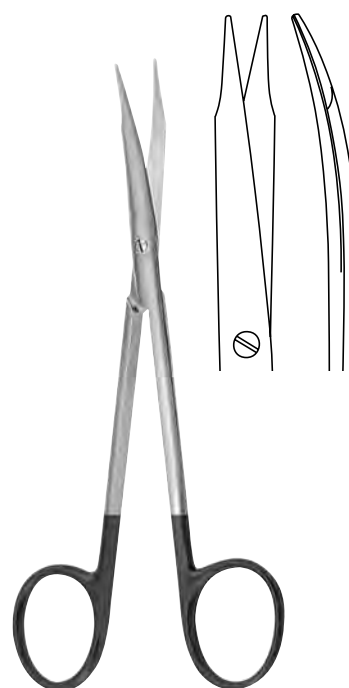

REYNOLDS

012-925-175 17,5 cm / 7"



012

Super-Cut Scheren
Super-Cut Scissors
Tijeras Super-Cut
Forbici Super-Cut

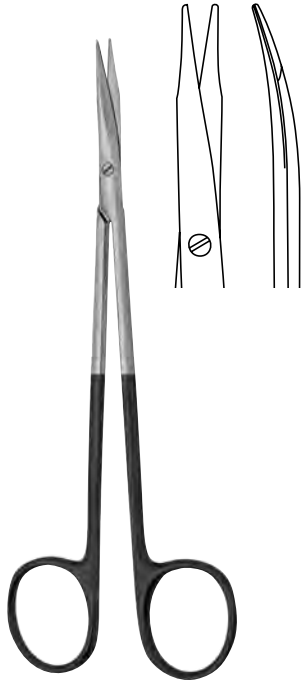

JAMESON

012-927-150 15,0 cm / 6"



PAR-TYPE

012-930-120 - 012-931-120 12,0 cm / 4³/₄"

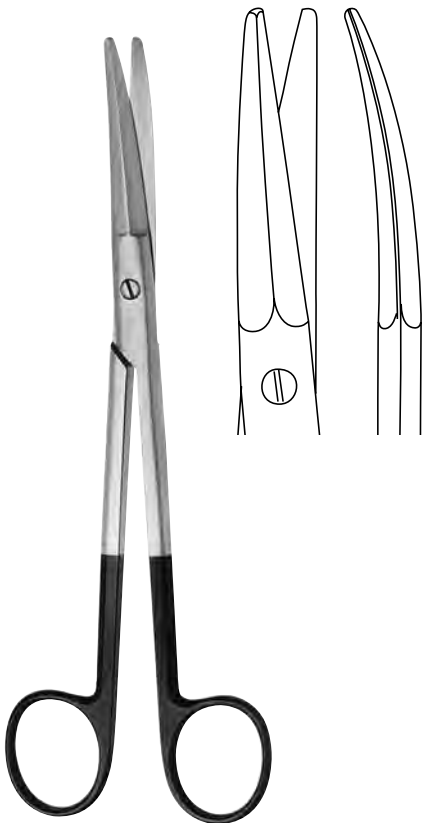

KAYE FACE LIFT

012-933-150 15,0 cm / 6"
012-933-190 19,0 cm / 7¹/₂"

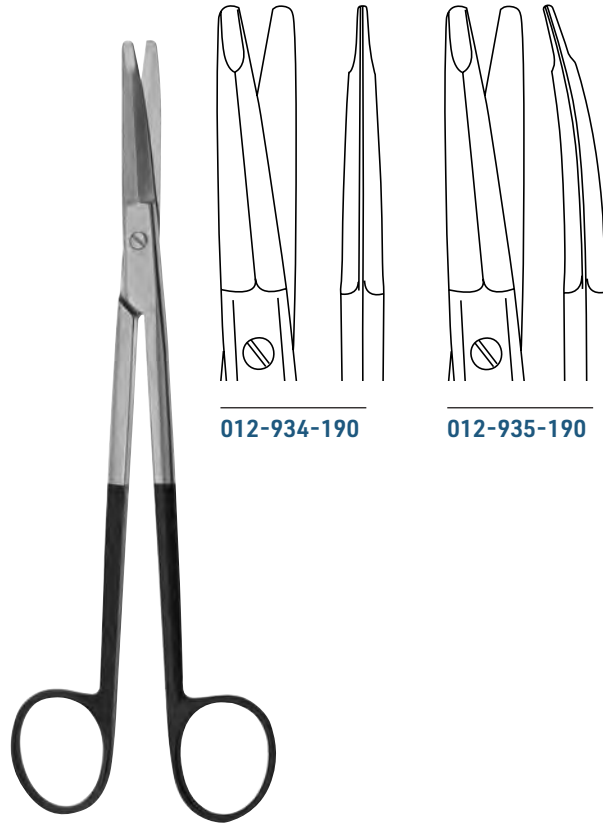

GORNEY

012-934-190 - 012-935-190 19,0 cm / 7¹/₂"

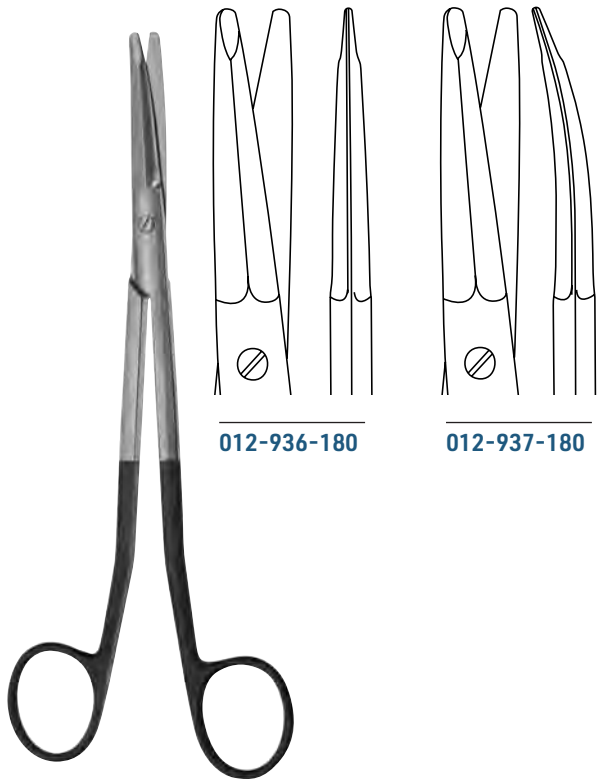

012-936-180

012-937-180

FREEMANN-KAYE

012-936-180 - 012-937-180 18,0 cm / 7"

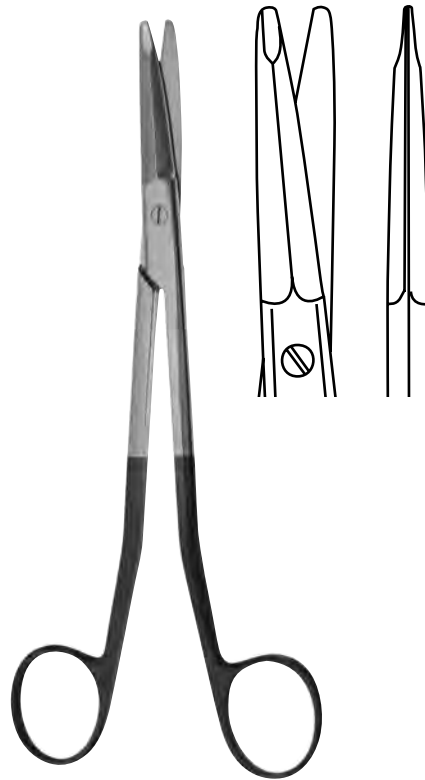

FREEMANN-GORNEY

012-938-190 19,0 cm / 7 1/2"
 012-938-230 23,0 cm / 9"

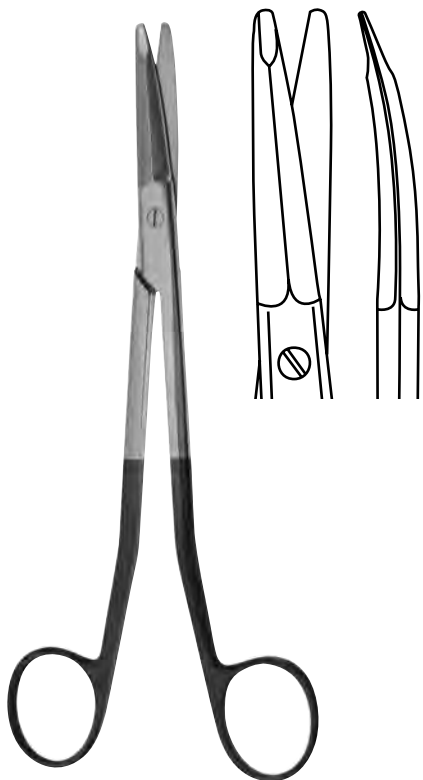

FREEMANN-GORNEY

012-939-190 19,0 cm / 7 1/2"
 012-939-230 23,0 cm / 9"



LISTER

012-951-140 14,0 cm / 5 1/2"
 012-951-180 18,0 cm / 7"
 012-951-200 20,0 cm / 8"



012



013

Pinzetten - anatomische,
chirurgische, Mikro
Forceps - anatomics,
surgicals, Micro
Pinzas - anatómicas,
quirurgicas, Micro
Pinze - anatomiche, chi-
rurgici, Micro



013

Anatomische Pinzetten
 Dissecting Forceps
 Pinzas de disección
 Pinze anatomiche per dissezione



schmal
 narrow
 estrecha
 stretti



STANDARD

013-100-105	10,5 cm / 4 ¹ / ₈ "
013-100-115	11,5 cm / 4 ¹ / ₂ "
013-100-130	13,0 cm / 5"
013-100-145	14,5 cm / 5 ³ / ₄ "
013-100-160	16,0 cm / 6 ¹ / ₄ "
013-100-180	18,0 cm / 7"
013-100-200	20,0 cm / 8"
013-100-250	25,0 cm / 10"
013-100-300	30,0 cm / 12"

STANDARD

013-110-115	11,5 cm / 4 ¹ / ₂ "
013-110-130	13,0 cm / 5"
013-110-145	14,5 cm / 5 ³ / ₄ "
013-110-160	16,0 cm / 6 ¹ / ₄ "
013-110-180	18,0 cm / 7"
013-110-200	20,0 cm / 8"
013-110-250	25,0 cm / 10"
013-110-300	30,0 cm / 12"

MOD. USA

013-130-120	12,0 cm / 4 ³ / ₄ "
013-130-130	13,0 cm / 5"
013-130-145	14,5 cm / 5 ³ / ₄ "
013-130-155	15,5 cm / 6"
013-130-180	18,0 cm / 7"
013-130-210	21,0 cm / 8"
013-130-250	25,0 cm / 10"
013-130-310	31,0 cm / 12"



schmal
 narrow
 estrecha
 stretti



MOD. USA

013-140-120	12,0 cm / 4 ³ / ₄ "
013-140-130	13,0 cm / 5"
013-140-145	14,5 cm / 5 ³ / ₄ "
013-140-155	15,5 cm / 6 ¹ / ₈ "

ADSON

013-150-120	12,0 cm / 4 ³ / ₄ "
013-150-150	15,0 cm / 6"

MICRO-ADSON

013-152-120	12,0 cm / 4 ³ / ₄ "
013-152-150	15,0 cm / 6"



MC INDOE

013-156-150 15,0 cm / 6"



SEMKEN

013-158-125 12,5 cm / 5"
013-158-150 15,0 cm / 6"



POTTS-SMITH

013-160-180 18,0 cm / 7"
013-160-210 21,0 cm / 8¹/₄"
013-160-250 25,0 cm / 10"



POTTS-SMITH

013-161-180 18,0 cm / 7"
013-161-210 21,0 cm / 8¹/₄"
013-161-250 25,0 cm / 10"



BROPHY

013-164-200 20,0 cm / 8"



BROPHY

013-165-200 20,0 cm / 8"



TAYLOR

013-168-175 17,5 cm / 7"



TAYLOR

013-169-175 17,5 cm / 7"

Dissektor Ende
 dissector end
 cabo disecador
 dissettore



013

Anatomische Pinzetten
 Dissecting Forceps
 Pinzas de disección
 Pinze anatomiche per dissezione



CUSHING
013-176-175 17,5 cm / 7"



CUSHING
013-177-175 17,5 cm / 7"



GERALD
013-178-180 18,0 cm / 7"



GERALD
013-179-180 18,0 cm / 7"



013-180-125 12,5 cm / 5"
013-180-155 15,5 cm / 6 1/8"

englische Modelle
 english patterns
 modelos ingleses
 modelli inglese



DUEHRSEN
013-184-200 20,0 cm / 8"



RAMSEY
013-186-180 18,0 cm / 7"



STANDARD

013-200-105	10,5 cm / 4 1/8"
013-200-115	11,5 cm / 4 1/2"
013-200-130	13,0 cm / 5"
013-200-145	14,5 cm / 5 3/4"
013-200-160	16,0 cm / 6 1/4"
013-200-180	18,0 cm / 7"
013-200-200	20,0 cm / 8"
013-200-250	25,0 cm / 10"
013-200-300	30,0 cm / 12"



013-210-115	11,5 cm / 4 1/2"
013-210-130	13,0 cm / 5"
013-210-145	14,5 cm / 5 3/4"
013-210-160	16,0 cm / 6 1/4"
013-210-180	18,0 cm / 7"
013-210-200	20,0 cm / 8"
013-210-250	25,0 cm / 10"
013-210-300	30,0 cm / 12"



013-220-130	13,0 cm / 5"
013-220-145	14,5 cm / 5 3/4"
013-220-160	16,0 cm / 6 1/4"



013-230-130	13,0 cm / 5"
013-230-145	14,5 cm / 5 3/4"
013-230-160	16,0 cm / 6 1/4"



013-240-115	11,5 cm / 4 1/2"
013-240-130	13,0 cm / 5"
013-240-145	14,5 cm / 5 3/4"
013-240-160	16,0 cm / 6 1/4"
013-240-180	18,0 cm / 7"
013-240-200	20,0 cm / 8"



013-241-130	13,0 cm / 5"
013-241-145	14,5 cm / 5 3/4"



013

Chirurgische Pinzetten
Tissue Forceps
Pinzas quirúrgicas
Pinze per chirurgia



USA MODELL

013-250-120	12,0 cm / 4 ³ / ₄ "
013-250-130	13,0 cm / 5"
013-250-140	14,5 cm / 5 ³ / ₄ "
013-250-155	15,5 cm / 6"
013-250-180	18,0 cm / 7"
013-250-210	21,0 cm / 8 ¹ / ₄ "
013-250-250	25,0 cm / 9 ³ / ₄ "
013-250-310	31,0 cm / 12 ¹ / ₄ "



USA MODELL

013-260-130	13,0 cm / 5"
013-260-145	14,5 cm / 5 ³ / ₄ "
013-260-155	15,5 cm / 6"



STILLE

013-270-150	15,0 cm / 6"
--------------------	--------------



STILLE

013-272-150	15,0 cm / 6"
--------------------	--------------



ADSON

013-280-120	12,0 cm / 4 ³ / ₄ "
013-280-150	15,0 cm / 6"



MIKRO-ADSON

013-282-120	12,0 cm / 4 ³ / ₄ "
013-282-150	15,0 cm / 6"



ADSON

013-284-120	12,0 cm / 4 ³ / ₄ "
--------------------	---



ADSON-BROWN

013-286-120	12,0 cm / 4 ³ / ₄ "
--------------------	---



STONE

013-288-150 15,0 cm / 6"



LERCHE

013-290-150 15,0 cm / 6"



ADLERKREUTZ

013-292-150 15,0 cm / 6"
013-292-200 20,0 cm / 8"



ADLERKREUTZ

013-294-150 15,0 cm / 6"
013-294-200 20,0 cm / 8"



GILLIES

013-296-150 15,0 cm / 6"



SEMKEN

013-298-125 12,5 cm / 5"
013-298-150 15,0 cm / 6"



TAYLOR

013-300-175 17,5 cm / 7"



TAYLOR

013-301-175 17,5 cm / 7"



013

Chirurgische Pinzetten
Tissue Forceps
Pinzas quirúrgicas
Pinze per chirurgia



GERALD
013-302-175 17,5 cm / 7"



GERALD
013-303-175 17,5 cm / 7"



CUSHING
013-304-175 17,5 cm / 7"



CUSHING
013-305-175 17,5 cm / 7"



POTTS-SMITH
013-310-180 18,0 cm / 7"
013-310-210 21,0 cm / 8 1/4"
013-310-250 25,0 cm / 10"



POTTS-SMITH
013-311-180 18,0 cm / 7"
013-311-210 21,0 cm / 8 1/4"
013-311-250 25,0 cm / 10"



BROPHY
013-314-200 20,0 cm / 8"



BROPHY
013-315-200 20,0 cm / 8"



WAUGH
013-318-200 20,0 cm / 8"



DUEHRSEN
013-320-200 20,0 cm / 8"



STILLE-BARRAYA
013-322-180 18,0 cm / 7"
013-322-200 20,0 cm / 8"
013-322-250 25,0 cm / 10"



013-326-180

FERRIS-SMITH
013-326-180 - 013-328-180 18,0 cm / 7"

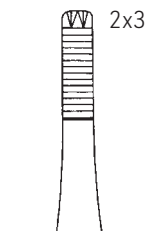

013-328-180



LANE
013-330-145 14,5 cm / 5³/₄"
013-330-175 17,5 cm / 7"



LANE
013-332-145 14,5 cm / 5³/₄"
013-332-175 17,5 cm / 7"



013

Chirurgische Pinzetten
Tissue Forceps
Pinzas quirúrgicas
Pinze per chirurgia

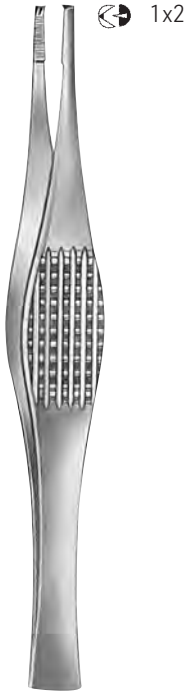

RAMSEY
013-334-180 18,0 cm / 7"

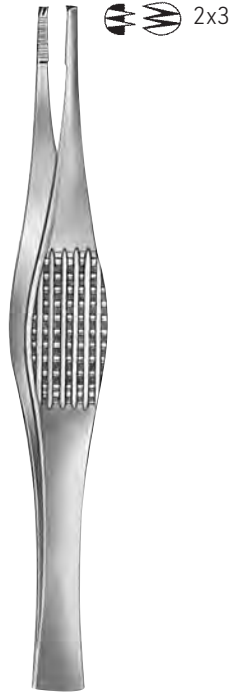

RAMSEY
013-336-180 18,0 cm / 7"



BONNEY
013-338-180 18,0 cm / 7"



BONNEY
013-340-180 18,0 cm / 7"



TREVES
013-342-130 13,0 cm / 5"
013-342-150 15,0 cm / 6"



BROWN
013-344-150 15,0 cm / 6"



DURANTE
013-350-145 14,5 cm / 5³/₄"
013-350-160 16,0 cm / 6¹/₄"
013-350-200 20,0 cm / 8"



RUSS. MODELL
013-360-150 15,0 cm / 6"
013-360-200 20,0 cm / 8"
013-360-250 25,0 cm / 10"



NELSON
013-400-230 23,0 cm / 9"



DUVAL
013-402-140 14,0 cm / 5 1/2"



COLLIN-DUVAL
013-404-001 - 013-404-003 20,0 cm / 8"

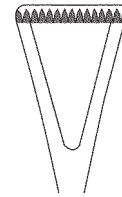

FIG. 1
013-404-001

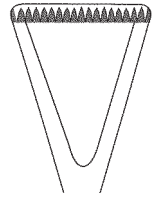

FIG. 2
013-404-002

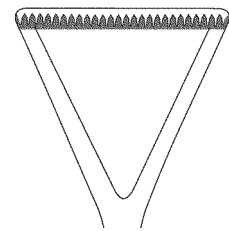

FIG. 3
013-404-003



SINGLEY-TUTTLE
013-406-230 23,0 cm / 9"



DENIS-BROWNE
013-408-200 20,0 cm / 8"



013

Mikro-Pinzetten
Micro Forceps
Pinzas para microscopia
Pinze per microscopia



GRAEFE

013-500-100 10,0 cm / 4"



GRAEFE

013-501-100 10,0 cm / 4"



GRAEFE

013-503-100 10,0 cm / 4"

↔ 1x2



GRAEFE

013-504-100 10,0 cm / 4"

↔ 1x2



GRAEFE

013-505-100 10,0 cm / 4"

↔ 1x2



GRAEFE

013-507-100 10,0 cm / 4"



ohne Stift
 without pin
 sin perno
 senza perno



mit Stift
 with pin
 con perno
 con perno



013-510-080 8,0 cm / 3 1/4"
013-510-090 9,0 cm / 3 1/2"
013-510-105 10,5 cm / 4 1/8"
013-510-115 11,5 cm / 4 1/2"
013-510-125 12,5 cm / 5"

013-511-080 8,0 cm / 3 1/4"
013-511-090 9,0 cm / 3 1/2"
013-511-105 10,5 cm / 4 1/8"
013-511-115 11,5 cm / 4 1/2"
013-511-125 12,5 cm / 5"

013-512-080 8,0 cm / 3 1/4"
013-512-090 9,0 cm / 3 1/2"
013-512-105 10,5 cm / 4 1/8"
013-512-115 11,5 cm / 4 1/2"
013-512-125 12,5 cm / 5"

013-513-080 8,0 cm / 3 1/4"
013-513-090 9,0 cm / 3 1/2"
013-513-105 10,5 cm / 4 1/8"
013-513-115 11,5 cm / 4 1/2"
013-513-125 12,5 cm / 5"



HUNTER
013-520-105 10,5 cm / 4 1/4"



HUNTER
013-521-105 10,5 cm / 4 1/4"



WALTER-CARMALT
013-522-105 10,5 cm / 4 1/4"



WALTER-CARMALT
013-523-105 10,5 cm / 4 1/4"



013

Splitterpinzetten, Mikro-Pinzetten
Splinter Forceps, Micro Forceps
Pinzas para espinas, Pinzas para microscopia
Pinze per schegge, Pinze per microscopia



013-524-100 10,0 cm / 4"



013-525-100 10,0 cm / 4"



013-526-100 10,0 cm / 4"



FEILCHENFELD

013-530-075 7,5 cm / 3 1/8"

013-530-090 9,0 cm / 3 1/2"

013-530-115 11,5 cm / 4 1/2"



SHAAF

013-550-090 9,0 cm / 3 1/2"



LITTAUER

013-552-085 8,5 cm / 3 1/3"



013-554-090 9,0 cm / 3 1/2"



DOUGLAS

013-556-090 9,0 cm / 3 1/2"



DOUGLAS

013-558-090 9,0 cm / 3 1/2"



BEER

013-560-090 9,0 cm / 3 1/2"



BARRAQUER

013-562-105 10,5 cm / 4 1/4"



FIG. 3

013-600-003 11,5 cm / 4 3/4"



FIG. 4

013-600-004 11,0 cm / 4 3/8"



FIG. 5

013-600-005 11,0 cm / 4 3/8"



FIG. 7

013-600-007 11,5 cm / 4 3/8"



013

Mikro-Pinzetten
Micro Forceps
Pinzas para microscopia
Pinze per microscopia

0,3 mm



9 mm

013-610-001 11,0 cm / 4³/₈"

0,3 mm x 90°



9 mm

013-610-002 11,0 cm / 4³/₈"

0,3 mm x 45°



9 mm

013-610-003 11,0 cm / 4³/₈"

0,3 mm x 45°



9 mm

diamantbeschichtet
diamond coated
diamantado
diamantato

013-610-004 11,0 cm / 4³/₈"

0,3 mm



9 mm

013-620-120 12,0 cm / 4³/₄"

0,3 mm x 45°



9 mm

013-623-135 13,5 cm / 5¹/₄"



YASARGIL
 013-651-003 - 013-651-005 22,0 cm / 8³/₄"



YASARGIL
 013-653-003 - 013-653-005 22,0 cm / 8³/₄"



HEIFETZ
 013-655-003 - 013-655-005 22,0 cm / 8³/₄"

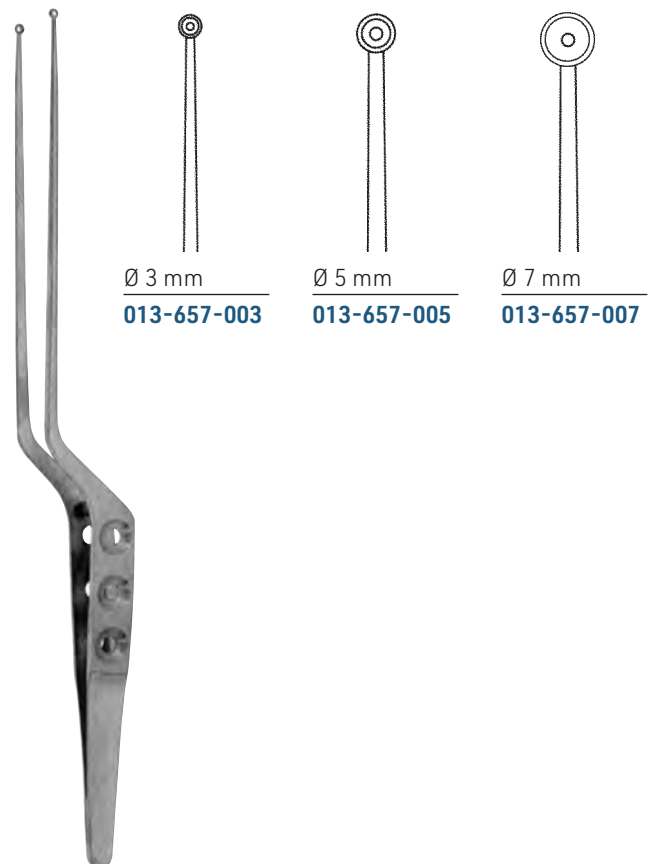

YASARGIL-SAMI
 013-657-003 - 013-657-007 24,0 cm / 9¹/₂"



013

Tumor- und Gewebefäßpinzetten, Mikro-Pinzetten
Tumor and Tissue Grasping Forceps, Micro-Forceps
Pinzas de agarre para tejido y tumor, Micro-Pinzas
Pinze per afferare tessuti e tumori, Micro-Pinze



SAMI

013-675-230 23,0 cm / 9"



SAMI

013-677-230 23,0 cm / 9"



HUNT

013-679-200 20,0 cm / 8"



YASARGIL

013-681-180 18,0 cm / 7"
013-681-200 20,0 cm / 8"
013-681-220 22,0 cm / 8³/₄"
013-681-240 24,0 cm / 9¹/₂"



YASARGIL

013-683-180 18,0 cm / 7"
013-683-200 20,0 cm / 8"
013-683-220 22,0 cm / 8³/₄"
013-683-240 24,0 cm / 9¹/₂"



YASARGIL

013-685-180 18,0 cm / 7"



013-690-150 15,0 cm / 6"
013-690-180 18,0 cm / 7"
013-690-210 21,0 cm / 8¹/₄"



013-691-150 15,0 cm / 6"
013-691-180 18,0 cm / 7"
013-691-210 21,0 cm / 8¹/₄"



013-692-150 15,0 cm / 6"
013-692-180 18,0 cm / 7"
013-692-210 21,0 cm / 8¹/₄"

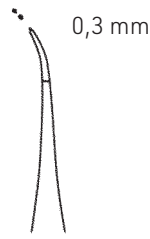

013-693-150 15,0 cm / 6"
013-693-180 18,0 cm / 7"
013-693-210 21,0 cm / 8¹/₄"



013-695-003



013-695-006



013-697-006

013-695-003 - 013-697-006 18,5 cm / 7¹/₄"



013

Mikro-Knüpfpinzetten
Micro Suture Tying Forceps
Micro-pinzas de ligadura
Micro-pinze per legature

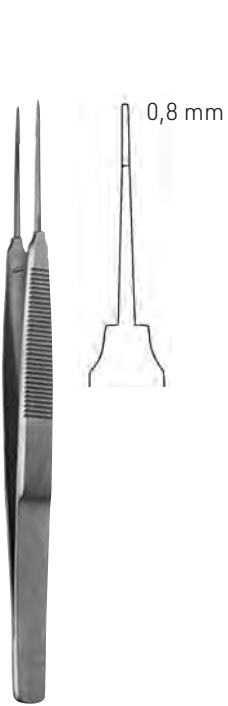

AUSTIN

013-698-140 14,0 cm / 5 1/2"

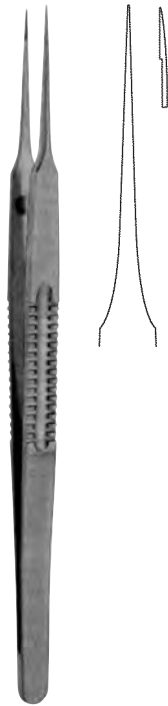

013-700-185 18,5 cm / 7 1/4"

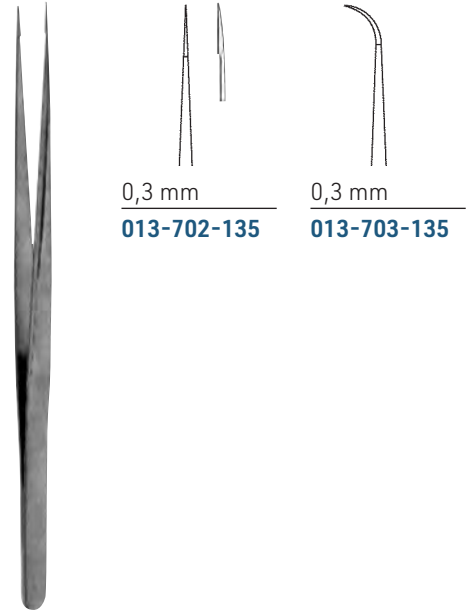

VISE

013-702-135 - 013-703-135 13,5 cm / 5 1/4"

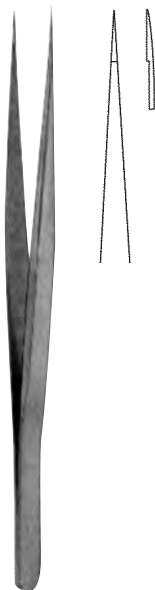

013-704-120 12,0 cm / 4 3/4"

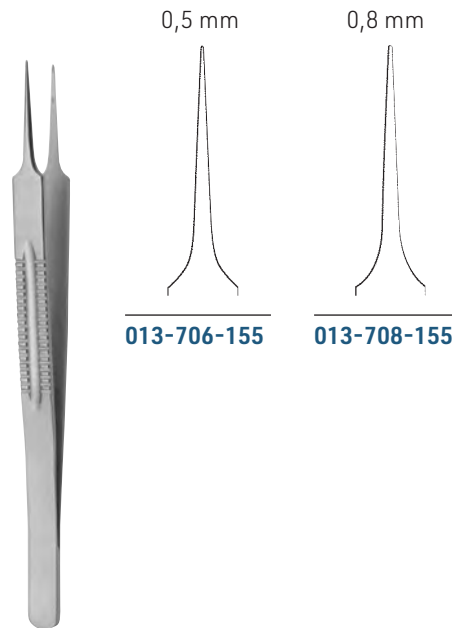

LAZAR

013-706-155 - 013-708-155 15,5 cm / 6 1/8"



Profil
 Serration
 Perfil
 Profilo

0,4 mm

ADSON

- 013-800-120** 12,0 cm / 4³/₄"
013-800-150 15,0 cm / 6"



Profil
 Serration
 Perfil
 Profilo

0,4 mm

MICRO-ADSON

- 013-802-120** 12,0 cm / 4³/₄"
013-802-150 15,0 cm / 6"



Profil
 Serration
 Perfil
 Profilo

0,4 mm

STANDARD

- 013-810-145** 14,5 cm / 5³/₄"
013-810-160 16,0 cm / 6¹/₄"
013-810-180 18,0 cm / 7"
013-810-200 20,0 cm / 8"
013-810-250 25,0 cm / 10"



013-820-175

Profil
 Serration
 Perfil
 Profilo

0,4 mm

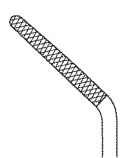

013-821-175

Profil
 Serration
 Perfil
 Profilo

0,4 mm

CUSHING

- 013-820-175 - 013-821-175** 17,5 cm / 7"



Profil
 Serration
 Perfil
 Profilo

0,4 mm

CUSHING-TAYLOR

- 013-823-180** 18,0 cm / 7"



013

Pinzetten mit Hartmetalleinlagen
 Forceps with tungsten carbide inserts
 Pinzas con bocas de carburo tungsteno
 Pinze con morsi in carburo di tungsteno



Profil
 Serration
 Perfil
 Profilo
 0,4 mm

POTTS-SMITH

- 013-840-150** 15,0 cm / 6"
- 013-840-180** 18,0 cm / 7"
- 013-840-200** 20,0 cm / 8"
- 013-840-230** 23,0 cm / 9"
- 013-840-250** 25,0 cm / 10"



Profil
 Serration
 Perfil
 Profilo
 0,4 mm

SEMKEN

- 013-850-150** 15,0 cm / 6"

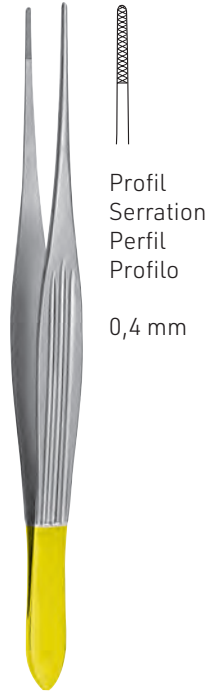

Profil
 Serration
 Perfil
 Profilo
 0,4 mm

MC INDOE

- 013-860-150** 15,0 cm / 6"

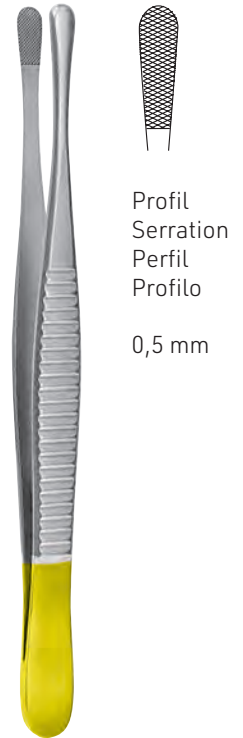

Profil
 Serration
 Perfil
 Profilo
 0,5 mm

WANGENSTEEN

- 013-880-150** 15,0 cm / 6"
- 013-880-230** 23,0 cm / 9"
- 013-880-250** 25,0 cm / 10"



Profil
 Serration
 Perfil
 Profilo
 0,4 mm

ADSON

- 013-900-120** 12,0 cm / 4³/₄"
- 013-900-150** 15,0 cm / 6"



Profil
 Serration
 Perfil
 Profilo
 0,4 mm

MICRO-ADSON

- 013-902-120** 12,0 cm / 4³/₄"
- 013-902-150** 15,0 cm / 6"



Profil
 Serration
 Perfil
 Profilo
 0,4 mm

ADSON-BROWN

- 013-905-120** 12,0 cm / 4³/₄"

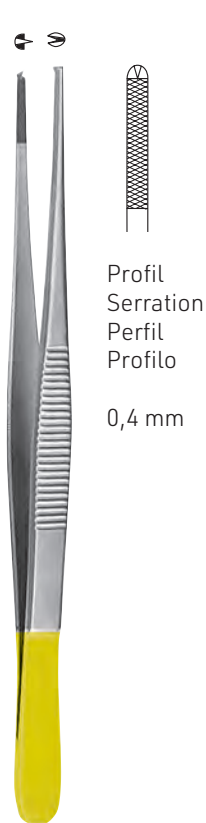

Profil
 Serration
 Perfil
 Profilo
 0,4 mm

OEHLER

- 013-910-140** 14,0 cm / 5 1/2"
- 013-910-160** 16,0 cm / 6 1/4"
- 013-910-180** 18,0 cm / 7"
- 013-910-200** 20,0 cm / 8"
- 013-910-250** 25,0 cm / 10"
- 013-910-300** 30,0 cm / 12"



BONNEY

- 013-920-180** 18,0 cm / 7"

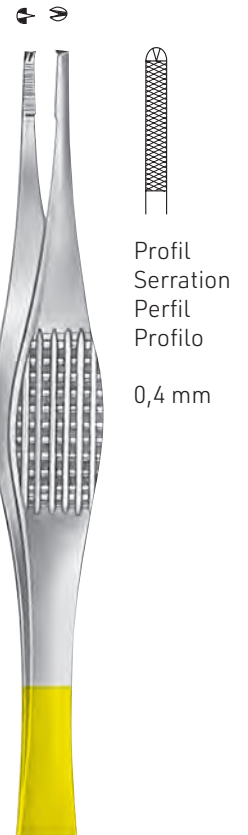

Profil
 Serration
 Perfil
 Profilo
 0,4 mm

FERRIS-SMITH

- 013-930-180** 18,0 cm / 7"

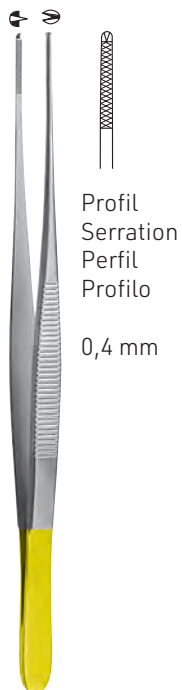

Profil
 Serration
 Perfil
 Profilo
 0,4 mm

SEMKEN

- 013-950-150** 15,0 cm / 6"



Profil
 Serration
 Perfil
 Profilo
 0,4 mm

GILLIES

- 013-960-150** 15,0 cm / 6"



DEBAKEY

- 013-980-150 - 013-982-150** 15,0 cm / 6"
- 013-980-190 - 013-982-190** 19,0 cm / 7 1/2"
- 013-980-240 - 013-982-240** 24,0 cm / 9 1/2"



013-980-150
013-980-190
013-980-240



013-982-150
013-982-190
013-982-240



013

Splitter-Zangen
Splinter Forceps
Pinzas para espinas
Pinze per achegge



013-990-135

013-991-135

STIEGLITZ

013-990-135 - 013-991-135 13,5 cm / 5 1/4"



013-992-135

013-993-135

STIEGLITZ

013-992-135 - 013-993-135 13,5 cm / 5 1/4"



PEET

013-995-115 11,5 cm / 4 1/2"



013-998-150

013-999-150

RALK (VIRTUS)

013-998-150 - 013-999-150 15,0 cm / 6"



015

Klemmen, Korn- und
Tupferzangen
Forceps, Dressing and
Sponge Forceps
Pinzas, Pinzas para torundo y
vendajes
Pinze, Pinze per medicatura
e tamponi



015

Klemmen
Clamps
Pinzas
Pinze



015-036-240 24,0 cm / 9 1/2"



SCHWARTZ
014-945-200 20,0 cm / 8"

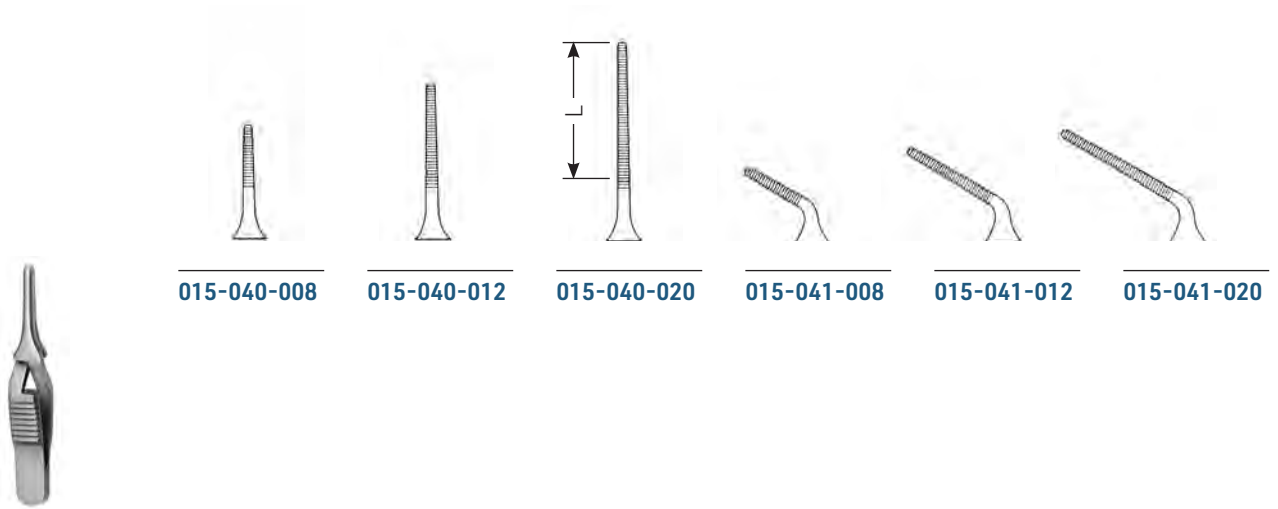

DIETRICH

015-040-008	8 mm (L)
015-040-012	12 mm (L)
015-040-020	20 mm (L)
015-041-008	8 mm (L)
015-041-012	12 mm (L)
015-041-020	20 mm (L)



DEBAKEY-DIETRICH

015-044-010	10 mm (L)
015-044-014	14 mm (L)
015-044-020	20 mm (L)
015-045-010	10 mm (L)
015-045-014	14 mm (L)
015-045-020	20 mm (L)



015

Klemmen
Clamps
Pinzas
Pinze



015-050-035



015-050-050

DIEFENBACH

015-050-035 3,5 cm / 1 1/2"
015-050-050 5,0 cm / 2"



015-051-035



015-051-050

DIEFENBACH

015-051-035 3,5 cm / 1 1/2"
015-051-050 5,0 cm / 2"



JOHNS-HOPKINS

015-060-050 5,0 cm / 2"
015-060-065 6,5 cm / 2 1/2"
015-060-075 7,5 cm / 3"

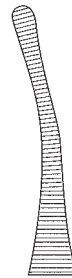

JOHNS-HOPKINS

015-061-050 5,0 cm / 2"
015-061-065 6,5 cm / 2 1/2"
015-061-075 7,5 cm / 3"



HESS

L

015-071-020 20 mm
015-071-030 30 mm



HALSTED-MOSQUITO

015-100-125 - 015-103-125 12,5 cm / 5"
 015-100-140 - 015-103-140 14,0 cm / 5 1/2"

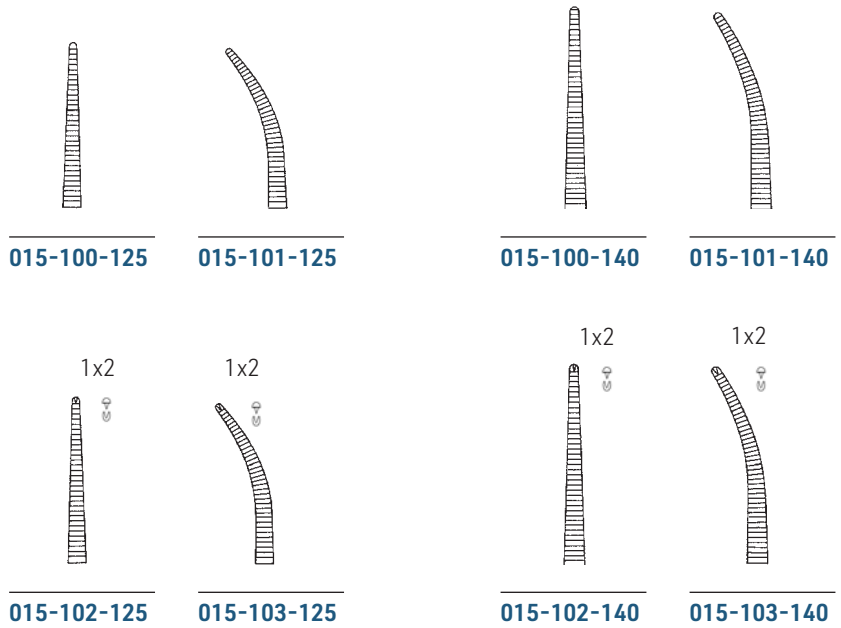

HALSTED-MOSQUITO

015-100-180 - 015-103-180 18,0 cm / 7"
 015-100-210 - 015-103-210 21,0 cm / 8 1/4"

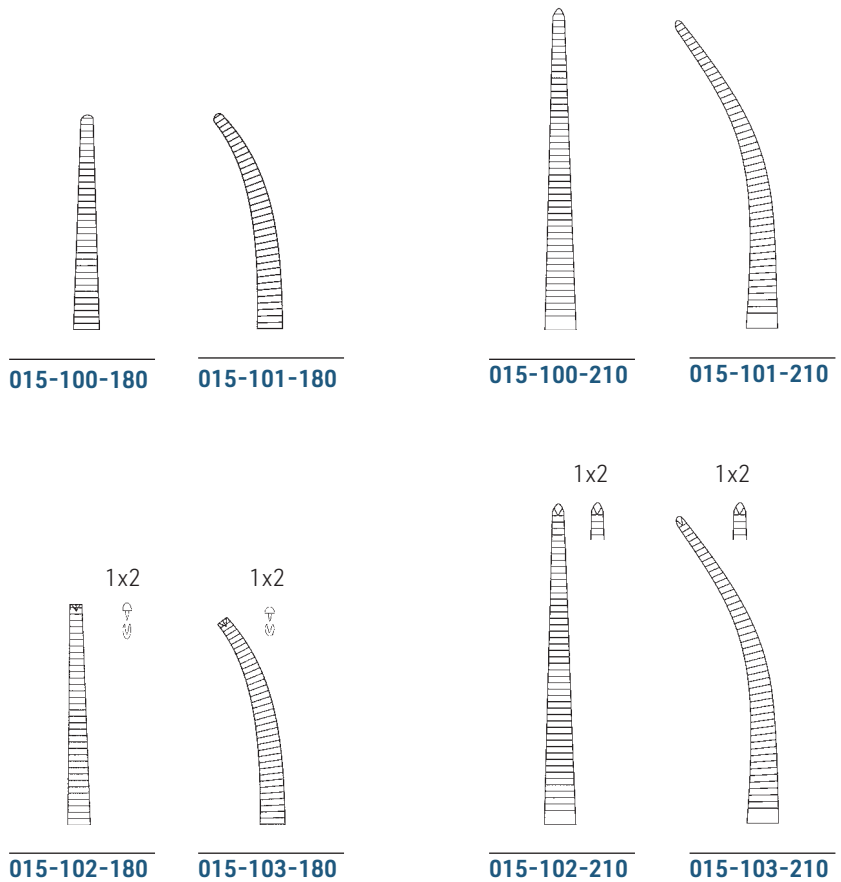



015

Klemmen
Forceps
Pinzas
Pinze

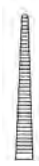

015-110-100



015-111-100



015-110-120



015-111-120



015-112-100

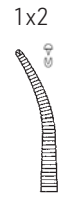

015-113-100



015-112-120



015-113-120

MICRO-MOSQUITO

015-110-100 - 015-113-100 10,0 cm / 4"
015-110-120 - 015-113-120 12,0 cm / 4³/₄"

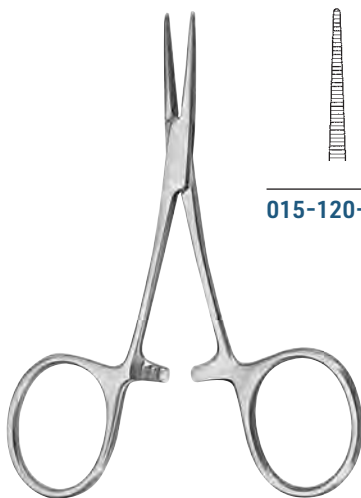

015-120-100



015-121-100

HARTMANN

015-120-100 - 015-121-100 10,0 cm / 4"

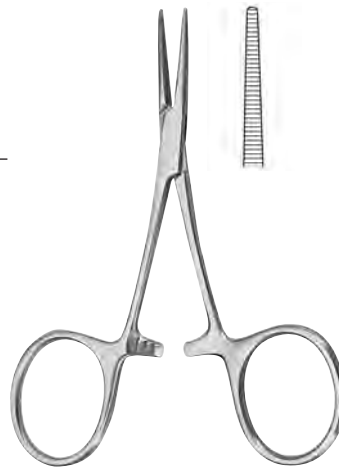

CARREL

015-130-085 8,5 cm / 3¹/₃"



TERRIER

015-140-085 8,5 cm / 3¹/₃"



KROENLEIN
 015-150-130 13,0 cm / 5"

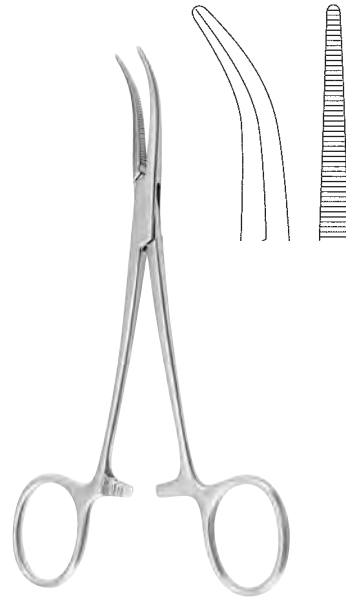

MOSQUITO-DANDY
 015-151-120 12,0 cm / 4³/₄"



DANDY
 015-151-140 - 015-153-140 14,0 cm / 5¹/₂"

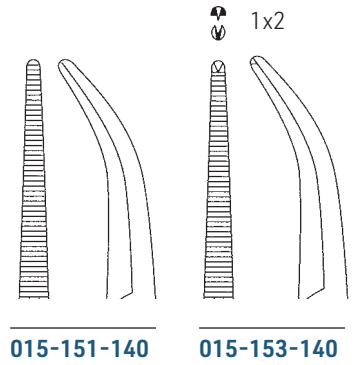

PROVIDENCE-HOSPITAL
 015-160-140 - 015-161-140 14,0 cm / 5¹/₂"

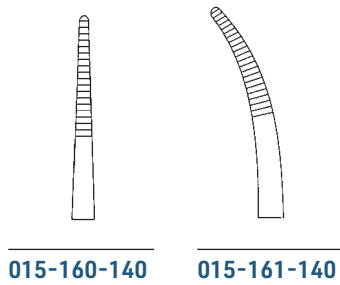

LERICHE
 015-170-150 - 015-173-150 15,0 cm / 6"

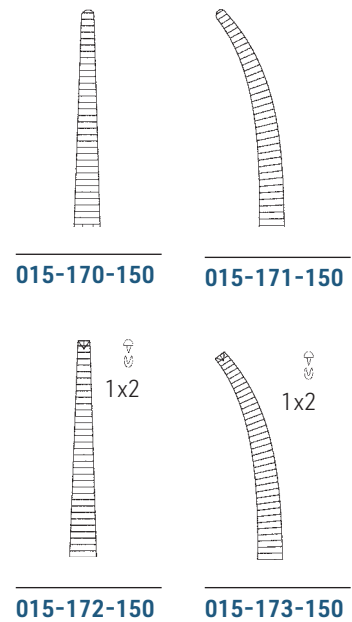



015

Klemmen
Forceps
Pinzas
Pinze



015-180-140



015-181-140

KELLY

015-180-140 - 015-181-140 14,0 cm / 5 1/2"



015-182-160

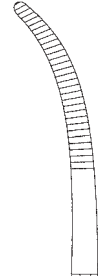

015-183-160

KELLY-RANKIN

015-182-160 - 015-183-160 16,0 cm / 6 1/4"



015-190-140

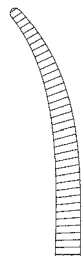

015-191-140

1x2



015-192-140

1x2

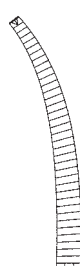

015-193-140

CRILE

015-190-140 - 015-193-140 14,0 cm / 5 1/2"

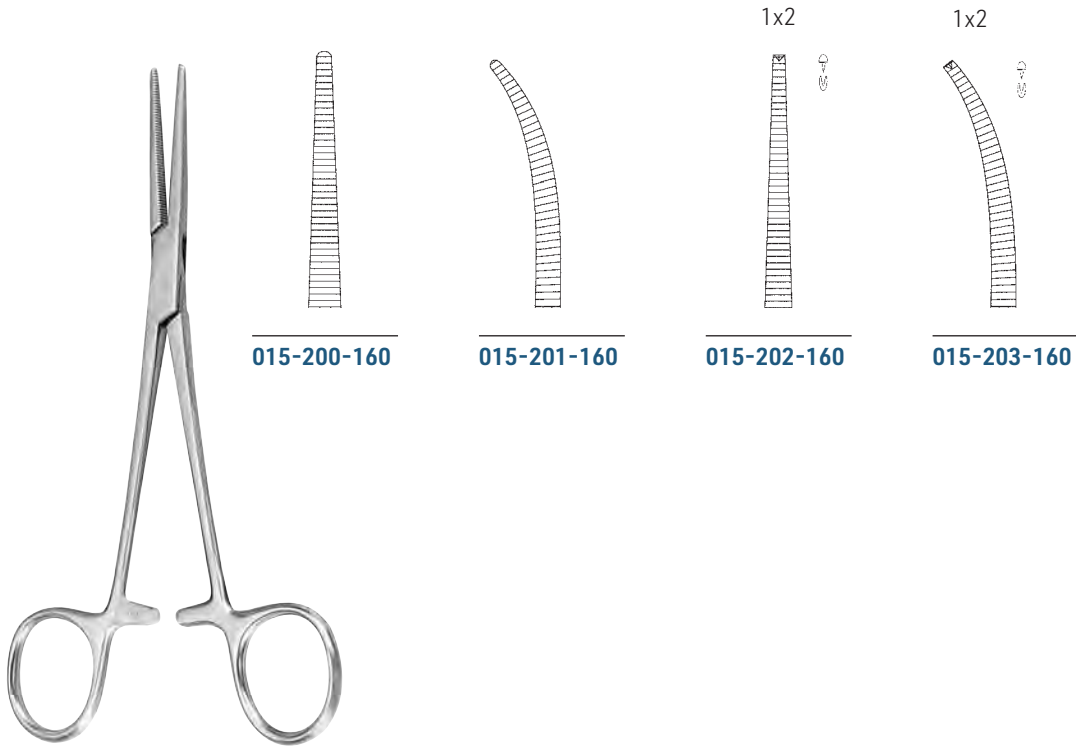

CRILE-RANKIN

015-200-160 - 015-203-160 16,0 cm / 6 1/4"



BABY-OVERHOLT

015-211-135 13,5 cm / 5 1/4"

DIXON-LOVELACE

015-220-150 - 015-222-150 15,0 cm / 6"



015

Klemmen
Forceps
Pinzas
Pinze



015-230-130



015-230-150



015-230-180



015-230-200



015-230-230

SPENCER-WELLS

- 015-230-130 13,0 cm / 5 1/8"
- 015-230-150 15,0 cm / 6"
- 015-230-180 18,0 cm / 7"
- 015-230-200 20,0 cm / 8"
- 015-230-230 23,0 cm / 9"

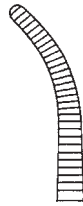

015-231-130

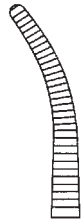

015-231-150

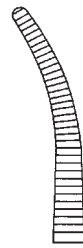

015-231-180

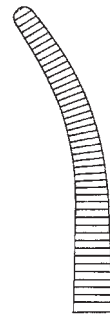

015-231-200

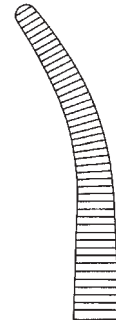

015-231-230

SPENCER-WELLS

- 015-231-130 13,0 cm / 5 1/8"
- 015-231-150 15,0 cm / 6"
- 015-231-180 18,0 cm / 7"
- 015-231-200 20,0 cm / 8"
- 015-231-230 23,0 cm / 9"

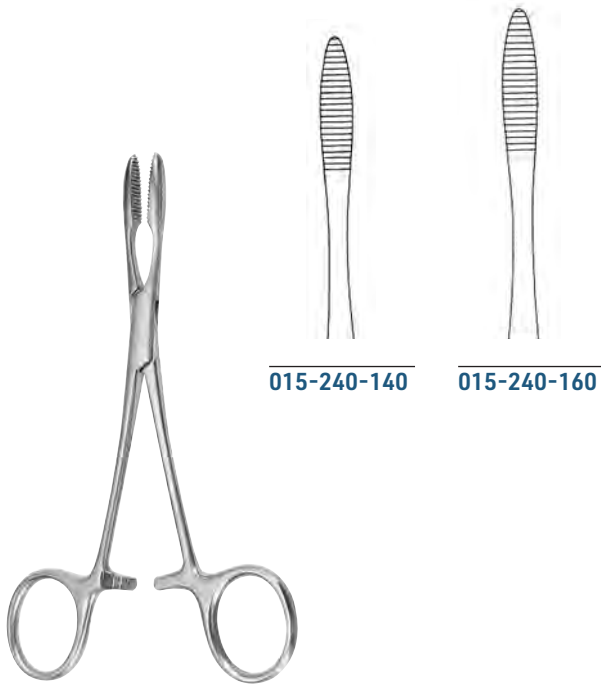

PEAN

- 015-240-140** 14,0 cm / 5 1/2"
- 015-240-160** 16,0 cm / 6 1/4"

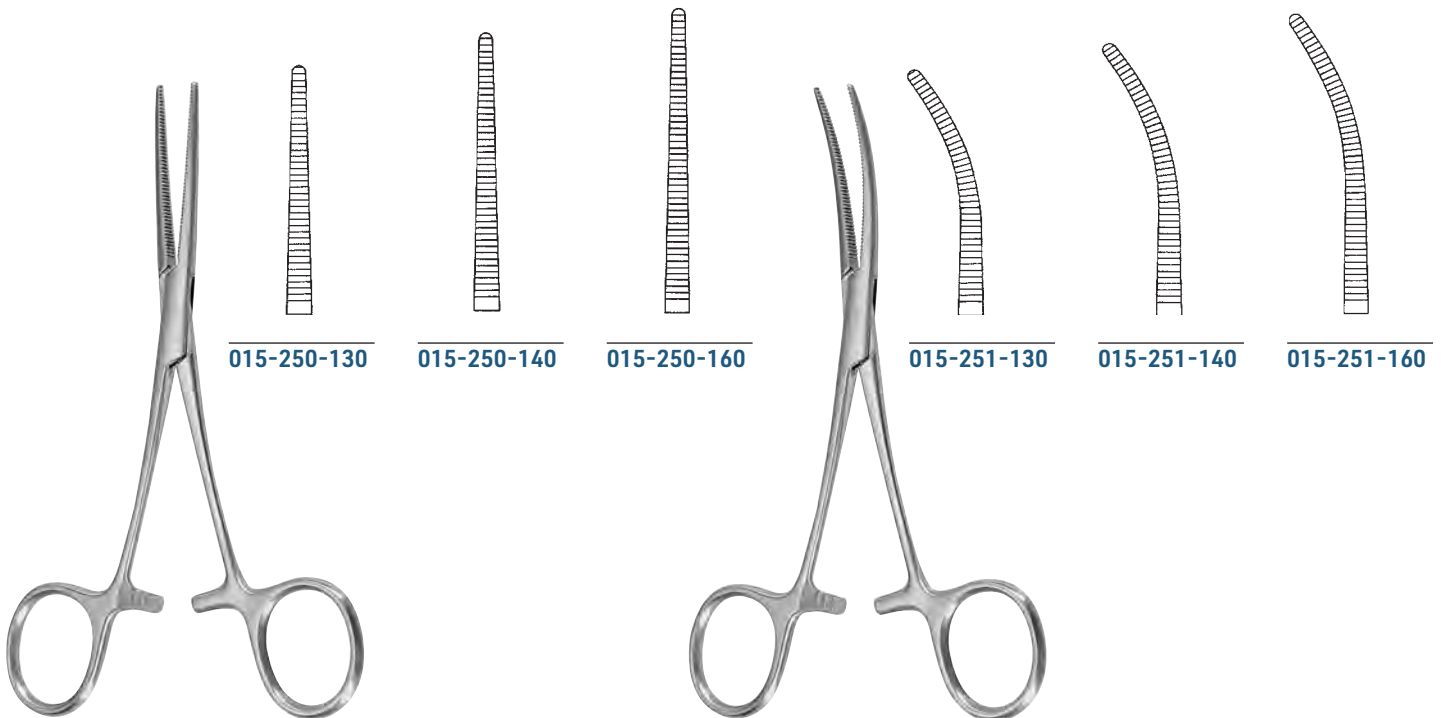

PEAN-DELICATE

- 015-250-130** 13,0 cm / 5 1/8"
- 015-250-140** 14,0 cm / 5 1/2"
- 015-250-160** 16,0 cm / 6 1/4"

PEAN-DELICATE

- 015-251-130** 13,0 cm / 5 1/8"
- 015-251-140** 14,0 cm / 5 1/2"
- 015-251-160** 16,0 cm / 6 1/4"



015

Klemmen
Forceps
Pinzas
Pinze



ROCHESTER-PEAN

015-260-140	14,0 cm / 5 1/2"
015-260-160	16,0 cm / 6 1/4"
015-260-180	18,0 cm / 7"
015-260-200	20,0 cm / 8"
015-260-220	22,0 cm / 8 3/4"
015-260-240	24,0 cm / 9 1/2"
015-260-260	26,0 cm / 10 1/4"
015-260-280	28,0 cm / 11"
015-260-300	30,0 cm / 11 3/4"



015-260-140

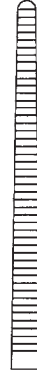

015-260-160



015-260-180

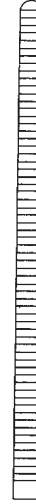

015-260-200

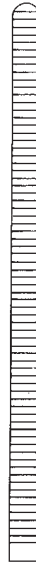

015-260-220

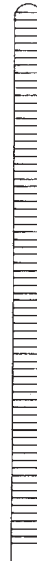

015-260-240

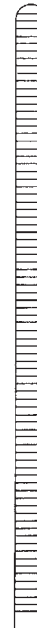

015-260-260

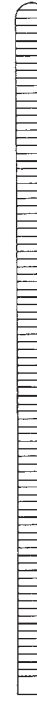

015-260-280

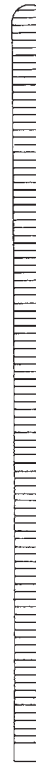

015-260-300



ROCHESTER-PEAN

015-261-140	14,0 cm / 5 1/2"
015-261-160	16,0 cm / 6 1/4"
015-261-180	18,0 cm / 7"
015-261-200	20,0 cm / 8"
015-261-220	22,0 cm / 8 3/4"
015-261-240	24,0 cm / 9 1/2"
015-261-260	26,0 cm / 10 1/4"
015-261-280	28,0 cm / 11"
015-261-300	30,0 cm / 11 3/4"

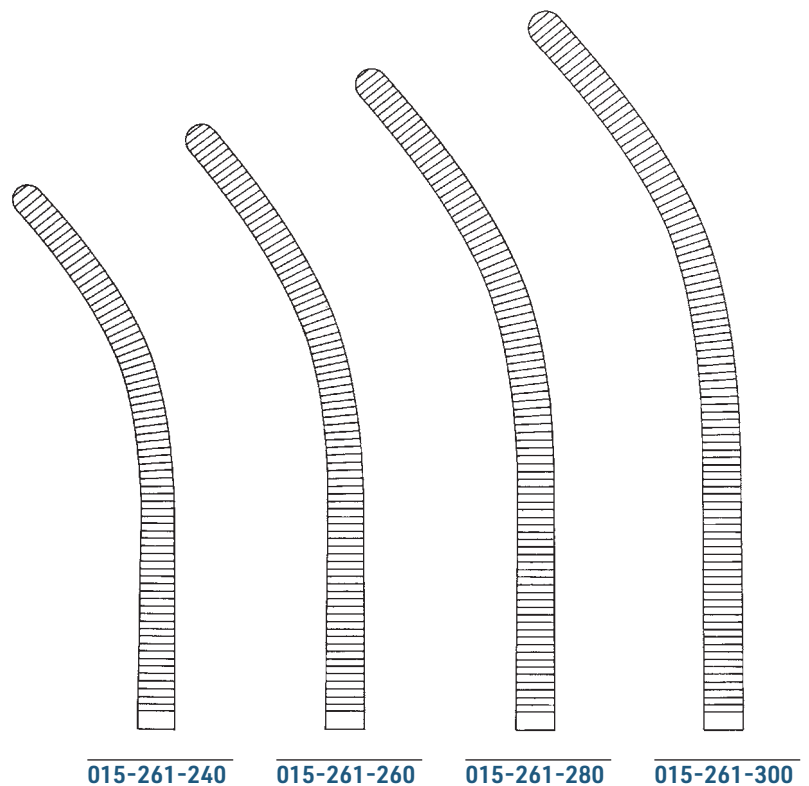
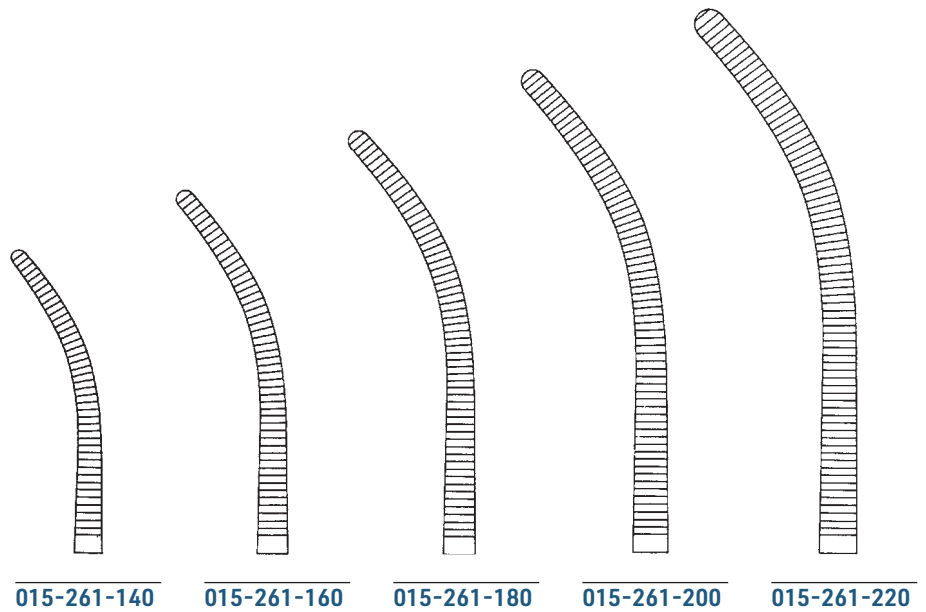



015

Klemmen
Forceps
Pinzas
Pinze

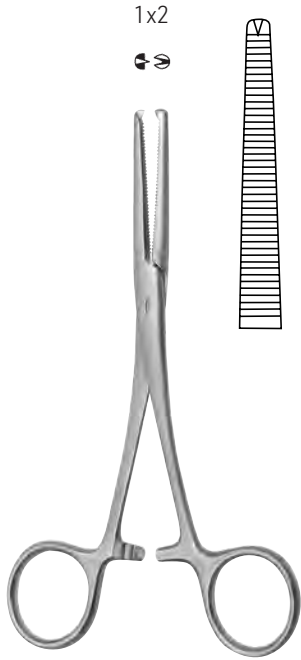

KOCHER

015-266-145 14,5 cm / 5³/₄"



KOCHER DELICATE

015-270-130 13,0 cm / 5¹/₈"
015-270-140 14,0 cm / 5¹/₂"
015-270-160 16,0 cm / 6¹/₄"

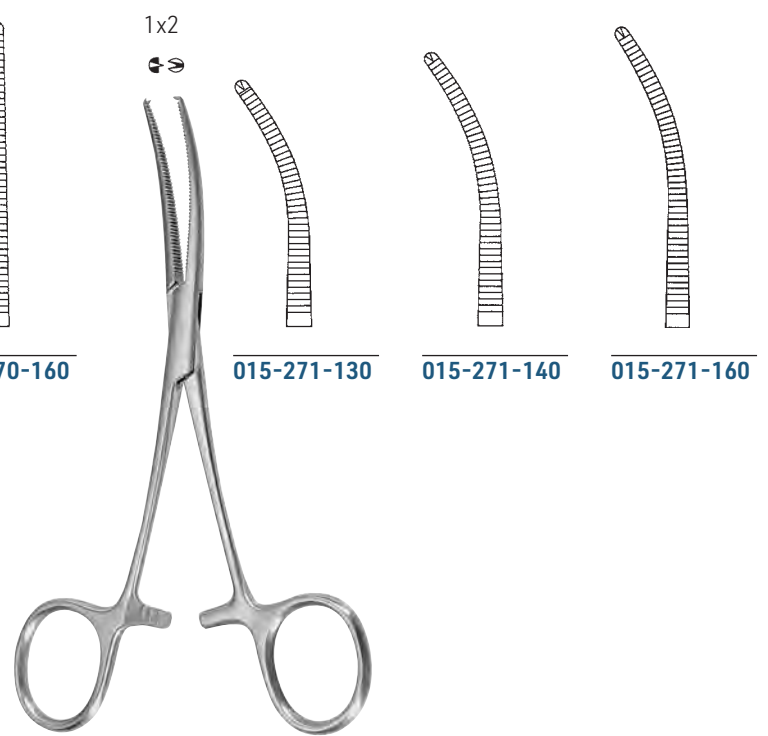
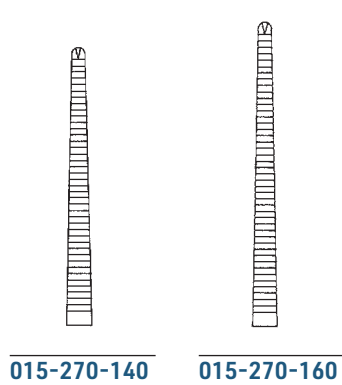

KOCHER DELICATE

015-271-130 13,0 cm / 5¹/₈"
015-271-140 14,0 cm / 5¹/₂"
015-271-160 16,0 cm / 6¹/₄"



KOCHER-OCHSNER

015-280-130	13,0 cm / 5 ¹ / ₈ "
015-280-140	14,0 cm / 5 ¹ / ₂ "
015-280-160	16,0 cm / 6 ¹ / ₄ "
015-280-180	18,0 cm / 7"
015-280-200	20,0 cm / 8"
015-280-220	22,0 cm / 8 ³ / ₄ "
015-280-240	24,0 cm / 9 ¹ / ₂ "
015-280-260	26,0 cm / 10 ¹ / ₄ "
015-280-300	30,0 cm / 11 ³ / ₄ "

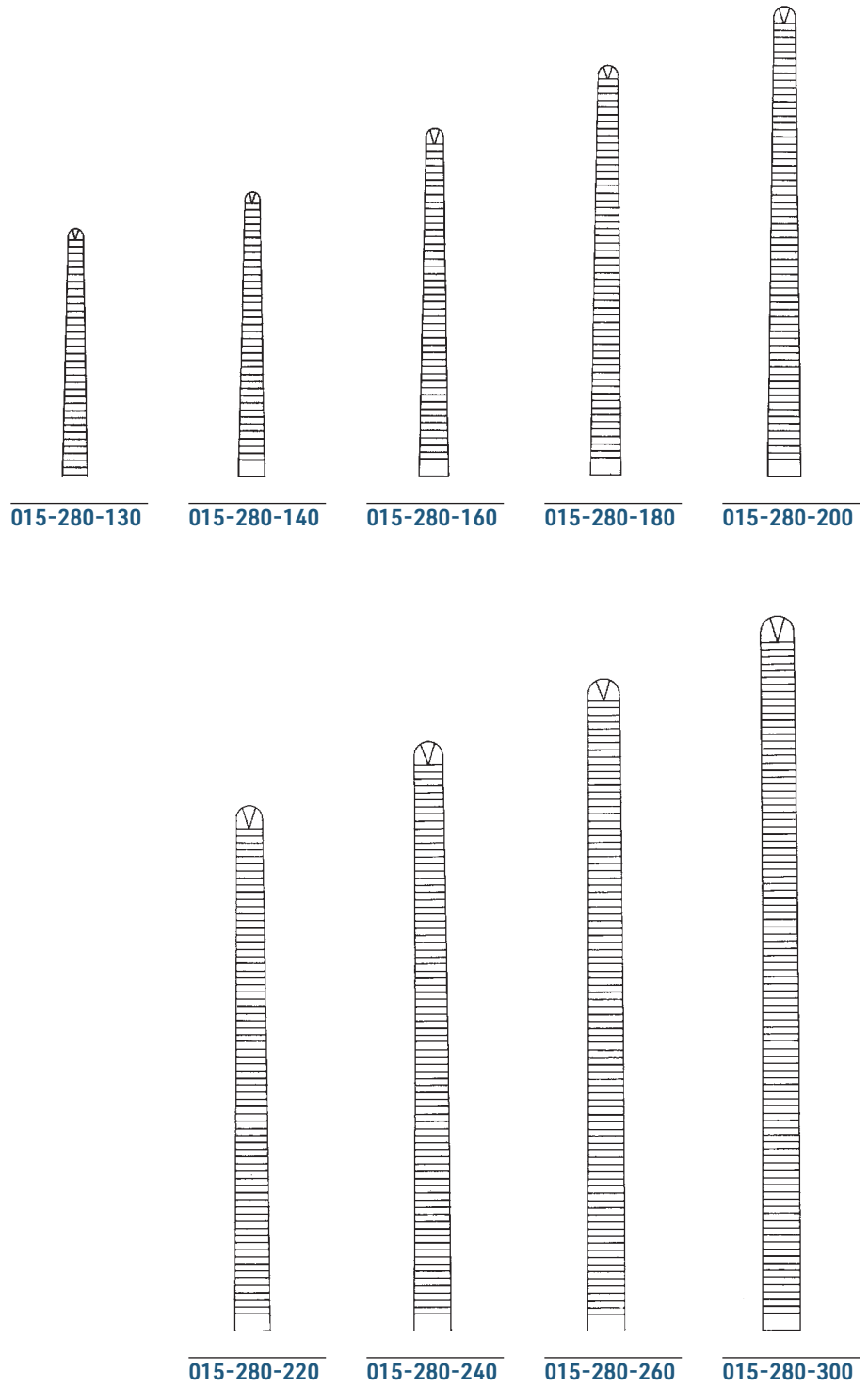



015

Klemmen
Forceps
Pinzas
Pinze

1x2



KOCHER-OCHSNER

015-281-130	13,0 cm / 5 ¹ / ₈ "
015-281-140	14,0 cm / 5 ¹ / ₂ "
015-281-160	16,0 cm / 6 ¹ / ₄ "
015-281-180	18,0 cm / 7"
015-281-200	20,0 cm / 8"
015-281-220	22,0 cm / 8 ³ / ₄ "
015-281-240	24,0 cm / 9 ¹ / ₂ "
015-281-260	26,0 cm / 10 ¹ / ₄ "
015-281-300	30,0 cm / 11 ³ / ₄ "

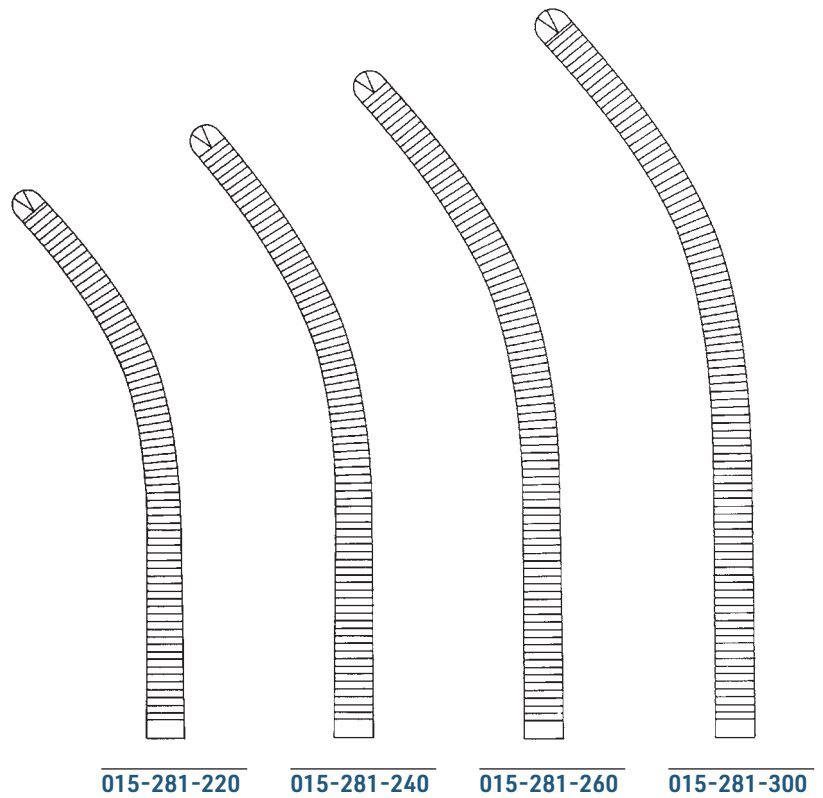
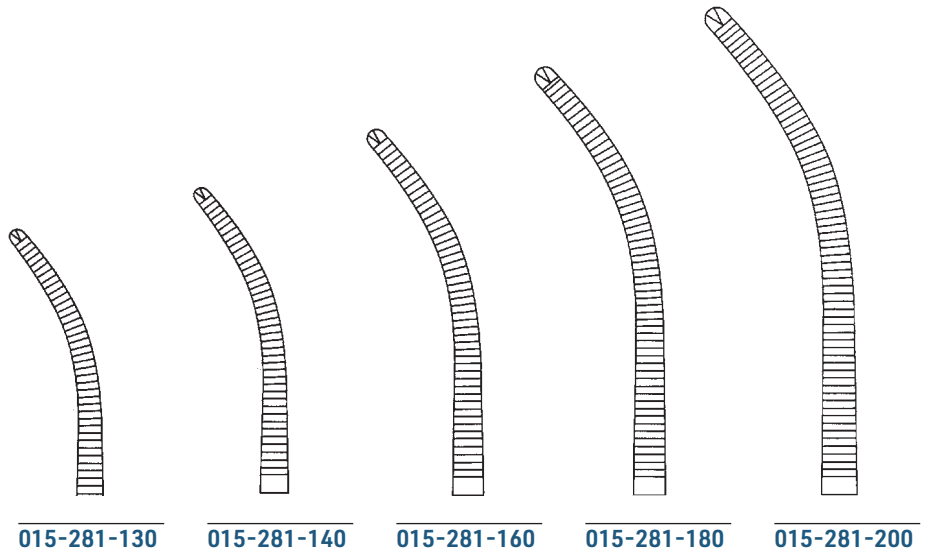

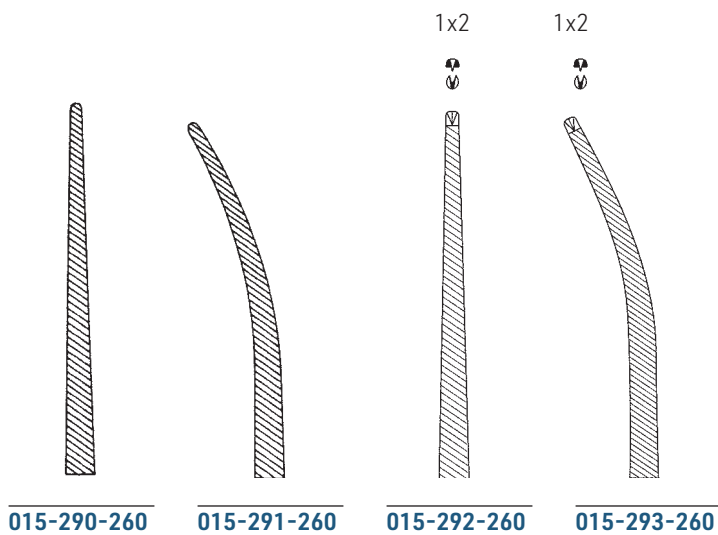
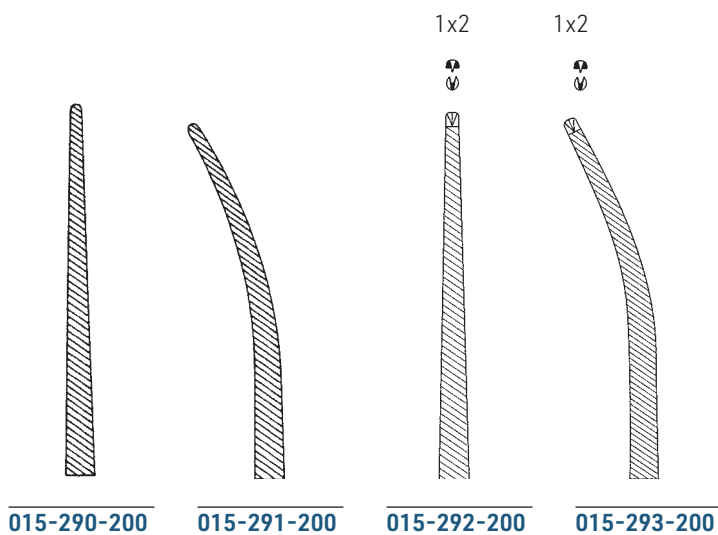

BENGOLEA

015-290-200 - 015-293-200 20,0 cm / 8"
 015-290-260 - 015-293-260 26,0 cm / 10¹/₄"



015

Gewebefäßzangen
Tissue Grasping Forceps
Pinzas para tejidos
Pinze da presa per tessuti



CHAPUT

015-300-130 13,0 cm / 5 1/8"



TUFFIER

015-310-130 13,0 cm / 5 1/8"



PENNINGTON

015-320-155 15,5 cm / 6 1/8"
015-320-200 20,0 cm / 8"



COLLIN

015-322-140 14,0 cm / 5 1/2"



COLLIN

015-330-160 - 015-332-160 16,0 cm / 6 1/4"

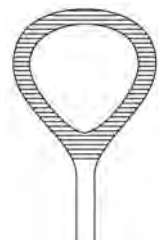

015-330-160

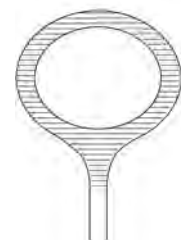

015-332-160



BUIE
015-335-210 21,0 cm / 8 1/4"



PRATT
015-338-150 15,0 cm / 6"



MARTEL
015-340-140 14,0 cm / 5 1/2"

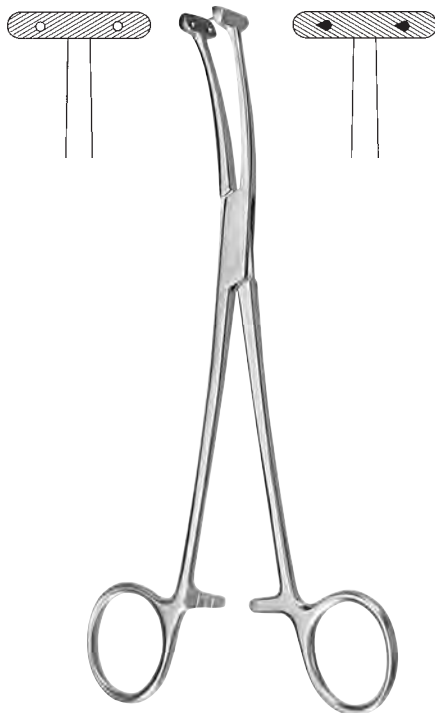

WILLET-MARTEL
015-345-190 19,0 cm / 7 1/2"

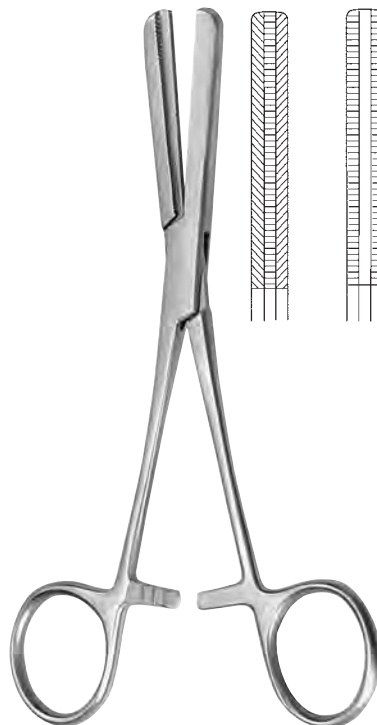

FERGUSON
015-350-160 16,0 cm / 6 1/4"
015-350-200 20,0 cm / 8"

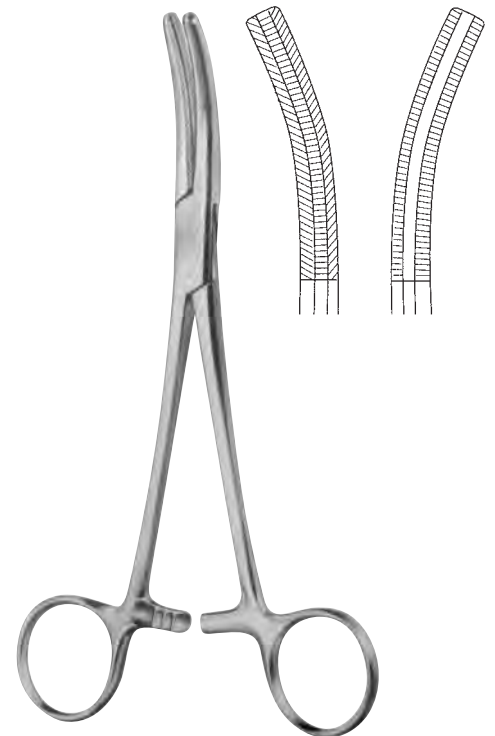

FERGUSON
015-351-160 16,0 cm / 6 1/4"
015-351-200 20,0 cm / 8"



015

Klemmen
Forceps
Pinzas
Pinze

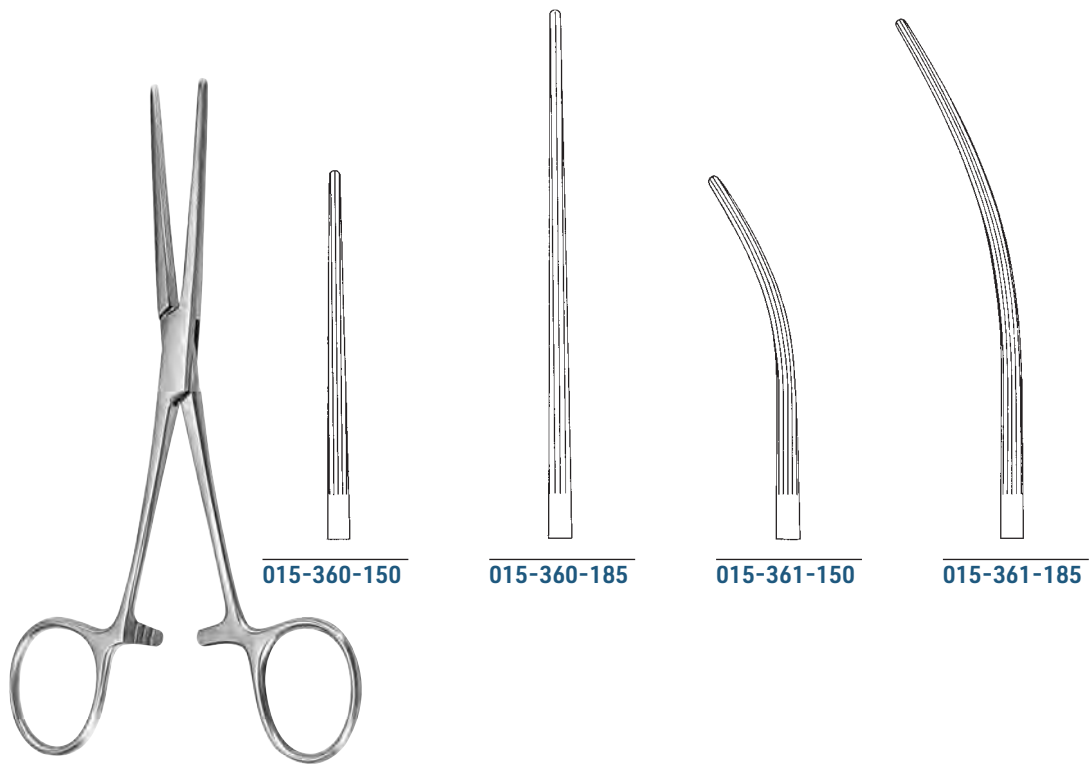

BAINBRIDGE

015-360-150 - 015-361-150	15,0 cm / 6"
015-360-185 - 015-361-185	18,5 cm / 7 1/4"

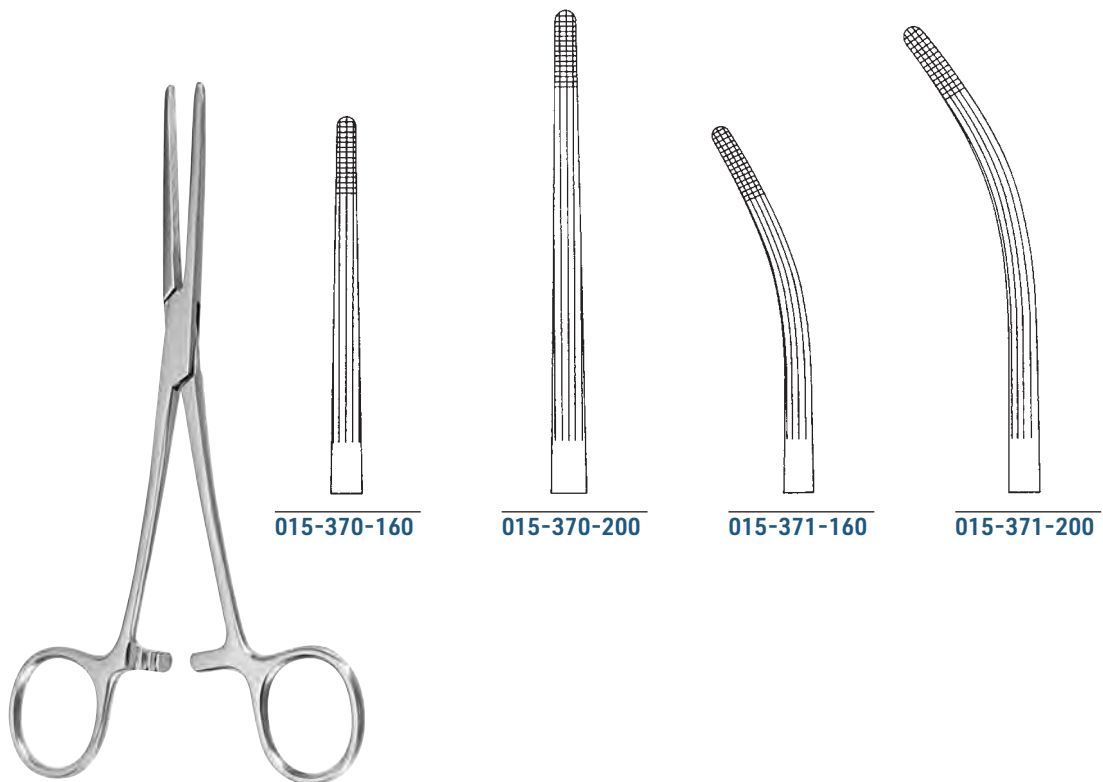

ROCHESTER-CARMALT

015-370-160 - 015-371-160	16,0 cm / 6 1/4"
015-370-200 - 015-371-200	20,0 cm / 8"



BABY-MIXTER

015-381-140 – 015-383-140 14,0 cm / 5 1/2"



BABY-MIXTER

015-385-180 18,0 cm / 7"

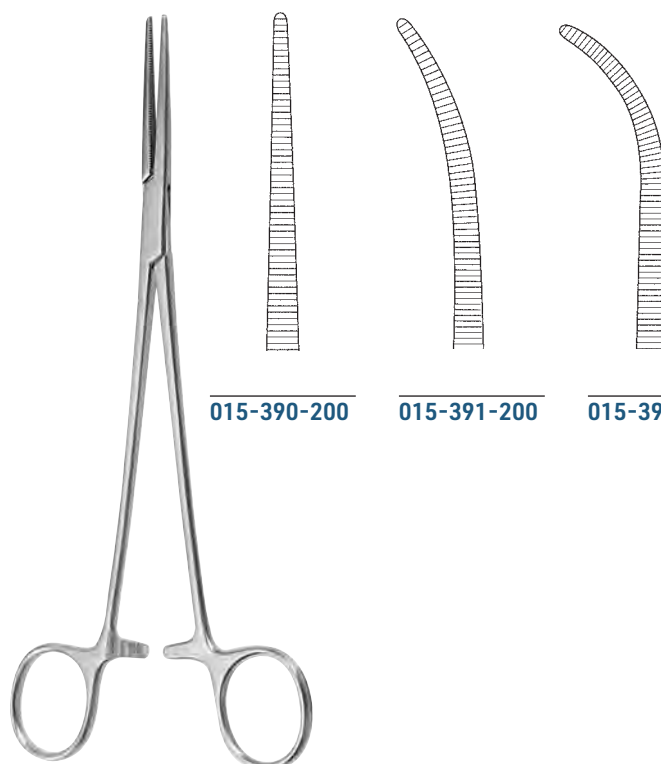

HEISS

015-390-200 – 015-393-200 20,0 cm / 8"



015

Klemmen
Forceps
Pinzas
Pinze

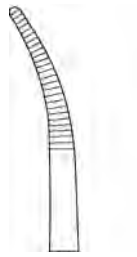

015-401-190



015-403-190

SCHNIDT

015-401-190 - 015-403-190 19,0 cm / 7 1/2"



015-410-180

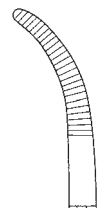

015-411-180

ADSON

015-410-180 - 015-411-180 18,5 cm / 7 1/4"

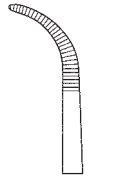

015-421-140

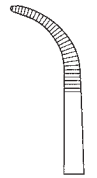

015-421-180

BABY-ADSON

015-421-140 14,0 cm / 5 1/2"
015-421-180 18,0 cm / 7"

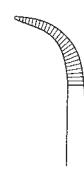

MIKRO-ADSON

015-423-140 14,0 cm / 5 1/2"

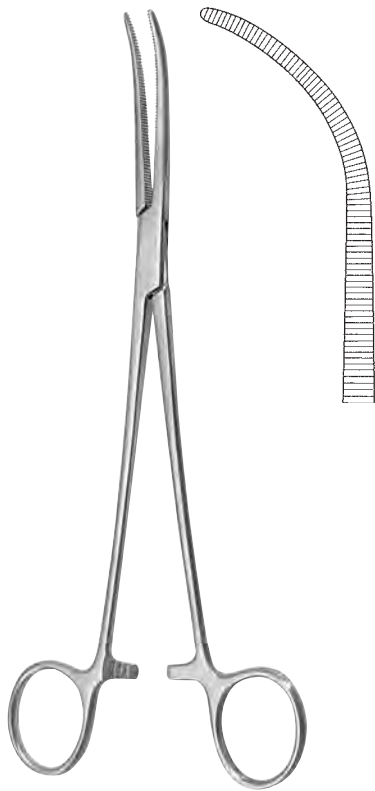

OVERHOLT-MIXTER
 015-431-210 21,0 cm / 8 1/4"

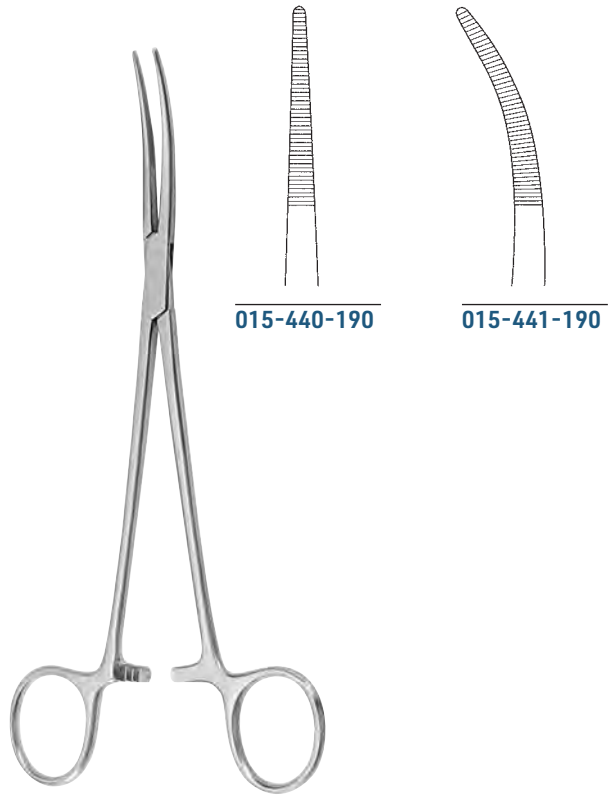

BIRKETT
 015-440-190 - 015-441-190 19,0 cm / 7 1/2"

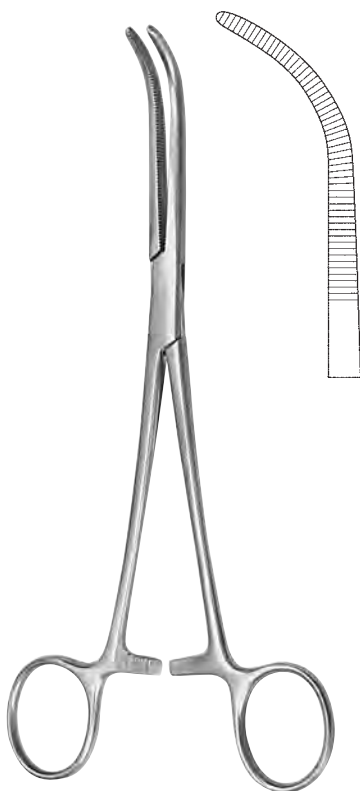

JOHNS HOPKINS
 015-451-200 20,0 cm / 8"

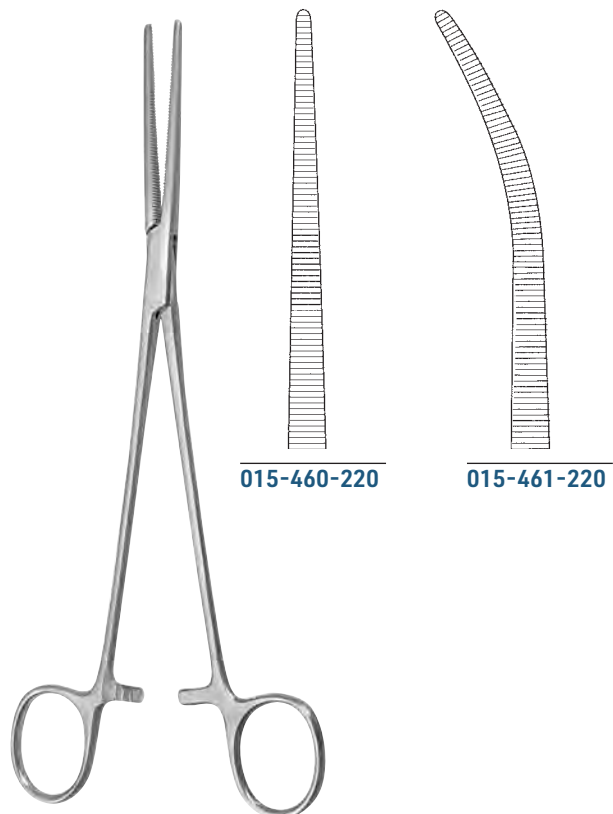

ROBERTS
 015-460-220 - 015-461-220 22,0 cm / 8 3/4"



015

Klemmen
Forceps
Pinzas
Pinze



015-470-240

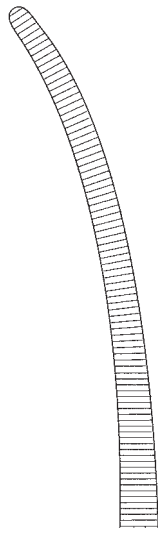

015-471-240

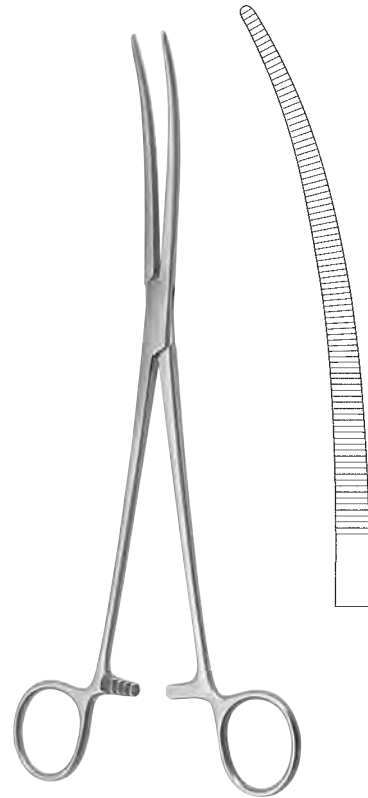

CRAFOORD

015-481-240 24,0 cm / 9 1/2"

SAROT

015-470-240 - 015-471-240 24,0 cm / 9 1/2"

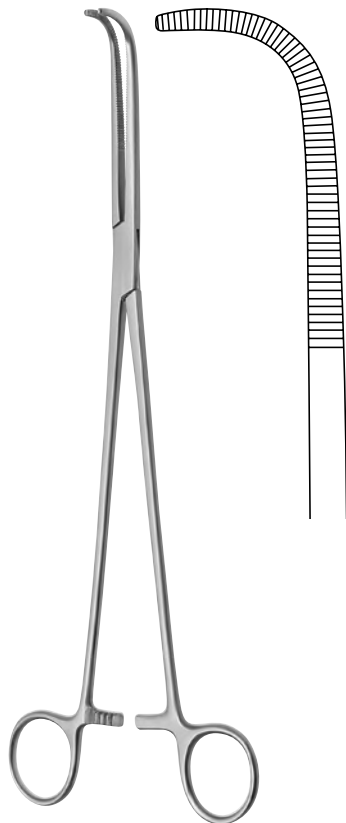

MIXTER-CRAFOORD

015-483-270 27,0 cm / 10 3/4"



CRAFOORD-SELLORS

015-485-220 22,0 cm / 8 3/4"
015-485-230 23,0 cm / 9"
015-485-240 24,0 cm / 9 1/2"



015-485-220

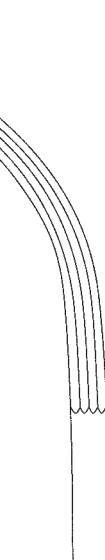

015-485-230

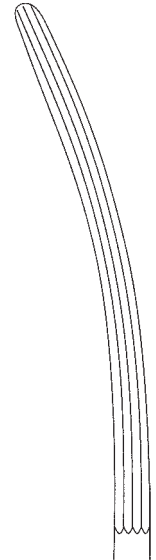

015-485-240

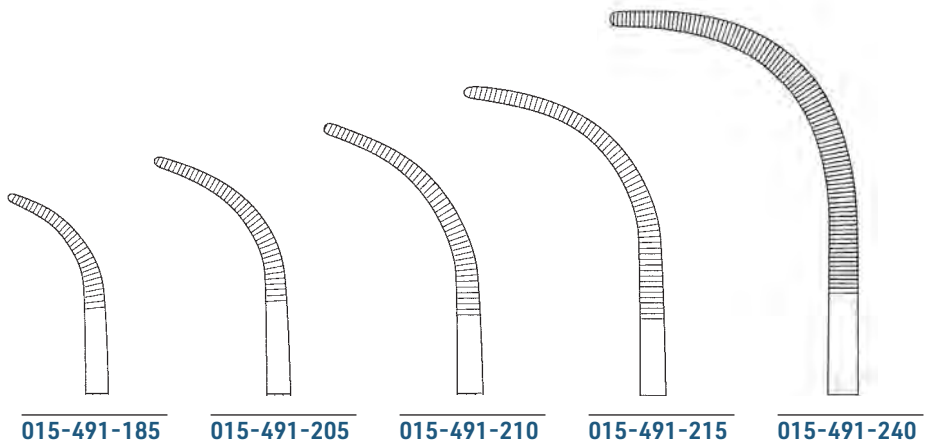
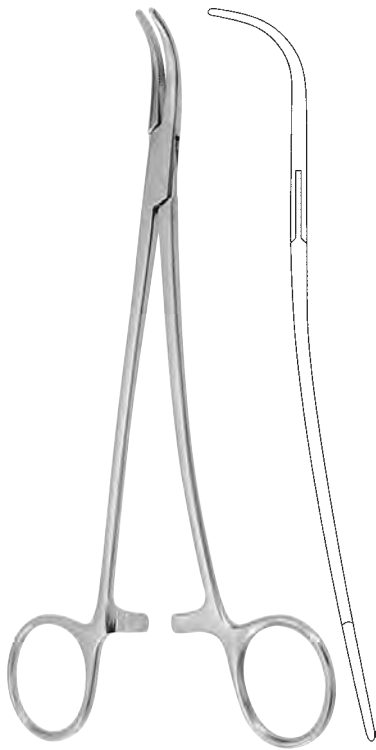

OVERHOLT

015-491-185	18,5 cm / 7 1/4"
015-491-205	20,0 cm / 8"
015-491-210	21,0 cm / 8 1/4"
015-491-215	21,5 cm / 8 1/2"
015-491-240	24,0 cm / 9 1/2"

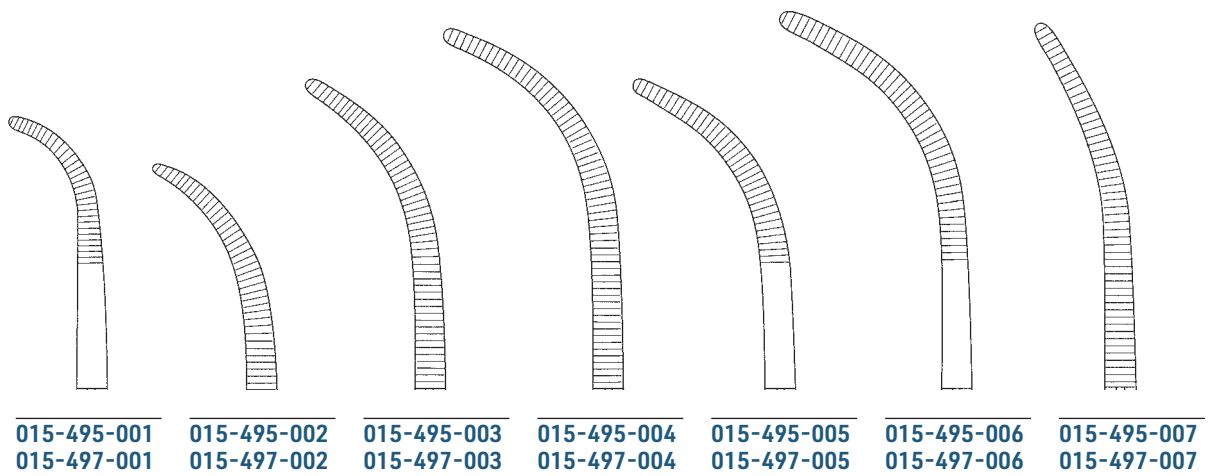

OVERHOLT-GEISSENDOERFER

015-495-001 - 015-495-007	21,0 cm / 8 1/4"
015-497-001 - 015-497-007	27,0 cm / 10 3/4"



015

Klemmen
Forceps
Pinzas
Pinze

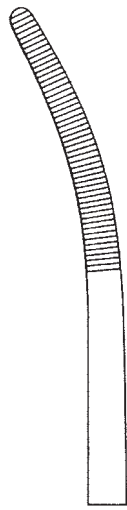

015-501-001

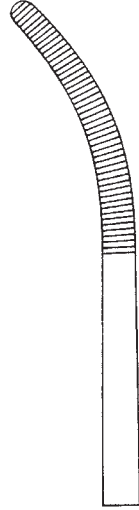

015-501-002

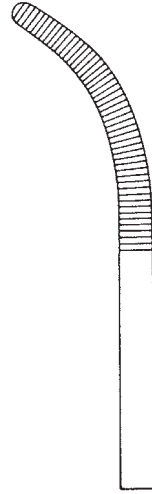

015-501-003

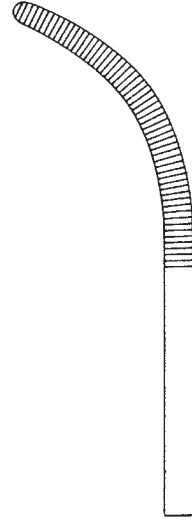

015-501-004

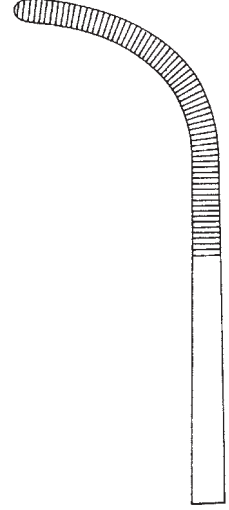

015-501-005

RUMEL

015-501-001 - 015-501-005 23,0 cm / 9"

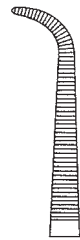

015-511-180



015-511-220



015-511-250



015-511-280

MINI-GEMINI

015-511-180 18,0 cm / 7"
015-511-220 22,0 cm / 8³/₄"
015-511-250 25,0 cm / 9³/₄"
015-511-280 28,0 cm / 11"

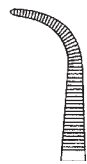

015-521-130



015-521-160



015-521-180

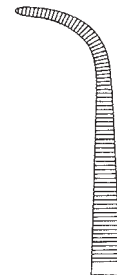

015-521-200

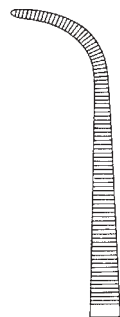

015-521-230

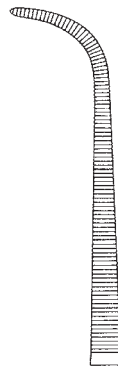

015-521-250

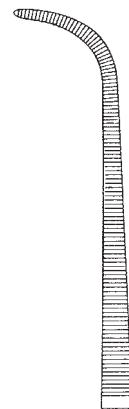

015-521-280



GEMINI

015-521-130	13,0 cm / 5 1/8"
015-521-160	16,0 cm / 6 1/4"
015-521-180	18,0 cm / 7"
015-521-200	20,0 cm / 8"
015-521-230	23,0 cm / 9"
015-521-250	25,0 cm / 9 3/4"
015-521-280	28,0 cm / 11"



015

Klemmen
Forceps
Pinzas
Pinze



015-530-210
015-530-260

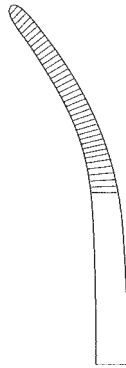

015-531-210
015-531-260

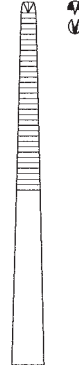

015-532-210
015-532-260

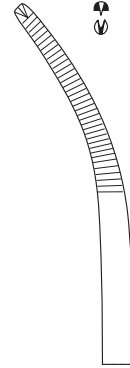

015-533-210
015-533-260

TOENNIS

015-530-210 - 015-533-210 21,0 cm / 8 1/4"
015-530-260 - 015-533-260 26,0 cm / 10 1/4"

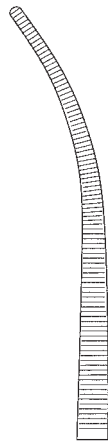

015-541-190
015-541-220
015-541-240



015-543-190
015-543-220
015-543-240

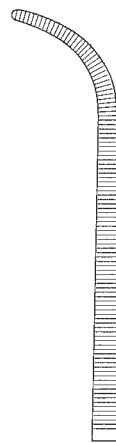

015-545-190
015-545-220
015-545-240

KELLY

015-541-190 - 015-545-190 19,0 cm / 7 1/2"
015-541-220 - 015-545-220 22,0 cm / 8 3/4"
015-541-240 - 015-545-240 24,0 cm / 9 1/2"



ZENKER

015-551-001 - 015-551-002 29,5 cm / 11 ⁵/₈"

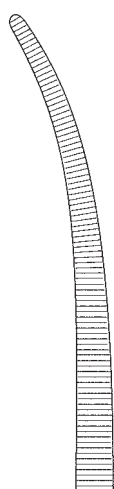

015-551-001

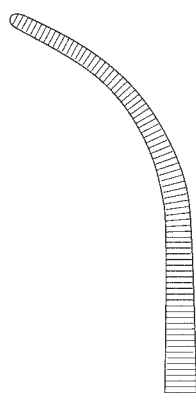

015-551-002



MEEKER

015-553-180 18,0 cm / 7"
015-553-275 27,5 cm / 10 ³/₄"

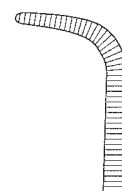

015-553-180

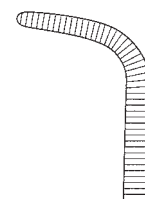

015-553-275



015

Klemmen
Forceps
Pinzas
Pinze

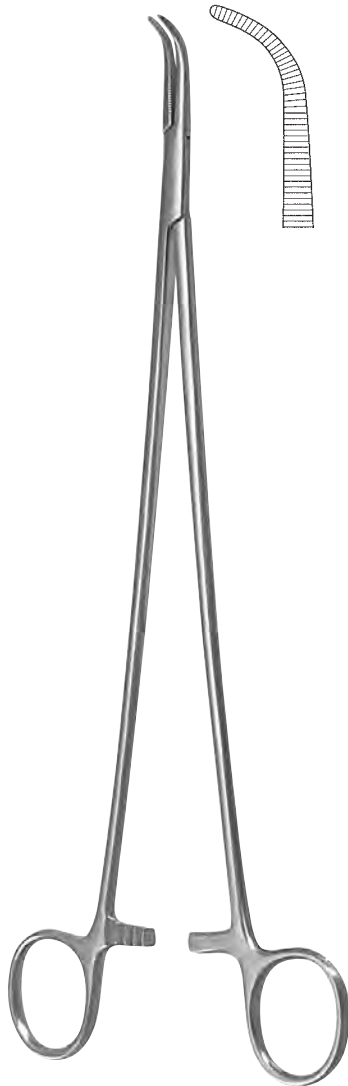

LAWRENCE

015-555-275 27,5 cm / 10³/₄"

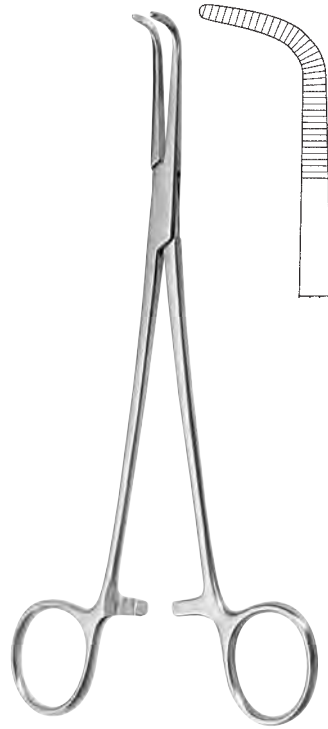

KANTROWITZ

015-561-190 19,0 cm / 7¹/₂"
015-561-240 24,0 cm / 9¹/₂"
015-561-265 26,5 cm / 10¹/₂"

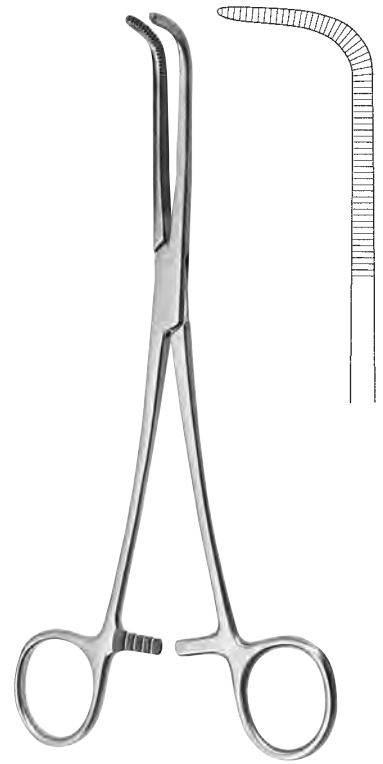

WIRKSTROEM

015-565-210 21,0 cm / 8¹/₄"
015-565-240 24,0 cm / 9¹/₂"

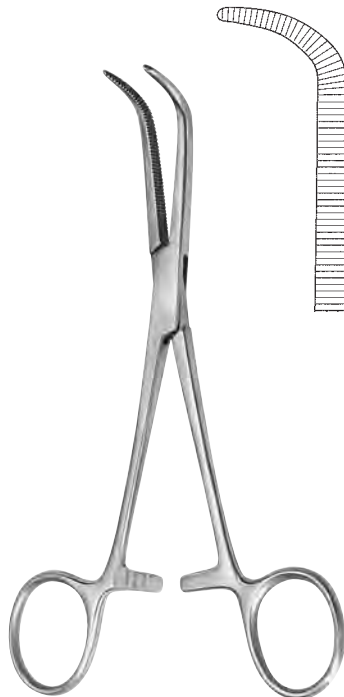

MIXTER

015-571-145 14,5 cm / 5³/₄"
015-571-155 15,5 cm / 6¹/₈"
015-571-190 19,0 cm / 7¹/₂"



MIXTER-O`SHAUGNESSY

015-575-155 15,5 cm / 6¹/₈"
015-575-190 19,0 cm / 7¹/₂"



MIXTER
 015-577-220 22,0 cm / 8³/₄"



MIXTER
 015-579-230 23,0 cm / 9"



DESJARDINS
 015-585-210 21,0 cm / 8¹/₄"



NEGUS
 015-587-190 - 015-589-190 19,0 cm / 7¹/₂"

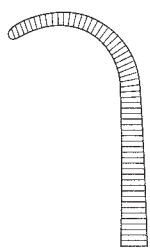

015-587-190

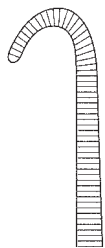

015-589-190

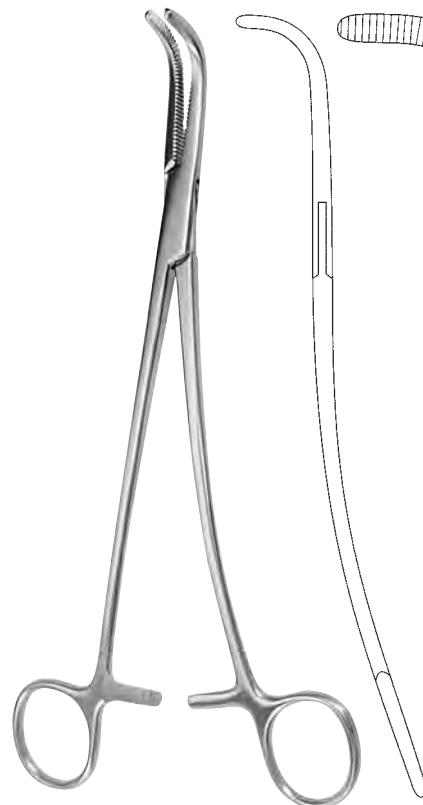

GRAY
 015-593-220 22,0 cm / 8³/₄"
 015-593-230 23,0 cm / 9"



015

Klemmen
Forceps
Pinzas
Pinze



015-601-220

015-601-250

015-601-280

MIXTER

015-601-220 22,0 cm / 8³/₄"
015-601-250 25,0 cm / 9³/₄"
015-601-280 28,0 cm / 11"



LOWER

015-603-180 18,0 cm / 7"



015-605-190

015-605-230

LAHEY

015-605-190 19,0 cm / 7¹/₂"
015-605-230 23,0 cm / 9"

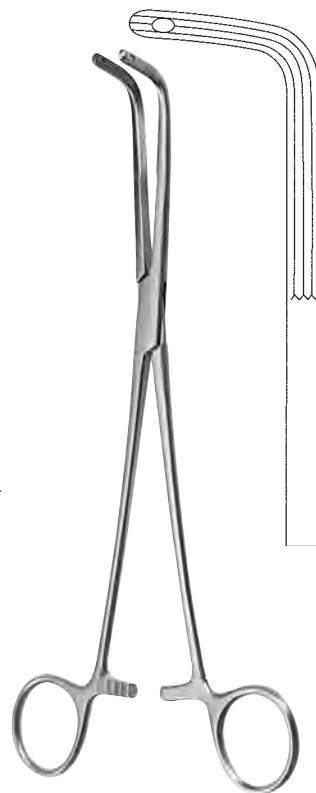

FINOCCHIETTO

015-607-240 24,0 cm / 9¹/₂"

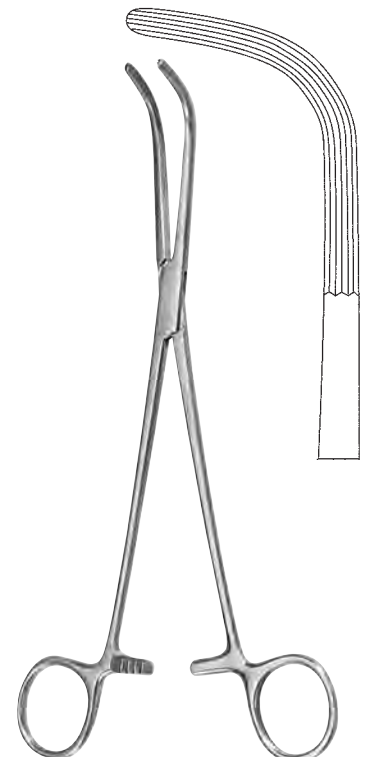

MC QUIGG-MIXTER

015-609-220 22,0 cm / 8³/₄"

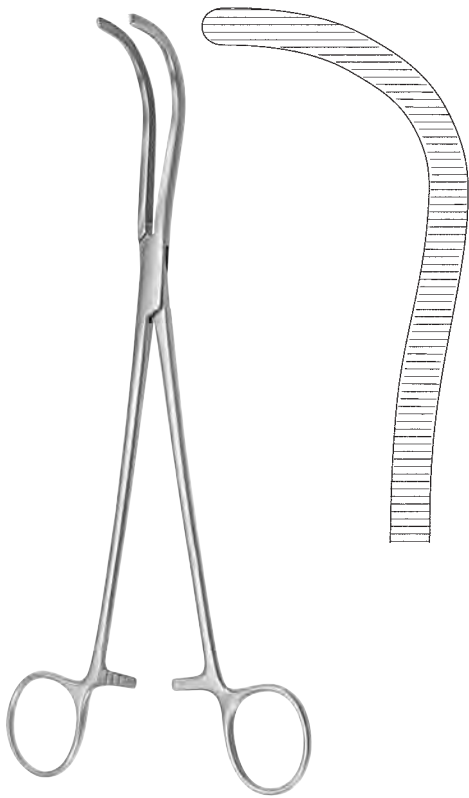

GUYON

015-621-230 23,0 cm / 12 1/2"



GUYON-ATRAUMA

015-627-230 23,0 cm / 9"

015-627-240 24,0 cm / 9 1/2"

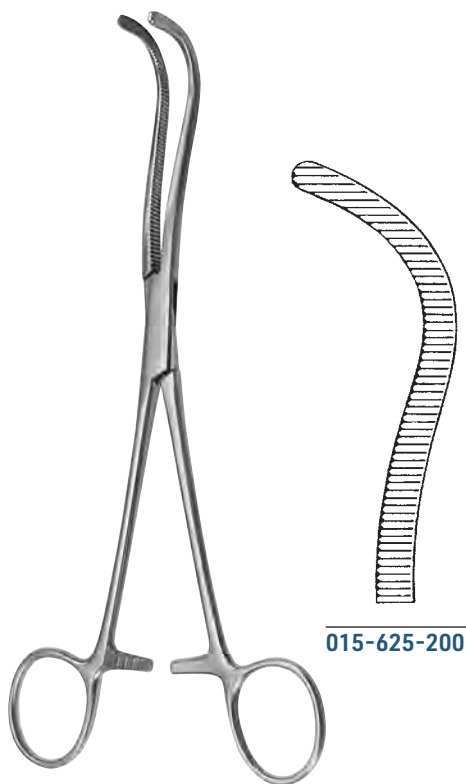

015-625-200

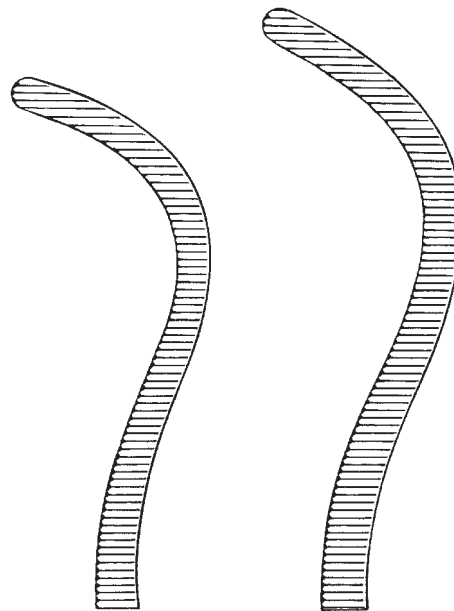

015-625-220

015-625-240

GUYON

015-625-200 20,0 cm / 8"

015-625-220 22,0 cm / 8 3/4"

015-625-240 24,0 cm / 9 1/2"



015

Klemmen
Forceps
Pinzas
Pinze

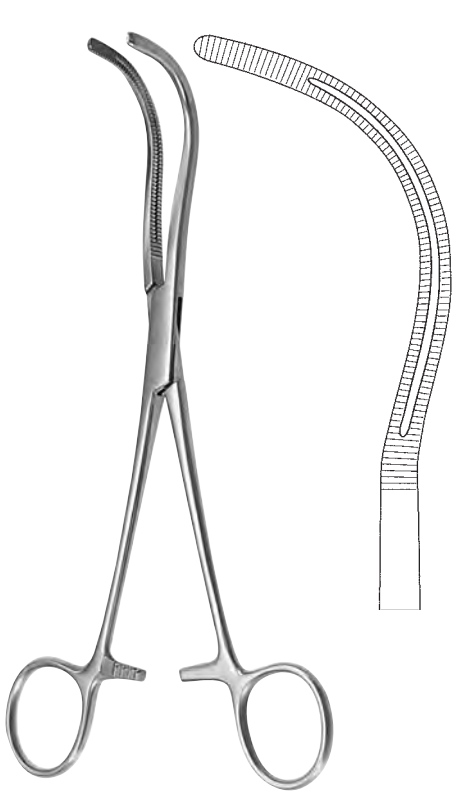

STILLE

015-631-230 23,0 cm / 9"

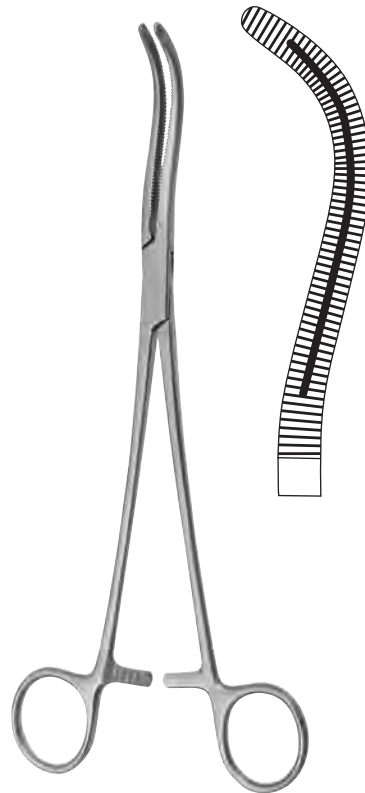

STILLE

015-633-230 23,0 cm / 9"

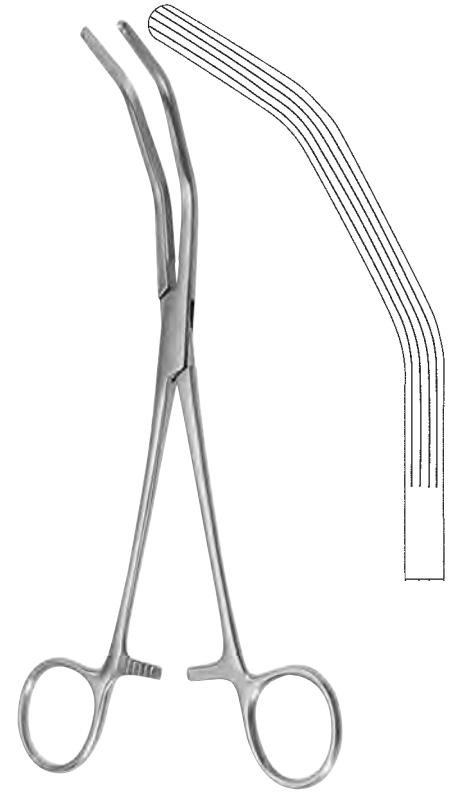

HERRICK

015-635-230 23,0 cm / 9"

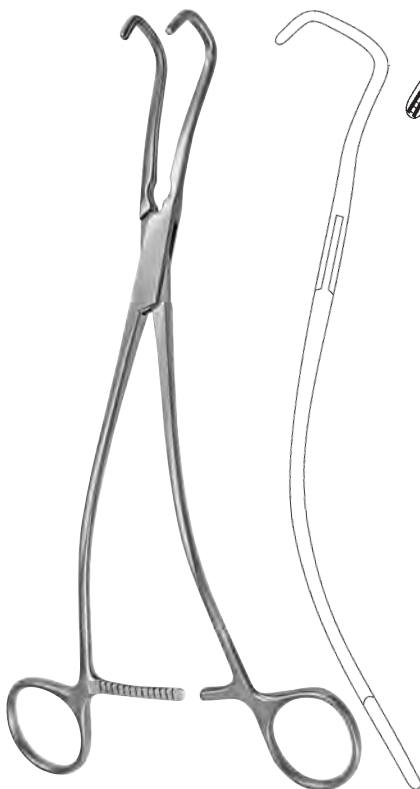

URO-TANGENTIAL

015-639-230 23,0 cm / 9"

015-639-240 24,0 cm / 9 1/2"

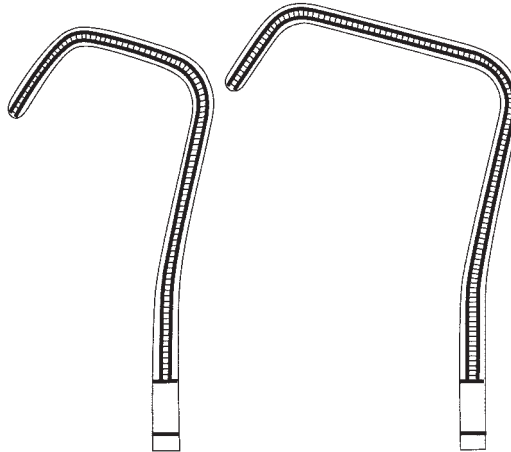

015-639-230

015-639-240

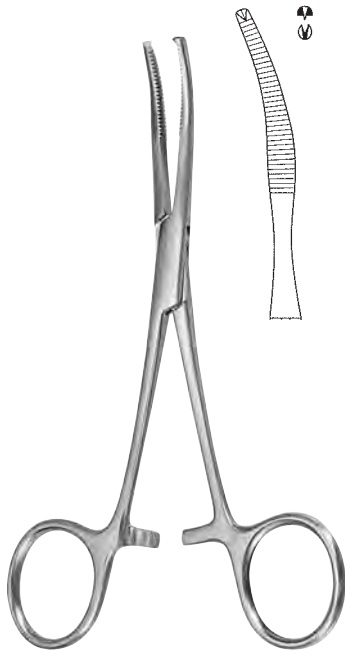

BABY-MIKULICZ
015-641-140 14,0 cm / 5³/₄"

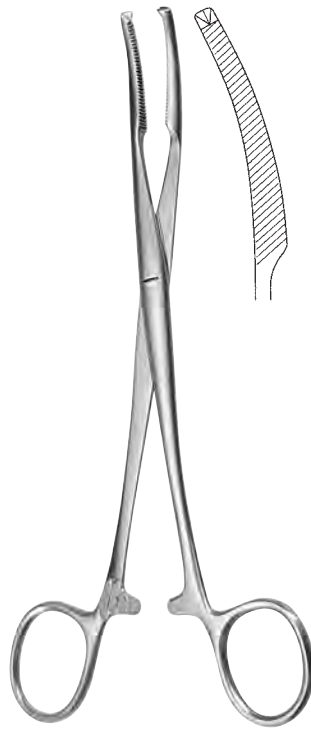

MIKULICZ
015-643-180 18,0 cm / 7"
015-643-200 20,0 cm / 8"



MIKULICZ
015-645-180 18,0 cm / 7"
015-645-200 20,0 cm / 8"

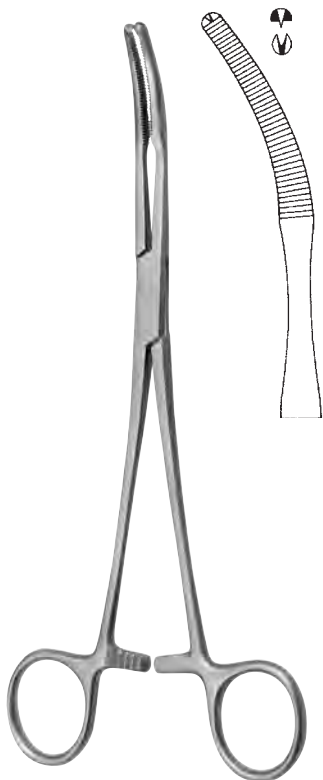

MIKULICZ
015-647-200 20,0 cm / 8"



MIKULICZ
015-649-205 20,5 cm / 8"



FAURE
015-651-200 - 015-653-200 20,0 cm / 8"

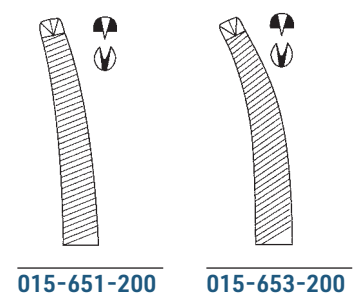



015

Klemmen
Forceps
Pinzas
Pinze

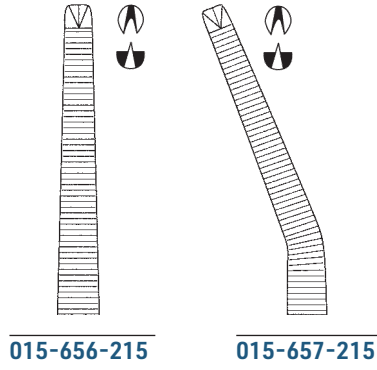

015-656-215

015-657-215

PHANEUF

015-656-215 - 015-657-215 21,5 cm / 8 1/2"

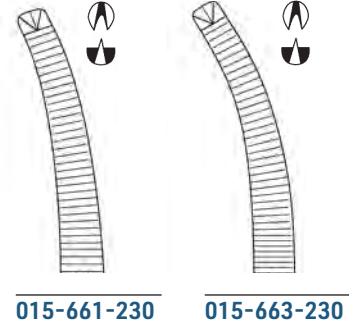

015-661-230

015-663-230

WERTHEIM

015-661-230 - 015-663-230 23,0 cm / 9"

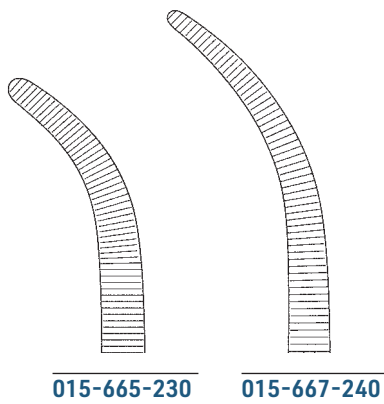

015-665-230

015-667-240

MOYNIHAN

015-665-230 23,0 cm / 9"
015-667-240 24,0 cm / 9 1/2"



WERTHEIM

015-669-250 25,0 cm / 10"



WERTHEIM-CULLEN
 015-671-215 21,5 cm / 8 1/2"

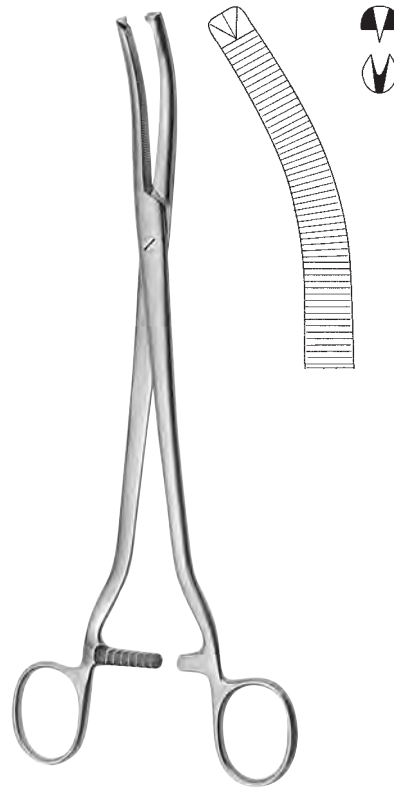

WERTHEIM
 015-671-240 24,0 cm / 9 1/2"



WERTHEIM
 015-673-235 23,5 cm / 9 1/4"



WERTHEIM
 015-675-235 23,5 cm / 9 1/4"

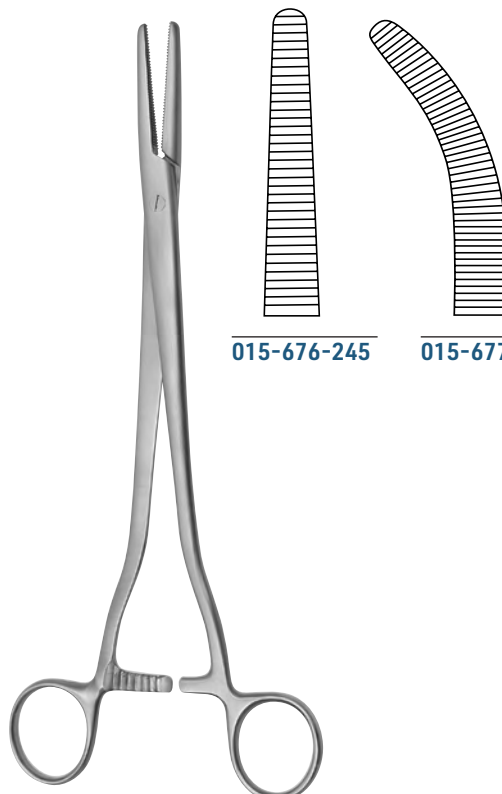

SEGOND-LANDAU
 015-676-245 24,5 cm / 9 2/3"
 015-677-240 24,0 cm / 9 1/2"

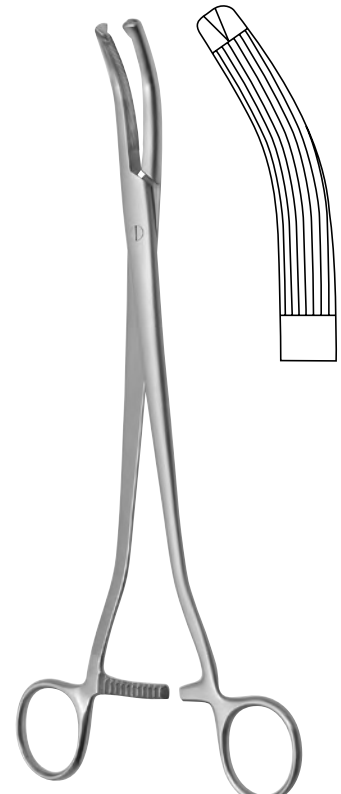

MIKULICZ
 015-679-245 24,5 cm / 9 2/3"



015

Klemmen
Forceps
Pinzas
Pinze

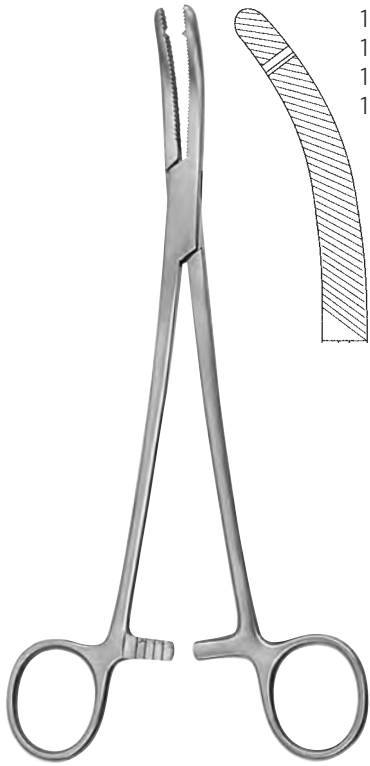

1 Zahn
1 tooth
1 diente
1 dente

HEANEY

015-681-195 19,5 cm / 7³/₄"
015-681-210 21,0 cm / 8¹/₄"
015-681-230 23,0 cm / 9"

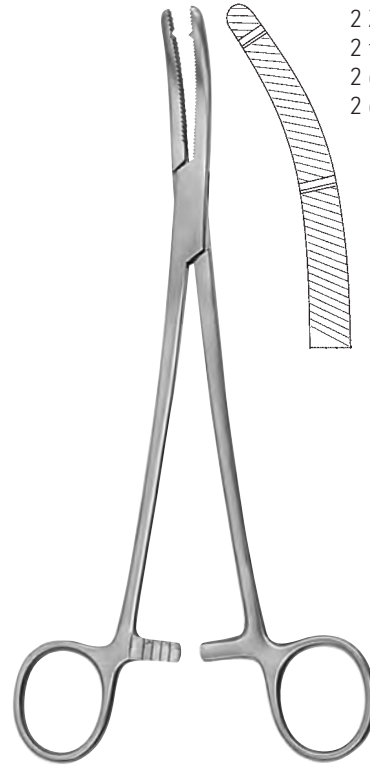

2 Zähne
2 teeth
2 dientes
2 denti

HEANEY

015-683-195 19,5 cm / 7³/₄"
015-683-210 21,0 cm / 8¹/₄"
015-683-230 23,0 cm / 9"



HEANEY-REZEK

015-684-210 21,0 cm / 8¹/₄"

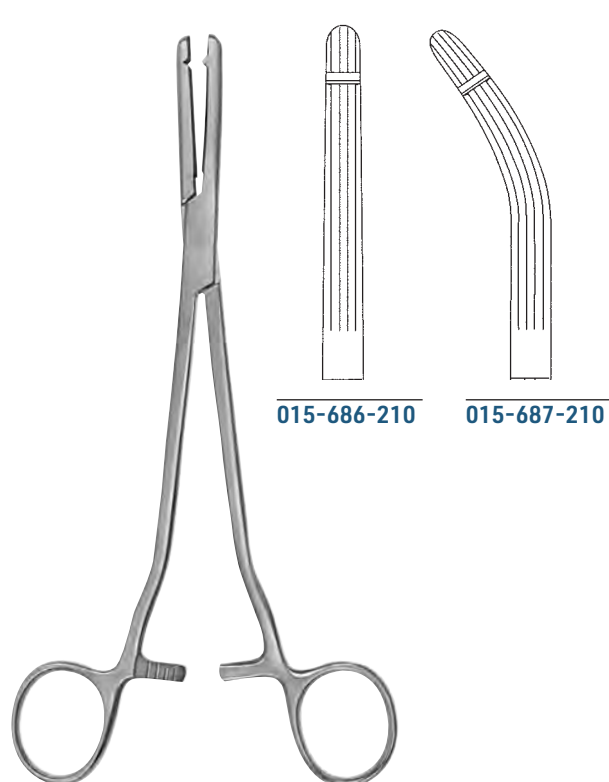

015-686-210

015-687-210

HEANEY-BALLENTINE

015-686-210 - 015-687-210 21,0 cm / 8¹/₄"

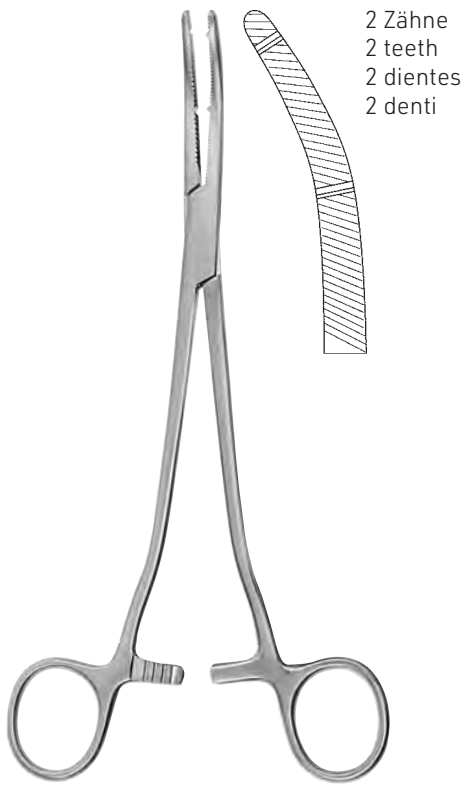

HEANEY-KANTER

015-689-210 21,0 cm / 8¹/₄"

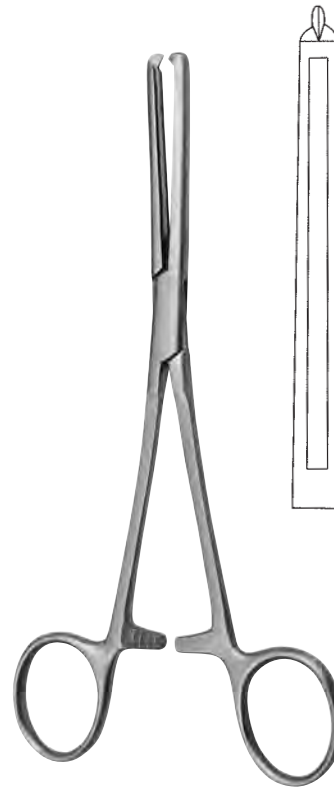

MAINGOT

015-690-200 20,0 cm / 8"

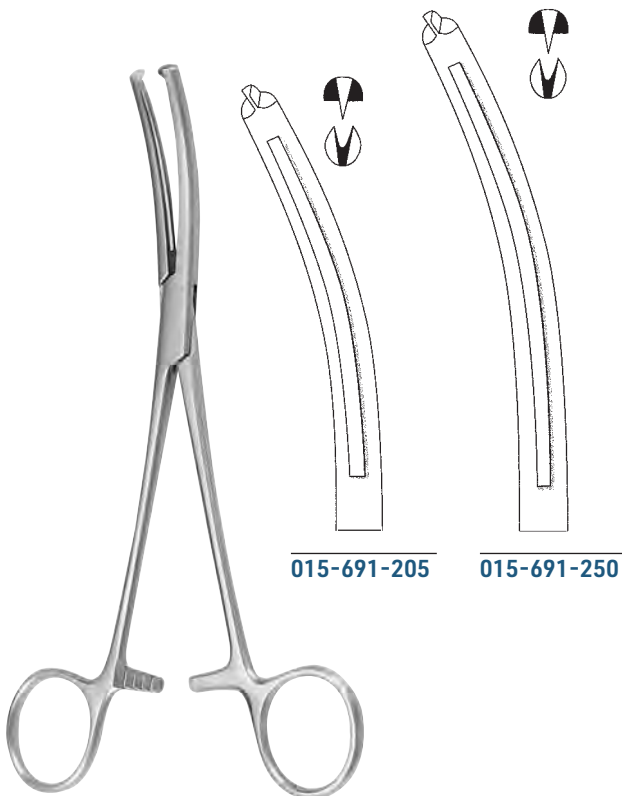

MAINGOT

015-691-205 20,5 cm / 8"

015-691-250 25,0 cm / 10"



015

Klemmen
Forceps
Pinzas
Pinze



015-693-001



015-693-002



015-693-003



015-693-004

ROGERS

015-693-001	21,5 cm / 8 ¹ / ₂ "
015-693-002	21,0 cm / 8 ¹ / ₄ "
015-693-003	20,5 cm / 8"
015-693-004	20,0 cm / 8"



015-695-001



015-695-002

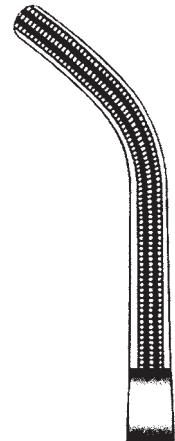

015-695-003

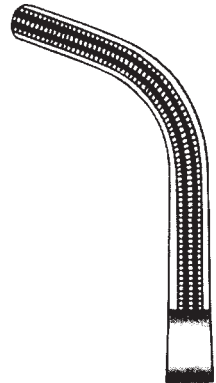

015-695-004

ROGERS

015-695-001	25,0 cm / 9 ³ / ₄ "
015-695-002	25,0 cm / 9 ³ / ₄ "
015-695-003	24,5 cm / 9 ² / ₃ "
015-695-004	23,0 cm / 9 ¹ / ₄ "



SCHAEDDEL

015-701-090 9,0 cm / 3 1/2"



ENGL. MODELL

015-703-090 9,0 cm / 3 1/2"



JONES

015-705-050 5,0 cm / 2"
015-705-090 9,0 cm / 3 1/2"

mit Schlauch- oder Kabelhalter
 with clip for tubing or cable
 con porta-tubo o porta-cable
 con porta-tubo o porta-cavo



mit Schlauchhalter
 with tube holder
 con porta-tubo
 con porta-tubo

JONES-FRIMED

015-707-090 9,0 cm / 3 1/2"

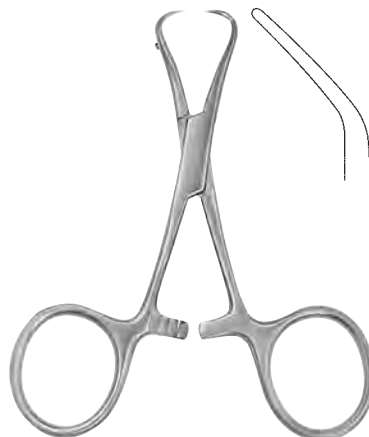

BACKHAUS

015-711-080 8,0 cm / 3 1/8"
015-711-110 11,0 cm / 4 3/8"
015-711-130 13,0 cm / 5 1/8"
015-711-150 15,0 cm / 6"



015-713-110 11,0 cm / 4 3/8"



015

Klemmen
Clamps
Pinzas
Pinze



ROEDER

015-715-130 13,0 cm / 5 1/8"
015-715-150 15,0 cm / 6"



LORNA

015-721-100 10,0 cm / 4"
015-721-130 13,0 cm / 5"

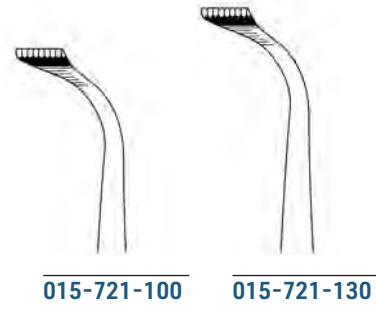

015-721-100

015-721-130



BERNHARD

015-724-165 16,5 cm / 6 1/2"



LANE

015-726-150 15,0 cm / 6"
015-726-180 18,0 cm / 7"
015-726-200 20,0 cm / 8"



BALL + SOCKET

015-731-115 11,5 cm / 4 1/2"
015-731-130 13,0 cm / 5 1/3"

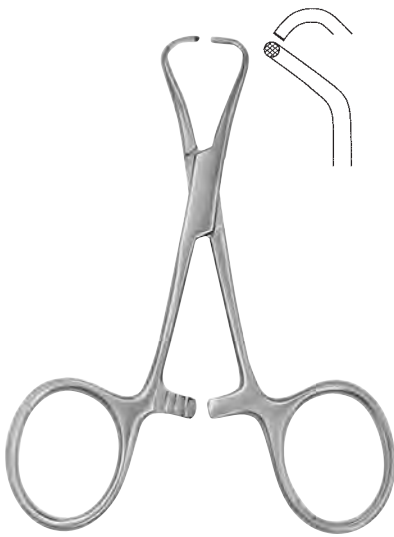

TOHOKU

015-733-100 10,0 cm / 4"
015-733-130 13,0 cm / 5¹/₃"

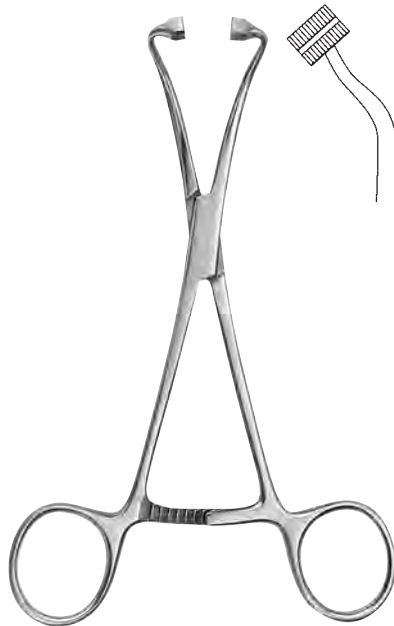

PEERS

015-735-145 14,5 cm / 5³/₄"



015-737-100 10,0 cm / 4"
015-737-130 13,0 cm / 5¹/₈"



HOFF

015-739-110 11,0 cm / 4³/₈"
015-739-145 14,5 cm / 5³/₄"



für Kabel bis Ø 5 mm
for cables up to Ø 5 mm
para cables hasta Ø 5 mm
per cavo fino a Ø 5 mm

ROBIN

015-741-135 13,5 cm / 5¹/₄"



für Schläuche bis Ø 13 mm
for tubes up to Ø 13 mm
para tubos hasta Ø 13 mm
per tubi fino a Ø 13 mm

ROBIN

015-743-135 13,5 cm / 5¹/₄"



015

Klemmen
Clamps
Pinzas
Pinze

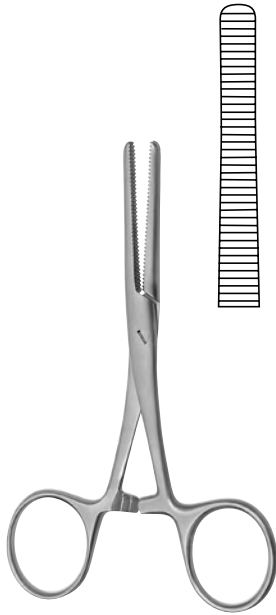

PEAN

015-750-125 12,5 cm / 5"



BERLIN

015-760-145 14,5 cm / 5³/₄"

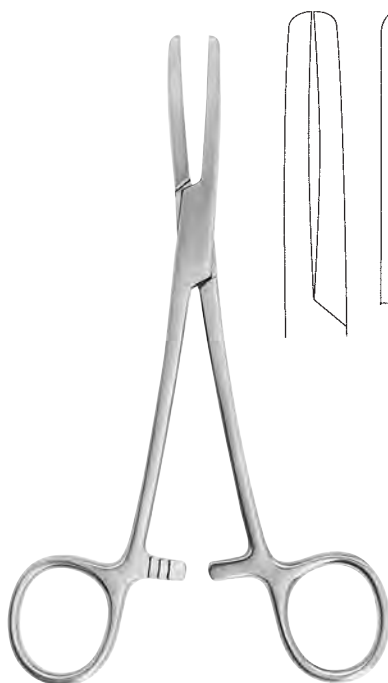

glatt
smooth
lisa
liscio

PRESBYTERIAN

015-770-160 16,0 cm / 6¹/₄"

015-770-180 18,0 cm / 7"

015-770-200 20,0 cm / 8"



015-780-155 15,5 cm / 6 1/8"
015-780-180 18,0 cm / 7"
015-780-200 20,0 cm / 8"



015-780-155

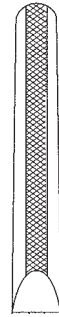

015-780-180

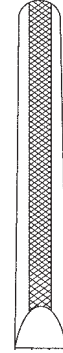

015-780-200



015-790-155 15,5 cm / 6 1/8"
015-790-180 18,0 cm / 7"
015-790-200 20,0 cm / 8"



015-790-155

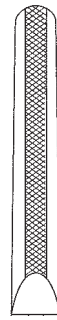

015-790-180

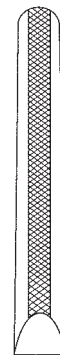

015-790-200

mit Schutzbügel
with safety guard
con estribo de protección
con protezione



015

Korn- und Tupferzangen
Sponge and Dressing Forceps
Pinzas para vendajes y torundas
Pinze per medicatura e tamponi



015-800-200
015-800-265

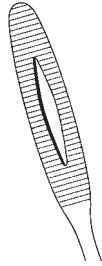

015-801-200
015-801-265

GROSS-MAIER

015-800-200 - 015-801-200 20,0 cm / 8"
015-800-265 - 015-801-265 26,5 cm / 10 1/2"



015-804-180

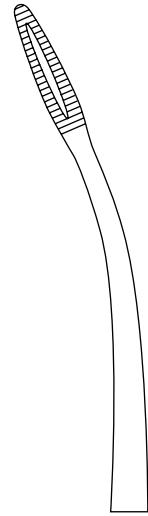

015-805-180

GROSS

015-804-180 - 015-805-180 18,0 cm / 7"



015-806-180

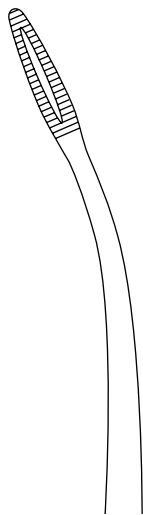

015-807-180

GROSS

015-806-180 - 015-807-180 18,0 cm / 7"

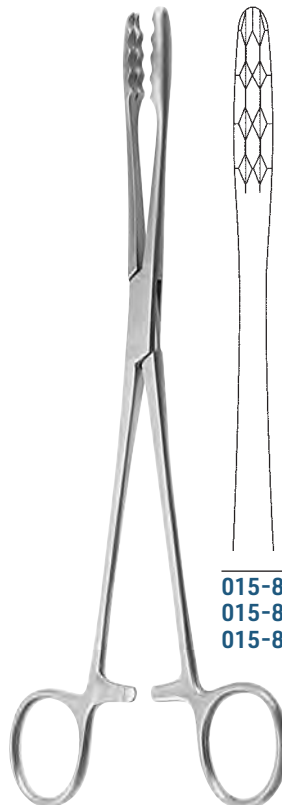

015-810-220
015-810-250
015-810-270



015-811-220
015-811-250
015-811-270

ULRICH

015-810-220 - 015-811-220 22,0 cm / 8 3/4"
015-810-250 - 015-811-250 25,0 cm / 9 3/4"
015-810-270 - 015-811-270 27,0 cm / 10 3/4"

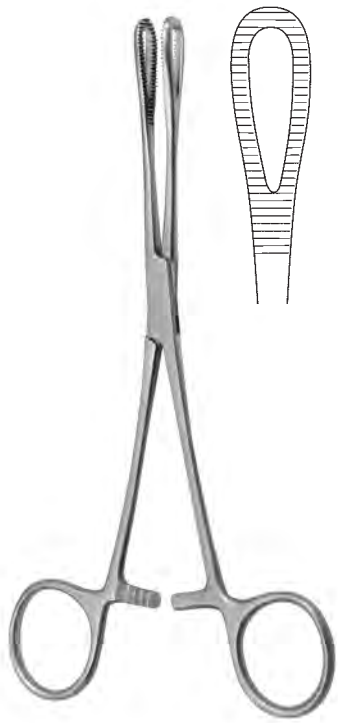

RAMPLEY

015-820-180 18,0 cm / 7"
015-820-250 25,0 cm / 9³/₄"

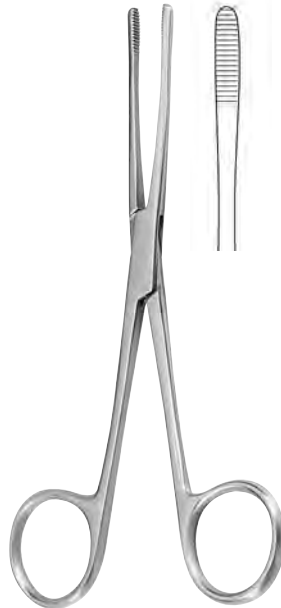

LISTER

015-830-130 13,0 cm / 5¹/₈"
015-830-160 16,0 cm / 6¹/₄"
015-830-180 18,0 cm / 7"



BRYANT

015-831-130 13,0 cm / 5¹/₈"



SIMS-MAIER

015-836-280 - 015-837-280 28,0 cm / 11"

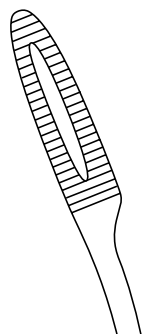

015-837-280

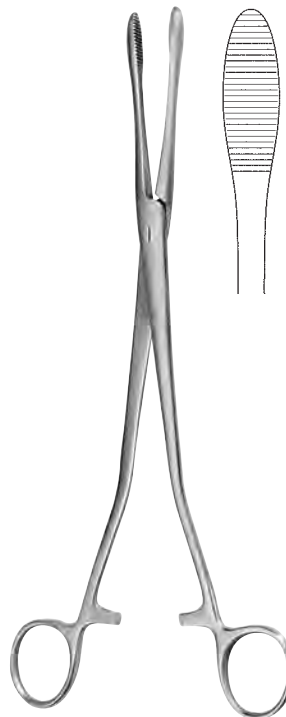

COLLIN

015-840-250 25,0 cm / 9³/₄"

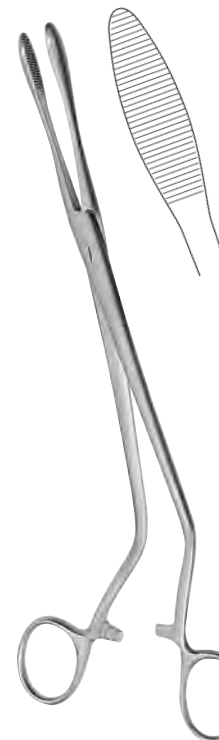

CHERON

015-841-250 25,0 cm / 9³/₄"



015

Korn- und Tupferzangen
Sponge and Dressing Forceps
Pinzas para vendajes y torundas
Pinze per medicatura e tamponi

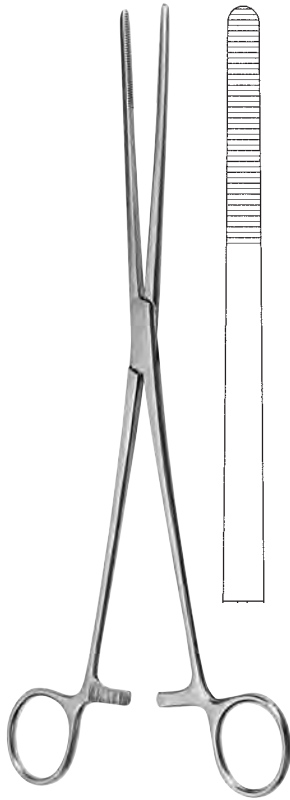

BOZEMANN
015-850-260 26,0 cm / 10¹/₄"

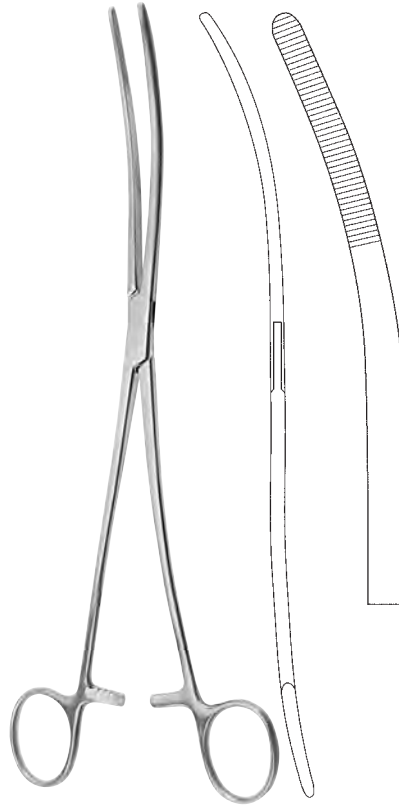

BOZEMANN
015-851-260 26,0 cm / 10¹/₄"

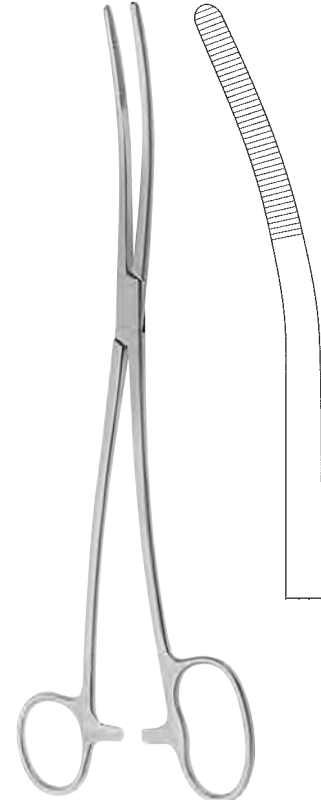

BOZEMANN-DOUGLAS
015-855-260 26,0 cm / 10¹/₄"



FOERSTER
015-860-180 - 015-871-180 18,0 cm / 7"
015-860-200 - 015-871-200 20,0 cm / 8"
015-860-250 - 015-871-250 25,0 cm / 9³/₄"

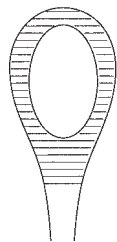

015-860-180
015-860-200
015-860-250

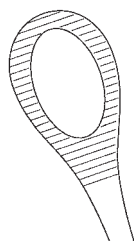

015-861-180
015-861-200
015-861-250



015-870-180
015-870-200
015-870-250

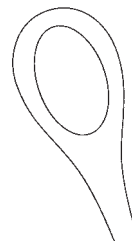

015-871-180
015-871-200
015-871-250

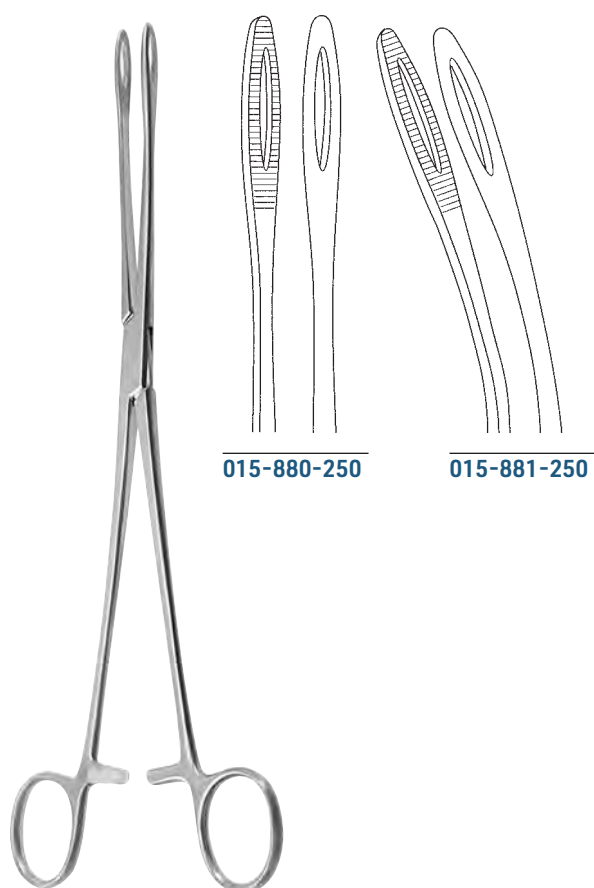

015-880-250

015-881-250

FOERSTER

015-880-250 - 015-881-250 25,0 cm / 9³/₄"

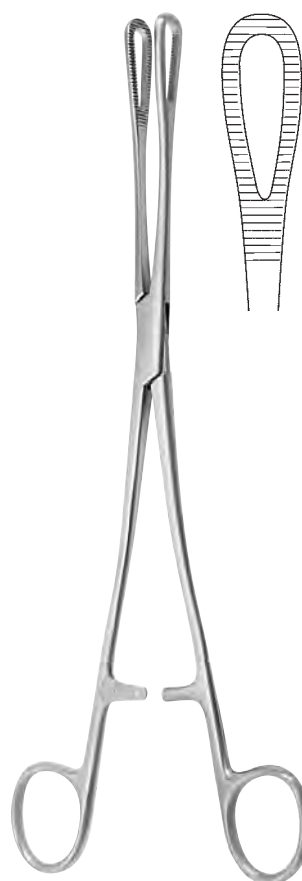

RAMPLEY

015-890-250 25,0 cm / 9³/₄"



015

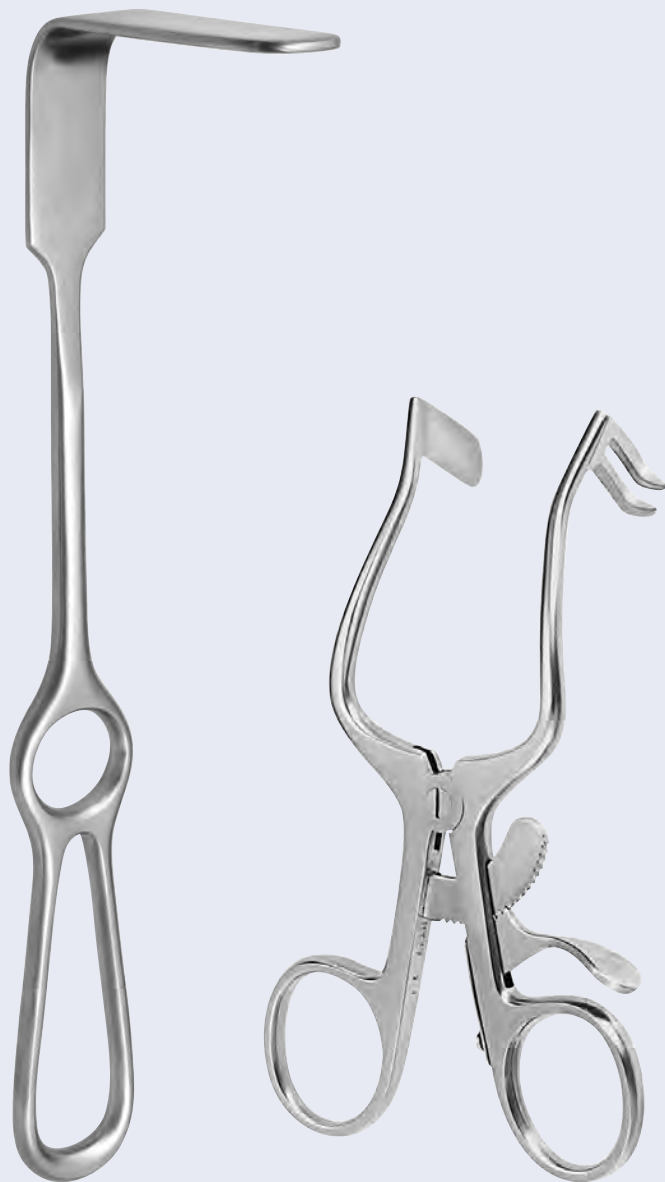

016

Wundhaken,
Wundspreizer,
Bauchdeckenhalter
Retractors, Self-retaining
Retractors, Abdominal
Retractors
Separadores, Separadores
autoestáticos,
Separadores abdominales
Divaricatori, Divaricatori
autostatici, Divaricatori
addominali



016

Wundhaken
Retractors
Separadores
Divaricatori

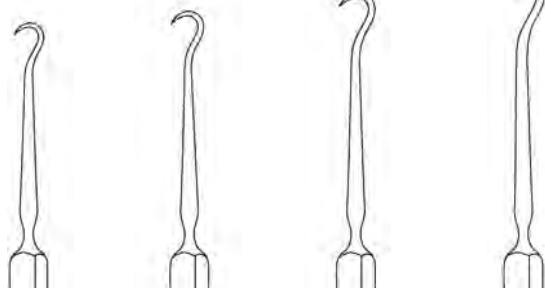

016-010-001 016-010-002 016-010-003 016-010-004

016-010-001 - 016-010-004 16,0 cm / 6¹/₄"

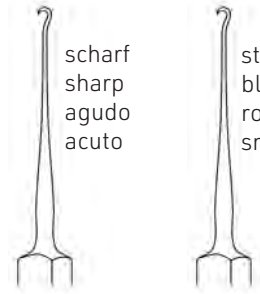

scharf
sharp
agudo
acuto

stumpf
blunt
romo
smusso

016-020-001 016-020-002

GRAEFE

016-020-001 - 016-020-002 15,0cm / 6"

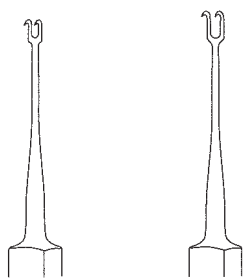

016-022-001 016-022-002

scharf
sharp
agudo
acuto

GUTHRIE

016-022-001 - 016-022-002 15,5 cm / 6¹/₄"



O`CONNOR

016-024-160 16,0 cm / 6¹/₄"

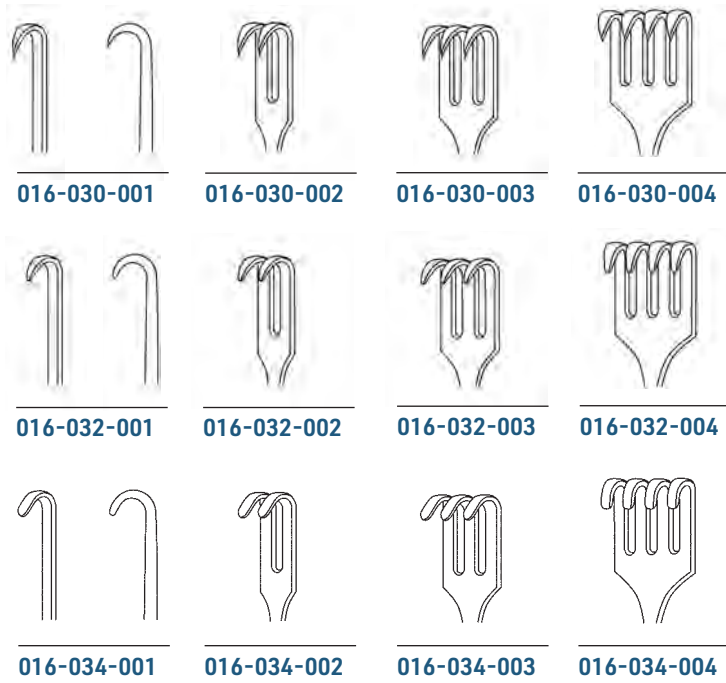

scharf
 sharp
 agudo
 acuto

halbscharf
 semi-sharp
 semi-agudo
 semi-acuto

stumpf
 blunt
 romo
 smusso

016-030-001 - 016-034-004 16,0 cm / 6 1/4"

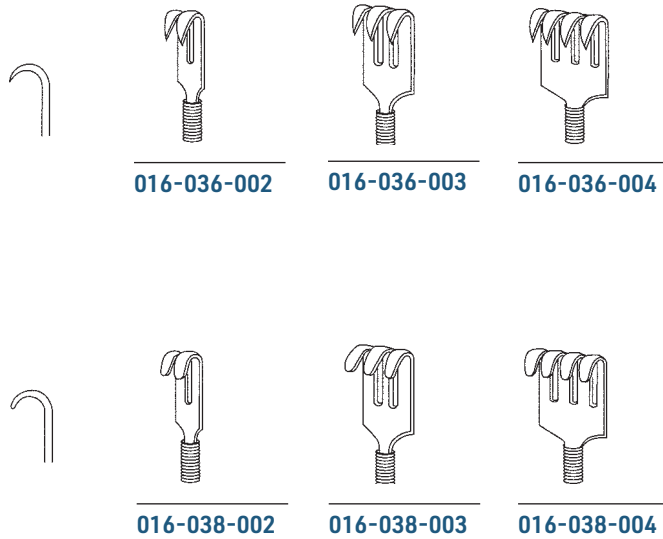

scharf
 sharp
 agudo
 acuto

stumpf
 blunt
 romo
 smusso

flexibel, flexible, flexibles, flessibili

016-036-002 - 016-038-004 16,0 cm / 6 1/4"



016

Wundhaken
Retractors
Separadores
Divaricatori



016-040-001 Fig.1

scharf
sharp
agudo
acuto



016-040-002 Fig.2

stumpf
blunt
romo
smusso



KNAPP

016-040-001 - 016-040-002 13,0 cm / 5"



DESMARRES

016-050-008 - 016-050-018 16,0 cm / 6 1/4"



016-050-008 8,0 mm



016-050-010 10,0 mm



016-050-012 12,0 mm

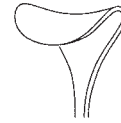

016-050-014 14,0 mm

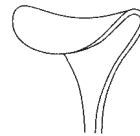

016-050-016 16,0 mm

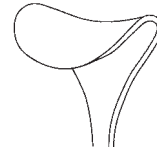

016-050-018 18,0 mm

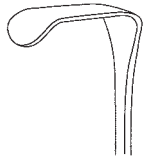

016-056-001 10x6 mm

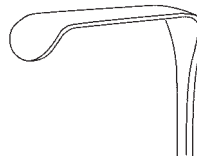

016-056-002 17x5 mm

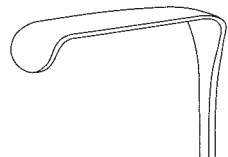

016-056-003 20x6 mm

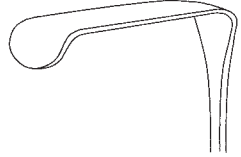

016-056-004 22x8 mm

MINI-LANGENBECK

016-056-001 - 016-056-004 16,0 cm, 6 1/4"



stumpf
 blunt
 romo
 smusso

16,0 cm, 6 1/4"

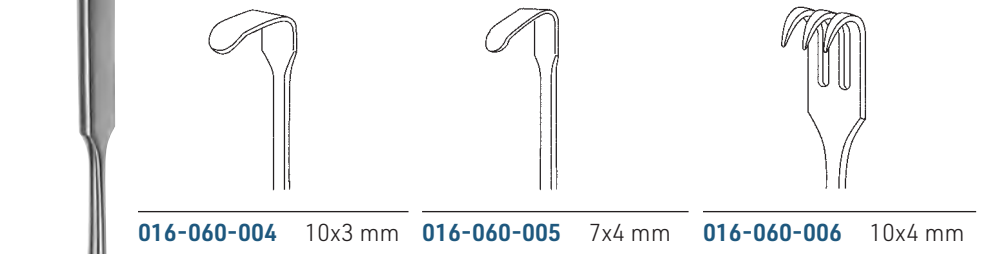
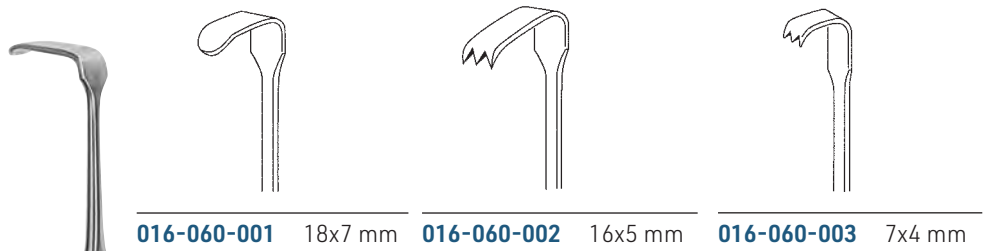

MEYERDING

016-060-001 - 016-060-006 16,0 cm / 6 1/4"

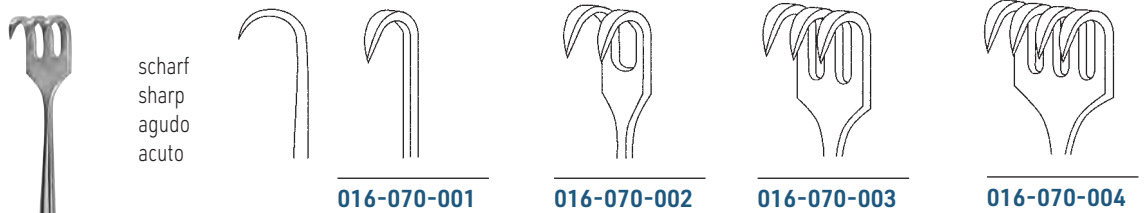

Kehlengriff
 serrated handle
 mango serrado
 manico striate



016-070-001 - 016-071-004 16,5 cm, 6 1/2"



016

Wundhaken
Retractors
Separadores
Divaricatori



016-072-001 16x6 mm

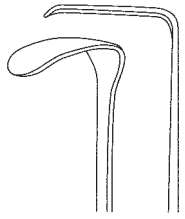

016-072-002 24x6 mm

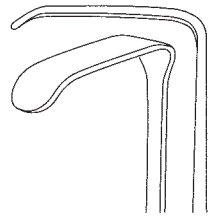

LANGENBECK-GREEN

016-072-001 - 016-072-002 15,0 cm / 6"



016-074-001 10x6 mm



016-074-002 20x6 mm

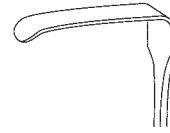

016-074-001 - 016-074-002 15,0 cm / 6"



RAGNELL-DAVIS

016-076-140 14,0 cm / 5 1/2"



RAGNELL

016-078-150 15,0 cm / 6"

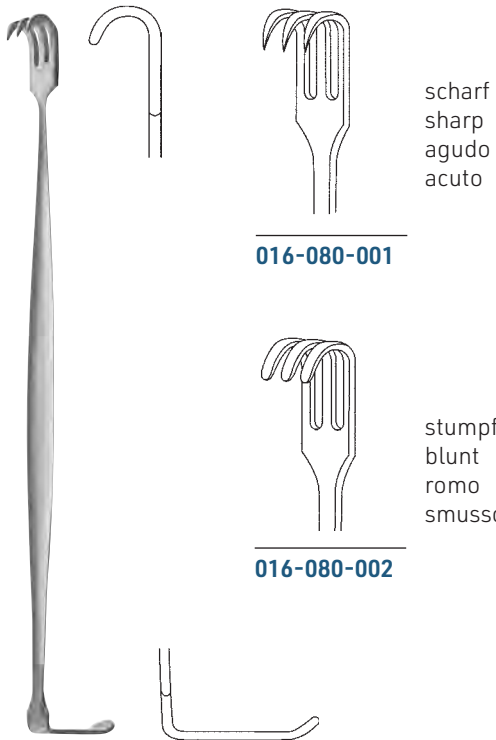

scharf
sharp
agudo
acuto

016-080-001

stumpf
blunt
romo
smusso

016-080-002

SENN-MILLER

016-080-001 - 016-080-002 16,0 cm / 6 1/4"

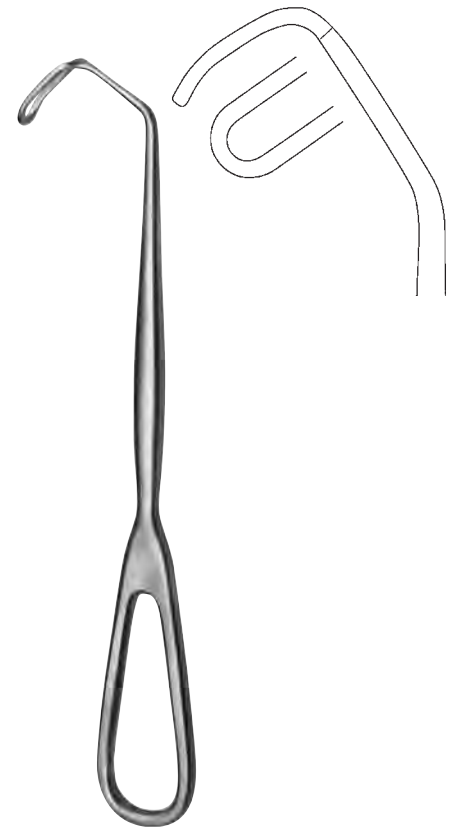

CUSHING

016-090-200 20,0 cm / 8"

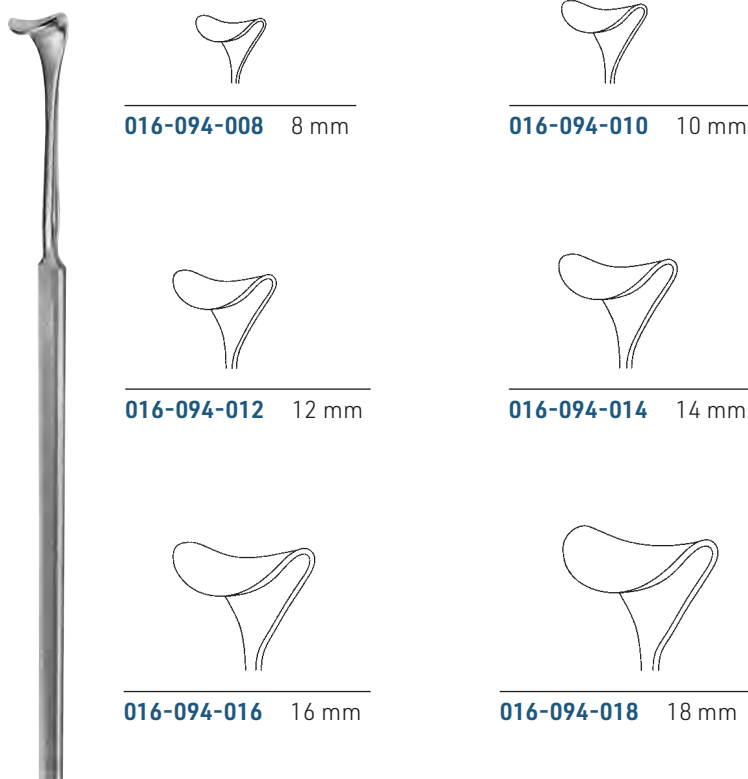

016-094-008 8 mm

016-094-010 10 mm

016-094-012 12 mm

016-094-014 14 mm

016-094-016 16 mm

016-094-018 18 mm

CUSHING

016-094-008 - 016-094-018 20,0 cm / 8"



016

Wundhaken
Retractors
Separadores
Divaricatori



016-096-008 8 mm



016-096-010 10 mm



016-096-012 12 mm



016-096-014 14 mm

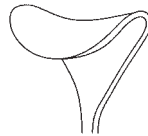

016-096-016 16 mm

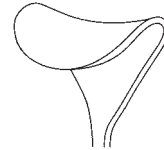

016-096-018 18 mm

CUSHING

016-096-008 - 016-096-018 24,0 cm / 9 1/2"

flexibel
 flexible
 flexibles
 flessibili



GIL-VERNET

016-100-008 - 016-100-023 24,0 cm / 9 1/2"

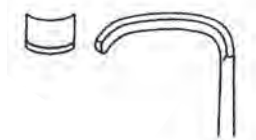

016-110-001

Fig. 1
 glatt
 smooth
 lisa
 liscio

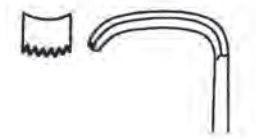

016-110-002

Fig. 2
 gezahnt
 toothed
 dentado
 dentate

STRANDELL-STILLE

016-110-001 - 016-110-002 19,0 cm / 7 1/2"



CUSHING

016-114-215 21,5 cm / 8 1/2"



016

Wundhaken
Retractors
Separadores
Divaricatori



016-120-001
scharf
sharp
agudo
acuto



016-120-002



016-120-003

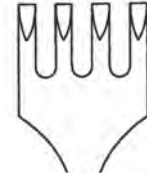

016-120-004

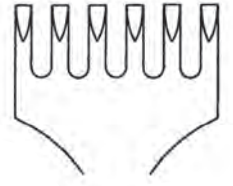

016-120-006

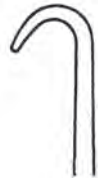

016-122-001
stumpf
blunt
romo
smusso



016-122-002



016-122-003



016-122-004

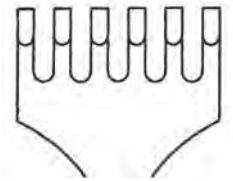

016-122-006

VOLKMANN

016-120-001 - 016-122-006 21,5 cm / 8 1/2"

scharf
sharp
agudo
acuto

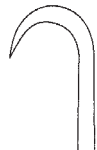

016-130-001

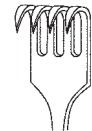

016-130-004 9x19 mm



016-130-002 9x8 mm

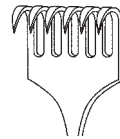

016-130-006 9x29 mm



016-130-003 9x13 mm

VOLKMANN

016-130-001 - 016-130-006 22,0 cm / 8 1/2"

halbscharf
 semi-sharp
 semi-agudo
 semi-acuto

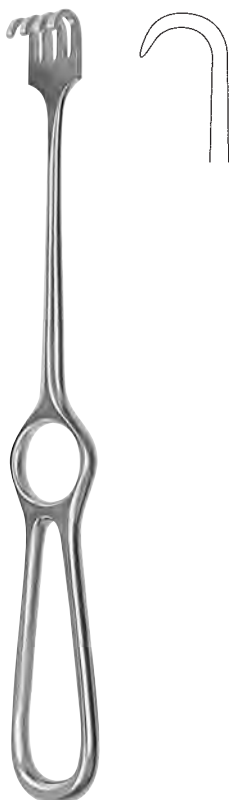

016-132-001



016-132-004 9x19 mm



016-132-002 9x8 mm

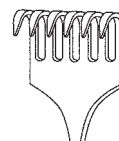

016-132-006 9x29 mm



016-132-003 9x13 mm

VOLKMANN

016-132-001 - 016-132-006 22,0 cm / 8³/₄"

stumpf
 blunt
 romo
 smusso

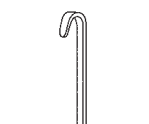
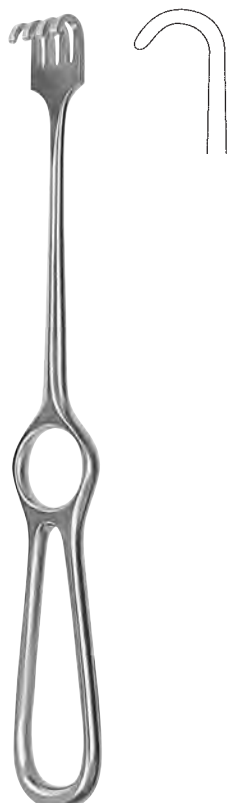

016-134-001



016-134-004 9x19 mm

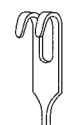

016-134-002 9x8 mm

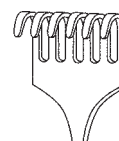

016-134-006 9x29 mm

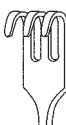

016-134-003 9x13 mm

VOLKMANN

016-134-001 - 016-134-006 22,0 cm / 8³/₄"



016

Wundhaken
Retractors
Separadores
Divaricatori

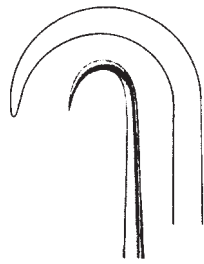

016-136-001
scharf
sharp
agudo
acuto

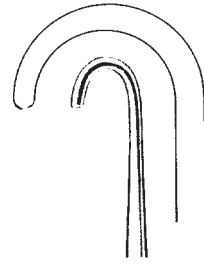

016-136-002
stumpf
blunt
romo
smusso

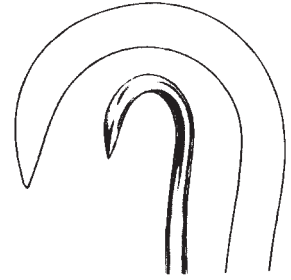

016-137-001
scharf
sharp
agudo
acuto

VOLKMANN

016-136-001 - 016-137-001 21,5 cm / 8 1/2"

scharf
sharp
agudo
acuto

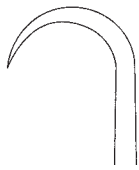

016-140-001



016-140-004 15x20 mm



016-140-002 9x8 mm

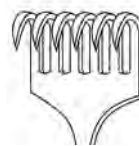

016-140-006 15x30 mm



016-140-003 15x15 mm

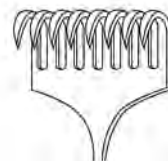

016-140-008 15x40 mm

KOCHER

016-140-001 - 016-140-008 22,0 cm / 8 5/8"

halbscharf
 semi-sharp
 semi-agudo
 semi-acuto



016-142-001



016-142-004 15x20 mm



016-142-002 9x8 mm

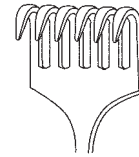

016-142-006 15x30 mm



016-142-003 15x15 mm

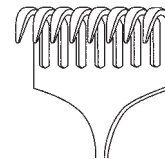

016-142-008 15x40 mm

KOCHER

016-142-001 - 016-142-008 22,0 cm / 8⁵/₈"

stumpf
 blunt
 romo
 smusso

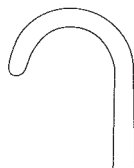

016-144-001

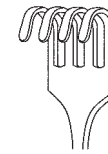
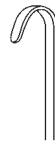

016-144-004 15x20 mm

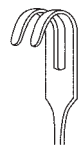

016-144-002 9x8 mm

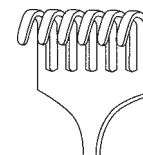

016-144-006 15x30 mm

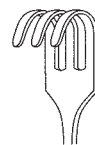

016-144-003 15x15 mm

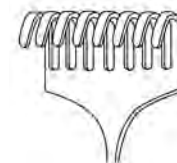

016-144-008 15x40 mm

KOCHER

016-144-001 - 016-144-008 22,0 cm / 8⁵/₈"



016

Wundhaken
Retractors
Separadores
Divaricatori



OLLIER

016-150-004 23,0 cm / 9" 36x60 mm

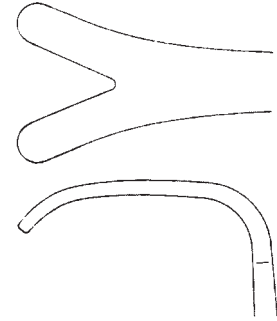

OLLIER

016-150-003 23,0 cm / 9" 36x30 mm

WASSMUND

016-155-002 20,5 cm / 8" 33x21 mm

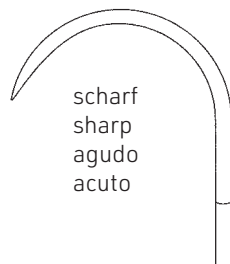

scharf
sharp
agudo
acuto

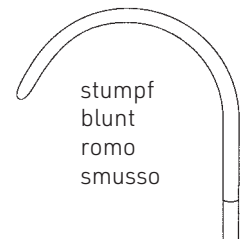

stumpf
blunt
rombo
smusso

KOERTE

016-160-008 24,0 cm / 9 1/2"

KOERTE

016-161-008 24,0 cm / 9 1/2"



stumpf
 blunt
 romo
 smusso

ISRAEL

016-166-040 - 016-166-070 25,0 cm / 9³/₄"

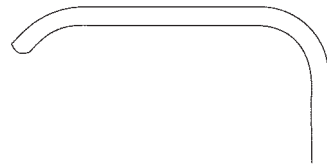

016-166-040 40x40 mm

4 Zähne
 4 teeth
 4 dientes
 4 denti

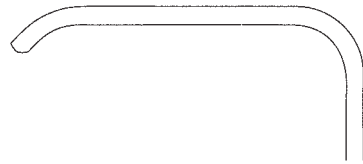

016-166-050 45x50 mm

5 Zähne
 5 teeth
 5 dientes
 5 denti



016-166-060 50x60 mm

6 Zähne
 6 teeth
 6 dientes
 6 denti



016-166-070 70x70 mm

6 Zähne
 6 teeth
 6 dientes
 6 denti

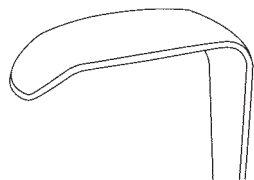

016-170-001 30x11 mm

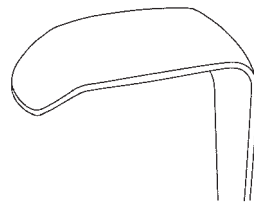

016-170-002 30x14 mm

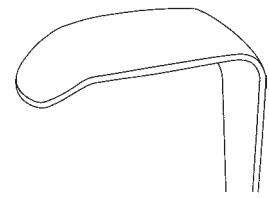

016-170-003 30x16 mm

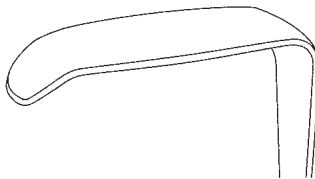

016-170-004 40x11 mm

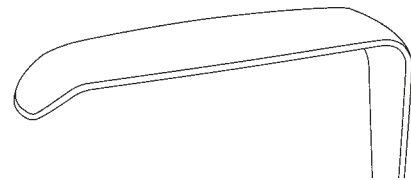

016-170-005 50x11 mm

LANGENBECK

016-170-001 - 016-170-005 22,5 cm / 9"



016

Wundhaken
Retractors
Separadores
Divaricatori

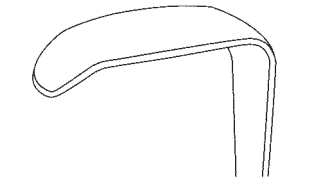

016-180-001 30x11 mm

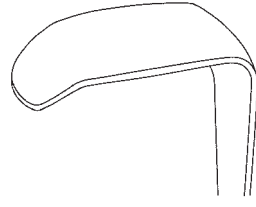

016-180-002 30x14 mm

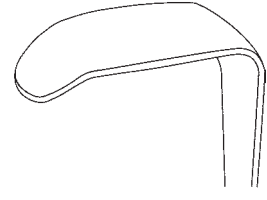

016-180-003 30x16 mm

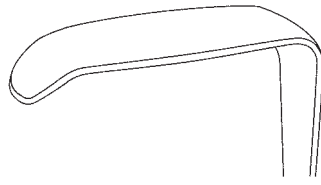

016-180-004 40x11 mm

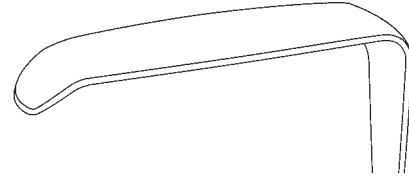

016-180-005 50x11 mm

LANGENBECK

016-180-001 - 016-180-005 22,0 cm / 8⁵/₈"



85x15 mm

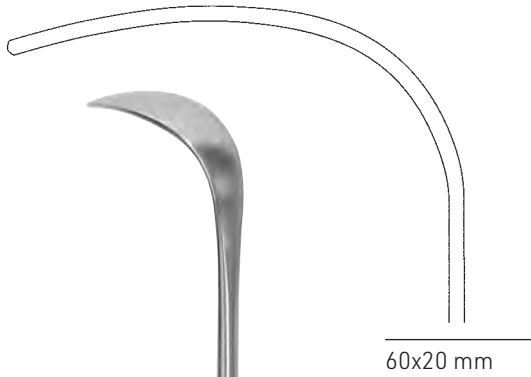

60x20 mm



LANGENBECK

016-182-210 21,0 cm / 8¹/₄"

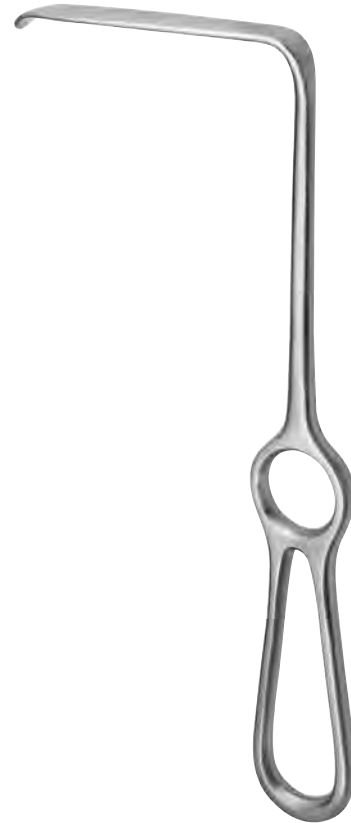

LANGENBECK

016-183-210 22,5 cm / 9"



LAHEY

016-190-190 19,0 cm / 7 1/2"



LITTLE

016-192-200 20,0 cm / 8"



016

Wundhaken
Retractors
Separadores
Divaricatori



KOCHER-LANGENBECK

016-200-001 - 016-200-010 21,5 cm / 8½"



016-200-001 25x6 mm



016-200-002 30x11 mm

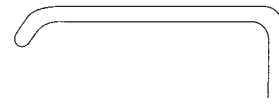

016-200-003 35x8 mm

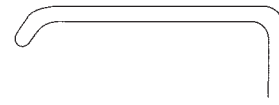

016-200-004 35x11 mm

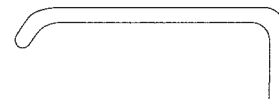

016-200-005 35x15 mm

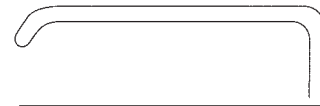

016-200-006 40x11 mm

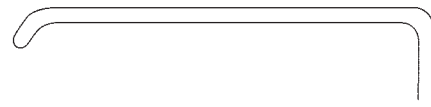

016-200-007 55x11 mm

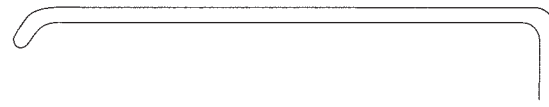

016-200-008 70x15 mm



016-200-009 80x12 mm



016-200-010 80x15 mm

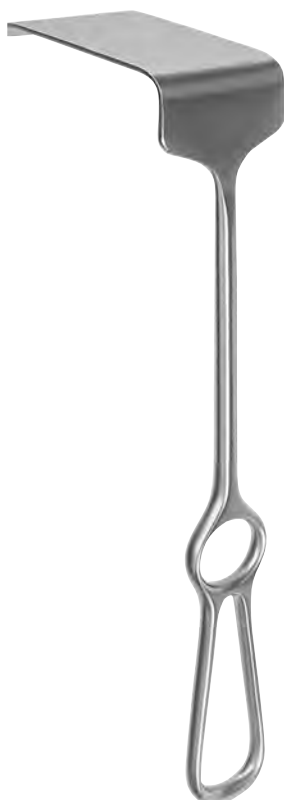

016-210-018 40x18 mm



016-210-020 60x20 mm



016-210-025 60x25 mm



016-210-030 75x30 mm

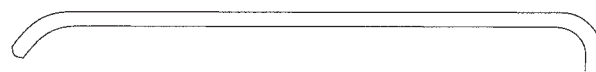

016-210-040 75x40 mm

KOCHER

016-210-018 - 016-210-040 21,0 cm / 8¹/₄"



016-220-001 50x15 mm

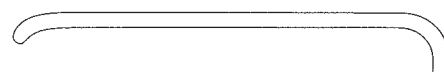

016-220-002 63x23 mm



016-220-003 80x20 mm

SAUERBRUCH

016-220-001 - 016-220-003 22,5 cm / 8³/₄"



016

Wundhaken
Retractors
Separadores
Divaricatori



ZENKER

016-230-001	25,0 cm / 9 ³ / ₄ "
016-230-002	26,0 cm / 10"
016-230-003	27,5 cm / 10 ³ / ₄ "

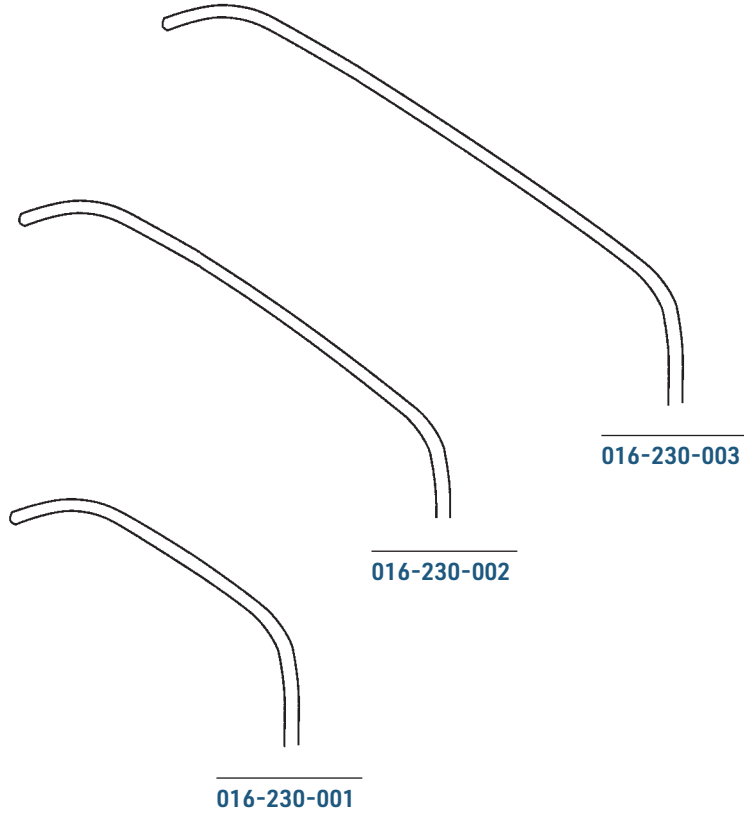

KOCHER

016-240-012	19,0 cm / 7 ¹ / ₂ "	19 x 12 mm
016-240-014	19,0 cm / 7 ¹ / ₂ "	21 x 14 mm



KOCHER

016-250-010	22 cm / 8 ⁵ / ₈ "	42x10 mm
016-250-015	22 cm / 8 ⁵ / ₈ "	42x15 mm
016-250-020	22 cm / 8 ⁵ / ₈ "	43x20 mm



016-260-001 18x17 mm

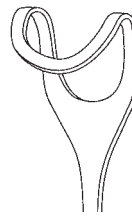

016-260-002 25x22 mm

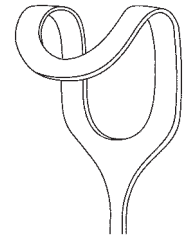

016-260-003 31x30 mm

MIDDELDORPF

016-260-001	21,5 cm / 8 ¹ / ₂ "
016-260-002	23,0 cm / 9"
016-260-003	24,5 cm / 9 ² / ₃ "



016-262-001 14x17 mm

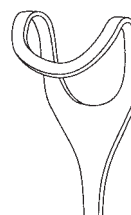

016-262-002 20x22 mm

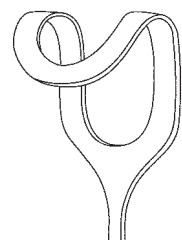

016-262-003 26x30 mm

MIDDELDORPF

016-262-001	21,5 cm / 8 ¹ / ₂ "
016-262-002	22 cm / 8 ⁵ / ₈ "
016-262-003	23,5 cm / 9 ¹ / ₂ "



016

Wundhaken
Retractors
Separadores
Divaricatori



RICHARDSON-EASTMAN

- 016-270-000** Fig. 1+2 27,0 cm / 10³/₄"
- 016-270-001** Fig. 1 26,0 cm / 10¹/₄"
- 016-270-002** Fig. 2 27,0 cm / 10³/₄"



RICHARDSON

- 016-272-001 - 016-272-004** 24,0 cm / 9¹/₂"

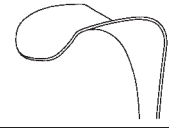

016-272-001 30x21 mm

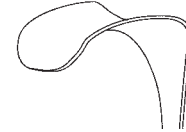

016-272-002 37x29 mm

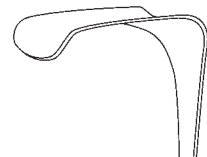

016-272-003 45x40 mm

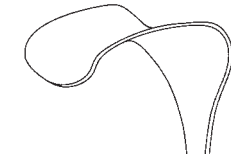

016-272-004 53x22 mm

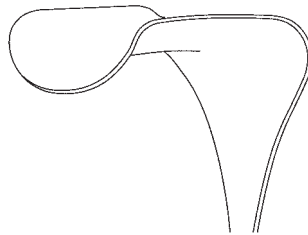

KELLY

- 016-274-001** 26,0 cm / 10¹/₄" 62 x 50 mm

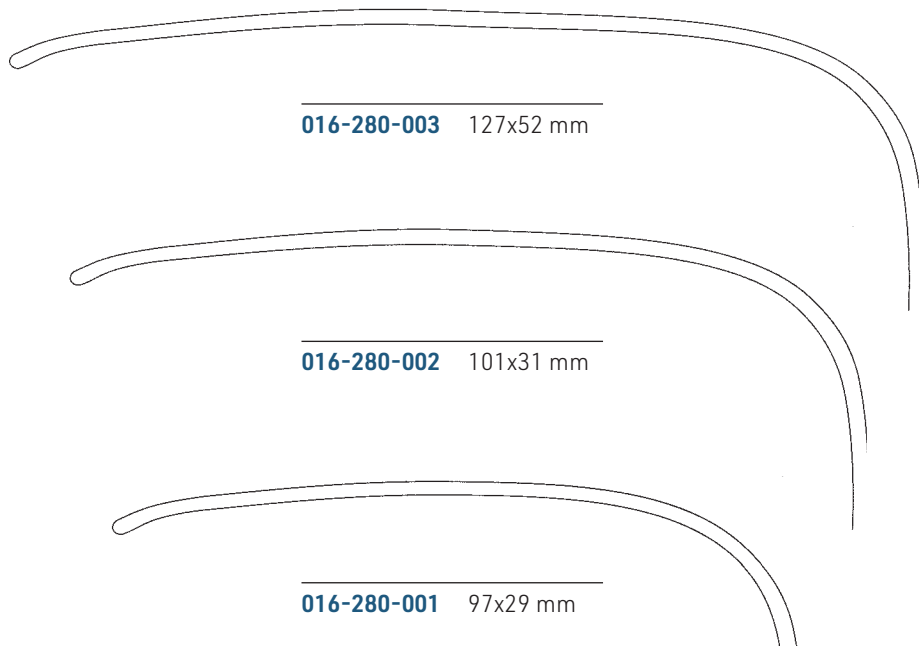
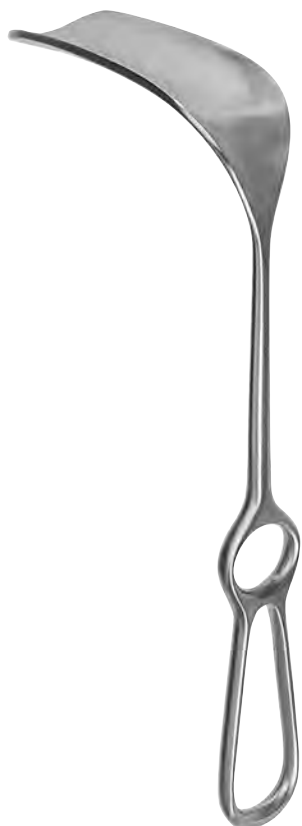

016-280-003 127x52 mm

016-280-002 101x31 mm

016-280-001 97x29 mm

DOYEN-STILLE

016-280-001 - 016-280-003 26,0 cm / 10¹/₄"

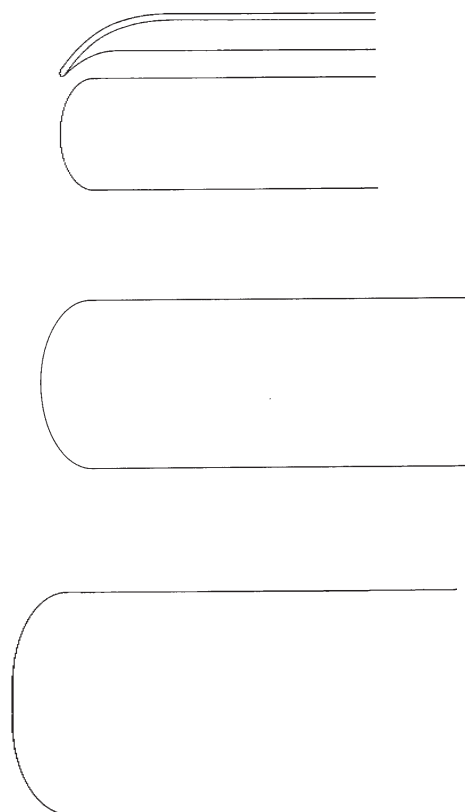
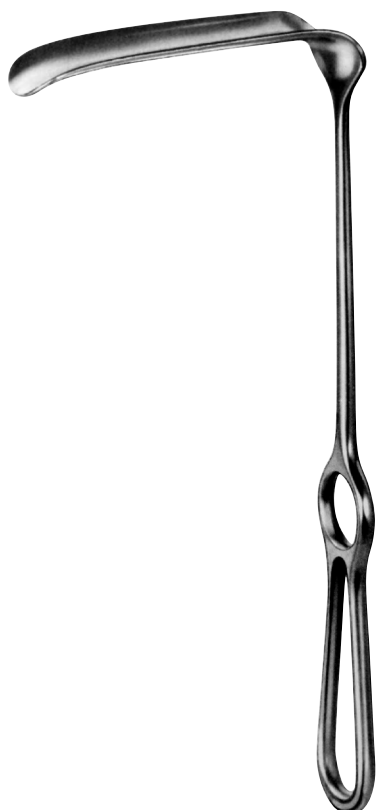

016-290-001 63x21 mm

016-290-002 83x30 mm

016-290-003 103x30 mm

016-290-004 120x30 mm

016-290-005 140x30 mm

016-290-006 140x40 mm

HÖSEL

016-290-001 - 016-290-006 26,0 cm / 10¹/₄"



016

Wundhaken
Retractors
Separadores
Divaricatori

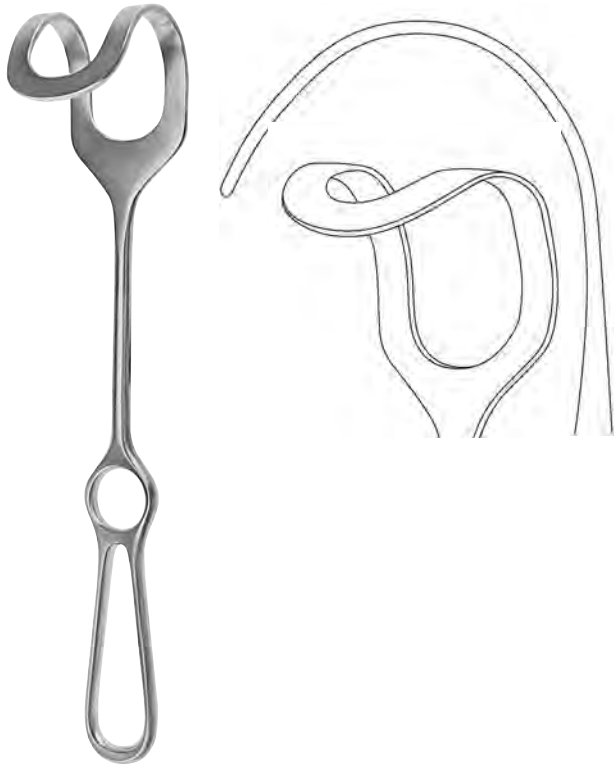

MIDDELDORPF

016-300-001	27,0 cm / 10 ³ / ₄ "	48x45 mm
016-300-002	27,0 cm / 10 ³ / ₄ "	52x50 mm
016-300-003	28,0 cm / 11"	60x70 mm



FRITSCH

016-310-000	23,5 cm / 9 ¹ / ₄ "	30x30 mm
016-310-001	24,0 cm / 9 ¹ / ₂ "	32x40 mm
016-310-002	25,0 cm / 9 ³ / ₄ "	40x50 mm
016-310-003	25,0 cm / 9 ³ / ₄ "	40x60 mm
016-310-004	25,5 cm / 10"	45x75 mm
016-310-005	26,5 cm / 10 ¹ / ₂ "	65x85 mm



DOYEN

016-320-250	25,0 cm / 10"
--------------------	---------------

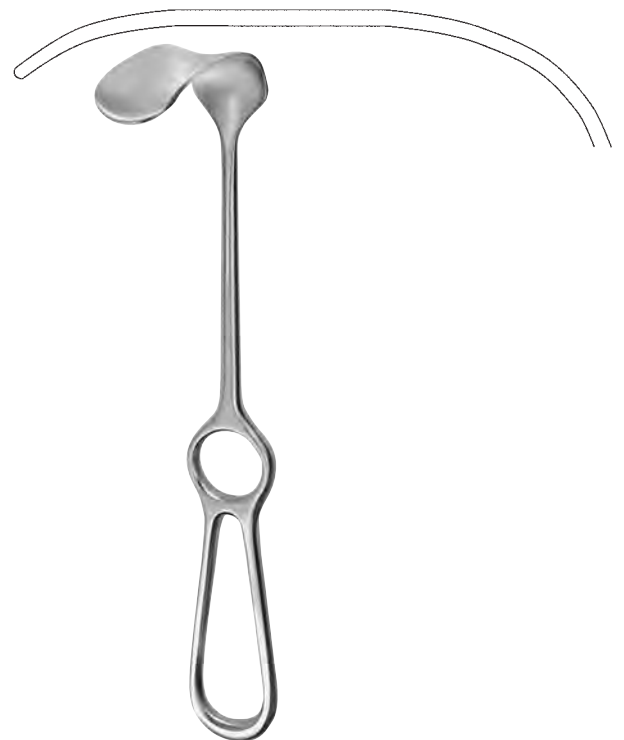

KOCHER

016-324-025	25,0 cm / 10"	70x25 mm
016-324-045	25,0 cm / 10"	80x45 mm
016-324-055	25,0 cm / 10"	80x55 mm
016-324-065	25,0 cm / 10"	80x65 mm

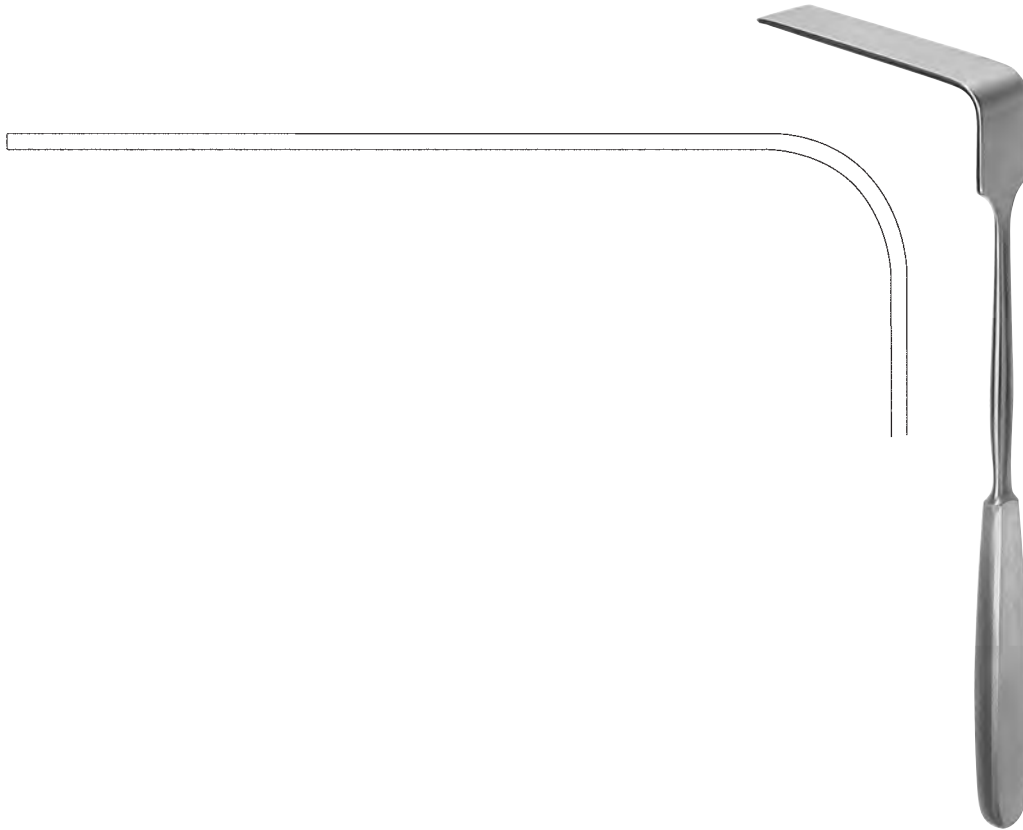

SIMON

016-326-022	28,0 cm / 11"	115x22 mm
016-326-027	28,0 cm / 11"	115x27 mm

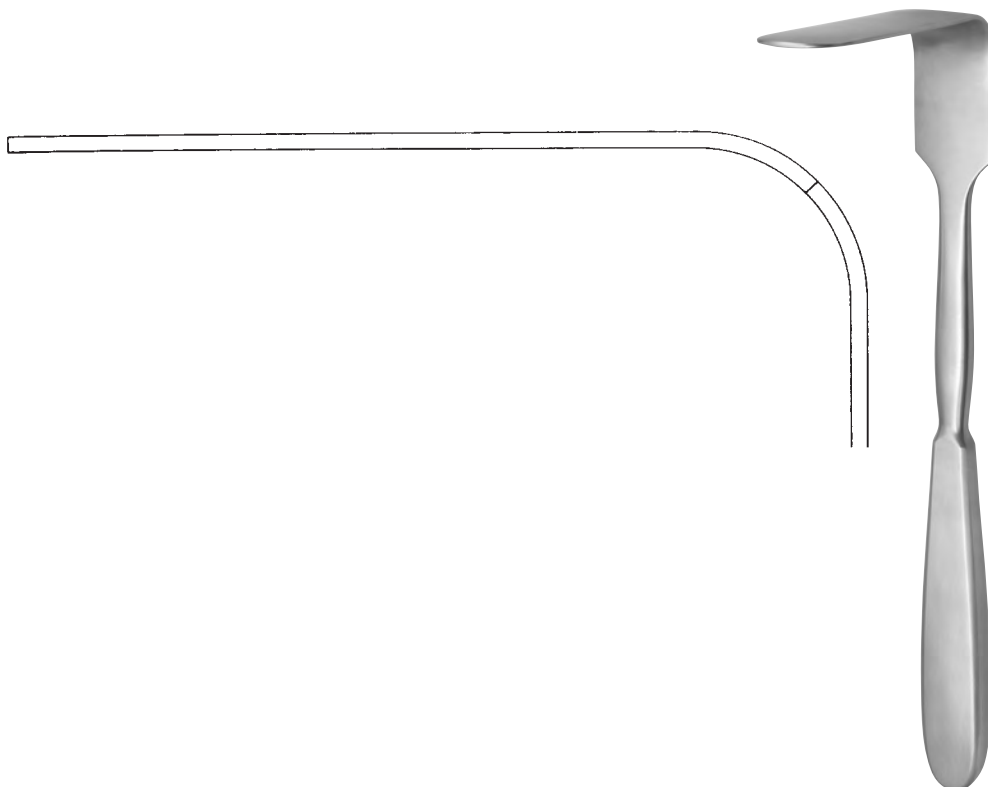

MARTIN

016-328-027	26,0 cm / 10"	110 x 27 mm
--------------------	---------------	-------------



016

Wundhaken
Retractors
Separadores
Divaricatori

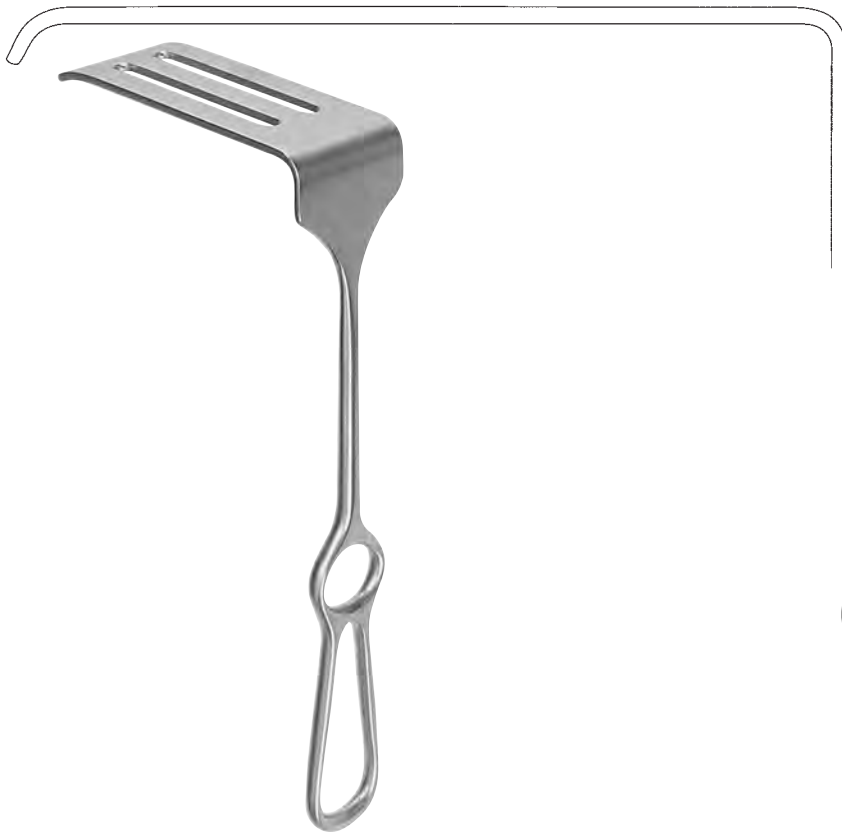

CORYLLOS

016-330-001	24,0 cm / 9 ¹ / ₂ "	85x22 mm
016-330-002	24,0 cm / 9 ³ / ₄ "	108x43 mm
016-330-003	24,0 cm / 9 ³ / ₄ "	119x65 mm

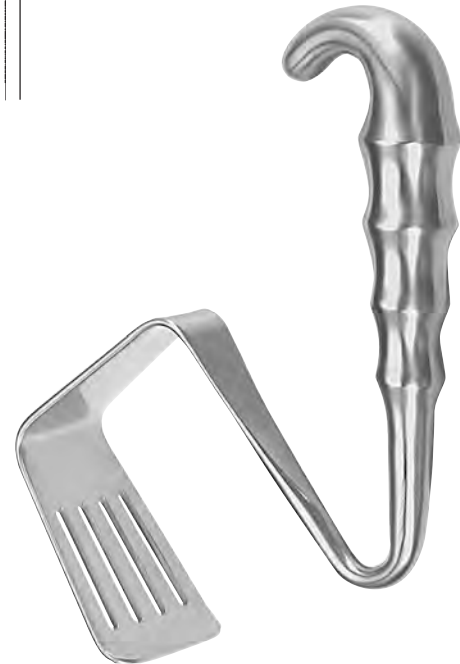

DAVIDSON

016-340-001	19,0 cm / 6 ¹ / ₄ "	80x54 mm
016-340-002	18,5 cm / 6 ¹ / ₄ "	80x95 mm



SAUERBRUCH

016-344-250	25,5 cm / 10"	127x38 mm
--------------------	---------------	-----------

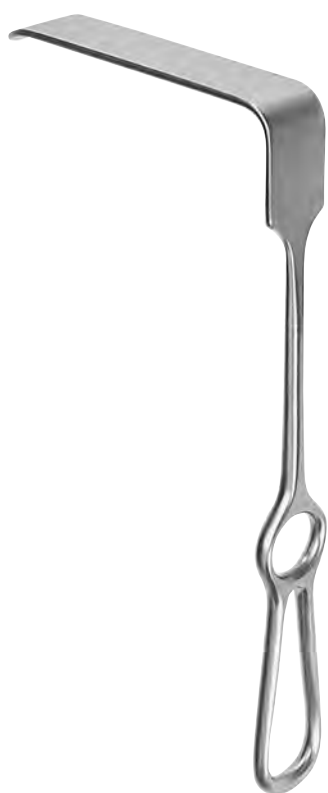
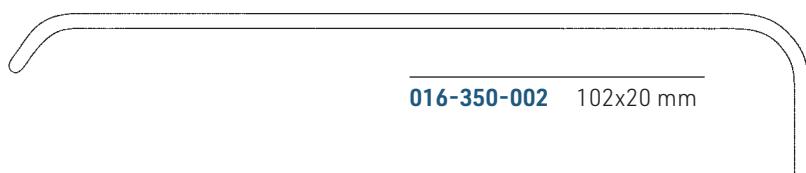
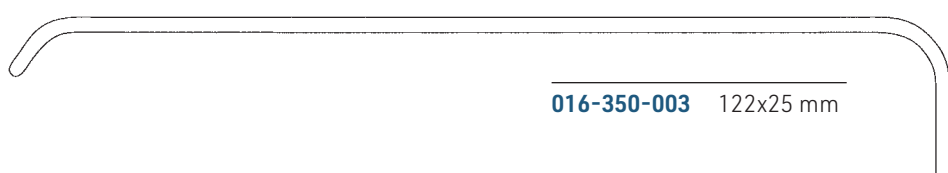
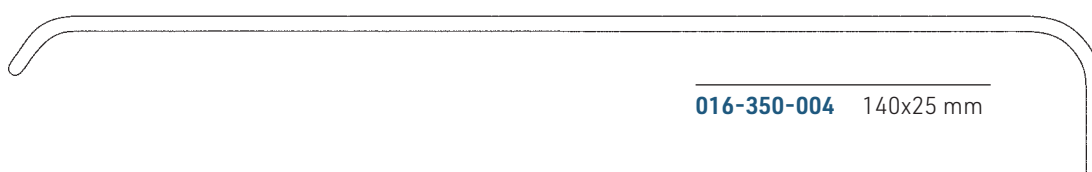
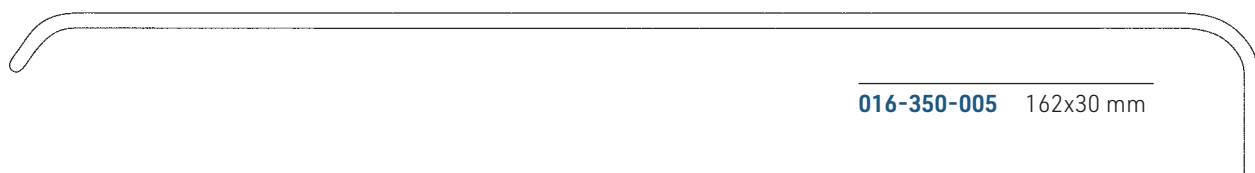
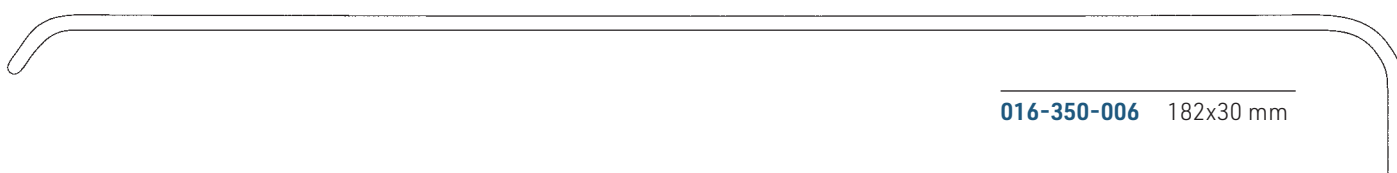

BRUNNER

016-350-001 - 016-350-006 25,0 cm / 9³/₄"



016

Wundhaken
Retractors
Separadores
Divaricatori



016-352-006 180x30 mm

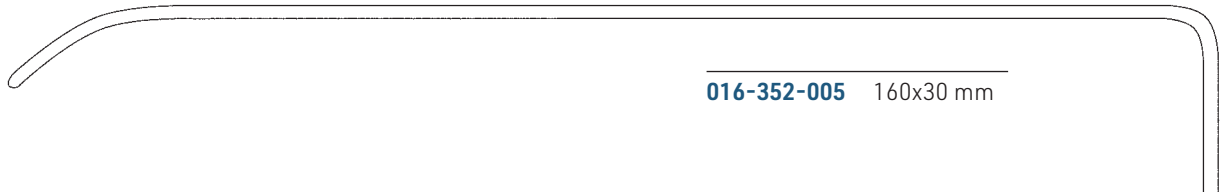

016-352-005 160x30 mm

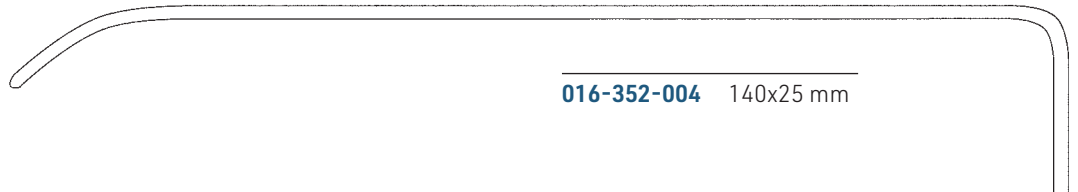

016-352-004 140x25 mm



016-352-003 120x25 mm

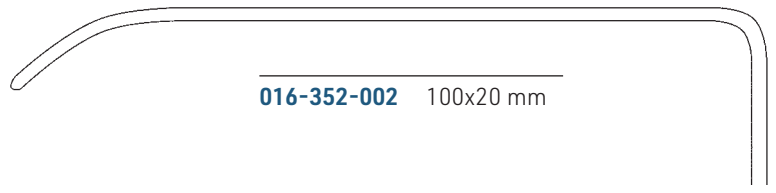

016-352-002 100x20 mm

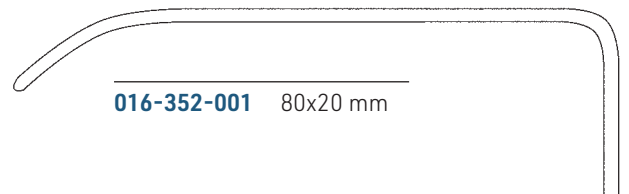

016-352-001 80x20 mm

BRUNNER

016-352-001 - 016-352-006 25,0 cm / 9³/₄"

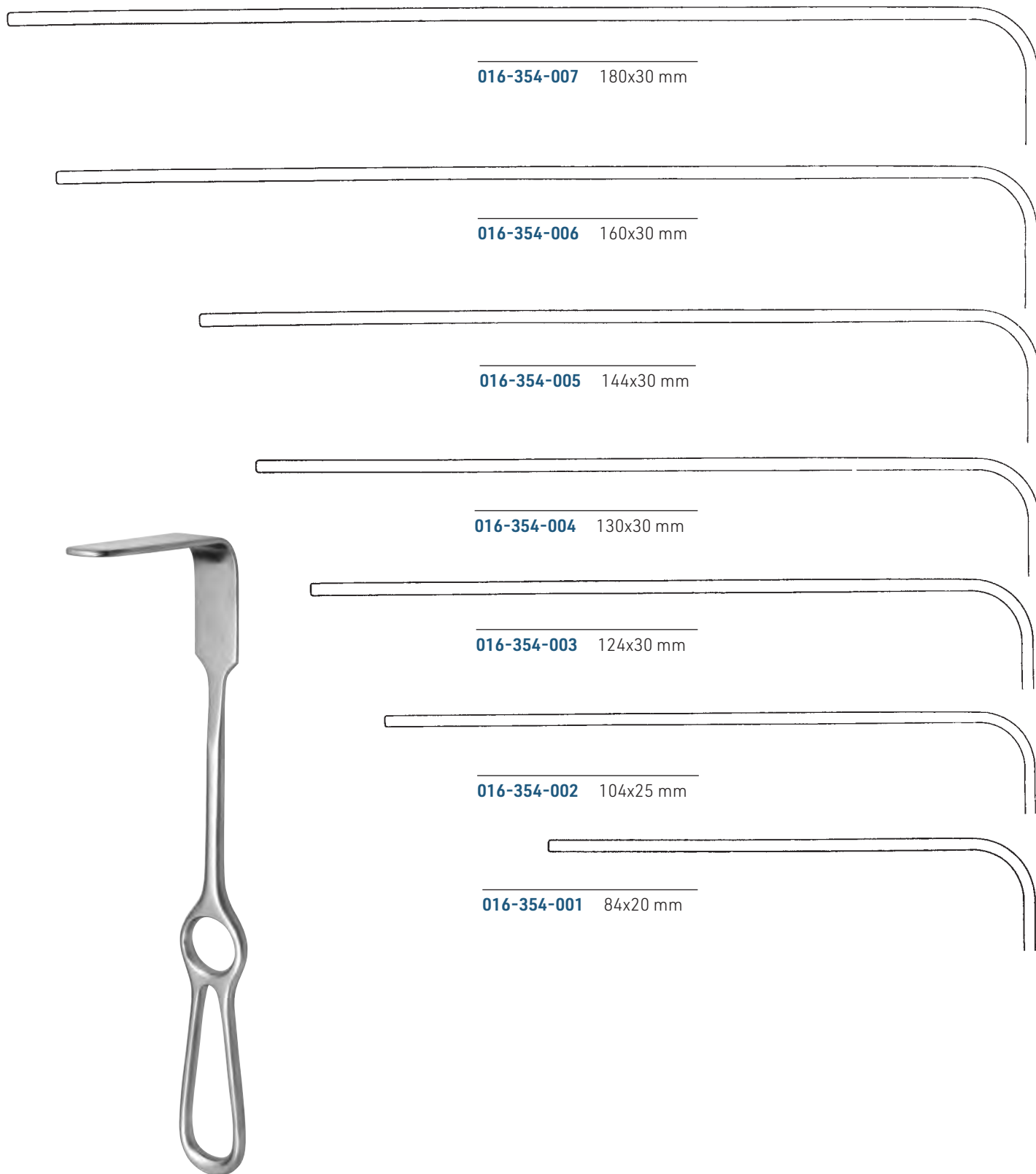

016-354-007 180x30 mm

016-354-006 160x30 mm

016-354-005 144x30 mm

016-354-004 130x30 mm

016-354-003 124x30 mm

016-354-002 104x25 mm

016-354-001 84x20 mm

BRUNNER

016-354-001 - 016-354-007 25,5 cm / 10"



016

Wundhaken
Retractors
Separadores
Divaricatori



016-358-001 15x15 mm

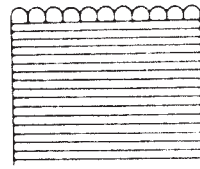

016-358-002 15x23 mm

CRAWFORD

016-358-001 - 016-358-002 19,0 cm / 7¹/₂"



016-360-001 Fig. 1



016-360-002 Fig. 2



016-360-003 Fig. 3



016-360-004 Fig. 4



016-360-005 Fig. 5



016-360-006 Fig. 6

ROSS

016-360-001 - 016-360-006 25,0 cm / 9³/₄"

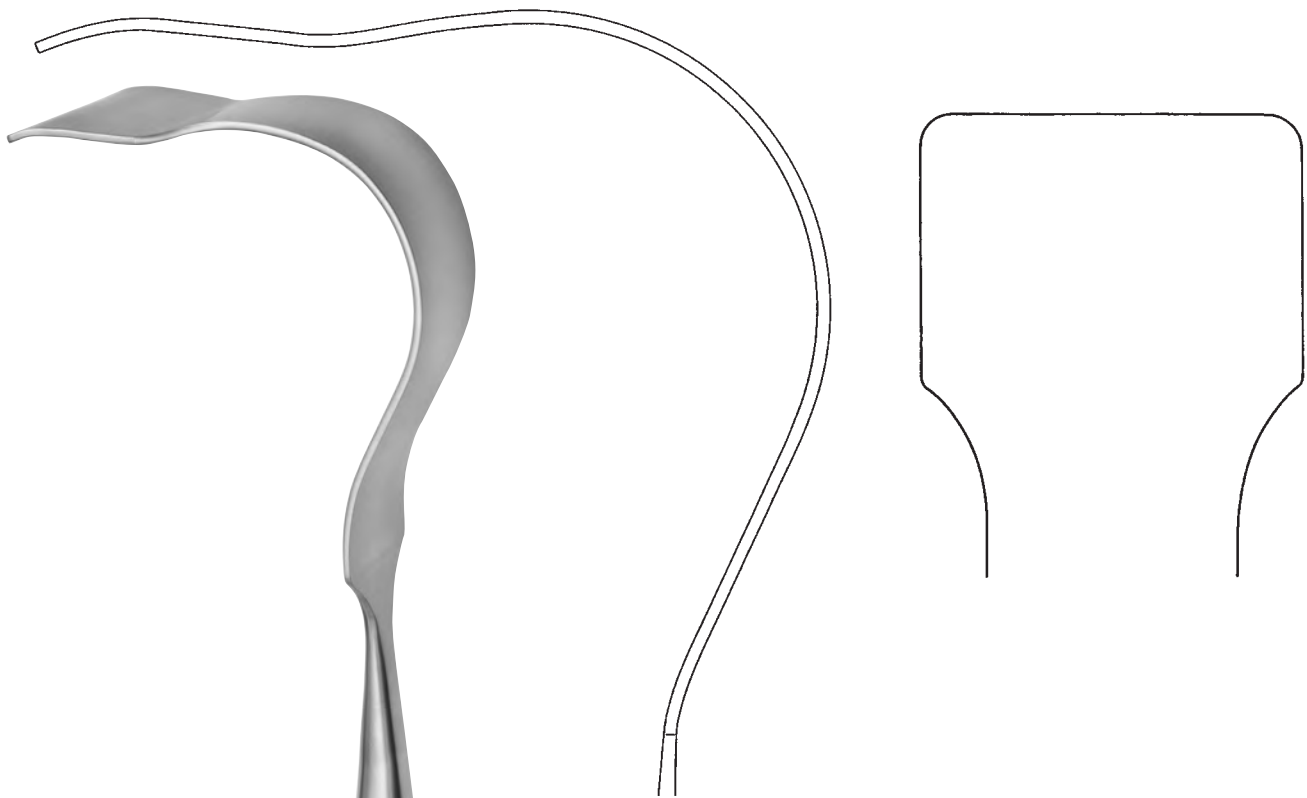

POLLOSON
016-366-001 29,0 cm / 11¹/₂"



POLLOSON
016-366-002 27,0 cm / 10³/₄"



016

Wundhaken
Retractors
Separadores
Divaricatori



HARRINGTON

016-370-001	31,5 cm / 12 1/2"	137x44 mm
016-370-002	31,5 cm / 12 1/2"	137x65 mm



MORRIS

016-380-040	24,5 cm / 9 2/3"	70x40 mm
016-380-050	24,5 cm / 9 2/3"	70x50 mm
016-380-065	24,5 cm / 9 2/3"	70x65 mm



MEYERDING

016-390-001 - 016-390-003 23 cm / 8³/₄"

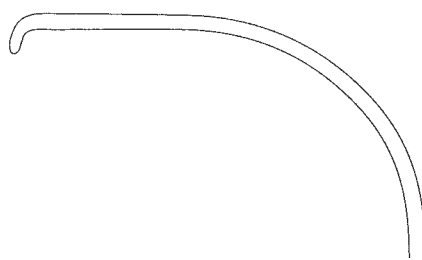

016-390-001 50x16 mm 23,0 cm

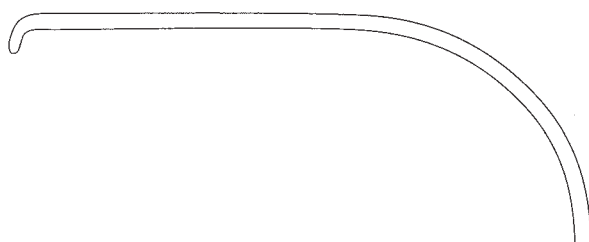

016-390-002 75x25 mm 23,0 cm

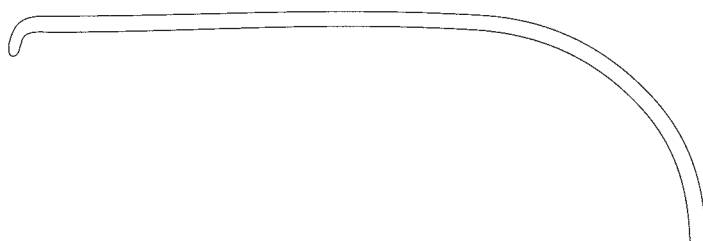

016-390-003 90x50 mm 25,5 cm



19 mm

DEAVER

016-400-001 18,0 cm / 7"



22 mm

DEAVER

016-400-002 21,5 cm / 8¹/₂"

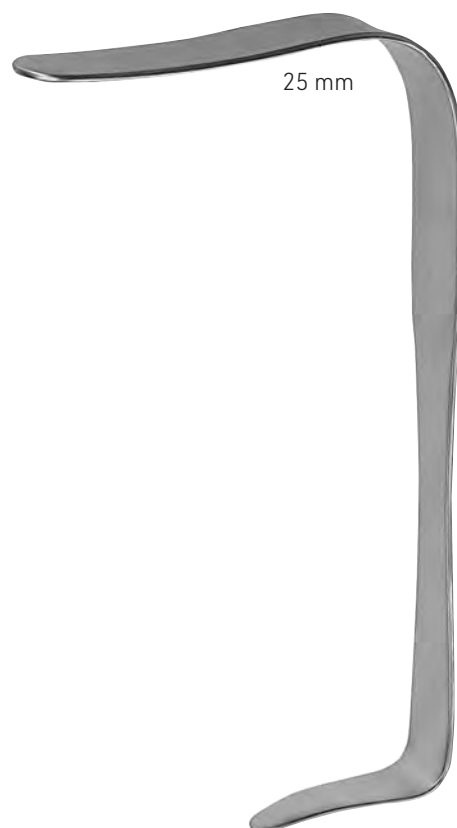

25 mm

DEAVER

016-400-003 25,0 cm / 9³/₄"



016

Wundhaken
Retractors
Separadores
Divaricatori



25 mm

DEEVER

016-400-004 31,0 cm / 12¹/₄"



25 mm

DEEVER

016-400-005 33,0 cm / 13"



25 mm

DEEVER

016-400-006 36,0 cm / 14¹/₈"



38 mm

DEEVER

016-400-007 30,0 cm / 11³/₄"



50 mm

DEEVER

016-400-008 31,0 cm / 12¹/₄"



75 mm

DEEVER

016-400-009 31,5 cm / 12¹/₂"



DEAVER

016-402-025	31,5 cm / 12 ¹ / ₂ "	25 mm
016-402-038	31,5 cm / 12 ¹ / ₂ "	38 mm
016-402-050	31,5 cm / 12 ¹ / ₂ "	50 mm
016-402-075	31,0 cm / 12 ¹ / ₄ "	75 mm



48 x 48 mm
rechts
right
derecho
destra

COOLEY

016-410-001 25,0 cm / 9³/₄"



48 x 48 mm
rechts gerieft
right serrated
derecho, estriado
destra, con striatura

COOLEY

016-410-002 25,0 cm / 9³/₄"



30 x 48 mm
links
left
izquierdo
sinistra

COOLEY

016-410-003 27,0 cm / 10³/₄"



016

Wundhaken
Retractors
Separadores
Divaricatori

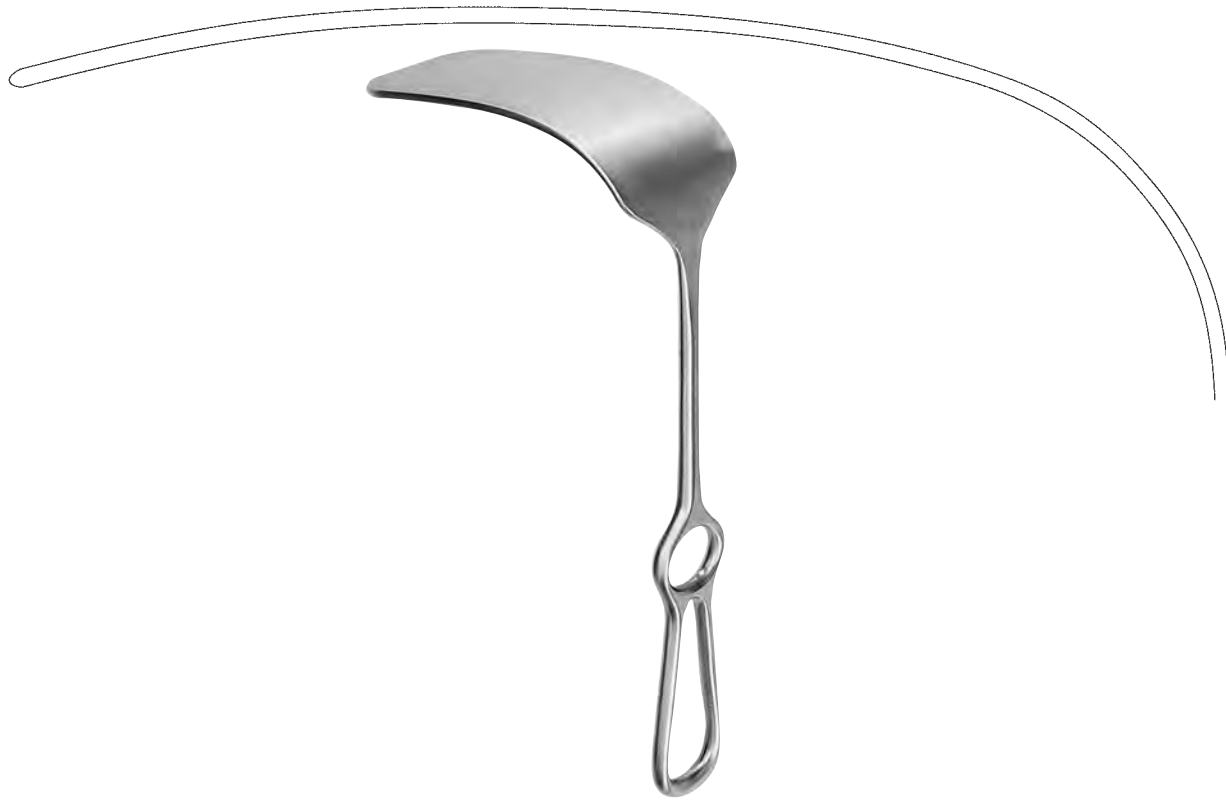

MIKULICZ

016-414-001	25,0 cm / 9 ³ / ₄ "	90x35 mm
016-414-002	25,0 cm / 9 ³ / ₄ "	125 x50 mm
016-414-003	25,0 cm / 9 ³ / ₄ "	160 x50 mm

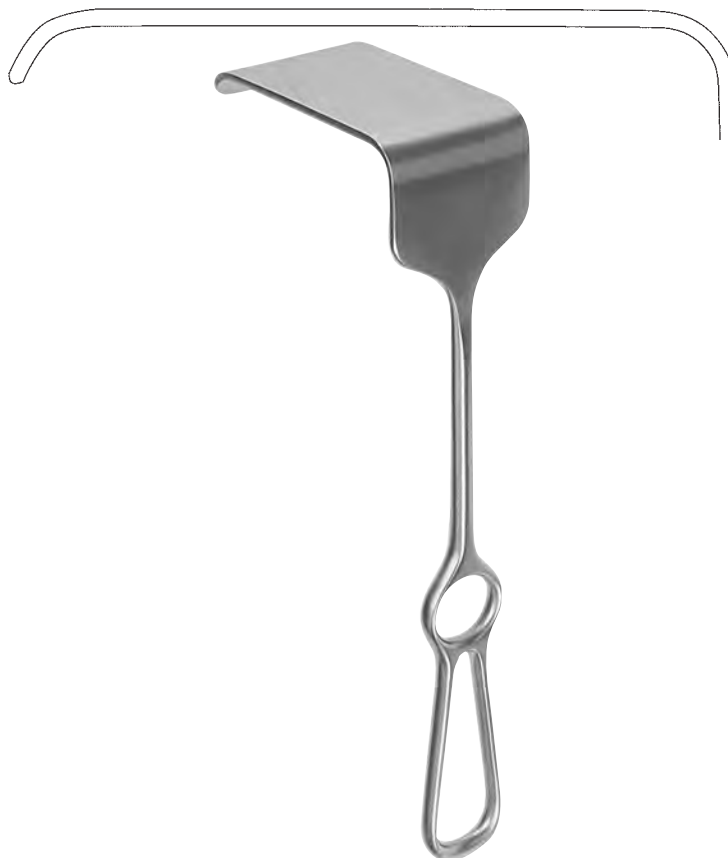

MIKULICZ

016-416-260	26,0 cm / 10 ¹ / ₄ "	90 x 55 mm
--------------------	--	------------



KELLY

016-420-001	27,0 cm / 10 ³ / ₄ "	160x38 mm
016-420-002	27,0 cm / 10 ³ / ₄ "	160x57 mm
016-420-003	27,0 cm / 10 ³ / ₄ "	190x38 mm
016-420-004	27,0 cm / 10 ³ / ₄ "	190x57 mm



ST. MARKS

016-422-001 - 016-422-003

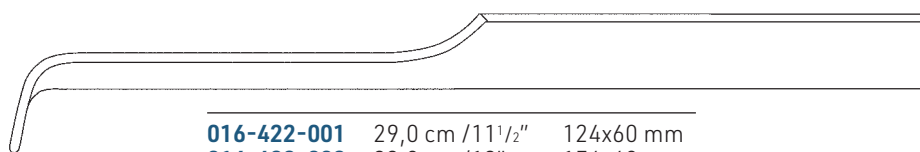

016-422-001	29,0 cm / 11 ¹ / ₂ "	124x60 mm
016-422-002	33,0 cm / 13"	174x60 mm

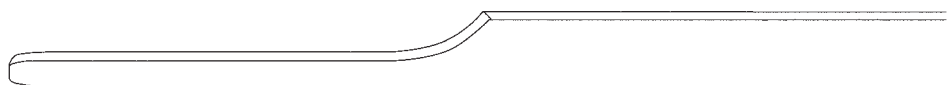

016-422-003	33,0 cm / 13"	178x60 mm
--------------------	---------------	-----------



016

Wundhaken
Retractors
Separadores
Divaricatori

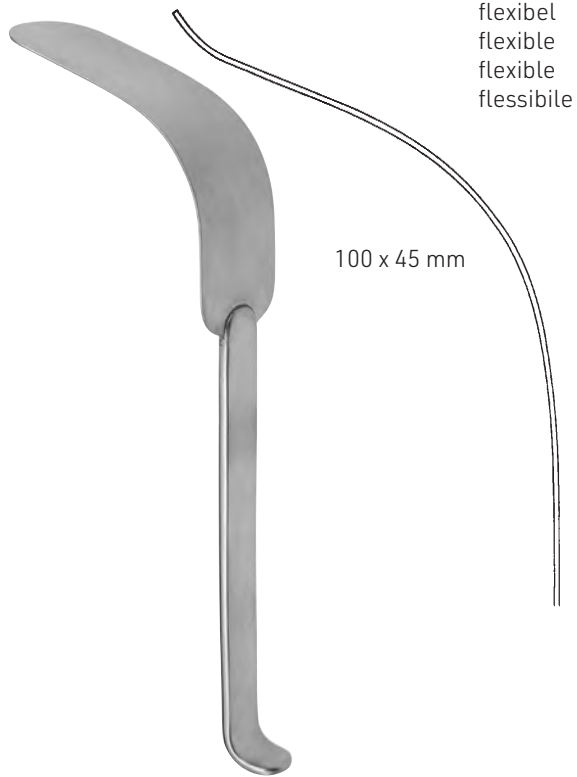

flexibel
flexible
flexible
flessibile

100 x 45 mm

KUEMMEL

016-426-280 28,0 cm / 11"

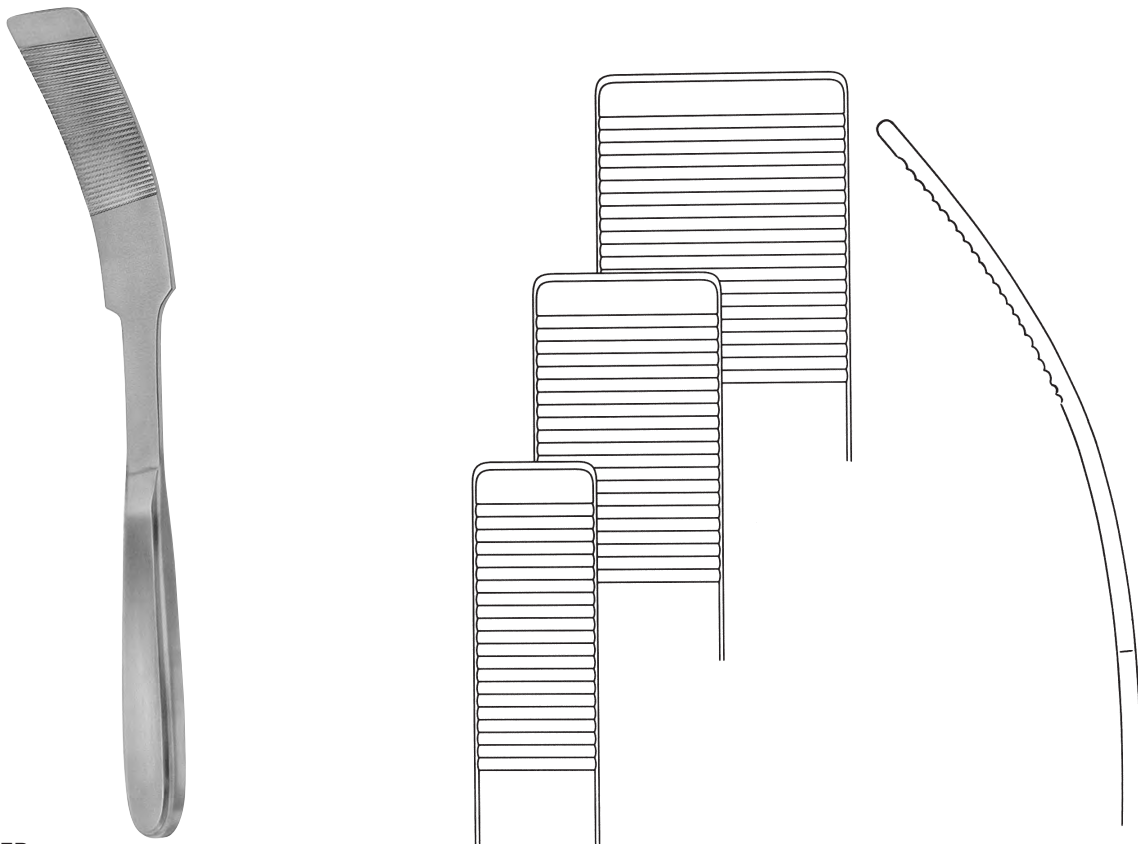

KADER

016-430-020	28,0 cm / 11"	20 mm
016-430-030	28,0 cm / 11"	30 mm
016-430-040	28,0 cm / 11"	40 mm



Fig.1 24x20 mm
Fig.2 29x26 mm
Fig.3 33x29 mm

Satz, Fig. 1-3
Set, fig. 1-3
Juego, fig. 1-3
Serie, fig. 1-3

Fig.1 30x28 mm
Fig.2 36x36 mm
Fig.3 38x43 mm

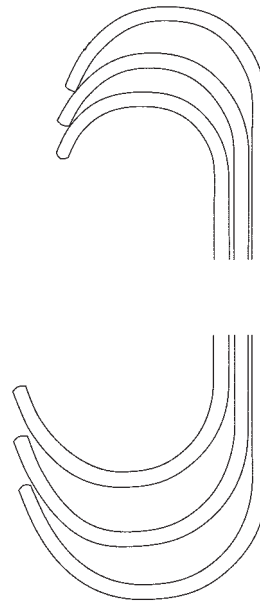

ROUX

016-450-000	17,0 cm / 6 ³ / ₄ "	Fig.1-3
016-450-001	14,0 cm / 5 ¹ / ₂ "	Fig.1
016-450-002	15,0 cm / 6"	Fig.2
016-450-003	17,0 cm / 6 ³ / ₄ "	Fig.3



Fig.2 30x10 mm
Fig.1 26x10 mm

Fig.1 30x13 mm
Fig.2 34x13 mm

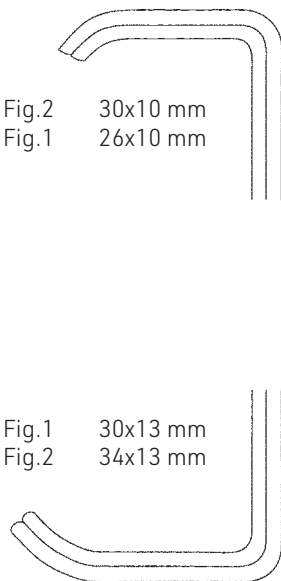

FARABEUF

016-454-000	11,5 cm / 4 ¹ / ₄ "	Fig.1-2
016-454-001	11,5 cm / 4 ¹ / ₄ "	Fig.1
016-454-002	11,5 cm / 4 ¹ / ₄ "	Fig.2



Fig.1 23x16 mm
Fig.2 27x16 mm

Fig.1 26x16 mm
Fig.2 30x16 mm



FARABEUF

016-456-000	15,0 cm / 6"	Fig.1-2
016-456-001	15,0 cm / 6"	Fig.1
016-456-002	15,0 cm / 6"	Fig.2



016

Wundhaken
Retractors
Separadores
Divaricatori



MINI-ROUX

016-458-140 14,0 cm / 5 1/2"

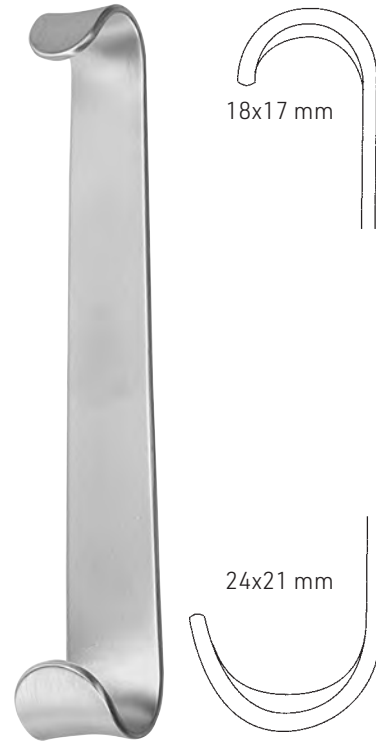

BABY-ROUX

016-460-130 13,0 cm / 5"



Fig.2 22x15 mm
Fig.1 19x15 mm

Fig.1 19x15 mm
Fig.2 22x15 mm

PARKER

016-464-000 13,5 cm / 5 1/4" Fig.1-2
016-464-001 13,5 cm / 5 1/4" Fig.1
016-464-002 13,5 cm / 5 1/4" Fig.2

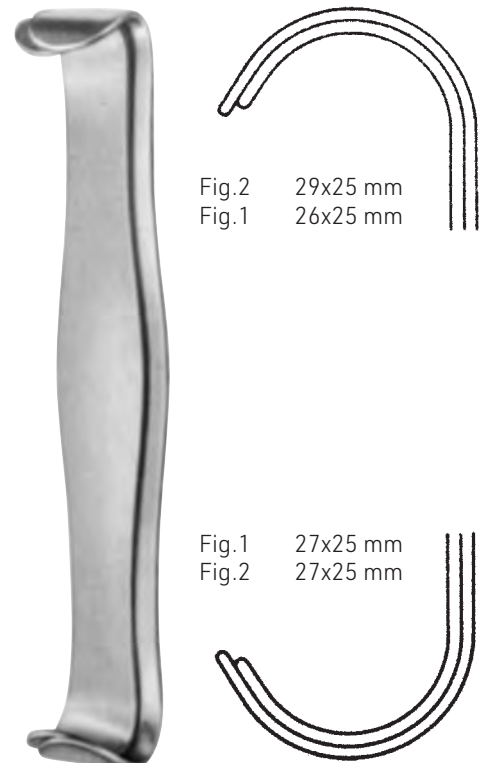

Fig.2 29x25 mm
Fig.1 26x25 mm

Fig.1 27x25 mm
Fig.2 27x25 mm

PARKER

016-466-000 17,5 cm / 7" Fig.1-2
016-466-001 17,5 cm / 7" Fig.1
016-466-002 17,5 cm / 7" Fig.2

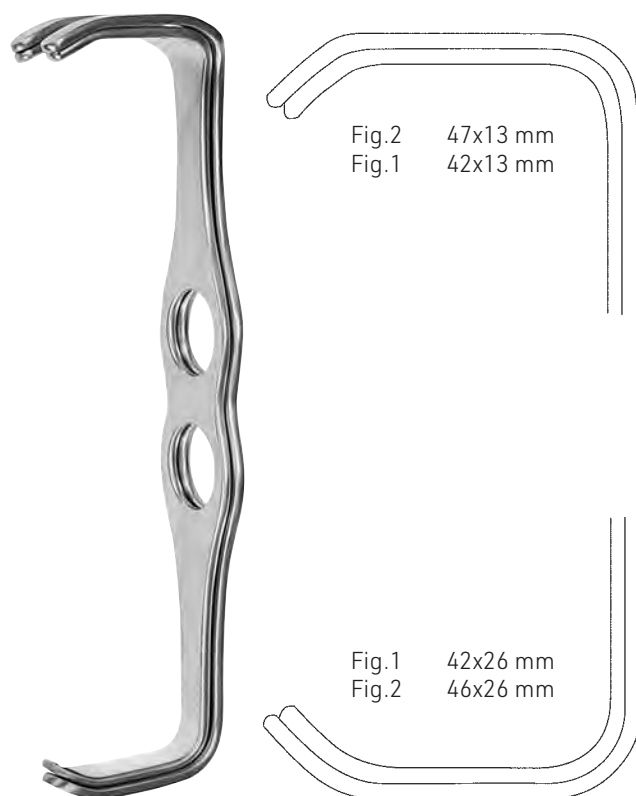

Fig.2 47x13 mm
Fig.1 42x13 mm

Fig.1 42x26 mm
Fig.2 46x26 mm

MATHIEU

016-470-000	20,0 cm / 8"	Fig.1-2
016-470-001	20,0 cm / 8"	Fig.1
016-470-002	20,0 cm / 8"	Fig.2



40x40 mm

30x30 mm

GOLET

016-472-190	19,0 cm / 7½"
--------------------	---------------

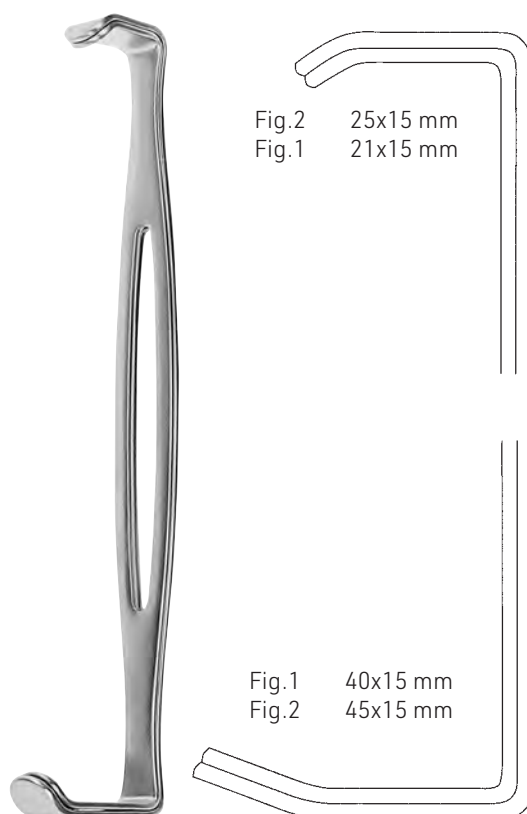

Fig.2 25x15 mm
Fig.1 21x15 mm

Fig.1 40x15 mm
Fig.2 45x15 mm

PARKER-LANGENBECK

016-474-000	21,5 cm / 8½"	Fig.1-2
016-474-001	21,5 cm / 8½"	Fig.1
016-474-002	21,5 cm / 8½"	Fig.2



016

Wundhaken
Retractors
Separadores
Divaricatori

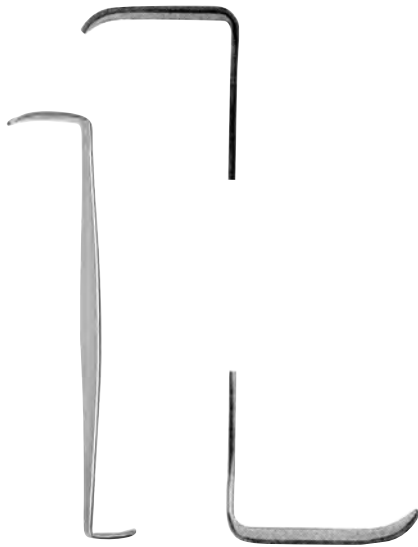

CRILE

016-478-110 11,0 cm / 4¹/₄"



LUER

016-479-110 11,0 cm / 4¹/₄"



COLLIN

016-480-145 14,5 cm / 5³/₄"



REVERDIN

016-485-290 29,0 cm / 11 1/2"



REVERDIN

016-486-280 28,5 cm / 11"



biegsam
 malleable
 maleable
 malleabile

RIBBON

016-490-030 330x30 mm
016-490-040 330x40 mm
016-490-050 330x50 mm



biegsam
 malleable
 maleable
 malleabile

HABERER

016-492-200 200x17/25 mm
016-492-280 280x25/30 mm
016-492-300 300x37/45 mm



biegsam
 malleable
 maleable
 malleabile

RIBBON

016-494-012 200x12 mm
016-494-017 200x17 mm
016-494-025 200x25 mm



016

Wundspreizer
Self-Retaining Retractors
Separadores autoestáticos
Divaricatori autostatici

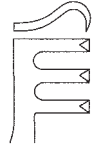

scharf
sharp
agudo
acuto

016-500-005

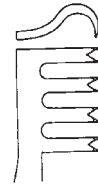

scharf
sharp
agudo
acuto

016-500-007

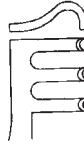

stumpf
blunt
romo
smusso

016-501-005

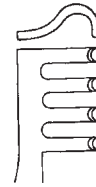

stumpf
blunt
romo
smusso

016-501-007



FINSEN

016-500-005 - 016-501-005
016-500-007 - 016-501-007

5,0 cm / 2"
7,0 cm / 2³/₄"

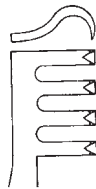

016-504-007

scharf
sharp
agudo
acuto

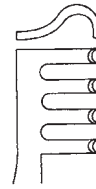

016-505-007

stumpf
blunt
romo
smusso

FINSEN

016-504-007 - 016-505-007

7,0 cm / 2³/₄"

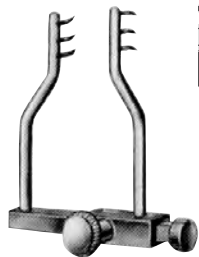

scharf
sharp
agudo
acuto

LOGAN

016-506-004 4,0 cm / 1¹/₂"



scharf
sharp
agudo
acuto

BUCKLEY

016-508-006 6,0 cm / 2¹/₄"



ALM

016-510-007 - 016-511-007 7,0 cm / 2³/₄"
 016-510-010 - 016-511-010 10,0 cm / 4"

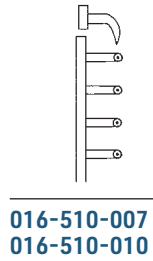

scharf
 sharp
 agudo
 acuto

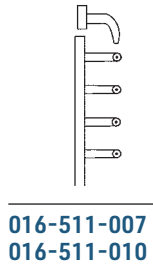

stumpf
 blunt
 romo
 smusso



ALLPORT

016-512-095 9,5 cm / 3³/₄"



HOLZHEIMER

016-514-010 - 016-515-010 10,0 cm / 4"



scharf
 sharp
 agudo
 acuto



stumpf
 blunt
 romo
 smusso



JANSEN

016-520-010 - 016-521-010 10,0 cm / 4"

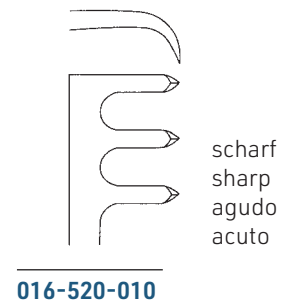

scharf
 sharp
 agudo
 acuto



stumpf
 blunt
 romo
 smusso



016

Wundspreizer
Self-Retaining Retractors
Separadores autoestáticos
Divaricatori autostatici

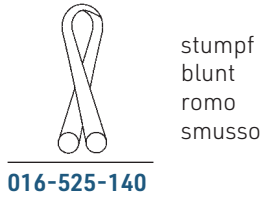

SCALP-CONTOUR

016-524-140 - 016-525-140 14,0 cm / 5 1/2"

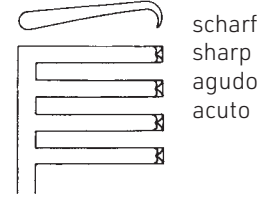

ANDERSON-ADSON

016-530-195 20,0 cm / 8"

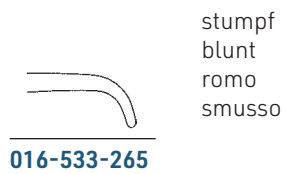
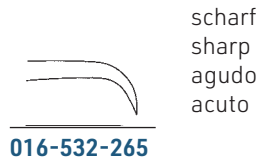

ADSON

016-532-265 - 016-533-265 26,5 cm / 10 1/2"

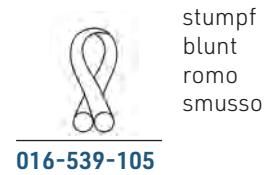
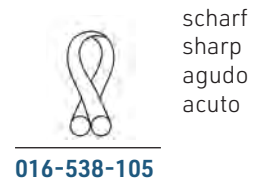

WEITLANER-LOKTITE

016-538-105 - 016-539-105 10,5 cm / 4 1/8"

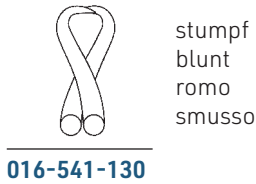
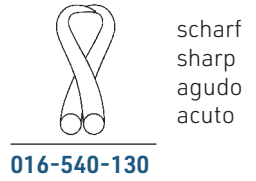

WEITLANER

016-540-130 - 016-541-130 13,0 cm / 5¹/₈"

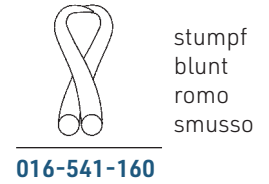
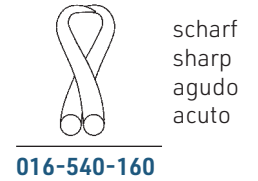

WEITLANER

016-540-160 - 016-541-160 16,0 cm / 6¹/₄"

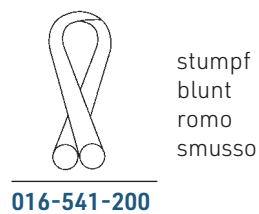

WEITLANER

016-540-200 - 016-541-200 20,0 cm / 8"



WEITLANER

016-540-240 - 016-541-240 24,0 cm / 9¹/₂"



016

Wundspreizer
Self-Retaining Retractors
Separadores autoestáticos
Divaricatori autostatici



scharf
sharp
agudo
acuto

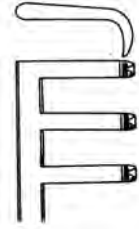

016-544-130

stumpf
blunt
romo
smusso

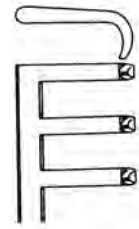

016-545-130

WEITLANER-WULLSTEIN

016-544-130 - 016-545-130 13,0 cm / 5"



scharf
sharp
agudo
acuto

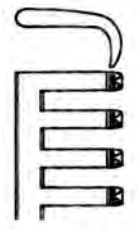

MOLLISON

016-550-155 15,5 cm / 6"



scharf
sharp
agudo
acuto

016-554-130



stumpf
blunt
romo
smusso

016-555-130

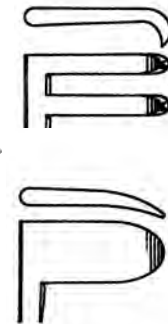

PLESTER

016-554-130 - 016-555-130 13,0 cm / 5"

PLESTER

016-556-110 11,0 cm / 4³/₈"

PLESTER

016-557-110 11,0 cm / 4³/₈"

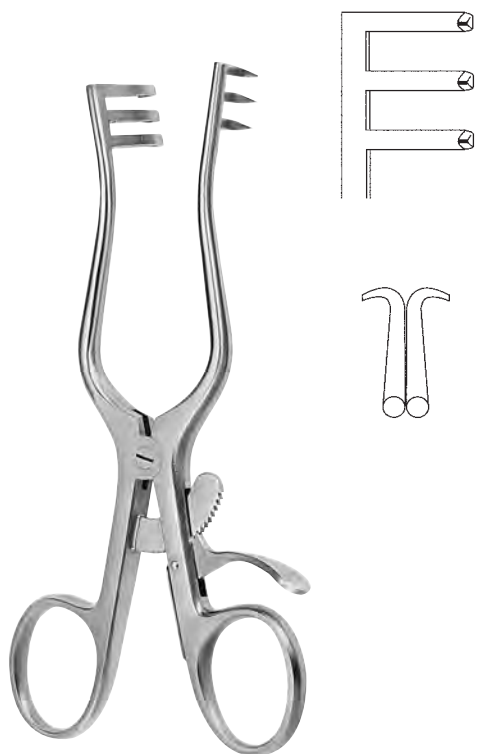

stumpf
 blunt
 romo
 smusso

MILLIGAN

016-560-130 13,0 cm / 5"

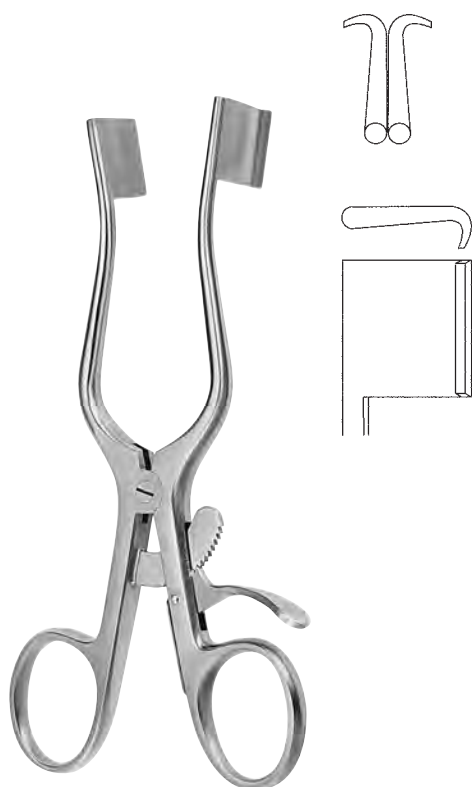

WEITLANER-BABY

016-562-130 13,0 cm / 5"



scharf
 sharp
 agudo
 acuto

016-564-125

stumpf
 blunt
 romo
 smusso

016-565-125

SCHUKNECHT

016-564-125 - 016-565-125 12,5 cm / 5"



016

Wundspreizer
Self-Retaining Retractors
Separadores autoestáticos
Divaricatori autostatici

scharf
sharp
agudo
acuto

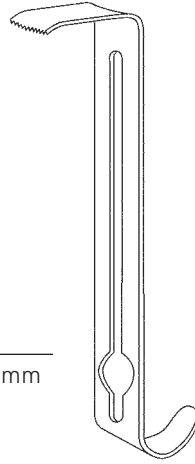
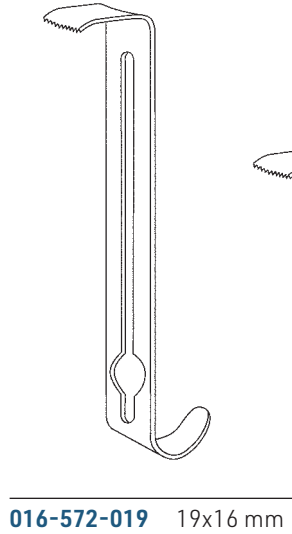

016-572-025 25x16 mm

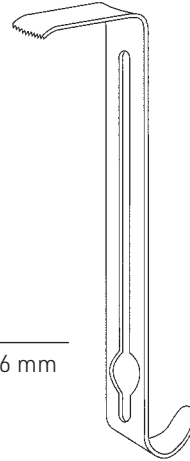

016-572-032 32x16 mm

stumpf
blunt
romo
smusso



HENLEY

016-570-000 16,0 cm / 6 1/4"

HENLEY

016-571-000 16,0 cm / 6 1/4"

HENLEY

016-570-000

komplett, bestehend aus:

- 1 Sperrer mit Seitenvalven, scharf (016-570-001)
- 1 Mittelvalve 19 x 16 mm (016-572-019)
- 1 Mittelvalve 25 x 16 mm (016-572-025)
- 1 Mittelvalve 32 x 16 mm (016-572-032)

complete, consisting of:

- 1 Spreader with lateral valves, sharp (016-570-001)
- 1 Central valve 19 x 16 mm (016-572-019)
- 1 Central valve 25 x 16 mm (016-572-025)
- 1 Central valve 32 x 16 mm (016-572-032)

completo, compuesto de:

- 1 Separador con valvas laterales, agudas (016-570-001)
- 1 Valva central 19 x 16 mm (016-572-019)
- 1 Valva central 25 x 16 mm (016-572-025)
- 1 Valva central 32 x 16 mm (016-572-032)

completo, composto da:

- 1 Divaricatore con valve laterali, acuto (016-570-001)
- 1 Valva centrale 19 x 16 mm (016-572-019)
- 1 Valva centrale 25 x 16 mm (016-572-025)
- 1 Valva centrale 32 x 16 mm (016-572-032)

HENLEY

016-571-000

komplett bestehend aus:

- 1 Sperrer mit Seitenvalven, stumpf (016-571-001)
- 1 Mittelvalve 19 x 16 mm (016-572-019)
- 1 Mittelvalve 25 x 16 mm (016-572-025)
- 1 Mittelvalve 32 x 16 mm (016-572-032)

complete consisting of:

- 1 Spreader with lateral valves, blunt (016-571-001)
- 1 Central valve 19 x 16 mm (016-572-019)
- 1 Central valve 25 x 16 mm (016-572-025)
- 1 Central valve 32 x 16 mm (016-572-032)

completo, compuesto de:

- 1 Separador con valvas laterales, romas (016-571-001)
- 1 Valva central 19 x 16 mm (016-572-019)
- 1 Valva central 25 x 16 mm (016-572-025)
- 1 Valva central 32 x 16 mm (016-572-032)

completo, composto da:

- 1 Divaricatore con valve laterali, smusso (016-571-001)
- 1 Valva centrale 19 x 16 mm (016-572-019)
- 1 Valva centrale 25 x 16 mm (016-572-025)
- 1 Valva centrale 32 x 16 mm (016-572-032)



scharf
sharp
agudo
acuto

ADSON

016-580-130 13,5 cm / 5¹/₄"
016-580-160 16,5 cm / 6¹/₂"



stumpf
blunt
romo
smusso

ADSON

016-581-130 13,5 cm / 5¹/₄"
016-581-160 16,5 cm / 6¹/₂"



016

Wundspreizer
Self-Retaining Retractors
Separadores autoestáticos
Divaricatori autostatici

scharf
sharp
agudo
acuto

stumpf
blunt
romo
smusso

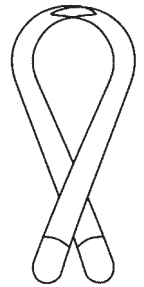
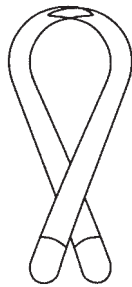

ADSON

016-580-200 20,0 cm / 8"
016-580-260 26,0 cm / 10¹/₄"

ADSON

016-581-200 20,0 cm / 8"
016-581-260 26,0 cm / 10¹/₄"

scharf
sharp
agudo
acuto

stumpf
blunt
romo
smusso

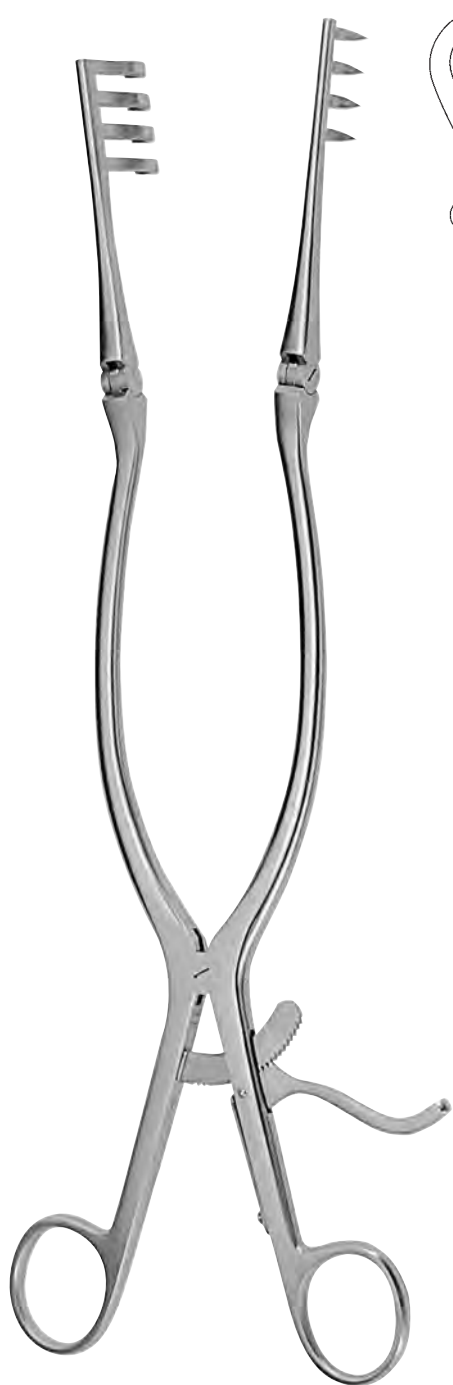

BECKMANN

016-590-320 32,0 cm / 12¹/₂"

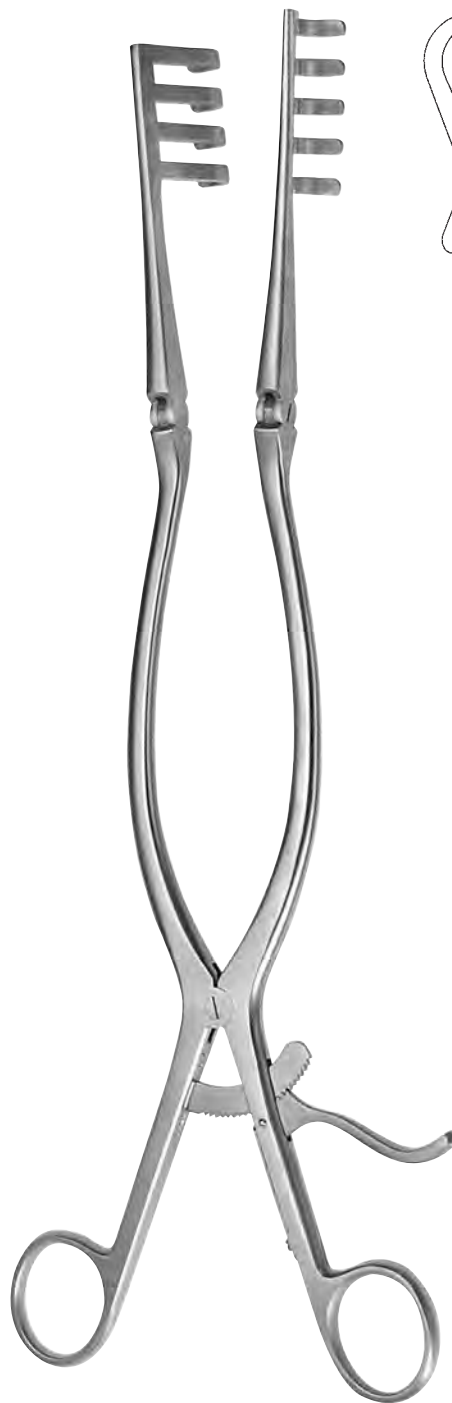

ADSON

016-592-330 33,0 cm / 13"



016

Wundspreizer
Self-Retaining Retractors
Separadores autoestáticos
Divaricatori autostatici

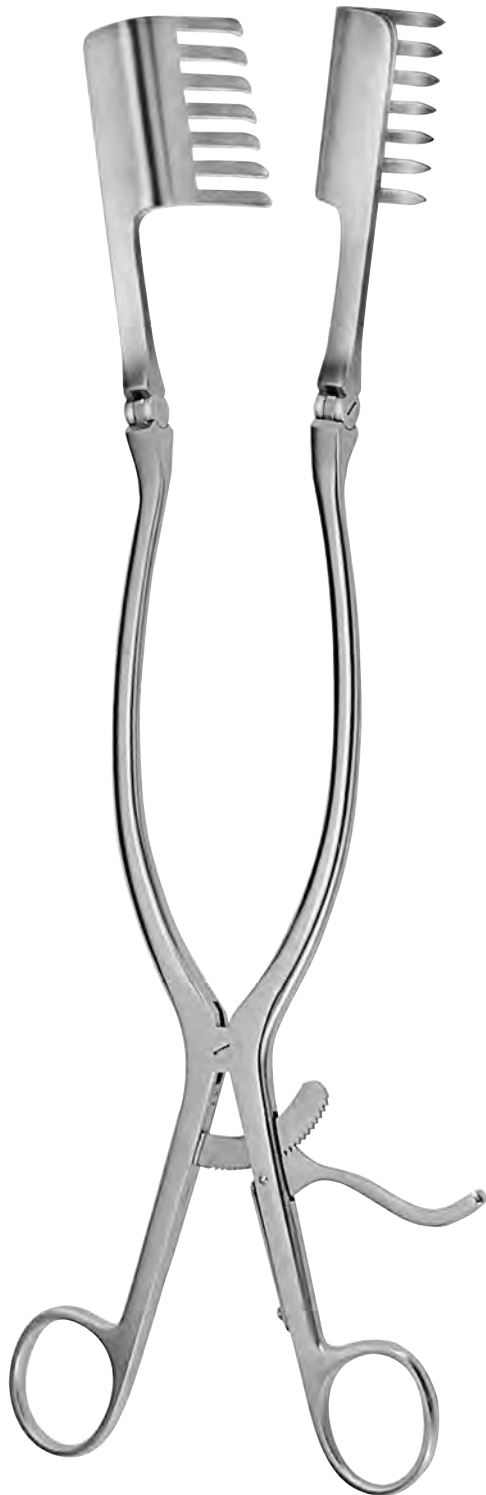

BECKMANN-EATON

016-594-320 32,0 cm / 12¹/₂"



BECKMANN-ADSON

016-596-001 - 016-598-002 30,5 cm / 12¹/₄"



scharf
sharp
agudo
acuto

016-596-001 25x25 mm
016-598-001 25x45 mm



stumpf
blunt
romo
smusso

016-596-002 25x25 mm
016-598-002 25x45 mm



NORFOLK AND NORWICH

016-600-220 22,0 cm / 8³/₄"



RICHTER

016-620-170 17,0 cm / 6³/₄"





016

Wundspreizer
Self-Retaining Retractors
Separadores autoestáticos
Divaricatori autostatici



MAYO-ADAMS

016-622-165 16,5 cm / 6 1/2"



RIGBY

016-626-180 18,0 cm / 7"



JOLL (FRIEDMAN)

016-630-155 15,5 cm / 6"



GELPI

016-640-090 9,0 cm / 3 1/2"
016-640-110 11,0 cm / 4 3/8"



GELPI

016-640-130 13,0 cm / 5 3/8"



GELPI

016-640-160 16,0 cm / 6 1/4"
016-640-180 18,0 cm / 7"



GELPI-LOKTITE

016-641-180 18,0 cm / 7"



016

Wundspreizer für die cervicale Wirbelsäule
Retractors for cervical spine
Separadores para la columna cervical
Divaricatori per colonna cervicale



016-650-040 40x15-23 mm (axb)



016-650-045 45x15-23 mm (axb)



016-650-050 50x15-23 mm (axb)



016-650-055 55x15-23 mm (axb)



016-650-060 60x15-23 mm (axb)

CLOWARD

016-650-000

Wundspreizer, komplett, bestehend aus:

- 1 Sperrer (016-650-001)
- 2 gezahnten Seitenvalven 40x15 - 23 mm (016-650-040)
- 2 gezahnten Seitenvalven 45x15 - 23 mm (016-650-045)
- 2 gezahnten Seitenvalven 50x15 - 23 mm (016-650-050)
- 2 gezahnten Seitenvalven 55x15 - 23 mm (016-650-055)
- 2 gezahnten Seitenvalven 60x15 - 23 mm (016-650-060)

Self-retaining retractor, complete, consisting of:

- 1 Spreader (016-650-001)
- 2 Lateral valves, serrated, 40x15 - 23 mm (016-650-040)
- 2 Lateral valves, serrated, 45x15 - 23 mm (016-650-045)
- 2 Lateral valves, serrated, 50x15 - 23 mm (016-650-050)
- 2 Lateral valves, serrated, 55x15 - 23 mm (016-650-055)
- 2 Lateral valves, serrated, 60x15 - 23 mm (016-650-060)

Separador, completo, compuesto de:

- 1 Separador (016-650-001)
- 2 Valvas laterales, dentadas, 40x15 - 23 mm (016-650-040)
- 2 Valvas laterales, dentadas, 45x15 - 23 mm (016-650-045)
- 2 Valvas laterales, dentadas, 50x15 - 23 mm (016-650-050)
- 2 Valvas laterales, dentadas, 55x15 - 23 mm (016-650-055)
- 2 Valvas laterales, dentadas, 60x15 - 23 mm (016-650-060)

Divaricatore, completo, composto da:

- 1 Divaricatore (016-650-001)
- 2 Valve laterale, dentellata, 40x15 - 23 mm (016-650-040)
- 2 Valve laterale, dentellata, 45x15 - 23 mm (016-650-045)
- 2 Valve laterale, dentellata, 50x15 - 23 mm (016-650-050)
- 2 Valve laterale, dentellata, 55x15 - 23 mm (016-650-055)
- 2 Valve laterale, dentellata, 60x15 - 23 mm (016-650-060)

← 80 mm →



CLOWARD

016-650-001 25,0 cm / 9³/₄"

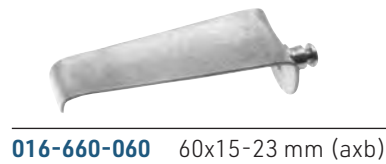
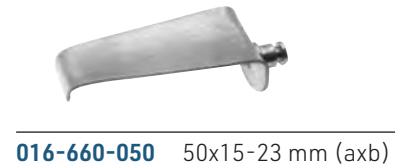
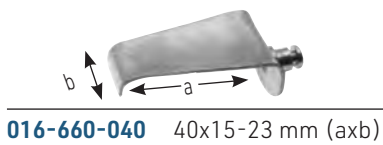

CLOWARD

016-660-000

Wundspreizer, komplett, bestehend aus:

- 1 Sperrer (016-660-001)
- 2 stumpfen Seitenvalven 40x15 - 23 mm (016-660-040)
- 2 stumpfen Seitenvalven 45x15 - 23 mm (016-660-045)
- 2 stumpfen Seitenvalven 50x15 - 23 mm (016-660-050)
- 2 stumpfen Seitenvalven 55x15 - 23 mm (016-660-055)
- 2 stumpfen Seitenvalven 60x15 - 23 mm (016-660-060)

Self-retaining retractor, complete, consisting of:

- 1 Spreader (016-660-001)
- 2 Lateral valves, blunt, 40x15 - 23 mm (016-660-040)
- 2 Lateral valves, blunt, 45x15 - 23 mm (016-660-045)
- 2 Lateral valves, blunt, 50x15 - 23 mm (016-660-050)
- 2 Lateral valves, blunt, 55x15 - 23 mm (016-660-055)
- 2 Lateral valves, blunt, 60x15 - 23 mm (016-660-060)

Separador, completo, compuesto de:

- 1 Separador (016-660-001)
- 2 Valvas laterales, romas, 40x15 - 23 mm (016-660-040)
- 2 Valvas laterales, romas, 45x15 - 23 mm (016-660-045)
- 2 Valvas laterales, romas, 50x15 - 23 mm (016-660-050)
- 2 Valvas laterales, romas, 55x15 - 23 mm (016-660-055)
- 2 Valvas laterales, romas, 60x15 - 23 mm (016-660-060)

Divaricatore, completo, composto da:

- 1 Divaricatore (016-660-001)
- 2 Valve laterale, smussa, 40x15 - 23 mm (016-660-040)
- 2 Valve laterale, smussa, 45x15 - 23 mm (016-660-045)
- 2 Valve laterale, smussa, 50x15 - 23 mm (016-660-050)
- 2 Valve laterale, smussa, 55x15 - 23 mm (016-660-055)
- 2 Valve laterale, smussa, 60x15 - 23 mm (016-660-060)



CLOWARD

016-660-001 15,0 cm / 6"



016

Wundspreizer, Bauchdeckenhalter
Self-Retaining Retractors, Abdominal Retractors
Separadores autoestáticos, Separadores abdominales
Divaricatori autostatici, Divaricatori addominali



016-670-030 30x44 mm



016-670-023 23x44 mm

Wechselvalven
Exchangeable blades
Valvas intercambiabiles
Valve intercambiabili

BABY-COLLIN

016-670-000 18,0 cm / 7"



COLLIN

016-680-000 22,5 cm / 9"



COLLIN

016-682-000 22,5 cm / 9 1/4"



COLLIN-LOKTITE

016-684-000 31,0 cm / 12 1/4"

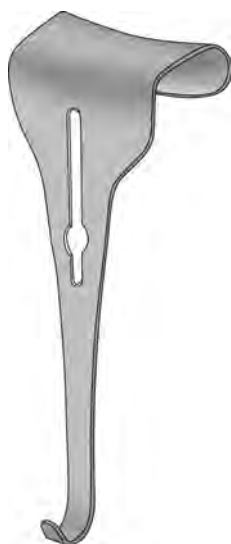

COLLIN

016-686-055 55x55 mm
016-686-065 55x65 mm
016-686-075 55x75 mm

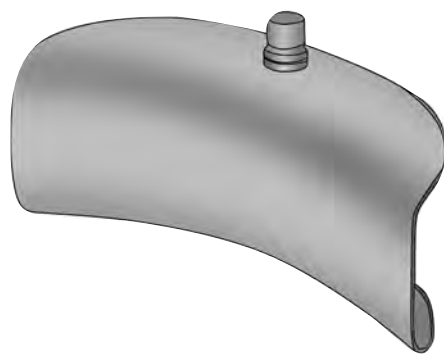

016-688-001 32x 62 mm
016-688-002 38x 80 mm
016-688-003 38x100 mm

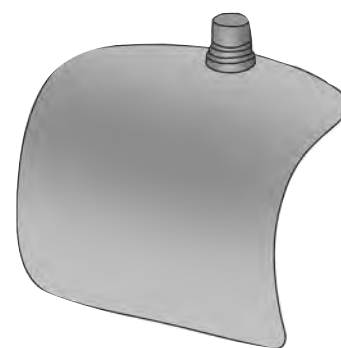

016-688-004 60x80 mm



RICARD

016-711-001 55x70 mm
016-711-002 90x80 mm



016-713-050 50x58 mm
016-713-060 60x80 mm
016-713-072 72x85 mm

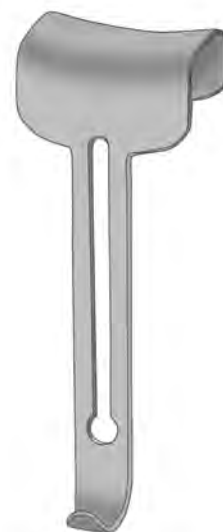

ROBIN-MASSE

016-721-001 40x64 mm



016

Wundspreizer, Bauchdeckenhalter
Self-Retaining Retractors, Abdominal Retractors
Separadores autoestáticos, Separadores abdominales
Divaricatori autostatici, Divaricatori addominali

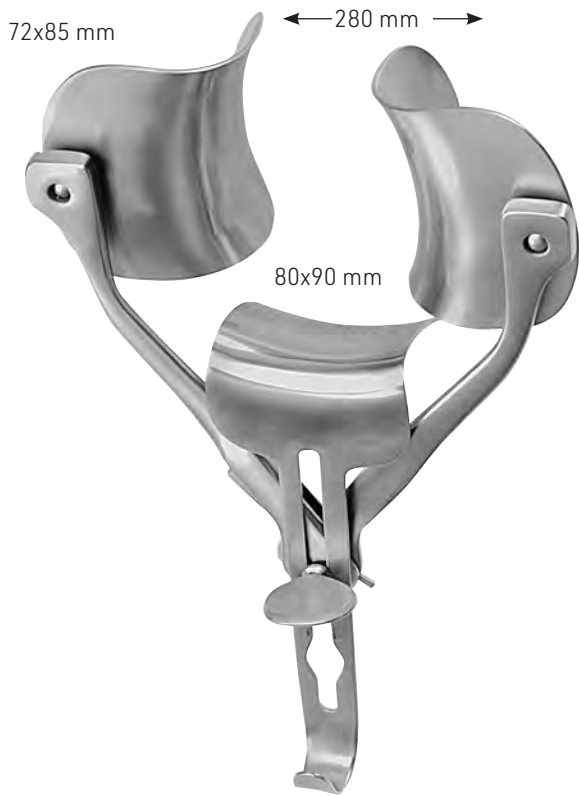

RICARD

016-700-280 28,0 cm / 11"

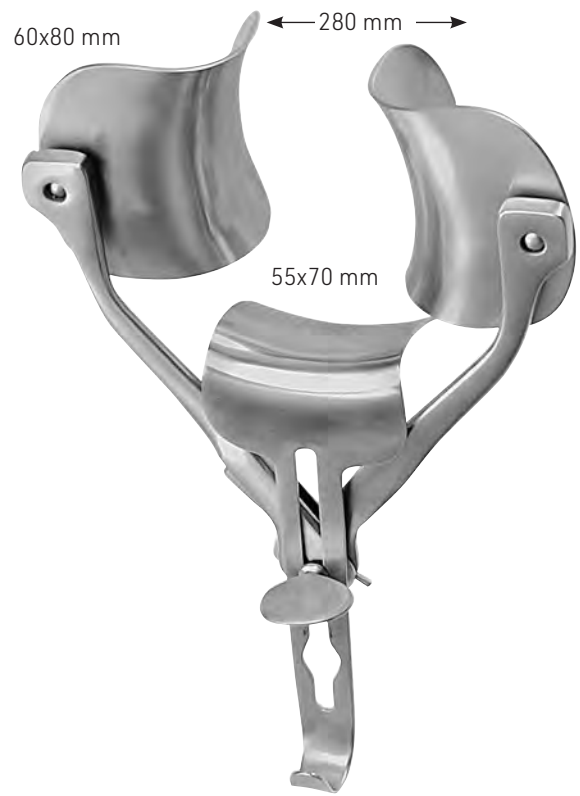

RICARD

016-710-300 30,0 cm / 12"

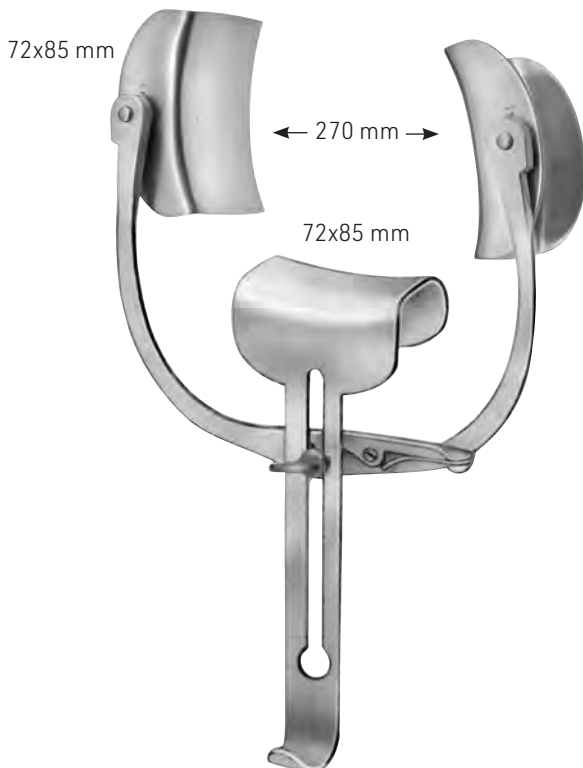

ROBIN-MASSE

016-720-270

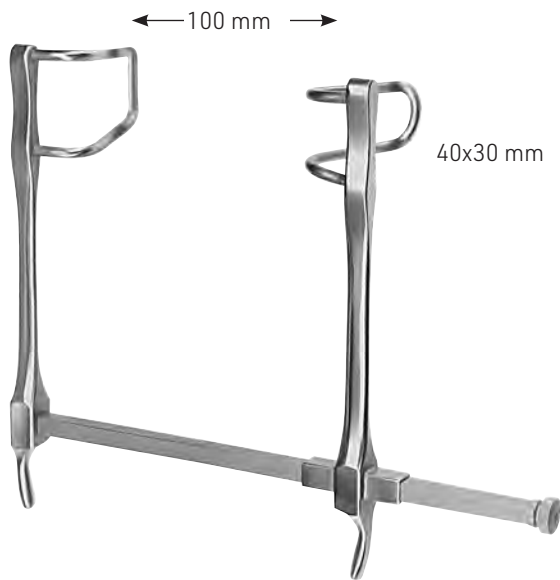

GOSSET
016-730-100

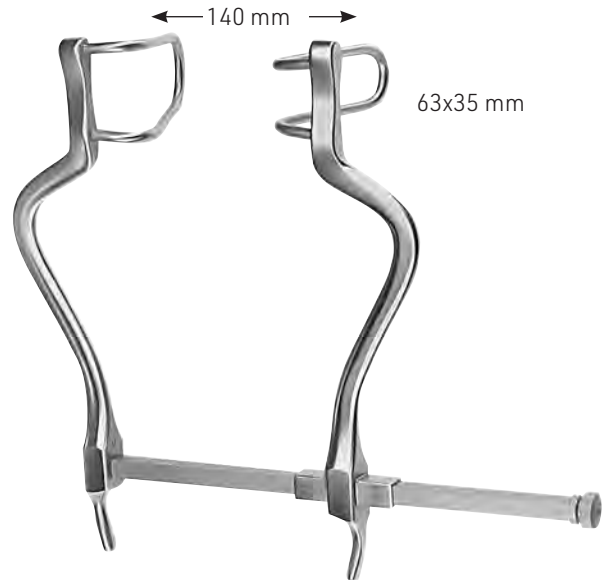

GOSSET
016-730-140

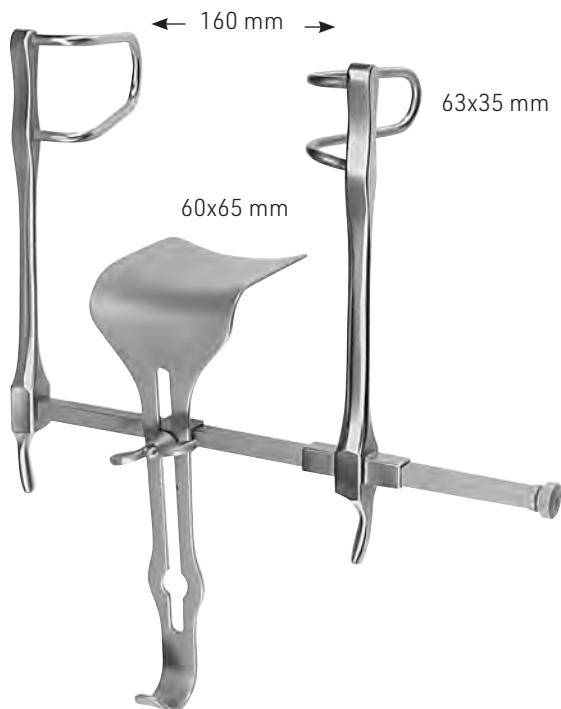

GOSSET
016-730-160

016-731-060 60x65 mm
 Mittelvalve
 Central blade
 Valva central
 Valva centrale

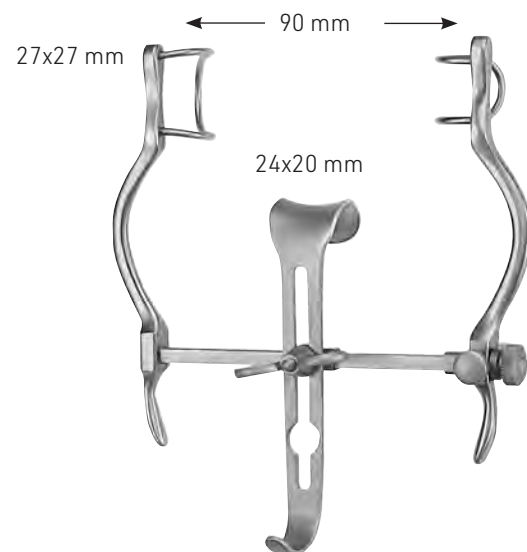

BABY-BALFOUR
016-740-090



016

Bauchdeckenhalter
Abdominal Retractors
Separadores abdominales
Divaricatori addominali

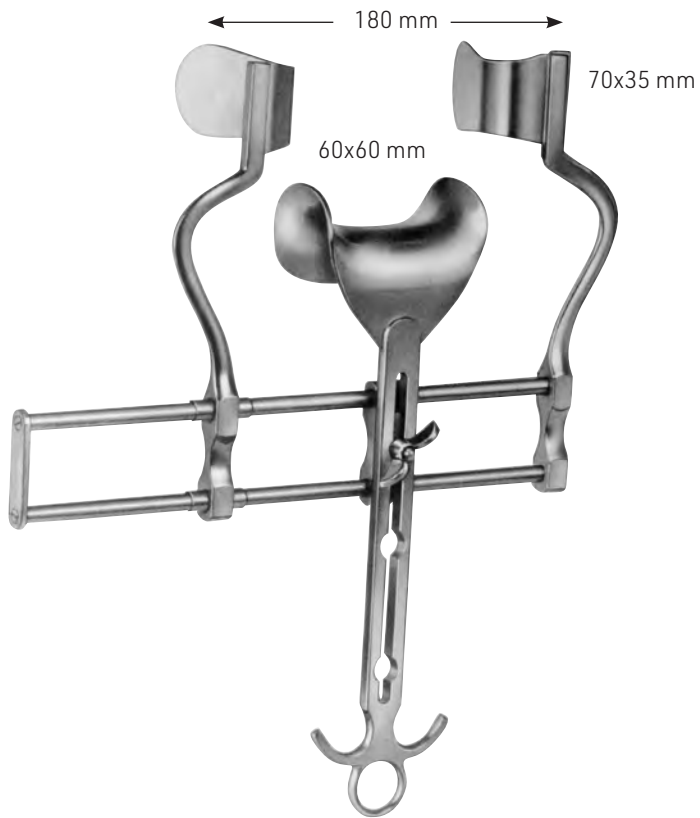

BALFOUR
016-746-180

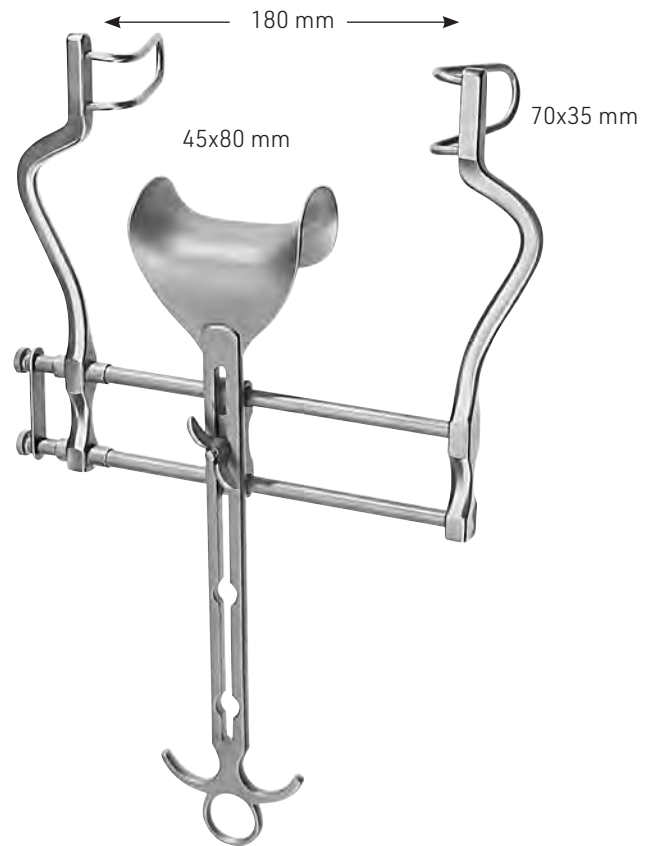

BALFOUR
016-750-180

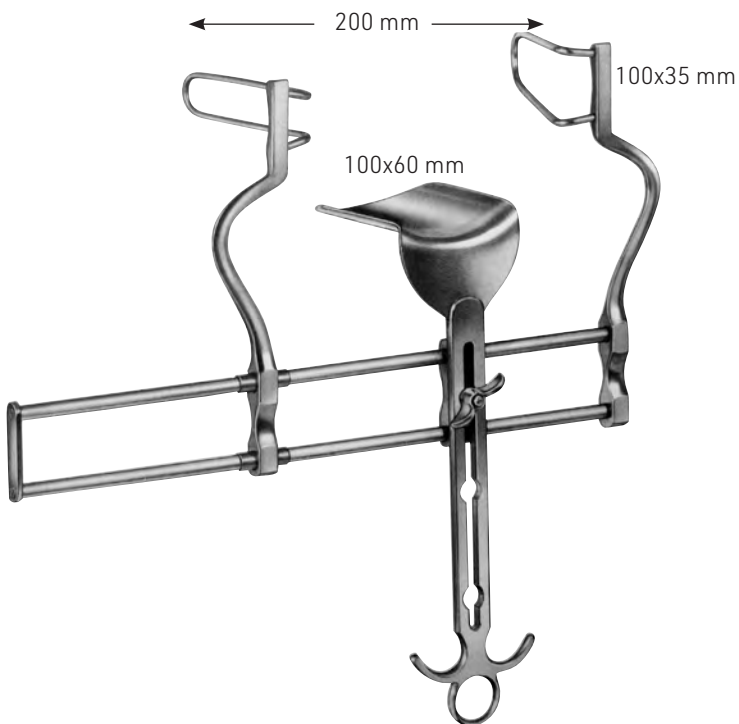

BALFOUR
016-750-200

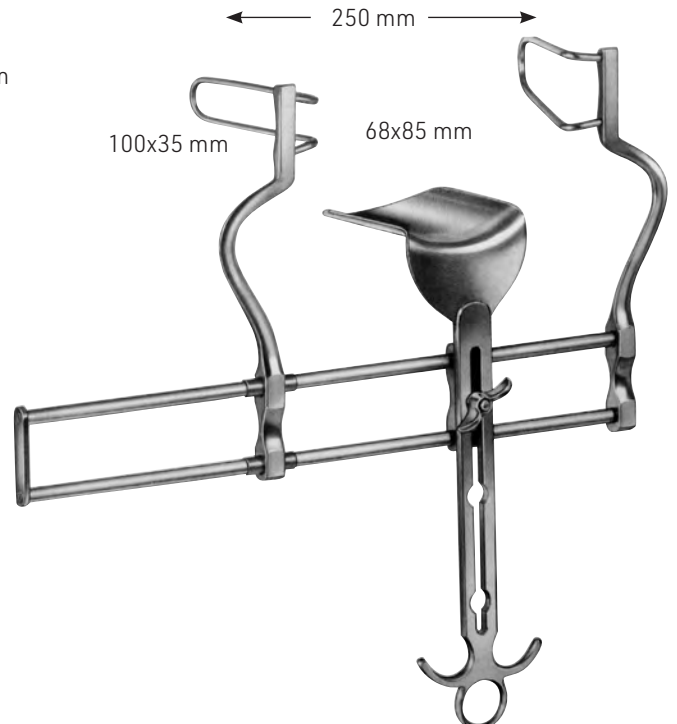

BALFOUR
016-750-250

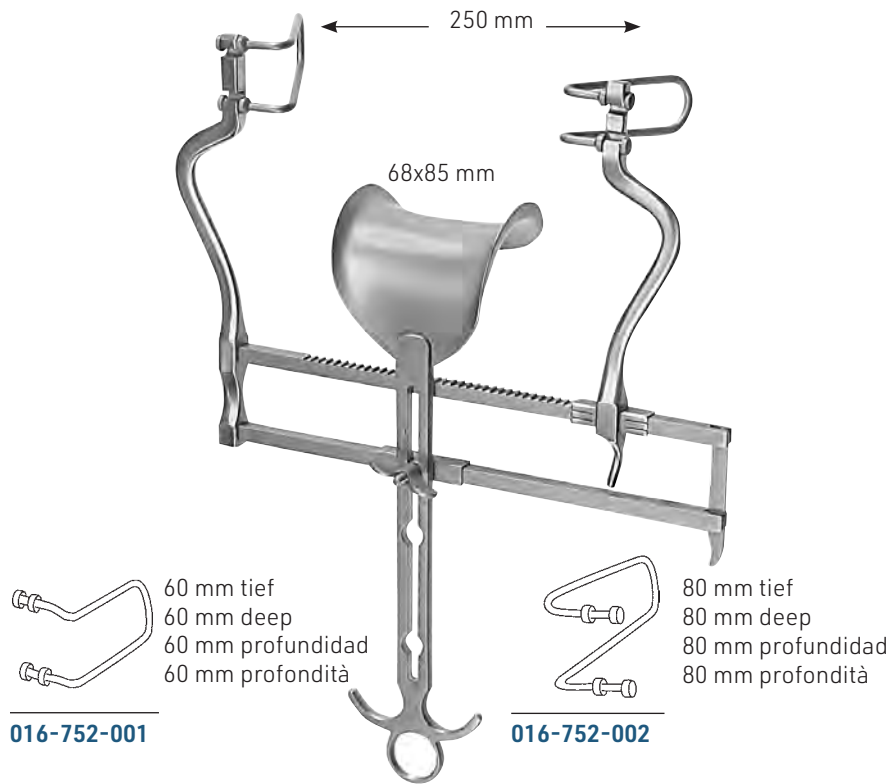

BALFOUR US-TYPE

016-752-000

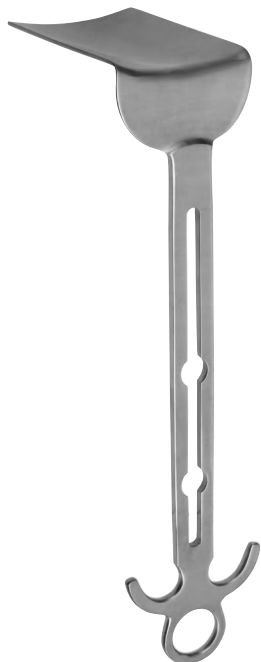

BALFOUR

016-756-100 100x60 mm

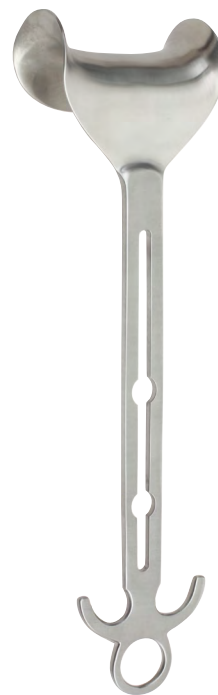

BALFOUR

016-758-001 45x80 mm
016-758-002 68x85 mm



016

Bauchdeckenhalter
Abdominal Retractors
Separadores abdominales
Divaricatori addominali

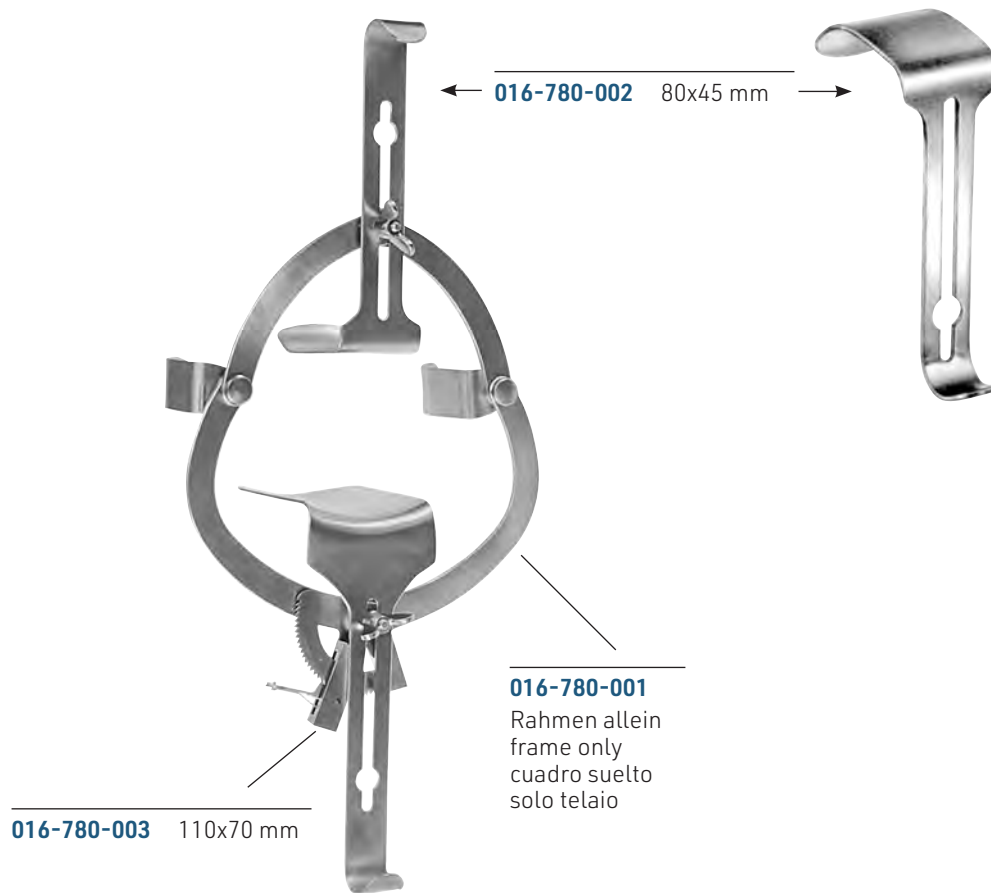

O`SULLIVAN-O`CONNOR

016-780-000

komplett, complete, completo, completo

1 x 016-780-001

2 x 016-780-002

1 x 016-780-003

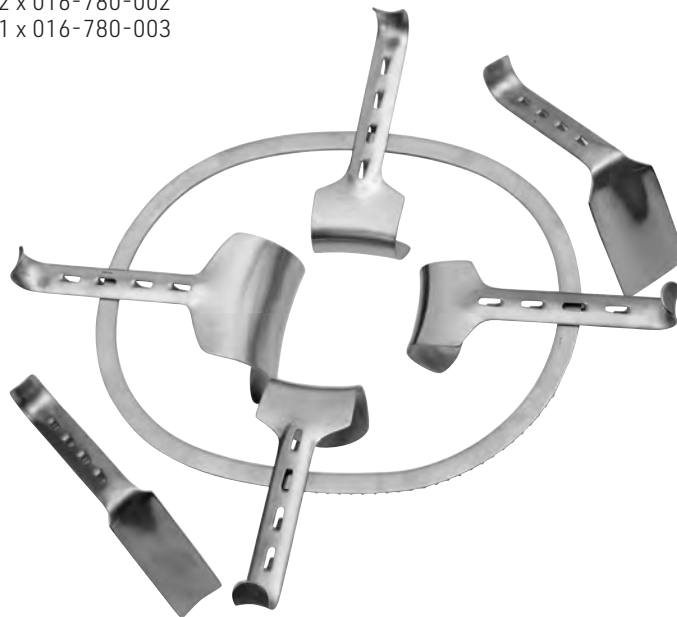

KIRSCHNER

016-800-000

komplett, complete, completo, completo

1 x 016-800-001

3 x 016-811-002

1 x 016-811-003

1 x 016-813-001

1 x 016-813-002

016-800-001 300 x 240 mm

Rahmen allein

frame only

cuadro suelto

telaio solo

016-811-002 50x65 mm

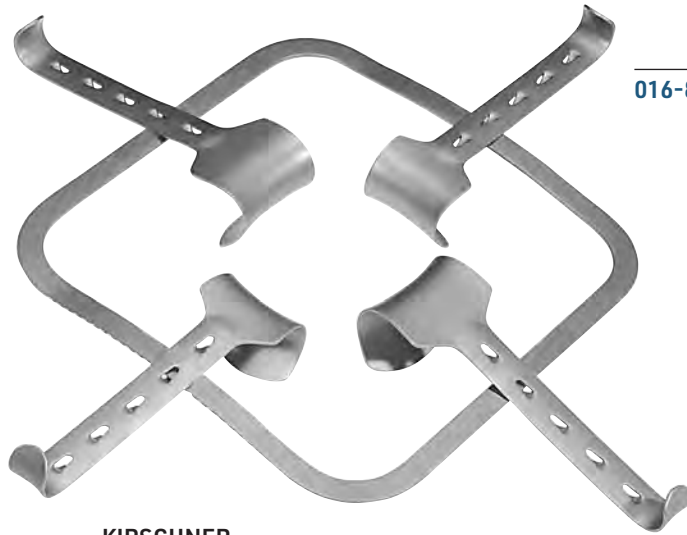

016-811-001 40x55 mm

016-810-001 240x240 mm

Rahmen allein
 frame only
 cuadro suelto
 telaio solo

KIRSCHNER

016-810-000

komplett, complete, completo, completo
 1 x 016-810-001
 2 x 016-811-001
 2 x 016-811-002



KIRSCHNER

016-811-003 80x90 mm
016-811-004 90x65 mm



KIRSCHNER

016-811-005 60x85 mm



KIRSCHNER-BALFOUR

016-811-010 80x80 mm



KIRSCHNER

016-813-001 98x50 mm
016-813-002 105x35 mm



KIRSCHNER

016-814-000 270x270 mm
 komplett, complete, completo, completo
 1 x 016-814-001
 2 x 016-811-001
 2 x 016-811-002

016-814-001 270x270 mm

zusammenlegbarer Rahmen, allein
 folding frame, only
 cuadro plegable, suelto
 telaio pieghevole, solo



016

Bauchdeckenhalter
Abdominal Retractors
Separadores abdominales
Divaricatori addominali

016-820-004 83x94 mm

016-820-005 45x57 mm

016-820-001 275x250 mm

Rahmen allein
frame only
cuadro suelto
telaio solo

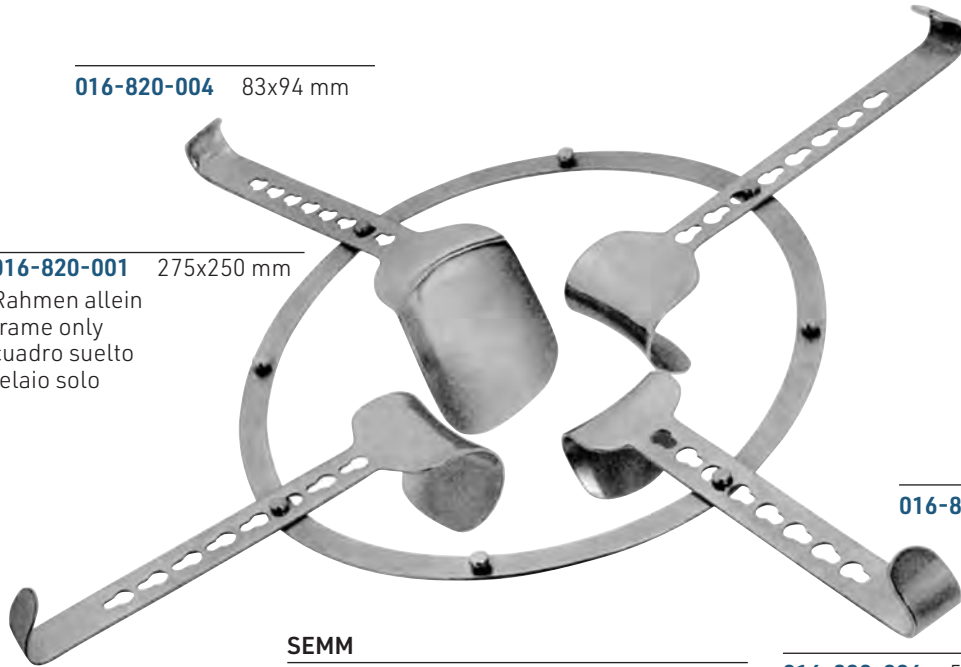

016-820-002 98x50 mm

016-820-003 105x35 mm

SEMM

016-820-000

komplett, complete, completo, completo

1 x 016-820-001

1 x 016-820-002

1 x 016-820-003

1 x 016-820-004

2 x 016-820-005

1 x 016-820-006

016-820-006 50x54 mm

016-832-004 40x40 mm

016-832-003 40x30 mm

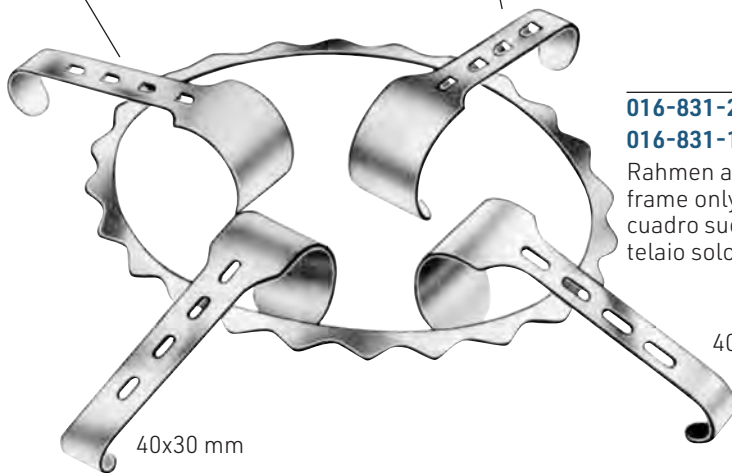

016-831-255 255x180 mm

016-831-150 150x180 mm

Rahmen allein
frame only
cuadro suelto
telaio solo

40x40 mm

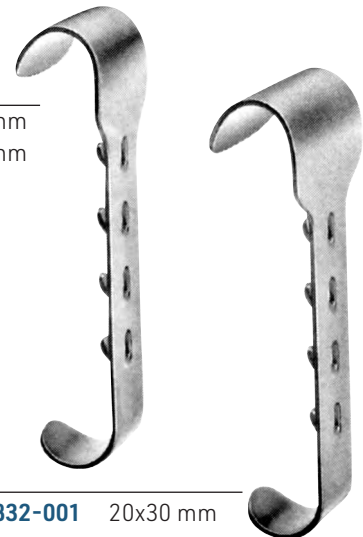

016-832-001 20x30 mm

016-832-002 20x40 mm

DENIS-BROWNE

016-830-150

1 x 016-831-150

2 x 016-832-003

2 x 016-832-004

DENIS-BROWNE

016-830-255

1 x 016-831-255

2 x 016-832-003

2 x 016-832-004

016-840-004 40x60 mm

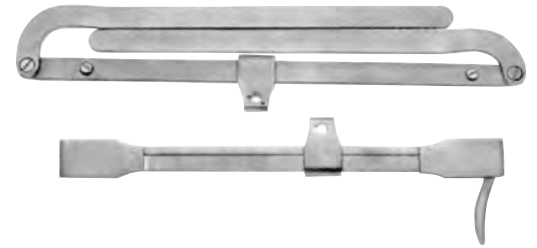
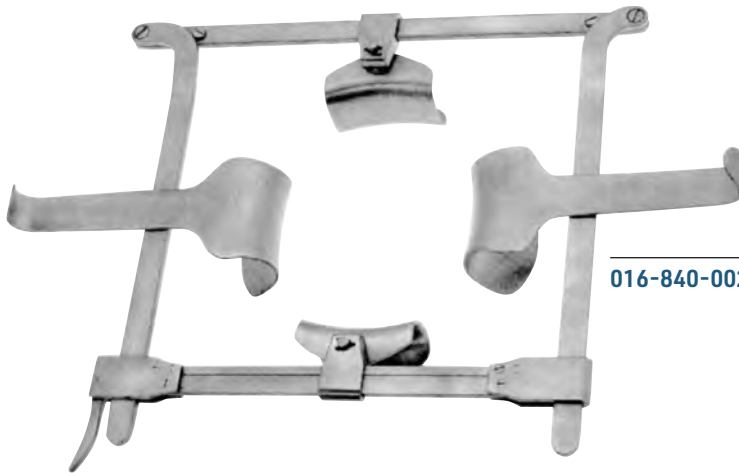

016-840-002 48x56 mm

016-840-001 220x220 mm
 zusammenlegbarer Rahmen, allein
 folding frame, only
 cuadro plegable, suelto
 telaio piegabile, solo

FRANZ

016-840-000

komplett, complete, completo, completo

- 1 x 016-840-001
- 2 x 016-840-002
- 2 x 016-840-004

FRANZ

016-842-000

komplett, complete, completo, completo

- 1 x 016-840-001
- 2 x 016-840-002
- 2 x 016-840-003
- 2 x 016-840-004
- 2 x 016-840-005



016-840-004 40x60 mm
016-840-005 40x80 mm

016-840-002 48x56 mm
016-840-003 50x85 mm



Kette mit Gewicht
 Chain with weight
 Cadena con peso
 Catena con peso

DOYEN

- 016-850-001** 28,0 cm /11" 90x50 mm
- 016-850-002** 28,0 cm /11" 105x50 mm
- 016-850-003** 28,0 cm /11" 120x50 mm
- 016-850-004** 28,0 cm /11" 135x50 mm

016-851-000 79,0 cm /31"



016

Bauchdeckenhalter
Abdominal Retractors
Separadores abdominales
Divaricatori addominali



ROCHARD
016-860-000



ROCHARD
016-870-000



ROCHARD
016-871-001 19,0 cm /11"

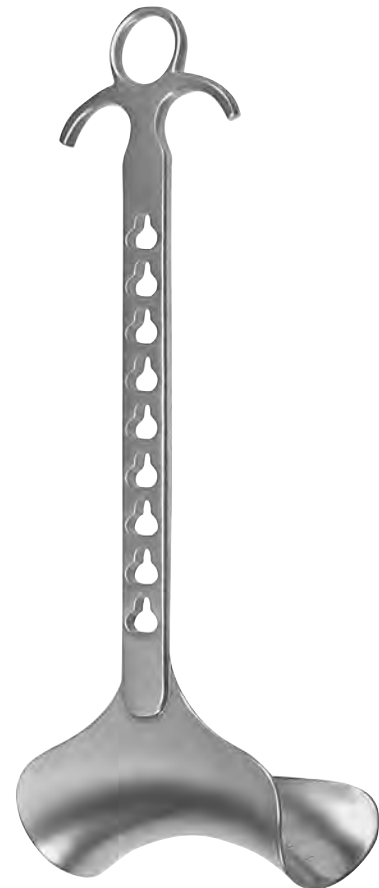

ROCHARD		
016-871-002	28,0 cm /11"	95x50 mm
016-871-003	28,0 cm /11"	105x50 mm
016-871-004	28,0 cm /11"	120x60 mm
016-871-005	28,0 cm /11"	135x60 mm
016-871-006	28,0 cm /11"	155x60 mm

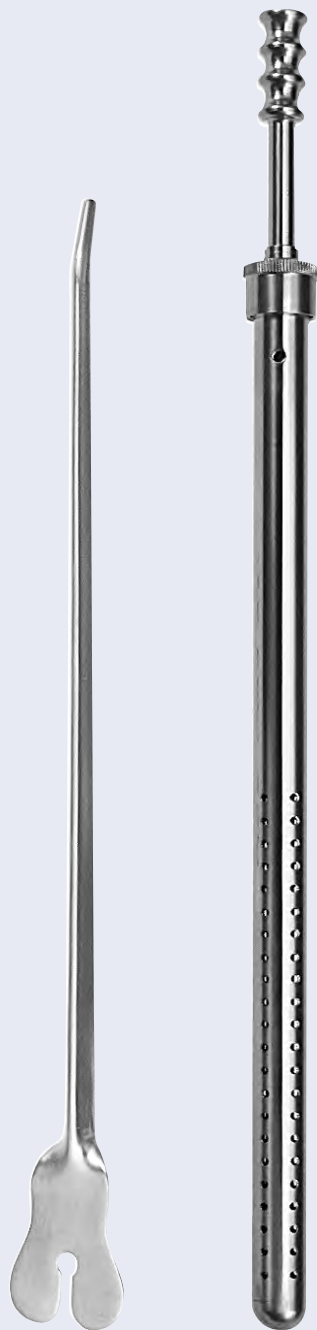

017

Sonden, Aspiration
Probes, Aspiration
Sondas, Aspiración
Sonde, Aspirazione



017

Sonden
Probes
Sondas
Sonde



ø 1,0 mm	ø 1,5 mm	ø 2,0 mm	
017-010-115	017-012-115	017-014-115	11,5 cm / 4 ¹ / ₂ "
017-010-130	017-012-130	017-014-130	13,0 cm / 5"
017-010-145	017-012-145	017-014-145	14,5 cm / 5 ³ / ₄ "
017-010-160	017-012-160	017-014-160	16,0 cm / 6 ¹ / ₄ "
017-010-180	017-012-180	017-014-180	18,0 cm / 7"
017-010-200	017-012-200	017-014-200	20,0 cm / 8"
	017-012-250	017-014-250	25,0 cm / 9 ³ / ₄ "
		017-014-300	30,0 cm / 11 ³ / ₄ "

ø 2,0 mm	
017-020-115	11,5 cm / 4 ¹ / ₂ "
017-020-130	13,0 cm / 5"
017-020-145	14,5 cm / 5 ³ / ₄ "
017-020-160	16,0 cm / 6 ¹ / ₄ "
017-020-180	18,0 cm / 7"
017-020-200	20,0 cm / 8"
017-020-250	25,0 cm / 9 ³ / ₄ "

ø 1,0 mm



Silber
Silver
Plata
argento

STACKE

017-030-105 10,5 cm / 4¹/₈"



ø 1,5 mm	ø 2,0 mm	
-	017-040-130	13,0 cm / 5"
017-035-145	017-040-145	14,5 cm / 5 ³ / ₄ "
-	017-040-160	16,0 cm / 6 ¹ / ₄ "
-	017-040-180	18,0 cm / 7"
-	017-040-200	20,0 cm / 8"



ø 3,5 mm	
017-050-115	11,5 cm / 4 ¹ / ₂ "
017-050-130	13,0 cm / 5"
017-050-145	14,5 cm / 5 ³ / ₄ "
017-050-160	16,0 cm / 6 ¹ / ₄ "
017-050-180	18,0 cm / 7"
017-050-200	20,0 cm / 8"



ø 3,3 mm

- 017-060-130** 13,0 cm / 5"
- 017-060-145** 14,5 cm / 5³/₄"
- 017-060-160** 16,0 cm / 6¹/₄"
- 017-060-180** 18,0 cm / 7"
- 017-060-200** 20,0 cm / 8"



DOYEN

- 017-071-145** 14,5 cm / 5³/₄"



NELATON

- 017-073-160** 16,0 cm / 6¹/₄"



BRODIE

- 017-080-200** 20,0 cm / 8"



LOCKHARD-MUMMERY

- 017-090-001** 16,5 cm / 6¹/₂"

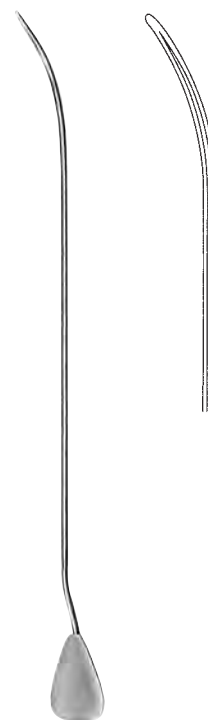

LOCKHARD-MUMMERY

- 017-090-002** 16,5 cm / 6¹/₂"



017

Sonden, Phlebo-dissektor
Probes, Phlebo-dissectors
Sondas, Flebo-dissecadores
Sonde, Flebo-dissettori

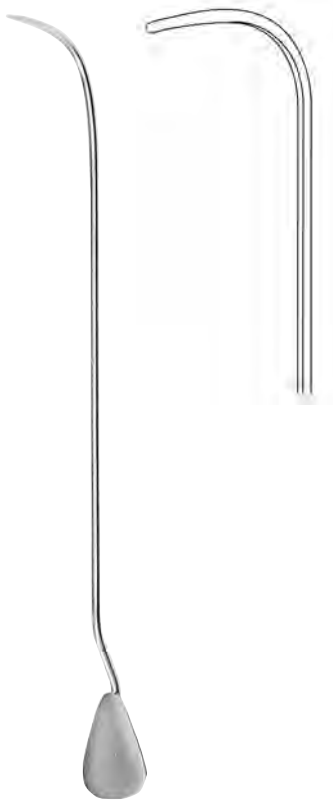

LOCKHARD-MUMMERY

017-090-003 16,5 cm / 6 1/2"



LOCKHARD-MUMMERY

017-090-004 16,5 cm / 6 1/2"

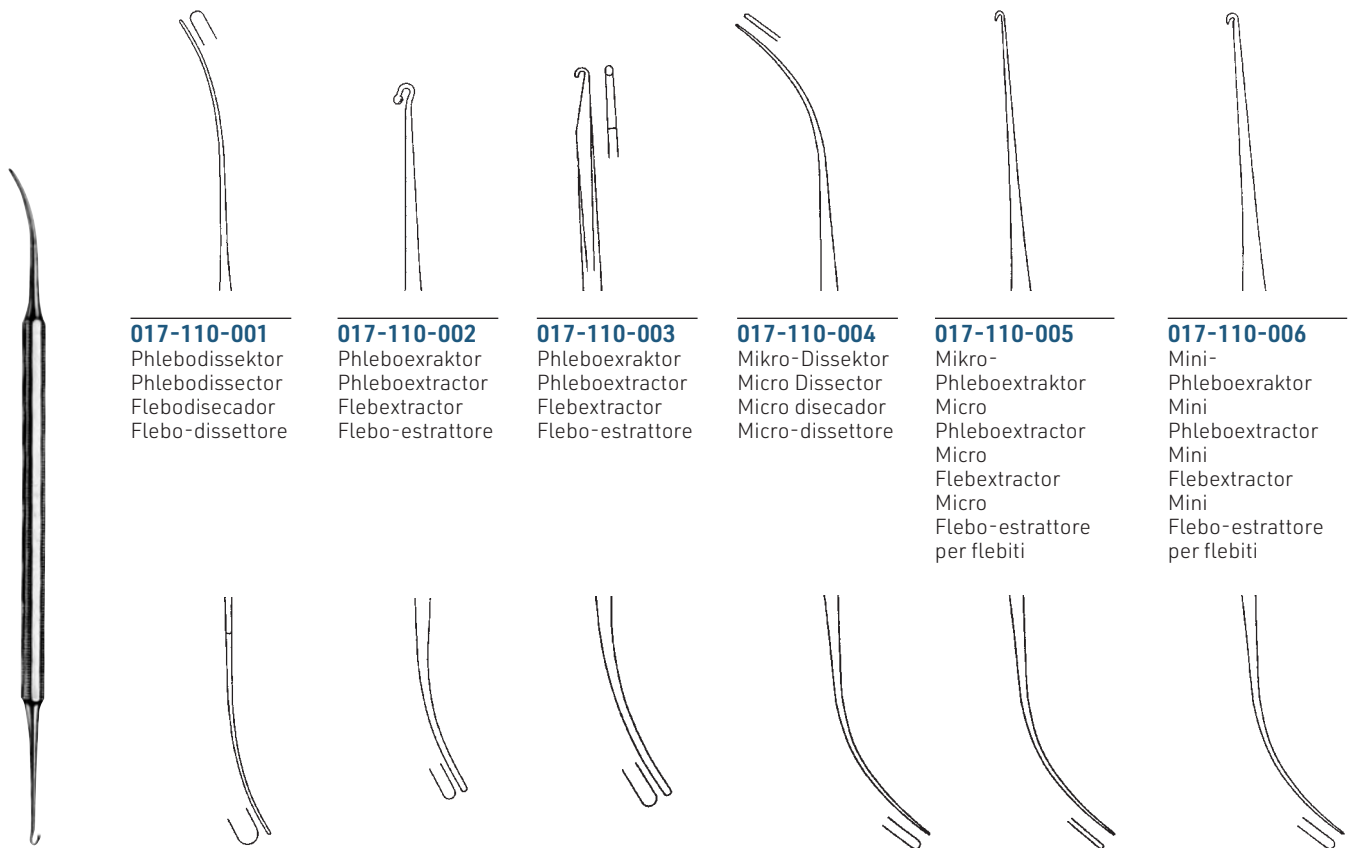

017-110-001
Phlebo-dissektor
Phlebo-dissector
Flebodisecador
Flebo-dissetto

017-110-002
Phleboexraktor
Phleboextractor
Flebextractor
Flebo-estrattore

017-110-003
Phleboexraktor
Phleboextractor
Flebextractor
Flebo-estrattore

017-110-004
Mikro-Dissektor
Micro Dissector
Micro disecador
Micro-dissetto

017-110-005
Mikro-
Phleboexraktor
Micro
Phleboextractor
Micro
Flebextractor
Micro
Flebo-estrattore
per flebiti

017-110-006
Mini-
Phleboexraktor
Mini
Phleboextractor
Mini
Flebextractor
Mini
Flebo-estrattore
per flebiti

VARADY

017-110-001 - 017-110-006 18,0 cm / 7"



017-100-001 135x100x25 mm

Metalletui
 Metal case
 Estuche de metal
 Scatola in metallo

NABATOFF

017-100-000

komplett
 complete
 completo
 completo



017-100-003
 Ø 3,0 mm



017-100-006
 Ø 6,0 mm



017-100-009
 Ø 9,0 mm

017-100-021

Zugseil
 Cable
 Cable
 Fune

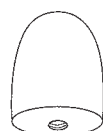
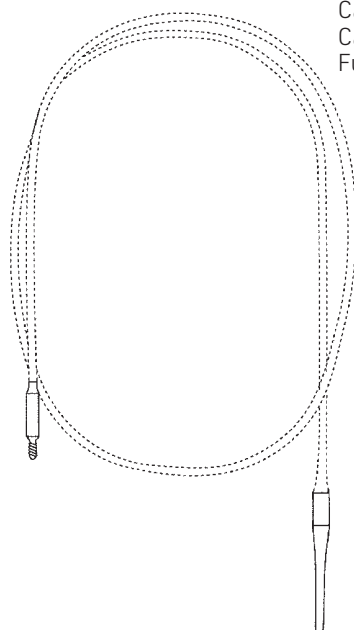

017-100-012
 Ø 12,0 mm



017-100-015
 Ø 15,0 mm

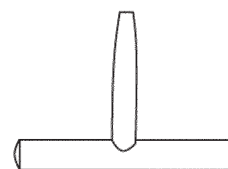

017-100-020

Handgriff
 Handle
 Mango
 Manico

017-100-002

Kunststoff-Sondenspitze
 Plastic probe tip
 Punta de sonda de plastica
 Punta di sonda di plastica



017

Sonden, Phlebotomier
Probes, Phlebotomizers
Sondas, Flebotomizadores
Sonde, Flebo-tomizzatori

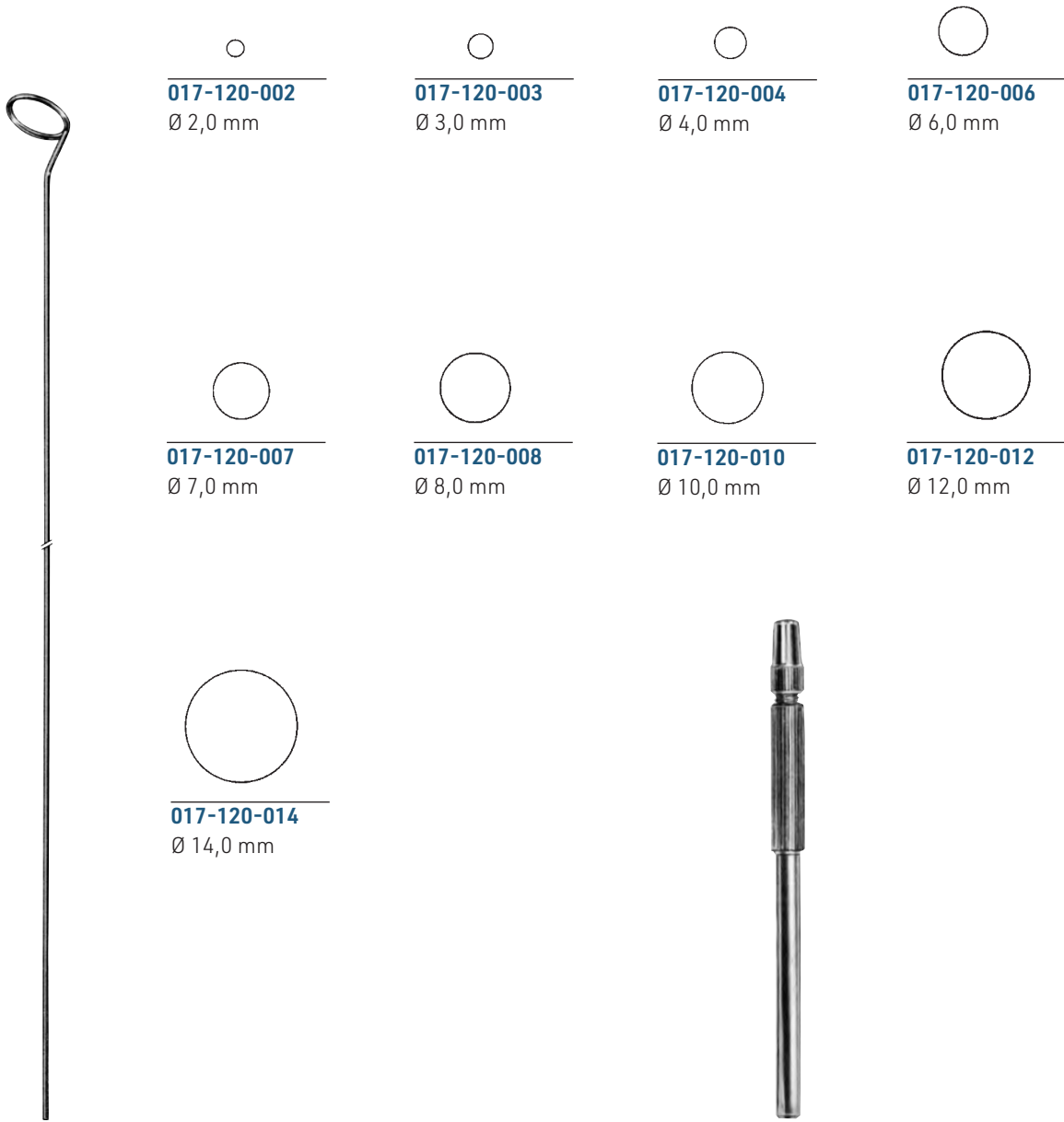

017-120-002
Ø 2,0 mm

017-120-003
Ø 3,0 mm

017-120-004
Ø 4,0 mm

017-120-006
Ø 6,0 mm

017-120-007
Ø 7,0 mm

017-120-008
Ø 8,0 mm

017-120-010
Ø 10,0 mm

017-120-012
Ø 12,0 mm

017-120-014
Ø 14,0 mm

VOLLMAR
017-120-002 - 017-120-012 50 cm / 19³/₄"

017-122-120 12,0 cm / 4³/₈"
Handgriff für Ringstripper nach Vollmar
Handle for Vollmar Ring Stripper
Mango para Vollmar fleboextractor
Manico per stripper anello di Vollmar



JOBSON-HORNE

017-150-180 18,0 cm / 7"



UCKERMANN

017-154-160 16,0 cm / 6 1/4"



FARRELL

017-160-120	Ø 0,9 mm	12,0 cm / 4 3/4"
017-160-140	Ø 0,9 mm	14,0 cm / 5 1/2"
017-160-160	Ø 1,1 mm	16,5 cm / 6 1/2"
017-160-180	Ø 1,2 mm	18,0 cm / 7"



FARRELL

017-170-120	Ø 0,9 mm	12,0 cm / 4 3/4"
017-170-140	Ø 0,9 mm	14,0 cm / 5 1/2"
017-170-160	Ø 1,1 mm	16,5 cm / 6 1/2"
017-170-180	Ø 1,2 mm	18,0 cm / 7"

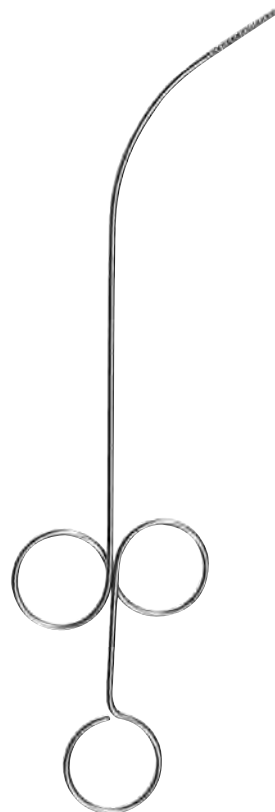

FEIN

017-180-280 28,0 cm / 11"

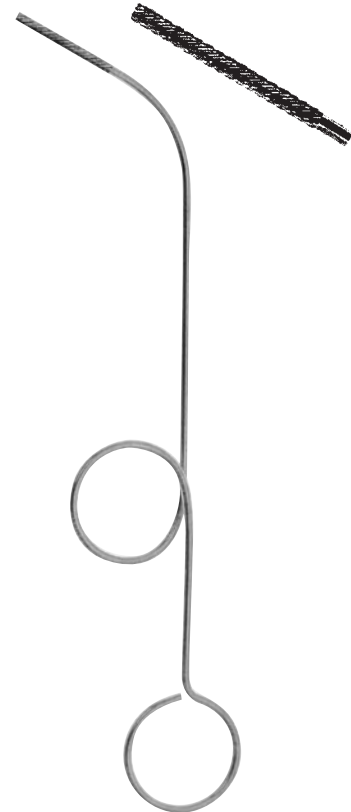

PELTESON

017-184-230 23,0 cm / 9"



017

Trokare
Trocars
Tròcares
Trequarti

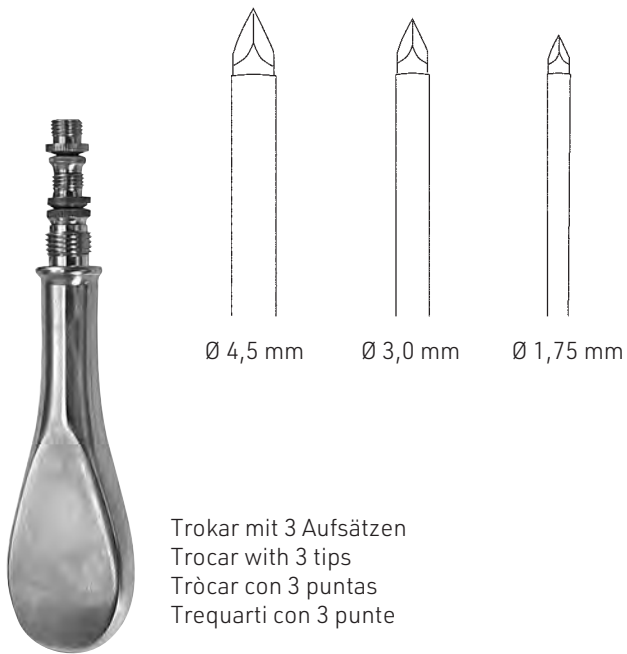

UNIVERSAL
017-200-003

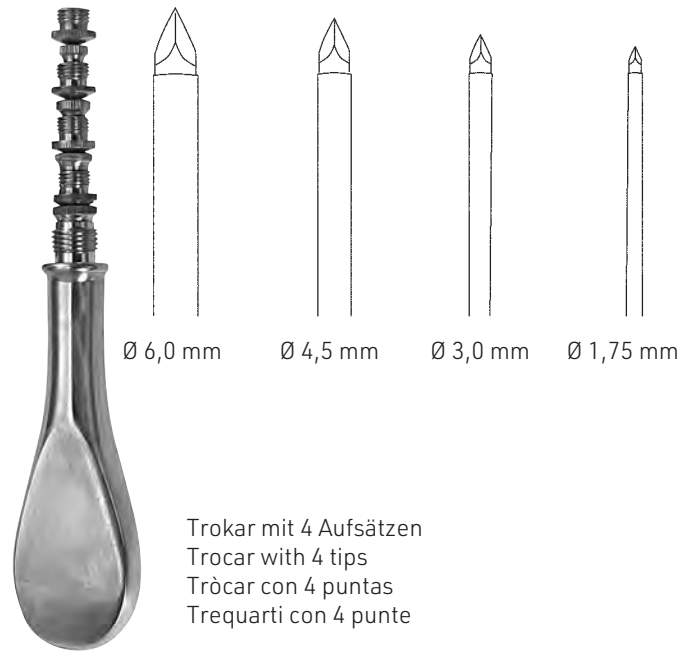

UNIVERSAL
017-200-004



STANDARD

017-210-030	Ø 3,0 mm
017-210-035	Ø 3,5 mm
017-210-040	Ø 4,0 mm
017-210-045	Ø 4,5 mm
017-210-050	Ø 5,0 mm
017-210-055	Ø 5,5 mm
017-210-060	Ø 6,0 mm



NELSON

017-220-075	Ø 7,5 mm
017-220-090	Ø 9,0 mm
017-220-110	Ø 11,0 mm

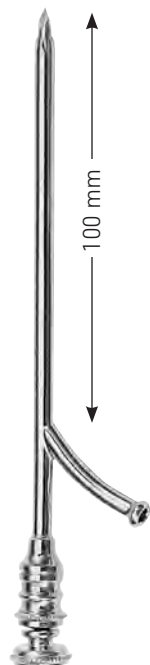

OCHSNER

017-230-040 Ø 4,0 mm
017-230-055 Ø 5,5 mm
017-230-065 Ø 6,5 mm



Kieferhöhlentrokare
Antrum trocars
Trócares para el seno maxilar
Trequarti per puntura del seno
mascellare

LICHTWITZ

017-240-190 19,0 cm / 7 1/2"



DOUGLAS

017-250-110 Ø 3,0 mm



KRAUSE

017-260-040 Ø 4,0 mm
017-260-055 Ø 5,5 mm



PIERCE

017-265-040 Ø 4,0 mm



BUELAU

017-270-080 Ø 8,0 mm



017

Trokare, Saugrohre
Trocars, Suction Tubes
Trócares, Tubos para aspiración
Trequarti, Tubi aspirazione



Ø 2,0 mm

LANDAU

017-280-160 16,0 cm / 6 1/4"



Ø 2,3 mm

COAKLEY

017-290-140 14,0 cm / 5 1/4"



Ø 4,0 mm

ADSON

017-300-210 21,0 cm / 8 1/4"



Ø 3,0 mm

ADSON

017-301-165 16,5 cm / 6 1/2"



FRAZIER

017-310-010 Charr. 10 20,0 cm / 8"



FRAZIER

017-311-006	Charr. 6	19,0 cm / 7 1/2"
017-311-007	Charr. 7	19,0 cm / 7 1/2"
017-311-008	Charr. 8	19,0 cm / 7 1/2"
017-311-009	Charr. 9	19,0 cm / 7 1/2"
017-311-010	Charr. 10	19,0 cm / 7 1/2"
017-311-011	Charr. 11	19,0 cm / 7 1/2"
017-311-012	Charr. 12	19,0 cm / 7 1/2"



POPPE

017-320-006	Charr. 6	13,0 cm / 5"
017-320-008	Charr. 8	13,0 cm / 5"
017-320-010	Charr. 10	13,0 cm / 5"
017-320-012	Charr. 12	13,0 cm / 5"



PLESTER

017-340-015	Ø 1,5 mm	19,5 cm / 7 2/3"
017-340-020	Ø 2,0 mm	19,5 cm / 7 2/3"
017-340-025	Ø 2,5 mm	19,5 cm / 7 2/3"
017-340-030	Ø 3,0 mm	19,5 cm / 7 2/3"



LEMPERT

017-350-020	Ø 2,0 mm	20,0 cm / 8"
017-350-030	Ø 3,0 mm	20,0 cm / 8"



017

Sauginstrumente
Aspirating Instruments
Instrumentos de aspiración
Strumenti per aspirazione



COGSWELL

017-375-230 23,0 cm / 9"



Präpariersauger
Suction raspatory
Aspirador para preparacion
Aspiratore per preparazione

LANDOLT

017-380-200 20,0 cm / 8"

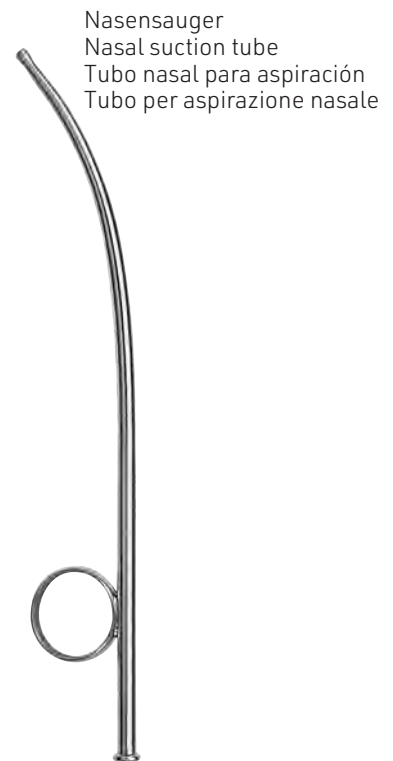

Nasensauger
Nasal suction tube
Tubo nasal para aspiración
Tubo per aspirazione nasale

KILNER

017-390-190 19,0 cm / 7½"



MAGILL

017-400-030	Ø 3,0 mm	24,5 cm / 6,9"
017-400-035	Ø 3,5 mm	24,5 cm / 6,9"
017-400-040	Ø 4,0 mm	24,5 cm / 6,9"

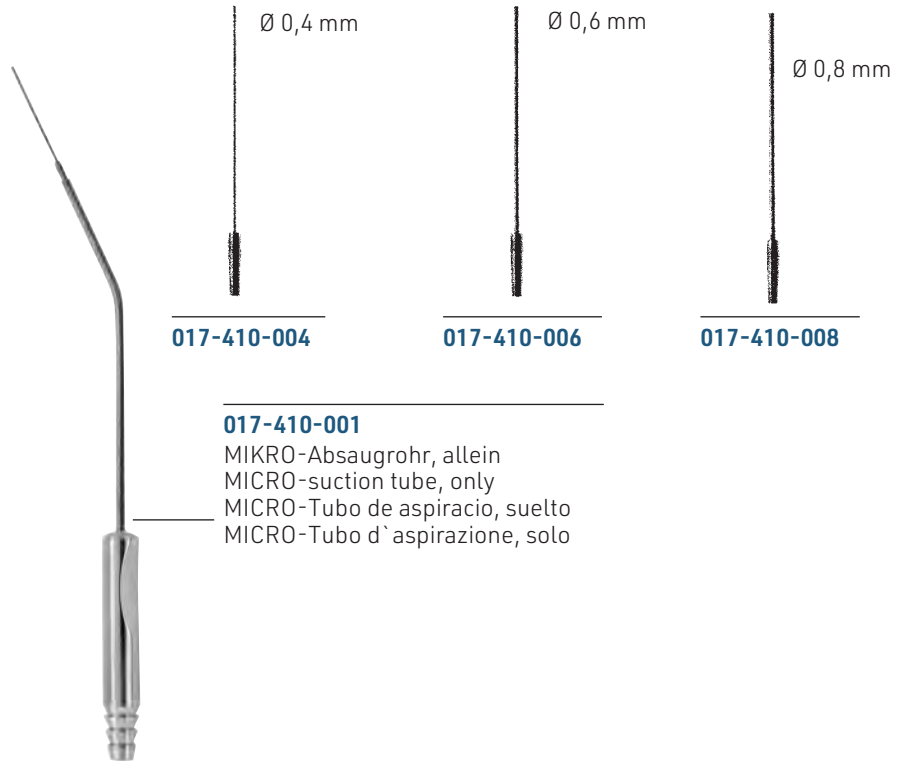

017-410-004

017-410-006

017-410-008

017-410-001

MIKRO-Absaugrohr, allein
MICRO-suction tube, only
MICRO-Tubo de aspiración, suelto
MICRO-Tubo d'aspirazione, solo

WULLSTEIN

017-410-000 17,0 cm / 6³/₄"

Komplett bestehend aus: 1 MIKRO-Absaugrohr mit LUER-Bohrung (017-410-001) und
3 MIKRO-Saugkanülen Ø 0,4 mm - Ø 0,8 mm (017-410-004, -006 und -008)
Complete consisting of: 1 MICRO-Suction tube with LUER hub (017-410-001) and
3 MICRO-Suction cannulas Ø 0,4 mm - Ø 0,8 mm (017-410-004, -006 und -008)
Completo compuesto de: 1 MICRO-Tubo de aspiración con cono LUER (017-410-001) y
3 MICRO-cánulas para aspiración Ø 0,4 mm - Ø 0,8 mm (017-410-004, -006 und -008)
Completo composto da: 1 MICRO-Tubo d'aspirazione, perforazione LUER (017-410-001) e
3 MICRO-cannule d'aspirazione Ø 0,4 mm - Ø 0,8 mm (017-410-004, -006 und -008)

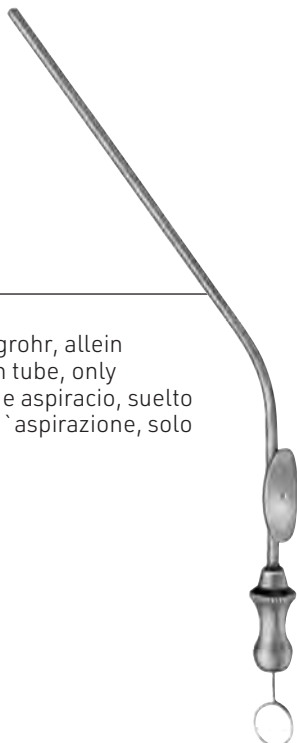

017-420-001

MIKRO-Absaugrohr, allein
MICRO-suction tube, only
MICRO-Tubo de aspiración, suelto
MICRO-Tubo d'aspirazione, solo

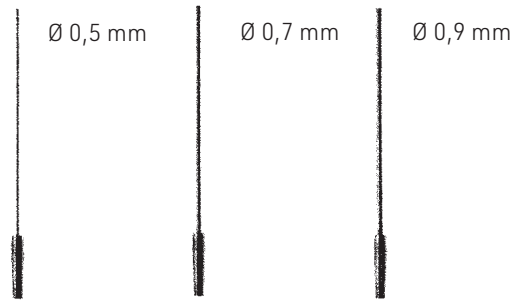

017-420-005

017-420-007

017-420-009

BELLUCCI

017-420-000 15,5 cm / 6"

Komplett bestehend aus: 1 MIKRO-Absaugrohr mit LUER-Bohrung (017-420-001) und
3 MIKRO-Saugkanülen Ø 0,5 mm - Ø 0,9 mm (017-420-005, -007 und -009)
Complete consisting of: 1 MICRO-Suction tube with LUER hub (017-420-001) and
3 MICRO-Suction cannulas Ø 0,5 mm - Ø 0,9 mm (017-420-005, -007 und -009)
Completo compuesto de: 1 MICRO-Tubo de aspiración con cono LUER (017-420-001) y
3 MICRO-Cánulas para aspiración Ø 0,5 mm - Ø 0,9 mm (017-410-005, -007 und -009)
Completo composto da: 1 MICRO-Tubo d'aspirazione, perforazione LUER (017-420-001) e
3 MICRO-Cannule d'aspirazione Ø 0,5 mm - Ø 0,9 mm (017-420-005, -007 und -009)



017

Sauginstrumente
Aspirating Instruments
Instrumentos de aspiración
Strumenti per aspirazione



SCHUKNECHT

017-430-005 Ø 0,5 mm 13,0 cm / 5¹/₈"
017-430-009 Ø 0,9 mm 13,0 cm / 5¹/₈"



BARRON

017-440-010 Ø 1,0 mm 10,0 cm / 4"
017-440-023 Ø 2,3 mm 10,0 cm / 4"



ZÖLLNER

017-451-005 Ø 0,5 mm
017-451-007 Ø 0,7 mm
017-451-009 Ø 0,9 mm
017-451-012 Ø 1,2 mm

ZÖLLNER

017-450-180 18,0 cm / 7"



HOUSE

017-460-009 Ø 0,9 mm / 0,7 mm
017-460-012 Ø 1,2 mm / 0,9 mm
017-460-015 Ø 1,5 mm / 1,2 mm

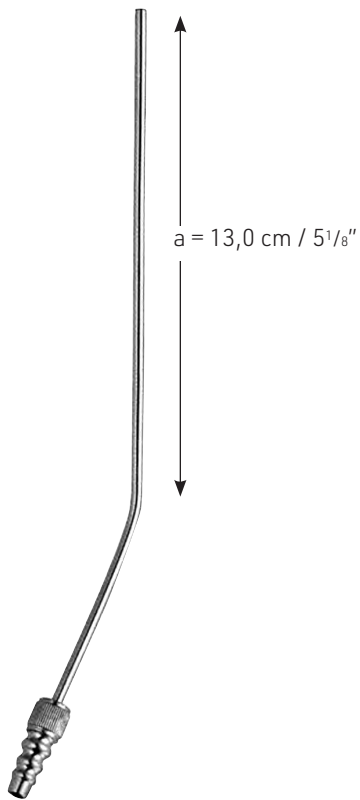

YASARGIL

- 017-470-015 Ø 1,5 mm
- 017-470-020 Ø 2,0 mm
- 017-470-025 Ø 2,5 mm
- 017-470-035 Ø 3,5 mm

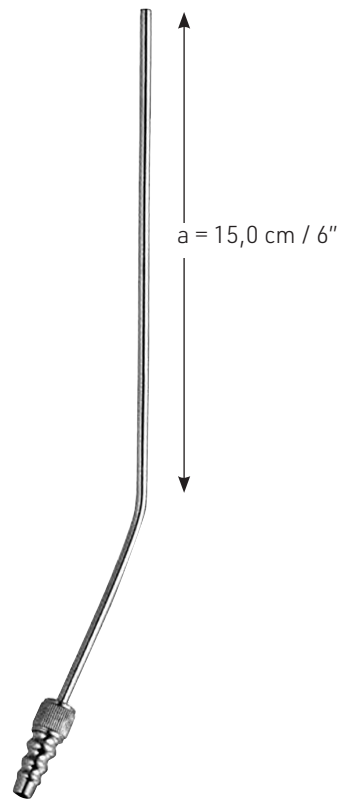

YASARGIL

- 017-472-015 Ø 1,5 mm
- 017-472-020 Ø 2,0 mm
- 017-472-025 Ø 2,5 mm
- 017-472-035 Ø 3,5 mm

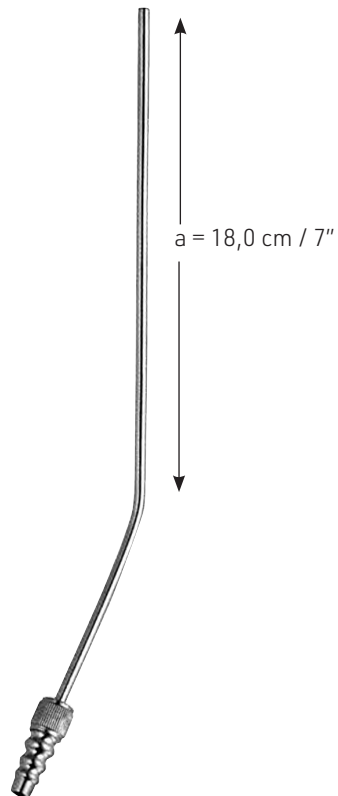

YASARGIL

- 017-474-015 Ø 1,5 mm
- 017-474-020 Ø 2,0 mm
- 017-474-025 Ø 2,5 mm
- 017-474-035 Ø 3,5 mm

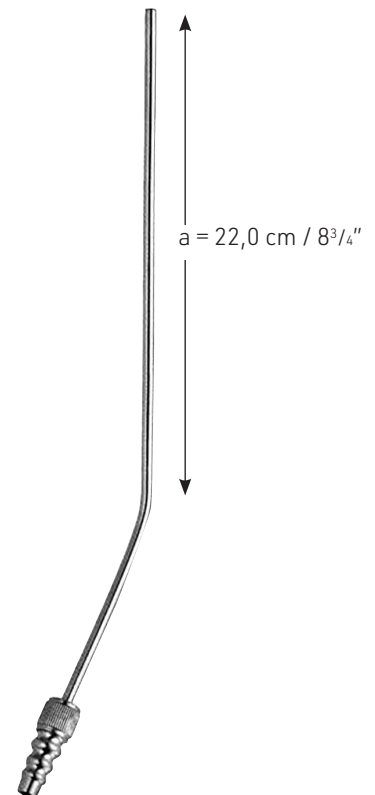

YASARGIL

- 017-476-015 Ø 1,5 mm
- 017-476-020 Ø 2,0 mm
- 017-476-025 Ø 2,5 mm
- 017-476-035 Ø 3,5 mm



017

Saug- und Spülinstrumente
 Aspirating and Irrigating Instruments
 Instrumentos de aspiración y de lavado
 Strumenti per aspirazione e lavaggio



017-480-271
 Saugkopf allein
 Tip head only
 Cabeza de succión sola
 Testa di aspirazione solo

YANKAUER
017-480-270 27,0 cm / 10³/₄"

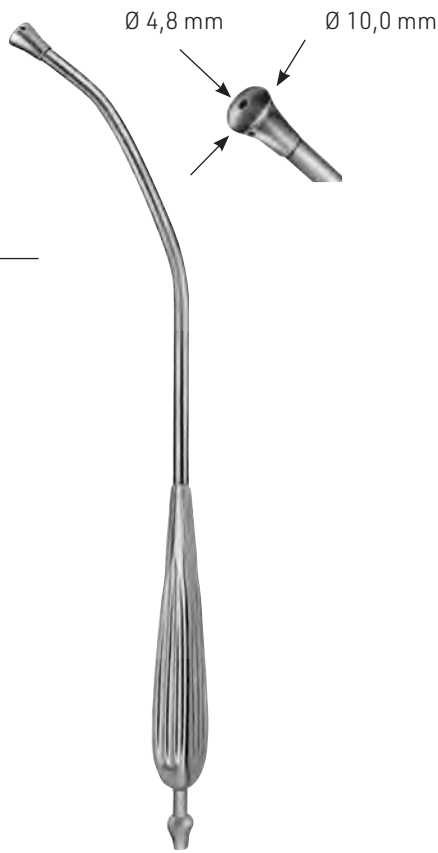

YANKAUER
017-490-285 28,5 cm / 11¹/₄"



ANDREWS-PYNCHON
017-500-240 24,0 cm / 9¹/₂"



POOLE
017-510-220 22,0 cm / 8⁵/₈"

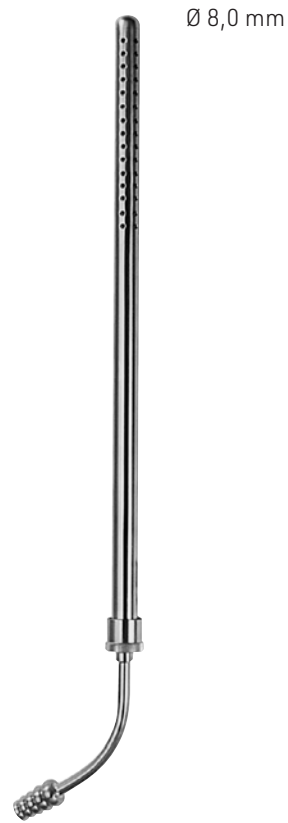

POOLE
017-511-220 22,0 cm / 8⁵/₈"



COOLEY

017-521-350 35,0 cm / 13³/₄"



COOLEY

017-523-300 30,0 cm / 11³/₄"



017-531-035

Ø 3,5 mm



COOLEY

017-525-310 31,0 cm / 11³/₄"



COOLEY

017-527-330 33,0 cm / 13"



COUPLAND

017-530-170

17,0 cm / 6³/₄"



017

Spezialkanülen
Special Needles
Agujas especiales
Aghi speciali



REDON

017-550-008	Charr.8
017-550-010	Charr.10
017-550-012	Charr.12
017-550-014	Charr.14
017-550-016	Charr.16
017-550-018	Charr.18



REDON

017-560-008	Charr.8
017-560-010	Charr.10
017-560-012	Charr.12
017-560-014	Charr.14
017-560-016	Charr.16
017-560-018	Charr.18



REDON

017-570-008	Charr.8
017-570-010	Charr.10
017-570-012	Charr.12
017-570-014	Charr.14
017-570-016	Charr.16
017-570-018	Charr.18



REDON

017-580-008	Charr.8
017-580-010	Charr.10
017-580-012	Charr.12
017-580-014	Charr.14
017-580-016	Charr.16
017-580-018	Charr.18

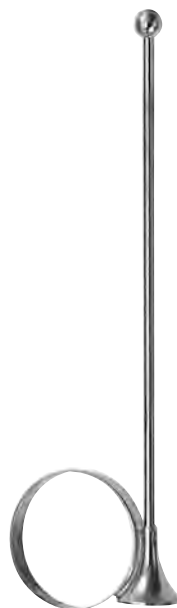

IOWA

017-610-140	14,0 cm / 5 1/4"
--------------------	------------------



017-611-001



017-620-012 Ø 1,20x80 mm
017-620-015 Ø 1,50x80 mm



Kanülen zur Leberblindpunktion
 Liver blind puncture needles
 Aguja para punción ciega del hígado
 Aghi per la punture cieca del fegato

MENGHINI

017-630-001	Ø 1,00x 35 mm
017-630-002	Ø 1,00x 70 mm
017-630-003	Ø 1,20x 70 mm
017-630-004	Ø 1,20x 100 mm
017-630-005	Ø 1,40x 70 mm
017-630-006	Ø 1,40x 100 mm
017-630-007	Ø 1,60x 70 mm
017-630-008	Ø 1,60x 100 mm



QUINKE

017-650-001	Ø 1,20x 76 mm
017-650-002	Ø 1,20x 89 mm
017-650-003	Ø 1,00x 76 mm
017-650-004	Ø 1,00x 89 mm
017-650-005	Ø 0,70x 76 mm
017-650-007	Ø 0,70x 89 mm



Kanülen zur Lumbalpunktion
 Lumbar puncture needles
 Aguja para punción lumbar
 Aghi per punture lombari

MENGHINI

017-640-014	Ø 1,40x168 mm
017-640-018	Ø 1,80x168 mm



017

Spezialkanülen
Special Needles
Agujas especiales
Aghi speciali

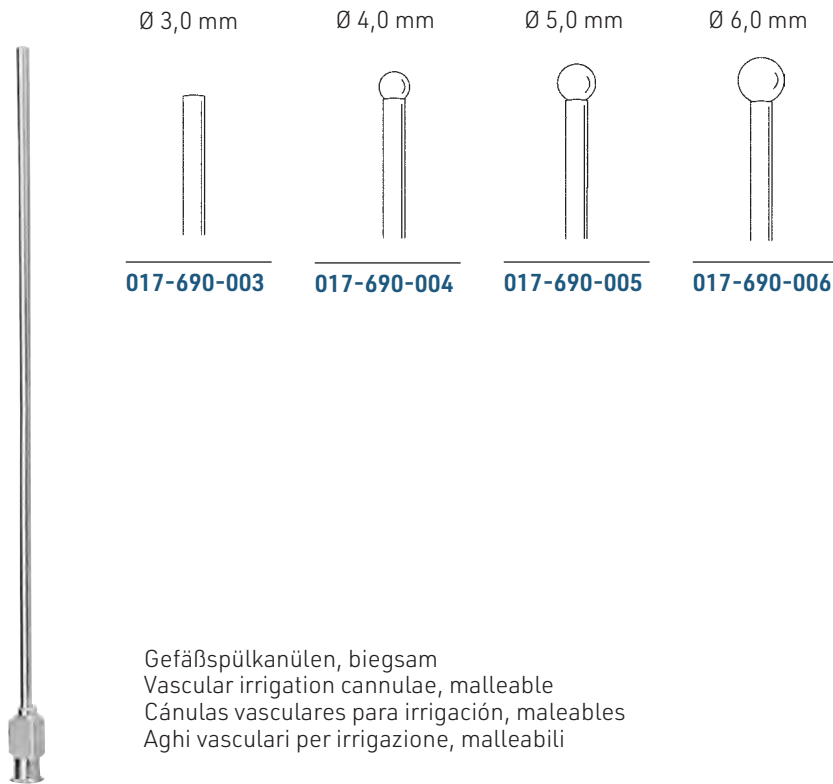

Gefäßspülkanülen, biegsam
Vascular irrigation cannulae, malleable
Cánulas vasculares para irrigación, maleables
Aghi vascolari per irrigazione, malleabili

SCHMID

017-690-003 - 017-690-006 15,0 cm / 6"

Verbindungsstücke, Hähne
Connecting Pieces, Stopcocks
Piezas de conexión, Llaves
Raccordi, Rubinetti



017-760-006 Ø 6 mm
017-760-008 Ø 8 mm

Zwischenstück, LUER-LOCK männlich
Connecting piece, LUER-LOCK male
Pieza de conexión, LUER-LOCK masculino
Raccordo, LUER-LOCK maschio



LUER

017-800-001	1 ml
017-800-002	2 ml
017-800-005	5 ml
017-800-010	10 ml
017-800-020	20 ml
017-800-050	50 ml



LUER-LOCK

017-810-001	1 ml
017-810-002	2 ml
017-810-005	5 ml
017-810-010	10 ml
017-810-020	20 ml
017-810-050	50 ml



LUER-LOCK

017-820-002	2 ml
017-820-005	5 ml
017-820-010	10 ml



017-801-001	1 ml
017-801-002	2 ml
017-801-005	5 ml
017-801-010	10 ml
017-801-020	20 ml
017-801-050	50 ml



017-811-001	1 ml
017-811-002	2 ml
017-811-005	5 ml
017-811-010	10 ml
017-811-020	20 ml
017-811-050	50 ml



017-821-002	2 ml
017-821-005	5 ml
017-821-010	10 ml



017

Spritzen, Ersatzzylinder
Syringes, Spare barrel
Jeringas, Cilindro de repuesto
Siringhe, Cilindro di ricambio



TUBERKULIN LUER LOCK

017-840-001 1 ml



JANET

017-850-050 50 ml
017-850-100 100 ml
017-850-150 150 ml
017-850-200 200 ml



LUER-LOCK

017-860-010 10 ml
017-860-020 20 ml
017-860-030 30 ml
017-860-050 50 ml



017-841-001 1 ml



017-851-050 50 ml
017-851-100 100 ml
017-851-150 150 ml
017-851-200 200 ml



017-861-010 10 ml
017-861-020 20 ml
017-861-030 30 ml
017-861-050 50 ml

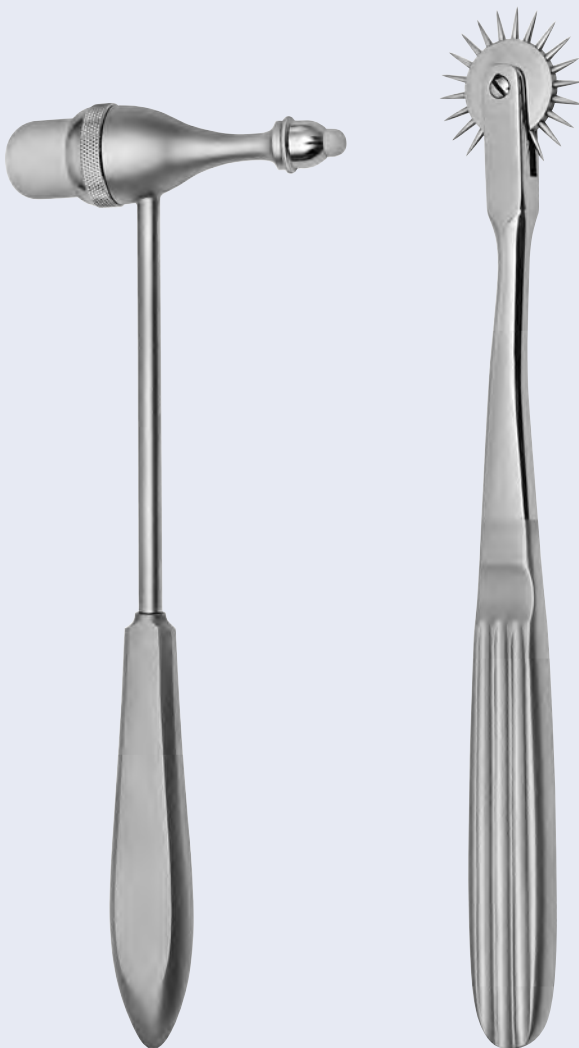

018

Diagnostik, Narkose
Diagnostics, Anaesthesia
Diagnóstico, Anestesia
Diagnóstica, Anestesia



018

Perkussionshämmer
Percussion Hammers
Martillos para reflejos
Martelli percussori



TROEMMER
018-100-240 24,0 cm / 9 1/2"



DEJERINE
018-110-200 20,0 cm / 8"



DEJERINE
018-120-210 21,0 cm / 8 1/4"
mit Nadel
with needle
con aguja
con ago



TAYLOR
018-130-180 18,0 cm / 7"
018-130-200 20,0 cm / 8"



BERLINER
018-140-170 17,0 cm / 6 3/4"
018-140-200 20,0 cm / 8"



BABINSKI
018-150-220 22,0 cm / 8³/₄"



BABINSKI
018-152-220 22,0 cm / 8³/₄"

mit Nadel
 with needle
 con aguja
 con ago



RABINER
018-160-230 23,0 cm / 9"

mit Nadel und Pinsel
 with needle and pencil
 con aguja y pincel
 con ago e pennello



BUCK
018-170-180 18,0 cm / 7"

mit Nadel und Pinsel
 with needle and pencil
 con aguja y pincel
 con ago e pennello



BUCK
018-172-180 18,0 cm / 7"

Teleskopgriff
 telescope handle
 mango telescópico
 manico telescopico

mit Nadel und Pinsel
 with needle and pencil
 con aguja y pincel
 con ago e pennello



Algesimeter
 Pinwheel
 Rueda de espigas
 Algesimetro

WARTENBERG

018-200-190 19,0 cm / 7 1/2"



Holz
 Wooden
 Madera
 Legno

PINARD

018-210-180 18,0 cm / 7"



Aluminium
 Aluminium
 Aluminio
 Alluminio

PINARD

018-220-150 15,0 cm / 6"



FRIMED VIGORIMETER

018-280-000

018-280-003

Ersatz-Gummibälle
 Spare Rubber Balls
 Peras de goma
 Palloni di ricambio

Satz mit 3 Größen
 Set with 3 sizes
 Juego con 3 tamaños
 Set in 3 misure

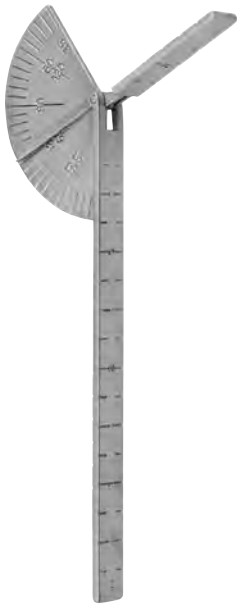

CAROLL
018-300-140 14,0 cm / 5 1/2"



MOELTGEN
018-310-000 23,0 cm / 9"



BERTILLON
018-320-000 32,0 cm / 12 1/3"

mit KG-Einteilung für Erwachsene
 with kilogram scale for adults
 con graduacion en kgs para adultos
 con graduazione in kg per adulti



COLLIN
018-330-110 11,0 cm / 4 3/8"

mit lbs-Einteilung für Erwachsene
 with lbs scale for adults
 con graduacion en lbs para adultos
 con graduazione in lbs per adulti



COLLIN
018-331-110 11,0 cm / 4 3/8"



018-380-150 150 mm
018-380-200 200 mm
018-380-300 300 mm
018-380-500 500 mm



018

Diagnostik-Bestecke
Diagnostic-Sets
Juegos para diagnóstica
Sets per diagnostica



OTOSKOP BESTECK
018-400-000

Otoskopbesteck komplett in Etui bestehend aus:

- 1 Griff Typ C für 2 Batterien oder 1 Accu (ohne Batterien/Accu)
- 1 Otoskopkopf mit Halogenbirne 2,5 V
- je 1 wiederverwendbarer Ohrtrichter ø 2,0 mm, 3,0 mm, 4,0 mm und 5,0 mm, schwarz
- je 3 Einwegohrtrichter ø 2,0 mm und 4,0 mm, blau
- 1 Operationslinse, 4-fach vergrößernd
- 1 Ersatzbirnchen, Halogen 2,5 V

- Otoskopkopf aus robustem Kunststoff
- Fiberoptik für optimale Bündelung und Leitung des Lichts
- Nach beiden Seiten schwenkbare Glasoptik mit 3-fach Vergrößerung
- Operationslinse mit 4-fach Vergrößerung und Miniaturoptik aus Glas für erleichterte Instrumentenführung
- Mit einfach zu bedienender Spekula-Abwurfvorrichtung
- Mit Trichteraufnahme für Spekula und vergrößerter Durchgangsöffnung für Instrumente
- Geeignet zur Durchführung pneumatischer Tests (Lieferung ohne Ball)

Juego para Otoscopia completo en estuche compuesto de:

- 1 mango de pilas tipo C (sin pilas)
- 1 cabeza de otoscopio con bombilla de halógeno 2,5 V
- 1 de c. u. espéculos auriculares reutilizables ø 2,0 mm, 3,0 mm, 4,0 mm y 5,0 mm, negros
- 3 de c. u. espéculos auriculares desechables ø 2,0 mm y 4,0 mm, azules
- 1 lente para operaciones, aumento 4 x
- 1 bombilla de repuesto, halógena 2,5 V

- Cabeza de otoscopio de plástico robusto
- Fibra óptica para una focalización y conducción óptima de la luz
- Óptica de vidrio de 3 aumentos, orientable hacia ambos lados
- Lupa quirúrgica de 4 aumentos, con óptica miniaturizada para facilitar la inserción de los instrumentos
- Con expulsión de espéculos de uso fácil
- Con acogimiento para espéculos y mayor abertura de acceso para instrumentos
- Adecuado para realizar pruebas neumáticas (se suministra sin la pera)

Otoscope Set complete in case consisting of:

- 1 battery handle type C (without batteries)
- 1 otoscope head with halogen bulb 2,5 V
- 1 each reusable ear specula ø 2,0 mm, 3,0 mm, 4, mm and 5,0 mm black
- 3 each disposable ear specula ø 2,0 mm and 4,0 mm, blue
- 1 magnifying lens for operations 4 x
- 1 spare bulb, halogen, 2,5 V

- Otoscope head made of robust plastic material
- Fiberoptics for optimal beaming and transmission of the light
- Bi-directional swivelling optical glass with 3-fold magnification
- Operation lens with 4-fold magnification and glass mini optic ease the insertion of instruments
- Easy-to-operate specula ejection device
- Fitting for specula and enlarged conduit for instruments
- Suitable for pneumatic tests (supplied without ball)

Set per Otoscopia completo in astuccio composto de:

- 1 manico per pila tipo C (senza pila)
- 1 testa di otoscopio con lampadina alogena 2,5 V
- 1 ognuno specchio auricolare riutilizzabile ø 2,0 mm, 3,0 mm, 4,0 mm e 5,0 mm, nero
- 3 ognuno specoli auricolari monouso ø 2,0 mm e 4,0 mm azzurro
- 1 lente per operazione ingrandimento 4 x
- 1 lampadina di ricambio, alogena 2,5V

- Testa di otoscopio di materia plastica robusta
- Fibra ottica per raggianti e conduzione ottimale della luce
- Ottica di vetro da 3 ingrandimento, in due lati orientabile
- Lente per operazione da 4 ingrandimento, con ottica di vetro minimizza per facilitare la introduzione delle strumenti
- Con espulsione degli specoli da uso facile
- Con accoglienza per specoli è ingrandiva apertura del accesso per strumenti
- Appropriato per realizzare test pneumatico (consegna senza pallone)



OPHTHALMOSKOP-BESTECK

018-410-000

Ophthalmoskopbesteck komplett in Etui bestehend aus:

- 1 Griff Typ C für 2 Batterien oder 1 Accu (ohne Batterien/Accu)
- 1 Ophthalmoskop mit Halogenbirne 2,5 V
- 1 Lupe, 5-fach vergrößernd
- 1 Ersatzbirnchen, Halogen, 2,5 V

- Ophthalmoskopkopf aus robustem Kunststoff
- Dioptrienscheibe mit 29 Korrekturlinsen
Plus 1-10, 12, 15, 20, 40
Minus 1-10, 15, 20, 25, 30, 35
- Mit leicht bedienbarem Blendenstellrad mit Halbmond, kleiner/mittlerer/großer Kreisblende, Fixierstern und Schlitz
- Inklusive zu allen Blenden zuschaltbares Filterrad mit Symbolanzeige, Rotfreifilter, Blaufilter und Polarisationsfilter
- Optimierte Hochleistungsoptik mit asphärischer Kondensorlinse
- Paralleler Strahlengang
- Staubgeschützt

Juego para oftalmología completo en estuche compuesto de:

- 1 mango de pilas tipo C (sin pilas)
- 1 oftalmoscopio con bombilla de halógeno 2,5 V
- 1 lupa, aumento 5x
- 1 bombilla de repuesto, halógeno 2,5 V

- cabeza de oftalmoscopio de plástico robusto
- Ruedecilla de lentes con 29 lentes correctoras
D+ 1-10, 12, 15, 20, 40
D- 1-10, 15, 20, 25, 30, 35
- Con ruedecilla de diafragmación de fácil uso, diafragma circular pequeño/mediano/grande, estrella de fijación y rendija
- Incluye una rueda de filtros aplicable a todos los diafragmas con indicador de símbolos, filtro azul, de polarización y exento de rojo
- Óptica de alto rendimiento con lente condensadora esférica
- Trayectoria paralela del haz
- Protección contra el polvo

Ophthalmoscope Set complete in case consisting of:

- 1 battery handle Type C (without batteries)
- 1 ophthalmoscope with halogen bulb 2,5 V
- 1 magnifying lens, 5x
- 1 spare bulb, halogen 2,5 V

- ophthalmoscope head made of robust plastic material
- Diopter wheel with 29 corrective lenses
Plus 1-10, 12, 15, 20, 40
Minus 1-10, 15, 20, 25, 30, 35
- Easy-to-operate aperture hand-wheel with semi-circle, small/medium/large circle, fixation star and slit
- Includes filter wheel engageable for all apertures with symbol display, red-free filter, blue filter and polarization filter
- Optimized high-performance optics with aspherical condenser lens
- Parallel beam path
- Dust-proof

Set per oftalmologia completo in astuccio composto da:

- 1 manico per pila tipo C (senza pila)
- 1 oftalmoscopio con lampadina alogena 2,5 V
- 1 lente, ingrandimento 5x
- 1 lampadina di ricambio, alogena 2,5 V

- testa di oftalmoscopio di materia plastica robusta
- Carrucola da lente con 29 lenti correttive
D+ 1-10, 12, 15, 20, 40
D- 1-10, 15, 20, 25, 30, 35
- Con carrucola da diaframma e semicerchio da uso facile, diaframma circolare piccolo/medio/largo stella per fissare e fessura
- Include carrucola da filtri appropriato a tutti diaframma con indicatore da simboli, filtri azzurro, di polarizzazione e libero da rosso
- Ottica di alto rendimento con lente condensadora asferica
- Percorso di raggio parallelo
- Protezione contra il polvere



018

Diagnostik-Bestecke
Diagnostic-Sets
Juegos para diagnóstica
Sets per diagnóstica



KOMBINATIONS-BESTECK

018-430-000

Diagnostikbesteck kombiniert, komplett in Etui bestehend aus:

- 1 Griff Typ C für 2 Batterien oder 1 Accu (ohne Batterien/Accu)
- 1 Ophthalmoskop mit Halogenbirne 2,5 V
- 1 Otoskopkopf mit Halogenbirne 2,5 V
- je 1 wiederverwendbarer Ohrtrichter ø 2,0 mm, 3,0 mm, 4,0 mm und 5,0 mm, schwarz
- je 3 Einwegohrtrichter ø 2,0 mm und 4,0 mm, blau
- 1 Operationslinse, 4-fach vergrößernd
- 2 Ersatzbirnchen, Halogen 2,5 V

Juego Diagnóstico, combinado, completo en estuche compuesto de:

- 1 mango de pilas tipo C (sin pilas)
- 1 oftalmoscopio con bombilla de halógeno 2,5 V
- 1 cabeza de otoscopio con bombilla de halógeno 2,5 V
- 1 de c. u. espéculos auriculares reutilizables ø 2,0 mm, 3,0 mm, 4,0 mm y 5,0 mm, negros
- 3 de c. u. espéculos auriculares desechables ø 2,0 mm y 4,0 mm, azules
- 1 lente para operaciones, aumento 4 x
- 2 bombillas de repuesto, halógeno 2,5 V

Diagnostic Set, combined, complete in case consisting of:

- 1 battery handy (without batteries)
- 1 ophthalmoscope with halogen bulb 2,5 V
- 1 otoscope head with halogen bulb 2,5 V
- 1 each reusable ear specula ø 2,0 mm, 3,0 mm, 4,0 mm and 5,0 mm, black
- 3 each disposable ear specula ø 2,0 mm and 4,0 mm, blue
- 1 magnifying lens for operations, 4 x
- 2 spare bulb, halogen 2,5 V

Set per diagnostica, combinato, completo in astuccio composto da:

- 1 manico per pila tipo C (senza pila)
- 1 oftalmoscopio con lampadina alogena 2,5 V
- 1 testa di otoscopio con lampadina alogena 2,5 V
- 1 ognuno specoli auricolari riutilizzabili ø 2,0 mm, 3,0 mm, 4,0 mm e 5,0 mm, nero
- 3 ognuno specoli auricolari ø 2,0 mm e 4,0 mm, azzurro
- 1 lente per operazione, ingrandimento 4 x
- 2 lampadina di ricambio, alogena 2,5 V



Packung á 100 St.
 Package of 100 pcs.
 Paquete de 100 piezas
 Confezione da 100 pezzi



Packung á 10 St.
 Package of 10 pcs.
 Paquete de 10 piezas
 Confezione da 10 pezzi

für/for/para/per

018-440-020	Ø 2,0 mm	Ohr/ear/oido/orecchia
018-440-030	Ø 3,0 mm	Ohr/ear/oido/orecchia
018-440-040	Ø 4,0 mm	Ohr/ear/oido/orecchia
018-440-050	Ø 5,0 mm	Ohr/ear/oido/orecchia
018-440-090	Ø 9,0 mm	Nase/nose/nariz/naso

blau zum Einmalgebrauch
 blue disposable
 azul desechable
 azzurro monouso

für/for/para/per

018-441-020	Ø 2,0 mm	Ohr/ear/oido/orecchia
018-441-030	Ø 3,0 mm	Ohr/ear/oido/orecchia
018-441-040	Ø 4,0 mm	Ohr/ear/oido/orecchia
018-441-050	Ø 5,0 mm	Ohr/ear/oido/orecchia
018-441-090	Ø 9,0 mm	Nase/nose/nariz/naso

schwarz wiederverwendbar
 black reusable
 negro reutilizable
 nero riutilizzabile



018-442-001

Batteriehandgriff
 Battery Handle
 Mango de batería
 Manico per pile



Packung á 6 St.
 Package of 6 pcs.
 Paquete de 6 piezas
 Confezione da 6 pezzi

018-443-001

2,5 V

Ersatzbirnchen, Halogen für Otoskop
 Spare bulb, halogen for otoscope
 Bombilla de repuesto, halógeno para otoscopio
 Lampadina di ricambio, alogeno per otoscopio



Packung á 6 St.
 Package of 6 pcs.
 Paquete de 6 piezas
 Confezione da 6 pezzi

018-444-001

2,5 V

Ersatzbirnchen, Halogen für Ophthalmoskop
 Spare bulb, halogen for ophthalmoscope
 Bombilla de repuesto, halógeno para oftalmoscopio
 Lampadina di ricambio, alogeno per oftalmoscopio



018-442-010

Otoskopkopf mit Halogenbirne 2,5 V
 Otoscope head with halogen bulb 2,5 V
 Cabeza de otoscopio con bombilla de halógeno 2,5 V
 Testa di otoscopio con lampadina alogena 2,5 V



018-442-020

Ophthalmoskopkopf mit Halogenbirne 2,5 V
 Ophthalmoscope head with halogen bulb 2,5 V
 Cabeza de oftalmoscopio con bombilla de halógeno 2,5 V
 Testa di oftalmoscopio con lampadina alogena 2,5 V



018

Katheter-Einführungszangen
Catheter Introducing Forceps
Pinzas para introducir catéteres
Pinze introduttrici di cateteri



018-601-150



018-601-170



018-601-200



018-601-250

MAGILL

018-601-150	15,0 cm / 6"
018-601-170	17,0 cm / 6 ³ / ₄ "
018-601-200	20,0 cm / 8"
018-601-250	25,0cm / 9 ³ / ₄ "





019

Naht
Suture
Sutura
Sutura



019

Chirurgische Nadeln
Surgical Needles
Agujas quirúrgicas
Aghi chirurgici

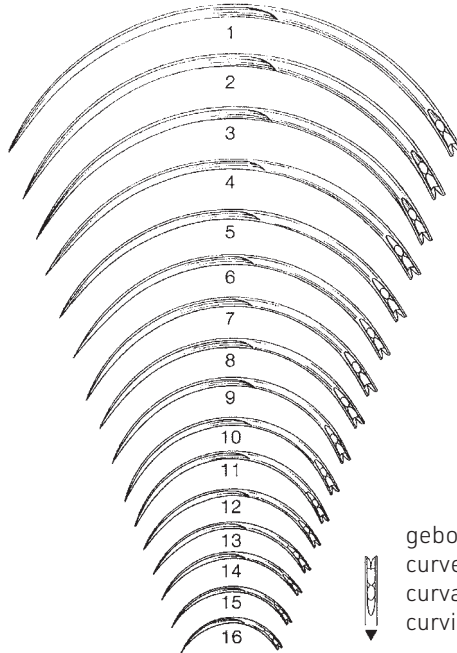

B

019-001-001	Fig. 1
019-001-002	Fig. 2
019-001-003	Fig. 3
019-001-004	Fig. 4
019-001-005	Fig. 5
019-001-006	Fig. 6
019-001-007	Fig. 7
019-001-008	Fig. 8
019-001-009	Fig. 9
019-001-010	Fig. 10
019-001-011	Fig. 11
019-001-012	Fig. 12
019-001-013	Fig. 13
019-001-014	Fig. 14
019-001-015	Fig. 15
019-001-016	Fig. 16

gebogen 3/8 Kreis
curved 3/8 circle
curvas 3/8 circulo
curvi 3/8 circolo

*in Packungen zu 12 Stück
*in packages of 12 pieces
*en paquets de 12 piezas
*in confezione da 12 pezzi

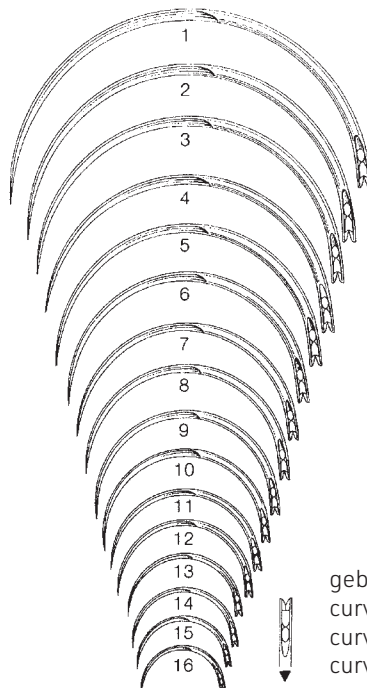

G

019-003-001	Fig. 1
019-003-002	Fig. 2
019-003-003	Fig. 3
019-003-004	Fig. 4
019-003-005	Fig. 5
019-003-006	Fig. 6
019-003-007	Fig. 7
019-003-008	Fig. 8
019-003-009	Fig. 9
019-003-010	Fig. 10
019-003-011	Fig. 11
019-003-012	Fig. 12
019-003-013	Fig. 13
019-003-014	Fig. 14
019-003-015	Fig. 15
019-003-016	Fig. 16

gebogen 1/2 Kreis
curved 1/2 circle
curvas 1/2 circulo
curvi 1/2 circolo

*in Packungen zu 12 Stück
*in packages of 12 pieces
*en paquets de 12 piezas
*in confezione da 12 pezzi

*Mindestbestellmenge 5 Dutzend
*Minimum order quantity 5 dozen
*Cantidad mínima de pedido 5 docenas
*Quantità di ordine minimo 5 dozzine

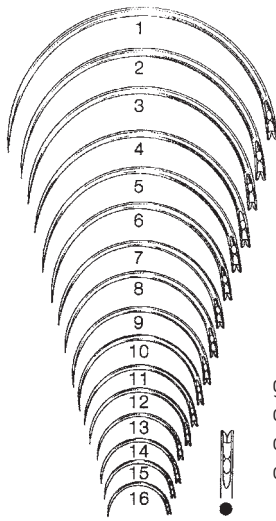

gebogen 1/2 Kreis
curved 1/2 circle
curvas 1/2 círculo
curvi 1/2 circolo

Gr

019-005-001	Fig. 1
019-005-002	Fig. 2
019-005-003	Fig. 3
019-005-004	Fig. 4
019-005-005	Fig. 5
019-005-006	Fig. 6
019-005-007	Fig. 7
019-005-008	Fig. 8
019-005-009	Fig. 9
019-005-010	Fig. 10
019-005-011	Fig. 11
019-005-012	Fig. 12
019-005-013	Fig. 13
019-005-014	Fig. 14
019-005-015	Fig. 15
019-005-016	Fig. 16

*in Packungen zu 12 Stück
*in packages of 12 pieces
*en paquetes de 12 piezas
*in confezione da 12 pezzi

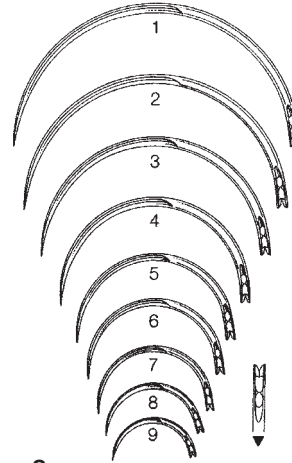

gebogen 1/2 Kreis
curved 1/2 circle
curvas 1/2 círculo
curvi 1/2 circolo

Ga

019-007-001	Fig. 1
019-007-002	Fig. 2
019-007-003	Fig. 3
019-007-004	Fig. 4
019-007-005	Fig. 5
019-007-006	Fig. 6
019-007-007	Fig. 7
019-007-008	Fig. 8
019-007-009	Fig. 9

*in Packungen zu 12 Stück
*in packages of 12 pieces
*en paquetes de 12 piezas
*in confezione da 12 pezzi

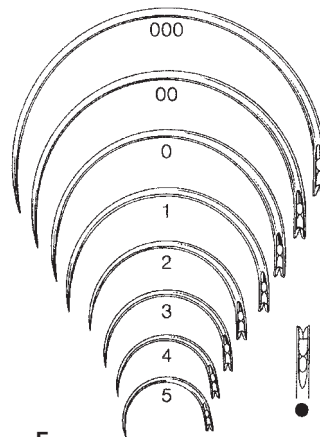

gebogen 1/2 Kreis
curved 1/2 circle
curvas 1/2 círculo
curvi 1/2 circolo

E

019-011-010	Fig. 0
019-011-020	Fig. 00
019-011-030	Fig. 000
019-013-001	Fig. 1
019-013-002	Fig. 2
019-013-003	Fig. 3
019-013-004	Fig. 4
019-013-005	Fig. 5

*in Packungen zu 12 Stück
*in packages of 12 pieces
*en paquetes de 12 piezas
*in confezione da 12 pezzi

*Mindestbestellmenge 5 Dutzend
*Minimum order quantity 5 dozen
*Cantidad mínima de pedido 5 docenas
*Quantità di ordine minimo 5 dozzine



019

Chirurgische Nadeln, Darmnadeln
 Surgical Needles, Intestinal Needles
 Agujas quirúrgicas, Agujas intestinales
 Aghi chirurgici, Aghi intestinali

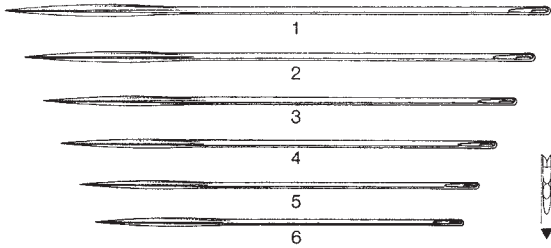

KEITH

- | | | |
|--------------------|--------|----------------------------|
| 019-016-001 | Fig. 1 | *in Packungen zu 12 Stück |
| 019-016-002 | Fig. 2 | *in packages of 12 pieces |
| 019-016-003 | Fig. 3 | *en paquets de 12 piezas |
| 019-016-004 | Fig. 4 | *in confezione da 12 pezzi |
| 019-016-005 | Fig. 5 | |
| 019-016-006 | Fig. 6 | |

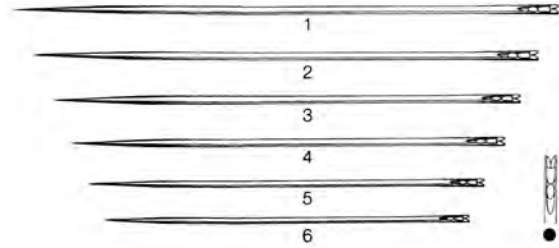

KEITH

- | | | |
|--------------------|--------|----------------------------|
| 019-018-001 | Fig. 1 | *in Packungen zu 12 Stück |
| 019-018-002 | Fig. 2 | *in packages of 12 pieces |
| 019-018-003 | Fig. 3 | *en paquets de 12 piezas |
| 019-018-004 | Fig. 4 | *in confezione da 12 pezzi |
| 019-018-005 | Fig. 5 | |
| 019-018-006 | Fig. 6 | |

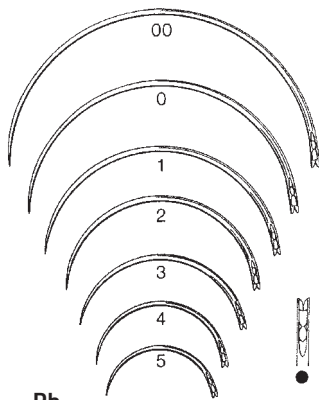

gebogen 1/2 Kreis
 curved 1/2 circle
 curvas 1/2 circulo
 curvi 1/2 circolo

Pb

- | | | |
|--------------------|---------|----------------------------|
| 019-021-010 | Fig. 0 | *in Packungen zu 12 Stück |
| 019-021-020 | Fig. 00 | *in packages of 12 pieces |
| 019-023-001 | Fig. 1 | *en paquets de 12 piezas |
| 019-023-002 | Fig. 2 | *in confezione da 12 pezzi |
| 019-023-003 | Fig. 3 | |
| 019-023-004 | Fig. 4 | |
| 019-023-005 | Fig. 5 | |

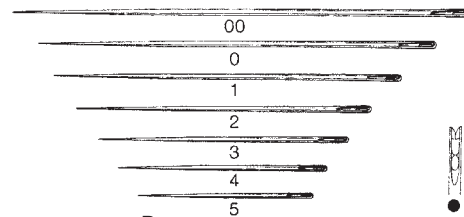

Pc

- | | | |
|--------------------|---------|----------------------------|
| 019-024-010 | Fig. 0 | *in Packungen zu 12 Stück |
| 019-024-020 | Fig. 00 | *in packages of 12 pieces |
| 019-026-001 | Fig. 1 | *en paquets de 12 piezas |
| 019-026-002 | Fig. 2 | *in confezione da 12 pezzi |
| 019-026-003 | Fig. 3 | |
| 019-026-004 | Fig. 4 | |
| 019-026-005 | Fig. 5 | |

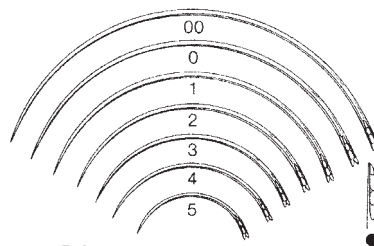

gebogen 3/8 Kreis
 curved 3/8 circle
 curvas 3/8 circulo
 curvi 3/8 circolo

Pd

- | | | |
|--------------------|---------|----------------------------|
| 019-027-010 | Fig. 0 | *in Packungen zu 12 Stück |
| 019-027-020 | Fig. 00 | *in packages of 12 pieces |
| 019-029-001 | Fig. 1 | *en paquets de 12 piezas |
| 019-029-002 | Fig. 2 | *in confezione da 12 pezzi |
| 019-029-003 | Fig. 3 | |
| 019-029-004 | Fig. 4 | |
| 019-029-005 | Fig. 5 | |

*Mindestbestellmenge 5 Dutzend
 *Minimum order quantity 5 dozen
 *Cantidad mínima de pedido 5 docenas
 *Quantità di ordine minimo 5 dozzine

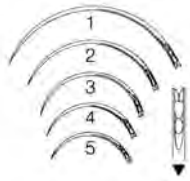

Ob

- 019-031-001** Fig. 1
- 019-031-002** Fig. 2
- 019-031-003** Fig. 3
- 019-031-004** Fig. 4
- 019-031-005** Fig. 5

gebogen 3/8 Kreis
 curved 3/8 circle
 curvas 3/8 círculo
 curvi 3/8 circolo

- *in Packungen zu 12 Stück
- *in packages of 12 pieces
- *en paquetes de 12 piezas
- *in confezione da 12 pezzi

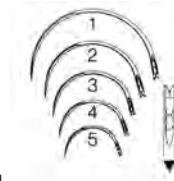

Og

- 019-033-001** Fig. 1
- 019-033-002** Fig. 2
- 019-033-003** Fig. 3
- 019-033-004** Fig. 4
- 019-033-005** Fig. 5

gebogen 1/2 Kreis
 curved 1/2 circle
 curvas 1/2 círculo
 curvi 1/2 circolo

- *in Packungen zu 12 Stück
- *in packages of 12 pieces
- *en paquetes de 12 piezas
- *in confezione da 12 pezzi

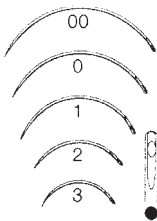

KALT

- 019-035-010** Fig. 0
- 019-035-020** Fig. 00
- 019-037-001** Fig. 1
- 019-037-002** Fig. 2
- 019-037-003** Fig. 3

gebogen 3/8 Kreis
 curved 3/8 circle
 curvas 3/8 círculo
 curvi 3/8 circolo

- *in Packungen zu 12 Stück
- *in packages of 12 pieces
- *en paquetes de 12 piezas
- *in confezione da 12 pezzi

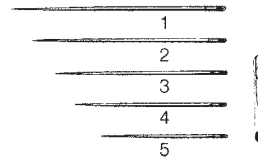

PAYR

- 019-040-001** Fig. 1
- 019-040-002** Fig. 2
- 019-040-003** Fig. 3
- 019-040-004** Fig. 4
- 019-040-005** Fig. 5

- *in Packungen zu 12 Stück
- *in packages of 12 pieces
- *en paquetes de 12 piezas
- *in confezione da 12 pezzi

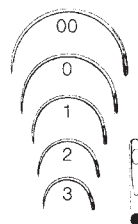

gebogen 1/2 Kreis
 curved 1/2 circle
 curvas 1/2 círculo
 curvi 1/2 circolo

PAYR

- 019-043-010** Fig. 0
- 019-043-020** Fig. 00
- 019-045-001** Fig. 1
- 019-045-002** Fig. 2
- 019-045-003** Fig. 3

- *in Packungen zu 12 Stück
- *in packages of 12 pieces
- *en paquetes de 12 piezas
- *in confezione da 12 pezzi

*Mindestbestellmenge 5 Dutzend
 *Minimum order quantity 5 dozen
 *Cantidad mínima de pedido 5 docenas
 *Quantità di ordine minimo 5 dozzine



019

Nadelkassetten
Needle Cases
Estuches para agujas
Scatole per aghi



019-070-001 150x95x13 mm



019-070-002 150x95x13 mm

perforierter Deckel und Boden
perforated lid and bottom
tapa y fondo perforado
coperchio e fondo perforati



019-070-003 150x95x13 mm

perforierter Boden
perforated bottom
fondo perforado
fondo perforato



019-070-005 150x95x13 mm



019-070-006 150x95x13 mm

perforierter Deckel und Boden
perforated lid and bottom
tapa y fondo perforado
coperchio e fondo perforati



019

Nadelkassetten
Needle Cases
Estuches para agujas
Scatole per aghi

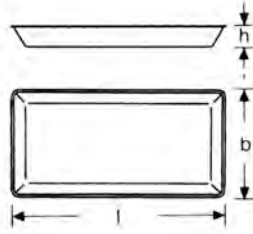

019-074-050 50x25x4,5 mm
019-074-065 65x42x8,0 mm
019-074-075 75x25x4,5 mm

019-076-050 50x25x4,5 mm
019-076-065 65x42x8,0 mm
019-076-075 75x25x4,5 mm



019-080-001 Ø 62x13 mm
Innendose allein, perforiert
Interior box, perforated
Caja interior, perforada
Scatola interiore, perforati

019-080-000 Ø 65x15 mm



KALT

019-100-140 14,0 cm / 5 1/2"



ARRUGA

019-104-140 - 019-105-140 14,0 cm / 5 1/2"



ARRUGA

019-106-160 - 019-107-160 16,0 cm / 6 1/4"



019-106-160



019-107-160



019

Mikro-Nadelhalter
Micro Needle Holders
Micro Porta-agujas
Micro Portaghi

Maul 0,5 mm
jaw 0,5 mm
boca 0,5 mm
muso 0,5 mm



019-108-100



019-109-100



ohne Sperre
without ratchet
sin cierre
senza chiusura

Maul 0,5 mm
jaw 0,5 mm
boca 0,5 mm
muso 0,5 mm



019-110-100



019-111-100



mit Sperre
with ratchet
con cierre
con chiusura

BARRAQUER-TROUTMAN

019-108-100 - 019-109-100 10,0 cm / 4"

BARRAQUER-TROUTMAN

019-110-100 - 019-111-100 10,0 cm / 4"

Maul 1,0 mm
jaw 1,0 mm
boca 1,0 mm
muso 1,0 mm

glatt
smooth
liso
liscio



019-112-115



019-112-130



019-112-140



019-113-115



019-113-130



019-113-140



ohne Sperre
without ratchet
sin cierre
senza chiusura

Maul 1,0 mm
jaw 1,0 mm
boca 1,0 mm
muso 1,0 mm

glatt
smooth
liso
liscio



019-114-115



019-114-130



019-114-140



019-115-115



019-115-130



019-115-140



mit Sperre
with ratchet
con cierre
con chiusura

BARRAQUER

019-112-115 - 019-113-115 11,5 cm / 4 1/2"
019-112-130 - 019-113-130 13,0 cm / 5 1/8"
019-112-140 - 019-113-140 14,0 cm / 5 1/2"

BARRAQUER

019-114-115 - 019-115-115 11,5 cm / 4 1/2"
019-114-130 - 019-115-130 13,0 cm / 5 1/8"
019-114-140 - 019-115-140 14,0 cm / 5 1/2"

Maul 1,0 mm
 jaw 1,0 mm
 boca 1,0 mm
 muso 1,0 mm



glatt
 smooth
 liso
 liscio

mit Sperre
 with ratchet
 con cierre
 con chiusura

Maul 1,0 mm
 jaw 1,0 mm
 boca 1,0 mm
 muso 1,0 mm



glatt
 smooth
 liso
 liscio

mit Sperre
 with ratchet
 con cierre
 con chiusura

BARRAQUER

019-120-150 15,0 cm / 6"
019-120-180 18,0 cm / 6"
019-120-210 21,0 cm / 8 1/4"

BARRAQUER

019-121-150 15,0 cm / 6"
019-121-180 18,0 cm / 6"
019-121-210 21,0 cm / 8 1/4"

Maul 1,0 mm
 jaw 1,0 mm
 boca 1,0 mm
 muso 1,0 mm



glatt
 smooth
 liso
 liscio

ohne Sperre
 without ratchet
 sin cierre
 senza chiusura

Maul 1,0 mm
 jaw 1,0 mm
 boca 1,0 mm
 muso 1,0 mm



glatt
 smooth
 liso
 liscio

ohne Sperre
 without ratchet
 sin cierre
 senza chiusura

gebogen
 curved
 curva
 curva

ohne Sperre
 without ratchet
 sin cierre
 senza chiusura

BARRAQUER

019-124-150 15,0 cm / 6"
019-124-180 18,0 cm / 6"

BARRAQUER

019-125-150 15,0 cm / 6"
019-125-180 18,0 cm / 6"

GOMEL

019-127-140 14,0 cm / 5 1/2"



019

Mikro-Nadelhalter
Micro Needle Holders
Micro Porta-agujas
Micro Portaghi



019-130-140



019-131-140

mit Sperre
with ratchet
con cierre
con chiusura



019-132-140



019-133-140

ohne Sperre
without ratchet
sin cierre
senza chiusura

CASTROVIEJO

019-130-140 - 019-131-140 14,0 cm / 5 1/2"

CASTROVIEJO

019-132-140 - 019-133-140 14,0 cm / 5 1/2"



019-136-140



019-137-140

mit Sperre
with ratchet
con cierre
con chiusura



019-138-140



019-139-140

ohne Sperre
without ratchet
sin cierre
senza chiusura

CASTROVIEJO

019-136-140 - 019-137-140 14,0 cm / 5 1/2"

CASTROVIEJO

019-138-140 - 019-139-140 14,0 cm / 5 1/2"



mit Sperre
 with ratchet
 con cierre
 con chiusura

CASTROVIEJO (JACOBSON)

019-144-180 18,0 cm / 7"
019-144-210 21,0 cm / 8¹/₄"



mit Sperre
 with ratchet
 con cierre
 con chiusura

CASTROVIEJO (JACOBSON)

019-145-180 18,0 cm / 7"
019-145-210 21,0 cm / 8¹/₄"



mit Sperre
 with ratchet
 con cierre
 con chiusura

CASTROVIEJO (JACOBSON)

019-146-180 18,0 cm / 7"
019-146-210 21,0 cm / 7"



mit Sperre
 with ratchet
 con cierre
 con chiusura

CASTROVIEJO (JACOBSON)

019-147-180 18,0 cm / 7"
019-147-210 21,0 cm / 7"



ohne Sperre
 without ratchet
 sin cierre
 senza chiusura

CASTROVIEJO (JACOBSON)

019-148-180 18,0 cm / 7"
019-148-210 21,0 cm / 7"



ohne Sperre
 without ratchet
 sin cierre
 senza chiusura

CASTROVIEJO (JACOBSON)

019-149-180 18,0 cm / 7"
019-149-210 21,0 cm / 7"



ohne Sperre
 without ratchet
 sin cierre
 senza chiusura

CASTROVIEJO (JACOBSON)

019-150-180 18,0 cm / 7"
019-150-210 21,0 cm / 7"



ohne Sperre
 without ratchet
 sin cierre
 senza chiusura

CASTROVIEJO (JACOBSON)

019-151-180 18,0 cm / 7"
019-151-210 21,0 cm / 7"



019

Mikro-Nadelhalter
 Micro Needle Holders
 Micro Porta-agujas
 Micro Portaghi



 glatt
 smooth
 liso
 liscio

ohne Sperre
 without ratchet
 sin cierre
 senza chiusura

YASARGIL

019-170-200 20,0 cm / 8"
019-170-225 22,5 cm / 9"
019-170-245 24,5 cm / 9²/₃"



 glatt
 smooth
 liso
 liscio

ohne Sperre
 without ratchet
 sin cierre
 senza chiusura

YASARGIL

019-171-200 20,0 cm / 8"
019-171-225 22,5 cm / 9"
019-171-245 24,5 cm / 9²/₃"



 glatt
 smooth
 liso
 liscio

CASTROVIEJO

019-186-130 13,0 cm / 5¹/₈"



 glatt
 smooth
 liso
 liscio

CASTROVIEJO

019-187-130 13,0 cm / 5¹/₈"



DERF

019-200-125 13,0 cm / 5¹/₈"



DERF

019-202-125 12,5 cm / 5"



COLLIER

019-204-125 12,5 cm / 5"

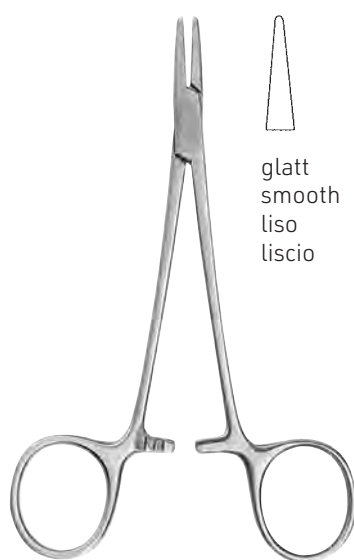

glatt
smooth
liso
liscio

WEBSTER

019-210-130 13,0 cm / 5"



gerieft
serrated
estriado
striato

WEBSTER

019-212-130 13,0 cm / 5"



glatt
smooth
liso
liscio

HALSEY

019-216-115 11,5 cm / 4"
019-216-130 13,0 cm / 5¹/₈"



019

Nadelhalter
Needle Holders
Porta-agujas
Portaghi



HALSEY

019-218-130 13,0 cm / 5¹/₈"



glattes Maul mit Spezialkehlung
smooth jaw, special groove
boca lisa, especialmente acanalada
mors lisse, avec stries spéciales
morso liscio con scannellatura speciale

NEIVERT

019-220-130 13,0 cm / 5¹/₈"



BAUMGARTNER

019-224-140 14,0 cm / 5¹/₂"

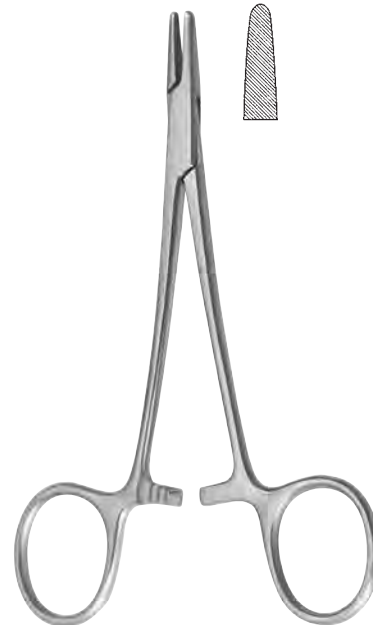

BROWN

019-226-130 13,0 cm / 5¹/₈"
019-226-180 18,0 cm / 7"



CRILE MURRAY

019-228-150 15,0 cm / 6"



CRILE WOOD

019-230-150 15,0 cm / 6"
019-230-180 18,0 cm / 7"
019-230-200 20,0 cm / 8"



ADSON

019-232-180 18,0 cm / 7"



METZENBAUM

019-234-180 18,0 cm / 7"



MASS.-GENERAL-HOSPITAL

019-236-170 17,0 cm / 6³/₄"



019

Nadelhalter
Needle Holders
Porta-agujas
Portaghi

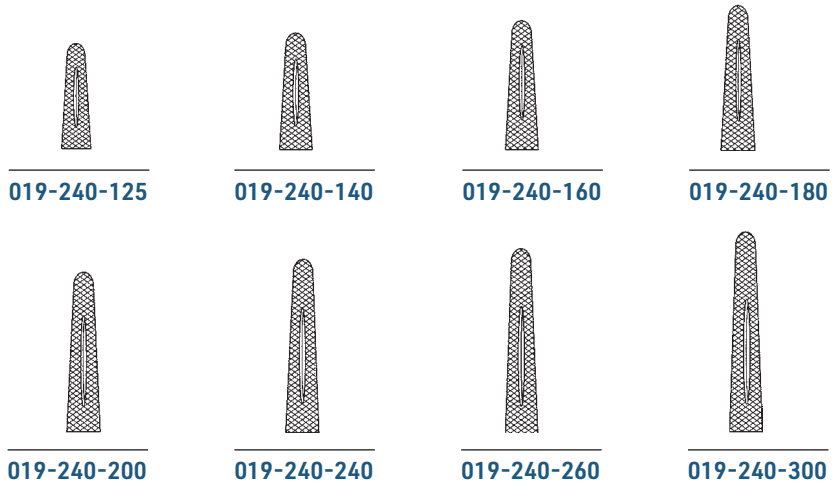

MAYO-HEGAR

019-240-125	12,5 cm / 5"
019-240-140	14,0 cm / 5 1/2"
019-240-160	16,0 cm / 6 1/4"
019-240-180	18,0 cm / 7"
019-240-200	20,0 cm / 8"
019-240-240	24,0 cm / 9 1/2"
019-240-260	26,0 cm / 10 1/4"
019-240-300	30,0 cm / 11 3/4"



schlankes Modell
delicate pattern
modelo delgado
modello gracile

MAYO HEGAR

019-242-160	16,0 cm / 6 1/4"
019-242-180	18,0 cm / 7"
019-242-200	20,0 cm / 8"



HEANEY

019-245-210 21,0 cm / 8¹/₄"



JAMISON

019-248-235 23,5 cm / 9¹/₄"



MASSON

019-250-270 27,0 cm / 10¹/₂"



019

Nadelhalter
Needle Holders
Porta-agujas
Portaghi



FINOCHIETTO

019-253-270 27,0 cm / 10¹/₂"



WANGENSTEEN

019-256-270 27,0 cm / 10¹/₂"



JOHNSON

019-257-270 27,0 cm / 10¹/₂"

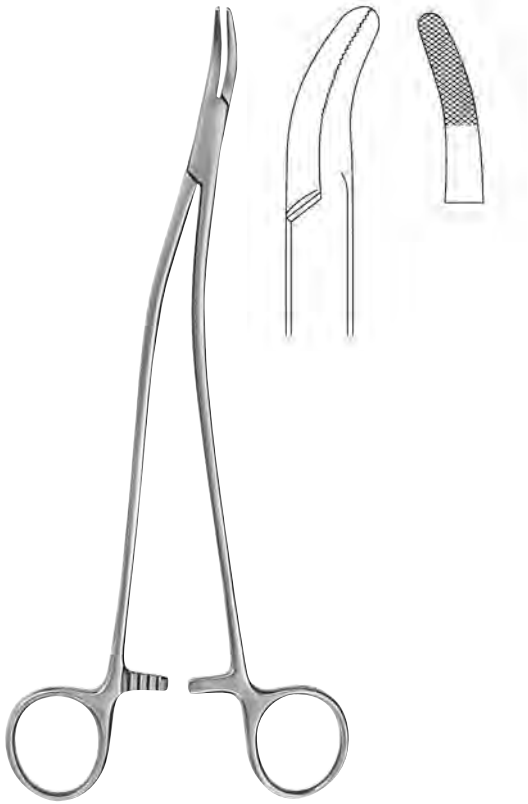

STRATTE

019-259-230 23,0 cm / 9"



MAYO-HEGAR

019-260-165 16,5 cm / 6 1/2"
019-260-190 19,0 cm / 7 1/2"



HEGAR

019-262-150 15,0 cm / 6"
019-262-175 17,5 cm / 7"
019-262-205 20,5 cm / 8"

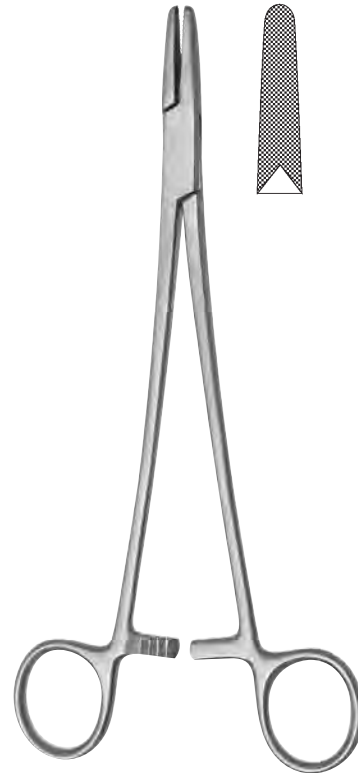

HEGAR

019-264-205 20,5 cm / 8"



019

Nadelhalter
Needle Holders
Porta-agujas
Portaghi



OLSEN-HEGAR

019-270-115 11,5 cm / 4½"
019-270-140 14,0 cm / 5½"



OLSEN-HEGAR

019-272-185 18,5 cm / 7¼"

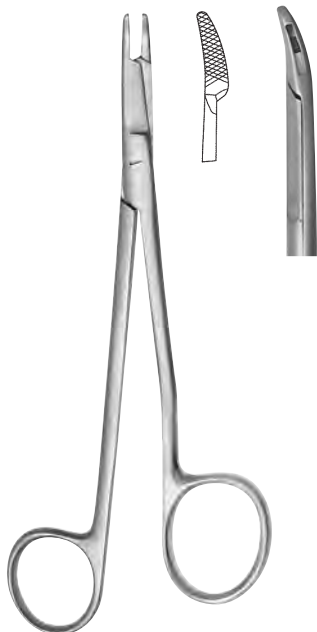

BABY-GILLIES

019-274-150 15,0 cm / 6"

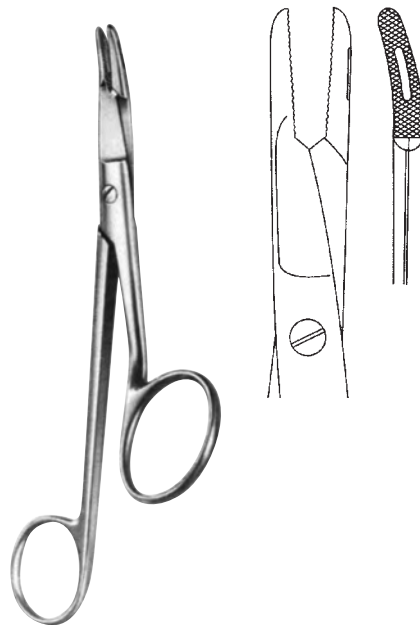

GILLIES

019-276-160 16,0 cm / 6¼"

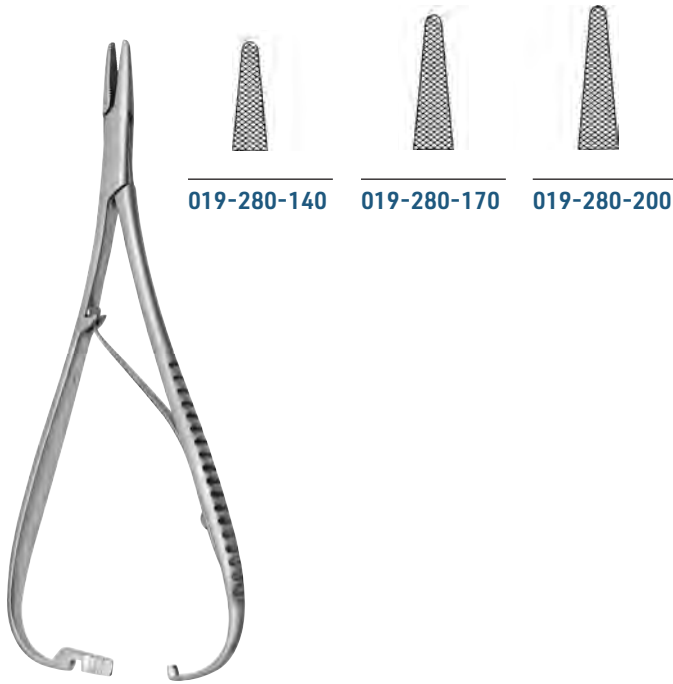

019-280-140

019-280-170

019-280-200

MATHIEU

- 019-280-140 14,0 cm / 5½"
- 019-280-170 17,0 cm / 6¾"
- 019-280-200 20,0 cm / 8"

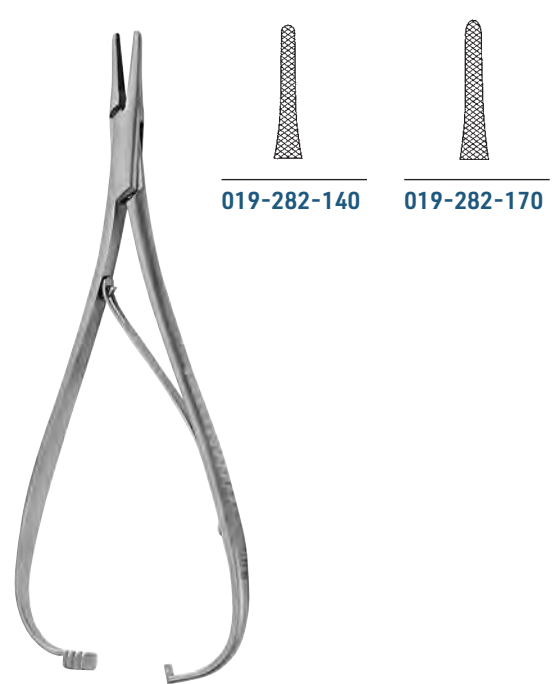

019-282-140

019-282-170

MATHIEU-KOCHER

- 019-282-140 14,0 cm / 5½"
- 019-282-170 17,0 cm / 6¾"

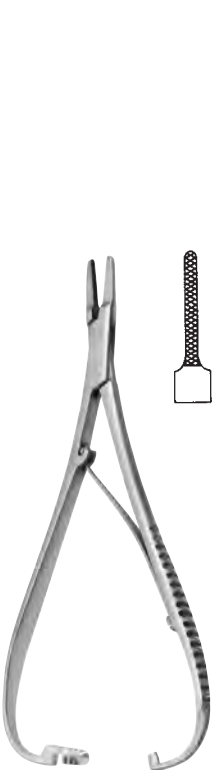

MATHIEU-RYDER

- 019-286-140 14,0 cm / 5½"



TOENNIS

- 019-290-180 18,0 cm / 7"



LICHTENBERG

- 019-292-200 20,0 cm / 8"



019

Nadelhalter mit Hartmetalleinlagen
Needle Holders with tungsten carbide inserts
Porta-agujas con bocas de carburo tungsteno
Portaghi con morsi in carburo di tungsteno

Hartmetalleinlagen mit präzise gearbeitetem Pyramidenprofil garantieren einen sicheren Halt der Nadel.

Tungsten carbide inserts with precisely worked out structure guarantee to grip the needle securely.

Capas intermedias de carburo tungsteno con perfil amoldado piramidal que garantiza un sujeto seguro de la aguja.

Inserti in carburo di tungsteno che garantiscono una perfetta tenuta dell'ago.

Gebrochene Kanten verhindern ein Verfangen des Nahtmaterials.

Bevelled edges to prevent catching of suture material.

Bordes quebrados evitan que se enrede el material de sutura.

I bordi squadri evitano che si impigliano i fili di sutura.

Vergoldete Ringe als leichte Kennzeichnung.

Gold-plated rings for easy identification.

Anillos dorados para fácil identificación

Anelli dorata permette una facile identificazione.

Leichtgängige Sperre ermöglicht eine sichere Arbeitsweise.

Soft working catch provides safe handling.

El cierre suave facilita un manejo seguro.

Il bloccaggio leggero e preciso facilita un uso sicuro.

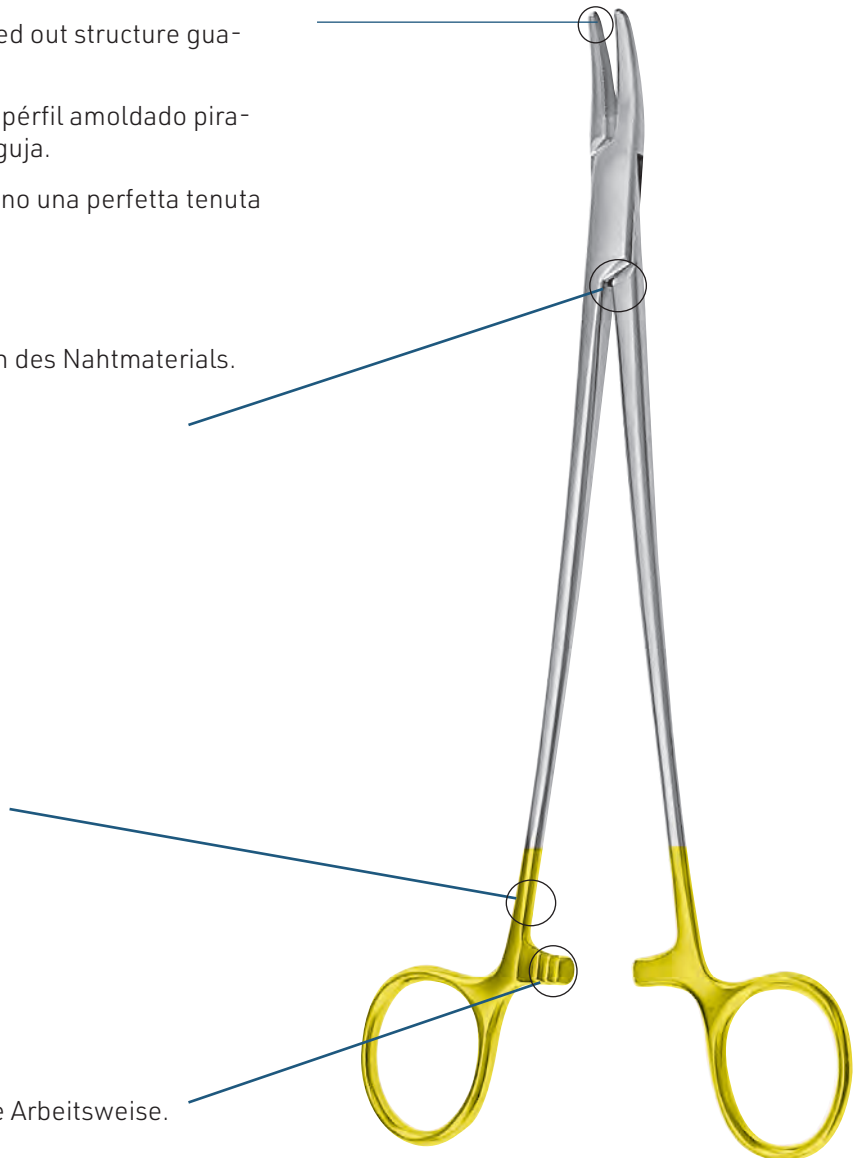

Je nach Anwendungsgebiet stehen für TC Nadelhalter unterschiedliche Hartmetalleinlagen zur Verfügung:
According to the field of application, there are various types of tungsten carbide inserts for TC needle holders:
Según campo de aplicación, disponemos de TC porta-agujas con varias capas intermedias:
A seconda delle necessità disponiamo di TC portaghi con varie capacità intermedie:

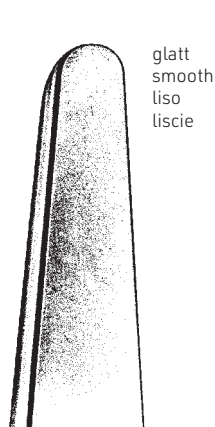

Zum Halten von extrem feinem Nahtmaterial.
For holding the smallest suture sizes.
Para sujetar suturas muy finas.
Per lavorare con suture sottilissime

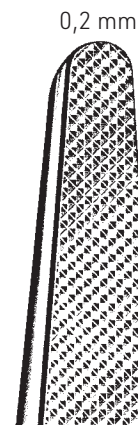

Zum Halten von Nahtmaterial der Stärken 7/0 bis 10/0.
For holding the suture sizes from 7/0 to 10/0.
Para sujetar suturas de gruesas 7/0 hasta 10/0.
Per lavorare con suture da 7/0 a 10/0.

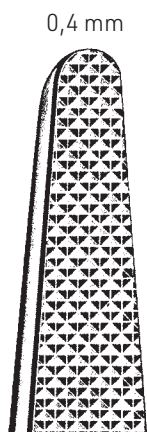

Zum Halten von Nahtmaterial der Stärken 4/0 bis 6/0.
For holding the suture sizes from 4/0 to 6/0.
Para sujetar suturas de gruesas 4/0 hasta 6/0.
Per lavorare con suture da 4/0 a 6/0.

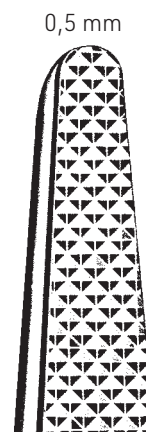

Zum Halten von Nahtmaterial der Stärke 3/0 und kräftiger.
For holding the suture size 3/0 and larger.
Para sujetar suturas de 3/0 y más gruesas.
Per lavorare con suture da 3/0 in poi.



019

Nadelhalter mit Hartmetalleinlagen
Needle Holders with tungsten carbide inserts
Porta-agujas con bocas de carburo tungsteno
Portaghi con morsi in carburo di tungsteno



KALT

019-300-140 14,0 cm / 5¹/₂"



019-304-160



019-305-160

ARRUGA

019-304-160 - 019-305-160 16,0 cm / 6¹/₄"



BOYTON

019-310-120 12,0 cm / 4³/₄"



ohne Sperre
 without ratchet
 sin cierre
 senza chiusura

CASTROVIEJO (JACOBSON)

- 019-320-140** 14,0 cm / 5 1/2"
- 019-320-180** 18,0 cm / 7"
- 019-320-220** 22,0 cm / 8 3/4"



ohne Sperre
 without ratchet
 sin cierre
 senza chiusura

CASTROVIEJO (JACOBSON)

- 019-321-140** 14,0 cm / 5 1/2"
- 019-321-180** 18,0 cm / 7"
- 019-321-220** 22,0 cm / 8 3/4"



ohne Sperre
 without ratchet
 sin cierre
 senza chiusura

CASTROVIEJO (JACOBSON)

- 019-330-140** 14,0 cm / 5 1/2"
- 019-330-180** 18,0 cm / 7"
- 019-330-220** 22,0 cm / 8 3/4"



ohne Sperre
 without ratchet
 sin cierre
 senza chiusura

CASTROVIEJO (JACOBSON)

- 019-331-140** 14,0 cm / 5 1/2"
- 019-331-180** 18,0 cm / 7"
- 019-331-220** 22,0 cm / 8 3/4"



mit Sperre
 with ratchet
 con cierre
 con chiusura

CASTROVIEJO (JACOBSON)

- 019-340-140** 14,0 cm / 5 1/2"
- 019-340-180** 18,0 cm / 7"
- 019-340-220** 22,0 cm / 8 3/4"



mit Sperre
 with ratchet
 con cierre
 con chiusura

CASTROVIEJO (JACOBSON)

- 019-341-140** 14,0 cm / 5 1/2"
- 019-341-180** 18,0 cm / 7"
- 019-341-220** 22,0 cm / 8 3/4"



019

Nadelhalter mit Hartmetalleinlagen
Needle Holders with tungsten carbide inserts
Porta-agujas con bocas de carburo tungsteno
Portaghi con morsi in carburo di tungsteno



CASTROVIEJO (JACOBSON)

019-350-140 14,0 cm / 5 1/2"
019-350-180 18,0 cm / 7"
019-350-220 22,0 cm / 8 3/4"



CASTROVIEJO (JACOBSON)

019-351-140 14,0 cm / 5 1/2"
019-351-180 18,0 cm / 7"
019-351-220 22,0 cm / 8 3/4"



019-360-180



019-361-180



BARRAQUER

019-370-180 18,0 cm / 7"



BARRAQUER

019-371-140 14,0 cm / 5 1/2"
019-371-180 18,0 cm / 7"

BARRAQUER

019-360-180 - 019-361-180 18,0 cm / 7"



BARRAQUER

019-380-180 18,0 cm / 7"
019-380-210 21,0 cm / 8¹/₄"



BARRAQUER

019-381-180 18,0 cm / 7"
019-381-210 21,0 cm / 8¹/₄"



BARRAQUER

019-390-180 18,0 cm / 7"
019-390-210 21,0 cm / 8¹/₄"



BARRAQUER

019-391-140 14,0 cm / 5¹/₂"
019-391-180 18,0 cm / 7"
019-391-210 21,0 cm / 8¹/₄"



diamantbeschichtet
 diamond coated
 capa de diamante
 strato di diamante

YASARGIL

019-400-225 22,5 cm / 9"



diamantbeschichtet
 diamond coated
 capa de diamante
 strato di diamante

YASARGIL

019-401-225 22,5 cm / 9"

ohne Sperre
 without ratchet
 sub cierre
 senza chiusura



019

Nadelhalter mit Hartmetalleinlagen
Needle Holders with tungsten carbide inserts
Porta-agujas con bocas de carburo tungsteno
Portaghi con morsi in carburo di tungsteno



DIETHRICH

- 019-410-160** 16,0 cm / 6¹/₄"
- 019-410-180** 18,0 cm / 7"
- 019-410-200** 20,0 cm / 8"
- 019-410-230** 23,0 cm / 9"
- 019-410-250** 25,0 cm / 9³/₄"



DIETHRICH

- 019-420-160** 16,0 cm / 6¹/₄"
- 019-420-180** 18,0 cm / 7"
- 019-420-200** 20,0 cm / 8"
- 019-420-230** 23,0 cm / 9"
- 019-420-250** 25,0 cm / 9³/₄"

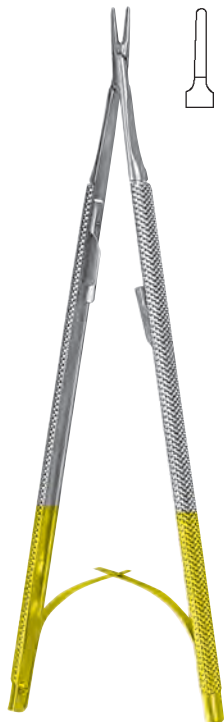

HEPP-SCHEIDEL

- 019-430-180** 18,0 cm / 7"



DERF

- 019-500-120** 12,0 cm / 4³/₄"

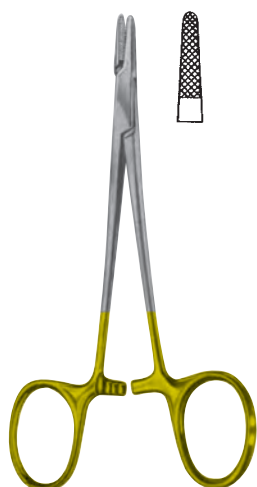

CONVERSE

019-504-120 12,0 cm / 4³/₄"

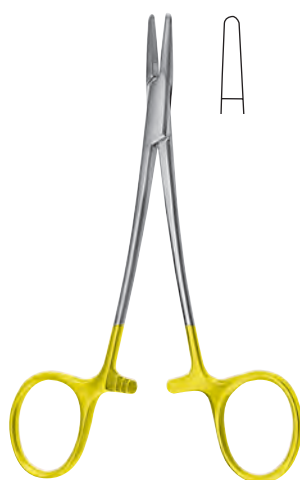

WEBSTER

019-510-115 11,5 cm / 4¹/₂"
019-510-130 13,0 cm / 5¹/₈"



WEBSTER

019-511-130 13,0 cm / 5¹/₈"



HALSEY

019-520-130 13,0 cm / 5¹/₈"



HALSEY

019-522-115 11,5 cm / 4¹/₂"
019-522-130 13,0 cm / 5¹/₈"



NEIVERT

019-530-130 13,0 cm / 5¹/₈"



019

Nadelhalter mit Hartmetalleinlagen
Needle Holders with tungsten carbide inserts
Porta-agujas con bocas de carburo tungsteno
Portaghi con morsi in carburo di tungsteno

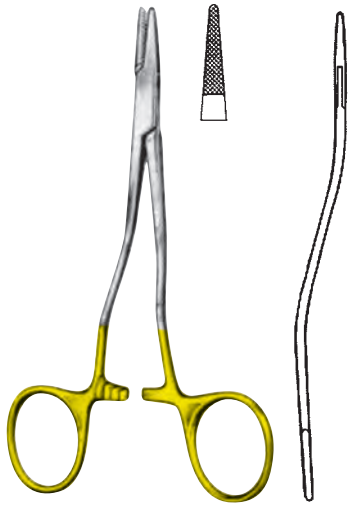

KILNER
019-535-135 13,5 cm / 5¹/₄"



BAUMGARTNER
019-540-125 12,5 cm / 5"
019-540-140 14,0 cm / 5¹/₂"



019-550-140



019-550-160



019-550-180



019-550-200



019-550-240



019-550-260



019-550-300



MAYO-HEGAR
019-550-140 14,0 cm / 5¹/₂"
019-550-160 16,0 cm / 6¹/₄"
019-550-180 18,0 cm / 7"
019-550-200 20,0 cm / 8"
019-550-240 24,0 cm / 9¹/₂"
019-550-260 26,0 cm / 10¹/₄"
019-550-300 30,0 cm / 11³/₄"

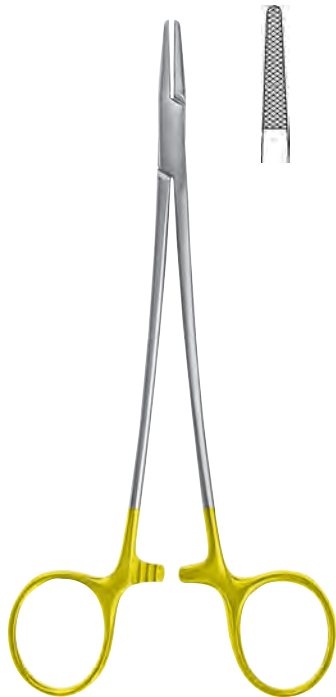

MAYO-HEGAR - SLENDER PATTERN

019-552-180 18,0 cm / 7"
019-552-200 20,0 cm / 8"

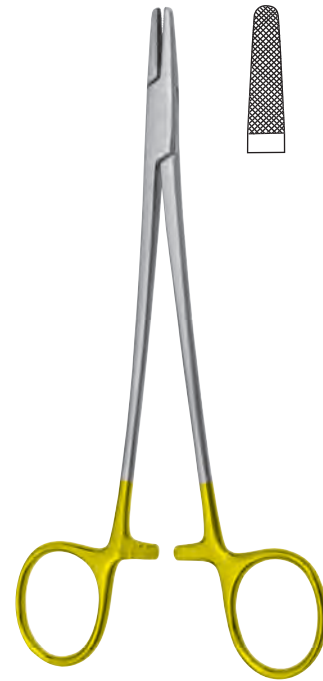

MAYO-HEGAR - HEAVY PATTERN

019-554-180 18,0 cm / 7"



HEGAR

019-556-200 20,0 cm / 8"
019-556-240 24,0 cm / 9⁵/₈"

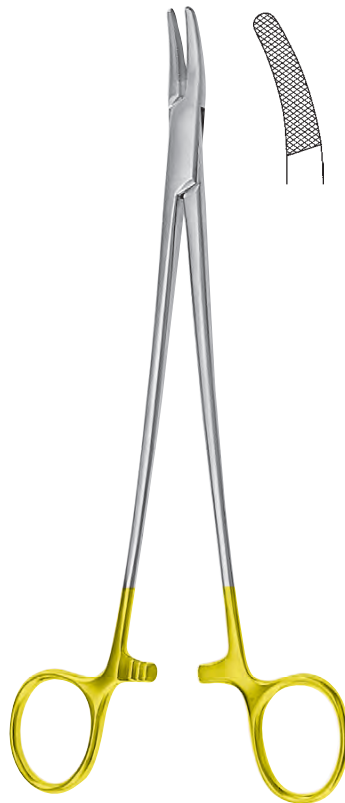

MAYO-HEGAR (HEANEY)

019-557-200 20,0 cm / 8"
019-557-240 24,0 cm / 9⁵/₈"
019-557-260 26,0 cm / 10¹/₄"

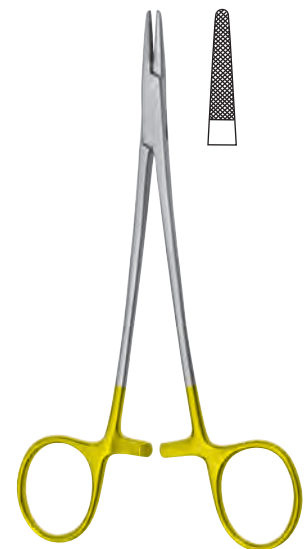

CRILE-WOOD BABY

019-560-150 15,0 cm / 6"



019

Nadelhalter mit Hartmetalleinlagen
Needle Holders with tungsten carbide inserts
Porta-agujas con bocas de carburo tungsteno
Portaghi con morsi in carburo di tungsteno

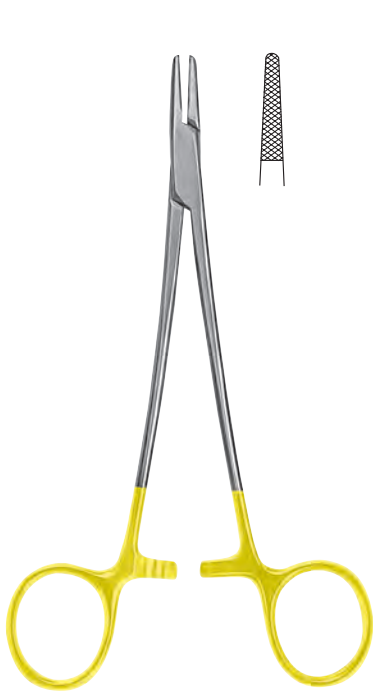

CRILE-WOOD

- 019-570-150** 15,0 cm / 6"
- 019-570-180** 18,0 cm / 7"
- 019-570-200** 20,0 cm / 8"
- 019-570-230** 23,0 cm / 9"
- 019-570-260** 26,0 cm / 10¹/₄"

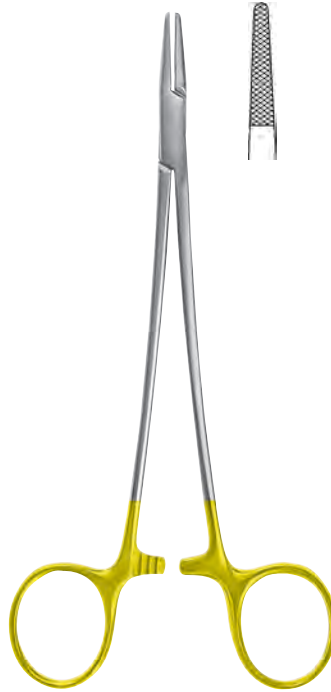

DEBAKEY

- 019-580-150** 15,0 cm / 6"
- 019-580-165** 16,5 cm / 6¹/₂"
- 019-580-180** 18,0 cm / 7"
- 019-580-200** 20,0 cm / 8"
- 019-580-230** 23,0 cm / 9"
- 019-580-260** 26,0 cm / 10¹/₄"
- 019-580-310** 31,0 cm / 12¹/₄"



MIKRO-SLIM

- 019-586-150** 15,0 cm / 6"
- 019-586-180** 18,0 cm / 7"
- 019-586-200** 20,0 cm / 8"
- 019-586-230** 23,0 cm / 9"

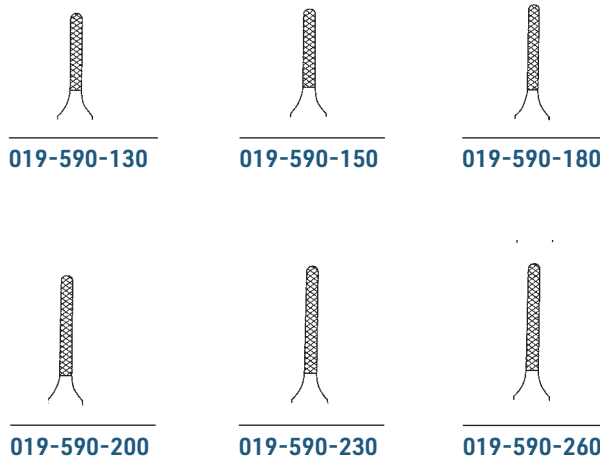
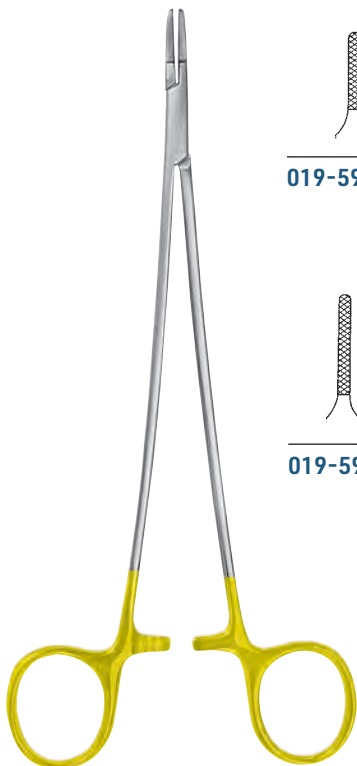

RYDER-FRENCH EYE

- 019-590-130** 13,0 cm / 5¹/₈"
- 019-590-150** 15,0 cm / 6"
- 019-590-180** 18,0 cm / 7"
- 019-590-200** 20,0 cm / 8"
- 019-590-230** 23,0 cm / 9"
- 019-590-260** 26,0 cm / 10¹/₄"

Nadelhalter mit Hartmetalleinlagen
 Needle Holders with tungsten carbide inserts
 Porta-agujas con bocas de carburo tungsteno
 Portaghi con morsi in carburo di tungsteno



019

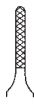

019-600-130



019-600-150



019-600-180

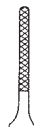

019-600-200



019-600-230



019-600-260

RYDER-MINI	
019-600-130	13,0 cm / 5 ¹ / ₈ "
019-600-150	15,0 cm / 6"
019-600-180	18,0 cm / 7"
019-600-200	20,0 cm / 8"
019-600-230	23,0 cm / 9"
019-600-260	26,0 cm / 10 ¹ / ₄ "



019-610-140



019-610-180



019-610-200



019-610-230

HEGAR-VASCULAR	
019-610-140	14,0 cm / 5 ¹ / ₂ "
019-610-180	18,0 cm / 7"
019-610-200	20,0 cm / 8"
019-610-230	23,0 cm / 9"



019

Nadelhalter mit Hartmetalleinlagen
 Needle Holders with tungsten carbide inserts
 Porta-agujas con bocas de carburo tungsteno
 Portaghi con morsi in carburo di tungsteno

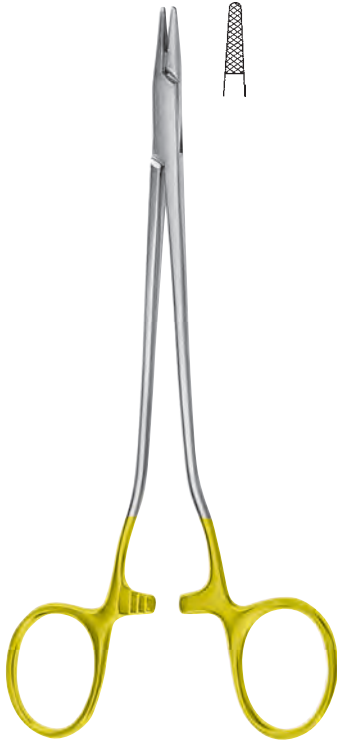

SENNING

- 019-620-150** 15,0 cm / 6"
- 019-620-170** 17,0 cm / 6³/₄"
- 019-620-200** 20,0 cm / 8"

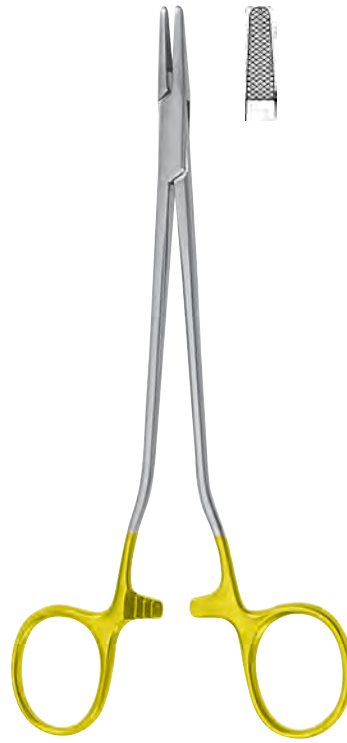

SAROT

- 019-630-180** 18,0 cm / 7"
- 019-630-200** 20,0 cm / 8"
- 019-630-230** 23,0 cm / 9"
- 019-630-260** 26,0 cm / 10¹/₄"

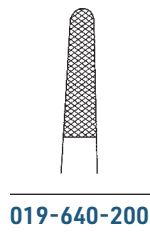
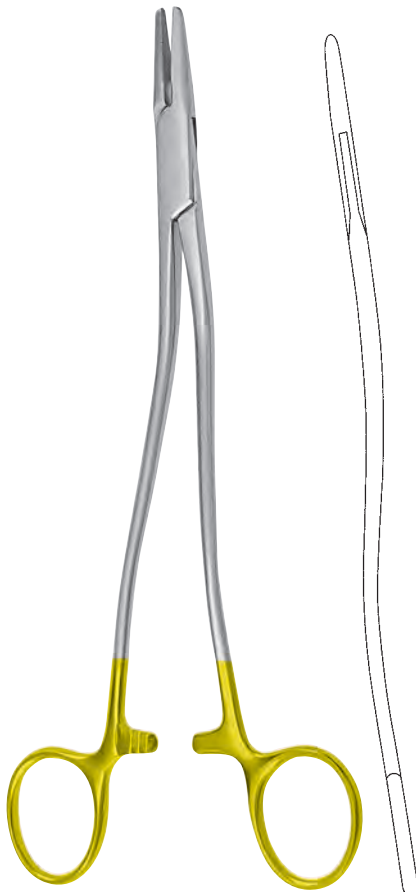

019-640-200

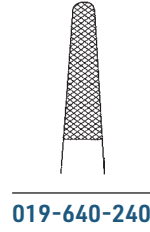

019-640-240

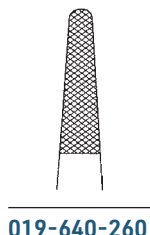

019-640-260

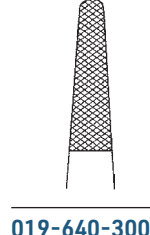

019-640-300

BOZEMANN

- 019-640-200** 20,0 cm / 8"
- 019-640-240** 24,0 cm / 9¹/₂"
- 019-640-260** 26,0 cm / 10¹/₄"
- 019-640-300** 30,0 cm / 11³/₄"

Nadelhalter mit Hartmetalleinlagen
 Needle Holders with tungsten carbide inserts
 Porta-agujas con bocas de carburo tungsteno
 Portaghi con morsi in carburo di tungsteno



019

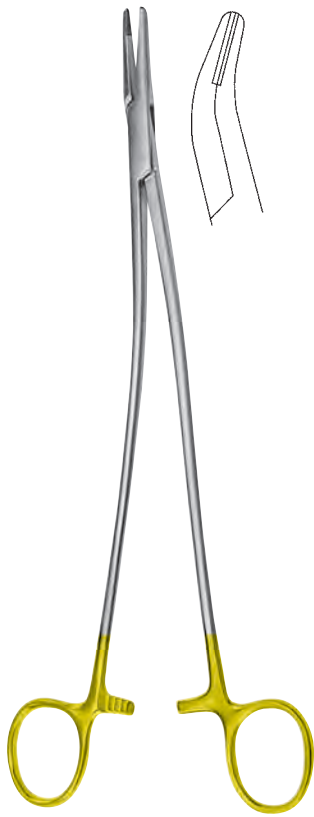

019-644-210



019-644-230



STRATTE

019-644-210 21,0 cm / 8¹/₄"
 019-644-230 23,0 cm / 9"



MASSON

019-650-270 27,0 cm / 10¹/₄"

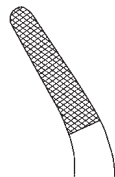

FINOCHIETTO

019-651-270 27,0 cm / 10¹/₄"

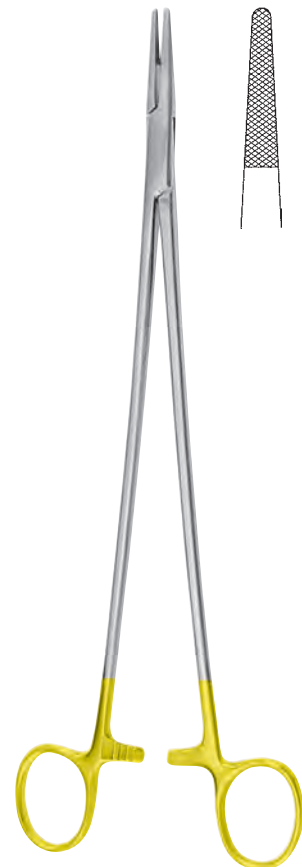

WANGENSTEEN

019-654-270 28,0 cm / 11"



019

Nadelhalter mit Hartmetalleinlagen
Needle Holders with tungsten carbide inserts
Porta-agujas con bocas de carburo tungsteno
Portaghi con morsi in carburo di tungsteno

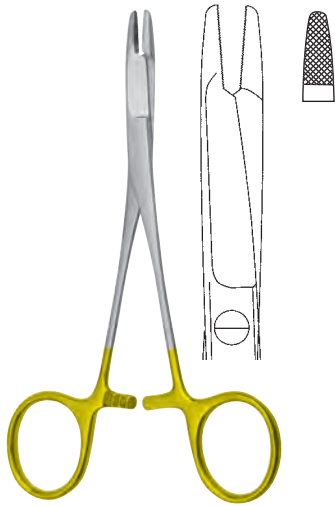

OLSEN-HEGAR

- 019-660-115 11,5 cm / 4 1/2"
- 019-660-140 14,0 cm / 5 1/2"
- 019-660-170 17,0 cm / 6 3/4"
- 019-660-185 18,5 cm / 7 1/4"

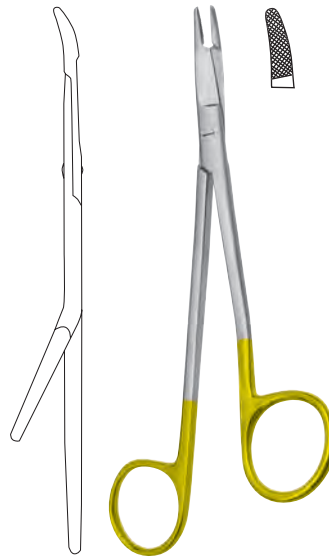

BABY-GILLIES

- 019-662-150 15,0 cm / 6"



GILLIES

- 019-664-160 16,0 cm / 6 1/4"

Nadelhalter mit Hartmetalleinlagen
 Needle Holders with tungsten carbide inserts
 Porta-agujas con bocas de carburo tungsteno
 Portaghi con morsi in carburo di tungsteno



019



019-670-140



019-670-170



019-670-200



019-670-240

MATHIEU

- 019-670-140 14,0 cm / 5 1/2"
- 019-670-170 17,0 cm / 6 3/4"
- 019-670-200 20,0 cm / 8"
- 019-670-240 24,0 cm / 6 1/2"



019-672-140



019-672-170



019-672-200

MATHIEU-KOCHER

- 019-672-140 14,0 cm / 5 1/2"
- 019-672-170 17,0 cm / 6 3/4"
- 019-672-200 20,0 cm / 8"



019

Nadelhalter mit Hartmetalleinlagen
 Needle Holders with tungsten carbide inserts
 Porta-agujas con bocas de carburo tungsteno
 Portaghi con morsi in carburo di tungsteno



019-674-140



019-674-170



019-674-200



019-680-140



019-680-170



019-680-200

MATHIEU-RYDER

- 019-674-140 14,0 cm / 5 1/2"
- 019-674-170 17,0 cm / 6 3/4"
- 019-674-200 20,0 cm / 8"

MATHIEU

- 019-680-140 14,0 cm / 5 1/2"
- 019-680-170 17,0 cm / 6 3/4"
- 019-680-200 20,0 cm / 8"



019-690-160



019-690-180



019-690-200

LANGENBECK

- 019-690-160 16,0 cm / 6 1/4"
- 019-690-180 18,0 cm / 7"
- 019-690-200 20,0 cm / 8"



CRILE
019-696-150 15,0 cm / 6"



TOENNIS
019-696-180 18,0 cm / 7"



LICHTENBERG
019-700-170 17,0 cm / 6³/₄"
019-700-200 20,0 cm / 8"



LICHTENBERG
019-701-170 17,0 cm / 6³/₄"



mit langem Hals
 with long neck
 con cuello largo
 con collo lungo

HÖSEL
019-710-200 20,0 cm / 8"



019

Nadelhalter mit Hartmetalleinlagen
Needle Holders with tungsten carbide inserts
Porta-agujas con bocas de carburo tungsteno
Portaghi con morsi in carburo di tungsteno



019-714-200



019-714-230



mit langem Hals
with long neck
con cuello largo
con collo lungo

ZWEIFEL

019-714-200 20,0 cm / 8"
019-714-230 23,0 cm / 9"

HÖSEL

019-720-260 26,0 cm / 10³/₄"

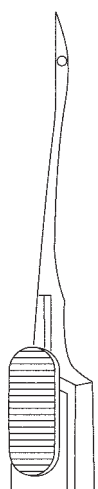

019-750-001



019-750-002



019-750-003



019-750-004

REVERDIN

019-750-001 - 019-750-004 14,0 cm / 5 1/2"

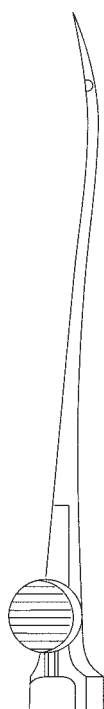

019-752-001
019-754-001

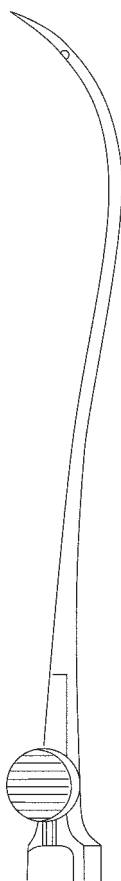

019-752-002
019-754-002

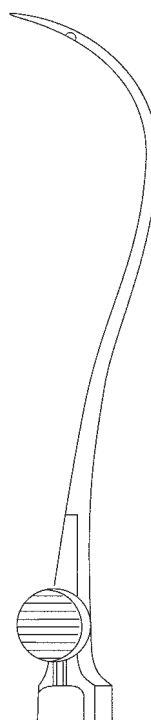

019-752-003
019-754-003

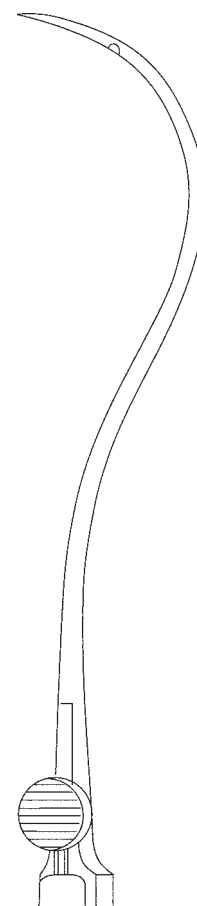

019-752-004
019-754-004

REVERDIN

019-752-001 - 019-752-004 19,0 cm / 7 1/2"
 019-754-001 - 019-754-004 23,0 cm / 9"



019

Unterbindungsnaedeln
Ligature Needles
Agujas para ligaduras
Aghi per legatura



Fig. 1
019-761-001

komplett mit Nadel Fig.1
complete with needle Fig.1
completo con aguja Fig.1
completo con ago Fig.1

YOUNG

019-760-240 24,0 cm / 9 1/2"

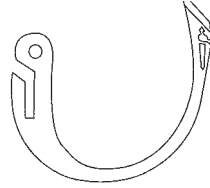

Fig. 2
019-761-002

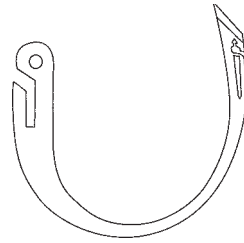
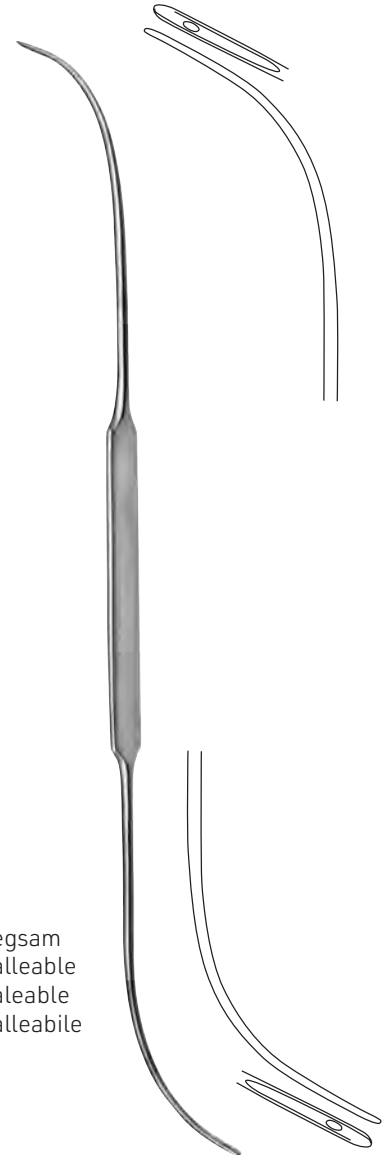

Fig. 3
019-761-003



SCHMIEDEN
019-771-240 24,0 cm / 9 1/2"



biegsam
malleable
maleable
malleabile

SCHMIEDEN-DICK
019-773-300 30,0 cm / 11 3/4"

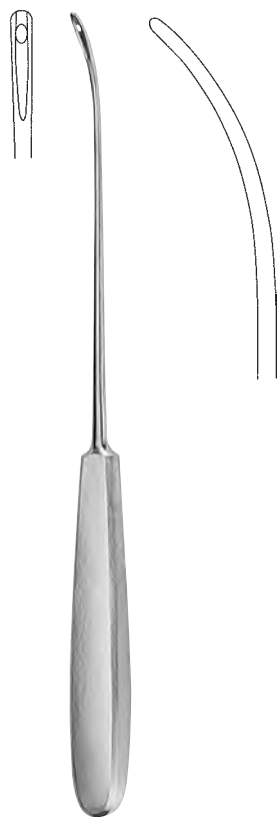

019-781-200 20,0 cm / 8"

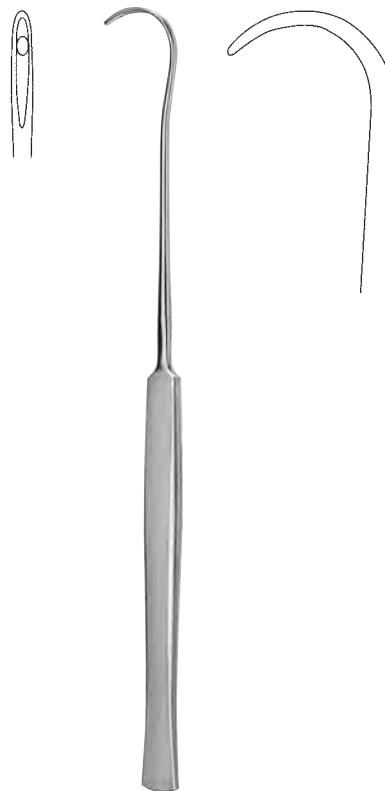

COOPER

019-783-190 19,0 cm / 7 1/2"

fein
 für die rechte Hand
 delicate
 for right hand
 fina
 para la mano derecha
 fino
 per la mano destra



KRONECKER

019-785-130 13,0 cm / 5 1/8"

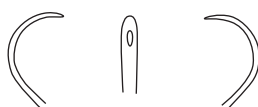

fein
 für die linke Hand
 delicate
 for left hand
 fina
 para la mano izquierda
 fino
 per la mano sinistra



KRONECKER

019-787-130 13,0 cm / 5 1/8"



019

Unterbindungsnadeln
Ligature Needles
Agujas para ligaduras
Aghi per legatura

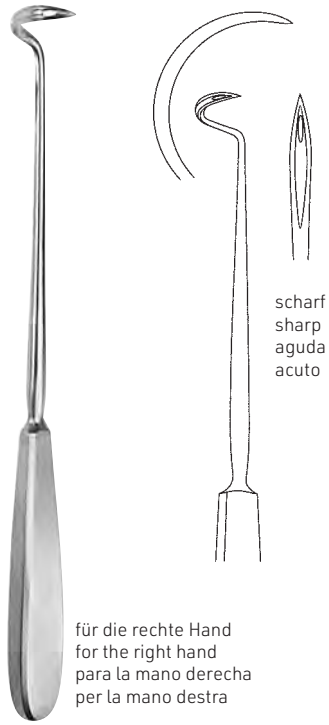

für die rechte Hand
for the right hand
para la mano derecha
per la mano destra

DESCHAMPS

019-800-200 20,0 cm / 8"

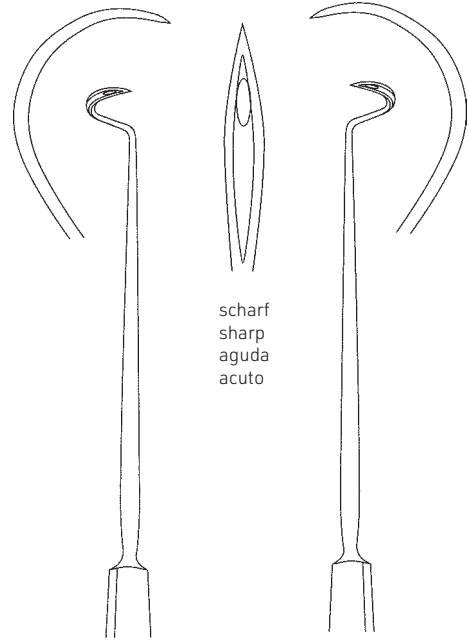

scharf
sharp
aguda
acuto

019-800-210
019-800-270

für die rechte Hand
for the right hand
para la mano derecha
per la mano destra

019-801-210
019-801-270

für die linke Hand
for the left hand
para la mano izquierda
per la mano sinistra

DESCHAMPS

019-800-210 - 019-801-210 21,0 cm / 8 1/4"
019-800-270 - 019-801-270 27,0 cm / 10 1/4"

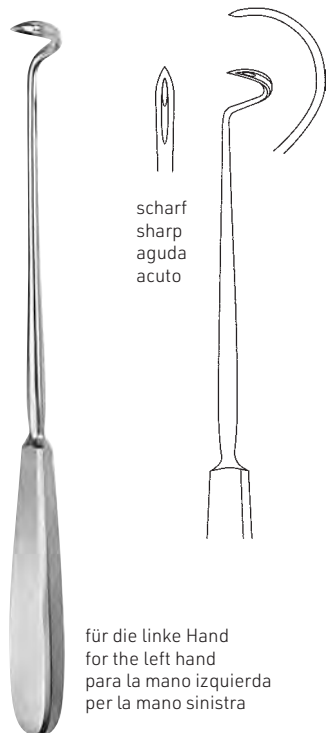

scharf
sharp
aguda
acuto

für die linke Hand
for the left hand
para la mano izquierda
per la mano sinistra

DESCHAMPS

019-801-200 20,0 cm / 8"

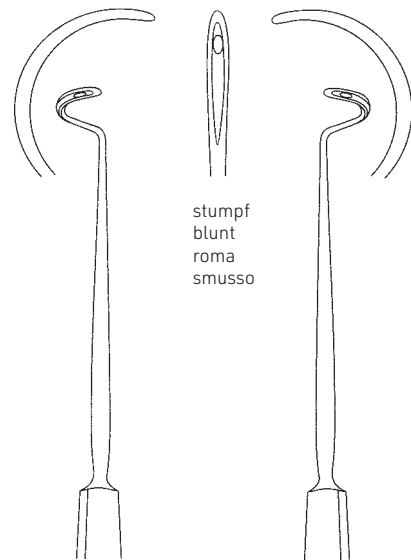

stumpf
blunt
roma
smusso

019-810-200

für die rechte Hand
for the right hand
para la mano derecha
per la mano destra

019-811-200

für die linke Hand
for the left hand
para la mano izquierda
per la mano sinistra

DESCHAMPS

20,0 cm / 8"

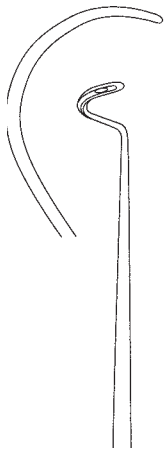

stumpf
 blunt
 roma
 smusso

019-810-210
019-810-240

für die rechte Hand
 for the right hand
 para la mano derecha
 per la mano destra

019-811-210
019-811-240

für die linke Hand
 for the left hand
 para la mano izquierda
 per la mano sinistra

DESCHAMPS

019-810-210 - 019-811-210 21,0 cm / 8¹/₄"
019-810-240 - 019-811-240 24,0 cm / 9¹/₂"

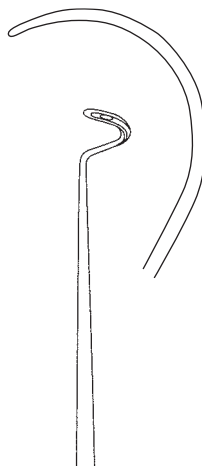
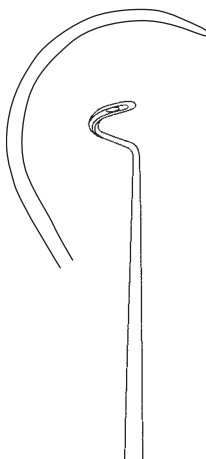

stumpf
 blunt
 roma
 smusso

019-810-270
019-810-280

für die rechte Hand
 for the right hand
 para la mano derecha
 per la mano destra

019-811-270
019-811-280

für die linke Hand
 for the left hand
 para la mano izquierda
 per la mano sinistra

DESCHAMPS

019-810-270 - 019-811-270 24,0 cm / 9¹/₂"
019-810-280 - 019-811-280 28,0 cm / 11"

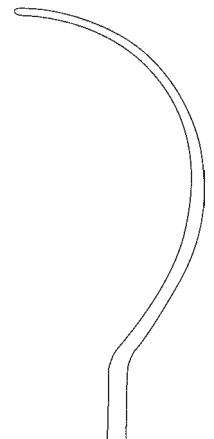

019-820-001

019-820-002

BRUNNER

019-820-001 - 019-820-002 30,0 cm / 11³/₄"



019

Unterbindungsadeln, Führungshohlsonden
Ligature Needles, Ligature Conductors
Agujas para ligaduras, Sondas conductoras
Aghi per legatura, Sonde conduttrici



019-824-001

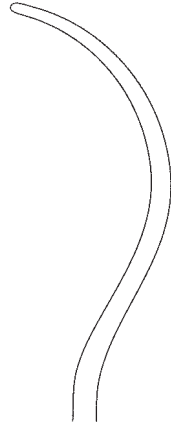

019-824-002

BRUNNER

019-824-001 - 019-824-002 30,0 cm / 11³/₄"

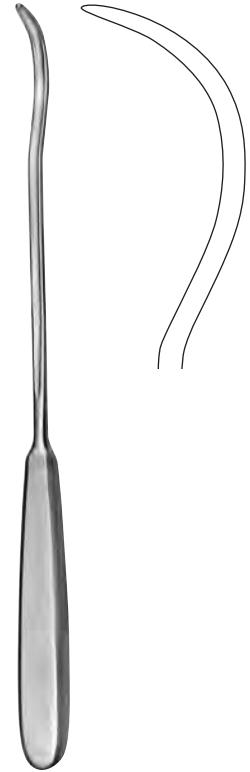

KIRSCHNER

019-829-255 25,5 cm / 10"

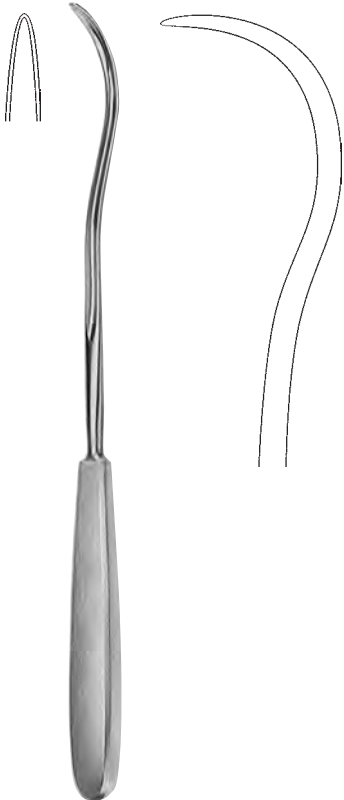

KIRSCHNER

019-829-280 28,0 cm / 11"

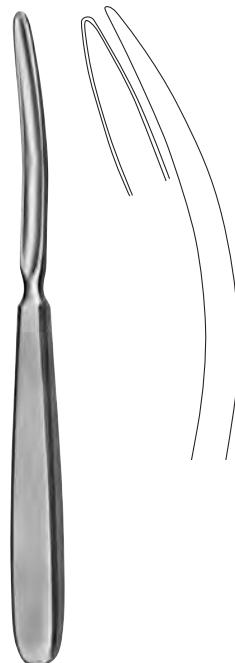

FRIMED

019-833-195 19,5 cm / 7³/₄"

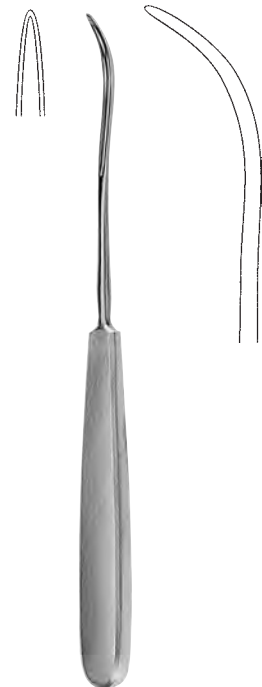

KÖNIG

019-841-001 19,5 cm / 7³/₄"

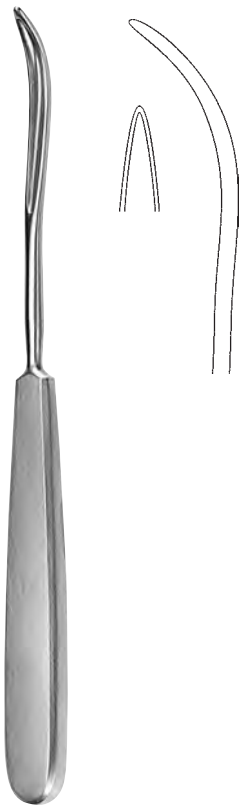

KÖNIG

019-841-002 19,5 cm / 7³/₄"

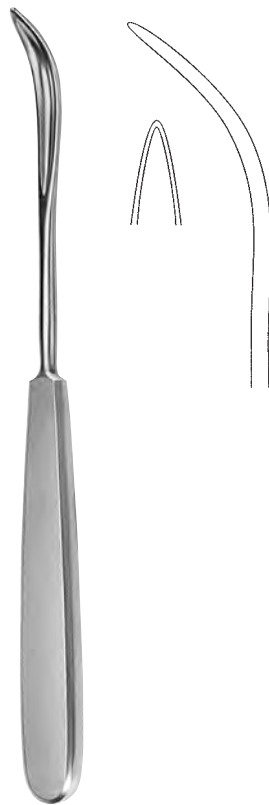

KÖNIG

019-841-003 19,5 cm / 7³/₄"

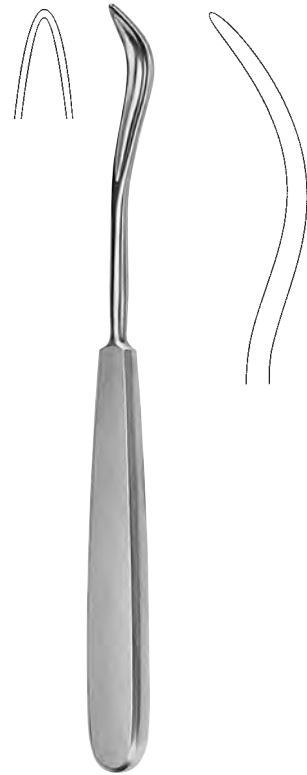

SCHMIEDEN

019-845-190 19,0 cm / 7¹/₂"

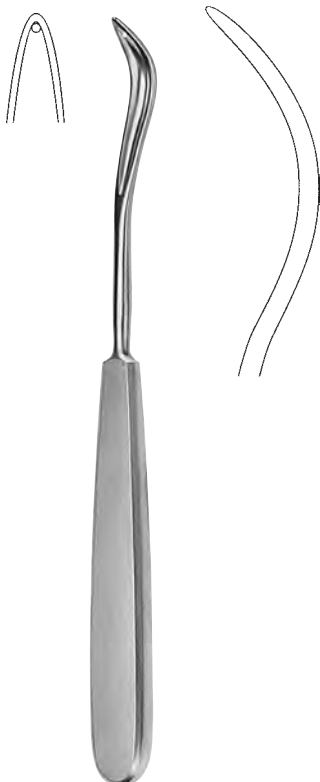

SCHMIEDEN-PAYR

019-847-190 19,0 cm / 7¹/₂"



PAYR

019-850-220 22,0 cm / 8⁵/₈"



PAYR

019-851-220 22,0 cm / 8⁵/₈"



019

Führungshohlsonden
Ligature Conductors
Sondas conductoras
Sonde conduttrici



MOD. WIEN

019-856-235 23,5 cm / 9¹/₄"



BOZEMANN

019-858-210 21,0 cm / 8¹/₄"



FRIMED

019-860-230 23,0 cm / 9"



BRUNNER

019-871-180 18,0 cm / 7"
019-871-270 27,0 cm / 10³/₄"



KIRSCHNER

019-873-270 27,0 cm / 10³/₄"



FERROZELL

019-875-190 19,0 cm / 7¹/₂"



FERROZELL

019-877-185 18,5 cm / 7¹/₄"



FERROZELL

019-878-240 24,0 cm / 9¹/₂"



kräftig, mit Klammerschiene
heavy pattern, with clip holder
modelo fuerte, con porta-agrafas
modello forte, con porta-agrafas

CHILDE

019-901-180 18,0 cm / 7"



MICHEL

019-902-120 12,0 cm / 4³/₄"



019

Wundklammerpinzetten, Wundklammerzangen

Clip Applying Forceps

Pinzas aplicadoras para agrafes

Pinze per applicare le agrafe

zum Anlegen und Abnehmen der Klammern
for applying and removal of clips
para aplicar y quitar agrafes
per applicare e togliere le agrafe



HEGENBARTH

019-904-120 12,0 cm / 4³/₄"



WACHENFELDT

019-906-125 12,5 cm / 5"



MICHEL

019-910-120 12,0 cm / 4³/₄"



langes Maul
long jaw
boca larga
morso lungo

MOD. MICHEL

019-912-120 12,0 cm / 4³/₄"

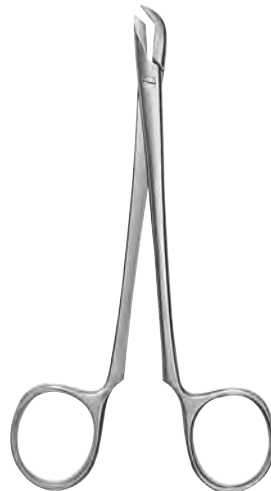

COLLIN

019-914-130 13,0 cm / 5"



RICHTER-HEATH

019-915-140 14,0 cm / 5¹/₂"



SET

019-930-000 130x45x18 mm

Wundklammer-Besteck, komplett, im Metalletui, bestehend aus:

- 1 Michel Wundklammerzängchen
- 1 Wachenfeldt Wundrand-Faßpinzette, mit Klammerhalter
- 50 Michel Wundklammern, 14 x 3 mm
- 1 Plastikschiutztasche

Suture Clip Set, complete, in metal case, consisting of:

- 1 Michel suture clip forceps
- 1 Wachenfeldt approximation forceps, with clip holder
- 50 Michel suture clips, 14 x 3 mm
- 1 protection pouch, plastic

Estuche de agrafes, completo, en caja metálica, compuesto de:

- 1 Michel pinza para agrafes
- 1 Wachenfeldt pinza aproximadora con porta-agrafes
- 50 Michel agrafes, 14 x 3 mm
- 1 bolsa de protecci3n, plástico

Set per sutura cutanea, completo, in contenitore metallico

- composto di:
- 1 pinza per agrafes Michel
 - 1 pinza Wachenfeldt per avvicinare i margini della ferrita, con port`agrafes
 - 50 agrafes Michel, 14 x 3 mm
 - 1 busta protettiva in plastica



019



020

Verband, Gips
Dressing, Plaster
Vendajes, Escayolas
Bendaggi, Gessatura



020

Verbandsscheren
Bandage Scissors
Tijeras de vendajes
Cesoie per bendaggi



LISTER

020-101-090	9,0 cm / 3 1/2"
020-101-110	11,0 cm / 4 3/8"
020-101-140	14,0 cm / 5 1/2"
020-101-160	16,0 cm / 6 1/4"
020-101-180	18,0 cm / 7"
020-101-200	20,0 cm / 8"



für Linkshänder
for left-handed
para zurdos
per mancini

LISTER

020-111-140	14,0 cm / 5 1/2"
020-111-180	18,0 cm / 7"
020-111-200	20,0 cm / 8"

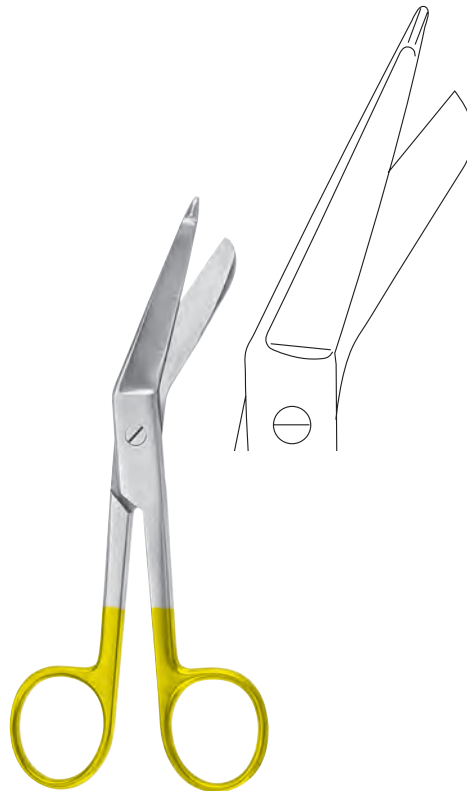

LISTER

020-115-140	14,0 cm / 5 1/2"
020-115-180	18,0 cm / 7"



LISTER

020-121-150 15,0 cm / 6"
020-121-180 18,0 cm / 7"



LISTER

020-131-150 15,0 cm / 6"
020-131-180 18,0 cm / 7"



LISTER

020-141-150 15,0 cm / 6"
020-141-180 18,0 cm / 7"



LISTER

020-151-150 15,0 cm / 6"
020-151-180 18,0 cm / 7"



LISTER

020-161-150 15,0 cm / 6"
020-161-180 18,0 cm / 7"



020

Verbandsschere
Bandage Scissors
Tijeras para vendajes
Cesoie per bendaggi



LISTER
020-171-200 20,0 cm / 8"



EXCENTRIC
020-181-160 16 cm / 5 1/2"



KNOWLES
020-190-140 14,0 cm / 5 1/2"



KNOWLES
020-191-140 14,0 cm / 5 1/2"

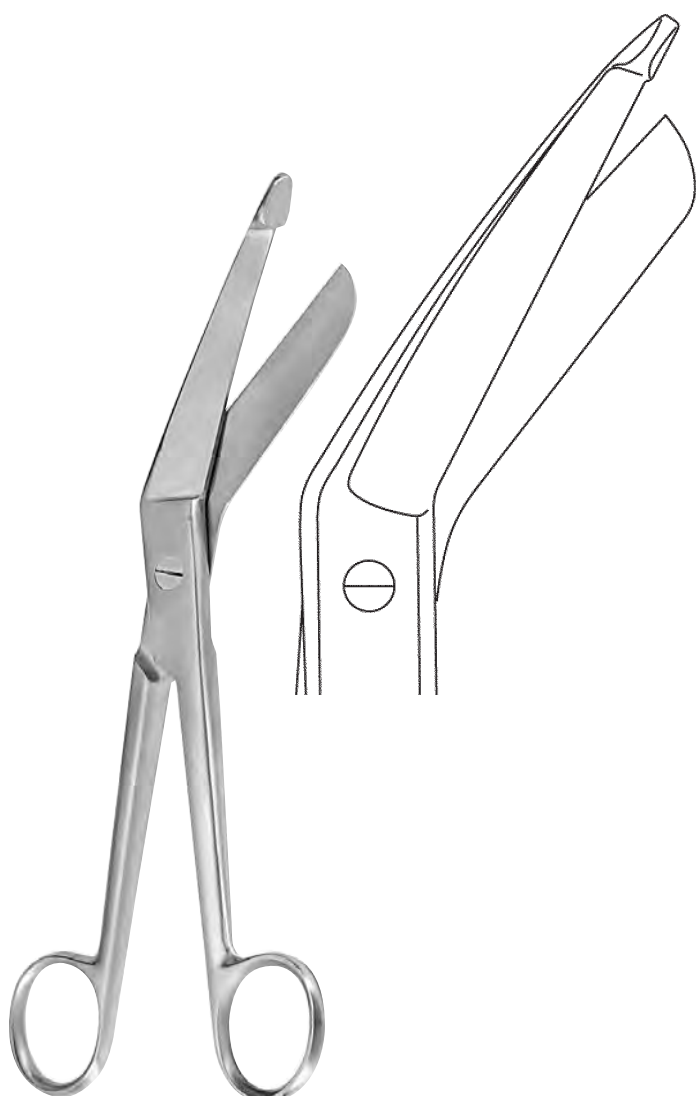

BERGMANN

020-201-230 23,0 cm / 9"

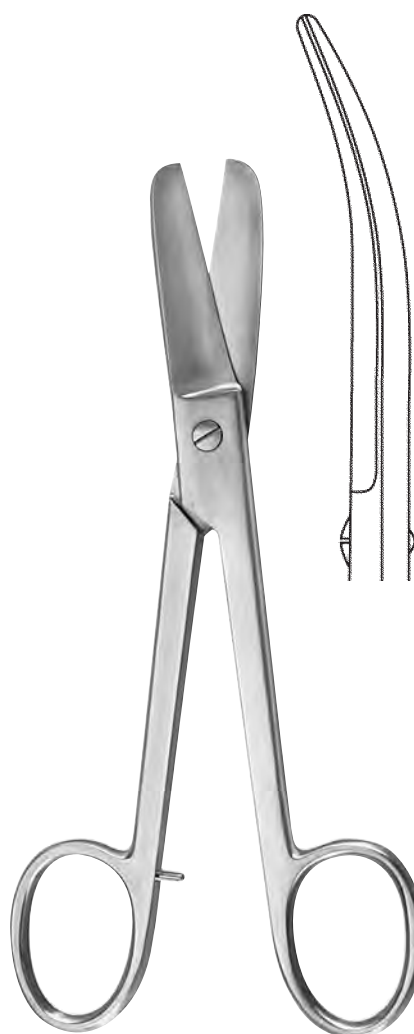

LORENZ

020-211-230 23,0 cm / 9"



020

Verbandsschere
Bandage Scissors
Tijeras para vendajes
Cesoie per bendaggi

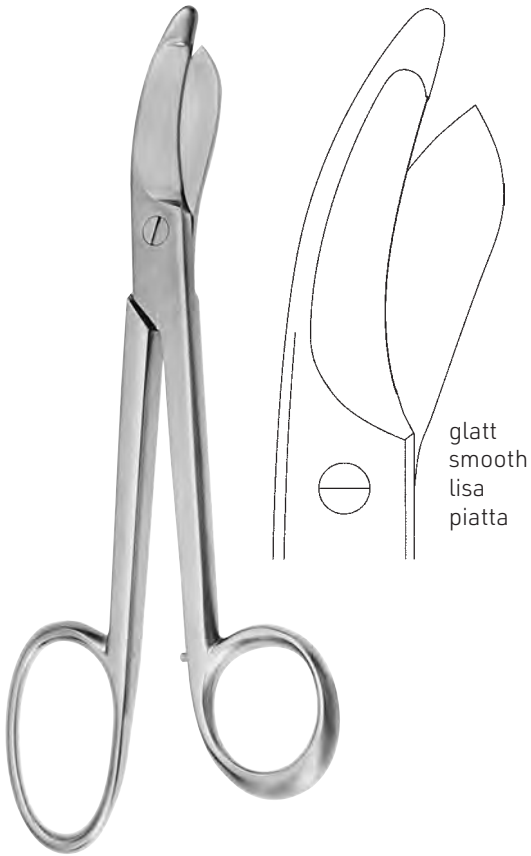

glatt
smooth
lisa
piatta

BRUNS

020-221-240 24,0 cm / 9 1/2"

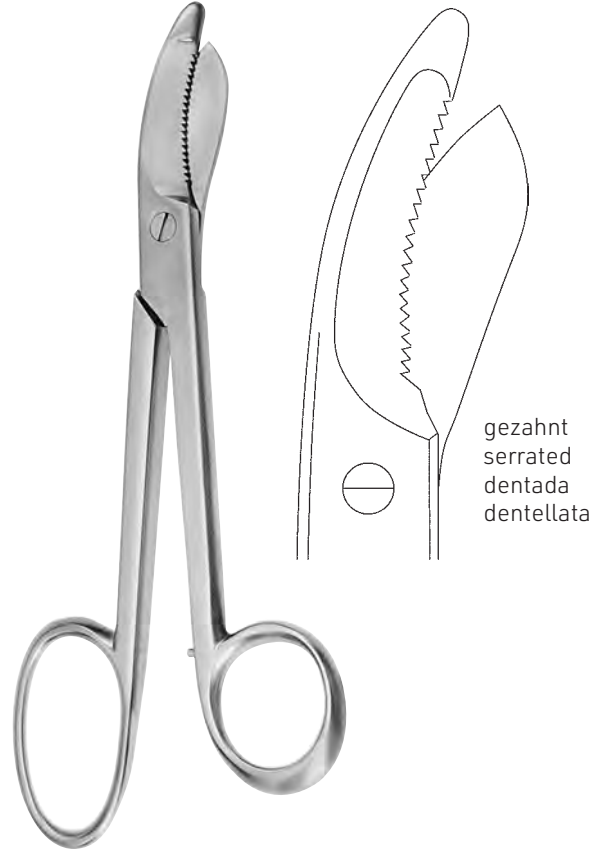

gezahnt
serrated
dentada
dentellata

BRUNS

020-231-240 24,0 cm / 9 1/2"

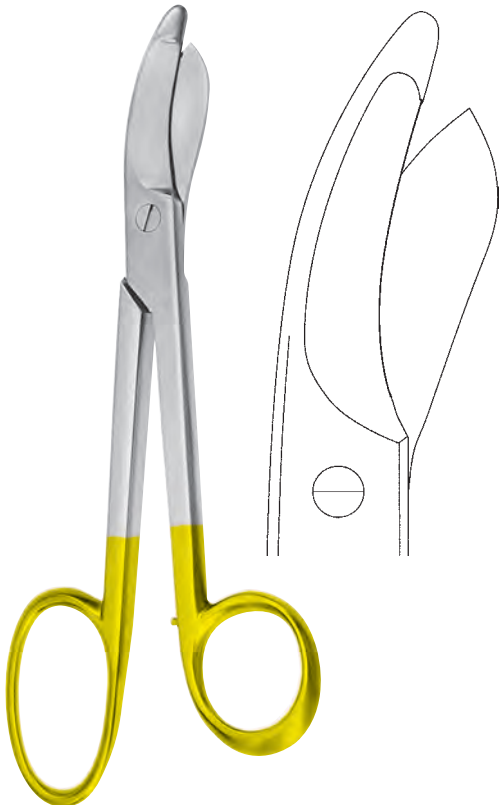

BRUNS

020-233-240 24,0 cm / 9 1/2"

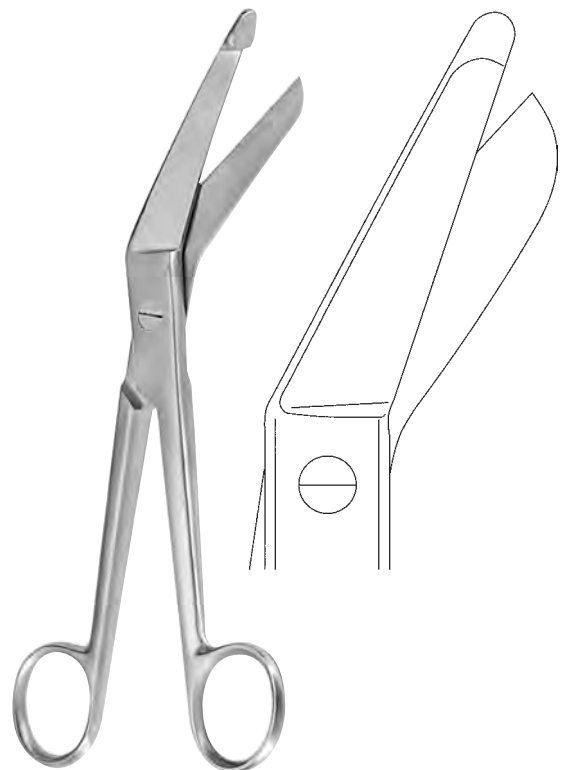

ESMARCH

020-241-200 20,0 cm / 8"
020-241-220 22,0 cm / 8 3/4"



SEUTIN

020-251-230 23,0 cm / 9"

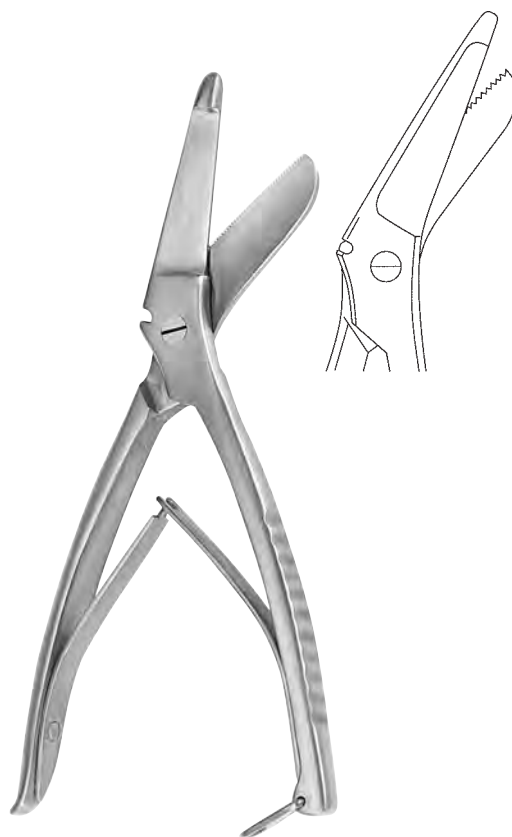

020-261-200 20,0 cm / 8"



STILLE

020-271-240 24,0 cm / 9 1/2"



STILLE

020-281-230 23,0 cm / 9"
020-281-260 26,0 cm / 10 1/4"
020-281-370 37,0 cm / 14 1/2"



020

Gipsmesser, Gipssägen
Plaster Knives , Plaster Saws
Cuchillos para escayolas, Sierras para escayolas
Coltelli per gessi, Seghe per gessi



ENGEL

020-301-140 14,0 cm / 5 1/2"



BERGMANN

020-311-180 18,0 cm / 7"



HOPKINS

020-320-200 20,0 cm / 8"



ESMARCH

020-330-180 18,0 cm / 7"



REINER

020-341-185 18,5 cm / 7 1/4"



MOD. USA

020-400-230 23,0 cm / 9"



HENNIG

020-410-280 28,0 cm / 11"



WOLFF

020-421-180 18,0 cm / 7"
020-421-240 24,0 cm / 9½"



020-421-180



020-421-240



020

Oszillierende Gipssäge
Oscillating Plaster Saw
Sierra oscilante para escayolas
Sega oscillante per gessi



020-500-110 110 Volt
020-500-230 230 Volt

komplett, mit 2 Spannschlüsseln (**020-530-000**),
1 Sägeblatt (**020-510-065**) und 1 Sägeblatt (**020-510-050**).

complete, with 2 spanners (**020-530-000**),
1 sawblade (**020-510-065**) and 1 sawblade (**020-510-050**).

completo, con 2 llaves (**020-530-000**),
1 hoja (**020-510-065**) y 1 hoja (**020-510-050**).

completo, con 2 chiavi (**020-530-000**),
1 lama (**020-510-065**) y 1 lama (**020-510-050**).

020-530-000

Spannschlüssel
Spanners
Llaves inglesas
Chiavi inglese

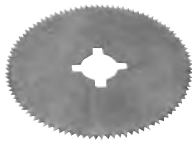

020-510-050 Ø 50 mm

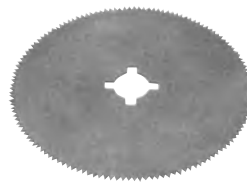

020-510-065 Ø 65 mm



020-520-050 Ø 50 mm

Spezialgehärtet
Special hardness
templada especial
tempra speciale

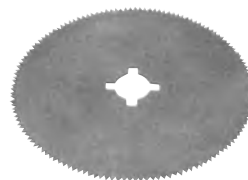

020-520-065 Ø 65 mm

Spezialgehärtet
Special hardness
templada especial
tempra speciale



021

Knochenchirurgie
Bone Surgery
Cirugía ósea
Chirurgia ossea



021

Amputations- und Resektionssägen
Amputation and Resection Saws
Sierras para amputación y resección
Seghe per amputazione e resezione



021-010-004 4 mm



021-010-006 6 mm

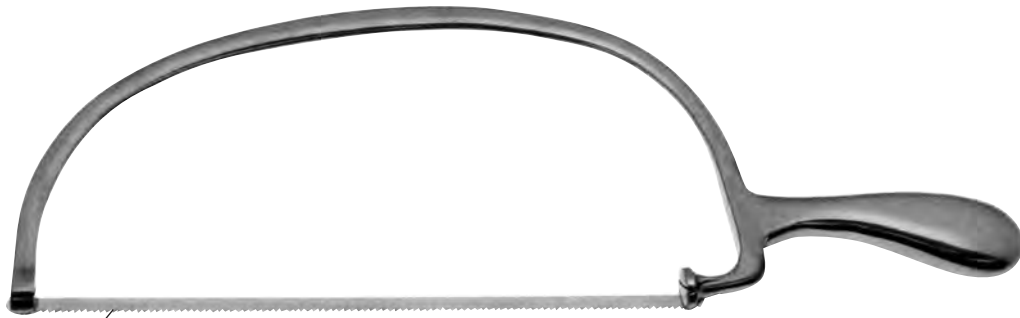

021-010-008 8 mm

BIER

021-010-000 40,5 cm / 16"

komplett
complete
completo
completo



021-020-012 12 mm



021-020-008 8 mm



021-020-006 6 mm



021-020-018 18 mm

RUST

021-020-000 39,0 cm / 15 1/2"

komplett mit 4 Sägeblättern (1 x 021-020-006, 1 x 021-020-008, 2 x 021-020-012)
complete with 4 Saw blades (1 x 021-020-006, 1 x 021-020-008, 2 x 021-020-012)
completo con 4 hojas de sierra (1 x 021-020-006, 1 x 021-020-008, 2 x 021-020-012)
completo con 4 lame di seghe (1 x 021-020-006, 1 x 021-020-008, 2 x 021-020-012)



021-030-012 12 mm

021-030-015 15 mm



021-030-018 18 mm

CHARRIÈRE

021-030-000 35,0 cm / 13³/₄"

komplett
 complete
 completo
 completo



LANGENBECK

021-032-235 23,5 cm / 9¹/₄"



CHARRIÈRE

021-034-270 27,0 cm / 10³/₄"

021-036-300 30,0 cm / 11³/₄"

021-037-001 20,0 cm / 8"

Ersatzblatt für 021-036-300
 Spareblade for 021-036-300
 hoja de repuesto para 021-036-300
 Lama di ricambio per 021-036-300

021-035-001 15,0 cm / 6"

Ersatzblatt für 021-034-270
 Spareblade for 021-034-270
 hoja de repuesto para 021-034-270
 Lama di ricambio per 021-034-270

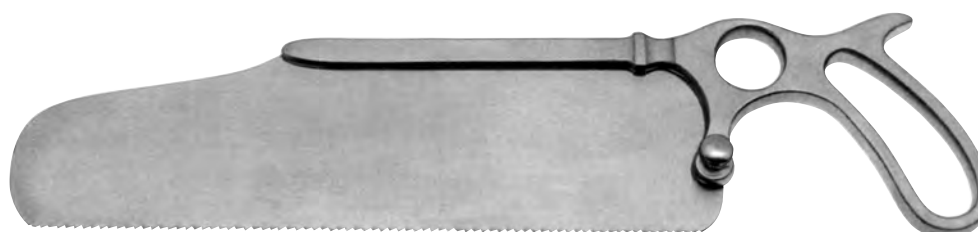

SATTERLEE

021-040-290 29,0 cm / 11¹/₄"

021-041-001 20,0 cm / 8"

Ersatzblatt
 Spareblade
 hoja de repuesto
 Lama di ricambio



021

Amputation
Amputation
Amputaciòn
Amputazione

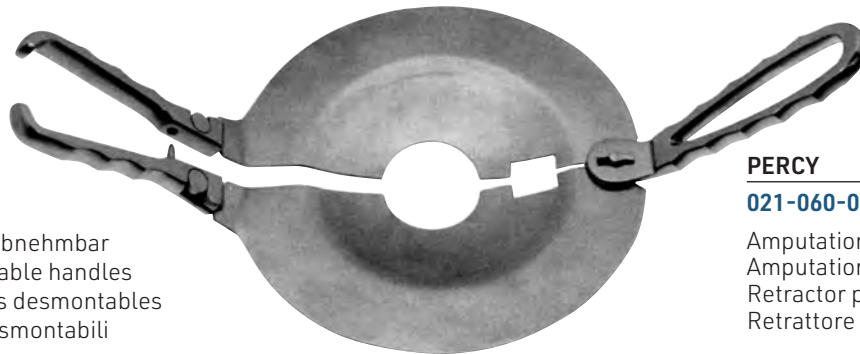

Griffe abnehmbar
Removable handles
Mangos desmontables
manici smontabili

PERCY

021-060-000

Amputationsretraktor
Amputation Retractor
Retractor para amputaciòn
Retrattore per amputazione

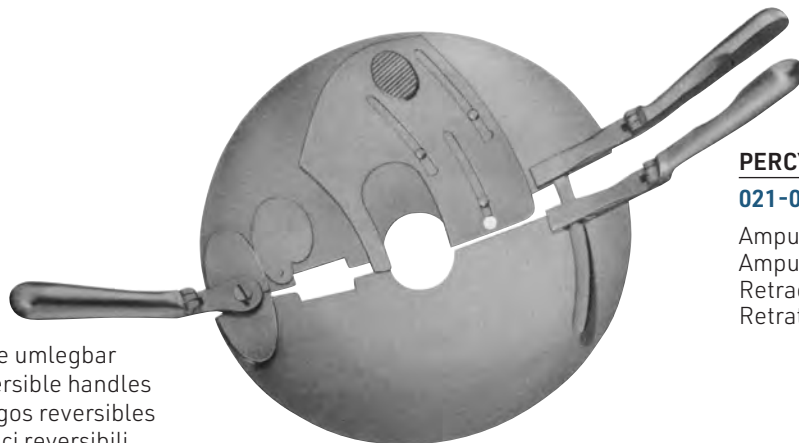

Griffe umlegbar
Reversible handles
Mangos reversibles
Manici reversibili

PERCY

021-062-000

Amputationsretraktor
Amputation Retractor
Retractor para amputaciòn
Retrattore per amputazione

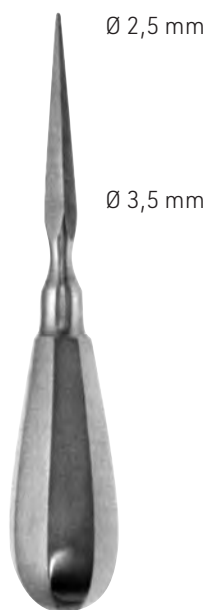

021-100-140 14,0 cm / 5½"
021-100-160 16,0 cm / 6¼"



PERTHES

021-110-180 18,0 cm / 7"



PERTHES

021-120-215 21,5 cm / 8½"



021-130-140 14,0 cm / 5½"



021

Handbohrapparate
Hand Bone Drills
Perforadores de mano
Trapani a mano per ossa

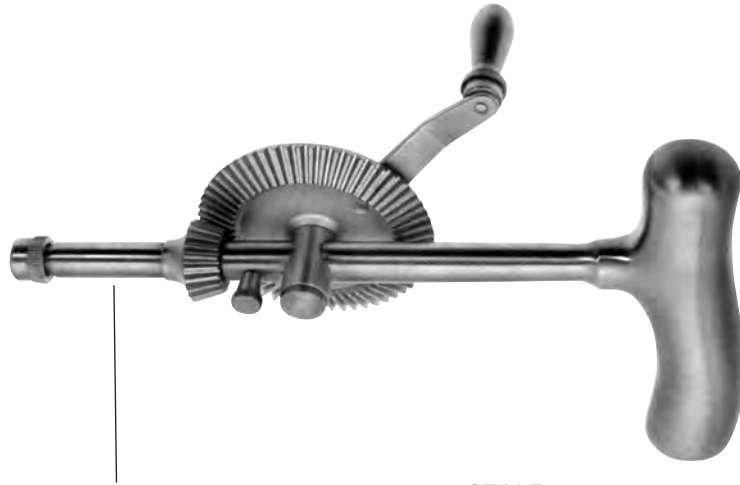

021-150-001

Handbohrapparat, allein
Hand Bone Drill, only
Perforadore de mano, suelta
Trapano a mano per ossa, solo

STILLE

021-150-000

komplett mit 4 Bohrer, 4 Fräsern, 1 Trepine
complete with 4 drills, 4 burrs, 1 trephine
completo con 4 taladros, 4 fresas, 1 trepano
completo con 4 punte, 4 frese sferica, 1 fresa



021-151-010 Ø 1,0 mm



021-151-015 Ø 1,5 mm



021-151-020 Ø 2,0 mm



021-151-025 Ø 2,5 mm



021-151-030 Ø 3,0 mm



021-151-035 Ø 3,5 mm



021-151-040 Ø 4,0 mm



021-152-010 Ø 10,0 mm



021-154-005 Ø 5,0 mm



021-154-008 Ø 8,0 mm



021-154-012 Ø 12,0 mm



021-154-016 Ø 16,0 mm



HUDSON

021-160-001

Handbohrapparat mit Schnellverschluß, allein
Hand Bone Drill with quick lock, only
Perforador de mano con cierre rapido, suelto
Trapano a mano con chiusura presta, solo

HUDSON

021-160-000

(021-160-001 + 021-160-002 + 021-162-009 + 021-162-014 + 021-162-016)

komplett mit Verlängerungsstück und 4 Fräsern
complete with extension piece and 4 burrs
completo con pieza de prolongacion y 4 fresas
completo con giunto di prolungamento e 4 frese



021-160-002

Verlängerungsstück
Extension piece
Pieza de prolongaciòn
Giunto di prolungamento



021-162-009 Ø 9,0 mm



021-162-014 Ø 14,0 mm



021-162-016 Ø 16,0 mm



021-162-022 Ø 22,0 mm



CUSHING

021-164-013 Ø 13,0 mm



ADSON

021-165-024 Ø 2,4 mm



MC KENZIE

021-166-013 Ø 13,0 mm



D`ERRICO

021-167-016 Ø 16,0 mm

021-171-000

Spannschlüssel, allein
Wrench, only
Llave, suelta
Chiave, sola



021-170-160 16,0 cm / 6 1/4"



021

Handbohrapparate
Hand Bone Drills
Perforadores de mano
Trapani a mano per ossa



BUNNELL

021-180-000

längsdurchgebohrt, zur Aufnahme von Bohrdrähten und Nägeln
cannulated, for taking wire drills and nails
barrenado oblongo, para agujas y clavos
tubolare, per inserire fili e chiodi



021-171-000

Spannschlüssel, allein
Wrench, only
Llave, suelta
Chiave, sola

RALK

021-190-000

längsdurchgebohrt, zur Aufnahme von Bohrdrähten und Nägeln
cannulated, for taking wire drills and nails
barrenado oblongo, para agujas y clavos
tubolare, per inserire fili e chiodi



LOWMAN

021-200-120	12,0 cm / 4 ³ / ₄ "	a = 19,0 mm
021-200-180	18,0 cm / 7"	a = 25,0 mm
021-200-200	20,0 cm / 8"	a = 29,0 mm

LOWMAN

021-210-120	12,0 cm / 4 ³ / ₄ "	a = 19,0 mm
021-210-180	18,0 cm / 7"	a = 25,0 mm
021-210-200	20,0 cm / 8"	a = 29,0 mm
021-210-220	22,0 cm / 8 ³ / ₄ "	a = 31,0 mm



021

Knochenhalteklammern
Bone Holding Clamps
Grapas porta-huesos
Tenaglie per ossa



a = 29,0 mm



LOWMAN-LAMBERT

021-220-210 21,0 cm // 8 1/4"



a = 25,0 mm

1 Maulteil beweglich
1 jaw swiveled
1 boca movable
1 musso mobile

LOWMAN-HOGLUND

021-230-180 18,0 cm // 7"

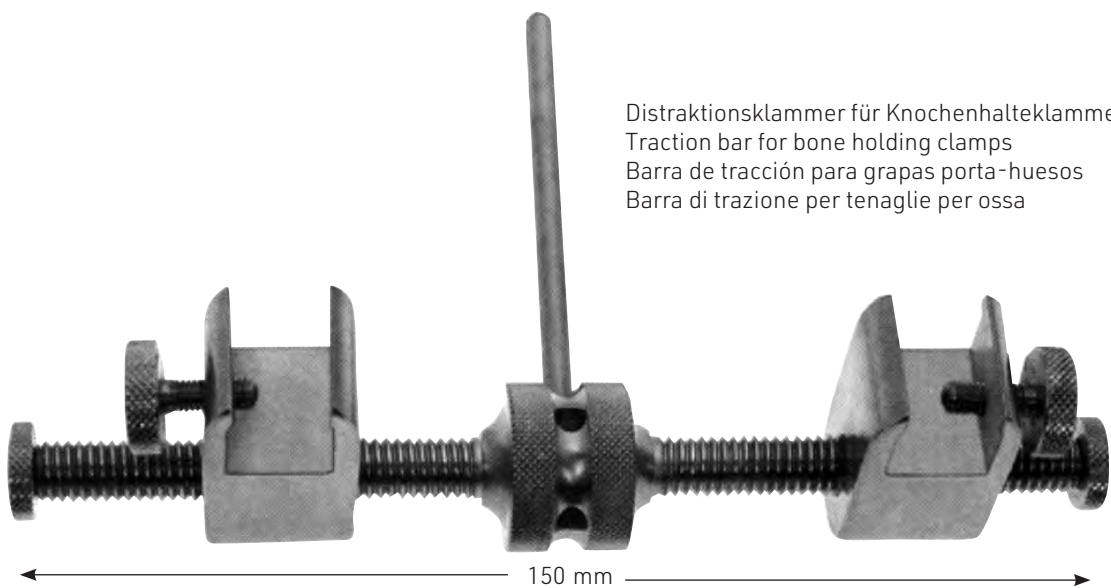

Distractionsklammer für Knochenhalteklammern
Traction bar for bone holding clamps
Barra de tracción para grapas porta-huesos
Barra di trazione per tenaglie per ossa

GERSTER

021-240-150

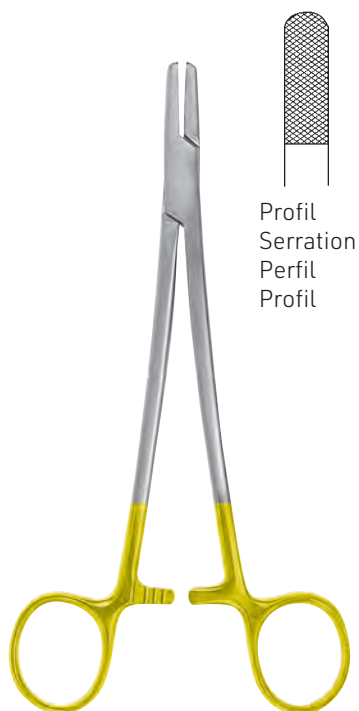

Profil
 Serration
 Perfil
 Profil

BARRY-STERNDAL

021-250-185 18,5 cm / 7¹/₄"



Profil
 Serration
 Perfil
 Profil

021-260-150 15,0 cm / 6"
021-260-200 20,0 cm / 8"

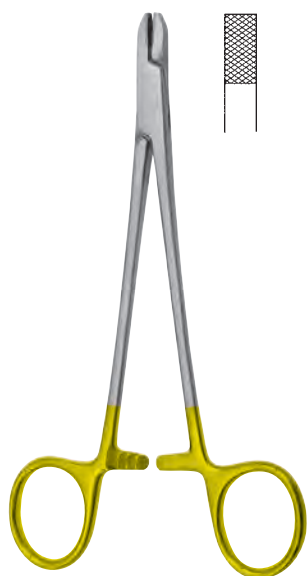

021-270-150 15,0 cm / 6"
021-270-200 20,0 cm / 8"



Profil
 Serration
 Perfil
 Profil

CROWIN-HEGAR
021-280-160 16,0 cm / 6¹/₄"



021

Drahtfasszangen, Flachzangen
 Wire Holding Forceps, Flat Nose Pliers
 Alicates para extraer alambres, Alicates de pico plano
 Tenaglie porta cavo, Tenaglie piate

mit Längsrille
 with longitudinal groove
 con ranura longitudinal
 con scannelatura longitudinale



021-300-140 14,0 cm / 5 1/4"

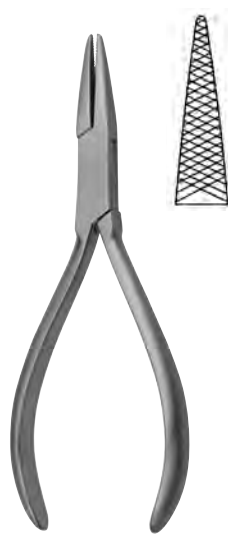

021-304-140 14,0 cm / 5 1/4"



HACKSTOCK
021-306-160 16,0 cm / 6 1/4"



021-310-180 18,0 cm / 7"

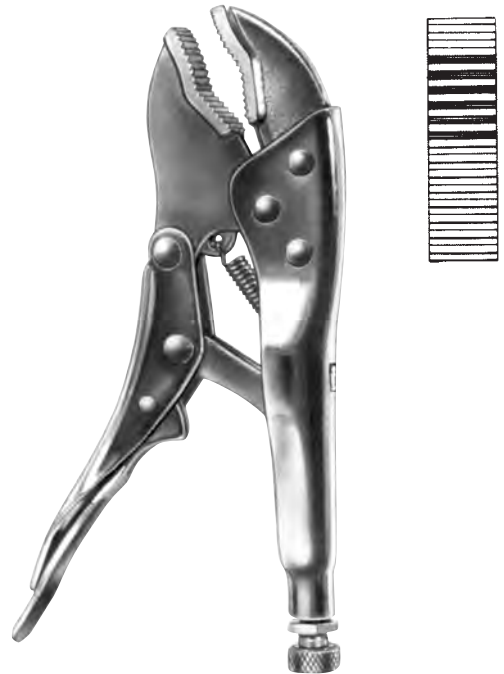

021-320-180 18,0 cm / 7"



021-330-001 17,0 cm / 6³/₄"



mit Kreuzrille
 with crosswire groove
 con ranura en forma de cruz
 con scannatura a croce

021-330-002 17,0 cm / 6³/₄"

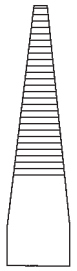

021-340-190 19,0 cm / 7¹/₂"



021-350-150 15,0 cm / 6"

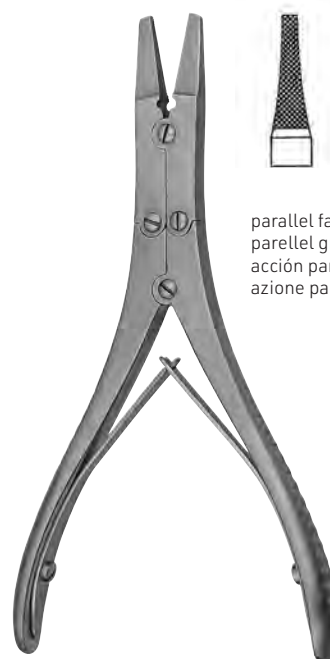

parallel fassend
 pallel grip
 acción paralela
 azione parallela

021-378-145 14,5 cm / 5³/₄"



021

Drahtfasszangen
Wire Holding Forceps
Alicates para extraer alambres
Tenaglie porta cavo

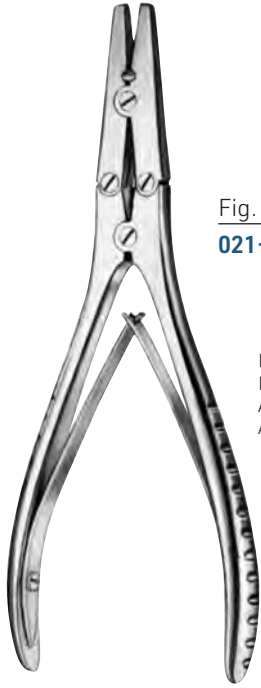

Fig. 1
021-380-001



Fig. 2
021-380-002



Fig. 3
021-380-003

Parallelschluß
Parallel action
Acciòn paralela
Azione parallela

021-380-001 - 021-380-003 18,0 cm / 7"



021-382-180 18,0 cm / 7"

TC



Fig. 1
021-390-001



Fig. 2
021-390-002



Fig. 3
021-390-003

Parallelschluß
Parallel action
Acciòn paralela
Azione parallela

021-390-001 - 021-390-003 18,0 cm / 7"



für weiche Drähte bis 2,4 mm Ø
for soft wires up to 2,4 mm Ø
para alambres blandos hasta 2,4 mm Ø
per fili molli fino a 2,4 mm Ø

für harte Drähte bis 1,6 mm Ø
for hard wires up to 1,6 mm Ø
para alambres duros hasta 1,6 mm Ø
per fili metallici duri fino a 1,6 mm Ø

021-400-185 18,5 cm / 7¹/₄"



Kopfschneider
Wire Cutter, front action
Alicate frontal para corta alambre
Tegnalie tagliafili frontali

für weiche Drähte bis 2,2 mm Ø
for soft wires up to 2,2 mm Ø
para alambres blandos hasta 2,2 mm Ø
per fili molli fino a 2,2 mm Ø

für harte Drähte bis 2,0 mm Ø
for hard wires up to 2,0 mm Ø
para alambres duros hasta 2,0 mm Ø
per fili metallici duri fino a 2,0 mm Ø

FRIMED-DIAMANT

021-410-160 16,0 cm / 6¹/₄"



für weiche Drähte bis 0,6 mm Ø
for soft wires up to 0,6 mm Ø
para alambres blandos hasta 0,6 mm Ø
per fili molli fino a 0,6 mm Ø

für harte Drähte bis 0,4 mm Ø
for hard wires up to 0,4 mm Ø
para alambres duros hasta 0,4 mm Ø
per fili metallici duri fino a 0,4 mm Ø

TC



021-420-125 12,5 cm / 5"



021-420-470 47,0 cm / 18¹/₄"

Bolzenschneider zum Abzwicken von Drähten, Schrauben und Nägeln bis Ø 6 mm
Cutters for cutting of wires, screws and pins up to diam, 6 mm
Alicates corta-alambres, tornillos y clavos hasta Ø 6 mm
Cesoia per cavi, viti e perni, con Ø superiore a 6 mm



021

TC-Drahtkneifzangen
TC-Wire Cutting Pliers
TC-Alicates corta-alambres
TC-Tenaglie tagliafili



für weiche Drähte bis 2,0 mm Ø
for soft wires up to 2,0 mm Ø
para alambres blandos hasta 2,0 mm Ø
per fili molli fino a 2,0 mm Ø

für harte Drähte bis 1,7 mm Ø
for hard wires up to 1,7 mm Ø
para alambres duros hasta 1,7 mm Ø
per fili metallici duri fino a 1,7 mm Ø

021-430-185 18,5 cm / 7¹/₄"

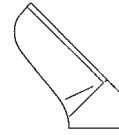

021-440-175

für weiche Drähte bis 2,0 mm Ø
for soft wires up to 2,0 mm Ø
para alambres blandos hasta 2,0 mm Ø
per fili molli fino a 2,0 mm Ø

für harte Drähte bis 1,7 mm Ø
for hard wires up to 1,7 mm Ø
para alambres duros hasta 1,7 mm Ø
per fili metallici duri fino a 1,7 mm Ø

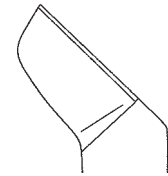

021-440-220

für weiche Drähte bis 2,8 mm Ø
for soft wires up to 2,8 mm Ø
para alambres blandos hasta 2,8 mm Ø
per fili molli fino a 2,8 mm Ø

für harte Drähte bis 2,2 mm Ø
for hard wires up to 2,2 mm Ø
para alambres duros hasta 2,2 mm Ø
per fili metallici duri fino a 2,2 mm Ø

021-440-175 17,5 cm / 7"
021-440-220 22,0 cm / 8³/₄"



Kopf- und Seitenschneider
Wire Cutting Plier
Alicate para cortar alambre
Tenaglia tagliafili

für weiche Drähte bis 2,0 mm Ø
for soft wires up to 2,0 mm Ø
para alambres blandos hasta 2,0 mm Ø
per fili molli fino a 2,0 mm Ø

für harte Drähte bis 1,7 mm Ø
for hard wires up to 1,7 mm Ø
para alambres duros hasta 1,7 mm Ø
per fili metallici duri fino a 1,7 mm Ø

021-450-180 18,0 cm / 7"



für harte Drähte bis 2,2 mm Ø
 for hard wires up to 2,2 mm Ø
 para alambre duros hasta 2,2 mm Ø
 per fill duri fino a 2,2 mm Ø

021-460-180 18,0 cm / 7"



021-460-230

für harte Drähte bis 3,0 mm Ø
 for hard wires up to 3,0 mm Ø
 para alambre duros hasta 3,0 mm Ø
 per fill duri fino a 3,0 mm Ø

021-460-280

für harte Drähte bis 2,0 - 3,5 mm Ø
 for hard wires up to 2,0 - 3,5 mm Ø
 para alambre duros hasta 2,0 - 3,5 mm Ø
 per fill duri fino a 2,0 - 3,5 mm Ø

021-460-230 23,0 cm / 9"
021-460-280 28,0 cm / 11"



Ersatzteilset: 1 Paar TC-Ersatzschneiden,
 2 Paar Schrauben, 1 Inbusschlüssel
Spare Part Set: 1 pair of TC-blades, 2 pairs
 of screws, 1 Allen key
Juego de recambio: 1 par de placas de
 Tungsteno, 2 pares de tornillos, 1 llave
 Hexagonal
Set di ricambio: 1 paio di lami di TC,
 2 paio di viti, 1 chiave a brugola

021-461-001 für/for/para/per 021-460-180
021-461-002 für/for/para/per 021-460-230 und -280



Ersatzteilset: 1 Paar Gummibacken,
 1 Paar Schrauben, 1 Schraubendreher
Spare Part Set: 1 pair of rubber jaws,
 1 pair of screws, 1 Screwdriver
Juego de recambio: 1 par de bocas de
 goma, 1 par de tornillos, 1 destornillador
Set di ricambio: 1 paio di guance
 di plastica, 1 Cacciavite

021-461-003 für/for/para/per 021-460-180,
 021-460-230 und -280



für weiche Drähte bis 3,0 mm Ø
 for soft wires up to 3,0 mm Ø
 para alambre blandos hasta 3,0 mm Ø
 per fili molli fino a 3,0 mm Ø

für harte Drähte bis 2,0 mm Ø
 for hard wires up to 2,0 mm Ø
 para alambre duros hasta 2,0 mm Ø
 per fili duri fino a 2,0 mm Ø

021-470-220 22,0 cm / 8³/₄"



021

Drähte, Drahtspanner, Drahtspannzange
Bone Wires, Wire Tightener, Wire Twisting Forceps
Alambres para huesos, Tensor cierra-hilo, Pinza cierra-hilo
Fili per ossa, Trenditore serra filo, Pinza gira cavo

Cerclage-Drähte, weich, in Ringen zu 10 m
Bone wires, soft, in coils of 10 m
Hilos de cerclaje, blandos, en rollos de 10 m
Filo per ossa, leggero, inrotolo di 10 m



021-500-002	Ø 0,2 mm
021-500-003	Ø 0,3 mm
021-500-004	Ø 0,4 mm
021-500-005	Ø 0,5 mm
021-500-006	Ø 0,6 mm
021-500-007	Ø 0,7 mm
021-500-008	Ø 0,8 mm
021-500-009	Ø 0,9 mm
021-500-010	Ø 1,0 mm
021-500-012	Ø 1,2 mm
021-500-015	Ø 1,5 mm



Drahtspanner mit an der Spitze
eingebauter beweglicher Drahtspannbüchse
für Cerclage-Drähte bis ø 1 mm

Wire tightener, with movable tip, for wires up
to 1,0 mm diam.

Teñsor cierra-hilo con manguito movable en la
punta, para hilos de cerclaje hasta ø 1 mm

Trenditore serra filo con manico mobile sulla
punta, per fili di cerchiaggio da 1 mm, di ø

LOUTE

021-510-210 21,0 cm / 8¹/₄"



DEMEL

021-520-270 27,0 cm / 10³/₄"

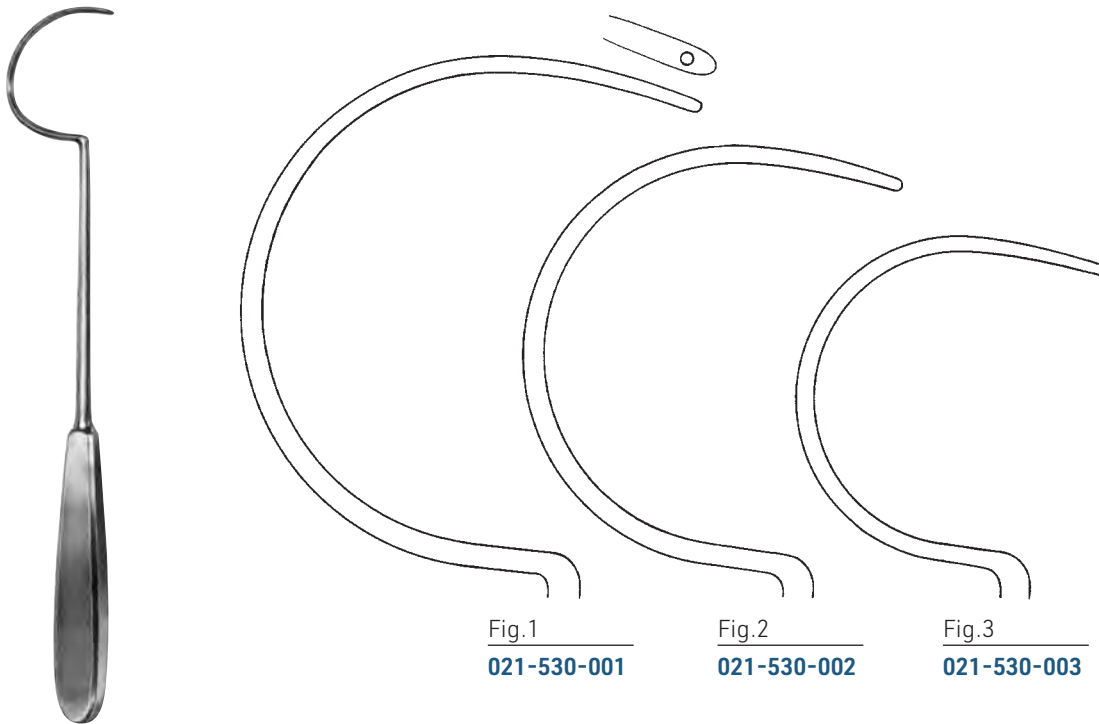

Fig.1
021-530-001

Fig.2
021-530-002

Fig.3
021-530-003

DEMEL

- 021-530-001** 31,0 cm / 12¹/₄"
- 021-530-002** 29,0 cm / 11¹/₄"
- 021-530-003** 28,0 cm / 11"

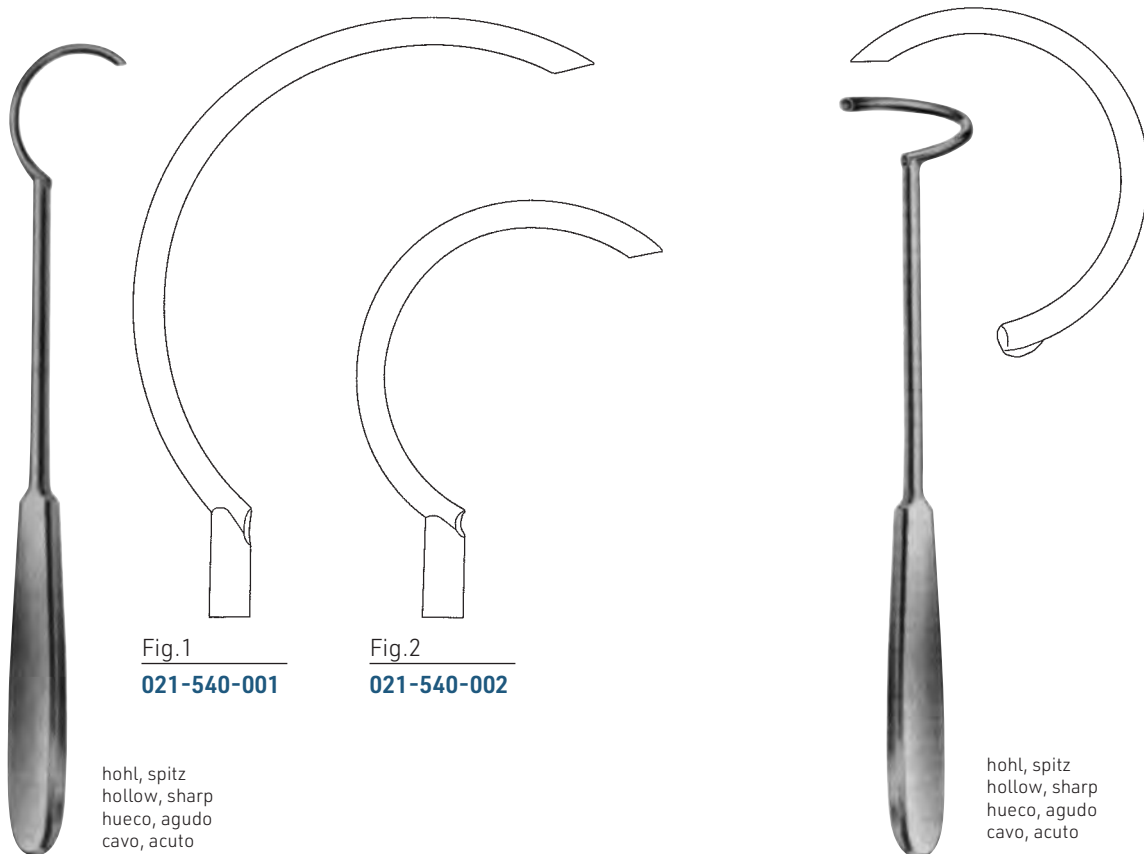

Fig.1
021-540-001

Fig.2
021-540-002

hohl, spitz
 hollow, sharp
 hueco, agudo
 cavo, acuto

hohl, spitz
 hollow, sharp
 hueco, agudo
 cavo, acuto

- 021-540-001** 27,0 cm / 10³/₄"
- 021-540-002** 24,0 cm / 9¹/₂"

- 021-544-225** 22,5 cm / 9"



021

Bohrhandgriff
Drill handle
Perforador de mano
Perforatore a mano



VICKERS-EASYDRIVER

021-598-140 14,0 cm / 5 1/2"



STEINMANN

021-600-080	Ø 4,0 x 80 mm
021-600-100	Ø 4,0 x 100 mm
021-600-120	Ø 4,0 x 120 mm
021-600-140	Ø 4,0 x 140 mm
021-600-150	Ø 4,0 x 150 mm
021-600-160	Ø 4,0 x 160 mm
021-600-180	Ø 4,0 x 180 mm
021-600-200	Ø 4,0 x 200 mm
021-600-210	Ø 4,0 x 210 mm
021-600-250	Ø 4,0 x 250 mm

Spannschlüssel mit Klemmbacke
 Wire tightener, with clamping jaws
 Tensor de alambres
 Strumento tenditore con morso a presa



021-661-000



Extensionsbügel mit 3 Zughaken, zur Verwendung mit KIRSCHNER Drähten bis Ø 2,5 mm.

Wire traction bows with 3 Traction hooks, to be used with KIRSCHNER wires up to 2,5 mm diam.

Estribos para extensión con 3 ganchos de tracción, para agujas de KIRSCHNER hasta Ø 2,5 mm.

Archi per trazione con 3 ganci di trazione, da impiegarsi con fili KIRSCHNER superiori a 2,5 mm di Ø.

KIRSCHNER

	a	b	
021-660-001	95 mm	70 mm	für Arm und Ellenbogen / for arm and elbow / para brazo y codo / per braccio e gomito
021-660-002	95 mm	110 mm	für Fersenbein / for clacaneus / para calcáneo / per calcagno
021-660-003	105 mm	100 mm	für Knie / for knee / para rodilla / per ginocchio
021-660-004	120 mm	120 mm	für Knie / for knee / para rodilla / per ginocchio
021-660-005	135 mm	130 mm	für Knie / for knee / para rodilla / per ginocchio
021-660-006	155 mm	155 mm	für Oberschenkel / for femur / para fémur / per femore
021-660-007	200 mm	155 mm	für Hüfte / for hip / para coxa / per anca



021

KIRSCHNER Bohrdrähte
KIRSCHNER Wire Drills
Brocas filiformes KIRSCHNER
Punte filiformi di KIRSCHNER



Bohrdrähte mit beidseitiger Trokarspitze, in Packungen zu 10 Stk.
Wire drills with trocar point on each end, in packages of 10 pieces
Agujas con dos puntas trocar, en paquete de 10 piezas
Punte trequarti a punta ciascun lato, in confezioni da 10 pezzi

für Drähte mit
for wires with
para agujas con
per punte con

KIRSCHNER

6,0 cm / 2 1/2"	10,0 cm / 4"	12,0 cm / 4 3/4"	14,0 cm / 4 3/4"	16,0 cm / 6 1/4"	31,0 cm / 12 1/4"	
021-700-008	021-702-008	021-704-008	021-706-008	021-708-008	021-710-008	Ø 0,8 mm
021-700-010	021-702-010	021-704-010	021-706-010	021-708-010	021-710-010	Ø 1,0 mm
021-700-012	021-702-012	021-704-012	021-706-012	021-708-012	021-710-012	Ø 1,2 mm
021-700-014	021-702-014	021-704-014	021-706-014	021-708-014	021-710-014	Ø 1,4 mm
021-700-015	021-702-015	021-704-015	021-706-015	021-708-015	021-710-015	Ø 1,5 mm
021-700-016	021-702-016	021-704-016	021-706-016	021-708-016	021-710-016	Ø 1,6 mm
021-700-018	021-702-018	021-704-018	021-706-018	021-708-018	021-710-018	Ø 1,8 mm
021-700-020	021-702-020	021-704-020	021-706-020	021-708-020	021-710-020	Ø 2,0 mm
021-700-022	021-702-022	021-704-022	021-706-022	021-708-022	021-710-022	Ø 2,2 mm
021-700-025	021-702-025	021-704-025	021-706-025	021-708-025	021-710-025	Ø 2,5 mm
021-700-030	021-702-030	021-704-030	021-706-030	021-708-030	021-710-030	Ø 3,0 mm



Bohrdrähte mit Trokarspitze und rundem Schaftende, in Packungen zu 10 Stk.
Wire drills with trocar point and round shaft end, in packages of 10 pieces
Agujas con punta trocar y cabo redondo, en paquetes de 10 piezas
Punte trequarti a punta, estremita rotonda, in confezioni da 10 pezzi

für Drähte mit
for wires with
para agujas con
per punte con

KIRSCHNER

6,0 cm / 2 1/2"	10,0 cm / 4"	12,0 cm / 4 3/4"	14,0 cm / 4 3/4"	16,0 cm / 6 1/4"	31,0 cm / 12 1/4"	
021-720-008	021-722-008	021-724-008	021-726-008	021-728-008	021-730-008	Ø 0,8 mm
021-720-010	021-722-010	021-724-010	021-726-010	021-728-010	021-730-010	Ø 1,0 mm
021-720-012	021-722-012	021-724-012	021-726-012	021-728-012	021-730-012	Ø 1,2 mm
021-720-014	021-722-014	021-724-014	021-726-014	021-728-014	021-730-014	Ø 1,4 mm
021-720-015	021-722-015	021-724-015	021-726-015	021-728-015	021-730-015	Ø 1,5 mm
021-720-016	021-722-016	021-724-016	021-726-016	021-728-016	021-730-016	Ø 1,6 mm
021-720-018	021-722-018	021-724-018	021-726-018	021-728-018	021-730-018	Ø 1,8 mm
021-720-020	021-722-020	021-724-020	021-726-020	021-728-020	021-730-020	Ø 2,0 mm
021-720-022	021-722-022	021-724-022	021-726-022	021-728-022	021-730-022	Ø 2,2 mm
021-720-025	021-722-025	021-724-025	021-726-025	021-728-025	021-730-025	Ø 2,5 mm
021-720-030	021-722-030	021-724-030	021-726-030	021-728-030	021-730-030	Ø 3,0 mm

- Bohrdrähte mit Trokarspitze und flachem Schaftende, in Packungen zu 10 Stk.
 Wire drills with trocar point and flat shaft end, in packages of 10 pieces
 Aguja con punta trocar y cabo plano, en paquetes de 10 piezas
 Punte trequarti a punta, in confezioni da 10 pezzi



KIRSCHNER

6,0 cm / 2 1/2"	10,0 cm / 4"	12,0 cm / 4 3/4"	14,0 cm / 4 3/4"	16,0 cm / 6 1/4"	31,0 cm / 12 1/4"	
021-740-008	021-742-008	021-744-008	021-746-008	021-748-008	021-750-008	Ø 0,8 mm
021-740-010	021-742-010	021-744-010	021-746-010	021-748-010	021-750-010	Ø 1,0 mm
021-740-012	021-742-012	021-744-012	021-746-012	021-748-012	021-750-012	Ø 1,2 mm
021-740-014	021-742-014	021-744-014	021-746-014	021-748-014	021-750-014	Ø 1,4 mm
021-740-015	021-742-015	021-744-015	021-746-015	021-748-015	021-750-015	Ø 1,5 mm
021-740-016	021-742-016	021-744-016	021-746-016	021-748-016	021-750-016	Ø 1,6 mm
021-740-018	021-742-018	021-744-018	021-746-018	021-748-018	021-750-018	Ø 1,8 mm
021-740-020	021-742-020	021-744-020	021-746-020	021-748-020	021-750-020	Ø 2,0 mm
021-740-022	021-742-022	021-744-022	021-746-022	021-748-022	021-750-022	Ø 2,2 mm
021-740-025	021-742-025	021-744-025	021-746-025	021-748-025	021-750-025	Ø 2,5 mm
021-740-030	021-742-030	021-744-030	021-746-030	021-748-030	021-750-030	Ø 3,0 mm

für Drähte mit
 for wires with
 para agujas con
 per punte con

□



für Drähte mit
 for wires with
 para agujas con
 per punte con

KIRSCHNER

021-762-008	Ø 0,8 mm	10,0 cm / 4"
021-762-010	Ø 1,0 mm	10,0 cm / 4"
021-762-012	Ø 1,2 mm	10,0 cm / 4"
021-762-014	Ø 1,4 mm	10,0 cm / 4"
021-762-015	Ø 1,5 mm	10,0 cm / 4"
021-762-016	Ø 1,6 mm	10,0 cm / 4"
021-762-018	Ø 1,8 mm	10,0 cm / 4"
021-762-020	Ø 2,0 mm	10,0 cm / 4"
021-762-022	Ø 2,2 mm	10,0 cm / 4"
021-762-025	Ø 2,5 mm	10,0 cm / 4"
021-762-030	Ø 3,0 mm	10,0 cm / 4"

- Bohrdraht mit Lanzettenspitze, flaches Schaftende, in Packungen zu 10 Stk.
 Wire drill with lancet point, flat shaft end, in packages of 10 pieces
 Aguja con punta de lancetta, cabo plano, en paquetes de 10 piezas
 Punta lanceolata a punta, in confezioni da 10 pezzi



mit Metall-Deckel
 with metal lid
 con tapa metalica
 con coperchio metallico

für Drähte mit
 for wires with
 para agujas con
 per punte con

mit Kunststoff-Deckel
 with plastic lid
 con tapa de plastico
 con coperchio in plastico

für Drähte mit
 for wires with
 para agujas con
 per punte con

10,0 cm / 4"	16,0 cm / 6 1/4"	31,0 cm / 12 1/4"		10,0 cm / 4"	16,0 cm / 6 1/4"	31,0 cm / 12 1/4"	
021-900-008	021-902-008	021-904-008	Ø 0,8 mm	021-901-008	021-903-008	021-905-008	Ø 0,8 mm
021-900-010	021-902-010	021-904-010	Ø 1,0 mm	021-901-010	021-903-010	021-905-010	Ø 1,0 mm
021-900-012	021-902-012	021-904-012	Ø 1,2 mm	021-901-012	021-903-012	021-905-012	Ø 1,2 mm
021-900-014	021-902-014	021-904-014	Ø 1,4 mm	021-901-014	021-903-014	021-905-014	Ø 1,4 mm
021-900-015	021-902-015	021-904-015	Ø 1,5 mm	021-901-015	021-903-015	021-905-015	Ø 1,5 mm
021-900-016	021-902-016	021-904-016	Ø 1,6 mm	021-901-016	021-903-016	021-905-016	Ø 1,6 mm
021-900-018	021-902-018	021-904-018	Ø 1,8 mm	021-901-018	021-903-018	021-905-018	Ø 1,8 mm
021-900-020	021-902-020	021-904-020	Ø 2,0 mm	021-901-020	021-903-020	021-905-020	Ø 2,0 mm
021-900-022	021-902-022	021-904-022	Ø 2,2 mm	021-901-022	021-903-022	021-905-022	Ø 2,2 mm
021-900-025	021-902-025	021-904-025	Ø 2,5 mm	021-901-025	021-903-025	021-905-025	Ø 2,5 mm
021-900-030	021-902-030	021-904-030	Ø 3,0 mm	021-901-030	021-903-030	021-905-030	Ø 3,0 mm



021

Mehrfach-Bohrdrahtspender
Multiple Wire Drill Dispenser
Dispensador multiple para brocas filiformes
Distributore multiplo per punte filiformi

- Vier verschiedene Bohrdrähte in einem Spender.
- Eindeutige Kennzeichnung der verschiedenen Durchmesser auf dem Spender.
- Sterilisation und Aufbewahrung im Spender.

- Four different wire drills from one dispenser.
- Clear size markings on the dispenser.
- Sterilization and storage in the dispenser.

- Cuatro agujas distintas en un sólo dispensador.
- El dispensador está marcado claramente con los diferentes diámetros.
- Esterilización y almacejaje dentro del mismo dispensador.

- 4 Differenti punte filiformi e un solo contenitore
- Distributore marcato con i vari diametri.
- Sterilizzazione e conservazione nello stesso distributore.



021-916-310 Ø 1,0 / 1,2 / 1,4 / 1,6 mm x 310 mm
021-918-310 Ø 1,8 / 2,0 / 2,2 / 2,5 mm x 310 mm

021-912-160 Ø 1,0 / 1,2 / 1,4 / 1,6 mm x 160 mm
021-914-160 Ø 1,8 / 2,0 / 2,2 / 2,5 mm x 160 mm



021-920-100 für 10,0 cm Draht / for 10,0 cm wire / para agujas de 10,0 cm / per punte filiformi 10,0 cm

021-920-150 für 15,0 cm Draht / for 15,0 cm wire / para agujas de 15,0 cm / per punte filiformi 15,0 cm

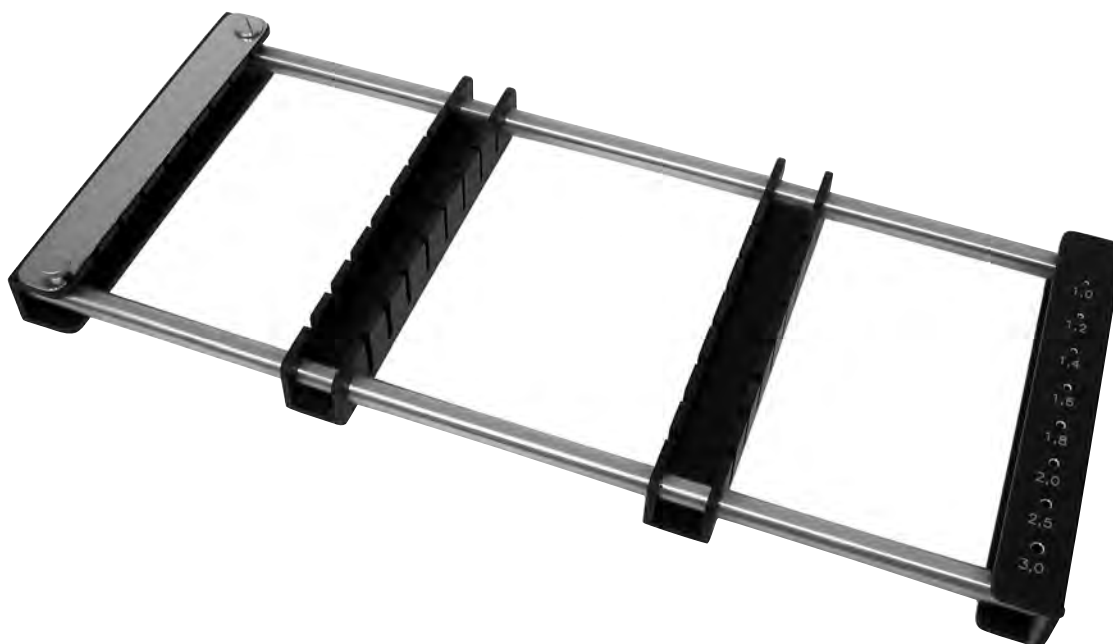

021-922-310 für 31,0 cm Draht / for 31,0 cm wire / para agujas de 31,0 cm / per punte filiformi 31,0 cm



021



024

Knochenchirurgie
Bone Surgery
Cirugía ósea
Chirurgia ossea



024

Flachmeißel, Hohlmeißel, Osteotome
Chiseles, Gouges, Osteotomes
Cinceles, Gubias, Osteótomos
Scalpelli, Sgorbie, Osteotomi



024-010-008	8 mm	13,5 cm / 5 ³ / ₈ "
024-010-010	10 mm	13,5 cm / 5 ³ / ₈ "
024-010-012	12 mm	13,5 cm / 5 ³ / ₈ "
024-010-014	14 mm	13,5 cm / 5 ³ / ₈ "
024-010-016	16 mm	13,5 cm / 5 ³ / ₈ "



024-012-008	8 mm	13,5 cm / 5 ³ / ₈ "
024-012-010	10 mm	13,5 cm / 5 ³ / ₈ "
024-012-012	12 mm	13,5 cm / 5 ³ / ₈ "
024-012-014	14 mm	13,5 cm / 5 ³ / ₈ "
024-012-016	16 mm	13,5 cm / 5 ³ / ₈ "



024-014-008	8 mm	13,5 cm / 5 ³ / ₈ "
024-014-010	10 mm	13,5 cm / 5 ³ / ₈ "
024-014-012	12 mm	13,5 cm / 5 ³ / ₈ "
024-014-014	14 mm	13,5 cm / 5 ³ / ₈ "
024-014-016	16 mm	13,5 cm / 5 ³ / ₈ "



PARTSCH

024-020-002	2 mm	13,5 cm / 5 ³ / ₈ "
024-020-003	3 mm	13,5 cm / 5 ³ / ₈ "
024-020-004	4 mm	13,5 cm / 5 ³ / ₈ "
024-020-005	5 mm	13,5 cm / 5 ³ / ₈ "
024-020-006	6 mm	13,5 cm / 5 ³ / ₈ "



PARTSCH

024-022-002	2 mm	17,0 cm / 6 ³ / ₄ "
024-022-003	3 mm	17,0 cm / 6 ³ / ₄ "
024-022-004	4 mm	17,0 cm / 6 ³ / ₄ "
024-022-005	5 mm	17,0 cm / 6 ³ / ₄ "
024-022-006	6 mm	17,0 cm / 6 ³ / ₄ "
024-022-007	7 mm	17,0 cm / 6 ³ / ₄ "



PARTSCH

024-024-002	2 mm	13,5 cm / 5 ³ / ₈ "
024-024-003	3 mm	13,5 cm / 5 ³ / ₈ "
024-024-004	4 mm	13,5 cm / 5 ³ / ₈ "
024-024-005	5 mm	13,5 cm / 5 ³ / ₈ "
024-024-006	6 mm	13,5 cm / 5 ³ / ₈ "



PARTSCH

024-026-002	2 mm	17,0 cm / 6 ³ / ₄ "
024-026-003	3 mm	17,0 cm / 6 ³ / ₄ "
024-026-004	4 mm	17,0 cm / 6 ³ / ₄ "
024-026-005	5 mm	17,0 cm / 6 ³ / ₄ "
024-026-006	6 mm	17,0 cm / 6 ³ / ₄ "
024-026-007	7 mm	17,0 cm / 6 ³ / ₄ "



ALEXANDER

024-030-004	4 mm	18,0 cm / 7"
024-030-006	6 mm	18,0 cm / 7"
024-030-008	8 mm	18,0 cm / 7"
024-030-010	10 mm	18,0 cm / 7"
024-030-012	12 mm	18,0 cm / 7"
024-030-014	14 mm	18,0 cm / 7"



ALEXANDER

024-032-004	4 mm	18,0 cm / 7"
024-032-006	6 mm	18,0 cm / 7"
024-032-008	8 mm	18,0 cm / 7"
024-032-010	10 mm	18,0 cm / 7"
024-032-012	12 mm	18,0 cm / 7"
024-032-014	14 mm	18,0 cm / 7"



STILLE

024-040-010	10 mm	20,0 cm / 8"
024-040-015	15 mm	20,0 cm / 8"
024-040-020	20 mm	20,0 cm / 8"
024-040-025	25 mm	20,0 cm / 8"



STILLE

024-042-010	10 mm	20,0 cm / 8"
024-042-015	15 mm	20,0 cm / 8"
024-042-020	20 mm	20,0 cm / 8"
024-042-025	25 mm	20,0 cm / 8"



STILLE

024-044-010	10 mm	20,0 cm / 8"
024-044-015	15 mm	20,0 cm / 8"
024-044-020	20 mm	20,0 cm / 8"
024-044-025	25 mm	20,0 cm / 8"



024

Osteotome
Osteotomes
Osteótomos
Osteotomi



MINI-LAMBOTTE

024-050-002	2 mm	12,5 cm / 5"
024-050-003	3 mm	12,5 cm / 5"
024-050-004	4 mm	12,5 cm / 5"
024-050-006	6 mm	12,5 cm / 5"
024-050-008	8 mm	12,5 cm / 5"
024-050-010	10 mm	12,5 cm / 5"
024-050-012	12 mm	12,5 cm / 5"
024-050-015	15 mm	12,5 cm / 5"



MINI-LAMBOTTE

024-052-003	3 mm	17,0 cm / 6 ³ / ₄ "
024-052-004	4 mm	17,0 cm / 6 ³ / ₄ "
024-052-006	6 mm	17,0 cm / 6 ³ / ₄ "
024-052-008	8 mm	17,0 cm / 6 ³ / ₄ "
024-052-010	10 mm	17,0 cm / 6 ³ / ₄ "
024-052-012	12 mm	17,0 cm / 6 ³ / ₄ "
024-052-015	15 mm	17,0 cm / 6 ³ / ₄ "



LAMBOTTE

024-054-004	4 mm	24,0 cm / 9 ¹ / ₂ "
024-054-006	6 mm	24,0 cm / 9 ¹ / ₂ "
024-054-008	8 mm	24,0 cm / 9 ¹ / ₂ "
024-054-010	10 mm	24,0 cm / 9 ¹ / ₂ "
024-054-012	12 mm	24,0 cm / 9 ¹ / ₂ "
024-054-015	15 mm	24,0 cm / 9 ¹ / ₂ "
024-054-020	20 mm	24,0 cm / 9 ¹ / ₂ "
024-054-025	25 mm	24,0 cm / 9 ¹ / ₂ "
024-054-030	30 mm	24,0 cm / 9 ¹ / ₂ "
024-054-038	38 mm	24,0 cm / 9 ¹ / ₂ "
024-054-044	44 mm	24,0 cm / 9 ¹ / ₂ "
024-054-050	50 mm	24,0 cm / 9 ¹ / ₂ "



LAMBOTTE

024-056-004	4 mm	24,0 cm / 9 ¹ / ₂ "
024-056-006	6 mm	24,0 cm / 9 ¹ / ₂ "
024-056-008	8 mm	24,0 cm / 9 ¹ / ₂ "
024-056-010	10 mm	24,0 cm / 9 ¹ / ₂ "
024-056-012	12 mm	24,0 cm / 9 ¹ / ₂ "
024-056-015	15 mm	24,0 cm / 9 ¹ / ₂ "
024-056-020	20 mm	24,0 cm / 9 ¹ / ₂ "
024-056-025	25 mm	24,0 cm / 9 ¹ / ₂ "
024-056-030	30 mm	24,0 cm / 9 ¹ / ₂ "
024-056-038	38 mm	24,0 cm / 9 ¹ / ₂ "
024-056-044	44 mm	24,0 cm / 9 ¹ / ₂ "
024-056-050	50 mm	24,0 cm / 9 ¹ / ₂ "



SMITH-PETERSON

024-060-006	6 mm	20,0 cm / 8"
024-060-009	9 mm	20,0 cm / 8"
024-060-013	13 mm	20,0 cm / 8"
024-060-016	16 mm	20,0 cm / 8"
024-060-019	19 mm	20,0 cm / 8"
024-060-025	25 mm	20,0 cm / 8"
024-060-032	32 mm	20,0 cm / 8"



SMITH-PETERSON

024-061-006	6 mm	20,0 cm / 8"
024-061-009	9 mm	20,0 cm / 8"
024-061-013	13 mm	20,0 cm / 8"
024-061-016	16 mm	20,0 cm / 8"
024-061-019	19 mm	20,0 cm / 8"
024-061-025	25 mm	20,0 cm / 8"
024-061-032	32 mm	20,0 cm / 8"



SMITH-PETERSON

024-064-009	9 mm	20,0 cm / 8"
024-064-014	14 mm	20,0 cm / 8"
024-064-019	19 mm	20,0 cm / 8"
024-064-025	25 mm	20,0 cm / 8"



SMITH-PETERSON

024-065-009	9 mm	20,0 cm / 8"
024-065-014	14 mm	20,0 cm / 8"
024-065-019	19 mm	20,0 cm / 8"
024-065-025	25 mm	20,0 cm / 8"



024

Flachmeißel, Hohlmeißel, Osteotome
Chiseles, Gouges, Osteotomes
Cinceles, Gubias, Osteótomos
Scalpelli, SGorbie, Osteotomi



HOKE

024-068-003	3 mm	17,0 cm / 6 ³ / ₄ "
024-068-005	5 mm	17,0 cm / 6 ³ / ₄ "
024-068-006	6 mm	17,0 cm / 6 ³ / ₄ "
024-068-008	8 mm	17,0 cm / 6 ³ / ₄ "
024-068-009	9 mm	17,0 cm / 6 ³ / ₄ "



HIBBS

024-070-006	6 mm	24,0 cm / 9 ¹ / ₂ "
024-070-013	13 mm	24,0 cm / 9 ¹ / ₂ "
024-070-019	19 mm	24,0 cm / 9 ¹ / ₂ "
024-070-025	25 mm	24,0 cm / 9 ¹ / ₂ "
024-070-032	32 mm	24,0 cm / 9 ¹ / ₂ "



HIBBS

024-072-006	6 mm	24,0 cm / 9½"
024-072-013	13 mm	24,0 cm / 9½"
024-072-019	19 mm	24,0 cm / 9½"
024-072-025	25 mm	24,0 cm / 9½"
024-072-032	32 mm	24,0 cm / 9½"



HIBBS

024-073-006	6 mm	24,0 cm / 9½"
024-073-013	13 mm	24,0 cm / 9½"
024-073-019	19 mm	24,0 cm / 9½"
024-073-025	25 mm	24,0 cm / 9½"
024-073-032	32 mm	24,0 cm / 9½"



HIBBS

024-076-006	6 mm	24,0 cm / 9½"
024-076-013	13 mm	24,0 cm / 9½"
024-076-019	19 mm	24,0 cm / 9½"
024-076-025	25 mm	24,0 cm / 9½"
024-076-032	32 mm	24,0 cm / 9½"



HIBBS

024-077-006	6 mm	24,0 cm / 9½"
024-077-013	13 mm	24,0 cm / 9½"
024-077-019	19 mm	24,0 cm / 9½"
024-077-025	25 mm	24,0 cm / 9½"
024-077-032	32 mm	24,0 cm / 9½"



024

Stößel
Tampers
Pisón
Punzoni



#

024-080-002 ø 2 mm



024-080-003 ø 3 mm



024-080-004 ø 4 mm



024-080-005 ø 5 mm



024-080-006 ø 6 mm



024-080-008 ø 8 mm



024-080-010 ø 10 mm

024-080-002 - 024-080-010 15,5 cm / 6"



#

024-090-003 ø 3 mm



024-090-005 ø 5 mm



024-090-008 ø 8 mm



024-090-012 ø 12 mm

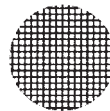

024-090-014 ø 14 mm

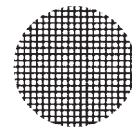

024-090-016 ø 16 mm

024-090-003 - 024-090-016 20,0 cm / 8"



024-100-180 18,0 cm / 7"



024-108-001

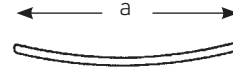

Hohlmeißel
 Gouges
 Gubias
 Sgorbie

024-102-050 a = 50 mm
024-102-060 a = 60 mm
024-102-070 a = 70 mm

Flachmeißel
 Chisels
 Cinceles
 Scalpelli

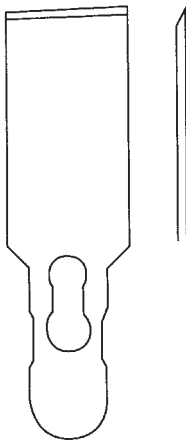

024-104-005 5,0 mm
024-104-010 10,0 mm
024-104-016 16,0 mm
024-104-025 25,0 mm

Osteotome
 Chisels
 Cinceles
 Scalpelli

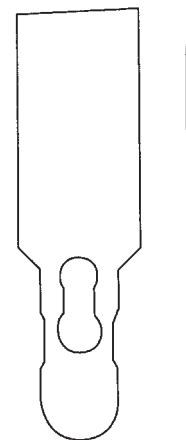

024-106-005 5,0 mm
024-106-010 10,0 mm
024-106-016 16,0 mm
024-106-025 25,0 mm



024

Flachmeißel, Hohlmeißel und Osteotome mit Ferrozellgriff
Chisels, Gouges and Osteotomes with handle from artificial wood
Cinceles, Gubias y Osteótomos con mango de madera artificial
Scalpelli, Sgorbie e Osteotomi con manico in legno artificiale



Osteotome
Chisels
Cinceles
Scalpelli

MINI-LEXER

024-110-004	4 mm	18,0 cm / 7"
024-110-006	6 mm	18,0 cm / 7"
024-110-008	8 mm	18,0 cm / 7"
024-110-010	10 mm	18,0 cm / 7"
024-110-012	12 mm	18,0 cm / 7"



Hohlmeißel
Gouges
Gubias
Sgorbie

MINI-LEXER

024-112-004	4 mm	18,0 cm / 7"
024-112-006	6 mm	18,0 cm / 7"
024-112-008	8 mm	18,0 cm / 7"
024-112-010	10 mm	18,0 cm / 7"
024-112-012	12 mm	18,0 cm / 7"



Hohlmeißel
Gouges
Gubias
Sgorbie

LEXER

024-114-005	5 mm	25,0 cm / 9 ³ / ₄ "
024-114-010	10 mm	25,0 cm / 9 ³ / ₄ "
024-114-015	15 mm	25,0 cm / 9 ³ / ₄ "



Hohlmeißel
Gouges
Gubias
Sgorbie

LEXER

024-115-005	5 mm	25,0 cm / 9 ³ / ₄ "
024-115-010	10 mm	25,0 cm / 9 ³ / ₄ "
024-115-015	15 mm	25,0 cm / 9 ³ / ₄ "



Osteotome
 Chisels
 Cinceles
 Scalpelli

LEXER

024-116-005	5 mm	22,0 cm / 8 ³ / ₄ "
024-116-007	7 mm	22,0 cm / 8 ³ / ₄ "
024-116-010	10 mm	22,0 cm / 8 ³ / ₄ "
024-116-015	15 mm	22,0 cm / 8 ³ / ₄ "
024-116-020	20 mm	22,0 cm / 8 ³ / ₄ "
024-116-025	25 mm	22,0 cm / 8 ³ / ₄ "
024-116-030	30 mm	22,0 cm / 8 ³ / ₄ "



Hohlmeißel
 Gouges
 Gubias
 Sgorbie

LEXER

024-118-005	5 mm	22,0 cm / 8 ³ / ₄ "
024-118-007	7 mm	22,0 cm / 8 ³ / ₄ "
024-118-010	10 mm	22,0 cm / 8 ³ / ₄ "
024-118-015	15 mm	22,0 cm / 8 ³ / ₄ "
024-118-020	20 mm	22,0 cm / 8 ³ / ₄ "
024-118-025	25 mm	22,0 cm / 8 ³ / ₄ "
024-118-030	30 mm	22,0 cm / 8 ³ / ₄ "



Osteotome
 Chisels
 Cinceles
 Scalpelli

LEXER

024-123-010	10 mm	27,5 cm / 10 ³ / ₄ "
024-123-015	15 mm	27,5 cm / 10 ³ / ₄ "



024

Flachmeißel, Hohlmeißel und Osteotome mit Ferrozellgriff
Chisels, Gouges and Osteotomes with handle from artificial wood
Cinceles, Gubias y Osteótomos con mango de madera artificial
Scalpelli, Sgorbie e Osteotomi con manico in legno artificiale



Hohlmeißel
Gouges
Gubias
Sgorbie

LEXER

024-125-010	10 mm	27,5 cm / 10 ³ / ₄ "
024-125-015	15 mm	27,5 cm / 10 ³ / ₄ "



Hohlmeißel
Gouges
Gubias
Sgorbie

ZIELKE

024-127-005	5,5 mm	23,0 cm / 9"
024-127-009	9,0 mm	23,0 cm / 9"



Flachmeißel
Chisels
Cinceles
Scalpelli

024-130-010	10 mm	16,0 cm / 6 ¹ / ₄ "
024-130-015	15 mm	16,0 cm / 6 ¹ / ₄ "



Flachmeißel
Chisels
Cinceles
Scalpelli

024-132-010	10 mm	20,0 cm / 8"
024-132-015	15 mm	20,0 cm / 8"
024-132-020	20 mm	20,0 cm / 8"



Flachmeißel
 Chisels
 Cinceles
 Scalpelli

024-133-010 10,0 mm 20,0 cm / 8"
024-133-015 15,0 mm 20,0 cm / 8"
024-133-020 20,0 mm 20,0 cm / 8"



Flachmeißel
 Chisels
 Cinceles
 Scalpelli

024-136-020 20,0 mm 24,5 cm / 9³/₄"



Flachmeißel
 Chisels
 Cinceles
 Scalpelli

024-137-016 16,0 mm 26,5 cm / 10¹/₂"



Hohlmeißel
 Gouges
 Gubias
 Sgorbie

024-140-220 9,0 mm 22,0 cm / 8³/₄"



024

Flachmeißel, Hohlmeißel und Osteotome mit Ferrozellgriff
Chisels, Gouges and Osteotomes with handle from artificial wood
Cinceles, Gubias y Osteótomos con mango de madera artificial
Scalpelli, Sgorbie e Osteotomi con manico in legno artificiale



Hohlmeißel
Gouge
Gubia
Sgorbie

COBB

024-142-275 8,0 mm 27,5 cm / 10³/₄"



Hohlmeißel
Gouge
Gubia
Sgorbie

COBB

024-143-270 8,0 mm 27,0 cm / 10³/₄"



Hohlmeißel
Gouge
Gubia
Sgorbie

COBB

024-145-270 8,0 mm 27,0 cm / 10³/₄"



DAHMEN

024-150-004	4 mm	30,0 cm / 11 ³ / ₄ "
024-150-005	5 mm	30,0 cm / 11 ³ / ₄ "
024-150-006	6 mm	30,0 cm / 11 ³ / ₄ "
024-150-008	8 mm	30,0 cm / 11 ³ / ₄ "
024-150-010	10 mm	30,0 cm / 11 ³ / ₄ "
024-150-012	12 mm	30,0 cm / 11 ³ / ₄ "
024-150-015	15 mm	30,0 cm / 11 ³ / ₄ "
024-150-020	20 mm	30,0 cm / 11 ³ / ₄ "
024-150-022	22 mm	30,0 cm / 11 ³ / ₄ "
024-150-025	25 mm	30,0 cm / 11 ³ / ₄ "



DAHMEN

024-154-004	4 mm	30,0 cm / 11 ³ / ₄ "
024-154-005	5 mm	30,0 cm / 11 ³ / ₄ "
024-154-006	6 mm	30,0 cm / 11 ³ / ₄ "
024-154-008	8 mm	30,0 cm / 11 ³ / ₄ "
024-154-010	10 mm	30,0 cm / 11 ³ / ₄ "
024-154-012	12 mm	30,0 cm / 11 ³ / ₄ "
024-154-015	15 mm	30,0 cm / 11 ³ / ₄ "
024-154-020	20 mm	30,0 cm / 11 ³ / ₄ "
024-154-022	22 mm	30,0 cm / 11 ³ / ₄ "
024-154-025	25 mm	30,0 cm / 11 ³ / ₄ "



024

Flachmeißel und Hohlmeißel mit Ferrozellgriff
Chisels and Gouges with handle from artificial wood
Cinceles y Gubias con mango de madera artificial
Scalpellì e Sgorbie con manico in legno artificiale



DAHMEN

024-155-004	4 mm	30,0 cm / 11 ³ / ₄ "
024-155-005	5 mm	30,0 cm / 11 ³ / ₄ "
024-155-006	6 mm	30,0 cm / 11 ³ / ₄ "
024-155-008	8 mm	30,0 cm / 11 ³ / ₄ "
024-155-010	10 mm	30,0 cm / 11 ³ / ₄ "
024-155-012	12 mm	30,0 cm / 11 ³ / ₄ "
024-155-015	15 mm	30,0 cm / 11 ³ / ₄ "
024-155-020	20 mm	30,0 cm / 11 ³ / ₄ "
024-155-022	22 mm	30,0 cm / 11 ³ / ₄ "
024-155-025	25 mm	30,0 cm / 11 ³ / ₄ "



DAHMEN

024-159-004	4 mm	30,0 cm / 11 ³ / ₄ "
024-159-005	5 mm	30,0 cm / 11 ³ / ₄ "
024-159-006	6 mm	30,0 cm / 11 ³ / ₄ "
024-159-008	8 mm	30,0 cm / 11 ³ / ₄ "
024-159-010	10 mm	30,0 cm / 11 ³ / ₄ "
024-159-012	12 mm	30,0 cm / 11 ³ / ₄ "
024-159-015	15 mm	30,0 cm / 11 ³ / ₄ "
024-159-020	20 mm	30,0 cm / 11 ³ / ₄ "
024-159-022	22 mm	30,0 cm / 11 ³ / ₄ "
024-159-025	25 mm	30,0 cm / 11 ³ / ₄ "



WILLIGER

024-200-300	300 g	ø 26 mm	24,0 cm / 9 ¹ / ₂ "
024-200-340	340 g	ø 28 mm	24,0 cm / 9 ¹ / ₂ "
024-200-400	400 g	ø 30 mm	24,0 cm / 9 ¹ / ₂ "



DOYEN

024-202-120	120 g	ø 25 mm	19,5 cm / 7 ³ / ₄ "
024-202-180	180 g	ø 30 mm	19,5 cm / 7 ³ / ₄ "
024-202-260	260 g	ø 35 mm	21,0 cm / 8 ¹ / ₄ "



024

Hammer
Mallets
Martillos
Martelli



COLLIN

024-204-220 220 g ø 30 mm 20,0 cm / 8"



LUCAE

024-206-230 230 g ø 19 mm 19,5 cm / 7³/₄"
024-206-260 260 g ø 25 mm 19,5 cm / 7³/₄"



COTTLE

024-208-350 350 g ø 30 mm 19,0 cm / 7½"



WILLIGER

024-210-140 140 g ø 20 mm 16,5 cm / 6½"



mit auswechsel-
baren Backen
(**024-214-001**)
with inter-
changeable disks
(**024-214-001**)
con tapas
intercambiables
(**024-214-001**)
con piastre
intercambiabili
(**024-214-001**)

MEAD

024-212-320 320 g ø 26 mm 19,0 cm / 7½"



PARTSCH

024-216-200 200 g ø 22 mm 19,0 cm / 7½"



024

Hammer
Mallets
Martillos
Martelli



HAJEK

024-218-200 200 g ø 27 mm 20,0 cm / 8"



GERZOG

024-220-270 270 g ø 25 mm 19,5 cm / 7 1/2"



KIRK

024-222-650 650 g ø 38 mm 21,0 cm / 8 1/4"



BERGMANN

024-224-490 490 g ø 45 mm 25,0 cm / 9 3/4"



BERGMANN

024-226-400 400 g ø 30 mm 24,5 cm / 9²/₃"



OMBREDANNE

024-228-700 700 g ø 40 mm 24,0 cm / 9¹/₂"



HEATH

024-230-700 700 g ø 40 mm 18,5 cm / 7¹/₄"

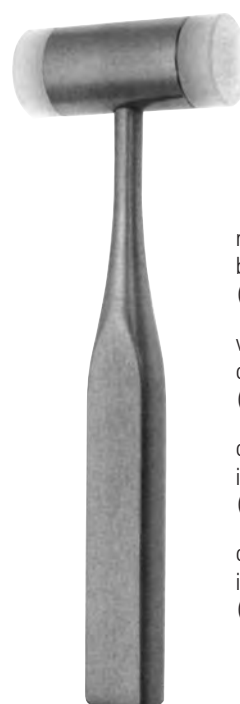

mit auswechsel-
baren Backen
(**024-233-001**)

with inter-
changeable disks
(**024-233-001**)

con tapas
intercambiables
(**024-233-001**)

con piastre
intercambiabili
(**024-233-001**)

024-232-240 240 g ø 25 mm 18,5 cm / 7¹/₄"



024

Hammer
Mallets
Martillos
Martelli



aus Ferrozell
from artificial wood
de madera artificial
in legno artificiale



KIRK

024-234-180	180 g	ø 35 mm	26,0 cm / 10 ¹ / ₄ "
024-234-250	250 g	ø 42 mm	26,0 cm / 10 ¹ / ₄ "
024-234-350	350 g	ø 50 mm	26,0 cm / 10 ¹ / ₄ "

024-236-340	340 g	ø 42 mm	26,0 cm / 10 ¹ / ₄ "
--------------------	-------	---------	--



024-238-675	675 g	ø 30 mm	26,5 cm / 10 ¹ / ₂ "
--------------------	-------	---------	--



024-240-530	530 g	ø 42/30 mm	26,0 cm / 10 ¹ / ₄ "
--------------------	-------	------------	--



024-242-480 480 g ø 30 mm 24,0 cm / 9 1/2"



024-245-001

Ersatzbacken (Paar) Kunststoff
Spare Facings (pair) plastic
Tapas de repuesto (par) plástico
Placche di ricambio (paio) plastica

024-244-370 370 g ø 37 mm 24,0 cm / 9 1/2"



024-246-450 450 g ø 30 mm 26,5 cm / 10 1/2"



024-246-900 900 g ø 50 mm 26,5 cm / 10 1/2"



024

Scharfe Löffel
Bone Currettes
Cucharillas cortantes
Curette per ossa



VOLKMANN

024-300-001 - 024-300-040



Fig. 0000

024-300-040



Fig. 000

024-300-030



Fig. 00

024-300-020



Fig. 0

024-300-010



Fig. 1

024-300-001



Fig. 2

024-300-002



Fig. 3

024-300-003



Fig. 4

024-300-004



Fig. 5

024-300-005



Fig. 6

024-300-006

17,5 cm / 7"



VOLKMANN

024-302-001 - 024-302-040



Fig. 0000

024-302-040



Fig. 000

024-302-030



Fig. 00

024-302-020



Fig. 0

024-302-010



Fig. 1

024-302-001



Fig. 2

024-302-002



Fig. 3

024-302-003



Fig. 4

024-302-004



Fig. 5

024-302-005



Fig. 6

024-302-006

28,0 cm / 11"



Fig. 000
 024-304-030

Fig. 00
 024-304-020

Fig. 0
 024-304-010

Fig. 1
 024-304-001

Fig. 2
 024-304-002

Fig. 3
 024-304-003

Fig. 4
 024-304-004

SCHUDE

024-304-001 - 024-304-030 17,0 cm / 6³/₄"



Fig. 0000
 024-306-040

Fig. 000
 024-306-030

Fig. 00
 024-306-020

Fig. 0
 024-306-010

Fig. 1
 024-306-001

Fig. 2
 024-306-002

Fig. 3
 024-306-003

Fig. 4
 024-306-004

Fig. 5
 024-306-005

Fig. 6
 024-306-006

VOLKMANN

024-306-001 - 024-306-040 17,0 cm / 6³/₄"



024

Scharfe Löffel
Bone Currettes
Cucharillas cortantes
Curette per ossa



Fig. 0000
024-308-040

Fig. 000
024-308-030

Fig. 00
024-308-020

Fig. 0
024-308-010

Fig. 1
024-308-001

Fig. 2
024-308-002

Fig. 3
024-308-003

Fig. 4
024-308-004

Fig. 5
024-308-005

Fig. 6
024-308-006

BRUNS

024-308-001 - 024-308-040 17,0 cm / 6³/₄"



Fig. 000
024-310-030

Fig. 00
024-310-020

Fig. 0
024-310-010

Fig. 1
024-310-001

Fig. 2
024-310-002

Fig. 3
024-310-003

Fig. 4
024-310-004

Fig. 5
024-310-005

SPRATT

024-310-001 - 024-310-030 17,0 cm / 6³/₄"



Fig. 000
 024-312-030

Fig. 00
 024-312-020

Fig. 0
 024-312-010

Fig. 1
 024-312-001

Fig. 2
 024-312-002

Fig. 3
 024-312-003

Fig. 4
 024-312-004

Fig. 5
 024-312-005

Fig. 6
 024-312-006

BRUNS

024-312-001 - 024-312-030 23,0 cm / 9"



SCOVILLE
 024-314-250 25,0 cm / 9³/₄"



SCOVILLE
 024-315-250 25,0 cm / 9³/₄"



SCOVILLE
 024-317-250 25,0 cm / 9³/₄"



024

Scharfe Löffel
Bone Curettes
Cucharillas cortantes
Curette per ossa

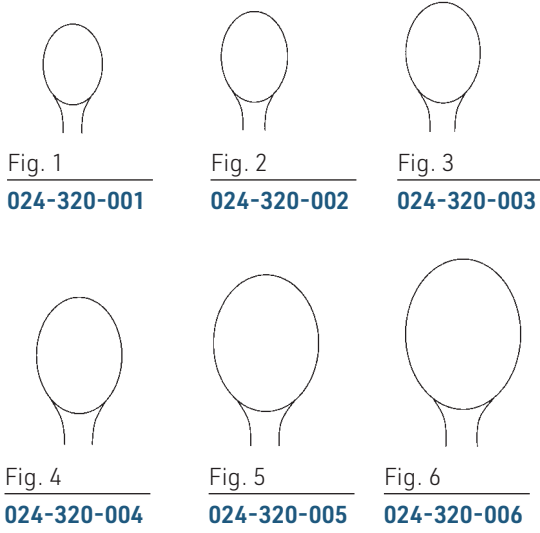

Fig. 1
024-320-001

Fig. 2
024-320-002

Fig. 3
024-320-003

Fig. 4
024-320-004

Fig. 5
024-320-005

Fig. 6
024-320-006

SIMON

024-320-001 - 024-320-006 25,0 cm / 9³/₄"

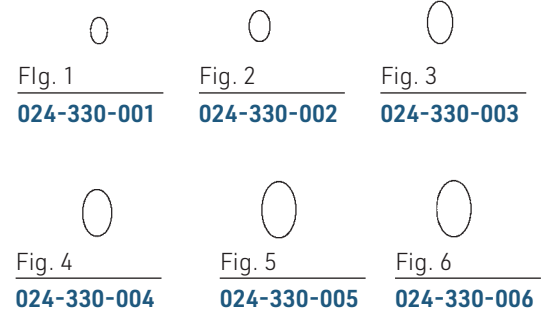

Fig. 1
024-330-001

Fig. 2
024-330-002

Fig. 3
024-330-003

Fig. 4
024-330-004

Fig. 5
024-330-005

Fig. 6
024-330-006

MOD. USA

024-330-001 - 024-330-006 16,0 cm / 6¹/₄"

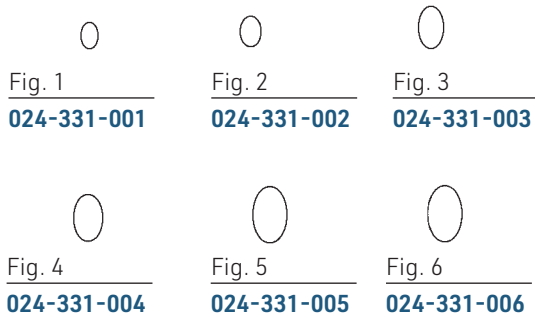

Fig. 1
024-331-001

Fig. 2
024-331-002

Fig. 3
024-331-003

Fig. 4
024-331-004

Fig. 5
024-331-005

Fig. 6
024-331-006

MOD. USA

024-331-001 - 024-331-006 15,5 cm / 6"

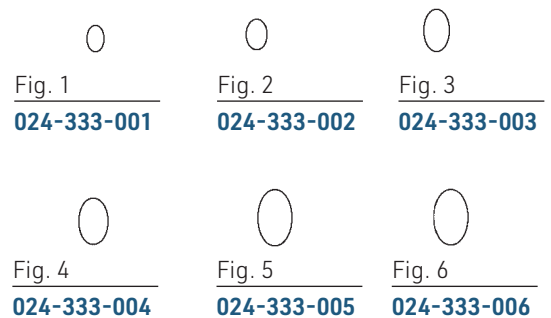

Fig. 1
024-333-001

Fig. 2
024-333-002

Fig. 3
024-333-003

Fig. 4
024-333-004

Fig. 5
024-333-005

Fig. 6
024-333-006

MOD. USA

024-333-001 - 024-333-006 15,5 cm / 6"

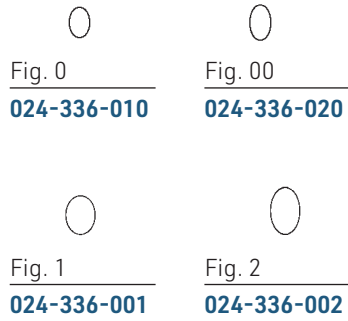

WILLIGER

024-336-001 - 024-336-020 17,0 cm / 6³/₄"

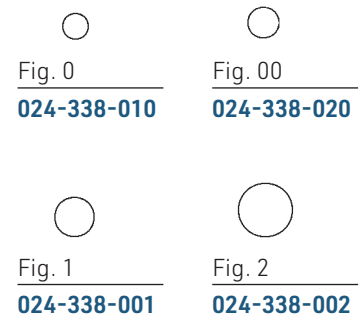

WILLIGER

024-338-001 - 024-338-020 17,5 cm / 7"

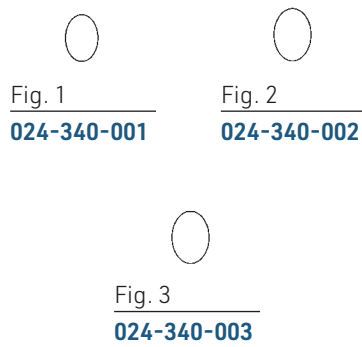

HALLE

024-340-001 - 024-340-003 21,0 cm / 8¹/₄"



024

Scharfe Löffel
Bone Currettes
Cucharillas cortantes
Curette per ossa



024-342-130



024-342-140



024-342-170

VOLKMANN

- 024-342-130 13,0 cm / 5"
- 024-342-140 14,0 cm / 5 1/2"
- 024-342-170 17,0 cm / 6 3/4"



024-344-130



024-344-160



024-344-200



024-346-210 21,0 cm / 8 1/4"

VOLKMANN

- 024-344-130 13,0 cm / 5"
- 024-344-160 16,0 cm / 6 1/4"
- 024-344-200 20,0 cm / 8"



○
 ○
 Fig. 00/0
024-348-000

○
 ○
 Fig. 0/1
024-348-010

○
 ○
 Fig. 1/2
024-348-012

WILLIGER

024-348-000 - 024-348-012 13,5 cm / 5 1/4"



○
 ○
 Fig. 00/00
024-350-000

○
 ○
 Fig. 0/1
024-350-010

○
 ○
 Fig. 1/1
024-350-012

WILLIGER

024-350-000 - 024-350-012 16,0 cm / 6 1/4"



○
 ○
 Fig. 00/0
024-352-000

○
 ○
 Fig. 0/1
024-352-010

○
 ○
 Fig. 1/2
024-352-012

MARTINI

024-352-000 - 024-352-012 13,5 cm / 5 1/4"



Fig. 1 R/L
024-360-001

Fig. 2 R/L
024-360-002

Fig. 3 R/L
024-360-003



HEMMINGWAY

024-360-001 - 024-360-003 18,0 cm / 7"



024

Scharfe Löffel
Bone Currettes
Cucharillas cortantes
Curette per ossa

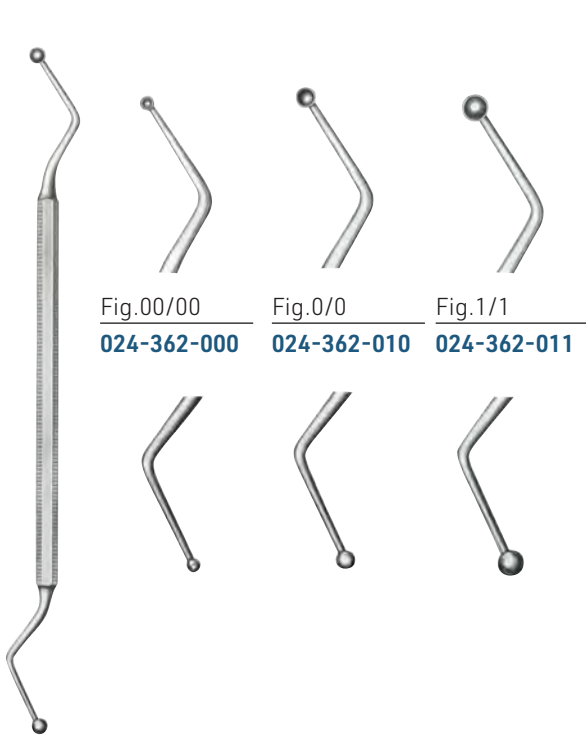

Fig.00/00
024-362-000

Fig.0/0
024-362-010

Fig.1/1
024-362-011

HEMMINGWAY

024-362-000 - 024-362-011 18,0 cm / 7"

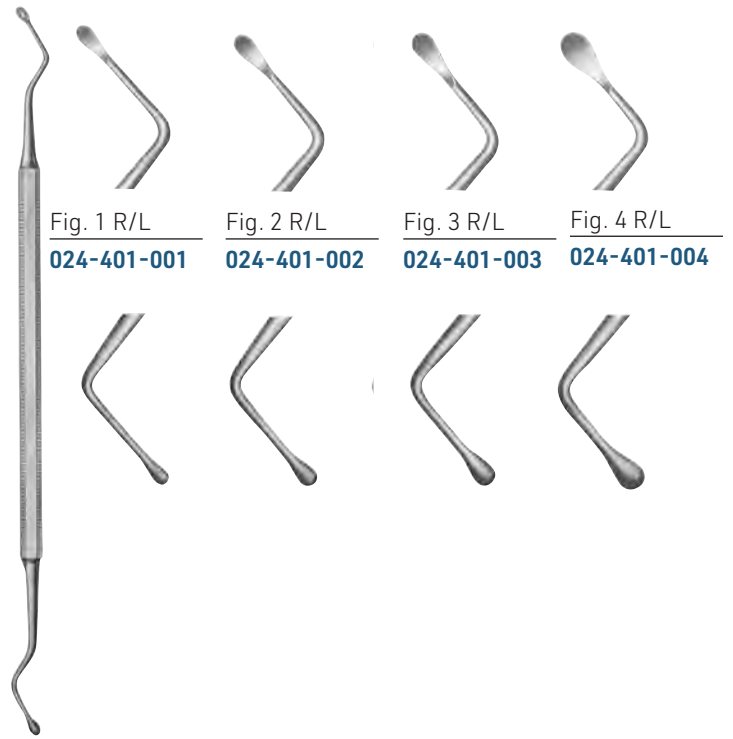

Fig. 1 R/L
024-401-001

Fig. 2 R/L
024-401-002

Fig. 3 R/L
024-401-003

Fig. 4 R/L
024-401-004

HEMMINGWAY

024-401-001 - 024-401-004 18,0 cm / 7"

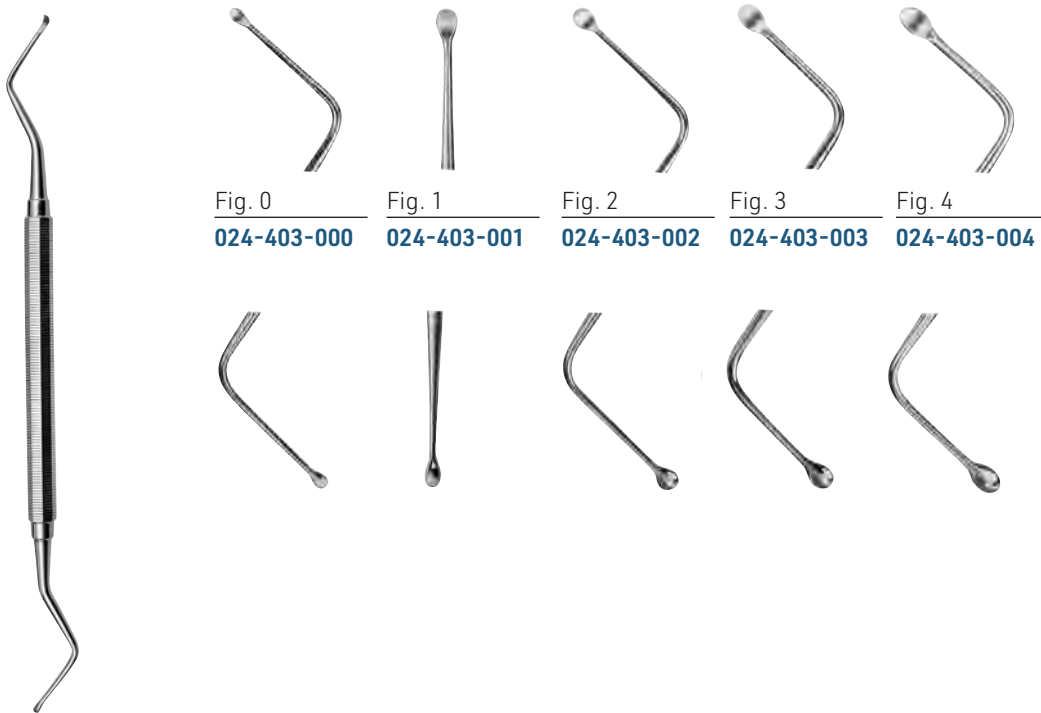

Fig. 0
024-403-000

Fig. 1
024-403-001

Fig. 2
024-403-002

Fig. 3
024-403-003

Fig. 4
024-403-004

MILLER-COLBURN

024-403-000 - 024-403-004 17,0 cm / 6³/₄"



024-406-200 20,0 cm / 8"



024-407-190 19,0 cm / 7 1/2"

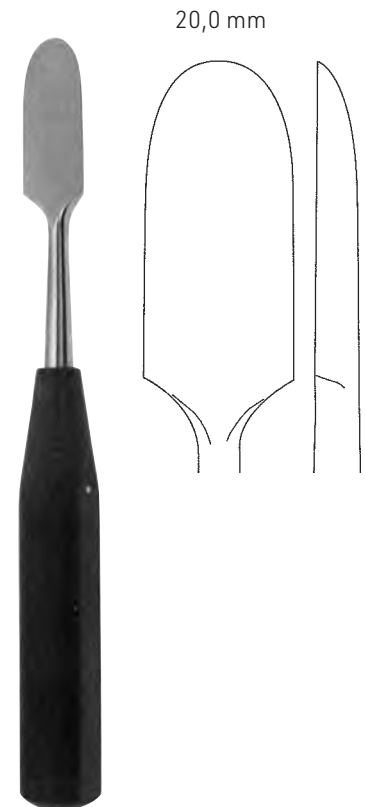

024-408-200 20,0 cm / 8"



024-409-190 19,0 cm / 7 1/2"



024-410-180 18,0 cm / 7"



024-411-180 18,0 cm / 7"



024

Raspatorien mit Ferrozellgriff
Raspatories with handle from artificial wood
Periostótomos con mango de madera artificial
Periostotomi con manico in legno artificiale



024-413-180 18,0 cm / 7"



024-415-180 18,0 cm / 7"

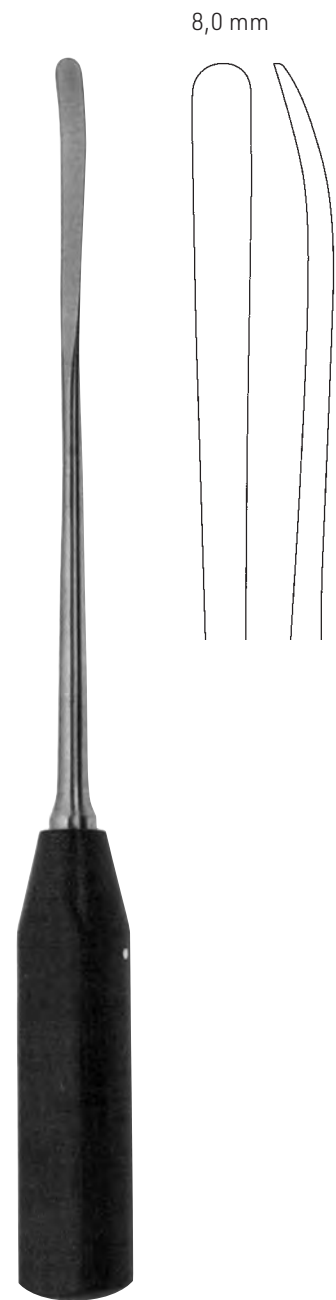

WAGNER
024-417-008 33,0 cm / 13"

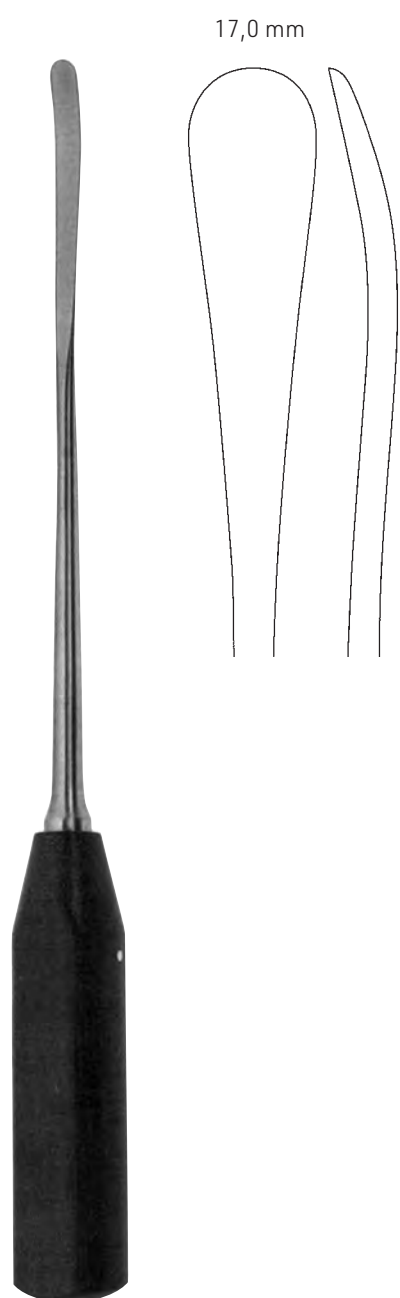

WAGNER

024-417-017 33,0 cm / 13"

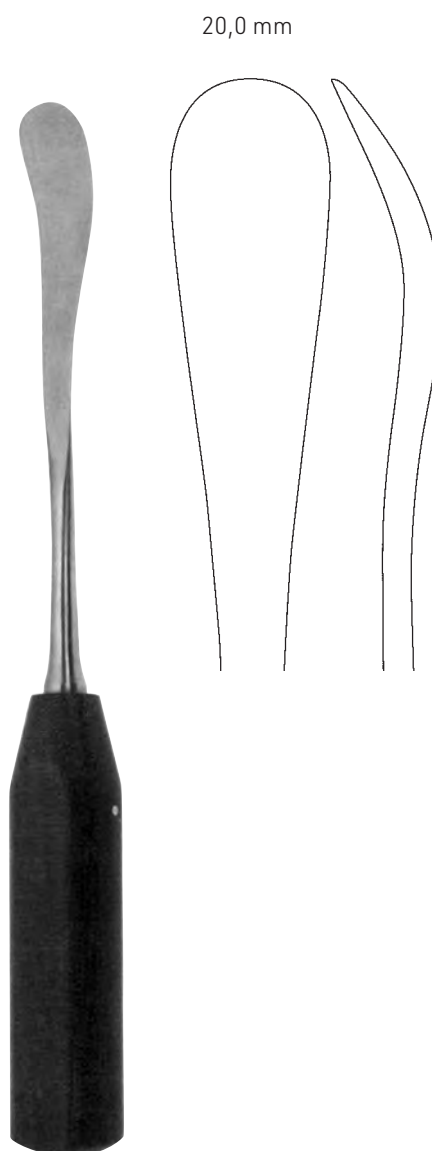

024-419-275 27,5 cm / 10³/₄"



024

Raspatorien
Raspatories
Periostótomos
Periostotomi



024-421-010 10,0 mm



024-425-010 10,0 mm

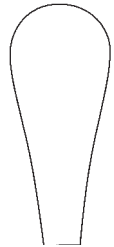

024-421-013 13,0 mm

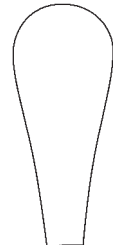

024-425-013 13,0 mm

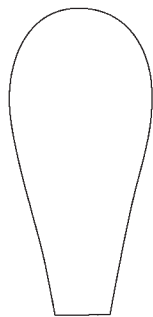

024-421-019 19,0 mm

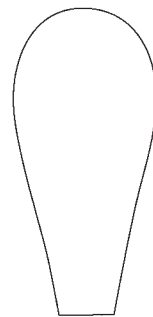

024-425-019 19,0 mm

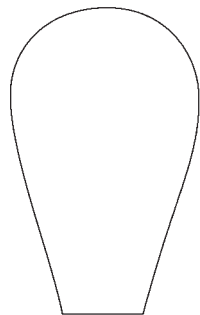

024-421-025 25,0 mm

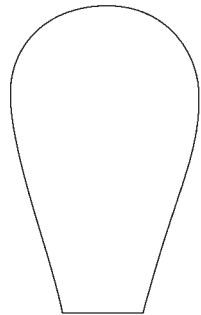

024-425-025 25,0 mm



COBB

024-421-010 - 024-421-025 25,0 cm / 10"



COBB

024-425-010 - 024-425-025 28,0 cm / 11"

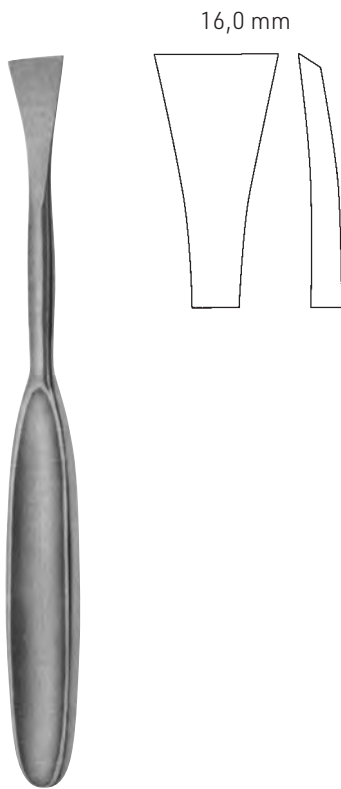

LANGENBECK
024-427-190 19,0 cm / 7½"

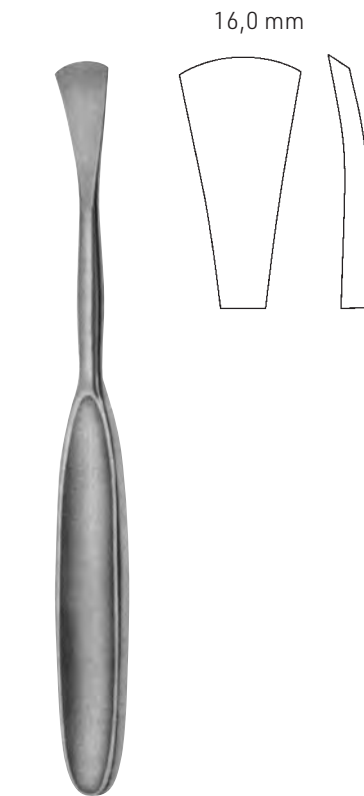

LANGENBECK
024-429-190 19,0 cm / 7½"

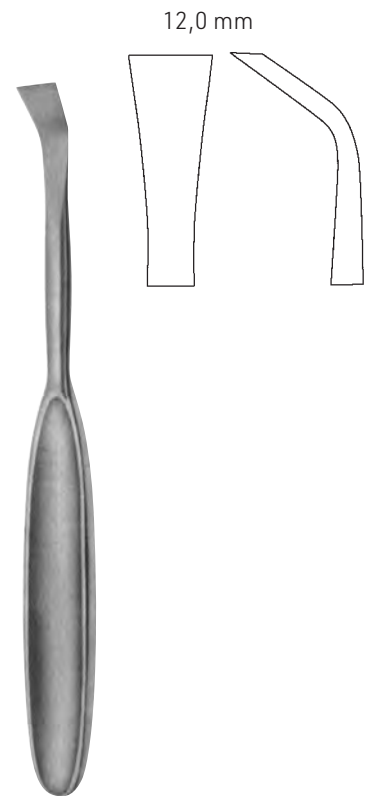

LANGENBECK
024-431-185 18,5 cm / 7¼"

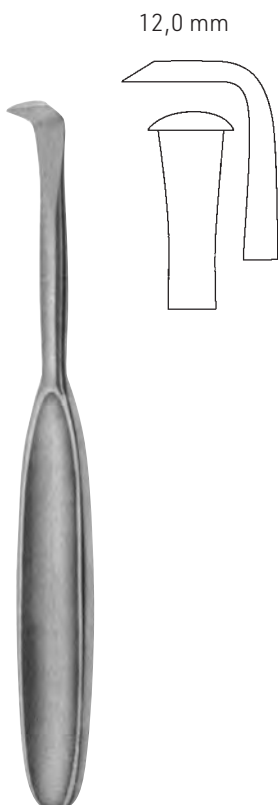

LANGENBECK
024-433-180 18,0 cm / 7"

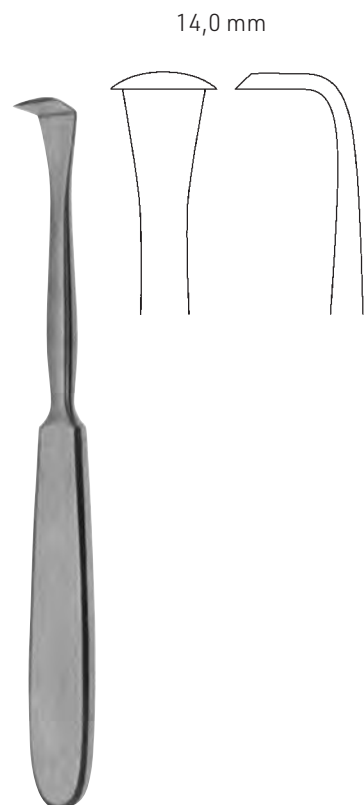

LANGENBECK
024-435-180 18,0 cm / 7"

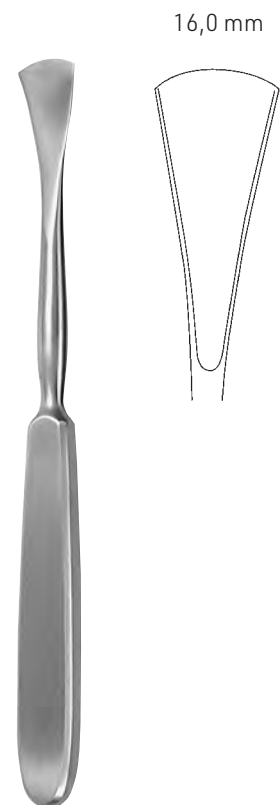

LANGENBECK
024-437-190 19,0 cm / 7½"



024

Raspatorien
Raspatories
Periostótomos
Periostotomi

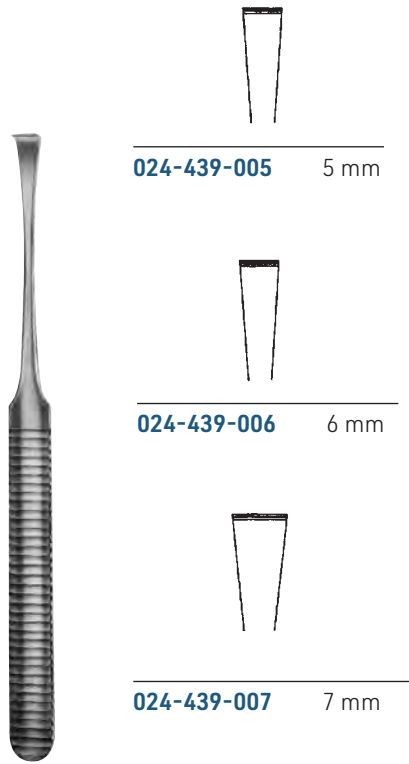

024-439-005 - 024-439-007 16,0 cm / 6 1/4"

12,5 mm



FARABEUF

024-440-150 15,0 cm / 6"

12,5 mm

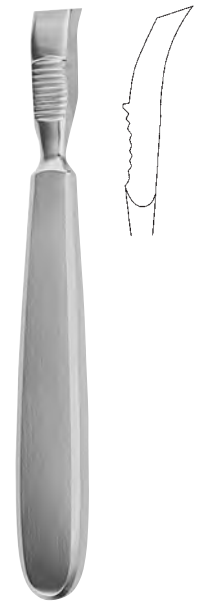

FARABEUF

024-441-150 15,0 cm / 6"

15,0 mm



SEDILOT

024-443-210 21,0 cm / 8 1/4"

4,0 mm

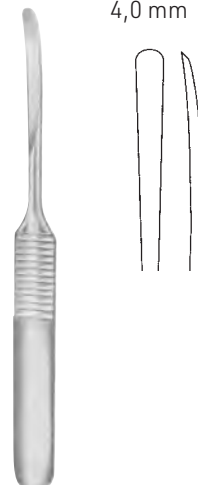

WILLIGER

024-445-140 14,0 cm / 5 1/2"

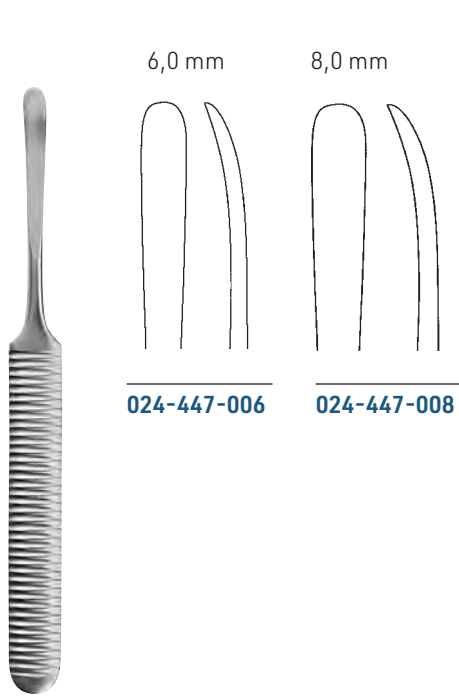

6,0 mm 8,0 mm

024-447-006 **024-447-008**

WILLIGER
024-447-006 - 024-447-008 16,0 cm / 6¹/₄"

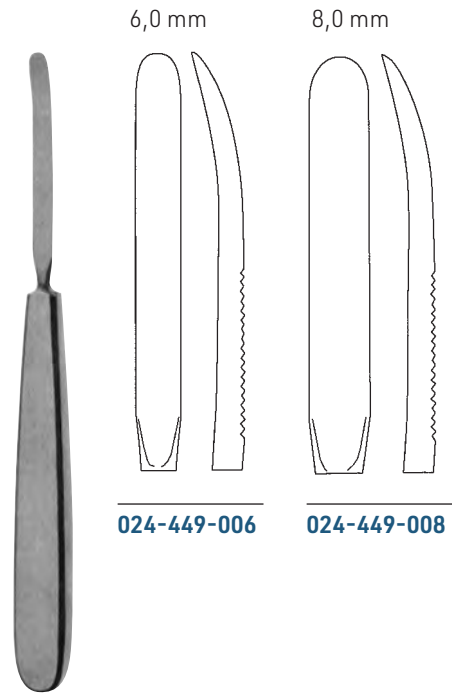

6,0 mm 8,0 mm

024-449-006 **024-449-008**

024-449-006 - 024-449-008 17,0 cm / 6³/₄"



Für Kinder
 for children
 para niños
 per bambini

DOYEN
024-451-170 17,0 cm / 6³/₄"



Für Kinder
 for children
 para niños
 per bambini

DOYEN
024-453-170 17,0 cm / 6³/₄"



024

Raspatorien
Raspatories
Periostótomos
Periostotomi



Für Erwachsene
for adults
para adultos
per adulti

DOYEN

024-455-170 17,0 cm / 6³/₄"

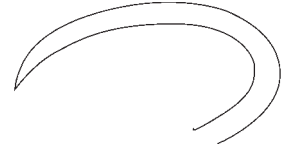

Für Erwachsene
for adults
para adultos
per adulti

DOYEN

024-457-170 17,0 cm / 6³/₄"



10,0 mm

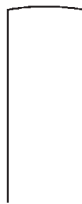

024-461-010

15,0 mm



024-461-015

20,0 mm

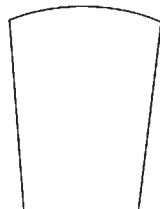

024-461-020

25,0 mm

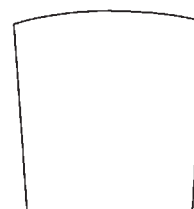

024-461-025

LAMBOTTE

024-461-010 - 024-461-025 21,0 cm / 8¹/₄"

12,0 mm

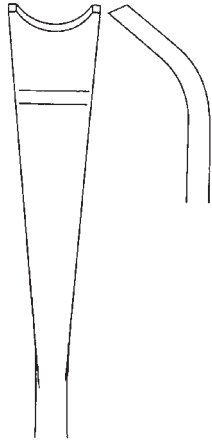

Fig. 1

024-463-001 19,0 cm / 7 1/2"

12,0 mm



Fig. 2

024-463-002 23,0 cm / 9"

13,0 mm

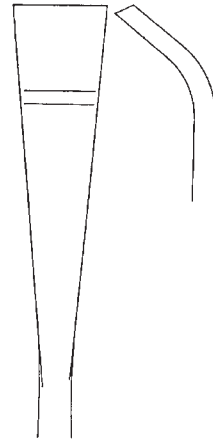

Fig. 3

024-463-003 23,0 cm / 9"



13,0 mm



Fig. 4

024-463-004 23,0 cm / 9"

16,0 mm



Fig. 5

024-463-005 23,0 cm / 9"

SEMB

024-463-001 - 024-463-005



024

Raspatorien
Raspatories
Periostótomos
Periostotomi



8,0 mm

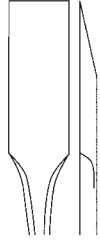

024-465-001

7,0 mm

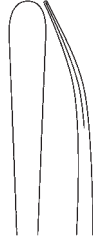

024-465-002

7,0 mm



024-465-003

7,0 mm

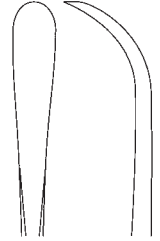

024-465-004

ADSON

024-465-001 - 024-465-004 17,0 cm / 6³/₄"



12,0 mm

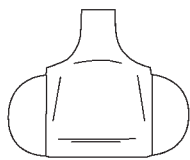
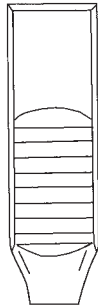

ALEXANDER

024-467-210 21,0 cm / 8¹/₄"

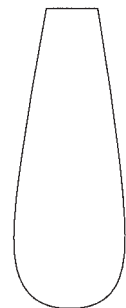
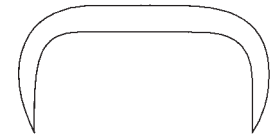

15,0 mm

MATSON

024-469-220 22,0 cm / 8³/₄"

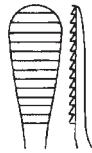

Fig. 1

024-501-001

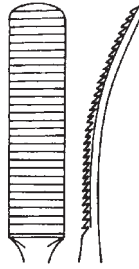

Fig. 2

024-501-002

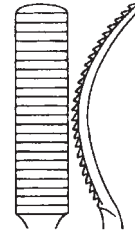

Fig. 3

024-501-003

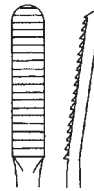
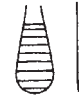
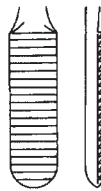
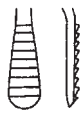

Fig. 4

024-501-004

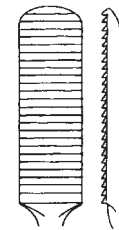
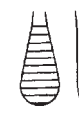

Fig. 5

024-501-005



abwärts schneidend
 downwards cutting
 corte abajo
 tagliente in basso

MILLER-COLBURN

024-501-001 - 024-501-005

18,0 cm / 7"



024

Knochenfeilen
Bone files
Limas para huesos
Lima per ossa

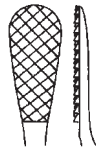

Fig. 1

024-503-001

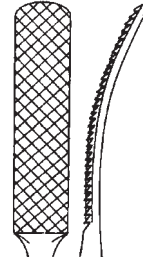

Fig. 2

024-503-002

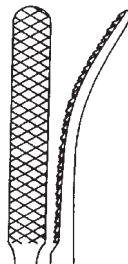
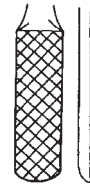

Fig. 3

024-503-003



Fig. 4

024-503-004

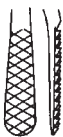

Kreuzhieb
cross cut
picado en cruz
tagleinte a croce

MILLER-COLBRUN

024-503-001 - 024-503-004

18,0 cm / 7"

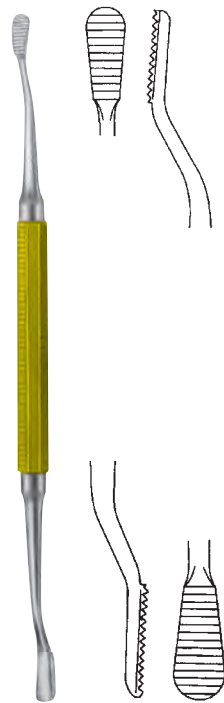

TC-MILLER-COLBRUN
024-505-185 18,5 cm / 7¹/₄"

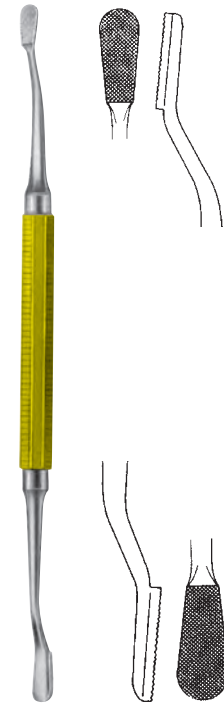

TC-MILLER-COLBRUN
024-507-185 18,5 cm / 7¹/₄"



024-510-280 28,0 cm / 11"



024-511-245 24,5 cm / 9²/₃"



024-512-220 22,0 cm / 8³/₄"



024

Knochenfeilen
Bone files
Limas para huesos
Lima per ossa



PUTTI

024-515-300 30,0 cm / 12"



PUTTI

024-517-270 27,0 cm / 10³/₄"



LANGENBECK

024-551-008 - 024-551-010 20,0 cm / 8"

8,0 mm

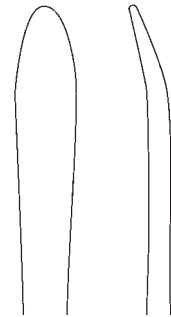

024-551-008

10,0 mm

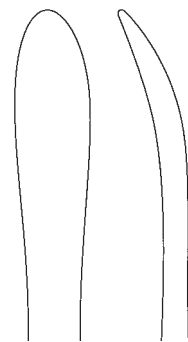

024-551-010

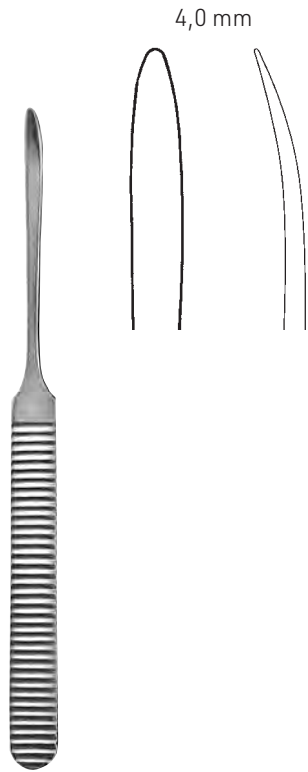

WILLIGER
024-553-170 17,0 cm / 6³/₄"

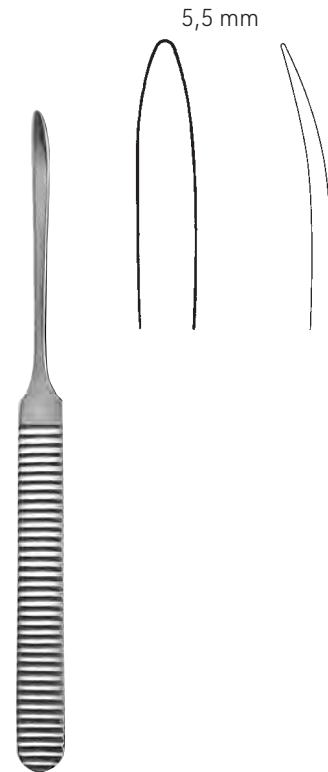

WILLIGER
024-555-160 16,0 cm / 6¹/₄"



extrem leicht
 very light
 estremamente ligero
 estremamente leggero

024-557-170 17,0 cm / 6³/₄"



Mikro-Elevatorium
 Micro-Elevator
 Micro-Elevador
 Micro-Elevatorio

024-559-160 16,0 cm / 6¹/₄"

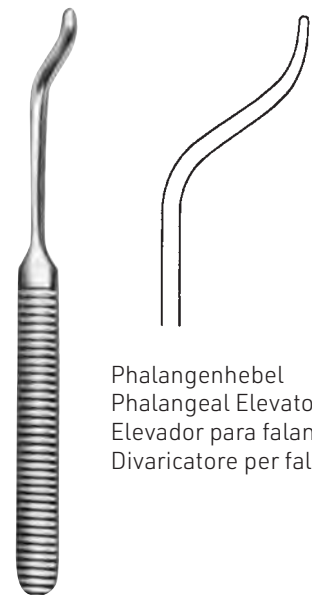

Phalangenhebel
 Phalangeal Elevator
 Elevador para falanges
 Divaricatore per falanghe

024-561-160 16,0 cm / 6¹/₄"



024

Dissektoren, Elevatorien
Dissectors, Elevators
Disectores, Elevadores
Dissettori, Elevatori

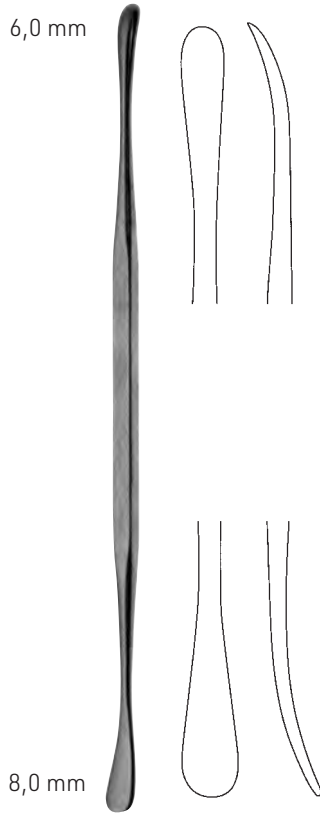

ALDERDYCE

024-563-210 21,0 cm / 8 1/4"

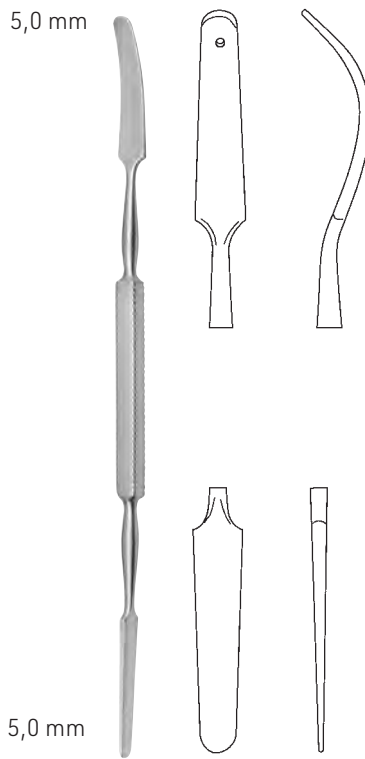

MC DONALD

024-565-190 19,0 cm / 7 1/2"

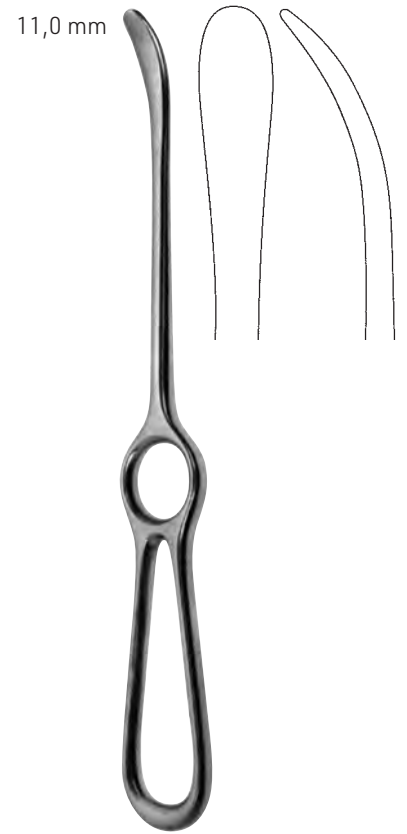

LANGENBECK

024-567-230 23,0 cm / 9"

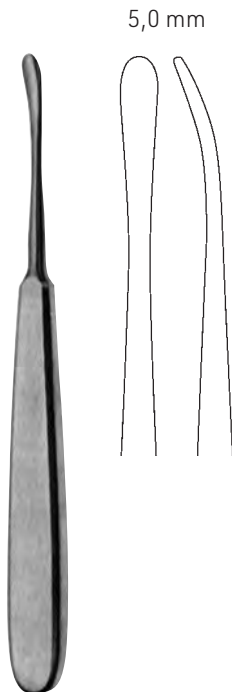

SEBILEAU

024-569-170 17,0 cm / 6 3/4"

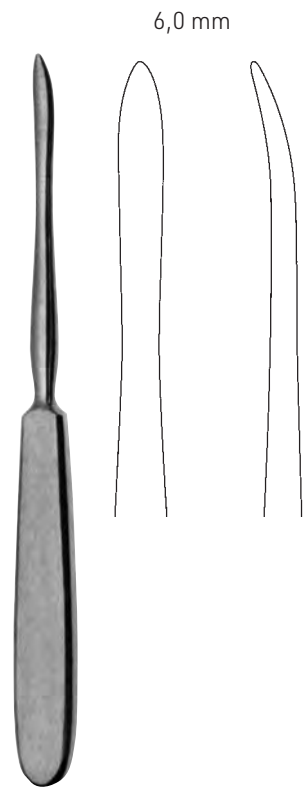

QUERVAIN

024-571-195 19,5 cm / 7 3/4"

2,8 mm

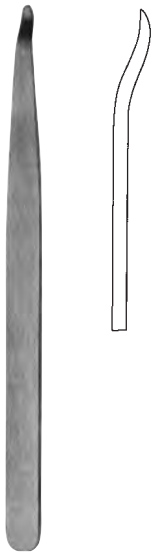

024-601-140 14,0 cm / 5 1/2"

5,0 mm

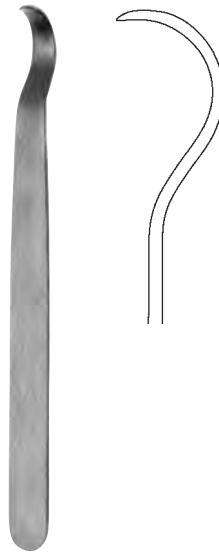

024-603-150 15,0 cm / 6"

7,0 mm

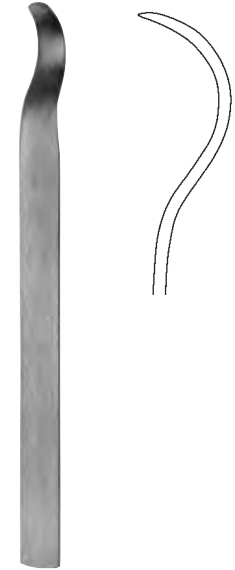

024-605-150 15,0 cm / 6 "

2,0 mm

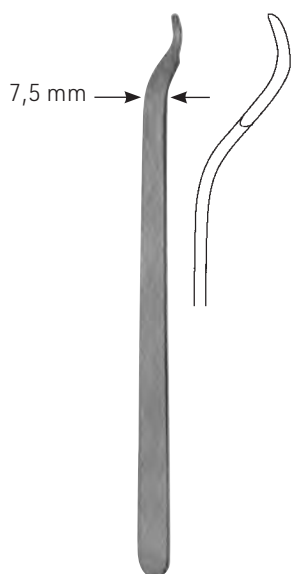

BUCK-GRAMCKO
024-607-150 15,0 cm / 6"

2,0 mm

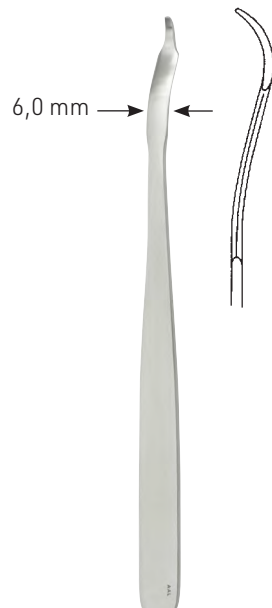

MINI-HOHMANN
024-609-006 16,0 cm / 6 1/4"

2,0 mm

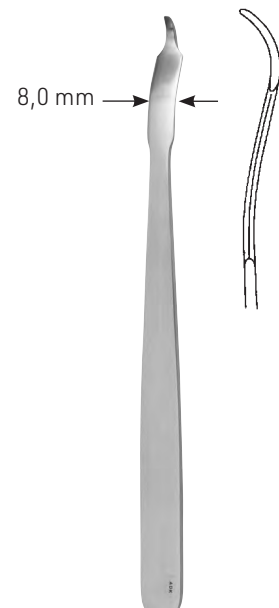

MINI-HOHMANN
024-609-008 16,0 cm / 6 1/4"



024

Knochenhebel
Bone Levers
Elevadores para huesos
Leve per ossa

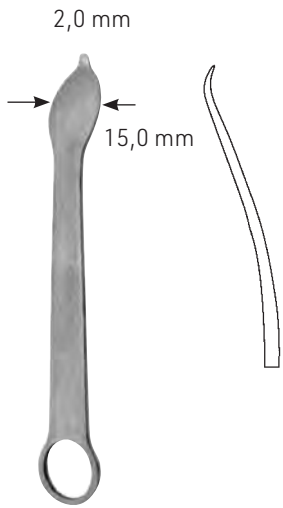

KNOCHENHEBEL

024-611-125 12,5 cm / 5"

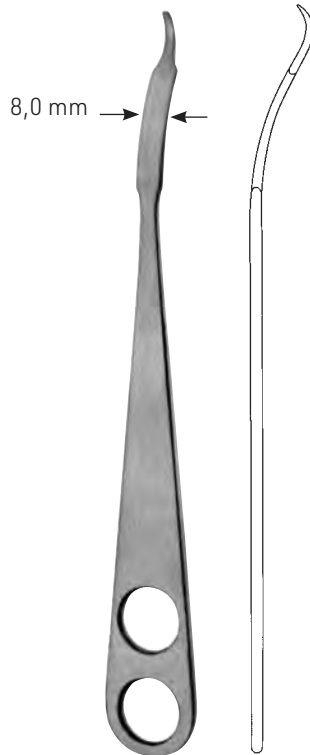

HOHMANN

024-613-220 22,0 cm / 8³/₄"

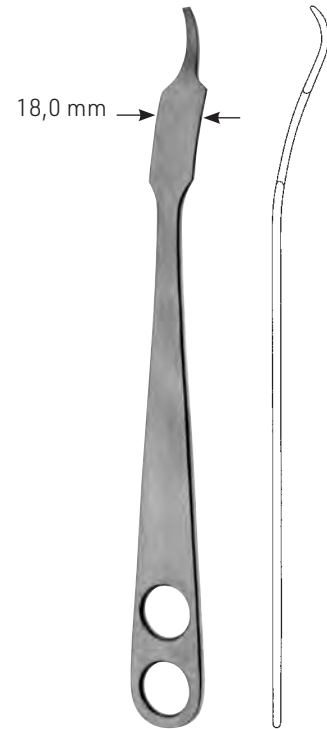

HOHMANN

024-615-235 23,5 cm / 9¹/₄"

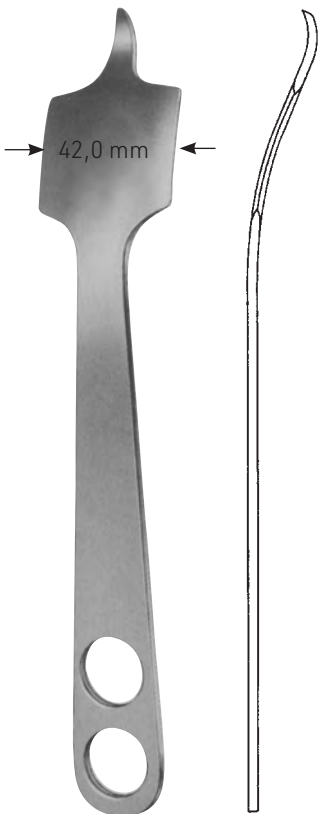

HOHMANN

024-617-240 24,0 cm / 9¹/₄"

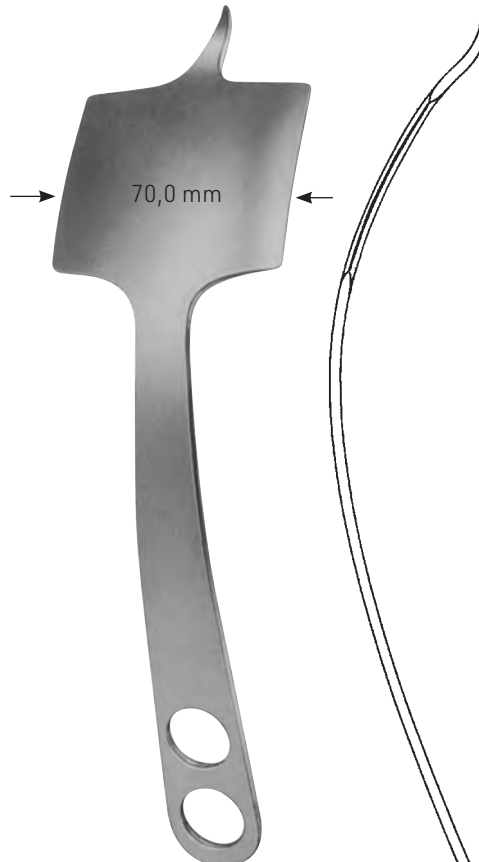

HOHMANN

024-619-250 25,0 cm / 9³/₄"

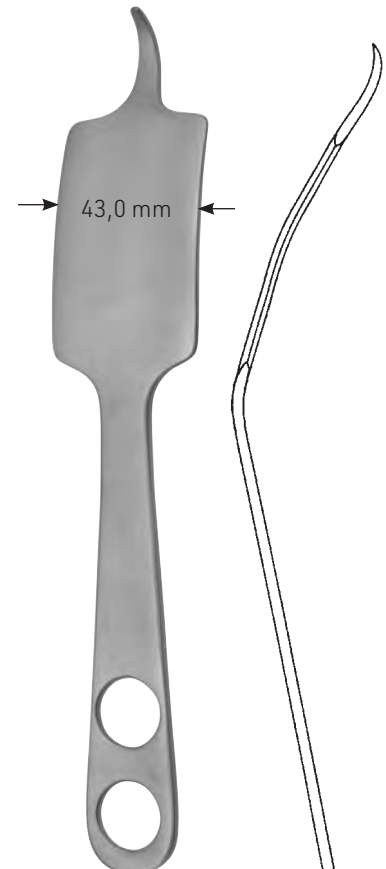

HOHMANN

024-621-235 23,5 cm / 9¹/₄"

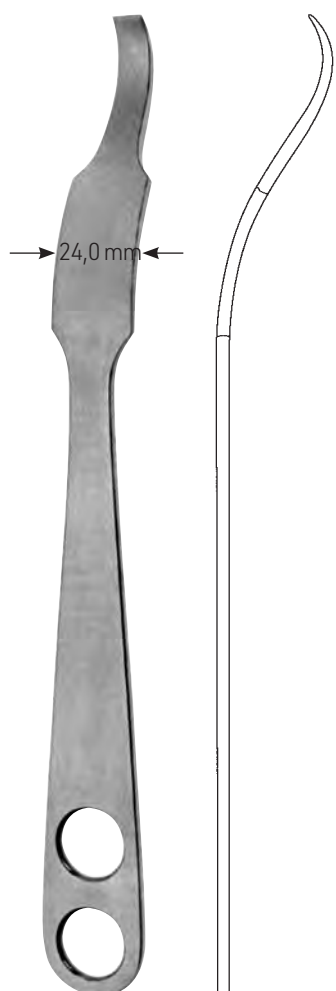

HOHMANN

024-623-260 26,0 cm / 10¹/₄"

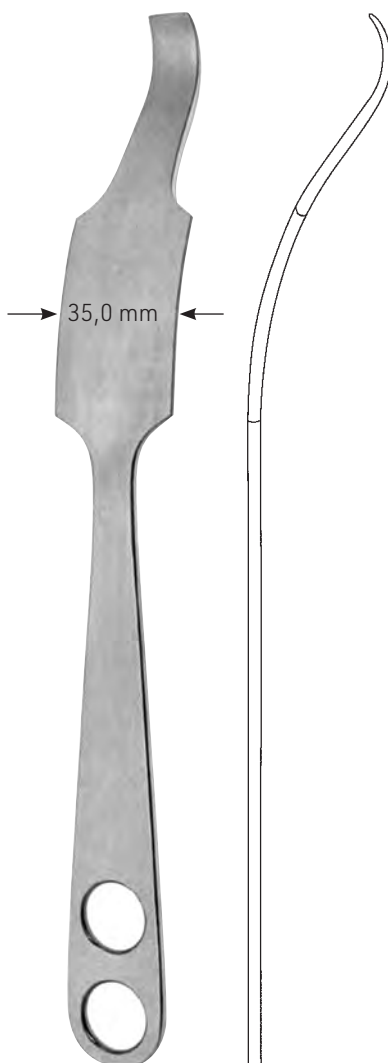

HOHMANN

024-625-290 29,0 cm / 11¹/₄"

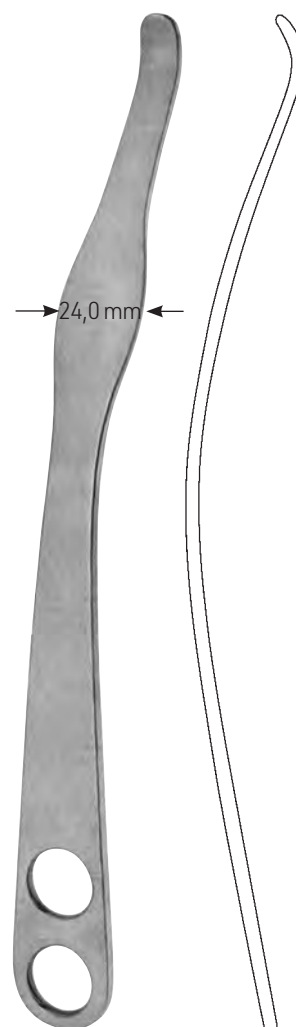

HOHMANN

024-627-275 27,5 cm / 10³/₄"



024

Knochenhebel
Bone Levers
Elevadores para huesos
Leve per ossa

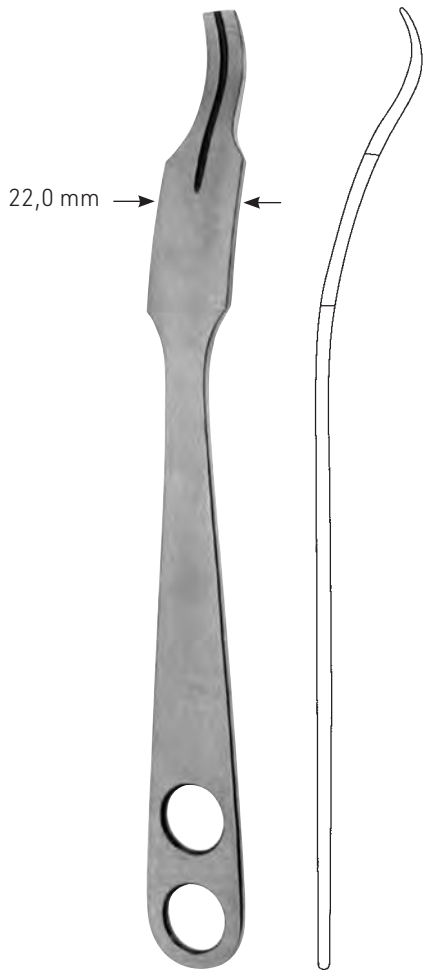

LANGE-HOHMANN

024-629-250 25,0 cm / 9³/₄"

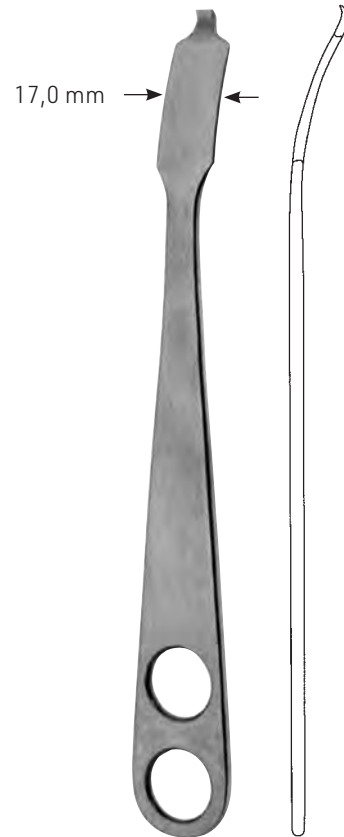

WAGNER

024-631-220 22,0 cm / 8³/₄"



HOHMANN-ALDINGER

024-633-280 28,0 cm / 11"

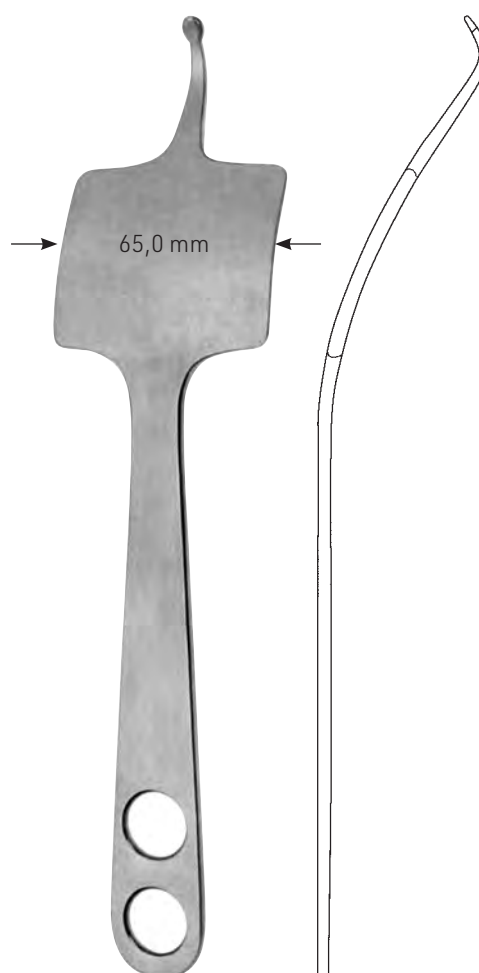

MÜLLER-VERBRUGGE

024-635-255 25,5 cm / 10"



024

Knochenhebel
Bone Levers
Elevadores para huesos
Leve per ossa

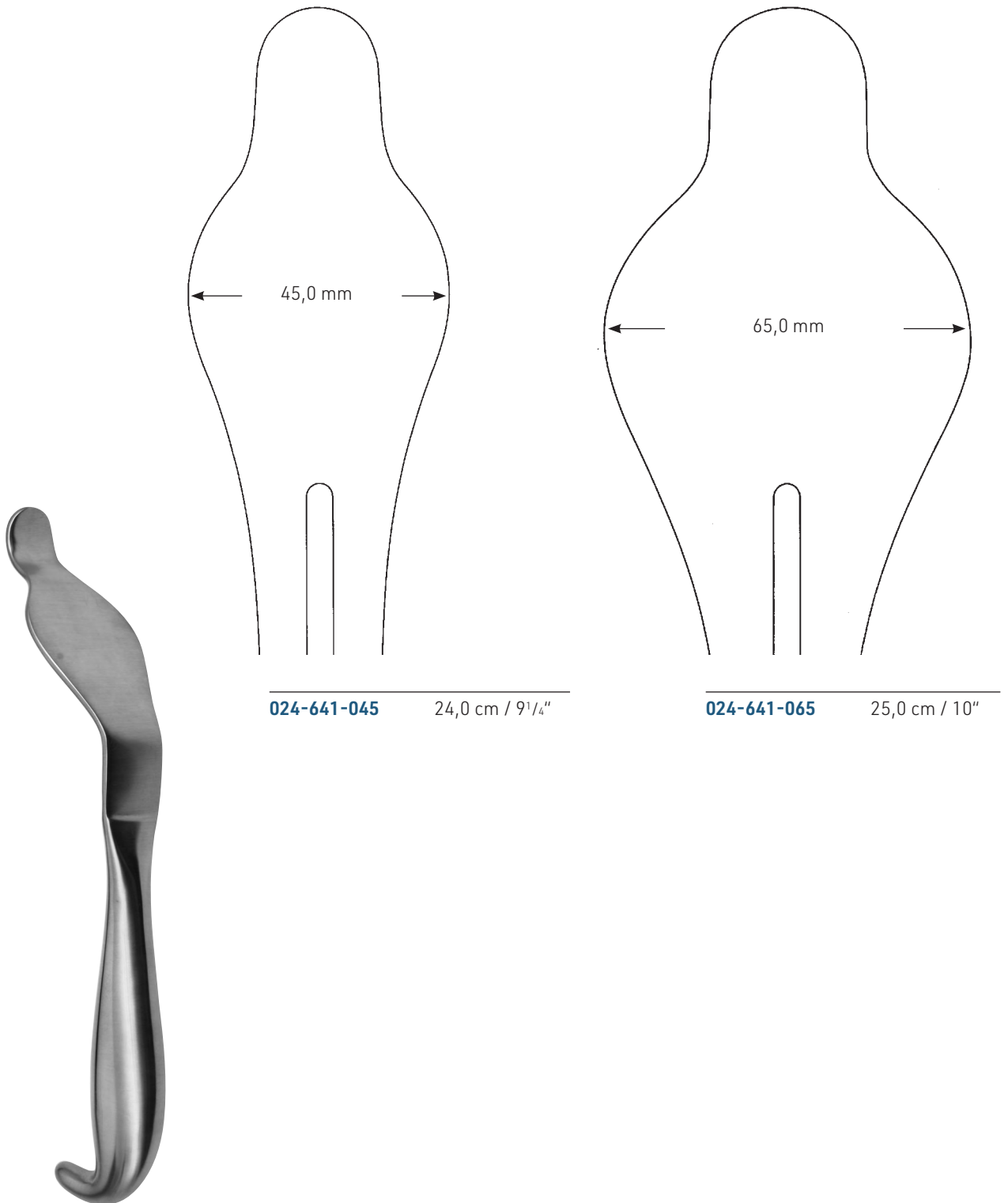

BENNET

024-641-045 - 024-641-065

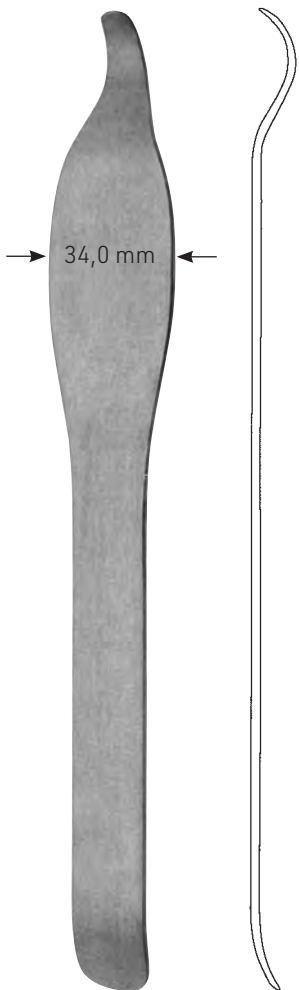

BLOUNT

024-643-260 26,0 cm / 10¹/₄"

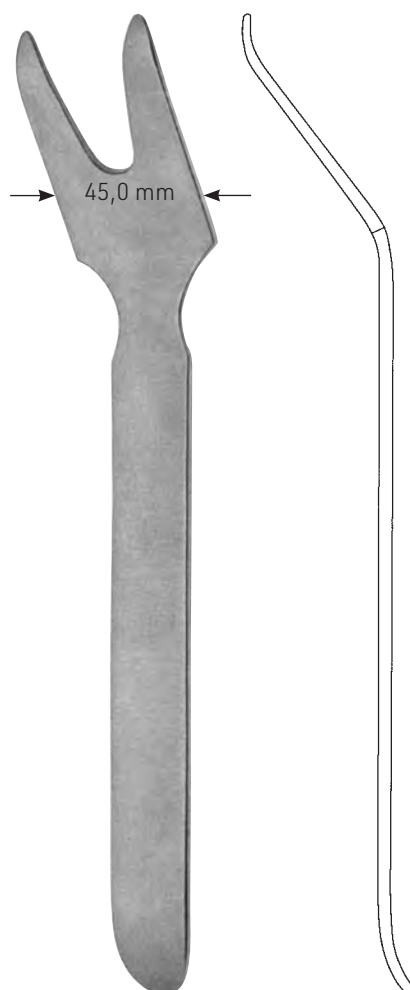

BLOUNT

024-645-260 26,0 cm / 10¹/₄"

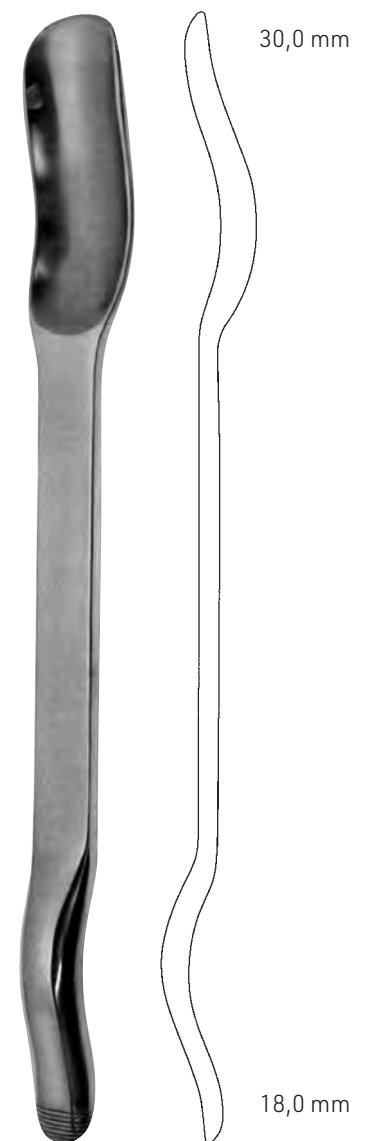

MURPHY-LANE

024-647-300 30,0 cm / 12"



024

Wund- und Meniskushaken
Retractor for Knee
Separadores para rodilla
Reptrattori per ginocchio



BLOUNT

024-649-175 17,5 cm / 7"

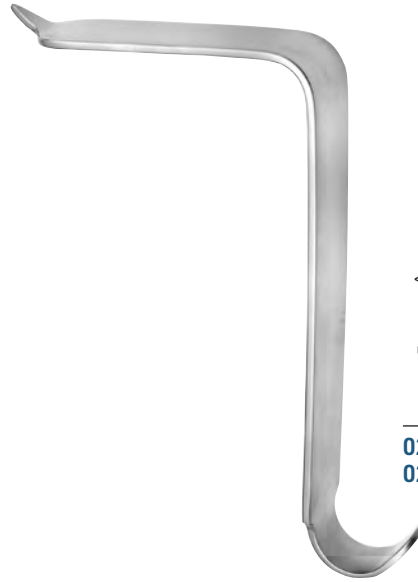

024-651-160

75 x 30 mm

024-653-160

100 x 30 mm

TAYLOR

024-651-160 - 024-653-160 16,0 cm / 6 1/2"



024-655-170 17,0 cm / 6 3/4"

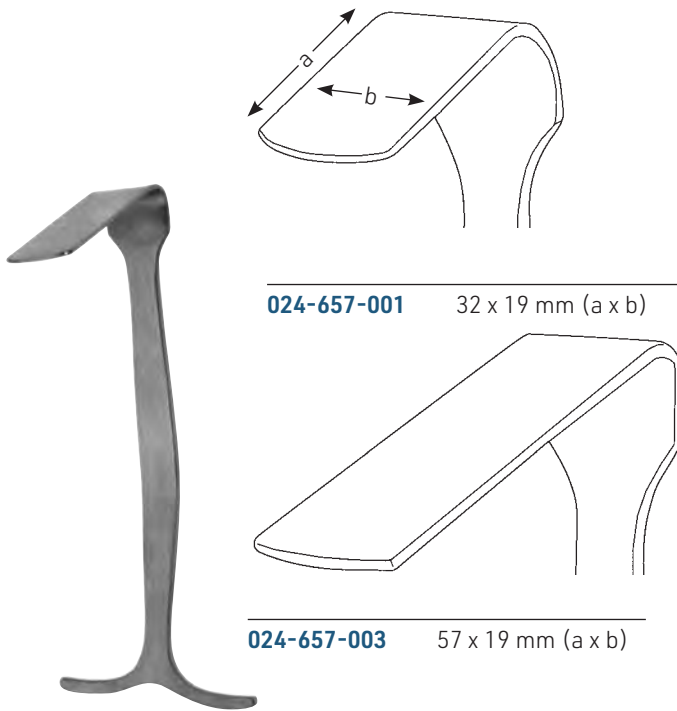

024-657-001 32 x 19 mm (a x b)

024-657-003 57 x 19 mm (a x b)

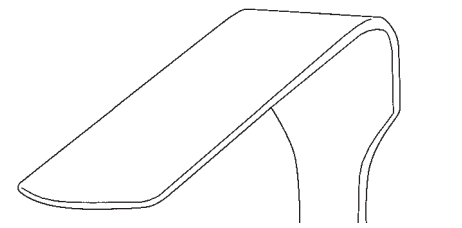

024-657-002 48 x 19 mm (a x b)

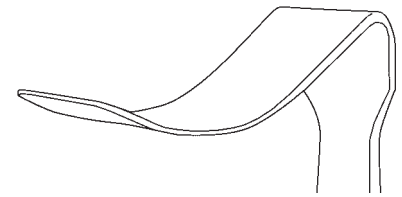

024-657-004 52 x 13 mm (a x b)

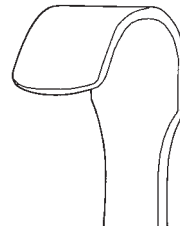

024-657-005 17 x 13 mm (a x b)

SMILLIE

024-657-001 - 024-657-005 14,0 cm / 5 1/2"



38 x 9 mm

024-659-210 21,0 cm / 8 1/4"



024

Meniskusmesser
Meniscus Knives
Bisturíes para menisco
Bisturi per menisco

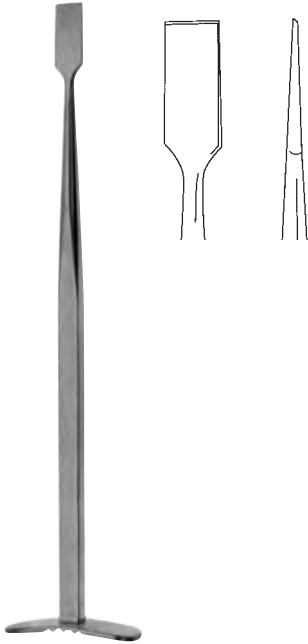

SMILLIE

024-660-170 17,0 cm / 6³/₂"

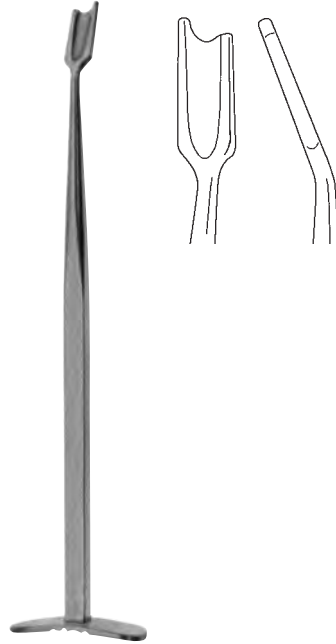

SMILLIE

024-661-170 17,0 cm / 6³/₄"

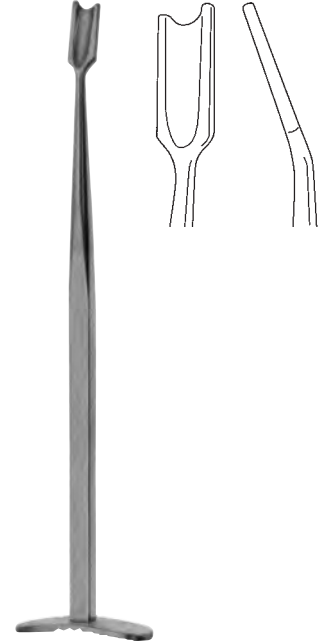

SMILLIE

024-663-170 17,0 cm / 6³/₄"



BIRCHER

024-665-001 19,0 cm / 7¹/₂"



BIRCHER

024-665-002 19,0 cm / 7¹/₂"



NEFF

024-667-001 20,5 cm / 8"

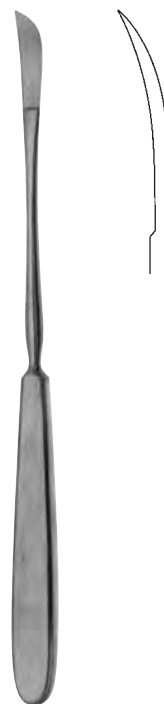

NEFF

024-667-002 20,5 cm / 8"



SALENIUS

024-669-001 22,0 cm / 8³/₄"

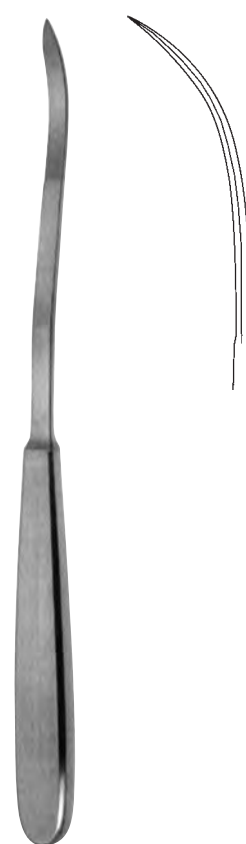

SALENIUS

024-669-002 22,0 cm / 8³/₄"



024

Sehnenführer, Sehnenschäler
Tendon Passing Instruments, Tendon Strippers
Conductor de tendónes, Mondador de tendónes
Guida per tendine, Enucleatore per tendine



024-671-180 18,0 cm / 7"



024-674-003 Ø 3,0 mm



024-674-004 Ø 4,0 mm



024-674-005 Ø 5,0 mm



024-674-006 Ø 6,0 mm



024-674-007 Ø 7,0 mm



BUNNELL

024-674-003 - 024-674-007 15,0 cm / 6"



024-676-004 Ø 4,0 mm



024-676-005 Ø 4,5 mm



024-676-006 Ø 5,5 mm



flexibler Schaft
flexible shaft
vástago flexible
gambo flessibile

024-676-004 - 024-676-006 23,0 cm / 9"

Ø 4,0 mm



FISHER

024-680-310 31,0 cm / 12¹/₄"

Ø 5,0 mm



BUNNELL

024-682-230 23,0 cm / 9"



024

Sehnenführungsangen und Sehnenfaßzangen
 Tendon Holding Forceps and Tendon Seizing Forceps
 Pinzas-conductoras de tendónes y Pinzas para agarrar tendónes
 Pinze ferma tendine e Pinze per la presa del tendine



024-704-150



024-704-190



024-704-240

BRAND

- 024-704-150 15,0 cm / 6"
- 024-704-190 19,0 cm / 7 1/2"
- 024-704-240 24,0 cm / 9 1/2"



024-705-150



024-705-190



024-705-240

BRAND

- 024-705-150 15,0 cm / 6"
- 024-705-190 19,0 cm / 7 1/2"
- 024-705-240 24,0 cm / 9 1/2"

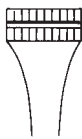

STEINMANN

024-702-160 16,0 cm / 6 1/4"



024-708-205



024-709-205

024-708-205 - 024-709-205 20,5 cm / 8"



CAROLL

024-711-110 11,0 cm / 4³/₈"

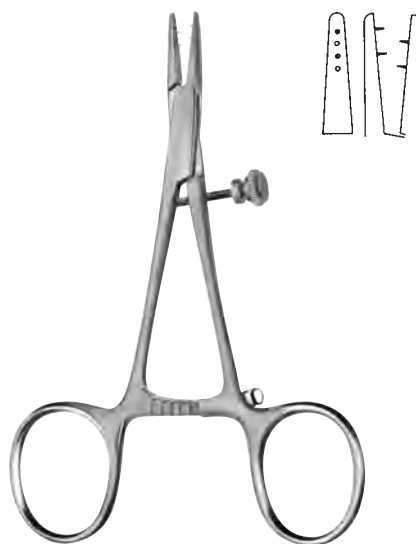

024-716-115 11,5 cm / 4¹/₂"t



KLEINERT-KUTZ

024-720-020 Ø 2,0 mm 20,5 cm / 8"
024-720-025 Ø 2,5 mm 20,5 cm / 8"



024-724-150 15,0 cm / 6"

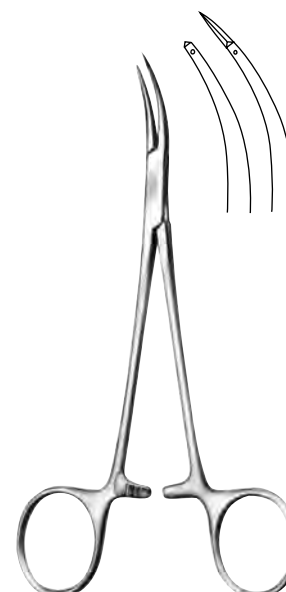

024-725-150 15,0 cm / 6"



024

Knorpelfasszangen
Cartilage Seizing Forceps
Pinzas para cartilago
Pinze per cartilagine



BIRCHER-GANSKE

024-730-205 20,5 cm / 8"

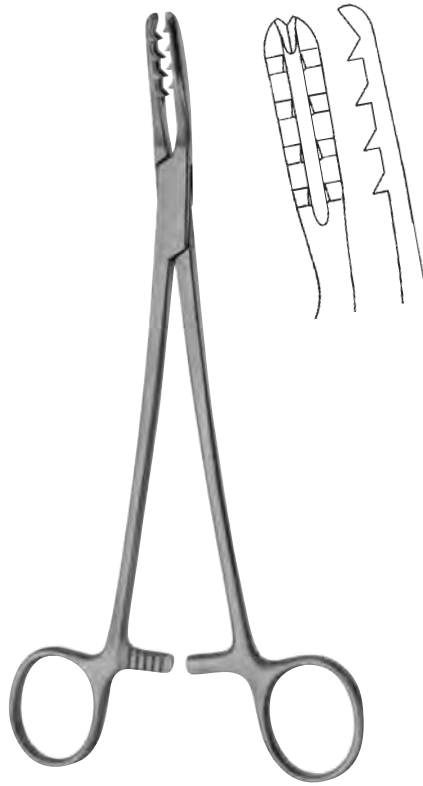

BIRCHER-GANSKE

024-731-205 20,5 cm / 8"

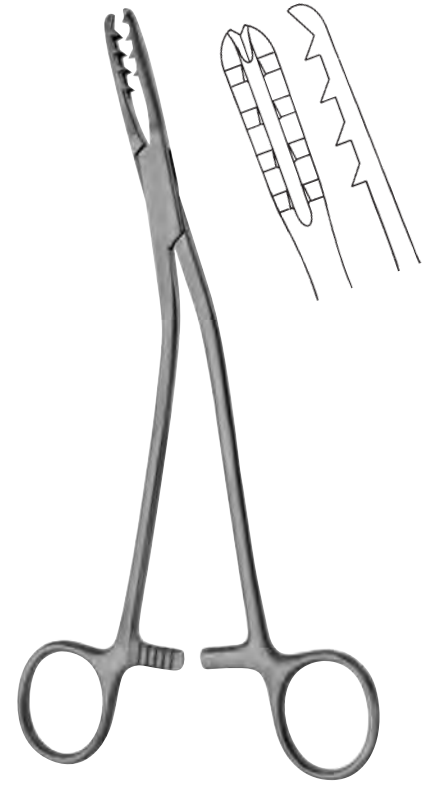

BIRCHER-GANSKE

024-733-200 20,0 cm / 8"



024-735-140 14,0 cm / 5 1/4"



DINGMANN

024-737-185 18,5 cm / 7 1/4"



MARTIN

024-740-185 18,5 cm / 7 1/4"

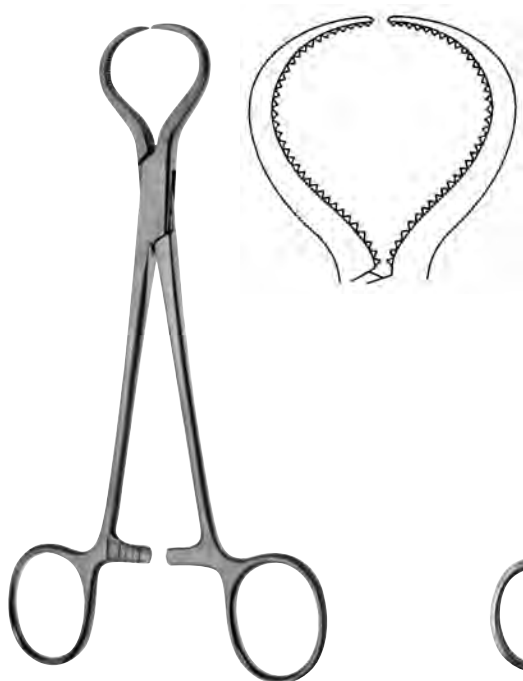

LEWIN

024-742-180 18,0 cm / 7"



024-745-140 14,0 cm / 5 1/2"



024-748-140 14,0 cm / 5 1/2"



lange Sperre, scharf
 long ratchet, pointed
 cremallera larga, aguda
 cremagliera lunga, acuta

024-749-135 13,5 cm / 5 1/4"



024-751-205 20,5 cm / 8"



024

Sequesterzangen, Knochenhaltezangen
Sequestrum Forceps, Bone Holding Forceps
Pinzas para secuestro; Pinzas para huesos
Pinze per frammento osseo, Tenaglie per ossa



024-760-200 20,0 cm / 8"



024-761-200 20,0 cm / 8"

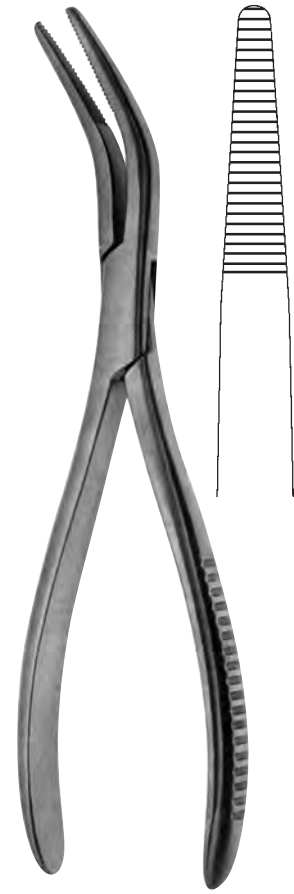

VAN BUREN
024-763-230 23,0 cm / 9"



LANGENBECK
024-766-210 21,0 cm / 9"



FERGUSSON
024-768-210 21,0 cm / 8¹/₄"

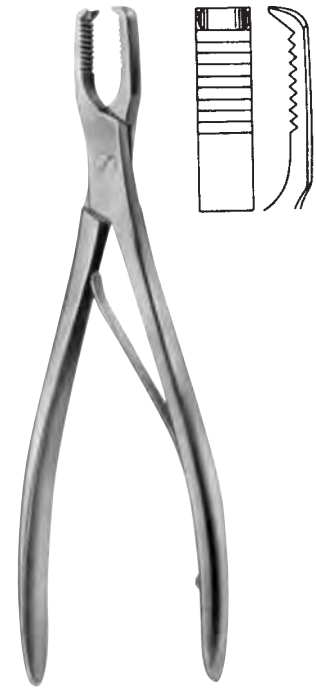

FROSCH
024-770-180 18,0 cm / 7"



LANGENBECK

024-772-200 20,0 cm / 8"



024-775-160

024-775-160 16,0 cm / 6 1/4"
024-775-240 24,0 cm / 9 1/2"

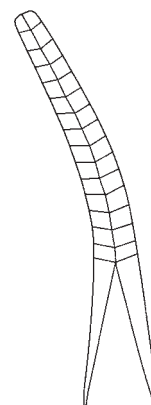
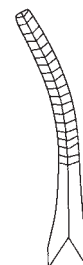

024-775-240



BABY-KERN

024-780-150 15,0 cm / 6"

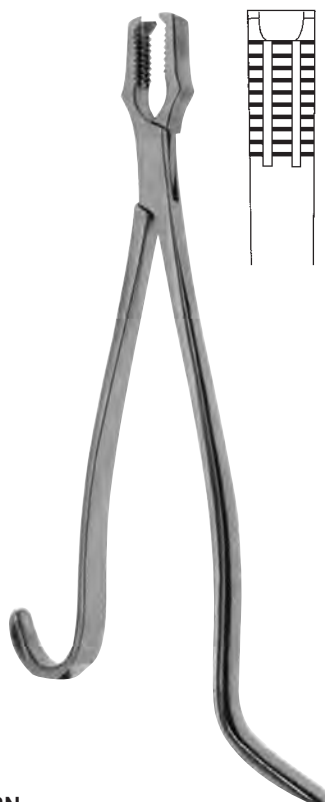

KERN

024-780-170 17,0 cm / 6 3/4"
024-780-210 21,0 cm / 8 1/4"



024

Knochenhalte­zangen
Bone Holding Forceps
Pinzas para huesos
Tenaglie per ossa



BABY-KERN

024-782-150 15,0 cm / 6"



KERN

024-782-170 17,0 cm / 6³/₄"
024-782-210 21,0 cm / 8¹/₄"



SEMB

024-785-190 19,0 cm / 7³/₄"



FARABEUFG

024-790-230 23,0 cm / 9"
024-790-260 26,0 cm / 10¹/₄"

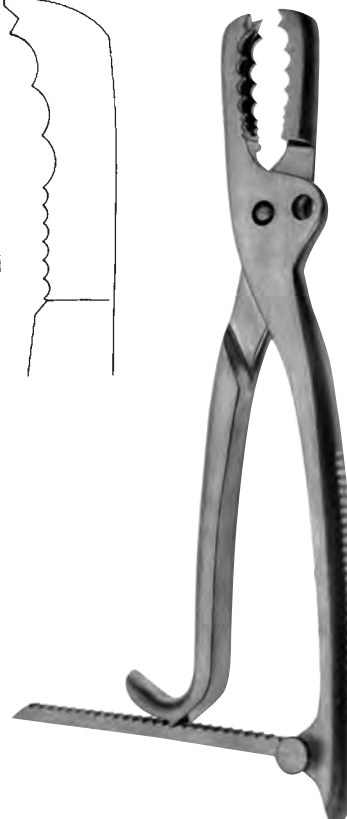
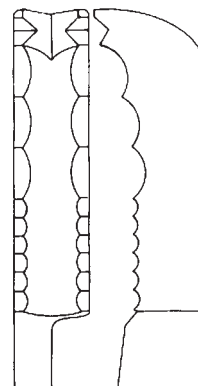

FARABEUFG-LAMBOTTE

024-792-260 26,0 cm / 10"

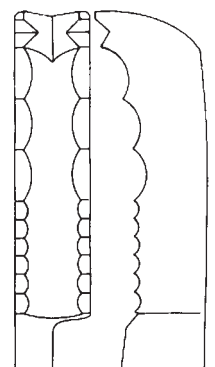

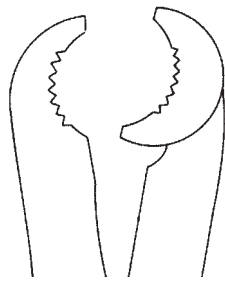

024-796-220

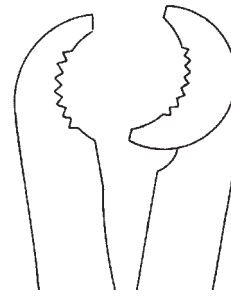

024-796-270

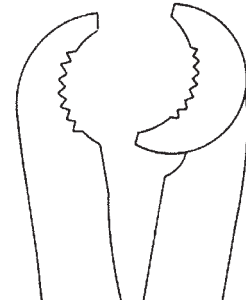

024-796-300

LAMBOTTE

- 024-796-220 22,0 cm / 8³/₄"
- 024-796-270 27,0 cm / 10³/₄"
- 024-796-300 30,0 cm / 11³/₄"

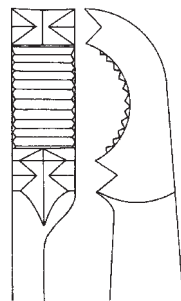

TUFFIER

- 024-794-270 27,0 cm / 10³/₄"

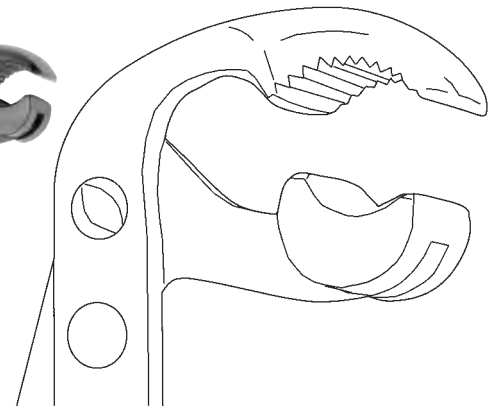

LAMBOTTE

- 024-799-190 19,0 cm / 7¹/₂"



024

Knochenhalte­zangen
Bone Holding Forceps
Pinzas para huesos
Tenaglie per ossa



LANE

024-800-330 33,0 cm / 13"
024-800-450 45,0 cm / 17³/₄"

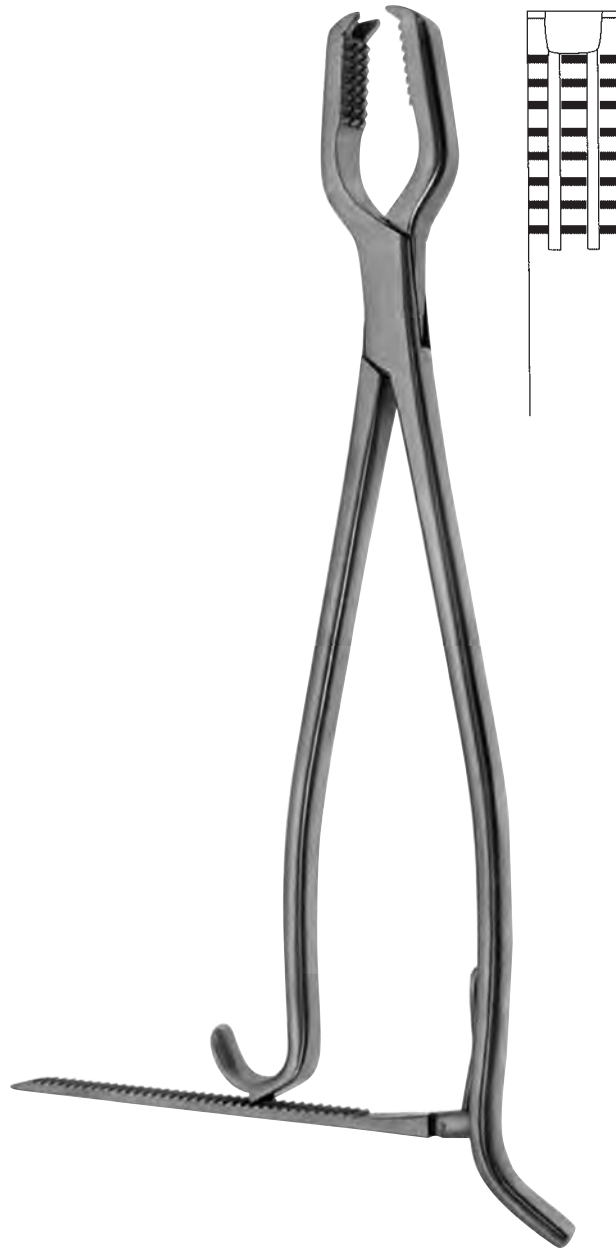

LANE

024-802-330 33,0 cm / 13"
024-802-450 45,0 cm / 17³/₄"



5,0 mm

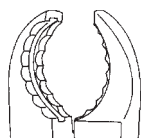

024-810-180

7,5 mm

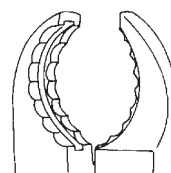

024-810-230

8,0 mm

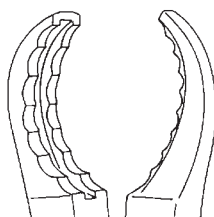

024-810-250

8,5 mm

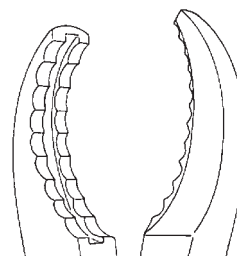

024-810-280

ULRICH

024-810-180	18,0 cm / 7"
024-810-230	23,0 cm / 9"
024-810-250	25,0 cm / 10"
024-810-280	28,0 cm / 11"



024

Knochenhalte­zangen
Bone Holding Forceps
Pinzas para huesos
Tenaglie per ossa

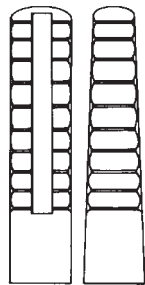

5,0 mm

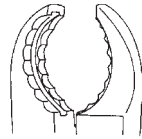

024-811-180

7,5 mm

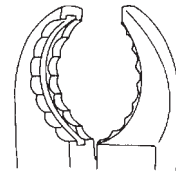

024-811-230

8,0 mm

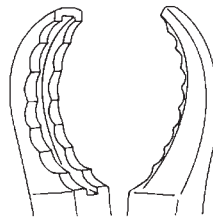

024-811-250

8,5 mm

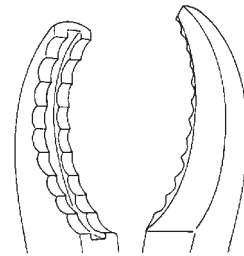

024-811-280

ULRICH

024-811-180	18,0 cm / 7"
024-811-230	23,0 cm / 9"
024-811-250	25,0 cm / 10"
024-811-280	28,0 cm / 11"

2,5 mm

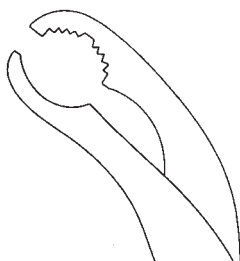

024-815-150

6,5 mm

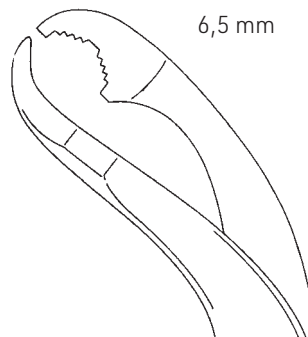

024-815-190

selbstzentrierend mit Gewin­desperre
 self-centering forceps with thread fixation
 autocentrante con cremallera de rosca
 pinze autocentranti con blocco di filettatura



9,5 mm

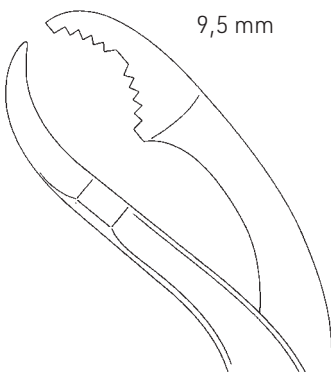

024-815-240

10,0 mm

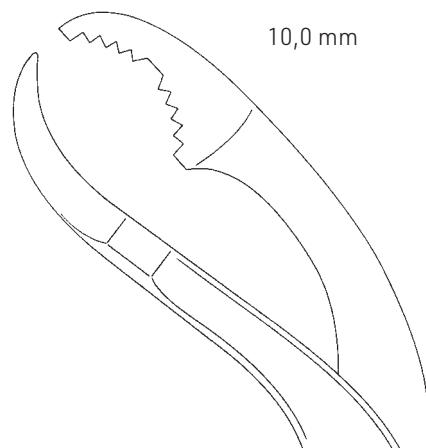

024-815-260

11,0 mm

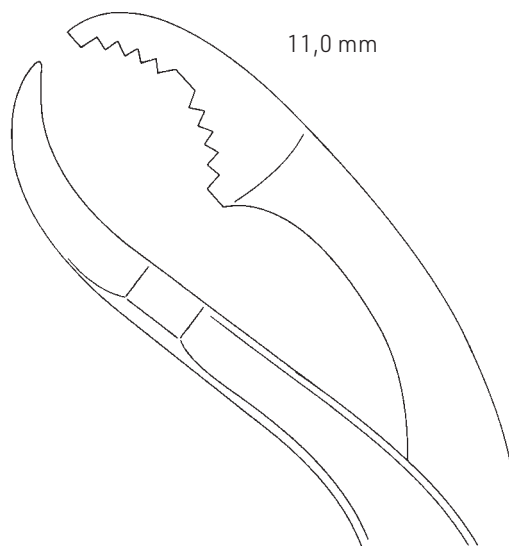

024-815-280

024-815-150	15,0 cm / 6"
024-815-190	19,0 cm / 7 1/2"
024-815-240	24,0 cm / 9 1/2"
024-815-260	26,0 cm / 10 1/4"
024-815-280	28,0 cm / 11"



024

Knochenhalte­zangen
Bone Holding Forceps
Pinzas para huesos
Tenaglie per ossa

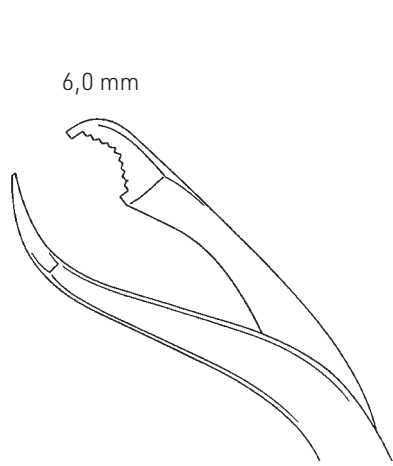

024-819-175

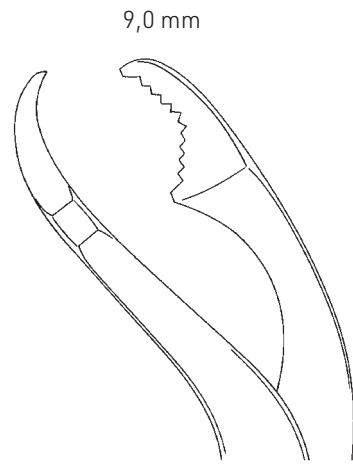

024-819-250

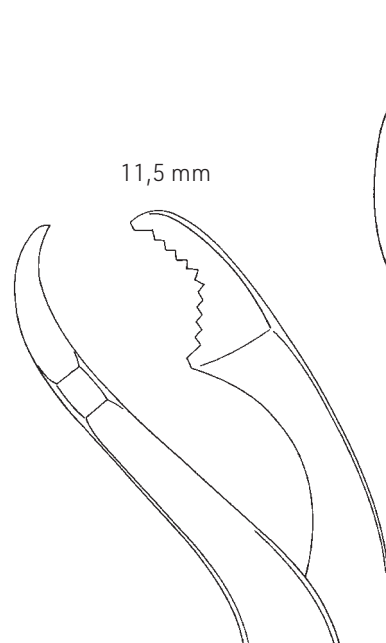

024-819-260

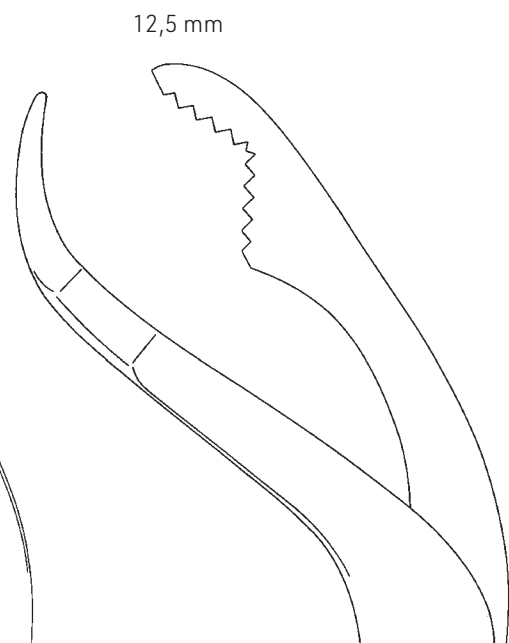

024-819-270

VERBRUGGE

024-819-175	17,5 cm / 7"
024-819-250	25,0 cm / 10"
024-819-260	26,0 cm / 10 ¹ / ₄ "
024-819-270	27,0 cm / 10 ³ / ₄ "

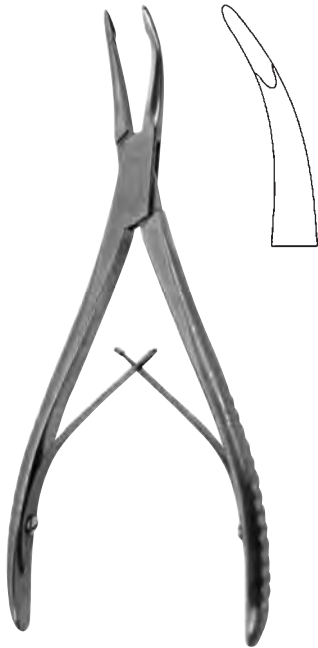

STELLBRINK
024-851-001 17,5 cm / 7"

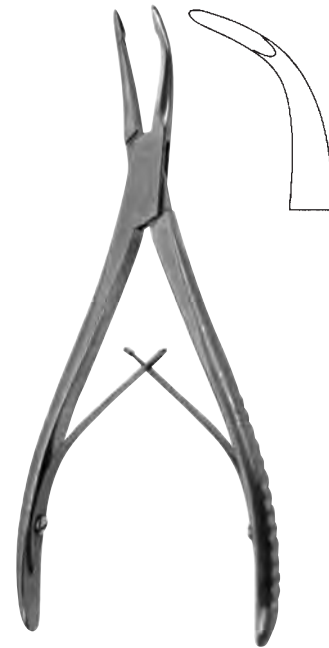

STELLBRINK
024-851-002 17,5 cm / 7"

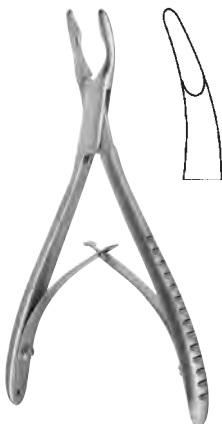

MINI-FRIEDMANN
024-853-120 12,0 cm / 4³/₄"

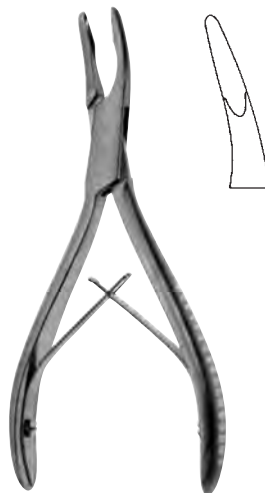

FRIEDMANN
024-855-140 14,0 cm / 5¹/₂"

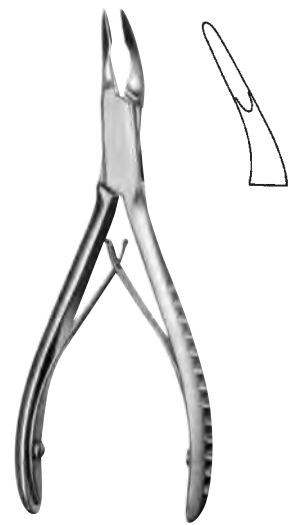

FRIEDMANN-VICKERS
024-857-140 14,0 cm / 5¹/₂"



024

Hohlmeißelzangen
Bone Rongeurs
Pinzas-gubias
Pinze per ossa



CLEVELAND

024-859-140 14,0 cm / 5 1/2"



CLEVELAND

024-859-170 17,0 cm / 6 3/4"



MEAD

024-861-165 16,5 cm / 6 1/2"



HARTMANN

024-863-180 18,0 cm / 7"



JANSEN

024-866-180 18,0 cm / 7"
024-867-180 18,0 cm / 7"
024-869-180 18,0 cm / 7"



024-866-180



024-867-180



024-869-180

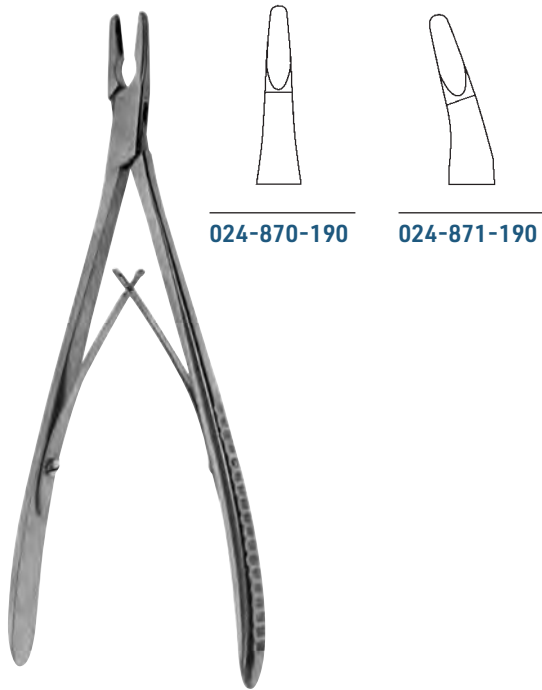

024-870-190

024-871-190

LEMPERT

024-870-190 - 024-871-190 19,0 cm / 7 1/2"

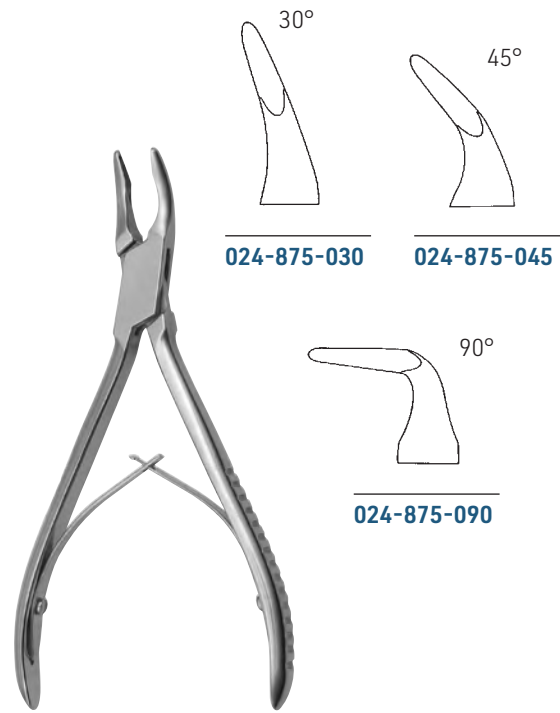

024-875-030

024-875-045

024-875-090

BLUMENTHAL

024-875-030 - 024-875-090 15,5 cm / 6"

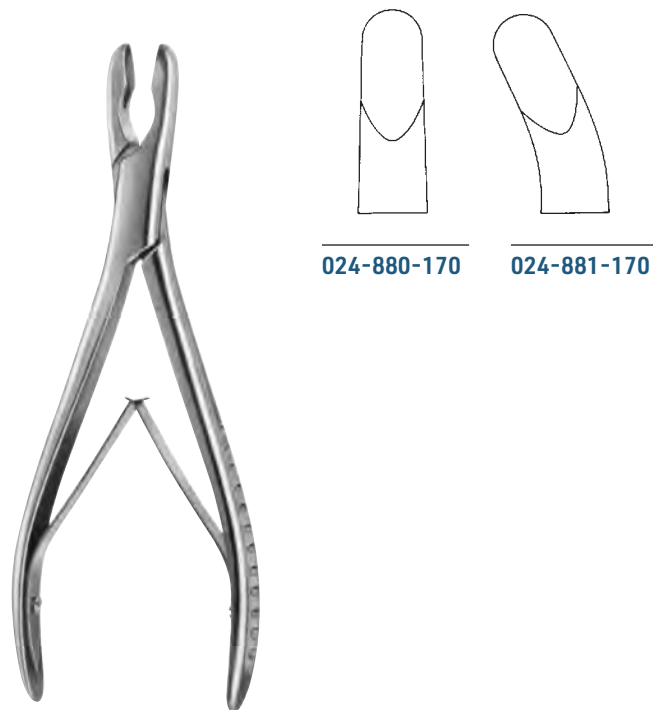

024-880-170

024-881-170

LUER

024-880-170 17,0 cm / 6 3/4"
 024-881-170 17,0 cm / 6 3/4"

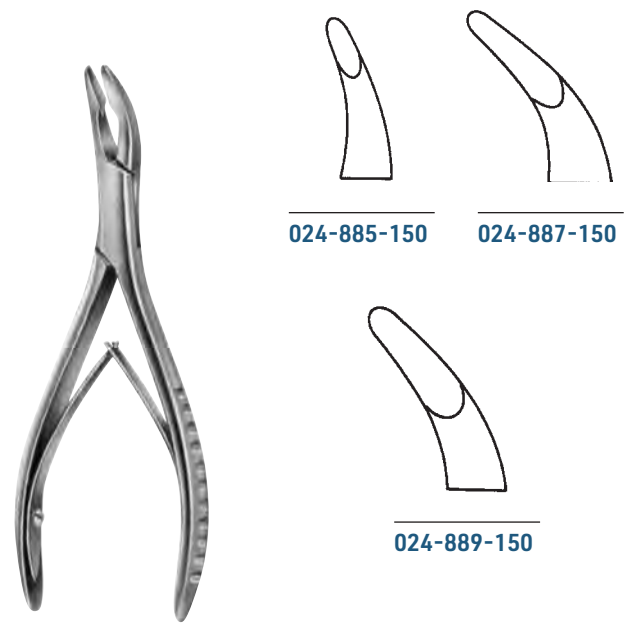

024-885-150

024-887-150

024-889-150

LUER

024-885-150 - 024-889-150 14,5 cm / 5 3/4"



024

Hohlmeißelzangen
Bone Rongeurs
Pinzas-gubias
Pinze per ossa

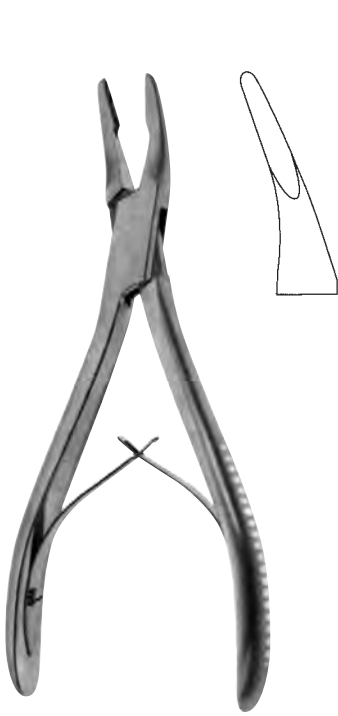

BEYER

024-891-180 18,0 cm / 7"

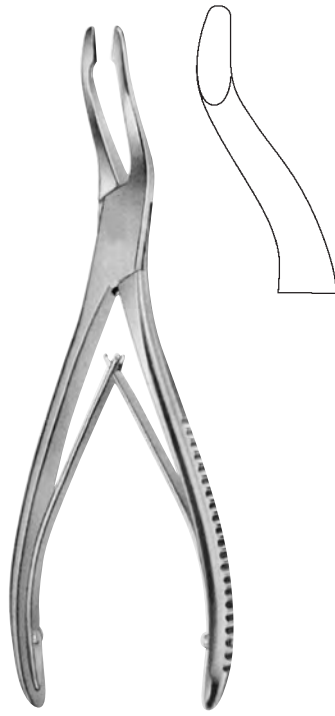

JANSEN

024-893-190 19,0 cm / 7 1/2"

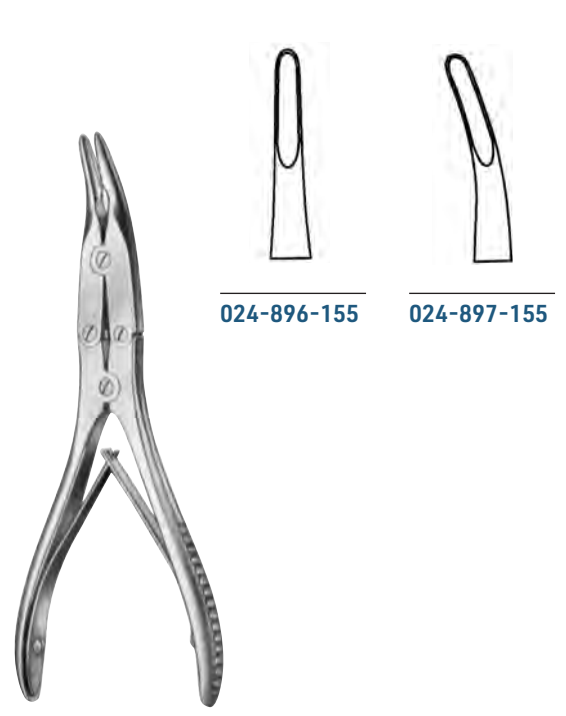

BÖHLER

024-896-155 - 024-897-155 15,5 cm / 6"

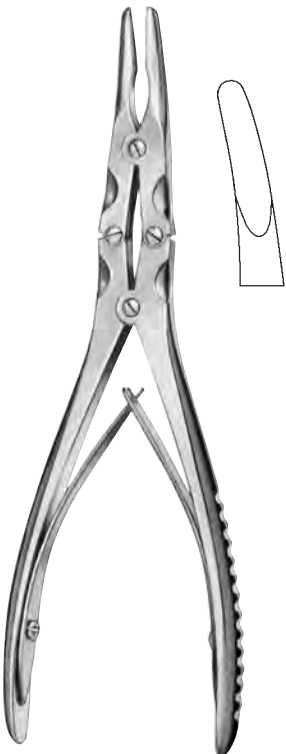

BEYER

024-899-180 18,0 cm / 7"



ZUFAL-JANSEN

024-901-180 18,0 cm / 7"

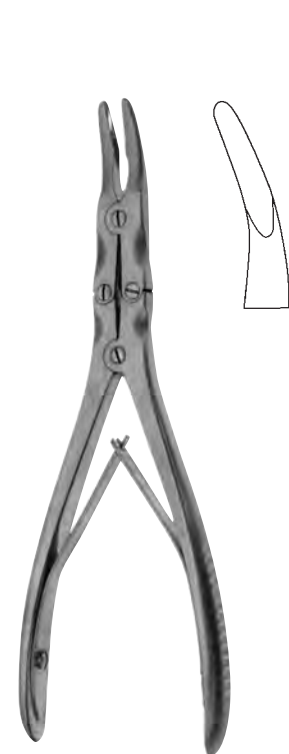

MAYFIELD

024-903-175 17,5 cm / 7"



MARQUARDT
 024-905-200 20,0 cm / 8"



RUSKIN
 024-907-180 18,0 cm / 7"



RUSKIN
 024-909-240 24,0 cm / 9 1/2"

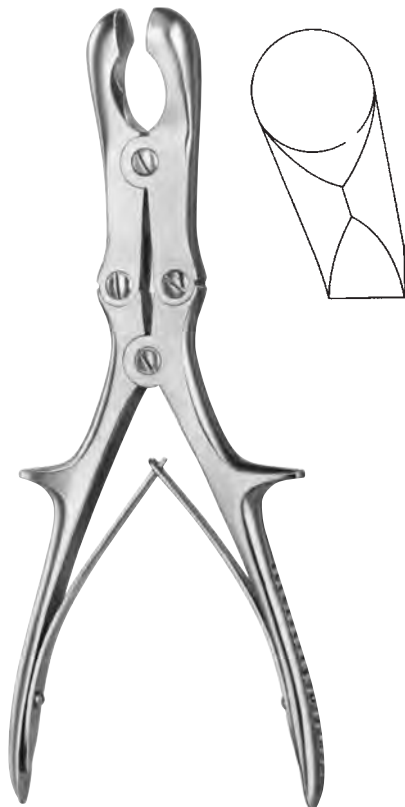

SEMB
 024-911-235 23,5 cm / 9 1/4"



STILLE
 024-913-004 - 024-913-008 23,0 cm / 9"



024-913-004



024-913-006

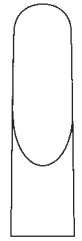

024-913-008



024

2,0 mm

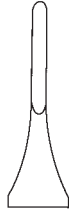

024-915-002

3,0 mm



024-915-003

4,0 mm



024-915-004



ECHLIN

024-915-002 - 024-915-004

23,0 cm / 9"



STILLE RUSKIN

024-917-230 23,0 cm / 9"

3,0 mm



024-919-003

5,0 mm



024-919-005

8,0 mm



024-919-008

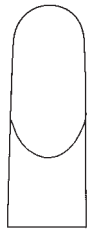

024-922-220

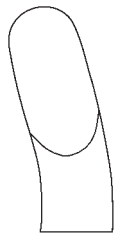

024-923-220

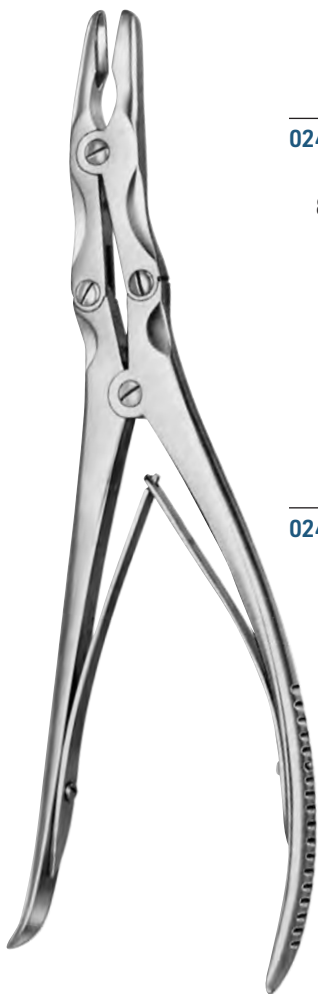

LEKSELL-STILLE

024-919-003 - 024-919-008 24,5 cm / 9³/₄"

FRYKHOLM

024-921-240 24,5 cm / 9³/₄"

STILLE-LUER

024-922-220 - 024-923-220 22,0 cm / 8³/₄"



024

Hohlmeißelzangen
Bone Rongeurs
Pinzas-gubias
Pinze per ossa

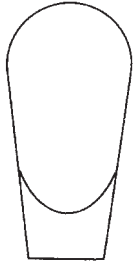

024-924-230
024-924-270



024-926-300

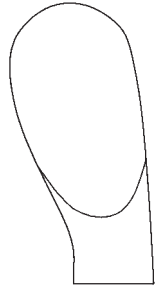

024-925-230
024-925-270



024-928-300



STILLE-LUER

024-924-230 – 024-925-230 23,0 cm / 9"
024-924-270 – 024-925-270 27,0 cm / 10³/₄"

SAUERBRUCH

024-926-300 – 024-928-300 30,0 cm / 11³/₄"



LISTON

024-934-140	14,0 cm / 5 ¹ / ₂ "
024-934-170	17,0 cm / 6 ³ / ₄ "
024-934-190	19,0 cm / 7 ¹ / ₂ "
024-934-220	22,0 cm / 8 ³ / ₄ "

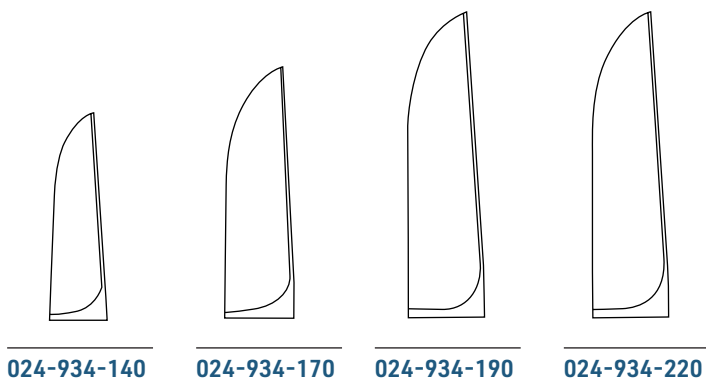

024-934-140 **024-934-170** **024-934-190** **024-934-220**



LISTON

024-935-140	14,0 cm / 5 ¹ / ₂ "
024-935-170	17,0 cm / 6 ³ / ₄ "
024-935-190	19,0 cm / 7 ¹ / ₂ "
024-935-220	22,0 cm / 8 ³ / ₄ "

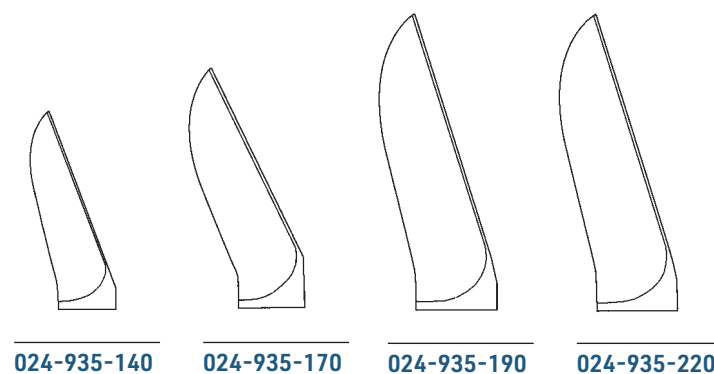

024-935-140 **024-935-170** **024-935-190** **024-935-220**



024

Knochensplitterzangen
Bone Cutting Forceps
Pinzas cortantes para huesos
Cesoie per ossa



MARKWALDER

024-931-200 20,0 cm / 8"

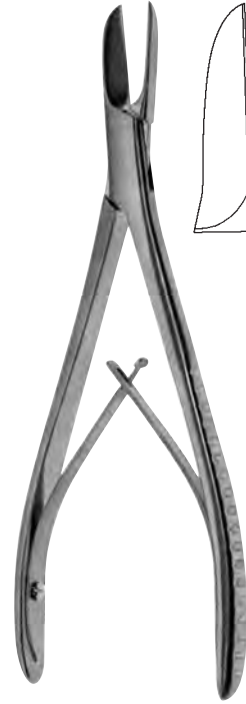

COTTLE-KAZANJIAN

024-932-190 19,0 cm / 7 1/2"

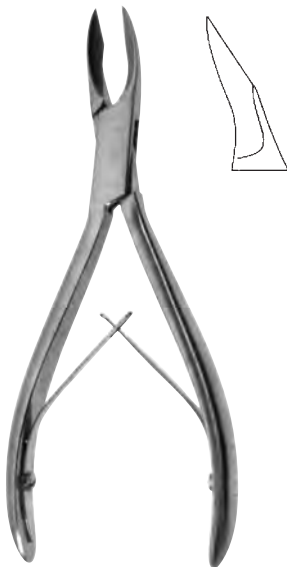

CLEVELAND

024-937-150 15,0 cm / 6"

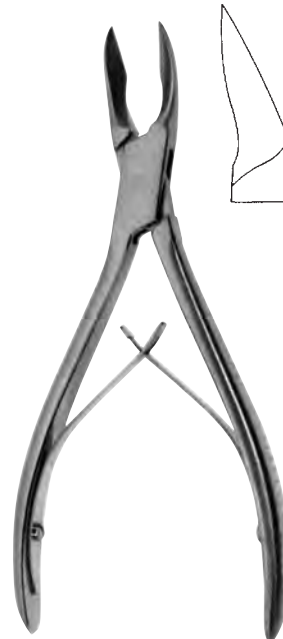

CLEVELAND

024-937-170 17,0 cm / 6 3/4"



BÖHLER
024-938-150 15,0 cm / 6"



BÖHLER
024-939-150 15,0 cm / 6"



RUSKIN
024-940-180 18,0 cm / 7"



RUSKIN
024-941-180 18,0 cm / 7"



MC INDOE
024-943-175 17,5 cm / 6³/₄"



024

Knochensplitterzangen
Bone Cutting Forceps
Pinzas cortantes para huesos
Cesoie per ossa



STILLE-LISTON

024-945-270 27,0 cm / 10³/₄"



STILLE-LISTON

024-948-270 27,0 cm / 10³/₄"



STILLE-LISTON

024-949-240 24,0 cm / 9¹/₂"



STILLE-LISTON

024-949-270 27,0 cm / 10³/₄"



024

Knochensplitterzangen
Bone Cutting Forceps
Pinzas cortantes para huesos
Cesoie per ossa



LISTON-KEY

024-951-270 27,0 cm / 10³/₄"



SEMB

024-953-240 24,0 cm / 9¹/₂"



Bleihände. Durch Umbiegen der Lappen werden Hand und Finger in Operationslage festgehalten und durch das Gewicht der Bleihand zusätzlich immobilisiert.

Lead hands. Hand and fingers are secured by bending the lateral fixation process and further fixed by weight of lead hand.

Manos de plomo. Doblando los lóbulos se sujeta la mano y los dedos en posición para operar y además se queda inmóvil por el peso de la mano de plomo.

Mano di piombo. Legando i lobi, la mano e le dita si assestano in posizione da poter operare grazie al peso della mano di piombo.

024-960-001 24,5 cm / 9³/₄"

für Kinder
for children
para niños
per bambine

024-960-002 37,0 cm / 14¹/₂"

für Erwachsene
for adults
para adultos
per adulti



024

Kompressorium, Fingernagelbohrer
Tourniquet, Finger Nail Drill
Compresor, Perforador para uñas
Compressorio, Perforatore per unghie



024-964-011

Band allein
Band only
Tomo solo
Nastro solo

FELDHEIM

024-964-010 10,0 cm / 4"

Nagelbohrer
finger nail drill
Taladro para uñas
Ghiaccia unghie

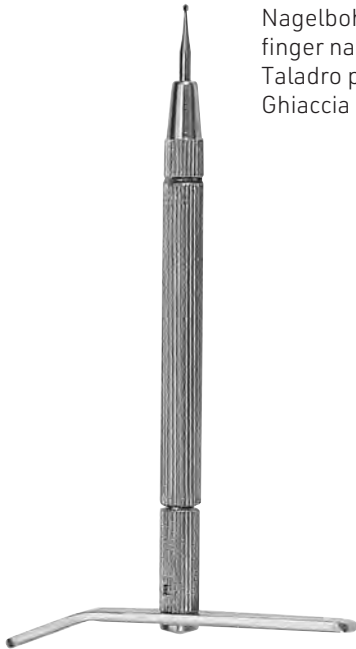

MARTIN-IDEAL

024-966-000
komplett
complet
completo
completo



024-968-001



024-968-002



024-968-003

MARTIN-IDEAL

024-968-030

Satz mit 3 Bohrern
Set of 3 drills
Juego de 3 brocas
Set con 3 punte



024-971-001

Ersatzsägeblatt
 Spare saw black
 Hoja de repuesto para sierra
 Lama di ricambio per sega

MOD. MARTIN

024-970-170 17,0 cm / 6³/₄"



024-973-001

Ersatzsägeblatt
 Spare saw black
 Hoja de repuesto para sierra
 Lama di ricambio per sega

WALTON

024-972-160 16,0 cm / 6¹/₄"



024-976-001

Ersatzsägeblatt
 Spare saw black
 Hoja de repuesto para sierra
 Lama di ricambio per sega

024-975-170 17,0 cm / 6³/₄"

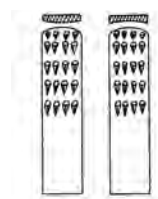

RADOLF

024-978-135 13,5 cm / 5³/₈"



024



025

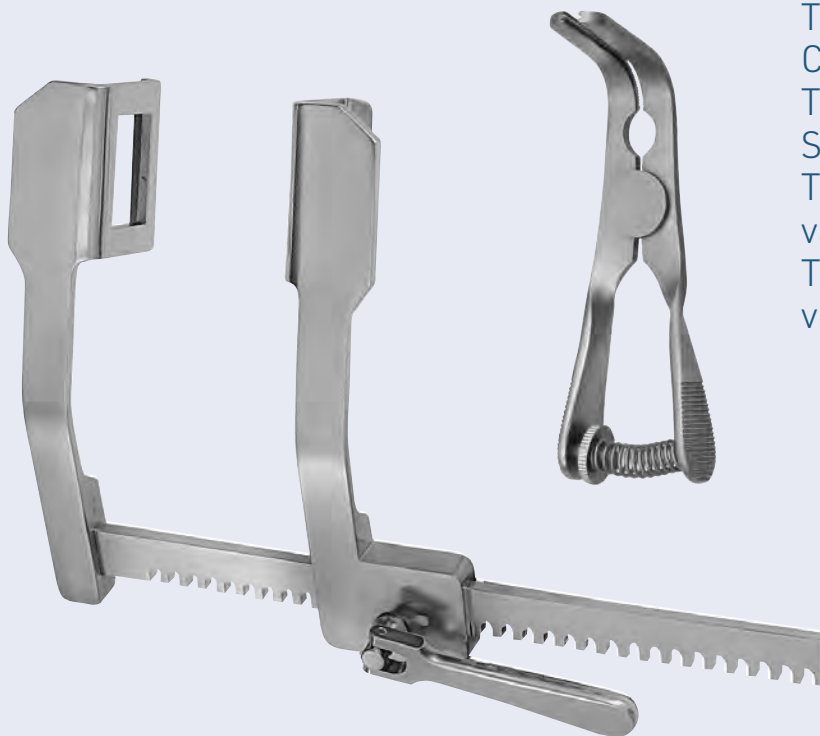

Thorax, Cardiovascular-
Chirurgie
Thorax, Cardiovascular
Surgery
Torácio, Cirugía cardio-
vascular
Torace, Chirurgia cardio-
vascolare



025

Rippenscheren
Rib Shears
Costòtomos
Costotomi



025-100-230 23,0 cm / 9"



025-104-230 23,0 cm / 9"



GLUCK
025-106-220 22,0 cm / 8"

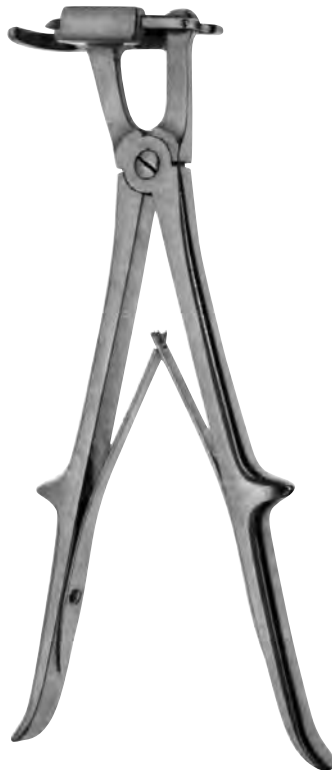

SAUERBRUCH
025-110-260 26,0 cm / 10³/₄"



GIERTZ-STILLE
025-111-270 27,0 cm / 10³/₄"

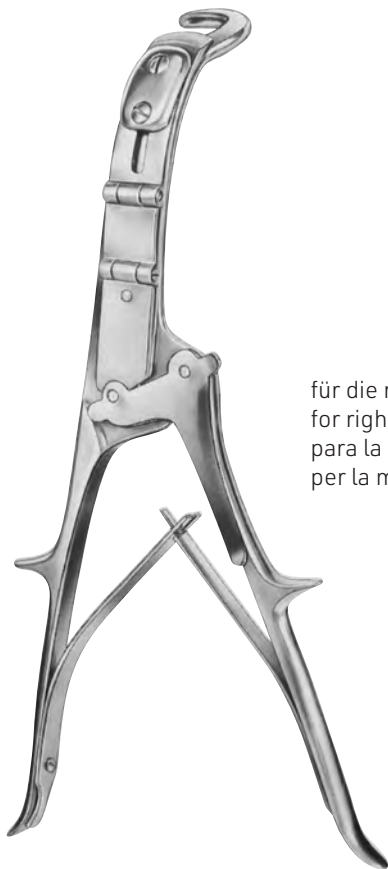

für die rechte Hand
for right hand
para la mano derecha
per la mano destra

BRUNNER
025-113-320 32,0 cm / 12¹/₂"

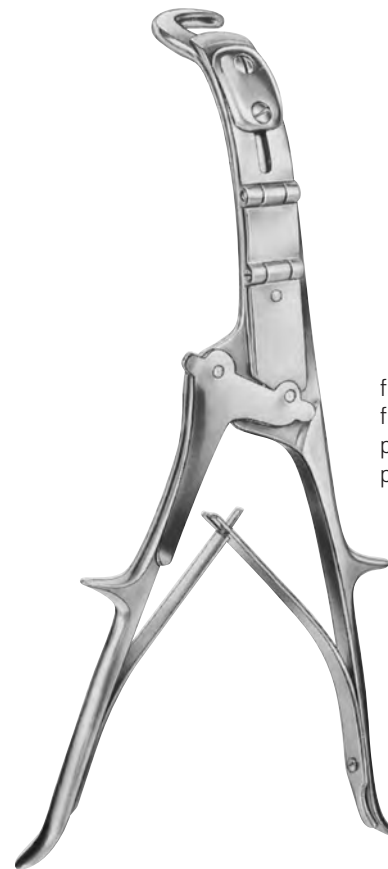

für die linke Hand
for left hand
para la mano izquierda
per la mano sinistra

BRUNNER
025-115-320 32,0 cm / 12¹/₂"



025

Rippenscheren
Rib Shears
Costòtomos
Costotomi



BETHUNE

025-117-340 34,0 cm / 13³/₄"



LEBSCHE

025-119-245 24,5 cm / 10"

ALUMINIUM

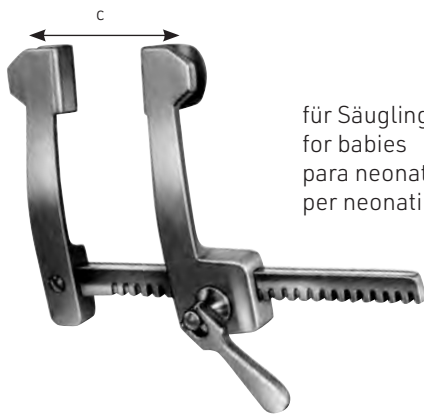
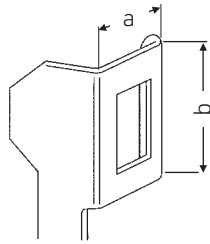

für Säuglinge
 for babies
 para neonatales
 per neonati

COOLEY	a x b	c
025-150-085	12 x 16 mm	85 mm



für Kinder
 for children
 para niños
 per bambini

COOLEY	a x b	c
025-150-115	15 x 30 mm	115 mm



für Erwachsene
 for adults
 para adultos
 per adulti

COOLEY	a x b	c
025-152-140	20 x 45 mm	140 mm
025-152-185	35 x 50 mm	185 mm



025

Rippensperrer
Rib Retractors
Separadores costales
Divaricatori costali

ALUMINIUM

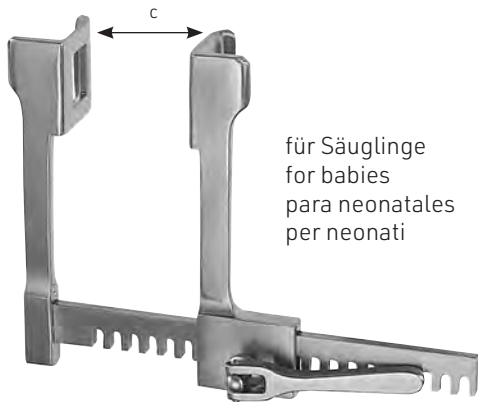

für Säuglinge
for babies
para neonatales
per neonati

FINOCHIETTO BABY	a x b	c
025-160-001	15 x 15 mm	75 mm



für Kinder
for children
para niños
per bambini

FINOCHIETTO INFANT	a x b	c
025-162-001	31 x 31 mm	100 mm

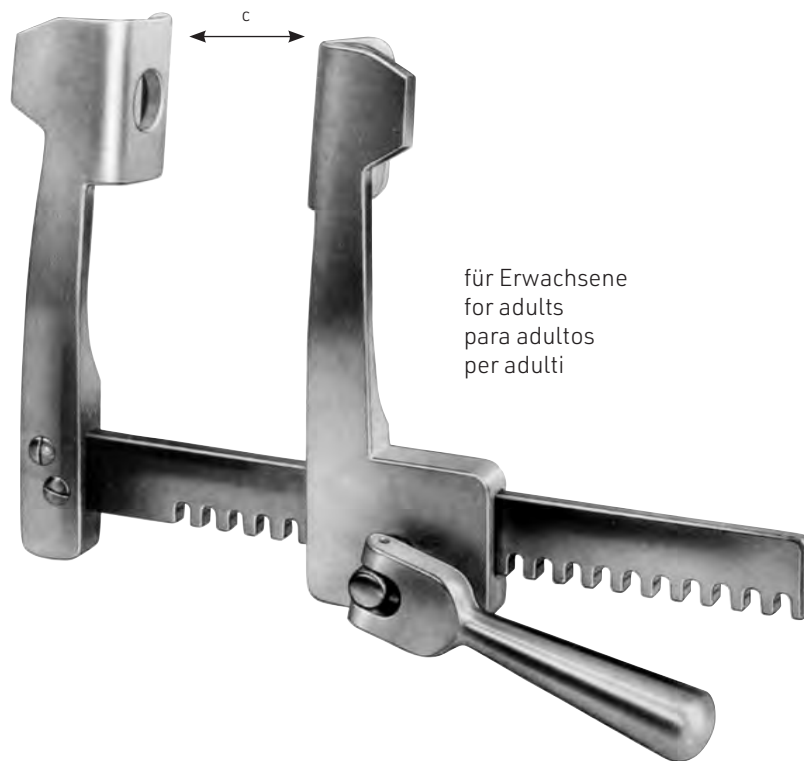

für Erwachsene
for adults
para adultos
per adulti

FINOCHIETTO	a x b	c
025-164-001	40 x 45 mm	135 mm
025-164-002	52 x 62 mm	175 mm
025-164-003	85 x 65 mm	175 mm

ALUMINIUM

025-171-001 34 x 42 mm
 Ersatzvalven, Paar
 Spare blades, pair
 Valvas de recambio, par
 Valve di ricambio, paio

025-171-002 48 x 42 mm
 Ersatzvalven, Paar
 Spare blades, pair
 Valvas de recambio, par
 Valve di ricambio, paio

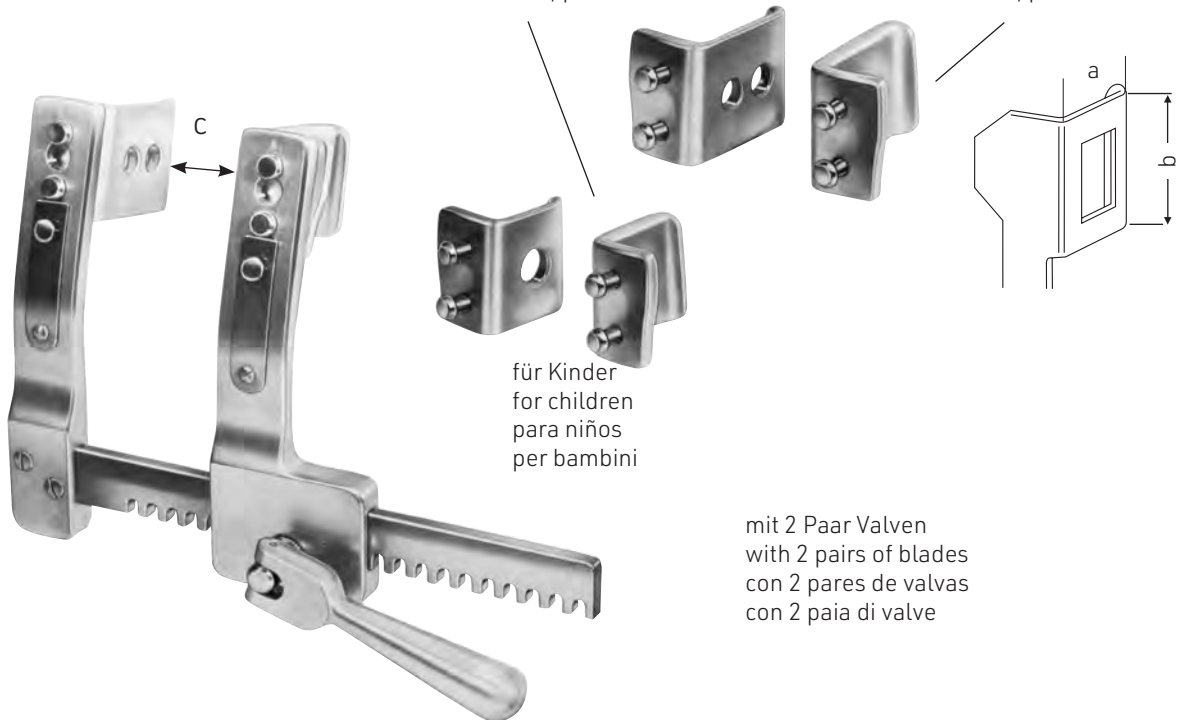

BURFORD	a x b	c
025-170-001	48 x 42 mm + 34 x 42 mm	135 mm

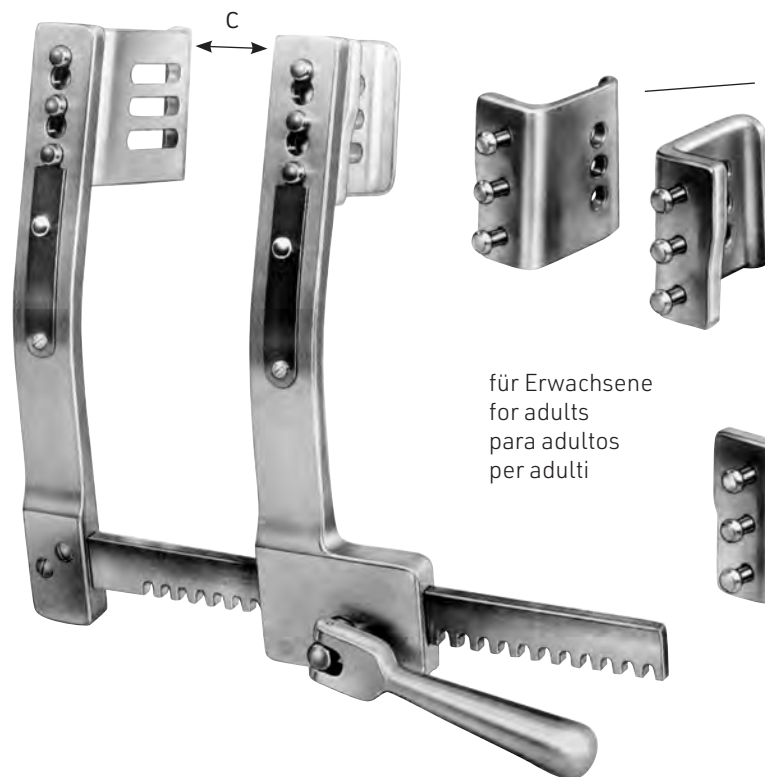

025-173-001 47 x 62 mm
 Ersatzvalven, Paar
 Spare blades, pair
 Valvas de recambio, par
 Valve di ricambio paio

025-173-002 65 x 62 mm
 Ersatzvalven, Paar
 Spare blades, pair
 Valvas de recambio, par
 Valve di ricambio paio

BURFORD	a x b	c
025-172-001	47 x 62 mm + 65 x 62 mm	200 mm
025-172-002	47 x 62 mm + 65 x 62 mm	260 mm
025-172-003	47 x 62 mm + 65 x 62 mm	300 mm



025

Rippensperrer
Rib Retractors
Separadores costales
Divaricatori costali

ALUMINIUM

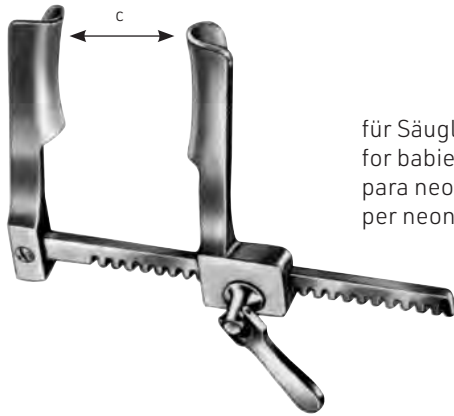
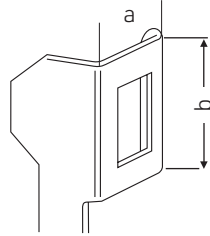

für Säuglinge
for babies
para neonatales
per neonati

CASTAÑEDA	a x b	c
025-180-001	10,5 x 32 mm	65 mm



für Kleinkinder
for infants
para bebes
per piccoli

CASTAÑEDA	a x b	c
025-180-002	12 x 45 mm	70 mm



für Kinder
for children
para niños
per bambini

CASTAÑEDA	a x b	c
025-180-003	15 x 60 mm	120 mm

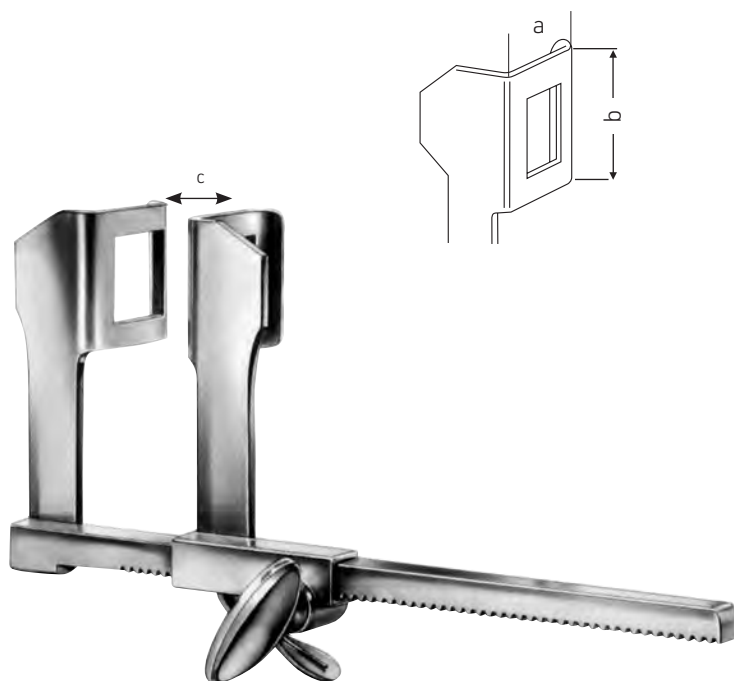

HAIGHT	a x b	c
025-184-001	30 x 30 mm	120 mm



TUFFIER	a x b	c
025-186-001	45 x 45 mm	160 mm



025

Rippensperrer
Rib Retractors
Separadores costales
Divaricatori costali

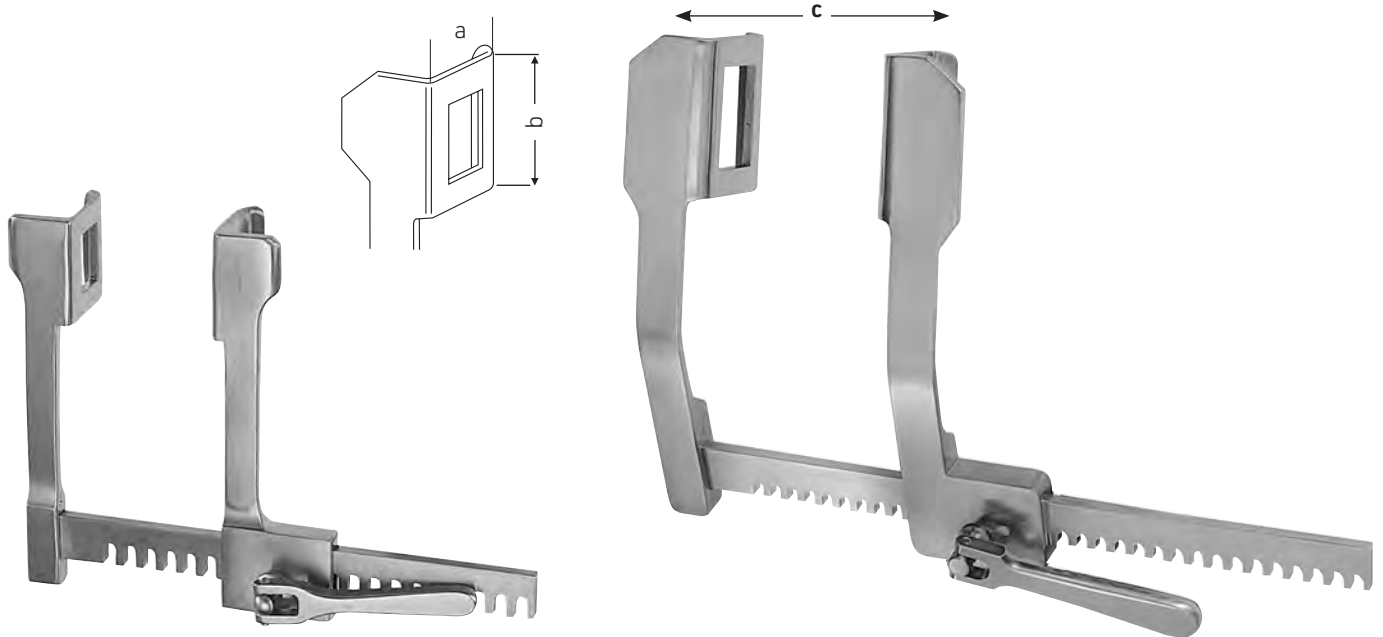

FINOCHIETTO BABY	a x b	c
025-190-001	14 x 15 mm	75 mm

FINOCHIETTO	a x b	c
025-192-001	40 x 40 mm	165 mm
025-192-002	45 x 65 mm	200 mm
025-192-003	70 x 65 mm	250 mm



ALUMINIUM

FINOCHIETTO (MODIF.)	a x b	c
025-194-001	14 x 15 mm	120 mm

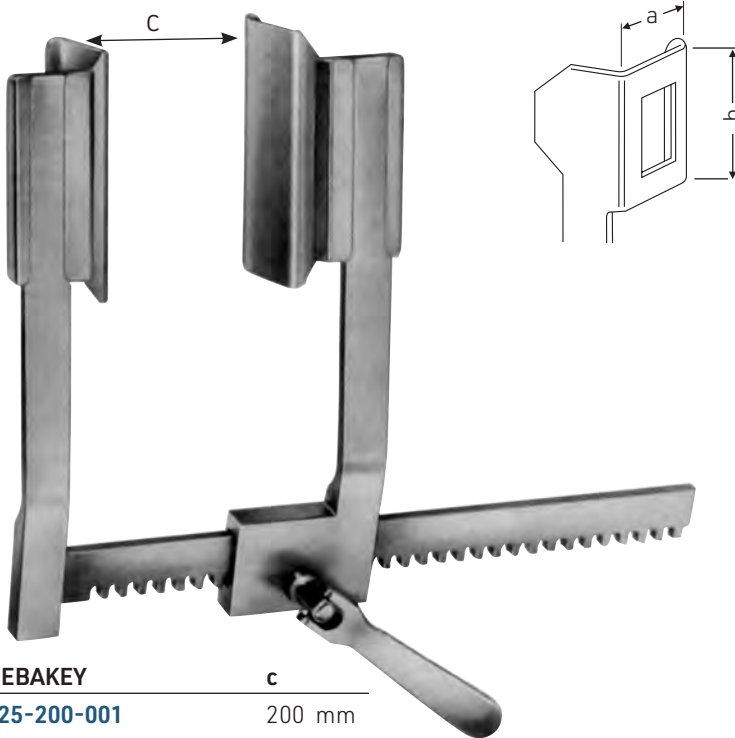

DEBAKEY

025-200-002

Sperrer allein
 Retractor only
 Separador suelto
 Divaricatore solo

DEBAKEY
025-200-001 c
200 mm



025-201-001 60 x 60 mm



025-201-002 50 x 80 mm



025-201-003 40 x 100 mm

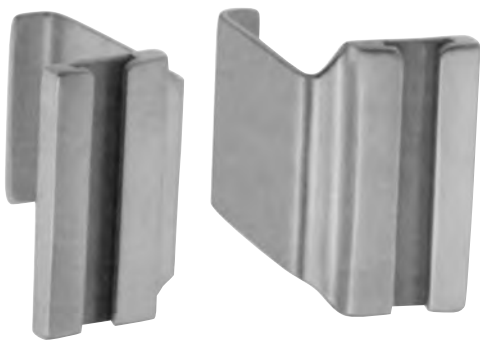

025-201-004 80 x 60 mm



025-201-005 50 x 66 mm



025

Rippensperrer
Rib Retractors
Separadores costales
Divaricatori costali

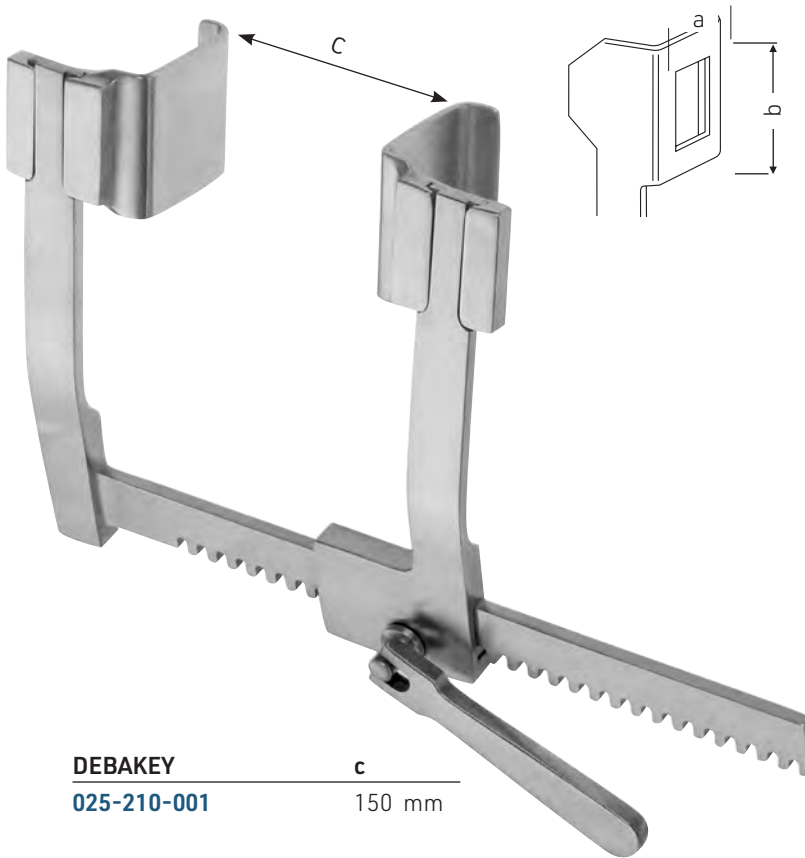

DEBAKEY
025-210-001 **c**
150 mm

DEBAKEY

025-210-002

Sperrer allein
Retractor only
Separador suelto
Divaricatore solo



025-211-001 30 x 30 mm



025-211-002 40 x 40 mm

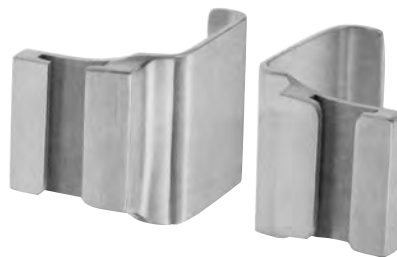

025-211-003 50 x 50 mm

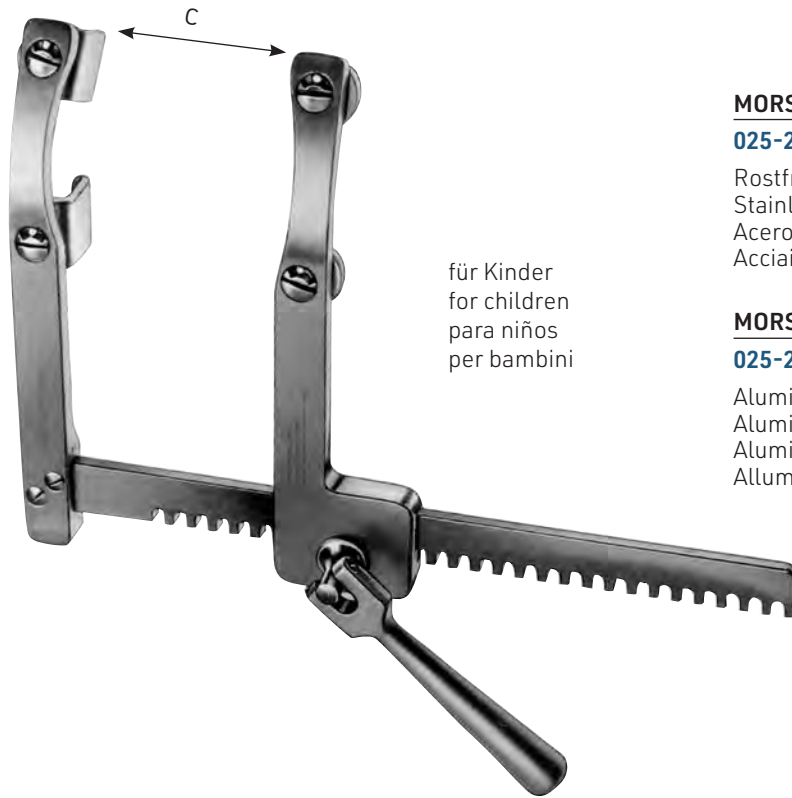

für Kinder
 for children
 para niños
 per bambini

MORSE-FAVALORO	a x b	c
025-220-001	17 x 22 mm	160 mm

Rostfreier Stahl
 Stainless Steel
 Acero inoxidable
 Acciaio inossidabile

MORSE-FAVALORO	a x b	c
025-224-001	17 x 22 mm	160 mm

Aluminium
 Aluminium
 Aluminio
 Alluminio

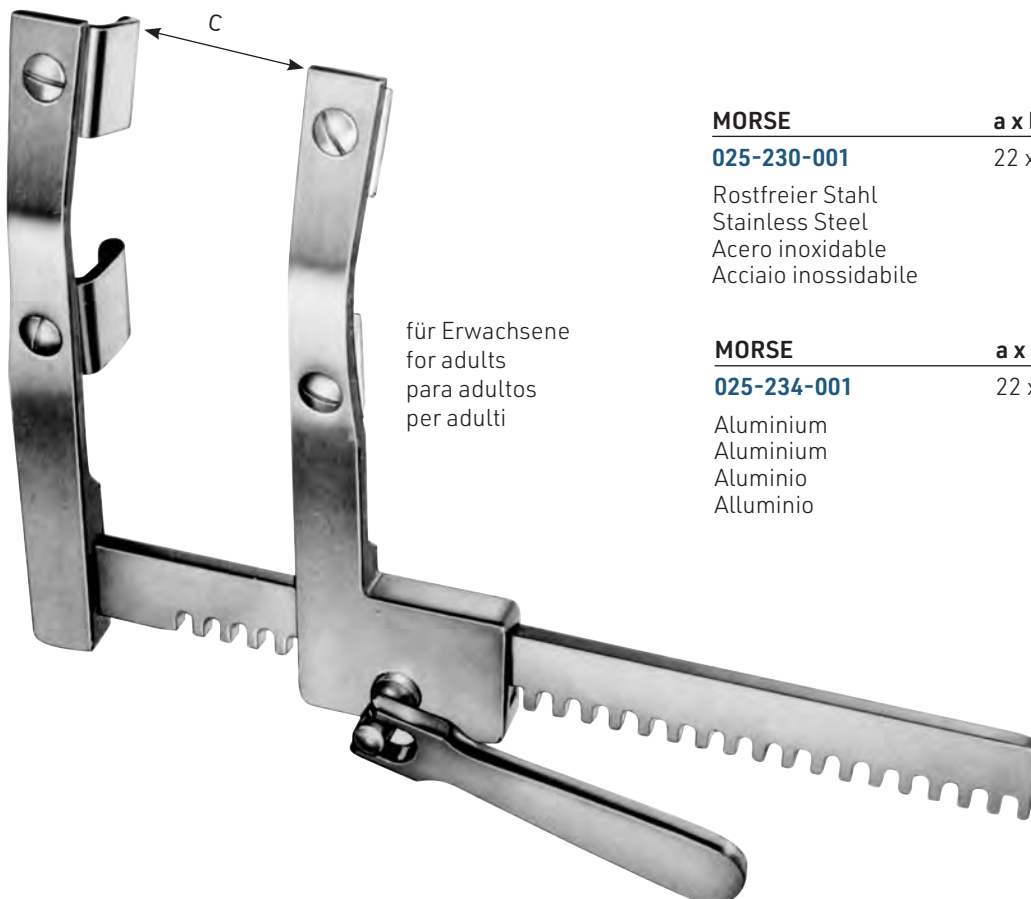

für Erwachsene
 for adults
 para adultos
 per adulti

MORSE	a x b	c
025-230-001	22 x 27 mm	200 mm

Rostfreier Stahl
 Stainless Steel
 Acero inoxidable
 Acciaio inossidabile

MORSE	a x b	c
025-234-001	22 x 27 mm	200 mm

Aluminium
 Aluminium
 Aluminio
 Alluminio



025

Thoraxsperrer
Thoracic Retractor
Separador torácico
Divaricatore per il torace



MERCEDES

025-240-001

komplett
complete
completo
completo

MERCEDES

025-240-002

Sperrer allein
Retractor only
Separador suelto
Divaricatore solo



025-241-001

48 x 68 mm

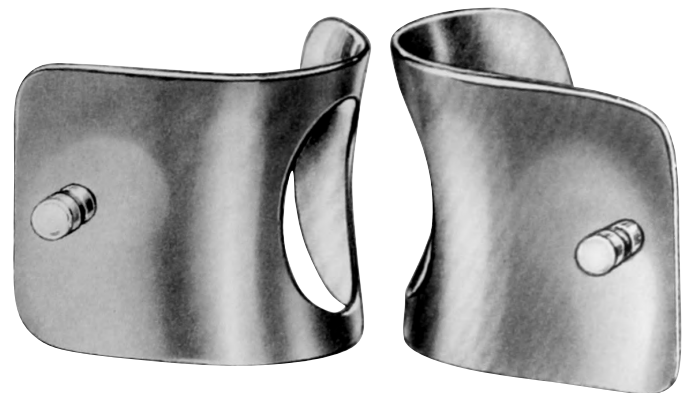

025-241-002

70 x 75 mm



BABY-BAILEY
025-252-155 15,5 cm / 6"



BAILEY
025-254-200 20,0 cm / 8"



BAILEY-GIBBON
025-256-200 20,0 cm / 8"



025

Lungenspatel
Lung Spatulas
Espátulas pulmonares
Spatole per pulmone



ALLISON

025-261-300 30,0 cm / 11³/₄" 40 mm
025-261-320 32,0 cm / 12¹/₂" 54 mm



PRICE-THOMAS

025-271-220 22,0 cm / 8³/₄"



PRICE-THOMAS

025-273-220 - 025-275-220 22,0 cm / 8³/₄"

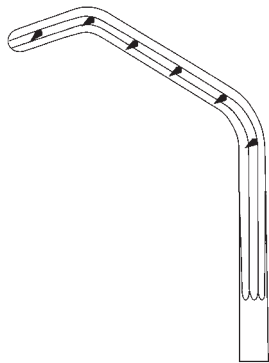

025-273-220

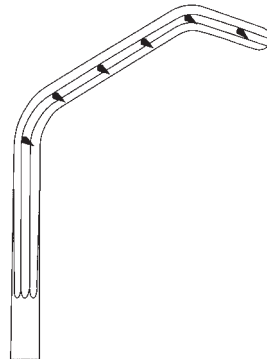

025-275-220

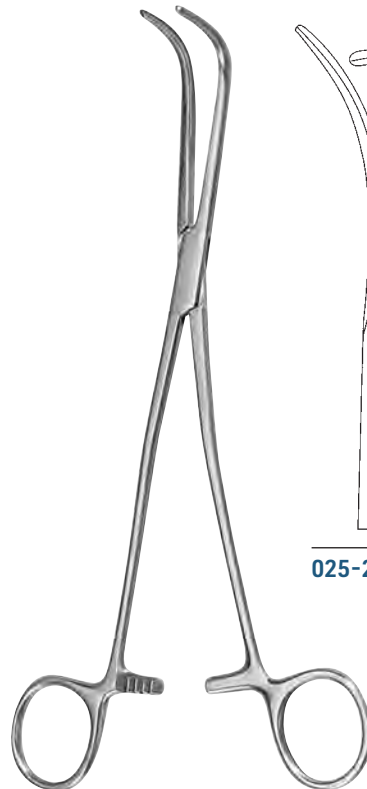

SEMB

025-277-001 - 025-277-002 24,0 cm / 9¹/₂"

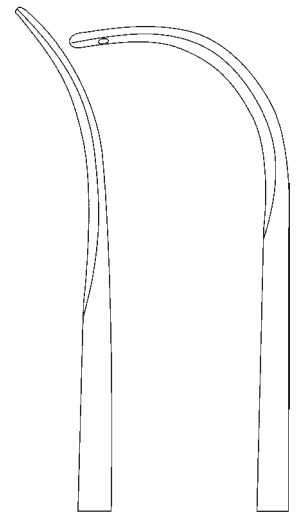

025-277-001

025-277-002



LOVELACE
 025-278-200 20,0 cm / 8"



LOVELACE
 025-279-200 20,0 cm / 8"

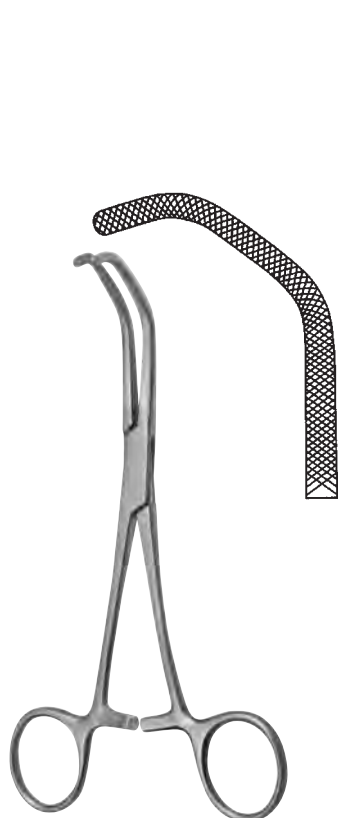

BABY-SATINSKY
 025-281-150 15,0 cm / 6"



SATINSKY
 025-283-001 - 025-283-02 26,5 cm / 10½"

025-283-001

025-283-002



025

Klemmen
Clamps
Pinzas
Pinze

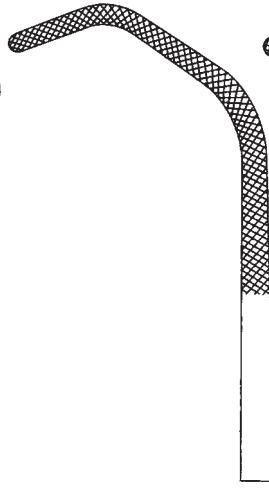

025-285-001

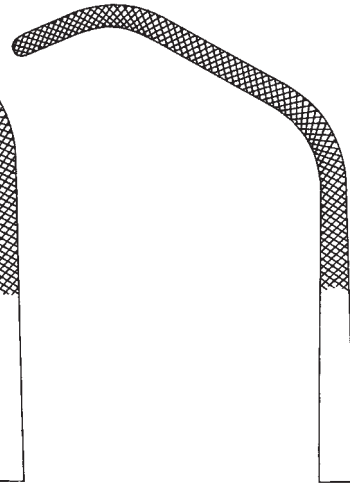

025-285-002

SATINSKY

025-285-001 - 025-285-002

26,5 cm / 10 1/2"

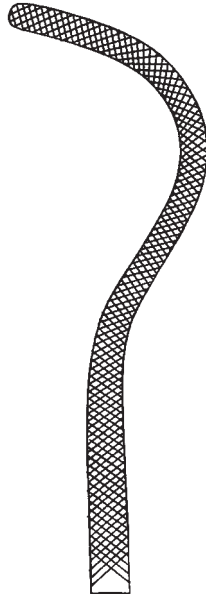

025-289-001

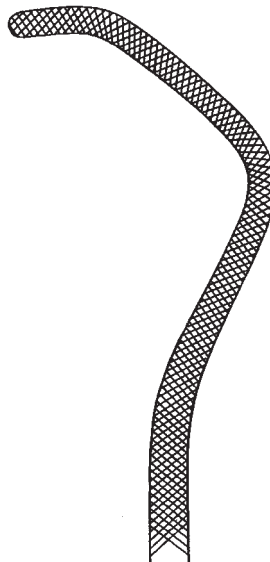

025-289-002

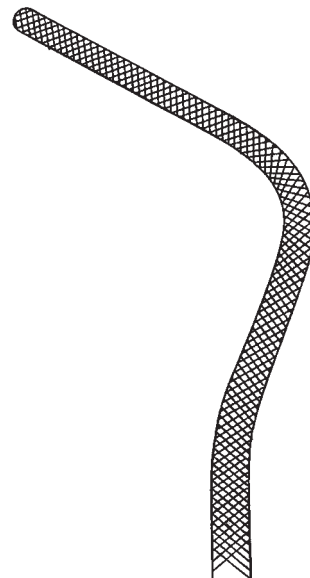

025-289-003

HARKEN

025-289-001 - 025-289-003

24,0 cm / 9 1/2"

ATRAUMA

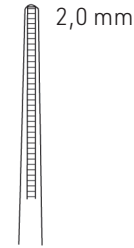
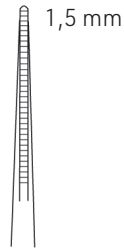

025-300-160 16,0 cm / 6¹/₄"
025-300-200 20,0 cm / 8"
025-300-240 24,0 cm / 9¹/₂"

025-302-160 16,0 cm / 6¹/₄"
025-302-200 20,0 cm / 8"
025-302-240 24,0 cm / 9¹/₂"
025-302-300 30,0 cm / 12"

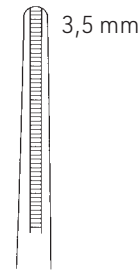
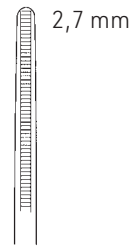

025-304-160 16,0 cm / 6¹/₄"
025-304-200 20,0 cm / 8"
025-304-240 24,0 cm / 9¹/₂"
025-304-300 30,0 cm / 12"

025-306-160 16,0 cm / 6¹/₄"
025-306-200 20,0 cm / 8"
025-306-240 24,0 cm / 9¹/₂"
025-306-300 30,0 cm / 12"

DEBAKEY

025-300-160 - 025-306-300

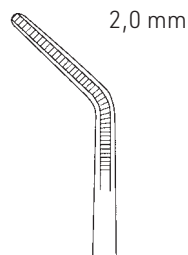

025-309-160 16,0 cm / 6¹/₄"
025-309-200 20,0 cm / 8"
025-309-240 24,0 cm / 9¹/₂"
025-309-300 30,0 cm / 12"

DEBAKEY

025-309-160 - 025-309-300



025

Klemmen mit DEBAKEY-Zahnung
Clamps with Toothing DEBAKEY
Clamps con dentado DEBAKEY
Pinze con dentatura DEBAKEY

ATRAUMA



DEBAKEY

025-320-075	7,5 cm / 3"
025-320-085	8,5 cm / 3 1/4"
025-320-105	10,5 cm / 4 1/8"
025-320-120	12,0 cm / 4 3/4"

L

2,5 cm / 1"
3,5 cm / 1 3/8"
5,0 cm / 2"
6,8 cm / 2 3/4"



DEBAKEY

025-321-070	7,5 cm / 3"
025-321-080	8,5 cm / 3 3/8"
025-321-100	9,5 cm / 3 3/4"
025-321-115	11,0 cm / 4 3/8"

L

2,5 cm / 1"
3,5 cm / 1 3/8"
5,0 cm / 2"
6,8 cm / 2 3/4"

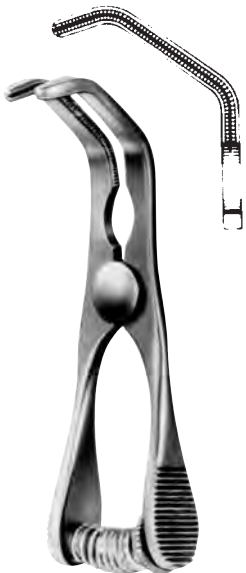

DEBAKEY-SATINSKY

025-323-070	7,0 cm / 2 3/4"
--------------------	-----------------



DEBAKEY-SATINSKY

025-325-090	9,0 cm / 3 1/2"
--------------------	-----------------



DEBAKEY-SATINSKY

025-327-100	10,0 cm / 4"
--------------------	--------------

ATRAUMA



025-329-235 23,5 cm / 9¹/₄"



GLOVER

025-330-060	6,0 cm / 2 ³ / ₈ "
025-330-070	7,0 cm / 2 ³ / ₄ "
025-330-090	9,0 cm / 3 ³ / ₄ "
025-330-110	11,0 cm / 4 ³ / ₈ "



GLOVER

025-331-055	5,5 cm / 2 ¹ / ₃ "
025-331-070	7,0 cm / 2 ¹ / ₂ "
025-331-085	8,5 cm / 3 ¹ / ₂ "
025-331-105	10,5 cm / 4 ³ / ₈ "



025

Klemmen mit DEBAKEY-Zahnung
Clamps with Toothing DEBAKEY
Clamps con dentado DEBAKEY
Pinze con dentatura DEBAKEY

ATRAUMA



GLOVER

025-333-060

6,0 cm / 2 1/4"



SANTULLI

025-335-070

7,0 cm / 2 3/4"

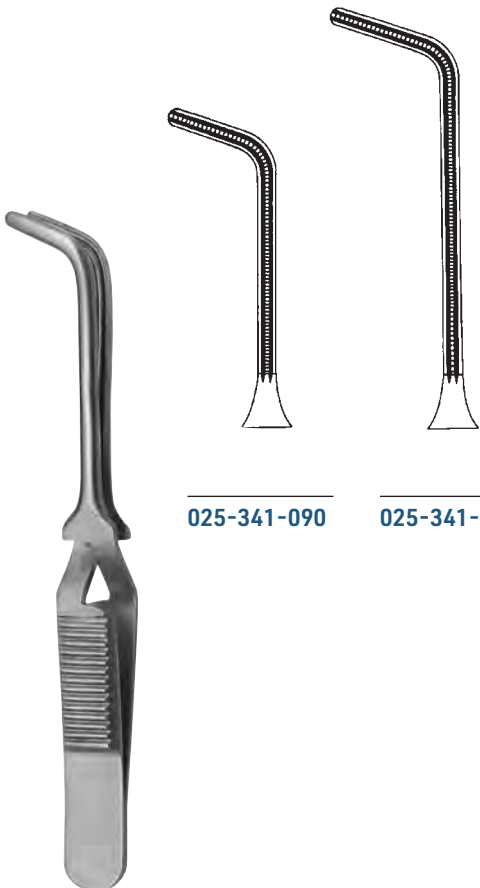

025-341-090

025-341-110

GREGORY SOFT

025-341-090 9,0 cm / 3 1/2"

025-341-110 11,0 cm / 4 1/4"



025-343-105

rechts
right
derecho
destro

025-345-105

links
left
izquierdo
sinistro

GREGORY

025-343-105 - 025-345-105

10,5 cm / 4"

ATRAUMA



MOSQUITO-DEBAKEY

025-350-125 - 025-351-125

12,5 cm / 5"



025-350-125



025-351-125



MOSQUITO-DEBAKEY

025-350-150 - 025-351-150



025-350-150



025-351-150

15,0 cm / 6"

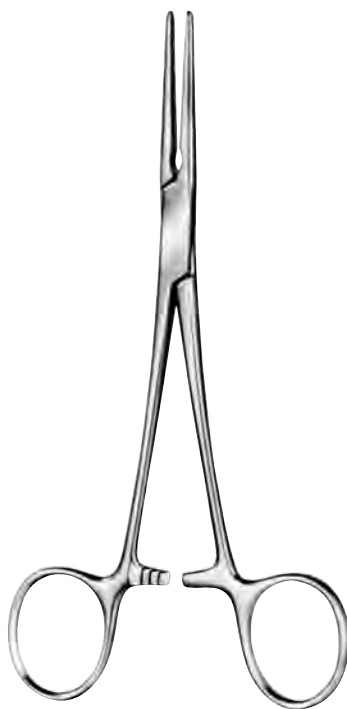

DE-BAKEY-RANKIN

025-354-160 - 025-355-160



025-354-160



025-355-160

16,0 cm / 6 1/4"



025

Klemmen mit DEBAKEY-Zahnung
Clamps with Toothing DEBAKEY
Pinzas-clamps con dentado DEBAKEY
Pinze con dentatura DEBAKEY

ATRAUMA



PEAN-DEBAKEY
025-360-145 - 025-360-205



025-360-145
14,5 cm / 5³/₄"

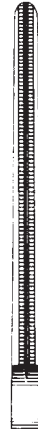

025-360-165
16,5 cm / 6¹/₂"

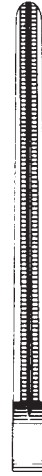

025-360-185
18,5 cm / 7¹/₄"

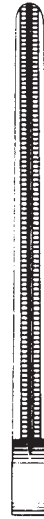

025-360-205
20,5 cm / 8"

ATRAUMA



PEAN-DEBAKEY

025-361-145 - 025-361-205

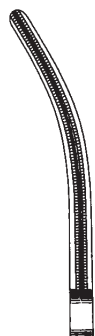

025-361-145
14,5 cm / 5³/₄"

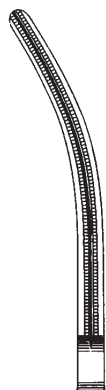

025-361-165
16,5 cm / 6¹/₂"

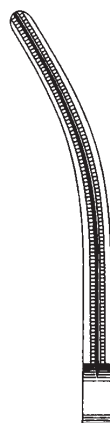

025-361-185
18,5 cm / 7¹/₄"

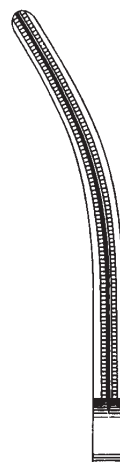

025-361-205
20,5 cm / 8"



025

Klemmen mit DEBAKEY-Zahnung
Clamps with Toothing DEBAKEY
Pinzas-clamps con dentado DEBAKEY
Pinze con dentatura DEBAKEY



025-370-150
15,0 cm / 6"



025-370-185
18,5 cm / 7 1/4"

BAINBRIDGE
025-370-150 - 025-370-185

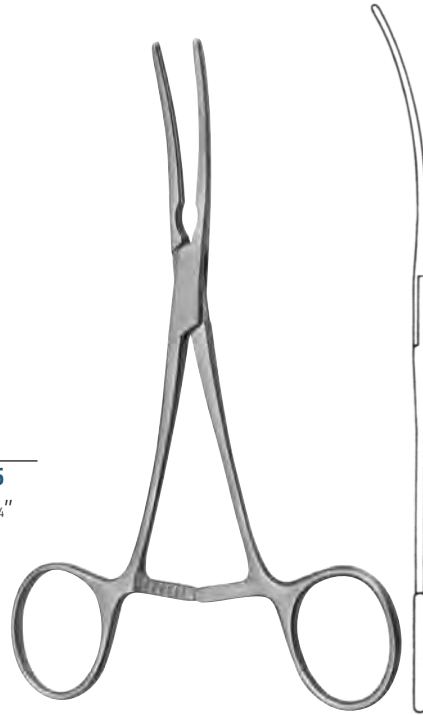

BAINBRIDGE
025-371-150 - 025-371-185

ATRAUMA



025-371-150
15,0 cm / 6"



025-371-185
18,5 cm / 7 1/4"



025-380-210
21,0 cm / 8 1/4"



025-380-225
22,5 cm / 8 3/4"

POTTS
025-380-210 - 025-380-225

ATRAUMA

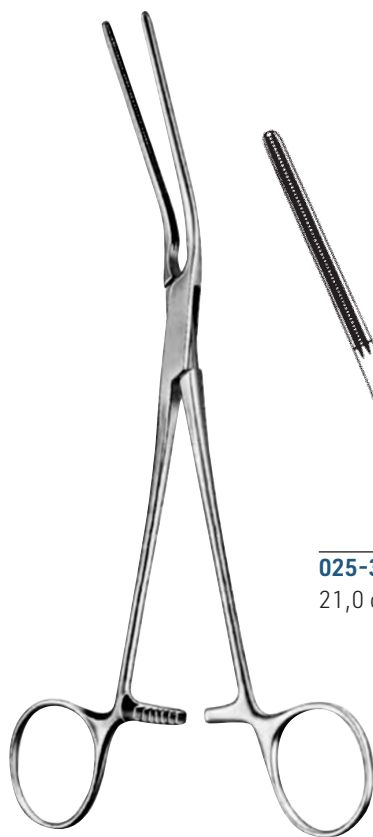

025-381-210
21,0 cm / 8¹/₄"

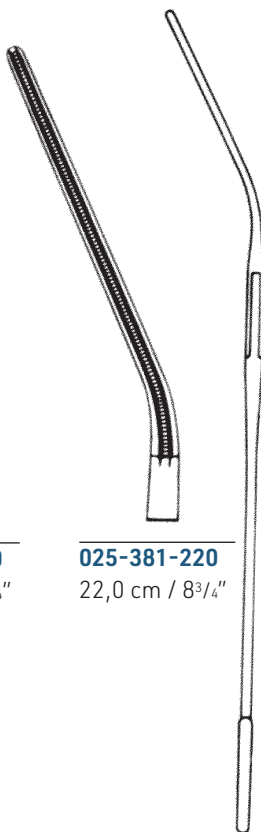

025-381-220
22,0 cm / 8³/₄"

POTTS

025-381-210 - 025-381-220



POTTS

025-383-210 - 025-383-220

025-383-210
21,0 cm / 8¹/₄"

025-383-220
22,0 cm / 8³/₄"

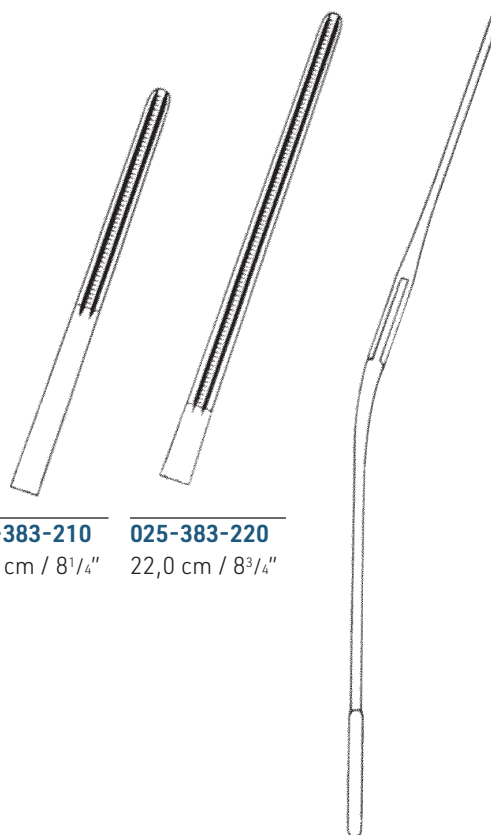



025

Klemmen mit DEBAKEY-Zahnung
Clamps with Toothing DEBAKEY
Pinzas-clamps con dentado DEBAKEY
Pinze con dentatura DEBAKEY

ATRAUMA



POTTS-GLOVER

025-385-215

21,5 cm / 8 1/2"



POTTS

025-387-220

22,0 cm / 2 3/4"

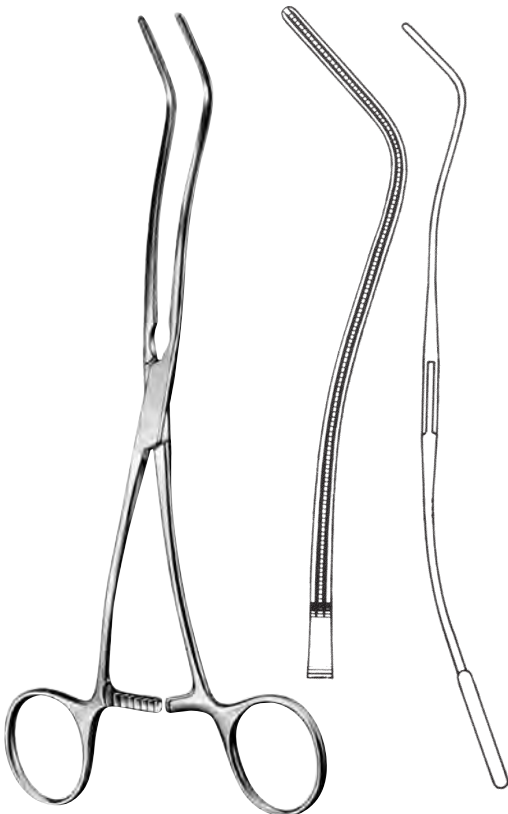

DEBAKEY

025-391-200

20,0 cm / 8"

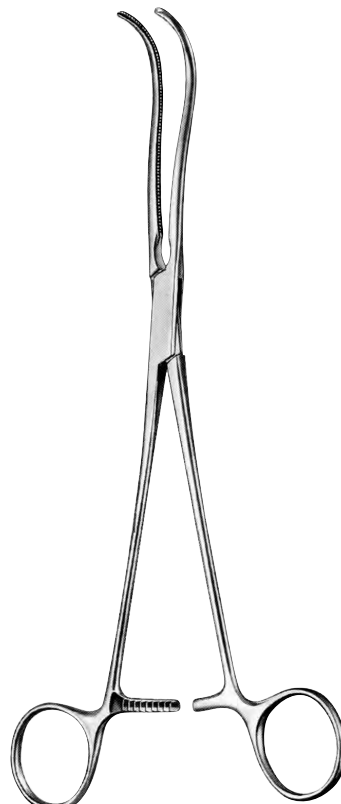

DEBAKEY

025-395-190 - 025-395-240

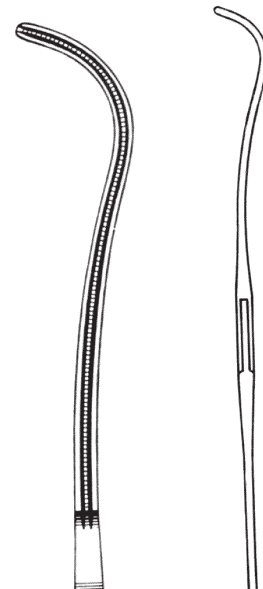

025-395-190

19,0 cm / 7 1/2"

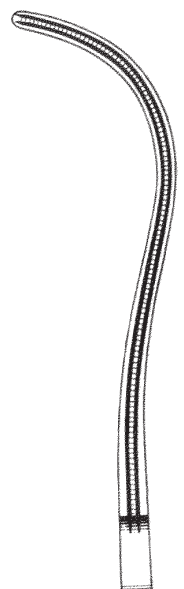

025-395-240

24,0 cm / 9 1/2"

ATRAUMA



DEBAKEY

025-401-160

16,0 cm / 6¹/₄"



DEBAKEY

025-403-190

19,0 cm / 7¹/₂"



DEBAKEY

025-405-200

20,0 cm / 8"



025

Klemmen mit DEBAKEY-Zahnung
Clamps with Toothing DEBAKEY
Pinzas-clamps con dentado DEBAKEY
Pinze con dentatura DEBAKEY

ATRAUMA



LELAND-JONES
025-411-180 18,0 cm / 7"

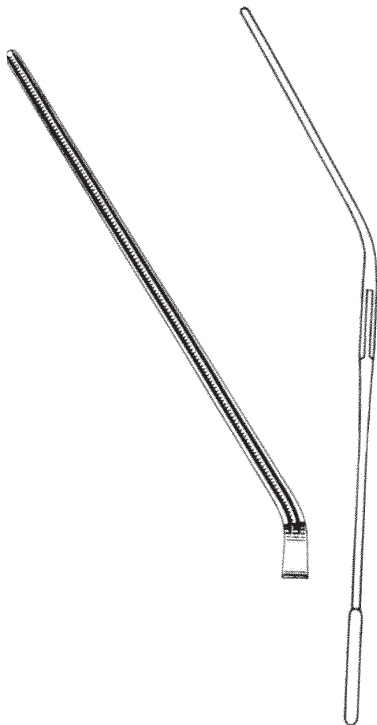
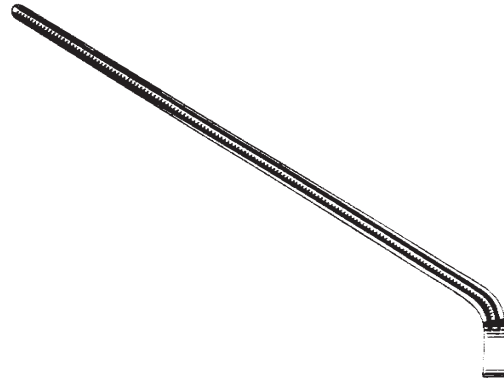

LELAND-JONES
025-411-190 19,0 cm / 7 1/2"

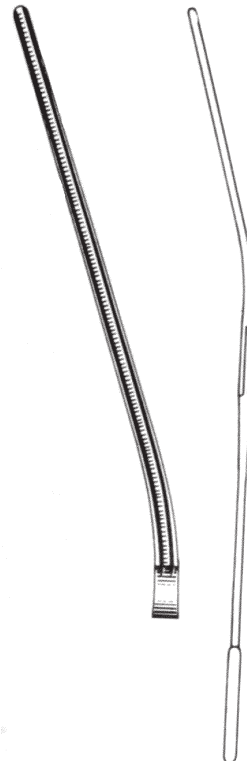

LELAND-JONES
025-411-200 20,0 cm / 8"

ATRAUMA



025-421-260
26,0 cm / 10¹/₄"

025-421-270
27,0 cm / 10³/₄"

025-421-310
31,0 cm / 12¹/₄"

025-421-330
33,0 cm / 13,0"

DEBAKEY

025-421-260 - 025-421-330



025

Klemmen mit DEBAKEY-Zahnung
Clamps with Toothing DEBAKEY
Pinzas-clamps con dentado DEBAKEY
Pinze con dentatura DEBAKEY

ATRAUMA

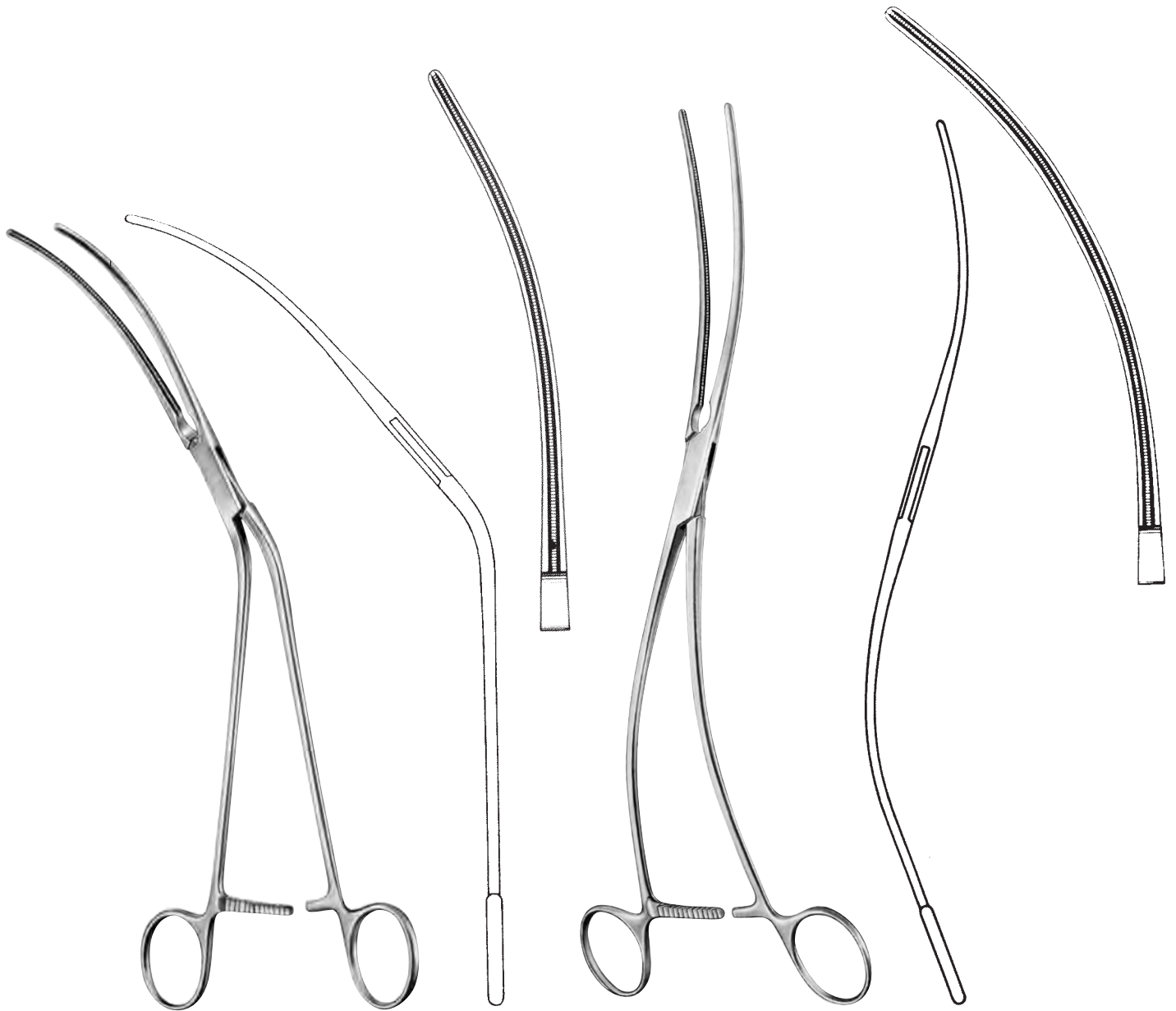

DEBAKEY

025-423-280

28,0 cm / 11"

DEBAKEY

025-425-300

30,0 cm / 11³/₄"

ATRAUMA

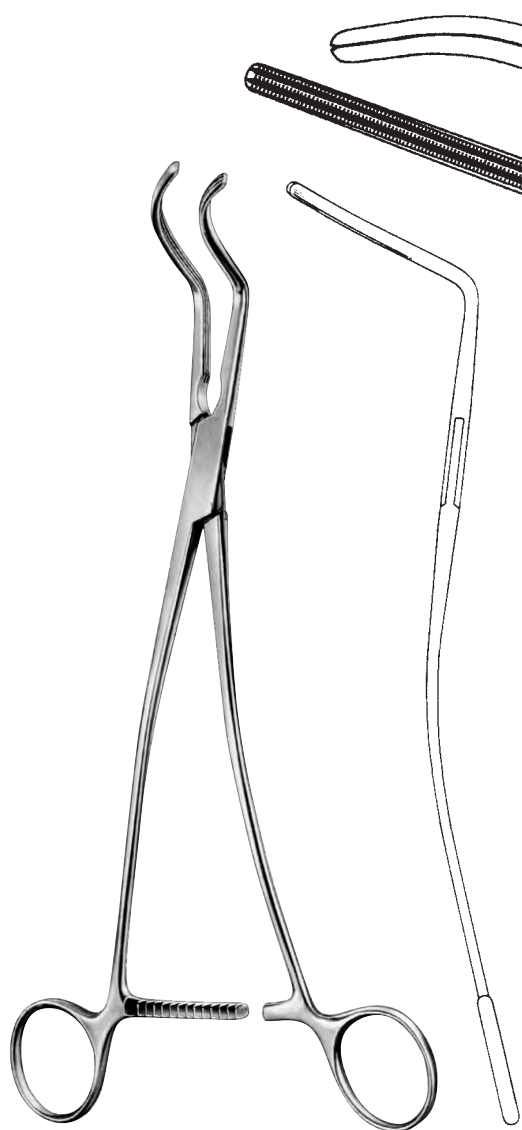

DEBAKEY

025-427-270

27,0 cm / 10³/₄"

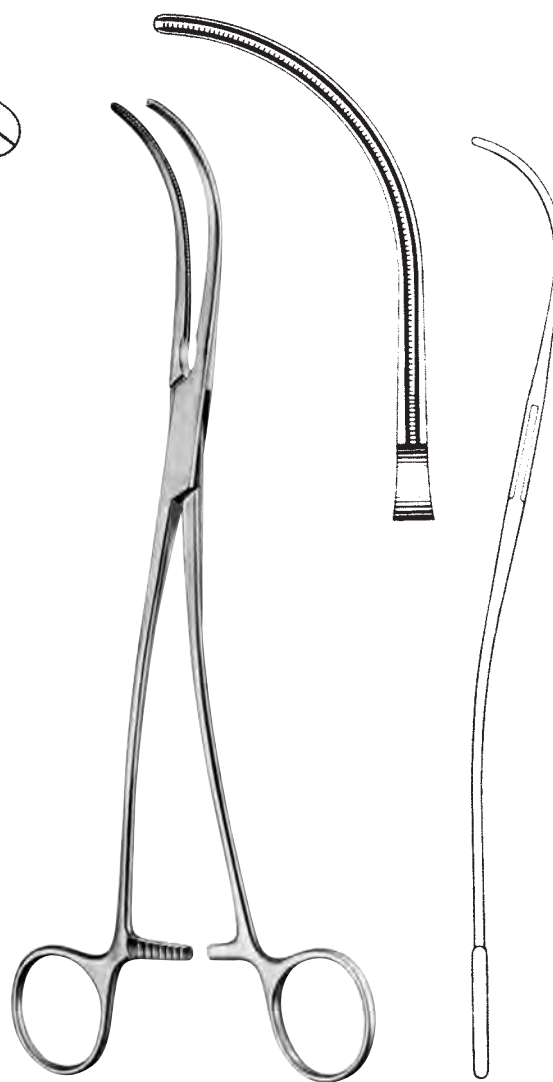

DEBAKEY

025-429-245

24,5 cm / 9³/₄"



025

Klemmen mit DEBAKEY-Zahnung
Clamps with Toothing DEBAKEY
Pinzas-clamps con dentado DEBAKEY
Pinze con dentatura DEBAKEY

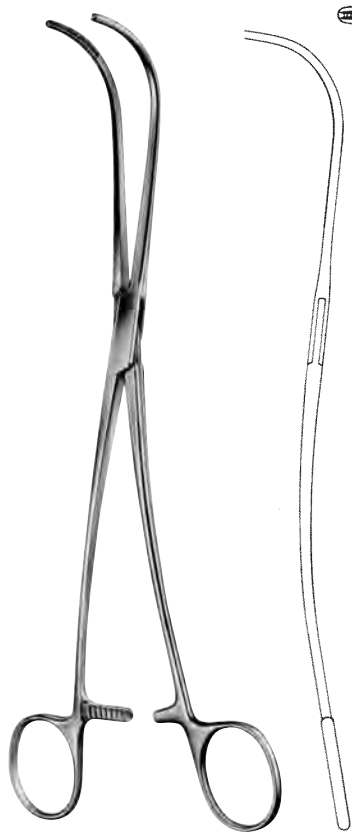

DEBAKEY

025-431-245

24,5 cm / 9³/₄"

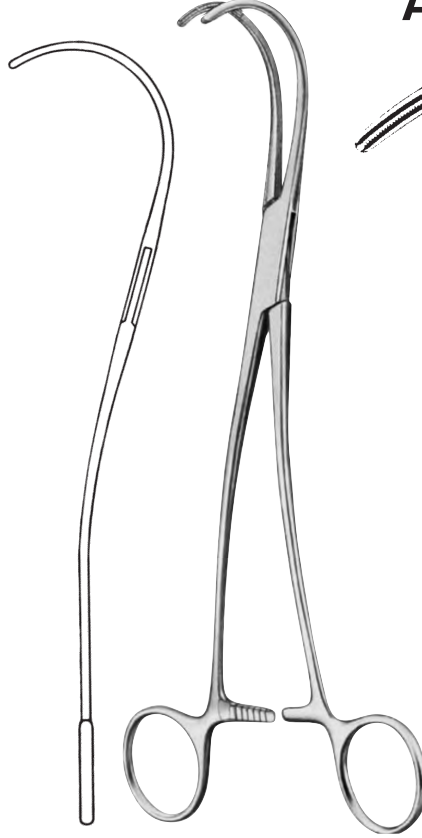
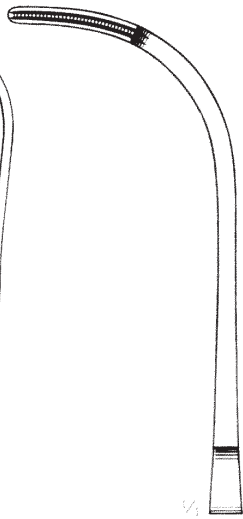

DEBAKEY

025-433-270

27,0 cm / 10¹/₂"

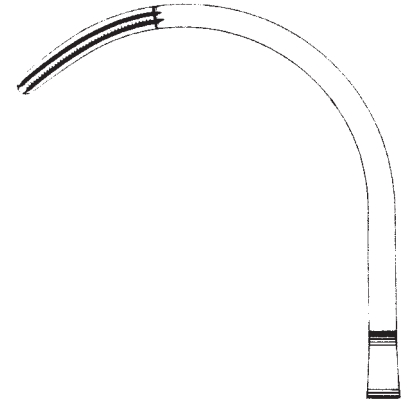

ATRAUMA

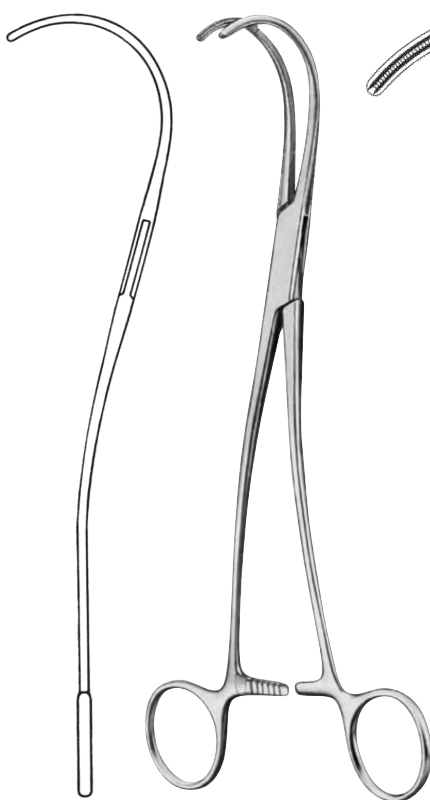

DEBAKEY

025-435-270

27,0 cm / 10¹/₂"

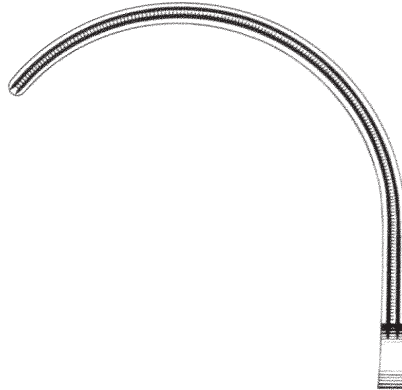

ATRAUMA



WEBER
025-441-001 24,0 cm / 9 1/2''



WEBER
025-441-002 24,0 cm / 9 1/2''



025

Klemmen mit DEBAKEY-Zahnung
Clamps with Toothing DEBAKEY
Pinzas-clamps con dentado DEBAKEY
Pinze con dentatura DEBAKEY

ATRAUMA



025-451-220 22,0 cm / 8³/₄"



025-451-260 26,0 cm / 10¹/₄"



025-451-265 26,5 cm / 10¹/₂"



SATINSKY

025-451-220 - 025-451-285

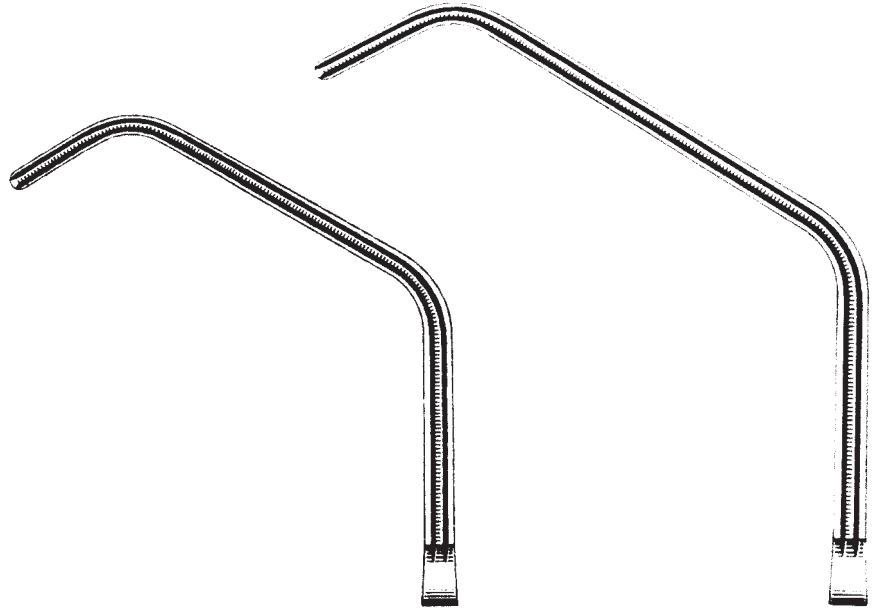

025-451-275 27,5 cm / 10³/₄"

025-451-285 28,5 cm / 11¹/₄"

ATRAUMA

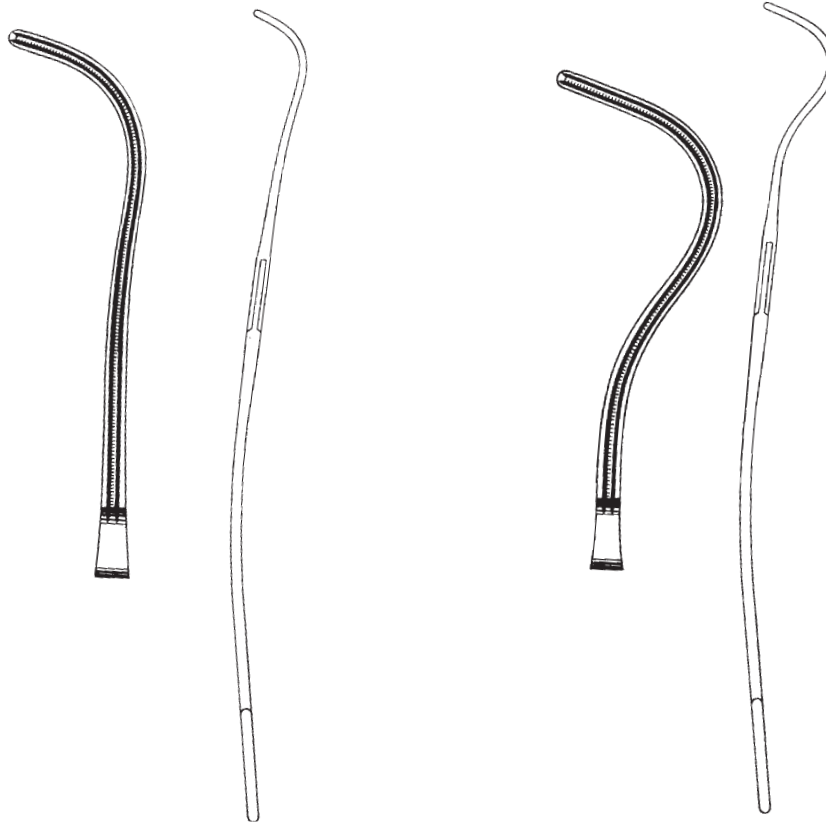

025-461-001 24,5 cm / 9³/₄"

025-461-002 24,0 cm / 9¹/₂"



HARKEN

025-461-001 - 025-461-004



025-461-003 23,0 cm / 9"

025-461-004 23,5 cm / 9¹/₄"



025

Klemmen mit DEBAKEY-Zahnung
Clamps with Toothing DEBAKEY
Pinzas-clamps con dentado DEBAKEY
Pinze con dentatura DEBAKEY

ATRAUMA



LEES

025-471-230 - 025-471-255

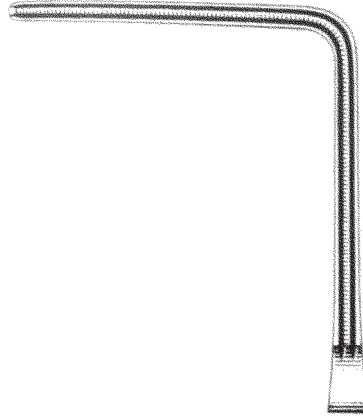
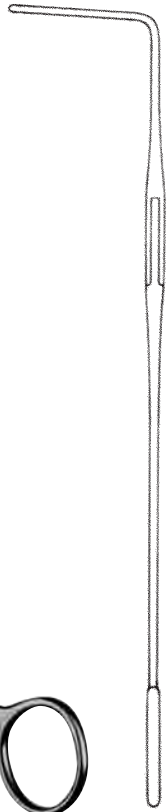

025-471-230 23,0 cm / 9"

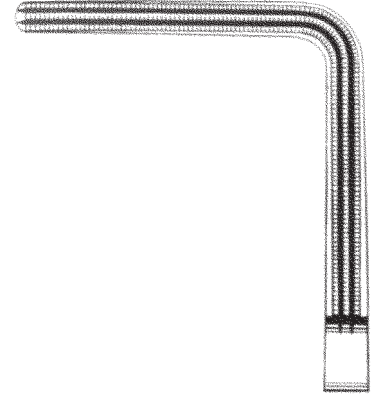

025-471-255 25,5 cm / 10"



LEES

025-473-250 25,0 cm / 9³/₄"

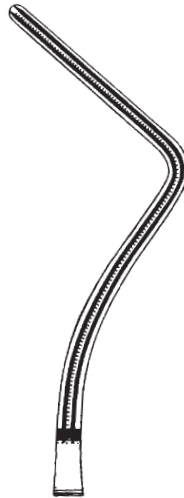

ATRAUMA



LAMBERT-KAY

025-481-001 - 025-481-002 22,5 cm / 8³/₄"



025-481-001

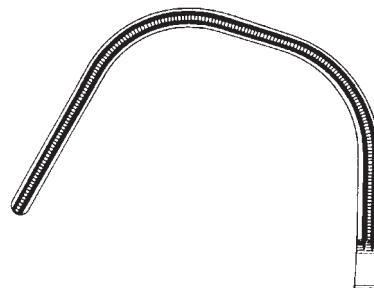

025-481-002



DEBAKEY

025-491-170 17,0 cm / 6³/₄"



025

Klemmen mit DEBAKEY-Zahnung
Clamps with Toothing DEBAKEY
Pinzas-clamps con dentado DEBAKEY
Pinze con dentatura DEBAKEY

ATRAUMA



025-493-180 18,0 cm / 7"

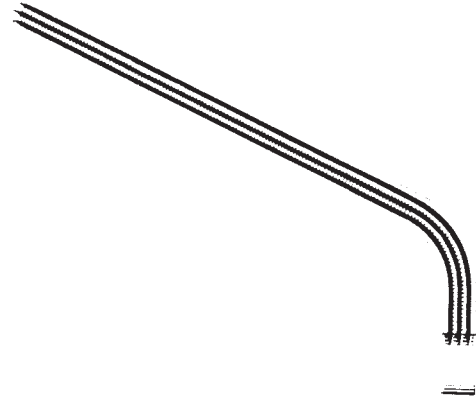

025-493-200 20,0 cm / 8"

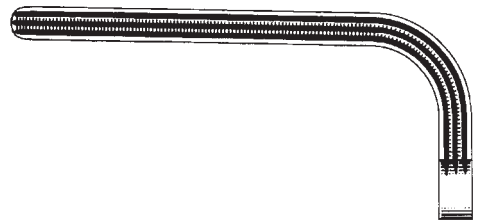

025-493-240 24,0 cm / 9 1/2"

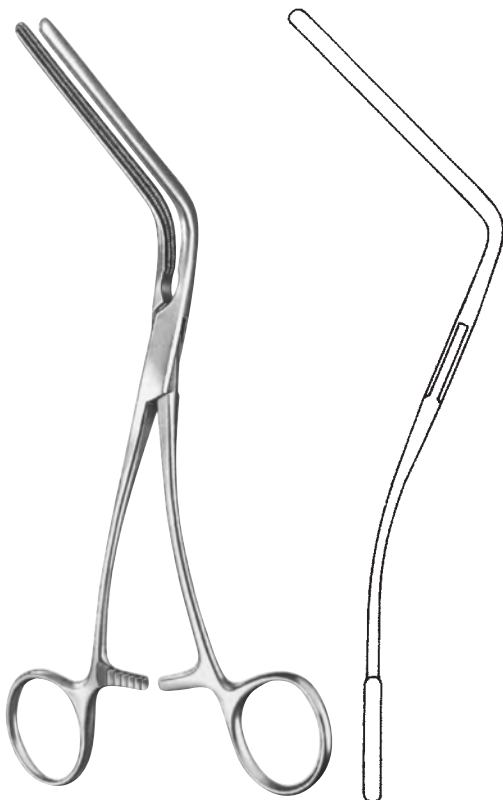

025-493-260 26,0 cm / 10 1/4"

MORRIS-DEBAKEY
025-493-180 - 025-493-260

ATRAUMA

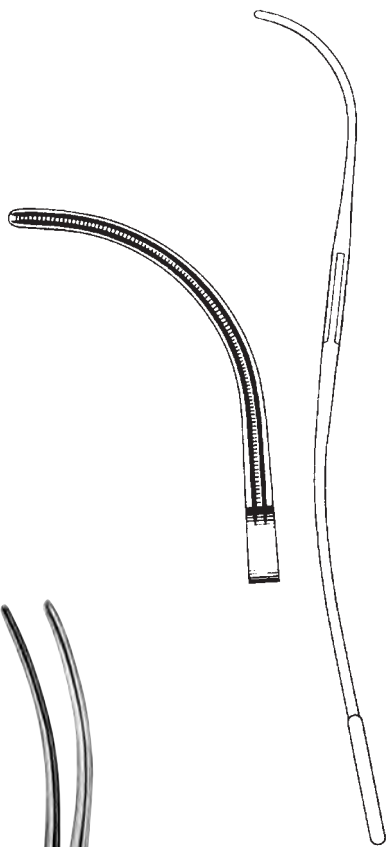

025-495-235 23,5 cm / 9¹/₄"

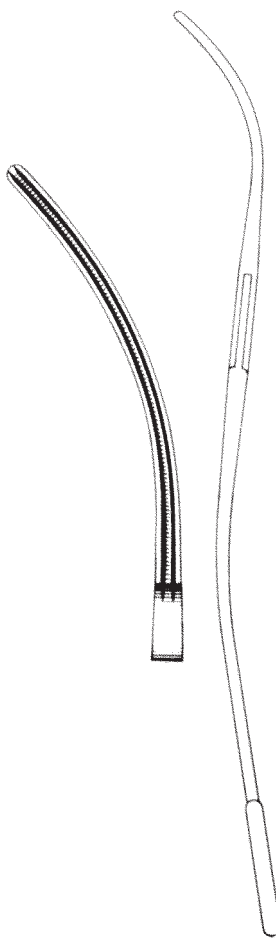

025-495-245 24,5 cm / 9¹/₂"



025-495-255 25,5 cm / 10"



BAHNSON-DEBAKEY

025-495-235 - 025-495-255



025

Klemmen mit DEBAKEY-Zahnung
Clamps with Toothing DEBAKEY
Pinzas-clamps con dentado DEBAKEY
Pinze con dentatura DEBAKEY

ATRAUMA



POTTS

025-500-215 - 025-500-310



025-500-215
21,5 cm / 8¹/₂"



025-500-235
23,5 cm / 9¹/₄"



025-500-270
27,0 cm / 10³/₄"



025-500-310
31,0 cm / 12¹/₄"



POTTS

025-501-210 - 025-501-305



025-501-210
21,0 cm / 8¹/₄"



025-501-230
23,0 cm / 9"

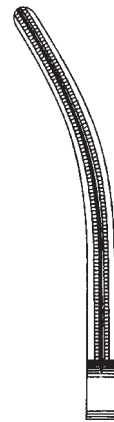

025-501-260
26,0 cm / 10¹/₄"

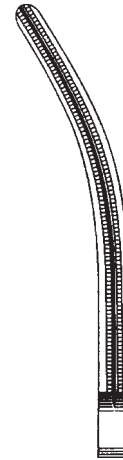

025-501-305
30,5 cm / 12"

ATRAUMA

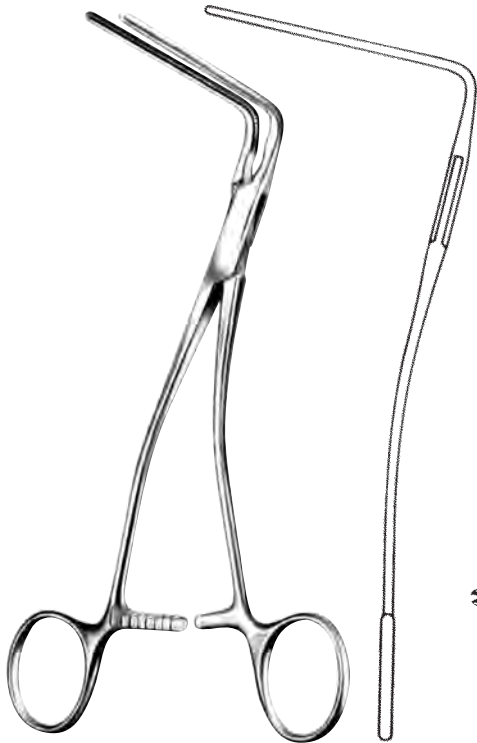

DEBAKEY
 025-511-180 - 025-511-255

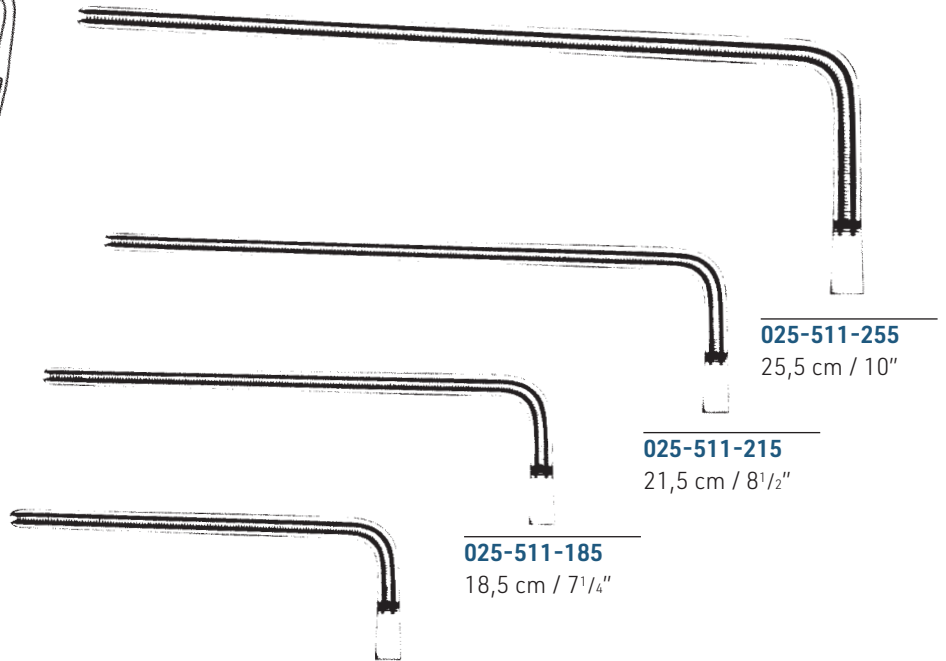

025-511-255
 25,5 cm / 10"

025-511-215
 21,5 cm / 8 1/2"

025-511-185
 18,5 cm / 7 1/4"

025-511-180
 18,0 cm / 7"

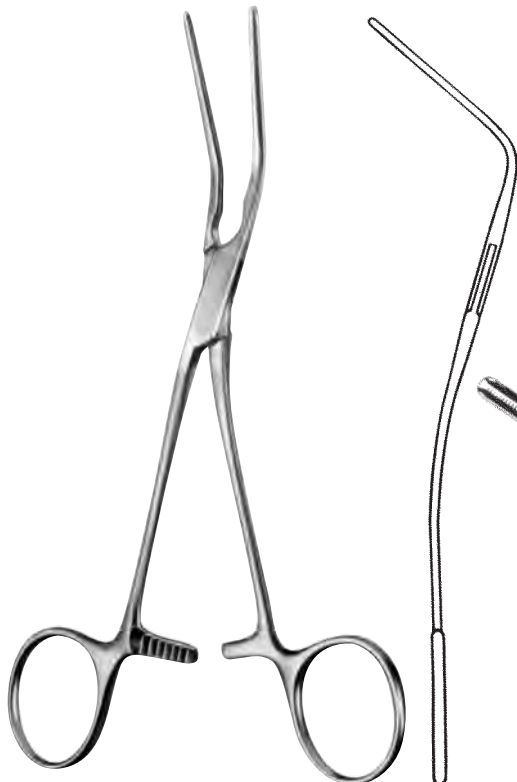

DEBAKEY
 025-513-210 - 025-513-310

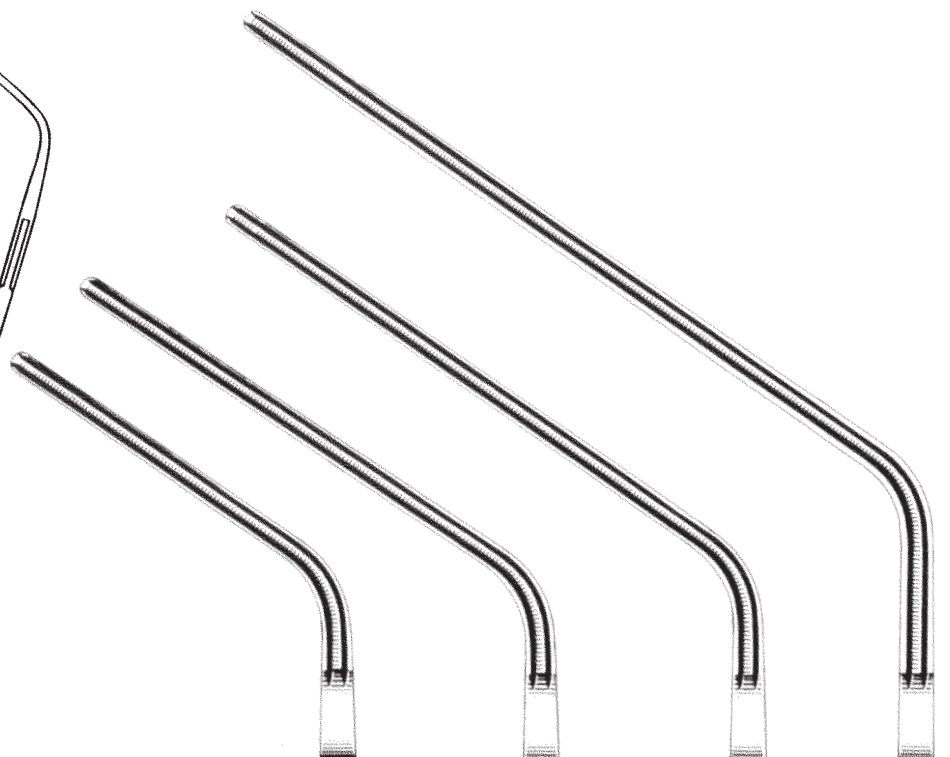

025-513-210
 21,0 cm / 8 1/4"

025-513-220
 22,0 cm / 8 3/4"

025-513-260
 26,0 cm / 10 1/4"

025-513-310
 31,0 cm / 12 1/4"



025

Klemmen mit DEBAKEY-Zahnung
Clamps with Toothing DEBAKEY
Pinzas-clamps con dentado DEBAKEY
Pinze con dentatura DEBAKEY

ATRAUMA



DEBAKEY
025-520-170 17,0 cm / 6³/₄"



DEBAKEY
025-521-165 16,5 cm / 6¹/₂"

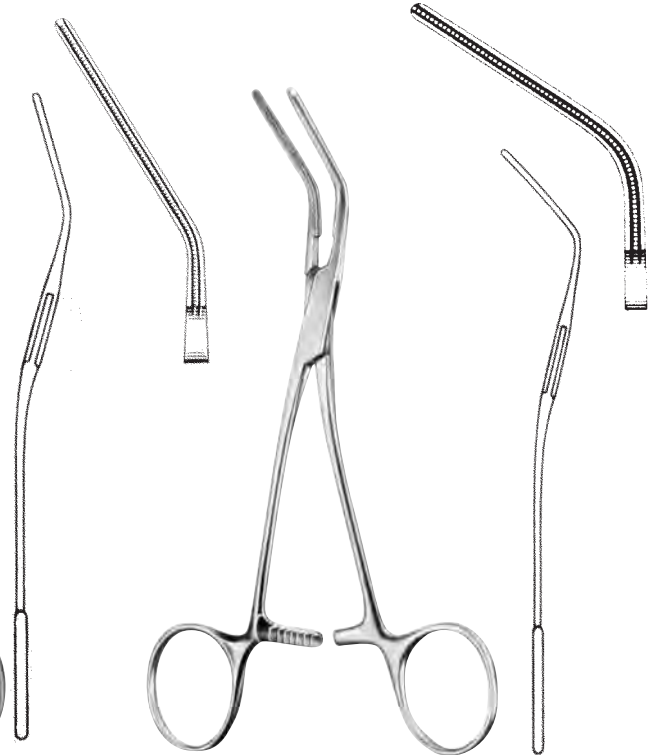

DEBAKEY
025-523-160 16,0 cm / 6¹/₄"



DEBAKEY
025-525-145 14,5 cm / 5³/₄"



DEBAKEY
025-527-165 16,5 cm / 6¹/₂"

ATRAUMA



GLOVER

025-531-170

17,0 cm / 6³/₄"



GLOVER

025-533-175

17,5 cm / 7"



DEBAKEY

025-541-001 - 025-541-002

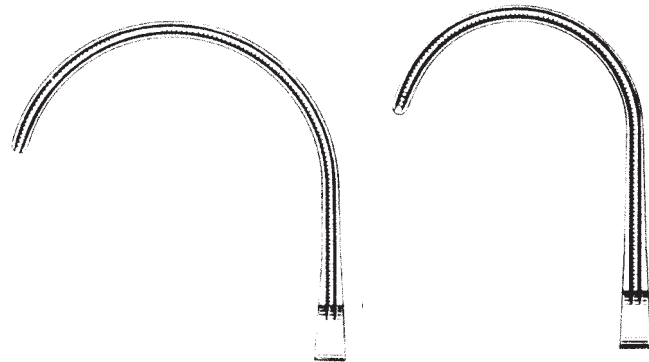

025-541-001

16,5 cm / 6¹/₂"

025-541-002

17,0 cm / 6³/₄"



025

Klemmen mit DEBAKEY-Zahnung
Clamps with Toothing DEBAKEY
Pinzas-clamps con dentado DEBAKEY
Pinze con dentatura DEBAKEY

ATRAUMA



DERRA

025-551-165 - 025-551-180

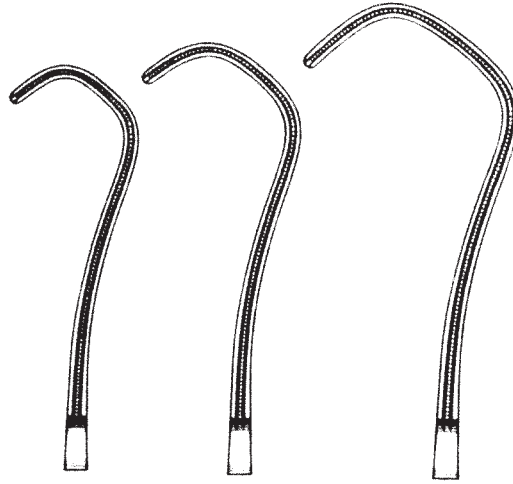

Fig. 1

025-551-165

16,5 cm / 6¹/₂"

Fig. 2

025-551-170

17,0 cm / 6³/₄"

Fig. 3

025-551-180

18,0 cm / 7"



BECK

025-561-170 17,0 cm / 6³/₄"

ATRAUMA



OCHSNER

025-571-235

23,5 cm / 9¹/₄"



DIETRICH

025-573-220

22,0 cm / 8³/₄"



025

Klemmen mit DEBAKEY-Zahnung
Clamps with Toothing DEBAKEY
Pinzas-clamps con dentado DEBAKEY
Pinze con dentatura DEBAKEY

ATRAUMA



GREGORY

025-581-140 - 025-581-180

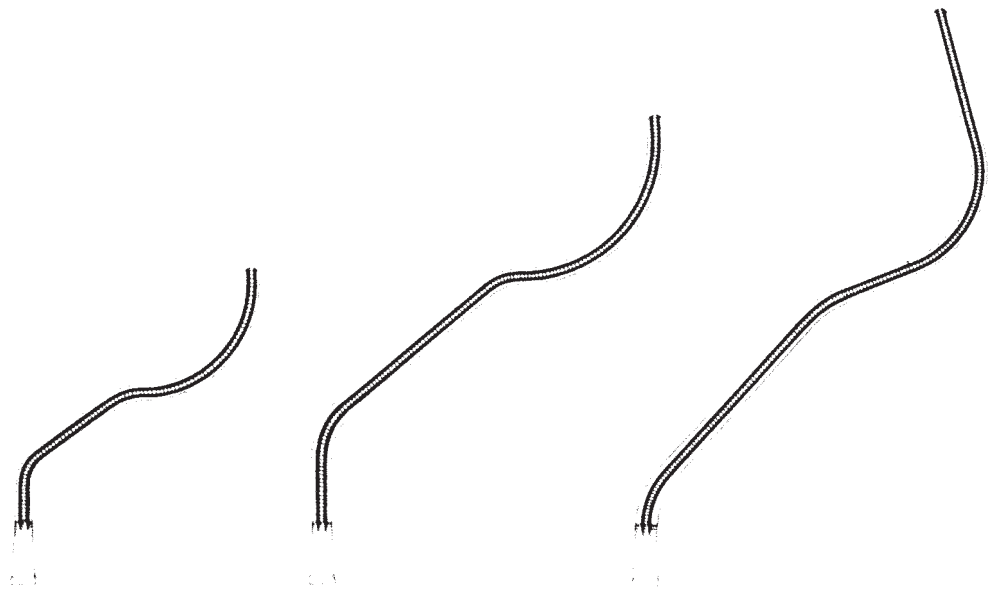

025-581-140
14,0 cm / 5¹/₂"

025-581-160
16,0 cm / 6¹/₄"

025-581-180
18,0 cm / 7"

ATRAUMA



DALE

025-591-180 18,0 cm / 7"



DALE

025-593-175 - 025-593-190

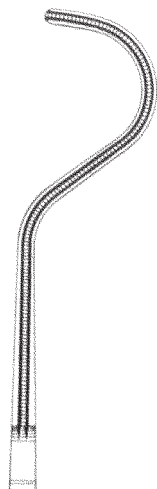

025-593-175
17,5 cm / 6³/₄"

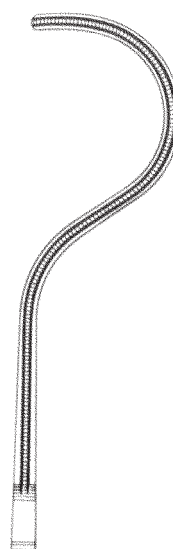

025-593-180
18,0 cm / 7"

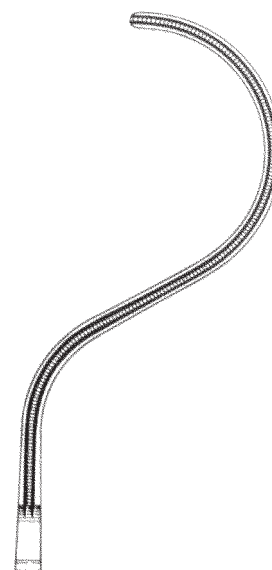

025-593-190
19,0 cm / 7¹/₂"



025

Klemmen mit DEBAKEY-Zahnung
Clamps with Toothing DEBAKEY
Pinzas-clamps con dentado DEBAKEY
Pinze con dentatura DEBAKEY

ATRAUMA

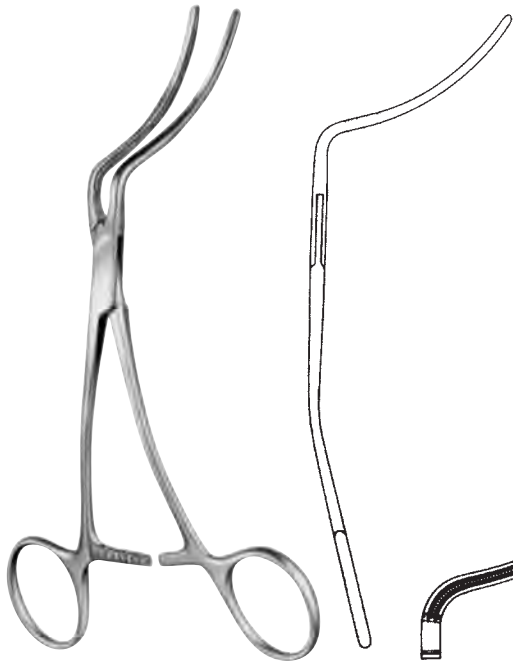

MARTIN

025-601-160

16,0 cm / 6¹/₄"

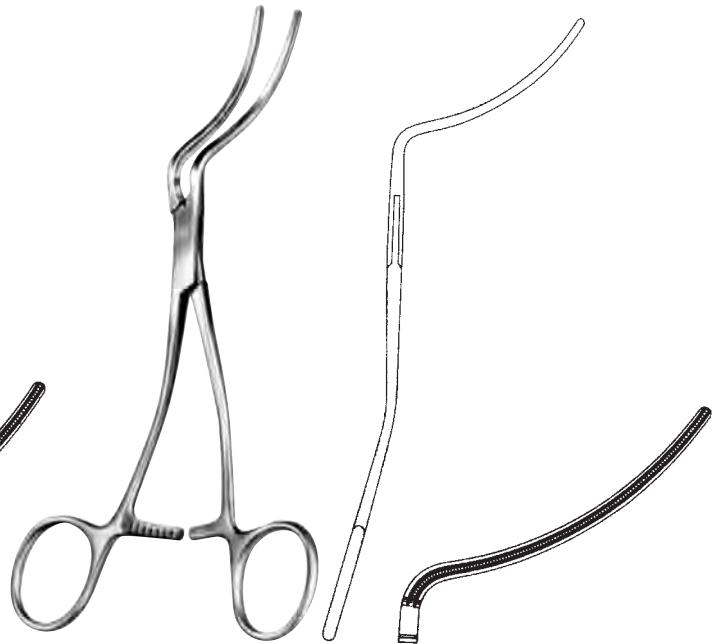

MARTIN

025-601-165

16,5 cm / 6¹/₂"



MARTIN

025-601-180

18,0 cm / 7"

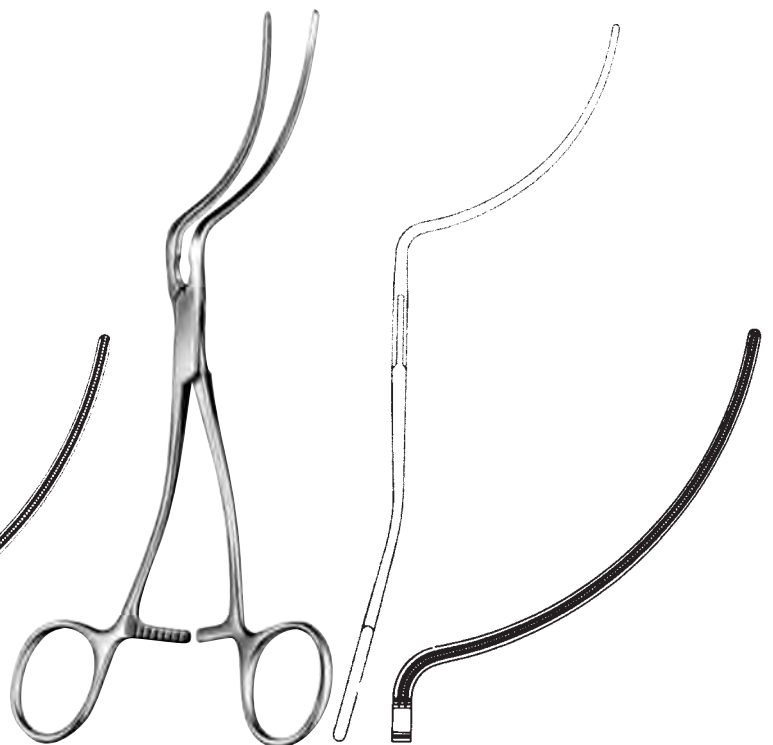

MARTIN

025-601-195

19,5 cm / 7³/₄"

ATRAUMA



HUSFELDT
025-611-175 17,5 cm / 7"



HUSFELDT
025-613-180 18,0 cm / 7"



HUSFELDT
025-615-170 17,0 cm / 6³/₄"



025

Klemmen mit DEBAKEY-Zahnung
Clamps with Toothing DEBAKEY
Pinzas-clamps con dentado DEBAKEY
Pinze con dentatura DEBAKEY

ATRAUMA

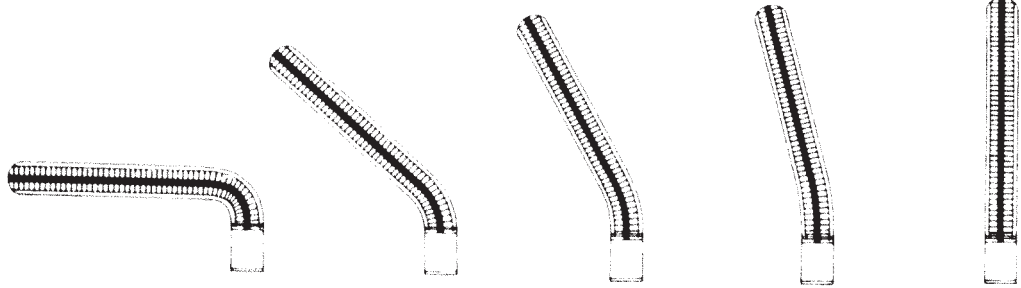

025-621-090
15,0 cm / 5 1/2"
90°

025-621-045
15,0 cm / 5 1/2"
45°

025-621-030
15,0 cm / 5 1/2"
30°

025-621-015
15,0 cm / 5 1/2"
15°

025-622-150
15,0 cm / 5 1/2"

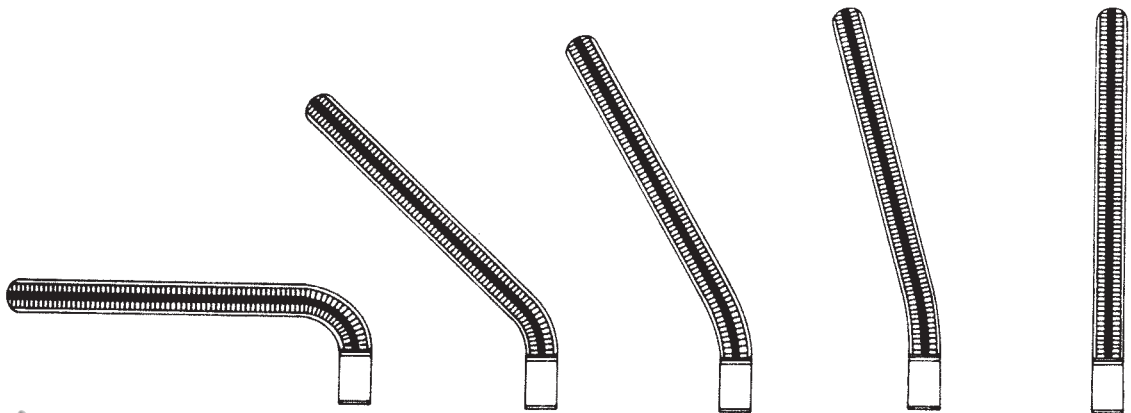

025-623-090
17,0 cm / 6 1/2"
90°

025-623-045
17,0 cm / 6 1/2"
45°

025-623-030
17,0 cm / 6 1/2"
30°

025-623-015
17,0 cm / 6 1/2"
15°

025-624-170
17,0 cm / 6 1/2"



DARDIK

025-621-090 - 025-622-150 15,0 cm / 5 1/2"
025-623-090 - 025-624-170 17,0 cm / 6 1/2"

ATRAUMA

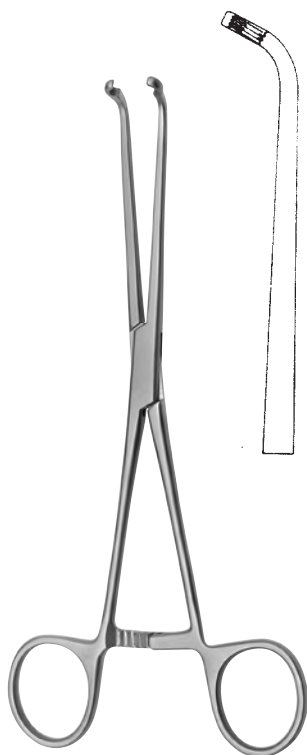

JAVID

025-631-175 17,5 cm / 7"

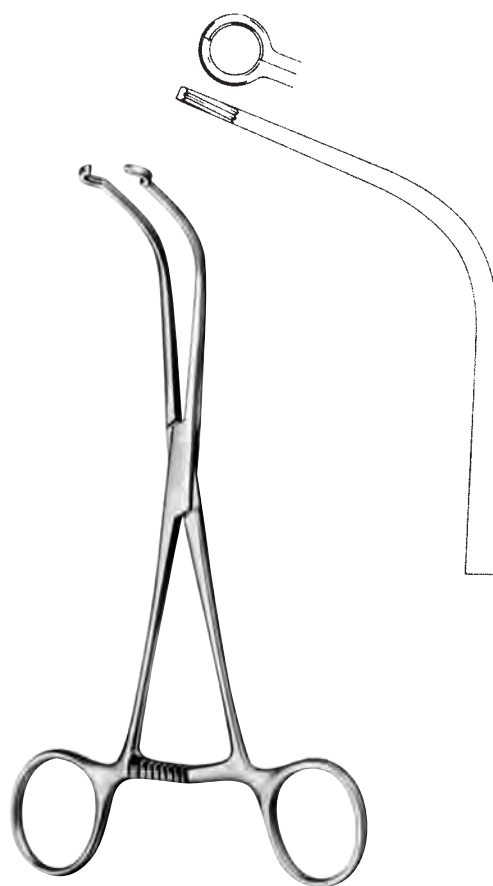

JAVID

025-633-190 19,0 cm / 7 1/2"



025

Klemmen mit DEBAKEY-Zahnung
Clamps with Toothing DEBAKEY
Pinzas-clamps con dentado DEBAKEY
Pinze con dentatura DEBAKEY

ATRAUMA



SUBRAMANIAN-MINIATURE

025-651-155 15,5 cm / 6"

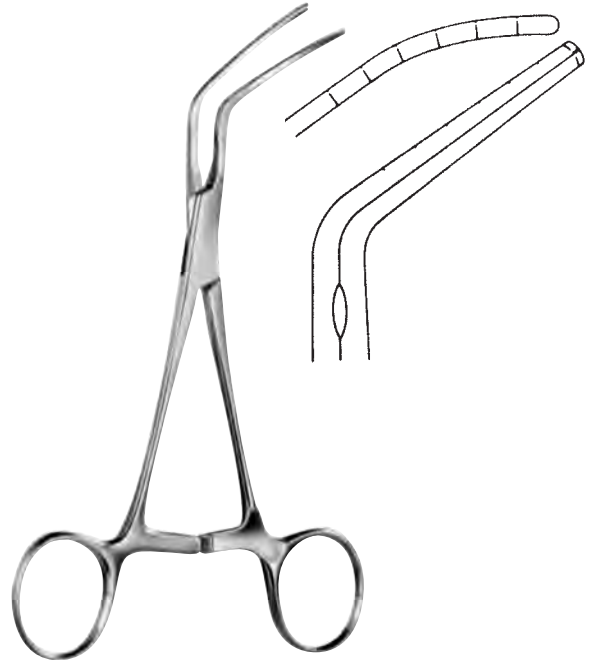

SUBRAMANIAN

025-653-160 16,0 cm / 6¹/₄"

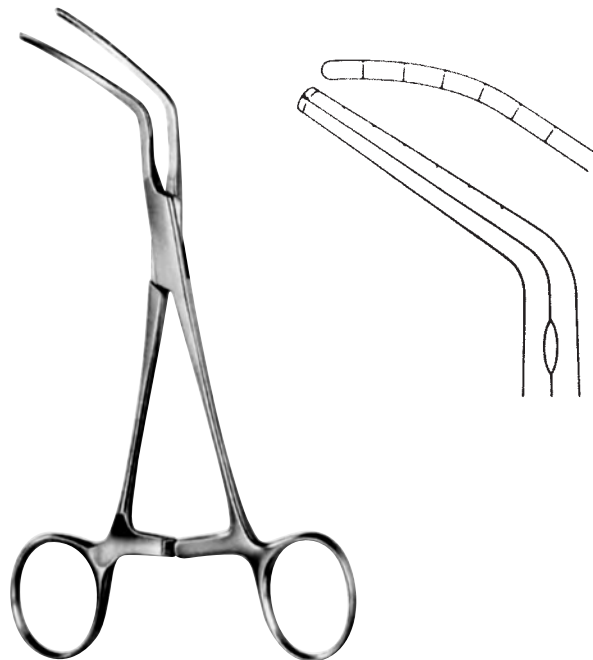

SUBRAMANIAN

025-655-160 16,0 cm / 6¹/₄"

ATRAUMA

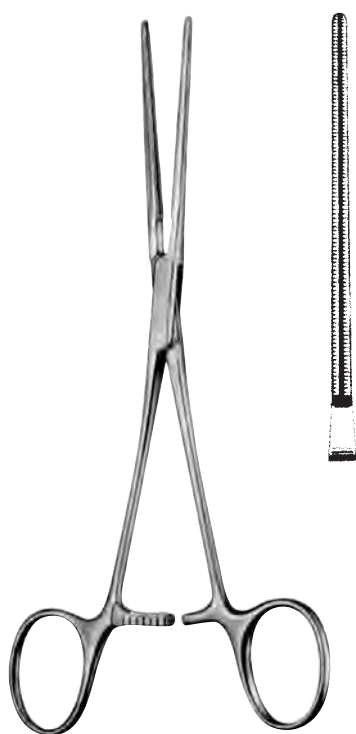

COOLEY

025-700-170 17,0 cm / 6³/₄"



COOLEY

025-701-220 22,0 cm / 8³/₄"

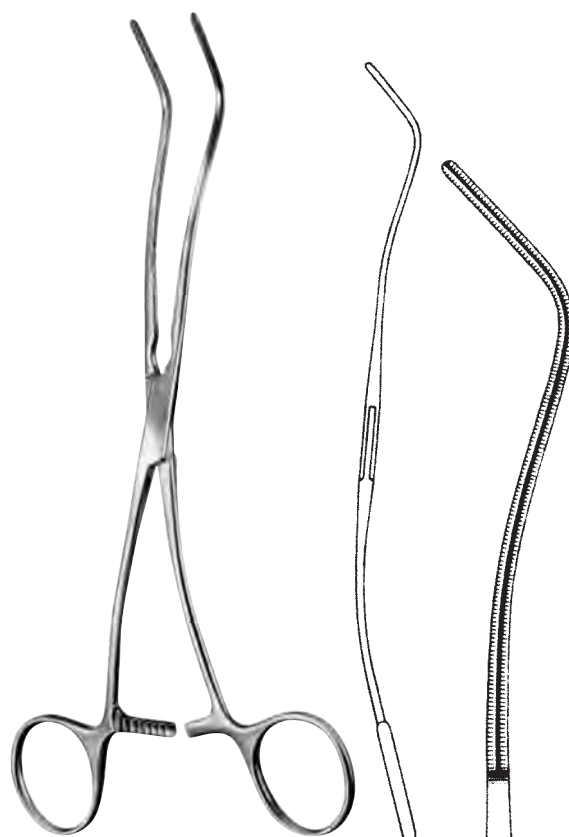

COOLEY

025-703-200 20,0 cm / 8"



025

Klemmen mit COOLEY-Zahnung
Clamps with Toothing COOLEY
Pinzas con dentado COOLEY
Pinze con dentatura COOLEY

ATRAUMA

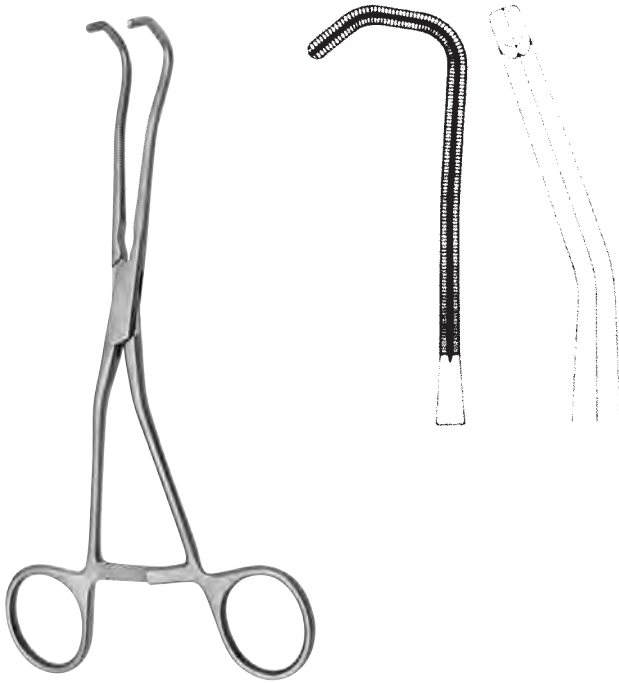

COOLEY

025-711-170

17,0 cm / 6³/₄"



COOLEY

025-713-160

16,0 cm / 6¹/₄"



COOLEY

025-721-140

14,0 cm / 5¹/₂"



COOLEY

025-721-160

16,0 cm / 6¹/₄"

ATRAUMA



COOLEY

025-721-170

17,0 cm / 6³/₄"

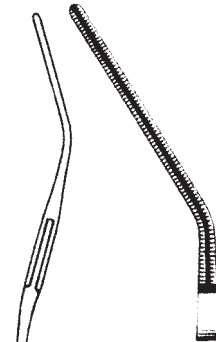

COOLEY

025-723-170

17,0 cm / 6³/₄"



COOLEY

025-725-170

17,0 cm / 6³/₄"



025

Klemmen mit COOLEY-Zahnung
Clamps with Toothing COOLEY
Pinzas con dentado COOLEY
Pinze con dentatura COOLEY

ATRAUMA



COOLEY

025-727-175

17,5 cm / 7"



025-729-170

17,0 cm / 6³/₄"

025-729-165

16,5 cm / 6¹/₂"

COOLEY

025-729-165 - 025-729-170

ATRAUMA

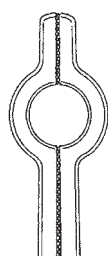

025-741-001
16,0 cm / 6¹/₄"
24 Charr.

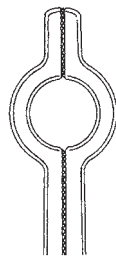

025-741-002
16,0 cm / 6¹/₄"
26 Charr.

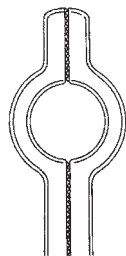

025-741-003
20,0 cm / 8"
28 Charr.

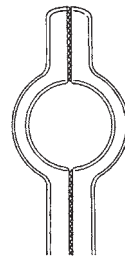

025-741-004
20,0 cm / 8"
30 Charr.

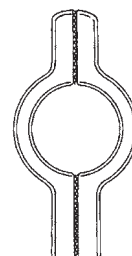

025-741-005
20,0 cm / 8"
32 Charr.

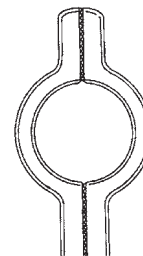

025-741-007
20,0 cm / 8"
36 Charr.

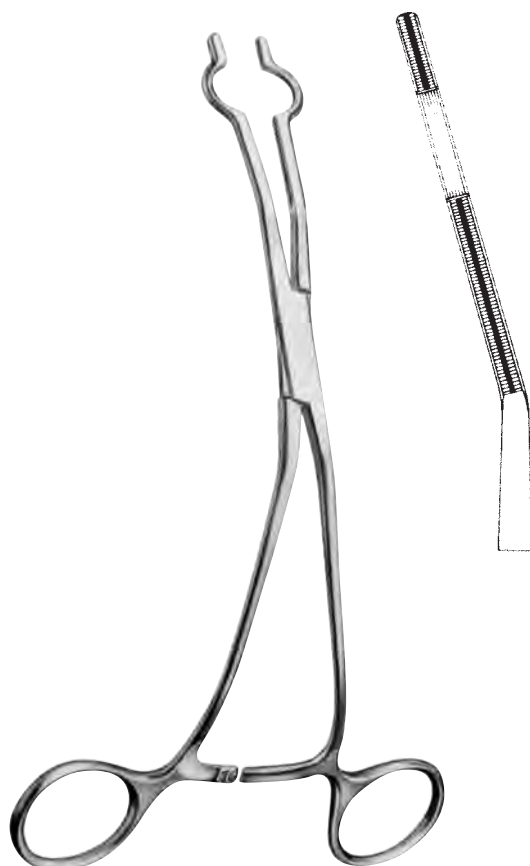

COOLEY

025-741-001 - 025-741-007



025

Klemmen mit COOLEY-Zahnung
Clamps with Toothing COOLEY
Pinzas con dentado COOLEY
Pinze con dentatura COOLEY

ATRAUMA



COOLEY-DERRA

025-751-165 - 025-751-175

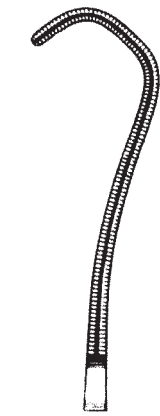

025-751-165

16,5 cm / 6¹/₂"

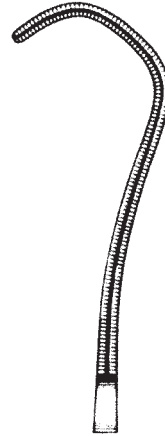

025-751-170

17,0 cm / 6³/₄"

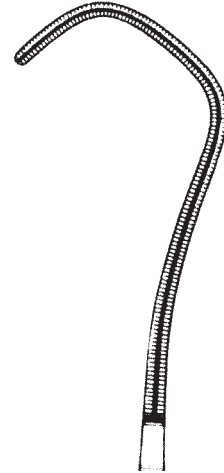

025-751-175

17,5 cm / 7"



COOLEY-BECK

025-761-170

17,0 cm / 6³/₄"

ATRAUMA

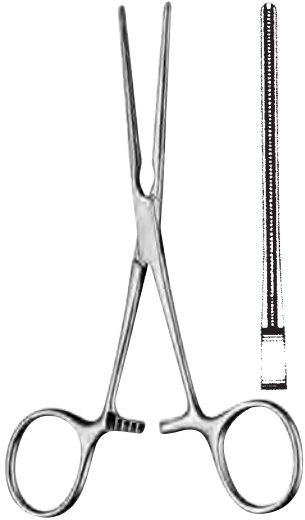

DEBAKEY
025-800-130 13,0 cm / 5"

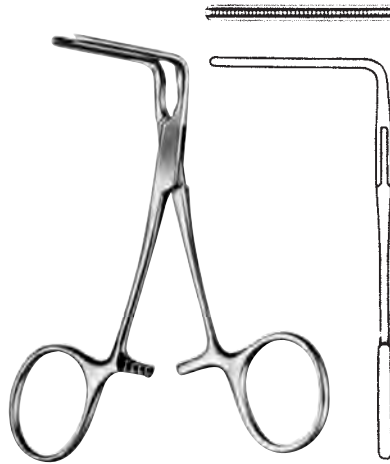

DEBAKEY
025-801-100 10,0 cm / 4"

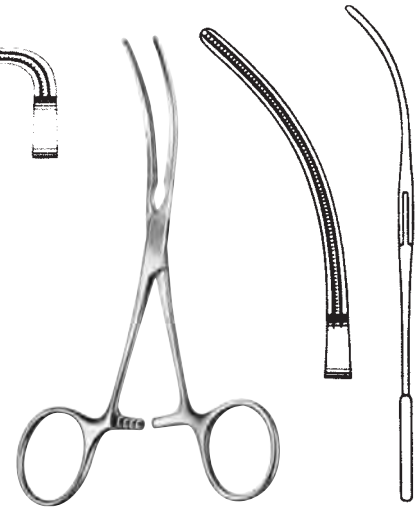

DEBAKEY
025-803-125 12,5 cm / 5"



DEBAKEY
025-805-125 12,5 cm / 5"

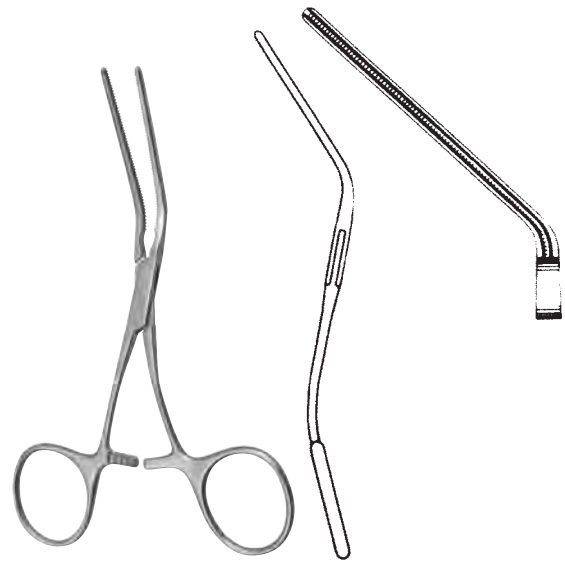

DEBAKEY
025-807-125 12,5 cm / 5"



025

Klemmen mit COOLEY-Zahnung
Clamps with Toothing COOLEY
Pinzas con dentado COOLEY
Pinze con dentatura COOLEY

ATRAUMA

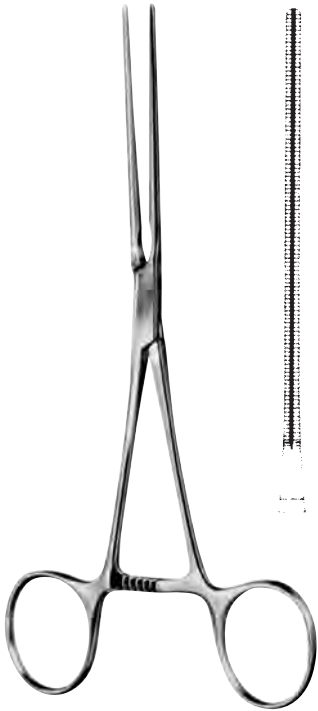

COOLEY

025-820-165

16,5 cm / 6 1/2"



COOLEY

025-821-160

16,0 cm / 6 1/4"

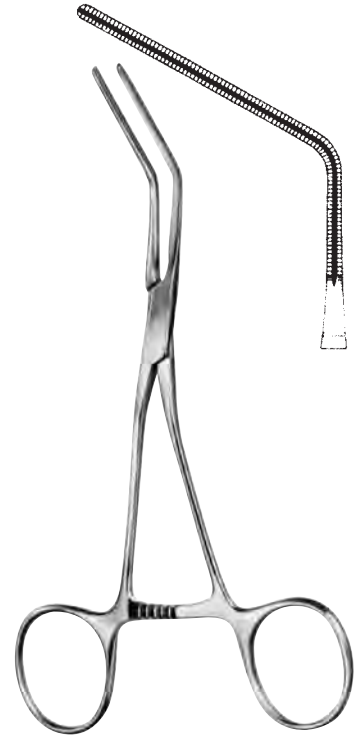

COOLEY

025-823-155

15,5 cm / 6"



COOLEY

025-825-155

15,5 cm / 6"

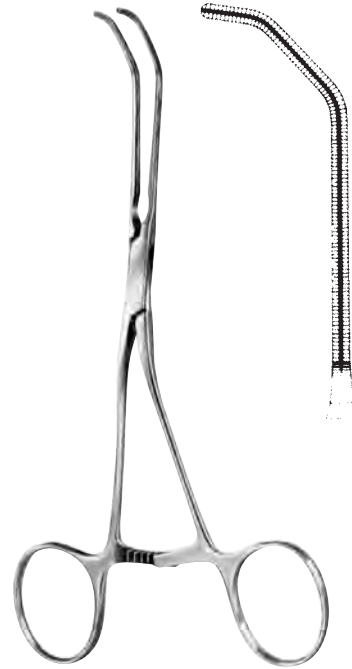

COOLEY

025-827-160

16,0 cm / 6 1/4"

ATRAUMA

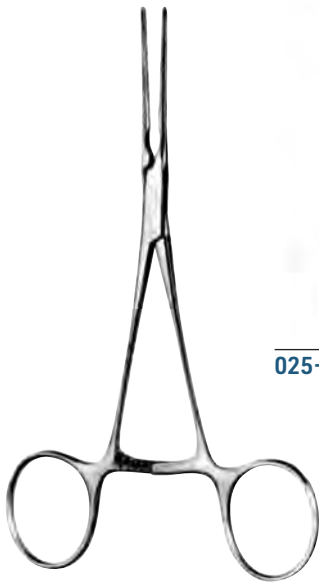

025-830-140



025-831-140

COOLEY

025-830-140 - 025-831-140 14,0 cm / 5 1/2"

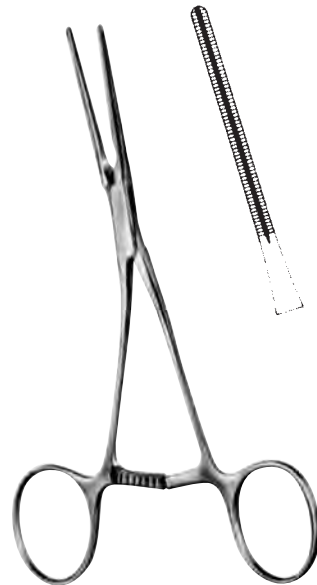

COOLEY

025-833-140 14,0 cm / 5 1/2"



COOLEY

025-835-140 14,0 cm / 5 1/2"



COOLEY

025-837-140 14,0 cm / 5 1/2"



025

Klemmen mit COOLEY-Zahnung
Clamps with Toothing COOLEY
Pinzas con dentado COOLEY
Pinze con dentatura COOLEY

ATRAUMA



Fig.1
025-840-001
13,5 cm / 5 1/4"

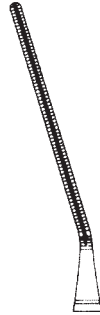

Fig.2
025-840-002
13,5 cm / 5 1/4"

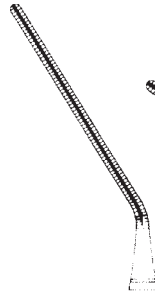

Fig.3
025-840-003
14,0 cm / 5 1/2"

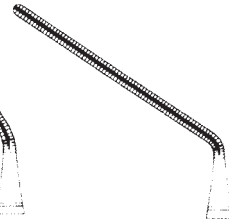

Fig.4
025-840-004
13,5 cm / 5 1/4"



Fig.5
025-840-005
13,5 cm / 5 1/4"

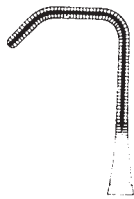

Fig.6
025-840-006
12,5 cm / 5"

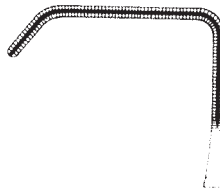

Fig.7
025-840-007
13,0 cm / 5"

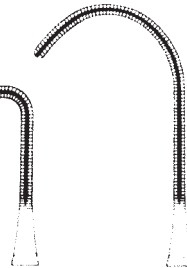

Fig.8
025-840-008
13,5 cm / 5 1/4"



Fig.9
025-840-009
13,0 cm / 5"



COOLEY

025-840-001 - 025-840-009

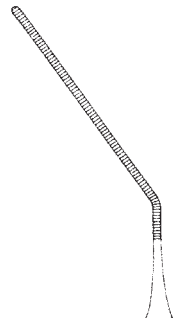

Fig.1
025-851-001
 12,5 cm / 5"

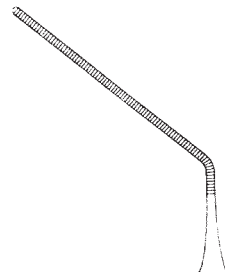

Fig.2
025-851-002
 11,5 cm / 4 1/2"



Fig.3
025-851-003
 11,0 cm / 4 1/4"

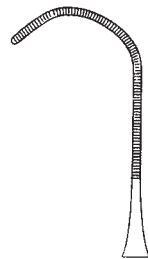

Fig.1
025-853-001
 11,5 cm / 4 1/2"



Fig.2
025-853-002
 12,0 cm / 4 3/4"

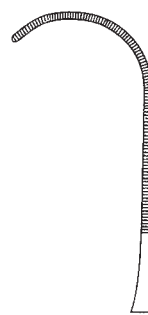

Fig.3
025-853-003
 12,0 cm / 4 3/4"

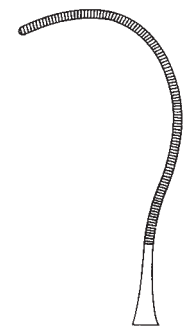

Fig.4
025-853-004
 12,0 cm / 4 3/4"



CASTAÑEDA
025-851-001 - 025-853-004



025

Dilatatoren
Dilators
Dilatadores
Dilatatori

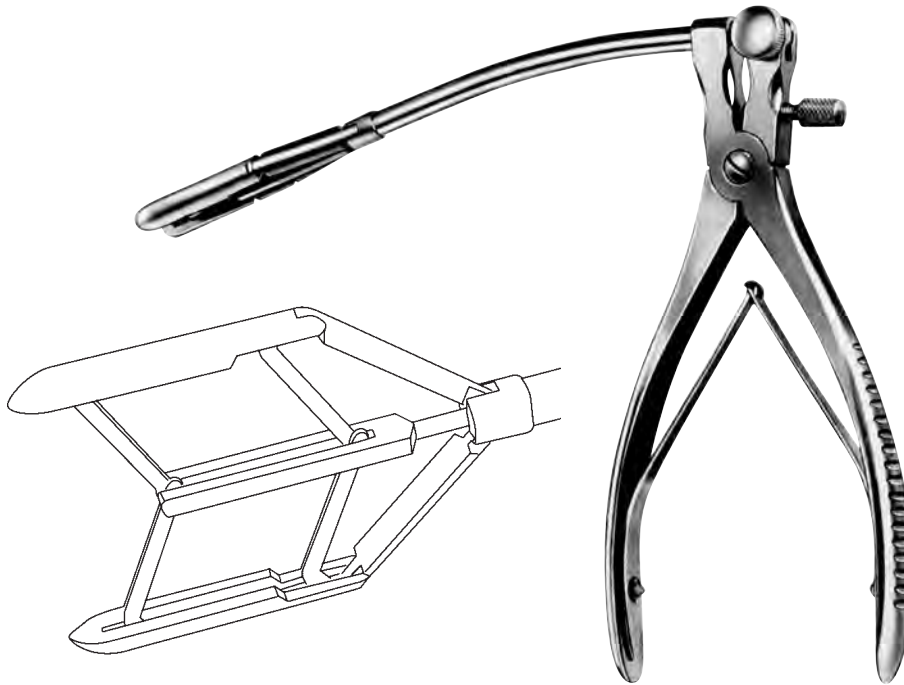

Spreizweite 8-42 mm, mit Feststellschraube
spreading 8-42 mm, with foxatopm screw
abertura 8-42 mm, con tornillo de ajuste
apertura totale 8-42 mm, con vite di fissazione

TUBBS

025-901-000

für Mitralstenosen
for mitral stenosis
para estenosis mitral
per stenosi mitrali

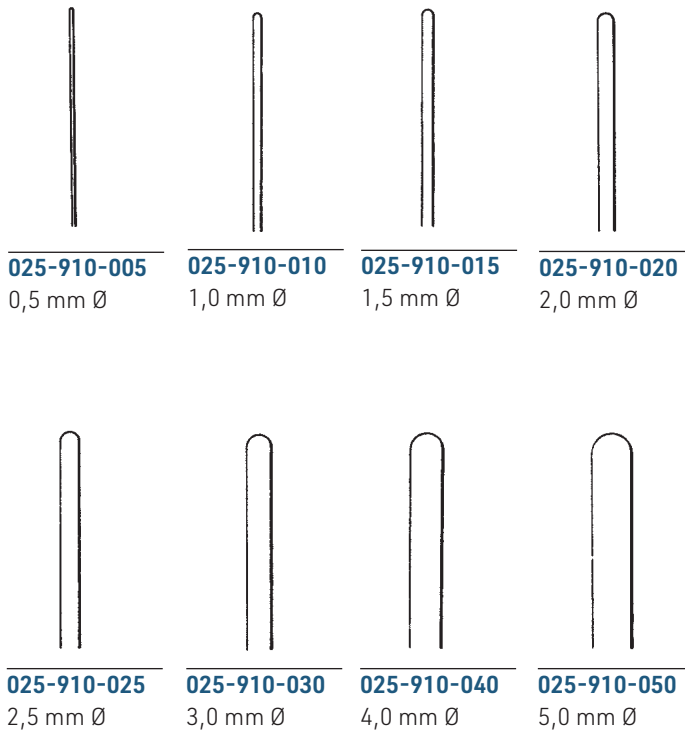

COOLEY

025-910-005 - 025-910-050 13,0 cm / 5"

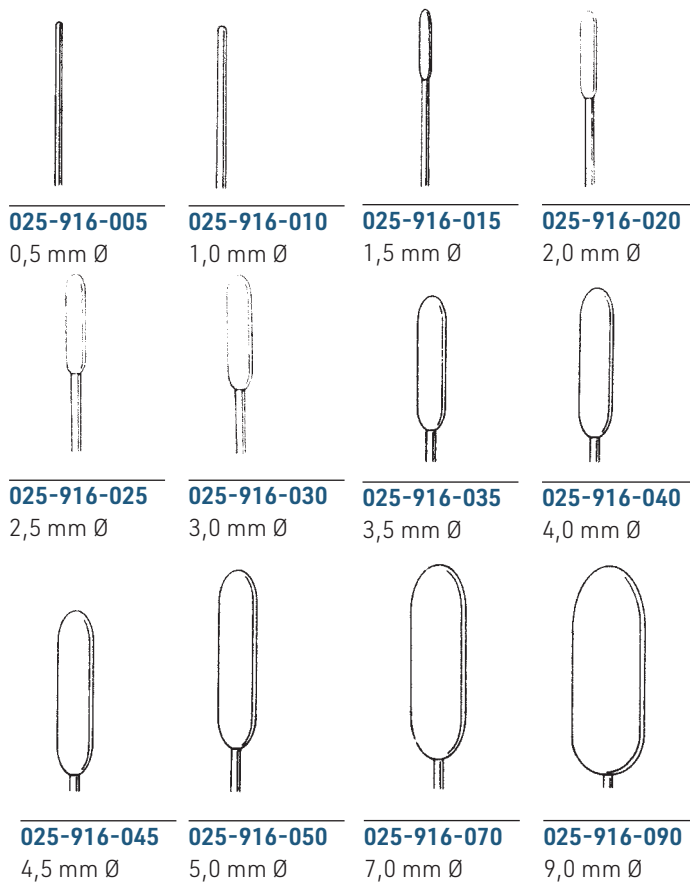

DEBAKEY

025-916-005 - 025-916-090 19,0 cm / 7 1/2"

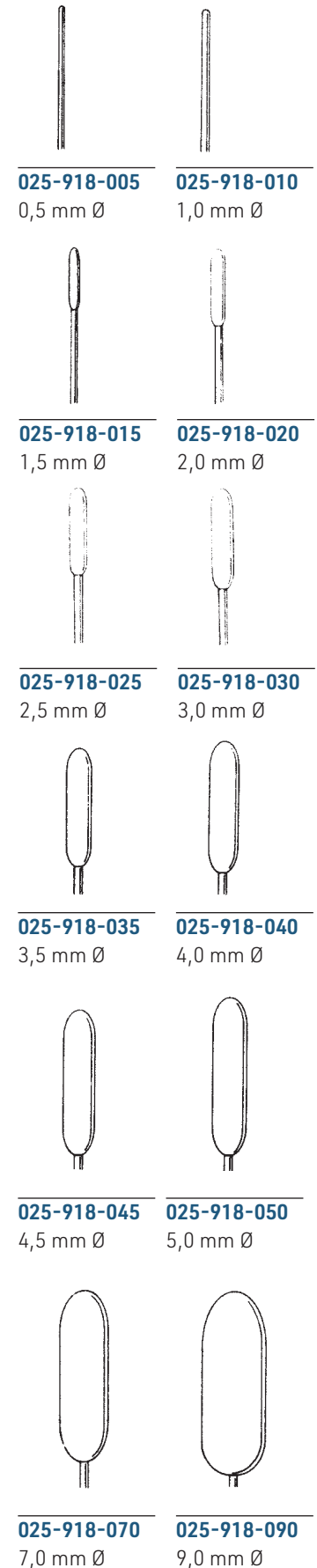

DEBAKEY

025-918-005 - 025-918-090 35,0 cm / 13 3/4"



025

Intimaspatel, Gefäßdissektoren
Intima Spatulas, Vascular Dissectors
Espátulas para la íntima, Disecadores vasculares
Spatole per intima, Dissettori vascolari

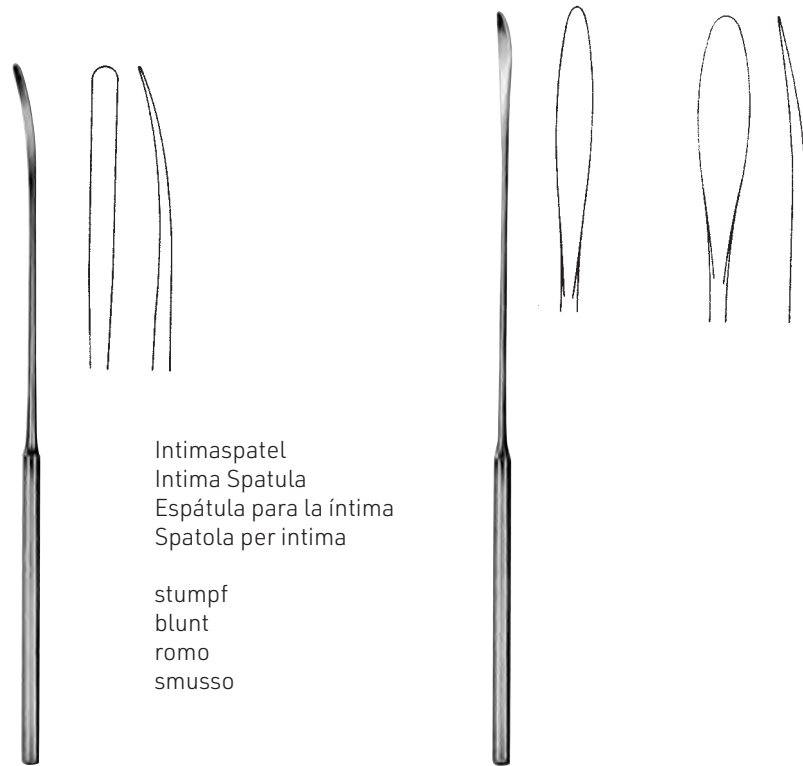

Intimaspatel
Intima Spatula
Espátula para la íntima
Spatola per intima

stumpf
blunt
romo
smusso

025-941-185 18,5 cm / 7¹/₄"
025-941-215 21,5 cm / 8¹/₂"

025-943-140 14,0 cm / 5¹/₂"
025-943-235 23,5 cm / 9¹/₄"

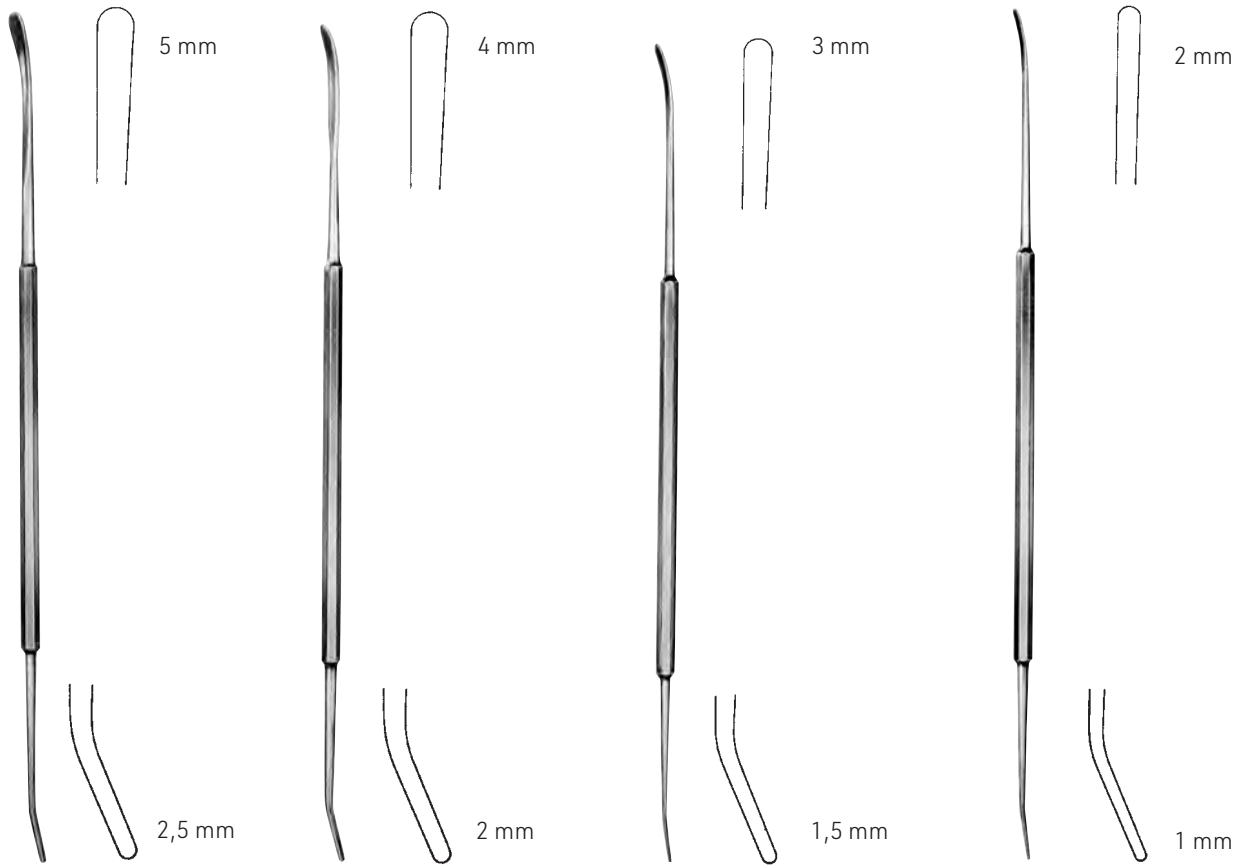

ROBB

025-945-001 24,0 cm / 9 1/2"
 Fig. 1

ROBB

025-945-002 24,0 cm / 9 1/2"
 Fig. 2

ROBB

025-945-003 24,0 cm / 9 1/2"
 Fig. 3

ROBB

025-945-004 24,0 cm / 9 1/2"
 Fig. 4

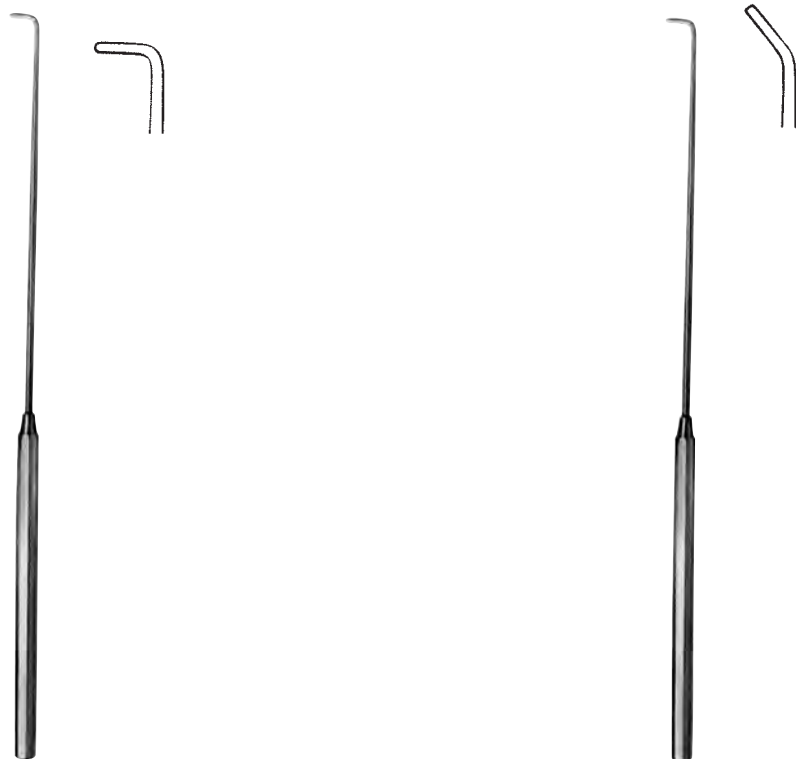

CRILE

025-947-200 20,0 cm / 8"

CRILE

025-949-205 20,5 cm / 10 1/4"



025

Nervhäkchen, Tourniquets
Nerve Hooklets, Tourniquets
Ganchitos para nervios, Tourniquetes
Uncini per nerve, Tornichetti



025-960-015 - 025-960-030 26,0 cm / 10"



025-960-015
1,5 mm



025-960-020
2,0 mm



025-960-025
2,5 mm



025-960-030
3,0 mm

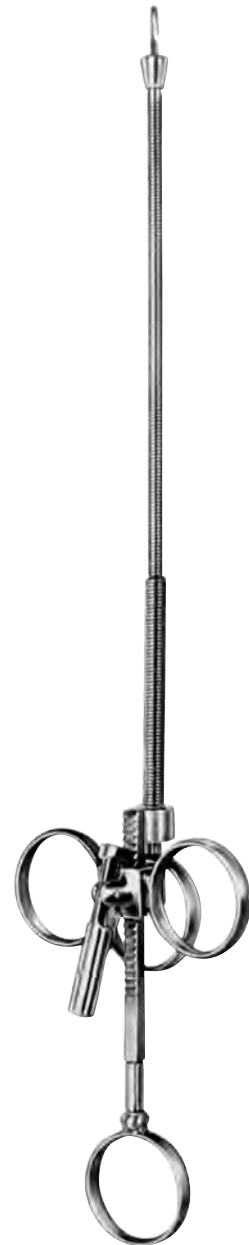

RUMEL-BELMONT

025-970-270 27,0 cm / 10³/₄" 3,2 mm Ø
025-970-330 33,0 cm / 13" 6,4 mm Ø



026

Neurochirurgie,
Laminektomie
Neurosurgery,
Laminectomy
Neurocirugía,
Laminectomía
Neurochirurgia,
Laminectomia

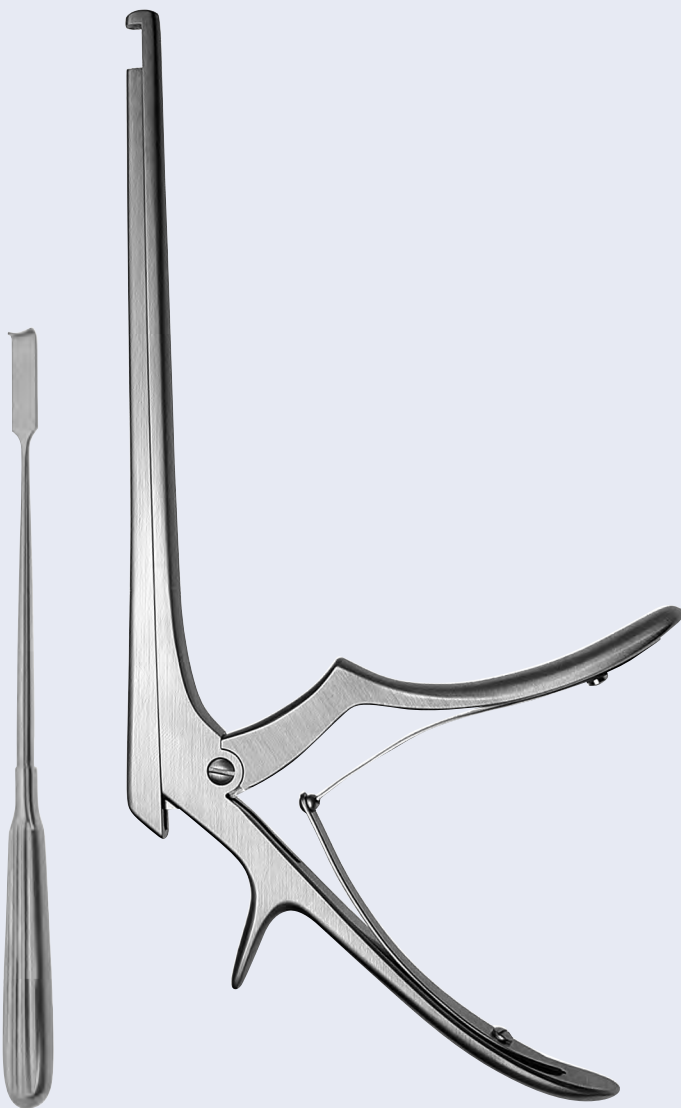



026

Instrumente zur Schädelöffnung
 Instruments for cranial Opening
 Instrumentos para apertura craneana
 Strumenti per apertura del cranio

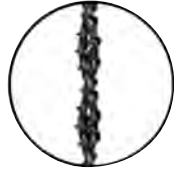
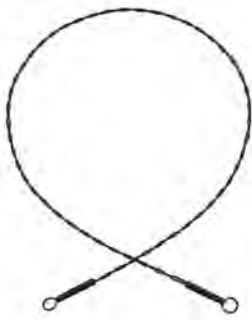

2-teilig
 2 wires twisted
 2 vueltas de hilo
 2-girate

OLIVECRONA

- 026-010-300** 30,0 cm / 12"
- 026-010-400** 40,0 cm / 16"
- 026-010-500** 50,0 cm / 20"
- 026-010-600** 60,0 cm / 24"
- 026-010-700** 70,0 cm / 28"

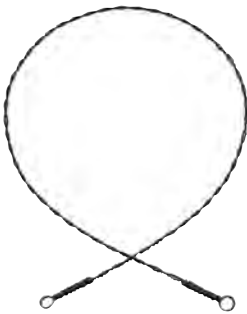

fein, 6-teilig
 fine, 6 wires twisted
 fina, 6 vueltas de hilo
 fino, 6-girate

GIGLIW

- 026-014-300** 30,0 cm / 12"
- 026-014-400** 40,0 cm / 16"
- 026-014-500** 50,0 cm / 20"



GIGLI

- 026-015-007** 7,0 cm / 2 1/4"

Einführungsinstrument für Drahtsägen
 Conductor for wire saws
 Conductor para sierras de hilo
 Introduttore per fili per sega



DE MARTEL

- 026-020-330** 33,0 cm / 13"

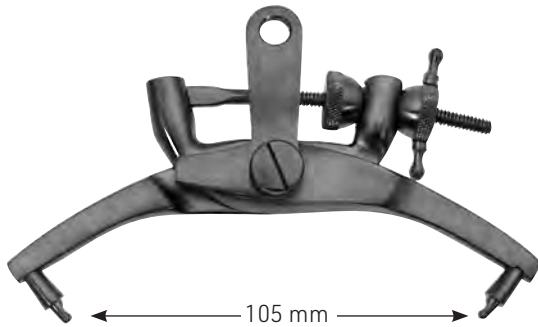

CRUTCHFIELD
026-030-105

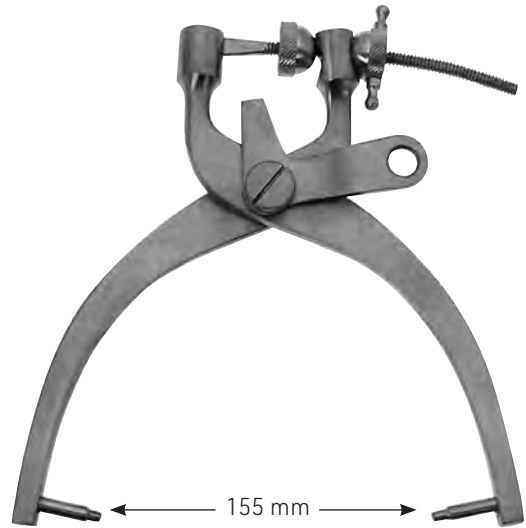

CRUTCHFIELD
026-030-155



CRUTCHFIELD
026-032-035 Ø 3,5 mm



CRUTCHFIELD
026-032-050 Ø 5,0 mm

Vorbohrer für CRUTCHFIELD-Schädelhalter
 Drill point for CRUTCHFIELD cervical traction tongs
 Perforador inicial para pinzas de tracción craneal CRUTCHFIELD
 Alesatore per pinze per trazione craniale di CRUTCHFIELD



026-035-001
 Ersatzdorn
 Spare pin
 Espina de repuesto
 Punta di ricambio

026-034-175

Schädelhalter für Extension der Halswirbel,
 großes Modell, Dorne verstellbar, deshalb
 Vorbohren nicht erforderlich

Cervical traction tongs, for extension of the
 neck vertebrae, large size, pins adjustable
 hence no initial drilling

Pinza de tracción craneal para la extensión
 de las vertebrae de cuello, tamaño grande,
 puntas ajustables suprimiendo perforaciones
 iniciales

Pinza per trazione craniale e l'estensione delle
 vertebre del collo, modello grande, punte
 regolabili al fine di evitare la perforazione iniziale



026

Schädelstanzen
Cranial Rongeur Forceps
Pinzas sacabocados craneales
Pinze per ossa del cranio



DAHLGREN

026-040-200 20,0 cm / 8"



026-041-001

Schädelstanze
Cranial rongeur
Pinza saca-bocado craneal
Pinza per cranio



DE VILBISS

026-044-210 21,0 cm / 8 1/4"



Fig. 4

026-045-004

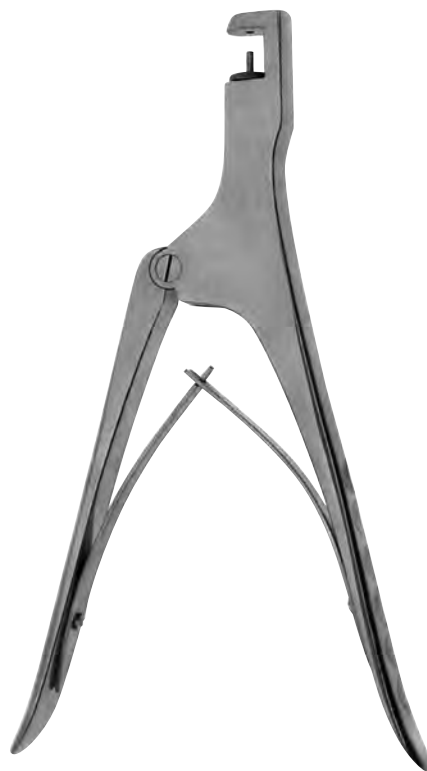

Fig. 5

026-045-005

Schädelstanze
Cranial rongeur
Pinza saca-bocado craneal
Pinza per cranio

Schädelstanzzange
Cranial punch rongeur
Pinza saca-bocados craneal
Pinza per cranio



CONE

026-048-225 22,5 cm / 9"



026

Klammerinstrumentarium, Galeahaken
Clip Instruments, Galea Hooks
Instrumental para grapar, Gancho para galea
Strumenti per mettere i punti, Ganci galea



RANEY

026-058-001

Kopfhautklammern
Scalp hemostasis clips
Grapa hemostática para cuero cabelludo
Agrafes emostatici per cuoio capelluto



RANEY

026-062-160 16,0 cm / 6 1/4"

Anlege- und Abnehmezange
für Kopfhautklammern
Applying an removing forceps
for scalp hemostasis clips
Pinza para aplicar y quitar clips
hemostáticas de cuero cabelludo
Pinza per applicare e togliere le agrafes
emostatiche al cuoio capelluto



LEYLA

026-100-001

Selbsthaltender Spatel mit 1 Spannarm, komplett, bestehend aus:

- 1 Spannarm, flexibel (**026-100-010**)
- 1 Fixiervorrichtung für 1 Spannarm (**026-100-020**)
- 1 Spatelhalter für flache Spatel (**026-100-031**)

Self-retaining retractor with 1 arm, complete, consisting of:

- 1 Flexible arm (**026-100-010**)
- 1 Fixation base for 1 arm (**026-100-020**)
- 1 Support for flat spatulas (**026-100-031**)

Separador automático con 1 brazo, completo, compuesto de:

- 1 Brazo, flexible (**026-100-010**)
- 1 Fijador para 1 brazo (**026-100-020**)
- 1 Porta-espátula para espátulas planas (**026-100-031**)

Autofissatore per retrattore con 1 braccio, completo, composto da:

- 1 Braccio flessibile (**026-100-010**)
- 1 Base di fissaggio per 1 braccio (**026-100-020**)
- 1 Supporto per spatole cervicali piatte (**026-100-031**)

LEYLA

026-100-002

Selbsthaltender Spatel mit 2 Spannarm, komplett, bestehend aus:

- 2 Spannarm, flexibel (**026-100-020**)
- 1 Fixiervorrichtung für 2 Spannarme (**026-100-021**)
- 2 Spatelhalter für flache Spatel (**026-100-031**)

Self-retaining retractor with 2 arm, complete, consisting of:

- 2 Flexible arms (**026-100-010**)
- 1 Fixation base for 2 arms (**026-100-021**)
- 2 Supports for flat spatulas (**026-100-031**)

Separador automático con 2 brazos, completo, compuesto de:

- 2 Brazos, flexible (**026-100-010**)
- 1 Fijador para 2 brazos (**026-100-021**)
- 2 Porta-espátula para espátulas planas (**026-100-031**)

Autofissatore per retrattore con 2 bracci, completo, composto da:

- 2 Bracci flessibili (**026-100-010**)
- 1 Base di fissaggio per 2 bracci (**026-100-021**)
- 2 Supporti per spatole cervicali piatte (**026-100-031**)



026

Zubehör zu LEYLA-Retraktoren
Accessories for LEYLA Self-Retaining Retractors
Accesorios para separadores automáticos de LEYLA
Accessori per autofissatori di retrattori di LEYLA



LEYLE

026-100-010

Spannarm
Flexible arm
Brazo flexible
Braccio flessibile



LEYLE

026-100-020

Fixiervorrichtung für 1 Spannarm
Fixation base for 1 arm
Fijador para 1 brazo
Base di fissaggio per 1 braccio



LEYLE

026-100-021

Fixiervorrichtung für 2 Spannarme
Fixation base for 2 arms
Fijador para 2 brazos
Base di fissaggio per 2 bracci



LEYLE

026-100-022

Fixiervorrichtung für 1 Spannarm
Fixation base for 1 arm
Fijador para 1 brazo
Base di fissaggio per 1 braccio



LEYLE

026-100-030

Spatelhalter
Support
Porta-espátula
Supporto



LEYLE

026-100-031

Spatelhalter
Support
Porta-espátula
Supporto



LEYLEA

026-110-001

Selbsthaltender Spatel mit 1 Spannarm, komplett, bestehend aus:
 1 Kugelgelenkkloben (026-110-010)
 1 Haltearm (026-110-020)
 1 Kupplungskopf (026-110-030)
 1 Spannarm (026-100-010)
 1 Spatelhalterung für Spatel mit rundem Griff (026-100-030)

Self-retaining retractor with 1 flexible arm, complete, consisting of:
 1 Ball and socket joint (026-110-010)
 1 Holding rod (026-110-020)
 1 Coupling head (026-110-030)
 1 Flexible arm (026-100-010)
 1 Support, for spatulas with round shaft (026-100-030)

Separador automático con 1 brazo, completo, compuesto de:
 1 Articulación esférica (026-110-010)
 1 Brazo de apoyo (026-110-020)
 1 Acoplamiento (026-110-030)
 1 Brazo (026-100-010)
 1 Porta-espátula para espátulas con mangos redondos (026-100-030)

Autofissatore per retrattori con 1 braccio flessibile completo, composto da:
 1 Giunto a sfera ad incastro (026-110-010)
 1 Porta asta (026-110-020)
 1 Testa accoppiamento (026-110-0310)
 1 Braccio flessibile (026-100-010)
 1 Supporto per spatola con albero rotondo (026-100-030)

LEYLEA

026-110-002

Selbsthaltender Spatel mit 2 Spannarmen, komplett, bestehend aus:
 1 Kugelgelenkkloben (026-110-010)
 1 Haltearm (026-110-020)
 1 Kupplungsköpfe (026-110-030)
 2 Spannarme (026-100-010)
 2 Spatelhalterung, für flache Spatel (026-100-031)
 1 Spatel (026-127-009)
 1 Spatel (026-127-012)

Self-retaining retractor with 2 flexible arms, complete, consisting of:
 1 Ball and socket joint (026-110-010)
 1 Holding rod (026-110-020)
 1 Coupling heads (026-110-030)
 2 Flexible arms (026-100-010)
 2 Supports, for flat spatulas (026-100-31)
 1 spatulas (026-127-009)
 1 spatulas (026-127-012)

Separador automático con 2 brazos, completo, compuesto de:
 1 Articulación esférica (026-110-010)
 1 Brazo de apoyo (026-110-020)
 1 Acoplamientos (026-110-030)
 2 Brazos (026-100-010)
 2 Porta-espátula, para espátula planas (026-100-31)
 1 Espatula (026-127-009)
 1 Espatula (026-127-012)

Autofissatore per retrattori con 2 bracci flessibili completo, composto da:
 1 Giunto a sfera ad incastro (026-110-010)
 1 Porta asta (026-110-020)
 1 Testa accoppiamento (026-110-030)
 2 Bracci flessibili (026-100-010)
 2 Supporti per spatola piatta (026-100-031)
 1 Spatola (026-127-009)
 1 Spatola (026-127-012)



026

Zubehör zu LEYLA-Retraktoren
Accessories for LEYLA Self-Retaining Retractors
Accesorios para separadores automáticos de LEYLA
Accessori per autofissatori di retrattori di LEYLA

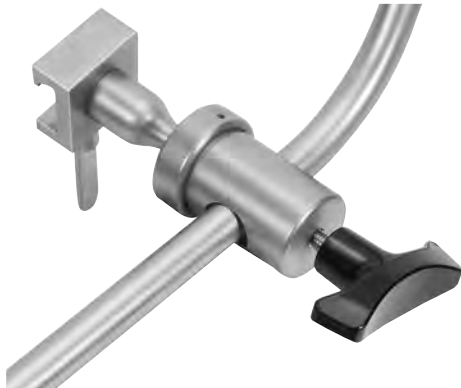

LEYLA

026-110-010

Kugelgelenkkloben
Ball and socket joint
Articulación esférica
Giunto a sfera ad incastro



LEYLA

026-110-020

Haltearm
Holding rod
Brazo
Porta asta



LEYLA

026-110-030

Kupplungskopf
Coupling head
Acoplamiento
Testa accoppiamento



LEYLA

026-110-031

Kupplungskopf, drehbar
Coupling head, turnable
Acoplamiento, girable
Testa accoppiamento, girabile



HEIFETZ

026-121-008	8 x 200 mm
026-121-011	11 x 200 mm
026-121-014	14 x 200 mm
026-121-017	17 x 200 mm
026-121-020	20 x 200 mm



HEIFETZ

026-122-008	8 x 155mm
026-122-011	11 x 155 mm
026-122-014	14 x 155 mm
026-122-017	17 x 155 mm



biegsam
malleable
maleable
flessibile

DAVIS

026-125-013	13 x 190 mm
026-125-016	16 x 190 mm



biegsam / gerieft
malleable / serrated
maleable / acanalada
flessibile / scannalato

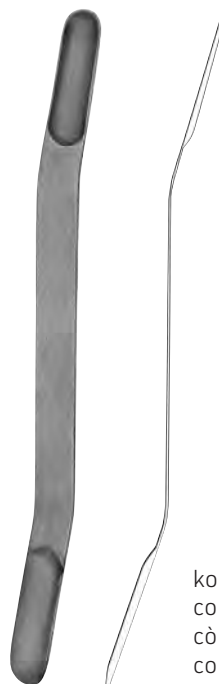

konkav
concave
còncava
concava

OLIVECRONA

026-127-009	9 x 200 mm
026-127-012	12 x 200 mm

026-131-001	7+9 mm x 180 mm
026-131-002	11+13 mm x 180 mm
026-131-003	15+18 mm x 180 mm
026-131-004	19+21 mm x 180 mm

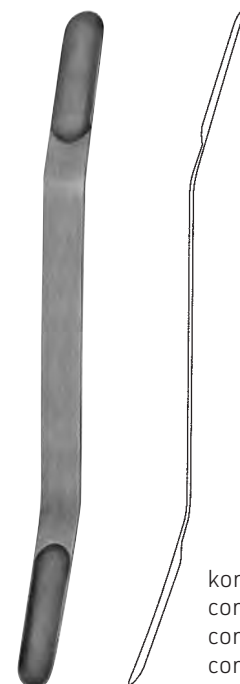

konvex
convex
convexa
convessa

OLIVECRONA

026-133-001	7+9 mm x 180 mm
026-133-002	11+13 mm x 180 mm
026-133-003	15+18 mm x 180 mm
026-133-004	19+21 mm x 180 mm



026

Nervwurzelnhaken
Nerve Root Retractors
Separadores para la raíz de nervios
Seperatori pr le radici dei nervi



SCOVILLE

026-140-230 23,0 cm / 9"



SCOVILLE

026-141-200 20,0 cm / 8"

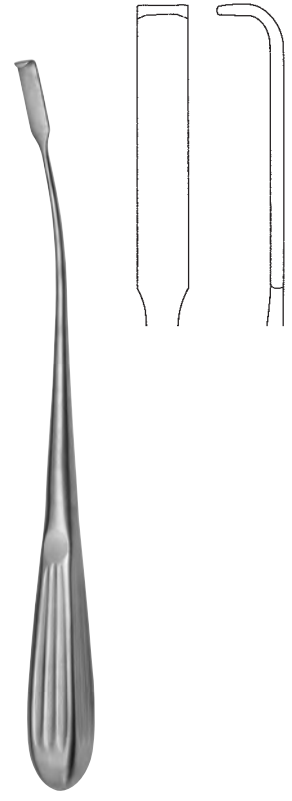

HOLSHER

026-143-240 24,0 cm / 9 1/2"



LOVE

026-146-190 19,0 cm / 7 1/2"

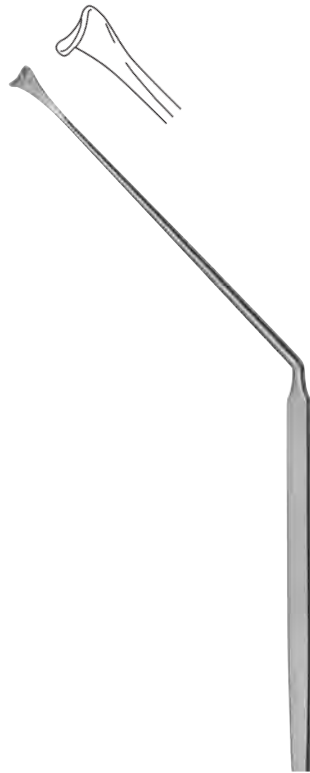

LOVE

026-147-180 18,0 cm / 7"

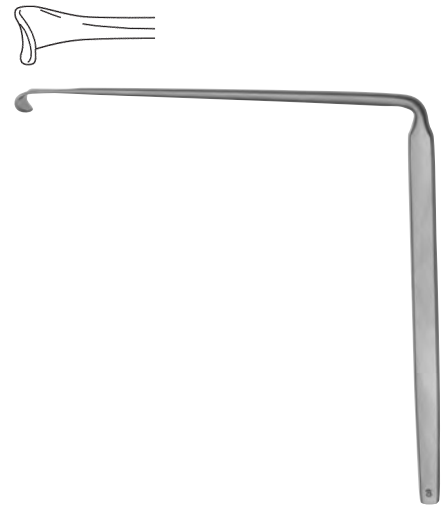

LOVE

026-149-140 14,0 cm / 5 1/2"



026-153-001

026-153-002

GRONINGEN

026-153-001 - 026-153-002 26,0 cm / 10¹/₄"



stumpf
 blunt
 romo
 smusso

CUSHING

026-155-190 19,0 cm / 7¹/₂"
 026-155-280 28,0 cm / 11"



stumpf
 blunt
 romo
 smusso

CUSHING

026-157-190 19,0 cm / 7¹/₂"
 026-157-280 28,0 cm / 11"



026

Dura-Separatoren
Dura Separators
Disecadores para dura-madre
Dissettori per la dura-madre



DANDY

026-159-200 20,0 cm / 8 1/2"

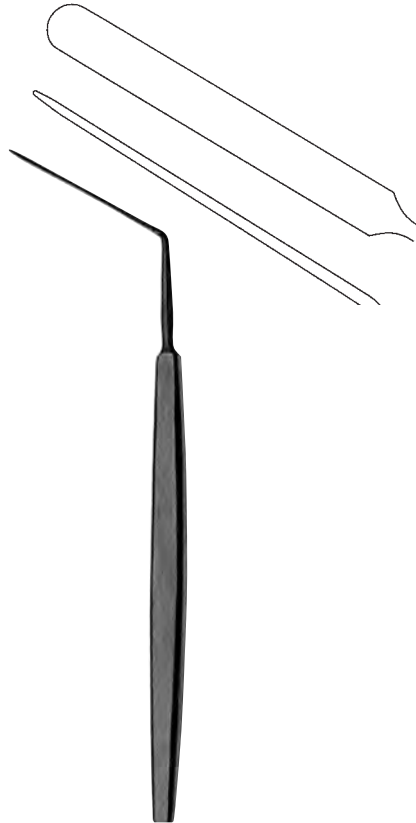

HORSLEY

026-161-200 20,0 cm / 7 1/4"



SACHS

026-163-210 21,0 cm / 9"



scharf
sharp
agudo
acuto

SACHS

026-165-210 21,0 cm / 8"

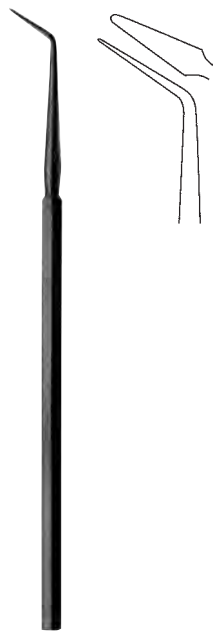

FRAZIER

026-167-165 16,5 cm / 6 1/2"



MILLIGAN

026-169-210 21,0 cm / 8 1/4"

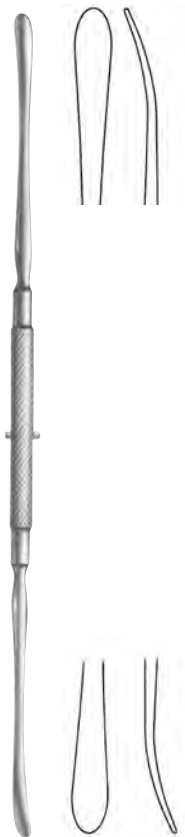

DAVIS
026-170-245 24,5 cm / 9²/₃"

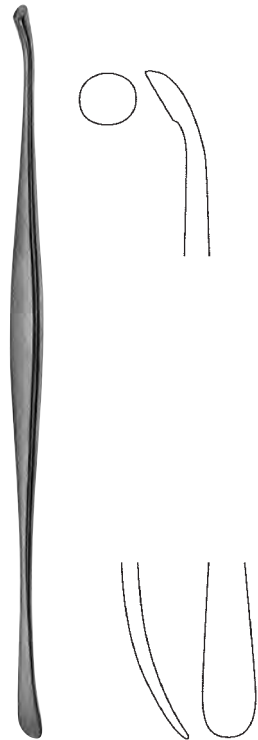

PENFIELD
026-171-001 17,5 cm / 7"



PENFIELD
026-171-002 19,5 cm / 7³/₄"

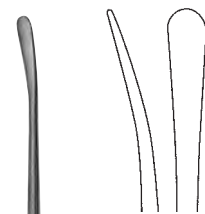

PENFIELD
026-171-003 19,5 cm / 7³/₄"



PENFIELD
026-171-215 21,5 cm / 8¹/₂"



PENFIELD
026-171-290 29,0 cm / 11¹/₂"



026

Dissektoren
Dissectors
Disecadores
Dissettori



schmal
small
estrecho
stretto

TOENNIS

026-173-001 24,0 cm / 9 1/2"



breit
large
ancho
largo

TOENNIS

026-173-002 24,0 cm / 9 1/2"

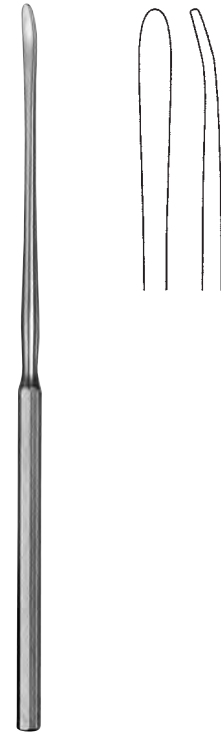

DAVIS

026-175-190 19,0 cm / 7 1/2"



schmall
small
estrecho
stretto

OLIVECRONA

026-177-180 18,0 cm / 7"
026-177-240 24,0 cm / 9 1/2"



breit
large
ancho
largo

OLIVECRONA

026-179-195 19,5 cm / 7 3/4"
026-179-240 24,0 cm / 9 1/2"

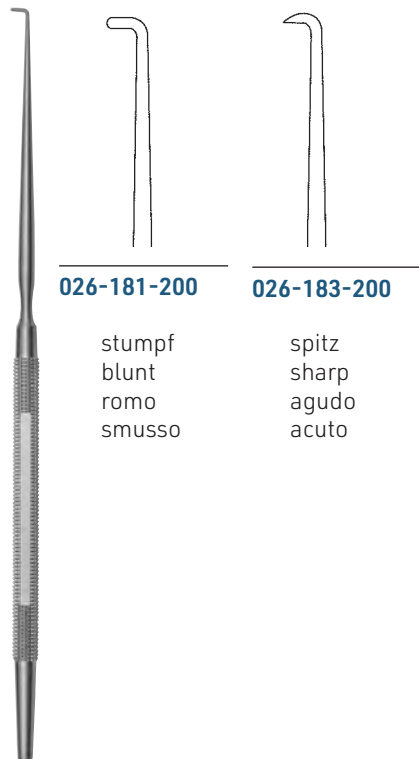

026-181-200

stumpf
 blunt
 romo
 smusso

026-183-200

spitz
 sharp
 agudo
 acuto

ADSON

026-181-200 - 026-183-200 20,0 cm / 8"

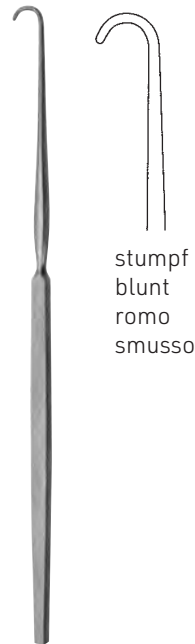

stumpf
 blunt
 romo
 smusso

GRAHAM

026-185-165 16,5 cm / 6³/₄"

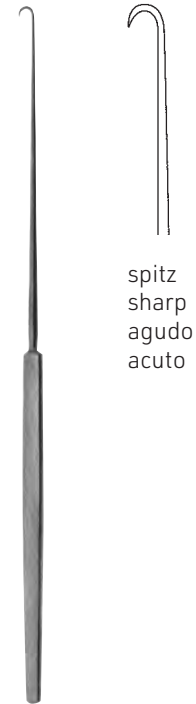

spitz
 sharp
 agudo
 acuto

SACHS

026-187-185 18,5 cm / 7¹/₄"



spitz
 sharp
 agudo
 acuto

FRAZIER

026-189-130 13,0 cm / 5"
026-189-180 18,0 cm / 7"



stumpf
 blunt
 romo
 smusso

FRAZIER

026-190-130 13,0 cm / 5"

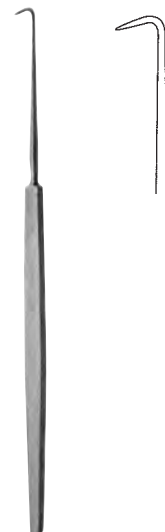

CUSHING

026-191-140 14,0 cm / 5¹/₂"



026

Messer, Haken
Knives, Hooks
Cuchillos, Ganchos
Bisturi, Uncini



TOENNIS
026-193-130 13,0 cm / 5 1/8"



TOENNIS
026-193-190 19,0 cm / 7 1/2"



HALLE
026-195-200 20,0 cm / 8 1/4"

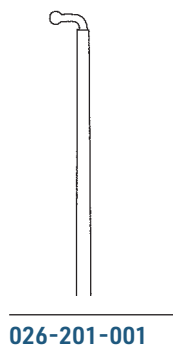

026-201-001



026-201-002



026-201-003



026-201-004

CASPAR
026-201-001 - 026-201-004 25,0 cm / 10"



026-203-020



026-203-025



026-203-030



026-203-035



KRAYENBÜHL
026-203-020 - 026-203-035 18,5 cm / 7 1/4"

Spekula für trans-sphenoidale Hypophysektomie
 Specula for trans-sphenoidal hypophysectomy
 Espéculo para la hipofisectomía trans-sfenoidal
 Speculo per ipofisectomia trans-sfenoidale



**LANDOLT-
 CUSHING**

026-210-070 ø 15 mm x 70 mm
026-210-090 ø 15 mm x 90 mm

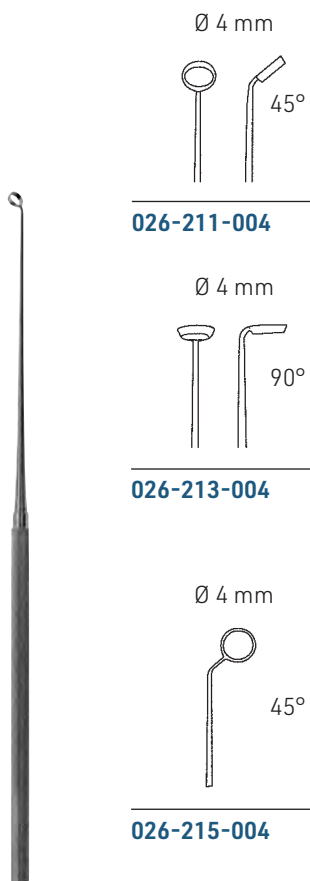

RAY

026-211-004 - 026-215-004 19,0 cm / 7 1/2"

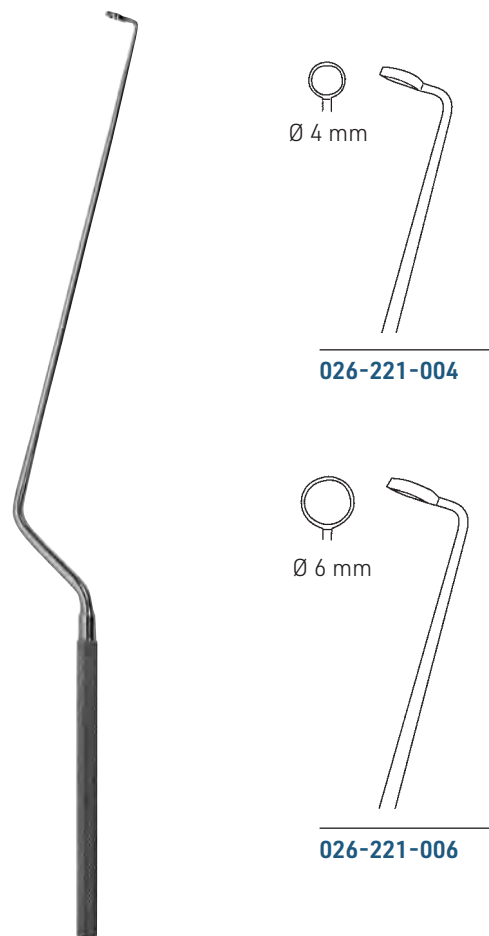

HARDY

026-221-004 - 026-221-006 26,0 cm / 10 1/4"

Küretten, horizontal 90°, biegsam
 Curettes, horizontal 90°, malleable
 Curetas, horizontal 90°, maleable
 Curette, orizzontale 90°, malleabile



026

Hypophysektomie-Instrumente
Pituitary Instruments
Instrumentos para la hipofisectomía
Strumenti per ipofisi



stumpf
blunt
romo
smusso

HARDY

026-231-001

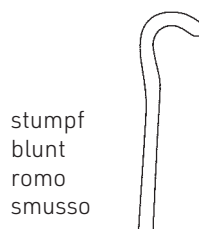

stumpf
blunt
romo
smusso

HARDY

026-231-002



scharf
sharp
agudo
acuto

HARDY

026-233-001



scharf
sharp
agudo
acuto

HARDY

026-233-002



HARDY

026-236-245



scharf
sharp
agudo
acuto

HARDY-FAHLBUSCH

026-237-001



scharf
sharp
agudo
acuto

HARDY-FAHLBUSCH

026-237-002

026-231-001 - 026-237-002 24,5 cm / 9³/₄"

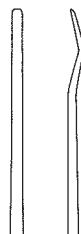

YASARGIL

026-251-001

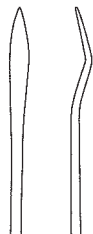

YASARGIL

026-251-002



YASARGIL

026-251-003



YASARGIL

026-251-004



YASARGIL

026-251-005



JACOBSON

026-251-006



JACOBSON

026-251-007



YASARGIL

026-251-008

026-251-001 - 026-251-008 19,0 cm / 7¹/₂"



026-261-001 - 026-267-002 19,0 cm / 7 1/4"

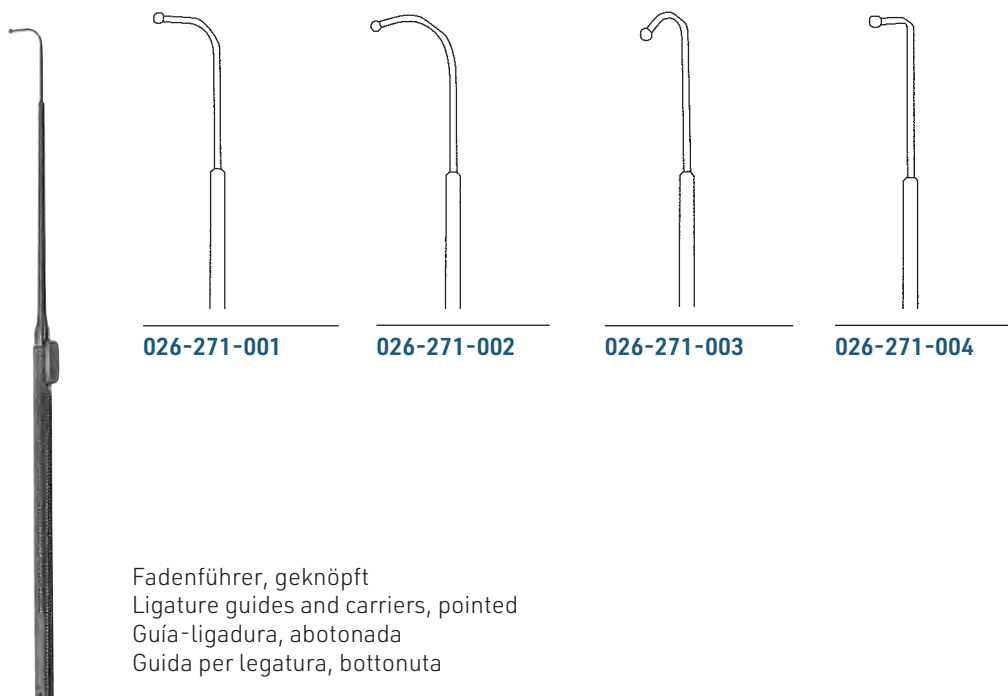

Fadenführer, geknöpft
 Ligature guides and carriers, pointed
 Guía-ligadura, abotonada
 Guida per legatura, bottonuta

YASARGIL
 026-271-001 - 026-271-004 18,5 cm / 7 1/4"



026

Mikro Instrumente
Micro Instruments
Instrumentos para microcirugia
Strumenti per microchirurgia



026-280-001



026-280-002



026-291-001

Dissektor
Dissector
Disecador
Dissettore

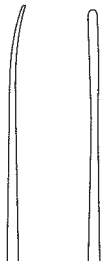

026-281-001



026-281-002



026-291-002

Dissektor
Dissector
Disecador
Dissettore

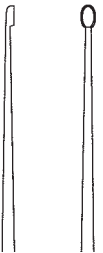

026-284-001



026-284-002

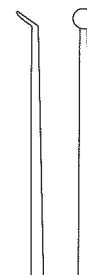

026-291-003

Raspatorium
Raspatory
Legra
Periostotomo

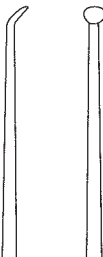

026-285-001



026-285-002

026-280-001 - 026-285-002 23,0 cm / 9"

026-291-001 - 026-291-003 23,0 cm / 9"

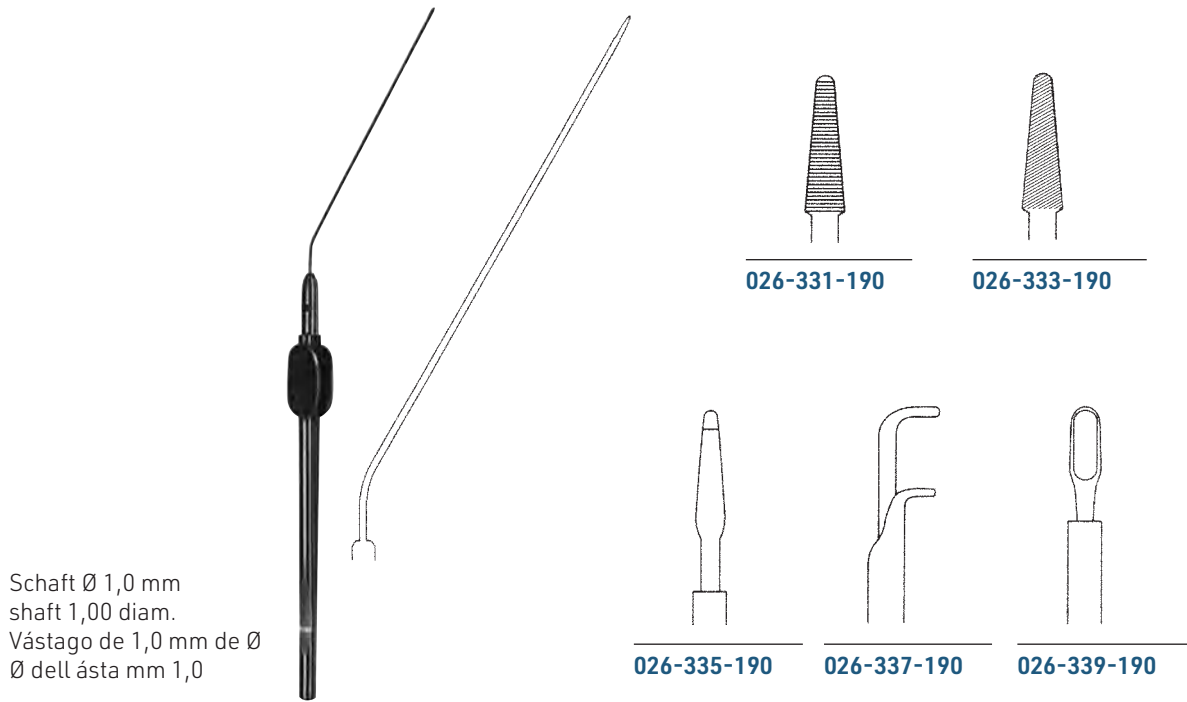

Schaft Ø 1,0 mm
 shaft 1,00 diam.
 Vástago de 1,0 mm de Ø
 Ø dell'asta mm 1,0

026-331-190 - 026-339-190 19,0 cm / 7 1/2"

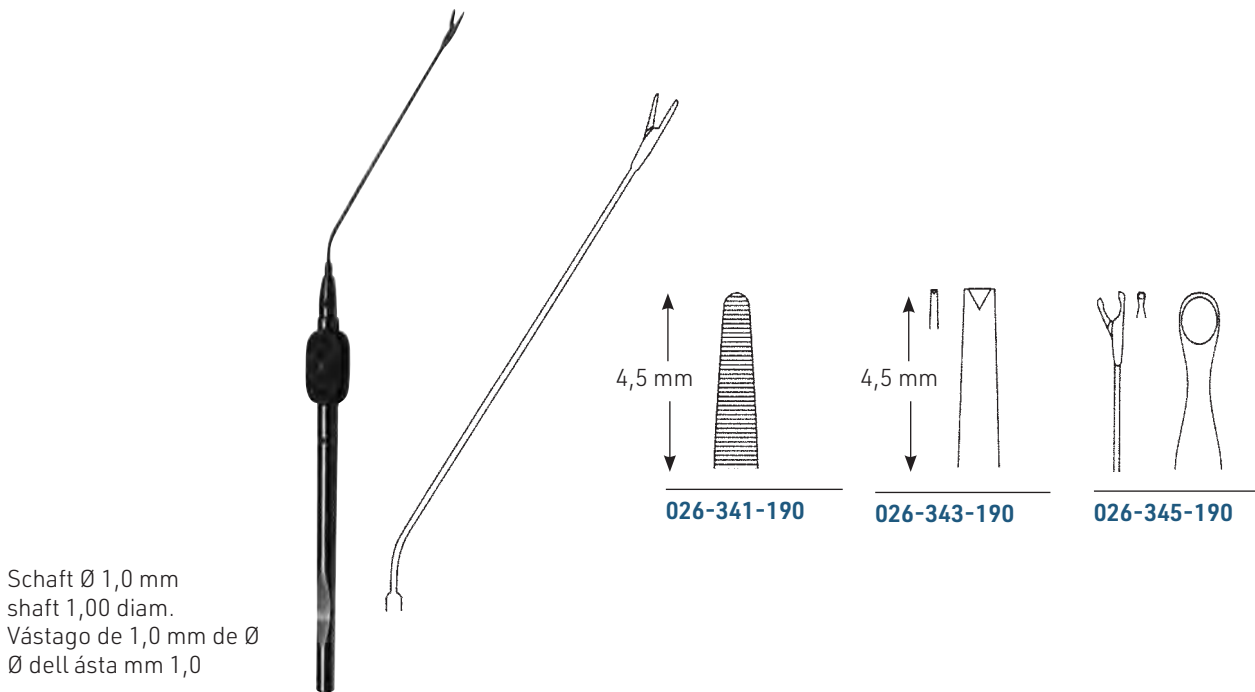

Schaft Ø 1,0 mm
 shaft 1,00 diam.
 Vástago de 1,0 mm de Ø
 Ø dell'asta mm 1,0

026-341-190 - 026-345-190 19,0 cm / 7 1/2"



026

Laminektomie-Spreizer
Laminectomy Retractors
Separadores para laminectomía
Divaricatori per laminectomia

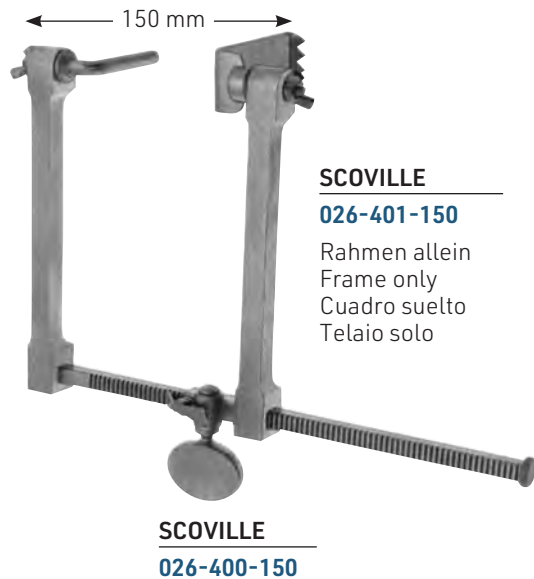

SCOVILLE

026-401-150

Rahmen allein
Frame only
Cuadro suelto
Telaio solo

SCOVILLE

026-400-150

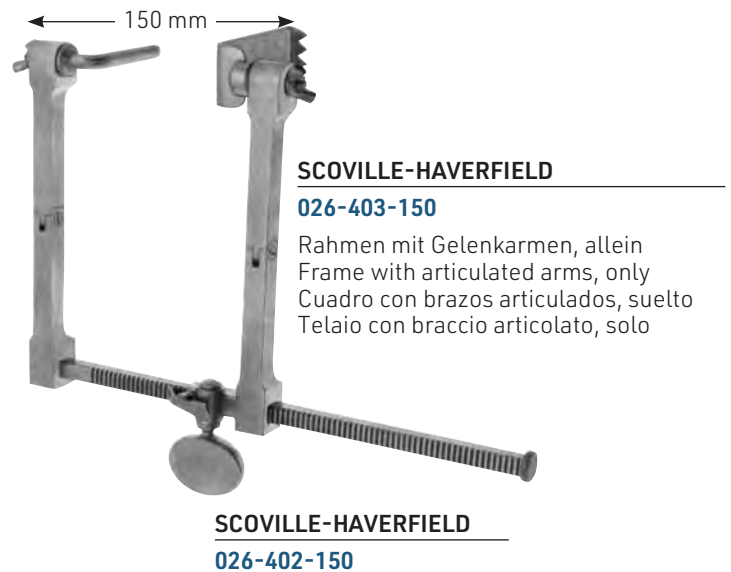

SCOVILLE-HAVERFIELD

026-403-150

Rahmen mit Gelenkarmen, allein
Frame with articulated arms, only
Cuadro con brazos articulados, suelto
Telaio con braccio articolato, solo

SCOVILLE-HAVERFIELD

026-402-150

Wundspreizer, komplett, bestehend aus:

- 1 Rahmen (026-401-150)
- 1 Haken 50 mm (026-403-050)
- 1 Seitenvalve 63 x 25 mm (a x b) (026-405-001)

Self-retaining retractor, complete, consisting of:

- 1 Frame (026-401-150)
- 1 Hook 50 mm (026-403-050)
- 1 Lateral valve 63 x 25 mm (a x b) (026-405-001)

Separador, completo, compuesto de:

- 1 Cuadro (026-403-050)
- 1 Gancho 50 mm (026-403-050)
- 1 Valva lateral 63 x 25 mm (a x b) (026-405-001)

Divaricatore, completo, composto da:

- 1 Telaio (026-403-050)
- 1 Divaricatore 50 mm (026-403-050)
- 1 Valva laterale 63 x 25 mm (a x b) (026-405-001)

Wundspreizer, komplett, bestehend aus:

- 1 Rahmen (026-403-150)
- 1 Haken 50 mm (026-403-050)
- 1 Seitenvalve 63 x 25 mm (a x b) (026-405-001)

Self-retaining retractor, complete, consisting of:

- 1 Frame (026-403-150)
- 1 Hook 50 mm (026-403-050)
- 1 Lateral valve 63 x 25 mm (a x b) (026-405-001)

Separador, completo, compuesto de:

- 1 Cuadro (026-403-150)
- 1 Gancho 50 mm (026-403-050)
- 1 Valva lateral 63 x 25 mm (a x b) (026-405-001)

Divaricatore, completo, composto da:

- 1 Telaio (026-403-150)
- 1 Divaricatore 50 mm (026-403-050)
- 1 Valva laterale 63 x 25 mm (a x b) (026-405-001)



SCOVILLE

- 026-403-050** 50,0 mm
- 026-403-075** 75,0 mm

Haken für Wundspreizer
 (026-400-150 und 026-402-150)
 Hooks for self-retaining retractors
 (026-400-150 und 026-402-150)
 Ganchos para separadores
 (026-400-150 und 026-402-150)
 Gancio per divaricatori
 (026-400-150 und 026-402-150)

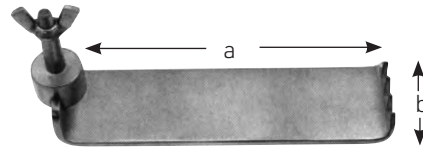

SCOVILLE

- 026-405-001** 63 x 25 mm (a x b)
- 026-405-002** 64 x 50 mm (a x b)
- 026-405-003** 88 x 25 mm (a x b)

Seitenvalven für Wundspreizer
 (026-400-150 und 026-402-150)
 Lateral valves for self-retaining
 (026-400-150 und 026-402-150)
 Valvas laterales para separadores
 (026-400-150 und 026-402-150)
 Valve laterali per divaricatori
 (026-400-150 und 026-402-150)

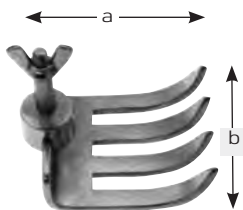

SCOVILLE

- 026-407-038** 41 x 38 mm (a x b)
- 026-407-044** 67 x 44 mm (a x b)

Seitenvalven für Wundspreizer
 (026-400-150 und 026-402-150)
 Lateral valves for self-retaining
 (026-400-150 und 026-402-150)
 Valvas laterales para separadores
 (026-400-150 und 026-402-150)
 Valve laterali per divaricatori
 (026-400-150 und 026-402-150)

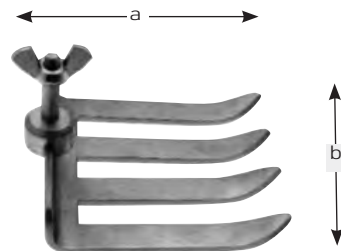

TAYLOR

- 026-409-001** 48 x 50 mm (a x b)
- 026-409-002** 64 x 64 mm (a x b)
- 026-409-003** 80 x 57 mm (a x b)

Seitenvalven für Wundspreizer
 (026-400-150 und 026-402-150)
 Lateral valves for self-retaining
 (026-400-150 und 026-402-150)
 Valvas laterales para separadores
 (026-400-150 und 026-402-150)
 Valve laterali per divaricatori
 (026-400-150 und 026-402-150)



026

Laminektomie-Spreizer
Laminectomy Retractors
Separadores para laminectomía
Divaricatori per laminectomia

Wundspreizer, Seitenvalven 52 x 44 mm (a x b)
Self-retaining retractor, lateral valves 52 x 44 mm (a x b)
Separador, valvas laterales 52 x 44 mm (a x b)
Divaricatore, Valve laterali 52 x 44 mm (a x b)

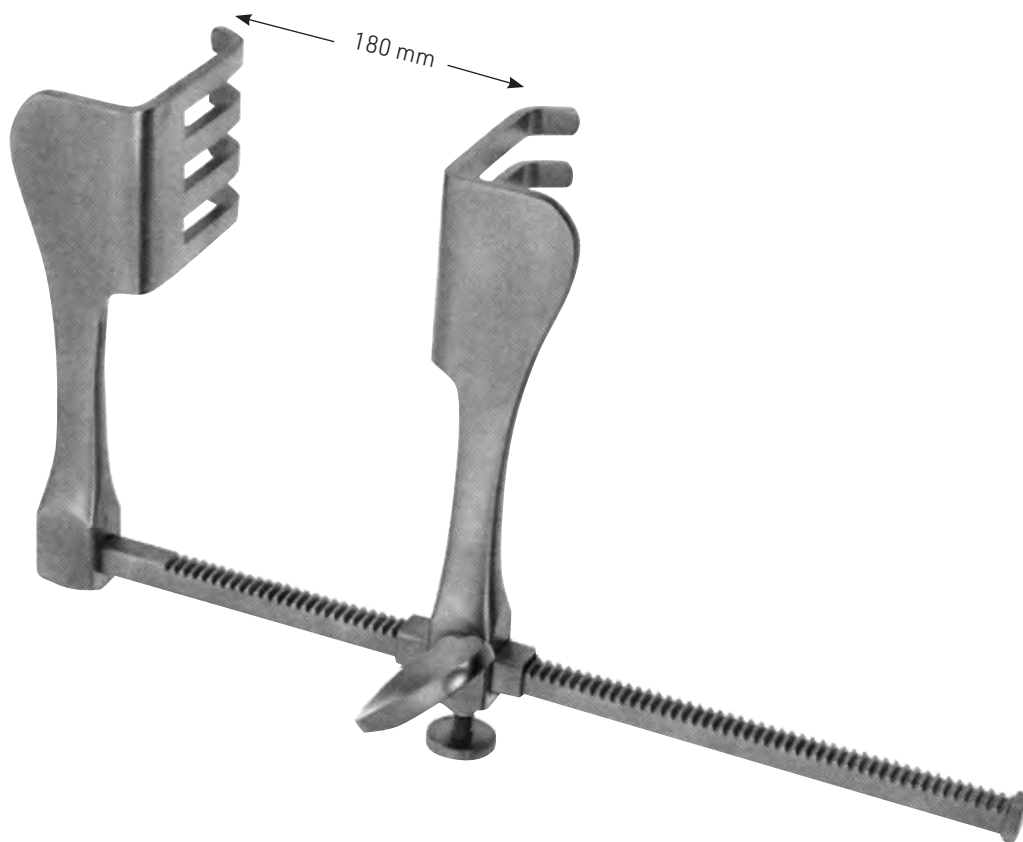

BADGLEY
026-410-180

Lumbal, thorakal und cervical einzusetzen!
 For use of lumbar, thoracic and cervical!
 Útil para lumbar, toracal y cervical!
 Per impiego lombare, toracico e cervicale



CASPAR

026-420-145

Wundspreizer mit Gelenkarmen und Kugelschnellverschluß, für Laminektomie und Hemi-Laminektomie, komplett, bestehend aus:
 1 Rahmen (026-421-145)
 1 Drehschlüssel (026-422-001)
 1 Haken 38 mm (026-423-038)
 1 Seitenvalve 37 x 22 mm (026-425-037)
 1 Seitenvalve 43 x 22 mm (026-425-043)
 1 Seitenvalve 47 x 22 mm (026-425-047)
 1 Seitenvalve 52 x 22 mm (026-425-052)
 1 Seitenvalve 57 x 22 mm (026-425-057)

Separador con brazos articulados y cierre rápido esférico, para laminectomia y hemilaminectomia, completo, compuesto de:
 1 Cuadro (026-421-145)
 1 Llave (026-422-001)
 1 Gancho 38 mm (026-423-038)
 1 Valva lateral 37 x 22 mm (026-425-037)
 1 Valva lateral 43 x 22 mm (026-425-043)
 1 Valva lateral 47 x 22 mm (026-425-047)
 1 Valva lateral 52 x 22 mm (026-425-052)
 1 Valva lateral 57 x 22 mm (026-425-057)

026-421-145

Rahmen mit Gelenkarmen, allein
 Frame with articulated arms, only
 Cuadro con brazos articulados, suelto
 Telaio con braccio articolato, solo

Self-retaining retractor with articulated arms and ball snap closure, for laminectomy and hemi-laminectomy, complete, consisting of:
 1 Frame (026-421-145)
 1 Key (026-422-001)
 1 Hook 38 mm (243-351-38)
 1 Lateral valve 37 x 22 mm (026-425-037)
 1 Lateral valve 43 x 22 mm (026-425-043)
 1 Lateral valve 47 x 22 mm (026-425-047)
 1 Lateral valve 52 x 22 mm (026-425-052)
 1 Lateral valve 57 x 22 mm (026-425-057)

Divaricatore con braccio articolato a chiusura istantanea, per laminectomia e emi-laminectomia, completo, composto da:
 1 Telaio (026-421-145)
 1 Chiave (026-422-001)
 1 Gancio 38 mm (243-351-38)
 1 Valva laterale 37 x 22 mm (026-425-037)
 1 Valva laterale 43 x 22 mm (026-425-043)
 1 Valva laterale 47 x 22 mm (026-425-047)
 1 Valva laterale 52 x 22 mm (026-425-052)
 1 Valva laterale 57 x 22 mm (026-425-057)



026-422-001

Drehschlüssel
 Key
 Llave
 chiave



026-423-038 38,0 mm



026-425-037 37 x 22 mm (a x b)

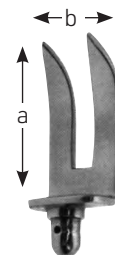

026-425-043 43 x 22 mm (a x b)



026-425-047 47 x 22 mm (a x b)



026-425-052 52 x 22 mm (a x b)



026-425-057 57 x 22 mm (a x b)



026

Haken, Seitenvalven
Hooks, Lateral Valves
Ganchos, Valvas laterales
Ganci, Valve laterali



026-423-038 38,0 mm
026-423-058 58,0 mm

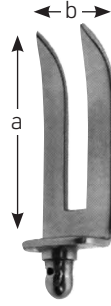

026-425-032 32 mm x 22 mm (a x b)
026-425-037 37 mm x 22 mm (a x b)
026-425-043 43 mm x 22 mm (a x b)
026-425-047 47 mm x 22 mm (a x b)
026-425-052 52 mm x 22 mm (a x b)
026-425-057 57 mm x 22 mm (a x b)
026-425-062 62 mm x 22 mm (a x b)
026-425-067 67 mm x 22 mm (a x b)



026-427-032 32 mm x 37 mm (a x b)
026-427-037 37 mm x 37 mm (a x b)
026-427-043 43 mm x 37 mm (a x b)
026-427-047 47 mm x 37 mm (a x b)
026-427-052 52 mm x 37 mm (a x b)
026-427-057 57 mm x 37 mm (a x b)
026-427-062 62 mm x 37 mm (a x b)
026-427-067 67 mm x 37 mm (a x b)



026-429-032 32 mm x 52 mm (a x b)
026-429-037 37 mm x 52 mm (a x b)
026-429-043 43 mm x 52 mm (a x b)
026-429-047 47 mm x 52 mm (a x b)
026-429-052 52 mm x 52 mm (a x b)
026-429-057 57 mm x 52 mm (a x b)
026-429-062 62 mm x 52 mm (a x b)
026-429-067 67 mm x 52 mm (a x b)



026-430-115 11,5 cm / 4 1/2"
Pinzette zum Valvenwechsel bei
Kugelschnellverschluß-System
Valve ejector for changing the valves
with ball snap closure system
Pinza para el cambio de valvas con el
sistema de cierre rapido esférico
Pinza per il cambio delle valve a
chiusura istantanea

CASPAR

026-440-090



Wundspreizer mit Gelenkarmen und Kugelschnellverschluß, komplett, bestehend aus:
 1 Rahmen (026-441-090)

- 1 medialen Valve 40 x 23 mm (026-443-040)
- 1 medialen Valve 45 x 23 mm (026-443-045)
- 1 medialen Valve 50 x 23 mm (026-443-050)
- 1 medialen Valve 55 x 23 mm (026-443-055)
- 1 medialen Valve 60 x 23 mm (026-443-060)
- 1 lateralen Valve 40 x 23 mm (026-445-040)
- 1 lateralen Valve 45 x 23 mm (026-445-045)
- 1 lateralen Valve 50 x 23 mm (026-445-050)
- 1 lateralen Valve 55 x 23 mm (026-445-055)
- 1 lateralen Valve 60 x 23 mm (026-445-060)

Self-retaining retractor with articulated arms and ball snap closure, complete, consisting of:
 1 Frame (026-441-090)

- 1 Medial valve 40 x 23 mm (026-443-040)
- 1 Medial valve 45 x 23 mm (026-443-045)
- 1 Medial valve 50 x 23 mm (026-443-050)
- 1 Medial valve 55 x 23 mm (026-443-055)
- 1 Medial valve 60 x 23 mm (026-443-060)
- 1 Lateral valve 40 x 23 mm (026-445-040)
- 1 Lateral valve 45 x 23 mm (026-445-045)
- 1 Lateral valve 50 x 23 mm (026-445-050)
- 1 Lateral valve 55 x 23 mm (026-445-055)
- 1 Lateral valve 60 x 23 mm (026-445-060)

Separador con brazos articulados y cierre rápido esférico, completo, compuesto de:
 1 Cuadro (026-441-090)

- 1 Valva mediana 40 x 23 mm (026-443-040)
- 1 Valva mediana 45 x 23 mm (026-443-045)
- 1 Valva mediana 50 x 23 mm (026-443-050)
- 1 Valva mediana 55 x 23 mm (026-443-055)
- 1 Valva mediana 60 x 23 mm (026-443-060)
- 1 Valva lateral 40 x 23 mm (026-445-040)
- 1 Valva lateral 45 x 23 mm (026-445-045)
- 1 Valva lateral 50 x 23 mm (026-445-050)
- 1 Valva lateral 55 x 23 mm (026-445-055)
- 1 Valva lateral 60 x 23 mm (026-445-060)

Divaricatore con braccio articolato a chiusura istantanea, completo, composto da:
 1 Telaio (026-441-090)

- 1 Valva media 40 x 23 mm (026-443-040)
- 1 Valva media 45 x 23 mm (026-443-045)
- 1 Valva media 50 x 23 mm (026-443-050)
- 1 Valva media 55 x 23 mm (026-443-055)
- 1 Valva media 60 x 23 mm (026-443-060)
- 1 Valva laterale 40 x 23 mm (026-445-040)
- 1 Valva laterale 45 x 23 mm (026-445-045)
- 1 Valva laterale 50 x 23 mm (026-445-050)
- 1 Valva laterale 55 x 23 mm (026-445-055)
- 1 Valva laterale 60 x 23 mm (026-445-060)

026-441-090

Rahmen mit Gelenkarmen, allein
 Frame with articulated arms, only
 Cuadro con brazos articulados, suelto
 Telaio con braccio articolato, solo

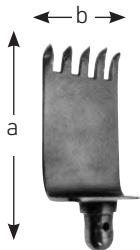

026-443-040
 40 x 23 mm (a x b)



026-443-045
 45 x 23 mm (a x b)



026-443-050
 50 x 23 mm (a x b)



026-443-055
 55 x 23 mm (a x b)



026-443-060
 60 x 23 mm (a x b)



026-445-040
 40 x 23 mm (a x b)



026-445-045
 45 x 23 mm (a x b)



026-445-050
 50 x 23 mm (a x b)



026-445-055
 55 x 23 mm (a x b)



026-445-060
 60 x 23 mm (a x b)

Wundspreizer für die cervicale Wirbelsäule
 Retractors for cervical spine
 Separadores para la columna cervical
 Divaricatori per colonna cervicale

← 85 mm →



026-451-085

Sperrer allein
 Spreader only
 Seperador suelto
 Divaricatore solo

CASPAR

026-450-085 10,5 cm / 4¹/₄"

Wundspreizer mit Gelenkarmen und Kugelschnellverschluß-komplett, bestehend aus:
 1 Sperrer (026-451-085)
 1 stumpfe Valve 45 x 23 mm (026-463-045)
 1 stumpfe Valve 50 x 23 mm (026-463-050)
 1 stumpfe Valve 55 x 23 mm (026-463-055)
 1 stumpfe Valve 60 x 23 mm (026-463-060)
 1 stumpfe Valve 65 x 23 mm (026-463-065)

Self-retaining retractor with articulated arms and ball snap closure, complete, consisting of:
 1 Spreader (026-451-085)
 1 Blunt valve 45 x 23 mm (026-463-045)
 1 Blunt valve 50 x 23 mm (026-463-050)
 1 Blunt valve 55 x 23 mm (026-463-055)
 1 Blunt valve 60 x 23 mm (026-463-060)
 1 Blunt valve 65 x 23 mm (026-463-065)

Seperador con brazos articulados y cierre rápido esférico, completo compuesto de:
 1 Separador (026-451-085)
 1 Valva roma 45 x 23 mm (026-463-045)
 1 Valva roma 50 x 23 mm (026-463-050)
 1 Valva roma 55 x 23 mm (026-463-055)
 1 Valva roma 60 x 23 mm (026-463-060)
 1 Valva roma 65 x 23 mm (026-463-065)

Divaricatore con braccio articolato a chiusura istantanea, completo, composto da:
 1 Divaricatore (026-451-085)
 1 Valva smussa 45 x 23 mm (026-463-045)
 1 Valva smussa 50 x 23 mm (026-463-050)
 1 Valva smussa 55 x 23 mm (026-463-055)
 1 Valva smussa 60 x 23 mm (026-463-060)
 1 Valva smussa 65 x 23 mm (026-463-065)

In Wirbelsäulen-Längsachse zu verwenden!
 To be used for up and down retraction!
 Útil para el eje longitudinal de la columna vertebral!
 Da impiegarsi per la trazione e la compressione della colonna!

← 90 mm →



026-461-090

Sperrer allein
 Spreader only
 Seperador suelto
 Divaricatore solo

CASPAR

026-460-090 16,5 cm / 6¹/₂"

Wundspreizer mit Gelenkarmen und Kugelschnellverschluß-komplett, bestehend aus:
 1 Sperrer (026-461-090)
 1 stumpfe Valve 45 x 23 mm (026-463-045)
 1 stumpfe Valve 50 x 23 mm (026-463-050)
 1 stumpfe Valve 55 x 23 mm (026-463-055)
 1 stumpfe Valve 60 x 23 mm (026-463-060)
 1 stumpfe Valve 65 x 23 mm (026-463-065)

Self-retaining retractor with articulated arms and ball snap closure, complete, consisting of:
 1 Spreader (026-461-090)
 1 Blunt valve 45 x 23 mm (026-463-045)
 1 Blunt valve 50 x 23 mm (026-463-050)
 1 Blunt valve 55 x 23 mm (026-463-055)
 1 Blunt valve 60 x 23 mm (026-463-060)
 1 Blunt valve 65 x 23 mm (026-463-065)

Seperador con brazos articulados y cierre rápido esférico, completo compuesto de:
 1 Separador (026-461-090)
 1 Valva roma 45 x 23 mm (026-463-045)
 1 Valva roma 50 x 23 mm (026-463-050)
 1 Valva roma 55 x 23 mm (026-463-055)
 1 Valva roma 60 x 23 mm (026-463-060)
 1 Valva roma 65 x 23 mm (026-463-065)

Divaricatore con braccio articolato a chiusura istantanea, completo, composto da:
 1 Divaricatore (026-461-090)
 1 Valva smussa 45 x 23 mm (026-463-045)
 1 Valva smussa 50 x 23 mm (026-463-050)
 1 Valva smussa 55 x 23 mm (026-463-055)
 1 Valva smussa 60 x 23 mm (026-463-060)
 1 Valva smussa 65 x 23 mm (026-463-065)

Valven, stumpf
Valves, blunt
Valvas, romas
Valve, smusso



026

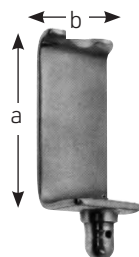

026-463-045

45 x 23 mm (a x b)



026-463-050

50 x 23 mm (a x b)



026-463-055

55 x 23 mm (a x b)



026-463-060

60 x 23 mm (a x b)



026-463-065

65 x 23 mm (a x b)



026-465-050

50 x 25 mm (a x b)



026-465-060

60 x 25 mm (a x b)

← 60 mm →

Oberfläche geschwärzt
 Surface black-finish
 Superficie negra
 Superficie nera



026-471-060

Rahmen mit Gelenkarmen, allein
 Frame with articulated arms, only
 Cuadro con brazos articulados, suelto
 Relais con braccio articolato, solo

CASPAR

026-470-060

Wundspreizer mit Gelenkarmen und Kugelschnellverschluß-komplett, bestehend aus:

- 1 Rahmen (026-471-060)
- 1 Seitenvalve 35 x 12 mm (026-473-035)
- 1 Seitenvalve 40 x 13 mm (026-473-040)
- 1 Seitenvalve 45 x 13 mm (026-473-045)
- 1 Seitenvalve 50 x 14 mm (026-473-050)
- 1 Seitenvalve 55 x 14 mm (026-473-055)
- 1 Seitenvalve 60 x 15 mm (026-473-060)

Seperador con brazos articulados y cierre rápido esférico, completo compuesto de:

- 1 Cuadro (026-471-060)
- 1 Valva lateral 35 x 12 mm (026-473-035)
- 1 Valva lateral 40 x 13 mm (026-473-040)
- 1 Valva lateral 45 x 13 mm (026-473-045)
- 1 Valva lateral 50 x 14 mm (026-473-050)
- 1 Valva lateral 55 x 14 mm (026-473-055)
- 1 Valva lateral 60 x 15 mm (026-473-060)

Self-retaining retractor with articulated arms and ball snap closure, complete, consisting of:

- 1 Frame (026-461-060)
- 1 Lateral valve 35 x 12 mm (026-473-035)
- 1 Lateral valve 40 x 13 mm (026-473-040)
- 1 Lateral valve 45 x 13 mm (026-473-045)
- 1 Lateral valve 50 x 14 mm (026-473-050)
- 1 Lateral valve 55 x 14 mm (026-473-055)

Divaricatore con braccio articolato a chiusura istantanea, completo, composto da:

- 1 Telaio (026-461-060)
- 1 Valva laterale 35 x 12 mm (026-473-035)
- 1 Valva laterale 40 x 13 mm (026-473-040)
- 1 Valva laterale 45 x 13 mm (026-473-045)
- 1 Valva laterale 50 x 14 mm (026-473-050)
- 1 Valva laterale 55 x 14 mm (026-473-055)

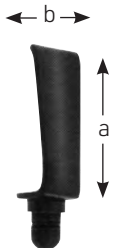

026-473-035

35 x 12 mm (a x b)

026-473-040

40 x 13 mm (a x b)

026-473-045

45 x 13 mm (a x b)

026-473-050

50 x 14 mm (a x b)

026-473-055

55 x 14 mm (a x b)

026-473-060

60 x 15 mm (a x b)



Oberfläche geschwärzt
 Surface black-finish
 Superficie negra
 Superficie nera

CASPAR

026-481-040 - 026-481-060 15,0 cm / 6"

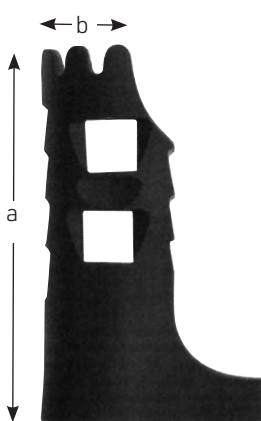

026-481-040
 40 x 18 mm (a x b)



026-481-045
 45 x 18 mm (a x b)



026-481-050
 50 x 18 mm (a x b)



026-481-055
 55 x 18 mm (a x b)



026-481-060
 60 x 18 mm (a x b)

Wirbelkörperspreizer
 Lamina Spreaders
 Separadores para cuerpos vertebrales
 Separatori per vertebre

Spreizweite 18 mm
 Blade opening 18 mm
 Abertura de la hoja 18 mm
 Apertura lame 18 mm



CLOWARD
 026-491-130 13,0 cm / 5 1/8"

Spreizweite 18 mm
 Blade opening 18 mm
 Abertura de la hoja 18 mm
 Apertura lame 18 mm



CLOWARD
 026-493-160 16,0 cm / 6 1/4"

Spreizweite 38 mm
 Blade opening 38 mm
 Abertura de la hoja 38 mm
 Apertura lame 38 mm



INGE
 026-495-160 16,0 cm / 6 1/4"



INGE
 026-497-270 27,0 cm / 10 1/2"

Laminektomie-Stanzen nicht zerlegbar
 Laminectomy Punches non detachable
 Pinzas cortantes para laminectomia non desmontable
 Pinze per laminectomia non smontabile



026



Kleiner Griff
 Small handle
 Mango pequeno
 Manico piccolo

KERRISON

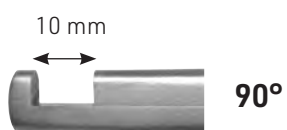

Schaftlänge Length of shaft Longitud del vástago Lunghezza dell' asta	Bissbreite / Width of bite / Anchura de la boca / Larghezza del morso					
	1 mm	2 mm	3 mm	4 mm	5 mm	6 mm
180 mm	026-550-001	026-550-002	026-550-003	026-550-004	026-550-005	026-550-006
200 mm	026-552-001	026-552-002	026-552-003	026-552-004	026-552-005	026-552-006
230 mm	-	026-554-002	026-554-003	026-554-004	026-554-005	-



026

Laminektomie-Stanzen	nicht zerlegbar
Laminectomy Punches	non detachable
Pinzas cortantes para laminectomia	non desmontable
Pinze per laminectomia	non smontabile

Dünnfuß (Mikro)
Thin footplate (Micro)
Lámin de punzonar estrecha (Micro)
Battente sottile (Micro)

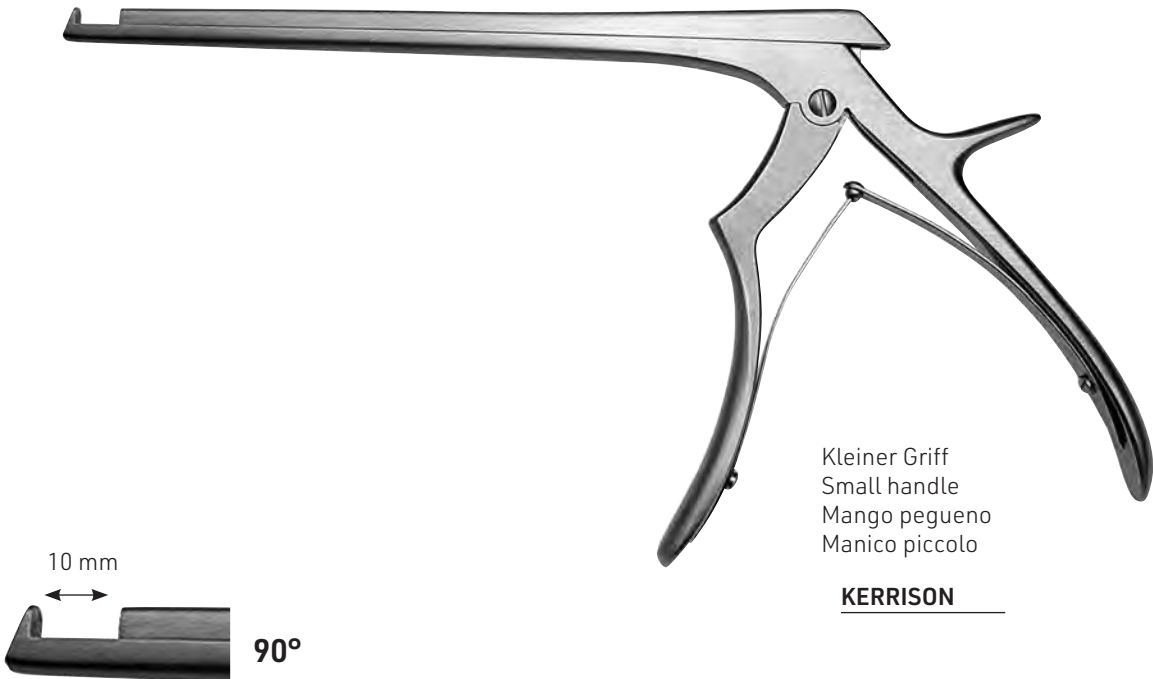

Kleiner Griff
Small handle
Mango pegueno
Manico piccolo

KERRISON

Schaftlänge Length of shaft Longitud del vástago Lunghezza dell' asta	Bissbreite / Width of bite / Anchura de la boca / Larghezza del morso				
	2 mm	3 mm	4 mm	5 mm	6 mm
180 mm	026-560-002	026-560-003	026-560-004	026-560-005	026-560-006
200 mm	026-562-002	026-562-003	026-562-004	026-562-005	026-562-006
230 mm	026-564-002	026-564-003	026-564-004	026-564-005	-

Laminektomie-Stanzen nicht zerlegbar
 Laminectomy Punches non detachable
 Pinzas cortantes para laminectomia non desmontable
 Pinze per laminectomia non smontabile



026



KERRISON

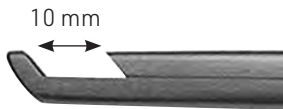

Schaftlänge Length of shaft Longitud del vástago Lunghezza dell`asta	Bissbreite / Width of bite / Anchura de la boca / Larghezza del morso					
	1 mm	2 mm	3 mm	4 mm	5 mm	6 mm
180 mm	026-570-001	026-570-002	026-570-003	026-570-004	026-570-005	026-570-006
200 mm	026-572-001	026-572-002	026-572-003	026-572-004	026-572-005	026-572-006
230 mm	-	026-574-002	026-574-003	026-574-004	026-574-005	-

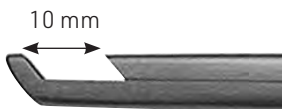

130° (40°)

mit Auswerfer
 with ejector
 con espulsor
 con espulsore

Schaftlänge Length of shaft Longitud del vástago Lunghezza dell`asta	Bissbreite / Width of bite / Anchura de la boca / Larghezza del morso		
	3 mm	4 mm	5 mm
180 mm	026-580-003	026-580-004	026-580-005
200 mm	026-582-003	026-582-004	026-582-005



026

Laminektomie-Stanzen nicht zerlegbar
 Laminectomy Punches non detachable
 Pinzas cortantes para laminectomia non desmontable
 Pinze per laminectomia non smontabile

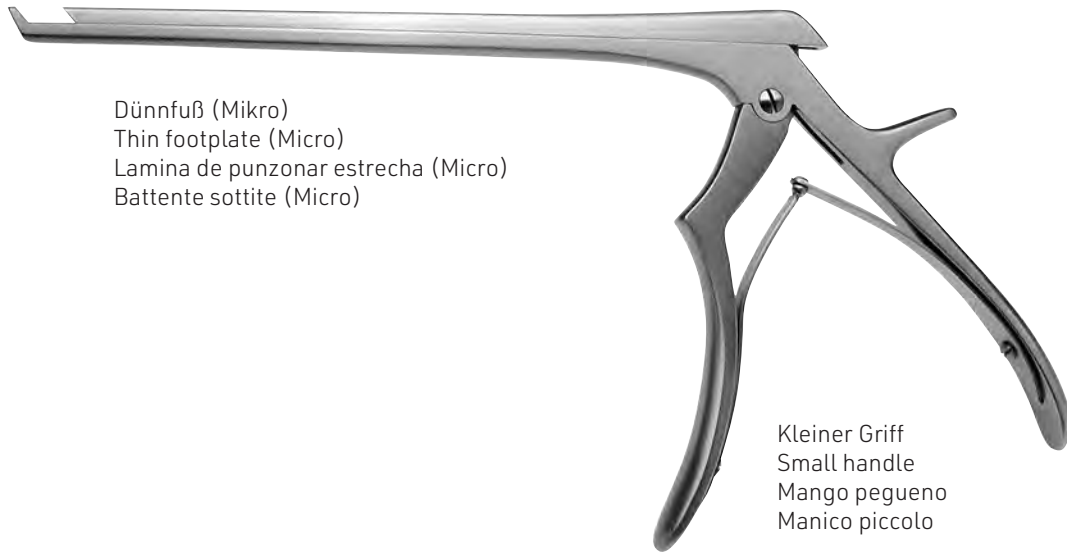

Dünnfuß (Mikro)
 Thin footplate (Micro)
 Lamina de punzonar estrecha (Micro)
 Battente sottile (Micro)

Kleiner Griff
 Small handle
 Mango pegueno
 Manico piccolo

KERRISON

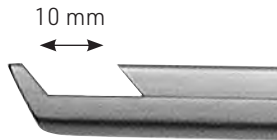

130° (40°)

Schaftlänge Length of shaft Longitud del vástago Lunghezza dell' asta	Bissbreite / Width of bite / Anchura de la boca / Larghezza del morso				
	2 mm	3 mm	4 mm	5 mm	6 mm
180 mm	026-590-002	026-590-003	026-590-004	026-590-005	026-590-006
200 mm	026-592-002	026-592-003	026-592-004	026-592-005	026-592-006
230 mm	026-594-002	026-594-003	026-594-004	026-594-005	-

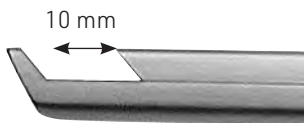

130° (40°)

mit Auswerfer
 with ejector
 con expulsor
 con espulsore

Schaftlänge Length of shaft Longitud del vástago Lunghezza dell' asta	Bissbreite / Width of bite / Anchura de la boca / Larghezza del morso		
	3 mm	4 mm	5 mm
180 mm	026-600-003	026-600-004	026-600-005
200 mm	026-602-003	026-602-004	026-602-005

Laminektomie-Stanzen nicht zerlegbar
 Laminectomy Punches non detachable
 Pinzas cortantes para laminectomia non desmontable
 Pinze per laminectomia non smontabile



026



Kleiner Griff
 Small handle
 Mango pegueno
 Manico piccolo

KERRISON



Standardfuß
 Standard footplate
 Lámin de punzonar standard
 Battente standard

Schaftlänge Length of shaft Longitud del vástago Lunghezza dell' asta	Bissbreite / Width of bite / Anchura de la boca / Larghezza del morso			
	2 mm	3 mm	4 mm	5 mm
180 mm	026-610-002	026-610-003	026-610-004	026-610-005
200 mm	026-612-002	026-612-003	026-612-004	026-612-005



Dünnfuß (Mikro)
 Thin footplate (Micro)
 Lámina de punzonar estrecha (Micro)
 Battente sottile

Schaftlänge Length of shaft Longitud del vástago Lunghezza dell' asta	Bissbreite / Width of bite / Anchura de la boca / Larghezza del morso			
	2 mm	3 mm	4 mm	5 mm
180 mm	026-620-002	026-620-003	026-620-004	026-620-005
200 mm	026-622-002	026-622-003	026-622-004	026-622-005



026

Laminektomie-Stanzen nicht zerlegbar
 Laminectomy Punches non detachable
 Pinzas cortantes para laminectomia non desmontable
 Pinze per laminectomia non smontabile

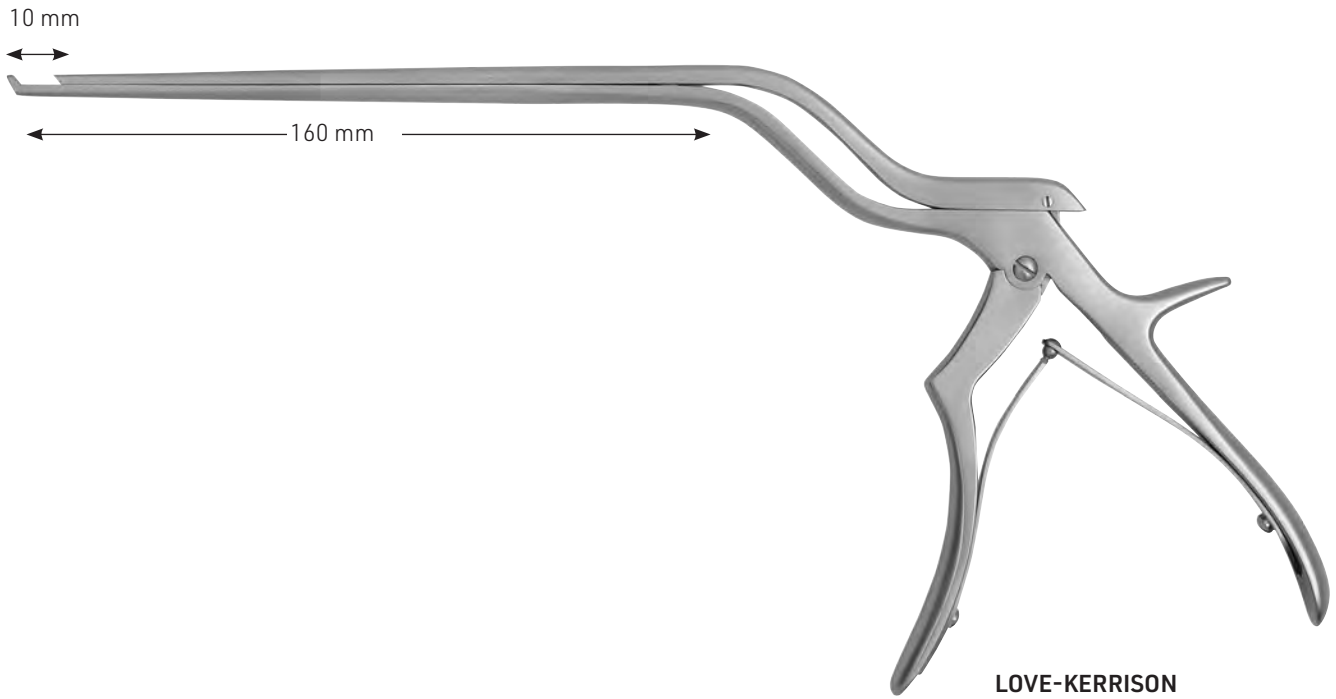

Standardfuß
 Standard footplate
 Lámin de punzonar standard
 Battente standard

Schaftlänge Length of shaft Longitud del vástago Lunghezza dell' asta	Bissbreite / Width of bite / Anchura de la boca / Larghezza del morso			
	2 mm	3 mm	4 mm	5 mm
160 mm	026-630-002	026-630-003	026-630-004	026-630-005



Dünfuß (Mikro)
 Thin footplate (Micro)
 Lámina de punzonar estrecha (Micro)
 Battente sottile

Schaftlänge Length of shaft Longitud del vástago Lunghezza dell' asta	Bissbreite / Width of bite / Anchura de la boca / Larghezza del morso			
	2 mm	3 mm	4 mm	5 mm
160 mm	026-640-002	026-640-003	026-640-004	026-640-005

Laminektomie-Stanzen nicht zerlegbar
 Laminectomy Punches non detachable
 Pinzas cortantes para laminectomia non desmontable
 Pinze per laminectomia non smontabile



026



Kleiner Griff
 Small handle
 Mango pegueno
 Manico piccolo

KERRISON



Schaftlänge Length of shaft Longitud del vástago Lunghezza dell' asta	Bissbreite / Width of bite / Anchura de la boca / Larghezza del morso				
	2 mm	3 mm	4 mm	5 mm	6 mm
180 mm	026-650-002	026-650-003	026-650-004	026-650-005	026-650-006
200 mm	026-652-002	026-652-003	026-652-004	026-652-005	026-652-006



026

Laminektomie-Stanzen nicht zerlegbar
Laminectomy Punches non detachable
Pinzas cortantes para laminectomia non desmontable
Pinze per laminectomia non smontabile

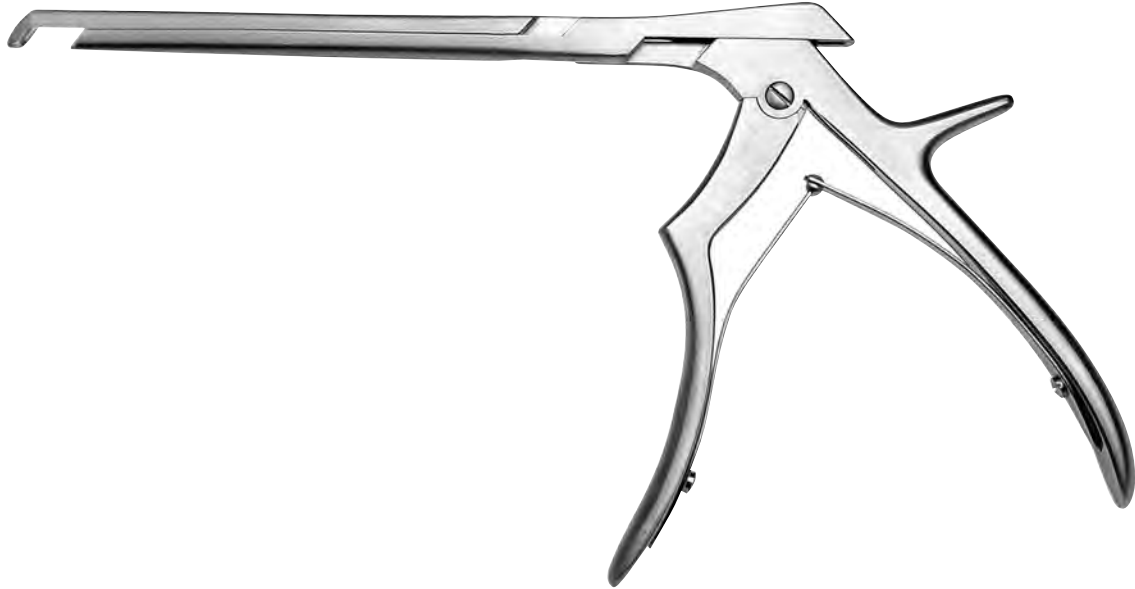

KERRISON

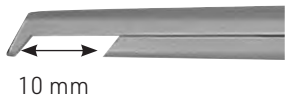

10 mm

130° (40°)

Schaftlänge Length of shaft Longitud del vástago Lunghezza dell' asta	Bissbreite / Width of bite / Anchura de la boca / Larghezza del morso			
	2 mm	3 mm	4 mm	5 mm
180 mm	026-670-002	026-670-003	026-670-004	026-670-005

- ein Teil
- einfach zu demontieren
- einfach zu reinigen
- einfach zusammenzufügen

Demontage Disassembly

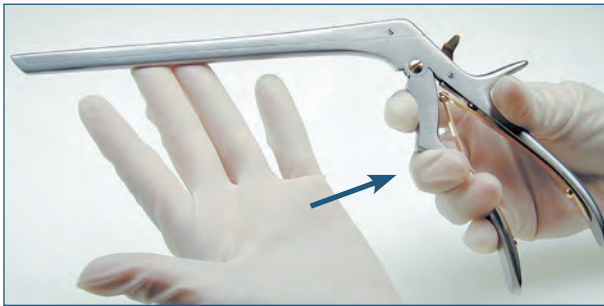

Zuerst den Griff schließen ...
First close the handle ...



dann den Riegel nach unten drücken ...
than push the lever downwards ...

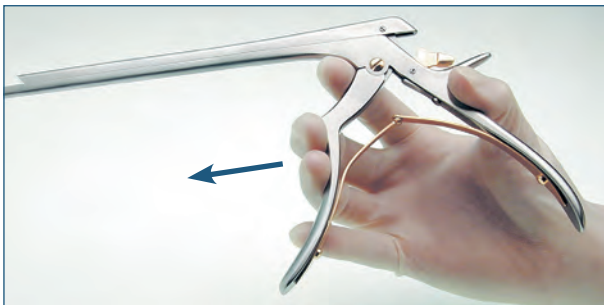

nun den Griff wieder öffnen ...
now open the handle ...



und hinten auf den Schaft drücken.
and push downwards at the end of shaft.



026

Laminektomie-Stanzen
Laminectomy Punches
Pinzas cortantes para laminectomia
Pinze per laminectomia

zerlegbar
detachable
desmontable
smontabile

- one piece
- easy to disassemble
- easy to clean
- easy to assemble

Zusammenfügen Assembly



Zuerst Schaftteile ineinandersetzen ...
First push shaft parts into one other ...

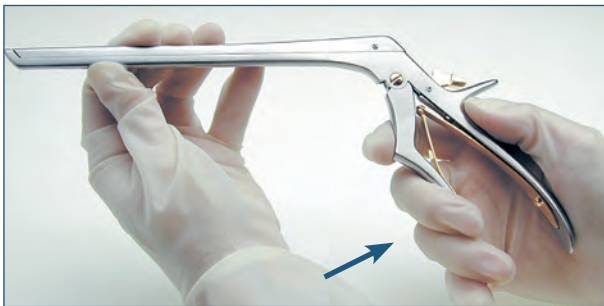

dann den Griff schließen ...
than close the handle ...

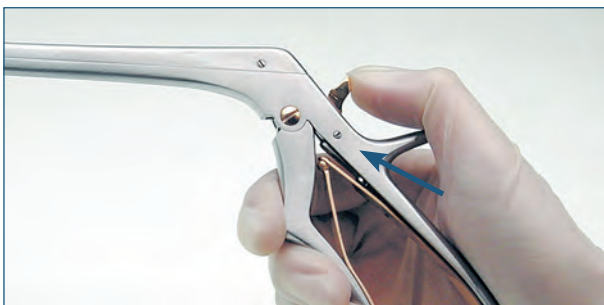

nun den Riegel nach oben drücken ...
now push the lever upwards ...

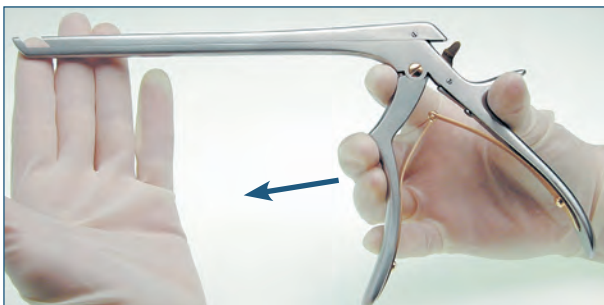

und den Griff wieder öffnen.
and finally open the handle.

Laminektomie-Stanzen zerlegbar
 Laminectomy Punches detachable
 Pinzas cortantes para laminectomia desmontable
 Pinze per laminectomia smontabile



026

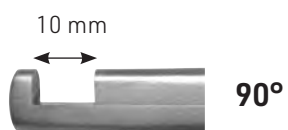
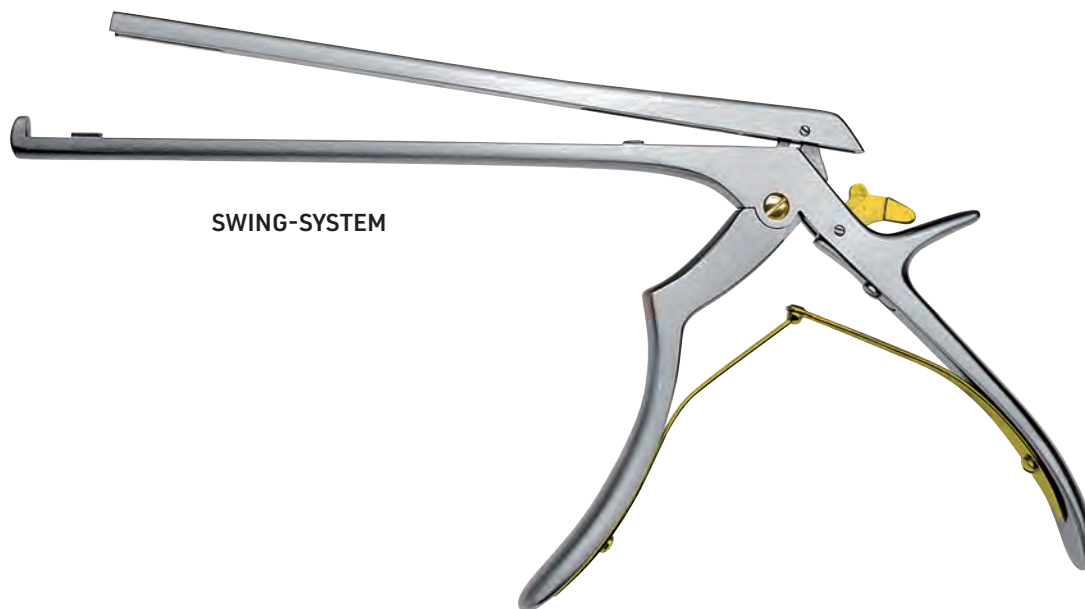

Schaftlänge Length of shaft Longitud del vástago Lunghezza dell' asta	Bissbreite / Width of bite / Anchura de la boca / Larghezza del morso					
		2 mm	3 mm	4 mm	5 mm	6 mm
180 mm		026-700-002	026-700-003	026-700-004	026-700-005	026-700-006
200 mm		026-702-002	026-702-003	026-702-004	026-702-005	026-702-006
230 mm		026-704-002	026-704-003	026-704-004	026-704-005	026-704-006



026

Laminektomie-Stanzen zerlegbar
 Laminectomy Punches detachable
 Pinzas cortantes para laminectomia desmontable
 Pinze per laminectomia smontabile

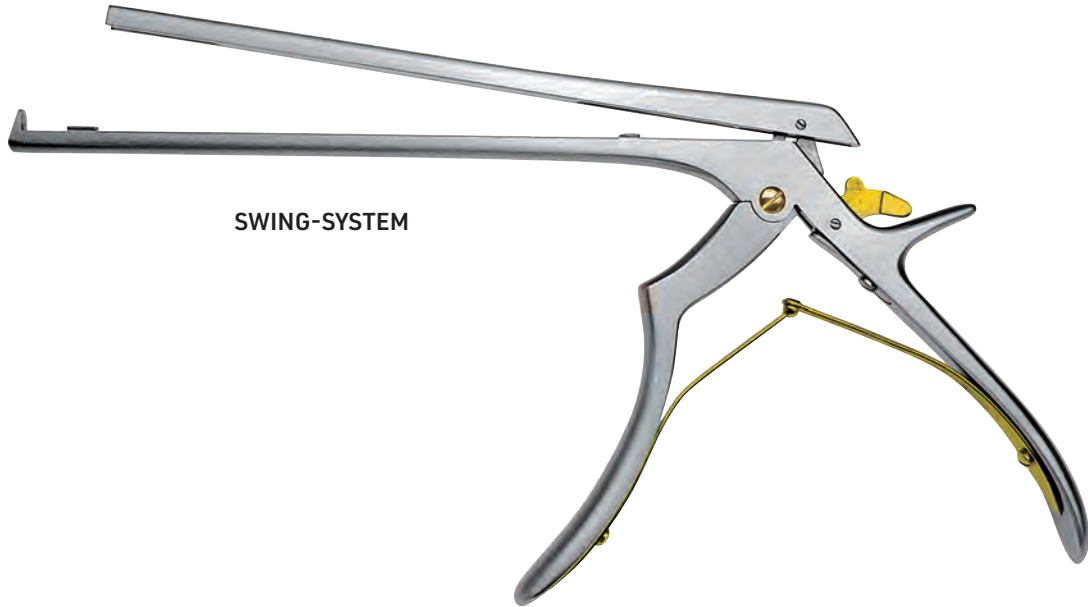

SWING-SYSTEM

KERRISON

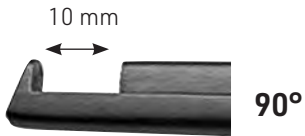

Dünnpfuß (Mikro)
 Thin footplate (Micro)
 Lámina de punzonar estrecha (Micro)
 Battente sottile

Schaftlänge Length of shaft Longitud del vástago Lunghezza dell' asta	Bissbreite / Width of bite / Anchura de la boca / Larghezza del morso				
	2 mm	3 mm	4 mm	5 mm	6 mm
180 mm	026-710-002	026-710-003	026-710-004	026-710-005	026-710-006
200 mm	026-712-002	026-712-003	026-712-004	026-712-005	026-712-006
230 mm	026-714-002	026-714-003	026-714-004	026-714-005	026-714-006

Laminektomie-Stanzen zerlegbar
 Laminectomy Punches detachable
 Pinzas cortantes para laminectomia desmontable
 Pinze per laminectomia smontabile



026

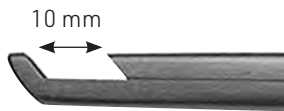
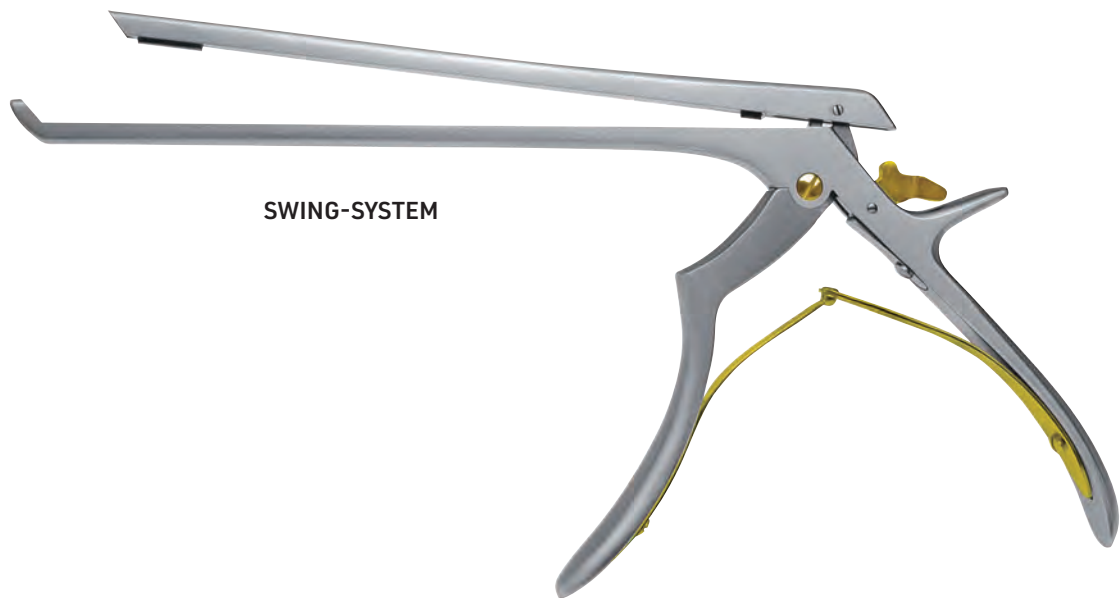

130° (40°)

KERRISON

Schaftlänge Length of shaft Longitud del vástago Lunghezza dell`asta	Bissbreite / Width of bite / Anchura de la boca / Larghezza del morso					
	2 mm	3 mm	4 mm	5 mm	6 mm	
180 mm	026-720-002	026-720-003	026-720-004	026-720-005	026-720-006	
200 mm	026-722-002	026-722-003	026-722-004	026-722-005	026-722-006	
230 mm	026-724-002	026-724-003	026-724-004	026-724-005	026-724-006	

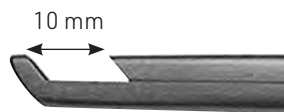

130° (40°)

mit Auswerfer
with ejector
con espulsor
con espulsore

Schaftlänge Length of shaft Longitud del vástago Lunghezza dell`asta	Bissbreite / Width of bite / Anchura de la boca / Larghezza del morso			
	3 mm	4 mm	5 mm	6 mm
180 mm	026-730-003	026-730-004	026-730-005	026-730-006
200 mm	026-732-003	026-732-004	026-732-005	026-732-006
230 mm	026-734-003	026-734-004	026-734-005	026-734-006



026

Laminektomie-Stanzen zerlegbar
 Laminectomy Punches detachable
 Pinzas cortantes para laminectomia desmontable
 Pinze er laminectomiasmontabile

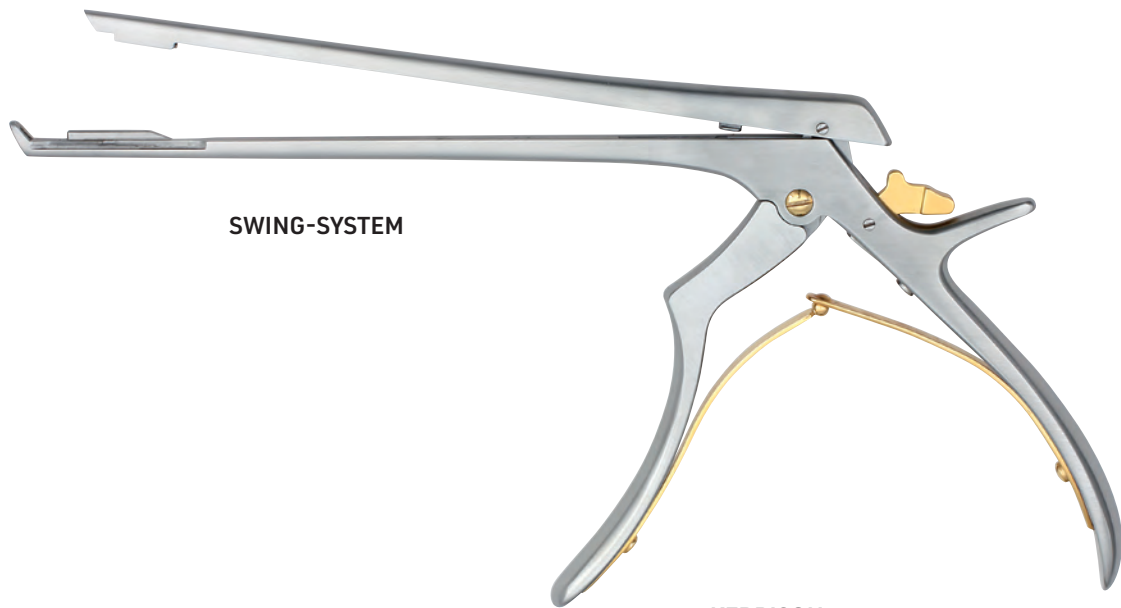

KERRISON

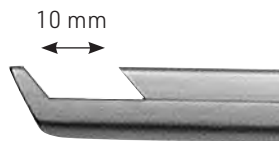

130° (40°)

Dünnpfuß (Mikro)
 Thin footplate (Micro)
 Lámina de punzonar estrecha (Micro)
 Battente sottile

Schaftlänge Length of shaft Longitud del vástago Lunghezza dell' asta	Bissbreite / Width of bite / Anchura de la boca / Larghezza del morso				
	2 mm	3 mm	4 mm	5 mm	6 mm
180 mm	026-740-002	026-740-003	026-740-004	026-740-005	026-740-006
200 mm	026-742-002	026-742-003	026-742-004	026-742-005	026-742-006
230 mm	026-744-002	026-744-003	026-744-004	026-744-005	026-744-006

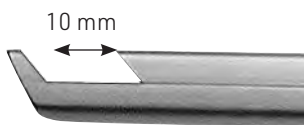

130° (40°)

Dünnpfuß (Mikro)
 Thin footplate (Micro)
 Lámina de punzonar estrecha (Micro)
 Battente sottile

mit Auswerfer
 with ejector
 con espulsor
 con espulsore

Schaftlänge Length of shaft Longitud del vástago Lunghezza dell' asta	Bissbreite / Width of bite / Anchura de la boca / Larghezza del morso			
	3 mm	4 mm	5 mm	6 mm
180 mm	026-750-003	026-750-004	026-750-005	026-750-006
200 mm	026-752-003	026-752-004	026-752-005	026-752-006
230 mm	026-754-003	026-754-004	026-754-005	026-754-006

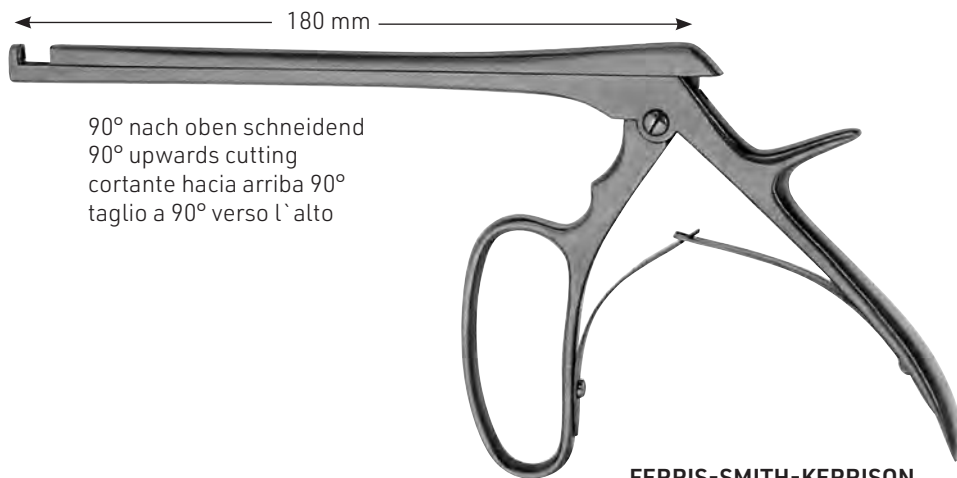

90° nach oben schneidend
 90° upwards cutting
 cortante hacia arriba 90°
 taglio a 90° verso l'alto

FERRIS-SMITH-KERRISON

- | | | |
|--------------------|--------|--|
| 026-790-003 | 3,0 mm | |
| 026-790-005 | 5,0 mm | |

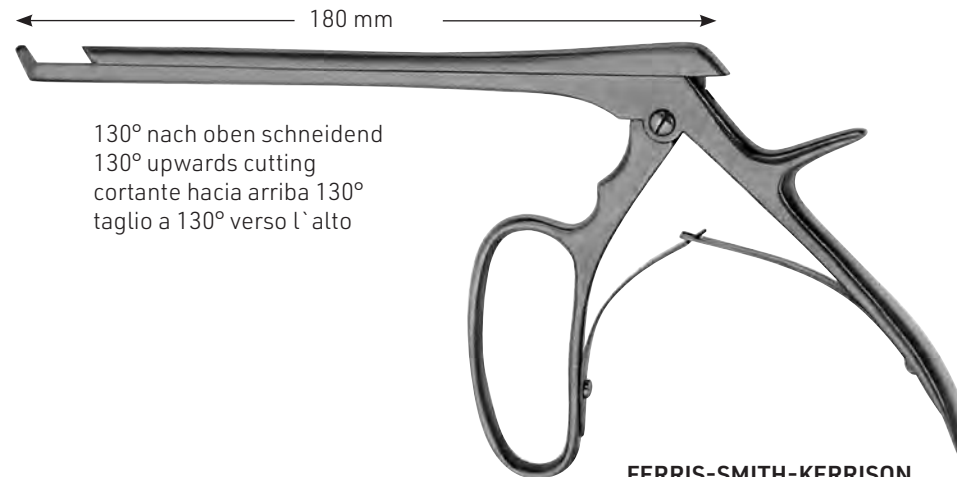

130° nach oben schneidend
 130° upwards cutting
 cortante hacia arriba 130°
 taglio a 130° verso l'alto

FERRIS-SMITH-KERRISON

- | | | | |
|--------------------|--------------------|--------|--|
| a = 180 mm | a = 200 mm | | |
| 026-792-003 | 026-794-003 | 3,0 mm | |
| 026-792-005 | 026-794-005 | 5,0 mm | |

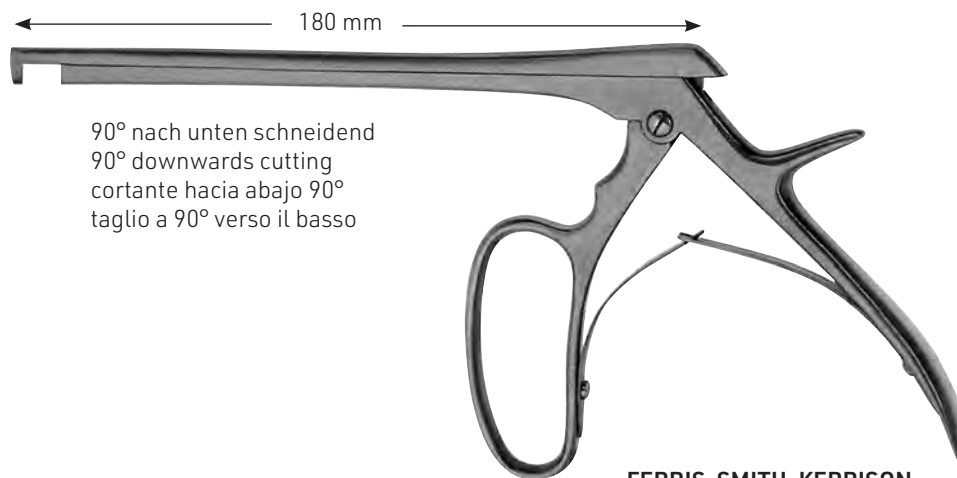

90° nach unten schneidend
 90° downwards cutting
 cortante hacia abajo 90°
 taglio a 90° verso il basso

FERRIS-SMITH-KERRISON

- | | | |
|--------------------|--------|--|
| 026-796-003 | 3,0 mm | |
| 026-796-005 | 5,0 mm | |



026

Laminektomie-Zangen
Laminectomy Rongeurs
Pinzas cortantes para laminectomia
Pinze per laminectomia

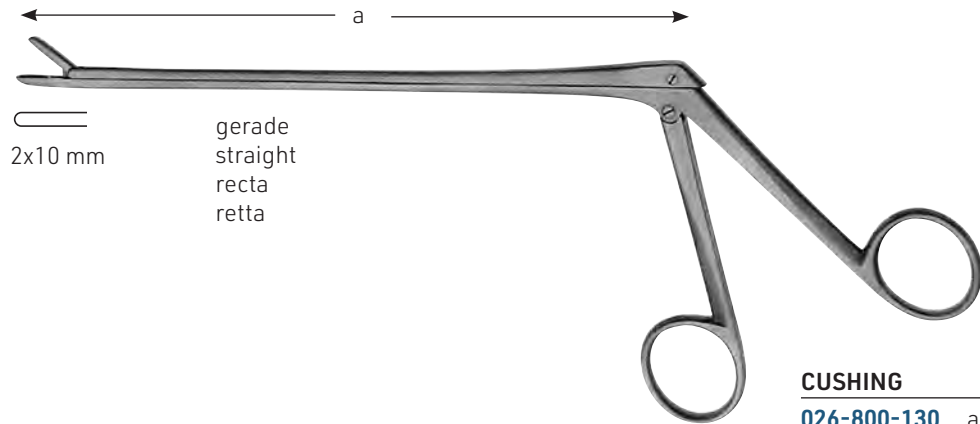

2x10 mm
gerade
straight
recta
retta

CUSHING

026-800-130 a = 130 mm
026-800-150 a = 150 mm
026-800-180 a = 180 mm

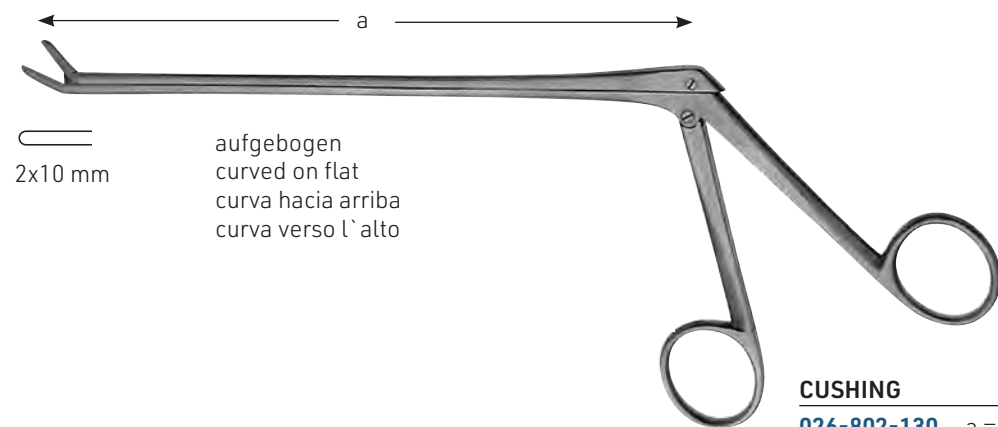

2x10 mm
aufgebogen
curved on flat
curva hacia arriba
curva verso l'alto

CUSHING

026-802-130 a = 130 mm
026-802-150 a = 150 mm
026-802-180 a = 180 mm

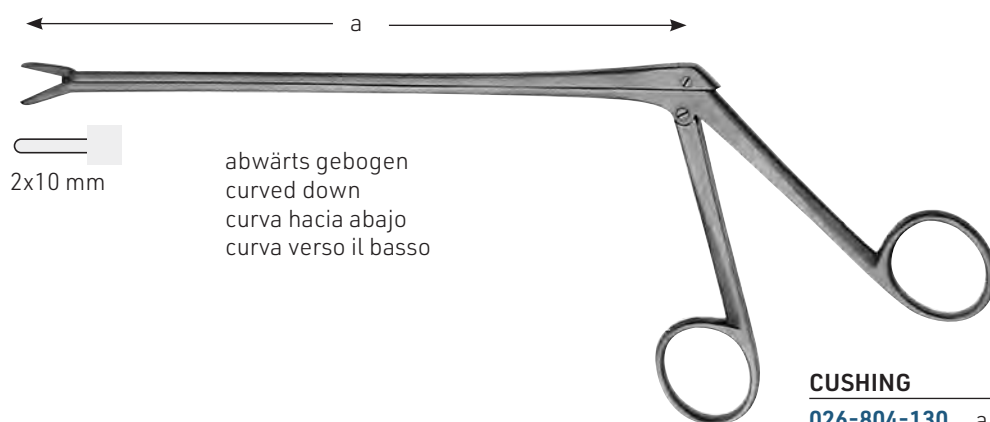

2x10 mm
abwärts gebogen
curved down
curva hacia abajo
curva verso il basso

CUSHING

026-804-130 a = 130 mm
026-804-150 a = 150 mm
026-804-180 a = 180 mm

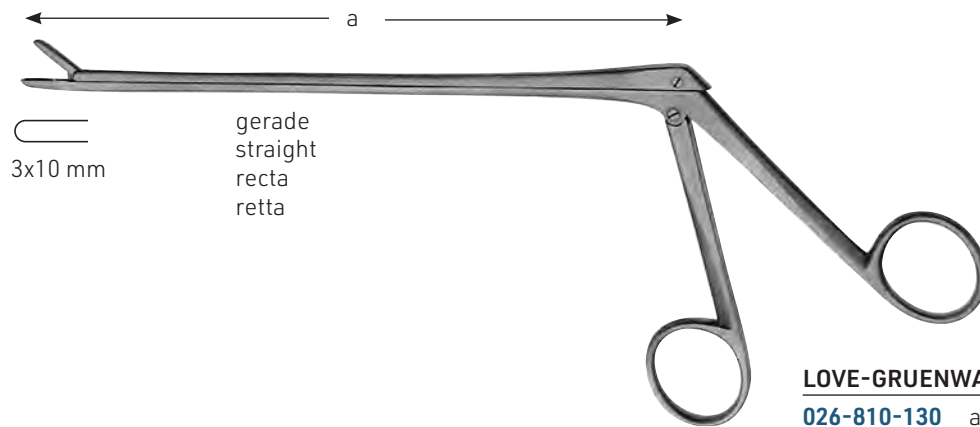

3x10 mm
 gerade
 straight
 recta
 retta

LOVE-GRUENWALD

- 026-810-130** a = 130 mm
- 026-810-150** a = 150 mm
- 026-810-180** a = 180 mm

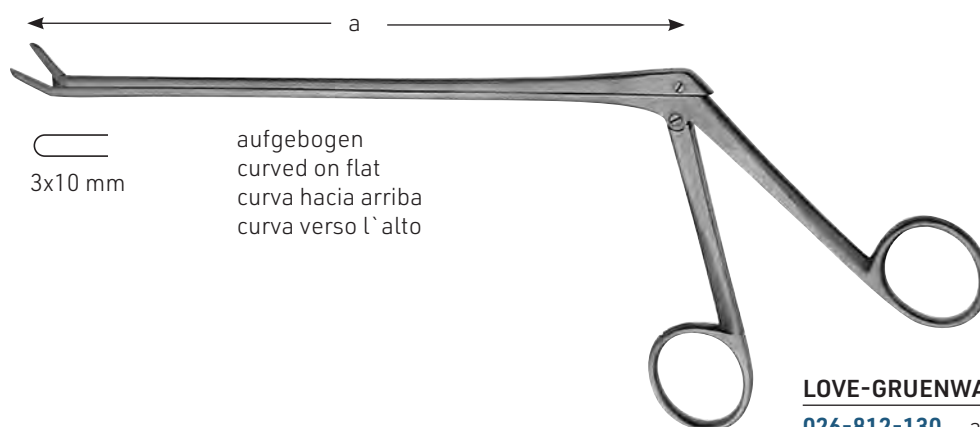

3x10 mm
 aufgebogen
 curved on flat
 curva hacia arriba
 curva verso l'alto

LOVE-GRUENWALD

- 026-812-130** a = 130 mm
- 026-812-150** a = 150 mm
- 026-812-180** a = 180 mm

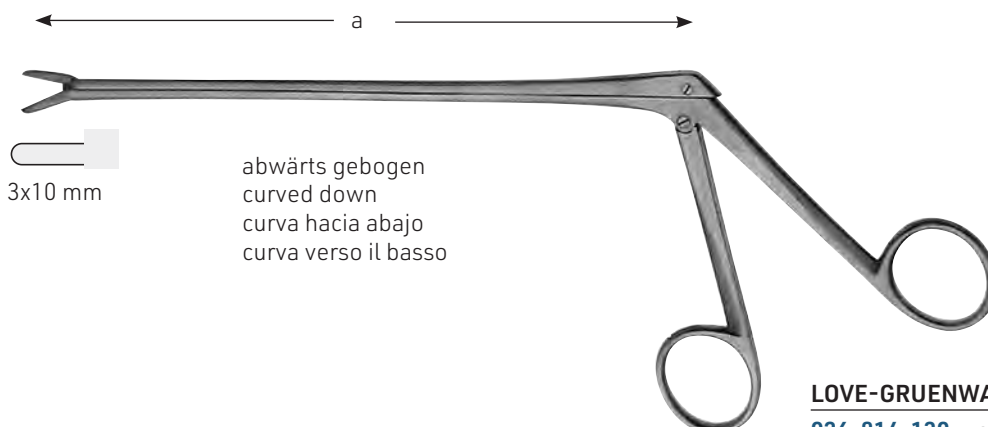

3x10 mm
 abwärts gebogen
 curved down
 curva hacia abajo
 curva verso il basso

LOVE-GRUENWALD

- 026-814-130** a = 130 mm
- 026-814-150** a = 150 mm
- 026-814-180** a = 180 mm



026

Laminektomie-Zangen
Laminectomy Rongeurs
Pinzas cortantes para laminectomia
Pinze per laminectomia

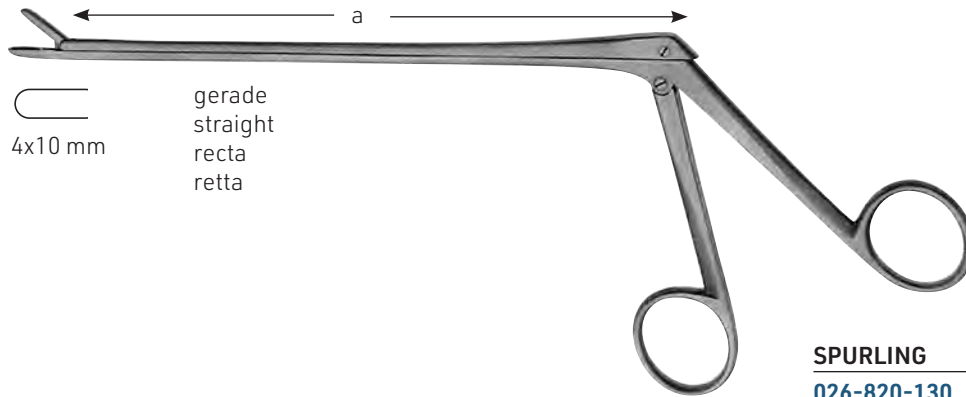

4x10 mm

gerade
straight
recta
retta

SPURLING

026-820-130 a = 130 mm
026-820-150 a = 150 mm
026-820-180 a = 180 mm

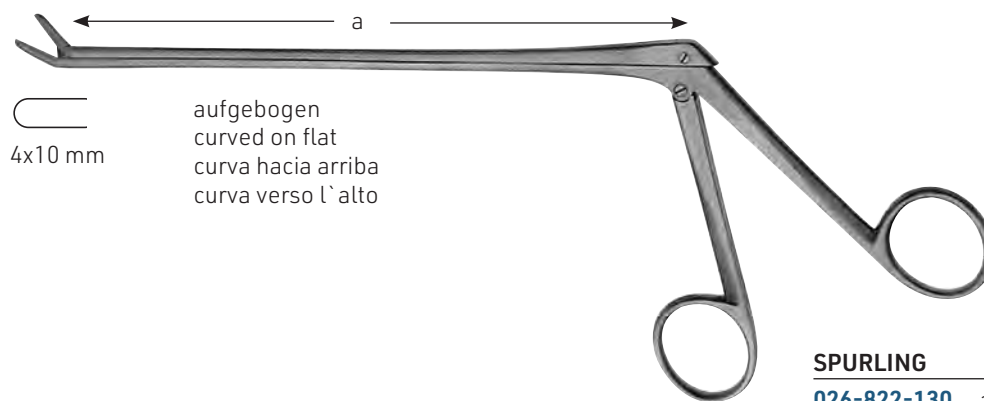

4x10 mm

aufgebogen
curved on flat
curva hacia arriba
curva verso l'alto

SPURLING

026-822-130 a = 130 mm
026-822-150 a = 150 mm
026-822-180 a = 180 mm



4x10 mm

abwärts gebogen
curved down
curva hacia abajo
curva verso il basso

SPURLING

026-824-130 a = 130 mm
026-824-150 a = 150 mm
026-824-180 a = 180 mm

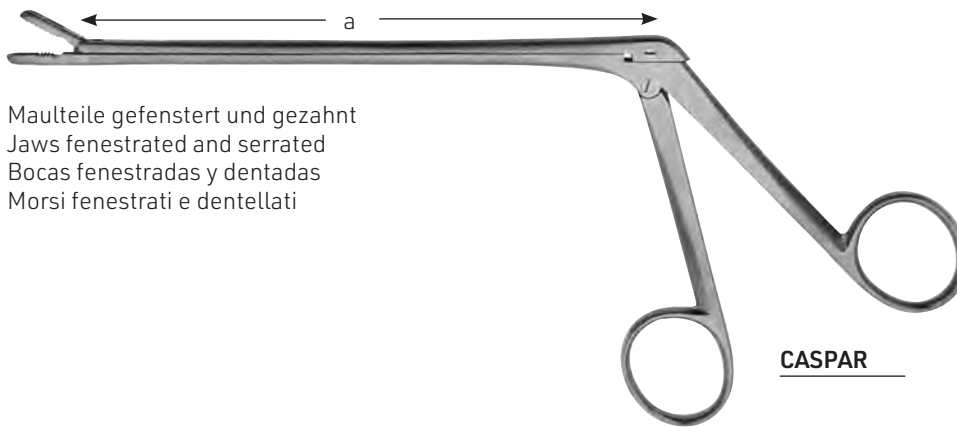

Maulteile gefenstert und gezahnt
 Jaws fenestrated and serrated
 Bocas fenestradas y dentadas
 Morsi fenestrati e dentellati

Schaftlänge Length of shaft Longitud del vástago Lunghezza dell' asta	Bissbreite / Width of bite / Anchura de la boca / Larghezza del morso				
	2,0 x 12,0 mm	3,0 x 12,0 mm	4,0 x 14,0 mm	5,0 x 14,0 mm	6,0 x 16,0 mm
a = 140 mm	026-830-140	026-832-140	026-834-140	026-836-140	026-838-140
a = 160 mm	026-830-160	026-832-160	026-834-160	026-836-160	026-838-160
a = 185 mm	026-830-185	026-832-185	026-834-185	026-836-185	026-838-185

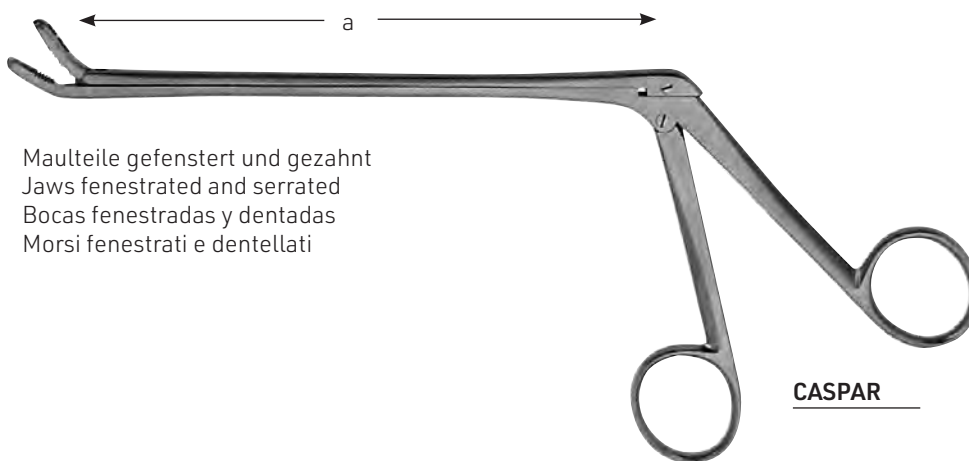

Maulteile gefenstert und gezahnt
 Jaws fenestrated and serrated
 Bocas fenestradas y dentadas
 Morsi fenestrati e dentellati

Schaftlänge Length of shaft Longitud del vástago Lunghezza dell' asta	Bissbreite / Width of bite / Anchura de la boca / Larghezza del morso		
	3,0 x 12,0 mm	4,0 x 14,0 mm	5,0 x 14,0 mm
a = 140 mm	026-842-140	026-844-140	026-846-140
a = 160 mm	026-842-160	026-844-160	026-846-160
a = 185 mm	026-842-185	026-844-185	026-846-185







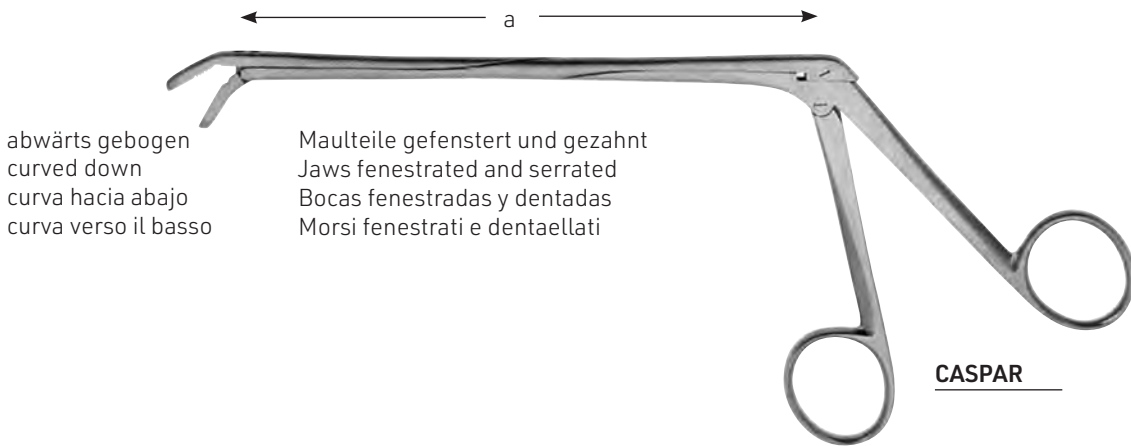

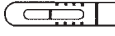
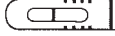

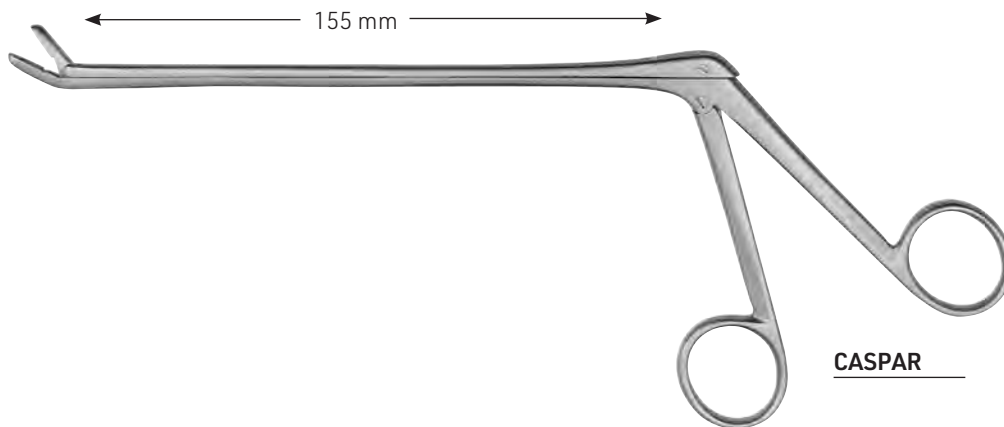
026

Laminektomie-Zangen
Laminectomy Rongeurs
Pinzas cortantes para laminectomia
Pinze per laminectomia



Schaftlänge Length of shaft Longitud del vástago Lunghezza dell' asta	Bissbreite / Width of bite / Anchura de la boca / Larghezza del morso	
		
	3,0 x 12,0 mm	4,0 x 14,0 mm
a = 140 mm	026-852-140	026-854-140
a = 160 mm	026-852-160	026-854-160
a = 185 mm	026-852-185	026-854-185



	Bissbreite / Width of bite / Anchura de la boca / Larghezza del morso			
				
	026-860-002	026-860-003	026-860-004	026-860-005
	026-862-002	026-862-003	026-862-004	026-862-005
	026-864-002	026-864-003	026-864-004	026-864-005

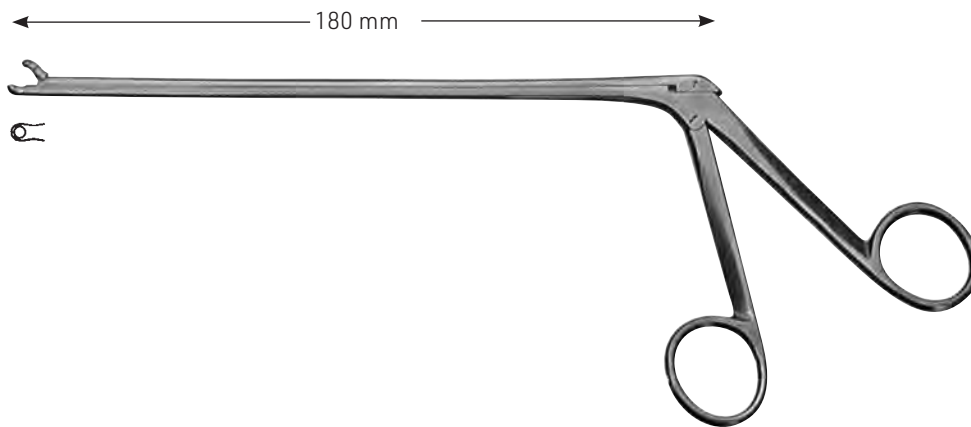

YASARGIL

026-870-180 Ø 2,0 mm

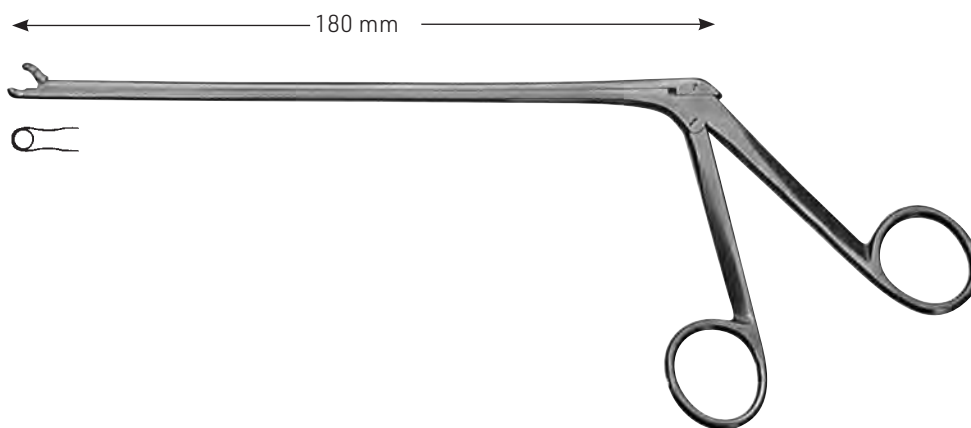

OLDBERG

026-872-180 Ø 3,5 mm

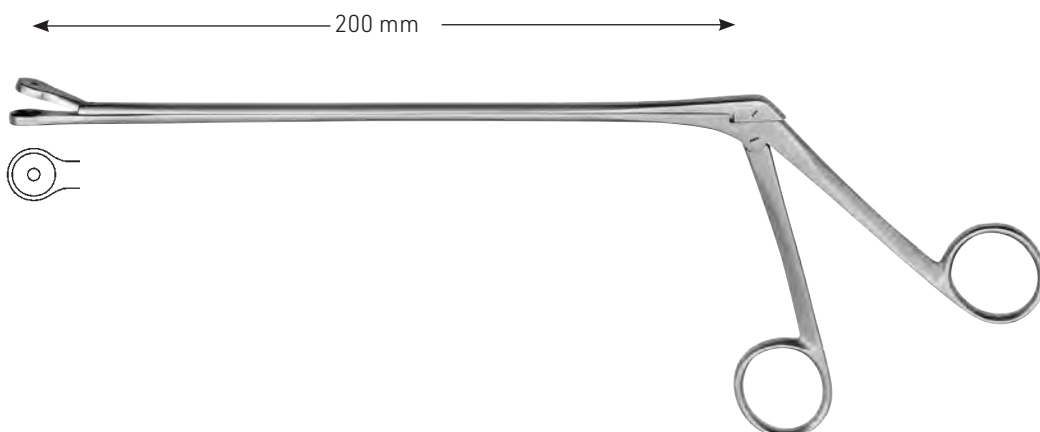

LANDOLT





026-874-200 Ø 9,0 mm

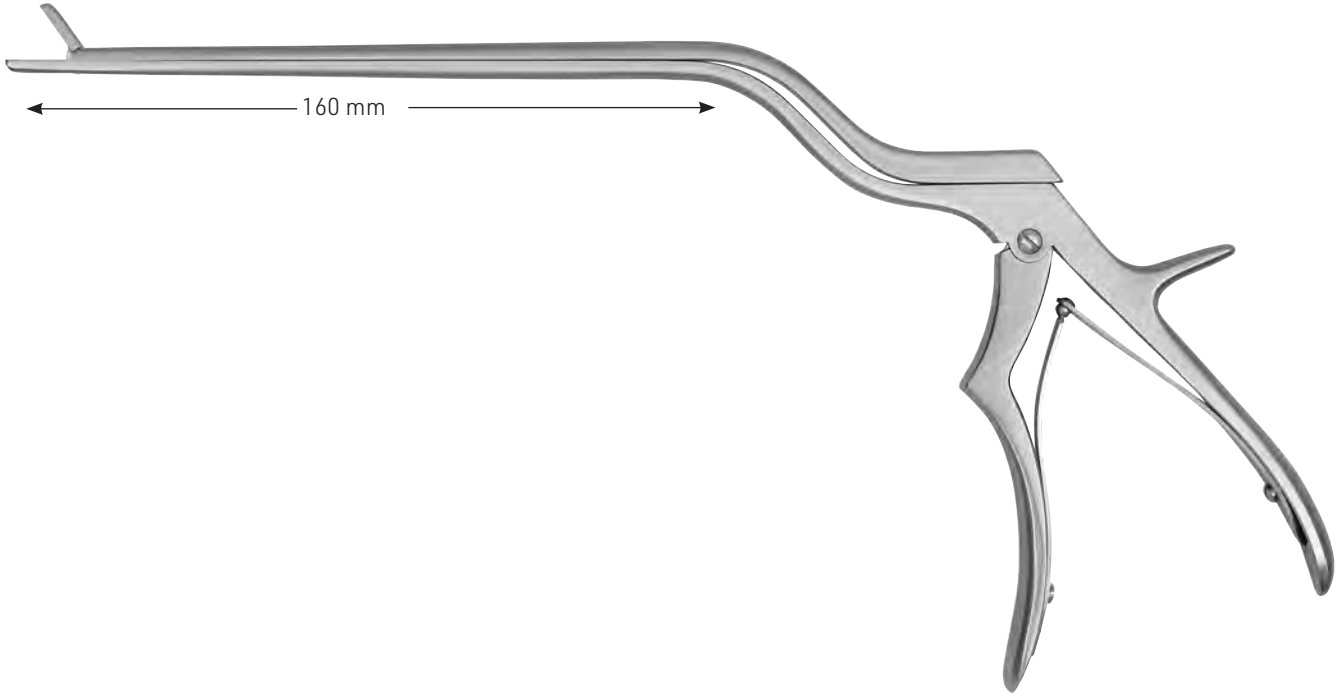

026

Laminektomie-Zangen
Laminectomy Rongeurs
Pinzas cortantes para laminectomía
Pinze per laminectomia



	Bissbreite / Width of bite / Anchura de la boca / Larghezza del morso		
			
	2,0 x 8,0 mm	3,0 x 9,0mm	4,0 x 10,0 mm
	026-880-002	026-880-003	026-880-004
	026-882-002	026-882-003	026-882-004

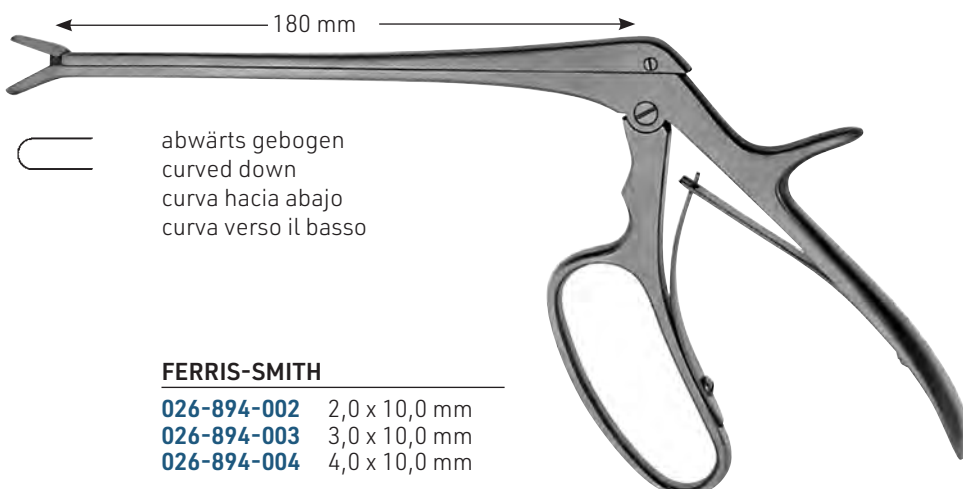
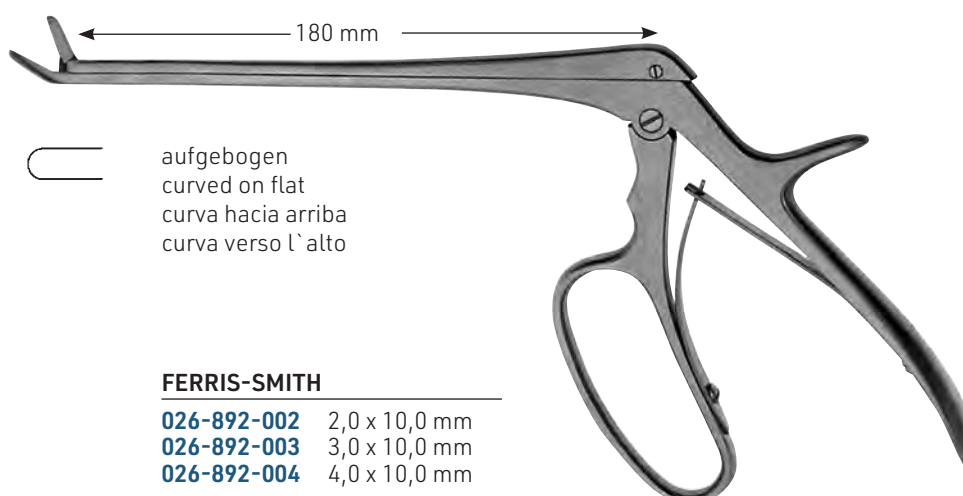
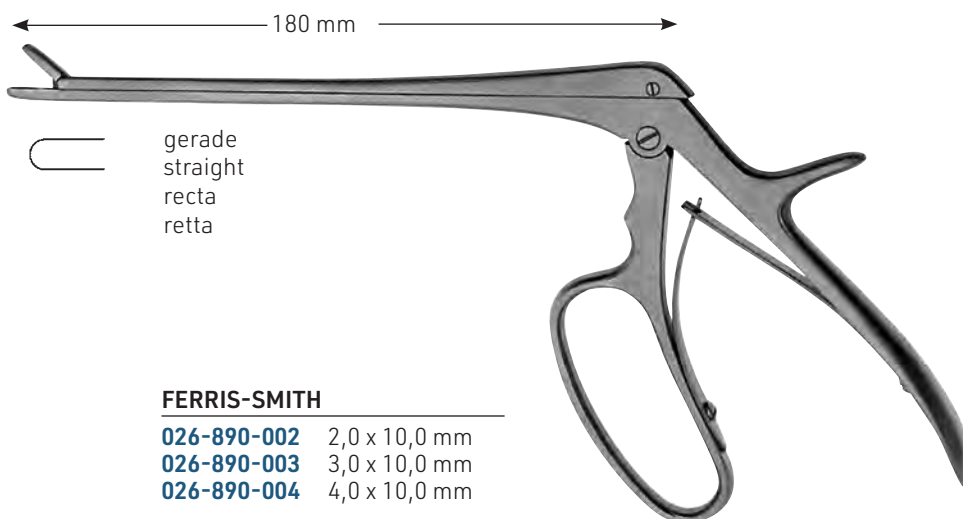



026

Mikro-Zangen für Neurochirurgie
 Micro Forceps for Neurosurgery
 Micro Pinzas para Neurocirugía
 Micro Pinze per Neurochirurgia

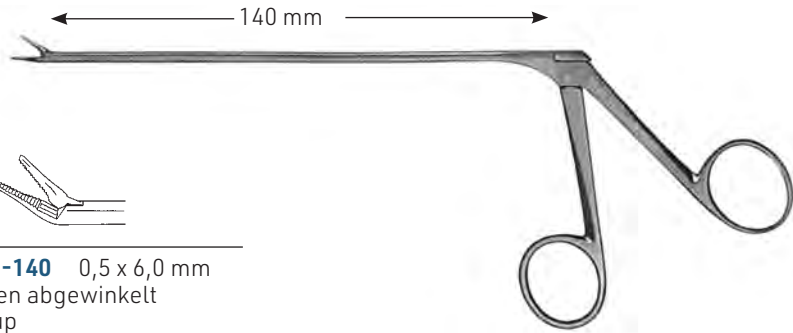

026-900-140 0,5 x 6,0 mm
 gerade
 straight
 recta
 retta

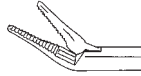

026-901-140 0,5 x 6,0 mm
 nach oben abgewinkelt
 angled up
 angulada hacia arriba
 angolata in alto



026-903-140 0,5 x 6,0 mm
 nach rechts gebogen
 curved to right
 curva a la derecha
 curve a destra



026-905-140 0,5 x 6,0 mm
 nach links gebogen
 curved to left
 curva a la izquierda
 curve a sinistra

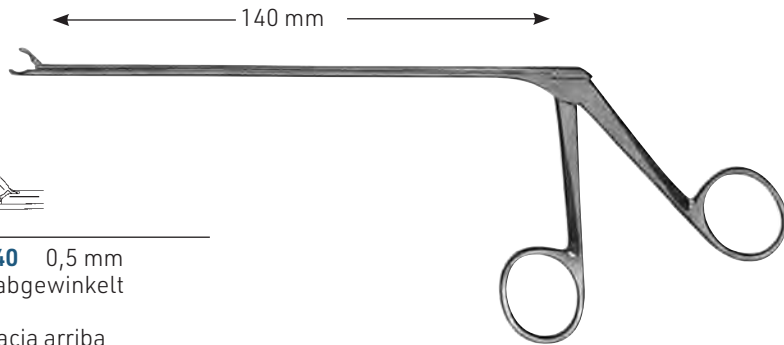

026-910-140 0,5 mm
026-920-140 1,0 mm
 gerade
 straight
 recta
 retta



026-911-140 0,5 mm
 nach oben abgewinkelt
 angled up
 angulada hacia arriba
 angolata in alto





026-913-140 0,5 mm
026-923-140 1,0 mm
 nach rechts gebogen
 curved to right
 curva a la derecha
 curve a destra

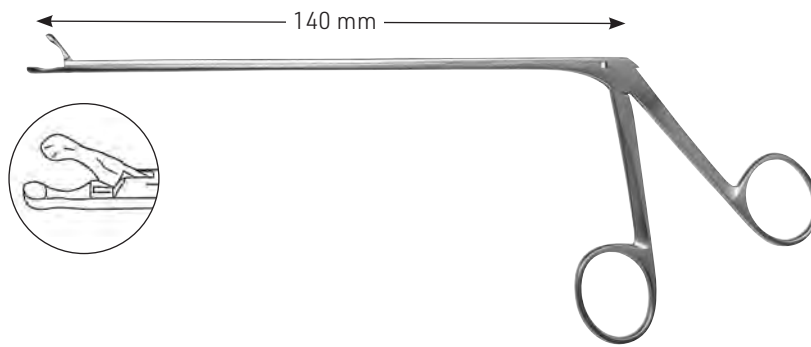

026-915-140 0,5 mm
026-925-140 1,0 mm
 nach links gebogen
 curved to left
 curva a la izquierda
 curve a sinistra



026-930-140	Ø 2,0 mm	
026-932-140	Ø 3,0 mm	

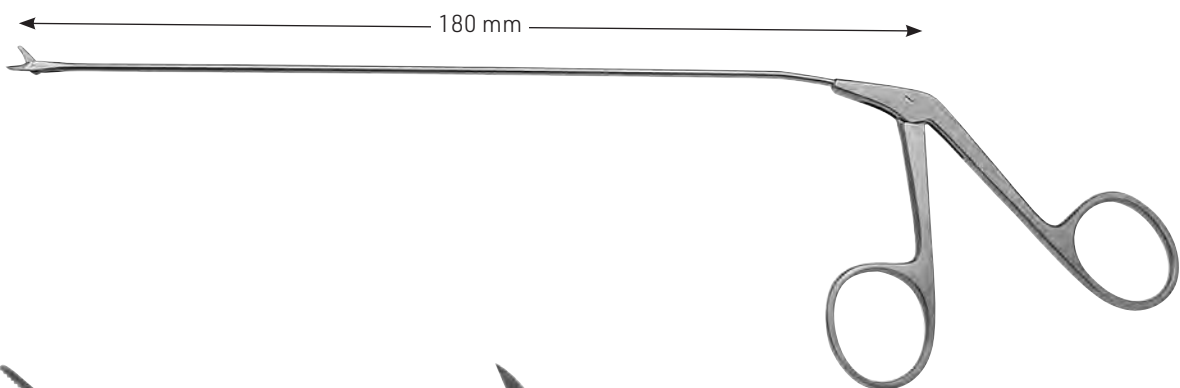

YASARGIL
026-940-180 Ø 2,0 mm



NICOLA
026-942-180 Ø 2,0 mm



NICOLA
026-944-180 Ø 2,0 mm



026

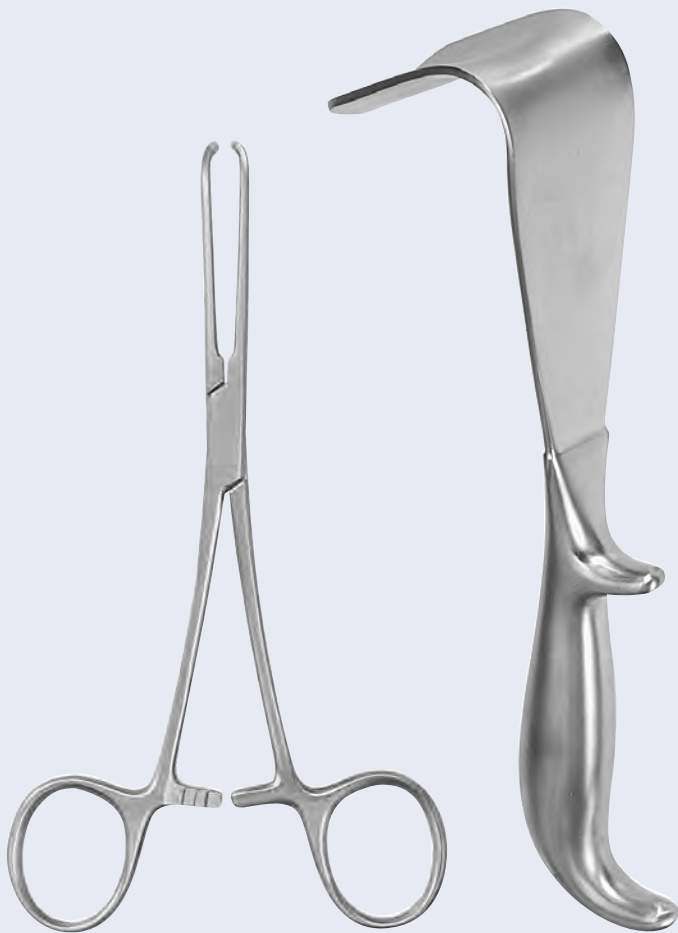

027

Magen, Darm, Urologie
Stomach, Intestines, Urology
Estómago, Intestinos,
Urología
Stomaco, Intestini, Urologia



ALLIS-BABY

- 027-100-120** 12,0 cm / 4³/₄"
- 027-100-140** 14,0 cm / 5¹/₂"



ALLIS

- 027-110-150** 15,0 cm / 6"
- 027-110-190** 19,0 cm / 7¹/₂"



ALLIS

- 027-120-150** 15,0 cm / 6"
- 027-120-190** 19,0 cm / 7¹/₂"
- 027-120-220** 22,0 cm / 8³/₄"
- 027-120-250** 25,0 cm / 9³/₄"

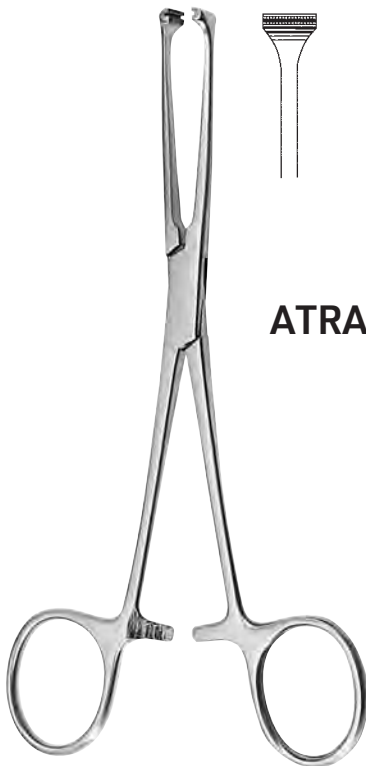

ALLIS

- 027-122-160** 16,0 cm / 6¹/₄"
- 027-122-200** 20,0 cm / 8"
- 027-122-250** 25,0 cm / 9³/₄"
- 027-122-300** 30,0 cm / 11¹/₄"

ATRAUMA



ALLIS-ADAIR

- 027-130-155** 15,5 cm / 6"



BOYS-ALLIS

027-132-150 15,0 cm / 6"



JUDD-ALLIS

027-134-150 15,0 cm / 6"
027-134-190 19,0 cm / 7 1/2"



THOMS-ALLIS

027-140-200 20,0 cm / 8"



ALLIS

027-142-200 20,0 cm / 8"

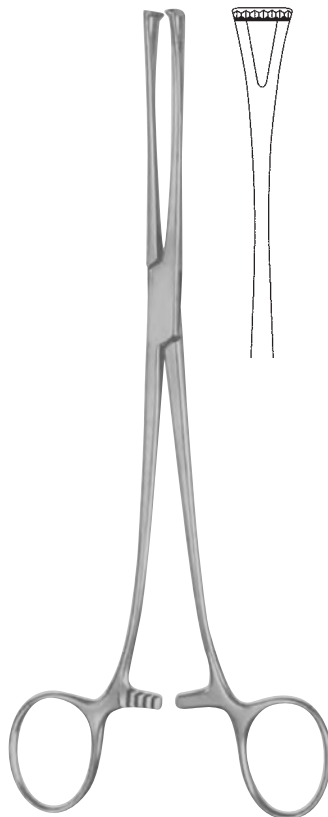

LOCKWOOD-ALLIS

027-144-200 20,0 cm / 8"

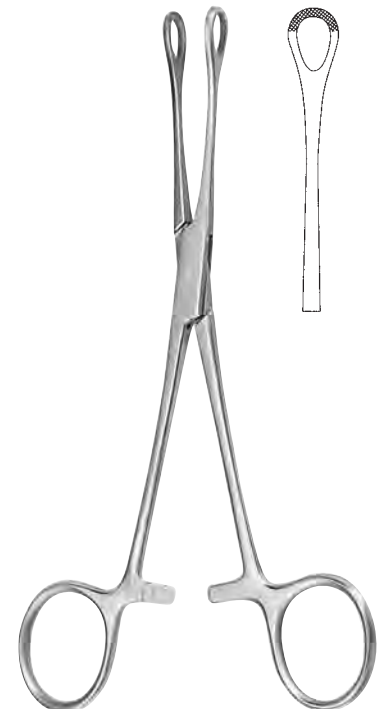

WILLIAMS

027-146-160 16,0 cm / 6 1/4"



027

Darm- und Gewebefasszangen
 Intestinal and Tissue Grasping Forceps
 Pinzas intestinales y para tejidos
 Pinze da presa per intestino e tessuti



LITTLEWOOD

027-152-185 18,5 cm / 7 1/4"

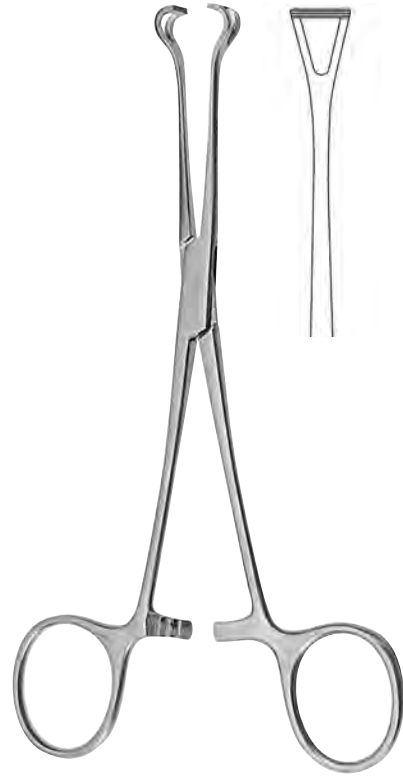

BABCOCK

027-160-140 14,0 cm / 5 1/2"
027-160-160 16,0 cm / 8"
027-160-180 18,0 cm / 7"
027-160-200 20,0 cm / 8"
027-160-240 24,0 cm / 9 1/2"

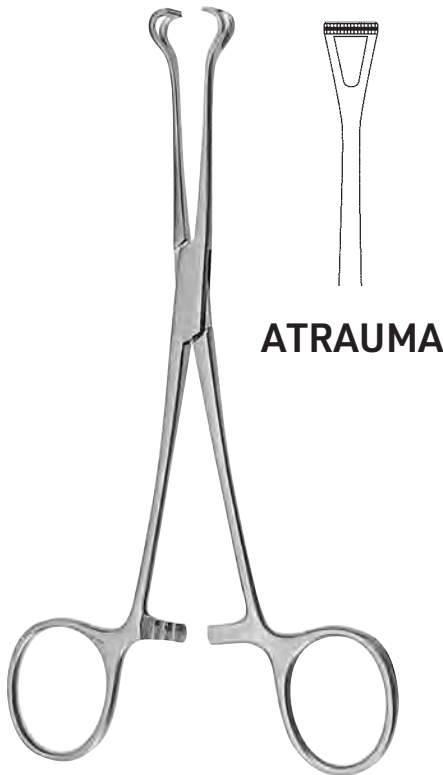

ATRAUMA

BABCOCK

027-162-160 16,0 cm / 6 1/4"
027-162-200 20,0 cm / 8"



BABCOCK-TC

027-164-160 16,0 cm / 6 1/4"
027-164-200 20,0 cm / 8"



DUVAL

027-170-180 18,0 cm / 7"
027-170-200 20,0 cm / 8"

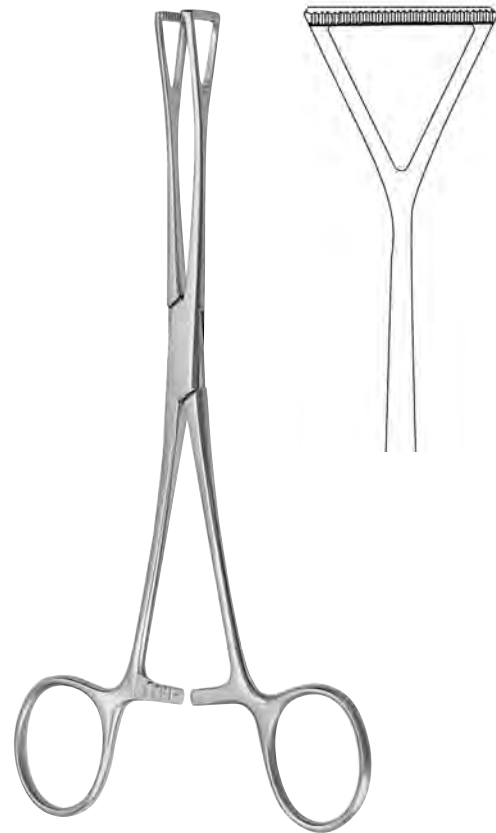

DUVAL

027-172-200 20,0 cm / 8"
027-172-230 23,0 cm / 9"



DUVAL-TC

027-174-200 20,0 cm / 8"

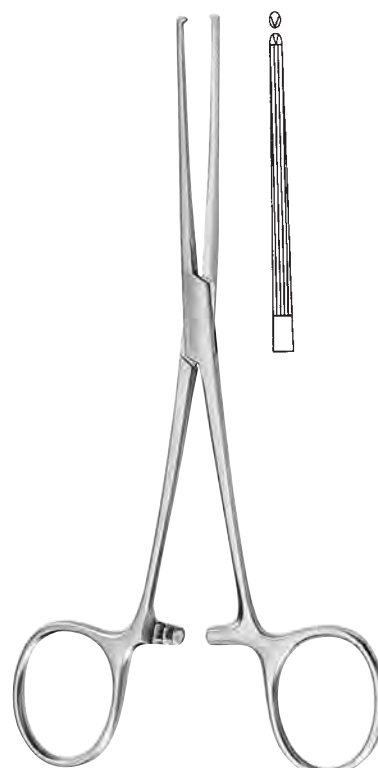

ALLEN

027-200-155 15,5 cm / 6"



027

Darm- und Gewebefasszangen
Intestinal and Tissue Grasping Forceps
Pinzas intestinales y para tejidos
Pinze da presa per intestino e tessuti



027-210-180

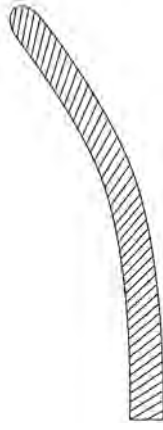

027-211-180

BABY-DOYEN

027-210-180 - 027-211-180

18,0 cm / 7"



027-214-210
027-214-230

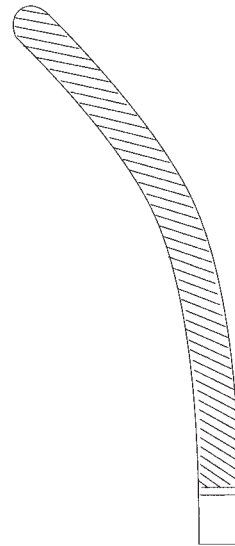

027-215-210
027-215-230

DOYEN

027-214-210 - 027-215-210
027-214-230 - 027-215-230

21,0 cm / 8¹/₄"
23,0 cm / 9"



027-220-210
027-220-230
027-220-250

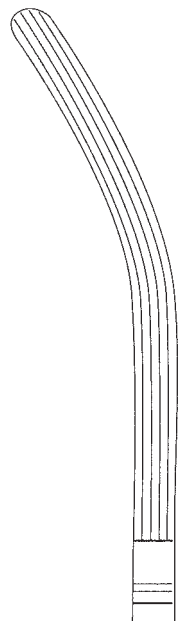

027-221-210
027-221-230
027-221-250

MAYO-ROBSON

027-220-210 - 027-221-210	21,0 cm / 8 ¹ / ₄ "
027-220-230 - 027-221-230	23,0 cm / 9"
027-220-250 - 027-221-250	25,0 cm / 9 ³ / ₄ "



027-230-220
027-230-250
027-230-280

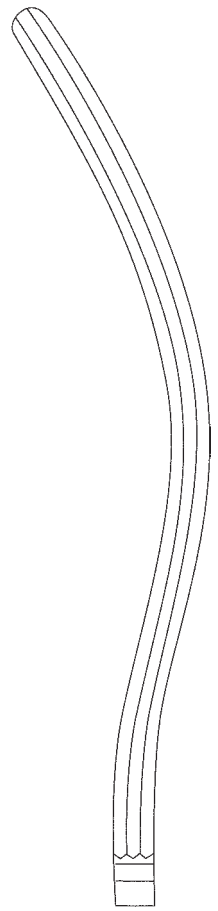
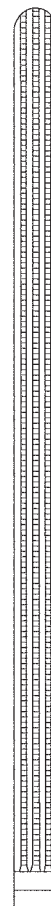

027-231-220
027-231-250
027-231-280

KOCHER

027-230-220 - 027-231-220	22,0 cm / 8 ³ / ₄ "
027-230-250 - 027-231-250	25,0 cm / 9 ³ / ₄ "
027-230-280 - 027-231-280	28,0 cm / 11"



027

Klemmen
Clamps
Pinzas
Pinze



027-232-330

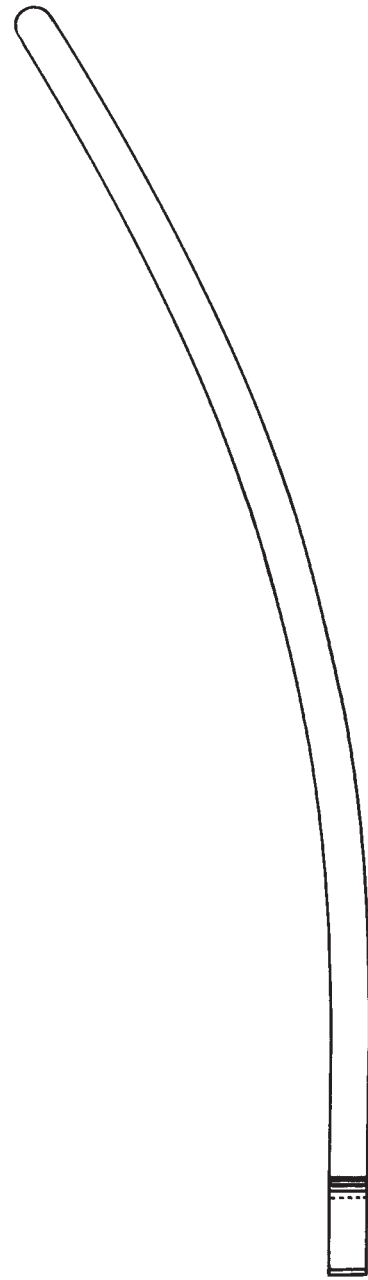

027-233-330

SCUDDER

027-232-330 - 027-233-330

33,0 cm / 13"

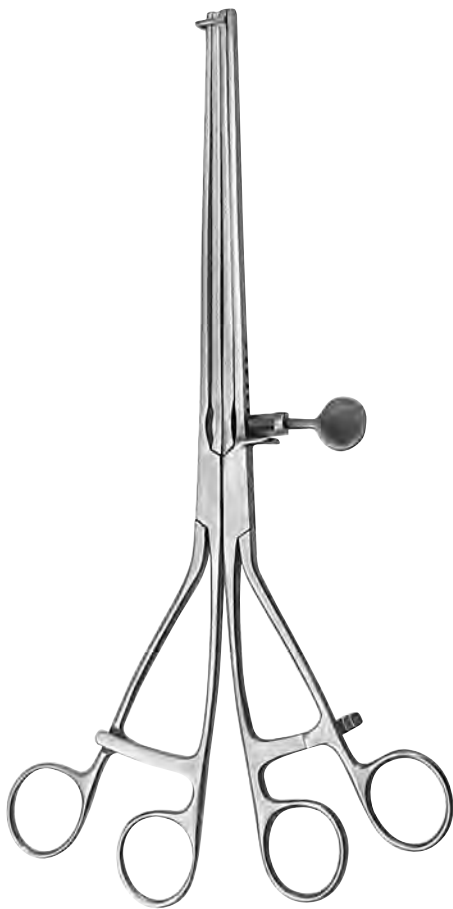

027-234-300

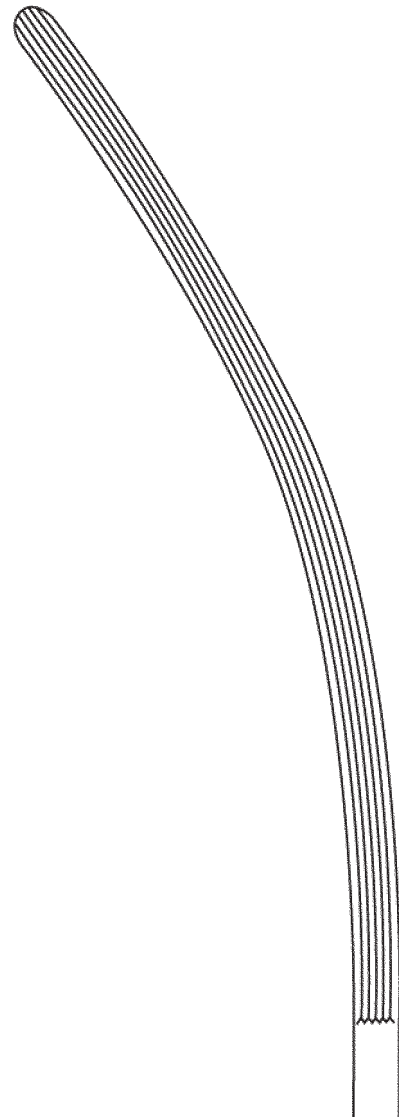

027-235-300

LANE

027-234-300 - 027-235-300

30,0 cm / 11³/₄"



027

Klemmen
Clamps
Pinzas
Pinze



027-236-250
027-236-300

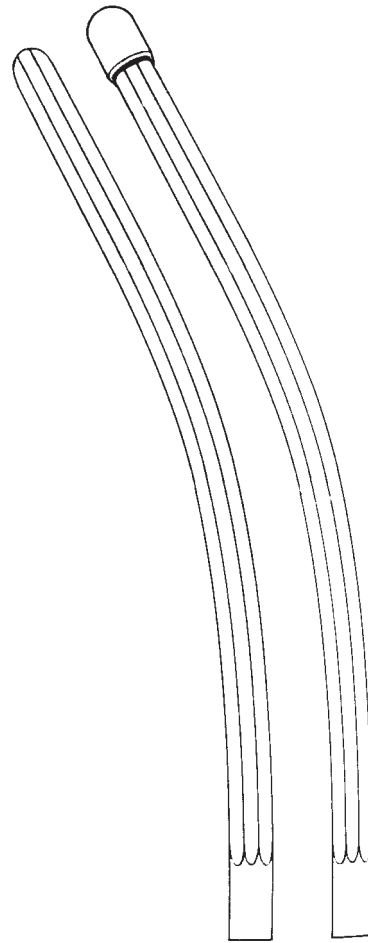

027-237-250
027-237-300

NUSSBAUM

027-236-250 - 027-237-250
027-236-300 - 027-237-300

25,0 cm / 9³/₄"
30,0 cm / 11³/₄"

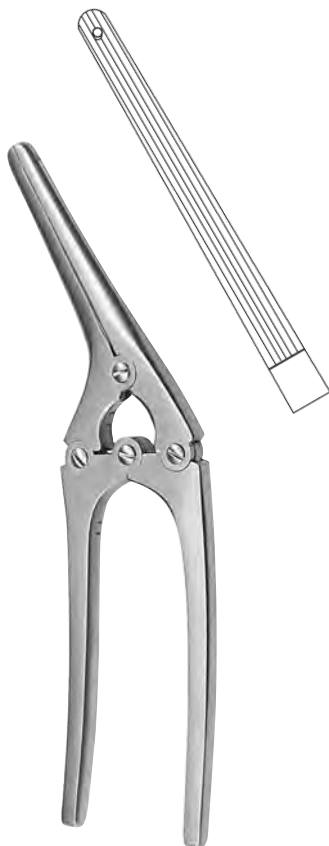

PAYR-BABY

027-240-150 15,0 cm / 6"

mit Stift
with pin
con espiga
con perno

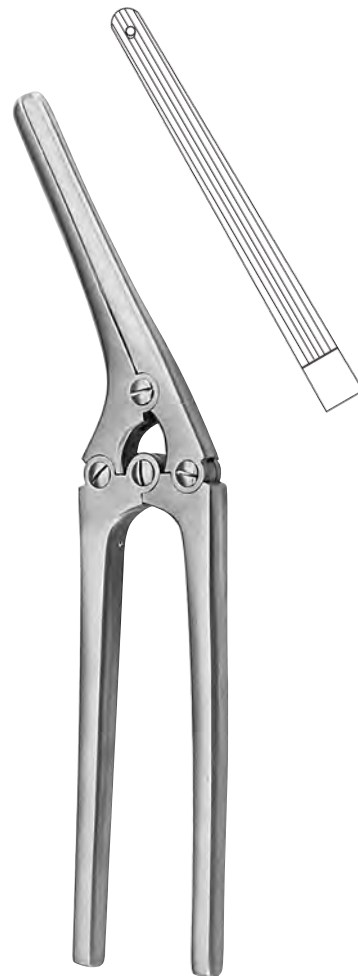

PAYR

027-250-210 21,0 cm / 8¹/₄"

027-250-290 29,0 cm / 11¹/₃"

027-250-350 35,0 cm / 13³/₄"

mit Stift
with pin
con espiga
con perno



027

Klemmen
Clamps
Pinzas
Pinze

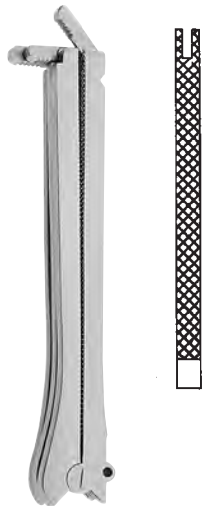

DE MARTEL-WOLFSON

027-260-005 5,0 cm / 2"
027-260-007 7,0 cm / 2 1/2"
027-260-100 10,0 cm / 4"



DE MARTEL-WOLFSON

027-261-260 26,0 cm / 10 1/4"



DE MARTEL-WOLFSON

027-270-085 8,5 cm / 3 1/2"

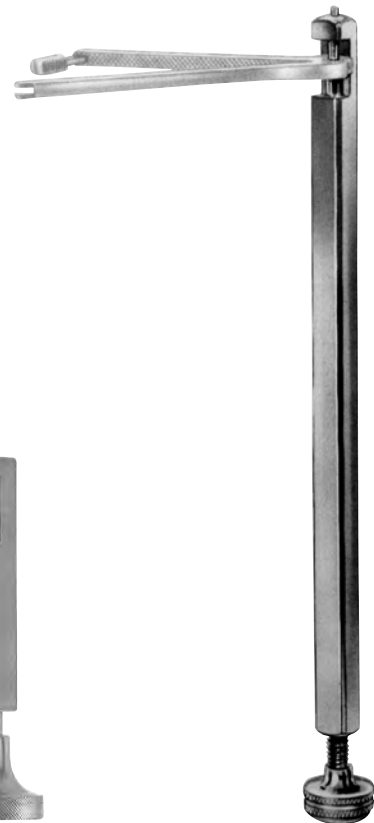

DE MARTEL-WOLFSON

027-270-230 23,0 cm / 9"

ATRAUMA

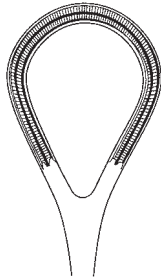

027-300-250 25,0 cm / 9³/₄"

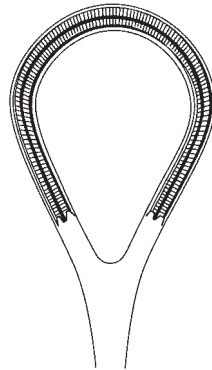

027-300-260 26,0 cm / 10¹/₄"



027-304-180 18,0 cm / 7"

schmal
narrow
estrecho
stretto

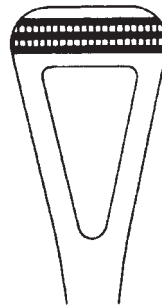

027-304-205 20,5 cm / 8"

mittel
medium
mediano
medio

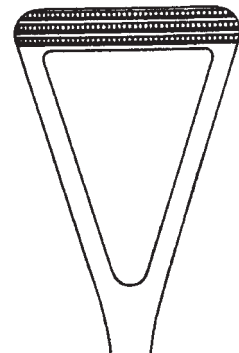

027-304-230 23,0 cm / 9"

breit
wide
ancho
largo

SCHEIBE



027

Darm- und Gewebefasszangen
Intestinal and Tissue Grasping Forceps
Pinzas intestinales y para tejidos
Pinze da presa per intestino e tessuti

ATRAUMA

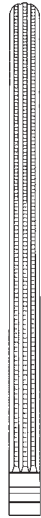

027-310-130

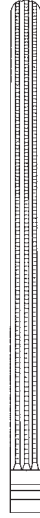

027-310-160

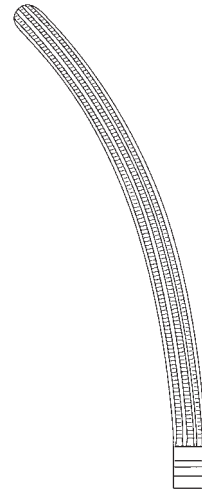

027-311-130

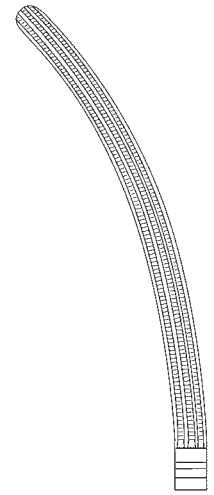

027-311-160

BABY-DOYEN

027-310-130 - 027-311-130 13,0 cm / 5¹/₈"
027-310-160 - 027-311-160 16,0 cm / 6¹/₄"



027-314-180

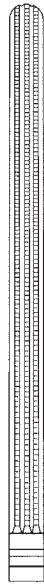

027-314-210



027-314-230

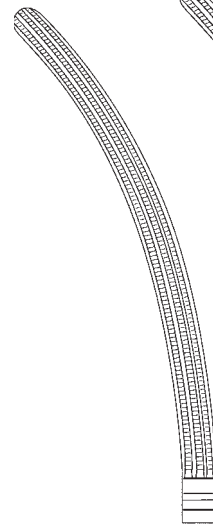

027-315-180

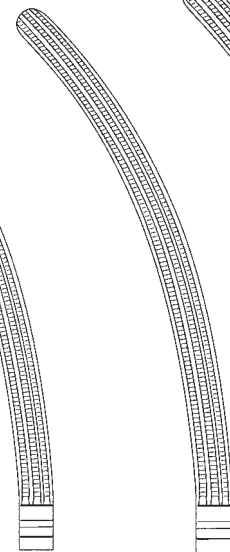

027-315-210

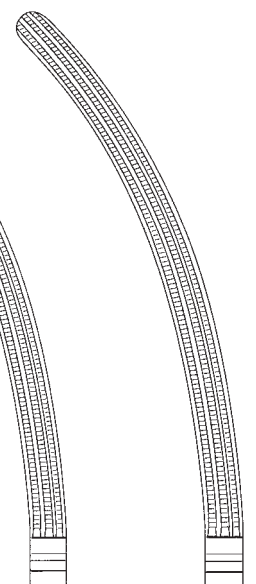

027-315-230

DOYEN

027-314-180 - 027-315-180 18,0 cm / 7"
027-314-210 - 027-315-210 21,0 cm / 8¹/₄"
027-314-230 - 027-315-230 23,0 cm / 9"

ATRAUMA

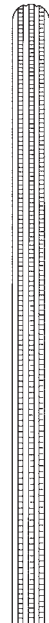

027-320-250

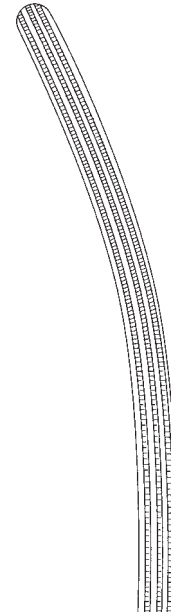

027-321-250

MAYO-ROBSON

027-320-250 - 027-321-250

25,0 cm / 9³/₄"

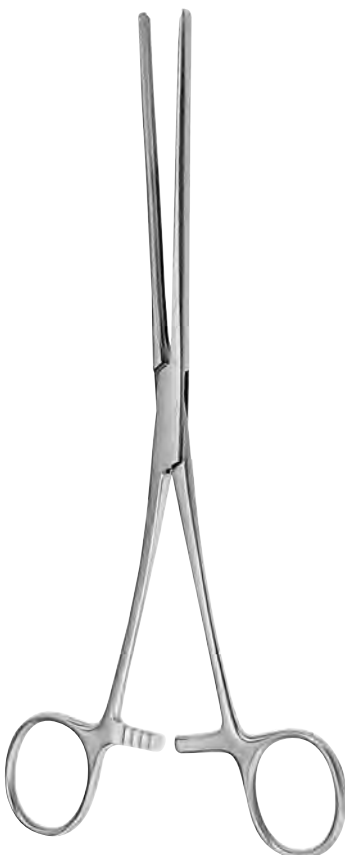

KOCHER

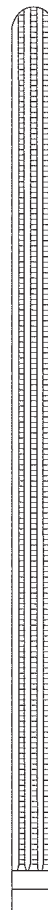

027-330-220 22,0 cm / 8³/₄"
027-330-250 25,0 cm / 9³/₄"
027-330-280 28,0 cm / 11"

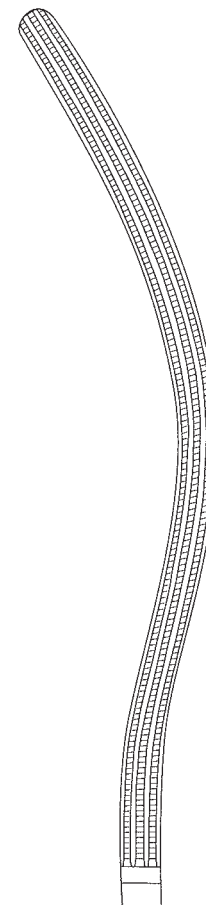

027-331-220 22,0 cm / 8³/₄"
027-331-250 25,0 cm / 9³/₄"
027-331-280 28,0 cm / 11"



027

Klemmen
Clamps
Pinzas
Pinze

ATRAUMA

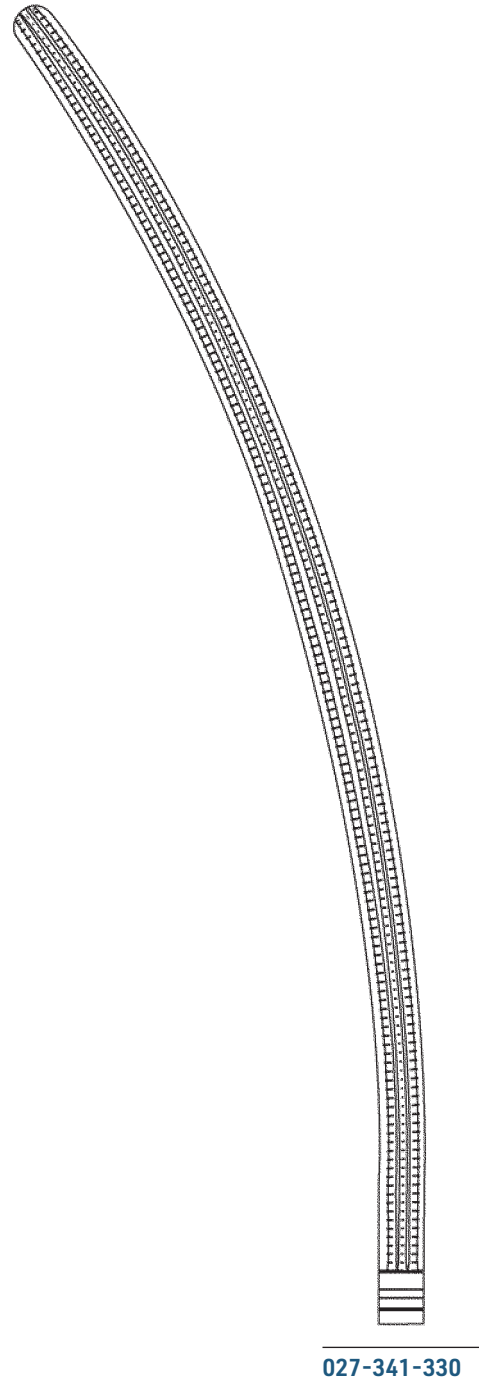
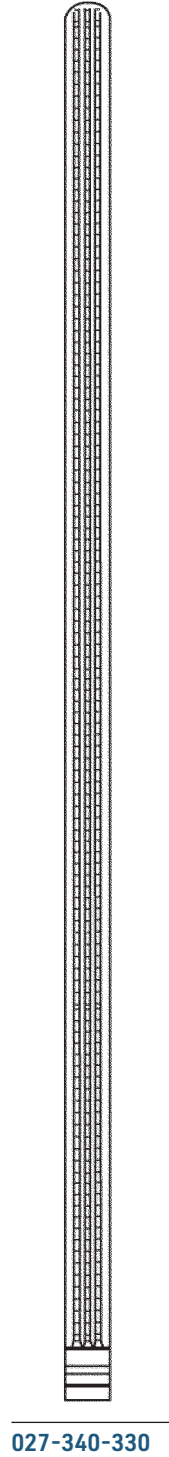

SCUDDER

027-340-330 - 027-341-330

33,0 cm / 13"

ATRAUMA



BRUNNER

027-345-240 24,0 cm / 9 1/2"

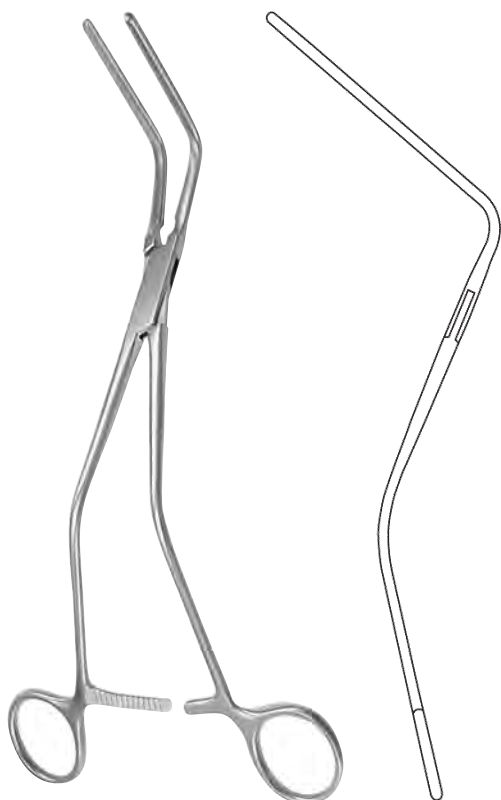
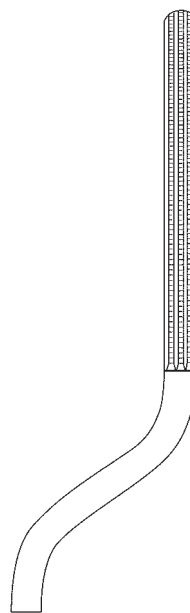

HAYES

027-349-260 - 027-349-280

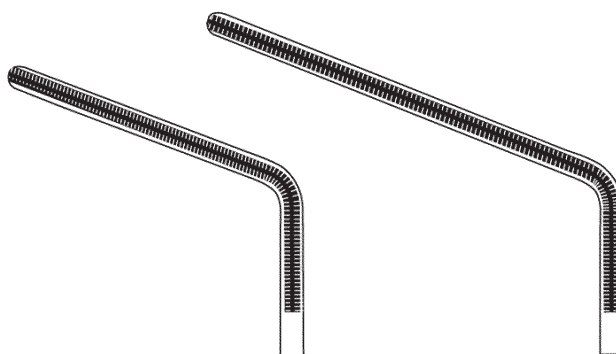

027-349-260 26,0 cm / 10"

027-349-280 28,0 cm / 11"



027

Klemmen
Forceps
Pinzas
Pinze

ATRAUMA

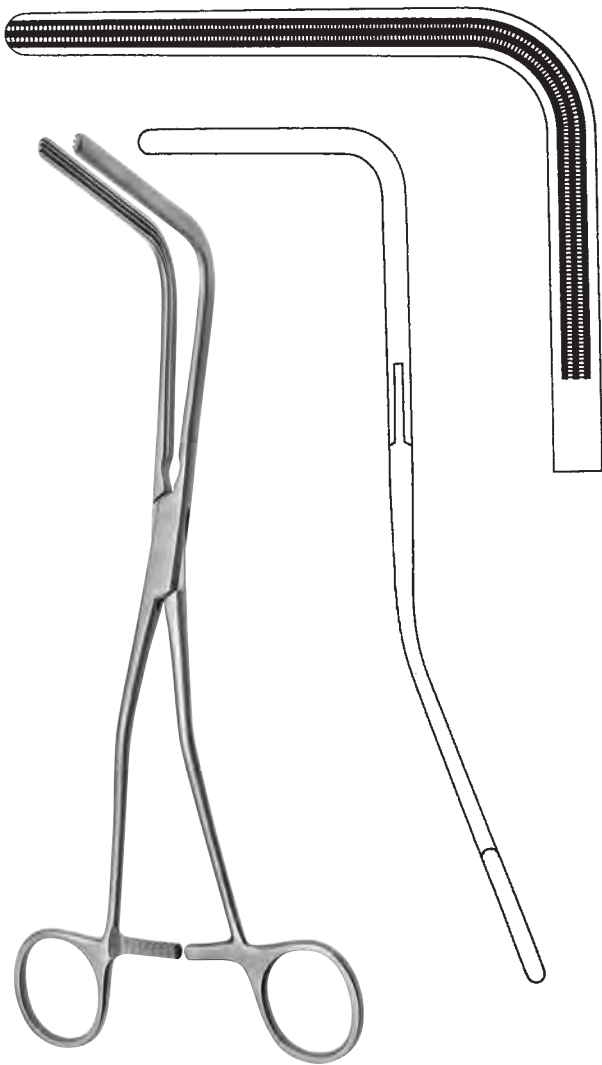

VEIDENHEIMER

027-351-250 25,0 cm / 9³/₄"



FEHLAND

027-353-240 24,0 cm / 9¹/₂"

ATRAUMA

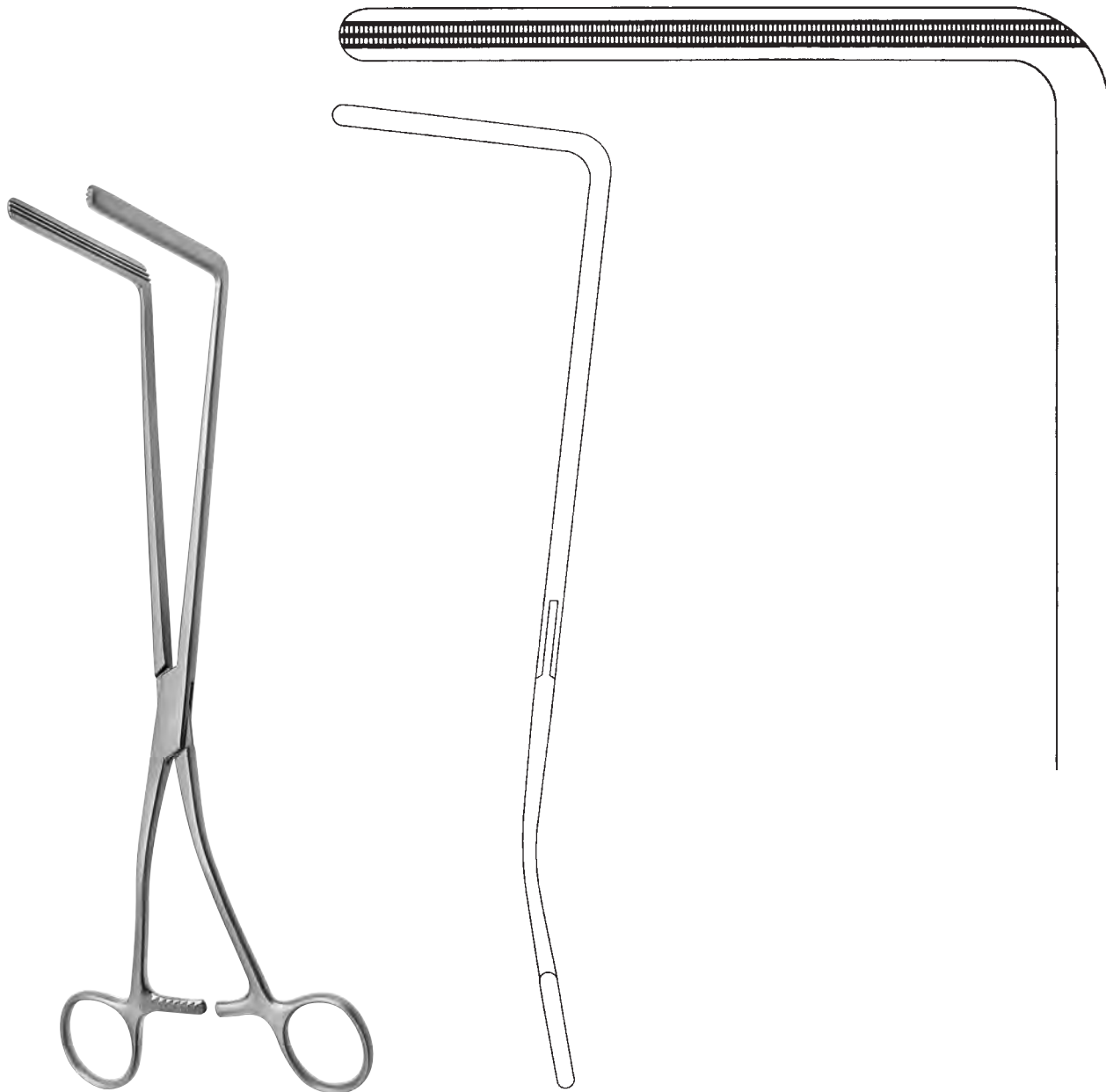

RESANO

027-355-300 30,0 cm / 11"



027

Mastdarm-Rektum-Spekula
Rectal Specula
Espéculos para el recto
Speculi rettali



CZERNY

027-400-220 22,0 cm / 9 1/2"



SIMS

027-402-150 15,0 cm / 6"



BODENHAMMER

027-404-150 15,0 cm / 6"



PRATT
027-408-200 20,0 cm / 8"



70 x 22 mm

BARR
027-410-170 17,0 cm / 6³/₄"



027

Mastdarm-Rektum-Spekula
Rectal Specula
Especúlos para el recto
Speculi rettali



MATHIEU

027-414-210 21,0 cm / 8 1/4"



SMITH BUIE

027-426-150 15,0 cm / 6"



SCHULZE-BERGMANN

027-420-060 - 027-420-125

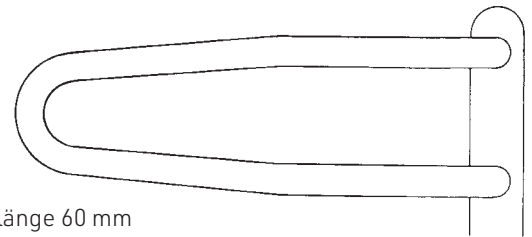

Valvenlänge 60 mm
Length of Blades 60 mm
Largo de valvas 60 mm
Lunghezza di valvi 60 mm

027-420-060

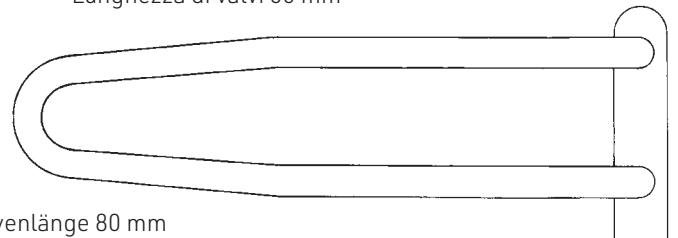

Valvenlänge 80 mm
Length of Blades 80 mm
Largo de valvas 80 mm
Lunghezza di valvi 80 mm

027-420-080

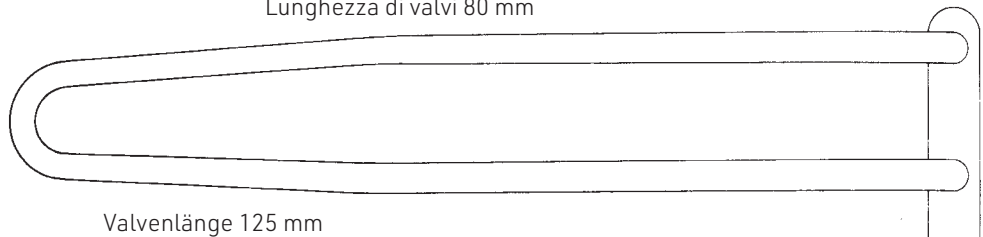

Valvenlänge 125 mm
Length of Blades 125 mm
Largo de valvas 125 mm
Lunghezza di valvi 125 mm

027-420-125

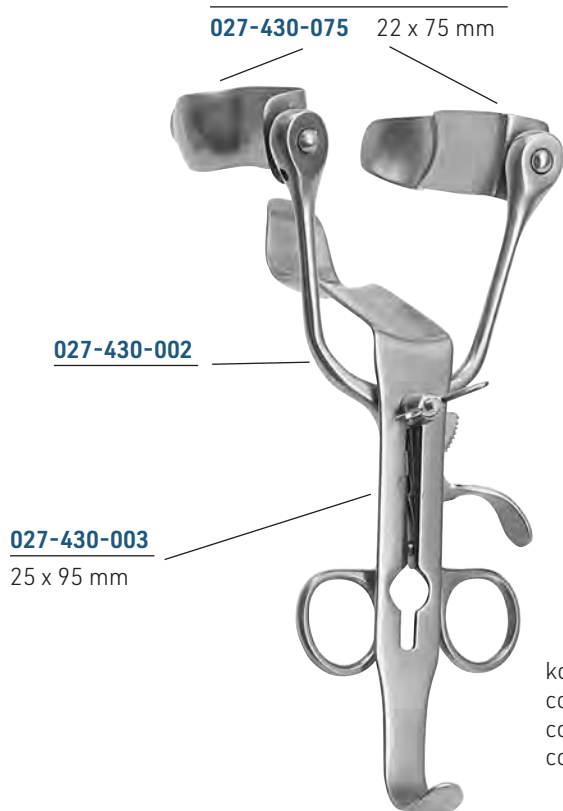

027-430-002

027-430-003
25 x 95 mm

027-430-075 22 x 75 mm

027-430-095 22 x 95 mm



ALAN PARKS

027-430-001 13,5 cm / 5³/₈"

komplett mit Kaltlichtträger
 complete with cold light carrier
 completo con portador para luz fria
 completo con supporto per luce fredda

komplett ohne Kaltlichtträger
 complete without cold light carrier
 completo sin portador para luz fria
 completo senza supporto per luce fredda

ALAN PARKS

027-430-000 13,5 cm / 5¹/₄"



ohne Kaltlichtträger
 without cold light carrier
 sin portador para luz fria
 senza supporto per luce fredda

IVES FANSLER

027-440-001 Ø 22 mm

027-440-003

Kunststoffobturator allein
 Obturator of plastic only
 Obturador de plastico suelto
 Otturatore di plastica solo

mit Kaltlichtträger
 with cold light carrier
 con portador para luz fria
 con supporto per luce fredda

IVES FANSLER

027-440-002 Ø 22 mm



HIRSCHMANN

027-444-001 Ø 16 x 65 mm

027-444-002 Ø 19 x 65 mm

027-444-003 Ø 22 x 70 mm



027

Analspreizer, Sphinkterskope, Anuskope
Rectal Retractor, Sphincteroscopes, Anoscopes
Separadores para el recto, Esfinteroscopios, Anoscopios
Dilatatori per l'ano e il retto, Sfinteroscopi, Anoscopi



KELLY

027-452-021 Ø 21 x 50 mm
027-452-027 Ø 27 x 50 mm



FANSLER

027-454-025 Ø 25 x 65 mm
027-454-029 Ø 29 x 65 mm
027-454-038 Ø 38 x 70 mm



PRATT

21,0 cm / 8 1/4"



027-460-001



027-460-002



027-460-003



YEOMAN

027-470-280 28,0 cm / 11"
027-470-350 35,0 cm / 13³/₄"
027-470-420 42,0 cm / 16¹/₂"

027-472-280 28,0 cm / 11"
027-472-350 35,0 cm / 13³/₄"
027-472-420 42,0 cm / 16¹/₂"



027-476-280 28,0 cm / 11"
027-476-350 35,0 cm / 13³/₄"
027-476-420 42,0 cm / 16¹/₂"

027-478-280 28,0 cm / 11"
027-478-350 35,0 cm / 13³/₄"
027-478-420 42,0 cm / 16¹/₂"

Haemorrhoiden-Ligator mit Ladekonus
 Haemorrhoidal ligator with loading attachment
 Ligador para hemorroides con cono de carga
 Legatori emorroidali con carica a cono

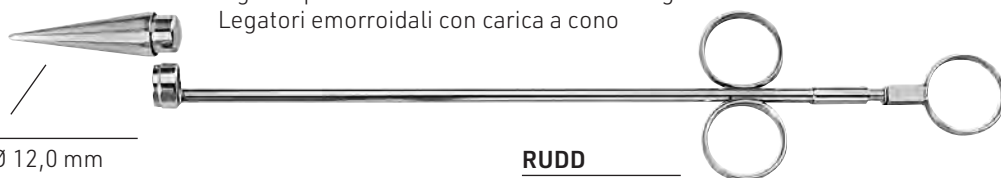

027-486-012 Ø 12,0 mm

RUDD
027-486-000

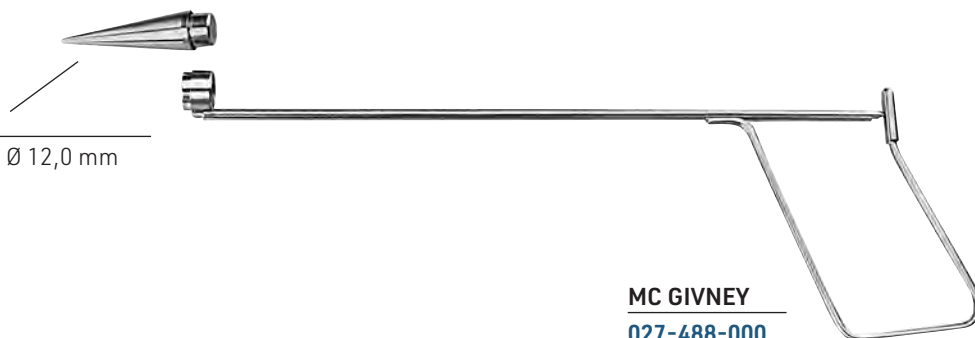

027-486-012 Ø 12,0 mm

MC GIVNEY
027-488-000



027-488-100
 Gummiringe 100
 Stück
 Rubber rings 100 pieces
 Anillos de goma 100 unidades
 Anelli di gomma 100 pezzi



027

Polypenfasszangen
Polypus Grasping Forceps
Pinzas para coger pólipos
Pinze per afferrare polipi

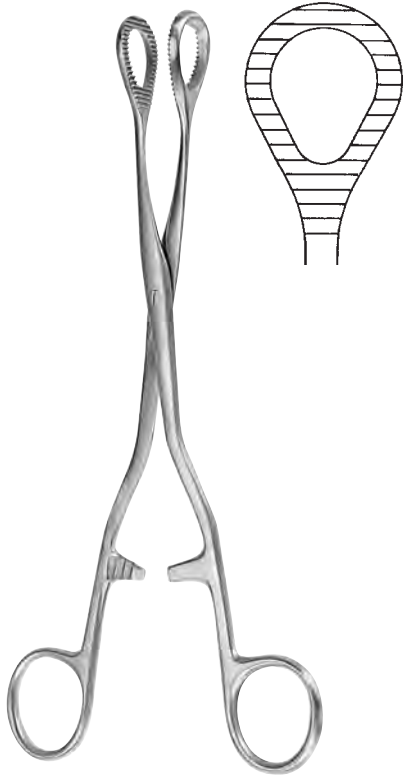

HEYWOOD-SMITH

027-490-210 21,0 cm / 8¹/₄"
027-490-250 25,0 cm / 9³/₄"

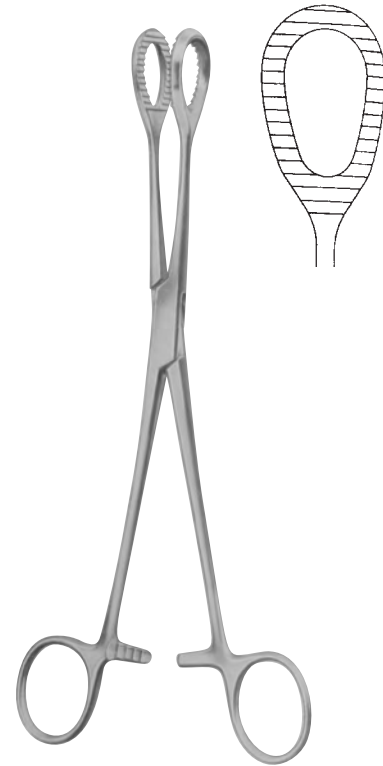

HEYWOOD-SMITH

027-492-210 21,0 cm / 8¹/₄"
027-492-250 25,0 cm / 9³/₄"

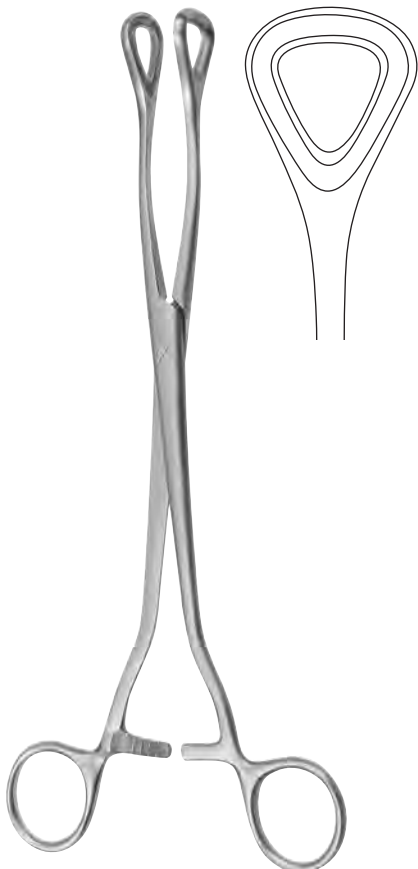

LUER

027-494-245 24,5 cm / 9²/₃"



MC GIVNEY

027-495-190 19,0 cm / 7¹/₂"



MC GIVNEY

027-497-190 19,0 cm / 7¹/₂"

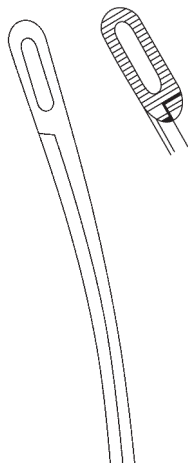

027-531-001 23,0 cm / 9"

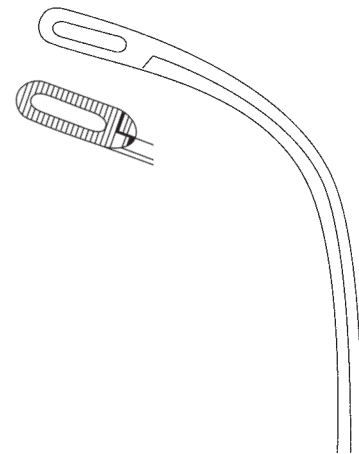

027-531-002 22,0 cm / 8⁵/₈"



RANDALL

027-531-001 - 027-531-004

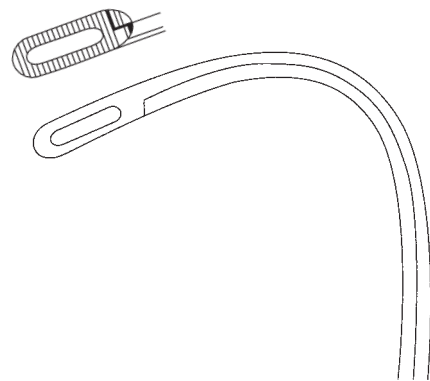

027-531-003 19,0 cm / 7¹/₂"

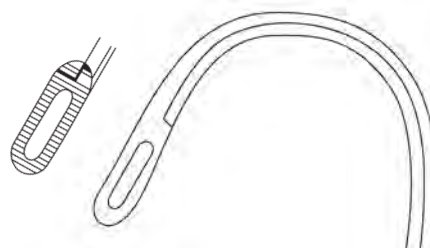

027-531-004 19,0 cm / 7¹/₂"



027

Nierensteinzangen, Gallensteinzangen
Kidney Stone Forceps, Gall Stone Forceps
Pinzas para los cálculos renales, Pinzas para los cálculos biliares
Pinze per calcoli renali, Pinze per calcoli biliari

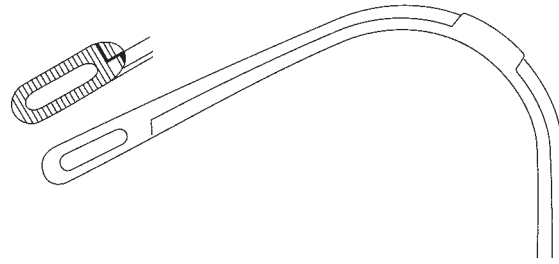

027-531-005

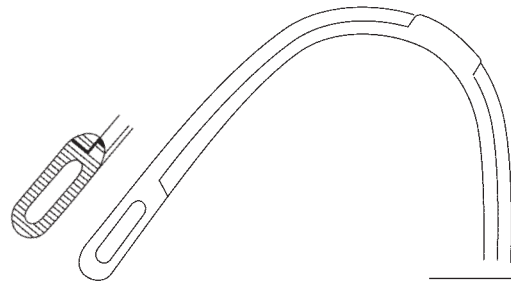

027-531-006

RANDALL

027-531-005 - 027-531-006

19,0 cm / 7 1/2"

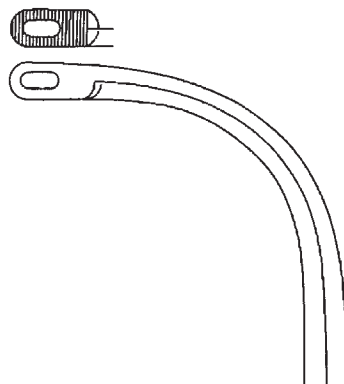

027-535-160 16,0 cm / 6 1/4"



027-535-170 17,0 cm / 6 3/4"

HEIMING

027-535-160 - 027-535-170

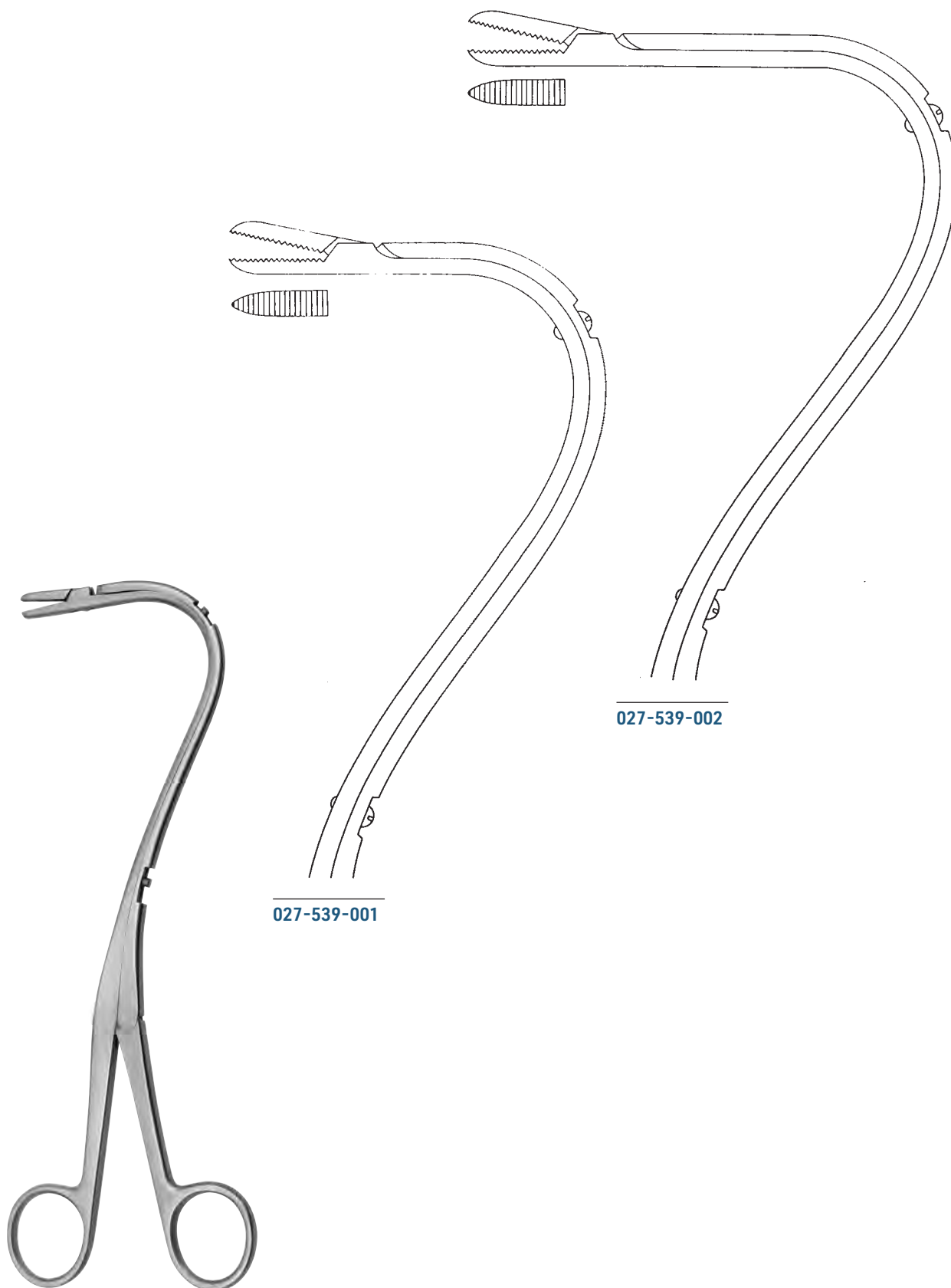

ELSÄSSER

027-539-001 - 027-539-002

21,0 cm / 8 1/4"



027

Gallengang Dilatatore
 Common Bile Duct Dilators
 Dilatadores para el conducto biliar
 Dilatatori per coledoco



027-540-001 Ø 1,0 mm



027-540-002 Ø 2,0 mm



027-540-003 Ø 3,0 mm



027-540-004 Ø 4,0 mm



027-540-005 Ø 5,0 mm



027-540-006 Ø 6,0 mm



027-540-007 Ø 7,0 mm



027-540-008 Ø 8,0 mm



027-540-009 Ø 9,0 mm



027-540-010 Ø 10,0 mm



027-540-011 Ø 11,0 mm



027-540-012 Ø 12,0 mm



027-540-013 Ø 13,0 mm



biegsamer Schaft
 malleable shaft
 vastago maleable
 asta malleabile

027-540-000

Satz à 9 Stück ø 3,0 -11,0 mm
 set of 9 pieces ø 3,0 -11,0 mm
 juego de 9 piezas ø 3,0 -11,0 mm
 set di 9 pezzi ø 3,0 -11,0 mm

BAKES

027-540-001 - 027-540-013 30,0 cm / 11³/₄"



biegsam
 malleable
 maleable
 malleabile

MOYNIHAN

027-544-340 34,0 cm / 13³/₄"

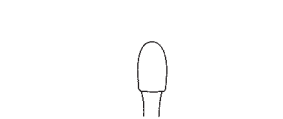

027-546-013 13 Charr.



027-546-018 18 Charr.



027-546-021 21 Charr.

federnd
 flexible
 flexible
 flessibile

DESJARDINS

027-546-013 - 027-546-021 28,0 cm / 11"



biegsam
 malleable
 maleable
 malleabile

MAYO

027-548-320 32,0 cm / 12¹/₂"



027

Gallensteinzangen
Gall Stone Forceps
Pinzas para los cálculos biliares
Pinze per calcoli biliari



CZERNY

027-551-245 24,5 cm / 9⁵/₈"



TURNER-WARWICK

027-553-180 18,0 cm / 7"
027-553-190 19,0 cm / 7¹/₂"

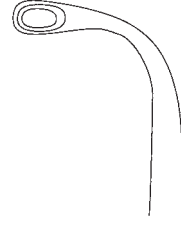

027-553-180

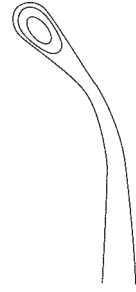

027-553-190



BLAKE

027-556-200 - 027-557-200 20,0 cm / 8"



027-557-200



MAYO-BLAKE

027-560-200 - 027-561-200 20,0 cm / 8"



027-561-200



MIXTER
027-563-220 22,0 cm / 8³/₄"



DESJARDINS
027-565-001 - 027-565-002 23,0 cm / 9"



STILLE
027-567-245 24,5 cm / 9²/₃"

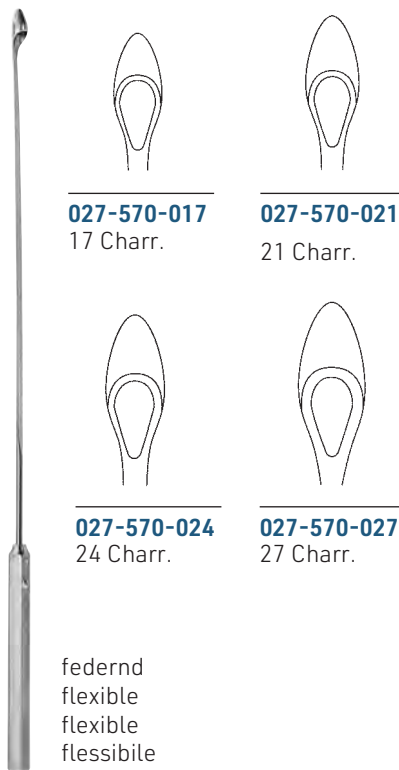

027-570-017 17 Charr.
027-570-021 21 Charr.
027-570-024 24 Charr.
027-570-027 27 Charr.

federnd
 flexible
 flexible
 flessibile

DESJARDINS
027-570-017 - 027-570-027 30,0 cm / 11³/₄"

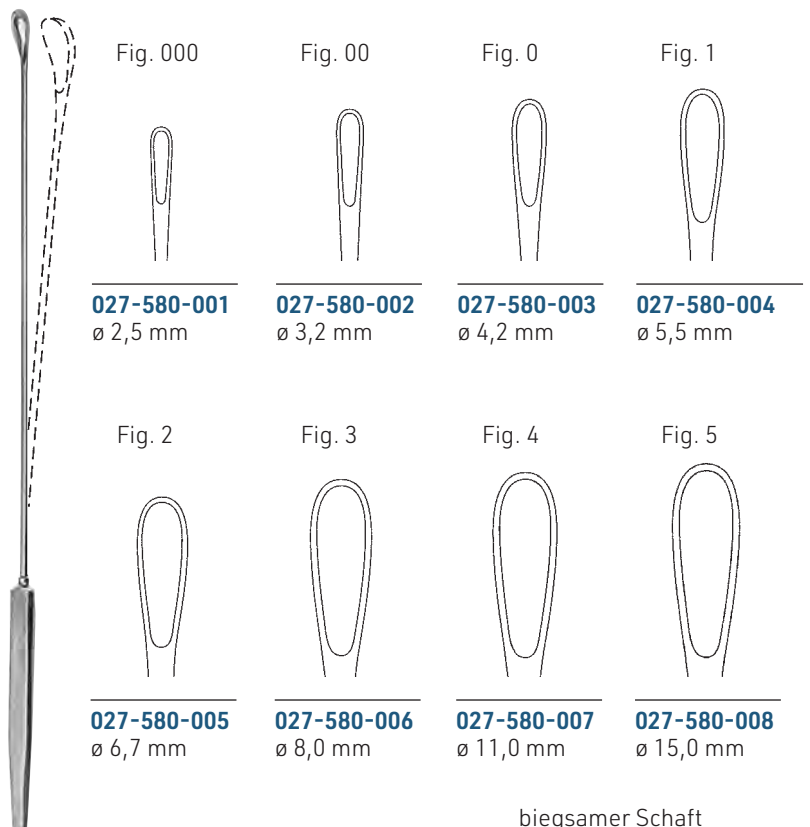

Fig. 000 Fig. 00 Fig. 0 Fig. 1
027-580-001 ø 2,5 mm **027-580-002** ø 3,2 mm **027-580-003** ø 4,2 mm **027-580-004** ø 5,5 mm
 Fig. 2 Fig. 3 Fig. 4 Fig. 5
027-580-005 ø 6,7 mm **027-580-006** ø 8,0 mm **027-580-007** ø 11,0 mm **027-580-008** ø 15,0 mm

LUER-KÖRTE
027-580-001 - 027-580-008 32,0 cm / 12¹/₂"

biegsamer Schaft
 malleable shaft
 vastago malleabile
 asta malleabile



027

Gallensteinlöffel
Gall Stone Scoops
Cucharillas para los cálculos biliares
Cucchiai per calcoli biliari



Gallenblasenlöffel
Gall bladder scoope
Cuccharilla para la vesicula biliar
Cucchiaio pre colecisti

MOORE

027-582-300 30,0 cm / 12"



MAYO

027-584-280 28,0 cm / 11"



FERGUSSON

027-586-215 21,5 cm / 8 1/2"



YOUNG

027-701-210 21,0 cm / 8¹/₄"



YOUNG

027-703-220 22,0 cm / 8⁵/₈"



YOUNG

027-705-210 21,0 cm / 8¹/₄"



YOUNG

027-707-220 22,0 cm / 8⁵/₈"



YOUNG

027-710-200 20,0 cm / 8"



ATRAUMA



MILLIN

027-711-240 24,0 cm / 9 1/2"



ATRAUMA



MILLIN

027-713-240 24,0 cm / 9 1/2"

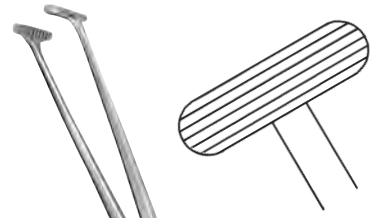

MILLIN

027-715-240 24,0 cm / 9 1/2"

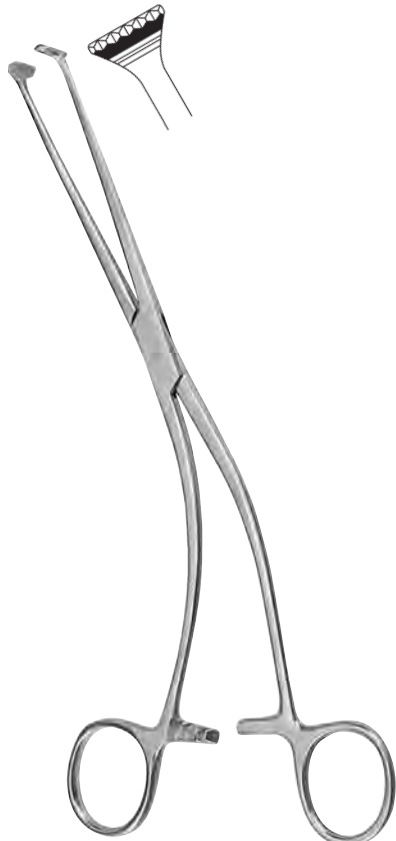

MILLIN

027-717-230 23,0 cm / 9"

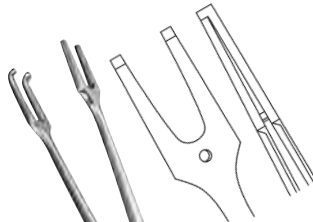

MILLIN

027-719-240 24,0 cm / 9 1/2"



MILLIN

027-725-285 28,5 cm / 11 1/4"

JUDD-MASSON

027-740-000

ohne Mittelblatt
without central blade
sin valva central
senza valva centrale



JUDD-MASSON

027-742-000

mit Mittelblatt
with central blade
con valva central
con valva centrale

027-742-001

75x25 mm

Mittelblatt
central blade
Valva central
Valva centrale

JUDD-MASSON

027-750-003

Seitenvalven
latral blades
Valvas laterales
Valva laterale

027-750-002

Seitenvalven
latral blades
Valvas laterales
Valva laterale

80x25 mm

57x25 mm

120x45 mm

027-750-004

Mittelblatt
central blade
Valva central
Valva centrale

027-750-001

Rahmen allein
Frame only
Cuadro suelto
telaio solo

120x45 mm

027-754-001

Kaltlichtaufsatz
cold light carrier
portador para luz fria
supporto per lucce fredda

MILLIN

027-750-000

MILLIN

027-754-000



027

Prostatahaken, Blasenspatel
Prostatic Retractors, Bladder Spatulas
Separadores para la prostata, Espátulas vesicales
Re Trattori prostatici, Spatole vescicali

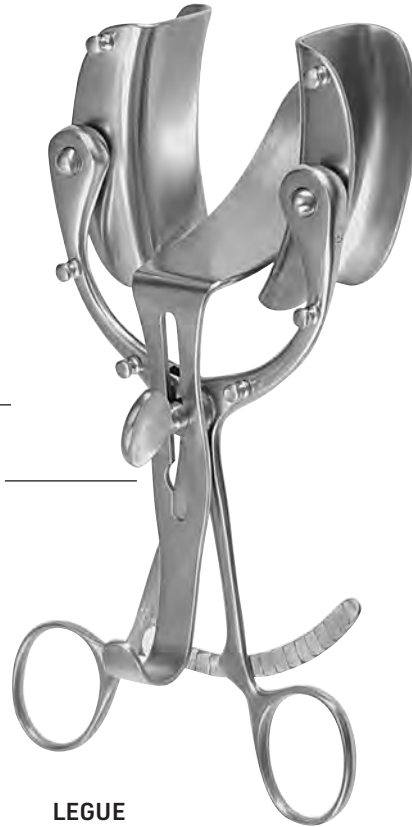

027-760-002 70 x 32 mm
Mittelvalve
center blade
Valva central
Valva centrale

027-760-001 28 x 60 mm
Seitenvalven
lateral blades
Valvas laterales
Valva laterale

LEGUE
027-760-000



LEGUEU
027-765-270 30,0 cm / 11¹/₄"



KOCHER
027-767-270 27,0 cm / 10³/₄"

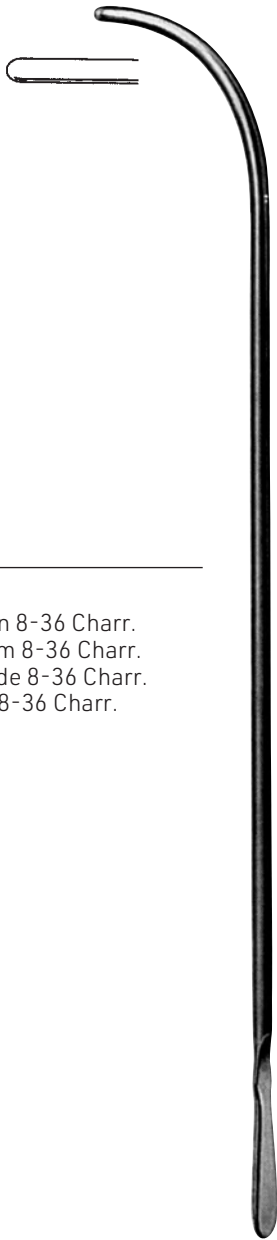

027-781-000

Satz komplett von 8-36 Charr.
 Set complete from 8-36 Charr.
 Juego completo de 8-36 Charr.
 Set completo da 8-36 Charr.

VAN BUREN

027-781-008	Ø 2 ² / ₃ mm	Char. 8
027-781-010	Ø 3 ¹ / ₃ mm	Char. 10
027-781-012	Ø 4 mm	Char. 12
027-781-014	Ø 4 ² / ₃ mm	Char. 14
027-781-016	Ø 5 ¹ / ₃ mm	Char. 16
027-781-018	Ø 6 mm	Char. 18
027-781-020	Ø 6 ² / ₃ mm	Char. 20
027-781-022	Ø 7 ¹ / ₃ mm	Char. 22
027-781-024	Ø 8 mm	Char. 24
027-781-026	Ø 8 ² / ₃ mm	Char. 26
027-781-028	Ø 9 ¹ / ₃ mm	Char. 28
027-781-030	Ø 10 mm	Char. 30
027-781-032	Ø 10 ² / ₃ mm	Char. 32
027-781-034	Ø 11 ¹ / ₃ mm	Char. 34
027-781-036	Ø 12 mm	Char. 36

GUYON

027-791-012	Ø 4 mm	Char. 12
027-791-013	Ø 4 ¹ / ₃ mm	Char. 13
027-791-014	Ø 4 ² / ₃ mm	Char. 14
027-791-015	Ø 5 mm	Char. 15
027-791-016	Ø 5 ¹ / ₃ mm	Char. 16
027-791-017	Ø 5 ² / ₃ mm	Char. 17
027-791-018	Ø 6 mm	Char. 18
027-791-019	Ø 6 ¹ / ₃ mm	Char. 19
027-791-020	Ø 6 ² / ₃ mm	Char. 20
027-791-021	Ø 7 mm	Char. 21
027-791-022	Ø 7 ¹ / ₃ mm	Char. 22
027-791-023	Ø 7 ² / ₃ mm	Char. 23
027-791-024	Ø 8 mm	Char. 24
027-791-025	Ø 8 ¹ / ₃ mm	Char. 25
027-791-026	Ø 8 ² / ₃ mm	Char. 26
027-791-027	Ø 9 mm	Char. 27
027-791-028	Ø 9 ¹ / ₃ mm	Char. 28
027-791-029	Ø 9 ² / ₃ mm	Char. 29
027-791-030	Ø 10 mm	Char. 30



027

Metallkatheter
Metal Catheters
Sondas metalicas
Cateteri metalliche



für Männer
for male
para hombres
per uomini

27,0 cm / 10³/₄"

027-801-008	Char. 8	ø 2 ² / ₃ mm
027-801-010	Char. 10	ø 3 ¹ / ₃ mm
027-801-012	Char. 12	ø 4 mm
027-801-014	Char. 14	ø 4 ² / ₃ mm
027-801-016	Char. 16	ø 5 ¹ / ₃ mm
027-801-018	Char. 18	ø 6 mm
027-801-020	Char. 20	ø 6 ² / ₃ mm
027-801-022	Char. 22	ø 7 ¹ / ₃ mm
027-801-024	Char. 24	ø 8 mm



für Frauen
for female
para mujeres
per donne

15,0 cm / 6"

027-811-006	Char. 6	ø 2 mm
027-811-007	Char. 7	ø 2 ¹ / ₃ mm
027-811-008	Char. 8	ø 2 ² / ₃ mm
027-811-009	Char. 9	ø 3 mm
027-811-010	Char. 10	ø 3 ¹ / ₃ mm
027-811-011	Char. 11	ø 3 ² / ₃ mm
027-811-012	Char. 12	ø 4 mm
027-811-013	Char. 13	ø 4 ¹ / ₃ mm
027-811-014	Char. 14	ø 4 ² / ₃ mm
027-811-015	Char. 15	ø 5 mm
027-811-016	Char. 16	ø 5 ¹ / ₃ mm
027-811-018	Char. 18	ø 6 mm
027-811-020	Char. 20	ø 6 ² / ₃ mm
027-811-022	Char. 22	ø 7 ¹ / ₃ mm
027-811-024	Char. 24	ø 8 mm



COMCO

- 027-830-008** ø 8,0 mm
- 027-830-011** ø 11,0 mm
- 027-830-013** ø 13,0 mm
- 027-830-016** ø 16,0 mm
- 027-830-021** ø 21,0 mm
- 027-830-026** ø 26,0 mm
- 027-830-032** ø 32,0 mm



KNUTSON

027-840-000

KNUTSON-KOCH

027-842-000

- Konus
- Cone
- Cono
- Cono



MOGEN

027-846-075 7,5 cm / 3"



GUYON

027-850-390 39,0 cm / 16"

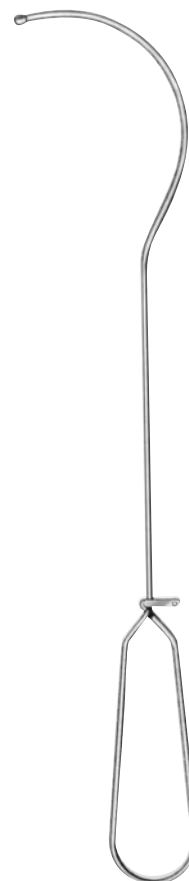

GUYON

027-851-350 35,0 cm / 13³/₄"



027

Klemmen, Fremdkörperzange
Clamp, Foreign Body Forceps
Compresor urétral, Pinzas
Serrapene, Pinze



STRAUSS

027-860-110 11,0 cm / 4¹/₃"



STOCKMANN

027-862-080 8,0 cm / 3¹/₄"

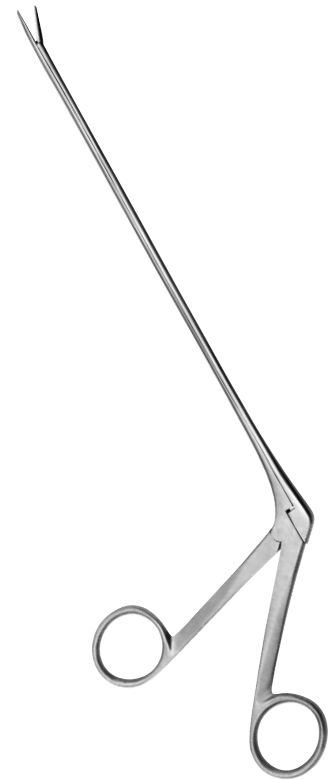

MATHIEU

027-870-200 20,0 cm / 8"
027-870-280 28,0 cm / 11"

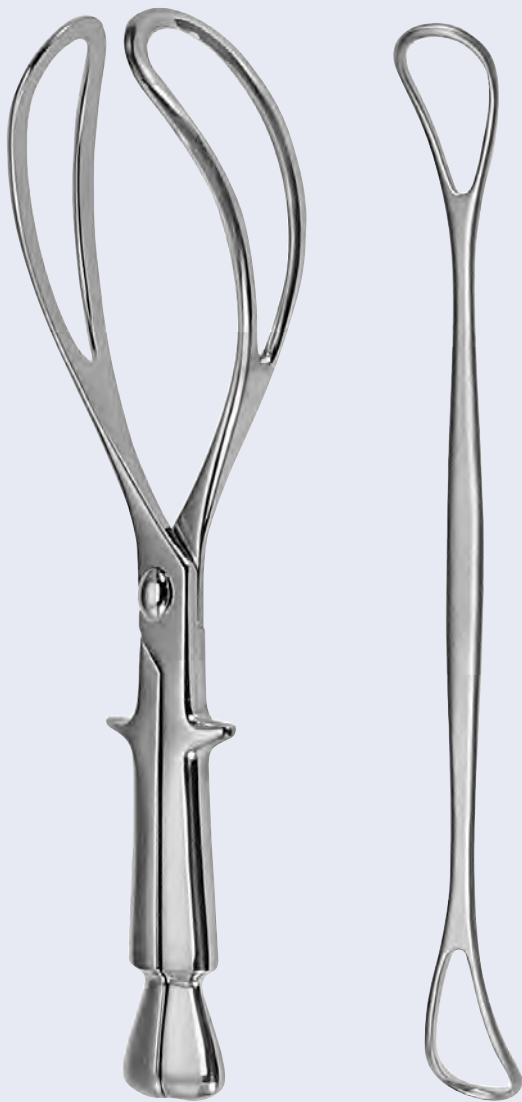

030

Gynäkologie, Geburtshilfe
Gynecology, Obstetrics
Ginecología, Ostetricia
Ginecologia, Ostetricia



030

Scheidenspekula
Vaginal Specula
Espéculos vaginales
Specoli vaginali



Schweizer Modell
Swiss pattern
Modelo suizo
Modello svizzero

CUSCO

030-010-001	80x22 mm
030-010-002	100x25 mm
030-010-003	105x27 mm



für Jungfrauen
for virgins
para vírgenes
per vergini

seitliche Stellschraube
lateral fixation screw
tornillo de sujeto lateral
vite di regolazione laterale

CUSCO

030-012-001	75x17 mm
--------------------	----------



zentrale Stellschraube
central fixation screw
tornillo de sujeto central
vite di regolazione centrale

CUSCO

030-020-001	75x32 mm
030-020-002	85x35 mm
030-020-003	100x37 mm



seitliche Stellschraube
lateral fixation screw
tornillo de sujeto lateral
vite di regolazione laterale

CUSCO

030-030-001	75x32 mm
030-030-002	85x35 mm
030-030-003	100x35 mm



CUSCO STANDARD

030-040-001	80x24 mm
030-040-002	80x32 mm
030-040-003	85x36 mm
030-040-004	110x37 mm



für Kinder
 for children
 para niñas
 per bambini

COLLIN

030-050-001	55x10 mm
--------------------	----------



COLLIN

030-052-001	55x10 mm
030-052-002	65x20 mm

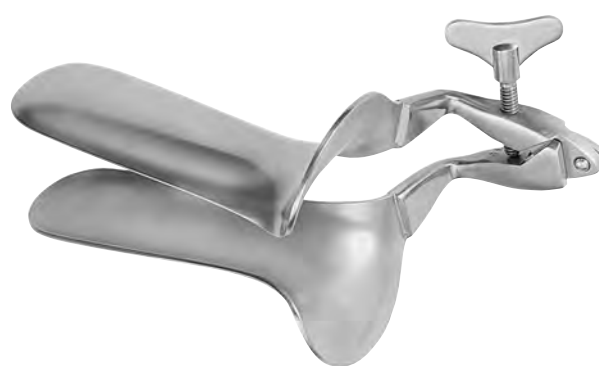

COLLIN

030-054-001	85x30 mm
030-054-002	100x35 mm
030-054-003	110x40 mm



030

Scheidenspekula
Vaginal Specula
Especulos vaginales
Specoli vaginali



GRAVE

030-060-001	75x20 mm
030-060-002	95x35 mm
030-060-003	115x35 mm



PEDERSON

030-070-001	75x13 mm
030-070-002	100x22 mm
030-070-003	120x25 mm



SEMM

030-075-001	90x14-18 mm
030-075-002	100x17-20 mm
030-075-003	100x25-30 mm



SEYFFERT

030-080-001	100x17 mm	Fig.1
030-080-002	110x33 mm	Fig.2



TRELAT

030-085-001	85x33 mm	Fig.1
030-085-002	95x35 mm	Fig.2
030-085-003	115x43 mm	Fig.3

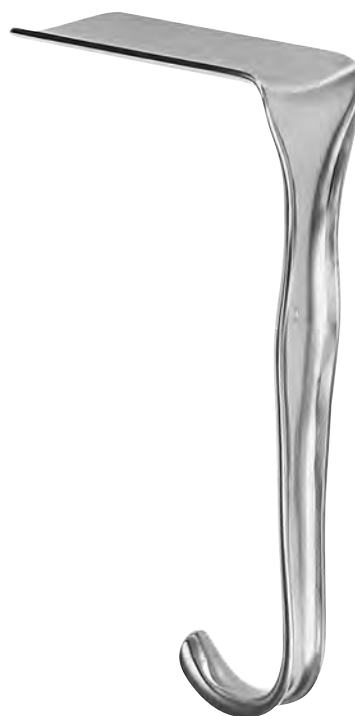

JACKSON

030-090-001	75x35 mm	Fig.1
030-090-002	90x35 mm	Fig.2
030-090-003	100x35 mm	Fig.3



JACKSON

030-092-001	75x40 mm	Fig.1
030-092-002	90x40 mm	Fig.2
030-092-003	100x40 mm	Fig.3



EASTMAN

030-094-001	75x35 mm	Fig.1
030-094-002	90x35 mm	Fig.2
030-094-003	100x35 mm	Fig.3



EASTMAN

030-096-001	75x40 mm	Fig.1
030-096-002	90x40 mm	Fig.2
030-096-003	100x40 mm	Fig.3



030

Scheidenspekula
Vaginal Specula
Espéculos vaginales
Specoli vaginali



SIMS

030-100-000

Satz
Set
Juego
Set



60x30 mm

60x25 mm

SIMS

030-100-001 12,5 cm / 5"



70x35 mm

70x30 mm

SIMS

030-100-002 15,0 cm / 6"



80x40 mm

80x35 mm

SIMS

030-100-003 17,5 cm / 7"



SIMS

030-102-001 Fig.1 70x25 mm
030-102-002 Fig.2 85x30 mm
030-102-003 Fig.3 100x40 mm



KRISTELLER

- 030-110-001** 70x27 mm
- 030-110-002** 75x30 mm
- 030-110-003** 90x36 mm



KRISTELLER

- 030-111-001** 75x23 mm
- 030-111-002** 80x26 mm
- 030-111-003** 95x32 mm



KRISTELLER

Satz/Set/juego/set

- 030-115-001** 70x27 mm + 75x23 mm
- 030-115-002** 75x30 mm + 80x26 mm
- 030-115-003** 90x36 mm + 95x32 mm



tiefes Spekulum
 deep speculum
 espéculo profundo
 Specolo profondo

KRISTELLER

- 030-120-001** 110x27 mm
- 030-120-002** 110x30 mm
- 030-120-003** 110x36 mm



KRISTELLER

- 030-121-001** 115x23 mm
- 030-121-002** 115x26 mm
- 030-121-003** 115x32 mm



KRISTELLER

- 030-125-001** 110x27 mm + 115x23 mm
- 030-125-002** 110x30 mm + 115x26 mm
- 030-125-003** 110x36 mm + 115x32 mm



030

Scheidenspekula
Vaginal Specula
Espéculos vaginales
Specoli vaginali

flaches Spekulum
flat speculum
espécule plano
specolo piatto



KRISTELLER

030-130-001 110x27 mm
030-130-002 110x30 mm
030-130-003 110x36 mm



KRISTELLER

030-131-001 115x23 mm
030-131-002 115x26 mm
030-131-003 115x32 mm



KRISTELLER Satz/Set/juego/set

030-135-001 110x27 mm + 115x23 mm
030-135-002 110x30 mm + 115x26 mm
030-135-003 110x36 mm + 115x32 mm



KRISTELLER

030-140-001 110x18 mm
030-140-002 110x21 mm



KRISTELLER

030-141-001 115x14 mm
030-141-002 115x17 mm



KRISTELLER Satz/Set/juego/set

030-145-001 110x18 mm + 115x14 mm
030-145-002 110x21 mm + 115x17 mm



030

Scheidenspekula
Vaginal Specula
Espéculos vaginales
Specoli vaginali



KRISTELLER
030-150-001 130x40 mm



KRISTELLER
030-151-001 135x36 mm



KRISTELLER Satz/Set/juego/set
030-155-001 130x40 mm + 135x36 mm



KRISTELLER
030-160-001 70x15 mm



KRISTELLER
030-161-001 75x10 mm



KRISTELLER Satz/Set/juego/Set
030-165-001 70x15 mm + 75x10 mm



030

Scheidenspekula
Vaginal Specula
Espéculos vaginales
Specoli vaginali



KALLMORGEN

030-170-001 70x40 mm
030-170-002 90x40 mm

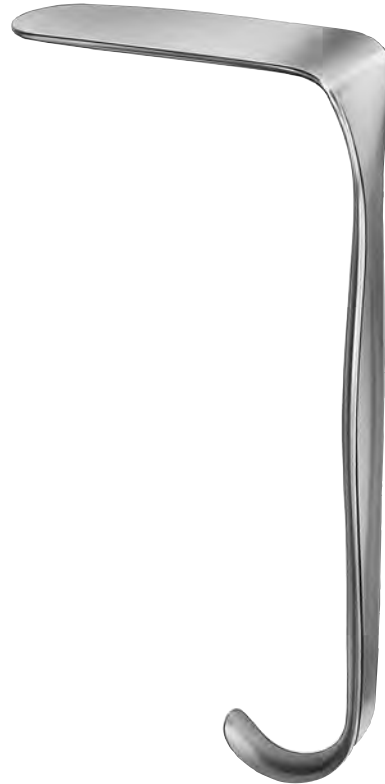

KALLMORGEN

030-171-001 70x33 mm
030-171-002 90x33 mm



KALLMORGEN Satz/Set/juego/set

030-175-001 70x40 mm + 70x33 mm
030-175-002 90x40 mm + 90x33 mm



Spekulum allein
 Speculum only
 Espèculo suelto
 Specolo solo

MATHIEU

030-180-001	95x16-26 mm
030-180-002	95x16-30 mm



Halter allein
 Retractor only
 Valva suelta
 Valva sola

MATHIEU

030-181-001	100x11/21 mm
030-181-002	100x14/27 mm

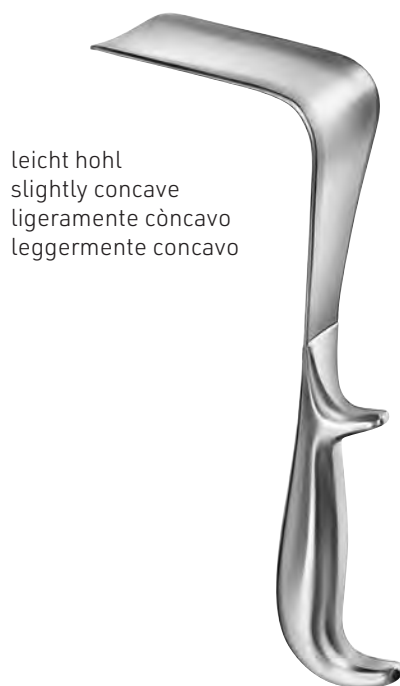

leicht hohl
 slightly concave
 ligeramente còncavo
 leggermente concavo

DOYEN

030-190-001	55x35	mm	Fig.1	24,0 cm / 9 1/2"
030-190-002	85x35	mm	Fig.2	24,0 cm / 9 1/2"
030-190-003	115x35	mm	Fig.3	24,0 cm / 9 1/2"
030-192-001	55x45	mm	Fig.1	24,0 cm / 9 1/2"
030-192-002	85x45	mm	Fig.2	24,0 cm / 9 1/2"
030-192-003	115x45	mm	Fig.3	24,0 cm / 9 1/2"
030-192-004	160x45	mm	Fig.4	24,0 cm / 9 1/2"
030-194-001	55x60	mm	Fig.1	24,0 cm / 9 1/2"
030-194-002	85x60	mm	Fig.2	24,0 cm / 9 1/2"
030-194-003	115x60	mm	Fig.3	24,0 cm / 9 1/2"
030-194-004	160x60	mm	Fig.4	24,0 cm / 9 1/2"



030

Scheidenspekula
Vaginal Specula
Espéculos vaginales
Specoli vaginali

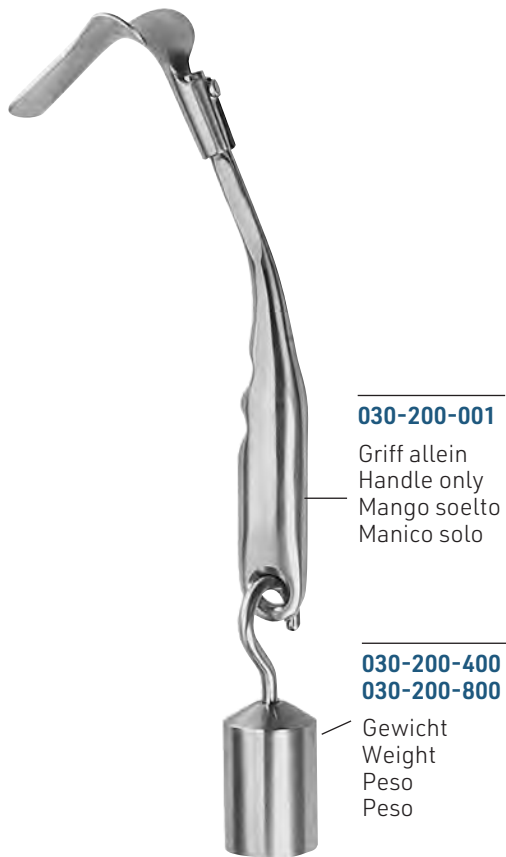

030-200-001

Griff allein
Handle only
Mango soletto
Manico solo

030-200-400 400g
030-200-800 800g

Gewicht
Weight
Peso
Peso

SCHERBAK
030-200-000

komplett
complete
completo
completo

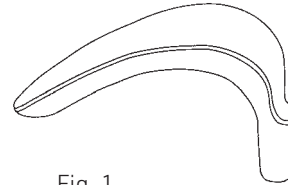

Fig. 1

030-200-030 80x30 mm

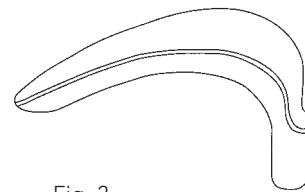

Fig. 2

030-200-035 85x35 mm

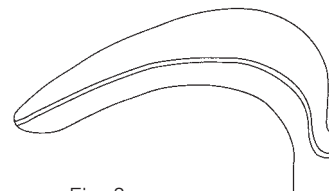

Fig. 3

030-200-040 90x40 mm

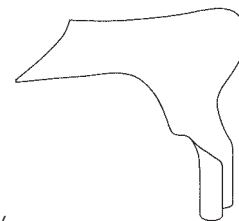

Fig. 4

030-200-060 55x40/60 mm

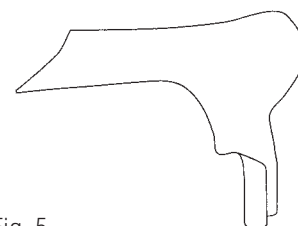

Fig. 5

030-200-070 70x45/70 mm

mit festem Gewicht
with fixed weight
con peso fijo
con peso fisso



AUVARD

030-210-000 90x45 mm

mit abnehmbarem Gewicht
with detachable weight
con peso desmontable
con peso smontabile



AUVARD

030-212-000 80x38 mm

80x42 mm

mit abnehmbarem Auffangsieb
with removable strainer
con tamiz desmontable
con filtro smontabile



WEISSBARTH

030-216-000 21,0 cm / 8¹/₄"



030

Scheidenspekula
Vaginal Specula
Especulos vaginales
Specoli vaginali



BREISKY

030-221-020	100x20 mm	30,0 cm / 12"
030-221-025	100x25 mm	30,0 cm / 12"
030-221-030	100x30 mm	30,0 cm / 12"
030-221-035	100x35 mm	30,0 cm / 12"
030-221-040	100x40 mm	30,0 cm / 12"
030-223-020	130x20 mm	32,0 cm / 12 ³ / ₄ "
030-223-025	130x25 mm	32,0 cm / 12 ³ / ₄ "
030-223-030	130x30 mm	32,0 cm / 12 ³ / ₄ "
030-223-035	130x35 mm	32,0 cm / 12 ³ / ₄ "
030-223-040	130x40 mm	32,0 cm / 12 ³ / ₄ "
030-225-040	155x40 mm	35,0 cm / 14"

LANDAU

030-229-028	100x28 mm	29,0 cm / 11 ¹ / ₂ "
030-229-038	100x38 mm	29,0 cm / 11 ¹ / ₂ "

DOYEN

030-231-250	25,0 cm / 9"
--------------------	--------------



HEGAR

030-240-001	Ø 1,0 mm	18,5 cm / 7 ¹ / ₄ "
030-240-002	Ø 2,0 mm	18,5 cm / 7 ¹ / ₄ "
030-240-003	Ø 3,0 mm	18,5 cm / 7 ¹ / ₄ "
030-240-004	Ø 4,0 mm	18,5 cm / 7 ¹ / ₄ "
030-240-005	Ø 5,0 mm	18,5 cm / 7 ¹ / ₄ "
030-240-006	Ø 6,0 mm	18,5 cm / 7 ¹ / ₄ "
030-240-007	Ø 7,0 mm	18,5 cm / 7 ¹ / ₄ "
030-240-008	Ø 8,0 mm	18,5 cm / 7 ¹ / ₄ "
030-240-009	Ø 9,0 mm	18,5 cm / 7 ¹ / ₄ "
030-240-010	Ø 10,0 mm	18,5 cm / 7 ¹ / ₄ "
030-240-011	Ø 11,0 mm	18,5 cm / 7 ¹ / ₄ "
030-240-012	Ø 12,0 mm	18,5 cm / 7 ¹ / ₄ "
030-240-013	Ø 13,0 mm	18,5 cm / 7 ¹ / ₄ "
030-240-014	Ø 14,0 mm	18,5 cm / 7 ¹ / ₄ "
030-240-015	Ø 15,0 mm	18,5 cm / 7 ¹ / ₄ "
030-240-016	Ø 16,0 mm	18,5 cm / 7 ¹ / ₄ "
030-240-017	Ø 17,0 mm	18,5 cm / 7 ¹ / ₄ "
030-240-018	Ø 18,0 mm	18,5 cm / 7 ¹ / ₄ "
030-240-019	Ø 19,0 mm	18,5 cm / 7 ¹ / ₄ "
030-240-020	Ø 20,0 mm	18,5 cm / 7 ¹ / ₄ "
030-240-021	Ø 21,0 mm	18,5 cm / 7 ¹ / ₄ "
030-240-022	Ø 22,0 mm	18,5 cm / 7 ¹ / ₄ "
030-240-023	Ø 23,0 mm	18,5 cm / 7 ¹ / ₄ "
030-240-024	Ø 24,0 mm	18,5 cm / 7 ¹ / ₄ "
030-240-025	Ø 25,0 mm	18,5 cm / 7 ¹ / ₄ "
030-240-026	Ø 26,0 mm	18,5 cm / 7 ¹ / ₄ "
030-240-027	Ø 27,0 mm	18,5 cm / 7 ¹ / ₄ "
030-240-028	Ø 28,0 mm	18,5 cm / 7 ¹ / ₄ "
030-240-029	Ø 29,0 mm	18,5 cm / 7 ¹ / ₄ "
030-240-030	Ø 30,0 mm	18,5 cm / 7 ¹ / ₄ "

HEGAR

030-241-015	Ø 1,5 mm	18,5 cm / 7 ¹ / ₄ "
030-241-025	Ø 2,5 mm	18,5 cm / 7 ¹ / ₄ "
030-241-035	Ø 3,5 mm	18,5 cm / 7 ¹ / ₄ "
030-241-045	Ø 4,5 mm	18,5 cm / 7 ¹ / ₄ "
030-241-055	Ø 5,5 mm	18,5 cm / 7 ¹ / ₄ "
030-241-065	Ø 6,5 mm	18,5 cm / 7 ¹ / ₄ "
030-241-075	Ø 7,5 mm	18,5 cm / 7 ¹ / ₄ "
030-241-085	Ø 8,5 mm	18,5 cm / 7 ¹ / ₄ "
030-241-095	Ø 9,5 mm	18,5 cm / 7 ¹ / ₄ "
030-241-105	Ø 10,5 mm	18,5 cm / 7 ¹ / ₄ "
030-241-115	Ø 11,5 mm	18,5 cm / 7 ¹ / ₄ "
030-241-125	Ø 12,5 mm	18,5 cm / 7 ¹ / ₄ "
030-241-135	Ø 13,5 mm	18,5 cm / 7 ¹ / ₄ "
030-241-145	Ø 14,5 mm	18,5 cm / 7 ¹ / ₄ "
030-241-155	Ø 15,5 mm	18,5 cm / 7 ¹ / ₄ "
030-241-165	Ø 16,5 mm	18,5 cm / 7 ¹ / ₄ "
030-241-175	Ø 17,5 mm	18,5 cm / 7 ¹ / ₄ "



030

Uterus-Dilatatoren
Uterine Dilators
Dilatadores uterinos
Dilatatori uterini



HEGAR

030-240-140 Ø 4,0 - Ø 17,0 mm

Satz, in Metalletui
Set, in metal case
Juego, en caja metalica
Set, in scatola metallica
(14 dilators)

HEGAR

030-240-260 Ø 1,0 - Ø 26,0 mm

Satz, in Metalletui
Set, in metal case
Juego, en caja metalic
Set, in scatola metallica
(26 dilators)



HEGAR

030-245-140 Ø 4,0 - Ø 17,0 mm

Satz, in Lederetui
Set, in leather pouch
Juego, en estuche de piel
Set, in scatola de pelle
(14 dilators)

HEGAR

030-245-260 Ø 1,0 - Ø 26,0 mm

Satz, in Lederetui
Set, in leather pouch
Juego, en estuche de piel
Set, in scatola de pelle
(26 dilators)



HEGAR

030-250-002	Ø 1,0/ 2,0	mm	20,0 cm / 8"
030-250-004	Ø 3,0/ 4,0	mm	20,0 cm / 8"
030-250-006	Ø 5,0/ 6,0	mm	20,0 cm / 8"
030-250-008	Ø 7,0/ 8,0	mm	20,0 cm / 8"
030-250-010	Ø 9,0/10,0	mm	20,0 cm / 8"
030-250-012	Ø 11,0/12,0	mm	20,0 cm / 8"
030-250-014	Ø 13,0/14,0	mm	20,0 cm / 8"
030-250-016	Ø 15,0/16,0	mm	20,0 cm / 8"
030-250-018	Ø 17,0/18,0	mm	20,0 cm / 8"
030-250-020	Ø 19,0/20,0	mm	20,0 cm / 8"
030-250-022	Ø 21,0/22,0	mm	20,0 cm / 8"
030-250-024	Ø 23,0/24,0	mm	20,0 cm / 8"
030-250-026	Ø 25,0/26,0	mm	20,0 cm / 8"

HEGAR

- 030-250-080** Ø 3,0/4,0-Ø 17,0/18,0 mm (8 dilators)
030-250-130 Ø 1,0/2,0-Ø 25,0/26,0 mm (13 dilators)

Satz ohne auskochbare Stoffrolltasche
 Set without bilable canvas roll
 Juego sin bolsa de tela esterilizable por ebullición
 Set senza busta di tela sterilizzabile

HEGAR

- 030-252-080** Ø 3,0/4,0-Ø 17,0/18,0 mm (8 dilators)
030-252-130 Ø 1,0/2,0-Ø 25,0/26,0 mm (13 dilators)

Satz in auskochbare Stoffrolltasche
 Set in bilable canvas roll
 Juego en bolsa de tela esterilizable por ebullición
 Set in busta di tela sterilizzabile



HEGAR

- 030-254-080** Ø 3,0/4,0-Ø 17,0/18,0 mm

Satz in Metalletui
 Set in metalcase
 Juego en caja metalica
 Set in scatola metallica
 (8 dilators)



030

Uterus-Dilatatoren
Uterine Dilators
Dilatadores uterinos
Dilatatori uterini



HANK

030-260-010	Ø 4,5/ 5,0 mm	Fig. 9/10
030-260-012	Ø 5,5/ 6,0 mm	Fig.11/12
030-260-014	Ø 6,5/ 7,0 mm	Fig.13/14
030-260-016	Ø 7,5/ 8,0 mm	Fig.15/16
030-260-018	Ø 8,5/ 9,0 mm	Fig.17/18
030-260-020	Ø 9,5/10,0 mm	Fig.19/20



HANK

030-260-060 Ø 4,5/5,0-Ø 9,5/10,0 mm (6 dilators)

Satz in auskochbarer Stoffrolltasche

Set in boilable canvas roll

Juego en bolsa de tela esterilizable por ebullición

Set in busta di tela sterilizzabile



PRATT

030-270-005	Ø 4,5/ 5,0 mm	Charr. 13/15
030-270-006	Ø 5,5/ 6,0 mm	Charr. 17/19
030-270-008	Ø 7,5/ 8,0 mm	Charr. 21/23
030-270-009	Ø 8,5/ 9,0 mm	Charr. 25/27
030-270-010	Ø 9,5/10,0 mm	Charr. 29/31
030-270-012	Ø 11,5/12,0 mm	Charr. 33/35
030-270-013	Ø 12,5/13,0 mm	Charr. 37/39
030-270-014	Ø 13,5/14,0 mm	Charr. 41/43

030-270-080 Ø 3,0/4,0-Ø 17,0/18,0 mm (8 dilators)

Satz in auskochbarer Stoffrolltasche

Set in boilable canvas roll

Juego en bolsa de tela esterilizable por ebullición

Set in busta di tela sterilizzabile



030

Uterussonden, Zentimetereinteilung
Uterine Probes, graduated in centimeters
Histerómetros, graduado en centímetros
Isterometri, graduato in cm



biegsam
malleable
maleable
malleabile

SIMS

030-281-320 32,0 cm / 12 1/2"



starr
rigid
rigido
rigido

SIMS

030-283-320 32,0 cm / 12 1/2"



biegsam
malleable
maleable
malleabile

MARTIN

030-285-320 32,0 cm / 12 1/2"



graduiert
graduated
graduado
graduato

COLLIN

030-287-280 28,0 cm / 11"



VALLEIX

030-289-295 25,0 cm / 10"



BRAUN

030-291-280 28,0 cm / 11"



STAUDE-MOORE

030-300-170 17,0 cm / 6³/₄"

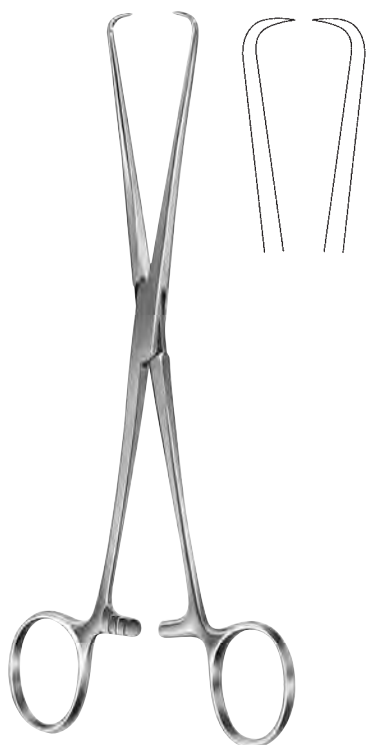

BARRETT

030-304-180 18,0 cm / 7"

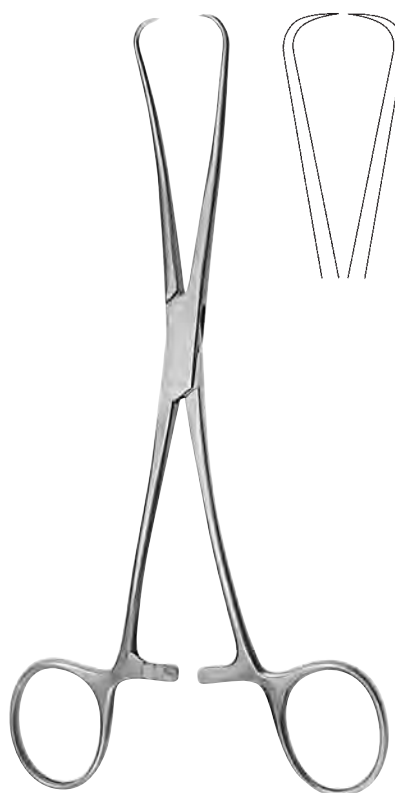

JARCHO

030-307-200 20,0 cm / 8"



030

Hakenzangen
Uterine Tenaculum Forceps
Pinzas para coger el cuello del útero
Pinze per abbassare il collo del` utero



SCHROEDER

030-310-250 25,0 cm / 9³/₄"

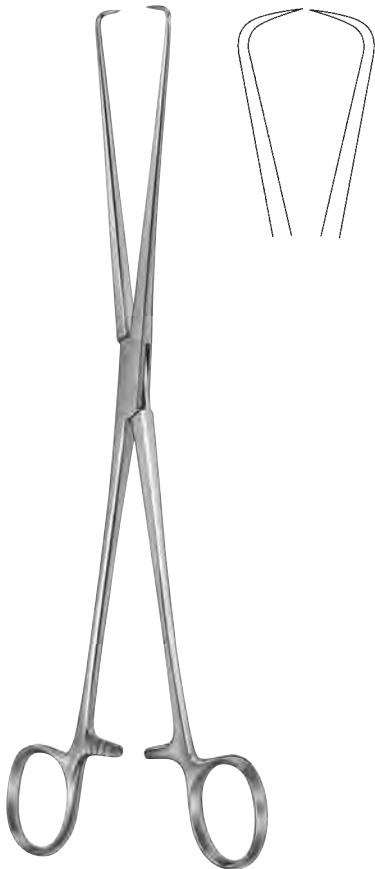

BRAUN

030-312-250 25,0 cm / 9³/₄"

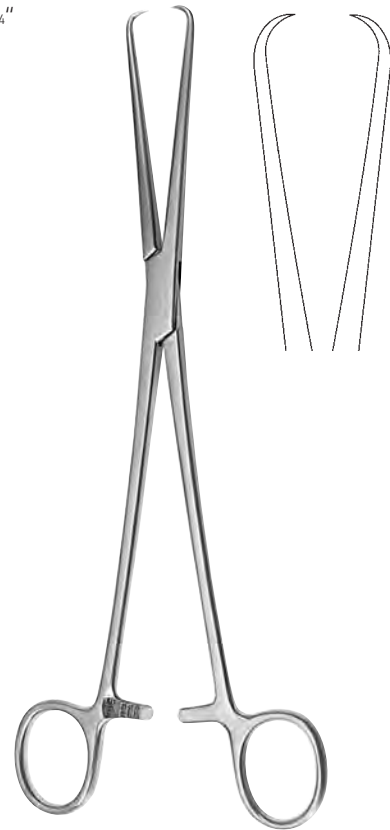

POZZI

030-314-255 25,5 cm / 10¹/₄"

Hakenzangen
 Uterine Tenaculum Forceps
 Pinzas para coger el cuello del útero
 Pinze per abbassare il collo del `utero



030



DUPLAY
030-317-280 28,0 cm / 11"

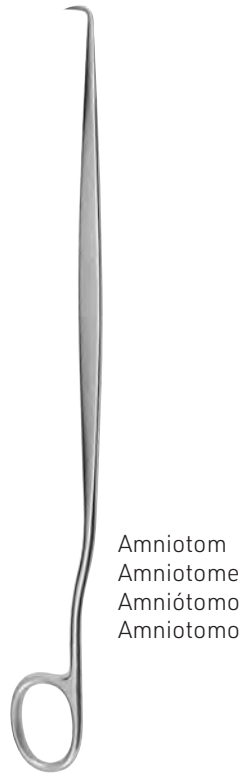

Amniotom
 Amniotome
 Amniótomo
 Amniotomo

BEACHAM
030-320-260 26,0 cm / 10¹/₄"

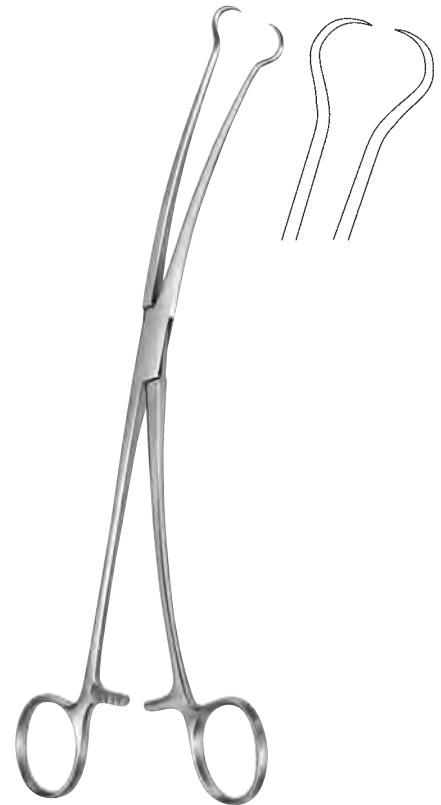

SKENE
030-323-240 24,0 cm / 9¹/₂"



SCHROEDER
030-326-250 25,0 cm / 9³/₄"



SCHROEDER
030-327-250 25,0 cm / 9¹/₂"



3x4 Zähne
 3x4 teeth
 3x4 dientes
 3x4 denti

TEALE
030-329-230 23,0 cm / 9"



030

Hakenzangen
 Uterine Tenaculum Forceps
 Pinzas para coger el cuello del útero
 Pinze per abbassare il collo del` utero



IOWA
 030-331-260 26,0 cm / 10¹/₄"



MUSEUX
 030-340-006 - 030-340-010 24,0 cm / 9¹/₂"

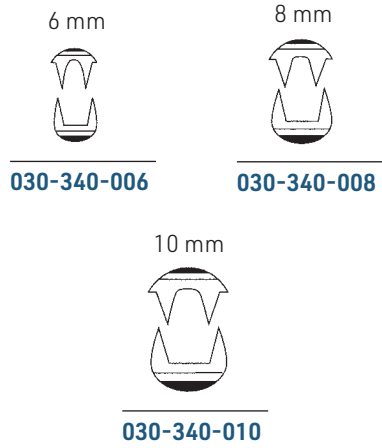

6 mm
 030-341-006

8 mm
 030-341-008

10 mm
 030-341-010

MUSEUX
 030-341-006 - 030-341-010 24,0 cm / 9¹/₂"



JACOBS
 030-344-210 21,0 cm / 8¹/₄"



JACOBS
 030-345-210 21,0 cm / 8¹/₄"

Hakenzangen
Uterine Tenaculum Forceps
Pinzas para coger el cuello del útero
Pinze per abbassare il collo del`utero



030

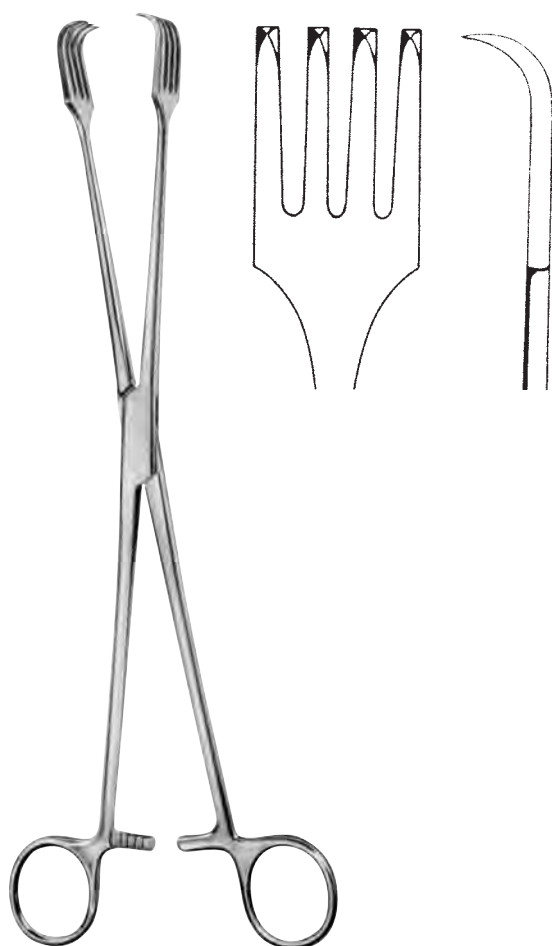

030-350-260 26,0 cm / 10¹/₄"

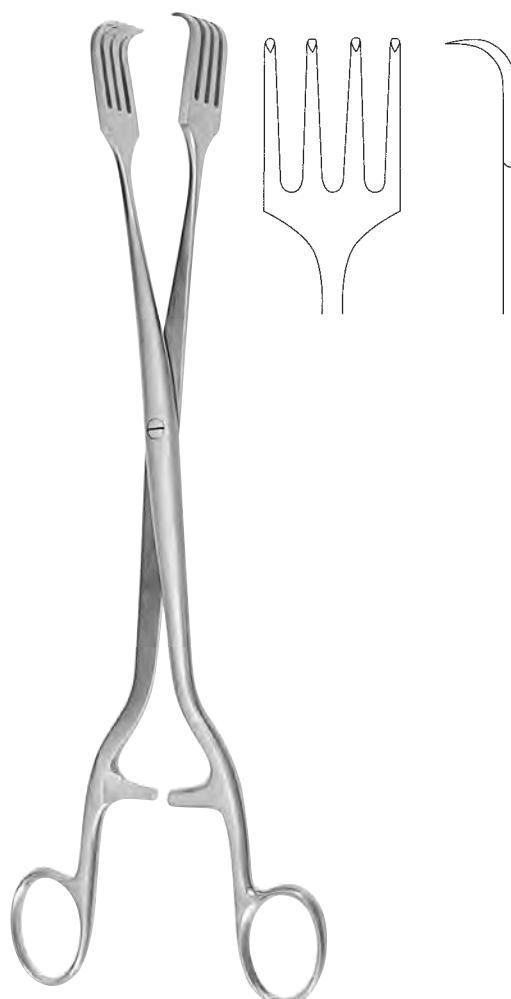

PRATT

030-352-280 28,0 cm / 11"



030

Hakenzangen, Polypen- und Ovarienzangen
Uterine Tenaculum Forceps, Polypus and Ovum Forceps
Pinzas para coger el cuello del útero, Pinzas para pólipos uterinos y ovarios
Pinze per abbassare il collo del` utero, Pinze per polipi e ovaie



BRAUN
030-354-155 15,5 cm / 6"

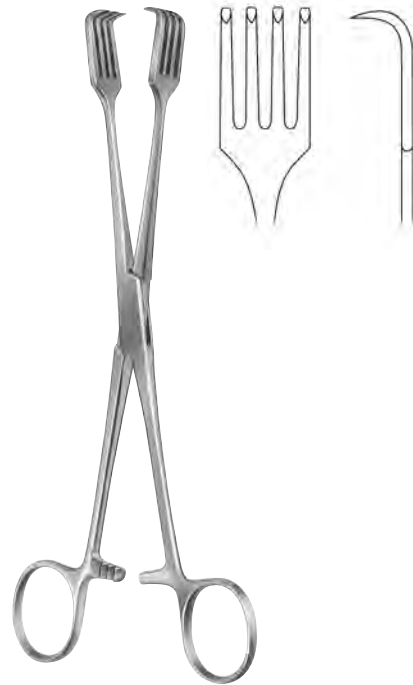

CZERNY
030-356-205 20,5 cm / 8"

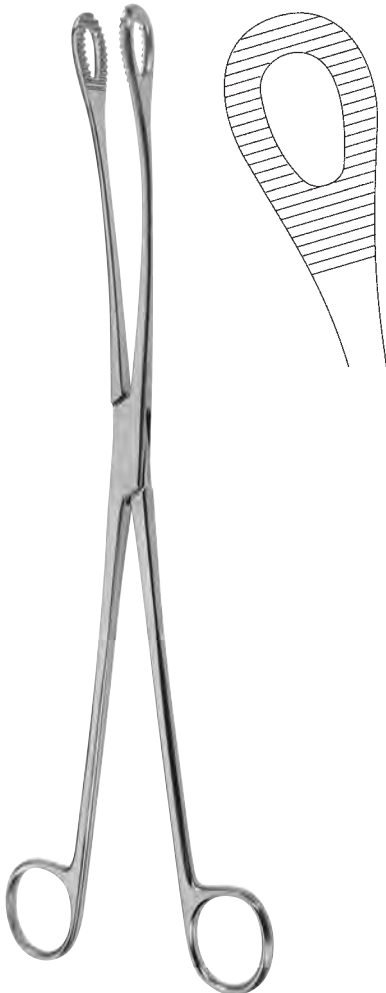

KELLY
030-359-320 32,0 cm / 12¹/₂"



NOTO
030-360-270 27,0 cm / 10⁵/₈"



DOYEN
030-362-200 20,0 cm / 8"

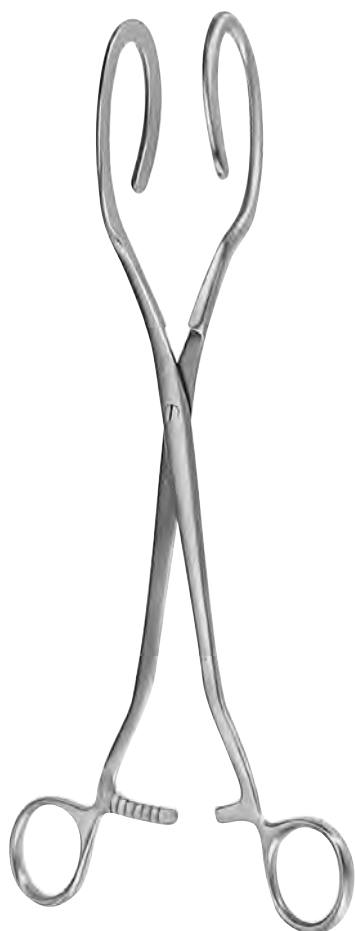

DARTIGUES

030-370-270 27,0 cm / 10³/₄"



SOMER

030-373-230 23,0 cm / 9"



COLLIN

030-376-250 25,0 cm / 9³/₄"



030

Myominstrumente, Fistelhaken
Myoma instruments, Fistula Hooks
Instrumentos para mioma, Ganchos para fistulas
Strumenti per fibroma, Uncini per fistole

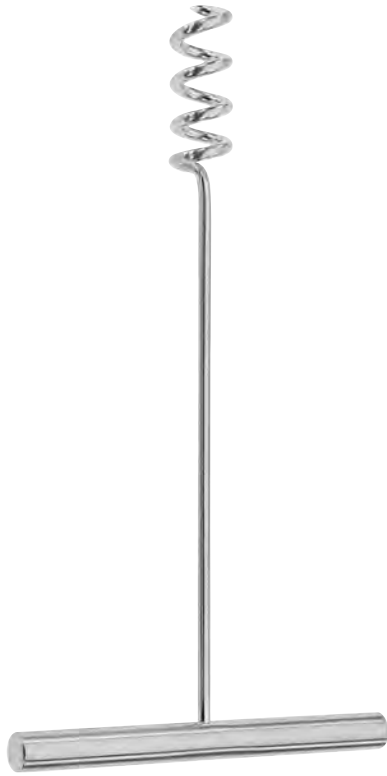

DOYEN
030-380-170 17,0 cm / 6³/₄"



DOYEN
030-382-170 17,0 cm / 6³/₄"



030-384-001



030-384-002



030-384-003



030-384-004



030-384-005

EMMET
030-384-001 - 030-384-005 22,0 cm / 8³/₄"

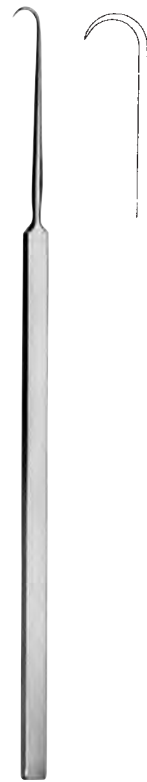

SIMON
030-386-220 22,0 cm / 8³/₄"

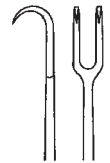

SIMON
030-388-220 22,0 cm / 8³/₄"



KOGAN
 030-391-006 24,0 cm / 9 1/2"



KOGAN
 030-393-006 24,0 cm / 9 1/2"

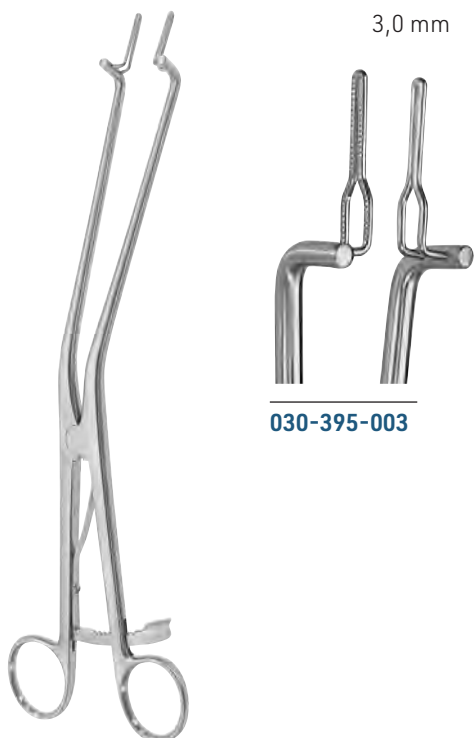

3,0 mm
 030-395-003



4,0 mm
 030-395-004



6,0 mm
 030-395-006

KOGAN
 030-395-003 - 030-395-006 28,0 cm / 11"



030

Endospekula
Endospecula
Endospéculos
Endospecoli



GOODELL

030-397-340 34,0 cm / 13 1/2"

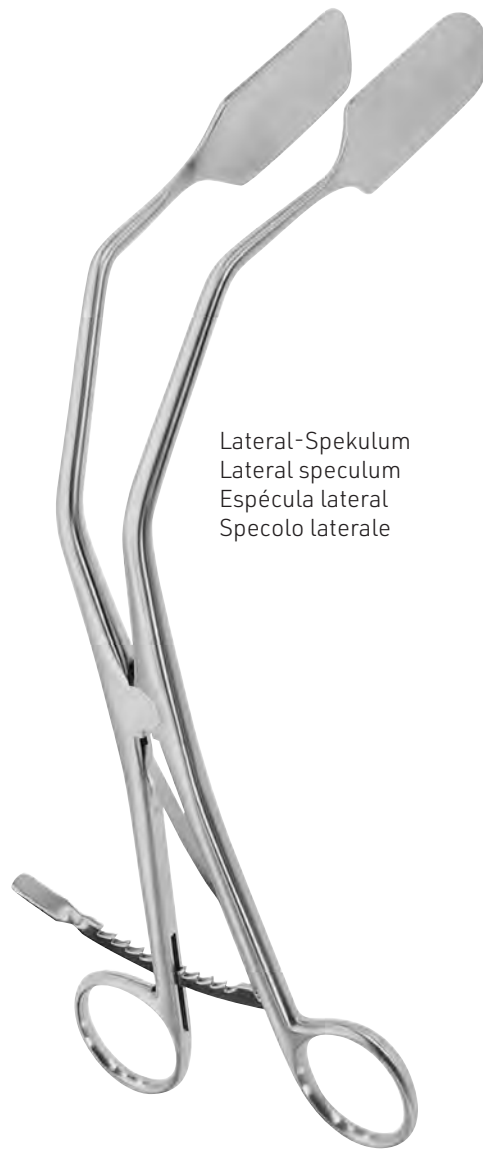

Lateral-Spekulum
Lateral speculum
Espécula lateral
Specolo laterale

030-399-060 60x22 mm 25,0 cm / 10"
030-399-072 72x22 mm 25,0 cm / 10"

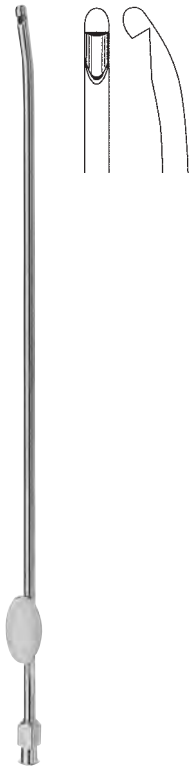

RANDALL

030-451-230 23,0 cm / 9" Ø 4,0 mm

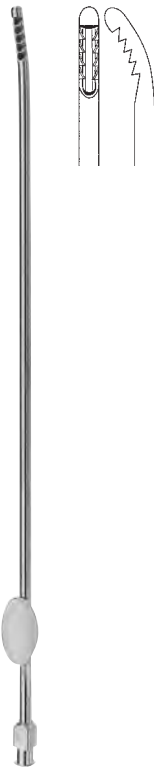

NOVAK

030-453-002 23,0 cm / 9" Ø 2 mm
030-453-004 23,0 cm / 9" Ø 4 mm



KEVORKIAN

030-456-300 30,0 cm / 12"



KEVORKIAN

030-458-300 30,0 cm / 12"



KEVORKIAN

030-460-300 30,0 cm / 12"



030

Probeexzisionszangen
Uterine Biopsy Forceps
Pinzas para biopsia
Pinze per biopsia



GELLHORN

030-501-230 23,0 cm / 9"



FAURE

030-503-210 21,0 cm / 8¹/₄"



SCHUBERT

030-506-210 21,0 cm / 8¹/₄"
030-506-290 29,0 cm / 11¹/₂"

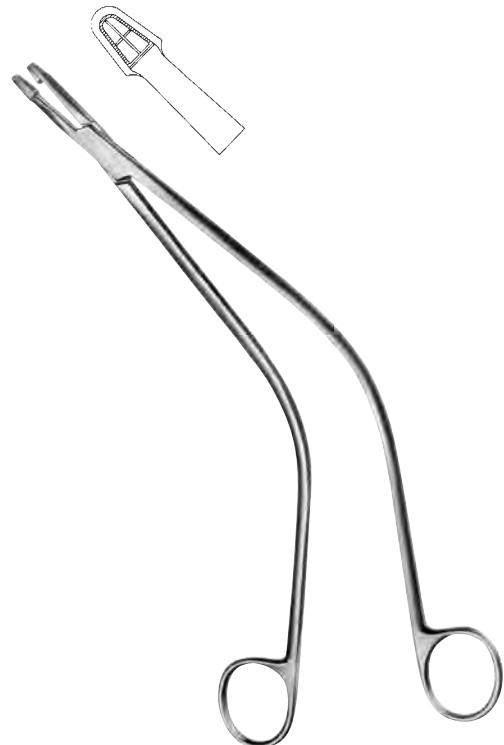

SCHUBERT

030-509-260 26,0 cm / 10¹/₄"



THOMS-GAYLOR

030-511-220 22,0 cm / 8³/₄"
030-511-240 24,0 cm / 9¹/₂"

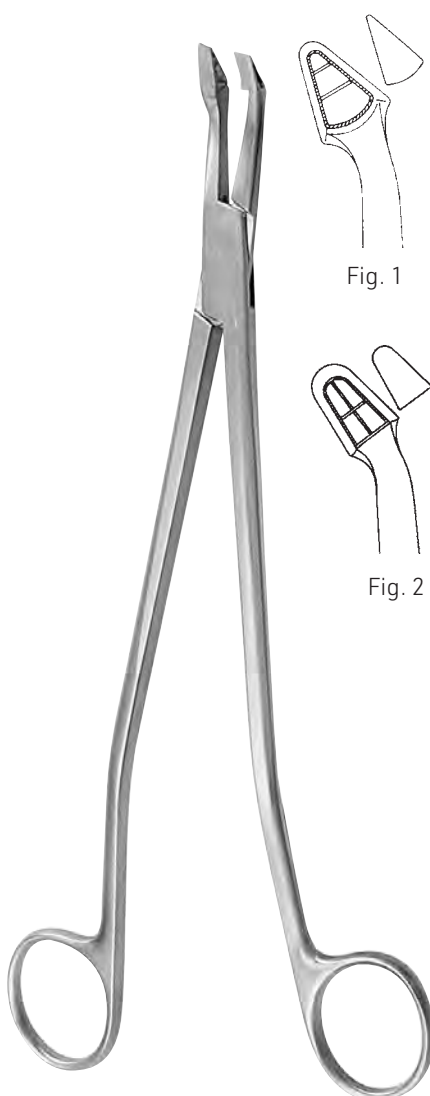

VAN DOREN

030-515-001 25,0 cm / 9³/₄" Fig. 1
030-515-002 25,0 cm / 9³/₄" Fig. 2



VAN DOREN

030-517-002 25,5 cm / 10"



030

Uterus Biopsiezangen
 Cervical Biopsy and Specimen Forceps
 Pinzas saca-bocados para biopsia
 Pinze per la biopsia cervicale e da prelievo

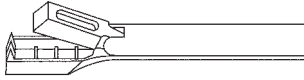
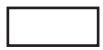
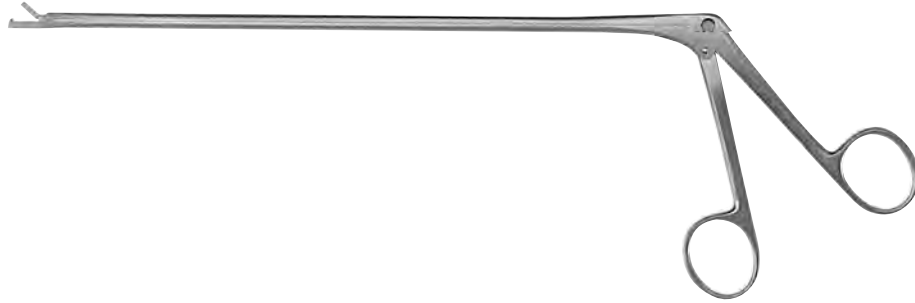

KEVORKIAN

030-520-250 25,0 cm / 10" 3x9 mm

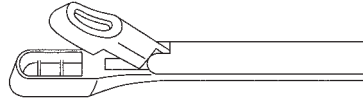

EPPENDORFER

030-524-200 20,0 cm / 8" 4x8 mm



ALEXANDER

030-526-280 28,0 cm / 11"

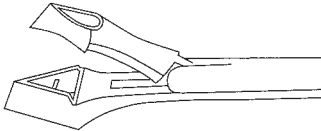

SCHUMACHER

030-530-001 24,0 cm / 9 1/2" 4,5x7 mm

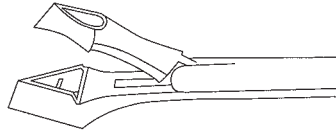

SCHUMACHER

030-530-002 24,0 cm / 9 1/2" 6x9 mm

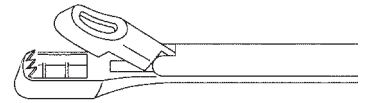

WITTNER

030-532-230 23,0 cm / 9" 4,5x8 mm

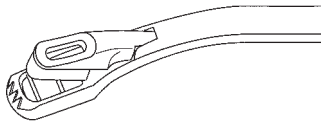

WITTNER

030-533-230 23,0 cm / 9" 4,5x8 mm

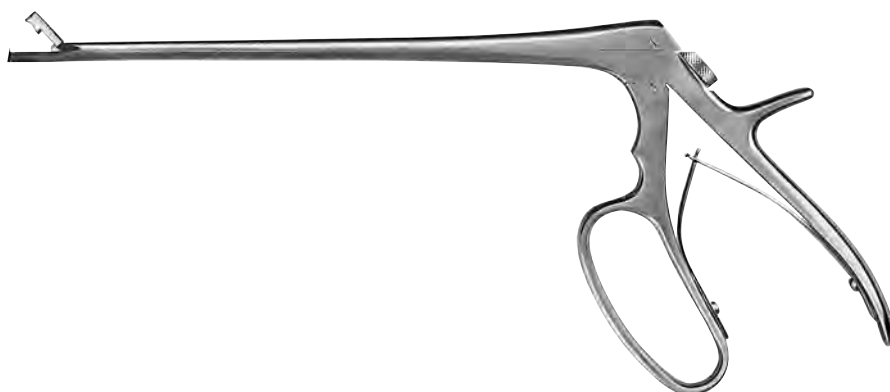

TISCHLER-MORGAN

030-550-210 21,0 cm / 8¹/₄" 7x3 mm
030-550-250 25,0 cm / 9³/₄" 7x3 mm



MINI-TOWNSEND

030-552-210 21,0 cm / 8¹/₄" 2,3x5 mm



BABY-TISCHLER

030-554-210 21,0 cm / 8¹/₄" 2,3x5 mm



TISCHLER-KEVORKIAN

030-556-210 21,0 cm / 8¹/₄" 3x9 mm



KEVORKIAN-PACIFIC

030-558-210 21,0 cm / 8¹/₄" 3x8 mm

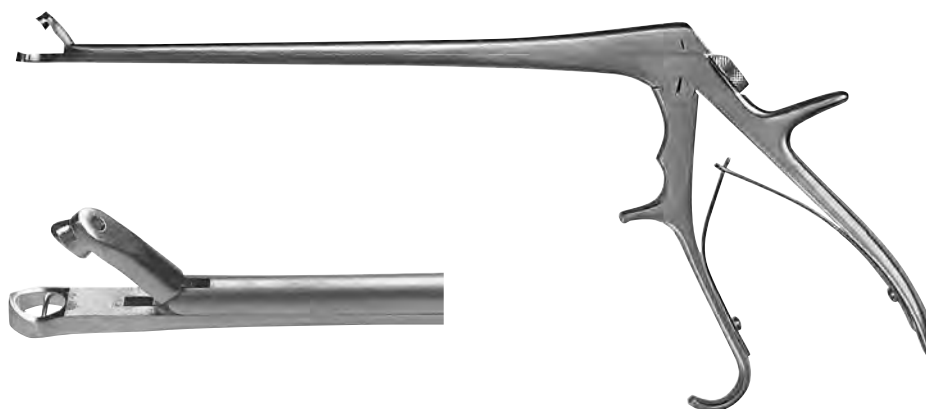

BURKE

030-560-210 21,0 cm / 8¹/₄" 7x5 mm



030

Biopsiezangen
 Biopsy Specimen Forceps
 Pinzas sacabocado para biopsia
 Pinze per biopsia



030-572-000

Griff allein
handle only
manico solo
mango suelto

Aufsätze allein
Tips only
Puntas sueltas
Punti solo

030-570-001 Fig.1
030-570-003 Fig.3
030-570-004 Fig.4
030-570-005 Fig.5
 komplett
 complete
 completo
 completo



TISCHLER MORGAN
030-571-001 Fig.1



TOWNSEND
030-571-003 Fig.3



KEVORKIAN
030-571-004 Fig.4



**MINI-TOWNSEND
(BABY-TISCHLER)**
030-571-005 Fig.5



flexibler Schaft
 felxible shaft
 vastago flexible
 asta flessibile

SERPENTINE

030-580-220 22,0 cm / 8³/₄"
030-580-285 28,5 cm / 11¹/₄"



SCHUMACHER

030-586-001

Aufsatz allein
 Tip only
 Punta suelta
 Punta, sola

SCHUMACHER

030-586-000 25,0 cm / 9³/₄"
 komplett
 complete
 completo
 completo



030

Uteruslöffel
Uterine Scoopes
Cucharillas uterinas
Curette uterine



scharf, fest
sharp, rigid
cortante, rigido
tagliente, rigido



030-600-001

Fig.1



030-600-002

Fig.2



030-600-003

Fig.3

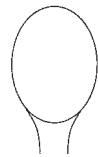

030-600-004

Fig.4

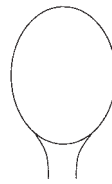

030-600-005

Fig.5

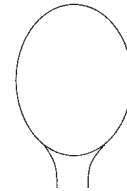

030-600-006

Fig.6

SIMON

030-600-001 - 030-600-006 25,0 cm / 9³/₄"



scharf, fest
sharp, rigid
cortante, rigido
tagliente, rigido



030-602-001

Fig.1



030-602-002

Fig.2



030-602-003

Fig.3



030-602-004

Fig.4



030-602-005

Fig.5

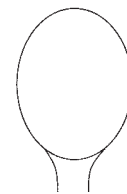

030-602-006

Fig.6

SCHROEDER

030-602-001 - 030-602-006 30,0 cm / 11³/₄"

scharf, fest
 sharp, rigid
 cortante, rigido
 tagliente, rigido

scharf, biegsam
 sharp, malleable
 cortante, maleabile
 tagliente, malleabile

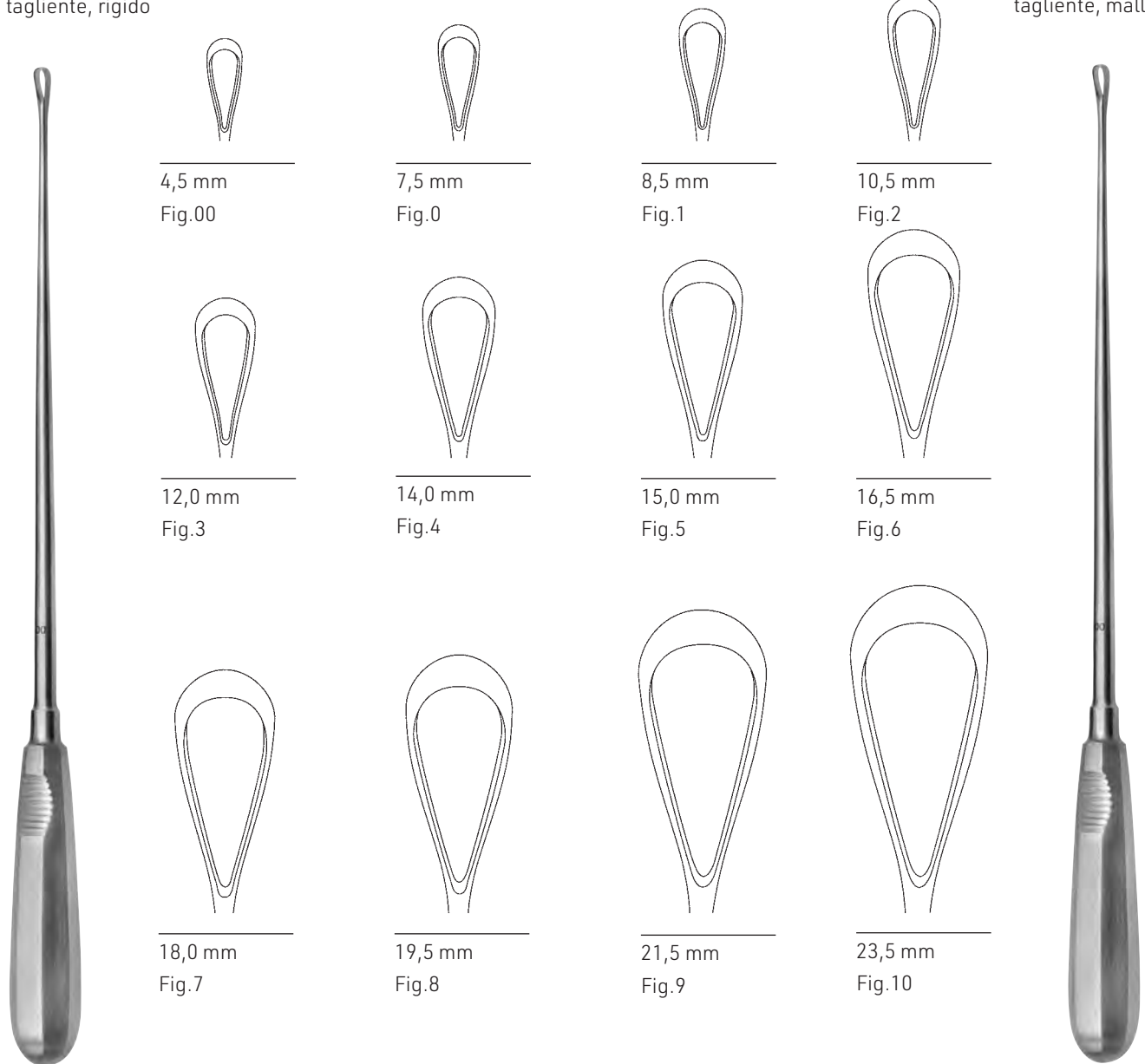

RECAMIER

030-650-045	Fig.00	31,0 cm / 12 ¹ / ₄ "
030-650-075	Fig.0	31,0 cm / 12 ¹ / ₄ "
030-650-085	Fig.1	31,0 cm / 12 ¹ / ₄ "
030-650-105	Fig.2	31,0 cm / 12 ¹ / ₄ "
030-650-120	Fig.3	31,0 cm / 12 ¹ / ₄ "
030-650-140	Fig.4	31,0 cm / 12 ¹ / ₄ "
030-650-150	Fig.5	31,0 cm / 12 ¹ / ₄ "
030-650-165	Fig.6	31,0 cm / 12 ¹ / ₄ "
030-650-180	Fig.7	31,0 cm / 12 ¹ / ₄ "
030-650-195	Fig.8	31,0 cm / 12 ¹ / ₄ "
030-650-215	Fig.9	31,0 cm / 12 ¹ / ₄ "
030-650-235	Fig.10	31,0 cm / 12 ¹ / ₄ "

RECAMIER

030-652-085	Fig.1	31,0 cm / 12 ¹ / ₄ "
030-652-105	Fig.2	31,0 cm / 12 ¹ / ₄ "
030-652-120	Fig.3	31,0 cm / 12 ¹ / ₄ "
030-652-140	Fig.4	31,0 cm / 12 ¹ / ₄ "
030-652-150	Fig.5	31,0 cm / 12 ¹ / ₄ "
030-652-165	Fig.6	31,0 cm / 12 ¹ / ₄ "
030-652-180	Fig.7	31,0 cm / 12 ¹ / ₄ "
030-652-195	Fig.8	31,0 cm / 12 ¹ / ₄ "



030

Uterusküretten
Uterine Curettes
Curetas uterinas
Curette uterine

stumpf, fest
blunt, rigid
romo, rigida
smusso, rigido



4,5 mm
Fig.00



7,5 mm
Fig.0



8,5 mm
Fig.1



10,5 mm
Fig.2



12,0 mm
Fig.3



14,0 mm
Fig.4



15,0 mm
Fig.5



16,5 mm
Fig.6



18,0 mm
Fig.7

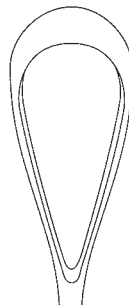

19,5 mm
Fig.8

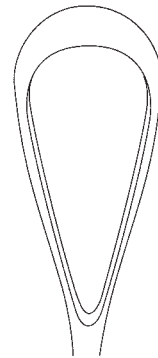

21,5 mm
Fig.9

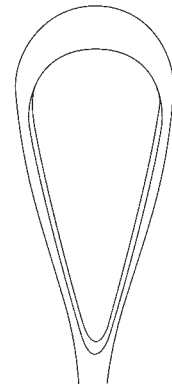

23,5 mm
Fig.10

RECAMIER

030-654-045	Fig.00	31,0 cm / 12 ¹ / ₄ "
030-654-075	Fig.0	31,0 cm / 12 ¹ / ₄ "
030-654-085	Fig.1	31,0 cm / 12 ¹ / ₄ "
030-654-105	Fig.2	31,0 cm / 12 ¹ / ₄ "
030-654-120	Fig.3	31,0 cm / 12 ¹ / ₄ "
030-654-140	Fig.4	31,0 cm / 12 ¹ / ₄ "
030-654-150	Fig.5	31,0 cm / 12 ¹ / ₄ "
030-654-165	Fig.6	31,0 cm / 12 ¹ / ₄ "
030-654-180	Fig.7	31,0 cm / 12 ¹ / ₄ "
030-654-195	Fig.8	31,0 cm / 12 ¹ / ₄ "
030-654-215	Fig.9	31,0 cm / 12 ¹ / ₄ "
030-654-235	Fig.10	31,0 cm / 12 ¹ / ₄ "

scharf, fest
 sharp, rigid
 cortante, rigido
 tagliente, rigido

scharf, biegsam
 sharp, malleable
 cortante, maleable
 tagliente, malleable

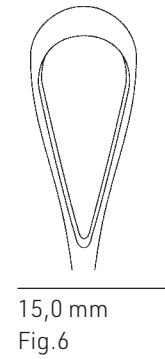
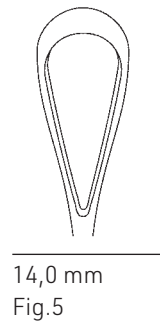
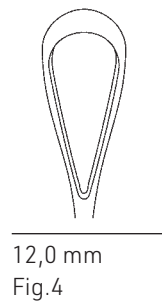
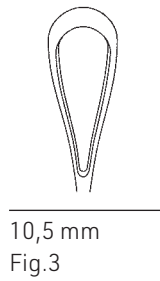
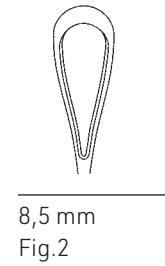
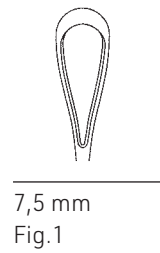
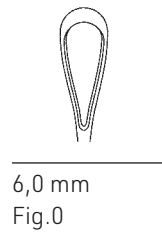
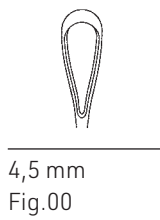

SIMS

030-660-045	Fig.00	28,0 cm / 11"
030-660-060	Fig.0	28,0 cm / 11"
030-660-075	Fig.1	28,0 cm / 11"
030-660-085	Fig.2	28,0 cm / 11"
030-660-105	Fig.3	28,0 cm / 11"
030-660-120	Fig.4	28,0 cm / 11"
030-660-140	Fig.5	28,0 cm / 11"
030-660-150	Fig.6	28,0 cm / 11"

SIMS

030-662-075	Fig.1	28,0 cm / 11"
030-662-085	Fig.2	28,0 cm / 11"
030-662-105	Fig.3	28,0 cm / 11"
030-662-120	Fig.4	28,0 cm / 11"
030-662-140	Fig.5	28,0 cm / 11"
030-662-150	Fig.6	28,0 cm / 11"



030

Uterusküretten
Uterine Curettes
Curetas uterinas
Curette uterine

stumpf, fest
blunt, rigid
romo, rigida
smusso, rigido



4,5 mm
Fig.00



6,0 mm
Fig.0



7,5 mm
Fig.1



8,5 mm
Fig.2



10,5 mm
Fig.3



12,0 mm
Fig.4



14,0 mm
Fig.5



15,0 mm
Fig.6

SIMS

030-664-045	Fig.00	28,0 cm / 11"
030-664-060	Fig.0	28,0 cm / 11"
030-664-075	Fig.1	28,0 cm / 11"
030-664-085	Fig.2	28,0 cm / 11"
030-664-105	Fig.3	28,0 cm / 11"
030-664-120	Fig.4	28,0 cm / 11"
030-664-140	Fig.5	28,0 cm / 11"
030-664-150	Fig.6	28,0 cm / 11"

stumpf, fest
 blunt, rigid
 romo, rigida
 smusso, rigido

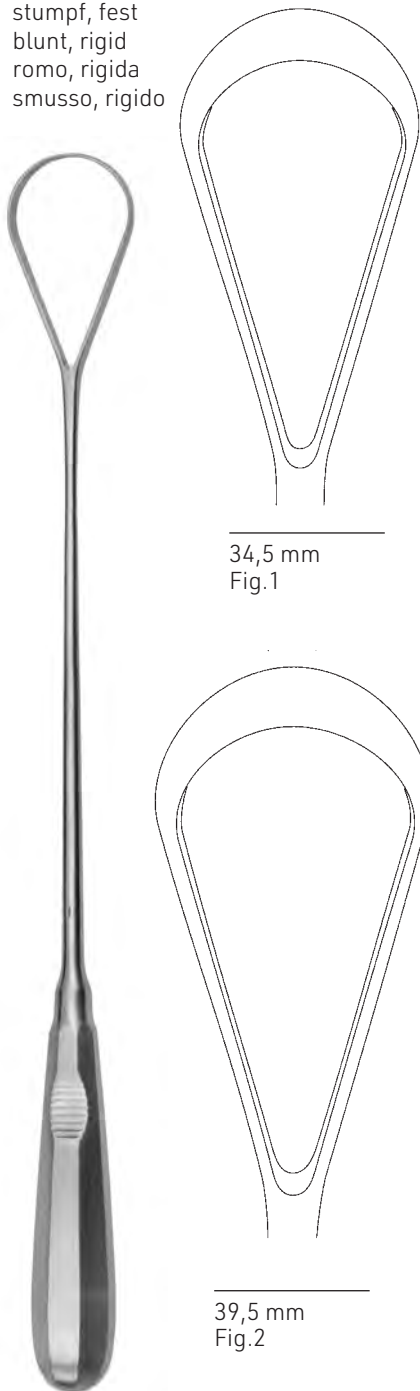

34,5 mm
 Fig.1

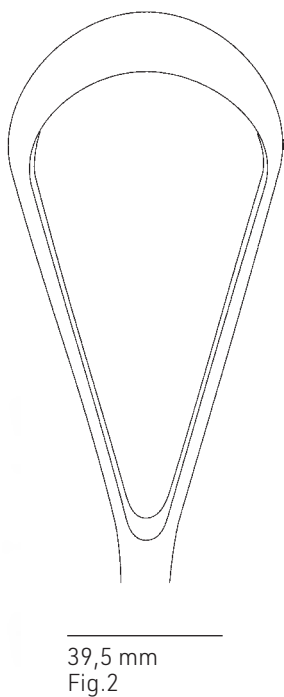

39,5 mm
 Fig.2

RECAMIER

030-674-345 36,0 cm / 14¹/₄" Fig.1
030-674-395 36,0 cm / 14¹/₄" Fig.2

scharf, biegsam
 sharp, malleable
 cortante, maleable
 tagliente, malleabile

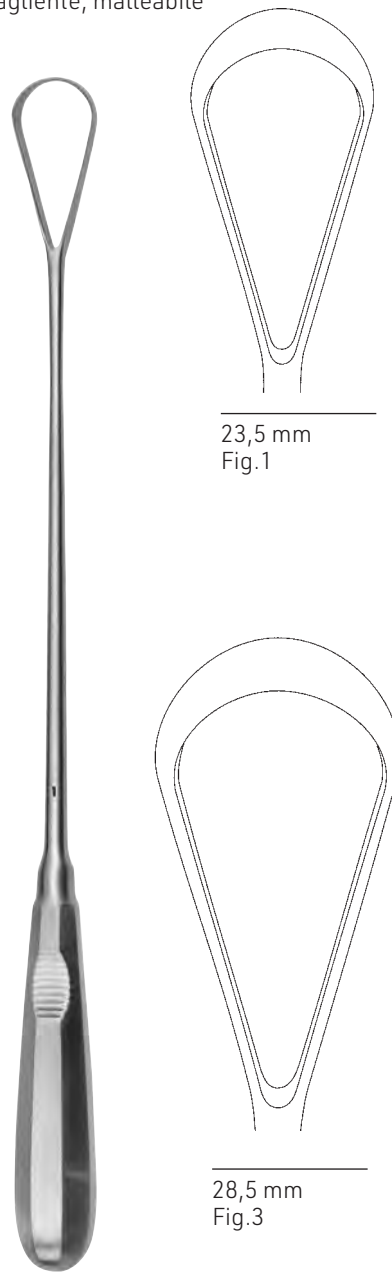

23,5 mm
 Fig.1

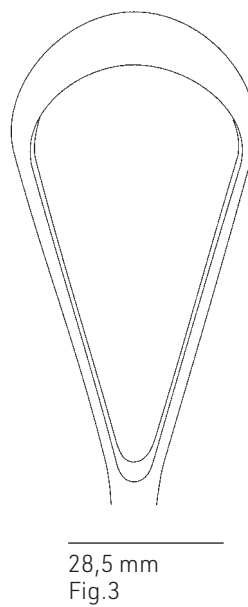

28,5 mm
 Fig.3

BUMM

030-682-235 31,0 cm / 12¹/₄" Fig.1
030-682-285 31,0 cm / 12¹/₄" Fig.3

stumpf, biegsam
 blunt, malleable
 romo, maleable
 smusso, malleabile

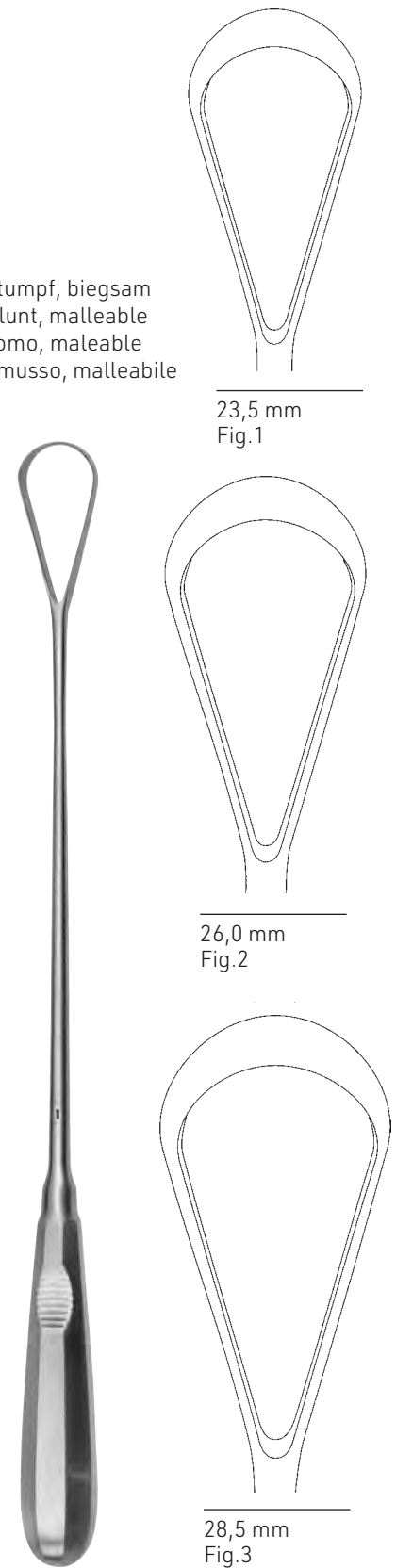

23,5 mm
 Fig.1

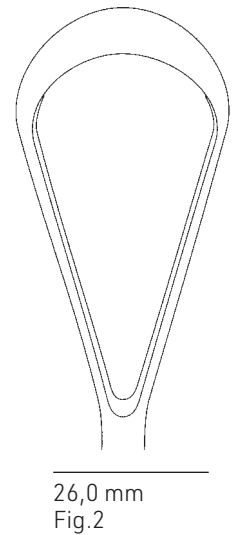

26,0 mm
 Fig.2

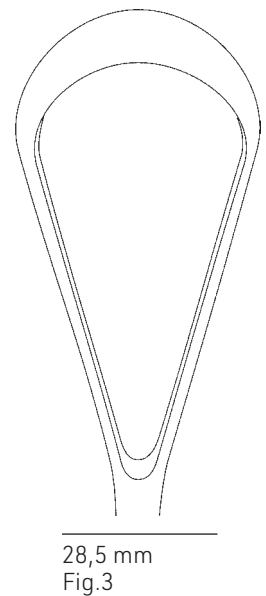

28,5 mm
 Fig.3

BUMM

030-686-235 31,0 cm / 12¹/₄" Fig.1
030-686-260 31,0 cm / 12¹/₄" Fig.2
030-686-285 31,0 cm / 12¹/₄" Fig.3



030

Uteruslöffel
Uterine Scoopes
Curetas uterinas
Curette uterine

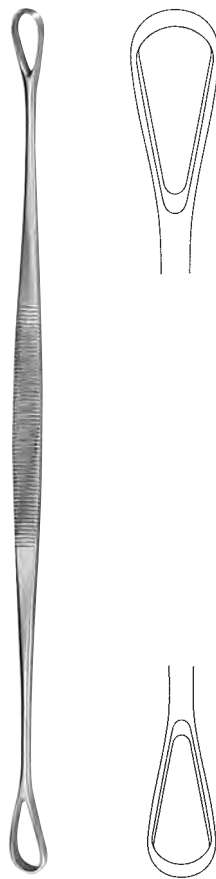

scharf/stumpf
sharp/blunt
cortante/romo
tagliente/smusso

BLAKE

030-697-270 27,0 cm / 10³/₄"



030-701-003 Ø 3,0 mm

030-701-004 Ø 4,5 mm

030-701-006 Ø 6,0 mm

030-701-008 Ø 8,0 mm

030-701-010 Ø 10,0 mm

030-701-012 Ø 12,0 mm

030-701-014 Ø 14,0 mm

030-701-120 12,0 cm, 4³/₄"

Kupplungsstück
Coupling Piece
Pieza de acoplamiento
Pezzo di collegamento

030-701-200

Dichtungsring (Paar) für Kupplungsstück
Gasket rings (pair) for coupling piece
Anillos de cierre (par) para pieza de acoplamiento
Anelli di tenuta (paio) per pezzo di collegamento

030-701-003 - 030-701-014 29,0 cm / 11¹/₂"



030

Salpingograph
Salpingograph
Salpingógrafo
Salpingógrafo



SCHULTZE
030-710-000

Komplett im Holzetui
Complete in wooden case
Completo en estuche de madera
Completo in scatola di legno



SCHULTZE
030-710-001



DRUCK
030-710-002

Manometer allein
Manometer only
Manometro solo
Manometro solo



MARTIN

030-900-340 34,0 cm / 13³/₈"

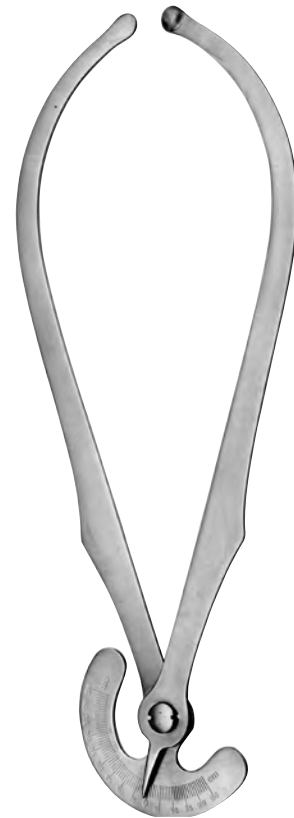

COLLIN

030-902-350 35,0 cm / 13³/₄"



COLLYER

030-904-300 30,0 cm / 13³/₄"



030

Geburtszangen
Obstetrical Forceps
Fórceps para obstétrica
Forcipi per ostetricia



WRIGLEY

030-911-280 28,0 cm / 11"



SIMPSON

030-913-230 23,0 cm / 9"
030-913-300 30,0 cm / 11³/₄"



SIMPSON-BRAUN

030-915-360 36,0 cm / 14¹/₈"



DE LEE

030-917-360 36,0 cm / 14¹/₄"



MCLEAN-TUCKER

030-919-390 39,0 cm / 15¹/₂"

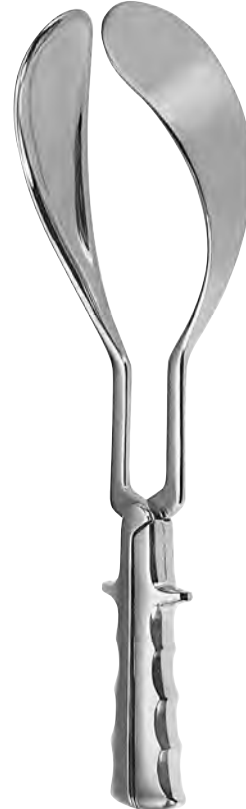

MCLEAN-LUIKART

030-921-390 39,0 cm / 15¹/₂"



NAEGELE

030-923-360 36,0 cm / 14¹/₄"
030-923-400 40,0 cm / 16"



KIELLAND

030-925-410 41,0 cm / 16¹/₂"

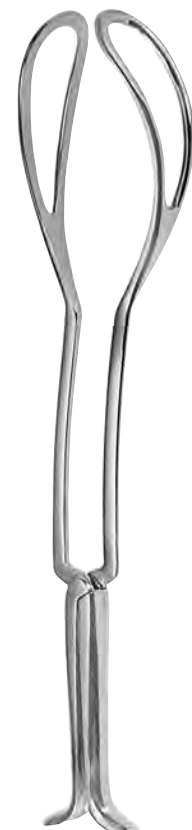

PIPER

030-927-440 44,0 cm / 17¹/₄"



030

Abortuszangen
Placenta and Ovum Forceps
Pinzas para aborto
Pinze per placenta e per ovaie



SELLHEIM

030-939-280 28,0 cm / 11"



GREEN-ARMYTAGE

030-940-210 21,0 cm / 8¹/₄"

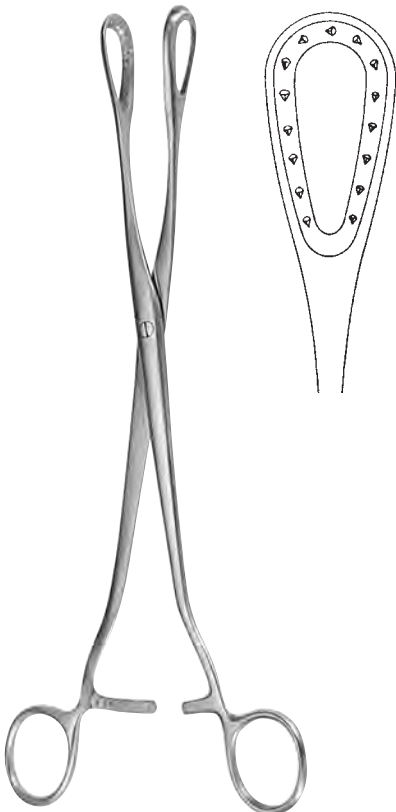

SAENGER

030-942-270 27,0 cm / 10³/₄"

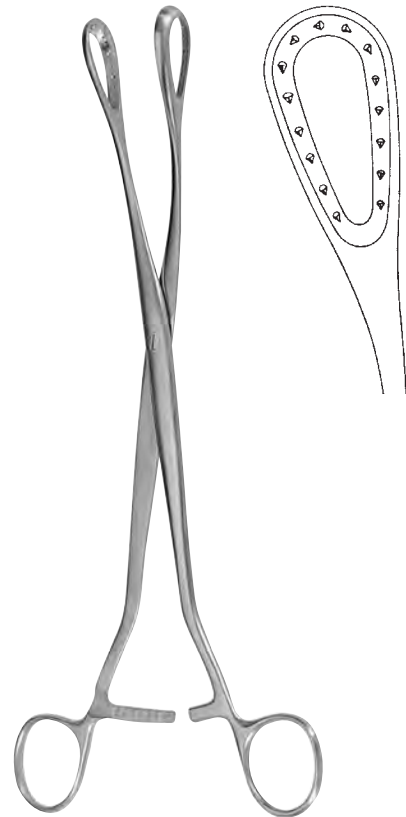

SAENGER

030-943-270 27,0 cm / 10³/₄"

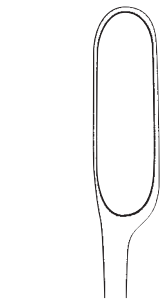
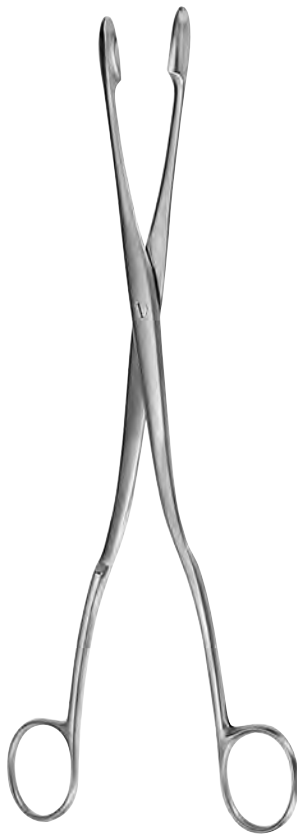

030-950-001 Fig.1

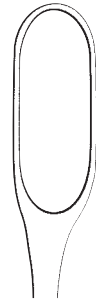

030-950-002 Fig.2

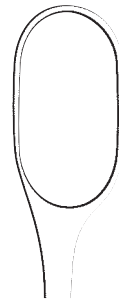

030-950-003 Fig.3



030-951-001 Fig.1



030-951-002 Fig.2

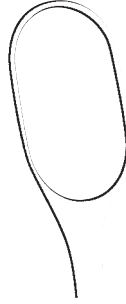

030-951-003 Fig.3

WINTER

030-950-001 - 030-951-003 28,0 cm / 11"



030-955-002 Fig.2



030-955-003 Fig.3

WINTER

030-955-002 - 030-955-003 28,0 cm / 11"



14 mm



Fig.1

030-961-001

18 mm



Fig. 2

030-961-002

20 mm



Fig. 3

030-961-003

stumpf, Rückseite gerieft
 blunt, backside serrated
 romo, dorso estriado
 smusso, dorso scanalato

CUZZI

030-961-001 - 030-961-003 30,0 cm / 11³/₄"



030

Abortuslöffel, Nabelschnurklemmen
Placenta scoops, Umbilical cord clamps
Cucharillas para aborto, Clamps umbilicales
Cucchiai per placenta e ovaie, Clamps ombelicali

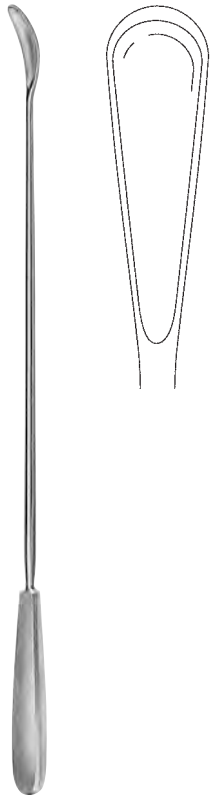

WALLICH

030-963-420 42,0 cm / 17"

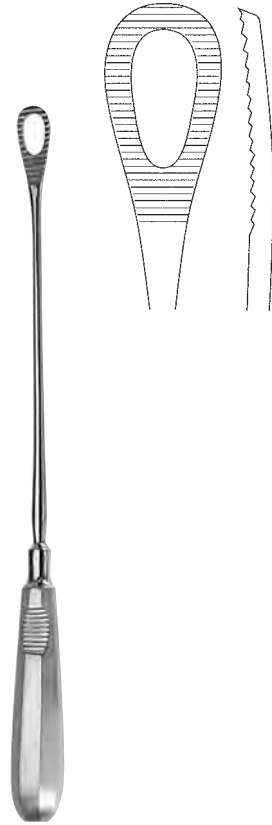

PESTALOZZA

030-965-300 30,0 cm / 11³/₄"

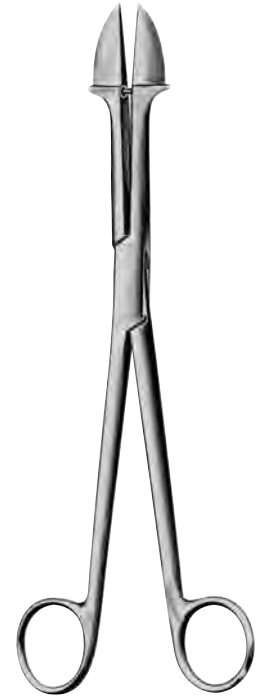

SPELLIE

030-970-250 25,0 cm / 10"



BRAUN

030-971-300 30,0 cm / 11³/₄"



COLLIN

030-975-090 9,0 cm / 3¹/₂"



KANE

030-977-085 8,5 cm / 3¹/₄"



BRAUN

030-981-420 42,0 cm / 16½"

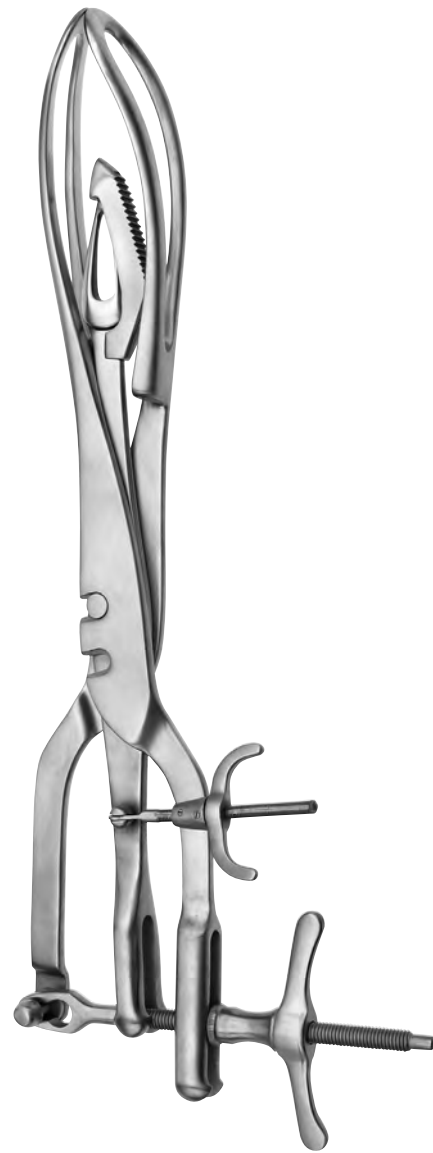

TARNIER

030-983-460 46,0 cm / 18"



030



032

Ophthalmologie
Ophthalmology
Oftalmología
Ophtalmologia



032

Tonometer, Sperrelevatoren
Tonometer, Eye Specula
Tonómetros, Blefarostatos
Tonometri, Blefarostati

ungeeicht
un calibrated
no calibrado
non calibrato



SCHIOETZ

032-010-000

mit gerader Skala
with straight scale
con escala recta
con scala retta

032-011-000

mit gebogener Skala
with curved scale
con escala inclinada
con scala inclinata



BARRAQUER (COLIBRI)

032-021-003 3,0 cm / 1 1/4"

für Kinder
for children
para niños
per bambini

BARRAQUER (COLIBRI)

032-021-004 4,0 cm / 1 1/2"

für Erwachsene
for adults
para adultos
per adulti



BOWMAN

032-023-007 7,0 cm / 2 3/4"

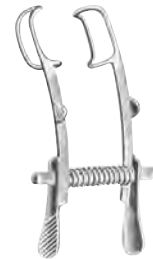

MELLINGER

032-051-005 5,0 cm / 2"

für Kinder
for children
para niños
per bambin

MELLINGER

032-051-007 7,0 cm / 2 3/4"

für Erwachsene
for adults
para adultos
per adulti



MELLINGER-AXENFELD

032-053-007 7,0 cm / 2 3/4"



MELLINGER-AXENFELD

032-055-007 7,0 cm / 2 3/4"



CASTROVIEJO

032-059-008 8,0 cm / 3 1/8"

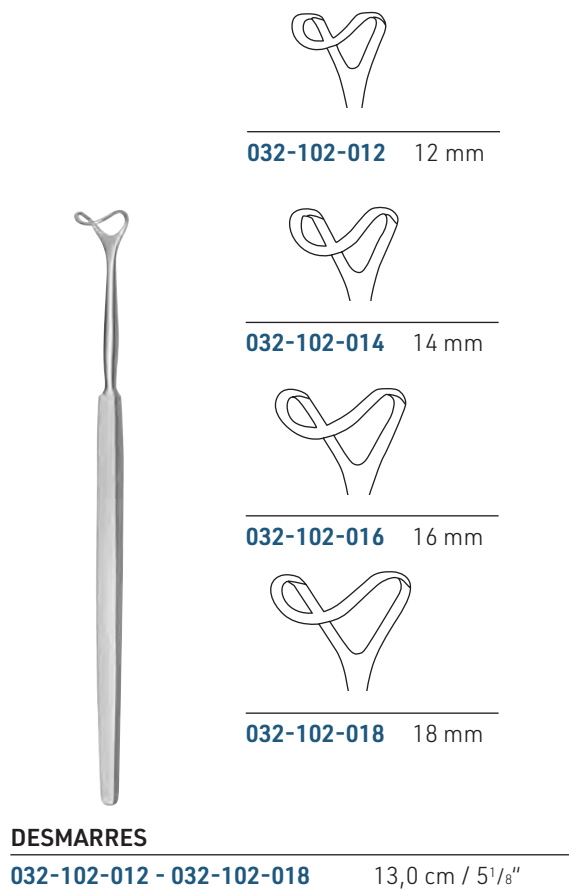
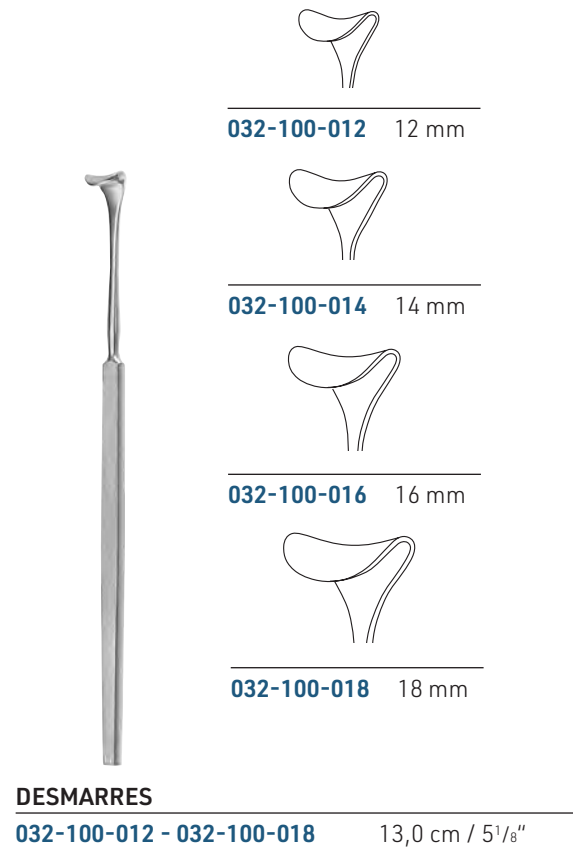
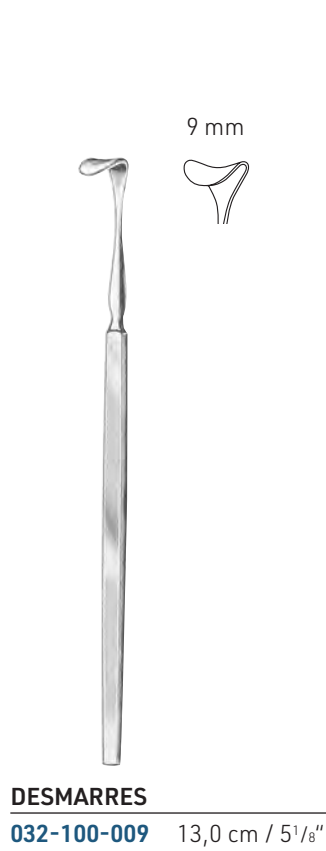



032

Starmesser
Cataract Knives
Cuchillos para catarata
Coltelli per cataratta



FIG.0
032-120-000



FIG.1
032-120-001



FIG.2
032-120-002



FIG.3
032-120-003

GRAEFE

032-120-000 - 032-120-003 13,0 cm / 5 1/8"



FIG.1
032-150-001



FIG.2
032-150-002

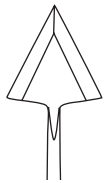

FIG.3
032-150-003



JAEGER-GRIESHABER

032-150-001 - 032-150-003



032-160-001



032-160-002



032-160-003



KNAPP

032-160-001 - 032-160-003

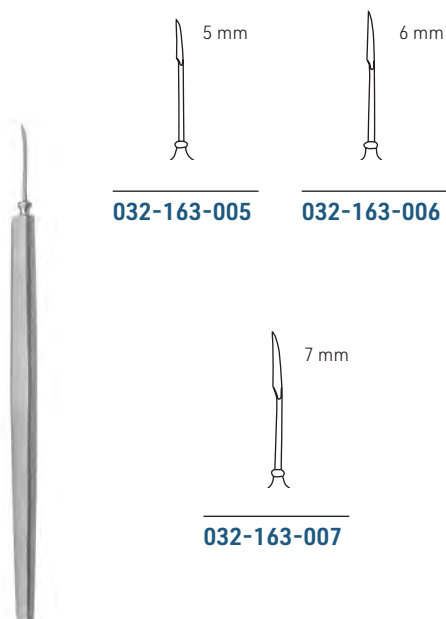

032-163-005

032-163-006

032-163-007

ZIEGLER

032-163-005 - 032-163-007 13,0 cm / 5 1/8"

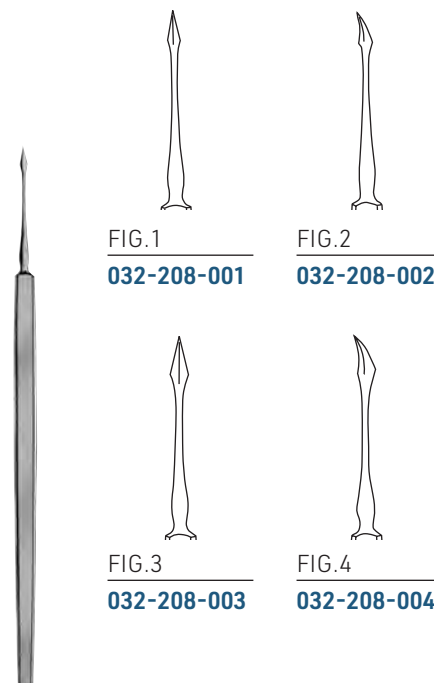

FIG.1

032-208-001

FIG.2

032-208-002

FIG.3

032-208-003

FIG.4

032-208-004

032-208-001 - 032-208-004 13,0 cm / 5 1/8"

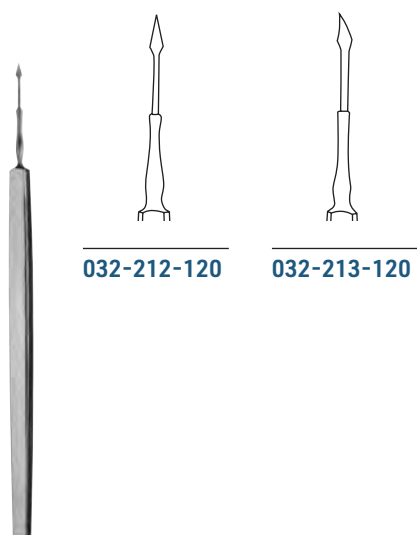

032-212-120

032-213-120

BOWMAN

032-212-120 - 032-213-120 12,0 cm / 4 3/4"

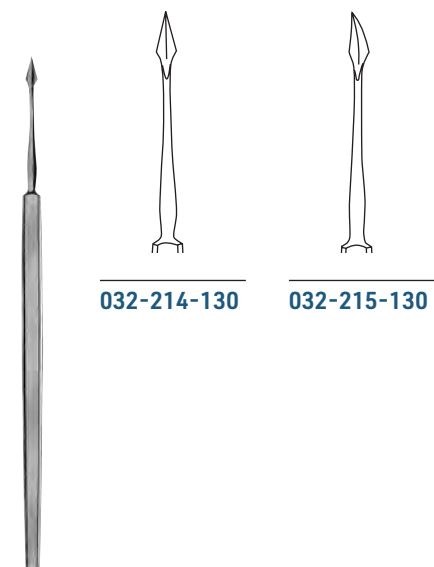

032-214-130

032-215-130

032-214-130 - 032-215-130 13,0 cm / 5 1/8"



032

Fremdkörper-Instrumente, Cystotome
 Foreign Body Instruments, Cystotomes
 Instrumentos para cuerpos extraños, Quistótomos
 Strumenti per corpi estranei, Cistitome



WALTON
 032-232-120



WALTON
 032-234-120



MEYER
 032-236-120

032-232-120 - 032-236-120 12,0 cm / 4³/₄"



STANDARD
 032-244-120

Fremdkörperschlinge und Magnet
 in Umsteckhülse

Foreign Body Remover and Magnetic
 Eye Probe, in reversible handle

Lazo para cuerpos extraños e Imàn,
 en mango reversible

Laccio per corpi estranei e Calamita,
 in manico reversibile



032-246-130

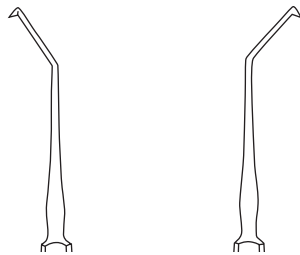

032-247-130



032-249-130

GRAEFE
 032-246-130 - 032-249-130 13,0 cm / 5¹/₈"

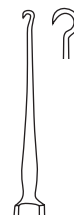

032-253-120

scharf
 shap
 agudo
 acuto

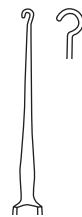

032-255-120

stumpf
 blunt
 romo
 smusso

GRAEFE
 032-253-120 - 032-255-120 12,0 cm / 4³/₄"

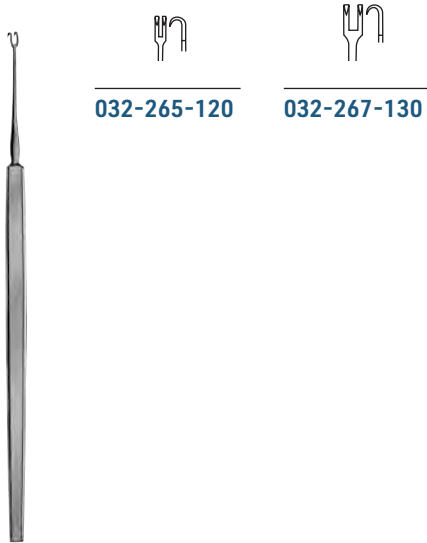

032-265-120

032-267-130

GUTHRIE

032-265-120 12,0 cm / 4³/₄"
032-267-130 13,0 cm / 5¹/₈"

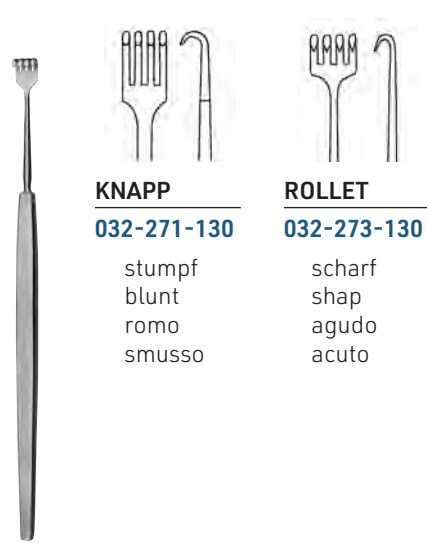

KNAPP
032-271-130

stumpf
 blunt
 romo
 smusso

ROLLET
032-273-130

scharf
 shap
 agudo
 acuto

032-271-130 - 032-273-130 13,0 cm / 5¹/₈"

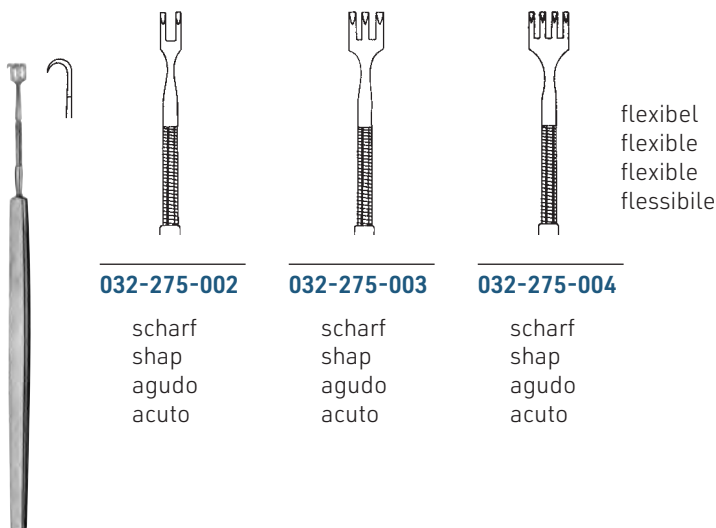

032-275-002

scharf
 shap
 agudo
 acuto

032-275-003

scharf
 shap
 agudo
 acuto

032-275-004

scharf
 shap
 agudo
 acuto

flexibel
 flexible
 flexible
 flessibile

KNAPP-ROLLET

032-275-002 - 032-275-004 13,0 cm / 5¹/₈"



032

Feine Wundhäkchen
Fine Hooklets
Ganchos y Ganchitos finos
Uncini sottile



032-277-002

scharf
shap
agudo
acuto



032-279-002

stumpf
blunt
romo
smusso



032-281-003

scharf
shap
agudo
acuto



032-283-003

stumpf
blunt
romo
smusso

AXENFELD

032-277-002 - 032-283-003 15,0 cm / 6"

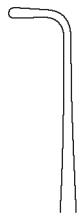

032-297-130



032-297-140

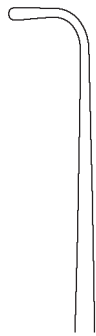

032-297-150

GRAEFE

032-297-130 13,0 cm / 5 1/8"
032-297-140 14,0 cm / 5 1/2"
032-297-150 15,0 cm / 6"



ELSCHMIG
 032-321-130

CASTROVIEJO
 032-323-130

CASTROVIEJO
 032-323-140

032-321-130 - 032-323-130 13,0 cm / 5¹/₈"
 032-323-140 14,0 cm / 5¹/₂"

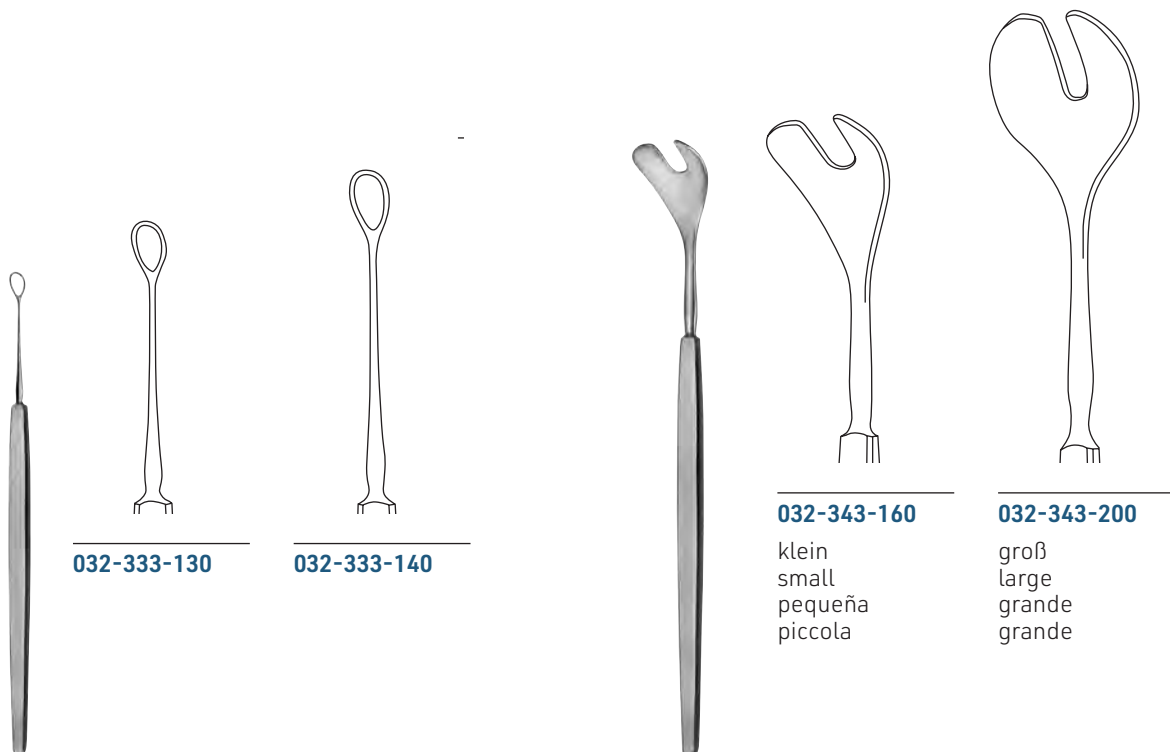

WEBER
 032-333-130 13,0 cm / 5¹/₈"
 032-333-140 14,0 cm / 5¹/₂"

WELLS
 032-343-160
 032-343-200

032-343-160
 klein
 small
 pequeña
 piccola

032-343-200
 groß
 large
 grande
 grande



032

Chalationslöffel
Chalazion Curettes
Cucharillas para chalaziòn
Cucchiai per calazio

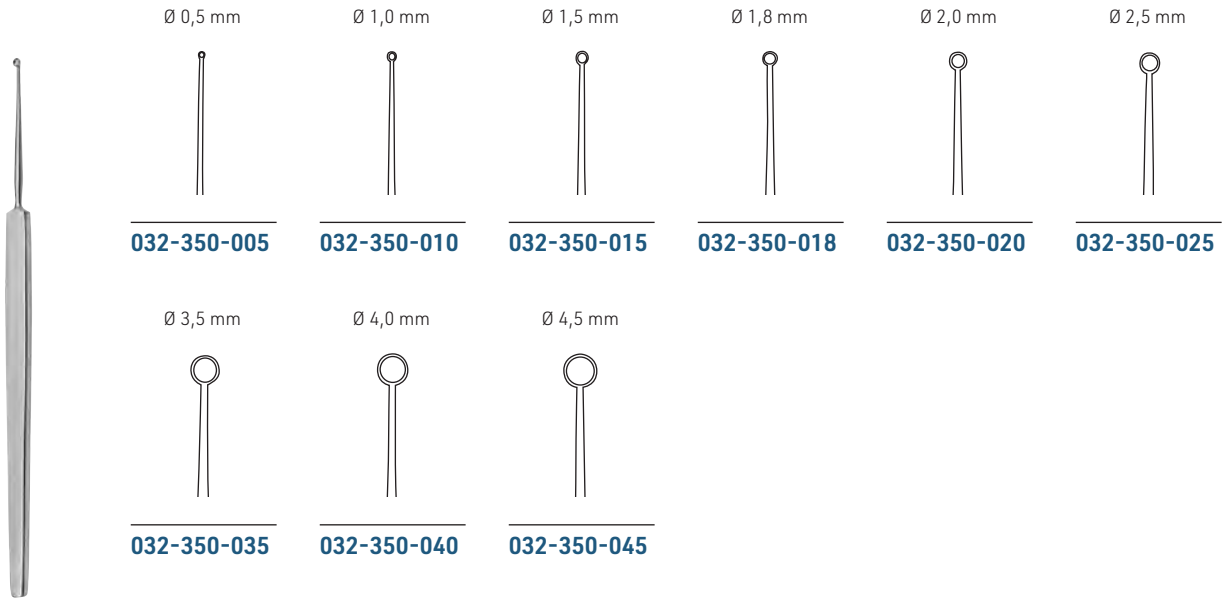

MEYHOEFER

032-350-005 - 032-350-045

13,0 cm / 5 1/8"

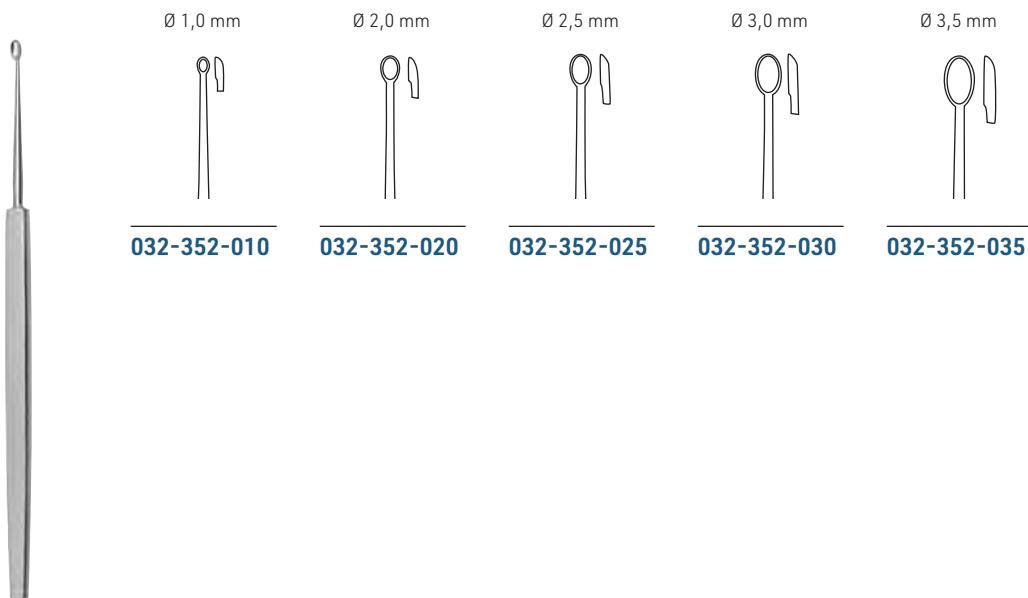

HEBRA

032-352-010 - 032-352-035

13,0 cm / 5 1/8"

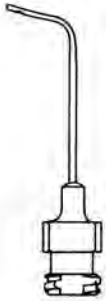

CASTROVIEJO
032-361-010 1,0 mm

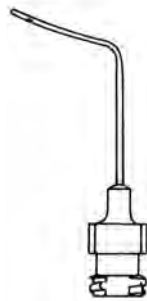

CASTROVIEJO
032-361-015 1,5 mm



LUER LOCK
032-363-027 27 Gauch



LUER LOCK
032-363-030 30 Gauch



032-420-010
 Griff allein
 Handle only
 Mango suelto
 Manico solo

Ø 1,5 mm



032-420-015

Ø 2,0 mm



032-420-020

ELLIOT

032-420-000

Satz komplett bestehend aus:
 1 Griff Art.-Nr. 032-420-010
 2 Trephinen Ø 1,5 mm, Art.-Nr. 032-420-015
 2 Trephinen Ø 2,0 mm, Art.-Nr. 032-420-020

Set complete consisting of:
 1 Handle Ref.-No. 032-420-010
 2 Trephines Ø 1,5 mm, Ref.-No. 032-420-015
 2 Trephinen Ø 2,0 mm, Ref.-No. 032-420-020

Juego completo compuesto de:
 1 Griff Ref.-No. 032-420-010
 2 Trépanos Ø 1,5 mm, Ref.-No. 032-420-015
 2 Trépanos Ø 2,0 mm, Ref.-No. 032-420-020

Set completo composto da:
 1 Manico Ref.-No. 032-420-010
 2 Trapani Ø 1,5 mm, Ref.-No. 032-420-015
 2 Trapani Ø 2,0 mm, Ref.-No. 032-420-020



032

Stanzen, Meißel, Meßzirkel
Punches, Chisels, Measuring Caliper
Pinzas saca-bocados, Cinceles, Compases para medición
Pinze tagliente, Sgorbie, compassi per misurare



HOLTH

032-441-090 9,0 cm / 3 1/2"



WEST

032-442-160 16,0 cm / 6 1/4"



WEST

032-444-160 16,0 cm / 6 1/4"



CASTROVIEJO

032-450-015

Meßbereich: 15 mm
Measuring Range: 15 mm
Alcance de medición: 15 mm
Campo di misura: 15 mm



CASTROVIEJO

032-450-020

Meßbereich: 20 mm
Measuring Range: 20 mm
Alcance de medición: 20 mm
Campo di misura: 20 mm

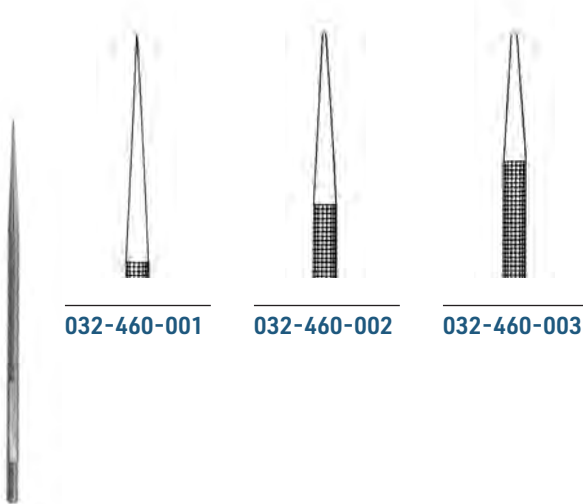

WILDER
 032-460-001 - 032-460-003

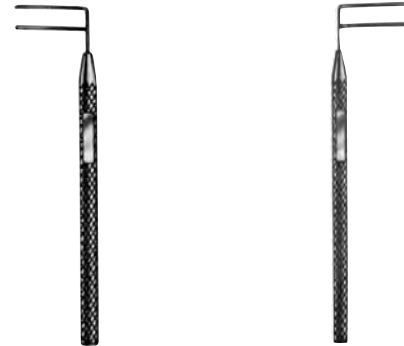

HARMS
 032-465-001
 links
 left
 izquierda
 sinistra

HARMS
 032-465-002
 rechts
 right
 derecha
 destra



zylindrisch/geknöpft
 cylindrical/pointed
 cilíndrico/abotonado
 cilindrico/abbottonato

Neusilber
 German silver
 plata alemana
 in argento

BOWMAN	FIG.	
032-470-000	0/0	0,8 mm
032-470-011	1/1	0,9 mm
032-470-022	2/2	1,1 mm
032-470-033	3/3	1,3 mm
032-470-044	4/4	1,4 mm
032-470-055	5/5	1,5 mm
032-470-066	6/6	1,6 mm
032-470-077	7/7	1,8 mm
032-470-088	8/8	1,9 mm



zylindrisch
 cylindrical
 cilíndrico
 cilindrico

Neusilber
 German silver
 plata alemana
 in argento

BOWMAN	FIG.	
032-472-000	00/0	0,7/0,8 mm
032-472-001	0/1	0,8/0,9 mm
032-472-012	1/2	0,9/1,1 mm
032-472-023	2/3	1,1/1,3 mm
032-472-034	3/4	1,3/1,4 mm
032-472-045	4/5	1,4/1,5 mm
032-472-056	5/6	1,5/1,6 mm
032-472-067	6/7	1,6/1,8 mm
032-472-078	7/8	1,8/1,9 mm



geknöpft
 pointed
 abotonado
 abbottonato

Neusilber
 German silver
 plata alemana
 in argento

BOWMAN	FIG.	
032-474-000	00/0	0,7/0,8 mm
032-474-001	0/1	0,8/0,9 mm
032-474-012	1/2	0,9/1,1 mm
032-474-023	2/3	1,1/1,3 mm
032-474-034	3/4	1,3/1,4 mm
032-474-045	4/5	1,4/1,5 mm
032-474-056	5/6	1,5/1,6 mm
032-474-067	6/7	1,6/1,8 mm
032-474-078	7/8	1,8/1,9 mm



032

Doppelinstrumente
Double-ended Instruments
Instrumentos dobles
Strumenti doppio

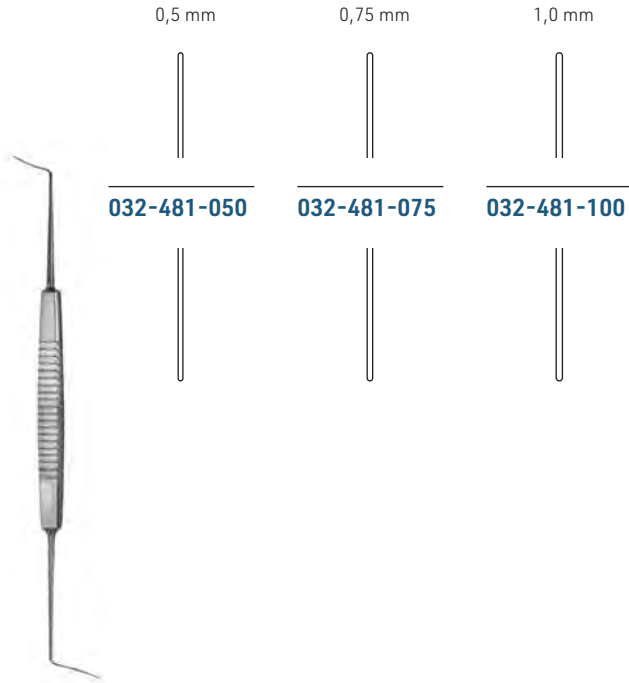

CASTROVIEJO

032-481-050 - 032-481-100



Flachmeißel
Chisel
Cincel
Scalpello

DIX

032-490-120 12,0 cm / 4³/₄"



Hohlmeißel
Gouge
Gubia
Sgorbie

DIX

032-492-120 12,0 cm / 4³/₄"

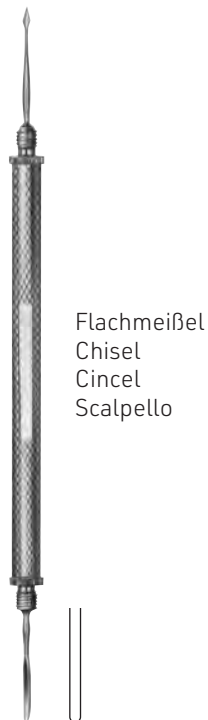

Flachmeißel
Chisel
Cincel
Scalpello

032-494-130 13,0 cm / 5¹/₈"

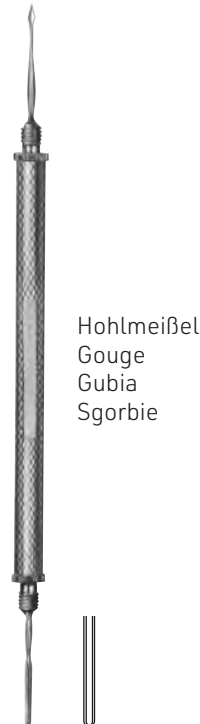

Hohlmeißel
Gouge
Gubia
Sgorbie

032-496-130 13,0 cm / 5¹/₈"

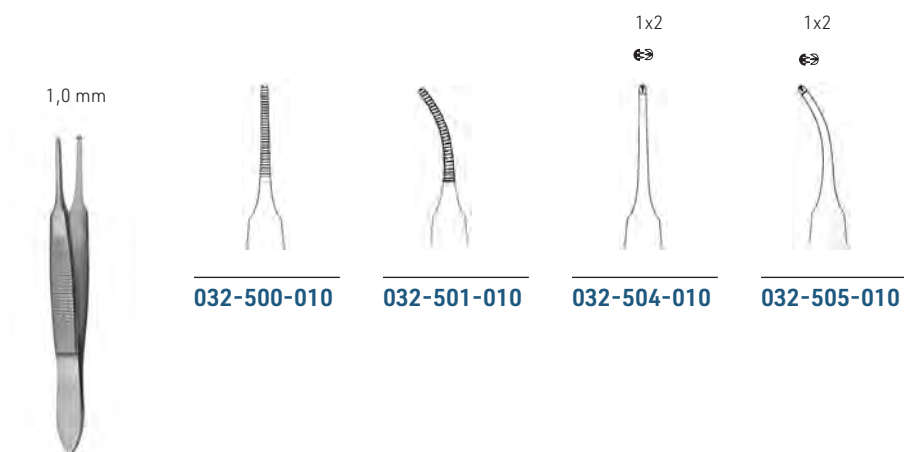

GRAEFE

032-500-010 - 032-505-010 7,0 cm / 2³/₄"

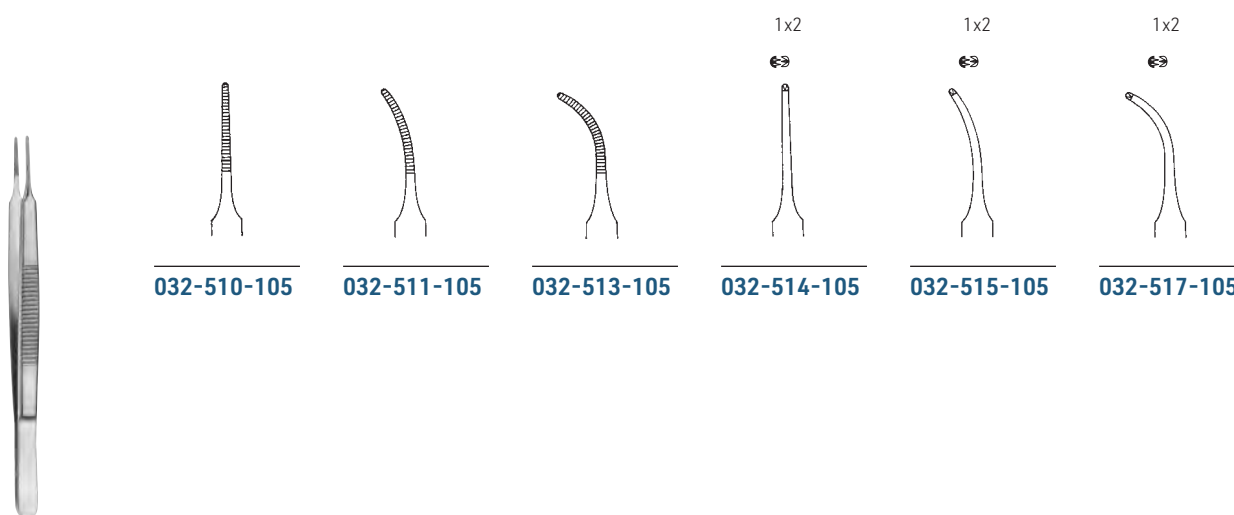

STEVENS

032-510-105 - 032-517-105 10,5 cm / 4¹/₂"



032

Irispinzetten, Fixierpinzetten
Iris Forceps, Fixation Forceps
Pinzas para iris, Pinzas de fijación
Pinze per iride, Pinze per fissare



MOD. BONN

032-542-070 7,0 cm / 2³/₄"
032-542-100 10,0 cm / 4"



BISHOP-HARMAN

032-544-085 - 032-550-085 8,5 cm / 3¹/₂"

0,8 mm

1x2



032-544-085

032-546-085

0,5 mm

1x2



032-548-085

032-550-085

fein
fine
fina
fina

fein
fine
fina
fina

1x2 0,4 mm

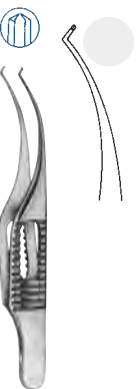

BARRAQUER-KATZIN

032-553-070 7,0 cm / 2³/₄"

1x2 0,12 mm

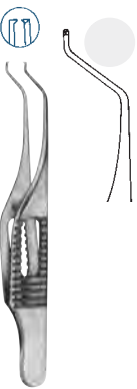

TROUTMAN (COLIBRI)

032-555-075 7,5 cm / 3"

1x2 0,12 mm

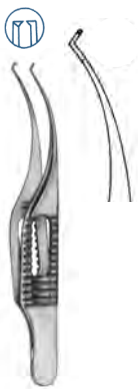

BARRAQUER (COLIBRI)

032-557-070 7,0 cm / 2³/₄"

1x2 0,12 mm



BARRAQUER-KATZIN (COLIBRI)

032-559-070 7,0 cm / 2³/₄"

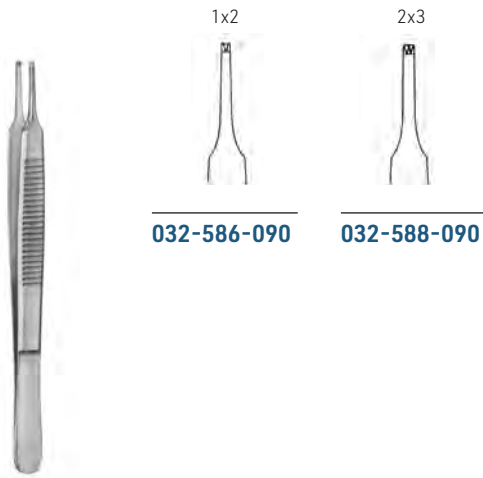

LESTER

032-586-090 - 032-588-090 9,0 cm / 3 1/2"

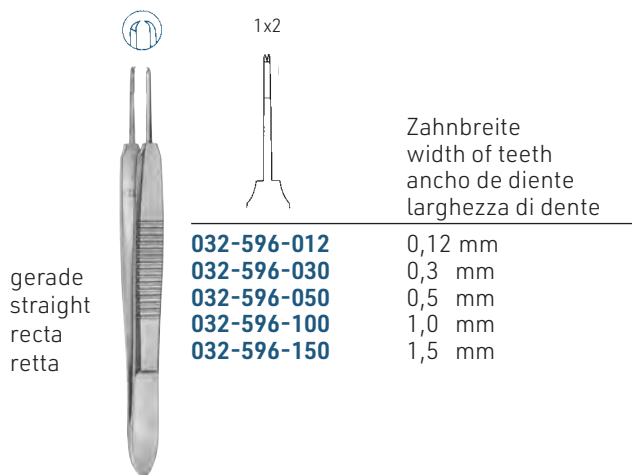

gerade
straight
recta
retta

CASTROVIEJO

032-596-012 - 032-596-150 10,0 cm / 4"

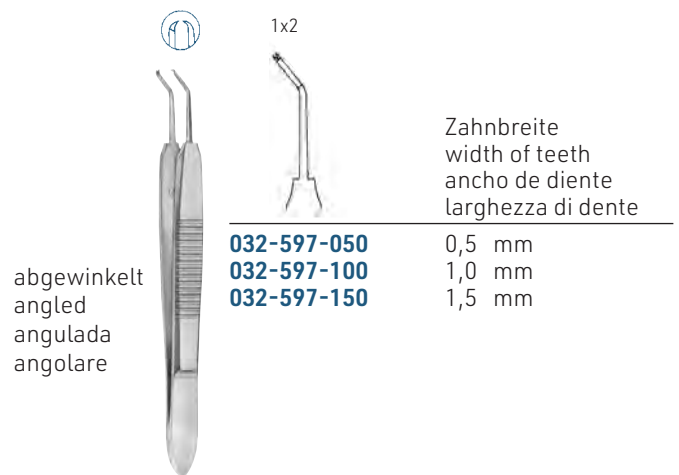

abgewinkelt
angled
angulada
angolare

CASTROVIEJO

032-597-050 - 032-597-150 10,0 cm / 4"



032

Nahtpinzetten,
Suture Forceps
Pinzas para sutura
Pinze per sutura

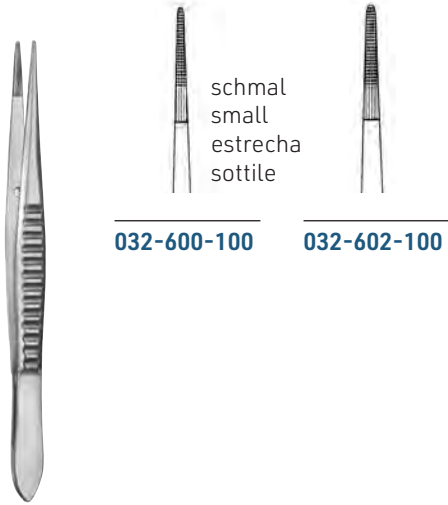

032-600-100

032-602-100

BONACCOLTO

032-600-100 - 032-602-100

10,0 cm / 4"

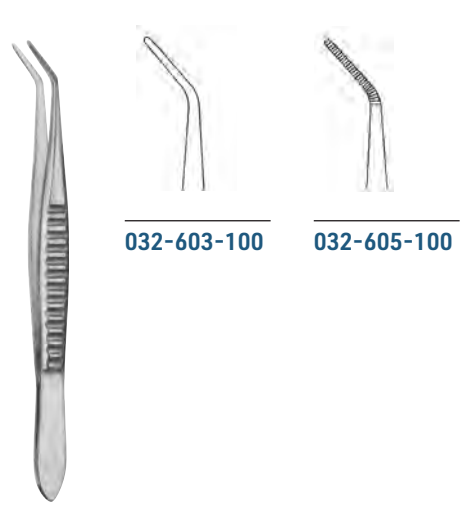

032-603-100

032-605-100

NUGENT

032-603-100 - 032-605-100

10,0 cm / 4"



SNELLEN

032-625-100

10,0 cm / 4"



SNELLEN

032-627-100

10,0 cm / 4"

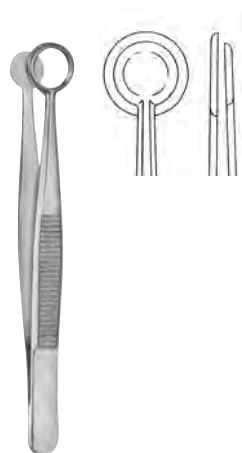

AYER

032-630-090 9,0 cm / 3 1/2"

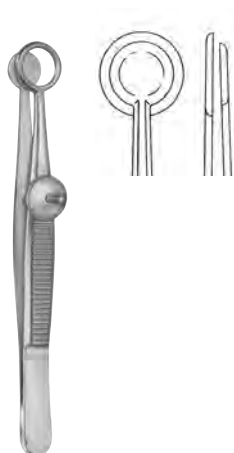

AYER

032-632-090 9,0 cm / 3 1/2"

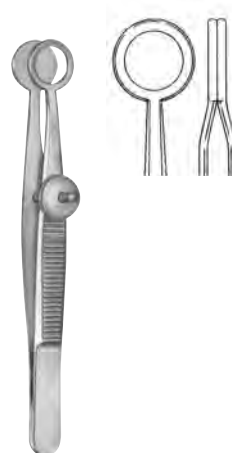

LAMBERT

032-634-090 9,0 cm / 3 1/2"

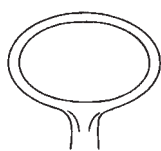

032-636-001

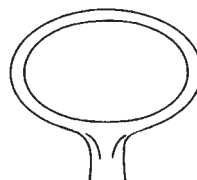

032-636-002

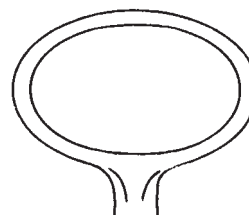

032-636-003

DESMARRES

032-636-001 - 032-636-003 9,0 cm / 3 1/2"



032

Mikro-Scheren
Micro Scissors
Micro Tijeras
Micro Forbici



links
left
izquierda
sinistra

KATZIN-BARRAQUER

032-701-100 10,0 cm / 4"



rechts
right
derecha
destro

KATZIN-BARRAQUER

032-703-100 10,0 cm / 4"



032-704-100



032-705-100

032-704-100 - 032-705-100

10,0 cm / 4"



CASTROVIEJO

032-707-100 10,0 cm / 4"



CASTROVIEJO

032-709-100 10,0 cm / 4"



AEBLI

032-711-100 10,0 cm / 4"

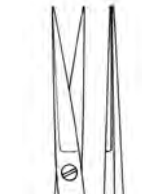

032-720-120

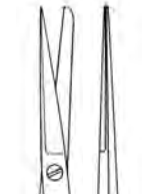

032-722-120

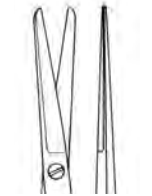

032-724-120



032-735-110

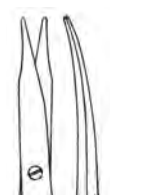

032-737-110

spitz
pointed
aguda
acuto

stumpf
blunt
roma
smusso

NOYES

032-720-120 - 032-724-120 12,0 cm / 4³/₄"

WESTCOTT

032-735-110 - 032-737-110 11,0 cm / 4¹/₂"



CASTROVIEJO

032-743-090 9,0 cm / 3¹/₂"



032-751-100



032-753-100

spitz
pointed
aguda
acuto

stumpf
blunt
roma
smusso

CASTROVIEJO

032-751-100 - 032-753-100 10,0 cm / 4"



032

Iridektomiescheren,
Iridectomy Scissors
Tijeras para iridectomia
Forbici per iridectomia



032-756-080



032-757-080

VANNAS

032-756-080 - 032-757-080

8,0 cm / 3 1/4"



032-760-085



032-761-085



032-763-085

VANNAS-MOD. TÜBINGEN

032-760-085 - 032-763-085

8,5 cm / 3 1/2"



5 mm

032-771-005



7 mm

032-771-007

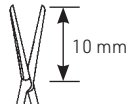

10 mm

032-771-010

BARRAQUER

032-771-005 - 032-771-010

5,5 cm / 2 1/4"



links
left
izquierda
sinistra

CASTROVIEJO

032-781-100 10,0 cm / 4"



rechts
right
derecha
destra

CASTROVIEJO

032-783-100 10,0 cm / 4"



links
left
izquierda
sinistra

CASTROVIEJO

032-785-110 11,0 cm / 4 1/2"



rechts
right
derecha
destra

CASTROVIEJO

032-787-110 11,0 cm / 4 1/2"



032

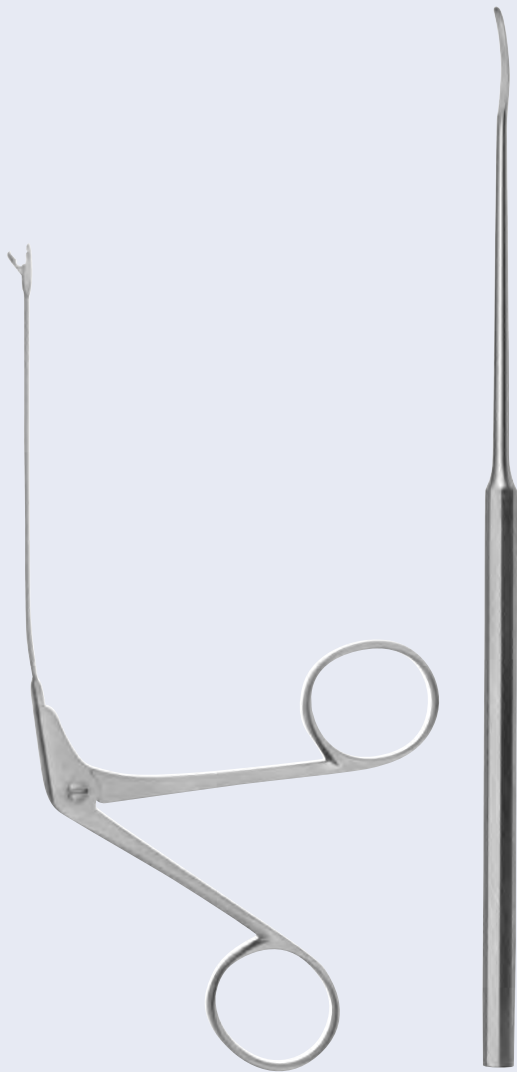

034

Otologie
Otology
Otología
Otologia



WULLSTEIN
 034-002-040 - 034-007-040

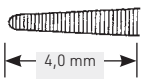
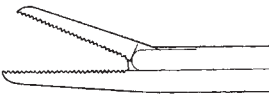
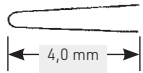
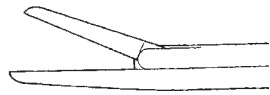

034-010-040 - 034-017-040



034-002-040

4,0 mm x 1,0 mm
 geriefte Maulteile, gerade
 serrated jaws, straight
 bocas estriadas, recta
 morsi scanalati, rette



034-003-040

4,0 mm x 1,0 mm
 geriefte Maulteile, aufgebogen
 serrated jaws, curved up
 bocas estriadas, curva hacia arriba
 morsi scanalati, curve verso l'alto



034-005-040

4,0 mm x 1,0 mm
 geriefte Maulteile, rechts gebogen
 serrated jaws, curved to the right
 bocas estriadas, curva a la derecha
 morsi scanalati, curve verso destra



034-007-040

4,0 mm x 1,0 mm
 geriefte Maulteile, links gebogen
 serrated jaws, curved to the left
 bocas estriadas, curva a la izquierda
 morsi scanalati, curve verso sinistra



034-010-040

4,0 mm x 0,8 mm
 glatt, gerade
 smooth, straight
 lisa, recta,
 liscia, retta



034-012-040

4,0 mm x 0,8 mm
 gerieft, gerade
 serrated, straight
 estriada, recta,
 con scanalura, retta



034-013-040

4,0 mm x 0,8 mm
 aufgebogen, gerieft
 bent upwards, serrated
 curva por arriba, estriada
 curva in alto, con scanallatura



034-015-040

4,0 mm x 0,8 mm
 rechts, gerieft
 righth, serrated
 derrecha, estriada
 estra, con scanallatura

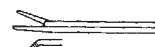

034-017-040

4,0 mm x 0,8 mm
 links, gerieft
 left, serrated
 izquierda, estriada
 sinistra, con scanallatura

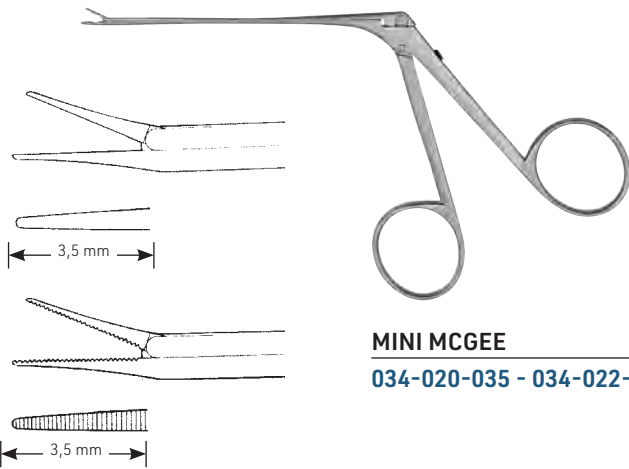

MINI MCGEE
 034-020-035 - 034-022-035

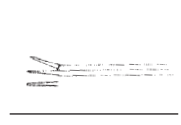

034-020-035

3,5 mm x 0,6 mm
 glatt, gerade
 smooth, straight
 lisa, recta
 liscia, retta



034-022-035

3,5 mm x 0,6 mm
 gerieft, gerade
 serrated, straight
 estriada, recta
 con scanalatura, retta

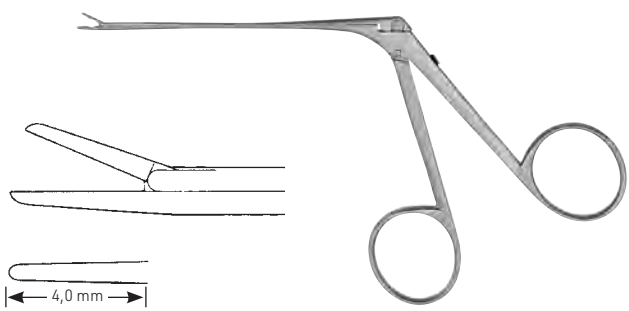

034-030-040

4,0 mm x 0,6 mm
 glatt, gerade
 smooth, straight
 lisa, recta
 liscia, retta

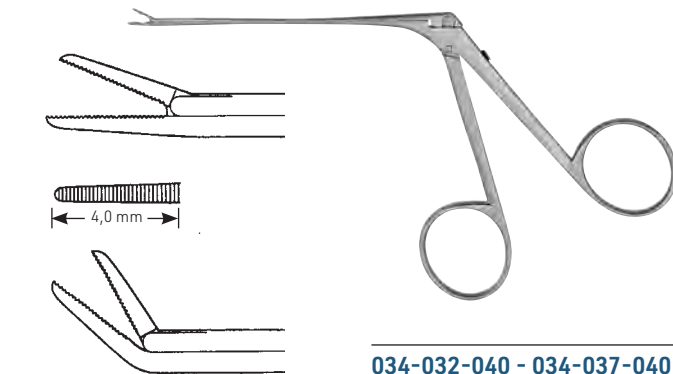

034-032-040

4,0 x 0,6 mm
 gerieft, gerade
 serrated, straight
 estriada, recta,
 con scanalura, retta

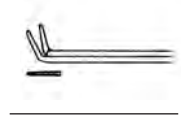

034-033-040

4,0 x 0,6 mm
 aufgebogen, gerieft
 bent upwards, serrated
 curva por arriba, estriada
 curva in alto, con scanallatura

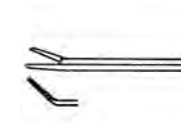

034-035-040

4,0 x 0,6 mm
 rechts, gerieft
 righth, serrated
 derecha, estriada
 destra, con scanallatura



034-037-040

4,0 x 0,6 mm
 links, gerieft
 left, serrated
 izquierda, estriada
 sinistra, con scanallatura

034-032-040 - 034-037-040



034

Mikro-Ohrzangchen
 Micro Ear Forceps
 Micro Pinzas auriculares
 Micro Pinze auricolari

1,0 x 0,9 mm
 Loffel
 cup
 cucharilla
 cucchiaio

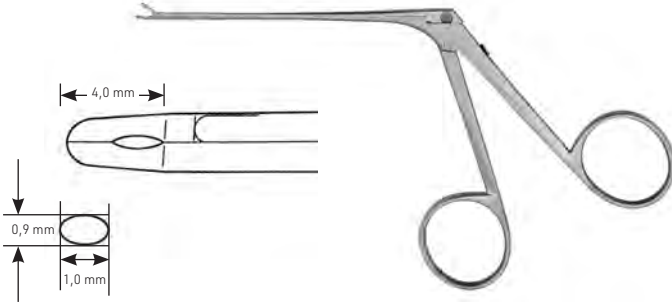

034-040-040 - 034-047-040



4,0 mm
 gerade
 straight
 recta
 retta

034-040-040



4,0 mm
 aufgebogen
 curved up
 curva por arriba
 curva in alto

034-043-040



4,0 mm
 rechts
 right
 derecha
 destra

034-045-040



4,0 mm
 links
 left
 izquierda
 sinistra

034-047-040

0,6 x 0,5 mm
 Loffel
 cup
 cucharilla
 cucchiaio

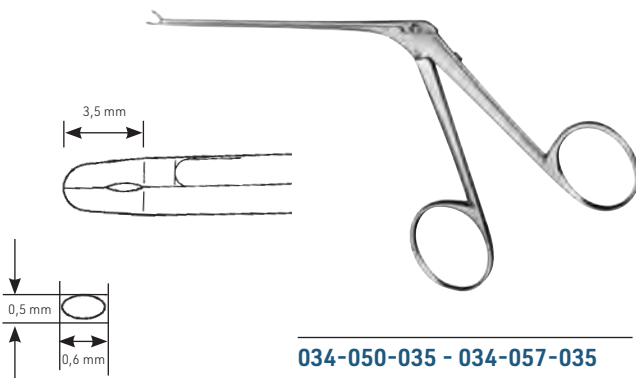

034-050-035 - 034-057-035

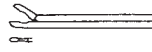

3,5 mm
 gerade
 straight
 recta
 retta

034-050-035



3,5 mm
 aufgebogen
 curved up
 curva por arriba
 curva in alto

034-053-035

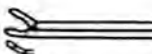

3,5 mm
 rechts
 right
 derecha
 destra

034-055-035

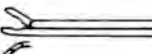

3,5 mm
 links
 left
 izquierda
 sinistra

034-057-035

sehr fein
 very fine
 muy fina
 molto delicata

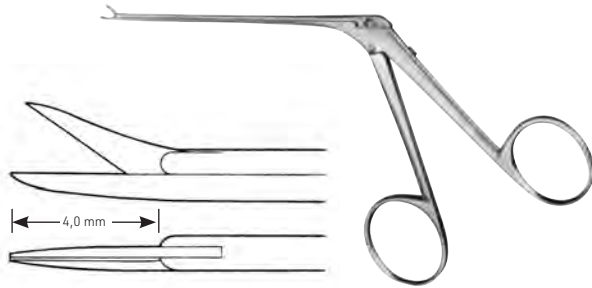

BELLUCCI
 034-060-040 - 034-067-040



gerade
 straight
 recta,
 retta

034-060-040

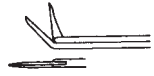

aufgebogen
 curved up
 curva por arriba
 curva in alto

034-063-040



rechts
 right
 derecha
 destra

034-065-040



links
 left
 izquierda
 sinistra

034-067-040

0,8 mm
 Schaft
 shaft
 vastago
 gambo

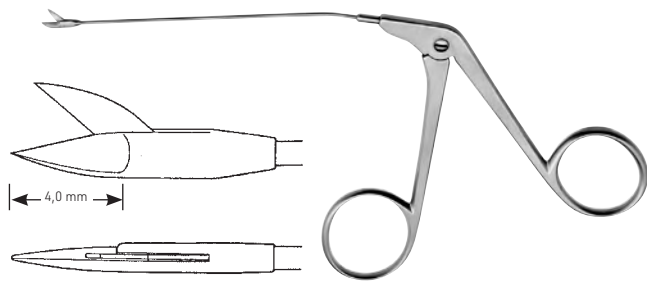

WULLSTEIN
 034-070-040 - 034-077-040



gerade
 straight
 recta
 retta

034-070-040

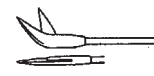

aufgebogen
 curved up
 curva por arriba
 curva in alto

034-073-040

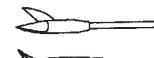

rechts
 right
 derecha
 destra

034-075-040



links
 left
 izquierda
 sinistra

034-077-040



034

Mikro-Ohrzangchen
Micro Ear Forceps
Micro Pinzas auriculares
Micro Pinze auricolari

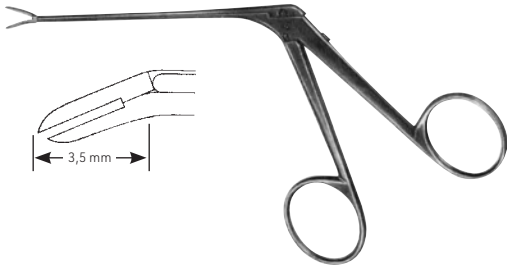

MC GEE
034-081-035 - 034-081-060



3,5 x 0,8 mm
abgebogen
curved downward
curva por abajo
curva in basso

034-081-035

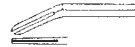

6,0 x 0,8 mm
abgebogen
curved downward
curva por abajo
curva in basso

034-081-060



WULLSTEIN
034-082-010 - 034-087-010



runde Maulteile, \varnothing 1,0 mm, gerade
round cup jaws, \varnothing 1,0 mm, straight
copas redondas, \varnothing 1,0 mm, recta
morsi rotondi, \varnothing 1,0 mm, retta

034-082-010



runde Maulteile, \varnothing 1,0 mm, aufgebogen
round cup jaws, \varnothing 1,0 mm, curved up
copas redondas, \varnothing 1,0 mm, curva hacia arriba
morsi rotondi, \varnothing 1,0 mm, curve verso l'alto

034-083-010



runde Maulteile, \varnothing 1,0 mm, rechts gebogen
round cup jaws, \varnothing 1,0 mm, curved to the right
copas redondas, \varnothing 1,0 mm, curva a la derecha
morsi rotondi, \varnothing 1,0 mm, curve verso destra

034-085-010



runde Maulteile, \varnothing 1,0 mm, links gebogen
round cup jaws, \varnothing 1,0 mm, curved to the left
copas redondas, \varnothing 1,0 mm, curva a la izquierda
morsi rotondi, \varnothing 1,0 mm, curve verso sinistra

034-087-010

Hammerkopffzangchen
Malleus Nipper
Pinza para cabezal del maleolo
Pinz per testa del martelletto

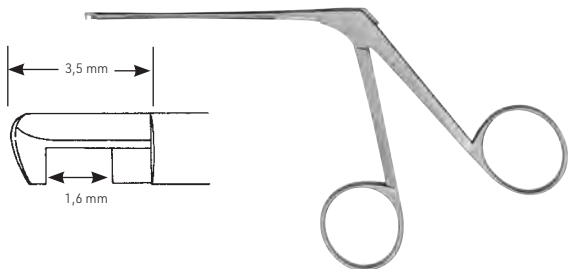

HOUSE-DIETER
034-091-035 - 034-093-035

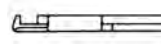

3,5 x 1,6 mm
oben schneidend
up-cutting
corte arriba
tagliente in alto

034-091-035

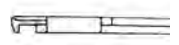

3,5 x 1,6 mm
unten schneidend
down-cutting
corte abajo
tagliente in basso

034-093-035

Hammerkopfzängchen
 Malleus Nipper
 Pinza para cabezal del malèolo
 Pinz per testa del martelletto

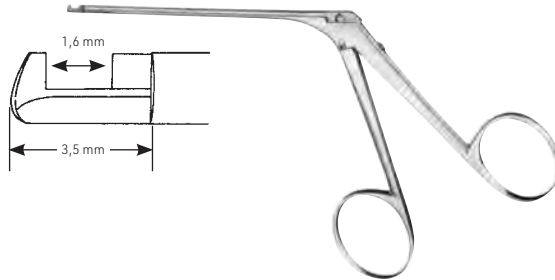

HOUSE-DIETER
 034-095-035 - 034-097-035

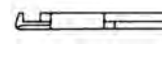

034-095-035

3,5 mm x 1,6 mm
 rechts schneidend
 right-cutting
 corte derecho
 tagliente a destra

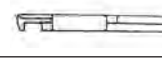

034-097-035

3,5 mm x 1,6 mm
 links schneidend
 left-cutting
 corte izquierdo
 tagliente a sinistra

Einführungszängchen
 Introducing Forceps
 Pinza para introducir
 Pinza per introduzione

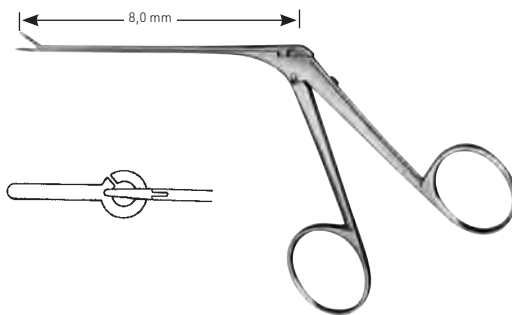

FULLER
 034-100-080



WULLSTEIN
 034-102-010 - 034-107-010



034-102-010

ovale Maulteile, ø 1,0 mm, gerade
 oval cup jaws, ø 1,0 mm, straight
 copas ovales, ø 1,0 mm, recta
 morsi ovale, ø 1,0 mm, retta



034-103-010

ovale Maulteile, ø 1,0 mm, aufgebogen
 oval cup jaws, ø 1,0 mm, curved up
 copas ovales, ø 1,0 mm, curva hacia arriba
 morsi ovali, ø 1,0 mm, curve verso l'alto



034-105-010

ovale Maulteile, ø 1,0 mm, rechts gebogen
 oval cup jaws, ø 1,0 mm, curved to the right
 copas ovales, ø 1,0 mm, curva a la derecha
 morsi ovali, ø 1,0 mm, curve verso destra



034-107-010

ovale Maulteile, ø 1,0 mm, links gebogen
 oval cup jaws, ø 1,0 mm, curved to the left
 copas ovales, ø 1,0 mm, curva a la izquierda
 morsi ovali, ø 1,0 mm, curve verso sinistra



034

Mikro-Ohrmesser
Micro Ear Knives
Micro Cuchillos auriculares
Micro Coltelli



SCHUKNECHT

034-111-160 16,0 cm / 6 1/4"

Rollenmesser
Rotary Knife
Cuchillo redondo
Coltello rotondo



SCHUKNECHT

034-113-160 16,0 cm / 6 1/4"

Sichelmesser
Sickle Knife
Cuchillos de hoz
Coltello falcato come sinechia



WULLSTEIN

034-115-160 16,0 cm / 6 1/4"

Sichelmesser
Sickle Knife
Cuchillos de hoz
Coltello falcato come sinechia



TABB

034-117-160 16,0 cm / 6 1/4"

Schleimhautmesser
Mucosa Knife
Cuchillo para mucosa
Coltello per mucosa



PLESTER

034-119-160 16,0 cm / 6 1/4"

Lappenmesser
Flap Knife
Cuchillo para lóbulos
Coltello per lobi

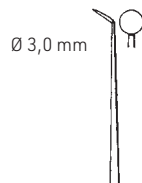

FIG. 1
034-121-001

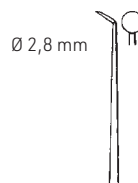

FIG. 2
034-121-002

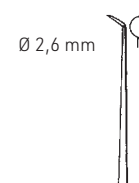

FIG. 3
034-121-003

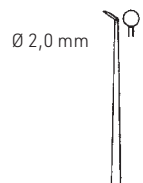

FIG. 4
034-121-004



ROSEN

034-121-001 - 034-121-007 16,0 cm / 6 1/4"

Rundschnittemesser
Circular Cut Knives
Cuchillos para cortes redondos
Coltelli circolari

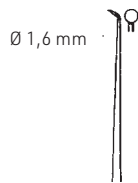

FIG. 5
034-121-005

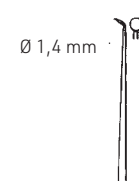

FIG. 6
034-121-006

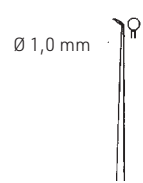

FIG. 7
034-121-007



BARBARA
 034-125-001



BARBARA
 034-125-002



BARBARA
 034-125-003



ROSEN
 034-125-004



BARBARA
 034-131-003 0,3 mm
 034-131-006 0,6 mm
 034-131-010 1,0 mm



BARBARA
 034-133-003 0,3 mm
 034-133-006 0,6 mm
 034-133-010 1,0 mm
 034-133-012 1,2 mm
 034-133-015 1,5 mm
 034-133-020 2,0 mm
 034-133-025 2,5 mm



BARBARA
 034-135-003 0,3 mm
 034-135-006 0,6 mm
 034-135-010 1,0 mm
 034-135-012 1,2 mm
 034-135-015 1,5 mm
 034-135-020 2,0 mm
 034-135-025 2,5 mm



BARBARA
 034-137-005 0,5 mm
 034-137-010 1,0 mm



034-125-001 - 034-137-010 16,0 cm / 6 1/4"



034

Mikro-Ohrnadeln, Mikro-Ohrhäkchen
Micro Ear Needles, Micro Ear Hooks
Micro Aguja auriculares, Mirco Ganchitos auriculares
Micro Aghi auricolari, Micro Uncini auricolari



90°

034-139-003 0,3 mm
034-139-006 0,6 mm
034-139-010 1,0 mm



90°

034-141-003 0,3 mm
034-141-006 0,6 mm
034-141-010 1,0 mm



MC GEE

034-143-005 0,5 mm
034-143-010 1,0 mm



MC GEE

034-145-005 0,5 mm
034-145-010 1,0 mm



BARBARA

034-147-155



ROSEN

034-149-155

034-139-003 - 034-149-155 15,5 cm / 6"

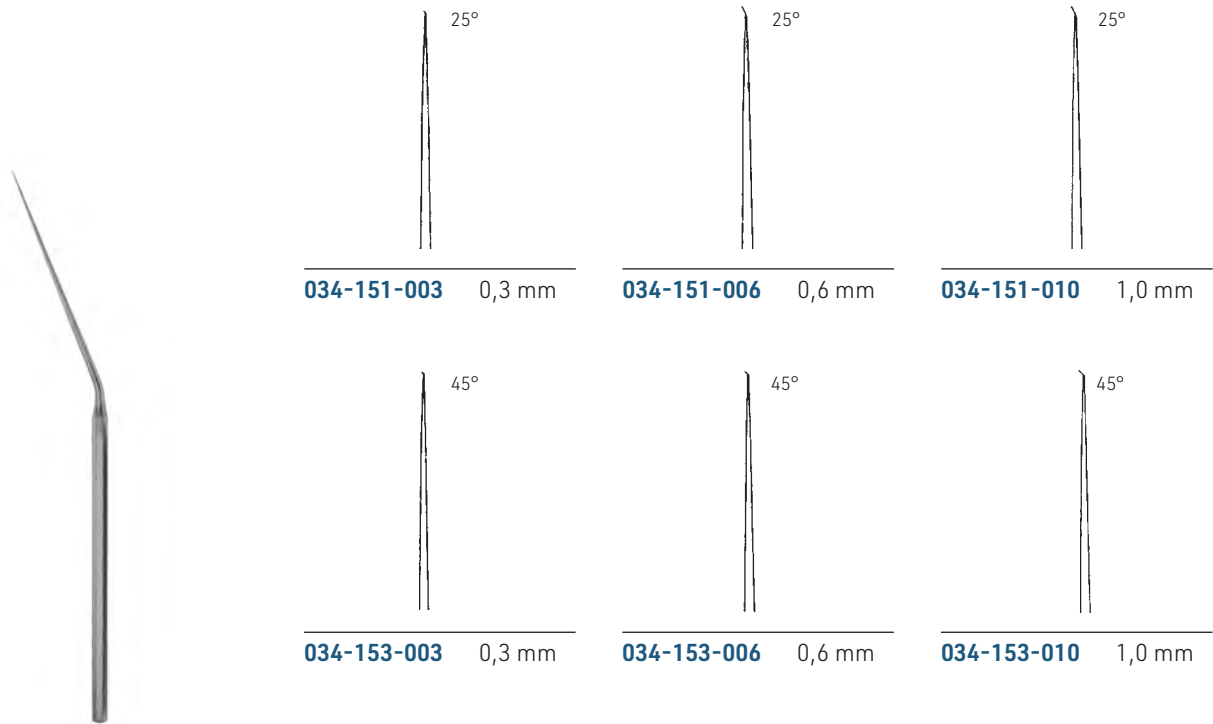

25°
034-151-003 0,3 mm

25°
034-151-006 0,6 mm

25°
034-151-010 1,0 mm

45°
034-153-003 0,3 mm

45°
034-153-006 0,6 mm

45°
034-153-010 1,0 mm

034-151-003 - 034-153-010 15,5 cm / 6"

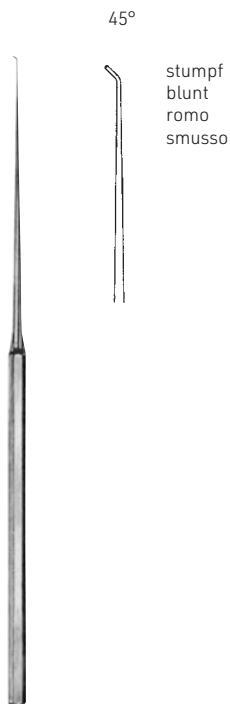

SHEA
034-155-020 2,0 mm
 Sondierhaken
 Exploring Hook
 Ganchito explorador
 Uncino di sondaggio

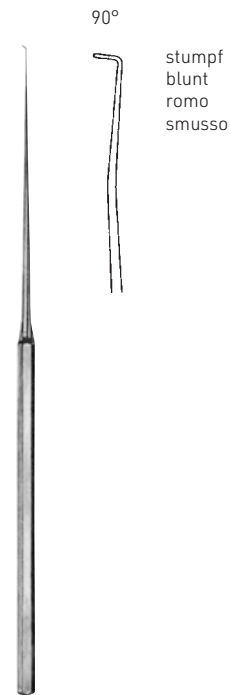

AUSTIN
034-157-030 3,0 mm
 Attikusdissektor
 Attic Dissector
 Disecador para el ático
 Dissettore per l'attico



034

Mikro-Ohrhäkchen
Micro Ear Hooks
Micro Ganchitos auriculares
Micro Uncini auricolari

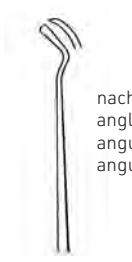

nach rechts abgewinkelt
angled to right
angulada por derecha
angulata a destra

034-161-001



nach links abgewinkelt
angled to left
angulada por izquierda
angulata a sinistra

034-161-002

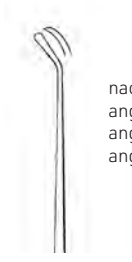

nach rechts abgewinkelt
angled to right
angulada por derecha
angulata a destra

034-163-001



nach links abgewinkelt
angled to left
angulada por izquierda
angulata a sinistra

034-163-002

FISCH

034-161-001 - 034-163-002 15,5 cm / 6"

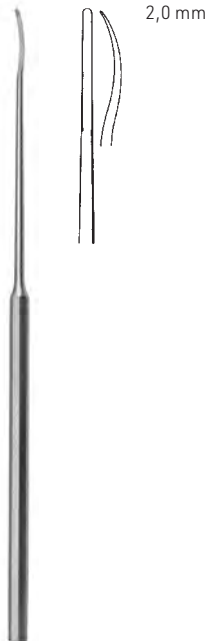

2,0 mm

ROSEN

034-165-155 15,5 cm / 6"

Mikro-Ohrraspatorium
Micro Ear Periosteal Elevator
Micro legra auricular
Micro Raspatore auricolare



034-170-035 3,5 mm



034-170-040 4,0 mm



034-170-045 4,5 mm



034-170-050 5,0 mm

HOUSE

034-170-035 - 034-170-050 15,5 cm / 6"

Mikro-Messsonde
Micro Measuring Rod
Micro sonda para medir
Micro Sonda per misurare



034-180-001

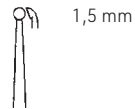

034-180-002

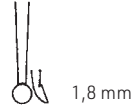
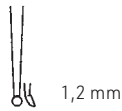

HOUSE

034-180-001 - 034-180-002 15,0 cm / 6"

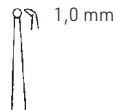

034-181-001



034-181-002

stark abgewinkelt
strong angled
angulada fuerte
angulata forte

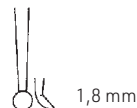

HOUSE

034-181-001 - 034-181-002 15,0 cm / 6"



034

Ohrspekula
Ear Specula
Espéculos auriculares
Specoli auricolari



HARTMANN Fig. 0-2

034-201-003 3,6 cm / 1 1/2"

Ohrspekula, Satz für Kinder
Ear Specula, set for children
Spéculums auriculares, juego para niños
Specoli auricolari, set per bambini

Fig. 0

034-200-030 3,0 mm

Fig. 1

034-200-040 4,0 mm

Fig. 2

034-200-050 5,0 mm

Fig. 3

034-200-060 6,0 mm

Fig. 4

034-200-075 7,5 mm



HARTMANN Fig. 2-4

034-202-003 3,6 cm / 1 1/2"

HARTMANN Fig. 1-4

034-202-004 3,6 cm / 1 1/2"

Ohrspekula, Satz für Erwachsene
Ear Specula, set for adults
Spéculums auriculares, juego para adultos
Specoli auricolari, set per adulti



TOYNBEE Fig. 2-4

034-211-003 3,6 cm / 1 1/2"

TOYNBEE Fig. 1-4

034-211-004 3,6 cm / 1 1/2"

Ohrspekula, Satz für Erwachsene
Ear Specula, set for adults
Spéculums auriculares, juego para adultos
Specoli auricolari, set per adulti



schwarz
black
negro
nero

FARRIOR Fig. 1-7

034-221-007 3,6 cm / 1 1/2"

Ohrspekula, Satz bestehend aus 7 Stück
Ear Specula, set consisting of 7 pieces
Spéculums auriculares, juego consiste de 7 piezas
Specoli auricolari, set composto di 7 pezzi

Fig. 1

034-210-040 4,0 mm

Fig. 2

034-210-050 5,0 mm

Fig. 3

034-210-060 6,0 mm

Fig. 4

034-210-075 7,5 mm

Fig. 1

034-220-055 5,5 mm

Fig. 3

034-220-075 7,5 mm

Fig. 5

034-220-095 9,5 mm

Fig. 7

034-220-115 11,5 mm

Fig. 2

034-220-065 6,5 mm

Fig. 4

034-220-085 8,5 mm

Fig. 6

034-220-105 10,5 mm



oval, schwarz
 oval, black
 ovalado, negro
 ovale, nero

ZÖLLNER Fig. 1-6

034-231-006 3,8 cm / 1 1/2"

Ohrspekula, Satz bestehend aus 6 Stück
 Ear Specula, set consisting of 6 pieces
 Spéculums auriculares, juego consiste de 6 piezas
 Specoli auricolari, set composto di 6 pezzi

Fig. 1
034-230-065 5,5 x 6,5 mm

Fig. 2
034-230-075 6,5 x 7,5 mm

Fig. 3
034-230-085 7,5 x 8,5 mm

Fig. 4
034-230-095 8,5 x 9,5 mm

Fig. 5
034-230-105 9,5 x 10,5 mm

Fig. 6
034-230-115 10,5 x 11,5 mm

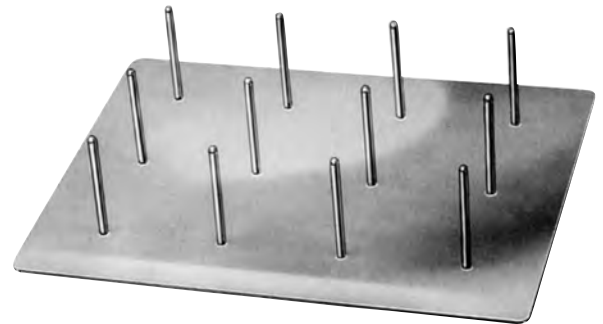

034-244-012

Ohrspekulaständer
 Ear Specula Storage Rack
 Soporte para espéculos auriculares
 Supporto per specoli auricolari



BOUCHERON Fig. 1-4

034-241-004

Ohrspekula, Satz bestehend aus 4 Stück
 Ear Specula, set consisting of 4 pieces
 Spéculums auriculares, juego consiste de 4 piezas
 Specoli auricolari, set composto di 4 pezzi

Fig. 1
034-240-042 4,2 mm

Fig. 2
034-240-052 5,2 mm

Fig. 3
034-240-062 6,2 mm

Fig. 4
034-240-072 7,2 mm



034

Stimmgabeln
Tuning Forks
Diapasones
Diapason

ALUMINIUM

034-301-005

Alu-Stimmgabel-Satz komplett im Etui bestehend aus 034-300-001 bis 034-300-005

Set of Tuning Forks (Alu) complete in case consisting of 034-300-001 till 034-300-005

Juego de diapasones (aluminio) completo en estuche compuesto de 034-300-01 hasta 034-300-005

Set da diapason (alluminio) completo in astuccio composito da 034-300-001 fino a 034-300-005

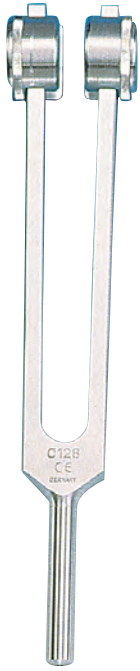

ALUMINIUM
034-300-001 c128



ALUMINIUM
034-300-002 C256



ALUMINIUM
034-300-003 C512



ALUMINIUM
034-300-004 C1024



ALUMINIUM
034-300-005 C2048

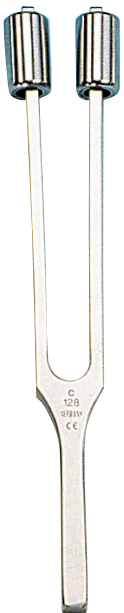

HARTMANN
034-304-001 c128



HARTMANN
034-304-002 c1256



HARTMANN
034-304-003 c2512



HARTMANN
034-304-004 c³1024



HARTMANN
034-304-005 c⁴2048



HARTMANN

034-305-005

Stimmgabel-Satz komplett im Etui bestehend aus 034-304-001 bis 034-304-005
Set of Tuning forks complete in case consisting of 034-304-001 till 034-304-005
Juego de diapasones completo en estuche compuesto de 034-304-001 hasta 034-304-005
Set da diapason completo in astuccio composto da 034-304-001 fino a 034-304-005



HARTMANN
034-310-001 c128



HARTMANN
034-310-002 c1256



HARTMANN
034-310-003 c⁵4096



HARTMANN
034-312-001 C64



034

Stimmgabeln
Tuning Forks
Diapasones
Diapason



LUCAE
034-320-001 c128



LUCAE
034-320-002 c1256



LUCAE
034-320-003 c2512



LUCAE
034-320-004 c31024



LUCAE
034-320-005 c42048



LUCAE
034-320-006 c54096

verschiebbar bis h 240
movable up to h 240
regulable hasta h 240
regolabile fino a h 240

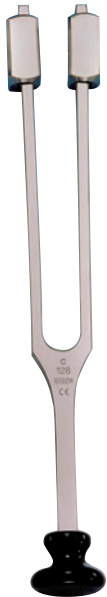

LUCAE
034-322-001 c128

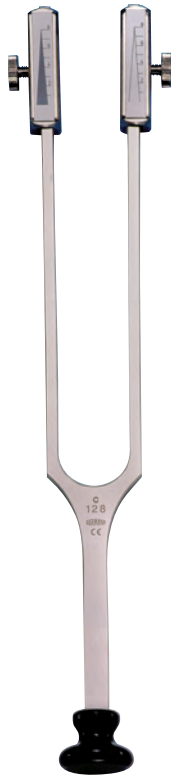

RYDEL-SEIFFERT
034-324-001 C64/c128

auch für Neurologie
also for neurology
para neurologia
per neurologia

mit Dämpfer = C64
with Dampers = C64
con sordinas = C64
con sordine = C64

ohne Dämpfer = c128
without dampers = c128
sin sordinas = c128
senza sordine = c128

ALUMINIUM-STIMMGABEL mit Perkussionshammer,
Nadelrad, Nadel und Pinsel im Etui

ALUMINIUM-Tuning Fork with Percussion hammer,
pin wheel, needle and brush in case

ALUMINIO-Diapason con martillo para percusion,
rueda de agujas, aguja y pincel en festuche

ALLUMINIO-Diapason con martello di riflesso, ruota
per l' ago, ago è pennello in astuccio



NEURO
034-326-001

verschiebbar bis g194
movable up to g194
regulable hasta g194
regolabile fino a g194

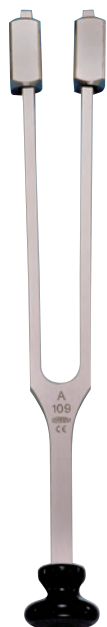

KÖNIG

034-328-001 A109



034-330-001 a1440



BARANY

034-340-000

034-340-001

Ohrlive, allein
Ear piece, only
Oliva, suelta
Oliva, sola



034

Ohrkatheter, Polypenschnürer
Ear Catheters, Polypus Snares
Sondas auriculares, Polipótomos
Sonde auricolari, Serranodi per polipi



Fig. 1

034-349-001



Fig. 2

034-349-002



Fig. 3

034-349-003

HARTMANN

034-349-001 - 034-349-003 15,0 cm / 6"



offenes Ende
open tip
punta abierta
punta aperta

KRAUSE

034-351-185 18,5 cm / 7 1/4"



geschlossenes Ende
closed tip
punta cerrada
punta chiusa

KRAUSE-VOSS

034-353-185 18,5 cm / 7 1/4"

Schnürerschlingen, Bündel mit 12 Stück
Snare loops, bundle with 12 pieces
Asas de alambre, manajo de 12 piezas
Lacci di filo di metallo, manello die 12 pezzi



7,5 cm

034-355-020 Ø 0,20 mm
034-355-025 Ø 0,25 mm
034-355-030 Ø 0,30 mm

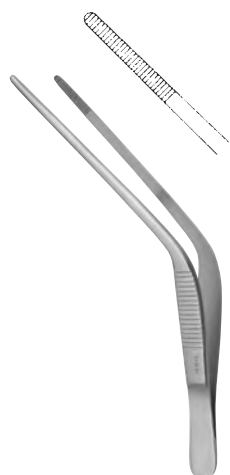

TROELTSCH (WILDE)
034-375-120 12,0 cm / 4³/₄"

↔ 1x2



TROELTSCH (WILDE)
034-381-120 12,0 cm / 4³/₄"



LUCAE
034-391-140 14,0 cm / 5¹/₂"



LUCAE
034-391-160 16,0 cm / 6¹/₄"



034

Ohrpolypenzangen
 Ear Polypus Forceps
 Pinzas para pólipos auriculares
 Pinze per polipi auricolari



TILLEY

034-401-140 14,0 cm / 5 1/2"

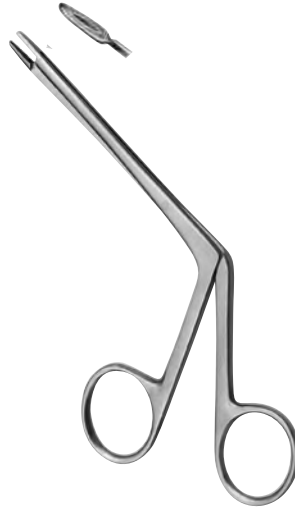

LITTAUER

034-403-120 12,0 cm / 4 3/4"



feines Modell
fine model
modelo fino
modello fino

HARTMANN

034-405-120 12,0 cm / 4 3/4"



HARTMANN

034-407-140 14,0 cm / 5 1/2"

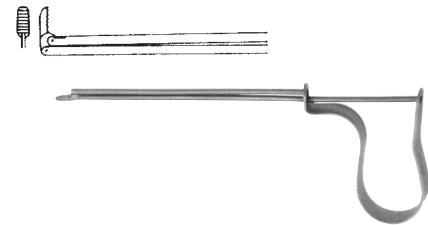

QUIRE

034-410-100 10,0 cm / 4 3/8"

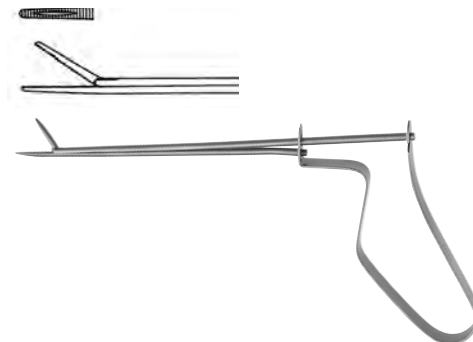

BUCK

034-412-110 11,0 cm / 4 3/8"

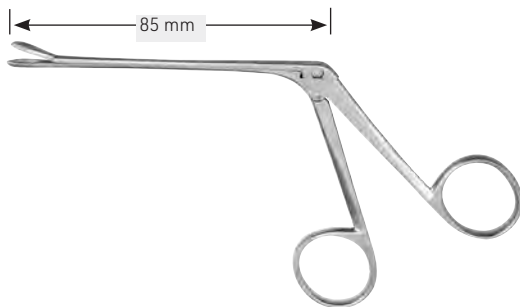
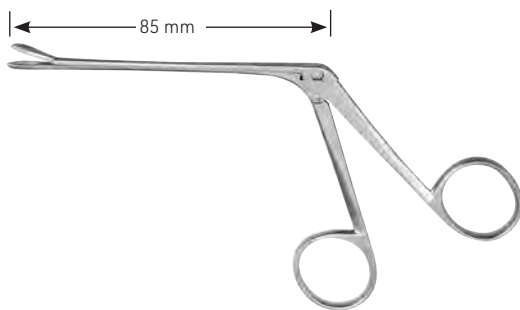

HARTMANN-WULLSTEIN

034-420-085 8,5 cm

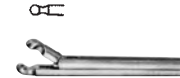

HARTMANN-WULLSTEIN

034-422-085 Ø 1,0 mm / 8,5 cm



HARTMANN

034-424-085 8,5 cm



HARTMANN

034-426-085 8,5 cm

HARTMANN

034-424-140 14,0 cm / 5 1/2"

Schaftlänge 140 mm
 Shaft length 140 mm
 longitud del vástago 140 mm
 lunghezza del gambo 140 mm

HARTMANN

034-426-140 14,0 cm / 5 1/2"

Schaftlänge 140 mm
 Shaft length 140 mm
 longitud del vástago 140 mm
 lunghezza del gambo 140 mm

HARTMANN

034-424-160 16,0 cm / 6 1/4"

Schaftlänge 160 mm
 Shaft length 160 mm
 longitud del vástago 160 mm
 lunghezza del gambo 160 mm

ø 2,0 mm



HARTMANN

034-430-020 8,5 cm / 3 1/4"



STRÜMPEL

034-434-085 8,5 cm / 3 1/4"

ø 2,5 mm



034-430-025 8,5 cm / 3 1/4"

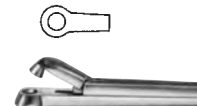

HARTMANN-HOFFMANN

034-438-085 8,5 cm / 3 1/4"

ø 3,0 mm



034-430-030 8,5 cm / 3 1/4"



034

Ohr-Knochenstanzen
Mastoid Rongeurs
Pinzas cortantes para huesos
Pinze osteomi



034-450-015 1,5 mm



034-450-020 2,0 mm



034-450-030 3,0 mm

CITELLI

034-450-015 - 034-450-030 17,0 cm / 6³/₄"



1 mm Schnitt
1 mm cut
corte 1 mm
taglio 1 mm

BEYER

034-452-001 14,0 cm / 5¹/₂"



2 mm Schnitt
2 mm cut
corte 2 mm
taglio 2 mm

BEYER

034-452-002 19,0 cm / 7¹/₂"

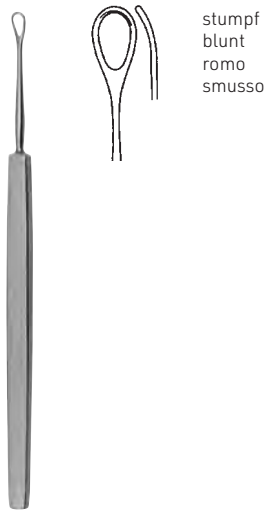

stumpf
 blunt
 romo
 smusso

LANGENBECK
 034-501-130 13,0 cm / 5"



034-503-001



034-503-002

SHAPLEIGH
 034-503-001 - 034-503-002 15,0 cm / 6"



gerade stumpf
 straight blunt
 recto romo
 retto smusso



FIG. 00
 034-510-002



FIG. 0
 034-510-010



FIG. 1
 034-510-011



FIG. 2
 034-510-012



FIG. 3
 034-510-013



FIG. 4
 034-510-014



FIG. 5
 034-510-015



FIG. 00
 034-512-002



FIG. 0
 034-512-010



FIG. 1
 034-512-011



FIG. 2
 034-512-012



FIG. 3
 034-512-013



FIG. 4
 034-512-014



FIG. 5
 034-512-015



gerade scharf
 straight sharp
 recto agudo
 retto acuto

BUCK
 034-510-002 - 034-512-015



034

Ohrküretten
Ear Curettes
Curetas auriculares
Curette auricolari



gebogen stumpf
curved blunt
curva romo
curvo smusso



FIG. 00
034-515-002



FIG. 0
034-515-010



FIG. 1
034-515-011



FIG. 2
034-515-012



FIG. 3
034-515-013



FIG. 4
034-515-014



FIG. 5
034-515-015



gebogen scharf
curved sharp
curva agudo
curvo acuto



FIG. 00
034-517-002



FIG. 0
034-517-010



FIG. 1
034-517-011



FIG. 2
034-517-012



FIG. 3
034-517-013



FIG. 4
034-517-014



FIG. 5
034-517-015



BUCK
034-515-002 - 034-517-015



JANSEN
034-521-150 15,0 cm / 6"

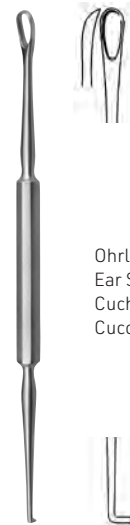

GROSS
034-523-120 12,0 cm / 4³/₄"

Ohrlöffel und Hähchen
Ear Scoop/Hook
Cucharilla/ganchito auricular
Cucchiaio auricolare

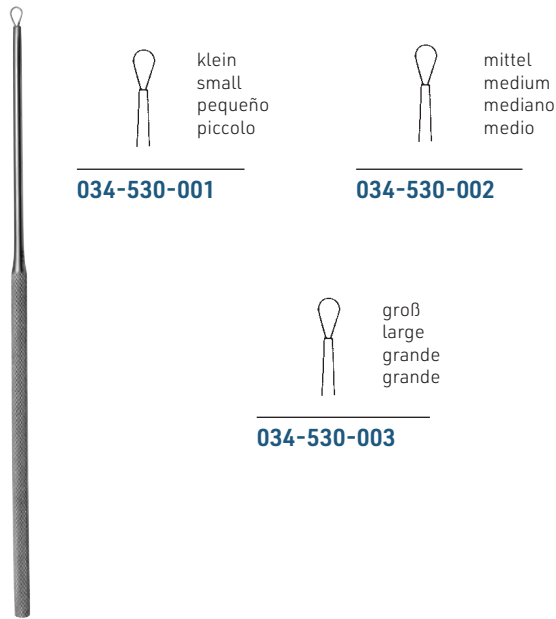

034-530-001

034-530-002

034-530-003

BILLEAU

034-530-001 - 034-530-003 16,0 cm / 6¹/₄"

Ohrschlinge
 Ear Loop
 Asa auricular
 Ansa auricolare

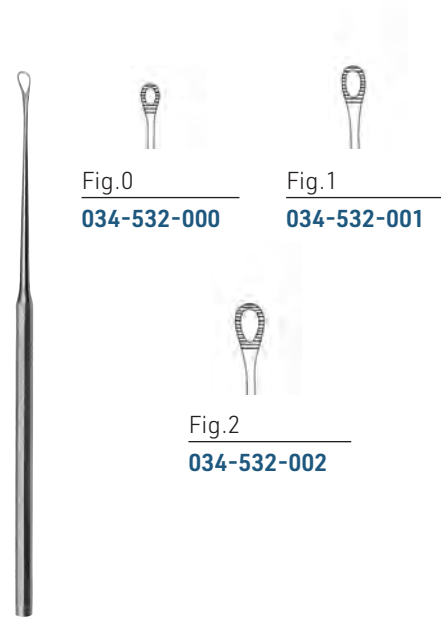

Fig.0
034-532-000

Fig.1
034-532-001

Fig.2
034-532-002

WEBER-LOCH

034-532-000 - 034-532-002 14,5 cm / 5³/₄"

Ohrschlinge
 Ear Loop
 Asa auricular
 Ansa auricolare

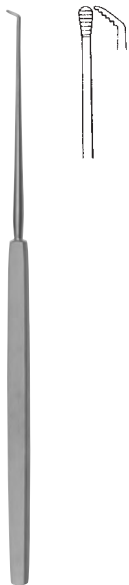

MOLDENHAUER

034-541-165 16,5 cm / 6¹/₂"

Fremdkörperhebel
 Foreign Body Lever
 Elevador para cuerpos extraños
 Leva per corpi estranei

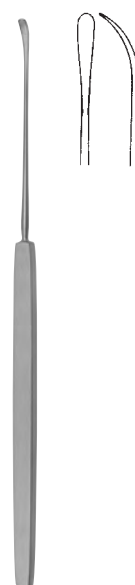

ZAUFAL

034-543-160 16,0 cm / 6¹/₂"

Fremdkörperhebel
 Foreign Body Lever
 Elevador para cuerpos extraños
 Leva per corpi estranei



HARTMANN

034-545-160 16,0 cm / 6"

Ohrhäkchen
 Ear Hooklet
 Ganchito auricular
 Uncino auricolare



034

Fremdkörperinstrumente, Ohrhäkchen
 Foreign Body Instruments, Ear Hooks
 Instrumentos para cuerpos extraños, Ganchitos auriculares
 Strumenti per corpi estranei, Uncini auricolare

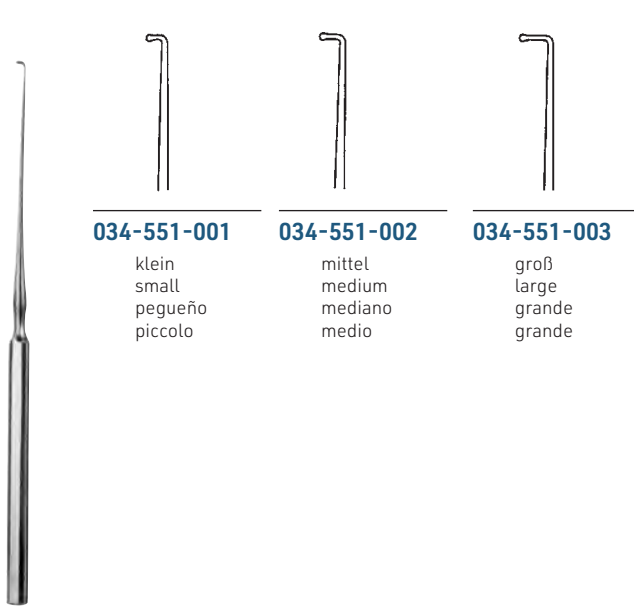

034-551-001

klein
 small
 pequeño
 piccolo

034-551-002

mittel
 medium
 mediano
 medio

034-551-003

groß
 large
 grande
 grande

LUCAE

034-551-001 - 034-551-003

14,0 cm / 5 1/2"

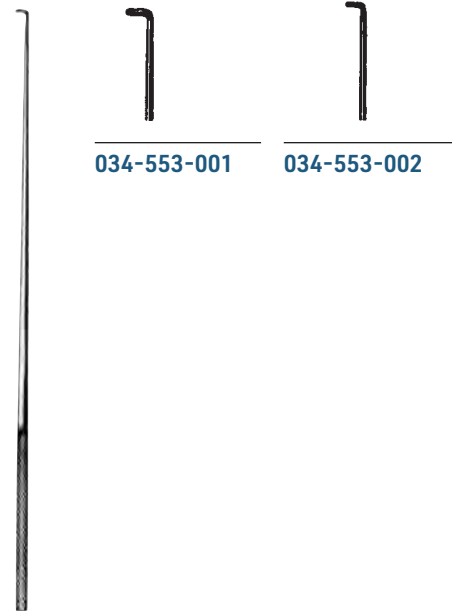

034-553-001

034-553-002

DAY

034-553-001 - 034-553-002

16,0 cm / 6 3/4"

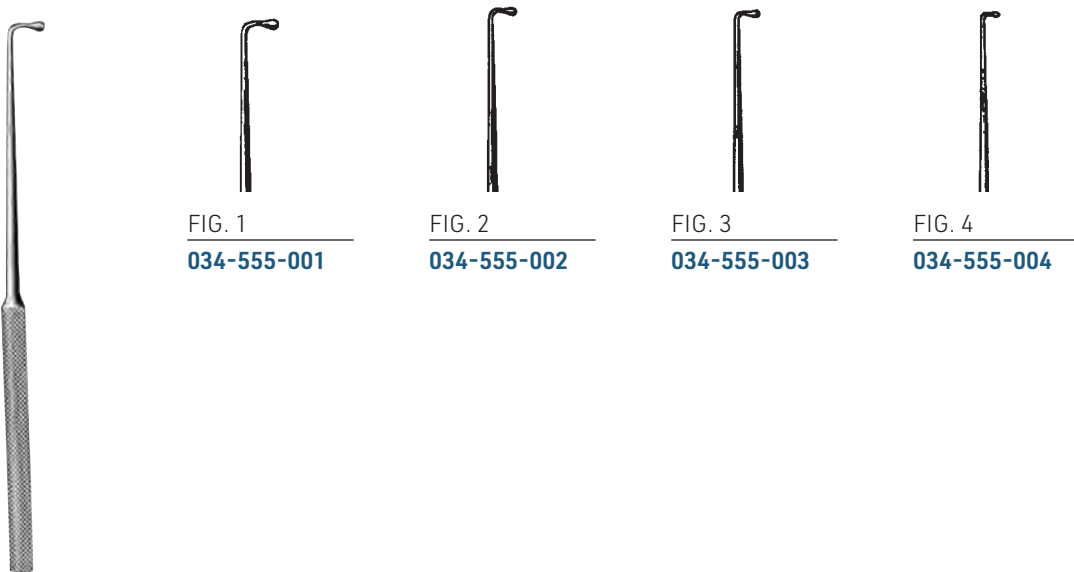

FIG. 1

034-555-001

FIG. 2

034-555-002

FIG. 3

034-555-003

FIG. 4

034-555-004

WAGNER

034-555-001 - 034-555-004

14,0 cm / 5 1/2"



POLITZER
034-561-160 16,0 cm / 6 1/2"



Nadel quergestellt
 needle horizontally
 aguja en posición horizontal
 ago orizzontale

POLITZER
034-563-160 16,0 cm / 6 1/4"



POLITZER
034-565-150 15,0 cm / 6"
 Furunkelmesser
 Furuncle Knife
 cuchillo para furúnculos
 Coltello per foruncoli



POLITZER
034-566-180 18,0 cm / 7"



LUCAE
034-571-180 18,0 cm / 7"



LUCAE
034-573-180 18,0 cm / 7"



034

Ohrraspatorien, Ohrlöffel
 Ear Periosteal Elevators, Ear Scoops
 Legras auriculares, Cucharillas auriculares
 Raspatori auricolari, Curette auricolari



LEMPERT
034-581-205 20,5 cm / 8"



LEMPERT
034-583-180 18,0 cm / 7"

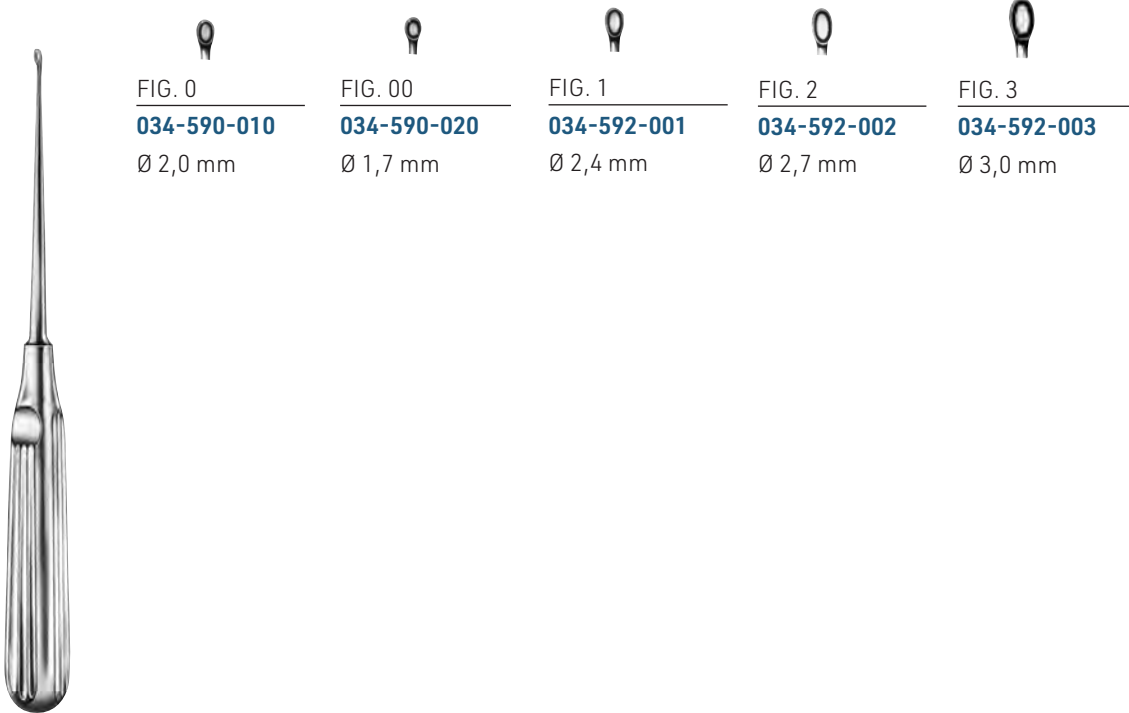

FIG. 0
034-590-010
 Ø 2,0 mm

FIG. 00
034-590-020
 Ø 1,7 mm

FIG. 1
034-592-001
 Ø 2,4 mm

FIG. 2
034-592-002
 Ø 2,7 mm

FIG. 3
034-592-003
 Ø 3,0 mm

LEMPERT
034-590-010 - 034-592-003 20,0 cm / 8"



UNIVERSAL

034-620-000

Komplett mit beweglicher Düse, Nasenolive, Schraubflasche und Gebläse
Complete with moveable tube, Nose Olive, screw bottle and rubber bulb
Completo con tubo mòvil, oliva nasal, botella con rosca y pera de goma
Completo con tubo mobile, oliva nasale, bottiglia con filettatura e pera di gomma



034

Ohrspritzen
Ear Syringes
Jeringas auriculares
Siringhe auricolari



034-640-050 50 ml

komplett mit Teller und 2 Ansätzen
complete with protection disc and 2 tips
completo con disco protector y 2 puntas
completo con disco protettivo e 2 punte

034-640-075 75 ml

komplett mit Teller und 2 Ansätzen
complete with protection disc and 2 tips
completo con disco protector y 2 puntas
completo con disco protettivo e 2 punte

034-640-100 100 ml

komplett mit Teller und 2 Ansätzen
complete with protection disc and 2 tips
completo con disco protector y 2 puntas
completo con disco protettivo e 2 punte

034-640-150 150 ml

komplett mit Teller und 2 Ansätzen
complete with protection disc and 2 tips
completo con disco protector y 2 puntas
completo con disco protettivo e 2 punte



035

Rhinologie
Rhinology
Rinología
Rinologia



035

Nasenspekula
Nasal Specula
Espèculos nasales
Specoli nasali



GOLDSMITH (THUDICHUM)

035-100-001 - 035-100-003 6,5 cm / 2 1/2"



Fig.1

035-100-001 21,0 x 9,5 mm



Fig.2

035-100-002 21,0 x 10,5 mm

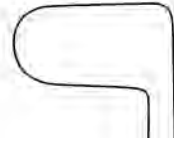

Fig.3

035-100-003 21,0 x 11,5 mm



HARTMANN-HALLE

035-110-001 - 035-110-003 15,0 cm / 6"



FIG. 1

035-110-001

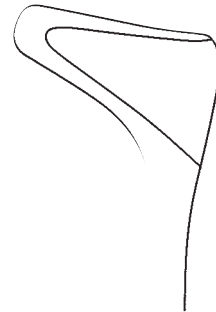

FIG. 2

035-110-002

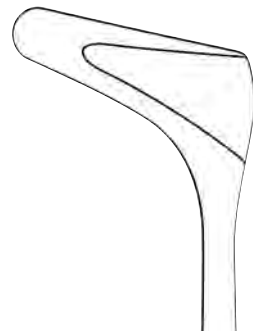

FIG. 3

035-110-003

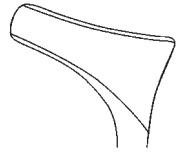

Fig.1
035-120-001

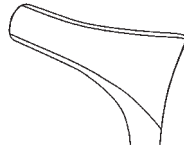

Fig.2
035-120-002

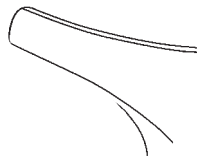

Fig.3
035-120-003

HARTMANN

035-120-001 - 035-120-003 15,0 cm / 6"



Fig.1
035-130-001



Fig.2



Fig.3
035-130-003

MOD. WIEN

035-130-001 - 035-130-003 14,5 cm / 5 1/4"



leichtes Modell
 lightweight
 mod. ligero
 mod. leggero

MOD. WIEN

035-132-135 13,5 cm / 5 1/4"



Fig.1
035-140-001



Fig.2
035-140-002

TIECK-HALLE

035-140-001 - 035-140-002 13,0 cm / 5 1/8"



035

Nasenspekula
Nasal Specula
Espèculos nasales
Specoli nasali

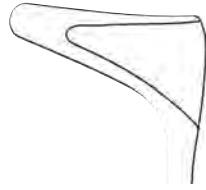

FIG. 1
035-150-001 35 mm

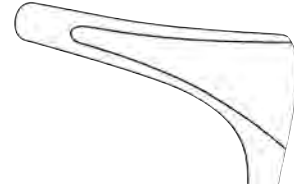

FIG. 2
035-150-002 50 mm

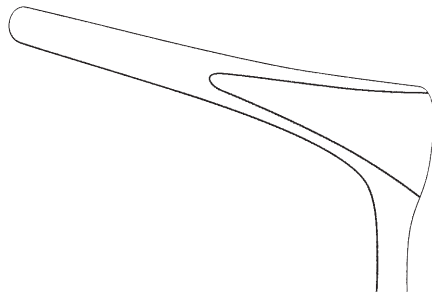

FIG. 3
035-150-003 75 mm

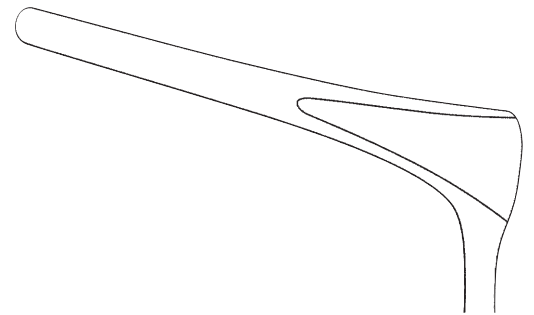

FIG. 4
035-150-004 90 mm

KILIAN

035-150-001 - 035-150-003 13,0 cm / 5 1/8"

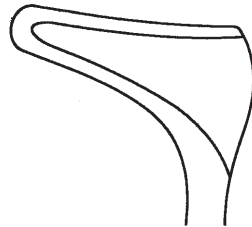

FIG. 1
035-160-001 35 mm

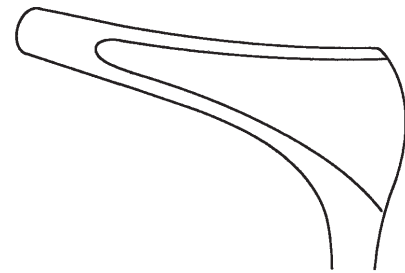

FIG. 2
035-160-002 50 mm

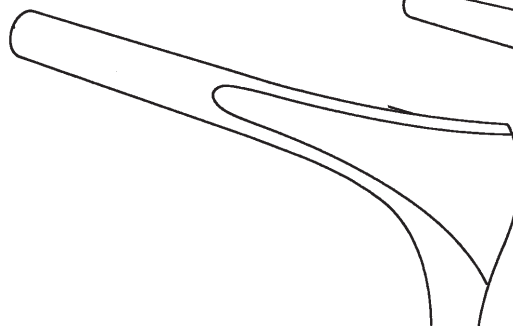

FIG. 3
035-160-003 75 mm

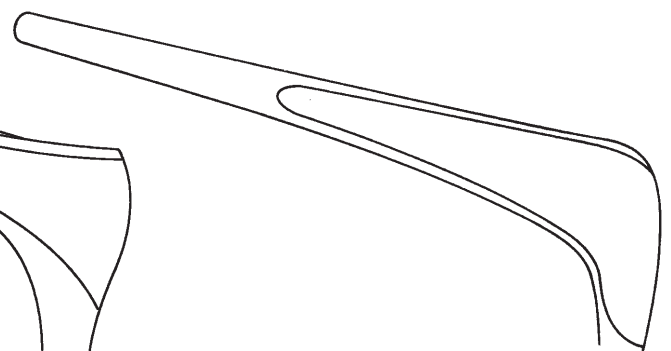

FIG. 4
035-160-004 90 mm

COTTLE

035-160-001 - 035-160-004 13,5 cm / 5 1/4"



BECKMANN Fig.1
035-164-001 13,0 cm / 5 1/8"



BECKMANN Fig.2
035-164-002 14,0 cm / 5"

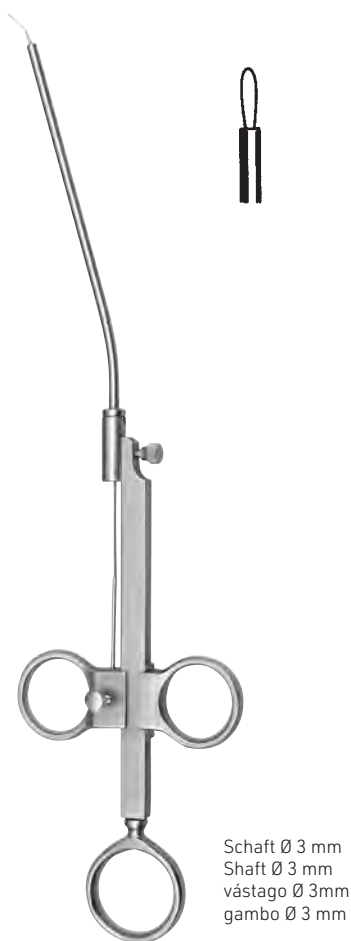

KRAUSE
035-171-260 26,0 cm / 10 1/4"

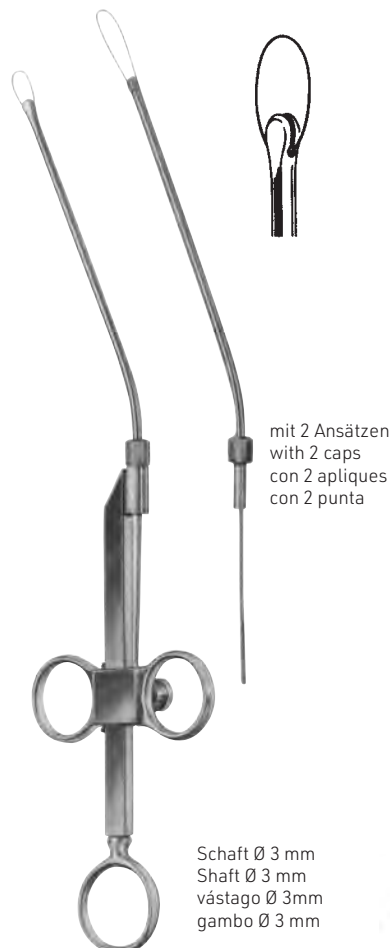

KRAUSE-VOSS
035-173-260 26,0 cm / 10 1/4"

mit 2 Ansätzen
 with 2 caps
 con 2 appliques
 con 2 punta

Schnürschlingen Ø 0,30 mm
 Bündel mit 12 Stück
 Snare loops Ø 0,30 mm
 Bundle with 12 pieces
 Asas de alambre Ø 0,30 mm
 Manajo de 12 piezas
 Lacci di filo di metallo Ø 0,30 mm
 Manello di 12 pezzi



035-175-003 10,0 cm



035

Nasentamponpinzetten, Nasenpolypenzangen
Nasal Tampon Forceps, Nasal Polypus Forceps
Pinzas para taponamiento, Pinzas para pólipos nasales
Pinze per medicature, Pinze per polipi nasali



TRÖLTSCH
035-181-150 15,0 cm / 6"



TRÖLTSCH
035-181-180 18,0 cm / 7"



JANSEN (GRÜNWALD)
035-185-180 18,0 cm / 7"
035-185-200 20,0 cm / 8"



WESTMACOTT
035-201-200 20,0 cm / 8"

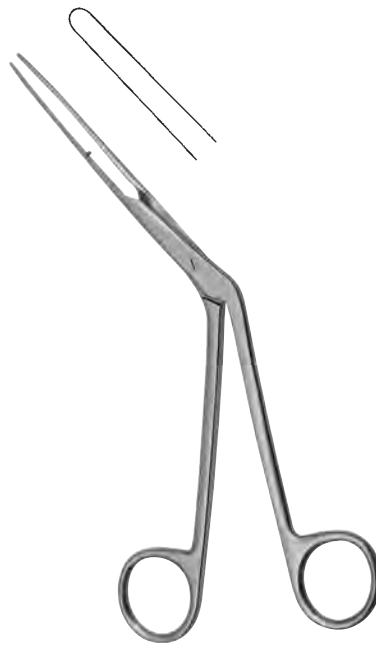

LUBET-BARBON
035-203-185 18,5 cm / 7 1/4"



HARTMANN
035-205-160 16,0 cm / 6 1/4"



HARTMANN
 035-207-200 20,0 cm / 8"

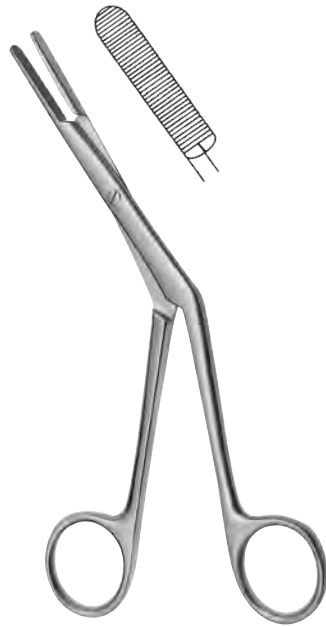

KILLIAN
 035-209-170 17,0 cm / 6³/₄"



HEYMANN
 035-221-180 18,0 cm / 7"

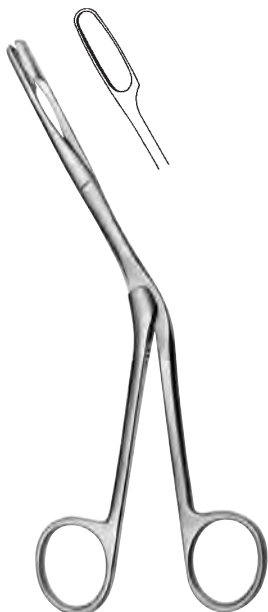

KNIGHT
 035-223-180 18,0 cm / 7"

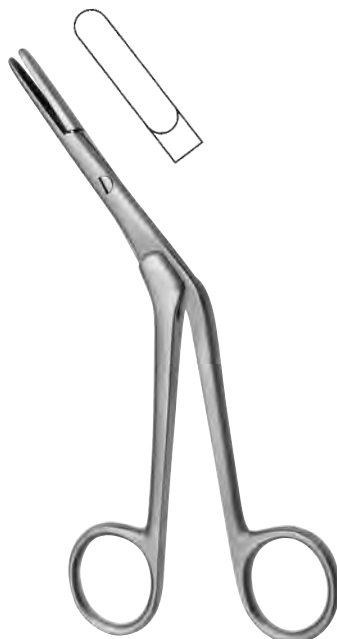

CRAIG
 035-225-160 16,0 cm / 6¹/₄"



035-229-001
 links gebogen
 left curved
 curva por izquierda
 curva a sinistra



035-229-002
 rechts gebogen
 right curved
 curva por derecha
 curva a destra

035-229-001 - 035-229-002 16,0 cm / 6¹/₄"



035

Septumzangen, scharfe Nasenzangen
 Septum Forceps, Nasal Cutting Forceps
 Pinzas para tabique nasal, Pinzas nasales cortantes
 Pinze per il setto nasale, Pinze nasale taglienti per il naso

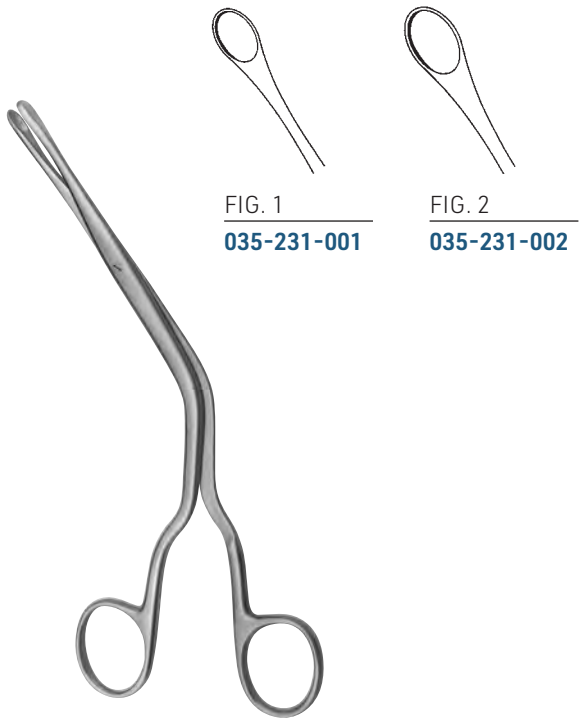

FIG. 1
035-231-001

FIG. 2
035-231-002

LUC
035-231-001 - 035-231-002 20,0 cm / 8"

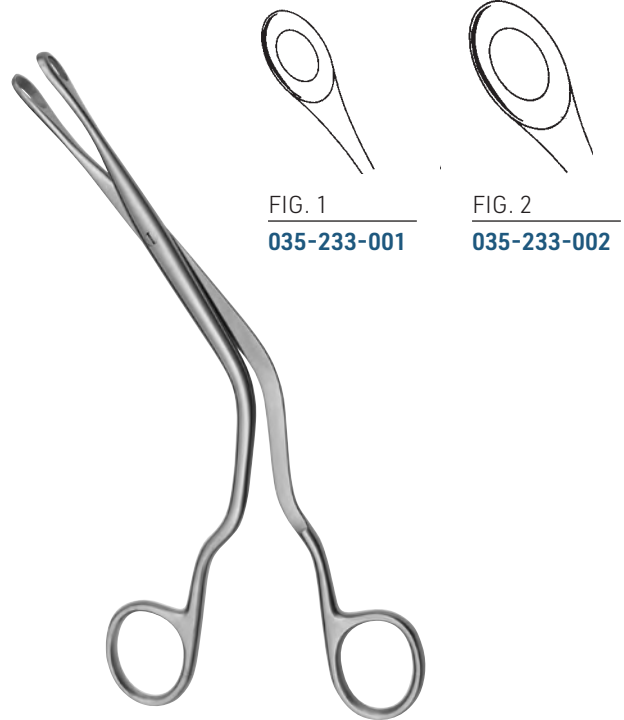

FIG. 1
035-233-001

FIG. 2
035-233-002

LUC
035-233-001 - 035-233-002 19,0 cm / 7½"



FIG. 1
035-235-001

FIG. 2
035-235-002

FIG. 3
035-235-003

FIG. 4
035-235-004

BRUENINGS
035-235-001 - 035-235-004 19,0 cm / 7½"

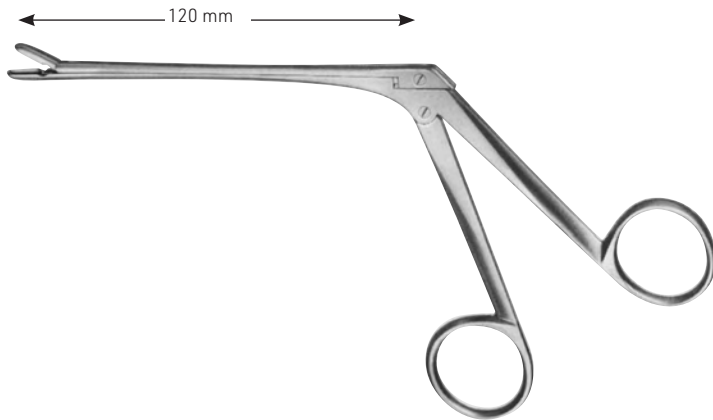

3 x 8 mm



035-240-190

gerade
 straight
 recto
 retto

3 x 8 mm



035-241-190

aufgebogen
 bent upwards
 curva por arriba
 curva in alto

TAKAHASHI

035-240-190 - 035-241-190

19,0 cm / 7 1/2"

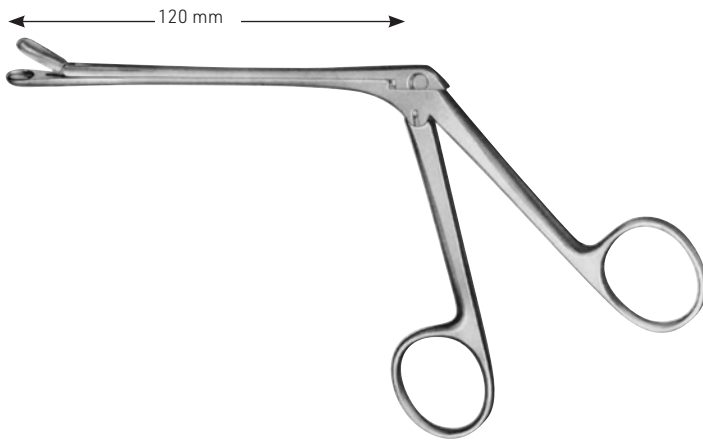

WATSON-WILLIAMS

035-243-190

gerade
 straight
 recto
 retto



035-245-190

gerade
 straight
 recto
 retto

035-243-190 - 035-245-190

19,0 cm / 7 1/2"

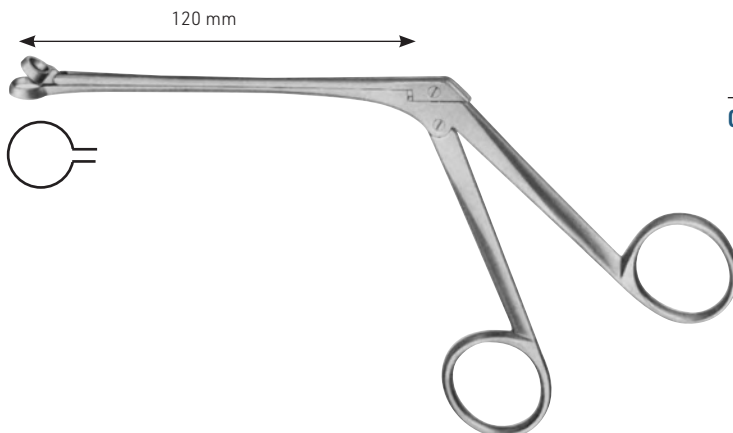

035-251-005 Ø 5 mm



035-251-007 Ø 7 mm



035-251-009 Ø 9 mm



035-251-011 Ø 11 mm

HARTMANN

035-251-005 - 035-251-011

19,0 cm / 7 1/2"



SCHMEDEN

035-253-190

19,0 cm / 7 1/2"

Maulbreite 8,0 mm
 jaw width 8,0 mm
 anchura de la boca 8,0 mm
 larghezza della bocca 8,0 mm



035

Scharfe Nasenzangen
Nasal Cutting Forceps
Pinzas nasales cortantes
Pinze taglienti per il naso

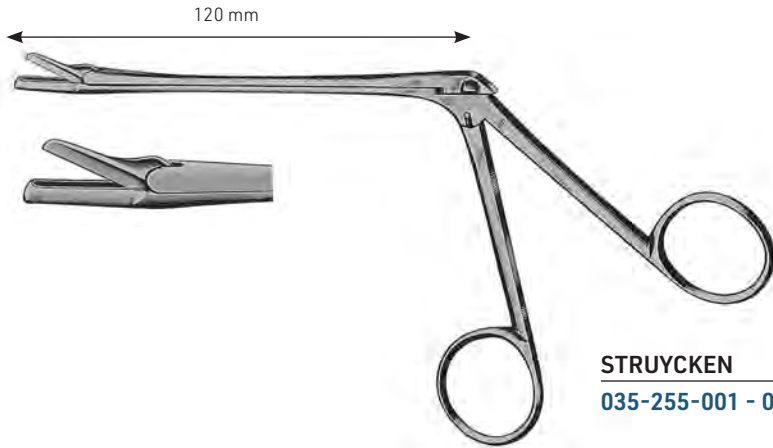

STRUYCKEN

035-255-001 - 035-255-002 19,0 cm / 7 1/2"

FIG. 1

035-255-001
Maulbreite 1,0 mm
jaw width 1,0 mm
anchura de la boca 1,0 mm
larghezza della bocca 1,0 mm

FIG. 2

035-255-002
Maulbreite 1,5 mm
jaw width 1,5 mm
anchura de la boca 1,5 mm
larghezza della bocca 1,5 mm

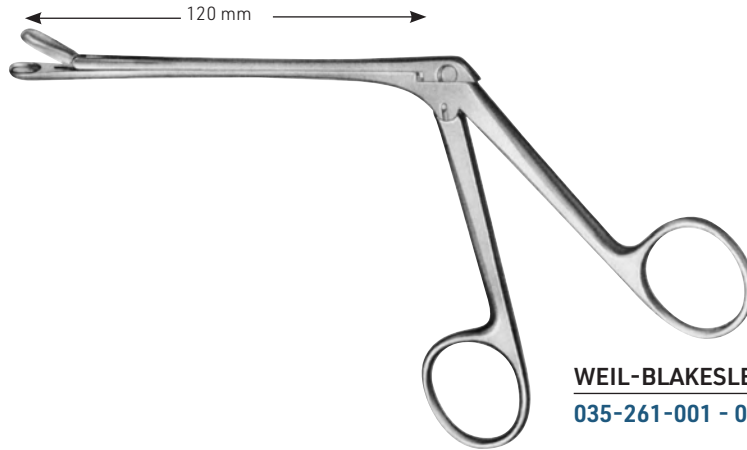

WEIL-BLAKESLEY

035-261-001 - 035-262-005 19,0 cm / 7 1/2"



FIG. 1

035-261-001
Maulbreite 3,0 mm
jaw width 3,0 mm
anchura de la boca 3,0 mm
larghezza della bocca 3,0 mm



FIG. 2

035-261-002
Maulbreite 3,5 mm
jaw width 3,5 mm
anchura de la boca 3,5 mm
larghezza della bocca 3,5 mm



FIG. 3

035-261-003
Maulbreite 4,5 mm
jaw width 4,5 mm
anchura de la boca 4,5 mm
larghezza della bocca 4,5 mm



FIG. 4

035-261-004
Maulbreite 5,0 mm
jaw width 5,0 mm
anchura de la boca 5,0 mm
larghezza della bocca 5,0 mm



FIG. 5

035-261-005
Maulbreite 5,5 mm
jaw width 5,5 mm
anchura de la boca 5,5 mm
larghezza della bocca 5,5 mm



mit Hals
with neck
con cuello
con collo



FIG. 1

035-262-001
Maulbreite 3,0 mm
jaw width 3,0 mm
anchura de la boca 3,0 mm
larghezza della bocca 3,0 mm



FIG. 2

035-262-002
Maulbreite 3,5 mm
jaw width 3,5 mm
anchura de la boca 3,5 mm
larghezza della bocca 3,5 mm



FIG. 3

035-262-003
Maulbreite 4,5 mm
jaw width 4,5 mm
anchura de la boca 4,5 mm
larghezza della bocca 4,5 mm



FIG. 4

035-262-004
Maulbreite 5,0 mm
jaw width 5,0 mm
anchura de la boca 5,0 mm
larghezza della bocca 5,0 mm



FIG. 5

035-262-005
Maulbreite 5,5 mm
jaw width 5,5 mm
anchura de la boca 5,5 mm
larghezza della bocca 5,5 mm

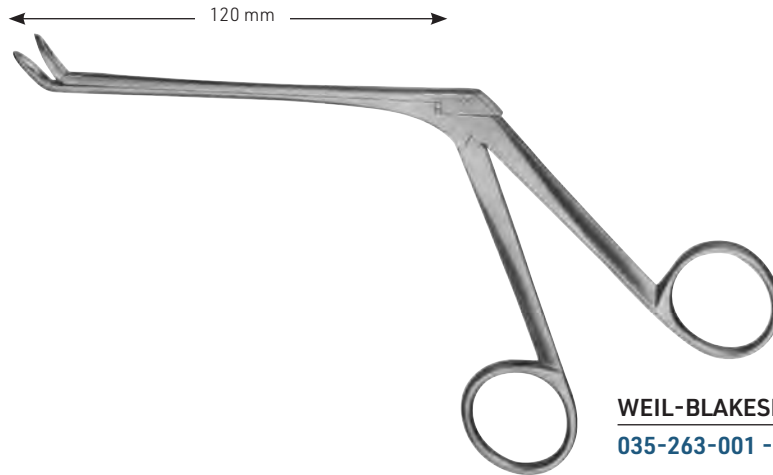

WEIL-BLAKESLEY

035-263-001 - 035-263-004

19,0 cm / 7 1/2"

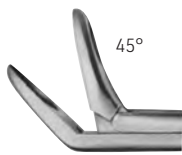

FIG. 1

035-263-001

Maulbreite 3,0 mm
 jaw width 3,0 mm
 anchura de la boca 3,0 mm
 larghezza della bocca 3,0 mm



FIG. 2

035-263-002

Maulbreite 3,5 mm
 jaw width 3,5 mm
 anchura de la boca 3,5 mm
 larghezza della bocca 3,5 mm



FIG. 3

035-263-003

Maulbreite 4,5 mm
 jaw width 4,5 mm
 anchura de la boca 4,5 mm
 larghezza della bocca 4,5 mm



FIG. 4

035-263-004

Maulbreite 5,0 mm
 jaw width 5,0 mm
 anchura de la boca 5,0 mm
 larghezza della bocca 5,0 mm

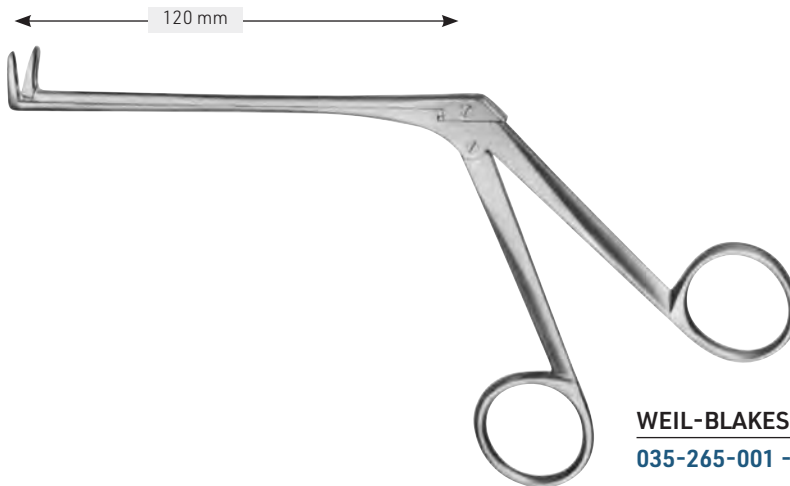

WEIL-BLAKESLEY

035-265-001 - 035-265-004

19,0 cm / 7 1/2"

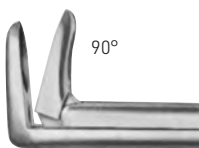

FIG. 1

035-265-001

Maulbreite 3,0 mm
 jaw width 3,0 mm
 anchura de la boca 3,0 mm
 larghezza della bocca 3,0 mm



FIG. 2

035-265-002

Maulbreite 3,5 mm
 jaw width 3,5 mm
 anchura de la boca 3,5 mm
 larghezza della bocca 3,5 mm



FIG. 3

035-265-003

Maulbreite 4,5 mm
 jaw width 4,5 mm
 anchura de la boca 4,5 mm
 larghezza della bocca 4,5 mm



FIG. 4

035-265-004

Maulbreite 5,0 mm
 jaw width 5,0 mm
 anchura de la boca 5,0 mm
 larghezza della bocca 5,0 mm



035

Scharfe Nasenzangen
 Nasal Cutting Forceps
 Pinzas nasales cortantes
 Pinze taglienti per il naso

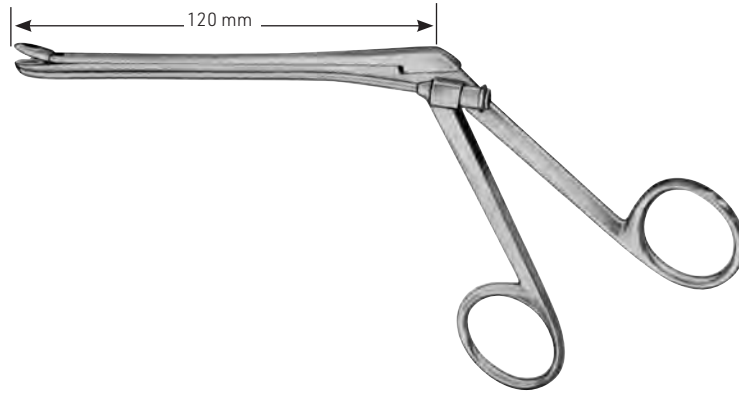

WEIL-BLAKESLEY

035-271-001 - 035-279-003

19,0 cm / 7 1/2"

gerade
 straight
 recta
 retta



035-271-001 2,5 mm



035-271-002 3,6 mm



035-271-003 4,8 mm

45° aufgebogen
 45° up curved
 45° curva arriba
 45° curva in alto

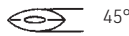

035-273-001 2,5 mm



035-273-002 3,6 mm



035-273-003 4,8 mm

90° aufgebogen
 90° up curved
 90° curva arriba
 90° curva in alto



035-275-001 2,5 mm



035-275-002 3,6 mm



035-275-003 4,8 mm

rechts gebogen
 right curved
 curva por derecha
 curva a destra



035-277-001 2,5 mm



035-277-002 3,6 mm



035-277-003 4,8 mm

links gebogen
 left curved
 curva por izquierda
 curva a sinistra



035-279-001 2,5 mm



035-279-002 3,6 mm



035-279-003 4,8 mm

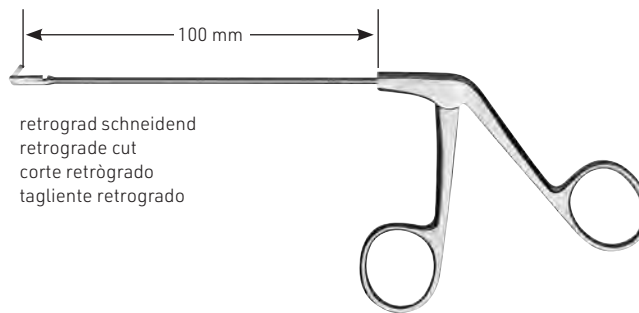

retrograd schneidend
 retrograde cut
 corte retrògrado
 tagliente retrogrado

STAMMBERGER

035-291-001 - 035-291-003

Antrumstanze
 Antrum Punch
 Pinza saca-bocado para seno maxilar
 Pinza tagliente per seno mascellare

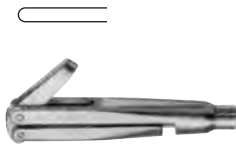

035-291-001 2 mm
 oben schneidend
 up cutting
 cortante por arriba
 tagliente in alto



035-291-002 2 mm
 rechts schneidend
 righ cutting
 cortante a la derecha
 tagliente a destra



035-291-003 2 mm
 links schneidend
 left cutting
 cortante a la izquierda
 tagliente a sinistra

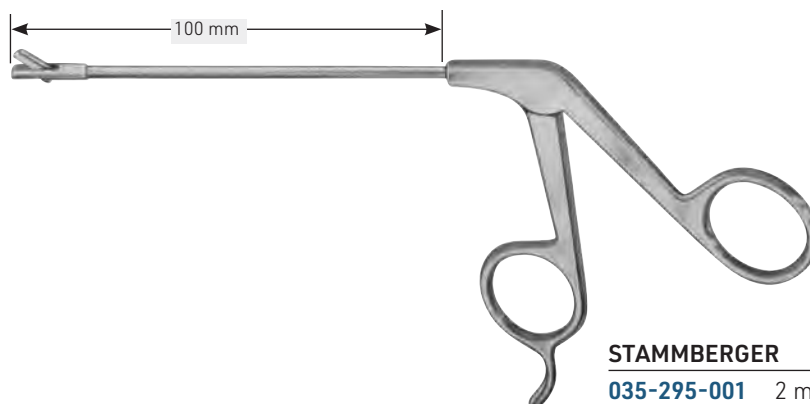

STAMMBERGER

035-295-001 2 mm



035

Nasenscheren
Nasal scissors
Tijeras nasales
Forbici nasale

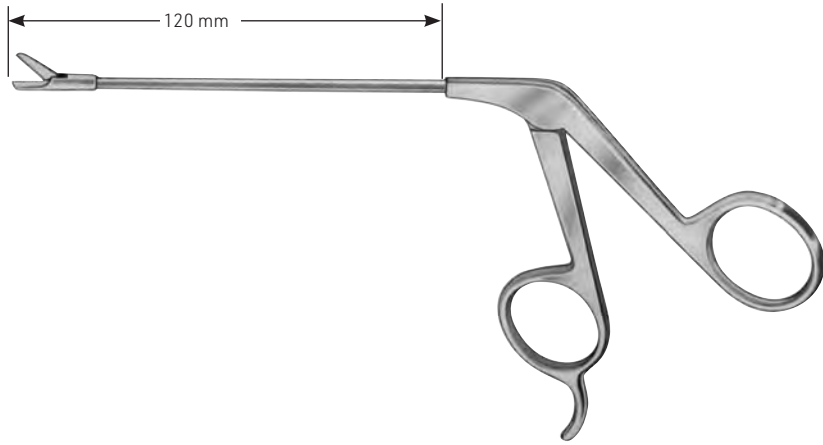

035-301-001 - 035-301-003



035-301-001 Ø 5 mm

gerade schneidend
straight cutting
cortante recto
tagliente retto

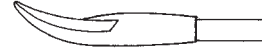

035-301-002 Ø 5 mm

rechts gebogen schneidend
right curved cutting
cortante curva derecha
tagliente curva destra

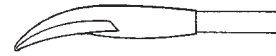

035-301-003 Ø 5 mm

links gebogen schneidend
left curved cutting
cortante curva izquierda
tagliente curva sinistra

MICRO

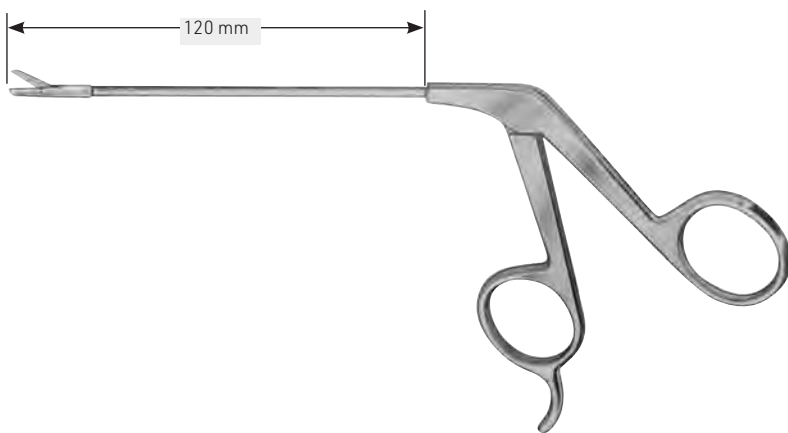

035-305-001 - 035-305-003



035-305-001 Ø 3,5 mm

gerade schneidend
straight cutting
cortante recto
tagliente retto



035-305-002 Ø 3,5 mm

rechts gebogen schneidend
right curved cutting
cortante curva derecha
tagliente curva destra



035-305-003 Ø 3,5 mm

links gebogen schneidend
left curved cutting
cortante curva izquierda
tagliente curva sinistra

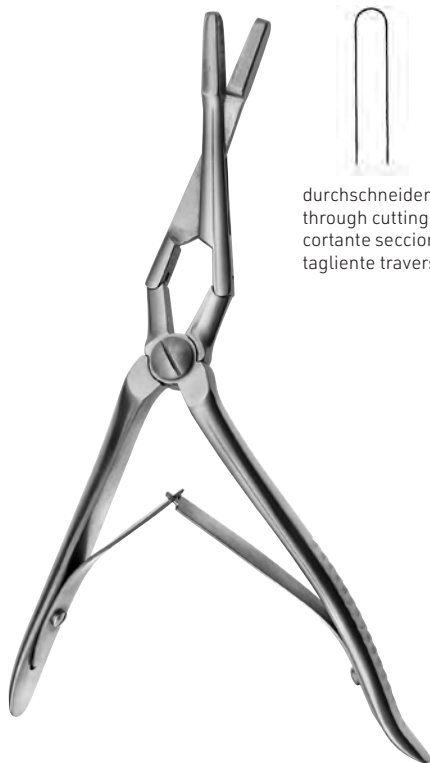

durchschneidend
 through cutting
 cortante seccional
 tagliente trasverso

MIDDLETON-JANSEN

035-321-190 19,0 cm / 7 1/2"



MIDDLETON-JANSEN

035-323-190 19,0 cm / 7 1/2"



eine Schneide gezahnt
 one toothed cutting edge
 una hoja dentada
 una lama dentata

CAPLAN

035-325-200 20,0 cm / 8"



035-328-001

Schutzkappe
 Protection Cap
 Caperuza protectora
 Calotta protettiva

RUBIN

035-327-210 21,0 cm / 8 1/4"



035

Keilbeinstanzen
Sphenoid Bone Punches
Pinzas sacabocadas para esfenoides
Pinze taglianti per seno sfenoidale

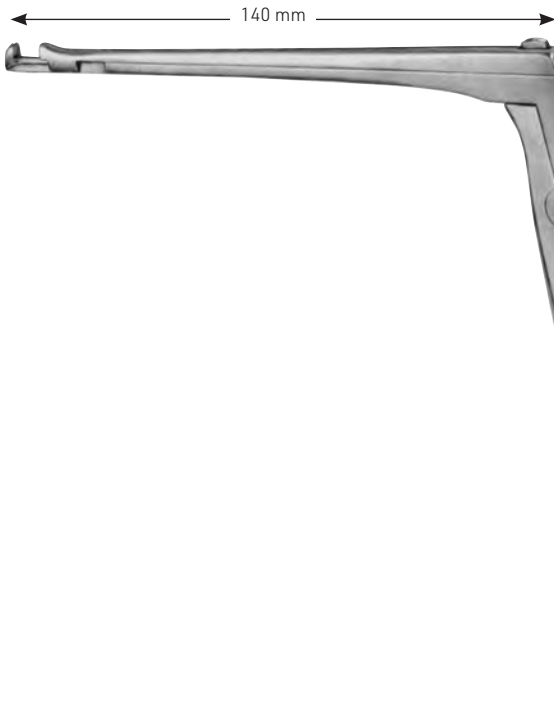

035-340-040

oben schneidend
up cutting
cortante por arriba
tagliante in alto



035-342-040

unten schneidend
down cutting
cortante por abajo
tagliante in basso

HAJEK

035-340-040 - 035-342-040

14,0 cm / 5 1/2"



035-344-035

oben schneidend
up cutting
cortante por arriba
tagliante in alto



035-346-035

unten schneidend
down cutting
cortante por abajo
tagliante in basso

HAJEK-KOFLER

035-344-035 - 035-346-035

14,0 cm / 5 1/2"

Antrumstanzen, Keilbeinstanzen
 Antrum Punches, Sphenoid Bone Punches
 Pinzas sacabocadas para seno maxilar, Pinzas sacabocadas para esfenoides
 Pinze taglienti per seno mascellare, Pinze taglienti per seno sfenoidale



035



3x3 mm



035-350-033

oben schneidend
 up cutting
 cortante por arriba
 tagliente in alto

4x4 mm



035-350-044

oben schneidend
 up cutting
 cortante por arriba
 tagliente in alto

5x5 mm



035-350-055

oben schneidend
 up cutting
 cortante por arriba
 tagliente in alto

6x6 mm



035-350-066

oben schneidend
 up cutting
 cortante por arriba
 tagliente in alto

KERRISON

035-350-033 - 035-350-066

17,0 cm / 6³/₄"



034-450-015 1,5 mm



034-450-020 2,0 mm



034-450-030 3,0 mm

CITELLI

034-450-015 - 034-450-030

17,0 cm / 6³/₄"



035

Rhinoplastik-Messer
Rhinoplastic Knives
Cuchillos para rinoplástica
Bisturi per plastica nasale

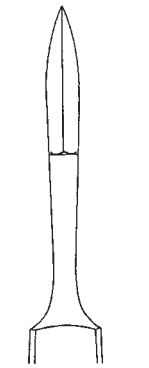

FIG. 1
035-400-160

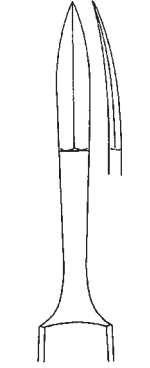

FIG. 2
035-401-160

JOSEPH

035-400-160 - 035-401-160 16,0 cm / 6 1/4"



FOMON

035-405-160 16,0 cm / 6 1/4"

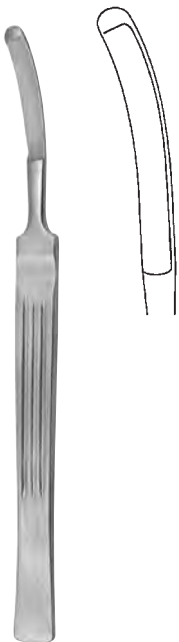

CONVERSE

035-407-160 16,0 cm / 6 1/4"



JOSEPH

035-408-150 15,0 cm / 6"

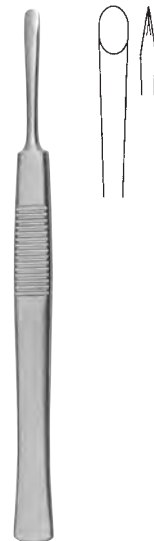

COTTLE

035-410-150 15,0 cm / 6"



Mukosamesser
Mucosa Knife
cuchillo para mucosa
Bisturi per mucosa

FREER

035-420-165 16,5 cm / 6 1/2"

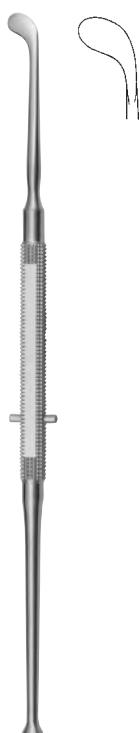

FREER

035-423-190 19,0 cm / 7 1/2"

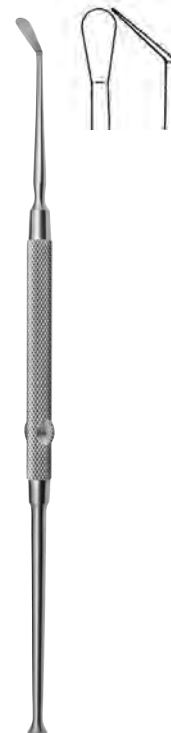

FREER

035-425-190 19,0 cm / 7 1/2"



035

Septummesser, Schwingmesser
Septum Knives, Swivel Knives
Cuchillos para tabique nasal
Bisturi per il setto nasale



035-430-003 3,0 mm



035-430-004 4,0 mm



035-430-005 5,0 mm

BALLENGER

035-430-003 - 035-430-005 21,0 cm / 8¹/₄"



035-431-003 3,0 mm



035-431-004 4,0 mm



035-431-005 5,0 mm

BALLENGER

035-431-003 - 035-431-005 21,0 cm / 8¹/₄"



Septummesser
 Septum Knife
 Cuchillo para tabique nasal
 Bisturi per il setto nasale

BRUENINGS

035-435-165 16,5 cm / 6 1/2"



4 mm



035-441-004

5 mm



035-441-005

MC KENTY

035-441-004 - 035-441-005 15,0 cm / 6"



3,5 mm



HALLE

035-443-160 16,0 cm / 6 1/4"

4 mm



JOSEPH

035-445-160 16,0 cm / 6 1/4"

5 mm



035-449-190

scharf
 sharp
 agudo
 acuto

6 mm



035-451-190

stumpf
 blunt
 romo
 smusso

FREER

035-449-190 - 035-451-190 19,0 cm / 7 1/2"



5 mm

scharf / stumpf
 sharp / blunt
 agudo / romo
 acuto / smusso

5 mm



FREER

035-455-180 18,0 cm / 7"



035

Septumelevatorien
Septum Elevators
Elevadores para tabique nasal
Elevatori per il setto nasale

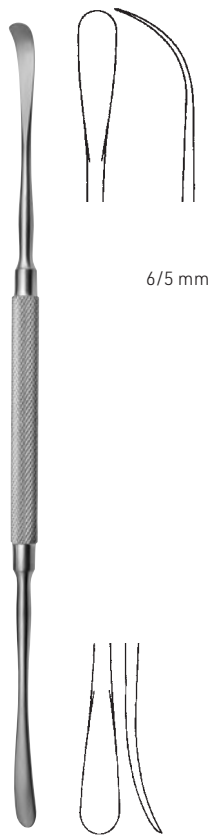

6/5 mm

FREER

035-457-205 20,5 cm / 8"



4 / 4 mm

MC KENTY

035-459-220 22,0 cm / 8³/₄"

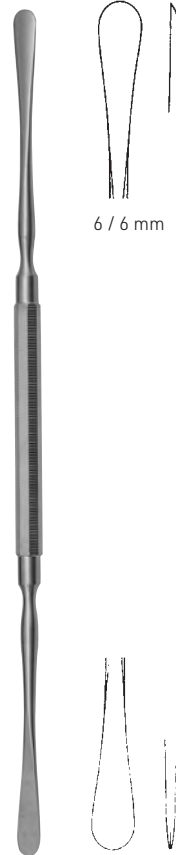

6 / 6 mm

BALLENGER-HAJEK

035-460-220 22,0 cm / 8³/₄"



5 / 5 mm

COTTLE

035-463-235 23,5 cm / 9¹/₄"

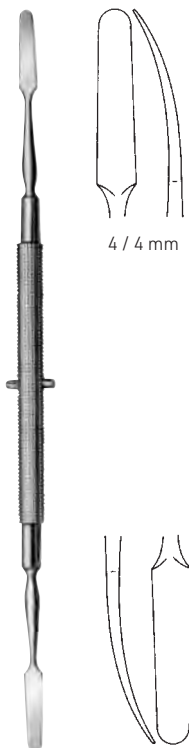

4 / 4 mm

KILIAN

035-465-180 18,0 cm / 7"

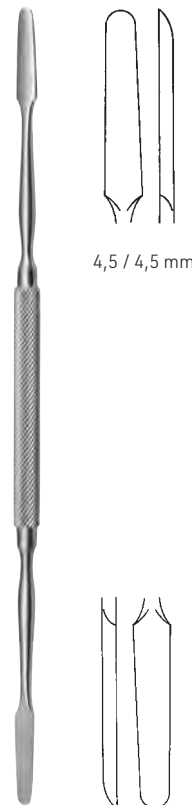

4,5 / 4,5 mm

KILIAN

035-468-220 22,0 cm / 8³/₄"

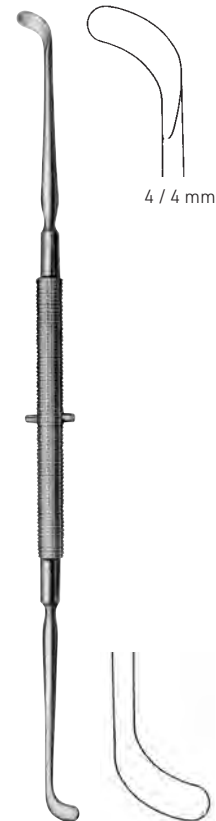

4 / 4 mm

PENNINGTON

035-469-215 21,5 cm / 7¹/₄"



4 / 4 mm

ROGER

035-481-195 19,5 cm / 7³/₄"



4 mm

JOSEPH-MASING

035-483-215 21,5 cm / 8¹/₂"

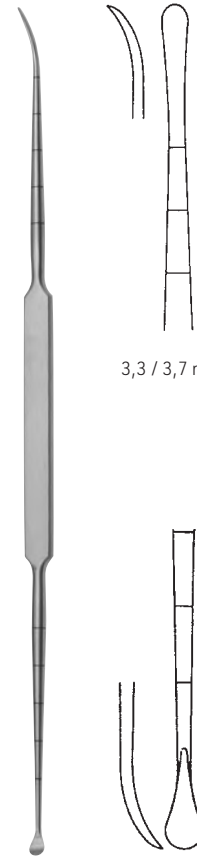

3,3 / 3,7 mm

COTTLE

035-485-220 22,0 cm / 8³/₄"

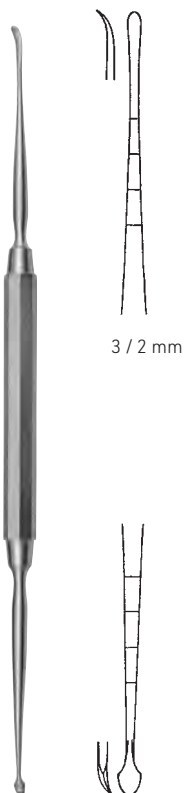

3 / 2 mm

MASING

035-487-210 21,0 cm / 8¹/₄"



4,5 / 4,5 mm

COTTLE

035-489-210 21,0 cm / 8¹/₄"

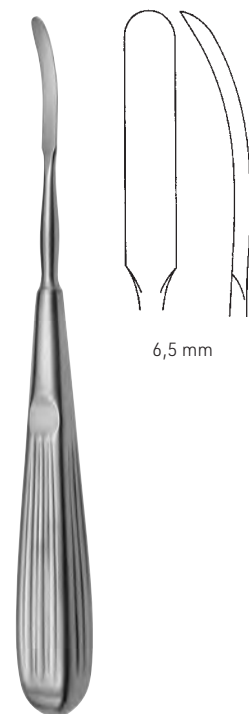

6,5 mm

JOSEPH

035-493-160 16,0 cm / 8¹/₄"



035

Septummeißel
Septum Chisels
Cinceles para tabique nasal
Scalpello per il setto nasale



FREER

035-500-160 16,0 cm / 6 1/4"



FREER

035-501-160 16,0 cm / 6 1/4"

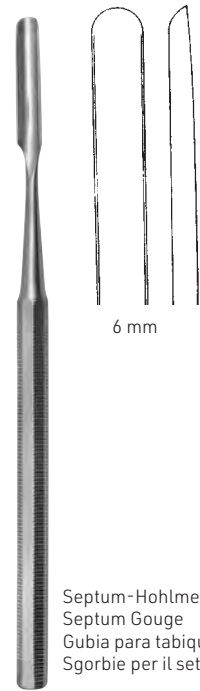

Septum-Hohlmeißel
Septum Gouge
Gubia para tabique nasal
Sgorbie per il setto nasale

FREER

035-510-150 15,0 cm / 6"

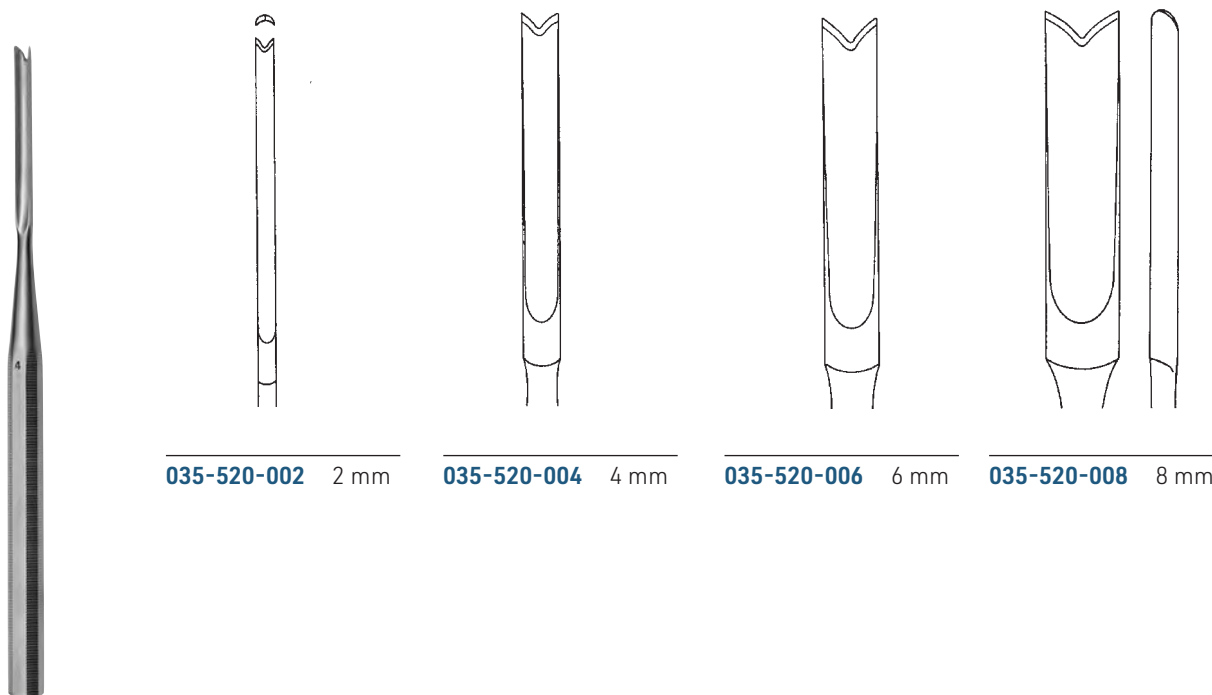

035-520-002 2 mm

035-520-004 4 mm

035-520-006 6 mm

035-520-008 8 mm

BALLENGER

035-520-002 - 035-520-008 15,0 cm / 6"

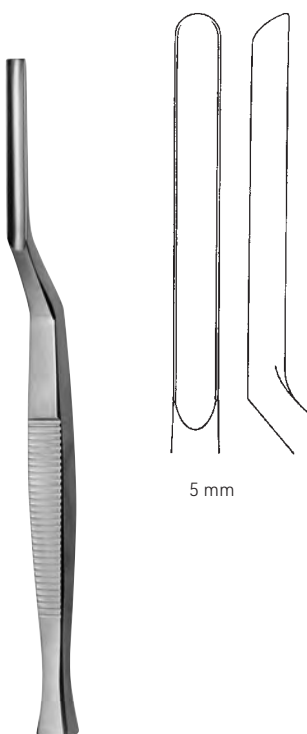

5 mm

KILLIAN

035-525-160 16,0 cm / 6 1/4"

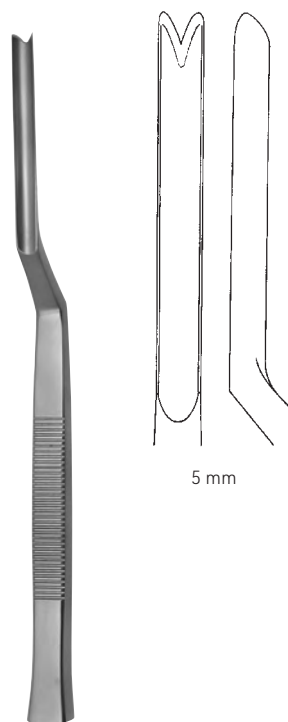

5 mm

KILLIAN

035-529-160 16,0 cm / 6 1/4"



035

Osteotome
Osteotomes
Osteótomos
Osteotomi



035-530-004 4 mm



035-530-007 7 mm



035-530-009 9 mm



035-530-012 12 mm

COTTLE

035-530-004 - 035-530-012 18,0 cm / 7"

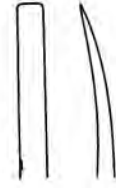

6 mm

COTTLE

035-535-006 18,0 cm / 7"



035-540-004 4 mm



035-540-007 7 mm



035-540-009 9 mm

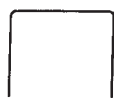

035-540-012 12 mm

COTTLE

035-540-004 - 035-540-012 18,0 cm / 7"



6 mm

COTTLE

035-543-006 18,0 cm / 7"

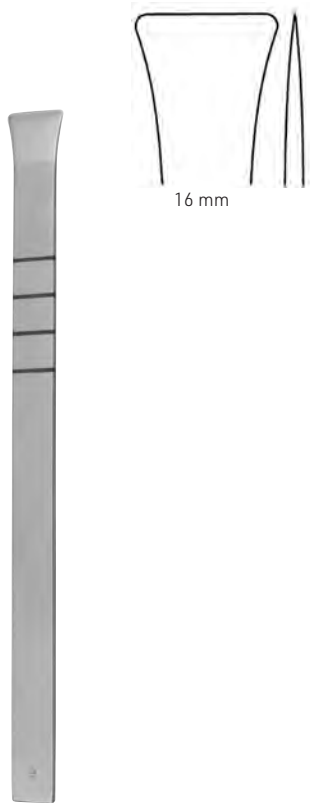

COTTLE
 035-546-016 18,0 cm / 7"

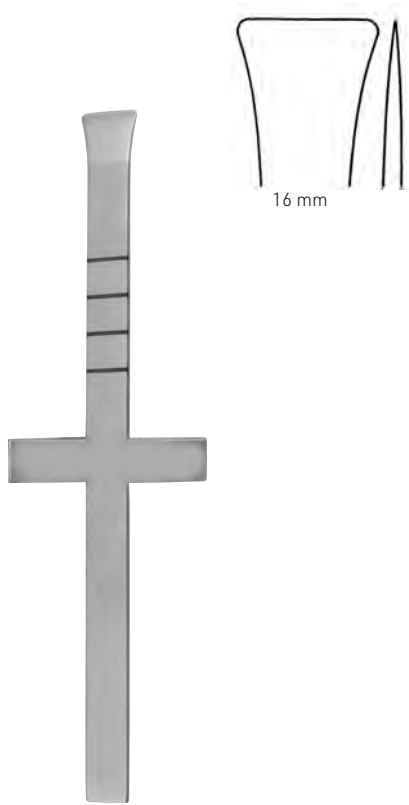

COTTLE
 035-548-016 18,0 cm / 7"

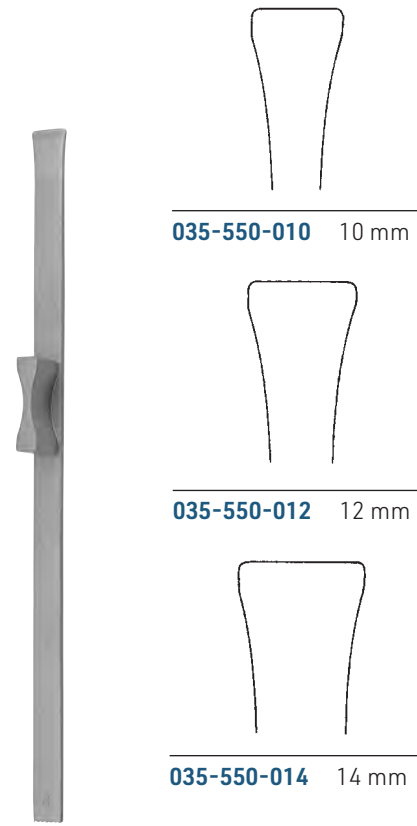

RUBIN
 035-550-010 - 035-550-014 18,0 cm / 7"

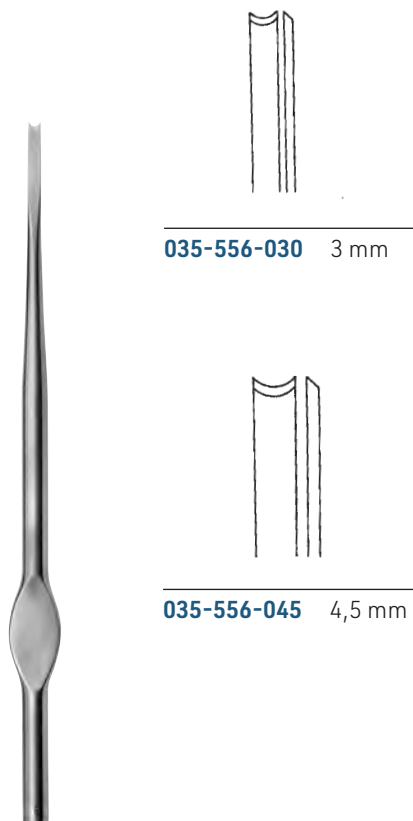

WALTER
 035-556-030 - 035-556-045 19,0 cm / 7 1/2"

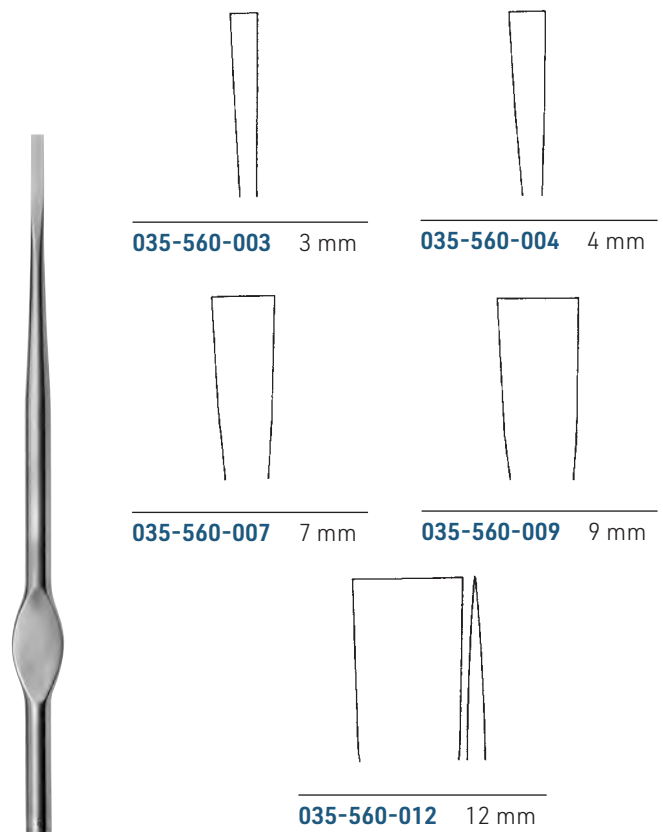

WALTER
 035-560-003 - 035-560-012 19,0 cm / 7 1/2"



035

Osteotome
Osteotomes
Osteótomos
Osteotomi

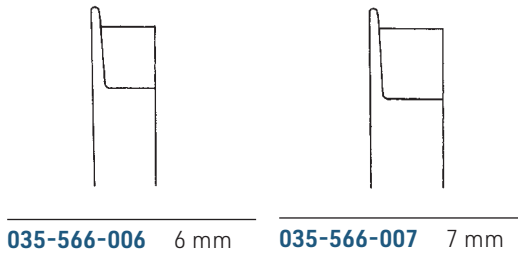
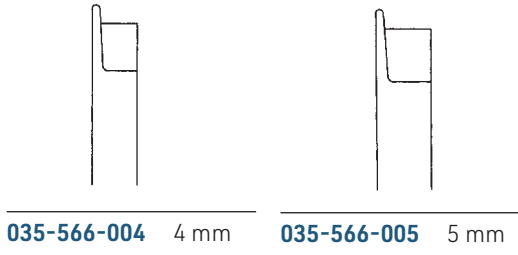

FOMON

035-566-004 - 035-566-007 16,0 cm / 6 1/4"

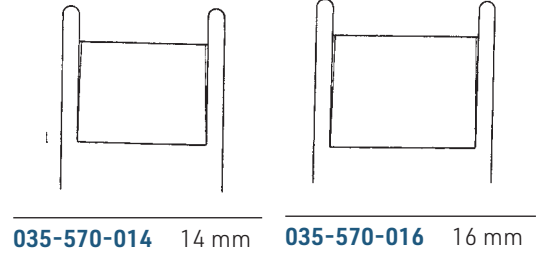
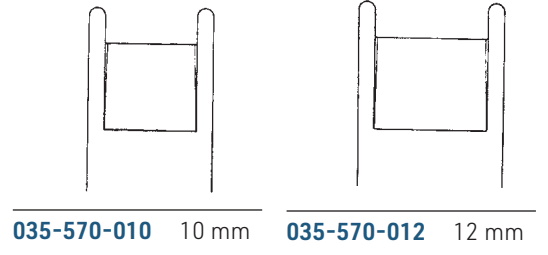

CINELLI

035-570-010 - 035-570-016 16,0 cm / 6 1/4"

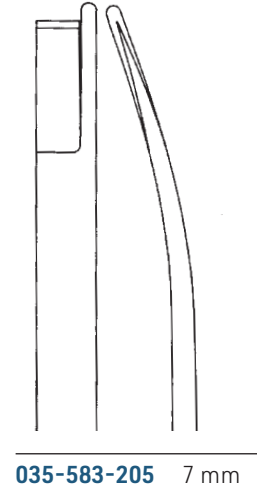
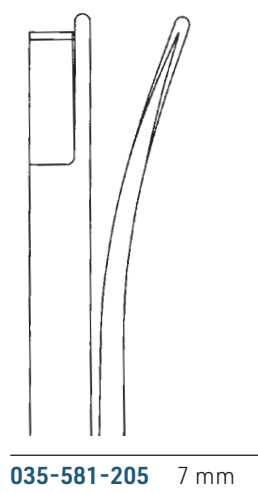
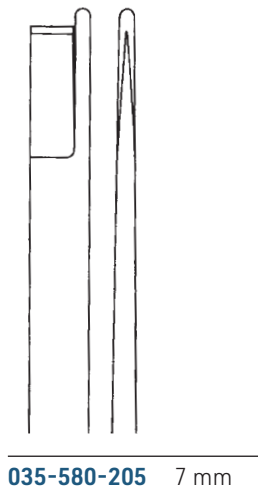

NEIVERT-ANDERSON

035-580-205 - 035-583-205 20,5 cm / 8"

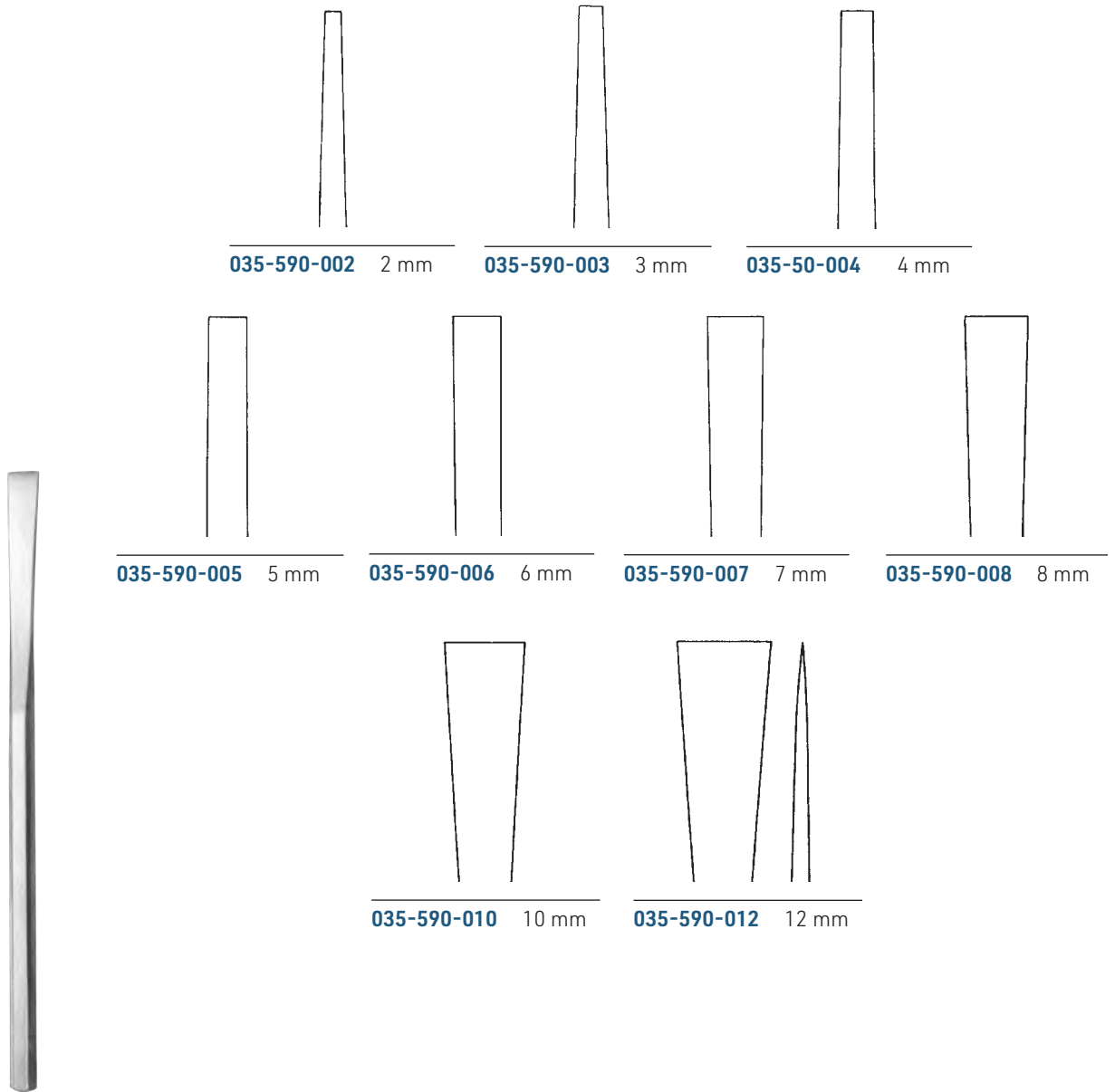

SHEEHAN

035-590-002 - 035-590-012 15,0 cm / 6"



035

Osteotome
Osteotomes
Osteótomos
Osteotomi

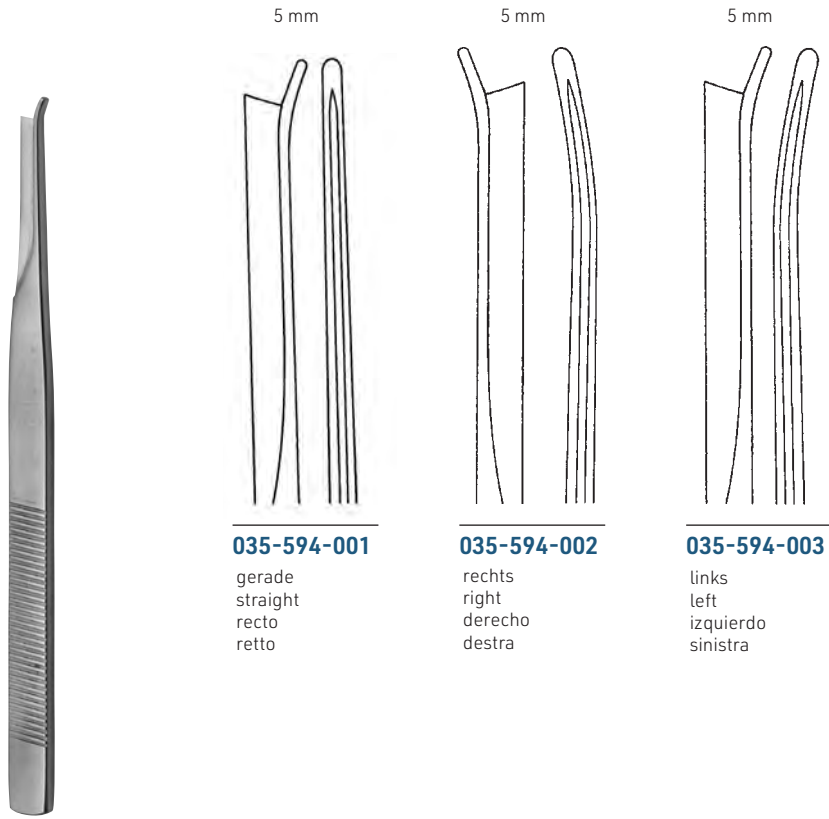

035-594-001

gerade
straight
recto
retto

035-594-002

rechts
right
derecho
destra

035-594-003

links
left
izquierdo
sinistra

SILVER

035-594-001 - 035-594-003 18,0 cm / 7"

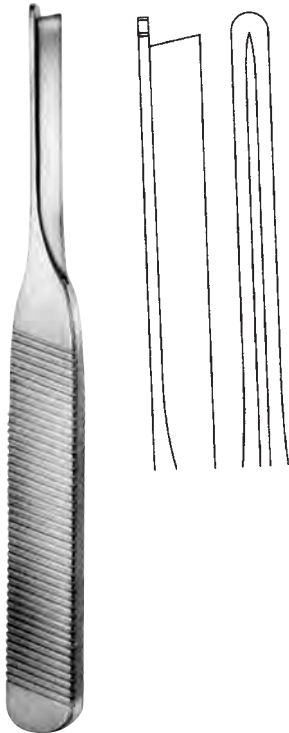

PARKES

035-596-160 16,0 cm / 6 1/4"



links abgewinkelt
 angeled to left
 angulado por izquierdo
 anguato a sinistra

JOSEPH

035-611-001 17,0 cm / 6³/₄"



rechts abgewinkelt
 angeled to right
 angulado por derecho
 anguato a destra

JOSEPH

035-611-002 17,0 cm / 6³/₄"

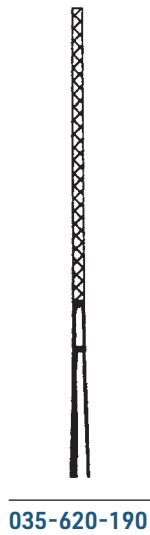

035-620-190

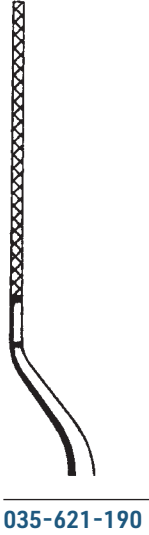

035-621-190



035-623-190

Arbeitslänge 40 mm
 working length 40 mm
 longitud de la punta 40 mm
 lunghezza utile 40 mm

JOSEPH

035-620-190 - 035-623-190 19,0 cm / 7¹/₂"

Knorpelquetsche
 Cartilage Crusher
 Machacadora
 Torchio per cartilagine



COTTLE

035-630-000



035

Nasenraspeln, Knochenfeilen, Antrumraspeln
 Nasal Rasps, Bone Files, Antrum Rasps
 Escofinas nasales, Limas para huesos, Escofinas para el antro
 Raspe nasali, Lime per ossa, Raspe per seno mascellare

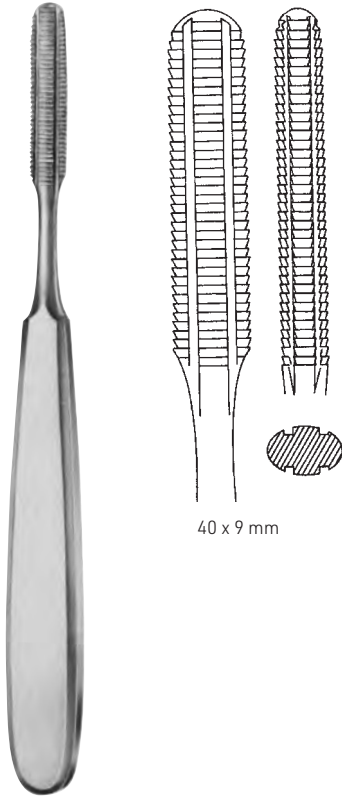

40 x 9 mm

MALTZ

035-650-175 17,5 cm / 7"

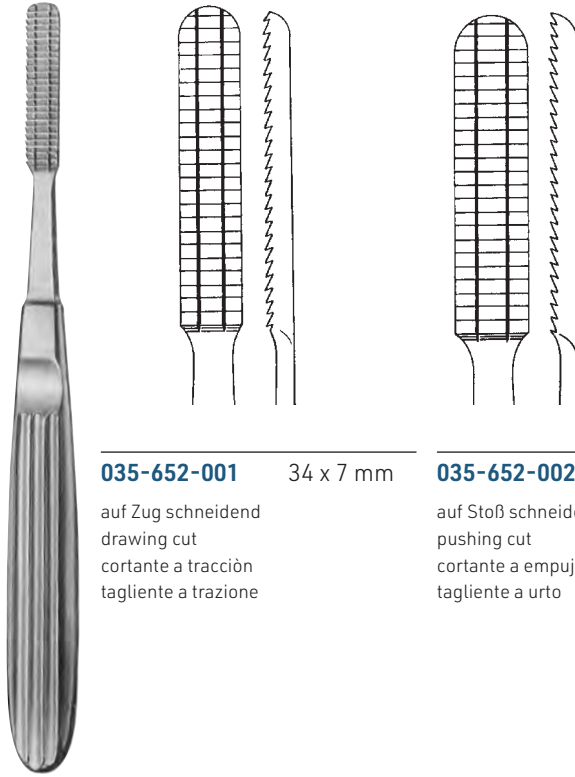

035-652-001 34 x 7 mm

auf Zug schneidend
 drawing cut
 cortante a tracciòn
 tagliente a trazione

035-652-002 34 x 7 mm

auf Stoß schneidend
 pushing cut
 cortante a empuje
 tagliente a urto

MALTZ

035-652-001 - 035-652-002 17,0 cm / 6³/₄"

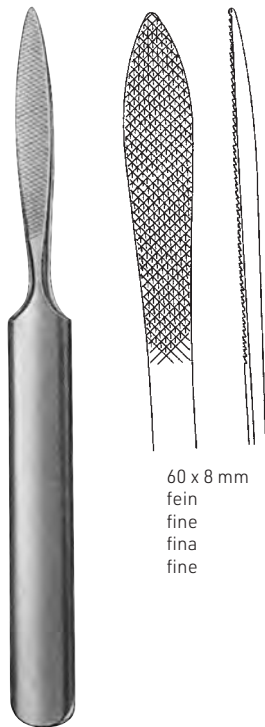

60 x 8 mm
 fein
 fine
 fina
 fine

JOSEPH

035-654-160 16,0 cm / 6¹/₄"

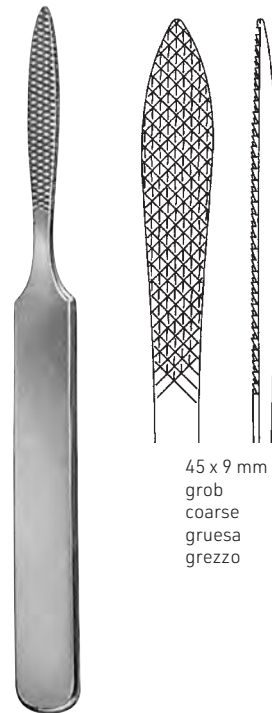

45 x 9 mm
 grob
 coarse
 gruesa
 grezzo

JOSEPH

035-655-160 16,0 cm / 6¹/₄"

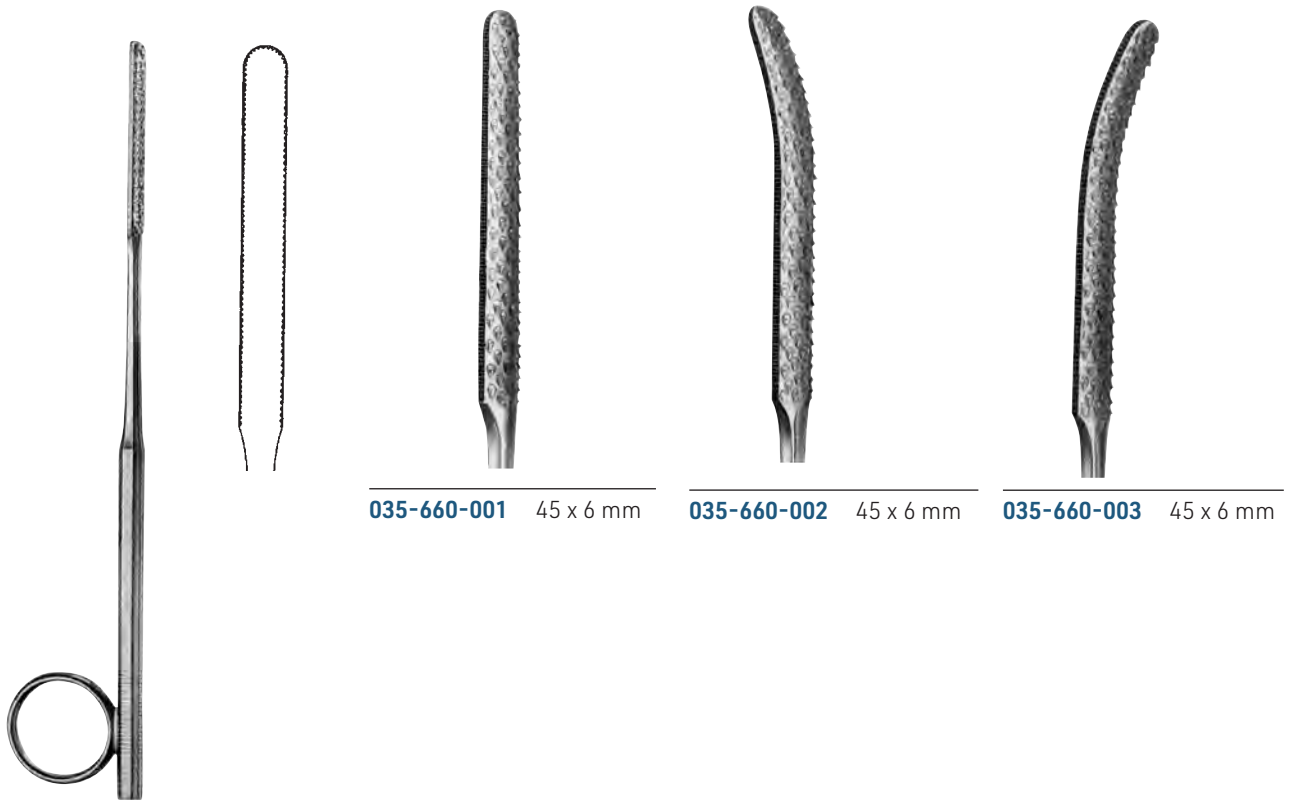

035-660-001 45 x 6 mm

035-660-002 45 x 6 mm

035-660-003 45 x 6 mm

GALLAHER

035-660-001 - 035-660-003 17,0 cm / 6³/₄"

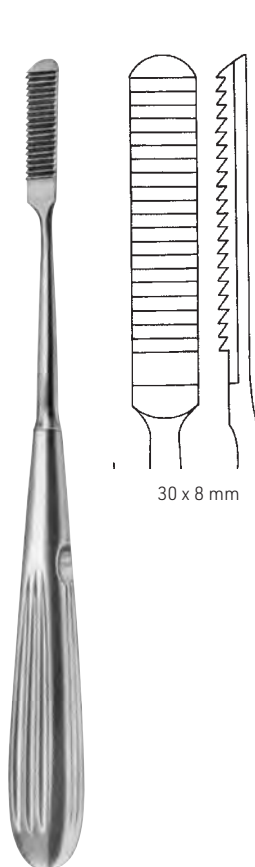

30 x 8 mm

COTTLE

035-664-210 21,0 cm / 8¹/₄"

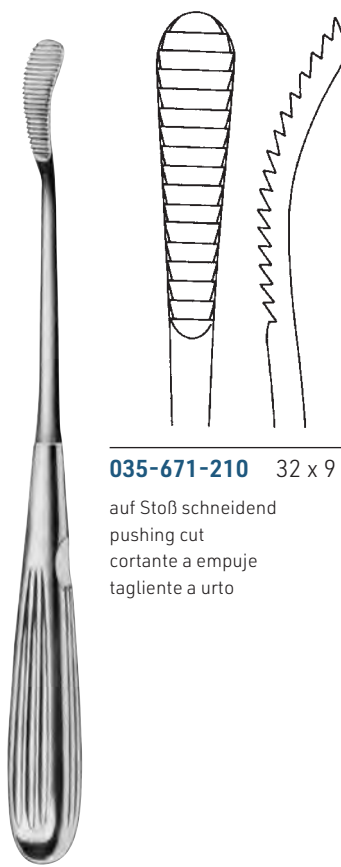

035-671-210 32 x 9 mm

auf Stoß schneidend
 pushing cut
 cortante a empuje
 tagliante a urto

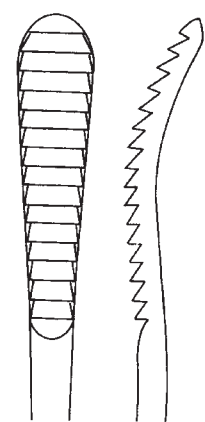

035-673-210 32 x 9 mm

auf Zug schneidend
 drawing cut
 cortante a tracciòn
 tagliante a trazione

AUFRICHT

035-671-210 - 035-673-210 21,0 cm / 8¹/₄"



035

Nasenraspeln
Nasal Rasps
Escofinas nasales
Raspe nasali

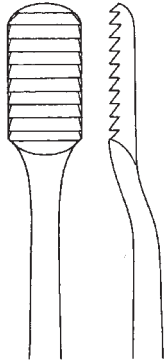

035-674-190

auf Zug schneidend
drawing cut
cortante a traccion
tagliente a trazione

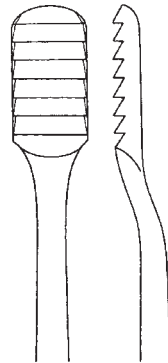

035-676-190

auf Zug schneidend
drawing cut
cortante a traccion
tagliente a trazione

LEWIS

035-674-190 - 035-676-190

19,0 cm / 7 1/2"



fein / grob
fine / coarse
fina / gruesa
fino / grezzo

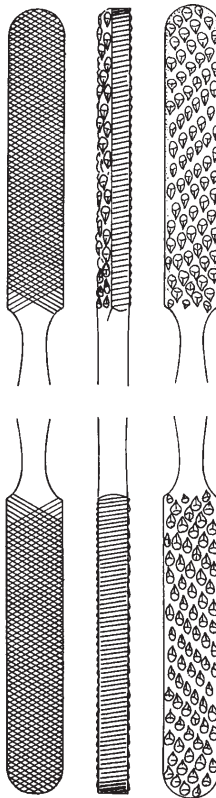

30 x 8 mm

FOMON

035-680-210 21,0 cm / 8 1/4"

TC

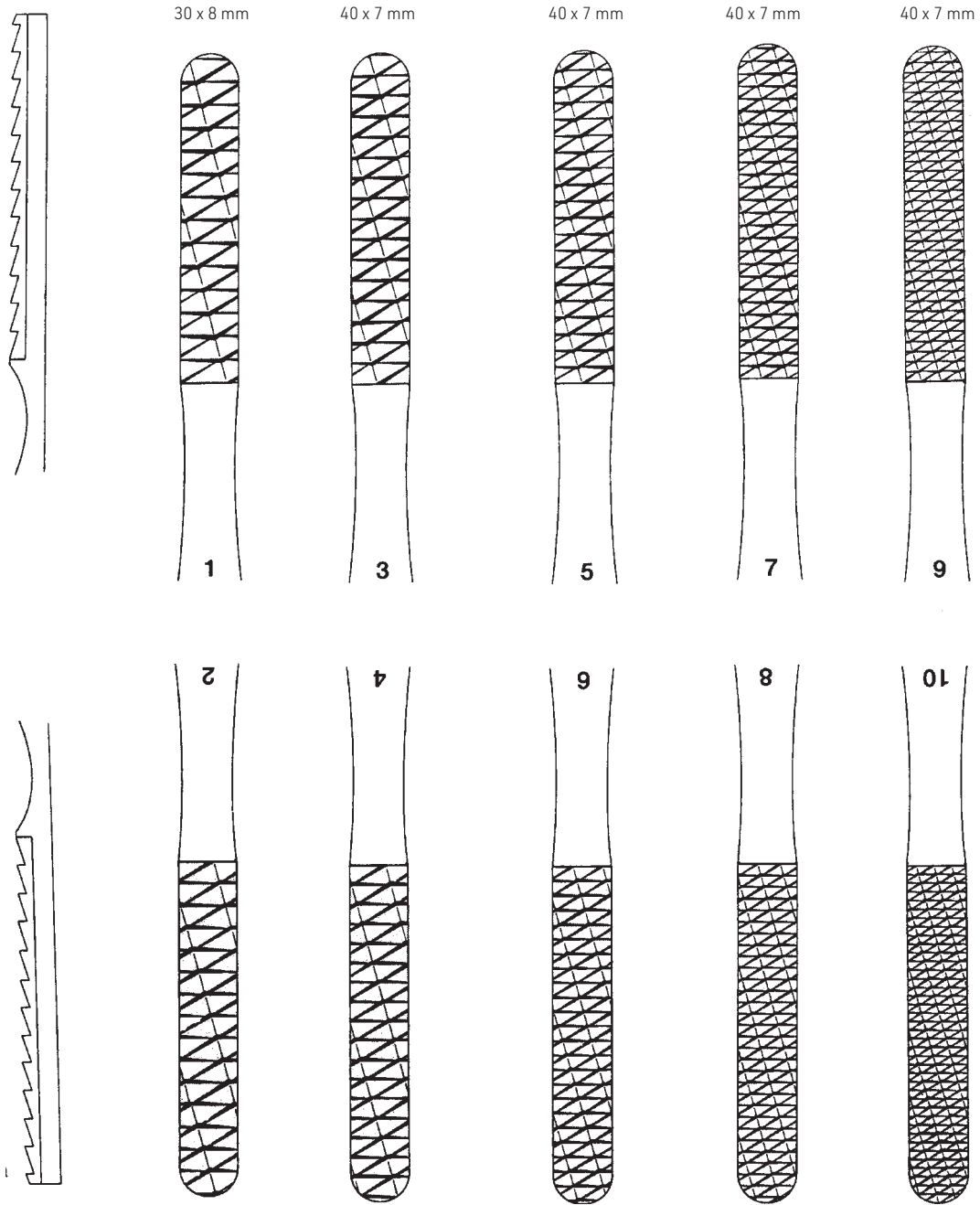

Fig. 1/2
 035-690-012

Fig. 3/4
 035-690-034

Fig. 5/6
 035-690-056

Fig. 7/8
 035-690-078

Fig. 9/10
 035-690-090



FOMON

035-690-012 - 035-690-090

20,5 cm / 8"



035

Nasenhäkchen, Nasenhaken
 Nasal Hooks, Nasal Retractors
 Ganchitos nasales, Separadores nasales
 Uncini nasali, Divaricatori nasali



scharf
 sharp
 agudo
 acuto

COTTLE

035-701-170 17,0 cm / 6³/₄"



035-703-001

scharf
 sharp
 agudo
 acuto



035-703-002

scharf
 sharp
 agudo
 acuto



035-703-003

scharf
 sharp
 agudo
 acuto



COTTLE

035-703-001 - 035-703-003 14,5 cm / 5³/₄"



Knopfende
 button end
 punta abotonada
 fine abbottonato

LANGE

035-705-220 22,0 cm / 8³/₄"

Nasenflügelhäkchen
 Alar Hooklet
 Ganchito para alas de nariz
 Uncino per le inne
 nasali

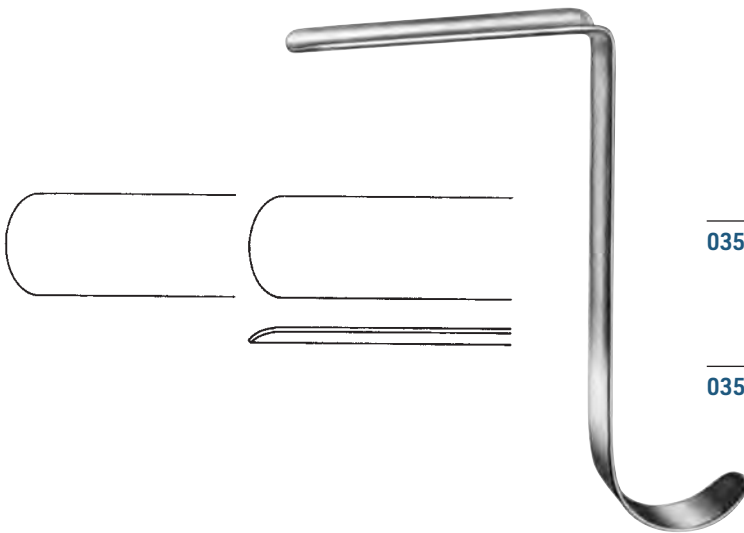

035-709-001 20 x 9 mm

035-709-002 28 x 13 mm

035-709-003 41 x 13 mm

035-709-004 60 x 14 mm

CONVERSE

035-709-001 - 035-709-004 9,0 cm / 3¹/₂"



Knopfende
button end
punta abotonada
fine abbottonato

FOMON

035-711-170 17,0 cm / 7 1/2"

Nasenflügelhäkchen
Alar Hooklet
Ganchito para alas de nariz
Uncino per le inne
nasali

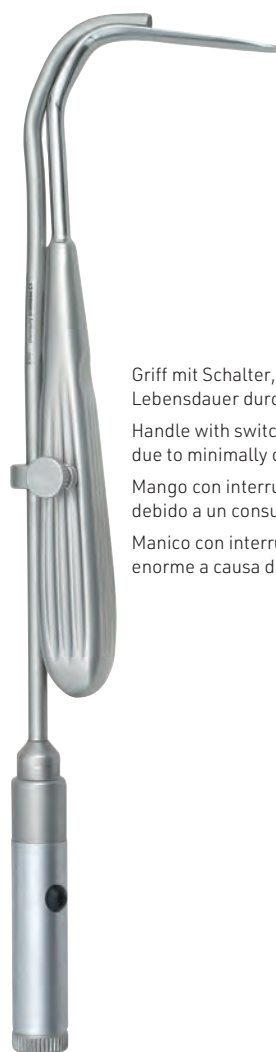

Griff mit Schalter, integrierter Batterie. Extrem lange Lebensdauer durch minimale Stromaufnahme.

Handle with switch, included battery. Substandard lifetime due to minimally current consumption.

Mango con interruptor, batería incluida. Enorme vida útil debido a un consumo mínimo de corriente.

Manico con interruttore, batteria inclusa. La vita utile ed enorme a causa di un minimo consumo di corrente.

035-716-215 21,5 cm / 8 1/2"

Nasenrückenhaken mit Fiberglas-Lichtträger
Nasal retractor with fiber optic light carrier
Separador nasal con portador de luz fibra óptica
Divaricatore nasale con supporto per illuminazione fibra ottica



035

Nasenhäkchen
Nasal Hooks
Ganchitos nasales
Uncini nasali

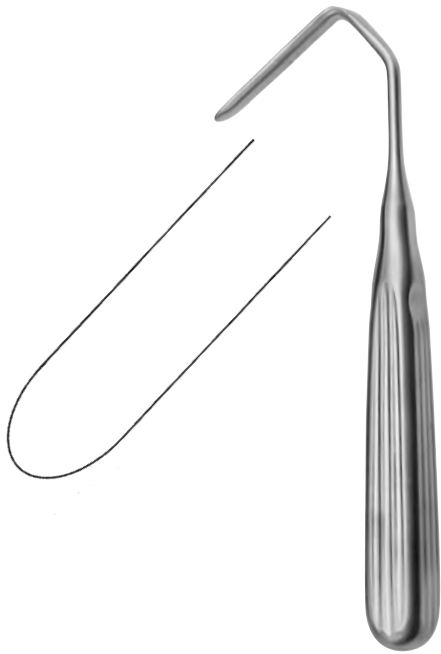

AUFRICHT

035-715-160 16,0 cm / 6 1/4"



KILNER

035-717-080 8,0 cm / 3 1/2"

Nasenflügelhäkchen
Alar Hooklet
Ganchito para alas de nariz
Uncino per le inne
nasali

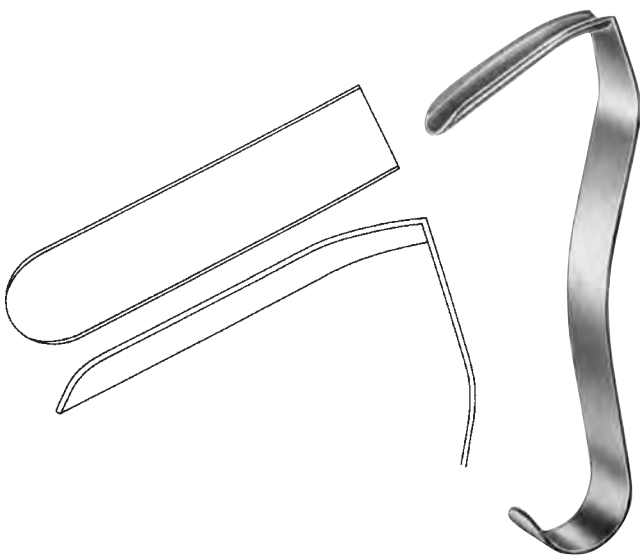

Blatt 45 x 10 mm
blade 45 x 10 mm
hoja 45 x 10 mm
lama 45 x 10 mm

CONVERSE

035-719-105 10,5 cm / 4"

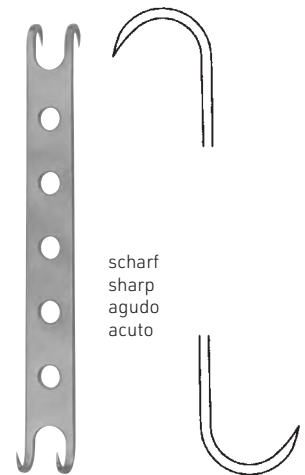

scharf
sharp
agudo
acuto

CONVERSE

035-721-115 12cm / 4 3/4"

Nasenflügelhäkchen
Alar Hooklet
Ganchito para alas de nariz
Uncino per le inne
nasali



scharf
 sharp
 agudo
 acuto

FREER
035-723-150 15,0 cm / 6"



JOSEPH
035-725-001 15,0 cm / 6"

Schleimhauthäkchen
 Mucosa Hooklet
 Ganchito para mucosa
 Uncino per mucosa



JOSEPH
035-725-002 - 035-725-010 16,0 cm / 6 1/4"

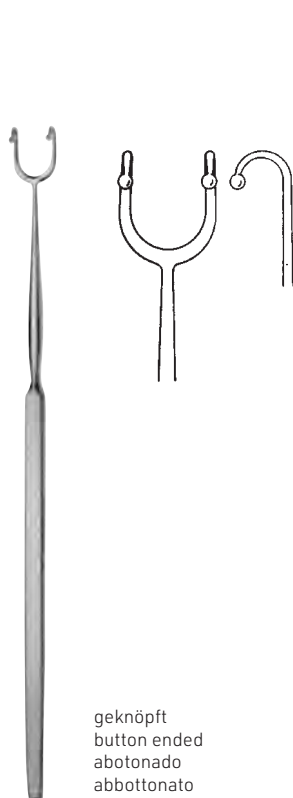
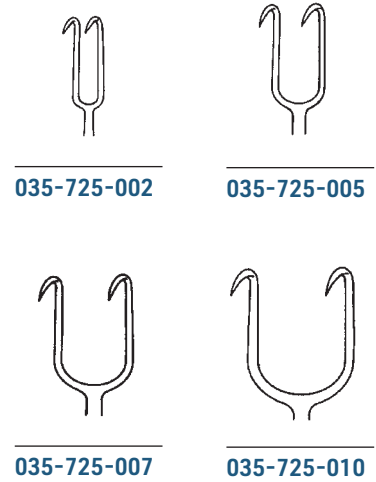

geknöpft
 button ended
 abotonado
 abbottonato

FOMON
035-729-160 16,0 cm / 6 1/4"



geknöpft
 button ended
 abotonada
 abbottonato

COTTLE-NEIVERT
035-731-200 20,0 cm / 8"

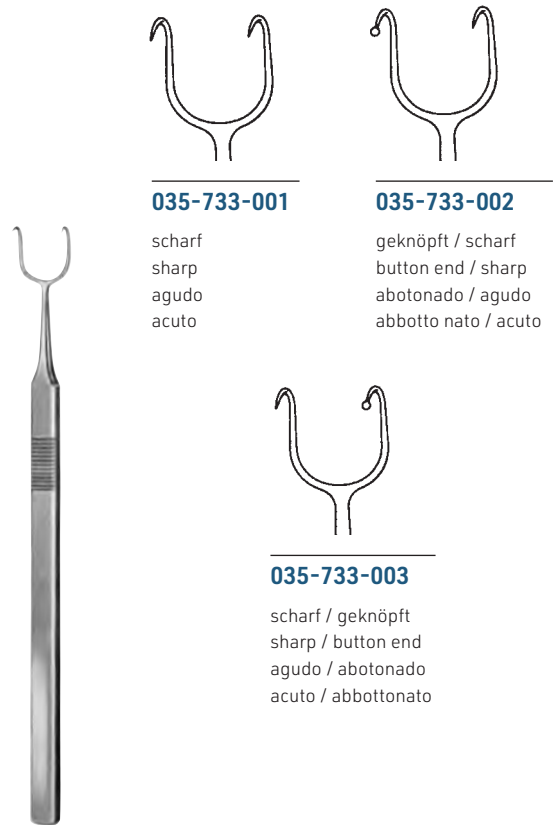

035-733-001 **035-733-002**

scharf
 sharp
 agudo
 acuto

geknöpft / scharf
 button end / sharp
 abotonado / agudo
 abbottonato / acuto

035-733-003
 scharf / geknöpft
 sharp / button end
 agudo / abotonado
 acuto / abbottonato

COTTLE
035-733-001 - 035-733-003 14,5 cm / 5 3/4"



035

Nasenflügelhäkchen
Alar Hooklets
Ganchitos para alas de nariz
Uncini per le pinne nasali

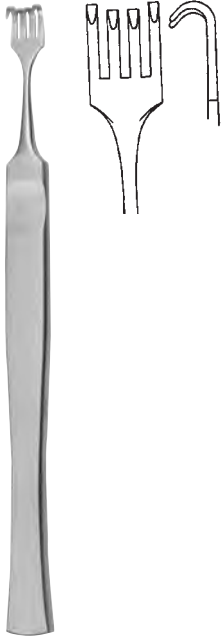

COTTLE

035-735-140 14,0 cm / 5 1/2"



NEIVERT

035-737-170 17,0 cm / 6 3/4"



COTTLE

035-741-140 14,0 cm / 5 1/2"

Sattelhäkchen
Saddle Hook
Separador en forma de silla
Elevatori in forma di sella



COTTLE

035-743-160 16,0 cm / 6 1/4"



Blatt
blade
hoja
lama
60 x 6,5 mm

stumpf
blunt
romo
smusso

AUFRICT

035-745-120 12,0 cm / 4 3/4"

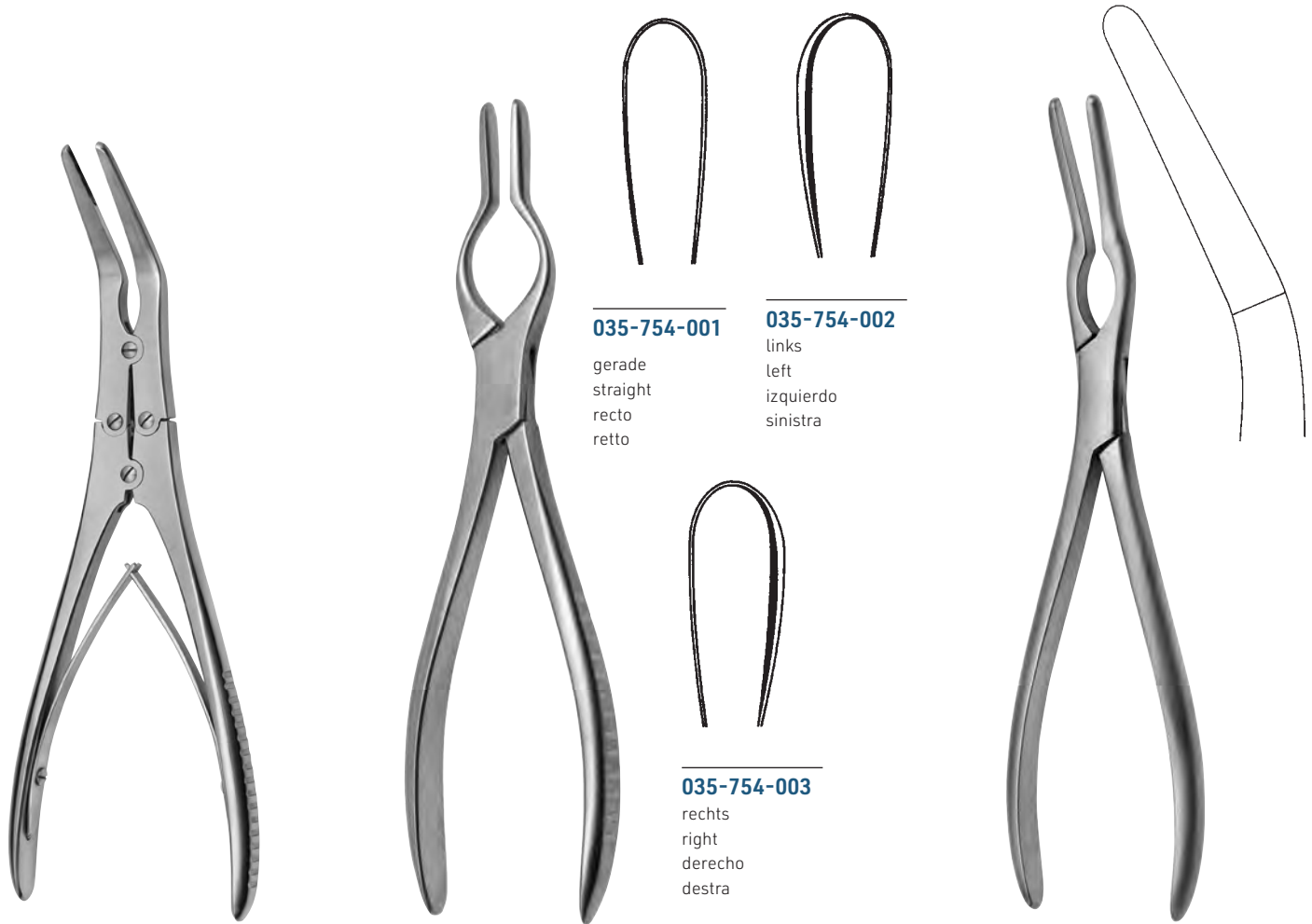

KRESSNER
035-751-210 21,0 cm / 8¹/₄"

COTTLE-WALSHAM
035-754-001 - 035-754-003 23,0 cm / 9"

ASCH
035-757-225 22,5 cm / 8³/₄"



1,7 mm breit mit Zähnen
 1,7 mm wide with teeth
 1,7 mm de ancho con dientes
 largo 1,7 mm con denti

COTTLE
035-765-140 14,0 cm / 5¹/₂"

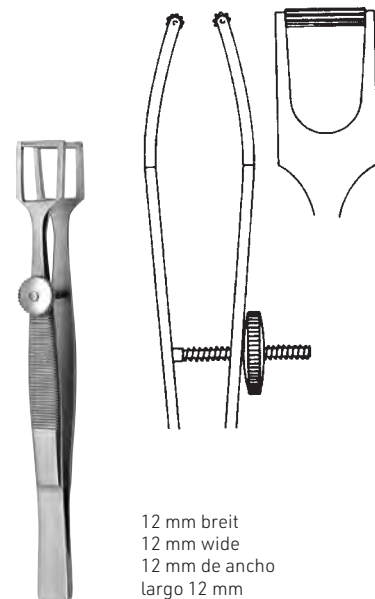

12 mm breit
 12 mm wide
 12 mm de ancho
 largo 12 mm

COTTLE
035-766-110 11,0 cm / 4¹/₄"



035

Ringmesser
Adenoid Currettes
Cuchillos para adenoides
Coltelli per vegetazioni adenoidee



FAULKNER

035-781-210 21,0 cm / 8¹/₄"



COAKLEY

035-785-001 - 035-785-006 17,0 cm / 6³/₄"



035-785-001



035-785-002



035-785-003



035-785-004



035-785-005



035-785-006



BECKMANN

035-800-001 - 035-800-006 22,0 cm / 8³/₄"

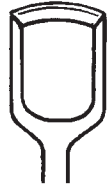

FIG. 1

035-800-001 10 mm



FIG. 2

035-800-002 12 mm

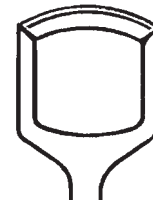

FIG. 3

035-800-003 14 mm

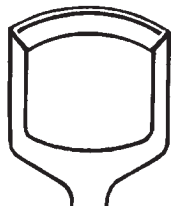

FIG. 4

035-800-004 16 mm

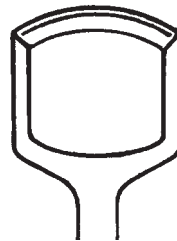

FIG. 5

035-800-005 20 mm

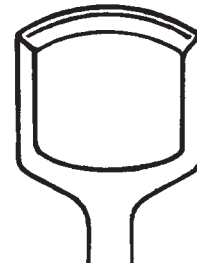

FIG. 6

035-800-006 22 mm



trapezförmig gefenstert
 trapezoidal fenestrated
 fenestrado trapecialmente
 fenestrato a forma di trapezio

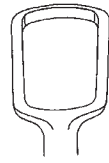

FIG. 1
035-810-001 10 mm

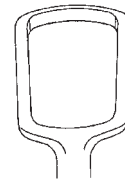

FIG. 2
035-810-002 14 mm

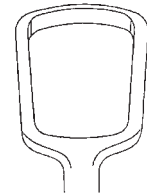

FIG. 3
035-810-003 16 mm

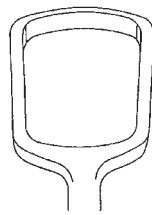

FIG. 4
035-810-004 18 mm

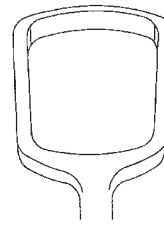

FIG. 5
035-810-005 20 mm

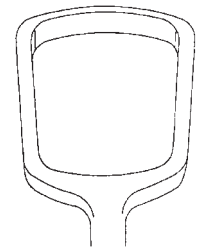

FIG. 6
035-810-006 22 mm

BECKMANN

035-810-001 - 035-810-006 22,0 cm / 8³/₄"



FIG. 1
035-820-001 16 mm



FIG. 2
035-820-002 18 mm



FIG. 3
035-820-003 20 mm



FIG. 4
035-820-004 23 mm

BARNHILL

035-820-001 - 035-820-004 21,0 cm / 8¹/₄"



035

Ringmesser
Adenoid Currettes
Cuchillos para adenoides
Coltelli per vegetazioni adenoidee

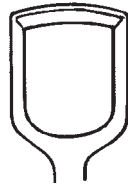

FIG. 1
035-830-001

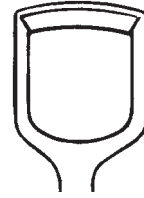

FIG. 2
035-830-002

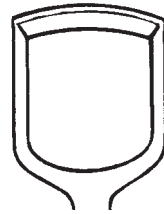

FIG. 3
035-830-003

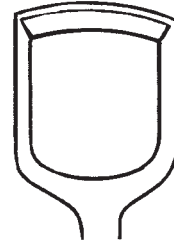

FIG. 4
035-830-004

ST. CLAIR-THOMSON

035-830-001 - 035-830-004 21,0 cm / 8 1/4"



FIG. 1
035-840-001



FIG. 2
035-840-002

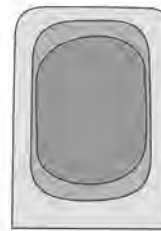

FIG. 3
035-840-003

mit gelochter Klinge
with perforated blade
con hoja perforada
con lama forato

Ersatzklingen
Spare Blades
Hojas de repuesto
Lame di ricambio

FIG. 1
035-841-001

FIG. 2
035-841-002

FIG. 3
035-841-003

LA FORCE

035-840-001 - 035-840-003 25,0 cm / 10"

Ø 3 mm



Spülkanüle
 Irrigation Cannula
 Sonda irrigadora
 Cannula per lavaggio

EICKEN-KILLIAN

035-851-140 14,0 cm / 5 1/2"



GUILLEN

035-857-190 19,0 cm / 7 1/2"

Saugraspatorium
 Suction Raspatory
 Legra de succión
 Raspatorio con aspiratore



SIEBENMANN

035-855-015	15,0 cm / 6"	Ø 1,5 mm
035-855-017	15,0 cm / 6"	Ø 1,7 mm
035-855-020	15,0 cm / 6"	Ø 2,0 mm
035-855-025	15,0 cm / 6"	Ø 2,5 mm
035-855-030	15,0 cm / 6"	Ø 3,0 mm



RITTER-HALLE

035-859-025	14,5 cm / 5 3/4"	Ø 2,5 mm
035-859-030	14,5 cm / 5 3/4"	Ø 3,0 mm
035-855-040	14,5 cm / 5 3/4"	Ø 4,0 mm
035-859-050	14,5 cm / 5 3/4"	Ø 5,0 mm



035



037

Mund-, Kiefer- und
Gesichtschirurgie
Oral Maxillo-Facial
Surgery
Cirugía oral y maxilofacial
Chirurgia maxillo-facciale



037

Serviettenhalter, Fingerschützer, Mundkeile
Napkin Holder Finger, Protector Mouth Gags
Porta servilletas, Dedales, Abrebocas
Porta-salviette, Protettore per dita, Apribocca



ADAMS
037-101-001



LANGENBECK
037-105-001



LANGENBECK
037-105-002



LANGENBECK
037-105-003

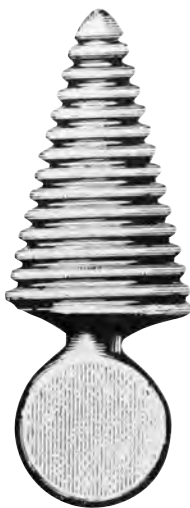

MAUNDER
037-108-100 10,0 cm / 4"



PITHA
037-111-001



HEISTER

037-120-130 13,0 cm / 5"



MOLT / DOYEN-JANSEN

037-123-110 11,0 cm / 4 1/2"

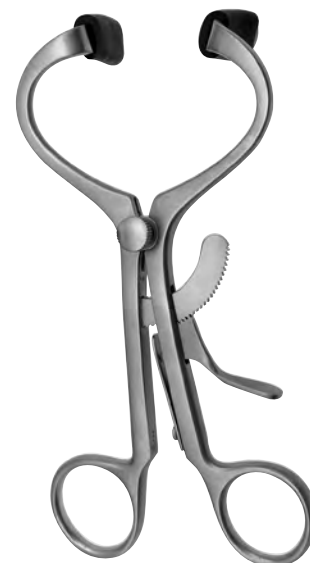

MOLT / DOYEN-JANSEN

037-123-140 14,0 cm / 5 1/2"



DENHART

037-126-002

Silikonbacken, allein (Paar)
 Silicon jaws, only (pair)
 Bocas de silicona, sueltas (par)
 Bocca da silicona, sola (paio)

DENHART

037-125-120 12,0 cm / 4 3/4"



ROER-KÖNIG

037-127-160 16,0 cm / 6 1/4"
037-127-200 20,0 cm / 8"



037

Mundsperrer
Mouth Gags
Abrebocas
Apribocca



037-142-010

Mundsperrer-Rahmen
Frame for Mouth Gag
Bastidor para abreboaca
Telaio per apribocca

KILNER-DOUGHTY

037-142-000

komplett, bestehend aus Rahmen und 3 Zungenspatel Fig. 1 bis 3, 2 Zahnplatten und 1 Gaumenplatte
complete, consisting of frame and 3 tongue depressors no. 1 to 3, 2 tooth plates and 1 palate plate
completo, consiste de bastidor y 3 babajalenguas no. 1 hasta 3, 2 placas para dientes y 1 placa paladar
completo, composto di telaio e 3 abassalingua no. 1 fino a 3, 2 placche per denti e 1 placa per palato



FIG. 1 29 x 70 mm
037-142-001 13,5 cm / 5 1/4"



FIG. 2 34 x 80 mm
037-142-002 13,5 cm / 5 1/4"



FIG. 3 38 X 85 mm
037-142-003 13,5 cm / 5 1/4"

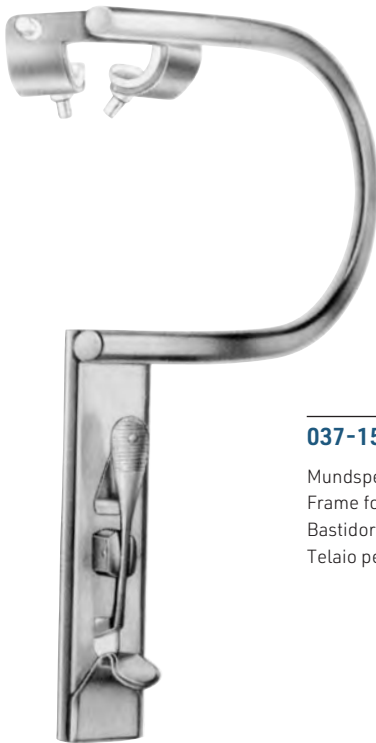

037-150-010

Mundsperrer-Rahmen
 Frame for Mouth Gag
 Bastidor para abrebooca
 Telaio per apribocca



DAVIS-BOYLE

037-150-001 13,5 cm / 5 1/4" 25 x 108 mm

Zungenspatel mit fester Absaugung
 Tongue Depressor with fixed suction tube
 Bajalengua con tubo de succión fijo
 Abassalingua con tubo di aspirazione fisso

DAVIS-BOYLE

037-150-000

komplett, bestehend aus Rahmen und fünf Zungenspatel Fig. 1 bis 5
 complete, consisting of frame and five tongue depressors no. 1 to 5
 completo, consiste de bastidor y cinco babajalenguas no. 1 hasta 5
 completo, composto di telaio e cinque abassalingua no. 1 fino a 5



DAVIS-BOYLE

037-150-002 13,5 cm / 5 1/4" 25 x 95 mm

Zungenspatel mit fester Absaugung
 Tongue Depressor with fixed suction tube
 Bajalengua con tubo de succión fijo
 Abassalingua con tubo di aspirazione fisso



DAVIS-BOYLE

037-150-003 13,5 cm / 5 1/4" 24 x 80 mm

Zungenspatel mit fester Absaugung
 Tongue Depressor with fixed suction tube
 Bajalengua con tubo de succión fijo
 Abassalingua con tubo di aspirazione fisso



DAVIS-BOYLE

037-150-004 13,5 cm / 5 1/4" 23 x 65 mm

Zungenspatel mit fester Absaugung
 Tongue Depressor with fixed suction tube
 Bajalengua con tubo de succión fijo
 Abassalingua con tubo di aspirazione fisso



DAVIS-BOYLE

037-150-005 13,5 cm / 5 1/4" 20 x 30 mm

Zungenspatel ohne Absaugung
 Tongue Depressor without suction tube
 Bajalengua sin tubo de succión fijo
 Abassalingua senza tubo di aspirazione fisso



037

Mundsperrer
Mouth Gags
Abrebocas
Apribocca



MC IVOR

037-160-000

komplett mit drei Zungenspatel
complete with three tongue depressors
completo con tres babajalenguas
completo e tre abassalingua

MC IVOR

037-160-010

Mundsperrer-Rahmen
Frame for Mouth Gag
Bastidor para abreboca
Telaio per apribocca



MC IVOR

037-160-001 13,5 cm / 5 1/2" 26 x 100 mm

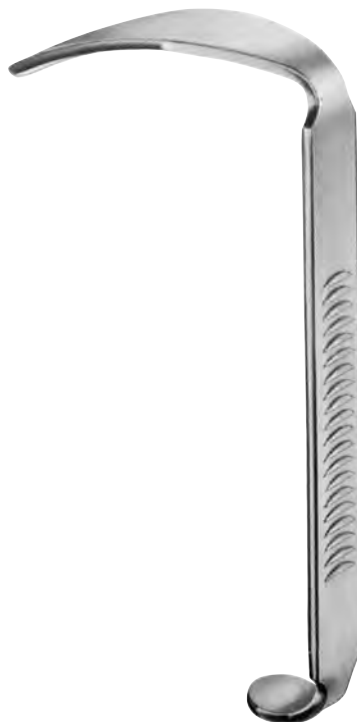

MC IVOR

037-160-002 13,5 cm / 5 1/2" 25 x 85 mm

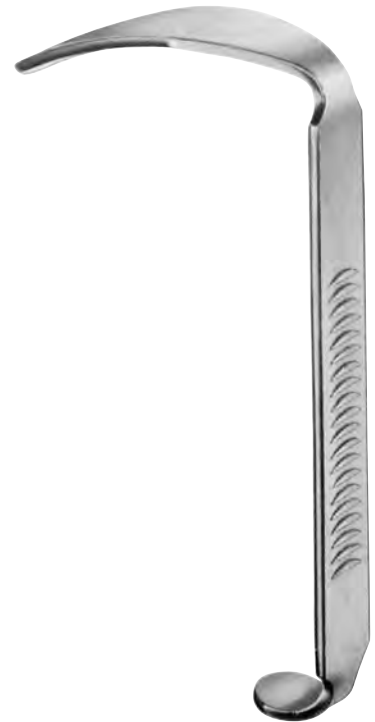

MC IVOR

037-160-003 13,5 cm / 5 1/2" 23 x 75 mm



DINGMANN

037-170-010

Mundsperrer-Rahmen
Frame for Mouth Gag
Bastidor para abrebooca
Telaio per apribocca

DINGMANN

037-170-000

komplett mit Rahmen, 3 Zungenspateln und 2 beweglichen Seitenvalven
Complete with frame, 3 tongue depressors and 2 adjustable lateral blades
Completo con bastidor, 3 bajalenguas y 2 valvas laterales ajustables
completo con telaio, 3 abassalingua e 2 valve laterali movibili

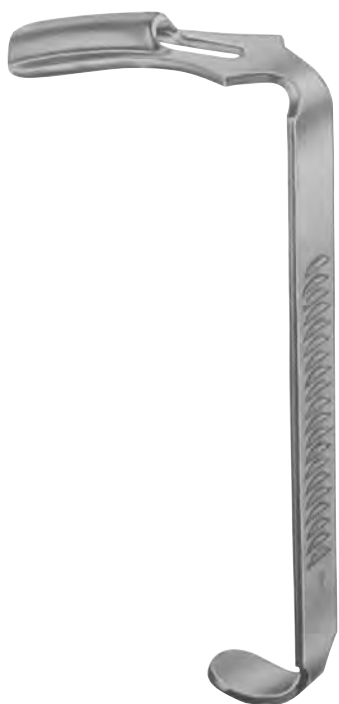

DINGMANN

037-170-001 13,5 cm / 5 1/2" 25 x 65 mm

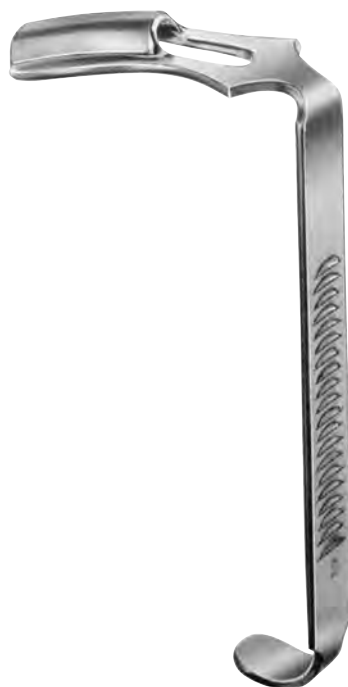

DINGMANN

037-170-002 13,5 cm / 5 1/2" 29 x 70 mm



DINGMANN

037-170-003 13,5 cm / 5 1/2" 32 x 80 mm



037

Mundsperrer
Mouth Gags
Abrebocas
Apribocca



WHITEHEAD

037-173-110	11,0 cm / 4 ¹ / ₄ "
037-173-130	13,0 cm / 5"
037-173-150	15,0 cm / 6"

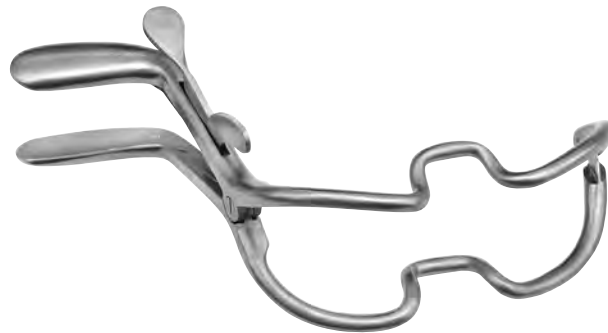

JENNINGS

037-175-090	9,0 cm / 3 ¹ / ₂ "
037-175-110	11,0 cm / 4 ¹ / ₄ "
037-175-130	13,0 cm / 5"
037-175-150	15,0 cm / 6"



SIMPLEX

037-183-110 11,0 cm / 4 1/2"



STERNBERG

037-185-120 12,0 cm / 4 3/4"
037-185-140 14,0 cm / 5 1/2"
037-185-160 16,0 cm / 6 1/4"



037-187-190 19,0 cm / 7 1/2"

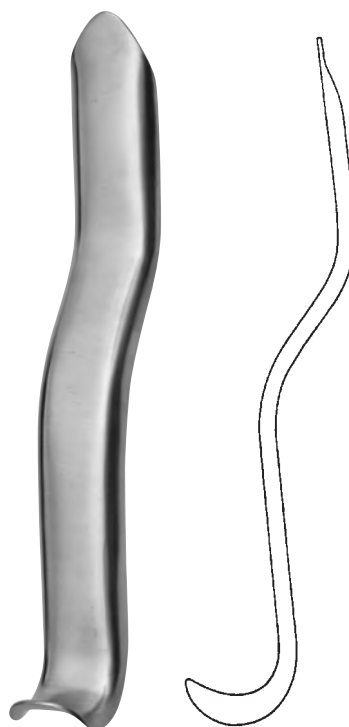

CAWOOD-MINNESOTA

037-191-155 15,5 cm / 6"



037

Wangen- und Lippenhalter, Zungendrücker
Cheek and Lip Retractors, Tongue Depressors
Separadores para mejillas y labios, Abjalenguas
Divaricatori per guanci e labbra, Abbassalingua

83x25 mm

80x25 mm



HARTMANN
037-193-150 15,0 cm / 6"



TOBOLD
037-195-145 14,5 cm / 5 1/2"



TOBOLD
037-197-145 14,5 cm / 5 1/2"

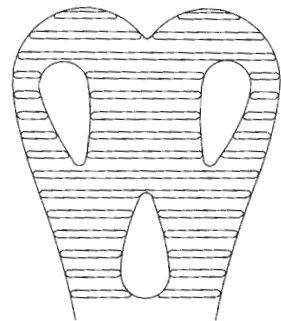

037-201-001 14,0 cm / 5 1/2"



ANDREW
037-199-110 11,0 cm / 4 3/8"



WIEDER
037-201-001 - 037-201-002

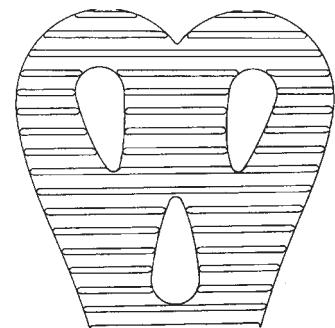

037-201-002 15,0 cm / 6"



BUCHWALD

037-215-170 17,0 cm / 6³/₄"

037-215-190 19,0 cm / 7¹/₂"



BRUENINGS

037-217-190 19,0 cm / 7¹/₂"



037-219-145 14,5 cm / 5³/₄"



037

Zungenzangen
Tongue Holding Forceps
Pinzas tira-lengua
Pinze per lingua



COLLIN

037-220-160 16,0 cm / 6¹/₄"
037-220-180 18,0 cm / 7"



YOUNG

037-223-160 16,0 cm / 6¹/₄"

037-224-002

Gummibacken, allein (Paar)
Rubber inserts, only (pair)
Bocas de goma, sueltas (par)
Cuscino di gomma, soli (paio)



OBWEGESER

037-251-040 - 037-251-080 22,0 cm / 8³/₄"



037-251-040 11 x 40 mm



037-251-055 11 x 55 mm



037-251-080 16 x 80 mm



037

Ramushaken
Ramus Retractors
Separadores para el ramo
Separatore per ramo



OBWEGESER

037-253-220 22,0 cm / 8³/₄" 10 x 45 mm

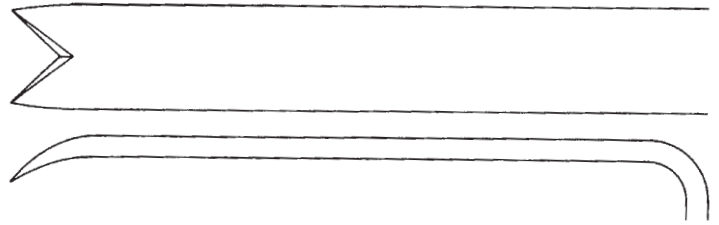

OBWEGESER

037-255-220 22,0 cm / 8³/₄" 11 x 70 mm



OBWEGESER

037-257-160 16,0 cm / 6¹/₂"



OBWEGESER

037-259-008 17,0 cm / 6³/₄" 8 mm
037-259-010 17,0 cm / 6³/₄" 10 mm



037

Raspatorien
Periosteal Elevators
Legras
Elevatori periosteo



037-265-006 6 mm



037-265-007 7 mm



037-265-009 9 mm



037-265-011 11 mm

OBWEGESER

037-265-006 - 037-265-011 17,5 cm / 7¹/₄"



037-267-005 5 mm



037-267-007 7 mm

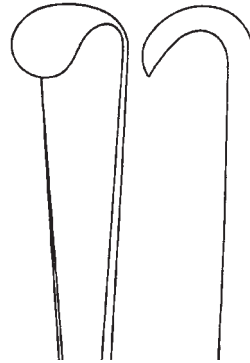

037-267-009 9 mm

OBWEGESER

037-267-005 - 037-267-009 20,0 cm / 8"

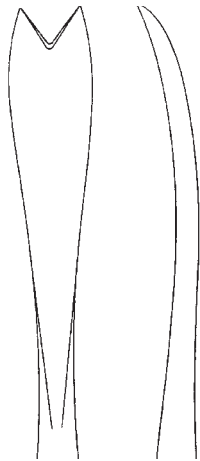

Fig. 1
037-269-001



Fig. 2
037-269-002

OBWEGESER
037-269-001 - 037-269-002 17,5 cm / 7"



stumpf/stumpf
 blunt/blunt
 romo/romo
 smusso/smusso



scharf/stumpf
 sharp/blunt
 agudo/romo
 acuto/smusso



OBWEGESER Fig. 1
037-271-210 21,0 cm / 8 1/2"



OBWEGESER Fig. 2
037-273-210 21,0 cm / 8 1/2"



037-276-025 2,5 mm



037-276-040 4,0 mm

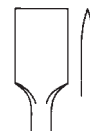

037-276-065 6,5 mm

OBWEGESER
037-276-025 - 037-276-065 15,0 cm / 6"



037

Raspatorien, Osteotome, Ahlen
Raspatories, Osteotomes, Awls
Legras, Osteótomos, Leznas
Periostotomi, Osteotomi, Lesine

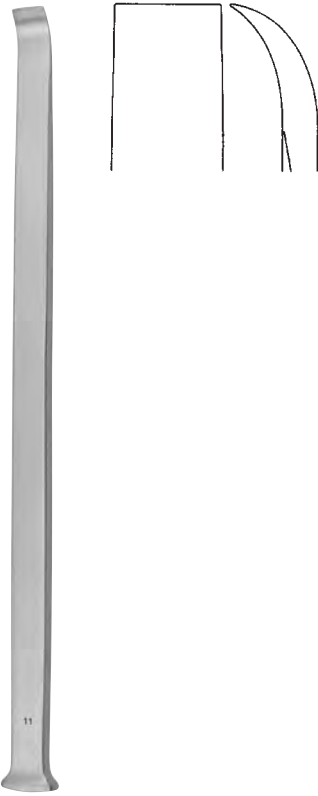

OBWEGESER

037-279-235 23,5 cm / 9 1/4"



037-281-185

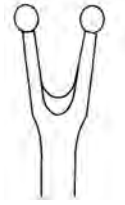

037-283-185



OBWEGESER

037-281-185 - 037-283-185 18,5 cm / 7 1/4"



OBWEGESER

037-291-180 18,0 cm / 7"



OBWEGESER

037-293-140 14,0 cm / 5 1/2"



OBWEGESER

037-295-230 23,0 cm / 9"

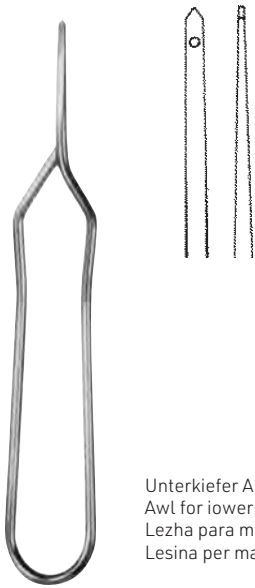

Unterkiefer Ahle
Awl for lower jaw
Lezha para maxilar inferior
Lesina per mascella inferiore

KELSEY-FRY

037-297-150 15,0 cm / 6"

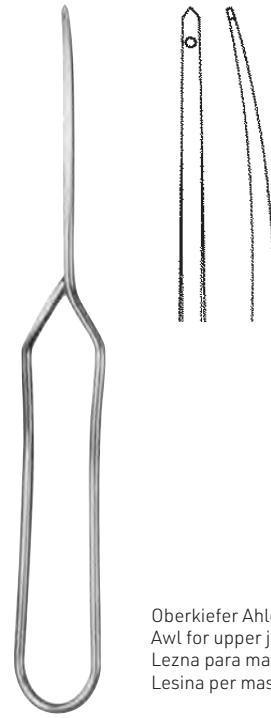

Oberkiefer Ahle
Awl for upper jaw
Lezna para maxilar superior
Lesina per mascella superiore

KELSEY-FRY

037-299-180 18,0 cm / 7 1/4"



037

Repositionszangen
Reposition Forceps
Pinzas para reposición
Pinze per riposizione

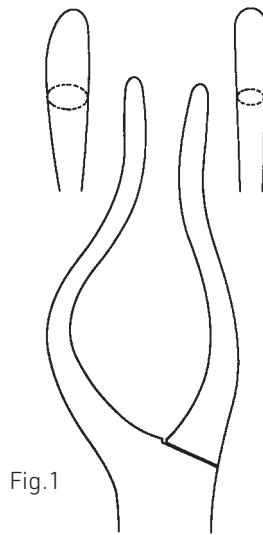

Fig.1

für Babys
for babies
para bebés
per neonati



links
left
izquierda
sinistra

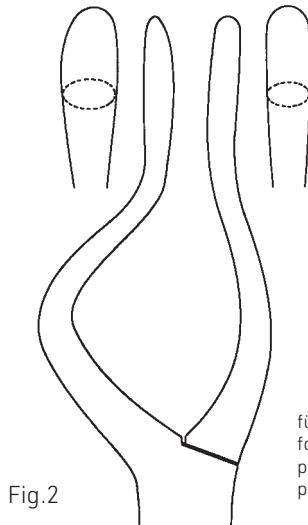

Fig.2

für Kinder
for children
para niños
per bambini

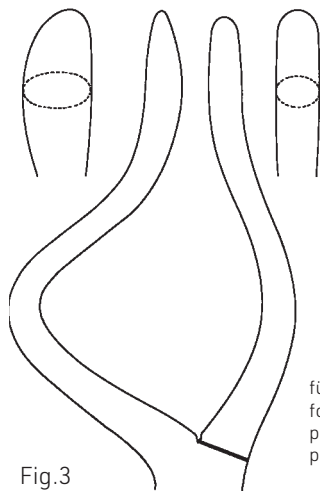

Fig.3

für Erwachsene
for adults
para adultos
per adulti



rechts
right
derecha
destra

ROWE

037-301-001	Fig. 1	22,5 cm
037-301-002	Fig. 2	23,5 cm
037-301-003	Fig. 3	24,0 cm

ROWE

037-303-001	Fig. 1	22,5 cm
037-303-002	Fig. 2	23,5 cm
037-303-003	Fig. 1	24,0 cm



für rechte Hand
 for right hand
 para mano derecha
 per mano destra



für linke Hand
 for left hand
 para mano izquierda
 per mano sinistra



für rechte Hand
 for right hand
 para mano derecha
 per mano destra



für linke Hand
 for left hand
 para mano izquierda
 per mano sinistra

HURD

037-321-210 21,0 cm / 8¹/₄"

HURD

037-323-210 21,0 cm / 8¹/₄"

DUPUY WEISS

037-325-220 22,0 cm / 8³/₄"

DUPUY WEISS

037-327-220 22,0 cm / 8³/₄"



037

Tonsillenmesser
Tonsil Knives
Cuchillos para amígdalas
Bisturi per tonsille



FISCHER
037-345-225 22,5 cm / 9"



ABRAHAM
037-347-210 21,0 cm / 8¹/₄"



BRUENINGS
037-349-230 23,0 cm / 9"



CARPENTER

037-355-250 25,0 cm / 10"

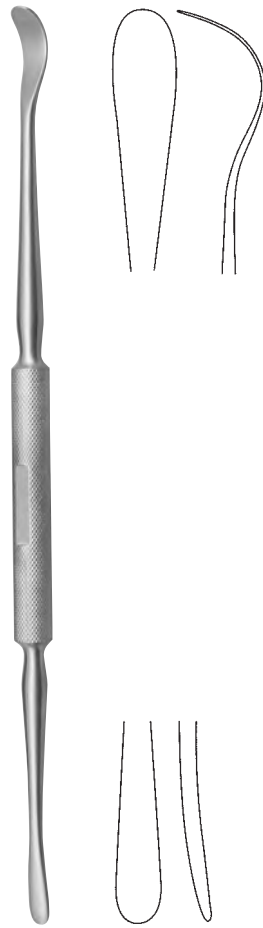

CARPENTER

037-357-240 24,0 cm / 9 1/2"



HURD

037-359-225 22,5 cm / 9"



037

Tonsillendissektoren
Tonsil Dissectors
Disector para amígdalas
Disettori per tonsille

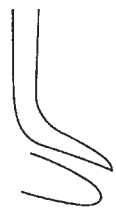
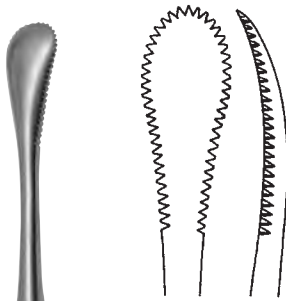

HENKE
037-361-230 23,0 cm / 9"

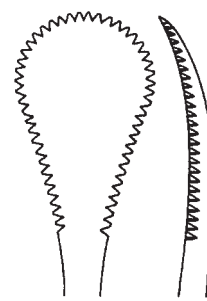

HENKE
037-363-230 23,0 cm / 9"

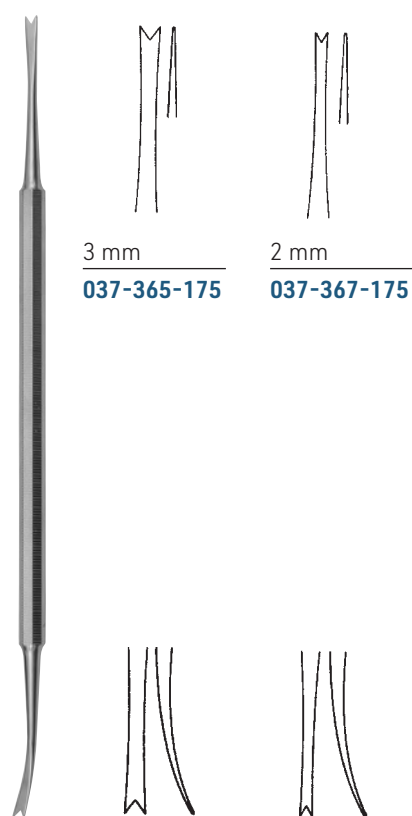

3 mm
037-365-175

2 mm
037-367-175

LUNIATSCHEK
037-365-175 - 037-367-175 17,5 cm / 6³/₄"

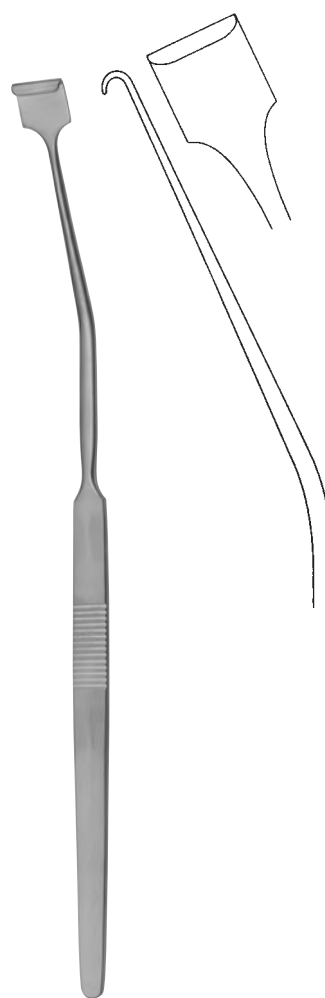

NAGER
037-369-240 24,0 cm / 9"



037

Tonsillenzangen
Tonsil Forceps
Pinzas para amígdalas
Pinze per tonsille

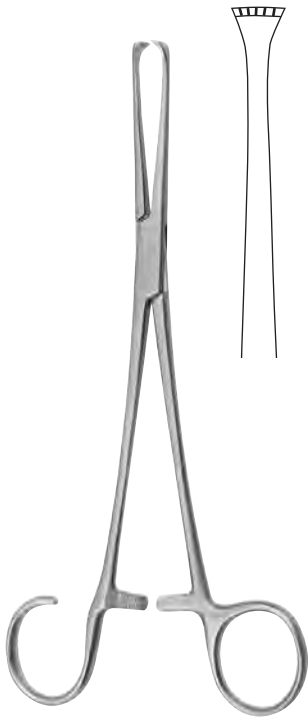

WHITE (COLVER)

037-378-190 19,0 cm / 7½"

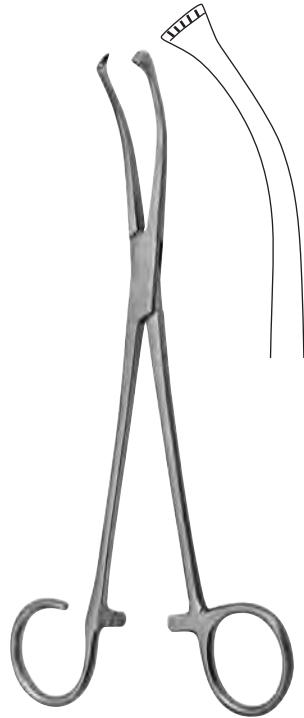

WHITE (COLVER)

037-379-180 18,0 cm / 7"



WHITE

037-381-180 18,0 cm / 7"
037-381-230 23,0 cm / 9"

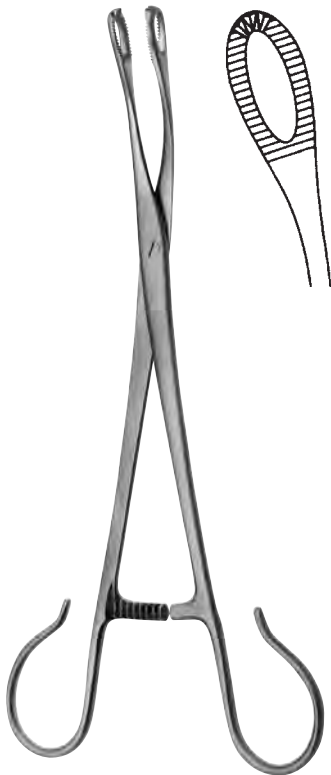

BLOHMKE

037-383-200 20,0 cm / 8"

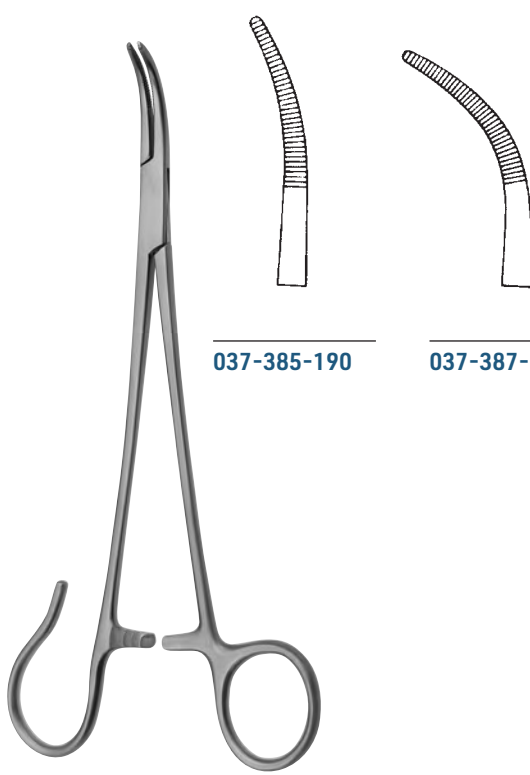

037-385-190

037-387-190

SCHNIDT

037-385-190 - 037-387-190 19,0 cm / 7½"

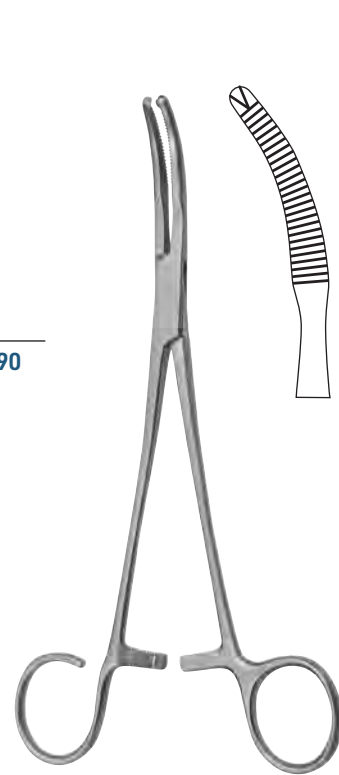

MIKULICZ

037-389-185 18,5 cm / 7¼"



Packung à 100 Stk.
 package with 100 pcs.
 paquete de 100 piezas
 confezione di 100 pezzi



Bündel mit 12 Stk.
 bundle with 12 pcs.
 manojo de 12 piezas
 manello di 12 pezzi

037-400-040 40 mm
037-400-050 50 mm

037-401-035 Ø 0,35 mm
037-401-040 Ø 0,40 mm
037-401-045 Ø 0,45 mm
037-401-050 Ø 0,50 mm



EVES

037-410-280 28,0 cm / 11"



EVES

037-412-280 28,0 cm / 11"

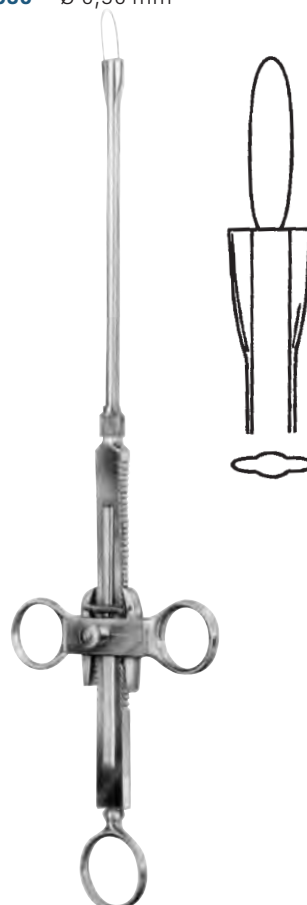

BRUENINGS

037-414-280 28,0 cm / 11"



RÖDER

037-416-265 26,5 cm / 10 1/2"



037

Tonsillotome
Tonsillectomes
Amigdalòtomos
Tonsillotomi

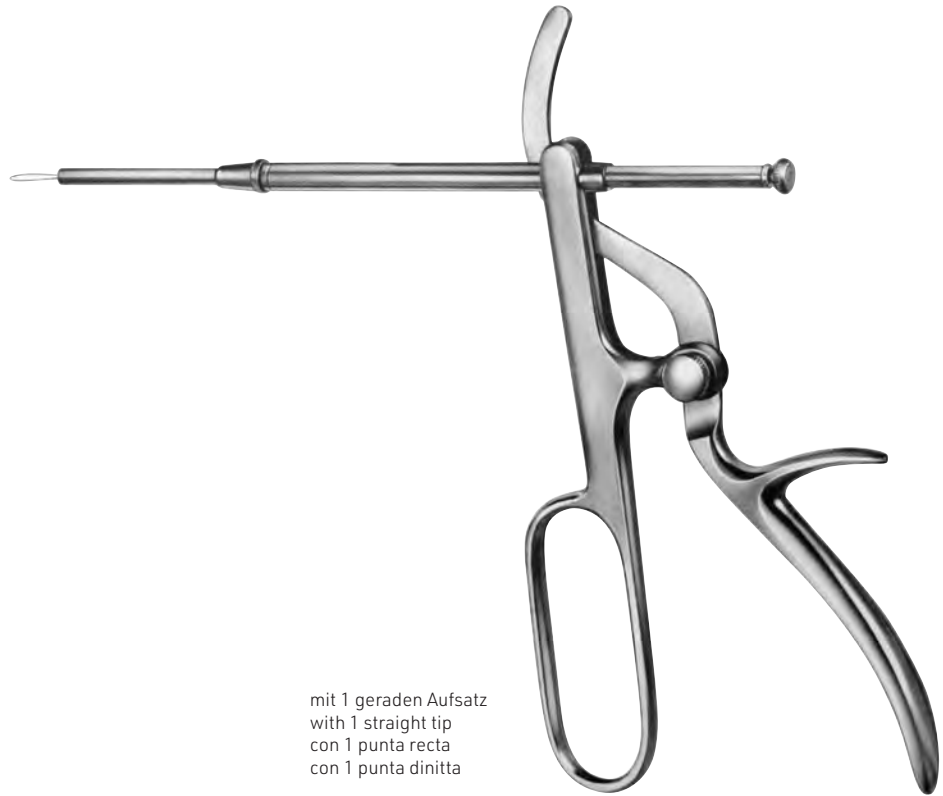

mit 1 geraden Aufsatz
with 1 straight tip
con 1 punta recta
con 1 punta dritta

TYDING

037-420-001

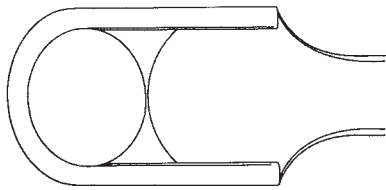

SLUDDER-BALLENGER

037-431-001 Fig.1

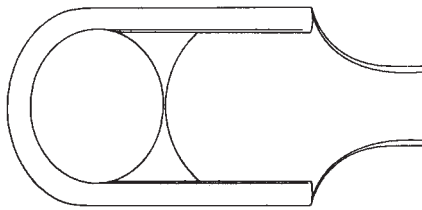

SLUDDER-BALLENGER

037-431-002 Fig.2

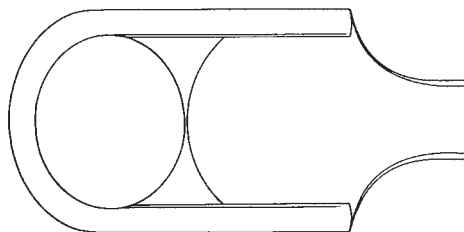

SLUDDER-BALLENGER

037-431-003 Fig.3



SLUDDER-BALLENGER

037-430-010

Griff alleine
handle only
mango suelto
manico solo

SLUDDER-BALLENGER

037-430-003

komplett mit 3 Aufsätzen
complete with 3 tips
completo con 3 puntas
completo con 3 punti



HARTMANN

037-435-013 - 037-435-017

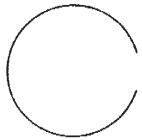

037-435-013 Ø 13 mm

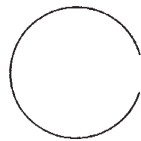

037-435-015 Ø 15 mm

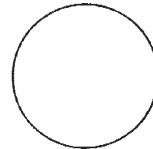

037-435-017 Ø 17 mm



037

Broncho-Oesophaguskopiezangen
Broncho-Esophagoscopy Forceps
Pinzas para Bronco-Esofagoscopia
Pize per Broncho-Esofagoscopia



CHEVALIER-JACKSON

037-440-300 - 037-446-600



Fig. 1

037-440-300	30,0 cm
037-440-400	40,0 cm
037-440-500	50,0 cm
037-440-600	60,0 cm



Fig. 2

037-441-300	30,0 cm
037-441-400	40,0 cm
037-441-500	50,0 cm
037-441-600	60,0 cm



Fig. 3

037-442-300	30,0 cm
037-442-400	40,0 cm
037-442-500	50,0 cm
037-442-600	60,0 cm



Fig. 4

037-443-300	30,0 cm
037-443-400	40,0 cm
037-443-500	50,0 cm
037-443-600	60,0 cm



Fig. 5

037-444-300	30,0 cm
037-444-400	40,0 cm
037-444-500	50,0 cm
037-444-600	60,0 cm



Fig. 6

037-445-300	30,0 cm
037-445-400	40,0 cm
037-445-500	50,0 cm
037-445-600	60,0 cm



Fig. 7

037-446-300	30,0 cm
037-446-400	40,0 cm
037-446-500	50,0 cm
037-446-600	60,0 cm



HUBER

037-450-001

Universal-Griff
Universal Handle
Mango universal
Manico universale



BRUENINGS

037-452-200	20,0 cm / 8"
037-452-300	30,0 cm / 12"
037-452-400	40,0 cm / 16"

Verlängerungsrohr für Handgriff Art.-Nr. 037-450-001
Interchangeable Tube for handle ref. 037-450-001
Tubo de extensión para mango ref. 037-450-001
Tube allunghi per manico rif..037-450-001

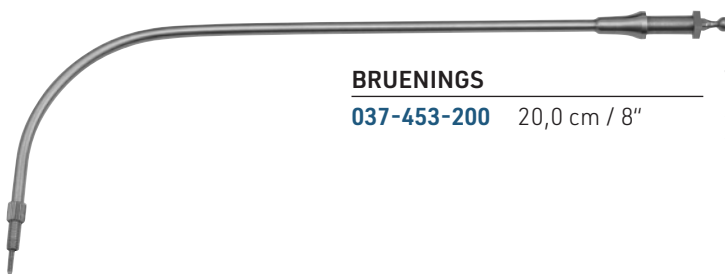

BRUENINGS

037-453-200	20,0 cm / 8"
--------------------	--------------

Verlängerungsrohr gebogen für Handgriff Art.-Nr. 037-450-001
Interchangeable Tube, curved for handle ref. 037-450-001
Tubo de extensión, curva para mango ref. 037-450-001
Tube allunghi, curva per manico rif..037-450-001



FRAENKEL
 037-456-001



SEIFFERT
 037-458-001



FRAENKEL
 037-460-001



SCHEINMANN
 037-461-001



SCHEINMANN
 037-463-001



BRUENINGS
 037-464-003
 037-464-004



BRUENINGS
 037-466-002
 037-466-003



LANGE
 037-468-001



KRAUSE
 037-470-001
 037-470-002



KRAUSE
 037-472-001



CORDES
 037-474-001
 037-474-002
 037-474-003
 037-474-004



SCHUMACHER
 037-476-001



CORDES
 037-478-001
 037-478-002



CORDES
 037-480-001



ROSENBERG
 037-482-001



037

Kehlkopfpolypenzange, Deckenhalter
Laryngeal Polypus Forceps, Epiglottis Retractor
Pinza para pólipos laringeos, Depresor para epíglotis
Pinze per polipi laringei, Depressore per epiglottide



037-485-001

nach rechts öffnend
opening to right side
abriendo hacia la derecha
aprente verso
destra



037-485-002

nach links öffnend
opening to left side
abriendo hacia la izquierda
aprente verso sinistra



037-485-003

nach unten öffnend
opening down-ward
abriendo hacia abajo
aprente in basso



037-485-004

nach oben öffnend
opening up-ward
abriendo hacia arriba
aprente in alto

JURASZ

037-485-001 - 037-485-004

23,0 cm / 9"



REICHERT

037-487-240 24,0 cm / 9 1/2"

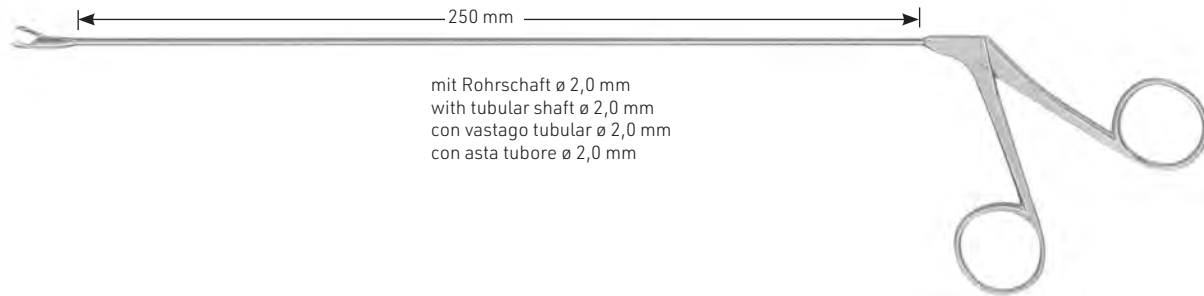

mit Rohrschaft ø 2,0 mm
 with tubular shaft ø 2,0 mm
 con vastago tubular ø 2,0 mm
 con asta tubore ø 2,0 mm

037-490-001 - 037-494-004



gerade
 straight
 recta
 retta

037-490-001

Löffel rund ø 2,5 mm
 round cup ø 2,5 mm
 Cuchara redonda ø 2,5 mm
 Cucchiario rotondo ø 2,5 mm



links gebogen
 curved left
 curva izquierda
 curva sinistra

037-490-002

Löffel rund ø 2,5 mm
 round cup ø 2,5 mm
 Cuchara redonda ø 2,5 mm
 Cucchiario rotondo ø 2,5 mm



rechts gebogen
 curved right
 curva derecha
 curva destra

037-490-003

Löffel rund ø 2,5 mm
 round cup ø 2,5 mm
 Cuchara redonda ø 2,5 mm
 Cucchiario rotondo ø 2,5 mm



aufgebogen
 angled upward
 curva hacia arriba
 curva in alto

037-490-004

Löffel rund ø 2,5 mm
 round cup ø 2,5 mm
 Cuchara redonda ø 2,5 mm
 Cucchiario rotondo ø 2,5 mm



gerade
 straight
 recta
 retta

037-492-001



links gebogen
 curved left
 curva izquierda
 curva sinistra

037-492-002



rechts gebogen
 curved right
 curva derecha
 curva destra

037-492-003



gerade
 straight
 recta
 retta

037-494-001



links gebogen
 curved left
 curva izquierda
 curva sinistra

037-494-002



rechts gebogen
 curved right
 curva derecha
 curva destra

037-494-003



aufgebogen
 angled upward
 curva hacia arriba
 curva in alto

037-494-004



037

Kehlkopfspiegel, Spiegelgriffe
 Laryngeal Mirrors, Mirror Handles
 Espejos laringeales, Mangos para espejos
 Specchi laringei, Manico per specchi



mit festem Handgriff
 with fixed handle
 con mango fijo
 con manico fisso

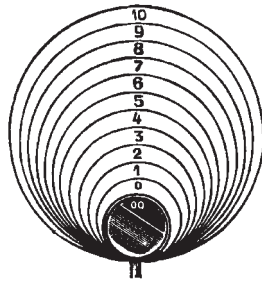

ohne Handgriff
 without handle
 sin mango
 senza manico



Ø 12 mm
037-505-012

Ø 14 mm
037-505-014

Ø 16 mm
037-505-016

Ø 18 mm
037-505-018

037-501-008	Fig. 00 = 8 mm Ø	037-503-008
037-501-010	Fig. 0 = 10 mm Ø	037-503-010
037-501-012	Fig. 1 = 12 mm Ø	037-503-012
037-501-014	Fig. 2 = 10 mm Ø	037-503-014
037-501-016	Fig. 3 = 16 mm Ø	037-503-016
037-501-018	Fig. 4 = 18 mm Ø	037-503-018
037-501-020	Fig. 5 = 20 mm Ø	037-503-020
037-501-022	Fig. 6 = 22 mm Ø	037-503-022
037-501-024	Fig. 7 = 24 mm Ø	037-503-024
037-501-026	Fig. 8 = 26 mm Ø	037-503-026
037-501-028	Fig. 9 = 28 mm Ø	037-503-028
037-501-030	Fig. 10 = 30 mm Ø	037-503-030

MICHEL

25,0 cm / 10"



037-506-100 10,0 cm



037-510-120 12,0 cm

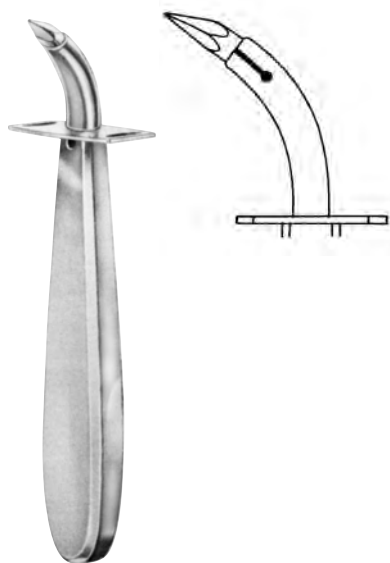

UECKERMANN

13,0 cm / 5"



037-601-075 Ø 7,5 mm



037-601-090 Ø 9 mm



LABORDE

037-605-140 14,0 cm / 5½"



TROUSSEAU

037-609-120 12,0 cm / 4¾"
037-609-140 14,0 cm / 5½"



037

Tracheal-Häkchen
Tracheal Hooks
Ganchos traqueales
Uncini tracheali



spitz
sharp
agudo
acuto

037-621-170



stumpf
blunt
romo
smusso

037-623-170

ITERSON

17,0 cm / 6 1/4"



links
left
izquierda
sinistra

BOSE

037-625-160 16,0 cm / 6 1/4"



rechts
right
derecha
destra

BOSE

037-627-160 16,0 cm / 6 1/4"



ROSE

037-629-135 13,5 cm / 5"

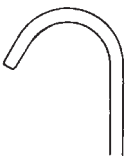

LUER

037-631-110 11,0 cm / 4 1/2"



JACKSON

037-635-150 15,0 cm / 6"

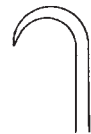

spitz
sharp
agudo
acuto

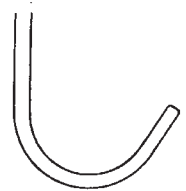

ROSE

037-637-150 15,0 cm / 6"

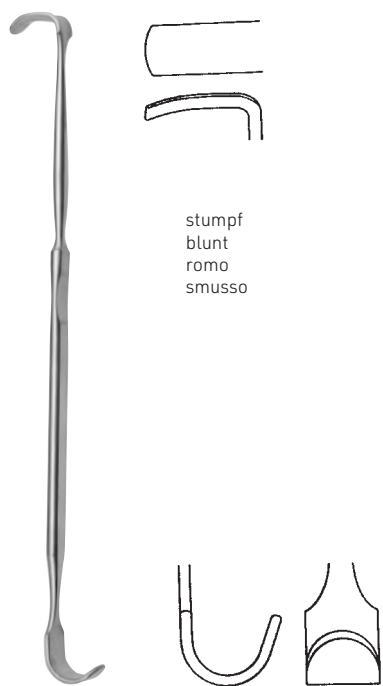

stumpf
blunt
romo
smusso

LUKENS

037-641-170 17,0 cm / 6³/₄"



JACKSON

037-643-170 17,0 cm / 6³/₄"

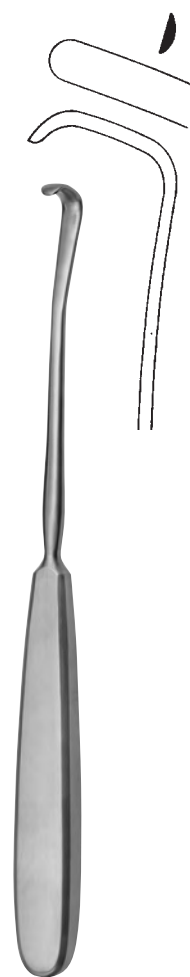

SCHOENBORN

037-645-210 21,0 cm / 8¹/₄"



037

Tracheal-Kanülen
Tracheal Tubes
Cánulas traqueales
Cannule tracheali

Material: Edelstahl
Material: Stainless Steel
Material: acero inoxidable
Materiale: acciaio inossidabile

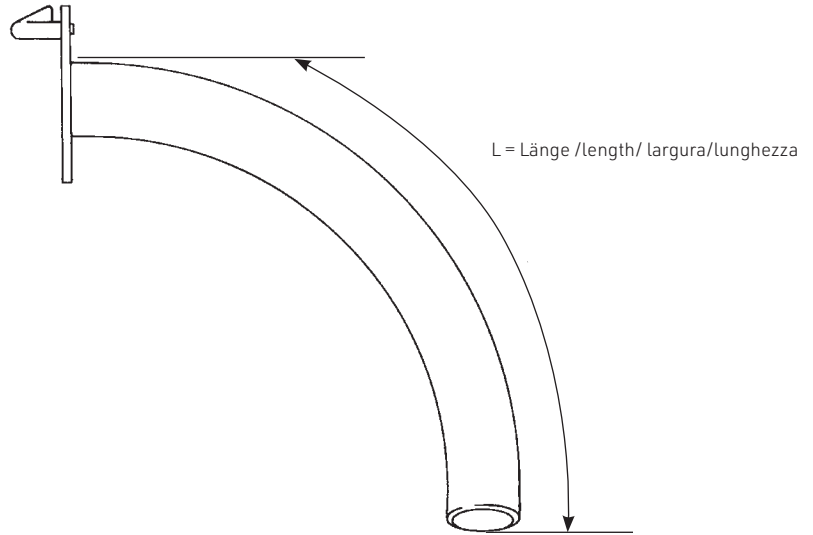

LUER		L	
037-701-004	Fig. 0	Ø 4 mm	45 mm
037-701-005	Fig. 1	Ø 5 mm	50 mm
037-701-006	Fig. 2	Ø 6 mm	55 mm
037-701-007	Fig. 3	Ø 7 mm	60 mm
037-701-008	Fig. 4	Ø 8 mm	65 mm
037-701-009	Fig. 5	Ø 9 mm	70 mm
037-701-010	Fig. 6	Ø 10 mm	75 mm
037-701-011	Fig. 7	Ø 11 mm	80 mm
037-701-012	Fig. 8	Ø 12 mm	85 mm
037-701-013	Fig. 9	Ø 13 mm	90 mm



CHEVALIER-JACKSON		L	
037-711-004	Fig. 0	Ø 4 mm	45 mm
037-711-005	Fig. 1	Ø 5 mm	50 mm
037-711-006	Fig. 2	Ø 6 mm	55 mm
037-711-007	Fig. 3	Ø 7 mm	60 mm
037-711-008	Fig. 4	Ø 8 mm	65 mm
037-711-009	Fig. 5	Ø 9 mm	70 mm
037-711-010	Fig. 6	Ø 10 mm	75 mm
037-711-011	Fig. 7	Ø 11 mm	80 mm
037-711-012	Fig. 8	Ø 12 mm	85 mm
037-711-013	Fig. 9	Ø 13 mm	90 mm



037-851-150



037-853-150

KOCHER

037-851-150 - 037-853-150

15,0 cm / 6"



KOCHER

037-855-180

18,0 cm / 7"



037

Kropffaßzangen, Klemme
Goitre Grasping Forceps, Clamps
Pinzas para coger el bocio, Clamp para musculos
Pinze per gozzo, Pinza



LAHEY

037-860-150 15,0 cm / 6"

037-860-200 20,0 cm / 8"



037-860-150

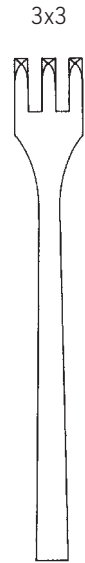

037-860-200



MASTIN

037-865-170 17,0 cm / 7"

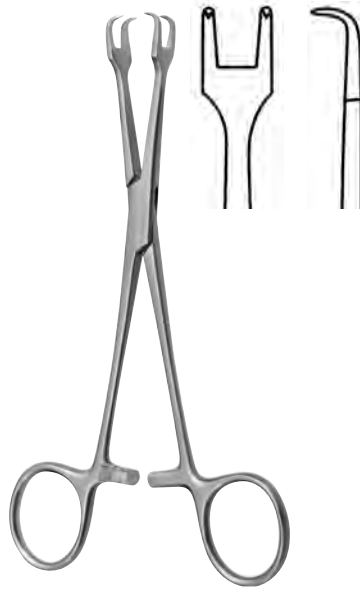

LAHEY

037-868-150 15,0 cm / 6"



BRAUN

037-870-150 15,0 cm / 6"

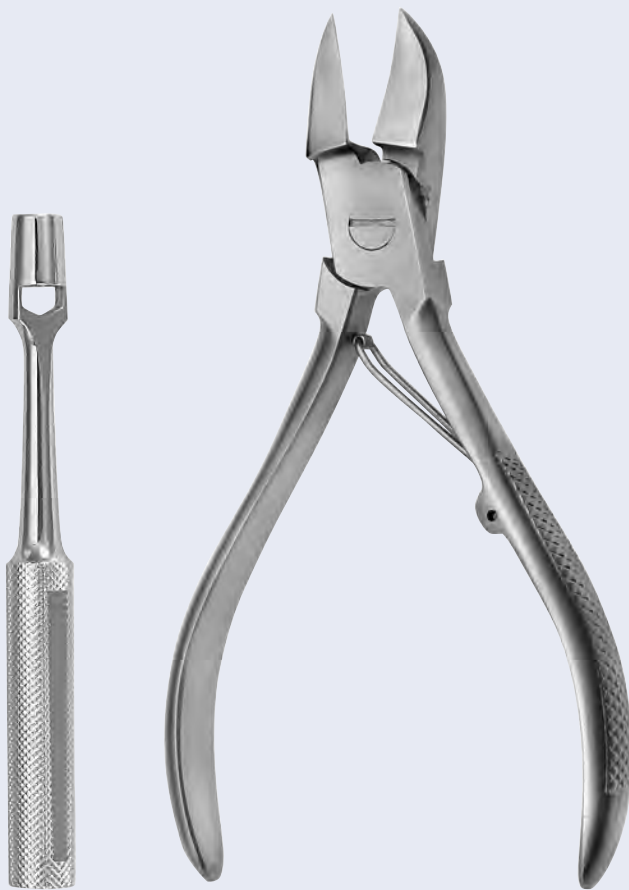

046

Dermatologie
Dermatology
Dermatología
Dermatologia



046

Lupusküretten, Hauthäkchen
Lupus Currettes, Skin Hooklets
Curetas para lupus, Ganchitos para piel
Curette per lupus, Uncini cutanei



Lupusschaber
Lupus Scraper
Rascador para lupus
Raschiatoio per lupus

VIDAL

046-111-140 14,0 cm / 5 1/2"



3,0 mm

4,0 mm



Fig.1

Fig.2

046-120-001

046-120-002

5,0 mm

6,0 mm



Fig.3

Fig.4

046-120-003

046-120-004

FOX

046-120-001 - 046-120-004 14,0 cm / 5 1/2"



Fig.1

Fig.2

046-130-001

046-130-002



Fig.3

Fig.4

046-130-003

046-130-004



Fig.5

Fig.6

046-130-005

046-130-006

WOLFF

046-130-001 - 046-130-006 14,0 cm / 5 1/2"



scharf
sharp
agudo
acuto

KILNER

046-140-150 15,0 cm / 6"

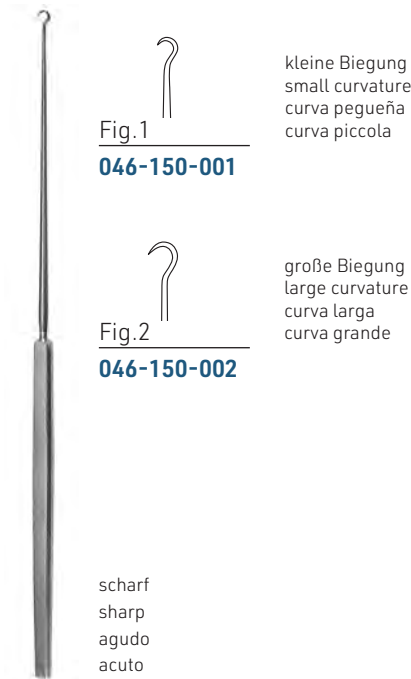

Fig.1
 046-150-001
 kleine Biegung
 small curvature
 curva pequeña
 curva piccola

Fig.2
 046-150-002
 große Biegung
 large curvature
 curva larga
 curva grande

scharf
 sharp
 agudo
 acuto

GILLIES

046-150-001 - 046-150-002 18,0 cm / 7"

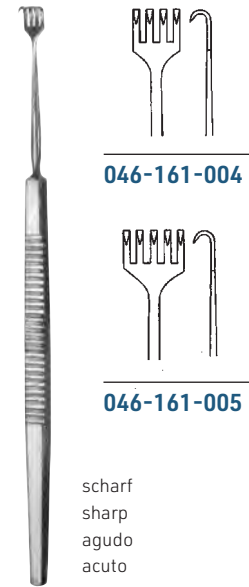

046-161-004

046-161-005

scharf
 sharp
 agudo
 acuto

KAYE

046-161-004 - 046-161-005 13,0 cm / 5"

Trephinensatz komplett auf Platte mit Griff
 und 6 auswechselbaren Trephinen

Punch Set complete on plate with handle and
 6 exchangeable Punches

Juego de trepanos para piel completo en chapa
 con mango y 6 trépanos cambiables

Serie di trefine cutanee completo in lastra con
 manico e 6 trefine cambiabile

046-170-001

Griff allein
 Handle only
 Mango suelto
 Manico solo

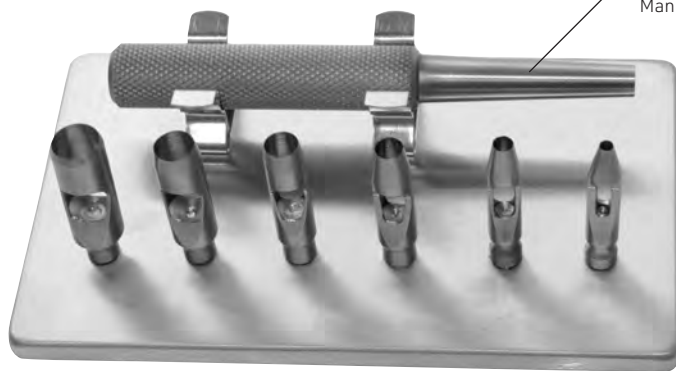

KEYES

046-170-000

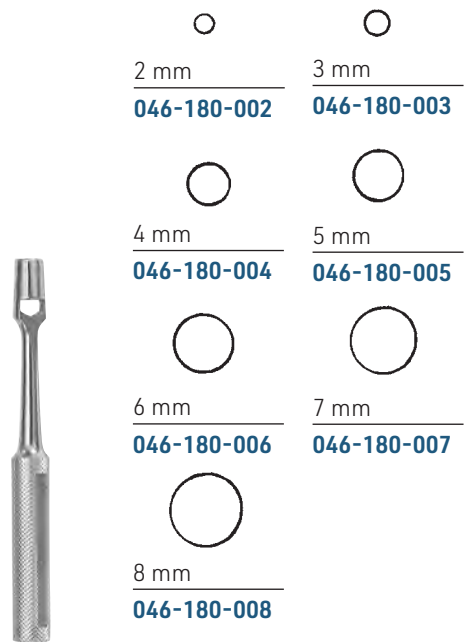
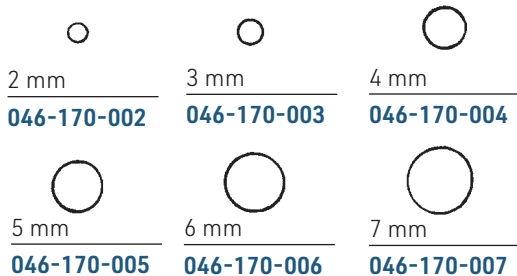

KEYES

046-180-002 - 046-180-008 12,0 cm / 4³/₄"



046

Komedoneninstrumente
Comedone Extractors
Extractores para comedones
Tiracomedoni

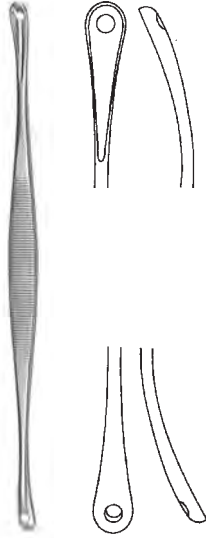

UNNA
046-201-140 14,0 cm / 5 1/2"



UNNA
046-203-140 14,0 cm / 5 1/2"



SAALFELD
046-205-100 10,0 cm / 4"

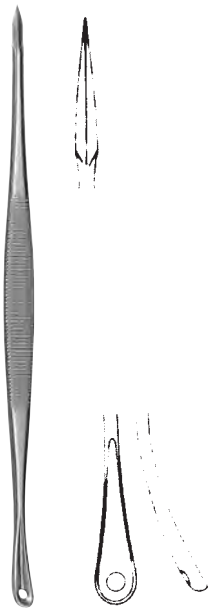

SAALFELD
046-207-140 14,0 cm / 5 1/2"

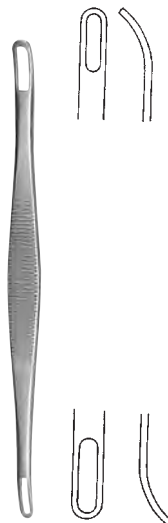

SCHAMBERG
046-209-100 10,0 cm / 4"



KATSCH
046-211-140 14,0 cm / 5 1/2"

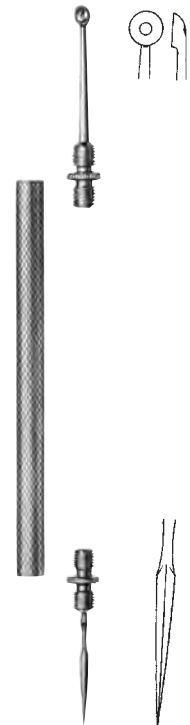

UNNA-VIDAL
046-215-115 11,5 cm / 4 1/2"



046-410-110 11,0 cm / 4¹/₃"

Feile alleine
file only
lima suelta
lima sola

046-303-500 50,0 cm / 19¹/₂"

Kette alleine
chain only
cadena suelta
catena sola



gerade
straight
recta
retta



gebogen
curved
curva
curva

046-304-100 10,0 cm / 4"

046-305-090 9,0 cm / 3¹/₂"
046-305-100 10,0 cm / 4"

046-301-110

Schwesterngarnitur, bestehend aus Nagelschere (gebogen) und Nagelfeile, mit Kette
Hospital Nurse Set, consisting of nail scissors (curved) and nail file, with chain
Juego de manicura para enfermeras, compuesto de tijeras (curva) y lima para uñas, con cadena
Set di manicura per infermieri, composto di forbici (curva) e lima per unghie, con catena

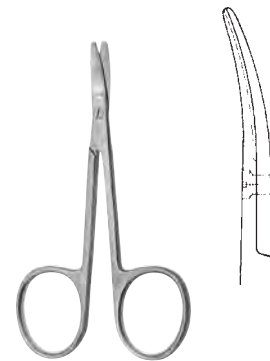

046-307-085 8,5 cm / 3¹/₂"



046-310-095



046-311-095



046-311-105

046-310-095 - 046-311-095 9,5 cm / 3³/₄"
046-311-105 10,5 cm / 4¹/₄"



046

Nagelzangen
Nail Nippers
Pinzas para cortar uñas
Tronchesine per unghie



046-321-140 14,0 cm / 5¹/₂"



046-324-140 14,0 cm / 5¹/₂"

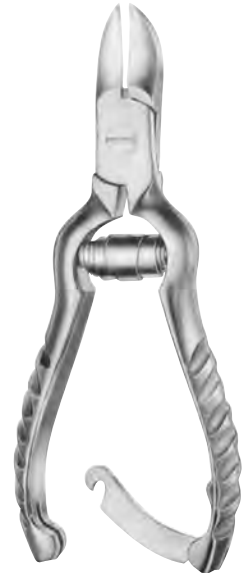

TURNBULL

046-325-110 11,0 cm / 4³/₈"
046-325-130 13,0 cm / 5"



046-329-130 13,0 cm / 5"



046-331-120 12,0 cm / 4³/₄"



gerade Schneiden
 straight cutting edges
 hojas cortantes rectas
 parte tagliente diritta

046-334-110 11,0 cm / 4¹/₂"
046-334-130 13,0 cm / 5"
046-334-150 15,0 cm / 6"



046-335-110 11,0 cm / 4¹/₂"

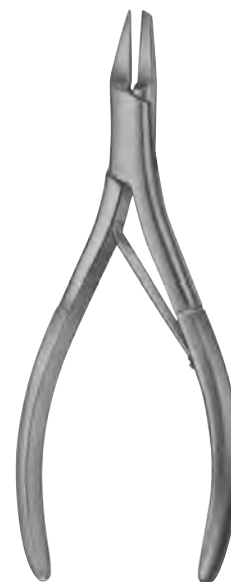

046-338-135 13,5 cm / 5¹/₄"

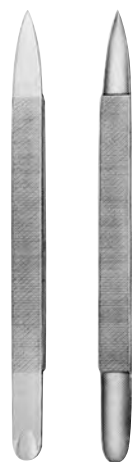

046-400-120 12,0 cm / 4³/₄"



046-410-110 11,0 cm / 4¹/₂"



mit Saphirbelag
 with sapphire coating
 con recubrimiento de zafiro
 con rivestimento in zaffiro

046-420-160 16,0 cm / 6¹/₄"



046



085

Sterilisation, Hygiene,
Aufbewahrung
Sterilisation, Hygiene,
Storage
Esterilización, Higiene,
Almacenaje
Sterillizzazione,
Magazzinaggio



085

Handwaschbürste, Bürstenspender
Hand and nail brush, brush dispenser
Cepillo para uñas, dispensadores de cepillos
Spazzola per unghie, Distributore per spazzole

mehr als 400 x autoclavierbar
more than 400 x autoclavable
más que 400 x autoclavable
sterilizzabile più di 400 volte in autoclave



ASEPTIC

085-100-001

Kunststoff
plastic
plástico
plastico



085-150-250 25,0 cm / 9³/₄"

Standgefäß 20,5 cm hoch
mit 25 cm langer Kornzange

jar 20,5 cm high
with 25 cm long dressing forceps

tarro 20,5 de altura
con pinza de vendaje de 25 cm

contenitore 20,5 cm di altezza
con pinza per medicatura die 25 cm di lunghezza



085-150-320 32,0 cm / 12¹/₂"

Standgefäß 25,5 cm hoch
mit 32 cm langer Kornzange

jar 25,5 cm high
with 32 cm long dressing forceps

tarro 25,5 de altura
con pinza de vendaje de 32 cm

contenitore 25,5 cm di altezza
con pinza per medicatura die 32 cm di lunghezza



085

Sterilisierzangen
Sterilizing Forceps
Pinzas para esterilizaci3n
Pinze per strumenti sterilizzati



CHEATTLE

085-155-270 27,0 cm / 10¹/₂"



085-158-200 20,0 cm / 8"
085-158-300 30,0 cm / 11³/₄"

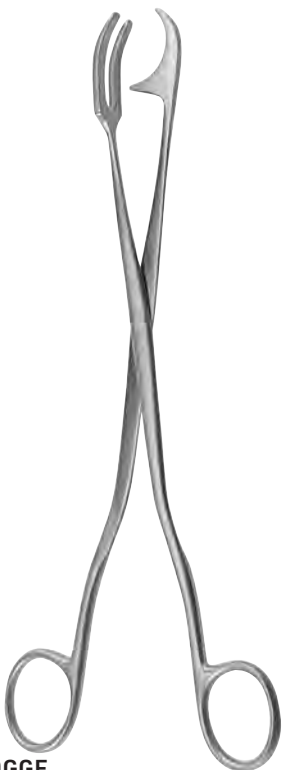

ROGGE

085-160-235 23,5 cm / 9¹/₄"

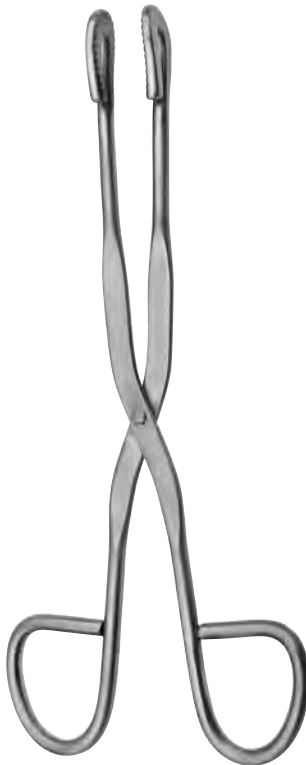

UNIVERSAL

085-164-200 20,0 cm / 8"
085-164-280 28,0 cm / 11"



UNIVERSAL

085-165-200 20,0 cm / 8"
085-165-280 28,0 cm / 11"

Sterilisierklammern, Schlauchklemmen, Quetschhähne
Safety Pins, Pinchcocks, Tubing clamps
Imperdibles para esterilizaciòn, Cierra-tubos
Spilli di sicurezza per sterilizzazione, Morsetti per tubi



085



BUNT

085-170-120 12,0 cm / 4³/₄"



MAYO

085-172-140 14,0 cm / 5¹/₂"



DEPONETTE

085-200-035 245 x 135 x 35 mm

Boden perforiert, mit Textilfilter (085-207-230)
 perforated bottom, with textile filter (085-207-230)
 fondo perforado, con filtro de tejido (085-207-230)
 fondo perforato, con filtri tessili (085-207-230)



DEPONETTE

085-200-050 245 x 135 x 50 mm

Boden perforiert, mit Textilfilter (085-207-230)
 perforated bottom, with textile filter (085-207-230)
 fondo perforado, con filtro de tejido (085-207-230)
 fondo perforato, con filtri tessili (085-207-230)

Deckel und Boden perforiert, mit Scharnierdeckel
 perforated lid and bottom, with hinged lid
 tapa y fondo perforado, con tapa de bisagra
 coperchio e fondo perforati, con coperchio a cerniera



Behälter Cases Cajas Scatole	Abmessung Sizes Tamaños Dimensione	Ersatz-Textilfilter, Packung mit 5 Paar Spare Textile Filters, package of 5 pairs Filtros de tejido de recambio, paquete con 5 pares Filtri di tessuti di ricambio, pacchetto con 5 paia
085-202-230	230 x 130 x 50 mm	085-207-230
085-202-260	260 x 150 x 50 mm	085-207-260
085-202-275	275 x 235 x 50 mm	085-207-275
085-202-300	300 x 200 x 50 mm	085-207-300
085-202-325	325 x 275 x 50 mm	085-207-325
085-202-420	420 x 175 x 50 mm	085-207-420
085-204-230	230 x 130 x 75 mm	085-207-230
085-204-260	260 x 150 x 75 mm	085-207-260
085-204-300	300 x 200 x 75 mm	085-207-300
085-204-325	325 x 275 x 75 mm	085-207-325
085-204-420	420 x 175 x 75 mm	085-207-420



085

Silikonmatten
Silicone Mats
Alfombras de silicona
Stuoia in silicone

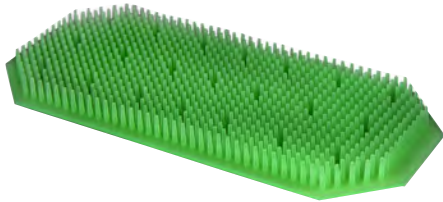

099-210-270 270 x 125 mm

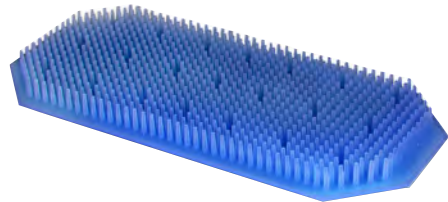

099-211-270 270 x 125 mm

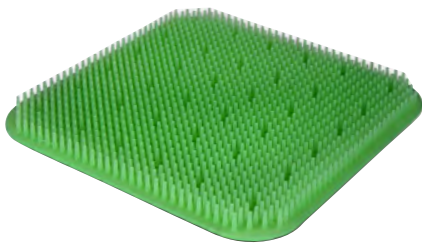

099-212-245 245 x 245 mm

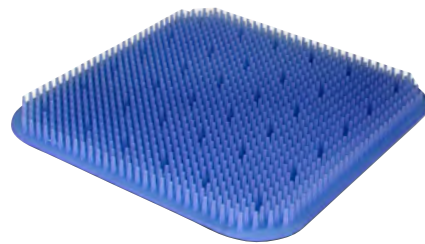

099-213-245 245 x 245 mm

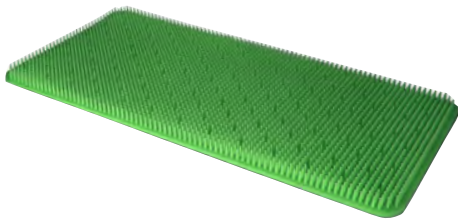

099-214-220 220 x 230 mm
099-214-380 380 x 230 mm
099-214-440 440 x 230 mm
099-214-520 520 x 230 mm

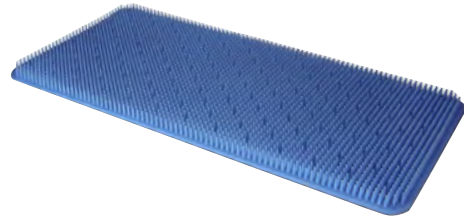

099-215-220 220 x 230 mm
099-215-380 380 x 230 mm
099-215-440 440 x 230 mm
099-215-520 520 x 230 mm

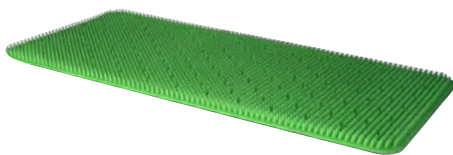

099-216-150 300 x 150 mm
099-216-300 300 x 300 mm

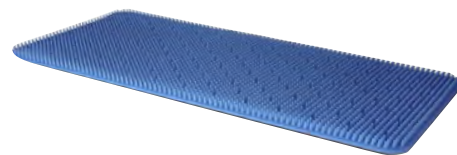

099-217-150 300 x 150 mm
099-217-300 300 x 300 mm



099-218-545 545 x 255 mm

Die Matte kann auf das gewünschte Maß zugeschnitten werden
The mat can be cut to the desired dimensions
La alfombra se puede cortar hasta la medida deseada
La stuoia può essere tagliato a misura desiderata

Rückseite
Back side
Dorso
Retro



Drahtgeflecht
wire mesh
malla de alambre
griglia in metallo

095-220-030	540 x 255 x 30 mm
095-220-050	540 x 255 x 50 mm
095-220-070	540 x 255 x 70 mm
095-220-100	540 x 255 x 100 mm



Drahtgeflecht
wire mesh
malla de alambre
griglia in metallo



Drahtgeflecht
wire mesh
malla de alambre
griglia in metallo

095-222-030	485 x 255 x 30 mm
095-222-050	485 x 255 x 50 mm
095-222-070	485 x 255 x 70 mm
095-222-100	485 x 255 x 100 mm

095-224-030	405 x 255 x 30 mm
095-224-050	405 x 255 x 50 mm
095-224-070	405 x 255 x 70 mm
095-224-100	405 x 255 x 100 mm



Drahtgeflecht
wire mesh
malla de alambre
griglia in metallo

095-226-030	255 x 245 x 30 mm
095-226-050	255 x 245 x 50 mm
095-226-070	255 x 245 x 70 mm
095-226-100	255 x 245 x 100 mm



085

Steriliskörbe
Sterilizing Baskets
Cestas para esterilización
Cestelli per sterilizzazione

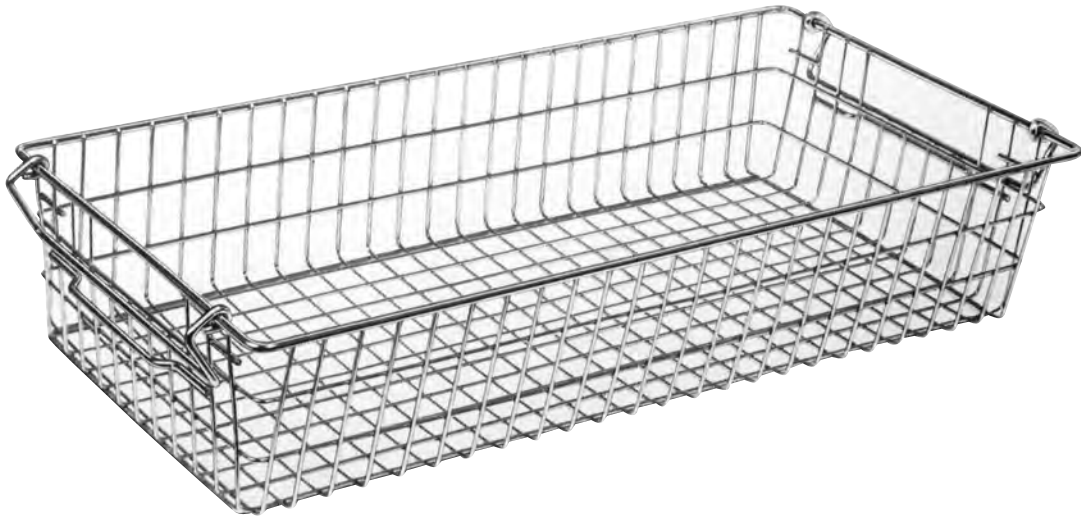

085-230-130 600 x 300 x 130 mm

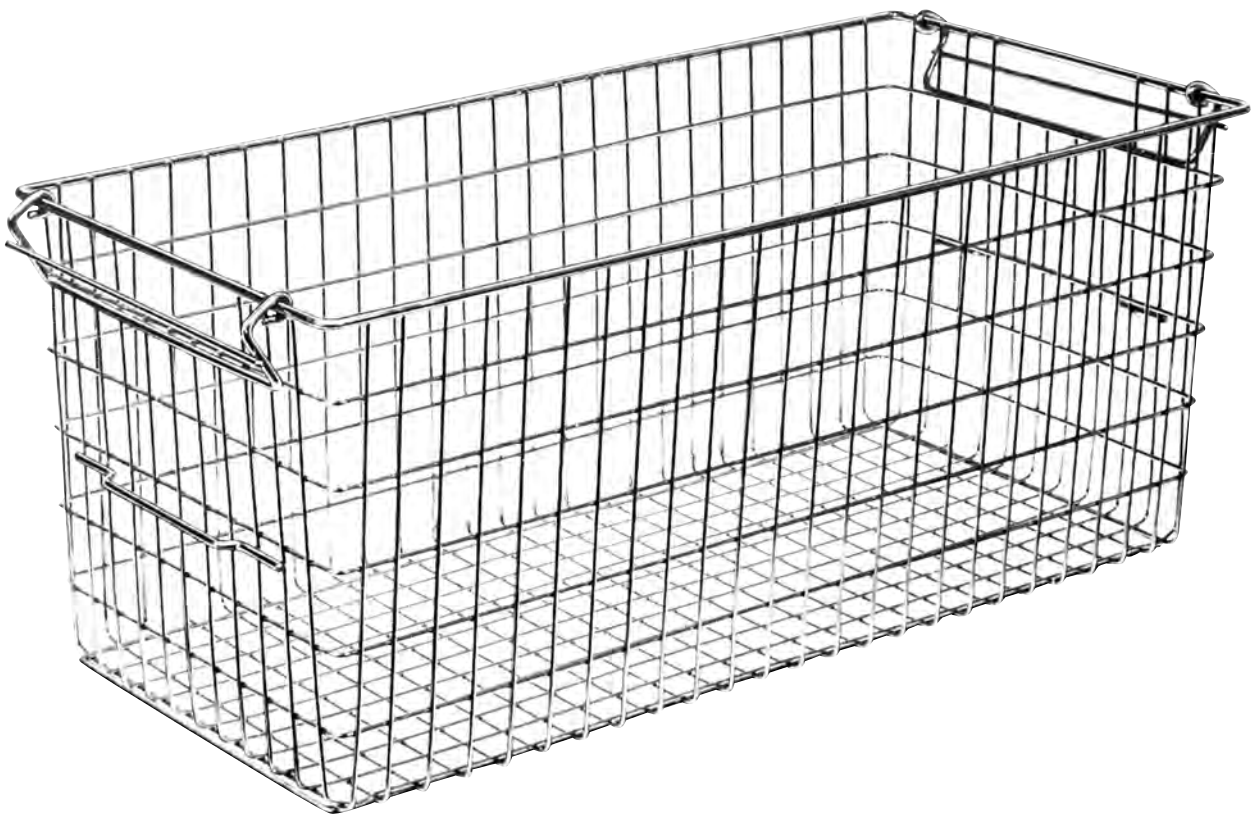

085-230-260 600 x 300 x 260 mm

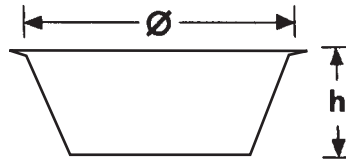

Ø x h

085-300-005	Ø 40 x 19 mm	0,05 l
085-300-007	Ø 61 x 30 mm	0,07 l
085-300-014	Ø 80 x 40 mm	0,14 l
085-300-035	Ø 116 x 50 mm	0,35 l
085-300-045	Ø 128 x 55 mm	0,45 l
085-300-070	Ø 147 x 65 mm	0,70 l
085-300-110	Ø 167 x 75 mm	1,10 l
085-300-160	Ø 187 x 85 mm	1,60 l



Ø x h

085-310-030	Ø 116 x 35 mm	0,30 l
085-310-040	Ø 128 x 38 mm	0,40 l
085-310-050	Ø 147 x 40 mm	0,50 l
085-310-075	Ø 157 x 45 mm	0,75 l
085-310-100	Ø 187 x 45 mm	1,00 l



Ø x h

085-312-015	Ø 110 x 28 mm	0,15 l
--------------------	---------------	--------



innen graduiert
 graduated inside
 graduado en el interior
 graduato all'interno

Ø x h

085-314-010	100 ccm	0,1 l
--------------------	---------	-------



innen graduiert
 graduated inside
 graduado en el interior
 graduato all'interno

085-320-025	0,25 l
085-320-050	0,50 l
085-320-100	1,00 l
085-320-200	2,00 l



085

Runde Schüsseln, Flachschen
Round bowls, Flat Dishes
Cubetas redondas, Cubetas planas
Scodelle rotonde, Scodelle piatte

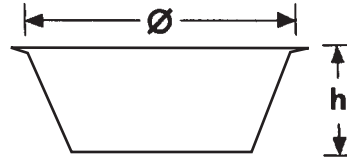

Ø x h

085-330-075	Ø 150 x 74 mm	0,75 l
085-330-100	Ø 160 x 65 mm	1,00 l
085-330-200	Ø 220 x 70 mm	2,00 l
085-330-300	Ø 240 x 95 mm	3,00 l
085-330-450	Ø 260 x 130 mm	4,50 l
085-330-600	Ø 300 x 105 mm	6,00 l
085-330-850	Ø 320 x 140 mm	8,50 l
085-334-380	Ø 380 x 125 mm	11,00 l
085-334-400	Ø 400 x 150 mm	14,00 l



Ø x h

085-342-020	Ø 110 x 27 mm	0,20 l
085-342-030	Ø 110 x 40 mm	0,30 l



Ø x h

085-340-600	Ø 330 x 90 mm	6,00 l
085-340-800	Ø 330 x 115 mm	8,00 l

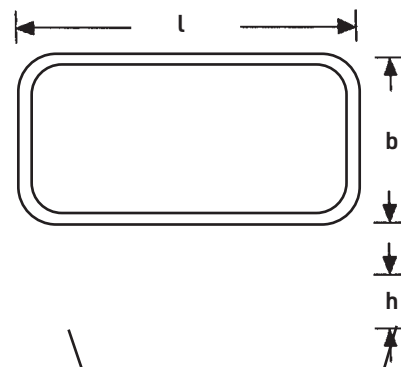

$l \times b \times h$

085-350-155	230 x 155 x 30 mm
085-350-175	300 x 175 x 30 mm
085-352-175	300 x 175 x 40 mm
085-352-240	350 x 240 x 36 mm
085-352-300	400 x 300 x 50 mm



$l \times b \times h$

085-354-160	210 x 160 x 10 mm
085-354-180	240 x 180 x 10 mm
085-356-150	310 x 150 x 10 mm
085-356-210	310 x 210 x 10 mm
085-356-240	350 x 240 x 10 mm
085-356-270	400 x 270 x 20 mm
085-356-280	420 x 280 x 10 mm



085

Mehrzweckschalen, Runde Schüsseln, Standgefäße
Universal Trays, Round Bowls, Metal Jars
Bandejas universales, Cubetas redondas, Tarros metálicos
Bacinnelle universali, Scodelle rotonde, Recipienti metallici

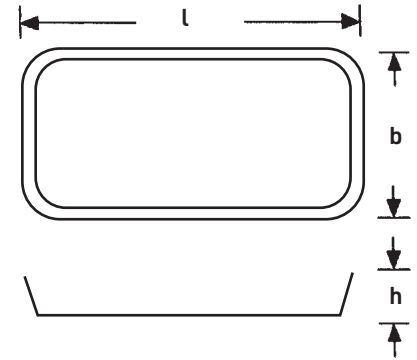

l x b x h

085-358-235 235 x 190 x 40 mm

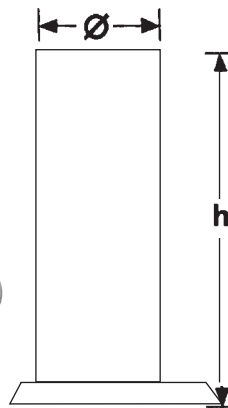

Deckel allein, geschlossen
Lid only, closed
Tapa suelta, cerrada
Coperchio solo, chiuso

085-376-050 Ø 50 mm
085-376-075 Ø 75 mm
085-376-100 Ø 100 mm

Ø x h

085-370-090 Ø 30 x 90 mm
085-370-100 Ø 50 x 100 mm
085-370-130 Ø 50 x 130 mm
085-370-175 Ø 50 x 175 mm
085-372-100 Ø 75 x 100 mm
085-372-130 Ø 75 x 130 mm
085-372-175 Ø 75 x 175 mm
085-374-175 Ø 100 x 175 mm
085-374-200 Ø 100 x 200 mm



mit Knopfdeckel
 lid with knob
 tapa con botòn
 con coperchio a bottone



Deckel ohne Knopf
 lid without knob
 tapa sin botòn
 coperchio senza bottone

l x b x h

085-400-165	165 x 85 x 35 mm
085-400-200	200 x 100 x 35 mm
085-402-200	200 x 100 x 50 mm
085-402-230	230 x 130 x 50 mm
085-402-260	260 x 150 x 50 mm
085-402-270	270 x 235 x 50 mm
085-402-300	300 x 200 x 50 mm
085-402-325	325 x 275 x 50 mm

l x b x h

085-410-165	165 x 85 x 35 mm
085-410-200	200 x 100 x 35 mm
085-412-200	200 x 100 x 50 mm
085-412-230	230 x 130 x 50 mm
085-412-260	260 x 150 x 50 mm
085-412-270	270 x 235 x 50 mm
085-412-300	300 x 200 x 50 mm
085-412-325	325 x 275 x 50 mm

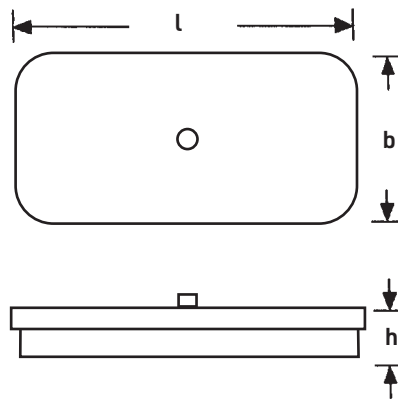



085

Runde Metalldosen, Medizinbecher
 Round Metal Boxes, Medicine cups
 Cajas metálicas redondas, Vasos medicinales
 Scatole per strumenti, Bicchieri per medicina



mit Knopfdeckel
 lid with knob
 tapa con botón
 con coperchio a bottone

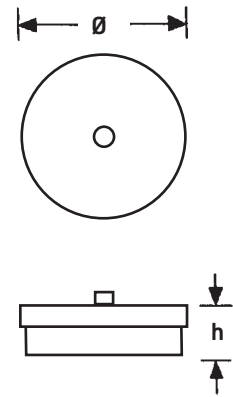

Ø x h

085-420-060	Ø 75 x 60 mm
085-420-075	Ø 75 x 75 mm
085-422-060	Ø 100 x 60 mm
085-422-100	Ø 100 x 100 mm
085-424-080	Ø 125 x 80 mm
085-424-125	Ø 125 x 125 mm
085-426-150	Ø 150 x 150 mm



085-430-025 25 ccm

innen graduert
 graduated inside
 graduado en el interior
 graduato all'interno



085-432-050 50 ccm

innen graduert
 graduated inside
 graduado en el interior
 graduato all'interno



085-434-020 20 ccm

Medizinlöffel
 Medicine Spoon
 Cuchara medicinal
 Cucchiaino per medicina

innen graduert
 graduated inside
 graduado en el interior
 graduato all'interno



Ø x h

085-436-075 Ø 75 x 12 mm

Tablettenschale
 Tablet Tray
 Bandejita para tabletas
 Bacinella per compresse



085-450-090 Ø 90 x 90 mm

Mundbecher
 Metal cup
 Vaso metalico
 Bicchiere metallico



085-452-080 Ø 75 x 80 mm

Sputumbecher
 Sputum cup
 Escupidera
 Sputacciera



METHOD

085-464-075 Ø 50 x 75 mm

mit Deckel
 with lid
 con tapa
 con coperchio



METHOD

085-466-075 Ø 50 x 75 mm

ohne Deckel
 without lid
 sin tapa
 senza coperchio



METHOD

085-468-075 Ø 50 x 75 mm

ohne Deckel
 without lid
 sin tapa
 senza coperchio



Kunststoff
 plastic
 plastico
 materiale plastico

METHOD

085-470-055 Ø 45 x 55 mm

Einsatz
 Insert
 Inserto
 Inserto



085

Nierenschalen, Stechbecken
Kidney Dishes, Bed Pans
Riñoneras, Silletas
Bacinelle reniformi, Padelle



l x b x h

085-500-170	170 x 100 x 35 mm
085-500-250	250 x 140 x 40 mm
085-500-275	275 x 150 x 45 mm

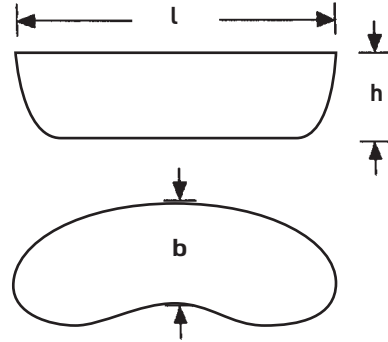

085-511-235 Ø 235 mm
085-511-310 Ø 310 mm

Knopfdeckel, allein
Lid knob, only
Tapa con boton, suelta
Coperchio a bottone, solo

085-510-235 Ø 235 mm
085-510-310 Ø 310 mm



085-520-600

innen graduert bis 600 ml, mit Griff
 graduated inside up to 600 ml, with handle
 graduado en el interior hasta 600 ml, con mango
 graduato all'interno fino a 600 ml, con manico



085-522-600

innen graduert bis 600 ml, ohne Griff
 graduated inside up to 600 ml, without handle
 graduado en el interior hasta 600 ml, sin mango
 graduato all'interno fino a 600 ml, senza manico



085-540-120 120 ccm



085-542-100 12 mm

Ersatzdocht, flach per Meter
 Spare Wick, flat, per meter
 Mecha de repuesto, plana, por metro
 Lucignolo di ricambio, piatto, per metro

085-544-012 12 mm

Ersatzdocht, flach, 12 cm lang
 Spare Wick, flat, 12 cm long
 Mecha de repuesto, plana, 12 cm de largo
 Lucignolo di ricambio, piatto, 12 cm di lunghezza



085

Wasserstrahl-Reinigungspistole
Water jet pistol
Pistola-lavatoria de chorro de agua
Pistola lavatrice a getto d`acqua



AQUAJET

085-600-000

komplett mit 9 Aufsätzen 085-602-001 bis 085-602-009,
1 m Druckschlauch, Haken und Schelle

complete, with 9 tips 085-602-001 to 085-602-009,
1 m pressure tube, strap and suspension hook

completa, con 9 toberas 085-602-001 a 085-602-009,
1 m tubo de presión, abrazadera y gancho de suspensión

completa, con 9 raccordi 085-602-001 fino a 085-602-009,
1 m tubo ad alta pressione, graffa e gancio di sospensione

Aufsätze siehe nächste Seite
tips see next page
toberas véase siguiente pagina
raccordi vedi seguente pagina

AQUAJET

085-601-000

ohne Aufsätze
without tips
sin toberas
senza raccordi



Fig. 1
085-602-001

für Flaschen
 for bottles
 para botellas
 per bottiglie



Fig. 2
085-602-002

für Record-Spritzen Konen
 for cones of record syringes
 para conos de jeringas Record
 per coni di siringhe Record



Fig. 3
085-602-003

für Katheter
 for catheters
 para catèteres
 per cateteri



Fig. 4
085-602-004

für Drainageschläuche
 for drainage tubings
 para tubos de drenaje
 per tubi di denaggio



Fig. 4
085-602-005

für Hohlgefäße
 for receptacles
 para recipientes
 per recipienti



Fig. 6
085-602-006

für Kanülen mit Record-Konus
 for hypodermic needles with
 Record-cone
 para agujas de inyección con
 cono Record
 per aghi ipodermici con cono
 record



Fig. 7
085-602-007

für Kanülen mit Luer-Konus
 for hypodermic needles
 with Luer cone
 para agujas de inyección con
 cono Luer
 par aghi ipodermici con
 con Luer



Fig. 8
085-602-008

für Meß- und Vollpipetten
 for measuring and volumetric
 pipettes
 para pipetas de medida y
 volumétricas
 per pipette comuni e
 graduate

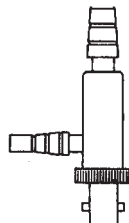

Fig. 9
085-602-009

für feine Pipetten
 for fine pipettes
 para pipetas finas
 per pipette fine



Fig. 10
085-604-310

Reinigungsaufsatz
 31 cm, gerade
 cleansing tip,
 31 cm, straight
 tobera de limpieza
 31 cm, recta
 per lavaggio, 31 cm
 retto



Fig. 11
085-605-310

Reinigungsaufsatz
 30 cm, abgebogen
 cleansing tip,
 30 cm, curved
 tobera de limpieza
 30 cm, curva
 per lavaggio, 30 cm
 curvo



085-610-034
 Überwurfmutter, 3/4 Zoll
 Coupling, 3/4 inch
 Tuerca-hembra, 3/4 pulgada
 Dado premistoppa, 3/4 pollici



085

Reinigungsbürsten
Cleaning Brushes
Cepillos de limpieza
Spazzole per pulire



a x b x c

085-700-003 245 x 65 x 3 mm



a x b x c

085-702-003 420 x 65 x 3 mm



a x b x c

085-704-008 270 x 65 x 8 mm

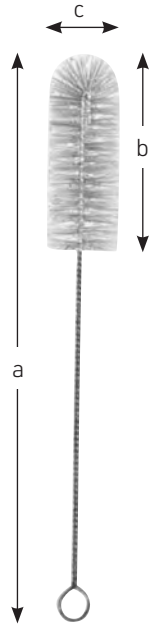

a x b x c

085-706-007 285 x 75 x 7 mm



a x b x c

085-710-012 270 x 65 x 12 mm



a x b x c

085-710-013 215 x 60 x 13 mm



a x b x c

085-710-015 215 x 70 x 15 mm



a x b x c

085-710-020 215 x 65 x 20 mm



a x b x c

085-710-025 215 x 65 x 25 mm



a x b x c

085-710-030 215 x 65 x 30 mm



085-720-000

Satz mit 5 Bürsten bestehend aus 085-710-013 -085-710-030
 Set of 5 brushes consisting of 085-710-013 -085-710-030
 juego de 5 cepillos compuesto de 085-710-013 -085-710-030
 set a 5 spazzole composto da 085-710-013 -085-710-030

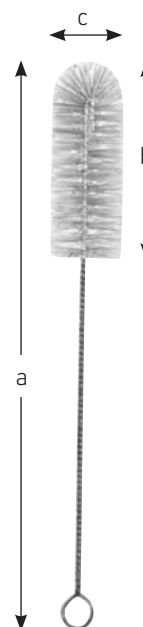



085

Reinigungsbürsten
Cleaning Brushes
Cepillos de limpieza
Spazzole per pulire



a x b x c

085-730-012 275 x 65 x 12 mm



a x b x c

085-730-015 275 x 80 x 15 mm



a x b x c

085-730-030 300 x 120 x 30 mm



a x b x c

085-730-050 320 x 130 x 50 mm



a x b x c

085-732-035 360 x 140 x 35 mm



a x b x c

085-734-040 420 x 180 x 40 mm

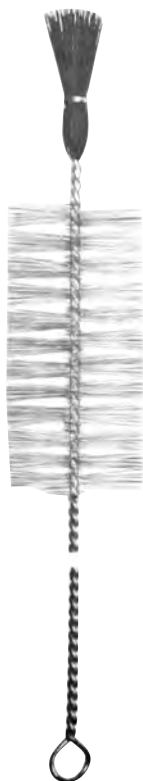

a x b x c
085-736-060 500 x 180 x 60 mm

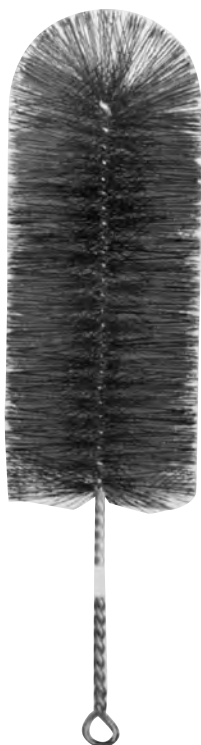

a x b x c
085-740-080 490 x 180 x 80 mm



a x b x c
085-741-060 450 x 180 x 60 mm



a x b x c
085-742-075 420 x 130 x 75 mm



a x b x c
085-746-050 330 x 130 x 50 mm



konisch
 conical
 cónico
 conico
 a x b x c
085-748-020 400 x 190 x 8/20 mm



085

Reinigungsbürsten
Cleaning Brushes
Cepillos de limpieza
Spazzole per pulire



konisch
conical
cónico
conico

a x b x c

085-750-033 300 x 110 x 18/33 mm



konisch
conical
cónico
conico

a x b x c

085-752-025 320 x 70 x 15/25 mm



konisch
conical
cónico
conico

a x b x c

085-754-015 420 x 60 x 8/15 mm



a x b x c

085-756-016 1000 x 180 x 16 mm



085-758-095 210 x 95 mm



085-800-325 Ø 325 mm

Inhalt 15l
capacity 15l
capacidad 15l
capacità 15l



085-802-325

Deckel
Lid
tapa
coperchi



085-810-580 58,0 cm / 22³/₄"



SAUERBRUCH

085-820-550 55,0 cm / 22"



FRIMED GMBH
Junkersstraße 1
78532 Tuttlingen
Germany

Telefon +49 74 61 9 66 18 30
Telefax +49 74 61 9 66 18 50
E-Mail info@frimed.de
Web www.frimed.com