

BAKER

RUSKINN

User Manual UM-047

CondoCell

**Intelligent Cell Culture System offering
Protection and Portability**



CondoCell System

Affix Serial Number Sticker Here



CONTENTS

- CONTENTS.....II
- TABLE OF FIGURES.....IV
- TABLES.....V
- INTRODUCTION..... 1
- SAFETY INSTRUCTIONS..... 2
- REGULATORY COMPLIANCE 3
 - EUROPEAN REGION..... 3
 - NORTH AMERICAN REGION..... 3
- PRECAUTIONS 4
- SYMBOLS..... 5
- TRANSPORT AND STORAGE..... 6
- LOCATION AND HANDLING OF THE CONDOCELL SYSTEM..... 6
 - LOCATION..... 6
 - ENVIRONMENTAL OPERATING CONDITIONS..... 6
- SERVICE REQUIREMENTS..... 7
 - ELECTRICAL SUPPLY REQUIREMENTS..... 7
 - GAS SUPPLY REQUIREMENTS 8
- CONDOCELL SYSTEM OVERVIEW 9
 - COMPONENT VIEWS 9
- SETTING UP THE CONDOCELL SYSTEM..... 13
 - INITIAL SETUP OF ACU..... 13**
 - Route Power Cable..... 13
 - Connect power supply..... 14
 - Route Tubing..... 15
 - Connect Tubing..... 15
 - Route Sensor Cable(s)..... 15
 - Plug in Door Sensor(s)..... 16
 - Mount Sensor Housing & Sensor..... 17
 - Mount Sensor Magnet..... 19
 - INITIAL SETUP OF CONDOCELL CHAMBER..... 22**
 - Fitting Filter..... 22
 - Fitting Seal..... 22
 - INITIAL SETUP OF PURGE UNIT..... 23**
 - Attach gas supply..... 23

Plug in power supply.....	23
Attach coupling lines.....	24
USING THE CONDOCELL SYSTEM	25
ACU OPERATION.....	25
Testing door sensor & ACU operation.....	25
Setting Timer.....	26
CONDOCELL CHAMBER OPERATION.....	27
Populating CondoCell.....	27
Fitting lid.....	28
Connecting gas supply coupling.....	29
Connecting exhaust coupling.....	30
Placing CondoCell Chamber into Incubation Equipment.....	30
Disconnecting couplings.....	31
Lid Removal.....	31
PURGE UNIT OPERATION.....	32
Setting required gas level.....	32
When using pre-mixed gas, the dial should be set to 0%.....	32
Connecting gas supply coupling.....	33
Purge operation.....	34
Purging multiple CondoCell Chambers.....	34
Repeating purge operation.....	34
CLEANING AND SERVICE REQUIREMENTS	35
SERVICE AND CLEANING OVERVIEW.....	35
CONDOCELL CLEANING PROCEDURE – AFTER EACH USE.....	36
CONDOCELL CLEANING PROCEDURE – DEEP CLEAN	36
ACU CLEANING PROCEDURE – AS REQUIRED	36
PURGE UNIT CLEANING PROCEDURE – AS REQUIRED	37
TROUBLESHOOTING	38
THE ACU WILL NOT SWITCH ON.....	38
THE PURGE UNIT WILL NOT SWITCH ON.....	38
THE SYSTEM IS ONLY PARTIALLY OPERATIONAL	38
WARRANTY INFORMATION	39
DISPOSAL INFORMATION	40
CONTACT DETAILS	41

TABLE OF FIGURES

Figure 1 - ACU connected to CondoCell Chamber..... 1

Figure 2 - ACU Connections..... 7

Figure 3 - Purge Unit Rear Connections 8

Figure 4 - CondoCell Chamber Top & Front..... 9

Figure 5 - CondoCell Chamber Underside & Rear 9

Figure 6 - CondoCell Chamber Identification Tag 10

Figure 7 – ACU Top View..... 11

Figure 8 - ACU Underside View..... 11

Figure 9 - Purge Unit (Optional Accessory) 12

Figure 10 - Purge Unit Rear View 12

Figure 11 - Drilling the Access Port Plug 13

Figure 12 - Power Cord Through Access Port Plug..... 13

Figure 13 - ACU Located in Incubator 14

Figure 14 - ACU Power Connection 14

Figure 15 - ACU Sensor Cable Connection 16

Figure 16 - Sensor Locations..... 17

Figure 17 - Cleaning Surface for Sensor Adhesion 17

Figure 18 - Sensor Adhesion..... 18

Figure 19 - Sensor in Place..... 18

Figure 20 - Marking Magnet Location..... 19

Figure 21 - Cleaning the Magnet Location 20

Figure 22 - Magnet in Location..... 20

Figure 23 - Checking Magnet Location..... 21

Figure 24 - Luer Fitting Syringe Filter 22

Figure 25 - Purge Unit Gas Connection 23

Figure 26 - Purge Unit Power Connection..... 23

Figure 27 - Connecting the Gas Couplings to the Purge Unit..... 24

Figure 28 - Couplings Stowed on Purge Unit..... 24

Figure 29 - Checking Sensor Alignment & Operation 25

Figure 30 - ACU Delay Timer..... 26

Figure 31 - Culture Vessel in CondoCell Chamber 27

Figure 32 - Fitting Lid to CondoCell Chamber 28

Figure 33 - Engaging Lid Latch 28

Figure 34 - Connecting the Gas Supply Coupling..... 29

Figure 35 - Connecting the Exhaust Coupling..... 30

Figure 36 - Coupling Disconnection..... 31

Figure 37 - Releasing the Lid Latch 31

Figure 38 - Setting Purge Value on Purge Unit..... 32

Figure 39 - Connecting Purge Unit to CondoCell Chamber..... 33

Figure 40 - Engaging Purge Operation..... 34



TABLES

Table 1 - List of Symbols..... 5
Table 2 - Electrical Service Requirements 7
Table 3 - Cleaning and Service Details 35
Table 4 - Troubleshooting 38

INTRODUCTION

Please read this manually carefully before use and familiarise yourself with all aspects of using the CondoCell system. The Baker Company and Ruskinn Technology Ltd do not accept any liability for accidents to personnel or damage to the CondoCell resulting from incorrect use.

The CondoCell system comprises of one or more CondoCell Culture Chambers and an Atmosphere Circulation Unit (ACU). An optional Purge Unit is also available, which allows the CondoCell Chamber gas concentration to be rapidly set to the correct oxygen level, prior to placement into incubation equipment.

The ACU circulates atmosphere from the location in which it is placed (Incubator, Workstation, Biological Safety Cabinet, lab bench, etc), through the CondoCell Chambers attached to it. If the ACU is placed within an incubator or workstation, then the gas concentrations, temperature and humidity of the atmosphere circulated to the CondoCell Chambers will match that within the incubator or workstation.

The many unique features of the CondoCell system are covered in detail in this manual. It is recommended that the user be fully conversant with the instruction and procedures, and that the operator familiarises themselves with all aspects and functions of the system before it is commissioned to maintain optimum performance.

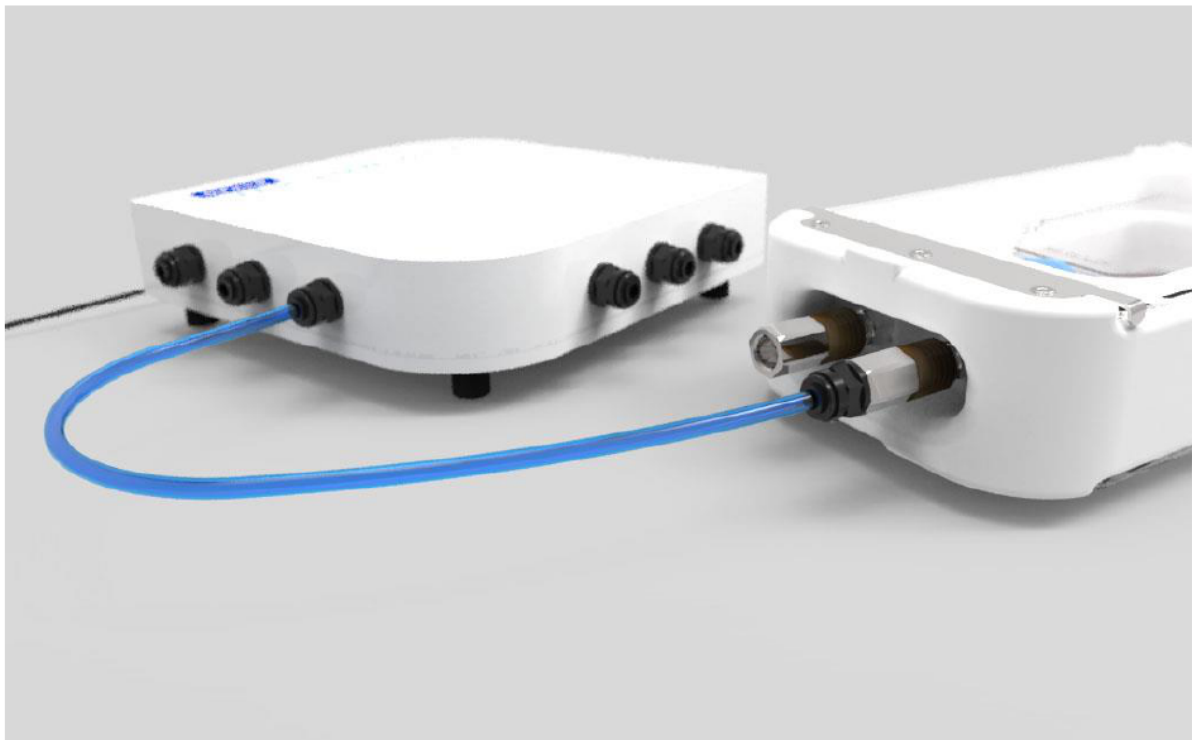

Figure 1 - ACU connected to CondoCell Chamber

SAFETY INSTRUCTIONS

Baker and/or Ruskinn do not take any responsibility for damages caused by using the equipment for other purposes than described in this installation manual.

- The mains appliance coupler and plug are the AC mains supply isolation device and must be easily accessible when installed.
- In case of emergency disconnect the CondoCell System components from the AC Mains Outlet.
- Ensure that the connecting cable is not squeezed or bent when the unit is being installed or moved.
- All servicing and repairs must be carried out by a qualified customer service engineer. Only genuine spare parts must be used.
- In case of damage to the CondoCell disconnect the System from the mains outlet and contact your local distributor.
- All covers and lids on the ACU and Purge Unit must only be removed by a qualified service engineer.
- Nothing should be placed on the top of the ACU.
- A power cord and switched 24V DC supply is supplied with both the ACU and Purge Unit and should be used to connect to the mains outlet. If a replacement is required it must be adequately rated for the application.
- All cables and pipes should be routed and secured to ensure that they do not pose a trip hazard.
- Mains supply Voltage fluctuation must not exceed $\pm 10\%$ of the nominal Voltage.
- Gas regulators must be used for gas supply to the Purge Unit. A 2 stage regulator is recommended. Over pressure could damage the CondoCell System. The Maximum permissible input pressure is 4 bar.
- Only the gases specified in this user manual may be used.
- All gas bottles must be adequately secured before connection to the Purge Unit.
- The end user is responsible for all materials and equipment places inside the Culture Chamber.
- The CondoCell system must not be operated at an ambient temperature over 40°C.
- The blower inlet on the underside of the ACU must not be covered or blocked.
- There should be no naked flames close to the CondoCell System.
- The use of radioactive materials is strictly prohibited.

CAUTION: Asphyxiation Risk

The Purge Unit uses Nitrogen (N₂) as part of normal use with the volume released externally in volumes deemed to be inconsequential. In the event of a leak or malfunction, this gas release may become excessive. DO NOT OPERATE this unit in a SMALL ENCLOSURE such as a small room or closed cabinet and ensure adequate ventilation is present. An accidental release of Nitrogen could create an asphyxiating atmosphere in a small space.

If the equipment is not use in a manner specified by the manufacturer, the protection provided by the equipment may be impaired.

Failure to adhere to these safety instructions could cause serious injury and will invalidate the CondoCell system warranty. Ruskinn Technology limited accepts no responsibility for any accident, injury or loss caused by unsafe operation of the CondoCell system.

REGULATORY COMPLIANCE

WEEE:



This equipment must be disposed of in accordance with the Waste from Electrical and Electronic Equipment (WEEE) Directive

This product must not be treated as household waste. Instead, it shall be handed over to an appropriate collection point for the recycling of electrical and electronic equipment.

If in doubt, please return this equipment to Ruskinn Technology Ltd who will correctly dispose of it for you. We strongly recommend that this product is returned to RTL at the end of its useful life.

European Region



This product complies with the essential EEA requirements for Electrical Safety and Electromagnetic compatibility as set out in the EMC Directive 2014/30/EU, the Low Voltage Directive 2014/35/EU and hazardous substances (RoHS) Directive 2011/65/EU has been tested and found to comply in full.

For details on standards used for assessment refer to the DoC Certificate.

North American Region

This equipment has been tested and found to comply with the limits for a Class A digital device, pursuant to part 15 of the FCC Rules. These limits are designed to provide reasonable protection against harmful interference when the equipment is operated in a commercial environment. This equipment generates, uses, and can radiate radio frequency energy and, if not installed and used in accordance with the instruction manual, may cause harmful interference to radio communications. Operation of this equipment in a residential area is likely to cause harmful interference in which case the user will be required to correct the interference at his own expense.

Precautions

The ACU and Purge Unit have been assessed against EN61010-1. This means that the both pieces of equipment meet or exceed the requirements for general electrical laboratory equipment in terms of their levels of emitted electromagnetic (EM) radiation and their susceptibility to electromagnetic radiation from other devices. It should be noted that the ACU and Purge Unit may be affected by high levels of stray EM radiation from other electronic devices (even those which comply with relevant CISPR emission standards) that are being used in close proximity to them.

WARNING: This system may cause radio interference or may disrupt the operation of nearby equipment. It may be necessary to take mitigation measures, such as re-orienting or relocating the equipment or shielding the location.

Symbols

Before using the CondoCell system, please ensure that you are familiar with the symbols.









Symbol	Meaning
	Refer to user manual.
~	Alternating current
O	Off
I	On
	Functional Earth Connection
	Protective Earth/Ground Connection
	Caution, do not remove covers. No end user serviceable parts behind covers. Please refer to this manual in all cases where this symbol appears, in order to find out the nature of the Potential Hazard and actions to be taken in order to avoid the Hazard.
	Warning, this equipment contains high voltage circuitry.
	Contains material or substances that may be hazardous to human health. Please refer to your local biohazardous material handling procedure for further advice on the handling and disposal of these items.
	The CondoCell system contains hazardous components and must not be disposed of at a household waste site. Instead it should be taken to the appropriate collection point for the recycling of electrical and electronic equipment.
	USB socket
	Date of manufacture in format YYYY MM

Table 1 - List of Symbols

TRANSPORT AND STORAGE

When not in use, the CondoCell system must only be stored under the following environmental conditions:

- Temperature – Between 0°C and 30°C
- Humidity – 90% RH maximum, Non-Condensing

Storage outside of this range may damage the CondoCell System.

LOCATION AND HANDLING OF THE CONDOCELL SYSTEM

Location

Ruskinn Technology Ltd recommends the components of the CondoCell system be situated on a suitably constructed level surface that is clear of all obstructions.

In particular, it is important to ensure that the system components are kept out of direct sunlight.

Environmental Operating Conditions

The CondoCell System Purge Unit should only be operated under the following environmental conditions:

- Temperature – Between 15°C and 30°C
- Humidity – Between ambient and 90% RH, Non-Condensing

The CondoCell System ACU and CondoCell Chamber should only be operated under the following environmental conditions:

- Temperature – Between 15°C and 40°C
- Humidity – Between ambient and 95% RH, Non-Condensing

SERVICE REQUIREMENTS

Electrical Supply Requirements

The ACU and Purge Unit must be connected to a 24V DC power supply. AC/DC switching adaptors and mains power cords are supplied to connect the ACU and Purge Unit to the mains supply.

To ensure safe operation of the ACU and Purge Unit, they must be connected to a supply of the correct voltage as stated on the rating label shown at the rear of the unit. The mains supply voltage fluctuations must not exceed +/- 10% of the nominal mains voltage. The input voltage and frequency for ACU and Purge Unit are:

Input Voltage	Frequency	Rated Current	Power
100 to 240 Vac	50/60Hz	1.4A	
Output Voltage			
24 VDC	-	2.5A	60W max.

Table 2 - Electrical Service Requirements

Please note that the applicable ratings for the ACU and Purge Unit are detailed on the labelling attached to the parts as shown in Figure 2 and Figure 3.

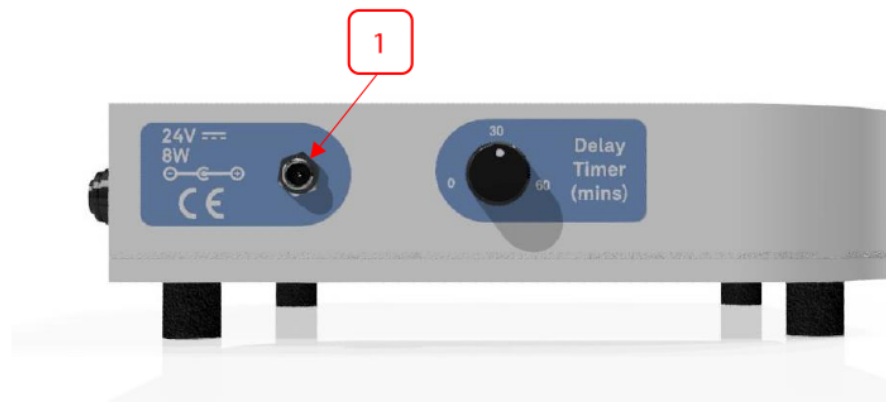

Figure 2 - ACU Connections

1. CondoCell Electrical Connector



Figure 3 - Purge Unit Rear Connections

1. Purge Unit Electrical Connector
2. Purge Unit Gas Connector

Gas Supply Requirements

The recommended gas supply is 100% N₂ (industrial or medical grade is acceptable)

Pre-mixed gases of N₂, CO₂ & O₂ if the O₂ level is 25% or less.

In some instances, it may be preferable to use an alternative gas as the purge medium, such as Argon. Please contact Ruskin or our distribution partners to discuss this.

CONDOCELL SYSTEM OVERVIEW

The CondoCell, ACU and Purge Unit are shown below in the following figures.

Component Views

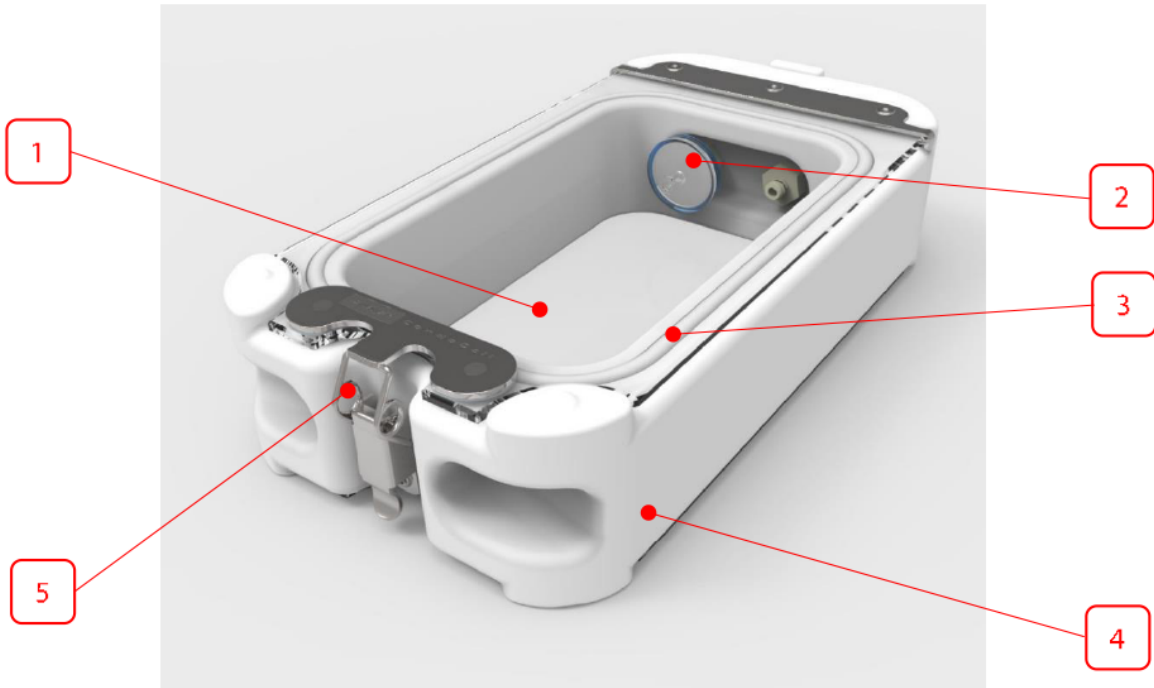

Figure 4 - CondoCell Chamber Top & Front

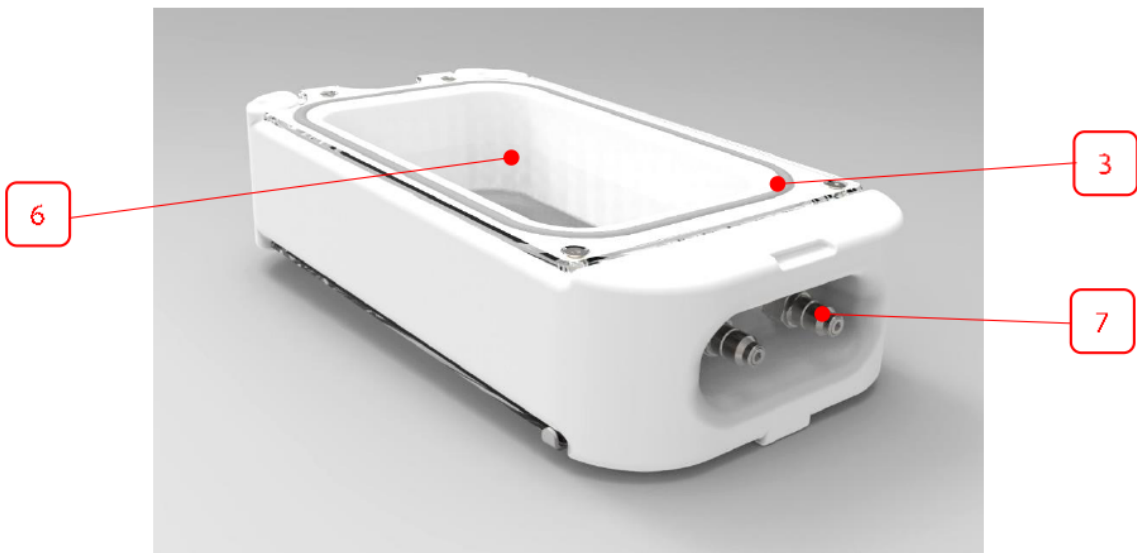

Figure 5 - CondoCell Chamber Underside & Rear

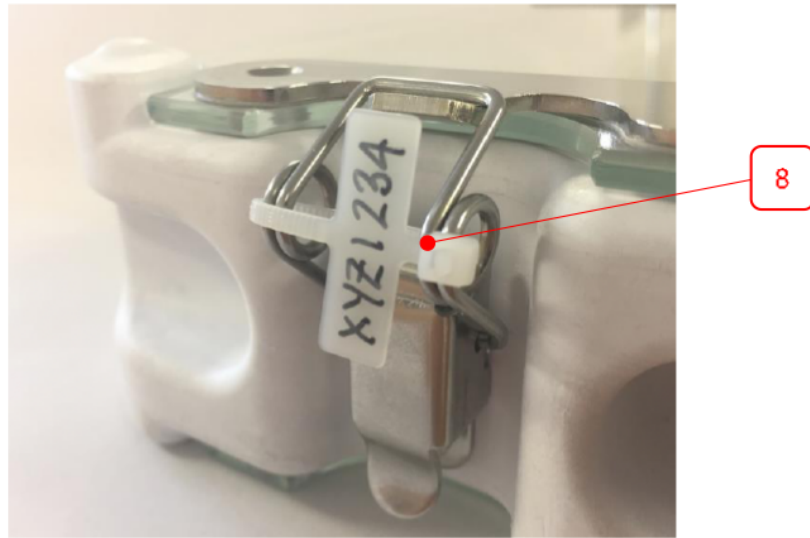

Figure 6 - CondoCell Chamber Identification Tag

1. Glass Lid
2. Filter (fitted only to gas inlet not to exhaust)
3. Gasket
4. CondoCell Chamber Body
5. Lid Latch
6. Glass Base
7. Inlet and Exhaust Couplings
8. CondoCell Chamber Identification Tag – Accessory available from Baker Ruskin or our distribution partners



Figure 7 – ACU Top View

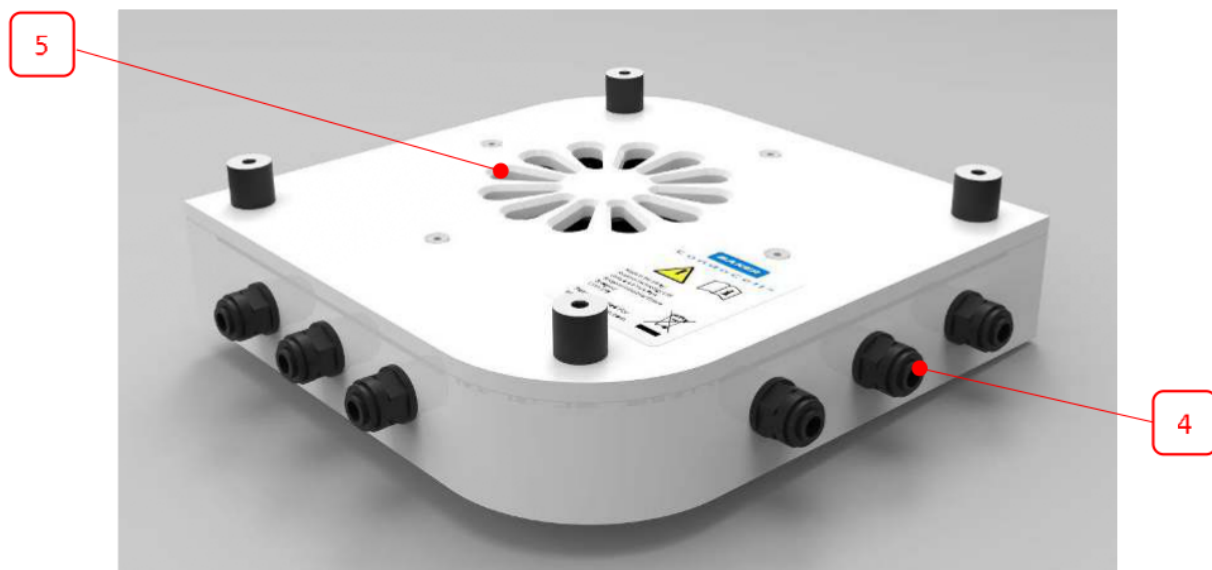

Figure 8 - ACU Underside View

1. 24V DC Power Connector
2. Timer Delay Setting Dial
3. Door Sensor Connection Points (1 to 4)
4. Circulation Tubing Fittings
5. Blower Inlet

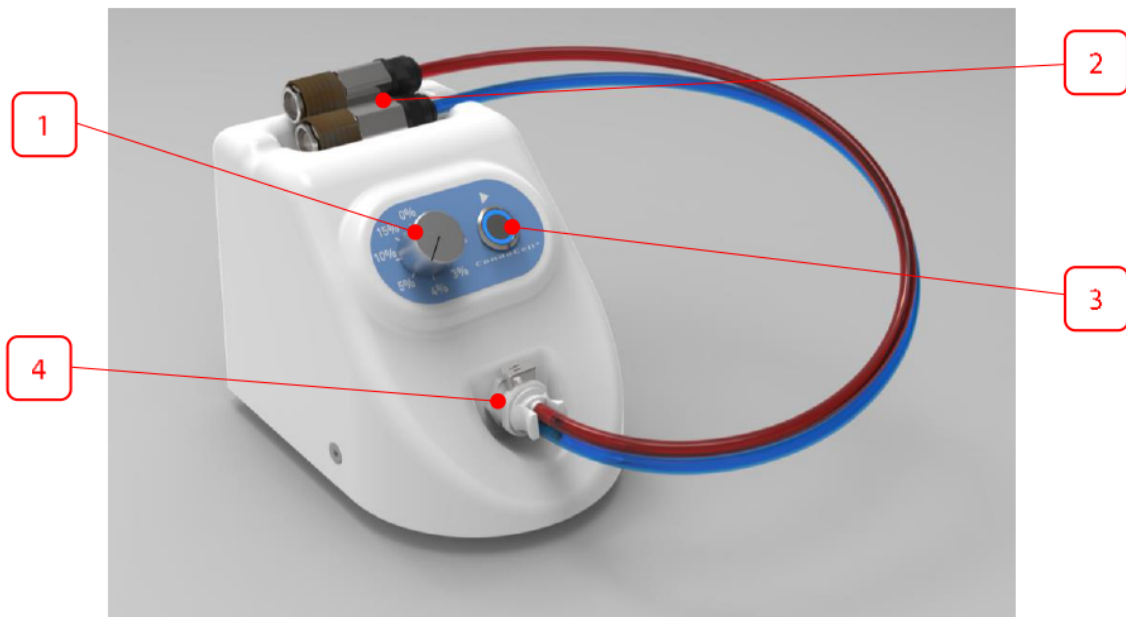

Figure 9 - Purge Unit (Optional Accessory)

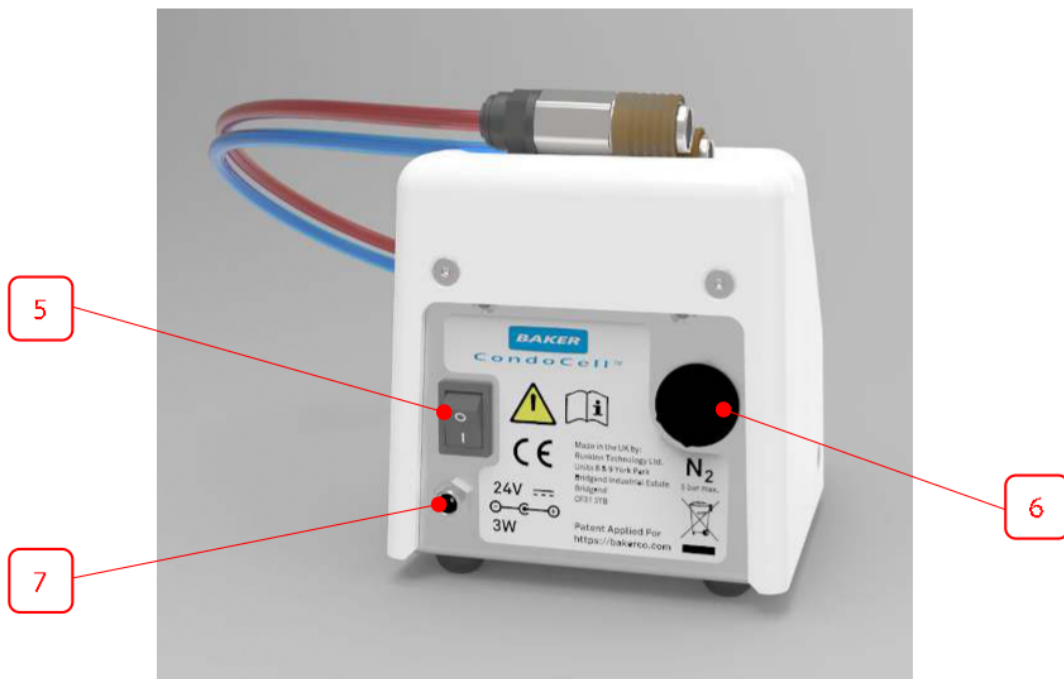

Figure 10 - Purge Unit Rear View

1. Percentage Oxygen Setting Dial
2. Purge and Exhaust Connectors (shown resting in storage location)
3. Start Button
4. Purge & Exhaust Line Coupling
5. On/Off Switch
6. Gas Connector
7. 24V DC Power Connector

SETTING UP THE CONDOCELL SYSTEM

Initial Setup of ACU.

Route Power Cable.

Locate access port on incubator.

Drill a Ø3mm hole through the access port plug.

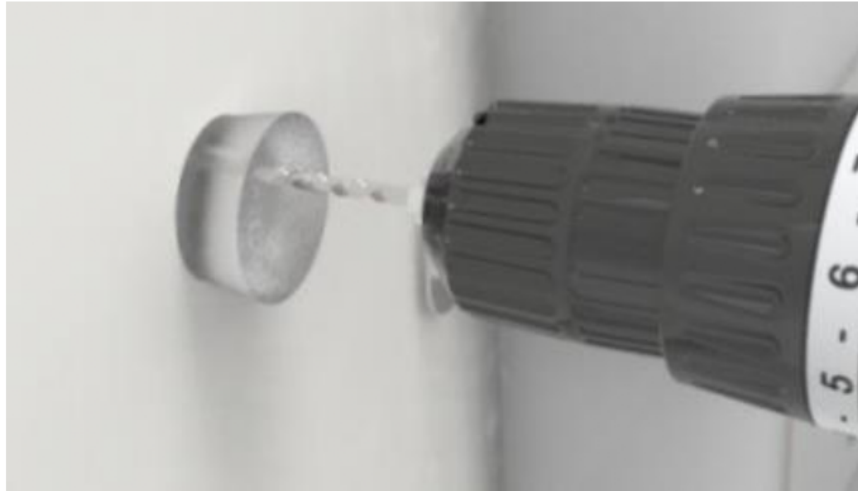

Figure 11 - Drilling the Access Port Plug

Create a slit from the edge of the plug to the hole to allow the power cable to be fitted through the plug.

Pass the power cord connector through the access port and replace the access port plug – a small amount of silicone sealant may need to be used to ensure a gas tight seal.



Figure 12 - Power Cord Through Access Port Plug

Identify location for ACU, ensuring it will be within reach of the power cable routed from the access port. Care should be taken to minimise the risk of spillages within the incubation equipment from landing on the ACU.

Inside the incubator, route the power cable from the access port to the shelf the ACU is to be located.

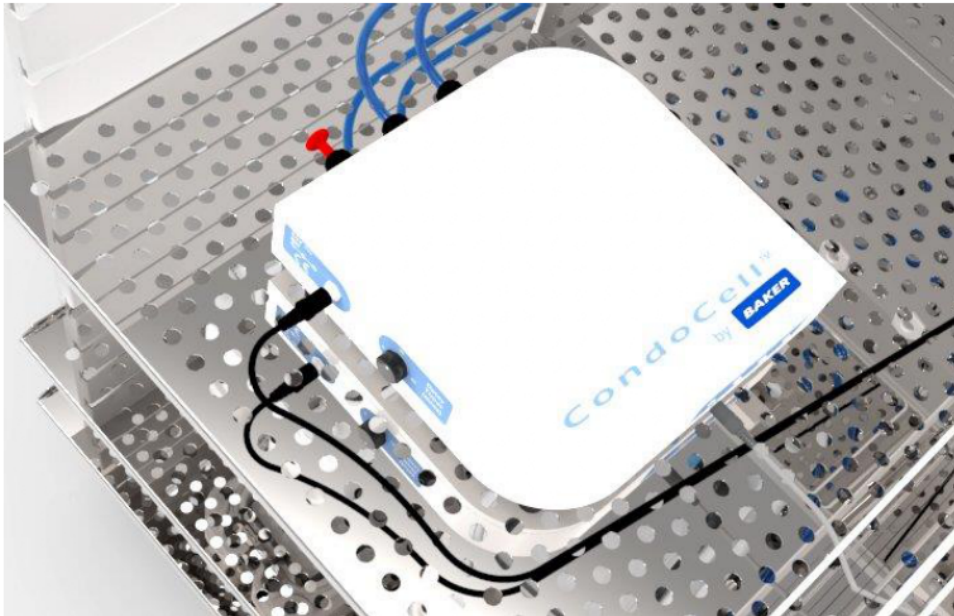

Figure 13 - ACU Located in Incubator

Where possible route power cable to avoid other items in the incubator.

Care should be taken to avoid or shield the power cable from metal edges which may cause damage.

Connect power supply.

Push the connector firmly into the socket.



Figure 14 - ACU Power Connection

Route Tubing.

Starting from the shelf/shelves the CondoCells are to be located, route the tubing to the shelf where the ACU is to be located.

Care should be taken to avoid or shield the tubing from metal edges which may cause damage.

Where possible route tubing to avoid other items in the incubator.

Connect Tubing.

Push the tubing end firmly into a black tube fitting on the ACU. Any free tube fitting can be used.

For any black tube fittings not populated with tubing, plug the fitting with a red plug.



Route Sensor Cable(s)

Inside the incubator, route the sensor cable from the access port to the shelf the ACU is to be located.

Where possible route sensor cable to avoid other items in the incubator.

Care should be taken to avoid or shield the sensor cable from metal edges which may cause damage.

Plug in Door Sensor(s).

For single sensor, place sensor plug in socket marked "1".



Figure 15 - ACU Sensor Cable Connection

For additional sensors, populate the sensor sockets in numerical order.

Mount Sensor Housing & Sensor.

Select appropriate door sensor location(s) – Housing can be mounted horizontally or vertically.



Figure 16 - Sensor Locations

Clean mounting point with supplied alcohol wipe – wait for the alcohol to air dry.



Figure 17 - Cleaning Surface for Sensor Adhesion

Peel off adhesive backing tape from base of Sensor Mount & position Sensor – Adhesive is pressure sensitive: press lightly initially, check location, reposition if necessary. When correct, press housing base firmly against mounting point to activate pressure sensitive adhesive.



Figure 18 - Sensor Adhesion

Sensor tip should be within 10mm of the inner door when inner door is closed.



Figure 19 - Sensor in Place

Mount Sensor Magnet.

Mark sensor location on closed inner door glass using a pen.



Figure 20 - Marking Magnet Location

In some cases it may not be possible to locate the sensor adjacent to glass of the inner door, in which case an alternate method should be used to indicate where the sensor is aligning to e.g. a piece of adhesive putty (e.g. blutack) or similar placed on the inner door.

Note – The Sensor Housing has integrated cable-tie/zip-tie features to provide an alternate mounting method.

When location is established, clean the area for bonding the magnet with alcohol wipe and wait for alcohol to air dry.



Figure 21 - Cleaning the Magnet Location

Peel off the backing material for the self-adhesive on the magnet and press the magnet firmly into position. Location mark can then be cleaned away with an alcohol wipe.



Figure 22 - Magnet in Location

Close the door and check the magnet aligns well with the sensor tip. To verify good magnet alignment refer to "Using the CondoCell System" on page 24.



Figure 23 - Checking Magnet Location

Initial Setup of CondoCell Chamber.

Fitting Filter.

The 0.2µm filter has a standard luer fitting with a twist lock.

Push the filter onto the female luer fitting attached to the inlet inside the CondoCell, twist clockwise to tighten the filter onto the luer fitting.



Figure 24 - Luer Fitting Syringe Filter

Only approved filters should be used to ensure atmosphere circulation is not compromised in the CondoCell Chamber.

Replacement filters are available from Baker Ruskinn or our distribution partners. (Baker Ruskinn part number: 260-1930).

Care must be taken to attach the filter only to the inlet fitting and not to the exhaust fitting, fitting a filter to the exhaust fitting will compromise system performance and may result in loss of cultures.

Fitting Seal.

The seal is a cord of silicone foam, which presses easily into the slot in the top and bottom surfaces of the CondoCell Housing.

The Gasket will show a flattened section when the pressure of the Lid is removed, this is normal and will not compromise the function of the seal.

The seal is not bonded to the CondoCell Housing, and may come away from its seating feature when the Lid or Base are removed. The Gasket can be easily pushed back into position and seal function will not be compromised.

It is recommended that the Gasket is replaced if it shows signs of damage.

Replacement Gaskets are available from Baker Ruskinn or our distribution partners. (Baker Ruskinn part number: 263-593).

Initial Setup of Purge Unit.

Attach gas supply.

Attach 6mm Nitrogen supply tubing to Purge Unit by pushing firmly into the fitting labelled N₂ on the rear.



Figure 25 - Purge Unit Gas Connection

Note: In some instances, it may be preferable to use an alternative gas as the purge medium, such as Argon. Please contact Baker Ruskin or our distribution partners to discuss this.

Plug in power supply.

Push the 24V DC switched power supply connector firmly into the socket on the rear of the Purge Unit.



Figure 26 - Purge Unit Power Connection

Attach coupling lines.

The two gas couplings are attached via tubing to a two way coupling. The coupling clips into the corresponding fitting on the Purge Unit.



Figure 27 - Connecting the Gas Couplings to the Purge Unit

The Coupling can be stowed on top of the Purge Unit housing when not in use.



Figure 28 - Couplings Stowed on Purge Unit

Refer to page 32 for information on operation of the Purge Unit.

USING THE CONDOCELL SYSTEM

ACU Operation.

Testing door sensor & ACU operation.

Switch on the power supply to the ACU.

Set timer dial to 0, this sets the delay to approximately 10 seconds.

Close door to allow magnet to activate the door sensor (door sensor LED should light up red).



Figure 29 - Checking Sensor Alignment & Operation

Wait 10 seconds – ACU fan should start to operate.

Setting Timer.

Refer to Incubator manufacturer's documentation to establish typical recovery time; the time taken to stabilise incubator atmosphere after door closure. This is typically 20-30 minutes for most Incubators.

Timer setting dial is marked with 0, 30 and 60 minutes, use these as a rough guide to select an appropriate time to delay the reactivation of the ACU following door closure.



Figure 30 - ACU Delay Timer

The ACU will delay recommencement of the circulation of atmosphere until the set time elapses.

Note – great care should be taken when moving objects near to the ACU, to ensure the timer setting dial is not moved inadvertently.

CondoCell Chamber Operation.

Populating CondoCell.

Place culture vessel inside the CondoCell, ensuring that the filter on the inlet and exhaust fitting are not blocked by the vessel.



Figure 31 - Culture Vessel in CondoCell Chamber

Fitting lid.

With the seal in place, slot the lid glass under the bracket attached to the rear end of the CondoCell.

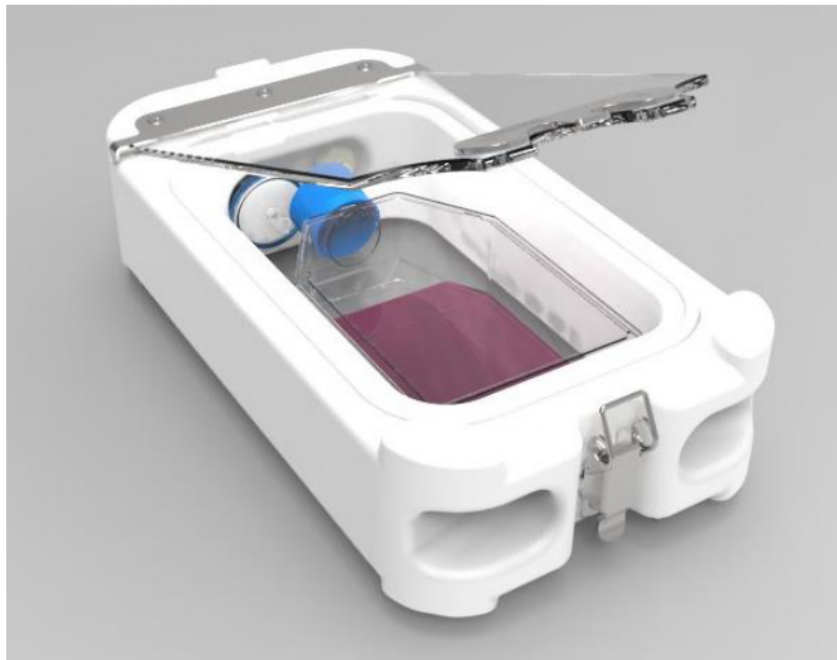

Figure 32 - Fitting Lid to CondoCell Chamber

Push the latch on the Lid down to compress the seal under the glass of the Lid.

Engage the latch on the bracket attached to the lid and push the latch lever downwards and inward until the latch locks in place.

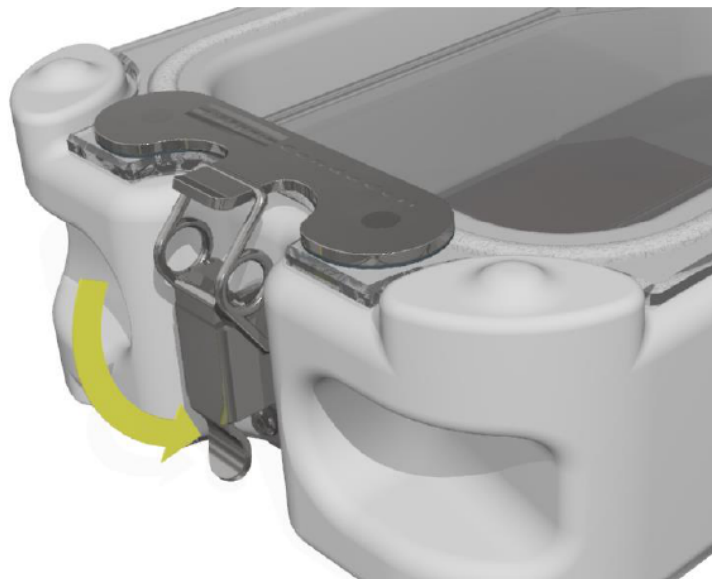

Figure 33 - Engaging Lid Latch

Connecting gas supply coupling.

Push the female gas supply coupling fitted to the end of the ACU gas supply tube onto the corresponding male coupling attached to the CondoCell on the side that is in line with the internal filter. This is the Intake coupling.

When the darker coloured collar on the coupling clicks forward, the coupling is locked in place.



Figure 34 - Connecting the Gas Supply Coupling

Note – Objects should not be pushed into the open ends of the male or female couplings, as damage may occur.

Connecting exhaust coupling.

Push the female exhaust coupling onto the corresponding male coupling attached to the CondoCell in line with the unfiltered exhaust outlet.

When the darker coloured collar on the coupling clicks forward, the coupling is locked in place.



Figure 35 - Connecting the Exhaust Coupling

Placing CondoCell Chamber into Incubation Equipment.

When transporting the CondoCell Chamber to the incubation space, care should be taken to ensure minimal disruption to the culture vessel contents. It is recommended that placement of culture vessels into the CondoCell Chamber be carried out in close proximity to the incubation equipment.

Care should be taken when placing the CondoCell Chamber within the incubation equipment, do not slide the Chamber over hard surfaces. The glass Base of the CondoCell Chamber is designed to be in contact with the surface the Chamber is placed upon in order to maximise microscopy effectiveness.

Disconnecting couplings.

To disconnect the couplings, pull backward on the darker coloured collar on the female coupling and the couplings will disengage from the male coupling.

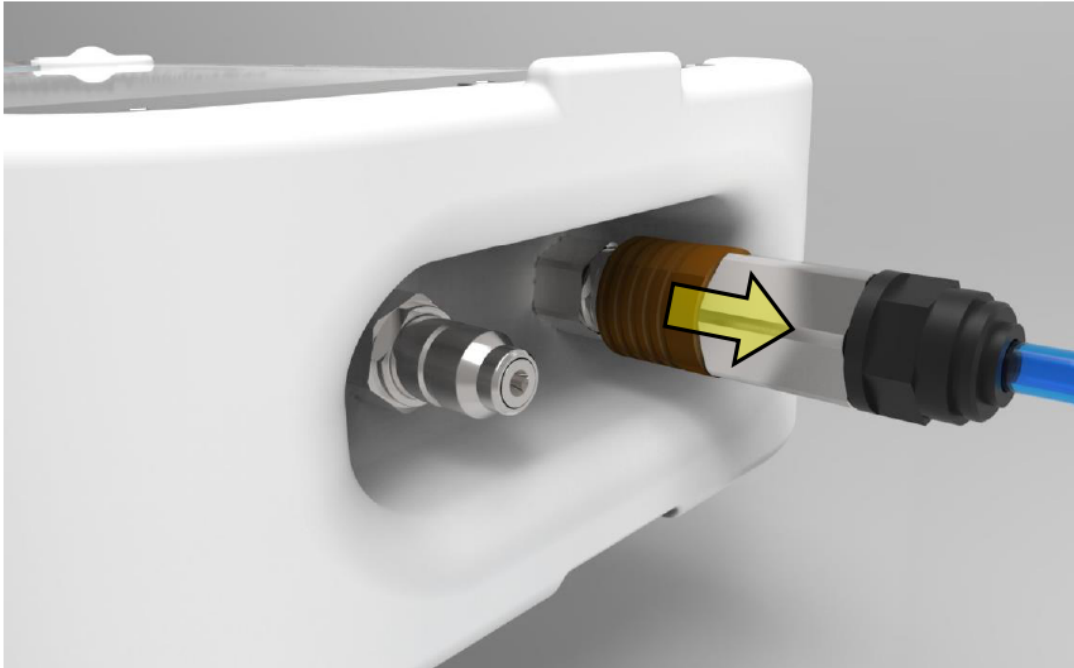

Figure 36 - Coupling Disconnection

Lid Removal.

To release the lid, pull outwards on the latch lever until the latch releases from the lid bracket.

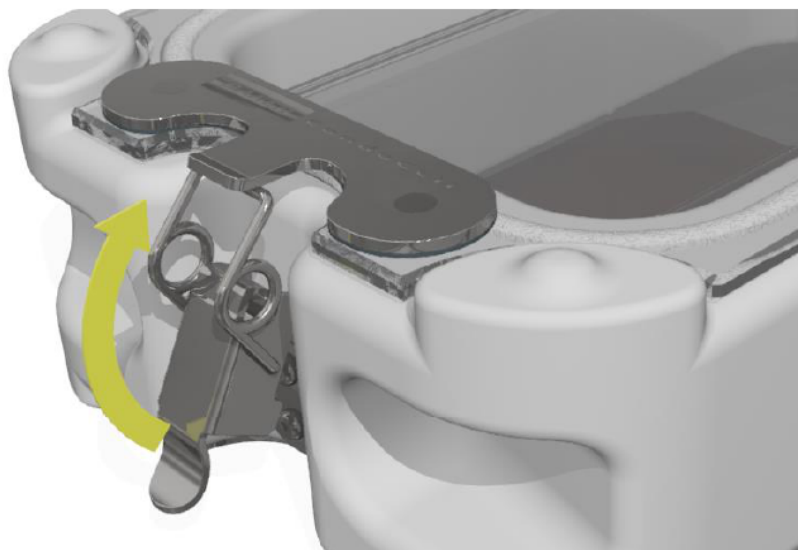

Figure 37 - Releasing the Lid Latch

Purge Unit Operation.

Setting required gas level.

Rotate the dial to the required percentage O₂ required in the CondoCell Chamber. This sets a pre-calibrated timer to meter the volume of N₂ into the CondoCell Chamber.



Figure 38 - Setting Purge Value on Purge Unit

When using pre-mixed gas, the dial should be set to 0%.

Connecting gas supply coupling.

Push the female gas supply coupling fitted to the blue tube onto the corresponding male coupling attached to the CondoCell in line with the filter.

When the darker coloured collar on the coupling clicks forward, the coupling is locked in place.

Connecting exhaust coupling.

Push the female exhaust coupling fitted to the red tube onto the corresponding male coupling attached to the CondoCell in line with the unfiltered exhaust outlet.

When the darker coloured collar on the coupling clicks forward, the coupling is locked in place.

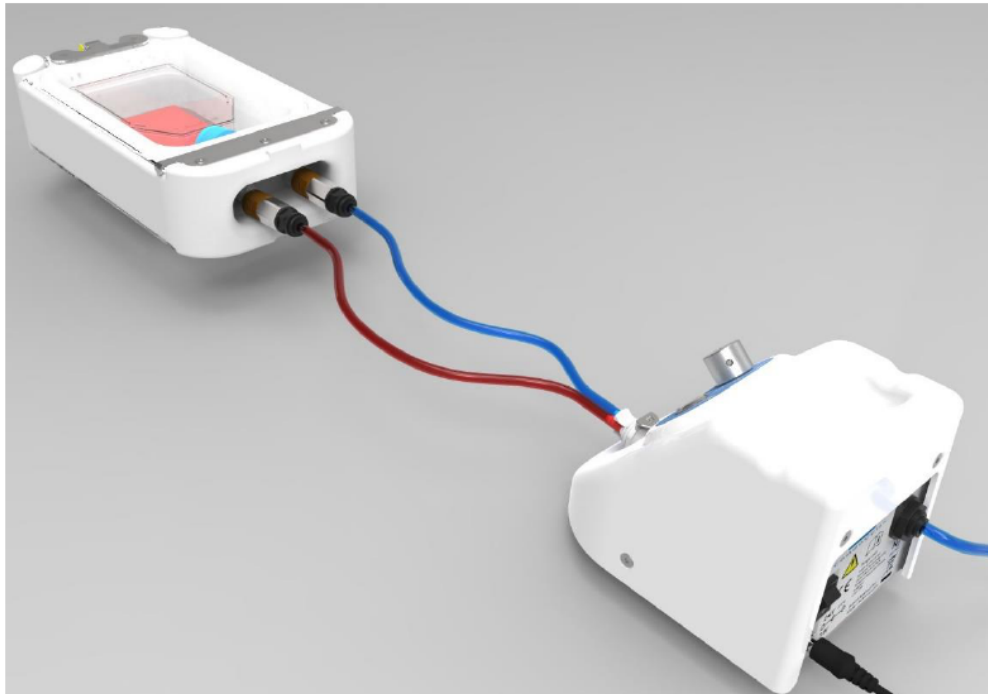

Figure 39 - Connecting Purge Unit to CondoCell Chamber

Purge operation.

Press the activate button to start the purging operation, the blue button halo illumination will flash during the gas input phase.



Figure 40 - Engaging Purge Operation

Once the purge operation has finished, the blue button halo will illuminate solidly to indicate that the gas level is set within the CondoCell Chamber.

Purging multiple CondoCell Chambers.

To carry out a purge on the next CondoCell Chamber, attach the next Chamber and press the button to commence the purge operation.

Repeating purge operation.

If the CondoCell Chamber is left attached to the Purge Unit, the button halo will eventually extinguish, this indicates that the purge operation should be repeated, as the gas level in the CondoCell Chamber may have decayed.

In this case, to repeat the purge, open the CondoCell Chamber to bring the Chamber volume back to ambient gas concentrations, reseal the CondoCell Chamber, and reactivate the purge operation.

CLEANING AND SERVICE REQUIREMENTS

Service and Cleaning Overview.

To maintain optimal performance of the chamber it must be serviced at regular intervals. Lists of the servicing requirements, intervals and persons capable of performing the recommended service are detailed in Table 3.

Action	Frequency	By
Clean CondoCell Chamber	After each use	End User
Deep Clean CondoCell Chamber	As required	End User
Clean ACU	As required	End User
Clean Purge Unit	As required	End User
Bi-Annual Service	Every second year	Service Engineer

Table 3 - Cleaning and Service Details

The correct cleaning agents must be used to clean the chamber. The use of incorrect cleaning agents will damage the chamber and invalidate the warranty. The following cleaning agents are permitted:

- Ethanol, laboratory grade at a maximum concentration of 70% by volume ethanol in distilled water.
- Isopropanol, laboratory grade at a maximum concentration of 70% by volume Isopropanol in distilled water.
- Tristel Fuse Sachet, 1 sachet diluted in 3 litres of distilled water, or Tristel Duo Foamer. Tristel Fuse Sachets and Duo Foamer are available from Baker Ruskinn.
- Baker Ruskinn anti-static cleaner.
- Distilled or de-ionised water.

No other cleaning agents are permitted.

The use of UV light is prohibited on any of the CondoCell System components, as it will cause permanent damage. The use of UV Light on the CondoCell System components will invalidate the warranty.

The use of an autoclave is not recommended on any of the CondoCell System components. During use, clean any spills immediately using paper towels soaked in an appropriate cleaning agent. Wipe dry using a dry paper towel.

CondoCell Cleaning Procedure – After Each Use

- Remove Lid.
- Remove all waste materials from the CondoCell Chamber.
- If required, remove used filter.
- Wipe the CondoCell Chamber interior using paper towels soaked an appropriate cleaning agent and squeezed to remove excess fluid.
- Wipe the CondoCell Chamber interior clean using paper towels to dry.
- If required, fit new filter to inlet fitting.

CondoCell cleaning procedure – Deep Clean

- Remove Lid.
- Remove all waste materials from the CondoCell Chamber.
- Remove used filter.
- Remove Base using appropriate tool to loosen four fixing screws.
- Remove gaskets and check for damage, replace gaskets if necessary.
- Wipe the CondoCell Chamber components using paper towels soaked an appropriate cleaning agent and squeezed to remove excess fluid.
- Wipe the CondoCell Chamber components with paper towels to dry.
- Reinstall the Base by gradually tightening the fixing screws with an appropriate tool, ensuring to tighten the fixings a little at a time, cycle between each fixing to tighten them at a similar rate to avoid over stressing the glass, until the Base is fixed in place. The screws for the base are secured with a captive washer. During re-securing the screws, stop tightening once this washer contacts the chamber housing, this should provide adequate gasket compression without over-stressing the glass base.

NOTE – The Base and Lid glass are toughened glass. In the event of failure, this type of glass shatters into small pieces which are less likely to cause injury.

- Fit new filter to inlet fitting.

ACU Cleaning Procedure – As Required

- Wipe the ACU outer surfaces using paper towels soaked an appropriate cleaning agent and squeezed to remove excess fluid.
- Wipe the ACU components with paper towels to dry.

Note – the internal components of the ACU should only be cleaned and serviced by trained service personnel.

Purge Unit Cleaning Procedure – As Required

- Wipe the Purge Unit outer surfaces using paper towels soaked an appropriate cleaning agent and squeezed to remove excess fluid.
- Wipe the Purge Unit with paper towels to dry.

NOTE – the internal components of the ACU should only be cleaned and serviced by trained service personnel.

TROUBLESHOOTING

Problem	Cause	Solution
The ACU will not switch on	<p>The ACU is not plugged in</p> <p>The mains socket is not switched on</p> <p>The mains fuse has blown</p> <p>The door sensor fails to trigger ACU to operate</p>	<p>Plug the Switched Adaptor into the ACU.</p> <p>Switch the mains power on.</p> <p>Replace the mains fuses.</p> <p>Check that the door sensor(s) are aligned with magnets. (Red light illuminates on sensor when active.)</p>
The Purge Unit will not switch on	<p>The Purge Unit is not plugged in</p> <p>The mains socket is not switched on</p> <p>The mains fuse has blown</p>	<p>Plug the Switched Adaptor into the Purge Unit.</p> <p>Switch the mains power on.</p> <p>Replace the mains fuses.</p>
The System is only partially operational	Various	If some features of the system are not working correctly then please contact your local distributor to arrange a service engineer visit

Table 4 - Troubleshooting

WARRANTY INFORMATION

Ruskinn Technology Limited warrants for the applicable time period that the CondoCell Chamber, ACU and Purge Unit (the CondoCell System) will substantially perform in accordance with the user documentation. The terms of this Agreement do not affect or prejudice the statutory rights of a consumer acquiring the Ruskinn Technology Limited CondoCell otherwise than in the normal course of a business.

THIS WARRANTY DOES NOT APPLY IN THE FOLLOWING CIRCUMSTANCES:

(A) IF THE Ruskinn Technology Limited CondoCell System HAS BEEN REPAIRED BY PERSONS NOT AUTHORIZED BY Ruskinn Technology Limited; OR

(B) THE Ruskinn Technology Limited CondoCell System and associated accessories/peripherals HAVE BEEN ALTERED, MODIFIED, OR MISUSED; OR

(C) THE Ruskinn Technology Limited CondoCell System IS USED WITH NON- Ruskinn Technology Limited COMPONENTS; OR

(D) THE Ruskinn Technology Limited CondoCell System OR A COMPONENT IS USED FOR OTHER USES (FOR EXAMPLE USE WITH OTHER CIRCUIT BOARDS OR SOFTWARE) OR

(E) THE Ruskinn Technology Limited CondoCell System HAS NOT BEEN MAINTAINED OR USED IN ACCORDANCE WITH THE INSTALLATION AND USER GUIDE. UNLESS PROHIBITED BY LAW, THIS WARRANTY IS MADE IN LIEU OF ALL OTHER WARRANTIES, EXPRESS OR IMPLIED, INCLUDING BUT NOT LIMITED TO THE IMPLIED WARRANTY OF FITNESS FOR A PARTICULAR PURPOSE, THE IMPLIED WARRANTY OF MERCHANTABILITY, OR ANY IMPLIED WARRANTY ARISING OUT OF A COURSE OF DEALING OR OF PERFORMANCE, CUSTOM OR USAGE OF TRADE. Ruskinn Technology Limited DOES NOT WARRANT THAT THE Ruskinn Technology Limited CondoCell System WILL FUNCTION ERROR FREE.

If within the Warranty Period, the Ruskinn Technology Limited CondoCell System does not conform to the express warranty set forth above, Ruskinn Technology Limited's sole obligation and Users sole remedy shall be, at Ruskinn Technology Limited's option: 1. to repair or replace the non-conforming component; or, 2. refund the purchase price.

LIMITATION OF LIABILITY.

UNLESS PROHIBITED BY LAW, Ruskinn Technology Limited WILL NOT BE LIABLE TO USER OR OTHERS FOR ANY OTHER DIRECT, INDIRECT, CONSEQUENTIAL, INCIDENTAL OR SPECIAL DAMAGES INCLUDING,

FOR EXAMPLE, LOST PROFITS, BUSINESS, INVESTMENTS, OR OPPORTUNITIES EVEN IF Ruskinn Technology Limited HAS BEEN ADVISED OF THE POSSIBILITY OF SUCH DAMAGES.

The parties agree that Ruskinn Technology Limited total cumulative liability to User for direct damages for all causes under this Agreement shall not exceed £5,000,000 (FIVE MILLION UK STERLING POUNDS), or the price paid for the Ruskinn Technology Limited CondoCell whichever is higher. Some states or countries may have laws which require liability rights different from those stated above. In such states or countries, the minimum required liability terms shall apply

DISPOSAL INFORMATION

The CondoCell System contains hazardous components and must not be disposed of at a household waste site. Instead it should be taken to the appropriate collection point for the recycling of electrical and electronic equipment. Alternatively, please contact your local distributor for disposal instructions.

The CondoCell System contains recyclable parts. Please contact your local distributor for more advice



CONTACT DETAILS

Ruskinn Technology Limited

Address:

8 & 9 York Park,
Bridgend Industrial Estate
Bridgend CF31 3TB
United Kingdom

Phone: +44 (0)1656 645988

Fax: +44 (0)1656 667966

Email:

Sales: sales@ruskinn.com

Technical support: techsupport@ruskinn.com

General enquiries: ruskinnooffice@ruskinn.com

Website: www.baker.com

Ruskinn Technology Limited is a registered company in United Kingdom, company number 05692599

Ruskinn Technology Limited is VAT registered in United Kingdom, VAT number 870194126

Ruskinn Technology Limited is a wholly owned subsidiary of The Baker Company