

# **Datex-Ohmeda S/5 Light Monitor**

## **User's Reference Manual**



Conformity according to the Council Directive 93/42/EEC concerning medical devices

CAUTION: U.S. Federal and Canadian law restricts this device to sale by or on the order of a licensed medical practitioner. Outside the USA and Canada, check local laws for any restriction that may apply.

Document No. 8000056-2

April 2003

Datex-Ohmeda, Inc.  
P.O. Box 7550, Madison  
WI 53707-7550, USA  
Tel. +1-608-221-1551  
Fax +1-608-222-9147  
[www.us.datex-ohmeda.com](http://www.us.datex-ohmeda.com)

Datex-Ohmeda Division,  
Instrumentarium Corp.  
P.O. Box 900, FIN-00031  
DATEX-OHMEDA, FINLAND  
Tel. +358 10 39411 Fax +358 9 146 3310  
<http://www.datex-ohmeda.com/>

© Instrumentarium Corp. All rights reserved.

## Intended purpose

Datex-Ohmeda S/ 5 Light Monitor is intended for stationary and mobile monitoring of patient's ECG, SpO<sub>2</sub>, non-invasive and invasive blood pressure, temperature, respiration and CO<sub>2</sub> in hospitals and ambulances. When used outdoors, the monitor must be in the protective case.

The monitor is intended for use by qualified medical personnel only.

The S/ 5 Light Monitor is intended for patients with weight from 5 kg (11 lb.) up.

Respiration monitoring is intended for patients three years old and up.

## Classification according to IEC60601-1

- CLASS I EQUIPMENT and INTERNALLY POWERED EQUIPMENT according to the type of protection against electrical shock.
- TYPE B For CF equipment according to the degree of protection against electric shock is indicated with a symbol beside each patient connector.
- Degree of protection against harmful ingress of water as detailed in the IEC60529:  
Monitor: IPX1, vertically falling water drops shall have no harmful effects (applicable when the monitor is in upright position, or tilted backwards). In the protective case IPX4, splash proof, when the case is closed properly, the monitor is intact and operates on battery power.  
Power adapter: IPX0, ordinary equipment.  
Power Adapter for Transport Vehicles: IPX1.
- EQUIPMENT not suitable for use in the presence of a FLAMMABLE ANESTHETIC MIXTURE with air or with oxygen or nitrous oxide.
- CONTINUOUS OPERATION according to the mode of operation.

## Classification according to EU Medical Device Directive

- The monitor is classified as IIb.

## Responsibility of the manufacturer

Instrumentarium Corp. is responsible for the effects on safety, reliability and performance of the equipment only if:

- assembly, operations, extensions, readjustments, modifications, service and repairs are carried out by authorized personnel.
- the electrical installation of the relevant room complies with appropriate requirements.
- the equipment is used in accordance with this manual.

The CO<sub>2</sub> measuring option (N-LQM) is manufactured for Instrumentarium Corp. by Pryon Corp., 8500 S.W. Creekside Place, Beaverton, OR 97008-7107 USA

The Nellcor option (N-LSAT) is manufactured for Instrumentarium Corp. by Mallinckrodt Inc., 675 McDonnell Boulevard, P.O. Box 5840, St. Louis, MO 63134 USA

## Trademarks

ComWheel, Datex-Ohmeda AS/ 3, Datex-Ohmeda CS/ 3, Light, EarSat, FingerSat and Flexite are trademarks of Instrumentarium Corp.

© Instrumentarium Corp. All rights reserved.

---

**Table of contents**

<b>1.</b>	<b>How to Use THIS MANUAL</b>	<b>1</b>
	Related documents.....	1
	Symbols and abbreviations.....	2
	Symbols on the equipment.....	2
	Symbols used in this manual.....	4
	Chapter symbols.....	4
	Abbreviations.....	5
	Conventions used in this manual.....	6
<b>2.</b>	<b>SAFETY</b>	<b>7</b>
	Warnings.....	7
	EXPLOSION HAZARD.....	7
	ELECTRICAL SHOCK HAZARD.....	7
	PATIENT SAFETY.....	8
	Cautions.....	9
	BATTERY CAUTIONS.....	10
<b>3.</b>	<b>Unpacking and Installation</b>	<b>11</b>
	Unpacking.....	11
	Placing.....	11
	Electrical Power Adapter.....	12
	Charge batteries.....	13
	Connecting to network.....	13
	Configuration.....	13
	Disposal.....	14
<b>4.</b>	<b>Description</b>	<b>15</b>
	Parts of the monitor.....	15
	Rear panel.....	16
	Keys and controls.....	17
	ComWheel.....	17
	Display.....	18
	Measurement connectors.....	19
<b>5.</b>	<b>Operation</b>	<b>20</b>
	Getting started.....	20
	During monitoring.....	20
	In-between patients.....	20
	At the end of the day.....	20
	Using menus.....	21

<b>6.</b>	<b>Batteries</b>	<b>22</b>
	Charging batteries.....	22
	Charging in the monitor.....	22
	Removing batteries from the Battery Module.....	23
	Battery alarms.....	23
	Storing and disposing of batteries.....	23
<b>7.</b>	<b>Cleaning</b>	<b>25</b>
	Dust filter.....	26
	Monitor casing.....	26
	Pulse oximetry sensors.....	26
	ECG cables, temperature probes, NIBP hose.....	26
	NIBP cuff.....	27
	Invasive pressure cables.....	27
	Airway accessories.....	27
	Adapters.....	27
	Mainstream CO <sub>2</sub> sensor.....	27
<b>8.</b>	<b>ALARMS</b>	<b>29</b>
	Alarm categories.....	29
	Smart start alarms.....	30
	Silencing alarms.....	30
	Silencing alarms for two minutes.....	31
	Turning audible alarms on and off.....	31
	Alarm messages.....	32
	Alarms setup and adjustments.....	32
	Adjusting alarm limits.....	32
	Other settings.....	33
	Automatic alarm recording.....	33
	Alarm tables.....	34
	Alarm sources.....	34
	Default limits.....	34
	Auto alarm limits.....	36
<b>9.</b>	<b>MONITOR SETUP</b>	<b>38</b>
	Screen setup.....	38
	Selecting waveforms.....	38
	Selecting numerical display fields.....	39
	Setting time & date.....	40
	Install/ Service menu.....	41
	Default settings.....	41

---

<b>10.</b>	<b>TRENDS</b>	<b>45</b>
	Viewing graphic trends .....	46
	Graphic trend pages.....	46
	Viewing numerical trend .....	48
	Changing trend setup.....	49
	Erasing trend data.....	49
<b>11.</b>	<b>Patient Data</b>	<b>50</b>
<b>12.</b>	<b>Recording and Printing</b>	<b>52</b>
	Recording.....	52
	Selecting the waveforms to be recorded.....	52
	Recording trends.....	53
	Other recorder settings.....	53
	Recorder paper replacement.....	54
	Printing.....	54
	Selecting the printer .....	54
	Selecting the paper size .....	55
	Printer installation.....	55
	Printer setup.....	55
<b>13.</b>	<b>Network and DataCard</b>	<b>56</b>
	Networking.....	56
	Patient view and multi view on the Datex-Chmeda Central screen.....	56
	Monitor-to-Monitor communication.....	57
	DataCard.....	57
	Inserting and removing the card .....	57
	Collecting data.....	58
<b>14.</b>	<b>ECG</b>	<b>59</b>
	Monitoring ECG.....	59
	Applying electrodes.....	59
	Patient preparation.....	59
	Placing electrodes.....	60
	Electrode coding .....	60
	Selecting trunk cable .....	61
	What should happen when electrodes are applied ?.....	61
	Selecting ECG lead.....	61
	ECG display.....	61
	Cascaded ECG.....	62
	ECG adjustments .....	62
	ECG setup.....	63
	Setting heart rate alarm.....	64

Pacemaker patients .....	64
<b>15.            Respiration</b>	<b>65</b>
Monitoring respiration.....	65
Patient connections .....	65
Respiration setup .....	65
Limitations of measuring.....	66
Measuring principle.....	67
<b>16.            Pulse Oximetry</b>	<b>68</b>
Monitoring pulse oximetry.....	68
Selecting sensor.....	69
Applying sensors.....	69
What should happen when sensor is applied ?.....	70
Pulse oximetry display.....	70
Measuring limitations .....	70
Adjustments.....	71
Setting SpO <sub>2</sub> alarms .....	72
Measuring principle.....	72
Alternative SpO <sub>2</sub> measurement.....	73
Nellcor® sensors.....	73
<b>17.            TEMPERATURE</b>	<b>74</b>
Monitoring temperature .....	74
Temperature display .....	74
Temperature testing .....	74
Temperature setup.....	75
<b>18.            NON-INVASIVE BLOOD PRESSURE (NIBP)</b>	<b>76</b>
Monitoring NIBP.....	76
Display of NIBP measurement .....	77
Automatic NIBP double check.....	78
Using NIBP functions .....	78
Starting/ Stopping autcycle.....	79
Starting a manual measurement.....	79
Canceling any measurement.....	79
Starting a continuous measurement (STAT).....	80
Using venous stasis.....	80
NIBP adjustments .....	81
Calibration check.....	81
NIBP alarms .....	82
Measuring principle.....	82

---

<b>19.</b>	<b>INVASIVE BLOOD PRESSURE</b>	<b>83</b>
	Monitoring invasive pressures.....	83
	Preparing pressure line.....	83
	Zeroing transducer.....	84
	Invasive pressure display.....	85
	Adjustments.....	86
	Labeling the invasive line.....	86
	Changing the scale.....	87
	Other invasive pressure setup adjustments.....	87
	Invasive pressure alarms.....	88
	Measuring principle.....	88
<b>20.</b>	<b>Carbon Dioxide, CO<sub>2</sub></b>	<b>89</b>
	Monitoring mainstream CO <sub>2</sub> .....	89
	Display of CO <sub>2</sub> measurement.....	90
	CO <sub>2</sub> adjustments.....	91
	Calibration check.....	91
	Unit conversions.....	92
	Measuring principle.....	92
<b>21.</b>	<b>MAINTENANCE AND TROUBLESHOOTING</b>	<b>93</b>
	Maintenance.....	93
	Once a month.....	93
	Once a year.....	93
	Checklist.....	93
	General.....	93
	ECG/ Respiration.....	94
	Pulse oximetry.....	94
	Temperature.....	95
	Non-invasive blood pressure NIBP.....	95
	Invasive blood pressure.....	96
	CO <sub>2</sub> .....	96
	Battery packs and Module.....	96
	Alarm and information messages.....	97
	ECG.....	97
	Impedance respiration.....	98
	Invasive blood pressure.....	98
	NIBP.....	99
	Temperature.....	101
	Pulse oximetry.....	101
	CO <sub>2</sub> .....	102
	DataCard.....	103

Battery.....	104
Recorder .....	104
Other messages.....	105
Troubleshooting.....	106
<b>22. GENERAL SPECIFICATIONS</b>	<b>107</b>
Parameter specifications.....	107
ECG.....	107
Impedance respiration.....	107
Pulse oximetry (SpO <sub>2</sub> )/ Pleth.....	108
Temperature.....	109
Non-invasive blood pressure.....	109
Invasive blood pressure (F-LMIP1 models only).....	110
General .....	111
Environmental conditions.....	112
Display.....	112
Trends.....	113
Alarms.....	113
Light Monitor Battery Module (optional) (w/ 2 battery slots).....	113
S/5 Light Monitor Backup Battery (optional).....	113
External Power Adapter .....	114
Power Adapter for transport vehicles (optional) .....	114
Option codes.....	114
Nurse call and defibrillator synchronization signals .....	115
<b>23. Accessories</b>	<b>117</b>
<b>24. INDEX</b>	<b>i</b>

# 1. HOW TO USE THIS MANUAL

This manual describes how to use and maintain the Datex-Ohmeda S/ 5 Light Monitors F-LM1 and F-LMP1.

The **General** section gives you information about safety aspects and installation. Get acquainted with them before using the monitor.

The **Basic Operation** section helps you through the daily basic use of the monitor.

The **Detailed Operation** section describes the monitor functions in detail. These chapters are necessary if you want to master all the features available in the monitor.

The **Troubleshooting/ Specifications** and **Index** sections help you find the information you need in various situations.

NOTE Before using your monitor, please read this manual. Pay special attention to WARNING and CAUTION statements.

## Related documents

### **S/ 5 Light Monitor Technical Reference Manual**

The Technical Reference Manual provides detailed technical descriptions and instructions for the service, maintenance procedures and troubleshooting.

### **Light Monitor Schematic Diagrams**

The Schematic Diagrams provide schematic diagrams and part layouts for the monitor.

### **Patient Monitor Supplies and Accessories**













The Patient Monitor Supplies and Accessories Catalogue provides information on all supplies and accessories available for the monitor.







## Symbols and abbreviations

### Symbols on the equipment





	Attention, consult accompanying documents.
on the rear panel indicates the warning:	Electric shock hazard. Do not open monitor frame. Refer servicing to qualified personnel. Do not touch any part of the monitor or patient connections during defibrillation procedure. Disconnect power supply before servicing.
on the rear panel dust filter indicates the reminder:	Check rear panel dust filter regularly, and clean at least once a month.
on the patient connector panel indicates the warnings and cautions:	Use only the specified cables and accessories. Ensure proper contact of the return electrode of the electrosurgery unit to your patient to avoid possible burns at ECG electrode or other probe sites. The output signals are not floating and must not be connected directly to a patient.
on the external power adapter indicates the cautions:	For continued protection against fire hazard, replace only with same type and rating of fuse. Make sure voltage selector is set according to local voltage. For indoor use only. For patient transport outdoors, use the monitor in its protective case and with battery power only. Do not immerse in liquid or allow any liquid to enter the interior.
on the battery unit indicates the warnings and cautions:	Do not put in fire. Do not short-circuit any terminals. Do not disassemble or mutilate. Use only with Battery Module or External Battery Charger. Discharge and charge batteries fully once a month to restore full capacity. Sealed NiCd battery must be recycled or disposed of properly. Discharge before disposing.
on the CO <sub>2</sub> sensor:	Do not immerse the sensor in liquids or autoclave it.

	SpO <sub>2</sub> , CO <sub>2</sub> : Type BF (IEC-60601-1) protection against electrical shock, not defibrillation proof.
	NIBP: Type BF (IEC-60601-1) defibrillator-proof protection against electrical shock.
	Temperature: Type CF (IEC-60601-1) protection against electrical shock.
	ECG, Impedance Respiration, P <sub>1</sub> , P <sub>2</sub> : Type CF (IEC-60601-1) defibrillator-proof protection against electrical shock.
 Ni-Cd	Battery packs contain heavy metal cadmium (chemical symbol Cd) and in case of disposal, must be separated from other waste according to local regulations.
 Ni-Cd	Battery packs contain Ni-Cd and they can be recycled.
IPX-class:	Degree of protection against harmful ingress of water as detailed in the IEC 60529:
IPX0	- ordinary equipment
IPX1	- vertically falling water drops shall have no harmful effects
IPX4	- splash proof
	Battery charging LEDs: LEDs are blinking while batteries are being charged and stay illuminated when batteries are fully charged and the monitor is connected to mains.
	The monitor is connected to the network (optional).
	The DataCard (option) is inserted. If symbol is blinking, the card is faulty or it is not inserted properly.
	A blinking heart next to the heart rate or pulse rate value indicates the beats detected.
	A lung next to the respiration rate value indicates that respiration rate is calculated from the impedance respiration measurement.
	Silence alarm indicator. When displayed on the upper left corner of the screen, indicates that all the alarms are silenced. When in the menu or digit fields, indicates that the alarm source has been turned off.
	Alternating current

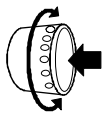

-  Input voltage
-  Output voltage
-  Ethernet connectors
-  Printer connector
-  Sample gas outlet
-  Do not immerse the sensor in liquids.

### **Symbols used in this manual**





-  Indicates the procedure for making adjustments (turn and press) in the menus.
-  Submenu. Selecting a menu item with this symbol opens a new menu.





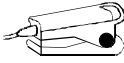

### **Chapter symbols**

#### **General chapters**

-  General information
-  Operation
-  Alarms
-  Trends

#### **Measuring parameter chapters**

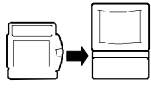
-  ECG
-  NIBP
-  Pulse oximetry
-  Temperature

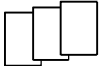
	Recorder		Invasive pressure
	Monitor setup		CO <sub>2</sub>
	Networking and DataCard		Impedance respiration
	Patient data		

## Abbreviations

### Blood pressure:

Art	arterial pressure
CVP	central venous pressure
ICP	intracranial pressure
Inv.	invasive
Mean	mean of diastolic and systolic pressures
NIBP	non-invasive blood pressure
P	blood pressure
PA	pulmonary arterial pressure
S/D	systolic/ diastolic

### Temperature:

Temp	temperature
AirW	airway temperature
Axil	axillary temperature
Blad	bladder temperature
Eso	esophageal temperature
Myo	myocardial temperature
Naso	nasopharyngeal temperature
Rect	rectal temperature
Room	room temperature
Skin	skin temperature
Temp	temperature
Tymp	tympenic temperature
Core	central temperature
Surf	surface temperature

**Miscellaneous:**

Casc	cascaded ECG waveform
ECG	electrocardiography
EL	electroluminescence (display)
HR	heart rate
LED	light emitting diode
Pleth	plethysmograph waveform
P/N	part number
PR	pulse rate
SpO <sub>2</sub>	oxygen saturation measured by pulse oximeter
MS	mainstream CO <sub>2</sub> measurement
SN, S/N	serial number

## **Conventions used in this manual**

Names of the keys appear in bold typeface: **Normal Screen**.

Selectable menu items appear in bold and italic typeface: ***Previous Menu***

Informative messages displayed on the screen are enclosed in single quotes: 'Please wait'.

## 2. SAFETY

### Warnings

**WARNING** Indicates situations in which the user or the patient may be in danger of injury or death.

#### EXPLOSION HAZARD

- Do not use the monitor in presence of flammable anesthetics.

#### ELECTRICAL SHOCK HAZARD

- Do not remove cover. Refer servicing to qualified service personnel.
- Use only hospital-grade grounded electrical outlets and power cord. Grounding reliability can only be achieved when the equipment is connected to a receptacle marked 'hospital grade'.
- Make sure that external equipment is hospital grade grounded before you connect it to the monitor. Do not connect any external equipment to the monitor, except that specified by Datex-Ohmeda.
- When connecting external equipment to monitor, make sure that the whole combination complies with safety standard IEC60601-1-1 for the medical electrical systems and with the requirements of local authorities. A non-medical electrical equipment connected to monitor shall be supplied from an extra separating transformer with a protectively grounded power outlet.
- Before cleaning, disconnect the monitor from electrical outlet.
- Do not immerse any part of the monitor in liquids or allow liquid to enter the interior.
- Do not autoclave any part of the monitor with steam or ethylene oxide.
- After cleaning, or if liquid has accidentally entered the interior of the monitor, make sure that every part of the monitor is dry before reconnecting it to the power supply.

## **PATIENT SAFETY**

- Always make sure that necessary alarm limits are set and operative when you start monitoring.
- When the alarms are suppressed, observe the patient frequently.
- Connect only one patient to one monitor at a time.
- Constant attention by a qualified professional is needed whenever a patient is under anesthesia or connected to a ventilator. Some equipment malfunctions may pass unnoticed in spite of the monitor alarm.
- Do not use antistatic or electrically conductive breathing tubes. They may increase the risk of burns when electrosurgery unit is utilized.
- Do not use the monitor during magnetic resonance imaging (MRI).
- ECG, Impedance Respiration, InvBP. Ensure proper contact of the return electrode of the electrosurgery unit to your patient to avoid possible burns at sensor sites.
- ECG, Impedance Respiration, InvBP. Make sure that no part of the patient connections touches any electrically conductive material including earth.
- Impedance Respiration: In obstructive apnea, thoracic movements and impedance variations may continue.
- NIBP: The monitor sets the inflation pressure automatically according to the first measurement. Reset the case to reset the inflation limit before measuring a new patient.
- **PATIENTS WITH PACEMAKERS OR ARRHYTHMIAS:** Monitor may count the pacemaker pulses as heart beats during cardiac arrest, some arrhythmias, and with certain types of pacemakers particularly in **ONR** mode. Do not rely entirely upon rate meter alarms. Keep patients with pacemakers and arrhythmias under close surveillance.
- **PACEMAKER PATIENTS:** The impedance respiration measurement may cause rate changes in Minute Ventilation Rate Responsive Pacemakers. Set the pacemaker rate responsive mode off or turn off the impedance respiration measurement on the monitor.
- SpO<sub>2</sub>: A damaged sensor or a sensor soaked in liquid may cause burns during electrosurgery.

- SpO<sub>2</sub>: Change measuring site frequently. Change the sensor site and check skin and circulatory status every 2-4 hours with adults and every hour with small children.
- The output signals are not floating and must not be connected directly to a patient.
- Do not use delayed analog signals for defibrillator or intra-aortic balloon pump synchronization.
- The monitor is intended for use by qualified medical personnel only.
- InvBP: All invasive procedures involve risks to the patient. Use aseptic technique. Follow catheter manufacturer's instructions.
- InvBP: Use only defibrillator proof cables and transducers.

## Cautions

**CAUTION** Indicates situations in which the unit or devices connected to it may be damaged.

- Use licensed patient cables and accessories only, see Patient Monitor supplies and accessories catalogue. Other cables and accessories may damage the system or interfere with measurement.
- Before connecting the power cord, ensure that the input voltage selector is set correctly in the external power adapter.
- Use the monitor outdoors with the battery power only.
- Do not store the monitor beyond the specified temperature range.
- Do not use hypochlorite, ammonia-, phenol- or acetone-based cleaners. They may damage the monitor.
- Clean rear panel fan dust filter once a month or whenever needed.
- Leave space around the monitor for ventilation to prevent the monitor from overheating.
- Do not apply pressurized air to any outlet or tubing connected to the monitor. Pressure may destroy sensitive elements.
- When used in moving vehicle, mount the monitor properly.
- Dispose of the device and parts thereof in accordance with local regulations.

- Vibrations during transport may disturb SpO<sub>2</sub>, ECG, impedance respiration and NIBP measurements.
- CO<sub>2</sub>, SpO<sub>2</sub>: Do not apply force to sensors or sensor cables.
- DataCards: Do not subject cards to excessive heat, bending, or magnetic fields.
- InvBP: Mechanical shock to invasive blood pressure transducer may cause severe shifts in zero balance and calibration and produce erroneous readings.
- Electromagnetic interference from radio-frequency transmitting devices in ambulances may affect the performance of this medical device.

### **BATTERY CAUTIONS**

- Do not put in fire.
- Do not short-circuit any terminals.
- Do not use damaged or leaking batteries.
- Do not disassemble or break the batteries.
- Use only with Battery Module or External Battery Charger.
- Charge and discharge batteries fully once a month to restore full capacity.
- Sealed NiCd battery must be recycled or disposed of properly. Discharge before disposing.

### 3. UNPACKING AND INSTALLATION

#### Unpacking

The monitor is delivered in one box containing typically (as minimum):

- Datex-Ohmeda S/5 Light Monitor
- Datex-Ohmeda S/5 Light Monitor Power Adapter with power cord or optional Power Adapter for Transport Vehicles
- User's Reference Manual

Check that the contents correspond to your order and that all additional options you have ordered are included. If any of the items appears damaged or is missing, contact your sales person immediately.

#### Placing

The monitor can be placed on a flat surface or hung with the handle from bed or wall rails. Make sure that the surface or rail holds up to at least 10 kg/ 22 lb.

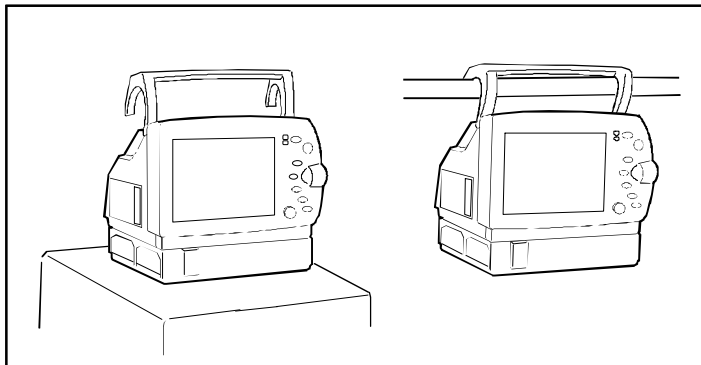

**Figure 3-1** Installation

A protective case is also available. If using the case, make sure that the monitor is always in a standing position to ensure proper ventilation. The monitor is splash-proof (IPX4) when it is in the protective case and all the openings of the case are closed properly. Make sure the monitor is intact and operates on battery power. When used outdoors, the monitor must be in the protective case.

**NOTE:** The pocket in the protective case is not water-proof. Do not place items in the pocket that may be damaged by moisture.

Universal mounting solutions are sold separately. Contact your local distributor.

## Electrical Power Adapter

Use only the power cord and power adapter provided with the monitor.

- Set the voltage selector on the adapter to the right position (115V/230V) e.g. with a pen.
- Connect the adapter cord to the connector on the rear panel.
- Connect the power cord to the adapter and then plug onto the wall electrical outlet.

**NOTE:** To use the power adapter, it must be lying on a flat surface or hanging from the holder.

Do not let any liquid enter the adapter.

When external power supply is in use, a green led is lit.

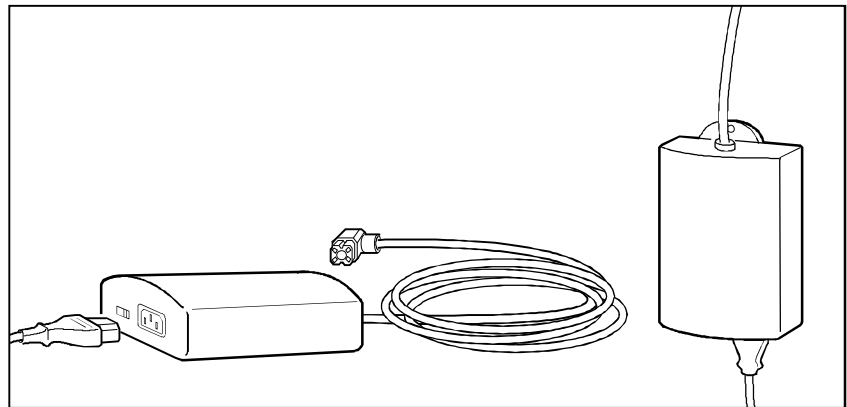

Figure 3-2 Placing Power Adapter

### WARNING

**ELECTRICAL SHOCK HAZARD:** Use only hospital grade grounded electrical outlets.



### CAUTION

Before connecting the power cord, ensure that the input voltage selector is set correctly in the power adapter.

In vehicles with 12 - 32 V power source, use the Power Adapter for Transport Vehicles, N-LPOWT. For information on how to install and use this adapter, refer to the instruction sheet provided with it, or contact your local distributor.

**CAUTION** Electromagnetic interference from radio-frequency transmitting devices in ambulances may affect the performance of this medical device.

### Charge batteries

Keep the monitor connected to the mains outlet. The batteries are fully charged when the battery capacity indicators on the screen show FULL and green LEDs in the Battery Module stop flashing.

**CAUTION** When stored for longer periods, or used mostly with mains power, charge and discharge the batteries fully once a month.

### Connecting to network

The monitor can be connected to a monitor network for central monitoring and printing services.

- Connect the Ethernet and location ID plug to the corresponding connectors on the monitor's rear panel.
- Configure the location IDs in the Datex-Ohmeda Central.

When the monitor is connected to the network and turned on, the network symbol is displayed on the upper right corner of the screen:



### Configuration

When the monitor is delivered, it is configured with the factory default settings and is ready to use.

If you want to change the settings and make your own permanent configuration, refer to chapters "Alarms" and "Monitor setup" of this manual.

### Disposal

Dispose of the monitor, or parts of it, in accordance with local environmental and waste disposal regulations.



## 4. DESCRIPTION

### Parts of the monitor

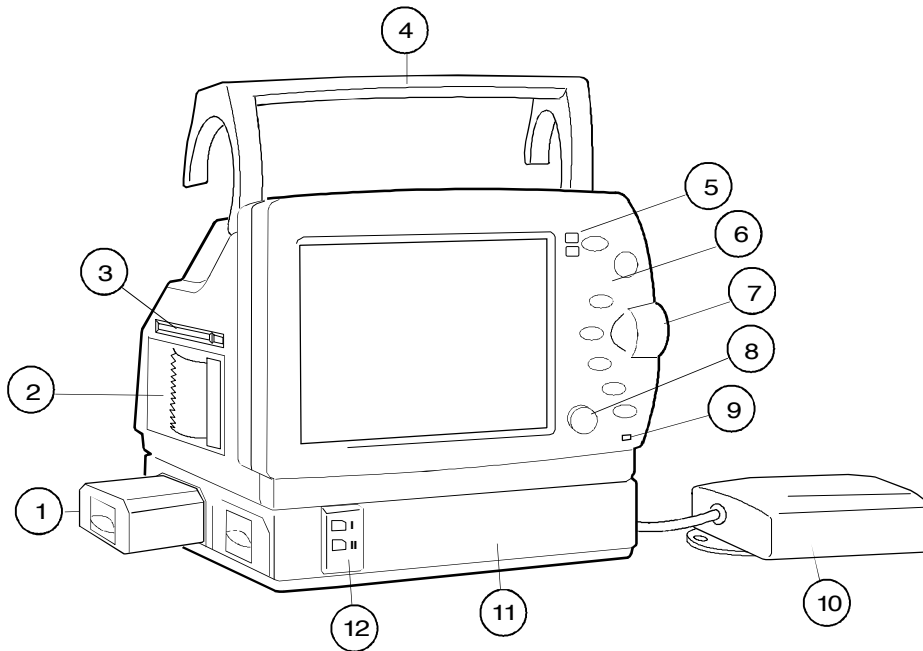

**Figure 4-1 S/5 Light Monitor**

- (1) Battery (2 pieces)
- (2) Recorder (option)
- (3) DataCard slot (option)
- (4) Handle with rail hooks
- (5) Alarm indicators
- (6) Function keys
- (7) ComWheel
- (8) Power On/ Standby
- (9) External power indicator
- (10) External power adapter, or Power Adapter for Transport Vehicles
- (11) Battery Module (option)
- (12) Battery charge status LEDs

## Rear panel

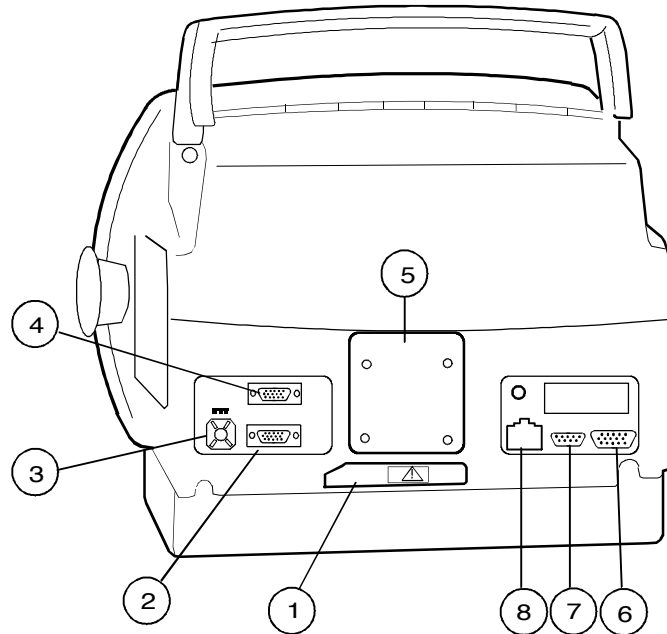











Figure 4-2 Rear panel

- (1) Dust filter 
- (2) Feature connector, X3
- (3) Connector for power adapter, X1
- (4) Printer connector (serial), X2
- (5) Mounting attachment
- (6) External VGA connector, X7
- (7) Connector for network location ID plug, X6
- (8) Network connector, X5

## Keys and controls

	On/ Standby.
	Returns back to normal monitoring display.
	Silences the alarm sound for two minutes.
	Calls up the main menu which enables changing the monitor settings.
	Opens NIBP mini menu for autocycling or a single non-invasive blood pressure measurement. Cancels any NIBP measurement.
	Zeroes all invasive pressure lines (except ICP which needs to be zeroed separately, see chapter “ <i>Invasive pressure</i> ”).
	Stops the waveform sweep for 60 seconds. Pressing it again unfreezes the sweep.
	Starts/ stops recording of selected waveforms with the built-in recorder.

## ComWheel

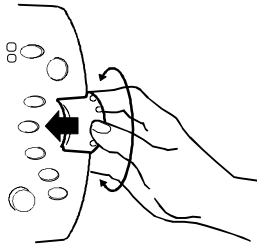

Menu functions are controlled by turning and pressing the ComWheel.

## Display

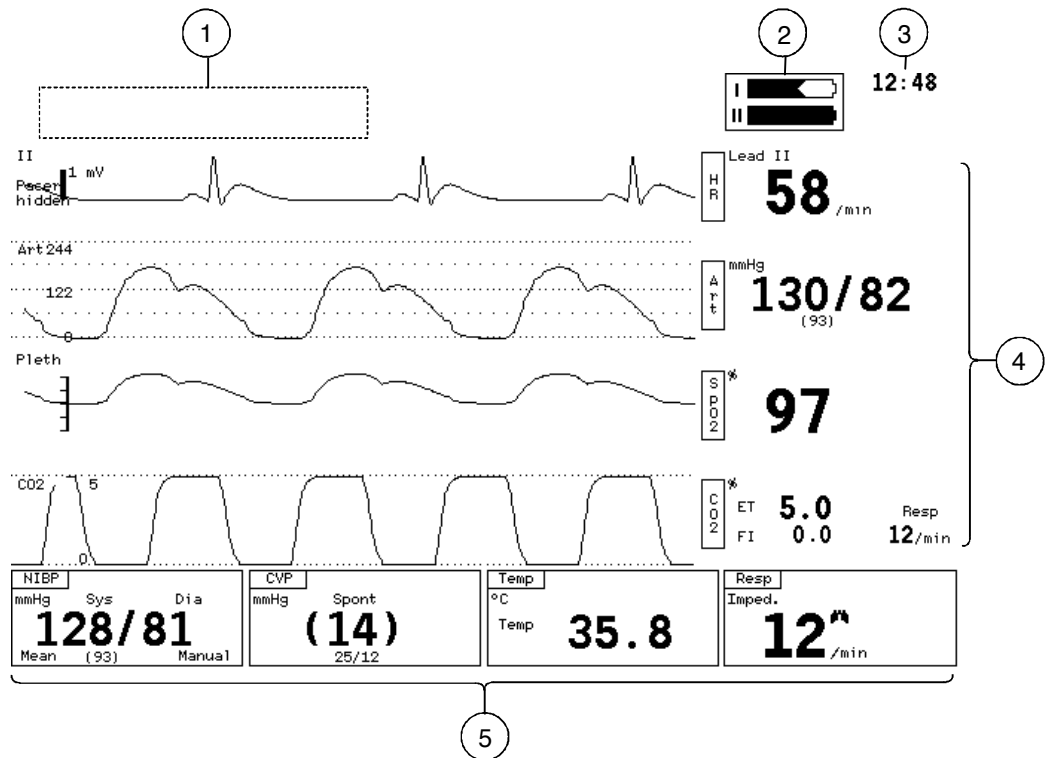

**Figure 4-3 Parts of the display**

- (1) Alarm message field (for five messages)
- (2) Battery status field
- (3) Actual time
- (4) Up to four waveform fields with numeric information
- (5) Up to four digit fields

The waveform and digit fields are configurable, see chapter "Monitor setup."

## Measurement connectors

Connectors for measurement sensors are in the right side panel. Connectors are marked with the measurement abbreviations and symbols specifying the type of protection against electrical shock.

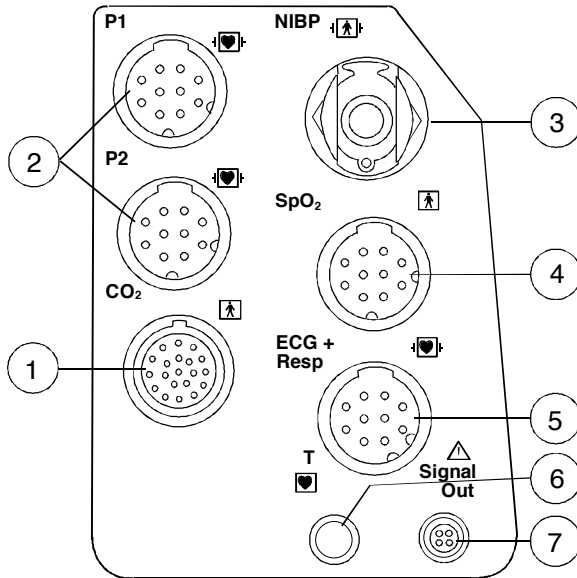

**Figure 4-4 Connector panel**

- (1) Mainstream CO<sub>2</sub> connector
- (2) Connectors for invasive pressure lines
- (3) NIBP hose connector
- (4) Pulse oximetry sensor connector
- (5) ECG trunk cable connector, also used for impedance respiration measurement
- (6) Temperature probe connector
- (7) Signal out connector 

## 5. OPERATION

### Getting started

- Turn on the power.

After 10 seconds a start-up display will appear, the CO<sub>2</sub> measurement needs to warm up about 80 seconds in room temperature. If the monitor has been stored in the temperature below freezing point, it takes approximately one hour to warm up.

- Make patient connections, check the accessories.
- Zero invasive lines.
- Check that desired parameters are displayed in digit and waveform fields. If necessary, make appropriate adjustments.

### During monitoring

- Ensure that ECG electrodes have a good skin contact.
- Change pulse oximetry measuring site frequently.
- Observe the cuffed limb frequently during NIBP measurement.
- If the monitor is connected to the network, the patient information and alarms can be followed on the screens of the Datex-Ohmeda Central and the S/5 monitors connected to the system.

### In-between patients

- Print trends: see chapter "Recorder."
- Reset previous case: Press **Menu** and select **Patient Data - Reset ALL**.
- Change single use accessories; clean reusable ones.
- Check the monitor and accessories before use.
- Plug in the power cord to charge batteries.

### At the end of the day

- Turn the monitor to standby.
- Remove the power cord.
- Clean the monitor and reusable accessories. Let dry completely.
- Plug in the power cord to charge batteries.

## Using menus

- Press the **Menu** key.

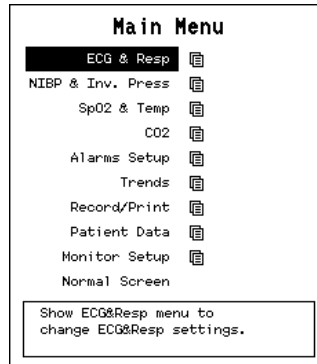

- Select the item by turning and pressing the **ComWheel**.

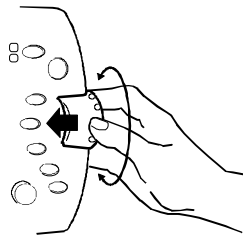

- Change settings by turning and pressing the **ComWheel**.

Need help?  
Short instructions appear in every menu.

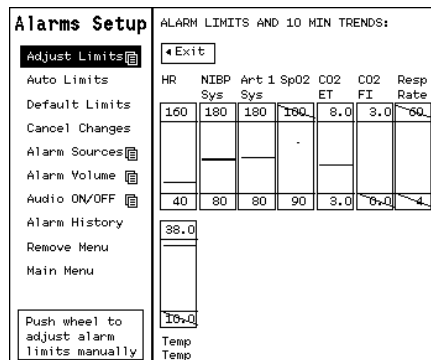

- Press **Normal Screen**.

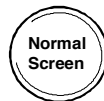

## 6. BATTERIES

The monitor can be equipped with either the Battery Module (F-LBAT) with two removable batteries, or the Backup Battery (N-LBB) with a built-in battery pack in the monitor basement.

Battery capacity is displayed on the battery status field. The arrow shows the discharging (left) and recharging (right) level of the battery.



The Battery Module works for two hours (one hour / battery) and Backup Battery for 30 minutes with fully charged batteries.

NOTE: Make sure that there is enough battery capacity for a patient transport.

### Charging batteries

- Charge the batteries in +10...40 °C (50...104 °F) only.

### Charging in the monitor

- Keep the monitor connected to power outlet. The batteries are charged when the monitor is either ON or STANDBY.
- If monitor is turned ON, an arrow to the right is displayed on the Battery Status field during charging.
- The green LEDs on the battery module keep flashing until the battery is fully charged.

Charging empty batteries to full capacity for Battery Module takes approximately 3.5 hours/ battery, and for Backup Battery 1.5 hours. The protective case may increase the operating temperature so check the charging status when using it.

## Removing batteries from the Battery Module

- Push the release latch down.
- The battery pops out from the frame.

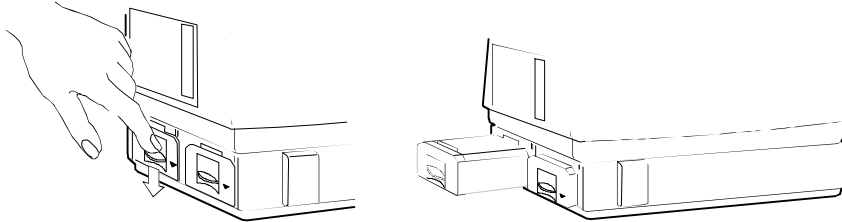

**Figure 6-1** Removing battery packs from the Battery Module

Replace the batteries with new ones if the total operation time is less than one hour. Part number is 896895.

## Battery alarms

If something out of normal routine happens, a corresponding message appears. These battery alarm and note messages are explained in chapter “*Maintenance and troubleshooting.*”

## Storing and disposing of batteries

Keep the batteries in the monitor or external charger. If they are stored for longer periods, store them fully charged in a dry place. Before use, charge them fully.

- CAUTION** Do not put in fire.
- CAUTION** Do not short-circuit any terminals.
- CAUTION** Do not disassemble or mutilate.
- CAUTION** Use only with Battery Module or External Battery Charger.
- CAUTION** Do not insert any other than specified batteries into Battery Module or External Charger.

When stored for longer periods or used mostly with mains power; charge and discharge the batteries fully once a month.



**Ni-Cd**

This battery contains heavy metal cadmium (Cd), and when disposed, must be separated from other waste according to local regulations.



**Ni-Cd**

Battery packs can be recycled. Discharge before disposing.

## 7. CLEANING

**WARNING ELECTRICAL SHOCK HAZARD:**  
**Before cleaning, disconnect the monitor from electrical outlet. Do not immerse any part of the monitor in liquids or allow liquid to enter the interior. Do not autoclave any part of the monitor with steam or ethylene oxide. After cleaning, or if liquid has accidentally entered the interior of the monitor, make sure that every part of the monitor is dry before reconnecting it to the power supply.**

**CAUTION** Do not use hypochlorite, acetone-, phenol-, or ammonia-based cleaners.

<b>Cleaning</b>		
<b>Why?</b>	<b>Which items ?</b>	<b>How?</b>
To remove dirt and most microbes.	All parts daily. The items to be disinfected or sterilized.	<p><b>NOTE:</b> Always detach accessories from the monitor and the patient before cleaning.</p> <ul style="list-style-type: none"> <li>Wipe away visible organic material using a moist cloth and mild detergent, e.g. Datex-Ohmeda Cleaning Fluid.</li> <li>Rinse as recommended by the detergent manufacturer.</li> <li>Allow to dry completely.</li> </ul>
<b>Disinfecting</b>		
To kill and remove pathogenic microbes.	Accessories and supplies in contact with the patient's skin or airways.	<p><b>With heat:</b></p> <ul style="list-style-type: none"> <li>Wash in a washing machine (at least 1 min at 85° C / 185° F).</li> </ul> <p><b>With chemicals:</b></p> <ol style="list-style-type: none"> <li>Immerse in 2% glutaraldehyde for 10 minutes (pH=6.5). After tuberculosis, HIV or hepatitis patient, the treatment time should be 20 min.</li> <li>Rinse carefully and let dry.</li> </ol> <p>or</p> <ul style="list-style-type: none"> <li>Wipe with alcohol and let dry.</li> </ul>
<b>Sterilization</b>		
To kill the microbes and bacterial spores.	Accessories and supplies penetrating the patient's tissue.	<ul style="list-style-type: none"> <li>Steam autoclave at maximum 121° C (250° F) for 15 min.</li> <li>Use ethylene oxide mixture at 50 to 60° C (120 to 140° F). Follow the sterilizer manufacturer's recommendations for required aeration times.</li> <li>Immerse in 2% glutaraldehyde for three hours, rinse carefully and let dry.</li> </ul>

## **Dust filter**

Clean the dust filter at least once a month:

1. Pull out the filter frame on the rear panel. Do not remove any screws!
2. Shake the filter and blow out the dust.

If the filter is damaged, replace it with a new one (p/ n 886841).

## **Monitor casing**

1. Wipe gently using a moist cloth and mild detergent.
2. Let dry completely before reconnecting the power cord.

## **Pulse oximetry sensors**

1. Wipe the sensor with mild detergent solution.
2. Allow it to dry completely before use.

The Sat Sensors may be sterilized using ethylene oxide.

The Sat Sensors are latex free. Take possible patient allergies into account also when selecting the cleaning agent.

With the option using Nellcor sensors, see instructions in the sensor package.

**WARNING PATIENT SAFETY: A damaged sensor, or a sensor soaked in liquid, may cause burns during electrosurgery.**

## **ECG cables, temperature probes, NIBP hose**

Wipe the cables with mild detergent solution. When necessary, use disinfectant.

Always follow the manufacturer's instructions. Disinfect only the items that tolerate the process.

## **NBP cuff**

Clean only when necessary:

1. Remove the bladder from the cuff.

2. Wash the bladder and the cuff in mild detergent solution. Do NOT use alcohol.

## Invasive pressure cables

1. Wipe the cables with sterile alcohol-based detergent.
2. After cleaning wipe the surfaces with a cloth dampened with sterile water. Dry with a dry cloth.

## Airway accessories

### Adapters

Replace the single patient use adapter after each patient.

If the adapter is occluded, it can be rinsed with water and air dried. It may then be replaced into the ventilator circuit of the same patient.

Multi-use adapters can be rinsed with water and steam autoclaved. The adapter is designed to withstand 20 sterilization cycles. Before using, check that the adapter windows are dry and residue-free and that the adapter has not been damaged.

Make sure that all traces of alcohol or detergent are rinsed away or dried before connecting to the patient.

### Mainstream CO<sub>2</sub> sensor

**WARNING** **ELECTRICAL SHOCK HAZARD: Do not immerse the sensor in liquids or autoclave it.**

Wipe the sensor with a slightly damp cotton swab. When necessary, use disinfectant.



## 8. ALARMS

In alarm:

- Messages (max. five messages) appear on the alarm message field at the top of the display in the priority order from left to right.
- Audible alarm is heard.
- External Nurse Call signal is active, and if the monitor is connected to the network, the alarm is passed into it.
- Yellow or red alarm indicator (LED) next to the **Silence Alarms** key is illuminated according to the alarm category.
- The measured value, which activates the alarm, flashes and an explanation may appear on the waveform, the digit field, or the alarm message field.

Alarms are active also when the parameter is not selected on the screen unless the alarm source is not turned off. See default settings in “*Alarm tables/ alarm sources*” later in this chapter.

**WARNING**    **PATIENT SAFETY: Always make sure that alarm limits are set and alarms are on when monitoring a patient.**

### Alarm categories

Alarms are classified into two types, red and yellow alarms. The alarm type depends primarily upon the physiological significance and the duration of the alarm; e.g., ‘Asystole’ advances rapidly to the red category.

The alarm messages are displayed in the order of priority from left to right.

Audio alarms follow either General or ISO pattern. This selection can be made in **Install/Service** menu and is stored in permanent memory. Select the same pattern for all the monitors in a hospital.

**Table 8-1 Alarm priority categories**

Category	Visual	Audio pattern		Meaning
Red alarm	Red LED If the alarm is connected to measured values, this number field is flashed.	ISO: 3+2 beeps every 6 seconds. -----	General: Continuous string of beeps. -----	Life threatening situation.
Yellow alarm	Yellow LED If the alarm is connected to measured values, this number field is flashed.	Triple beep every 20 seconds. --- ---	Double beep every 5 seconds. -- -- -- --	Serious problem.
Note	Message is displayed.	Single beep. -	Single beep. -	Advisory note or equipment related alarm.

### Smart start alarms

Alarms are automatically active once the patient connection cables are attached. Some alarms have their own specific requirements before they become active:

- Invasive pressures must be within alarm limits for 20 seconds after zeroing.
- Apnea alarm requires at least three detected breaths.
- When apnea alarm is activated, the high and low alarms of CO<sub>2</sub> and respiration will not be activated.

### Silencing alarms

**WARNING PATIENT SAFETY: Do not turn off audible alarms without assuming continuous, direct observation of the patient.**

Silencing alarms also disables the external Nurse Call signal.

## Silencing alarms for two minutes

- Press **Silence Alarms**.

The symbol  with a countdown timer appears on the screen, and the message is cleared from the display. Messages of new alarms also appear during silencing period. After two minutes, all silenced alarms and Nurse Call function will return to normal alarm operation.

### To reactivate alarms:

- Press the **Silence Alarms** key during the silencing period.

The alarm sounds of new alarms and the Nurse Call signal are activated.

## Turning audible alarms on and off

It is possible to silence only apnea, ECG and apnea alarms, or all the alarms:

- Press **Menu**.
- Select **Alarms Setup**.
- Select **Audio ON OFF**.
- Select **Silence ECG**, **Silence Apnea**, **Silence Apnea + ECG** or **Silence ALL**.

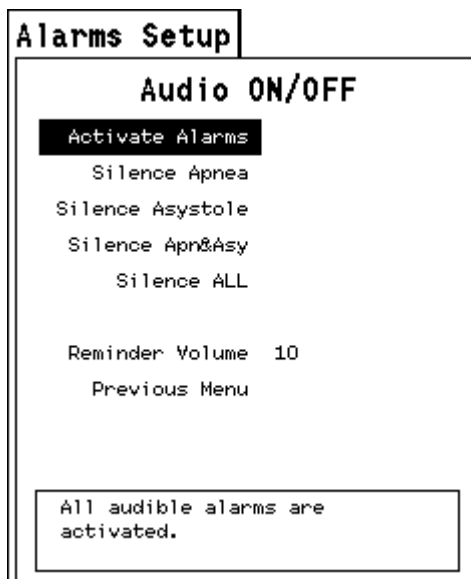



- Select the desired high or low alarm limit by turning and pressing the ComWheel.
- Adjust the alarm limit up or down by turning the wheel.
- Press the wheel to confirm the adjusted alarm limit.
- Turn the ComWheel to move the highlight either to the next alarm limit or to the **Exit** box.
- Press the ComWheel.
- Press **Normal Screen** to return to normal monitoring.

### To set auto limits

Auto limits are calculated from the measured patient values at the time when auto limits are selected. These limits enable close patient control with individual alarms.

- Select **Auto Limits**
- Press **Normal Screen**.

### Other settings

**Default Limits** Sets the alarms to the default alarm limits.

**Cancel Changes** Returns all the values to those that were valid when the **Alarms Setup** menu was entered.

**Alarm Sources** NIBP and invasive pressure alarms have alternative sources, (systolic, diastolic, mean pressure, or OFF).

**Alarm Volume** The volume of the audio alarms can be adjusted from 1 (soft) to 10 (loud).

**Audio ON OFF** All alarms or asystole alone can be turned on and off.

**Alarm History** Displays a list of the last 10 alarms message with respective times. Press the ComWheel to get back to **Alarms Setup** menu.

**Remove Menu** Only the alarm limits and 10 minute trends are displayed.

### Automatic alarm recording

You can record following alarm situations:

1. Asystole
2. HR high/ low and Art low simultaneously (in model with invasive pressure)

When the alarm reaches red state, the recorder will print the ECG+ P1 waveforms. Printing appears 12 seconds after the alarm situation has started.

To set alarm recording, press **Menu** and select  
**Record&Print - Recorder Setup - Start on Alarms YES/ NO**

## Alarm tables

### Alarmsources

If alarm source is OFF, no alarms of this parameter occur and the parameter box with the 10 minute trend is not displayed in the **Alarm Setup** menu.

**Table 8-2 Alarm source alternatives and defaults**

Alarm	Source alternatives [Default selection]
P1	[Sys] Dia Mean OFF
P2	Sys Dia Mean [OFF]
Art	[Sys] Dia Mean OFF
OMP	Sys Dia Mean [OFF]
PA	Sys Dia Mean [OFF]
ICP	Sys Dia Mean [OFF]
NBP	[Sys] Dia Mean OFF

### Default limits

The monitor is delivered with a certain set of alarm limits, so called factory default limits. These are listed for each parameter in the following tables.

It is possible to save alarm adjustments as defaults, see chapter "Monitor setup", submenu "Install/ Service menu."

Do not change default settings without common consent of all users. If you change the default alarm limit, write the new limits in the following table.

**Table 8-3 Adjustment ranges and default settings of alarm limits**

Parameter	Limit	Limit range min-max	Factory default	User default
HR	High Low	35-250 bpm 30-245 bpm	160 40	
SpO <sub>2</sub>	High Low	51-100 % OFF 50-100 %	OFF 90	
NBP	Sys High Low	15-265, OFF OFF; 15-265	180 (120 infant) 80(70 infant)	

	Mean	High Low	15-265, OFF OFF, 15-265	140(90 infant) 60(50 infant)	
	Dia	High Low	15-265, OFF OFF, 15-265	100(70 infant) 40(40 infant)	
Inv-P1	Sys	High Low	-40 -300, OFF OFF, -40-300	180 80	
	Mean	High Low	-40 -300, OFF OFF, -40-300	140 60	
	Dia	High Low	-40 -300, OFF OFF, -40-300	100 40	
Inv-P2	Sys	High Low	-40 -300, OFF OFF, -40-300	20 5	
	Mean	High Low	-40 -300, OFF OFF, -40-300	15 0	
	Dia	High Low	-40 -300, OFF OFF, -40-300	10 -5	
At	Sys	High Low	-40 -300, OFF OFF, -40-300	180 80	
	Mean	High Low	-40 -300, OFF OFF, -40-300	140 60	
	Dia	High Low	-40 -300, OFF OFF, -40-300	100 40	
OP	Sys	High Low	-40 -300, OFF OFF, -40-300	20 5	
	Mean	High Low	-40 -300, OFF OFF, -40-300	15 0	
	Dia	High Low	-40 -300, OFF OFF, -40-300	10 0	
PA	Sys	High Low	-40 -300, OFF OFF, -40-300	40 10	
	Mean	High Low	-40 -300, OFF OFF, -40-300	30 5	
	Dia	High Low	-40 -300, OFF OFF, -40-300	20 5	
ICP	Sys	High Low	-40 -300, OFF OFF, -40-300	20 0	
	Mean	High Low	-40 -300, OFF OFF, -40-300	15 0	
	Dia	High Low	-40 -300, OFF OFF, -40-300	10 0	
EtCO <sub>2</sub>		High Low	0.1 - 13% OFF OFF, 0 - 12.9%	8%(60 mmHg, 8.1 kPa) 3%(23 mmHg, 3 kPa)	
FtCO <sub>2</sub>		High Low	0 - 3.0 % OFF OFF, 0 - 2.9%	3%(23 mmHg, 3 kPa) OFF	
Resp		High Low	5 - 60, OFF OFF, 4 - 59	60 4	
Temp		High  Low	10 - 45 °C, OFF (50 - 113 °F, OFF) OFF, 10 - 45 °C (OFF, 50 - 113 °F)	38 °C(100 °F)  15 °C(59 °F)	

## Autoalarmlimits

**Auto Limits** are based on the measured patient values according to the following tables.

**Table 8-4 Autoalarmlimits**

Alarm	Limit	Auto limit calculation
HR	High Low	HRx1.25 HRx0.75
Pulse Oximetry	Low	SpO <sub>2</sub> - 5%
NBP Sys	High Low	NBPx1.25 + 10 NBPx0.75 - 10
Mean	High Low	NBPx1.25 + 10 NBPx0.75 - 10
Diast	High Low	NBP1.25 + 10 NBPx0.75 - 10
Inv-P1 Sys	High Low	P1x1.25 + 10 P1 x0.75 - 10
Mean	High Low	P1 x1.25 + 10 P1 x0.75 - 10
Diast	High Low	P1 x1.25 + 10 P1 x0.75 - 10
Inv-P2 Sys	High Low	P2 x1.25 + 5 P2 x0.75 - 5
Mean	High Low	P2 x1.25 + 5 P2 x0.75 - 5
Diast	High Low	P2 x1.25 + 5 P2 x0.75 - 5
Art Sys	High Low	P1 x1.25 + 10 P1 x0.75 - 10
Mean	High Low	P1 x1.25 + 10 P1 x0.75 - 10
Diast	High Low	P1x1.25 + 10 P1 x0.75 - 10
CVP Sys	High Low	CVPx1.25 + 5 CVPx0.75 - 5
Mean	High Low	CVPx1.25 + 5 CVPx0.75 - 5
Diast	High Low	CVPx1.25 + 5 CVPx0.75 - 5

PA	Sys	High Low	PAx1.25 +10 PAx0.75 -10
	Mean	High Low	PAx1.25 +10 PAx0.75 -10
	Dia	High Low	PAx1.25 +10 PAx0.75 -10
ICP	Sys	High Low	ICPx1.25 +5 ICPx0.75 -5
	Mean	High Low	ICPx1.25 +5 ICPx0.75 -5
	Dia	High Low	ICPx1.25 +5 ICPx0.75 -5
E <sub>CO<sub>2</sub></sub>		High Low	E <sub>CO<sub>2</sub></sub> +1% E <sub>CO<sub>2</sub></sub> -1%
F <sub>CO<sub>2</sub></sub>		High	OFF
Resp		High Low	RR* 1.25 +2 RR* .75 -2
Temp		High Low	Temp +1 °C(1.8 °F) Temp +1 °C(1.8 °F)

## 9. MONITOR SETUP

The **Monitor Setup** menu enables you to select the information displayed on the screen, to set the time and date and to change the default settings via the **Install/ Service** menu.

Getting to **Monitor Setup**.

- Press **Menu**.
- Select **Monitor Setup**.

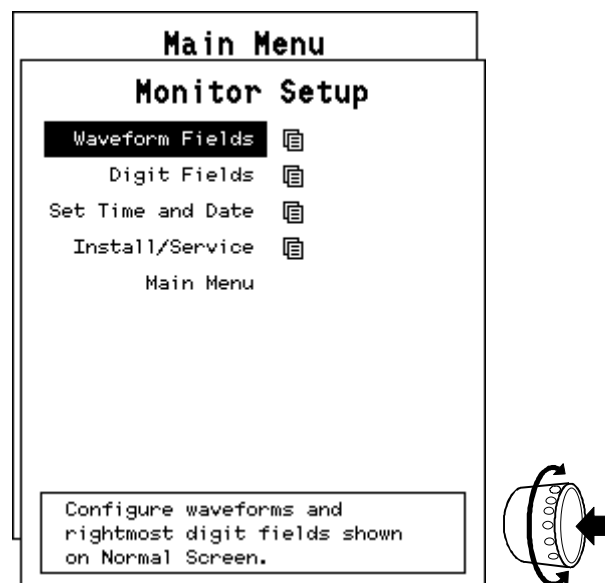

### Screen setup

Select the parameters displayed in the waveform and lower digit fields. A parameter can be displayed in one place only at the time.

The monitor turns to the default settings every time it is turned off. If you want to save a certain screen setup as default, see **Install/ Service** adjustments later in this chapter.

### Selecting waveforms

Four waveforms can be displayed. If one field is set to 'OFF', the remaining waveforms are enlarged to fill the area.



**Monitor Setup**

**Waveform Fields**

<b>Field 1</b>	ECG
Field 2	P1
Field 3	P2
Field 4	Pleth

Combine Pressures	NO
Thick Waves	YES
Previous Menu	

Change the waveform in field 1.  
To clear field, select OFF.

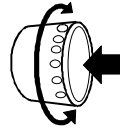

- Select **Waveform Fields**
- Select the field you want to rearrange.
- Select the parameter from the list.
- Press **Normal Screen**.

Selecting **Combine Pressures YES** displays invasive pressures in the same field (only in models with invasive pressure).

Selecting **Thick Waves YES** draws the displayed waveforms with thicker trace.

### Selecting numerical display fields

There are four fields in the lower part of the screen for numeral information, fields are numbered from left to right. If a digit field is turned OFF the digit field to its left is automatically enlarged to fill the space.

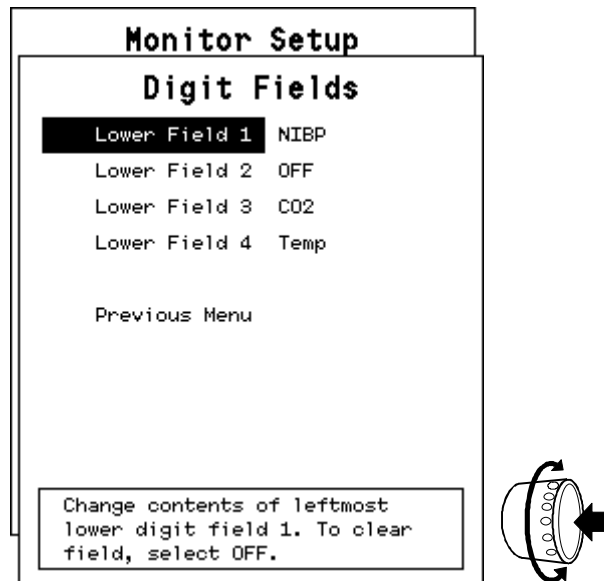

- Select **Digit Fields**
- Select the field you want to rearrange.
- Select the parameter from the displayed list.
- Press **Normal Screen**.

## Setting time & date

- Press **Menu**. Select **Monitor Setup - Set Time and Date**.

The time is shown in the upper right corner of the screen. Turning the monitor off does not affect the clock.

You can adjust hours, minutes, seconds, day, month, and year, or select the clock format of either 12 or 24 hours.

### CAUTION

Do not change the monitor's time settings during patient monitoring. Trend data may be lost.

**NOTE:** If the monitor is connected to network, the time is set by the network, and cannot be adjusted in the monitor.

## Install/ Service menu

To enter **Install/Service** menu, a password 16-4-34 must be given.

**Service View** Service View is for a qualified technician only. It is entered with a password.

**Alarm Tones** Select **ISO** or **General** pattern, see chapter "Alarms."

### Save As Defaults

Saves permanently your new settings and configurations.

The choices are **Save ALL**, **Screen Setup**, **Trend Setup**, **Alarm Settings**, **Recorder Setup** and **Param. Defaults**

Select **Save** to save settings, **Cancel** to cancel changes, or **Factory** to return to the factory settings.

**Analog outputs** Select the parameter for four analog outputs, as default, they all are off.

Channel	Pin	Selection range
1	#3 in Signal Out connector	ECG or test signals
2	#4 in Signal Out connector	P1 or test signals
3	#5 in feature connector	freely selectable
4	#10 in feature connector	freely selectable

**Previous Menu** Return to **Monitor Setup** menu.

## Default settings

Default settings are always on when the monitor is turned on. They are marked in the following tables with brackets.

If you change the default settings using **Save as Defaults**, please write them down in the empty column. Do not change default settings without common consent of all users.

**Table 9-1 Monitor setup selections and factory defaults**

Monitor settings		
Parameter	Alternatives [Default selection]	User default
<b>Waveform Fields</b>		
Field 1	OFF [ECG] P1 P2 PLETH CO2 Resp	
Field 2	[OFF] ECG P1 P2 PLETH CO2 Resp (* P1, ** P1eth, *** P1)	
Field 3	OFF ECG P1 P2 [PLETH] CO2 Resp (** CO2)	
Field 4	[OFF] ECG P1 P2 PLETH CO2 Resp (** CO2)	
Combine Pressures	YES [NO]	
Thick Waves	[YES] NO	
<b>Digit Fields</b>		
Lower Field 1	OFF HR P1 P2 [NIBP] SpO2 CO2 Resp Temp	

Lower Field 2	[OFF] HR P1 P2 NIBP SpO2 CO2 Resp Temp(* P2, *** P2)	
Lower Field 3	OFF HR P1 P2 NIBP SpO2 CO2 Resp [Temp]	
Lower Field 4	OFF HR P1 P2 NIBP SpO2 CO2 [Resp] Temp(** OFF)	
<b>Set Time and Date</b>		
Clock Format	12 [24]	
<b>Parameter settings</b>		
<b>ECG</b>		
ECGLead	I [II] III	
Size	[1.0] 0.2-5.0	
Beat Sound Volume	[0] 0-10	
<b>ECG Setup</b>		
Sweep Speed	12.5 [25] 50	
HR Source	[AUTO] ECG Pleth	
Grid	ON [OFF]	
Pacemaker	Show [Hide] Ch R	
<b>Pulse Oximetry</b>		
Beat Sound Volume	[0] 0-10	
Pleth Scale ****	AUTO 50 [20] 10 5 2	
<b>SpO2/ Pleth Setup</b>		
Sweep Speed	12.5 [25] 50	
HR Source	[AUTO] ECG Pleth	
SpO2 Response	B-to-B Normal [Slow] with N-LSAT selections are: Fast Normal [Slow]	
<b>Temperature</b>		
<b>Temp Setup</b>		
Unit	[°C] °F	
Label	[Temp] Eso Naso Tymp Rect Blad Axil Skin AirW Room Myo Core Surf	
<b>Invasive Pressures</b>		
<b>P1 Setup</b>		
Label	P1 [Art] CVP ICP PA	
Scale	[200] 10-300	
Digit Format	[S/D] Mean	
Sweep Speed	12.5 [25] 50	
HR Source	[AUTO] ECG Pleth	
<b>P2 Setup</b>		
Label	P2 Art [CVP] ICP PA	
Scale	[20] 10-300	
Digit Format	S/D [Mean]	
Sweep Speed	12.5 [25] 50	
HR Source	[AUTO] ECG Pleth	

<b>NBP</b>		
Set Cycle Time	1 2.5 3 5 10 [15] 30 60	
<b>NBP Setup</b>		
Ready Prompt	[5] 0-10	
Inflation Limits	150 200 [280] mmHg	
<b>CO2</b>		
Scale	[6] 10 15 (% kPa) (50 80 100 mmHg)	
Unit	[%] kPa mmHg	
Sweep speed	[Fast] Slow	
MS or OFF	[MS] OFF	
<b>Recording and Printing</b>		
Parameter	Alternatives [Default selection]	User default
Waveform 1	OFF [ECG] P1 P2 FLETH	
Waveform 2	[OFF] ECG P1 P2 FLETH (* P1, ** Fleth, *** P1,)	
Waveform 3	OFF ECG P1 P2 [FLETH] (** CO2, *** CO2)	
Graphic Trend 1	[HR] P1 P2 NBP SpO2 **** Fleth CO2 Resp Temp	
Graphic Trend 2	HR P1 P2 NBP [SpO2] **** Fleth CO2 Resp Temp	
<b>Recorder Setup</b>		
Start on Alarms	YES [NO]	
Waveform Delay	[12 s] OFF	
Trend Resolution	1 [5] 10 30	
Paper Speed	6.25 12.5 [25]	
Recording Length	[30 s] Cont	
<b>Display Trends</b>		
Parameter	Alternatives [Default selection]	User default
<b>Trend Setup/ Trend Page 1</b>		
Field 1	Real-time ECG in all models	
Field 2	OFF ECG [HR] P1 P2 NBP SpO2 **** Fleth CO2 Resp Temp	
Field 3	OFF ECG HR P1 P2 [NBP] SpO2 **** Fleth CO2 Resp Temp	
Field 4	OFF ECG HR P1 P2 NBP [SpO2] **** Fleth CO2 Resp Temp	
Field 5	OFF ECG HR P1 P2 NBP SpO2 **** Fleth CO2 [Resp] Temp (** CO2, *** CO2)	
<b>Trend Setup/ Trend Page 2</b>		
Field 1	Real-time ECG in all models	
Field 2	OFF ECG [HR] P1 P2 NBP SpO2 **** Fleth CO2 Resp Temp (** SpO2)	
Field 3	OFF ECG HR P1 P2 NBP [SpO2] **** Fleth CO2 Resp Temp (* P1, ** Fleth, *** P1)	
Field 4	OFF ECG HR P1 P2 NBP SpO2 [**** Fleth] CO2 Resp Temp (* P2, ** CO2, *** P2)	
Field 5	OFF ECG HR P1 P2 NBP SpO2 **** Fleth CO2 Resp [Temp] (** Resp)	

Trend Setup/ Trend Page 3		
Field 1	Real-time ECG in all models	
Field 2	[OFF] ECG HR P1 P2 NIBP SpO2 **** Pleth CO2 Resp Temp (* HR, ** HR, *** SpO2)	
Field 3	[OFF] ECG HR P1 P2 NIBP SpO2 **** Pleth CO2 Resp Temp (* SpO2, ** SpO2, *** Pleth)	
Field 4	[OFF] ECG HR P1 P2 NIBP SpO2 **** Pleth CO2 Resp Temp (* Pleth, ** Temp, *** CO2)	
Field 5	[OFF] ECG HR P1 P2 NIBP SpO2 **** Pleth CO2 Resp Temp (* Temp, ** Resp)	

\*) default in models with invasive pressure,

\*\*) default in models with CO<sub>2</sub>,

\*\*\* ) default in models with invasive pressure and CO<sub>2</sub>

\*\*\*\* ) not available with the Nellcor option, N-LNSAT

## 10. TRENDS

The monitor accumulates and displays trend data for user selected periods between 2 and 24 hours.

There are two types of trend screens: graphic trend displays measured data in bars or dots, and numerical trends give the information in tabular form.

In addition a 10-minute trend is displayed in the **Alarm Setup** menu for every parameter with alarm limits.

During trend display, the monitor is active and the numerical information is continuously updated and displayed. Trend data is stored in memory for 15 minutes after the monitor is turned off.

## Viewing graphic trends

- Press **Menu**.
- Select **Trends**
- Select **Graph 2 h, 4 h, 12 hor 24 h**

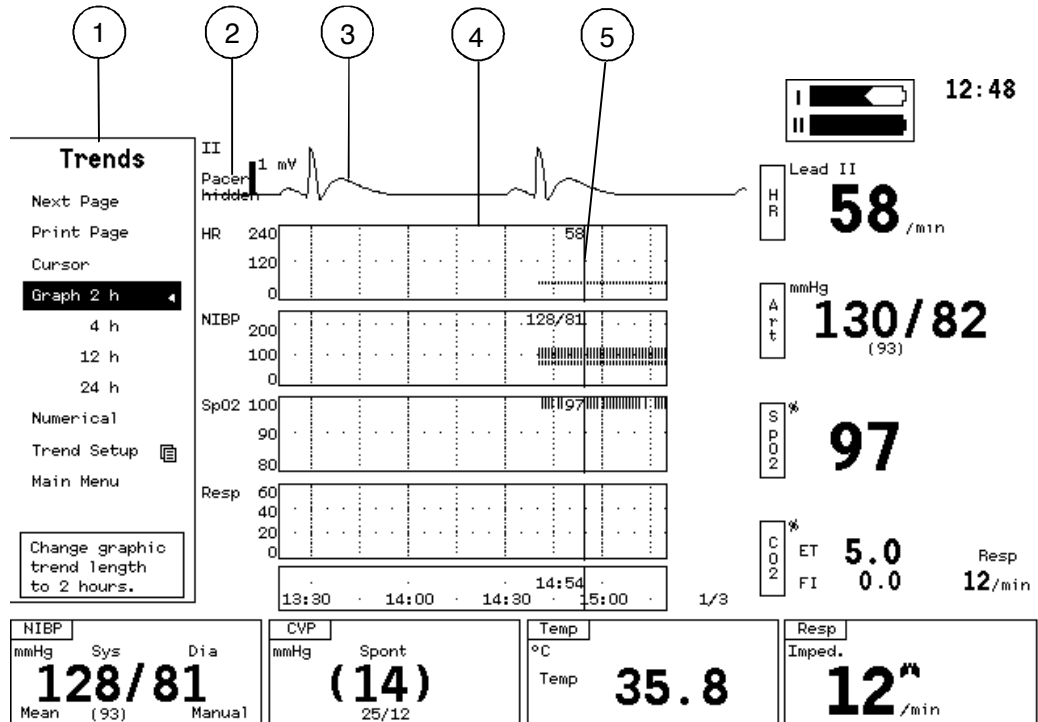

Figure 10-1 Graphic trend

- (1) List of selections
- (2) Labels
- (3) Real time ECG above the trend information
- (4) Parameter trend fields
- (5) Movable trend cursor

## Graphic trend pages

There are three pages of graphic trends. Pages are turned by selecting **Next Graph**. The page that is viewed last is stored in memory. It appears first when trends are viewed again.

**Table 10-1 The parameters trended in three pages**

<b>1st Page</b>			
<b>Basic model</b>	<b>Model with invasive pressure</b>	<b>Model with CO<sub>2</sub></b>	<b>Model with CO<sub>2</sub> and invasive pressure</b>
ECG	ECG	ECG	ECG
HR	HR	HR	HR
NBP	NBP	NBP	NBP
SpO <sub>2</sub>	SpO <sub>2</sub>	SpO <sub>2</sub>	SpO <sub>2</sub>
F <sub>resp</sub>	F <sub>resp</sub>	CO <sub>2</sub>	CO <sub>2</sub>
<b>2nd Page</b>			
<b>Basic model</b>	<b>Model with invasive pressure</b>	<b>Model with CO<sub>2</sub></b>	<b>Model with CO<sub>2</sub> and invasive pressure</b>
ECG	ECG	ECG	ECG
HR	HR	SpO <sub>2</sub>	HR
SpO <sub>2</sub>	P1	F <sub>leth</sub> *	P1
F <sub>leth</sub> *	P2	CO <sub>2</sub>	P2
Temp	Temp	F <sub>resp</sub>	Temp
<b>3rd Page</b>			
<b>Basic model</b>	<b>Model with invasive pressure</b>	<b>Model with CO<sub>2</sub></b>	<b>Model with CO<sub>2</sub> and invasive pressure</b>
ECG	ECG	ECG	ECG
Off	HR	HR	SpO <sub>2</sub>
Off	SpO <sub>2</sub>	SpO <sub>2</sub>	F <sub>leth</sub> *
Off	F <sub>leth</sub> *	Temp	CO <sub>2</sub>
Off	Temp	Off	F <sub>resp</sub>

\* ) not available with option N-LNSAT

Parameters displayed on each page can be selected in *Trend Setup*.

### Resolution

Resolution of trend display depends on the trend length selected.

**Table 10-2 Trend lengths and resolutions**

<b>Trend length (hours)</b>	<b>Resolution (minutes)</b>
2	1
4	2
12	6
24	12

## Viewing numerical trend

You may view trend data also in numerical format. The trend information is updated every five minutes and always after NIBP measurement. The latest information is displayed at the bottom of the page.

- Select **Numerical**.

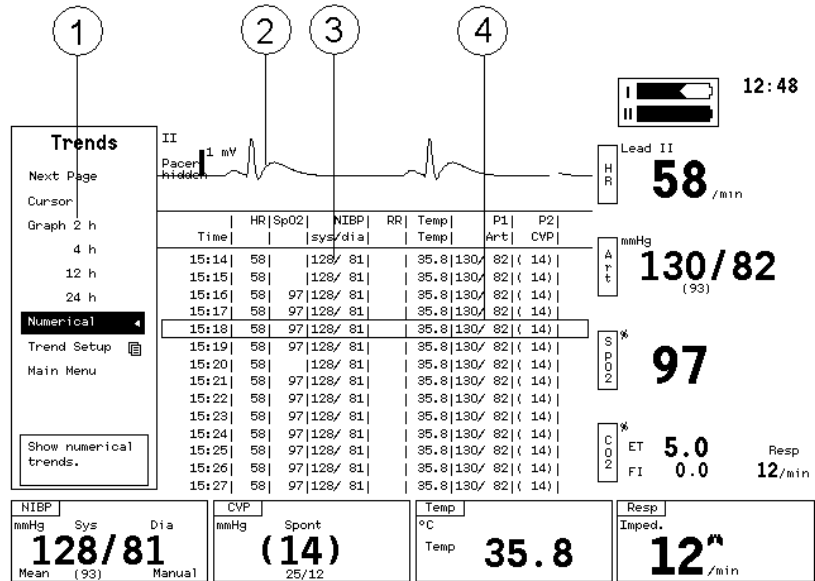

**Figure 10-2 Numerical trend page**

- (1) List of selections
- (2) Real time ECG above the trend information
- (3) Numeric trend information
- (4) Movable cursor

Parameters displayed are:

HR; SpO<sub>2</sub>; NIBP sys/dia; P1/Art sys/dia; P1/CVP mean; CO<sub>2</sub> Et/Fi; RR

## Changing trend setup

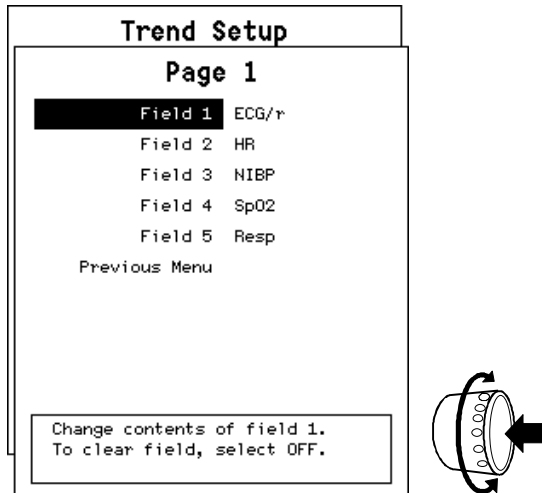

- Select **Trend Setup** in **Trends** menu.
- Select the graphic trend page you want to change.
- Select the parameter for each field, or select **OFF**.

If you want to make your trend setup permanent you can store it, see chapter "Monitor setup/ Default settings."

## Erasing trend data

- Press **Menu**.
- Go to **Patient Data**.
- Select **Reset Trends**.
- Select **YES** to confirm resetting trends.

## 11. PATIENT DATA

**Patient Data** menu is used for identifying the patient case and erasing trends and settings.

To stop a monitoring case, reset trends between patients. Alternatively you can reset all data and settings. If the trends are just being printed, they cannot be erased. A message 'Resetting not possible during printing. Please wait until printing is completed.' appears.

The **Patient Data** menu will open automatically when the monitor is started less than 15 minutes after previous case, and the trends have not been erased. This is to confirm that the collected data is connected to the right patient.

- Press **Menu**.
- Select **Patient Data**.

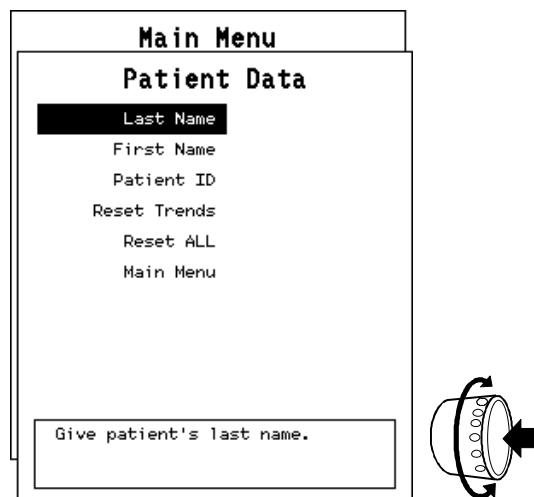

**Last Name**

Give patients last name, max 14 characters, with ComWheel.

**First Name**

Give patients first name, max 14 characters, with ComWheel.

**Patient ID**

Give patients ID, max 14 characters, with ComWheel. This starts the case, the message 'Case started' is displayed.

**Reset Trends**

Erase trend memory between patients. Select **YES** to confirm the erasing, the message 'Case ended' is displayed.

**Reset ALL**

Return all the settings to their defaults and erase trend and alarm memory. Select **YES** to confirm the erasing, the message 'Case ended' is displayed.

**Main Menu**

Return to **Main Menu**.

The **Last Name**, **First Name** and **Patient ID** can be entered also from the Datex-Ohmeda Central via network. The name is displayed as long as there are less than five alarm messages displayed simultaneously.

## 12. RECORDING AND PRINTING

The optional built-in recorder provides single, dual and triple real time waveform recording, and single and dual recordings of numerical information. In addition it can record up to 24 hours of graphic and numerical trend data.

NOTE: Printings on thermal paper may be destroyed when exposed to light, heat, alcohol etc. Take a photocopy for archives.

Graphical trend data can also be printed on the laser printer either from the local port, or, if the monitor is connected to network, using a central printer.

### Recording

- Press **Recorder Start/ Stop** to start and stop recording.

NOTE: Scaling of recorded waveforms follows the displayed parameter scaling, when applicable.

### Selecting the waveforms to be recorded

- Select up to three waveforms you wish to record in **Menu - Record/ Print - Wave Setup** menu.

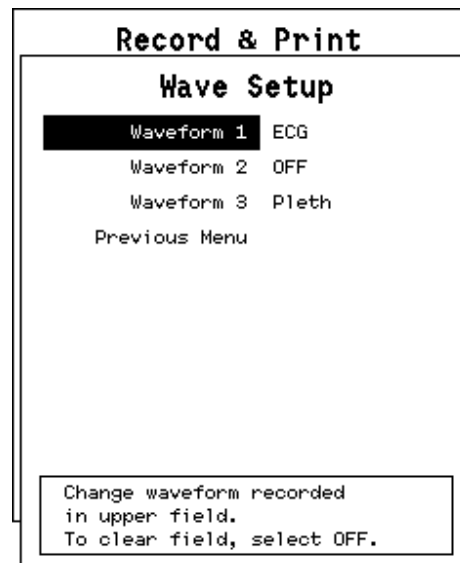

**Waveformx** Select the recorded waveforms.



## Recording trends

- Press **Menu** and select **Record/ Print**.
- Start recording by selecting **Record Graph. Trend**, or **Record Num Trend**, or **Record Tab. Trend**.
- Stop printing by selecting **Stop Graph/ Num/ Tab. Trend**.

To select the graphical trend you want to record, go to **Menu - Record/ Print - Graph - Trend Setup**.

## Other recorder settings

To make the following selections, go to **Menu - Record/ Print - Recorder Setup**.

**Start on Alarms** Select if an alarm activates the recorder or not (**YES/ NO**).

Recording time is 30 seconds: 12 seconds recording from the recorder memory, 18 seconds real time recording.

Alarm source annotated.

**Waveform Delay** Select the amount of waveform data (in seconds) that will be stored in the recorder memory and printed before real-time waveform. The choices are: **OFF** or **12 seconds**

**Paper Speed** Select the paper speed **6.25**, **12.5**, or **25** mm/ seconds.

**Recording Length**

Select the printing time, either 30 seconds or continuous.

**Previous Menu** Return to **Record&Print** menu.

## Recorder paper replacement

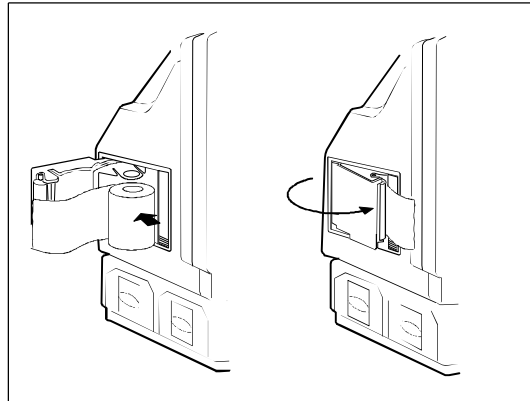

Figure 12-1 Placing paper roll

## Printing

Graphical trend pages P1, P2, and P3 can be printed either separately or all together. Print with a local laser printer, or if the monitor is connected to the network, with a central laser printer.

To print:

- Press **Menu**.
  - Select **Record/Print**.
  - Select **Print Graphical**.
  - Select **Print Graphs**
- or
- Press **Menu**.
  - Select **Trends**
  - Select **Print Page**.

### Selecting the printer

- Press **Menu**.
- Select **Record/Print**.
- Select **Print Graphical**.



- Select **Printer Location**.
- Select **Local** for local printing or an appropriate network alternative. Network printers are named in your Datex-Chmeda Central.

### Selecting the paper size

- Press **Menu**.
- Select **Record/ Print**.
- Select **Print Graphical**.
- Select **Printer Paper Size** and the right one of **A4** or **Letter** size.

### Printer installation

A laser printer can be connected to the monitor's serial connector and used as the local printer. The printer must be able to use PCL5, and a special converter cable (p/ n 894193) is required when using the parallel connection. The printers with serial connection can be connected directly to the monitor with a standard cable.

Purchase the printer locally. The printer memory should be at least 2 MB.

**WARNING** **ELECTRIC SHOCK HAZARD:** The printer must be supplied from an appropriate extra separating transformer.

**WARNING** **ELECTRIC SHOCK HAZARD:** Before starting to use the system, ensure that the entire combination complies with the international standard IEC60601-1-1 and with the requirements of the local authorities.

### Printer setup

For instructions refer to the printer's documentation. Make sure that the printer settings are set to serial interface.

## 13. NETWORK AND DATACARD

The monitor can be equipped with following options to enhance data continuum capabilities in the Datex-Ohmeda S/5 information system:

N-LNET	Network
N-LDATA	DataCard
N-LDNET	DataCard and network.

### Networking

If the monitor is connected to the network, the symbol is displayed:



#### When the monitor is connected to network

- Time and date are set by the network and cannot be adjusted in the monitor.
- The patient's name can be entered in the **Patient Data** menu to be displayed on the Datex-Ohmeda Central's and the monitor's screen and printed on the laser printouts.
- Measured and entered patient data can be viewed on the Datex-Ohmeda Central.
- Measured patient data and alarms can be viewed on other Datex-Ohmeda S/5 monitoring systems, but not vice versa.

#### Patient view and multi view on the Datex-Ohmeda Central screen

The Patient View on the Datex-Ohmeda Central screen looks like monitor's own screen.

In the Multi View, the measured values from each of the monitor shown on the screen are:

8-Patient mode	16-Patient mode
ECG waveform	ECG waveform
HR, P1, SpO <sub>2</sub> , RR or EtCO <sub>2</sub> numbers	HR numbers
Alarm field	Alarm field

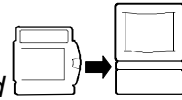

## Monitor-to-Monitor communication

When the monitor is viewed on another S/5 monitor, the following parameters are displayed:

Waveforms	ECG, Fleth, Art, CO <sub>2</sub>
Numbers	HR, SpO <sub>2</sub> , Art, CO <sub>2</sub>
1-hour numerical trend	HR, SpO <sub>2</sub> , NIBP, P1, P2, CO <sub>2</sub>

You cannot view other monitors on the S/5 Light Monitor.

## DataCard

The DataCard is a rewritable flash memory card. With the DataCard, the patient trend data collected with the S/5 Light Monitor can be transferred to other S/5 monitors with record keeping or intensive care softwares, as well as to S/5 monitors with ARK software and S/5 monitors.

Data from any card cannot be loaded to the S/5 Light Monitor, nor loaded from the network to the S/5 Light Monitor or vice versa.

## Inserting and removing the card

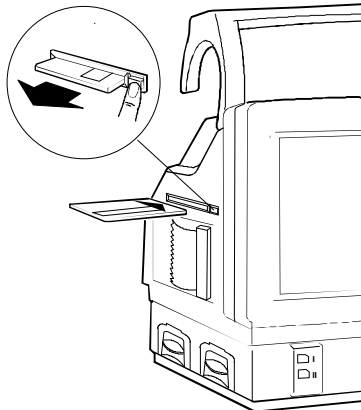

- Push the card into the slot on the left side panel of the monitor.



When the DataCard is inserted, this symbol is displayed. If the symbol is blinking, the card is not inserted properly.

If any other card or a faulty card is inserted, a message 'Faulty DataCard - change card' is displayed.

To remove the card:

- Push the lever on the side of the slot.

### **Collecting data**

When the card is inserted, the continuous patient trend data is automatically stored on it. When the card is filled, the oldest data is erased, but only if it is older than two days. You can retrieve information of approximately the last 24 hours. The memory capacity depends on the complexity of the saved data.

## 14. ECG





ECG monitoring is used to: measure the heart rate, detect arrhythmias, monitor pacemaker function, and myocardial ischaemia.

ECG reflects the electrical activity generated by the heart muscle.

You can use 5- and 3-lead sets and trunk cables, but only leads I, II, or III can be measured.

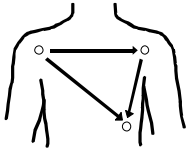
### Monitoring ECG

1.	Connect the patient cable to the blue ECG connector on the monitor's side panel.
	<p>Place the electrodes on the patient. Connect the leadwires to the electrodes.</p> <p>NOTE: Always attach all the electrodes to the patient, also when using a 5-lead cable.</p>
	The label of the lead is displayed in the ECG field and above the HR numerics.

### Applying electrodes

#### WARNING

#### PATIENT SAFETY:

Ensure proper contact of the electrosurgery return electrode to avoid possible burns on the patient via ECG electrodes and probes.

Make sure that no part of the patient connections touches any electrically conductive material, including earth.

#### Patient preparation

- Ensure good skin contact with the electrodes. Remove excessive body hair, skin oil etc.
- Check, that the pre-gelled electrodes are moist and have not dried out during storage.

## Placing electrodes

Avoid bones close to the skin, obvious layers of fat and major muscles.

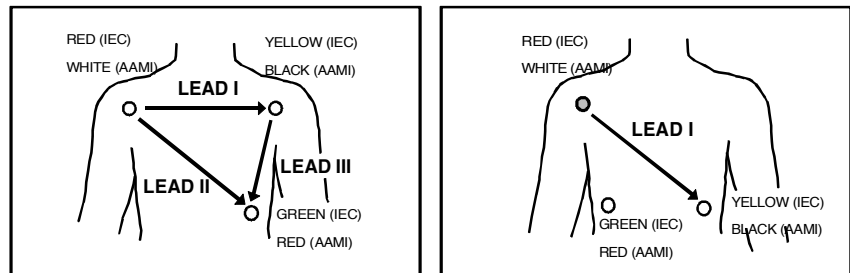

**Figure 14-1** Lead selections in typical electrode positioning

Left: Standard 3-Lead Positioning

Middle: Modified CB<sub>3</sub> 3-Lead Positioning

Right: Standard 5-Lead Positioning, place the fifth electrode in one of the six places indicated.

## Electrode coding

**Table 14-1** IEC and AAMI codes for ECG electrodes

<b>3-LEAD IEC STANDARD</b>	<b>5-LEAD IEC STANDARD</b>
L = yellow (left arm) F = green (foot) R = red (right arm)	R = red (right arm) N = black (neutral) L = yellow (left arm) F = green (foot) C = white (chest)
<b>3-LEAD AAMI STANDARD</b>	<b>5-LEAD AAMI STANDARD</b>
LA = black LL = red RA = white	FA = white FL = green LA = black LL = red V = brown

## Selecting trunk cable

Use a 5-lead set with a 5-lead trunk cable, and accordingly a 3-lead set with 3-lead trunk cable. (If you have a 3-lead set connected to a 5-lead trunk cable, you must set in the **ECG Setup** menu the selection **5 Lead Cable** to **3select**).

## What should happen when electrodes are applied ?

- ECG display appears.
- A beep is heard when a QRS complex is detected.

## Selecting ECG lead

- Press the **Menu** key and select **ECG & Resp**.
- Select **ECG Lead**.
- Select one of **I**, **II**, or **III**.

NOTE: Only 3 leads are measured, though a 5-lead set and cable are used.

NOTE: To minimize the interference from the electrosurgery unit (ESU), place the electrodes and select the lead so that the current from the surgical burning area to the return electrode does not go through the measured ECG lead.

## ECG display

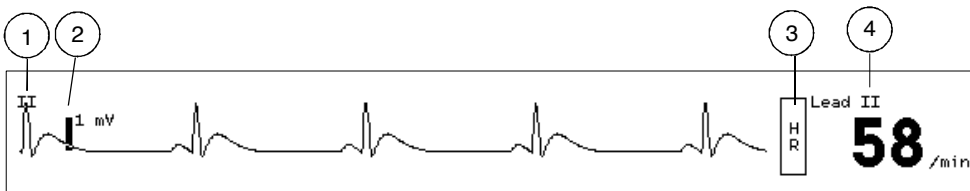

**Figure 14-2 Display of ECG and HR**

- (1) Selected lead label
- (2) 1 mV reference bar
- (3) Heart rate (HR) label
- (4) Heart rate calculation source and message field for HR messages

## Cascaded ECG

If two fields are configured (See “Monitor setup/ Waveform fields”) for ECG display the waveform continues from one field to another. Thus more QRS complexes are displayed at the same time.

## ECG adjustments

- Press the **Menu** key.
- Select **ECG & Resp**

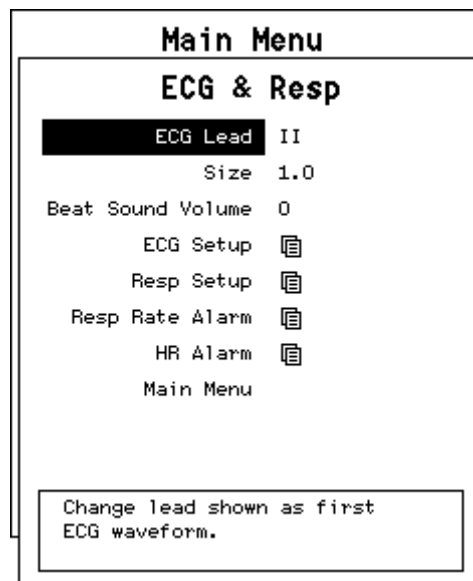

### **ECG Lead**

Select the displayed lead: *I*, *II*, or *III*.

### **Size**

Adjust from 0.2 to 5 in steps of 0.1.

The bar on the left side of the ECG display is 1 mV.

### **Beat Sound Volume**

A beat (QRS complex, or a plethysmographic or pressure pulse) produces a beep, and its volume is adjustable from 0 to 10 in steps of 1. Adjusting also changes the beat sound volume of SpO<sub>2</sub>.

(When SpO<sub>2</sub> is monitored, the tone of the pulse beep rises with increasing oxygen saturation and falls as saturation decreases.)

### **ECG Setup**

Opens a submenu for ECG settings, see below.

### **HR Alarm**

Opens a submenu for adjusting heart rate alarm, see chapter “Alarms.”

### **Resp Setup**

Opens a submenu for Respiration settings, see chapter “Respiration.”

**Resp Rate Alarm** Opens a submenu for adjusting respiration rate alarm, see chapter “Alarms.”

## ECG setup

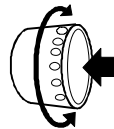
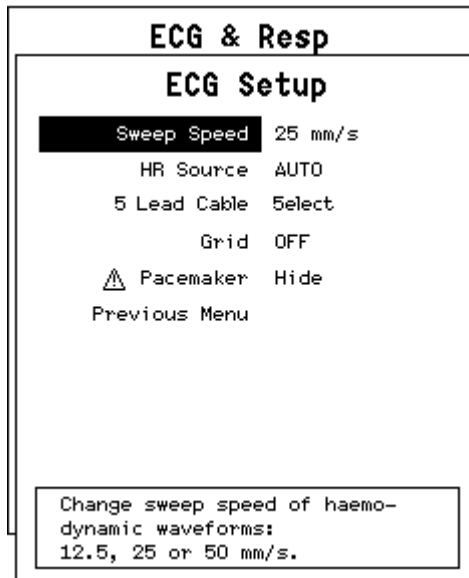

**Sweep Speed** Set the speed of the waveform sweep. Speeds are: **12.5**, **25**, and **50** mm/s on a 9" screen.

The 12.5 mm/ sec speed is suggested for monitoring patients with a slow HR to show more QRS complexes per sweep.

The 50 mm/ sec speed is recommended when monitoring patients with a high HR or when using cascaded ECG

NOTE: The sweep speed is same for ECG, plethysmographic, and invasive pressure waveforms.

**HR Source** Select the heart rate source. If ECG signal is too noisy for reliable heart rate calculation, heart rate can be calculated from pressure (**Art**) or pulse oximetry (**Pleth**). The heart rate source appears above the numerical display of the heart rate.

The **AUTO** selects the first available of ECG, Art, and Pleth.

**5 Lead Cable** If you use a 5-lead trunk cable with a 3-lead set, select **Select** on, otherwise the 'Leads Off' message will be displayed.

**Grid** Select **ON** to display ECG waveform with 0.5 mV grid lines.

**Pacemaker** Selects how to display the pacing pulse of a cardiac pacemaker, **Show**, **Hide** or **ONR**

**Hide:** The pacing pulse is filtered from the waveform.

**Show:** As above, but the pulse is marked with a constant height marker.

***ONR*** Pacing pulses are not filtered from the waveform. This improves ECG monitoring with A-V pacemaker patients, as the QRS complexes are counted even if the pacing pulse hits the complex. On the other hand, during asystole the monitor may count pacing pulses as heart rate.

## Setting heart rate alarm

Heart rate alarms can be adjusted in the ***Alarms Setup*** menu or accessed through the ***ECG & Resp.*** menu. See more detailed instructions in the “*Alarms*” chapter.

Alarm messages are explained in chapter “*Maintenance and troubleshooting, Alarm and information messages.*”

## Pacemaker patients

The monitor detects and rejects pacemaker pulses, see selection ***Pacemaker*** in the ***ECG Setup*** menu. Sometimes this may lead to unnecessary asystole alarms. The pacemaker may well change the shape of QRS so much that QRS detection may be affected.

**WARNING** **PATIENT SAFETY: Monitor may count pacemaker pulses as heart rate during cardiac arrest, some arrhythmias, or with certain types of pacemakers, particularly in *ONR* mode. Do not rely entirely upon alarms. Keep pacemaker patients under close surveillance.**

## 15. RESPIRATION



Respiration measurement uses ECG electrodes to measure the impedance changes caused by breathing.

The measurement is intended for patients three years old and up.

**WARNING** **PACEMAKER PATIENTS:** The impedance respiration measurement may cause rate changes in Minute Ventilation Rate Responsive Pacemakers. Set the pacemaker rate responsive mode off or turn off the impedance respiration measurement on the monitor.

### Monitoring respiration

Respiration measurement is activated when a digit or waveform field is selected for it:

- Press the **Menu** key.
- Select **Monitor Setup**.
- Select **Waveform Fields** or **Digit Fields**.
- Select **Resp.** to be displayed on an appropriate field.

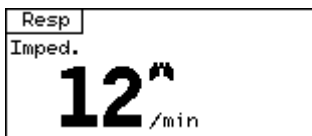

Figure 15-1 Respiration display

### Patient connections

Respiration uses the same electrodes as ECG; refer to the “ECG” section of this manual.

### Respiration setup

- Press the **Menu** key.
- Select **ECG & Resp.**

- Select **Resp Setup**.

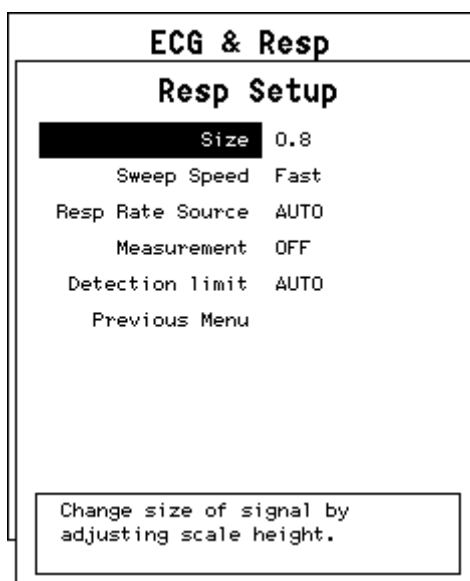

**Size** Adjust the scale height 1...50 mm/ Chm. The bar on the left displays always 1 Chm.

**Sweep Speed** Set the speed of the waveform sweep. Speeds are: **Fast** 6.25 and **Slow** 0.625 mm/ s on a 9" screen.

**Resp. Rate Source** Select the respiration rate source of **AUTO**, **CO<sub>2</sub>** and **Imped**. The **AUTO** sets the CO<sub>2</sub> first, and if it is not available, impedance respiration is used. Default selection is **AUTO**.

**Measurement** Select **ON** to measure impedance respiration and **OFF** to set the measurement off. Default selection is **ON**.

**Detection Limit** Adjusts measurement sensitivity. Selections are **AUTO**, **20%**, **40%**, **60%**, or **100%**. The percentage is the ratio to the 1 Chm reference bar which is 100%.

## Limitations of measuring

### Movement artifacts

Changing the patient position, moving the head, moving the arms or shaking will result in movement artifacts. Also the heart may cause noticeable movement, and sometimes this may interfere with the respiration measurement.

## Electrical interference

Electrical devices that emit electromagnetic disturbance will result in artifacts or disable the respiration measurement completely. Such devices are electrosurgery units and infrared heaters, among others.

## Intermittent mechanical ventilation

During spontaneous breathing the ventilator may at times support the patient's ventilation with an extra inspiration. If these ventilator inspirations are substantially larger than the spontaneous breaths, the respiration calculation may mistakenly count only the ventilator produced inspirations and expirations. You can correct this by manually adjusting the detection limits.

1. Press the **Menu** key.
2. Select **ECG & Resp**.
3. Select **Resp Setup**.
4. Select **Detection limit**.

## Measuring principle

ECG electrodes are used to measure impedance change across the thorax. Impedance change is caused by movements and changing air volume in the lungs.

Lead selection using 3-lead cables	Signal fed between electrodes	Signal measured
I	L and R	F*
II	F* and R	L
III	F* and L	R
Using 5-lead cables	L and F	N

\* ) may be neutral (N) in some older 3-lead sets.

## 16. PULSE OXIMETRY





Pulse oximetry is used for monitoring oxygen saturation ( $SpO_2$ ), pulse rate, and plethysmographic waveform.

The plethysmographic pulse waveform reflects the changes in blood pulsation at the measuring site. The amplitude of the waveform reflects the strength of perfusion, except when using the Nellcor option, N-LNSAT.

Pulse oximetry is measured with a sensor from finger, toe, ear, or with little children, from palm or feet.

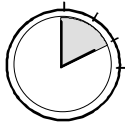
### Monitoring pulse oximetry

1.	Attach the sensor to the gray connector on the monitor's side panel.
	Attach the sensor to the patient. The $SpO_2$ and pulse rate values, and the plethysmographic pulsewave appear on the screen.
	Change the sensor site frequently.
	Remove the sensor from the patient and clean it.

## Selecting sensor

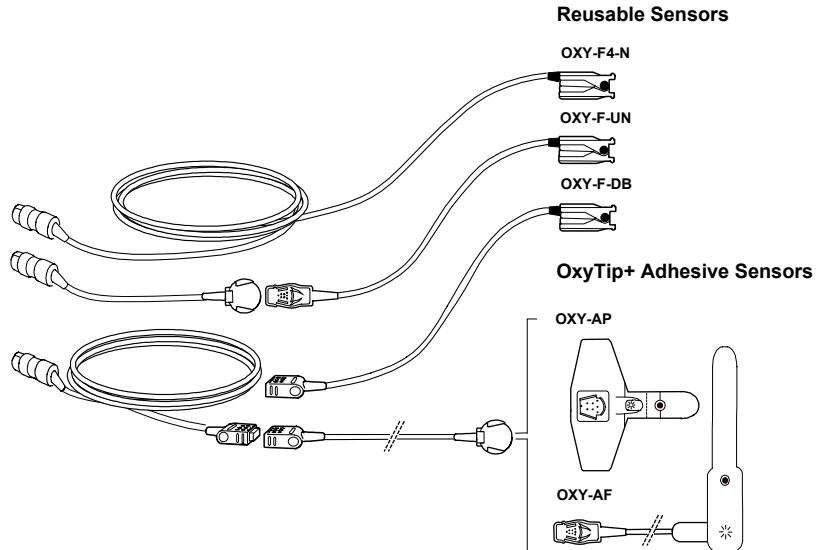

**Figure 16-1 Sat Sensors for different applications**

NOTE: These sensors cannot be used when using the Nellcor option, N-LNSAT. Please refer to chapter “Alternative SpO<sub>2</sub> measurement.”

## Applying sensors

- Use dry and clean sensors only.
- Confirm that red light lights up in the sensor when it is connected to the monitor.
- Clean the application site.  
Remove nail polish, artificial fingernail, earrings etc.  
Clip long finger nails.
- Attach the sensor cable to the wrist or bed clothes to prevent cable and sensor from moving.

**WARNING PATIENT SAFETY: Change measuring site frequently.**

- Change sensor site and check skin and circulatory status every 2-4 hours with adults, and every hour with little children.

### What should happen when sensor is applied ?

- The message 'Pulse Search' appears.
- When 'Pulse Search' is completed, the pulse rate and SpO<sub>2</sub> value will appear.
- The plethysmographic waveform will appear. The waveform scale is established according to the measured amplitude.
- Pulse beep is heard. The tone of the pulse beep will rise with increasing oxygen saturation and fall as saturation decreases.

### Pulse oximetry display

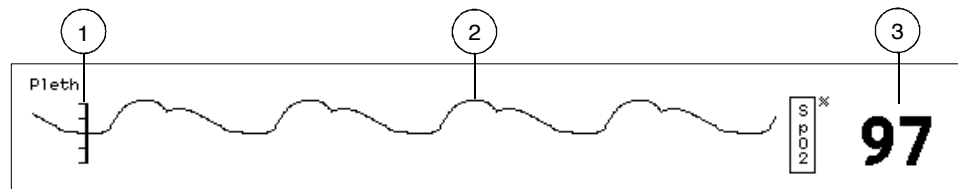

**Figure 16-2 Plethysmographic waveform with oxygen saturation number**

- (1) Bar reflecting the signal amplitude, not available with the Nellcor option, N-LSAT
- (2) Plethysmographic waveform
- (3) Oxygen saturation (SpO<sub>2</sub>)

## Measuring limitations

### Plethysmograph

The waveform is a good indicator of measurement validity. If the wave is noisy, amplitude is low, or the normal waveform cannot be seen, attach the sensor again.

### Dyshemoglobins

The pulse oximeter cannot distinguish between oxyhemoglobin and dyshemoglobins. Thus, the SpO<sub>2</sub> values may be erroneously high in smokers or in patients who have burns or carbon monoxide (CO) intoxication.

### Electrosurgery

Under some circumstances electrosurgery may cause noise on the display. Therefore, be careful in interpreting the results, especially the plethysmographic pulse waveform, during electrosurgery.

### External interference

Ambient light, intravascular dyes and vasoconstrictive drugs may affect the accuracy of the measurement. Improper sensor attachment (measuring site too thick or thin, sensor ends not aligned), or patient movement may also interfere with the measurement.

## Adjustments

- Press the **Menu** key.
- Select **SpO2 & Temp**.
- Select and adjust by turning and pressing the ComWheel.

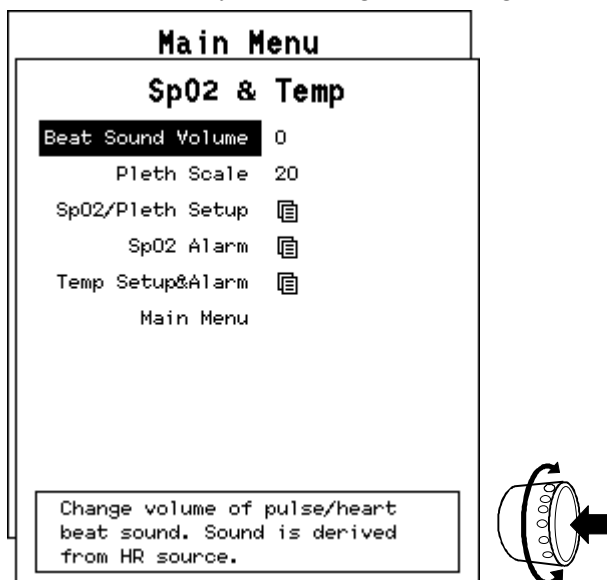

### Beat Sound Volume

Adjust beat volume from 0 to 10.

### Scale

Select Scale from **50, 20, 10, 5, 2** or use **AUTO** which automatically adjusts the scale according to the measured waveform.

NOTE: The selection is not available with the Nellcor option, N-LNSAT.

### Sweep Speed

Set the speed of the display sweep for the waveform display. The speeds are **12.5, 25, or 50** mm/ sec on a 9" screen.

NOTE: The sweep speed is same for ECG, plethysmographic, and invasive pressure waveforms.

- HR Source** Select the heart rate source. If ECG signal is too noisy for reliable heart rate calculation, heart rate can be calculated from pressure (**Art**) or pulse oximetry (**Pleth**). The heart rate source appears above the numerical display of the heart rate.
- The **AUTO** (default) selects the source in the following order: ECG, pressure, and plethysmographic pulse waveform.
- SpO<sub>2</sub> Response** Select how fast the SpO<sub>2</sub> value follows the measurement. The selections are: **Beat-to-beat**, **Normal** (10 s), or **Slow** (20 s, default setting). The selections with the Nellcor option, N-LSAT, are **Fast**, **Normal**, and **Slow**.
- SpO<sub>2</sub> Alarms** Opens a submenu for adjusting alarms, see the “*Alarms*” chapter.
- Temp Setup** Opens a submenu for adjusting temperature settings, see the “*Temperature*” chapter.
- Main Menu** Return to *Main Menu*.

## Setting SpO<sub>2</sub> alarms

The alarms can be adjusted in the **Alarms Setup** menu, accessed through the **SpO<sub>2</sub> & Temp** menu. See more detailed instructions in the chapter “*Alarms*.” Alarm messages are explained in the chapter “*Maintenance and troubleshooting; Alarm and information messages*.”

## Measuring principle

Oxygen saturation, SpO<sub>2</sub>, expressed as a percent, defines the amount of oxygen carried compared to total capacity (also called functional or *in vivo* oxygen saturation). It is measured by a two wavelength pulse oximeter.

The SpO<sub>2</sub> value is measured by light absorption technique. Red and infrared light (660 nm and 910 nm) is emitted from the light source. The amount of transmitted light is detected in the detector half. When the pulsative part of the light signal is examined, the amount of light absorbed by arterial hemoglobins is resulted, and the saturation level can be calculated.

The saturation percentage is displayed numerically, and the pulse beep sound varies according to the saturation level.

### Plethysmographic pulse wave

The plethysmographic pulse wave is derived from variations of the intensity of the transmitted light and reflects the blood pulsation at the measuring site.

### Pulse rate

Pulse rate is calculated from the plethysmographic pulse wave.

## Alternative SpO<sub>2</sub> measurement

As an alternative to the Datex-Ohmeda pulse oximetry, the monitor can be equipped with the Nellcor compatible saturation option, N-LNSAT. With this option you can use the sensors listed below.

NOTE: When the monitor has the N-LNSAT option, the monitor is equipped with the Nellcor measurement only and cannot use Datex-Ohmeda Sat Sensors.

### Plethysmographic scale

You cannot adjust the scaling when using the N-LNSAT option; it is automatically set by the monitor.

### Nellcor® sensors

Use one of the following Nellcor sensors with the N-LNSAT module:

<b>OXI SENSOR II Oxygen transducer</b>	
D-25, D-25L	Adult
D-20	Pediatric
I-20	Infant
N-25	Neonatal/ Adult
R-15	Adult Nasal
<b>OXI CLIC Oxygen transducer</b>	
A	Adult
P	Pediatric
<b>DURASENSOR Oxygen transducer</b>	
DS-100A	Adult
<b>DURA-Y Oxygen transducer</b>	
D-YS	Adult/ Pediatric/ Infant/ Neonatal
<b>OXI BAND Oxygen transducer</b>	
OX-A/ N	Adult/ Neonatal
OX-P/ I	Pediatric/ Infant

## 17. TEMPERATURE



One temperature value can be measured from various sites using YSI-400 probes, or equivalents.

### Monitoring temperature

- Attach the probe to the patient.
- Connect the temperature probe to the connector on the right side of the monitor.
- The measured value appears on the digit field.

### Temperature display

Example:

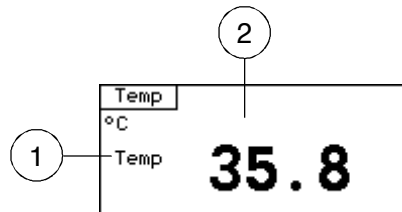

Figure 17-1 Temperature display

- (1) Label
- (2) Temperature value

### Temperature testing

The monitor automatically tests the temperature measuring function at the start-up and after that every 10 minutes. If the test fails contact your local service representative.

## Temperature setup

- Press **Menu**.
- Select **SpO2 & Temp**.
- Select **Temp Setup&Alarm**

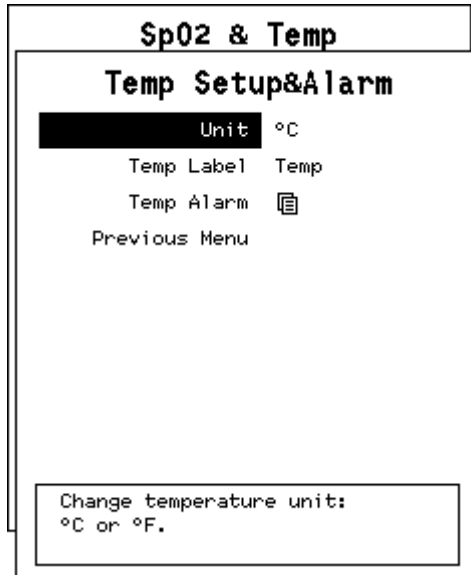

### **Unit**

Selects unit, °C or °F.

### **Temp Label**

Select the label:

<b>AirW</b>	airway temperature
<b>Axil</b>	axillary temperature
<b>Blad</b>	bladder temperature
<b>Eso</b>	esophageal temperature
<b>Myo</b>	myocardial temperature
<b>Naso</b>	nasopharyngeal temperature
<b>Rect</b>	rectal temperature
<b>Room</b>	room temperature
<b>Skin</b>	skin temperature
<b>Temp</b>	temperature
<b>Tymp</b>	tympanic temperature
<b>Core</b>	central temperature
<b>Surf</b>	surface temperature

**Previous Menu** Return to **SpO2 & Temp** menu.

## 18. NON-INVASIVE BLOOD PRESSURE (NIBP)



The monitor can measure NIBP automatically after set intervals, or take single measurements, or measure continuously for five minutes in STAT mode.

**WARNING**     **PATIENT SAFETY:** The monitor sets the inflation pressure according to the first measurement. Reset the monitor between patients to reset the inflation limit.

**CAUTION**     Vibrations during transport may disturb the NIBP measurement.

### Monitoring NIBP

- Select the appropriate cuff and hose.

Table 18-1     NIBP cuff sizes

Cuff	Color	Width		Limb circumference		Hose
		cm	inch	cm	inch	
Large adult	Red	15	6	33 - 47	13 - 18	Black
Standard adult	Blue	12	4.7	25 - 35	9 - 14	Black
Small adult	Gray	9	3.5	18 - 26	7 - 10	Black
Child	Green	6	2.4	10 - 19	4 - 7	Black
Infant	Tan	5.1	2	9 - 14	3 - 5	White
Disposable infant cuff #5		5.5	2.2	10 - 14	4 - 6	White

NOTE: Always use the white hose when measuring little children. Make also sure the **Inflation Limits** selection is set to **150** mmHg or **Auto**.

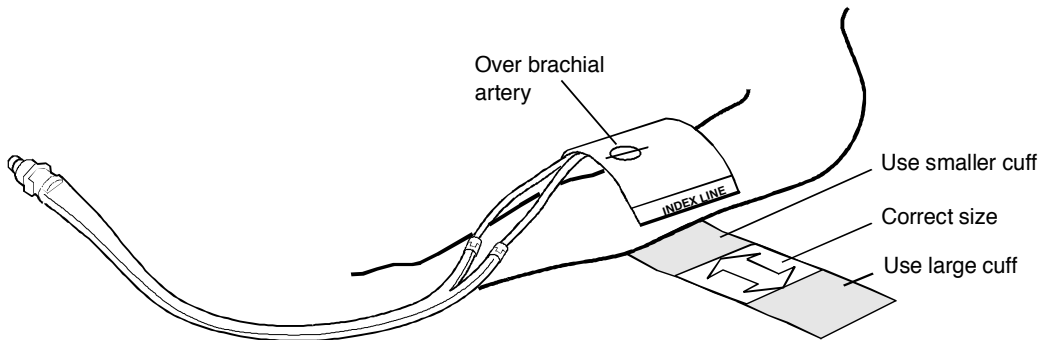
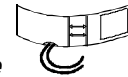

- Attach the cuff to the patient and the hose to the NIBP connector located on the right side panel of the monitor.
- Make sure that NIBP tubes are not bent, pressed or stretched. Measurement may be impaired.
- Press the **NIBP** key to open the NIBP mini menu.
- Select **Start Cycling** or **Start Manual** and press the ComWheel.
- You can also adjust the cycling time by selecting **Set Cycle Time**. Adjust the time by turning and pressing the ComWheel.
- Observe the cuffed limb frequently. The measurement may impair blood circulation.

### Display of NIBP measurement

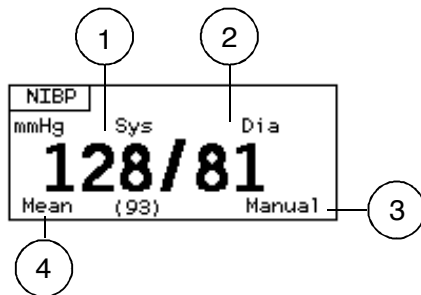

- (1) Systolic pressure
- (2) Diastolic pressure
- (3) Field shows the selected measurement (Manual, STAT), or the time since last autcycle measurement

(4) Mean pressure value of non-invasive blood pressure

At the beginning of the measurement the cuff pressure is displayed in the mean pressure value field.

If motion artifacts are detected, the monitor automatically retains deflation until the motion stops (maximum of 30 seconds). If the artifacts interrupt proper measurement, a new measurement is automatically activated.

When the measurement is ready, a short beep is heard and the result starts flashing.

### **Automatic NBP double check**

If the NBP value exceeds the alarm limits, a new measurement is taken automatically (immediately, with **MANUAL** measurements, and after 30 seconds, with **AUTO** measurements). If an alarm situation persists, an alarm signal is given out.

### **Using NBP functions**

To use NBP functions:

- Press the **NBP** key to open the NBP mini menu

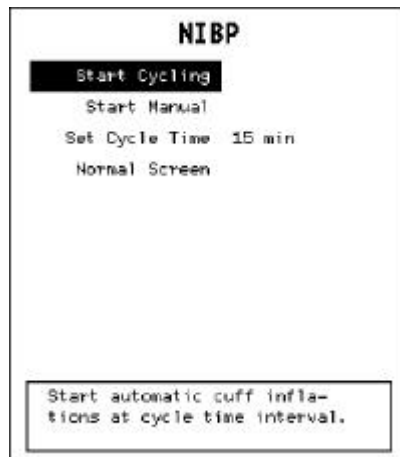

or

- Press **Menu** and select **NBP & Inv. Pres** to open the **NBP & Inv. Pressure** menu.



Starting/ Stopping Autocycle, Starting a Manual Measurement and Canceling Any Measurement are available through both menus. STAT mode and Venous Stasis are available through the **NBP & Inv. Pressure** menu only.

### Starting/ Stopping autocycle

- Select **Start Cycling/ Stop Cycling** to start/ stop automatic NIBP measurement at selected intervals.

The bar at the bottom of the NIBP display shows the time remaining to the next measurement.

Autocycling is synchronized to actual time so that if the first measurement happens at 12.02, the next measurement is done at 12.05 and again at 12.10 (5 min intervals).

### Starting a manual measurement

- Select **Start/ Stop Manual**.

### Canceling any measurement

- Press the **NBP** key,  
or
- select the corresponding menu item.

## Starting a continuous measurement (STAT)

You can start the continuous measurement for five minutes (STAT mode) through the **NBP & Inv. Pressure** menu only.

In STAT mode the early systolic value is measured and displayed until the final result is available.

After five minutes the monitor automatically returns to the previously selected cycling interval or to manual mode.

To start the measurement:

- Press the **Menu** key and select **NBP & Inv. Press**
- Select **Start STAT**.

## Using venous stasis

You can hold a constant pressure in the cuff to help venous cannulation (Venous Stasis). This function is only available through the **NBP & Inv. Pressure** menu. The pressure is maintained in the cuff for a certain time according to the inflation limits.

**Table 18-2 Inflation limits and venous stasis times**

Inflation limit	Venous stasis pressure	Venous stasis time
150 mmHg	40 mmHg	1 min
200 mmHg	60 mmHg	2 min
280 mmHg	80 mmHg	2 min

The pressurization time is displayed in the NIBP field and during the last 15 seconds the word 'STASIS' is flashed.

- Press the **Menu** key.
- Select **NBP & Inv. Press** and **Start Ven. Stasis**

To release the pressure before the time is expired:

- Press the **NBP** key.

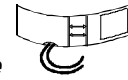

## NIBP adjustments

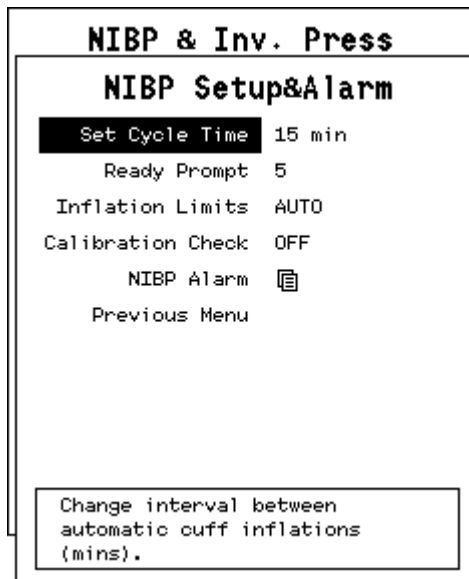

**Set Cycle Time** Select desired interval time of **1, 2.5, 3, 5, 10, 15, 30, or 60** minutes.

**Ready Prompt Vol.**

Adjust the volume of the beep that informs when the NIBP measurement is ready. The range is from 1 (soft) to 10 (loud), or 0 (OFF).

**Inflation Limits** Select the inflation pressure limit: **280, 200, or 150** mmHg.

**Calibration Check**

Start the pressure calibration check with an external manometer. See instructions below.

**NBP Alarm** Opens a submenu for adjusting the NIBP alarms, see the “Alarms” chapter.

**Previous Menu** Return to the **NBP & Inv. Pressure** menu.

## Calibration check

- Remove the cuff from the connector before entering the menu.
- Select **Calibration Check ON** in **NIBP Setup** menu.
- When the calibration menu appears, attach an external manometer with pump to the connector.
- Pump ca. 200 mmHg and compare the readings of the manometer and display. If the difference is greater than 4 mmHg, the calibration must be checked by an authorized service person.

## **NBP alarms**

NBP Alarms are set in the **Alarm Setup** menu, see the “Alarms” chapter. The alarm messages are explained in chapter “Maintenance and troubleshooting.”

## **Measuring principle**

The non-invasive blood pressure (NIBP) measurement uses the oscillometric measuring principle. The cuff is inflated with a pressure slightly higher than the presumed systolic pressure, then slowly deflated at a speed based on the patient's heart rate, collecting data from the oscillations produced by the pulsating artery. Based on this data, the unit calculates values for systolic, mean and diastolic pressures.

## 19. INVASIVE BLOOD PRESSURE



Two invasive blood pressures can be measured with the model F-LMP1.

### WARNING

#### **PATIENT SAFETY:**

**All invasive procedures involve patient risks. Use the aseptic technique. Follow catheter manufacturer's instructions.**

### WARNING

**Ensure proper contact of the return electrode of the electrosurgery unit to your patient to avoid possible burns at sensor sites.**

### WARNING

**Make sure that no part of the patient connections touches any electrically conductive material including earth.**

### WARNING

**Use only defibrillator proof transducers and cables.**

## Monitoring invasive pressures

### Preparing pressure line

- Prepare the transducer kit according to transducer manufacturer's instructions. Ensure there is no air in the line.
- Connect the kit to the transducer cable and the cable to the red connector in the monitor.
- Mount the transducer kit at heart level.
- Connect the patient catheter to the pressure line.
- Zero the transducer.
- Open the line to the patient.

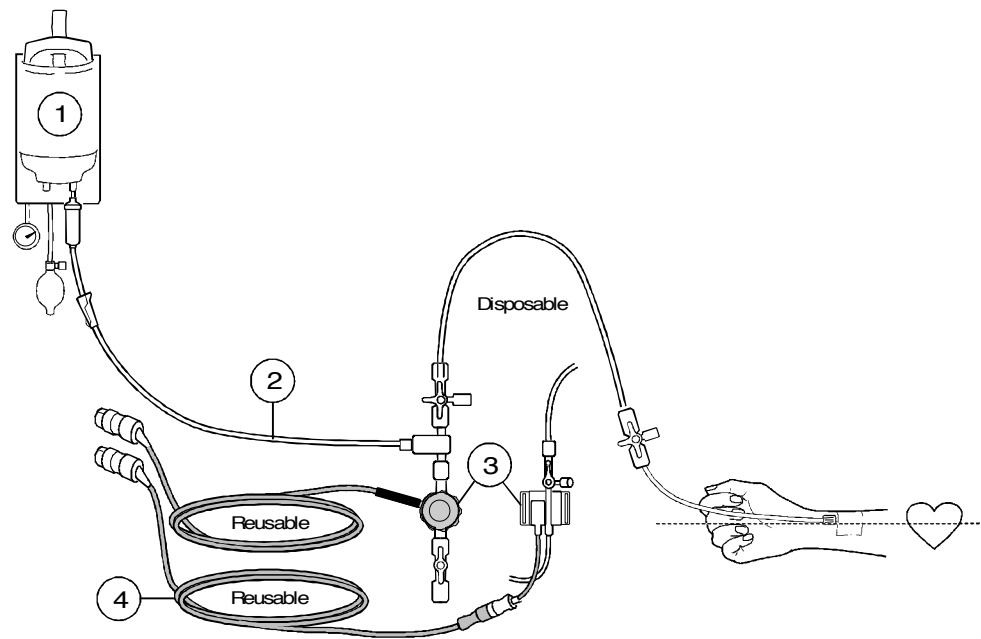

**Figure 19-1 Invasive pressure setup for disposable and reusable transducers**

- (1) Heparinized fluid bag with pressure infusor
- (2) Flushing set
- (3) Transducer
- (4) Adapter cable for using disposable transducers

### Zeroing transducer

Always zero the pressure transducer before monitoring and check zero level after power interruptions.

To zero the transducer:

- Open the transducer to air.
- Press the **Zero ALL** key,  
or  
select **Zero Px** in the **NBP & Inv. Pressure** menu.

The messages 'Zeroing' and 'Zeroed' are displayed accordingly. After the channel is zeroed, the zeroing time appears in the menu. If the zeroing fails, the previous zero is used.

- Open the transducer to the patient.

NOTE: ICP can be zeroed via the **NBP & Inv. Pressure** menu only.

**CAUTION** Mechanical shock to pressure transducer may change zero balance and calibration.

### Invasive pressure display

After the line is zeroed and opened to the patient, the pressure wave appears.

If two pressures are measured they can be combined with individual scales. (Select separate or combined waveforms in the **Monitor Setup/ Waveform Fields** menu, see chapter "Monitor setup").

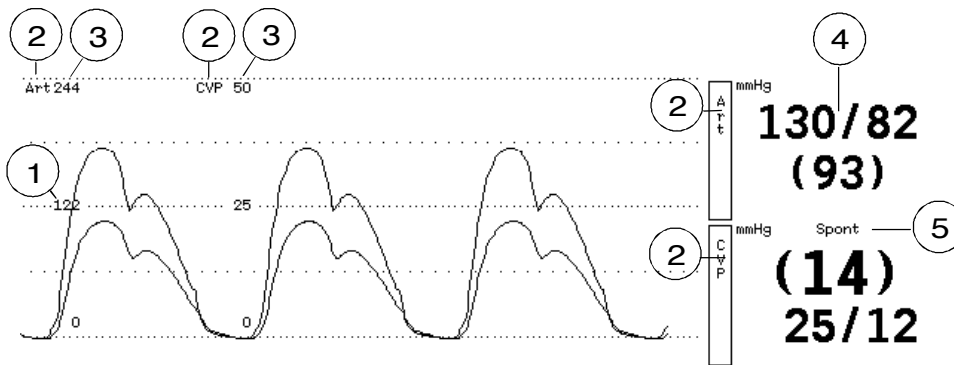
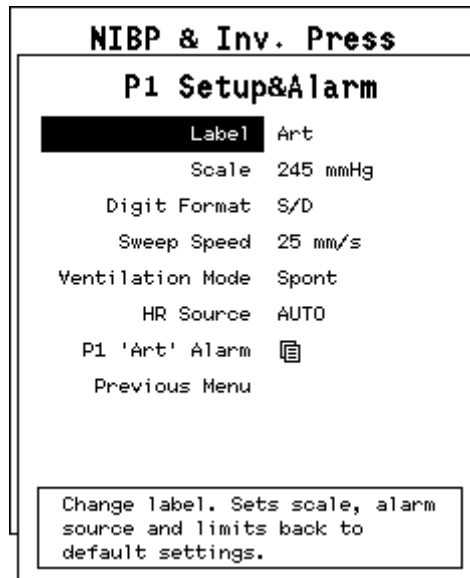

**Figure 19-2 Combined pressure waveforms**

- (1) Invasive blood pressure waveforms with zero and reference lines
- (2) Selected pressure label
- (3) Selected pressure scale
- (4) Systolic, diastolic and mean pressures
- (5) Ventilation mode selected in the **Px Setup & Alarm** menu

## Adjustments

- Press **Menu**.
- Select **NIBP&Inv. Press**
- Select **Px Setup&Alarm**



### Labeling the invasive line

The label of the pressure channel sets its scale, alarm source and alarm limits.  
The label alternatives are:

- |               |                             |
|---------------|-----------------------------|
| <b>P1, P2</b> | Standard labels             |
| <b>Art</b>    | Arterial pressure           |
| <b>CVP</b>    | Central venous pressure     |
| <b>PA</b>     | Pulmonary arterial pressure |
| <b>ICP</b>    | Intracranial pressure       |

To change the label

- Go to setup menu of the desired pressure.
- Select **Label**.
- Select the desired label from the list.

**Table 19-1 Waveform scales, alarm sources and limits that are assigned when the label is selected**

Label	P1, Art	P2, CVP	PA	ICP
Scale (mmHg)	200	20	60	20
Alarm source	sys	off	off	off
Digit format	S/D	Mean	S/D	Mean
Filter (Hz)	22	9	9	9

### Changing the scale

Scales can be adjusted between 10 and 300 mmHg in steps of 10.

- Go to setup menu of the desired pressure.
- Select **Scale**.
- Adjust the scale by turning and pressing the ComWheel.

### Other invasive pressure setup adjustments

**Digit Format** Select the displayed digit, either, systole and diastole (**S/D**) or **Mean**.

**Sweep Speed** Set the display sweep speed for the waveform display. The speeds are: **12.5**, **25**, or **50** mm/ sec.

NOTE: The sweep speed is same for ECG, plethysmographic, and invasive pressure waveforms.

#### **Ventilation Mode**

Select **Spont** or **Contrl** for spontaneous or controlled ventilation. Respiration may cause artifacts in invasive pressure measurement.

#### **HR Source**

Select the heart rate source. If the ECG signal is affected by too much noise for a reliable heart rate calculation, heart rate can be calculated from pressure (**Art**) or Plethysmographic pulse waveform (**Pleth**). The selected heart rate source is shown above the numerical display of the heart rate.

**AUTO** selects the first available of: ECG, Art, and Pleth.

#### **Px Alarm**

Opens a submenu for adjusting Alarm settings, see the “Alarms” chapter.

#### **Previous Menu**

Return to the **NBP & Inv. Pressure** menu.

## **Invasive pressure alarms**

Invasive pressure alarm is active only after pressure channel has been zeroed.

For alarm setup, see the “*Alarms*” chapter.

Alarm messages are explained in the chapter “*Maintenance and troubleshooting.*”

## **Measuring principle**

The transducer converts the pressure variations into electrical signals. The electrical signals are amplified and displayed as numeric pressure values and waveforms.

## 20. CARBON DIOXIDE, CO<sub>2</sub>

CO<sub>2</sub> can be measured with mainstream method (N-LOM option) using Mainstream CO<sub>2</sub> Sensor and airway adapter.

Respiration rate is the frequency of the peak (end tidal) CO<sub>2</sub> value per minute.

### Monitoring mainstream CO<sub>2</sub>

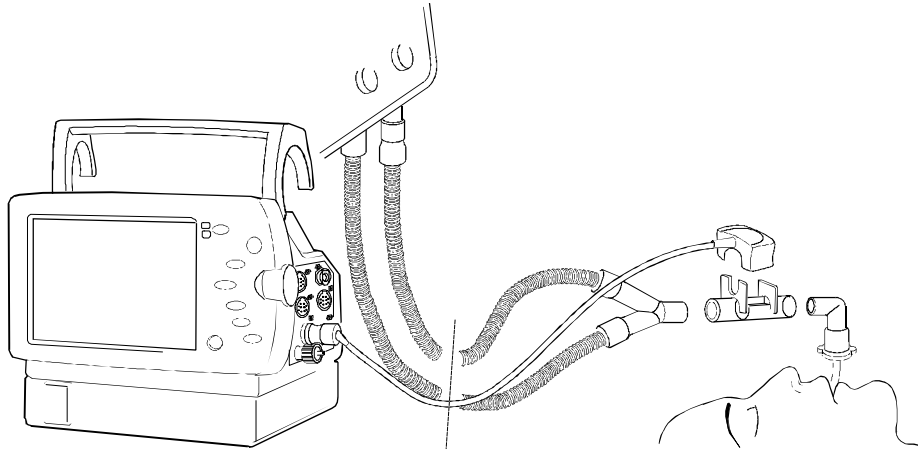

**Figure 20-1** Connecting mainstream CO<sub>2</sub> sensor

1. Connect the special airway adapter between the elbow adapter and Ypiece with the saddles upright.
2. Attach the Mainstream CO<sub>2</sub> Sensor to the adapter between the saddles so that the sensor cable fits into the slot on the farther saddle. Ensure the connection between the sensor and the adapter with the Velcro tape supplied with the sensor.

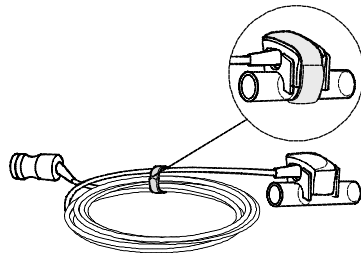

3. Connect the sensor to the connector on the monitor's side panel.  
Place the adapter as close to the patient airway as possible. Make sure that the sensor remains in upright position.

To remove the adapter:

- Detach the sensor before removing the adapter from the circuit.

**CAUTION** Do not apply force to the sensor or sensor cable.

Select the airway adapter according to the patient's status. Refer to the instructions for use provided in the adapters package.

Using the adult/ pediatric mainstream airway adapter (endotracheal diameter  $\geq$  5.5 mm) increases the dead space by 6 ml. With the low dead-space airway adapter (diameter  $<$  5.0 mm), the increase is 0.6 ml.

NOTE: Airway adapter selection recommendations should be used as a guideline. It is important for the clinician to assess each patient when selecting the appropriate airway adapter.

**WARNING** Do not allow the CO<sub>2</sub> sensor to come in contact with the patient's skin for a prolonged period of time. Mainstream sensor is heated to prevent the fogging of the airway windows.

**WARNING** Do not immerse the sensor in liquids or autoclave it.

**WARNING** Do not use damaged sensors or adapters.

**WARNING** Do not clean or sterilize a single use adapter.

## Display of CO<sub>2</sub> measurement

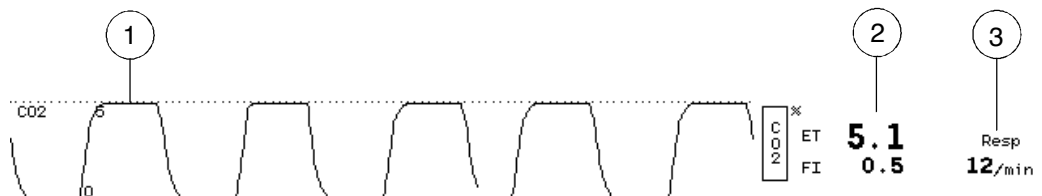

**Figure 20-2** Display of the CO<sub>2</sub> waveform

- (1) Continuous CO<sub>2</sub> waveform
- (2) Values of end tidal (ET) and fraction of inspiratory (FI) CO<sub>2</sub>
- (3) Respiration rate

## CO<sub>2</sub> adjustments

**Main Menu**

**CO<sub>2</sub>**

**Measurement Type** MainSt

Scale 6 %

N<sub>2</sub>O/O<sub>2</sub> Comp. OFF

Unit %

Sweep Speed Fast

Resp Rate Source AUTO

CO<sub>2</sub> Alarms 

Main Menu

---

Select CO<sub>2</sub> measurement:  
MainStream or OFF.

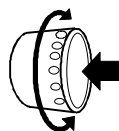

- Measurement** Set on mainstream (**MainSt**) or turn the measurement **OFF**.
- Scale** Selects 0 - 6 % 0 - 10 % 0 - 15 % or kPa and 0 - 50 mmHg, 0 - 80 mmHg, 0 - 100 mmHg. Scale 0 - 6% is used in normal situations, 0 - 10% and 0 - 15% scales are used if hypercarbia is expected.
- N<sub>2</sub>O/ O<sub>2</sub> Comp** Selects compensation: **OFF**, **N<sub>2</sub>O** or **O<sub>2</sub>**. In the breathing circuit when there is 50% or more of N<sub>2</sub>O, use N<sub>2</sub>O compensation; when there is 60% or more of O<sub>2</sub>, use O<sub>2</sub>. In other cases, turn off the compensation.
- Unit** Selects CO<sub>2</sub> unit: **%**, **kPa** or **mmHg**. See "Unit conversions" later in this chapter.
- Sweep Speed** Selects **Fast** (6.25 mm/ sec) or **Slow** speed (0.62 mm/ sec). Slow waveforms have a sweep speed one tenth of normal, for a full screen sweep (five minutes). Slow waveforms show changes better than fast waveforms.
- Resp Rate Source** Change respiration rate source: **AUTO**, **CO<sub>2</sub>** or **impedance respiration**.
- CO<sub>2</sub> Alarm** Brings you to the **Alarms Setup** menu to adjust CO<sub>2</sub> alarms.
- Main Menu** Returns you to the **Main Menu**.

## Calibration check

No routine calibration by user is required. Calibration check is recommended to be performed once a year by a qualified technical personnel. See the "Technical Reference Manual" for instructions.

## **Unit conversions**

Relationship between gas concentration and its partial pressure:

reading in mmHg = (ambient pressure mmHg \* gas concentration in %) / 100

reading in kPa = (ambient pressure in mmHg \* gas concentration in %) / 750

## **Measuring principle**

The CO<sub>2</sub> measurement is based on the infrared absorption. In the mainstream method the measurement bench is located at the patient's airway adapter.

## 21. MAINTENANCE AND TROUBLESHOOTING

**WARNING**    **ELECTRICAL SHOCK HAZARD:** Do not remove cover. Refer servicing to qualified service personnel.

### Maintenance

#### Once a month

- Clean the rear panel dust filter, see the “*Cleaning*” chapter.
- Discharge and recharge the batteries fully.

#### Once a year

- Check the CO<sub>2</sub> calibration, see “*Technical Reference Manual.*”

### Checklist

Check the following items to ensure you have remembered the essential preparations before monitoring or if any problems occur during monitoring.

If the monitor does not function as it should and troubleshooting cannot solve the problem, contact your sales representative. Qualified service personnel may use the “*Technical Reference Manual.*”

### General

Check that the

- monitor doesn't have any visual defects, such as cracks or loose parts.
- power cord with external power adapter is connected to a grounded electrical wall outlet and the voltage selector is set to local voltage.
- patient connection cables are attached to the monitor so that the color coding on the plug matches the color coding on the monitor connector.
- trends of the previous patient are erased.
- alarm limits are suitable for a new patient.

- monitor is used in correct environmental conditions, see “*General specifications.*”

### **ECG/ Respiration**

Check that the

- electrode gel is moist.
- electrodes have good skin contact.
- electrodes are positioned correctly.
- correct cable is used: 5-lead cable with 5 lead sets and 3-lead cable with 3-lead sets. (If you have a 3-lead set connected to a 5-lead trunk cable, you must set in the **ECG Setup** menu the selection **5 Lead Cable to 3elect**).
- ECG trunk cable is connected to the blue connector.
- lead wire set is properly connected to the trunk cable.
- Pacemaker selection in the **ECG Setup** menu is **Show or ONR** when a pacemaker is used.
- ECG/ Respiration is selected for display in the **Monitor Setup** menu.

For the respiration measurement:

- **PACEMAKER PATIENTS:** The impedance respiration measurement may cause rate changes in Minute Ventilation Rate Responsive Pacemakers. Set the pacemaker rate responsive mode off or turn off the impedance respiration measurement on the monitor.

### **Pulse oximetry**

Check that the

- correct SpO<sub>2</sub> sensor is selected for each patient size.
- sensor is completely dry after cleaning.
- SpO<sub>2</sub> extension cable is connected to the gray connector.
- sensor cable is properly connected to the extension cable.
- sensor is positioned correctly to the patient and the measuring site is well prepared.
- SpO<sub>2</sub> is selected for display in the **Monitor Setup** menu.

## Temperature

Check that the

- temperature probe is YSI-400 or equivalent.
- temperature probe is inserted properly into the connector.
- temperature is selected for display in the **Monitor Setup** menu.
- temperature probe is positioned correctly.

## Non-invasive blood pressure NIBP

Check that

- the O-rings on hose connectors are intact, two at monitor side.
- the NIBP hose is properly connected to the monitor and will not come loose by pulling.
- the correct NIBP cuff size is used.
- the right hose (black or white) is used for different cuffs.
- the O-ring on cuff connector is intact and the connector firmly pushed inside the cuff tube.
- there are no holes or cracks in the cuff bladder or cuff tube.
- the symbol indicating the center of the bladder is over the artery.
- all residual air is squeezed out of the cuff before wrapping it around the arm.
- the cuff is not loose.
- the cuff is at heart level.
- the tubes are not bent, pressed or stretched.
- if a leak is suspected, start venous stasis and check that the pressure is stable during stasis.
- non-invasive blood pressure is selected for display in the **Monitor Setup** menu.

## **Invasive blood pressure**

Check that

- invasive blood pressure transducer cable is connected to a red connector.
- the pressure transducer is connected to the cable.
- the patient catheter is connected to the pressure line.
- there are no air bubbles in the transducer dome or catheter line.
- the transducer is at mid heart level.
- the pressure transducer is zeroed.
- invasive blood pressure is selected for display in the **Monitor Setup** menu.

## **CO<sub>2</sub>**

Check that

- the measurement is set on.
- the sensor is properly attached to the airway adapter. Ensure the connection with the Velcro tape supplied with the CO<sub>2</sub> sensor.
- the sensor is connected to the monitor.
- a new airway adapter is used for each patient. Used adapters may leak and cause too high CO<sub>2</sub> values.

## **Batterypacks and Module**

Check that

- battery packs are properly inserted in the module.
- charging LEDs are lit when batteries are fully charged/ flashing during charging/ not lit when the monitor is battery driven.
- battery operation with a fully charged battery lasts at least one hour. If not, the battery is old and needs to be replaced.

NOTE: Discharging and recharging the battery regularly lengthens the battery lifetime.

## Alarm and information messages

### ECG

#### Alarms

Message	Explanation
Asystole	No QRS complexes in 6 sec. Asystole message is given always from ECG in spite of HR calculation source and only from ECG
HR high/ low	Measured heart rate exceeds the alarm limit.
Leads off	ECG cable, or some or all leads are off. Possibly the DC offset voltage between two electrodes is too high. 3-lead set is used with a 5-lead cable; set in <b>ECGsetup</b> menu the selection <b>5 Lead Cable</b> to <b>3elect</b> .

#### Notes

Message	Explanation
Leads off	ECG cable, or some or all leads are off. Possibly the DC offset voltage between two electrodes is too high. 3-lead set is used with a 5-lead cable; set in <b>ECGsetup</b> menu the selection <b>5 Lead Cable</b> to <b>3elect</b> .
Noise	High frequency noise, e.g. from electro-surgical unit, or 50 Hz from the mains.
Artifact?	Frequent ECG overload or dipping - Elevated baseline noise - Heart rate > 240
Casc.	Two ECG waveforms selected for display.

## **Impedance respiration**

### **Alarms**

<b>Messages</b>	<b>Explanation</b>
Apnea	No breathing detected for 20 seconds.
Resp high/ low	Measured respiration rate exceeds the alarm limit.

### **Notes**

<b>Messages</b>	<b>Explanation</b>
Leads off	Cable, or some or all the leads off. Possibly the DC offset voltage between two electrodes is too high.
Measurement off	Measurement has turned off.
Small Resp curve	Signal amplitude < 0.4 Ohm.

## **Invasive blood pressure**

### **Alarms**

<b>Messages</b>	<b>Explanation</b>
P1 (P2) High/ Low	Measured P1 (P2) exceeds the alarm limit
HR High/ Low	Measured heart rate exceeds the alarm limit.

### **Notes**

<b>Messages</b>	<b>Explanation</b>
No P1 (P2) Transducer	Transducer is not connected.
No Transducer	Transducer is not connected.
Not zeroed	Measurement on, channel is not zeroed.
Zeroing	Zeroing of P1 (P2) in progress.
Zeroed	P1 (P2) zeroed; message time-out 10 seconds.
Zeroing failed	Unsuccessful zeroing of P1 (P2). Retry.
Failed	Unsuccessful zeroing of P1 (P2). Retry.
Zero ICP via menu	ICP must be zeroed through menu.

Zero fail. Prev P1 (P2) zero valid	Zeroing failed. Previous zero value will be used.
Calibrating	Calibrating of P1 (P2) in progress.
Calibrated	P1 (P2) transducer calibrated; message time-out 10 seconds.
Calibration failed	Unsuccessful calibrating of P1 (P2).
Failed	Unsuccessful calibrating of P1 (P2).
Out of range	Measured pressure exceeds > 320mmHg or < -40 mmHg.
Zero adj >100mmHg	Offset over 100 mmHg, reduced range.

## **NBP**

### **Alarms**

#### **Messages**

#### **Explanation**

NIBP High/ Low	Measured NIBP value exceeds the alarm limit.
(NIBP) Cuff occlusion (with message beep, then caution beep)	Cuff remains pressurized after measurement or becomes pressurized during or between measurements for more than 15 seconds.
(NIBP) Cuff loose, NIBP manual (if cycling stopped)	Cuff not attached to patient or too loose. Hose not connected to the monitor. Measuring mode is changed to manual.
Air leakage (+beep)	Air leakage in cuff or hose, in one of the connectors or inside the module. Measuring mode is changed to manual.
NIBP Air leakage, NIBP manual (if cycling is stopped)	Air leakage in cuff or hose, in one of the connectors or inside the module. Measuring mode is changed to manual.

## **Notes**

<b>Messages</b>	<b>Explanation</b>
Artifacts	Unsuccessful NIBP measurement due to: <ul style="list-style-type: none"><li>- movements</li><li>- shivering</li><li>- deep breathing</li><li>- marked arrhythmia or irregular beats</li></ul>
Weak pulsation	Weak pulsation's due to: <ul style="list-style-type: none"><li>- improper cuff position</li><li>- weak or abnormal circulation</li><li>- slow heart rate associated with artifacts</li><li>- problems with measuring diastolic pressure</li><li>- small air leakage</li><li>- insufficient data to artifacts</li></ul>
Cuff overpressure	Cuff is squeezed during measurement and exceeds pressure safety limits. Measurement is canceled and safety valves are opened. Message stays 10 seconds.
Unable to measure Sys	Systolic pressure probably higher than maximum inflation pressure or artifacts in systolic area. Automatic retrial with increased pressure. Message stays 10 seconds.
Unable to measure Dia	Artifacts, accurate diastolic pressure difficult to measure. Message stays 10 seconds.
Unstable zero pressure (+beep)	Unstable zero pressure when cuff is inflated. New measurement in correct time. Measurement stays 10 seconds.
Infl. limits! Check setup (+beep)	Adult or child cuff is used, but the selected infant mode restricts the inflation pressure too low to be able to measure the blood pressure. Message stays 10 seconds.
Long measurement time (+beep)	Measurement time over two min (adult and child mode) and one min (infant mode). Message stays 10 seconds.
Wait for the measurement to be done	When measurement is going and VENOUS STASIS is attempted.
Control measurement	Pressure alarm limit is exceeded. New measurement is performed automatically to check the blood pressure. Message stays 10 seconds.

Call service. Error X (+beep)	NIBP hardware error. Contact authorized service personnel. x= error number 1-99. Message stays on the screen. See Technical Reference Manual.
-------------------------------------	---

## Temperature

### Alarms

Messages	Explanation
Temp High	Measured temperature value exceeds the alarm limit.

### Notes

Messages	Explanation
Performing temp test	During the calibration test.
Temperature error	Error message if calibration test fails.

## Pulse oximetry

### Alarms

Messages	Explanation
SpO <sub>2</sub> probe off	Sensor is not connected to the patient.
No SpO <sub>2</sub> pulse	No pulse detected during last 20 seconds or more.
Faulty probe	Damaged probe, probe is present but LEDs take no current.

### Notes

Messages	Explanation
Probe off	Sensor is not connected to the patient.
No pulse	Fleth pulses not detected.
Artifact	Interference due to movements or shivering.
Check Probe	Probably faulty sensor or wrong attachment.
Poor signal	Check the sensor site for poor blood circulation. Change site and sensor if needed.

Scale changed      Fleth scale changed automatically, 10 s time-out.

**With the Nellcor compatible option, N-LNSAT,:**

NOTE: Following messages are available also with the N-LNSAT option.

SpO <sub>2</sub> Low	SpO <sub>2</sub> ≤ alarm limit
SpO <sub>2</sub> High	SpO <sub>2</sub> ≥ alarm limit
HRLow	Pulse rate ≤ alarm limit
HRHigh	Pulse rate ≥ alarm limit
No SpO <sub>2</sub> probe	Sensor is not connected to the monitor.
No probe	Sensor is not connected to the monitor.
Pulse search	Searching for appropriate internal gain (and signal levels).
No SpO <sub>2</sub> pulse?	No pulse detected when the Fleth is selected as HR source.
SpO <sub>2</sub> probe?	No pulse detected when ECG or Art selected as HR source.

**CO<sub>2</sub>**

**Alarms**

<b>Messages</b>	<b>Explanation</b>
Resp high/ low	Measured respiration rate exceeds the alarm limit.
EtCO <sub>2</sub> high/ low	Measured EtCO <sub>2</sub> exceeds the alarm limit.
FtCO <sub>2</sub> high	Measured FtCO <sub>2</sub> exceeds the alarm limit.
Apnea	No breathing detected for 20 seconds.
No CO <sub>2</sub> Sensor	Mainstream sensor not been connected.
CO <sub>2</sub> sensor Failure	CO <sub>2</sub> sensor malfunctioning.
Unspecified CO <sub>2</sub> Sensor?	A non-Datex-Ohmeda sensor used.
Use only Datex-Ohmeda mainstream CO <sub>2</sub> Sensor	Unspecified CO <sub>2</sub> sensor detected for more than 30 seconds.
Gas module error	CO <sub>2</sub> measuring failure, contact authorized service.

Clean airway adapter	CO <sub>2</sub> sensor airway adapter foggy or dirty.
Clean or replace mainstream CO <sub>2</sub> airway adapter.	Blocked airway adapter detected > 30 s.

## Notes

Messages	Explanation
Warming	CO <sub>2</sub> sensor warming up.
O <sub>2</sub> Compensation	O <sub>2</sub> compensation selected ON.
N <sub>2</sub> O Compensation	N <sub>2</sub> O compensation selected ON.
Over Scale	Waveform is over the selected scale.
Measurement Off	CO <sub>2</sub> measurement is selected OFF.

## DataCard

### Notes

Messages	Explanation
Faulty Data Card - change card	DataCard read/ write error.
Data Card full	DataCard full of data.
Data Card inserted	DataCard is inserted in the card slot.
Data Card removed	DataCard is removed from the card slot.
Insert Data Card	DataCard is not present during case.
Faulty Data Card: change card	MenuCard or some other card is inserted in the slot.

## **Battery**

### **Alarms**

#### **Messages**

Batt Low

#### **Explanation**

**Note:** Less than 10 min of battery time available.

**Yellow Alarm:** Less than 2 min of battery time available.

### **Notes**

#### **Messages**

Batt too warm to charge

#### **Explanation**

Battery temperature > +40°C

Batt too cold to charge

Battery temperature < +10°C

## **Recorder**

### **Notes**

#### **Messages**

Recorder: out of paper

#### **Explanation**

No paper in recorder.

Recorder: cover open

Recorder cover is open.

Recorder: thermal array overheat

Thermal array is overheated, recorder does not function.

Recorder: Input voltage low

Input voltage is too low, recorder does not function.

Recorder: Input voltage high

Input voltage is too high, recorder does not work.

Recorder: System error xx

Error in recorder.

## Other messages

Messages	Explanation
Monitor temp high. Vent OK?	The temperature inside the monitor is too high. Check ventilation.
STP module error	Error in STP measurement communication.
ECGR module error	Error in ECGR measurement communication.
NIBP module error	Error in NIBP measurement communication.
CO <sub>2</sub> module error	Error in CO <sub>2</sub> measurement communication.
NSAT module error	Error in NSAT measurement communication.
Case Started	Vital signs have been detected.
Case Ended	Vital signs are not detected any longer.
RAM Error	RAM error detected.
SRAM Error	SRAM error detected.
FLASH Error	FLASH error detected.
Printing...	Printing is active.
Printer failure	Failure in printer.

## Troubleshooting

What if...	Try this:
CO <sub>2</sub> readings are unreliable.	<ul style="list-style-type: none"> <li>Check that the sensor is properly attached to the adapter. Ensure the connection with the Velcro tape supplied with the CO<sub>2</sub> sensor.</li> </ul>
ECG signal is noisy, or no QRS is detected.	<ul style="list-style-type: none"> <li>Ensure that the patient is not shivering.</li> <li>Check electrodes quality, positioning and skin contact.</li> <li>Change lead.</li> <li>Enlarge the size from 1.0 mV to 2.0 mV.</li> </ul>
Invasive blood pressure readings are unreliable.	<ul style="list-style-type: none"> <li>Make sure that there are no air bubbles in transducer system. Flush and zero.</li> <li>Place transducer on patient's mid-heart level, and zero.</li> </ul>
'Zeroing failed'-message is displayed, when the <b>Zero ALL</b> key is pressed.	<p>Stopcock not opened to room air on all channels:</p> <ul style="list-style-type: none"> <li>Zero, or continue if the lines have been zeroed separately.</li> </ul>
NBP measuring does not work or values are unreliable.	<ul style="list-style-type: none"> <li>Use cuffs of correct size and check that cuff tubings are not bent, stretched, compressed or loose.</li> <li>Prevent motion artifacts.</li> <li>Make sure that the patient is not shivering.</li> </ul>
Respiration measurement fails.	<ul style="list-style-type: none"> <li>Check electrode quality and positioning.</li> <li>Adjust the detection limits.</li> </ul>
SpO <sub>2</sub> signal is poor.	<ul style="list-style-type: none"> <li>Check sensor placement.</li> <li>Be aware of differences caused by skin pigment.</li> <li>Make sure that the patient is not shivering.</li> </ul>
Temperature measuring fails.	<ul style="list-style-type: none"> <li>Check that you have the correct kind of probe. Try another probe.</li> </ul>
The monitor does not start.	<p>The power cord is not connected:</p> <ul style="list-style-type: none"> <li>Connect the power cord to the power outlet.</li> </ul> <p>Battery empty:</p> <ul style="list-style-type: none"> <li>Replace battery with a recharged one.</li> </ul> <p>Fuses blown:</p> <ul style="list-style-type: none"> <li>Check the fuses, replace if necessary or contact your local service.</li> </ul>
Monitor is very warm.	<p>Dust filter is blocked:</p> <ul style="list-style-type: none"> <li>Clean or replace the back panel dust filter.</li> </ul>
Batteries are not recharged.	<p>Batteries are not properly inserted, power supply not connected, or monitor too warm or cold:</p> <ul style="list-style-type: none"> <li>Wait for monitor to cool down/ warm up.</li> </ul> <p>Recharge only in room temperature.</p>
Battery operation lasts less than specified.	<p>Batteries are not fully charged:</p> <ul style="list-style-type: none"> <li>Charge batteries fully, and check operation.</li> </ul> <p>Battery pack is faulty, or too old:</p> <ul style="list-style-type: none"> <li>Replace the battery pack with a new one.</li> </ul>
'Batt Low'-message.	<p>Less than 10 min of battery time left:</p> <ul style="list-style-type: none"> <li>Replace with fully charged batteries, or plug in the power cord.</li> </ul>

## 22. GENERAL SPECIFICATIONS

### Parameter specifications

#### ECG

Measured leads:	I, II or III
Frequency response:	0.5...30 Hz (-3 dB, with 50 Hz reject filter) 0.5...40 Hz (-3 dB, with 60 Hz reject filter)
Sweep speed:	12.5, 25, or 50 mm/ s

#### Heart rate/ Pulse rate

Measurement range:	30...250 bpm
Measurement accuracy:	$\pm 5\%$ or $\pm 5$ bpm whichever is greater
Display resolution:	1 bpm
Averaging time:	10 s
Display update time:	5 s
Alarms:	asystole, leads-off detection, adjustable high and low alarm limits for heart rate
Gain range:	0.2...5.0 cm/ mV
Allowable DC differential offset:	$\pm 300$ mV
Pacemaker pulse detection:	detection level: 5...500 mV, pulse duration: 0.5...2 ms

#### Impedance respiration

Measuring range:	Impedance, 0.2...6 Chm
Max. base impedance:	5 kChm
Respiration range:	4...120 resp/ min
Accuracy:	$\pm 5\%$ or $\pm 5$ resp/ min whichever is greater

Averaging:	30 s
Update interval:	10 s
Display resolution:	1 resp/ min
Sweep speed (trace):	slow 0.62 mm/ s, fast 6.25 mm/ s
Alarms:	apnea, adjustable high and low alarm limits for respiration rate
Gain range:	0.1...5 cm/ Chm

### **Pulse oximetry(SpO<sub>2</sub>)/ Pleth**

Measurement method:	red and infrared light absorption SpO <sub>2</sub>
Measurement range:	40...100 %
Calibration range:	50...100 %; calibrated against functional oxygen saturation
- with N-LSAT:	70...100 %; calibrated against functional oxygen saturation
Display resolution:	1 digit (1 % of SpO <sub>2</sub> )
Measurement accuracy <sup>†</sup> :	100...80 % ± 2 digits (± 1 SD) 80...50 % ± 3 digits (± 1 SD) 50...40 % unspecified
- with N-LSAT <sup>**</sup> :	100...70 % ± 2 digits (± 1 SD) for sensor types D-25/ D-25L, N-25, D-20, I-20 100...70 % ± 2,5 digits (± 1 SD) for sensor OXCLIQ, OXCLIQP 100...70 % ± 3 digits (± 1 SD) for sensor types D-YS, DS-100A, OX-A/ N, OX-P/ I 100...70 % ± 3,5 digits (± 1 SD) for sensor type R-15 70...40 % unspecified
Display averaging time:	adjustable 20 s, 10 s, or beat-to-beat
- with N-LSAT:	adjustable slow, normal or fast
Alarms:	probe off, no probe, no pulse, adjustable high and low, alarm limits for SpO <sub>2</sub>

### **Pulse rate**

Measurement range:	30...250 bpm
Display resolution:	1 digit (1 bpm)
Measurement accuracy:	$\pm 5\%$ or $\pm 5$ bpm
- with N-LNSAT:	$\pm 3$ bpm
Alarms:	adjustable high and low alarm limits for pulse rate

#### **Plethysmographic pulse waveform**

Scales:	proportional scaling: 2, 5, 10, 20, 50 mod % or automatic scaling
- with N-LNSAT:	automatically scaled by the measurement board, the actual scale unknown.

<sup>\*)</sup> Accuracy is based on deep hypoxia studies using Datex-Ohmeda Finger Sensors on volunteered subjects. Arterial blood samples have been analyzed by a Radiometer OSM Co-oximeter. Refer to Datex-Ohmeda Sat Sensor directions for specific SpO<sub>2</sub> accuracy.

<sup>\*\*)</sup> Option N-LNSAT: Accuracy specifications are based on testing the monitor and sensor on healthy adult volunteers in induced hypoxia studies.

#### **Temperature**

Measurement units:	$^{\circ}\text{C}$ or $^{\circ}\text{F}$
Measurement range:	10...45 $^{\circ}\text{C}$ (50...113 $^{\circ}\text{F}$ )
Measurement resolution:	0.1 $^{\circ}\text{C}$ (0.1 $^{\circ}\text{F}$ )
Measurement accuracy:	$\pm 0.1$ $^{\circ}\text{C}$ (25...45.0 $^{\circ}\text{C}$ ) $\pm 0.2$ $^{\circ}\text{C}$ (10...24.9 $^{\circ}\text{C}$ )
Probe type:	Compatible with YSI 400 series

#### **Non-invasive blood pressure**

Measurement principle:	oscillometric with linear deflation
Deflation speed:	heart rate dependent, 5...13 mmHg/ s
Measurement range:	adult 25...260 mmHg child 25...190 mmHg infant 15...140 mmHg
Pulse rate range:	30...250 bpm

Numeric display:	systolic, diastolic and mean arterial pressure		
Alarms:	cuff loose, cuff occlusion, adjustable high and low alarm limits for systolic, diastolic, mean or off		
Typical measurement time:	adult 23 s and infant 20 s		
<b>Safety features:</b>	<b>adult</b>	<b>child</b>	<b>infant</b>
Initial inflation pressure (mmHg):	185	150	120
Max. inflation pressure (mmHg):	280	200	150
Overpressure limit (max. 2 s; mmHg):	320	220	165
Max. inflation time (>13 mmHg, min):	2	2	1
Safety valve (mmHg):	320	220	165

**Invasive blood pressure (F-LMP1 models only)**

Measurement range:	-40...320 mmHg
Measurement accuracy:	± 5 % or ± 2 mmHg
Numeric display	
Range:	40...320 mmHg
Resolution:	1 mmHg
Averaging:	over 5 s or end-expiratory filtering
Display update:	every 5 s
Alarms:	adjustable high and low alarm limits for systolic, diastolic and mean pressures, or off

**Waveform display**

Range:	-30...300 mmHg
Scales:	adjustable in 10 mmHg increments

**Pulse rate**

Measurement range:	30...250 bpm
Resolution:	1 bpm

Resolution:	1 bpm
Accuracy:	± 5 % or 5 bpm
Transducer sensitivity:	5 µV/V mmHg, 5 Vdc, max.20 mA
Pressure filter:	22 Hz (-3 dB) for P1, Art 9 Hz (-3dB) for P2, CVP, PA, ICP

### CO<sub>2</sub> (option N-LCM)

Principle of operation:	Non-dispersive infrared, single beam, single frequency, fully chopped, ratiometric
Measurement range:	0-99 mmHg / 0-13 vol-% / 0-13 kPa
Accuracy <sup>**</sup> )	0-40 mmHg / 0-5.3 vol-% ± 2 mmHg / ±0.3 vol-% 41-76 mmHg / 5.3-10 % ± 5 % of reading 77-99 mmHg / 10-13 % ± 10 % of reading
Respiration rate measurement range:	4-150 breaths/ minute
Pressure compensation:	automatic, continuous
Gas compensations:	User selectable O <sub>2</sub> , N <sub>2</sub> O or OFF
Calibration:	No routine calibration required; automatic self-calibration every 30 ms
Alarms:	adjustable high and low alarm limits for Et/ Fi CO <sub>2</sub> and respiration rate
CO <sub>2</sub> sensor weight:	< 18,5 g (excluding cable)
Cable length:	3 meters
Warm-up time:	< 80 seconds from 25 ° C / 77 ° F
Response time:	100 ms

\*\* ) typical value in conditions 22,5° C, 760 mmHg, CO<sub>2</sub> in balance air, I:E 1:2

### General

Monitor (WxDxH):	325 x 160 x 210 mm / 12.8 x 6.3 x 8.3"
Battery module (WxDxH):	290 x 150 x 40 mm / 11.4 x 5.9 x 1.6"
Weight:	4.2 kg / 9.3 lb.
Weight w/ battery:	6.1 kg / 13.5 lb.

Input voltage:	12.5 VDC
Power consumption	17.5 ... 37 W depending on the options used
Safety standards:	Designed to meet IEC60601-1, CANV CSAC22.2 No. 601.1-M90 and UL2601-1, CE-marking according to Directive 93/42/EEC
Output specifications:	RS-232 computer serial output Defibrillation synchronization signal (According to ANSI/AAMI EC13-1992. Time interval from Rpeak to sync pulse output $\leq$ 35 ms.) Nurse Call Analog output, 2 fixed and 2 freely configurable outputs
Printing:	Local printing with laser printer (PCL5), or via network.
Recorder option:	Built-in three channel thermal array recorder.

### **Environmental conditions**

Operating temperature:	0...40 °C (32...104 °F), CO <sub>2</sub> and Nellcor options +5...40 °C (41...104 °F) mainstream sensor +10...40 °C (50...104 °F) Nellcor measurement optimal temp. +28...40 °C (82...104 °F) Battery charging temperature 10...40 °C (50...104 °F)
Storage temperature:	-30...70 °C (-22...158 °F), -20...60 °C (-4...140 °F) with CO <sub>2</sub> -30...50 °C (-22...122 °F) for batteries
Relative humidity:	5...95 % non-condensing
Mechanical shock	50g, 11 ms

For accessories, please refer to the Datex-Ohmeda Patient Monitor supplies and accessories catalogue.

Specifications subject to change without notice.

### **Display**

Display size and type:	9" monochrome EL display
Number of traces:	Up to 4
Display resolution:	640 x 400
Display layout:	User-configurable

Integrated direct function keys, menu key and ComWheel™ for selections and adjustments in menus.

## Trends

Graphical:	2, 4, 12 and 24 h
Numerical:	all parameters, sampled every 5 min and after NIBP measurement
Trend cursor:	both in graphical and numerical trends

## Alarms

- Adjustable high and low alarms for HR, Resp, NIBP, SpO<sub>2</sub> Temp, CO<sub>2</sub> (Et/ Fi) and Invasive Pressures Alarm system classified according to priority; visually with color and audio tone coded.
- Central alarm display and adjustment page.
- 10 min graphical mini trends referenced to set alarm limits.
- Automatic alarm limits function; alarm limits automatically calculated from current parameter reading when selected.
- Alarms history displaying 10 latest alarms.

## Light Monitor Battery Module (optional) (w/ 2 battery slots)

Type:	NiCd battery
Capacity:	Up to 2 hours (1 h/ batt) typical on full charge at 23 °C/ 73 °F
Recharging:	When connected to line power or DC (N-LPCW or N-LPCWT)
Charging time:	3.5 h / battery to full capacity

## S/ 5 Light Monitor Backup Battery (optional)

Type:	NiCd battery
Capacity:	Up to 30 min typical on full charge at 23 °C/ 73 °F
Recharging:	When connected to line power or DC (N-LPCW or N-LPCWT).
Charging time:	1.5 h / battery to full capacity

## **External Power Adapter**

### **N-LPOW**

AC voltage range:	220-240 V/ 100-120 V~ 50/ 60 Hz
Allowed AC voltage fluctuations:	100 V-10 %..120 V+10 %, 220 V-10 %..240 V+10 %
DC output voltage:	12.5 V and 18.5 V
Protection class:	Class I
Grounding:	Hospital grade

## **Power Adapter for transport vehicles (optional)**

### **N-LPOWT**

Input voltage range and fluctuations:	12 Vdc -15 %..32 Vdc +10 %
Output voltage:	12.5 Vdc and 18.5 Vdc

## **Option codes**

<b>Description</b>	<b>Order code</b>
S/5 Light Monitor	F-LM1 w/ ECG, Resp, NIBP, SpO <sub>2</sub> , Temp
S/5 Light Monitor	F-LMP1 w/ ECG, Resp, NIBP, SpO <sub>2</sub> , Temp, 2xIBP
Light Monitor Power Adapter	N-LPOW Power adapter, 110/ 220 V
Light Monitor Transport Power Adapter	N-LPOWT Transport power adapter, 12-32 V
Light Monitor Battery Module	F-LBAT Battery module w/ two batteries
Light Monitor Recorder	N-LREC Built-in 3-channel thermal array recorder
S/5 Light Monitor CO <sub>2</sub> Option	N-LCOM Mainstream CO <sub>2</sub>
Mainstream CO <sub>2</sub> sensor	902300
DataCard Option	N-LDATA
Network Option	N-LNET
DataCard & Network Option	N-LDNET
Nellcor SpO <sub>2</sub> Option	N-LNSAT
External Battery Charger w/ two batteries	N-LCHGR

### **Nurse call and defibrillator synchronization signals**

The nurse call signal is generated when the alarm is activated. Alarm silencing suppresses the nurse call signal.

The defibrillator synchronization digital signal is generated by ECG. The pulse will be given on each rising R-wave edge on QRS-complex. The pulse amplitude is 5 V and width is 10 ms. When the def sync signal is active, the signal is set to state 1. After 10 ms the state is set to 0. A new pulse will not be generated before the previous pulse is deactivated.

**WARNING PATIENT SAFETY:**  
**Use only cables with shielding against electromagnetic interference.**

**WARNING** Do not use delayed analog signals for defibrillator and intra-aortic balloon pump synchronization.



## 23. ACCESSORIES

**CAUTION** Use only cables and accessories approved by Datex-Ohmeda. Other cables and accessories may damage the system or interfere with measurement.

For further information on the accessories listed below, see the catalogue "Datex-Ohmeda Patient Monitor Supplies and Accessories."

### GAS MONITORING

#### Mainstream CO<sub>2</sub> accessories

Product name	Order code	Specification	Note
Mainstream CO <sub>2</sub> sensor	902300	Mainstream CO <sub>2</sub> sensor	Use with S/ 5 Light Monitor (F-LM1, F-LMP1)
Mainstream CO <sub>2</sub> airway adapter	902301 pkg of 10 pcs	Single use mainstream CO <sub>2</sub> airway adapter, adult/ pediatric Dead space: 6 ml Connectors: 15F-15M Maximum flow: 120 l/ min.	Use with S/ 5 Light Monitor (F-LM1, F-LMP1)
Mainstream CO <sub>2</sub> airway adapter	902302 pkg of 10 pcs	Single use mainstream CO <sub>2</sub> airway adapter, low dead space Dead space: <1 ml Connectors: 15F-15M Maximum flow: 30 l/ min.	Use with S/ 5 Light Monitor (F-LM1, F-LMP1)
Mainstream CO <sub>2</sub> airway adapter	902304 pkg of 3 pcs	Reusable mainstream CO <sub>2</sub> airway adapter, adult/ pediatric Dead space: 6 ml Connectors: 15F-15M Maximum flow: 120 l/ min.	Use with S/ 5 Light Monitor (F-LM1, F-LMP1)

#### Calibration gases

Product name	Order code	Specification	Note
Calibration gas regulator	755533	Regulator for QUICKCAL calibration gas cans	Use with calibration gas, aerosol cans: 755580 755581 755582 755583
QUICKCAL calibration gas	755580 pkg of 4 cans	QUICKCAL calibration gas, aerosol can	Use with regulator 755533

		Contains: 5.0%CO <sub>2</sub> Balance air Accuracy: 0.5%relative	
Calibration Check Adapter Kit	902305	CO <sub>2</sub> Calibration Check Adapter and silicon tube	For 755580
Y-fitting for gas regulator	733831	Y-fitting for calibration gas regulator	For 755533 and 755530

## **PULSE OXIMETRY SENSORS**

### **Sat Sensors, reusable**

<b>Product name</b>	<b>Order code</b>	<b>Specification</b>	<b>Note</b>
FingerSat Sensor	SAS-F4	Cable 4 m/ 13 ft	Standard sensor for adults and children. Recommended use: short term monitoring, OR
FingerSat Sensor	SAS-F	Cable 1.3 m/ 4 ft	Standard sensor for adults and children. Recommended use: short term monitoring, OR Requires Sat Sensor Cable.
FlexSat Sensor	SAS-W	Cable 1 m/ 3 ft, includes cloth wrap.	Multisite sensor for adults and infants. Recommended use: long term monitoring, ICU and PACU. Requires Sat Sensor Cable.
EarSat Sensor	SAS-E	Cable 1 m/ 3 ft	Multisite sensor for adults and infants. Recommended use: short term monitoring, PACU. Requires Sat Sensor Cable.

### **Sat Sensors, single patient**

<b>Product name</b>	<b>Order code</b>	<b>Specification</b>	<b>Note</b>
Single patient Sat Sensor	16580 pkg of 12 pcs	Infant, cable 0.7 m/ 2 ft	Recommended use: long term monitoring, ICU. Requires Sat Sensor Cable.
Single patient Sat Sensor	16581 pkg of 12 pcs	Pediatric, cable 0.7 m/ 2 ft	Recommended use: long term monitoring, ICU. Requires Sat Sensor Cable.
Single patient Sat Sensor	16582 pkg of 12 pcs	Adult, cable 0.7 m/ 2 ft	Recommended use: long term monitoring, ICU. Requires Sat Sensor Cable.

**Sat Sensor cables**

Product name	Order code	Specification	Note
Sat Sensor Cable	SAS-C1	Cable 1.5 m/ 5 ft	Use only with Datex-Chmeda Sat Sensors.
	SAS-C3	Cable 3.0 m/ 10 ft	Use only with Datex-Chmeda Sat Sensors.
Sat Sensor Cable	SAS-C10	Cable 10 m/ 33 ft	Use only with Datex-Chmeda Sat Sensors.

**Clips, wraps and tapes**

Product name	Order code	Specification	Note
Bed sheet clip	891192 pkg of 3 pcs	Bed sheet clip	
Cloth wrap	731040 pkg of 25 pcs	Cloth wrap	Use with FlexSat and Flexalite Sensors.
Preparation tape	875282 pkg of 12 pcs	Preparation tape for ear application	Use with FlexSat and Flexalite Sensors.

**ECG CABLES**

NOTE: All Datex-Chmeda ECG cables can be used for respiration monitoring with Datex-Chmeda S/ 5 monitors.

**ECG trunk cables, IEC color coding**

Product name	Order code	Specification	Note
300-Series 3-lead trunk cable, IEC	545305	300-Series 3-lead trunk cable 1.2 m/ 4 ft, IEC color coding	Requires 300-Series lead set with IEC color coding.
	545300	300-Series 3-lead trunk cable 3.0 m/ 10 ft, IEC color coding	Requires 300-Series lead set with IEC color coding.
	545304	300-Series 3-lead trunk cable 5.0 m/ 16 ft, IEC color coding	Requires 300-Series lead set with IEC color coding.
300-Series 5-lead trunk cable, IEC	545306	300-Series 5-lead trunk cable 1.2 m/ 4 ft, IEC color coding	Requires 300-Series lead set with IEC color coding.
300-Series 5-lead trunk	545301	300-Series 5-lead trunk	Requires 300-Series lead set

cable, IEC		cable 3.0 m/ 10 ft, IEC color coding	with IEC color coding.
------------	--	--------------------------------------	------------------------

### ECG lead sets, IEC color coding

Product name	Order code	Specification	Note
300-Series 3-lead set, IEC	545315	300-Series 3-lead set with clips, 75 cm/ 30 in, IEC color coding	Detachable leads. Requires 300-Series trunk cable with IEC color coding.
300-Series 5-lead set, IEC	545316	300-Series 5-lead set with clips, 125 cm/ 49 in (leg) and 75 cm/ 30 in (chest), IEC color coding	Detachable leads. Requires 300-Series trunk cable with IEC color coding.

### ECG trunk cables, AAMI color coding

Product name	Order code	Specification	Note
300-Series 3-lead trunk cable, AAMI	545307	300-Series 3-lead trunk cable 1.2 m/ 4 ft, AAMI color coding	Requires 300-Series lead set with AAMI color coding.
	545302	300-Series 3-lead trunk cable 3.0 m/ 10 ft, AAMI color coding	Requires 300-Series lead set with AAMI color coding.
300-Series 5-lead trunk cable, AAMI	545308	300-Series 5-lead trunk cable 1.2 m/ 4 ft, AAMI color coding	Requires 300-Series lead set with AAMI color coding.
300-Series 5-lead trunk cable, AAMI	545303	300-Series 5-lead trunk cable 3.0 m/ 10 ft, AAMI color coding	Requires 300-Series lead set with AAMI color coding.

### ECG lead sets, AAMI color coding

Product name	Order code	Specification	Note
300-Series 3-lead set, AAMI	545317	300-Series 3-lead set with clips, 75 cm/ 30 in, AAMI color coding	Detachable leads. Requires 300-Series trunk cable with AAMI color coding.
300-Series 5-lead set, AAMI	545318	300-Series 5-lead set with clips, 125 cm/ 49 in (leg) and 75 cm/ 30 in (chest), AAMI color coding	Detachable leads. Requires 300-Series trunk cable with AAMI color coding.
300-Series 3-lead set, AAMI	545327	300-Series 3-lead set with snaps, 75 cm/ 30 in, AAMI color coding	Detachable leads. Requires 300-Series trunk cable with AAMI color coding.
300-Series 5-lead	545328	300-Series 5-lead set with snaps,	Detachable leads.

set, AAMI		125 cm/ 49 in (leg) and 75 cm/ 30 in (chest), AAMI color coding	Requires 300-Series trunk cable with AAMI color coding.
-----------	--	---	---

### ECG replacement clip leads

Product name	Order code	Specification	Note
300-Series replacement clip lead	545340	300-Series replacement clip lead, red R, 75 cm/ 30 in	
	545341	300-Series replacement clip lead, green F, 75 cm/ 30 in	
	545342	300-Series replacement clip lead, yellow L, 75 cm/ 30 in	
	545343	300-Series replacement clip lead, white C, 75 cm/ 30 in	
	545344	300-Series replacement clip lead, black LA, 75 cm/ 30 in	
	545345	300-Series replacement clip lead, brown V, 75 cm/ 30 in	
	545358	300-Series replacement clip lead, red LL, 75 cm/ 30 in	

Product name	Order code	Specification	Note
300-Series replacement clip lead	545359	300-Series replacement clip lead, white RA, 75 cm/ 30 in	
	545346	300-Series replacement clip lead, red LL, 125 cm/ 49 in	
	545347	300-Series replacement clip lead, green F, 125 cm/ 49 in	
	545348	300-Series replacement clip lead, black N, 125 cm/ 49 in	
	545349	300-Series replacement clip lead, green FL, 125 cm/ 49 in	

### ECG replacement snap leads

Product name	Order code	Specification	Note
300-Series replacement snap lead	545350	300-Series replacement snap lead, red LL, 75 cm/ 30 in	
	545351	300-Series replacement snap lead, black LA, 75 cm/ 30 in	
	545352	300-Series replacement snap lead, white RA, 75 cm/ 30 in	

	545353	300-Series replacement snap lead, brown V, 75 cm/ 30 in	
	545354	300-Series replacement snap lead, red LL, 125 cm/ 49 in	
	545355	300-Series replacement snap lead, green FL, 125 cm/ 49 in	

### ECG cables, miscellaneous

Product name	Order code	Specification	Note
Combiner for 300-Series 3-lead set	545390 pkg of 3 pcs	Combiner for 300-Series 3-lead sets	
Combiner for 300-Series 5-lead set	545391 pkg of 3 pcs	Combiner for 300-Series 5-lead sets	
Organizer for 300-Series 3-lead set	545392 pkg of 10 pcs	Organizer for 300-Series 3-lead sets	
Organizer for 300-Series 5-lead set	545393 pkg of 10 pcs	Organizer for 300-Series 5-lead sets	
Bed sheet clip	891192 pkg of 3 pcs	Bed sheet clip	Use with all Datex-Chmeda ECG cables.

### Electrodes

Product name	Order code	Specification	Note
ECGelectrode	572683 pkg of 50 pcs	ECGelectrodes, solid gel, Ag/ AgCl	Disposable.
Infant ECGelectrode	572684 pkg of 15 pcs	Infant ECGelectrodes, safety pin (DIN42- 802) connector, solid gel, Ag/ AgCl	Disposable. Connects directly to 300-Series trunk cable.

## TEMPERATURE PROBES

### Temperature probes, reusable

Product name	Order code	Specification	Note
Skin temperature probe	16560	2.8 m/ 9 ft, 400 series thermistor, $\varnothing$ 10 mm, tc= 4.5 sec Accuracy: 0-25° C $\pm$ 0.2° C 25-50° C $\pm$ 0.1° C	For adults and infants. Can be autoclaved at 121° C/ 250° F.
Central temperature probe	16561	Adult, 2.8 m/ 9 ft, 400 series thermistor, $\varnothing$ 4 mm, tc= 6.9 sec Accuracy: 0-25° C $\pm$ 0.2° C	Oesophageal or rectal. Can be autoclaved at 121° C/ 250° F.

		25-50° C ± 0.1° C	
	165611	Pediatric, 2.8 m/ 9 ft, 400 series thermistor, Ø 3 mm, tc = 3.2 sec Accuracy: 0- 25° C ± 0.2° C 25- 50° C ± 0.1° C	Cesophageal or rectal. Can be autoclaved at 121° C / 250° F.

## NBP CUFFS

### NBP cuffs, reusable

Product name	Order code	Specification	Note
Reusable cuff	572436	Large adult Color code: red For arm circumference 33 - 47 cm	Requires black adult hose.
	572435	Standard adult Color code: blue For arm circumference 25 - 35 cm	Requires black adult hose.
Reusable cuff	572434	Small adult Color code: gray For arm circumference 18 - 26 cm	Requires black adult hose.
	877408	Child Color code: green For arm circumference 10 - 19 cm	Requires black adult hose.
Reusable infant cuff	877407	Infant Color code: tan For arm circumference 9 - 14 cm	Requires white infant hose.
Replacement cover, adult	572437	Replacement cover for standard adult cuff 572435 Color code: blue	

### NBP cuffs, single use

Product name	Order code	Specification	Note
Single use infant cuff	572405 pkg of 10 pcs	Infant cuff #5, for arm circumference 9.6 cm - 14.3 cm	Requires white infant hose.

### NBP cuff hoses

Product name	Order code	Specification	Note
Adult hose, black	877235	Black, 3 m/ 10 ft	Use with NBP cuffs 572436,

			572435, 572434, 877408.
	879739	Black, 6 m/ 20 ft	Use with NIBP cuffs 572436, 572435, 572434, 877408.
Infant hose, white	877514	White, 3 m/ 10 ft	Do not use with Light Monitor F-LM and F-LMP. Use with reusable NIBP cuff 877407 and single use cuffs 572403, 572404, 572405.
Infant hose, white	890639	White, 6 m/ 20 ft	Do not use with Light Monitor F-LM and F-LMP. Use with reusable NIBP cuff 877407 and single use cuffs 572403, 572404, 572405.

### Connectors

Product name	Order code	Specification	Note
Plastic connectors	64655	Plastic connectors for upgrading adult NIBP cuffs and hoses	For cuffs: 572434, 572435, 572436, 877408 For hoses: 877235, 879739, 877913

## INVASIVE BLOOD PRESSURE TRANSDUCERS

NOTE: Companies like Abbott, Baxter/ Edwards, COBE, Beckton-Dickinson and Utah Medical can provide adapter cables for Datex-Ohmeda monitors to be used with disposable transducers from these companies.

### InBP transducers and cables, reusable

Product name	Order code	Specification	Note
Reusable InBP transducer	16576	SensoNor 840, 3 m/ 10 ft Sensitivity: 50 $\mu$ V/V/cmHg	Requires disposable dome 16578 and flushing kit 16577.
Reusable transducer	165700	Spectramed P10EZ-1, 0.45 m/ 1.5 ft. Sensitivity: 50 $\mu$ V/V/cmHg	Requires flushing kit 16571 and adapter cable 54586.
Holder for InBP transducer	16579	Holder for 2 x SensoNor 840 transducers	
Adapter cable	54586	Cable 3.8 m/ 12 ft	Use with Beckton-Dickinson DTX disposable pressure transducers or Spectramed P10EZ-1.
Adapter cable	875408	Cable 30 cm/ 1 ft	Use with HP 1290C-type pressure transducers.

**Flushing kits, disposable**

Product name	Order code	Specification	Note
Disposable flushing kit	16577 pkg of 10 kits	Disposable flushing kit for transducer SensoNbr 840	Sterile. Each kit includes tubing and one dome.
Disposable dome	16578 pkg of 50 pcs	Disposable dome for transducer SensoNbr 840	Sterile.
Disposable flushing kit	16571 pkg of 5 kits	Disposable flushing kit for transducer Spectramed P10EZ-1	

**INTERFACE CABLES****Interface cables for configured monitors**

Product name	Order code	Specification	Note
Light Monitor-Printer cable	894193	Light Monitor, models F-LM1 and F-LMP1 - printer cable	Local laser printer cable (PCL5).

**MOUNTING ELEMENTS**

Product name	Order code	Specification	Note
Portable monitor wall mount	572238	Portable Monitor Wall Mount	Requires mounting plate 890915 for Light Monitor. Max. load 27 kg.
Portable monitor roll stand	572235	Portable Monitor Roll Stand	Requires mounting plate 890915 for Light Monitor. Includes basket for monitor accessories.
Light monitor mounting plate	890915	Light Monitor Universal Mounting Plate	Mounts Light Monitor to Portable Monitor Wall Mount, Portable Monitor Roll Stand and to a fixed vertical pole within diameter range: 25 - 32 mm (1 - 1.25 in) with maximum load of 7.5 kg (16.5 lbs). Includes mounting plate adapter 572623.
Mounting plate adapter	572623	Mounting plate adapter for Light Monitor	Included in Light Monitor Universal Mounting Plate, 890915.
Light Monitor protective case	737731	Protective case for Datex-Ohmeda Light Monitor	

## MISCELLANEOUS

Product name	Order code	Specification	Note
Light Monitor battery	896895	Light Monitor Battery Module w/ 2 batteries, F-LBAT	For Light Monitor. NiCd battery.
Light Monitor data card	887045	Light Monitor data card for models F-LM1 and F-LMP1	English. Allows data storage of physiological trends for data continuum.
	887047	Light Monitor data card for models F-LM1 and F-LMP1	French. Allows data storage of physiological trends for data continuum.
Dust filter	886841	Dust filter	For Datex-Ohmeda Light Monitor.
Thermal recorder paper	74205 pkg of 20 rolls	Thermal recorder paper - width 50 mm/ 2 in	

## ACCESSORY KITS

### Hemodynamic accessory kits

Product name	Order code	Specification	Note
Hemodynamic accessory kit	877973	<ul style="list-style-type: none"> <li>- 1 adult NIBP hose (877235)</li> <li>- 1 standard adult cuff (572435)</li> <li>- 1 three-lead trunk cable, IEC color coding (545300)</li> <li>- 1 three-lead set, IEC color coding (545315)</li> <li>- 1 adult central temperature probe (16561)</li> <li>- 1 Sat Sensor Cable, 3 m/ 10 ft (SAS-C3)</li> <li>- 1 FingerSat Sensor, cable 1.3 m/ 4 ft (SAS-F)</li> </ul>	Includes ECG cables with IEC color coding.
Hemodynamic accessory kit	877974	<ul style="list-style-type: none"> <li>- 1 adult NIBP hose (877235)</li> <li>- 1 standard adult cuff (572435)</li> <li>- 1 three-lead trunk cable, AAMI color coding (545302)</li> <li>- 1 three-lead set, AAMI color coding (545317)</li> <li>- 1 adult central temperature</li> </ul>	Includes ECG cables with AAMI color coding.

		<p>probe (16561)</p> <ul style="list-style-type: none"> <li>- 1 Sat Sensor Cable, 3 m/ 10 ft (SAS-C3)</li> <li>- 1 FingerSat Sensor, cable 1.3 m/ 4 ft (SAS-F)</li> </ul>	
NIBP, ECG and SpO <sub>2</sub> accessory kit	890935	<ul style="list-style-type: none"> <li>- 1 adult NIBP hose (877235)</li> <li>- 1 standard adult cuff (572435)</li> <li>- 1 three-lead trunk cable, IEC color coding (545300)</li> <li>- 1 three-lead set, IEC color coding (545315)</li> <li>- 1 Sat Sensor Cable, 3 m/ 10 ft (SAS-C3)</li> <li>- 1 FingerSat Sensor, cable 1.3 m/ 4 ft (SAS-F)</li> </ul>	Includes ECG cables with IEC color coding.
NIBP, ECG and Temp accessory kit	877971	<ul style="list-style-type: none"> <li>- 1 adult NIBP hose (877235)</li> <li>- 1 standard adult cuff (572435)</li> <li>- 1 three-lead trunk cable, IEC color coding (545300)</li> <li>- 1 three-lead set, IEC color coding (545315)</li> <li>- 1 adult central temperature probe (16561)</li> </ul>	Includes ECG cables with IEC color coding.
NIBP, ECG and Temp accessory kit	877972	<ul style="list-style-type: none"> <li>- 1 adult NIBP hose (877235)</li> <li>- 1 standard adult cuff (572435)</li> <li>- 1 three-lead trunk cable, AAMI color coding (545302)</li> <li>- 1 three-lead set, AAMI color coding (545317)</li> <li>- 1 adult central temperature probe (16561)</li> </ul>	Includes ECG cables with AAMI color coding.

**SpO<sub>2</sub> accessory kit**

Product name	Order code	Specification	Note
SpO <sub>2</sub> accessory kit	875697	<ul style="list-style-type: none"> <li>- 1 Sat Sensor Cable, 3 m/ 10 ft (SAS-C3)</li> <li>- 1 FingerSat Sensor, cable 1.3 m/ 4 ft (SAS-F)</li> </ul>	



## 24. INDEX

### A

AAMI Codes, ECG electrodes, 57  
Adapters  
  mainstream CO<sub>2</sub>, 57  
Adjusting  
  alarm limits, 29  
  alarm volume, 29  
  beat volume, 57  
  CO<sub>2</sub> scale, 57  
  default settings, 29  
  ECG settings, 57  
  invasive blood pressure settings, 57  
  monitor settings, 29  
  NIBP settings, 57  
  pulse oximetry settings, 57  
  Respiration display, 57  
  screen, 29  
  temperature settings, 57  
  time and date, 29  
  trends, 29  
Alarm  
  sound, 29  
Alarms, 29  
  audio alarm pattern, 29  
  auto limits, 29  
  automatic recording, 29  
  categories, 29  
  default limits, 29  
  pulse oximetry, 57  
  Reminder volume, 29  
  setup, 29  
  silencing, 29  
  smart start, 29  
  source, 29  
Alcohol  
  cleaning, 15  
Arrhythmia  
  Warning, 1  
Artefacts

  Of movement, 57  
  Respiration, 57  
AS/3 monitors, 29  
Auto alarm limits, 29  
Autoclave, 15  
Autocycling, 57  
Automatic Alarm Recording, 29

### B

Backup Battery, 15  
Batteries, 1, 15  
  cautions, 1  
  charging, 1, 15  
  checklist, 91  
  disposing of, 15  
  removing, 15  
  storing, 15  
Battery alarm, 15  
Battery Module, 15  
beat volume, 57  
BF, 1  
Breathing tubes  
  Warning, 1

### C

Cadmium, 15  
Calibration  
  IBP, caution, 1  
Calibration check  
  mainstream CO<sub>2</sub>, 57  
  NIBP, 57  
Calibration check, NIBP, 57  
Carbon dioxide. *See* CO<sub>2</sub>  
Carbon monoxide, 57  
Cascaded ECG, 57  
Cautions, 1  
Changing  
  alarm setup, 29  
  ECG setup, 57  
  invasive pressure setup, 57

- monitor setup, 29
- NIBP setup, 57
- Respiration setup, 57
- screen setup, 29
- temperature setup, 57
- time and date, 29
- trend setup, 29
- Charging batteries, 15
- Checklist, 91
- Cleaning, 15
  - airway accessories, 15
  - ECG cables, 15
  - invasive pressure, 15
  - NIBP Cuff, 15
  - NIBP hose, 15
  - Pulse oximetry, 15
  - temperature probes, 15
- CO<sub>2</sub>, 57
  - checklist, 91
  - cleaning the accessories, 15
- CO<sub>2</sub> waveform, 57
- Collecting Data, 29
- Combine Pressures, 29
- Combined pressures, 57
- Compensation, N<sub>2</sub>O and O<sub>2</sub>, 57
- ComWheel, 15
- Configuration, 1
- Connecting
  - mainstream CO<sub>2</sub> sensor, 57
- Connectors
  - patient cables, 15
- Continuous NIBP measurement, 57
- Contrl, 57
- CS/3 monitors, 29
- Cycling, NIBP, 57

## **D**

### **Data**

- collecting, 29
- entering patient data**, 29

DataCard, 29

Date, 29

- Def sync signal, 91
- Default, 29
  - alarm limits, 29
  - settings, 29
- Defaults
  - returning to, 29
- Defibrillator-proof, 1
- Degree of protection against harmful ingress
  - of water, 1
- Description
  - patient cable connectors, 15
  - rear panel, 15
  - screen, 15
- Detection limits**
  - respiration**, 57
- Digit Fields, 29
- Discarding the monitor, 1
- Disinfecting, 15
- Display, 15
- Disposal, 1
- DURASENSOR, 57
- DURA-Y, 57
- Dust filter
  - cleaning, 15
- Dyshemoglobins, 57

## **E**

- ECG, 57
  - adjustments, 57
  - applying electrodes, 57
  - checklist, 91
  - electrodes, 57
  - selecting lead, 57
- Electrical interference, respiration, 57
- Electrodes, 57
- Electrosurgery, 57
  - Warning, 1, 57
- End of the Day, 15
- Entering name, 29
- Erasing
  - trend, 29
- Erasing Trend Data, 29

**F**

Flash memory card, 29  
Freeze, 15

**G**

General alarm pattern, 29  
Getting started, 15  
Guteraldehyde, 15  
Graphic trends, 29  
Grid, in ECGdisplay, 57

**H**

Heart rate source, 57  
Heavy metal waste, 15  
Hemoglobin, 57  
Hepatitis, 15  
HV, 15  
Hospital grade, 1  
HRsource, 57

**I**

**ID**, 29  
IEC codes, ECG electrodes, 57  
IEC-601-1, 1  
Impedance respiration, 57  
In-Between Patients, 15  
Inflation limits, 57  
Information Centre, 29  
Infrared light, 57  
Install/ Service, 29  
Installing, 1  
    configuration, 1  
    monitor on the rail, 1  
    network, 1  
    power adapter, 1  
    printer, 29  
Intended Purpose, 1  
Intermittent Mechanical Ventilation, 57  
Intervals, NIBP measurement, 57  
Invasive blood pressure, 57  
    checklist, 91  
    settings, 57

    zeroing transducer, 57  
IPX-class, 1  
ISO alarm pattern, 29  
Isolating transformer, 1

**K**

Keys, 15

**L**

Labels  
    invasive blood pressure, 57  
    temperature, 57  
Limitations  
    Respiration measurement, 57  
Local printing, 29  
Low dead-space adapter, 57

**M**

Magnetic resonance imaging (MRI)  
    Warning, 1  
Mainstream CO<sub>2</sub>, 57  
Maintaining  
    batteries, 15  
Maintenance, 91  
Measuring limitations  
    Respiration, 57  
Measuring Principle  
    invasive blood pressure, 57  
    NIBP, 57  
    pulse oximetry, 57  
Monitor Setup, 29  
Monitor-to-Monitor Communication, 29  
MRI  
    Warning, 1  
Multi View, 29

**N**

Name, patient's, 29  
Nellcor Compatible, 57  
Nellcor sensors, pulse oximetry, 57  
Network, 29  
    installing, 1

- NBP, 57
  - checklist, 91
  - double check, 57
  - settings, 57
  - setup, 57
- N-Cd, 15
- N-LDATA, 29
- N-LDNET, 29
- N-LNET, 29
- Non-invasive blood pressure, 57
- Normal Screen, 15
- Numerical fields, 29
- Nurse Call, 29
  - disabling, 29
- Nurse call signal, 91
- O**
- On/ standby, 15
- Oscillometric principle, 57
- Output signals, 91
- OXBAND, 57
- OXCLIC, 57
- OXSENSORII, 57
- Oxygen saturation, 57
- P**
- Pacemaker
  - displaying, 57
  - monitoring patients, 57
  - Warning, 1
- Paediatric mainstream adapter, 57
- Paper speed, 29
- Partial pressure, 57
- Patient Data**, 29
- Patient ID**, 29
- Patient View, 29
- Permanent settings, 29
- Placing
  - monitor, 1
- Placing Electrodes, 57
- Plethysmographic
  - Scale, 57
  - Waveform, 57
- Power adapter, 1
  - for transport vehicles, 1
- Preset alarm limits, 29
- Pressure
  - combined waveforms, 29
  - invasive blood, 57
  - non-invasive blood, 57
  - partial, 57
- Printing, 29
  - A4, 29
  - letter size, 29
  - local, 29
  - printer installation, 29
  - trends, 29
- Priorities of alarms, 29
- Problem-solving, 91
- Protective case, 1
- Pulse oximetry, 57
  - Alternative, 57
  - applying sensors, 57
  - checklist, 91
  - selecting sensor, 57
  - settings, 57
- Pulse rate, 57
- Pulse Search, 57
- R**
- Rear Panel, 15
- Recorder, 29
  - adding paper, 29
  - setup, 29
  - start on alarms, 29
- Recording
  - alarms automatically, 29
  - trends, 29
  - waveforms, 29
- Recycling, 1
- Regular checks, 91
- Reminder volume, 29
- Resetting all, 29
- Resolution

- trend, 29
- Respiration, 57
  - Measuring limitations, 57
- Respiration rate, 57
- Respiration rate source, 57
- Returning to defaults, 29
- Rotating wheel, 15
- S**
- S/D, 29, 57
- Safety Symbols, 1
- Save as Defaults, 29
- Scale
  - Automatic Plethysmographic, 57
  - CO<sub>2</sub>, 57
  - Pleth, 57
- Scaling
  - ECG, 57
  - invasive blood pressure, 57
- Screen, 15
- Screen setup, 29
- Selecting
  - ECG lead, 57
  - heart rate source, 57
  - paper size, 29
  - parameters for display, 29
  - printer, 29
  - pulse oximetry sensor, 57
  - temperature unit, 57
- Setting
  - alarm volume, 29
  - screen layout, 29
  - time and date, 29
- Signals
  - defibrillator synchronisation, 91
  - nurse call, 91
- Silencing alarms, 29
- SpO<sub>2</sub>, 57
  - Nellcor sensors, 57
  - response, 57
- Spont, 57
- Spontaneous
  - Breathing, 57
- Starting a case, 29
- STAT mode, 57
- Steam autoclave, 15
- Sterilization, 15
- Stopping a case, 29
- Sub menu, 1
- Sweep speed
  - CO<sub>2</sub>, 57
  - invasive pressure, 57
- Symbols, 1
  - battery status, 15
- T**
- Temperature
  - checklist, 91
  - setup, 57
  - unit, 57
- Testing Temperature, 57
- Thermal paper, 29
- Thick waves, 29
- Time, 29
- Transducer
  - Oxygen, 57
- Transducer kit, 57
- Transport
  - power adapter, 1
- Trends, 29
  - changing page, 29
  - erasing, 29
  - setup, 29
  - viewing graphic, 29
  - viewing numerical, 29
- Troubleshooting, 91
- Tuberculosis, 15
- Turning Audible Alarms Off/ On, 29
- Type BF, 1
- Type of protection against electrical shock,  
1, 15
- U**
- Unit

CO<sub>2</sub>, 57  
Unit conversions, CO<sub>2</sub>, 57  
Unpacking, 1  
Using  
    data card, 29  
    Network, 29

**V**

Vasoconstrictive drugs, 57  
Venous Stasis, 57  
Ventilation mode, 57  
Viewing Graphic Trends, 29  
Viewing Numerical Trend, 29

**W**

Warnings, 1  
washing machine, 15  
Waveforms  
    displaying, 29  
    invasive blood pressure, 57  
    scaling ECG, 57  
    scaling plethysmographic, 57  
    sweep speed, 57  
    thick waves, 29

**Z**

Zeroing the transducer, 57