

## Servo Screen 390

### Service Manual

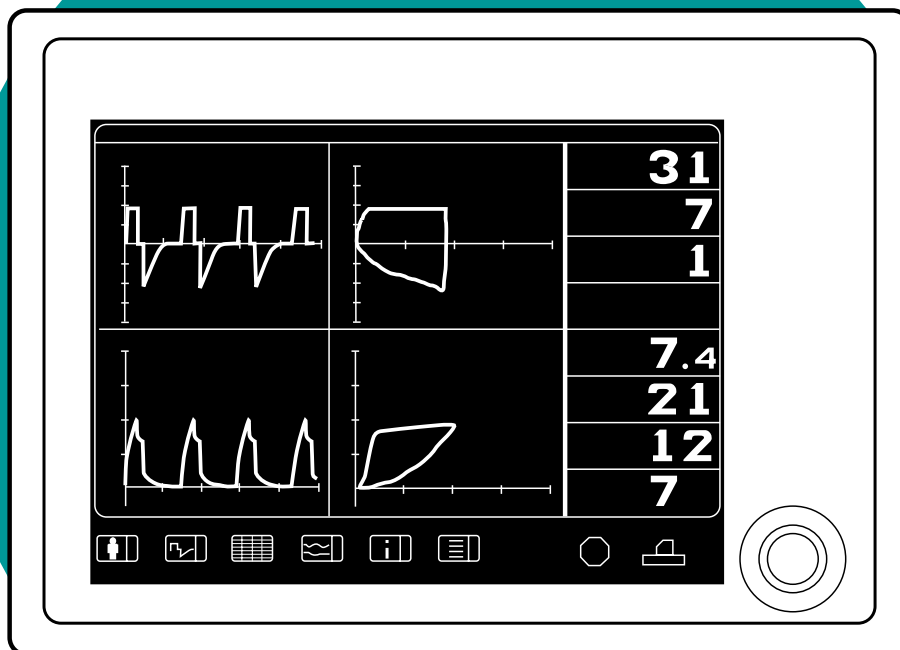

# Important

## General

The documentation for the Servo Screen 390 consists of:

- Operating Manual
- Service Manual
- Spare Parts List

The Operating Manual is an indispensable complement to the Service Manual for proper servicing.

As the Servo Screen 390 is a part of the Servo Ventilator system, there are also other documents that can be useful when servicing the Servo Screen 390:

- Servo Ventilator 300/300A
  - Operating Manual
  - Service Manual
  - Circuit Diagram
  - Reference Manual, Computer Interface
- Servo Ventilator 900C/E
  - Operating Manual
  - Service Manual
  - Circuit Diagram
  - Reference Manual, SCM 990

Text inside a box is used to highlight important information.

In addition to the Important information given here and in the related documents (e. g. in the Operating Manual), always pay attention to applicable local and national regulations.

Responsibility for the safe functioning of the equipment reverts to the owner or user in all cases in which service or repair has been done by a non-professional or by persons who are not employed by or authorized by Siemens, and when the equipment is used for other than its intended purpose.

There are two different versions of the Servo Screen 390:

- Serial No. 10000 or lower – Equipped with Computer board PC 1662 and a software memory card of PC Card™-type.
- Serial No. 10001 or higher – Equipped with Computer board PC 1835 and a software memory card of CompactFlash™-type.

All information in this Service Manual is valid for both versions unless stated otherwise.

## Hazard notices

Make sure that all cables are disconnected from the connection ports when disassembling or assembling the Servo Screen 390.

## Service

When working with ESD sensitive components, always use a grounded wrist band and grounded work surface. Adequate service tools must also be used.

Worn-out batteries must be returned to the place of purchase or to a place where they can be safely disposed of. Batteries must not be disposed of with ordinary waste. All other parts shall be discarded according to hospital rules and in an environmentally safe way.

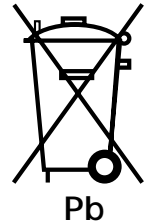

## Functional check

After any service intervention in the Servo Screen 390, perform a Functional check according to the instructions in the Operating Manual.

## To responsible service personnel

The contents of this document are not binding. If any significant difference is found between the product and this document, please contact Siemens for further information.

We reserve the right to modify products without amending this document or advising the user.

Only personnel authorized by Siemens shall be permitted to service or repair the Servo Screen 390. Only Siemens-Elementa genuine spare parts must be used. PC boards (spare parts) must always be kept in a package for sensitive electronic devices. Siemens will not otherwise assume responsibility for the materials used, the work performed, or any possible consequences of same.

# Contents

1. Introduction .....	5	1
2. Description of functions .....	11	2
3. Disassembly and assembly .....	17	3
4. Service procedures .....	25	4
5. Troubleshooting .....	37	5
6. Index .....	41	6
7. Diagrams .....	45	7



# 1. Introduction

General .....	6
Hardware overview .....	7
Main sections .....	8
Display section .....	8
Computer section .....	9
Firmware/software overview .....	9
Firmware .....	9
Software .....	9

1

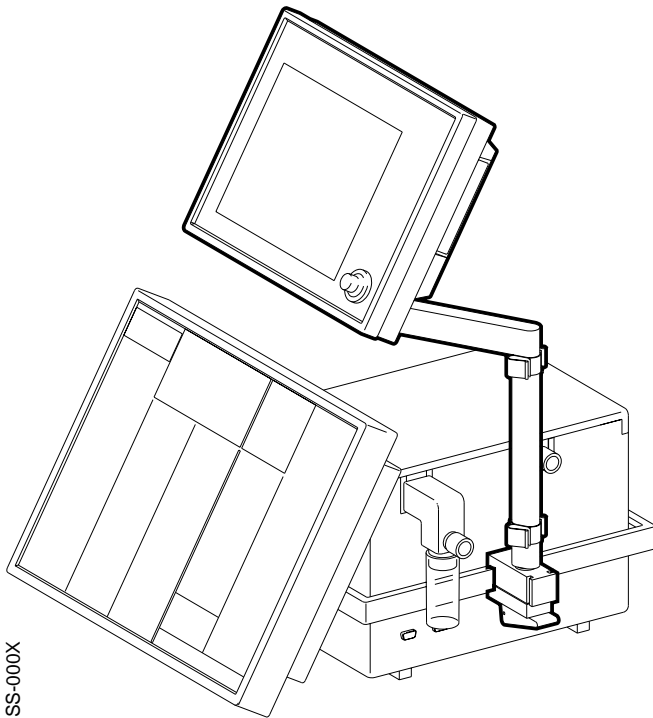

SS-000X

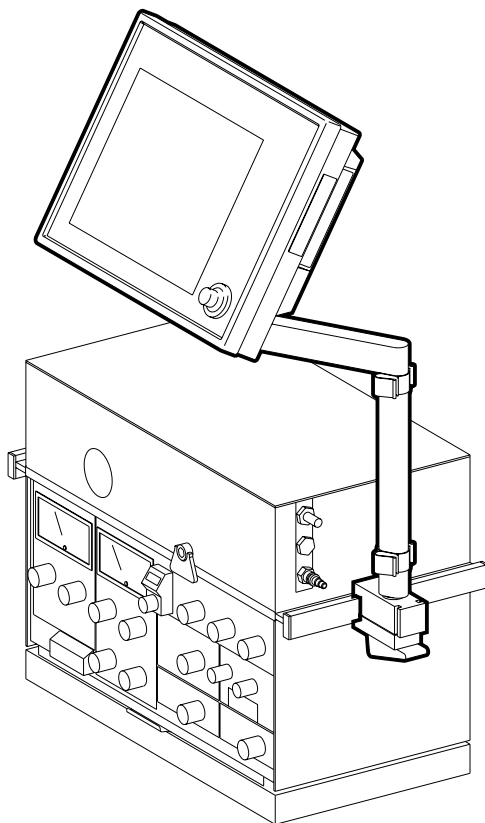

SS-001X

## General

Servo Screen 390 is a computer unit that reads information from a ventilator, makes calculations, and presents the information to the operator in a clear, logically organized manner.

The primary purpose of Servo Screen 390 is to provide a central location for the display of all parameter information from the ventilator. It provides information on system and patient conditions, logically assembled in a way that presumes presentations including curves.

Servo Screen 390 does not control the ventilator or any other medical equipment.

Servo Screen 390 is compatible with the following ventilator systems:

- Servo Ventilator 300/300A
- Servo Ventilator 900C/E systems that use Servo Computer Module 990 (SCM 990)

More information about the compatible ventilators can be found in the chapter "Technical specifications" in the Operating Manual.

## Hardware overview

Servo Screen 390 unit is a small, compact, ergonomically-designed computer unit. It is manufactured from materials suitable for use in a clinical environment and is designed specifically for integration with existing ventilator equipment.

The primary features of the Servo Screen 390 are:

- An electro-luminescent, mono-chromatic screen (1) which provides displays that are clearly visible within the bedside working area.
- A power on/off switch (2).
- A single operator control including a pulse generator in the form of an easy-to-use knob (3), which can be only turned or pressed.
- A removable software memory card under the protective cover (4) for easy software updates. More information about software upgrading can be found in the chapter 4, "Service procedures".
- Connection ports as follows:
  - KBD port (5) for connection of a keyboard. For service use only.
  - PRINTER port (6) for connection of a printer.
  - COM port (7) for serial communication with other equipment. For future applications. Dependent on the software version.
  - VENT port (8) for serial communication with the ventilator.
  - CRT port (9) for connection of an external monitor.
  - PWR port (10) for connection to a power source.

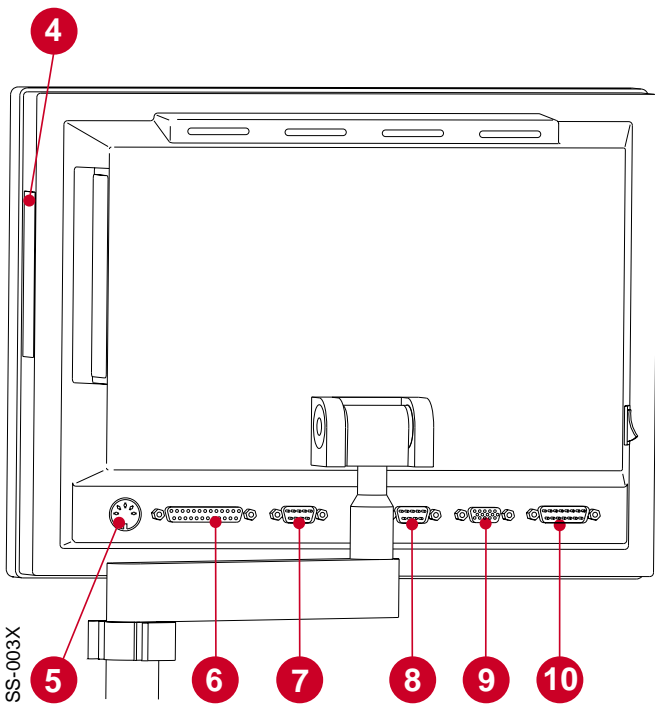
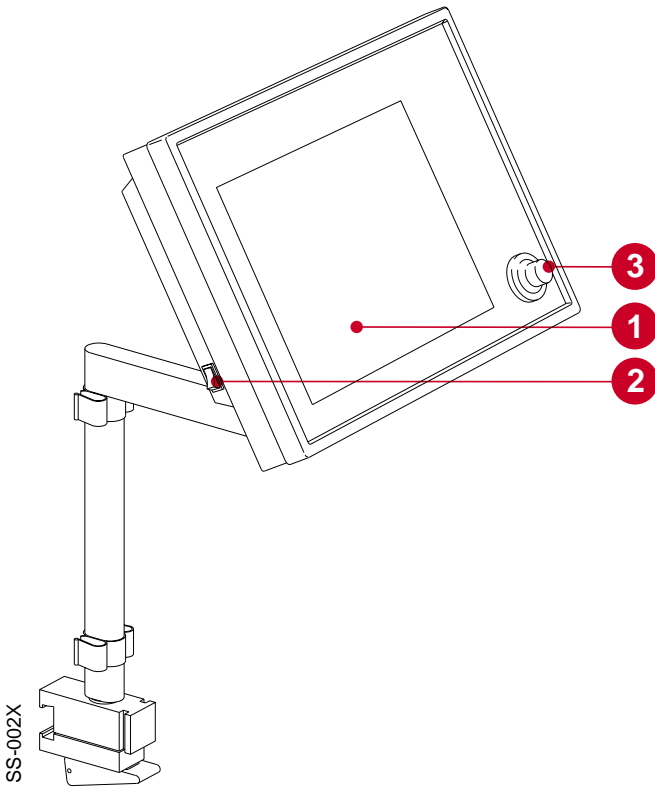

More information about the connection ports can be found in the chapter 7, "Diagrams".

1

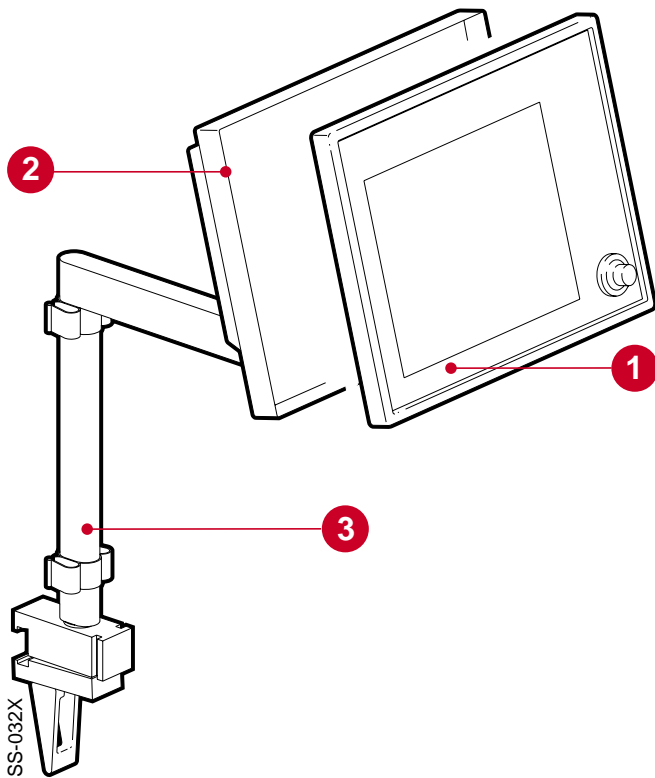

## Main sections

Servo Screen 390 can be separated into two main sections:

- Display section (1)
- Computer section (2)

The support arm (3) is always used to mount the Servo Screen 390 on a ventilator cart or wall rail.

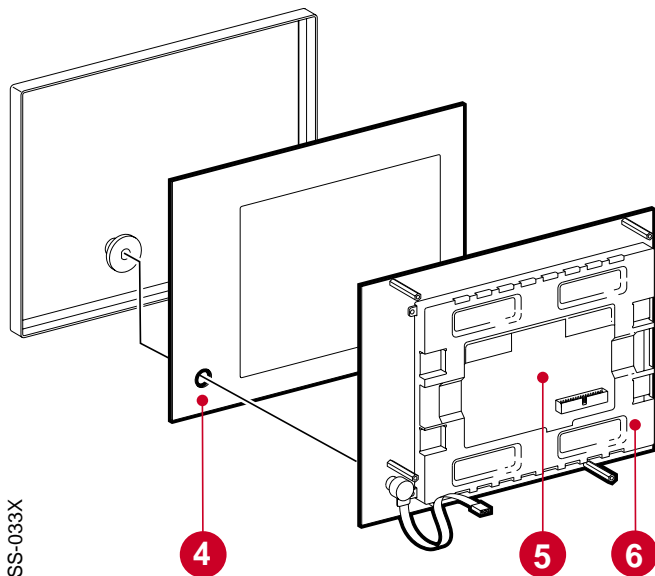

## Display section

The anti-reflex coated front panel filter (4) protects the display (5) and makes it easy to keep the display clean.

To reduce EMC radiation to the environment, a cover plate (6) is mounted at the rear of the display.

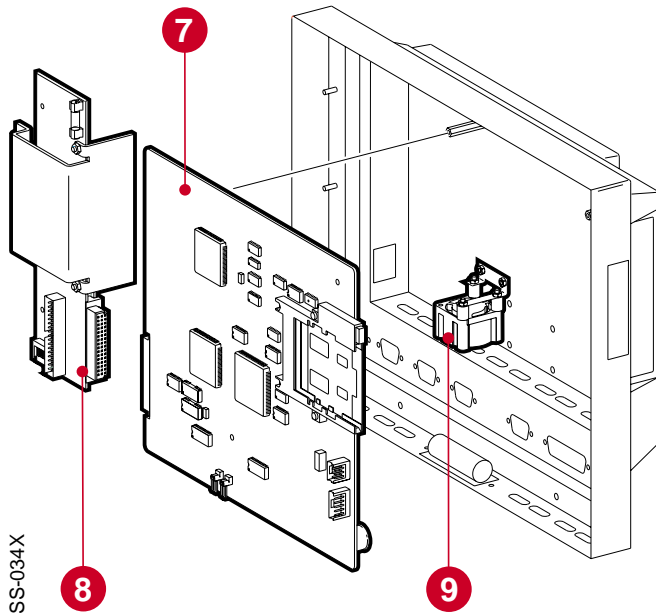

### Computer section

The two PC boards mounted in the computer section are:

- Computer board (7), containing micro-processor, SS390-BIOS, internal memory and an interface for the software memory card. All connection ports except the power port are mounted on the computer board. There are two different versions of the Computer board (7), PC 1662 and PC 1835.
- Adapter board PC 1663 (8), containing voltage distribution and display interface.

A fan (9) inside the computer unit provides forced air cooling for the PC boards. The fan has a rubber suspension to reduce noise.

## Firmware/software overview

### Firmware

The SS390-BIOS on the computer board initializes the system and starts the application software.

The SS390-BIOS can be upgraded if required.

### Software

The operating system and the Servo Screen application software is supplied on a removable software memory card. The user interface provided by this software is described in the Operating Manual.

The software memory card is very easy to replace in case of future software upgrades.



## 2. Description of functions

General .....	12
Power supply .....	12
With Servo Ventilator 300/300A .....	12
With Servo Ventilator 900C/E .....	12
Adapter board .....	13
General .....	13
Voltage distribution .....	13
Signal adaption .....	13
Brightness control .....	13
Fan control .....	13
Board identity .....	13
Internal power cable .....	13
ON/OFF switch .....	14
Display connection cable .....	14
Fan .....	14
Computer board .....	14
General .....	14
Software memory card .....	15
Battery .....	15
Pulse generator .....	16
Connection ports .....	16
Display .....	16

## General

The text in this chapter refers to the block diagram in chapter 7, "Diagrams" (on the inside of the back cover).

2

## Power supply

### With Servo Ventilator 300/300A

The power supply is connected to the power inlet port PWR (P21) on Servo Screen 390. The internal power cable connects the power inlet port to the ADAPTER BOARD at P18. The PWR port is described in chapter 7, "Diagrams".

Power to the Servo Screen 390 is supplied from the Servo Ventilator 300/300A auxiliary equipment output N78.

Connector N78 is described (output signals and limitations) in the Servo Ventilator 300/300A – Service Manual.

### With Servo Ventilator 900C/E

The power supply is connected to the power inlet port PWR (P21) on Servo Screen 390. The internal power cable connects the power inlet port to the ADAPTER BOARD at P18. The PWR port is described in chapter 7, "Diagrams".

Power to the Servo Screen 390 is supplied from an AC Power Adapter 124 when used with a Servo Ventilator 900C/E.

Technical specifications for the AC Power Adapter 124:

Mains power supply .....	100 – 240 V
Mains frequency .....	50 – 60 Hz
ON/OFF-indication .....	Green LED indicates power on
Output voltage range .....	24 V DC $\pm$ 10%
Output power .....	max. 50 W
Earth leakage current, normal condition (IEC 601-1-1) .....	30 A
Fuse (internal) .....	2.4 A slow

## Adapter board

### General

The functional blocks on the ADAPTER BOARD PC 1663 are:

- VOLTAGE DISTRIBUTION
- SIGNAL ADAPTION
- BRIGHTNESS CONTROL
- FAN CONTROL
- BOARD IDENTITY

Further functional blocks connected to the ADAPTER BOARD are:

- INTERNAL POWER CABLE
- ON/OFF SWITCH
- DISPLAY CONNECTION CABLES
- FAN

The ADAPTER BOARD is connected directly to the COMPUTER BOARD via N5.

### Voltage distribution

The inlet power is fused at F1 (3.15 A fast). Replacing the fuse is described in chapter 4, "Service procedures".

The different voltage levels used in the Servo Screen 390 are regulated by and distributed from this block.

The distributed voltage levels are:

1. +12 V ( $\pm 5\%$ ), max. 2.6 A. An overvoltage protection cuts the voltage distribution at typ. 14.6 V.
2. +5 V ( $\pm 3\%$ ), max. 3.0 A. An overvoltage protection cuts the voltage distribution at typ. 6.2 V.

### Signal adaption

The control signals from the COMPUTER BOARD PC 1662/PC 1835 to the display are adapted in this block and furthered to the main block DISPLAY via P20.

### Brightness control

The brightness in the display can be selected using the SYSTEM MENU in the application software. The selected brightness is then controlled via this block and furthered to the main block DISPLAY via P19.

When exchanging PC 1663, a setting of the brightness level may be required, refer to chapter "3. Disassembly and assembly", section "Assembling the computer section".

### Fan control

An NTC-resistor on PC 1663 senses the air temperature inside the Servo Screen 390.

If the air temperature inside the unit exceeds approx. 53°C (127°F), the fan is switched on. When the temperature drops below approx. 45°C (113°F), the fan is switched off.

### Board identity

PC 1663 is equipped with a BOARD IDENTITY function that makes it possible for the COMPUTER BOARD PC 1662/PC 1835 to recognize the PC 1663 version. This function is intended for possible future versions, e.g. new types of displays.

### Internal power cable

The internal power cable connects the PC 1663 (P18) with the power inlet port PWR (P21).

## ON/OFF switch

The ON/OFF SWITCH turns the power supply to the Servo Screen 390 on or off. This is the only device for turning the unit on or off. No other action is needed, e. g. when shutting down the Servo Screen 390.

## Display connection cables

The two DISPLAY CONNECTION CABLES connect the ADAPTER BOARD to the DISPLAY.

One flat cable connects SIGNAL ADAPTION signals from P20 on PC 1662/PC 1835 to display connector J1.

One cable connects BRIGHTNESS CONTROL signals from P19 on PC 1662/PC 1835 to display connectors J2 and J3.

## Fan

The Servo Screen 390 is equipped with a FAN. The fan is controlled by the block FAN CONTROL.

The purpose of this fan is to provide forced air cooling inside the unit. The air stream enters through the ventilation holes in the lower part of the unit and exits through the ventilation holes in the upper part of the unit.

## Computer board

### General

There are two different versions of the COMPUTER BOARD:

- PC 1662. Factory mounted on Servo Screen 390 with Serial No. 10000 or lower. Software memory card of PC Card™-type is used.
- PC 1835. Factory mounted on Servo Screen 390 with Serial No. 10001 or higher. Software memory card of CompactFlash™-type is used.

The two PC boards are interchangeable. Refer to further information in the Spare Parts List when replacing a PC 1662 with a PC 1835.

The functional blocks on the COMPUTER BOARD PC 1662/PC 1835 are:

- MICROPROCESSOR
  - 80486SX, 25 MHz on PC 1662
  - Pentium, 166 MHz on PC 1835.
- VGA CONTROLLER
- BUS INTERFACE including:
  - Diskette drive interface (not used)
  - Hard disk interface (for test purposes only)
  - Two serial ports
  - One parallel port
  - Keyboard controller
- PULSE GENERATOR INTERFACE
- VOLTAGE & FUNCTION MONITORING
- INTERNAL MEMORY. The size of the internal memory is optimized for the software version. The internal memory is mounted on a standard socket and can be replaced if required by future software upgrades.
- VIDEO MEMORY

- SRAM (only on PC 1662). This battery backed up memory contains software settings (e.g. battery replacement date), TRENDS and the EVENT LIST.  
Note – On PC 1835, TRENDS and EVENT LIST are stored on the CompactFlash™ card and thus not dependent on the battery.
- SOFTWARE MEMORY CARD INTERFACE
- SS390-BIOS. Contains low-level software (BIOS, drivers, start-up screen including software loading messages and initial program load of the application software). There are two different versions of the SS390-BIOS:
  - SS390-PROM mounted on PC 1662.  
This PROM is mounted on a PROM socket and can be upgraded (replaced) if required.
  - SS390-FLASH mounted on PC 1835.  
This FLASH memory can be upgraded (new software downloaded) if required.

Refer to chapter 4, "Service procedures" for further information regarding upgrades.

The computer is equipped with procedures for self-testing and the self-test result can be displayed in the SERVICE MENU. See chapter 4, "Service procedures".

Further functional blocks connected to the COMPUTER BOARD are:

- SOFTWARE MEMORY CARD
- BATTERY
- PULSE GENERATOR
- CONNECTION PORTS

The COMPUTER BOARD is connected directly to the ADAPTER BOARD via P5.

## Software memory card

The SOFTWARE MEMORY CARD contains the operating system and the Servo Screen 390 application software. Loading of the software into the INTERNAL MEMORY is initialized by the SS390-BIOS during start-up.

There are two different versions of the SOFTWARE MEMORY CARD:

- PC Card™ used on PC 1662.
- CompactFlash™-card used on PC 1835.  
Note – As patient related TRENDS and unit related EVENT LIST are stored on the CompactFlash-card, it is not recommended to move a CompactFlash-card between different units.

The software on the memory card is specifically designed for Servo Screen 390, and cannot be used on a standard PC.

The software memory card is easy to replace in case of future software upgrades. See chapter 4, "Service procedures".

## Battery

The lithium BATTERY (3.6 V) is used to back up the computer setup stored in the CMOS-RAM and, for PC 1662, also to back up the SRAM. If the battery is disconnected, factory default settings will be used next time the Servo Screen 390 is started.

The battery must be replaced every three years. The message "Replace Servo Screen 390 battery" in the message window indicates when the battery should be replaced. A new three-year period will start when the battery replacement has been confirmed with the BATTERY CHANGE icon in the SERVICE MENU.

Replacing the battery and Battery change confirmation is described in chapter 4, "Service procedures".

### Pulse generator

The PULSE GENERATOR with its CONTROL KNOB (physically mounted as a part of the display section) is the only necessary device available to a clinical user for operating the application software. The pulse generator itself does not include any functions other than interaction with the software.

## 2

### Connection ports

All CONNECTION PORTS except the power port are mounted on the COMPUTER BOARD. More information about the connection ports can be found in chapter 7, "Diagrams".

### Display

A monochrome electro-illuminating DISPLAY is used in this version of Servo Screen 390.

Display connection cables connect the display to the block SIGNAL ADAPTION via connector J1 and to the block BRIGHTNESS CONTROL via connectors J2 and J3.

The unit is prepared for possible future versions with other display types.

## Disassembly and assembly

General .....	18
Handling PC boards .....	18
Separating the display section from the computer section .....	19
Assembling the display section with the computer section .....	19
Disassembling the display section .....	20
Pulse generator .....	20
Display .....	20
Front panel filter .....	21
Assembling the display section .....	21
Disassembling the computer section .....	22
Computer board PC 1662/PC 1835 and Adapter board PC 1663 .....	22
Fan .....	23
Assembling the computer section .....	23

## General

This chapter describes disassembly and assembly of some of the main parts of the Servo Screen 390. The drawings in the Spare parts list are also very useful as a guide when disassembling and assembling the Servo Screen 390.

Before disassembling or assembling the Servo Screen 390, make sure that all connection cables are disconnected from the connection ports of Servo Screen 390.

After any service intervention in the Servo Screen 390, perform a Functional check according to instructions in the Operating manual.

## Handling PC boards

The PC boards contain components that are highly sensitive to static electricity.

Those who come into contact with circuit boards containing sensitive components must take certain precautions to avoid damaging the components (ESD protection).

When working with ESD sensitive components, always use a grounded wrist band and grounded work surface. Adequate service tools must also be used.

PC boards (spare parts) must always be kept in protective packaging for sensitive electronic devices.

PC boards must not be inserted or removed while power is applied to the PC boards.

Remove and insert the PC boards very carefully to avoid damage to the connectors.

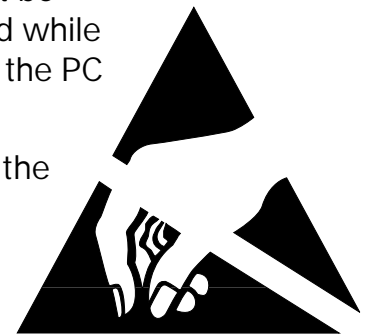

## Separating the display section from the computer section

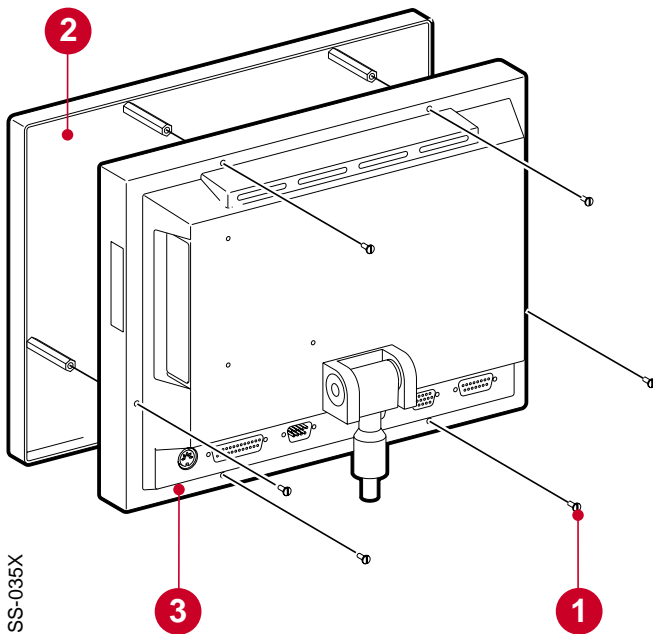

- Remove the six screws (1).
- Carefully separate the display section (2) from the computer section (3) as much as is needed to make the pulse generator connector N12 on PC 1662 and connectors N1, N2 and N3 at the rear of the display accessible.
- Disconnect the connectors mentioned above.
- The display section is now separated from the computer section.

3

## Assembling the display section with the computer section

The procedure for assembling the display section with the computer section is the reverse of the separation procedure described above.

Make sure that the rubber sealing strips are mounted on the display section to obtain a good seal between the sections.

## Disassembling the display section

### Pulse generator

- Separate the display section from the computer section as previously described.
- Pull off the control knob (1) from the pulse generator shaft.
- Remove the nut (2) and the washer (3) and lift off the pulse generator (4).

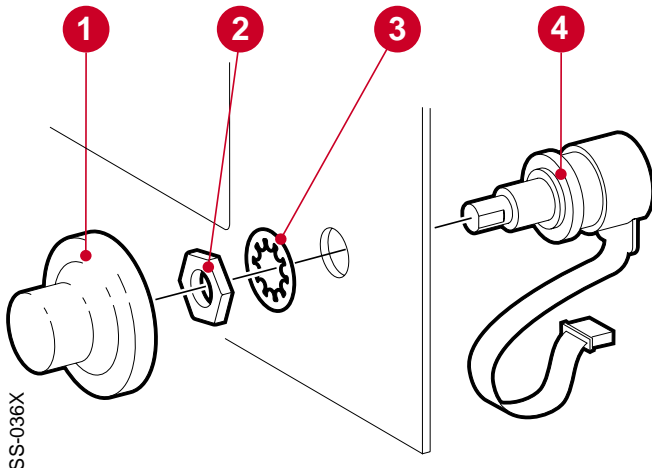

3

### Display

- Separate the display section from the computer section as previously described.
- Remove the four nuts (1) and the eight washers (2 and 3).
- Lift off the complete display (4).
- Note the four spacers (5). Make sure that they are mounted when assembling the display.

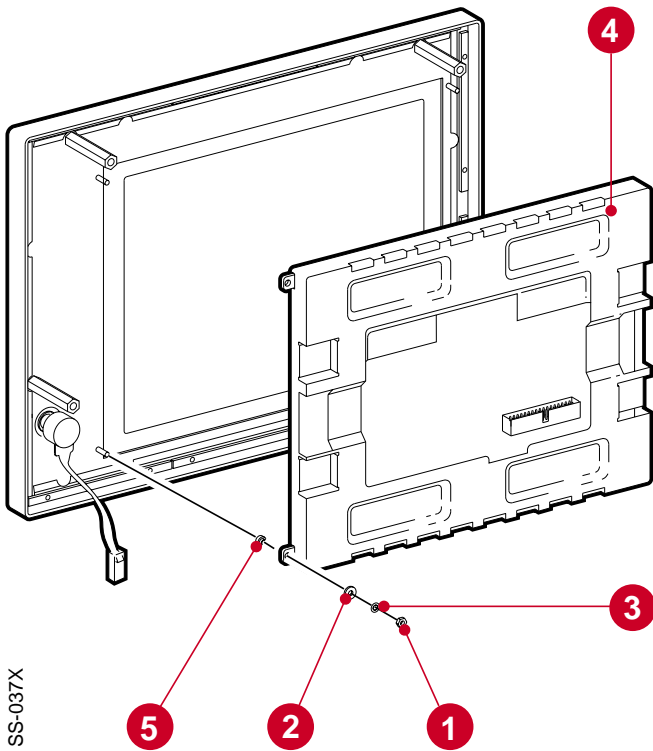

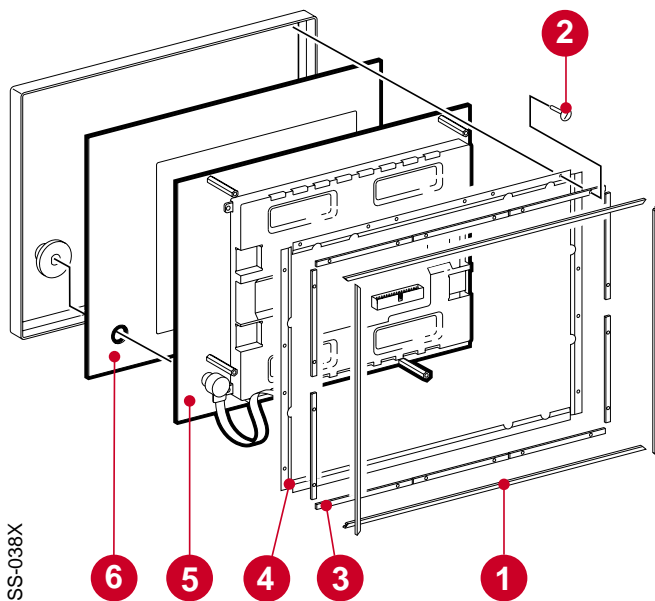

### Front panel filter

- Separate the display section from the computer section as previously described.
- Pull off the control knob from the pulse generator shaft.
- Remove the rubber sealing strips (1).
- Remove the screws (2) holding the bars (3).
- Lift off the bars (3) and the copper plates (4).
- Lift off the support plate (5) including the display.
- Lift off the front panel filter (6).

3

### Assembling the display section

The procedure for assembling the display section is the reverse of the disassembly procedure described above.

## Disassembling the computer section

### Computer board PC 1662/PC 1835 and Adapter board PC 1663

The PC boards are connected to each other in such a way that its *not* possible to remove just one of them from the computer section. Both PC boards must be removed at the same time.

- Remove the software memory card.
- Separate the display section from the computer section as previously described.
- Remove the eight spacer screws (1) holding the connection ports to the rear cover. Do not remove the screws holding the power port (PWR).
- Disconnect the internal power cable connector N18 from P18 on PC 1663.
- Disconnect the battery connector N0 from P13/P14 on PC 1662/PC 1835.  
Note – Computer setup information stored in the CMOS-RAM, and for PC 1662 also information stored in the SRAM, will be erased when the battery is disconnected. Factory default settings will be used next time the Servo Screen 390 is turned on.
- Remove the two nuts (2) and washers (3).
- Remove the two screws (4) holding PC 1662/PC 1835.
- Carefully lift the PC boards from the computer section as much as needed to make the ON/OFF switch connector N15 at P15 and the fan connector N16 at P16 on PC 1663 accessible.
- Disconnect the connectors mentioned above.
- Lift off the PC boards.
- Carefully separate the computer board from the adapter board.

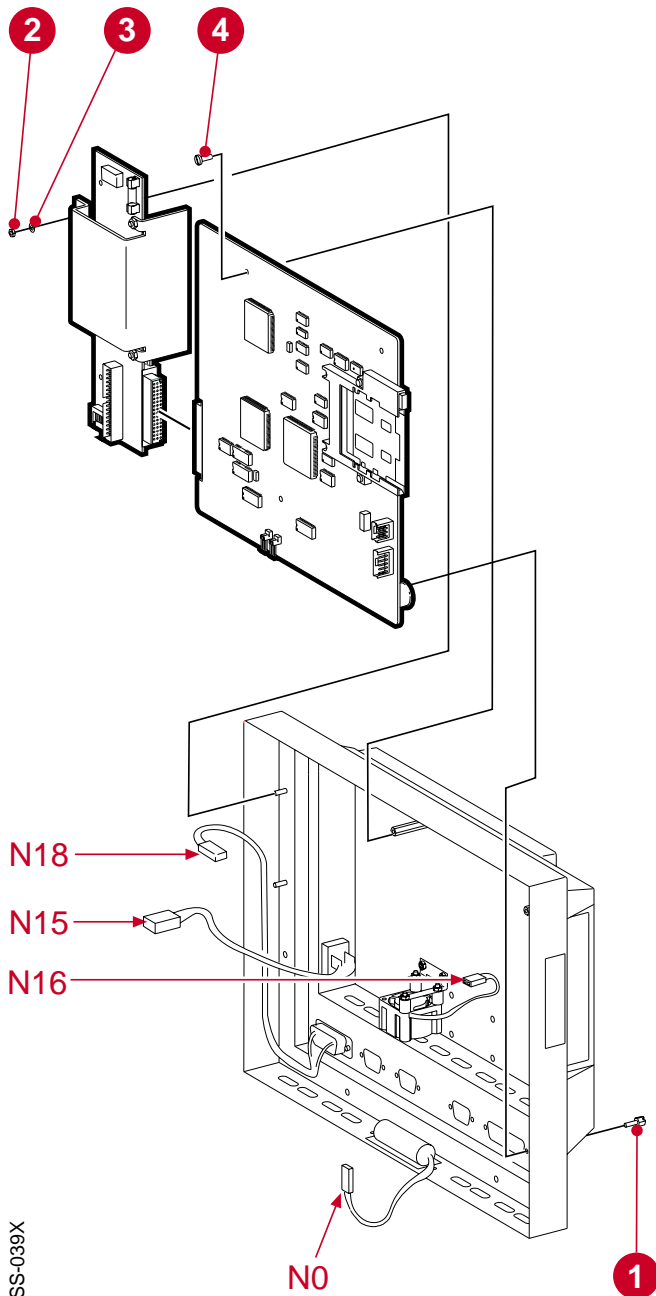

SS-039X

The two different versions of the computer board are interchangeable. Refer to further information in the Spare Parts List when replacing a PC 1662 with a PC 1835.

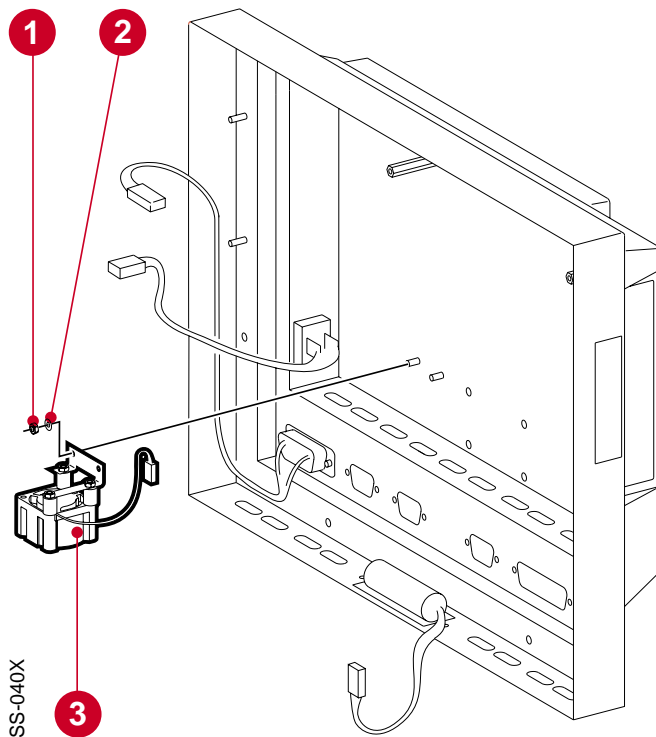

### Fan

- Remove the PC boards as previously described.
- Remove the two nuts (1) and washers (2) holding the fan bracket and lift off the fan (3).

## Assembling the computer section

The procedure for assembling the computer section is the reverse of the disassembly procedure described above.

Normally the screen area will light up immediately when the power switch is set to On. If the screen area is not lit up until the Startup display appears and the startup beep sounds, this may be due to an undefined brightness value stored on the Adapter board. This may be the case after exchange of Adapter board PC 1663.

Adjust the brightness setting as follows:

- Set the power switch to On and wait until the Main menu icons are visible.
- Select SYSTEM DATA and CHANGE SET-UP.
- Change the Brightness level (at least one step).
- Select CHANGE EXIT and SAVE SET-UP. Save the new setting.
- Set the power switch to Off and wait a few seconds.
- Set the power switch to On and check that the screen area is lit up immediately.
- If required, repeat the steps above to set the Brightness level to the previous value.



## Service procedures

General .....	26
Using the Service Menu .....	27
Service access code .....	27
Service information display .....	28
Event list .....	28
Battery change-confirmation .....	29
Using a keyboard .....	30
Replacing the software memory card .....	31
Replacing the SS390-PROM on PC 1662 .....	32
Upgrading the SS390-FLASH on PC 1835 .....	32
Replacing the internal memory .....	33
Replacing the battery .....	34
Replacing the fuse .....	35
Adjusting the support arm .....	36
Joint .....	36
Rail clamp .....	36

## General

This chapter describes, step-by-step, some service procedures that may be necessary to perform on the Servo Screen 390. Some of these service procedures require disassembling the Servo Screen 390. If so, please see chapter 3, "Disassembly and assembly" for instructions.

Before disassembling or assembling the Servo Screen 390, make sure that all connection cables are disconnected from the connection ports of Servo Screen 390.

After any service intervention in the Servo Screen 390, perform a Functional check according to the instructions in the Operating manual.

## Using the Service Menu

The Service Menu serves three purposes:

- It gives access to the Service information display.
- It gives access to the EVENT LIST.
- It gives access to the BATTERY CHANGE icon. This icon is selected to confirm that the Servo Screen 390 battery has been replaced.

### Service Access Code

The Service Access Code is intended only as a "separator" between clinical use and technical use of the Servo Screen 390. It is not a secret or personal code and it cannot be changed.

- Select the SERVICE MENU as described in the Operating Manual.
- Enter the Service Access Code on the numerical entry keypad displayed on the Servo Screen 390. The Service Access Code is:

300

- Turn the control knob until the ACCEPT key is marked.
- Press the control knob. The Service information display is now shown. The Service menu icons are also displayed.



### Service information display

The Service information display shows some technical data from the connected ventilator and from the Servo Screen 390.

If the Servo Screen 390 is connected to a Servo Ventilator 300/300A, PROM versions in the SV 300/300A are shown on this display.

The Service information display will also show the SS390-BIOS version and the application software version of the Servo Screen 390.

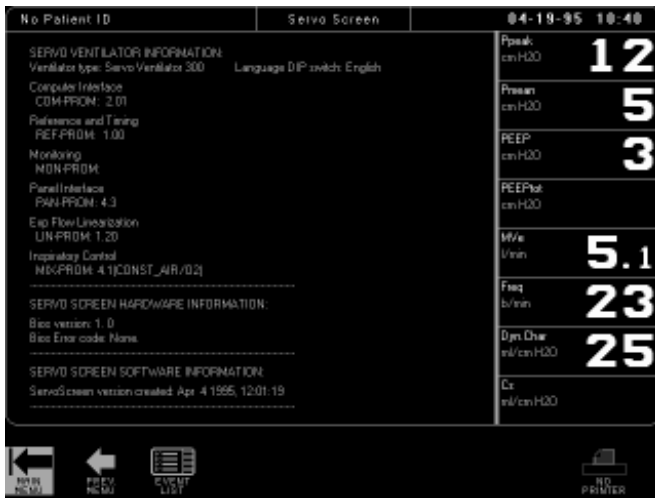

### Event list

The event list in Servo Screen 390 logs technical errors, abnormal events and displayed messages.

- Enter the Service Menu, using the Service Access Code as previously described.
- Turn the control knob until the EVENT LIST icon is marked.



- Press the control knob. The event list is now displayed.
- Use the NEXT PAGE and PREV. PAGE icons to select a page in the event list.

The message string contains up to six information units:

- Date
- Time
- Event type
- File line
- Error message
- Error code (if available)



### Battery change-confirmation

The backup battery in the Servo Screen 390 must be replaced when the information "Replace Servo Screen 390 battery" is displayed in the Message window (every three years). Replacement is described in the section "Replacing the battery" in this chapter.

Battery replacement must be confirmed to remove the "Replace Servo Screen 390 battery" message. This confirmation also sets the time used for controlling the appearance of the message. The message will appear after startup:

- three years after the latest Battery change-confirmation or
- if the battery has been disconnected.

Note – It is not recommended to re-connect a used battery and perform the necessary Battery change-confirmation. The fixed time interval until next appearance of the "Replace Servo Screen 390 battery" is selected for a fully charged battery.

Confirm battery change as follows:

- Connect the Servo Screen 390 to a ventilator.
- Start the ventilator and the Servo Screen 390.
- Check that the Time and Date settings displayed in Servo Screen 390 are correct. If necessary, adjust according to the instructions in the Operating Manual.
- Enter the Service Menu, using the Service Access Code as previously described.
- Turn the control knob until the BATTERY CHANGE icon is marked.
- Press the control knob. The battery replacement is now confirmed. The message in the Message window will disappear immediately, but the BATTERY CHANGE icon will not disappear until another menu is selected.



## Using a keyboard

A standard AT keyboard can be connected to the Servo Screen 390.

When the keyboard is connected, it is ready for use. No setting is needed. The keyboard can be used as a substitute for the control knob/pulse generator, but it can also be used in combination with the control knob/pulse generator.

The following keys are used to simulate the control knob:

- Left-arrow key = Turning the control knob counter-clockwise.
- Right-arrow key = Turning the control knob clockwise.
- Enter key = Pressing the control knob.

The keyboard can be used when troubleshooting a possible malfunction in the control knob function, for example. If there is a malfunction when using the control knob/pulse generator and this malfunction does not appear when using a connected keyboard, the error may be in the pulse generator or in the pulse generator interface.

The keyboard can also be used in combination with the "on-screen keyboard" when entering or changing a patient ID. Only upper case letters will be displayed in the Patient ID field.

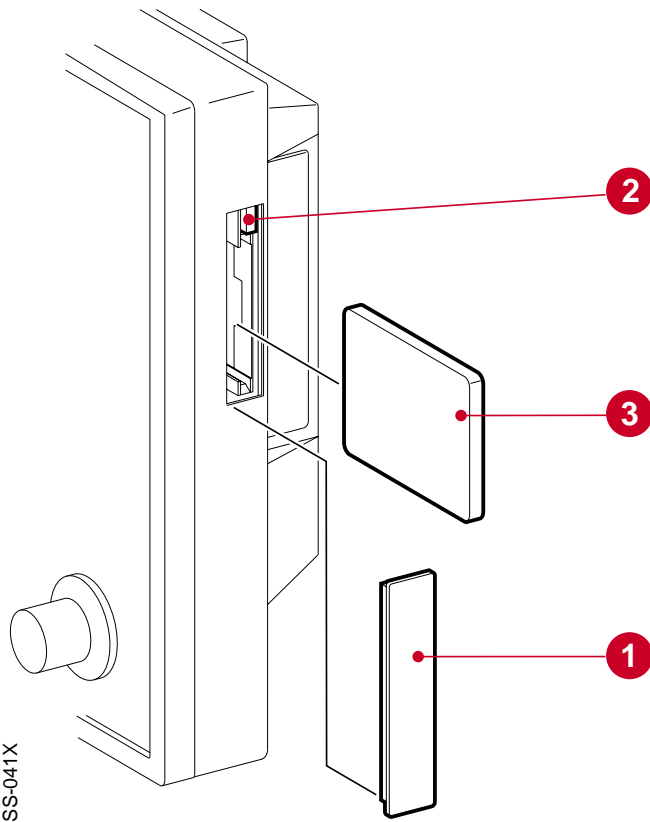

SS-041X

## Replacing the software memory card

- Make sure that the Servo Screen 390 is turned off.
- Remove the protective cover (1).
- Push the button (2) to release the software memory card from the memory card slot.
- Pull out the software memory card (3).
- Put the desired software memory card into the memory card slot. A mechanical key on the card and in the slot prevents it from being fully inserted in a wrong position.
- Push the software memory card into the slot. Mount the protective cover (1).

The software memory card is now replaced. Perform a Functional check according to the instructions in the Operating Manual.

There are two different versions of the software memory card:

- PC Card™ used on Servo Screen 390 equipped with Computer board PC 1662.
- CompactFlash™ used on Servo Screen 390 equipped with Computer board PC 1835. Note – As patient related TRENDS and unit related EVENT LIST are stored on the CompactFlash-card, it is not recommended to move a CompactFlash-card between different units.

The procedure for replacing the software memory card is the same for the two different versions

## Replacing the SS390-PROM on PC 1662

Before performing this service action, read the sections "General" and "Handling PC boards" in chapter 3, "Disassembly and assembly".

- Remove the PC boards as described in chapter 3, "Disassembly and assembly".
- Use an extraction tool to remove the old SS390-PROM (1) mounted at the rear of PC 1662.
- Mount the new SS390-PROM into the socket. Make sure that it is correctly mounted and that no leg has been bent or broken.
- Assemble the Servo Screen 390 as described in chapter 3, "Disassembly and assembly".

The SS390-PROM is now replaced. Perform a Functional check according to the instructions in the Operating Manual.

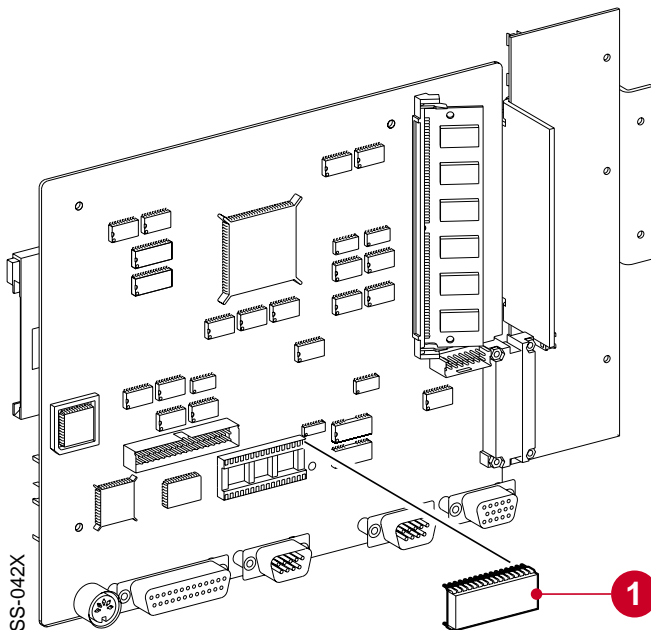

4

## Upgrading the SS390-FLASH on PC 1835

A Service CompactFlash™-card will be used to upgrade the SS390-FLASH on PC 1835. Upgrade instructions will be delivered with this Service card.

## Replacing the internal memory

Before performing this service action, read the sections "General" and "Handling PC boards" in chapter 3, "Disassembly and assembly".

Note – This procedure and illustration shows SIMM chip on PC 1662. The board PC 1835 is equipped with a different type of SIMM chip but the replacement procedure is still the same. PC 1835 is also prepared for and can, in the future, be equipped with SIMM chips mounted on the rear side of the PC board. If so, the PC board does not have to be removed when replacing the internal memory.

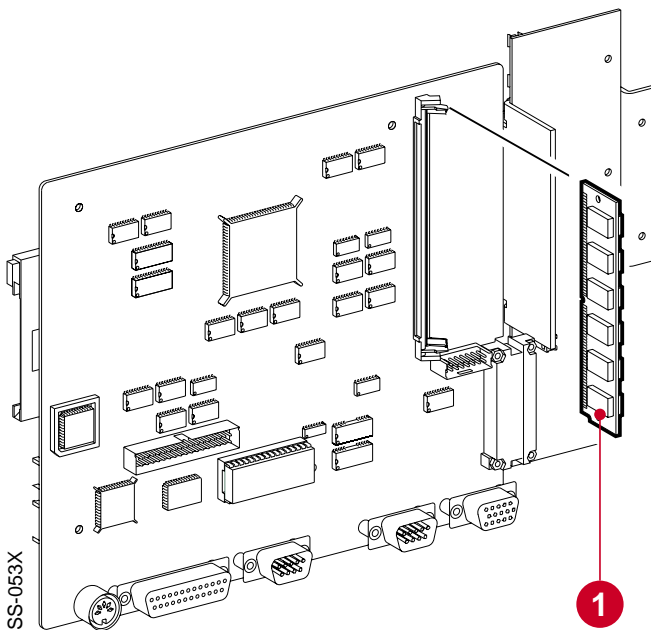

- Remove the PC boards as described in chapter 3, "Disassembly and assembly".
- Remove the old SIMM chip (1) mounted on PC 1662/PC 1835.
- Mount the new SIMM chip into the socket.
- Assemble the Servo Screen 390 as described in chapter 3, "Disassembly and assembly".

The internal memory is now replaced. Perform a Functional check according to the instructions in the Operating Manual.

## Replacing the battery

When the information "Replace Servo Screen 390 battery" is displayed in the Message window, the battery must be replaced.

- Make sure that the Servo Screen 390 is turned off.
- Loosen the two screws (1).
- Carefully lift off the battery cover including battery (2), but *do not* remove the cable connector (3) from PC 1662/PC 1835. Note – Computer setup information stored in the CMOS-RAM, and for PC 1662 also information stored in the SRAM, will be erased if the connector is removed. In that case, factory default settings will be used next time the Servo Screen 390 is turned on.
- There are two equal battery connectors connected in parallel (P13 and P14) on PC 1662/PC 1835. Connect the new battery (4) to the unused connector. The battery backup functions are now secured by the new battery.
- Cut the cable tie holding the old battery to the battery cover. Mount the battery cover to the new battery using a new cable tie.
- Disconnect and remove the old battery.
- Mount the battery cover including battery on Servo Screen 390.

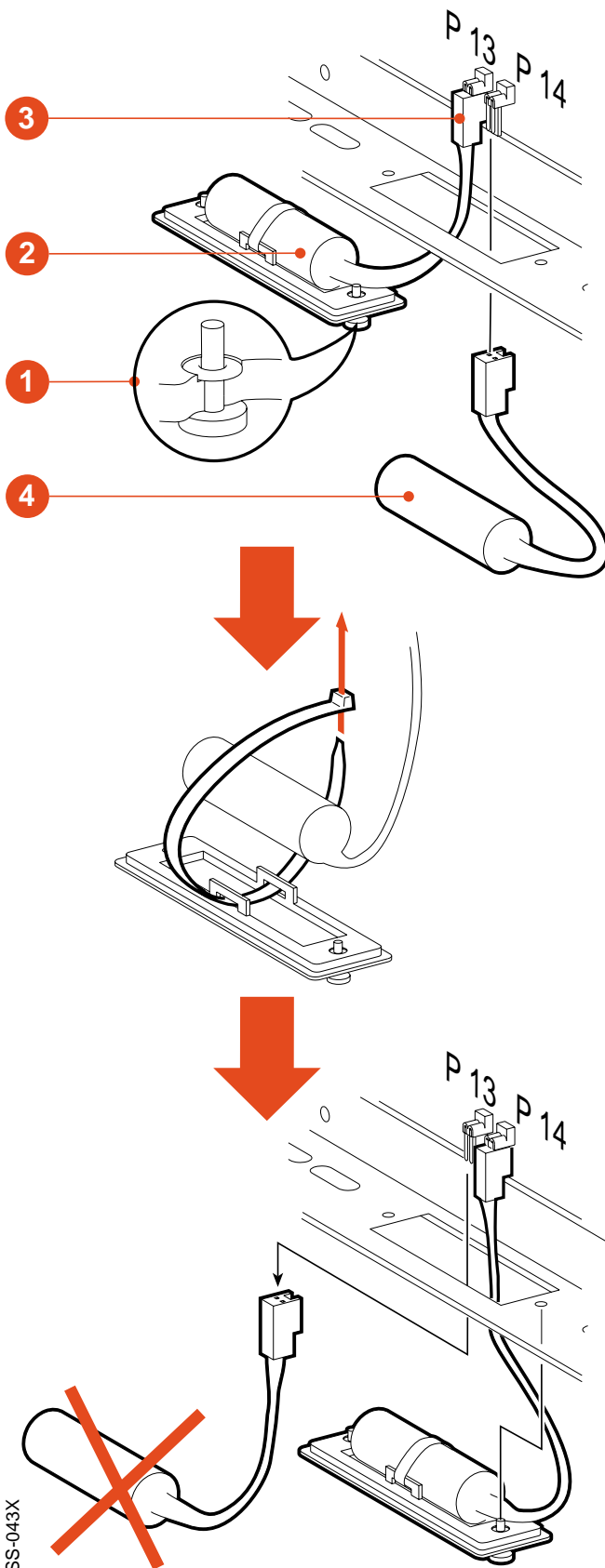

SS-043X

The old battery must be disposed of according to local or national regulations.

Battery replacement must be confirmed in the SERVICE MENU within the application software. This is described in the section "Using the Service Menu" in this chapter.

The battery is now replaced. Perform a Functional check according to the instructions in the Operating Manual.

## Replacing the fuse

Before performing this service action, read the sections "General" and "Handling PC boards" in chapter 3, "Disassembly and assembly".

- Separate the display section from the computer section as described in chapter 3, "Disassembly and assembly".
- Remove the old fuse (1).
- Insert a new fuse, 3.15 A fast.
- Assemble the Servo Screen 390 as described in chapter 3, "Disassembly and assembly".

The fuse is now replaced. Perform a Functional check according to the instructions in the Operating Manual.

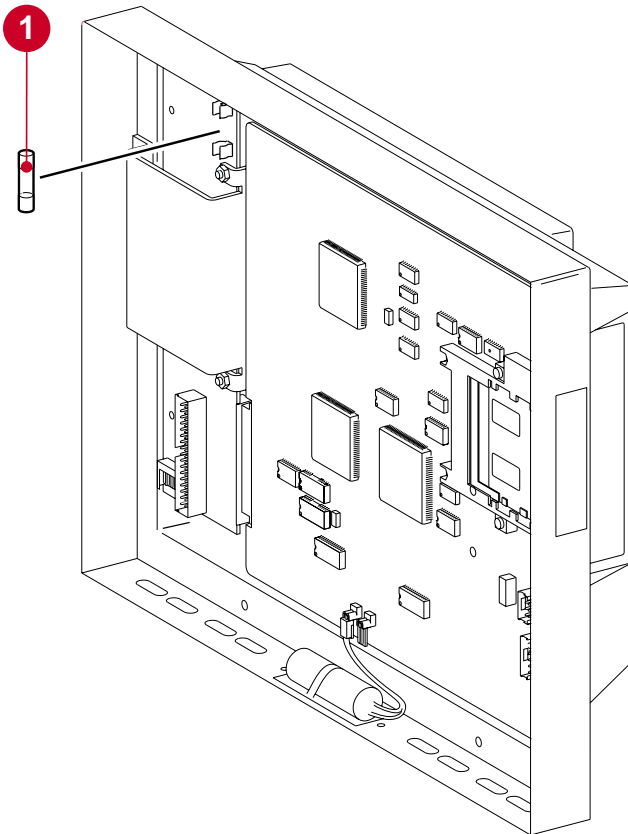

SS-044X

## Adjusting the support arm

The pre-tension in the joint as well as in the rail clamp can be adjusted if necessary:

### Joint

- Loosen the screw (1).
- Tighten or loosen the screw (2).
- Secure the new adjustment by tightening the screw (1).

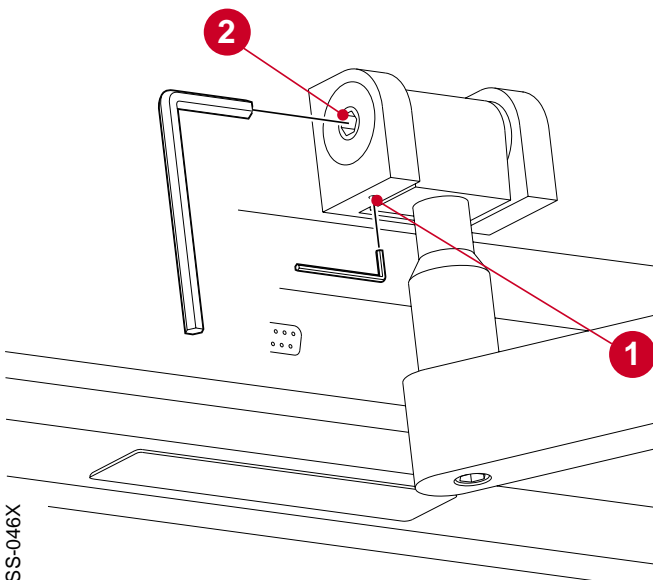

SS-046X

4

### Rail clamp

- Loosen the screw (1).
- Turn the lever (2):
  - Clockwise to increase the tension in the clamp.
  - Counter-clockwise to reduce the tension in the clamp.

Note – The lever must be given either half turns or full turns.

- Secure the new adjustment by tightening the screw (1).

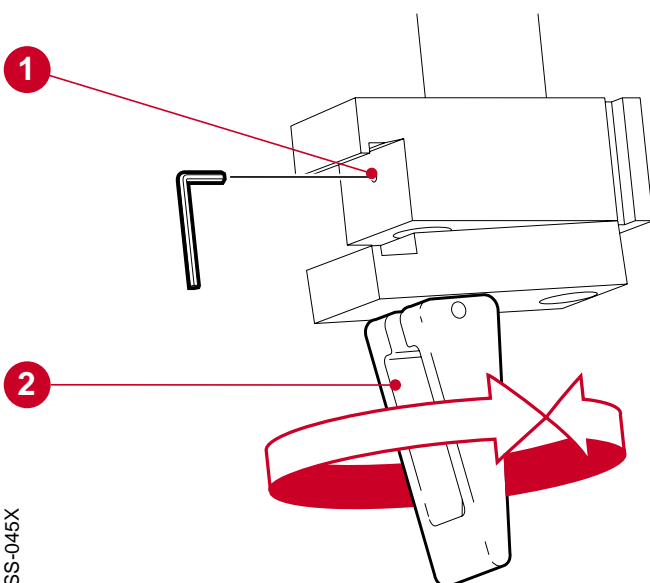

SS-045X

# Troubleshooting

Before starting troubleshooting, try to eliminate all possibilities of operational errors. If the malfunction remains, use the troubleshooting guide below. Perform actions step by step and check that the malfunction is eliminated.

When the fault is corrected, carry out a Functional check as described in the Operating Manual, chapter 4, "Startup and shutdown".

## Malfunction

## Action

Servo Screen 390 will not start. The display is not illuminated and there is no start-up beep.

- Check/replace the external power cable/ connectors.
- Check that the power supply source (ventilator or external power supply) works properly.
- Check the fuse F1 on PC 1663.
- Check/replace the internal power cable/ connectors.
- Check/replace the Servo Screen 390 power switch and its cable/connector.
- If none of the above, replace PC 1663.
- If none of the above, replace PC 1662/ PC 1835.

5

The display is illuminated at power on and one or more start-up beeps can be heard within 20 s after power on. Thereafter the display may flash or will be completely illuminated. A connected CRT display is not illuminated and shows no text.

- Hardware failure. Replace PC 1662/ PC 1835.

The display is not illuminated, but a connected CRT display is illuminated and shows the start-up sequence.

- Check/replace the display power and signal cables.
- If not the above, replace the display.
- If none of the above, replace PC 1663.
- If none of the above, replace PC 1662/ PC 1835.

## Malfunction

## Action

The display is illuminated during start-up, but after the start-up beep it goes black or shows a deformed image. A connected CRT display shows a normal start-up sequence and image.

- Check/replace the signal cable between PC 1663 and the display.
- If not the above, replace the display.

The start-up logo does not disappear and:

- the message "LOADING SOFTWARE" does not disappear within 30 s *or*
- the message "SOFTWARE MISSING" appears.

- Replace the software memory card.
- If not the above, replace PC 1662/PC 1835.

The control knob does not work properly.

- Operate the Servo Screen 390 with a connected keyboard:
  - If it works with the connected keyboard:
    1. Replace the control knob.
    2. If not the above, replace PC 1662/PC 1835.
  - If it does not work with the connected keyboard:
    1. Replace PC 1662/PC 1835.

The brightness of the display can not be adjusted.

- Check the power cable from PC 1663 to the internal display.
- If not the above, replace PC 1663.
- If none of the above, replace the display.

It is not possible to establish communication between Servo Screen 390 and an SV 300/300A or an SV 900C/E.

- Check/replace the communication cable.
- Try to communicate with another ventilator (on SV 900C/E, first make sure that the SCM 990 is properly configured).
- If none of the above, replace PC 1662/PC 1835.

## Malfunction

## Action

It is not possible to print out on the connected printer.

- Check/replace the printer cable.
- Make sure that the printer itself is properly configured.
- Make sure that the connected printer is selected in the printer list in Servo Screen 390.
- Try to connect another printer.
- If none of the above, replace PC 1662/PC 1835.

Information message "Replace Servo Screen 390 battery" remains in the Message window although the battery has been replaced.

- Confirm the battery replacement using the BATTERY CHANGE icon in the Service Menu.
- If not the above, replace PC 1662/PC 1835.

It is not possible to set Time or Date in Servo Screen when connected to a SV 300/300A.

- Make sure that the communication cable between Servo Screen and SV 300/300A is connected to N82 on SV 300/300A.

The Servo Screen 390 starts up, but does not display any information (e.g. curves or numerical values) from the SV 300/300A.

- Reset the memory in SV 300/300A-PC 1587. See SV 300/300A – Service Manual (printed 1996 or later).

# Index



	Introduction	Description of functions	Disassembly and assembly	Service procedures		Introduction	Description of functions	Disassembly and assembly	Service procedures
<b>A</b>									
Adapter board PC 1663	9	13	22			9	14	23	
AC Power Adapter 124		12					13		
<b>B</b>									
Battery		15							
Battery change-icon				29					
Battery replacement				34					
Board identity		13							
Brightness control		13							
Bus interface		14							
<b>C</b>									
COM port	7								
CompactFlash Card		15		31					
Computer board PC 1662	9	14	22						
Computer board PC 1835	9	14	22						
Computer section	9		22						
Connection ports	7	16							
Control knob	7	15							
CTR port	7								
<b>D</b>									
Display	7	16	20						
Display connection cables		14							
Display section	8		20						
<b>E</b>									
ESD protection			18						
Event list		15		28					
<b>F</b>									
Fan									
Fan control									
Firmware						9			
Front panel filter						8		21	
Fuse							13		35
<b>H</b>									
Handling PC boards								18	
<b>I</b>									
Internal memory							14		33
Internal power cable							13		
<b>K</b>									
KBD port									
Keyboard						7			30
<b>M</b>									
Microprocessor								14	
<b>O</b>									
On/off switch						7	14		
<b>P</b>									
PC Card							15		31
Power supply							12		
PRINTER port						7			
Protective cover						7			31
Pulse generator						7	16	20	
Pulse generator interface							14		
PWR port						7			

	Introduction	Description of functions	Disassembly and assembly	Service procedures
<b>S</b>				
Service access code				27
Service information display				28
Service menu				27
Signal adaption		13		
Software	9			
Software memory card	7	15		31
Software mem. card interface		15		
SRAM		15		
SS390-BIOS	9	15		
SS390-FLASH		15		32
SS390-PROM		15		32
Support arm	8			
Support arm joint				36
Support arm rail clamp				36
<b>V</b>				
VENT port	7			
Video memory		14		
VGA controller		14		
Voltage distribution	9	13		
Voltage & Function monitoring		14		



# Diagrams

SS-048X

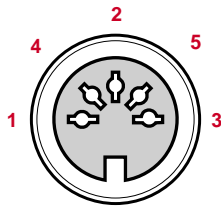

**KBD – N6**

Keyboard port for connection of a keyboard.  
DIN 41524, female, 5 pole.

1	KEY_CLK	4	GND
2	KEY_DATA	5	+5 V
3	-	A*	CHASSIS_GND

SS-049X

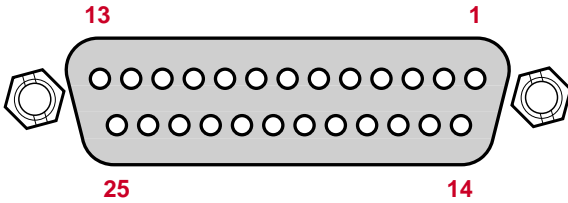

**PRINTER – N7**

Printer port for connection of a printer.  
D-Sub, female, 25 pole.

1	LPT_STROBE.L	14	LPT_AUTOFD_L
2	LPT_PD_0	15	LPT_ERROR.L
3	LPT_PD_1	16	LPT_INIT.L
4	LPT_PD_2	17	LPT_SLCTIN.L
5	LPT_PD_3	18	GND
6	LPT_PD_4	19	GND
7	LPT_PD_5	20	GND
8	LPT_PD_6	21	GND
9	LPT_PD_7	22	GND
10	LPT_ACK.L	23	GND
11	LPT_BUSY	24	GND
12	LPT_PE	25	GND
13	LPT_SLCT	A*	CHASSIS_GND

SS-050X

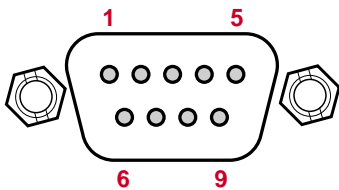

**COM – P8**

Serial communication port for communication with other equipment.  
D-Sub, male, 9 pole. (For future applications. Dependent on the software version.)

1	DCD_1A	6	DSR_1A
2	RXD_1A	7	RTS_1A
3	TXD_1A	8	CTS_1A
4	DTR_1A	9	RL_1A
5	GND	A*	CHASSIS_GND

SS-051X

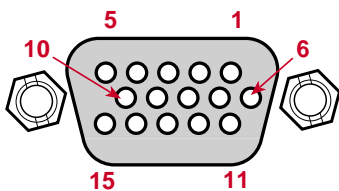

**CRT – N10**

CRT port for connection of an external monitor. HD D-Sub, female, 15 pole.

1	RED_CRT	9	-
2	GREEN_CRT	10	GND
3	BLUE_CRT	11	-
4	-	12	-
5	GND	13	HSYNC_CRT
6	0 VA	14	VSYNC_CRT
7	0 VA	15	-
8	0 VA	A*	CHASSIS_GND

\* A = Connected to the metal housing of the connector.

SS-050X

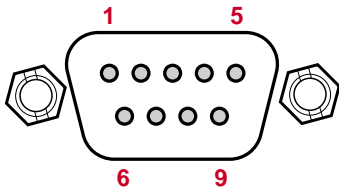

**Communication cable between SS 390 and SV 300/300A**

9-pin connector      26-pin connector

**VENT – P9**

pin #		pin #
5	----- BN	2
8	----- RD	3
2	----- WH	4
3	----- BU	5
7	----- GN	6
6	----- YE	7

**N82**

**Communication cable between SS 390 – SCM 990**

9-pin connector      26-pin connector

**VENT – P9**

pin #		pin #
1	----- GN	4
2	----- YE	2
3	----- GY	3
4	----- PK	5,6
5	----- BU	7
6,8	----- WH	20
7	----- RD	8

**RS232C – N1**

SS-052X

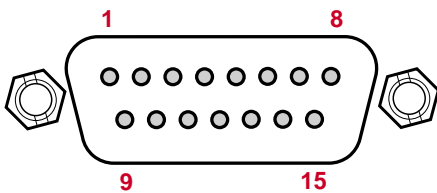

**24 V power cable between SS 390 and SV 300/300A or SS 390 and AC Power Adapter 124**

15-pin connector      15-pin connector

**PWR – P21**

pin #		pin #
7	----- YE	7
8	----- GN	8
1	----- BN	1
2	----- WH	2

**N78 on SV 300/300A**

**VENT – P9**

Serial communication port for communication with the Servo Ventilator. D-Sub, male, 9 pole.

1	DCD_2A	6	DSR_2A
2	RXD_2A	7	RTS_2A
3	TXD_2A	8	CTS_2A
4	DTR_2A	9	RI_2A
5	GND	A*	CHASSIS_GND

**PWR – P21**

Power port for connection to a 24V power source. D-Sub, male, 15 pole.

1	+24 V	9	-
2	+24 V	10	-
3	-	11	-
4	-	12	-
5	-	13	-
6	-	14	-
7	GND	15	-
8	GND	A*	CHASSIS_GND

\* A = Connected to the metal housing of the connector.



# 7. Diagrams

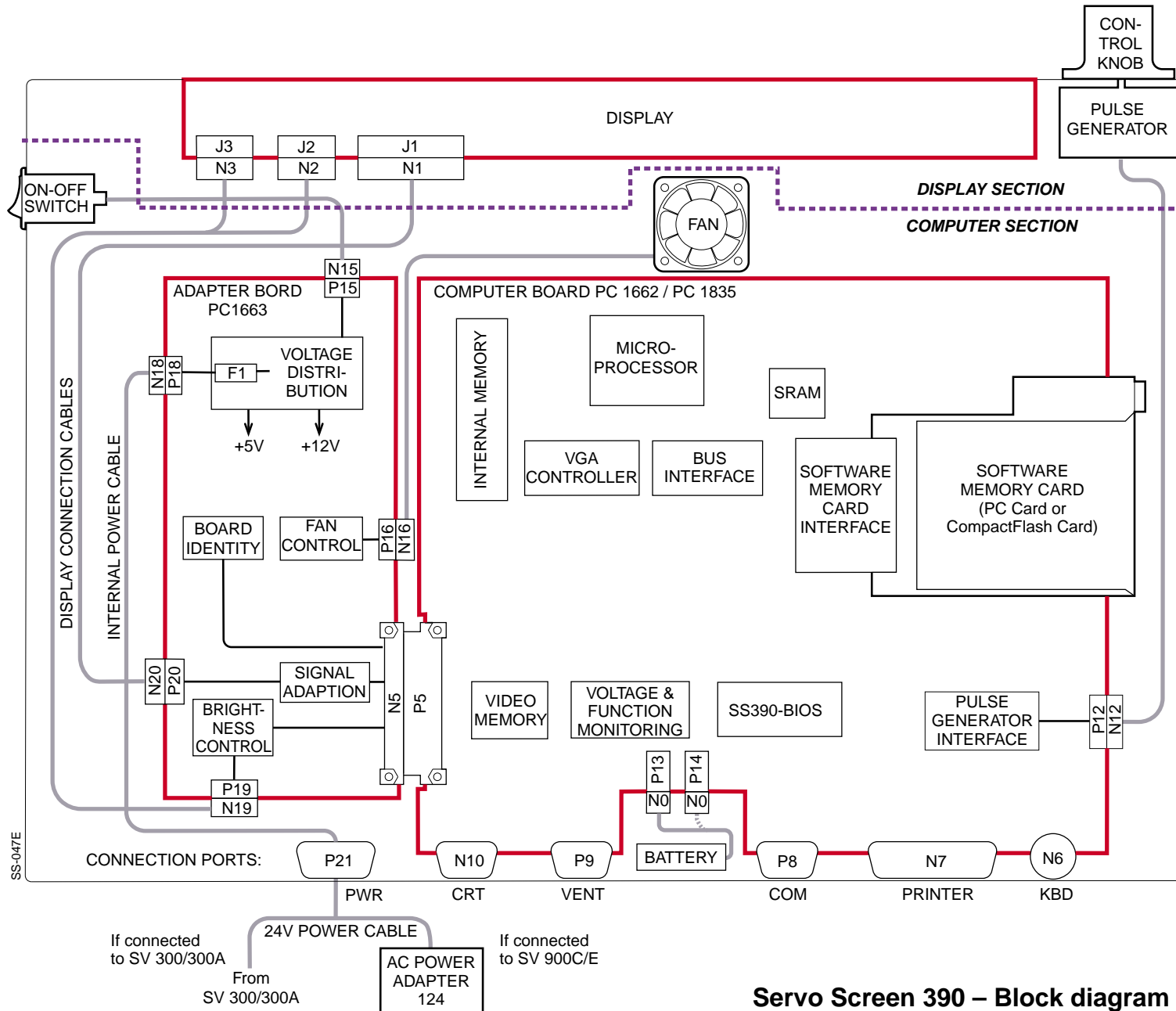

**Servo Screen 390 – Block diagram**

Servo Screen 390 – Service Manual  
Order No.: 63 14 251 E394E

E382 E394E 061 01 02 02

---

© Siemens-Elema AB, Electromedical Systems Division, 1995-2000. All rights reserved. No part of this publication may be reproduced, stored in a retrieval system, or transmitted in any form or by any means, electronic, mechanical, photocopying, recording, or otherwise, without the prior permission of the copyright owner in writing. Subject to alterations without prior notice.  
Issued by Siemens-Elema AB, Electromedical Systems Division, SE-171 95 Solna, Sweden.

Printed in Sweden  
Price group: 5  
**0600** 0.5  
2nd English edition,  
June 2000